

Instruction Manual

ZEISS Axioscope 5, Axioscope 5/7 MAT

Upright Microscope for Routine and Entry-Level Research



ZEISS Axioscope 5, Axioscope 5/7 MAT

Original Manual

Document Title: Instruction Manual ZEISS Axioscope 5, Axioscope 5/7 MAT

Order Number: 430035-7011-101

Revision: 2

Language: en-US

Effective from: 08/2025



© 2025 Without the prior written consent of ZEISS, this document or any part of it must neither be translated nor reproduced or transmitted in any form or by any means - including electronic or mechanic methods, by photocopying, recording or by any information or filing system. The right to make backup-copies for archiving purposes shall remain unaffected thereby. Any violations may be prosecuted as copyright infringements.

The use of general descriptive names, registered names, trademarks, etc. in this document does not imply that such names are exempt from the relevant intellectual property laws and regulations and therefore free for general use. This shall also apply if this is not specifically referred to. Software programs shall entirely remain the property of ZEISS. No program or subsequent upgrade thereof may be disclosed to any third party, copied or reproduced in any other form without the prior written consent of ZEISS, even if these copies or reproductions are destined for internal use at the customer's only, the only exception being one single back-up copy for archiving purposes.

Table of Contents

1	Contact and Addresses	8
2	About this Instruction Manual	9
2.1	Text Conventions and Link Types	9
2.2	Explanation of Warning Messages and Additional Information	10
2.3	Explanation of Symbols	11
2.4	Further Applicable Documents	12
3	Safety	13
3.1	Intended Purpose	13
3.2	General Safety Information	14
3.2.1	Requirements for Operators	14
3.2.2	Safe Operating Condition	14
3.2.3	Order and Use of Spare Parts	15
3.2.4	Lifetime	15
3.2.5	Optical Risk Grouping	15
3.2.6	EMC Information	16
3.3	Prevention of Hazards	17
3.3.1	Mechanical Hazards	17
3.3.2	Electrical Hazards	17
3.3.3	Hazards Generated with the Operating Environment	18
3.3.4	Ergonomic Hazards	18
3.3.5	Hazards Generated by Materials and Substances	18
3.3.6	Hazards Generated by Radiation	19
3.3.7	Thermal Hazards	19
3.4	Labels and Lights	20
3.4.1	Labels on the Axioscope	20
3.4.2	Labels on the motorized 80x60 Mechanical Stage	21
3.5	Safety Devices and Interlocks	21
4	Product and Functional Description	22
4.1	Axioscope 5 TL	23
4.1.1	Main Components of Axioscope 5 TL	23
4.1.2	Controls and Functional Elements of Axioscope 5 TL	24
4.2	Axioscope 5 TL/FL	25
4.2.1	Main Components of Axioscope 5 TL/FL	25
4.2.2	Controls and Functional Elements of Axioscope 5 TL/FL	26
4.3	Axioscope 5 TL/RL	27
4.3.1	Main Components of Axioscope 5 TL/RL and Axioscope 5 TL/RL Pol	27
4.3.2	Controls and Functional Elements of Axioscope 5 TL/RL and Axioscope 5 TL/RLPol	29
4.4	Axioscope 5 Vario	31
4.4.1	Main Components of Axioscope 5 Vario	31
4.4.2	Controls and Functional Elements of Axioscope 5 Vario Stand	32
4.5	Axioscope 7 TL	33
4.5.1	Main Components of Axioscope 7 TL	33
4.5.2	Controls and Functional Elements of Axioscope 7 TL	34

4.6	Axioscope 7 TL/FL	35
4.6.1	Main Components of Axioscope 7 TL/FL.....	35
4.6.2	Controls and Functional Elements of Axioscope 7 TL/FL.....	36
4.7	Axioscope 7 RL.....	37
4.7.1	Main Components of Axioscope 7 RL.....	37
4.7.2	Controls and Functional Elements of Axioscope 7 RL.....	38
4.8	Axioscope 7 TL/RL MAT.....	39
4.8.1	Main Components of Axioscope 7 TL/RL MAT.....	39
4.8.2	Controls and Functional Elements of Axioscope 7 TL/RL MAT Stand	40
4.9	Controls and Functional Elements on Components	41
4.9.1	Functions of Stand Keys and Display Elements.....	41
4.9.2	Binocular Tube	44
4.9.3	Eyepieces	48
4.9.4	Nosepiece with Objectives.....	49
4.9.5	Condenser Carrier	50
4.9.6	Condensers	50
4.9.7	Stages	52
4.9.8	Reflector Inserts	55
4.10	Light Manager Function	55
4.11	Microscopy and Contrast Methods.....	56
4.11.1	Transmitted Light Brightfield Contrast Using the KÖHLER Method.....	56
4.11.2	Transmitted Light Darkfield Contrast Using the KÖHLER Method.....	56
4.11.3	Transmitted Light Phase Contrast	56
4.11.4	Transmitted Light Differential Interference Contrast	56
4.11.5	Transmitted Light PlasDIC Microscopy.....	57
4.11.6	Transmitted Light Polarization Contrast.....	57
4.11.7	Reflected Light Brightfield Contrast Using the KÖHLER Method.....	60
4.11.8	Reflected Light Darkfield Contrast Using the KÖHLER Method.....	60
4.11.9	Reflected Light DIC and C-DIC Contrast.....	60
4.11.10	Reflected Light TIC Contrast.....	60
4.11.11	Reflected Light Polarization Contrast.....	63
4.11.12	Reflected Light Fluorescence Contrast.....	63
5	Installation	64
5.1	Unpacking and Setting up the Microscope	64
5.2	Assembling the Base Plate on the Stand	64
5.3	Assembling the Upper Part of the Stand on the Stand Column	65
5.4	Assembling the Binocular Tube.....	65
5.5	Assembling Components into the Binocular Tube.....	66
5.6	Assembling the Objectives.....	67
5.7	Assembling the Reflector Turret.....	68
5.8	Assembling the Stage Carrier.....	68
5.9	Assembling the Stage.....	69
5.9.1	Assembling the Stable Mechanical Stage and Specimen Holder	69
5.9.2	Assembling the Motorized Mechanical Stage on the Axioscope 7 Motorized Material Stand	69
5.10	Installing the Condenser Carrier.....	70
5.11	Assembling the Dry Darkfield Condenser	71
5.12	Assembling the Transmitted Light Source	72
5.13	Assembling the Reflected Light Source	72
5.14	Connecting the Microscope to the Mains	72

6	Operation	73
6.1	Prerequisites for Commissioning and Operation.....	73
6.2	Switching On the Microscope.....	73
6.3	Adjusting	74
6.3.1	Adjusting the Position of the Eyepieces	74
6.3.2	Focusing when Using Eyepiece Reticles	74
6.3.3	Adjusting the Upper Part of the Stand Vertically	75
6.3.4	Adjusting the Height Stop on the Condenser Carrier	75
6.3.5	Adjusting the Height Stop on the Focusing Drive.....	76
6.3.6	Using the Light Manager Function.....	76
6.3.7	Setting the ECO/Permanent Mode.....	78
6.4	Setting Up for Transmitted Light Contrast Techniques	78
6.4.1	Setting Up for Transmitted Light Brightfield Microscopy Using the KÖHLER Method	78
6.4.2	Setting Up for Transmitted Light Darkfield Microscopy Using the KÖHLER Method	82
6.4.3	Setting the Darkfield Contrast with a Dry Darkfield Condenser	84
6.4.4	Setting the Darkfield Contrast with an Immersion Oil Darkfield Condenser.....	84
6.4.5	Setting Up for Transmitted Light Phase Contrast Microscopy.....	85
6.4.6	Setting Up for Transmitted Light DIC Microscopy	86
6.4.7	Setting Up for Transmitted Light PlasDIC Microscopy	87
6.4.8	Setting Up for Transmitted Light Polarization	88
6.5	Setting Up for Reflected Light Techniques	93
6.5.1	Setting Up for Reflected Light Brightfield Microscopy Using the KÖHLER Method.....	93
6.5.2	Setting Up for Reflected Light Darkfield Microscopy Using the KÖHLER Method.....	96
6.5.3	Setting Up for Reflected Light DIC Microscopy	97
6.5.4	Setting Up for Reflected Light C-DIC Microscopy	98
6.5.5	Setting Up for Reflected Light TIC Microscopy	99
6.5.6	Setting Up for Reflected Light Polarization Microscopy – Proof of Birefractance and Reflection	101
6.5.7	Setting Up for Reflected Light Fluorescence Microscopy	102
6.6	Parfocality Function.....	104
6.6.1	Enabling/Disabling Parfocality.....	104
6.6.2	Using Parfocality	104
6.6.3	Calibrating Parfocality	104
6.7	Switching Off the Microscope	105
7	Care and Maintenance.....	106
7.1	Safety during Cleaning and Maintenance	106
7.2	Maintenance Schedule	107
7.3	Maintenance Work.....	108
7.3.1	Cleaning an Optical Surface.....	108
7.3.2	Removing Water-Soluble Contamination	108
7.3.3	Exchanging the 12 V, 50 W Halogen lamp of the HAL 50 Halogen Illuminator	109
7.3.4	Recovering the Stage Travel Range in X-Axis	110
7.3.5	Exchanging the Fuses T 15A H 250V in the Stand.....	110
8	Troubleshooting	111
8.1	Resetting the Microscope to the Factory Settings	115

9	Decommissioning and Disposal	116
9.1	Decommissioning	116
9.2	Transport and Storage.....	116
9.3	Disposal	117
9.4	Decontamination.....	117
10	Technical Data and Conformity	118
10.1	Performance Data and Specifications.....	118
10.2	Applicable Standards and Regulations	121
10.3	Usability of LED Modules for the Colibri 3 LED Light Source.....	122
11	Accessories and System Expansions	123
11.1	Binocular Tube	125
11.1.1	Binocular Tube 30°/23.....	125
11.1.2	Binocular Photo Tube Pol 20°/23 (100:0/0:100).....	126
11.1.3	Binocular Ergo Photo Tube 20°/23 (100:0/0:100)	127
11.1.4	Binocular Ergo Photo Tube 15°/23 (50:50)	128
11.1.5	Binocular Photo Tube 30°/23 (98:2), Reversed Image	129
11.1.6	Binocular Photo Tube 30°/23 (100:0/30:70/0:100), Reversed Image	130
11.2	Light Sources.....	131
11.2.1	HAL 100 Light Source.....	131
11.2.2	HBO 100	139
11.2.3	HXP 120 V	144
11.2.4	LED 10 Light Source	144
11.2.5	Colibri 3 LED Light Source	146
11.2.6	Viluma 5/7	149
11.3	Assembling the Reversible Eyecups	150
11.4	Analyzer Sliders	151
11.4.1	Analyzer Slider TL/RL, Fixed	151
11.4.2	Analyzer Slider TL/RL, with Lambda Plate, 360° Rotatable	151
11.4.3	Analyzer Slider TL/RL with Lambda Plate, each Rotatable +/- 10°	151
11.5	DIC Slider C 6x20	152
11.6	Stop Sliders for Aperture and Luminous-Field Diaphragms	152
11.7	Stages	153
11.7.1	Mechanical Stage, 75x50/240° Rotatable	153
11.7.2	Rotary Stage Pol 360° with Clamping Device.....	155
11.7.3	Adjusting the Drive Length on the Stage Drive	157
11.7.4	Removing the Additional Sleeves on the Ergonomic Stage Drive	157
11.7.5	Adjusting the Friction of the Coaxial Knurled Knobs on the Stage Drive.....	158
11.7.6	Adjusting the Friction of the Coaxial Knurled Knobs on the Ergonomic Stage Drive.....	158
11.8	Loading the Reflector Module	159
11.8.1	Assembling Reflector Modules	159
11.8.2	Exchanging the Filters of the Reflector Module FL P&C.....	160
11.8.3	Exchanging the Beam Splitter of the Reflector Module FL P&C	161
11.9	Loading the Condenser	163
11.9.1	Assembling the Modulator Disk in the Condenser 0.9 BF Pol	163
11.9.2	Assembling the Slit-Diaphragm for PlasDIC into the Modulator Disk	164
11.9.3	Changing PhC DIC PlasDIC Diaphragms on the 0.9 BF DF PhC DIC Achromatic-Aplanatic Condenser	165

11.10	Assembling the Sample Space Extension, 60 mm.....	165
11.10.1	Removing the Cover of the Upper Part of the Stand	166
11.10.2	Disconnecting the Cable Connections.....	166
11.10.3	Removing the Upper Part of the Stand	167
11.10.4	Assembling the Sample Space Extension	167
11.10.5	Assembling the Upper Part of the Stand on the Sample Space Extension	168
11.10.6	Establishing the Cable Connections	168
11.10.7	Assembling the Cover of the Upper Part of the Stand.....	169
11.11	Polarizers.....	169
11.11.1	Polarizer D, Fixed, Removable.....	169
11.11.2	Polarizer, Fixed, W-E $\pm 10^\circ$ adj.	170
11.11.3	Polarizer D, 90°, Rotatable, Removable	170
11.11.4	Polarizer, 90°, W-E $\pm 10^\circ$ adj.....	170
11.11.5	Polarizer, Fixed, with Lambda Plate, Rotatable.....	171
11.11.6	Polarizer, Rotatable, with Color Filter Carrier	171
11.11.7	Polarizer, 90°,W-E $\pm 10^\circ$ adj.,w. Filter Carrier	172
11.11.8	Circular Polarizer D.....	172
11.11.9	360-degree Rotatable Polarizer	173
11.11.10	Color Filter Carrier 3x for Filter d=32mm.....	173
11.11.11	Installing Polarizer or Color Filter Carrier on the Condenser Carrier.....	174
11.11.12	Polarizer on Field Aperture.....	175
11.11.13	Installing the Polarizer on the Field Aperture.....	175
11.11.14	Low-power System for Objectives 2.5x/4x	176
11.12	Assembling the Pol Components	178
11.12.1	Assembling the Pol Object Guide.....	178
11.12.2	Assembling the Focusable Pol Eyepiece	178
11.12.3	Centering the Objectives of the Polarization Stand	179
11.13	Axiocam 203 Mono/212 Color	180
11.13.1	Assembling the Axiocam 203 mono or Axiocam 212 color	181
11.13.2	Operating Modes Using the Axiocam 203 mono/212 color	182
11.14	Condenser, achromatic-aplanatic 0.9 BF DF PhC DIC	188
11.14.1	Assembling the Condenser, Chromatic-aplanatic 0.9 BF DF PhC DIC.....	188
11.14.2	Centering the Darkfield Diaphragm of the Condenser.....	189
11.14.3	Centering the Annular Phase Diaphragm of the Condenser	190
11.15	Assembling the Intermediate Plate for Analyzer Slider	191
11.16	Assembling the Tube Lens Turret.....	191
11.17	Assembling and Adjusting the Magnification Changer 4x	192
11.18	Exchanging the Filters in the Filter Wheel for Transmitted Light.....	192
11.19	Dual Observation.....	193
11.19.1	Preparing the Binocular Tubes	194
11.19.2	Assembling the Dual Observation	196
11.19.3	Operating the Dual Observation	197
	Revision History.....	198
	Glossary.....	199
	Index	200

1 Contact and Addresses

ZEISS Contact Find your contact at ZEISS Microscopy at www.zeiss.com/microscopy/contact.



ZEISS Academy For information on microscopy courses, training, and education visit the ZEISS Academy Microscopy at www.zeiss.com/microscopy-training.



**Legal
Manufacturer**



Carl Zeiss Suzhou Co., Ltd.
No. 26 Wusheng Road, SIP
215126 Suzhou
China

Authorized Representatives, Importers, etc. This section informs about responsible entities for certain obligations in the identified country or jurisdiction.



Carl Zeiss Microscopy GmbH
Carl-Zeiss-Promenade 10
07745 Jena
Germany



Carl Zeiss AG
Feldbachstrasse 81
8714 Feldbach
Switzerland

UK Responsible Person / UK Importer



Carl Zeiss Ltd
1030 Cambourne Business Park, Cambourne
CB23 6DW Cambridge
United Kingdom

Carl Zeiss LLC
Masanchi 78
050000 Almaty
Kazakhstan

2 About this Instruction Manual

This Instruction Manual (further called "document") is considered to be part of the Axioscope 5, Axioscope 5/7 MAT, herein after referred to as "microscope".

This document contains basic steps and safety information that must be observed during operation and maintenance. Therefore, the document must be read by the operator prior to commissioning and must always be available at the place of use of the microscope.

This document is an essential part of the microscope and, if the microscope is resold, the document must remain with the microscope or be handed over to the new owner.

2.1 Text Conventions and Link Types

Explanation	Example
Software controls and GUI elements.	Click Start .
Hardware controls and elements.	Press the Standby button.
Key on the keyboard.	Press Enter on the keyboard.
Press several keys on the keyboard simultaneously.	Press Ctrl + Alt + Del .
Follow a path in the software.	Select Tools > Goto Control Panel > Airlock .
Text to be entered by the user.	Enter <i>example.pdf</i> in this field.
Anything typed in literally during programming, for example macro codes and keywords.	Enter <code>Integer</code> in the console.
Link to further information within this document.	See: <i>Text Conventions and Link Types</i> [▶ 9].
Link to a website.	https://www.zeiss.com

2.2 Explanation of Warning Messages and Additional Information

DANGER, WARNING, CAUTION, and NOTICE are standard signal words used to determine the levels of hazards and risks of personal injury and property damage.

Always observe the safety and warning messages in **all** chapters of this document. Failure to comply with these instructions and warnings may result in personal injury, property damage, and the loss of any claims for damages.

The following warning messages indicating dangerous situations and hazards are used in this document.

DANGER

Type and source of danger

DANGER indicates an imminently hazardous situation which, if not avoided, will result in death or serious injury.

WARNING

Type and source of danger

WARNING indicates a potentially hazardous situation which, if not avoided, may result in death or serious injury.

CAUTION

Type and source of danger

CAUTION indicates a potentially hazardous situation which, if not avoided, may result in minor or moderate injury.

NOTICE













Type and source of danger

NOTICE indicates a potentially harmful situation which, if not avoided, may result in property damage.

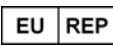
Info

Provides additional information or explanations to help the user better understand the contents of this document.

2.3 Explanation of Symbols

	CE marking (Conformité Européenne)
	UKCA marking (UK conformity assessed)
	CSA label: product tested by CSA to meet U.S. and Canadian standards. CSA approval master number optionally given adjacent to this symbol
	Manufacturer
	Country of manufacture. "CC" is the country code, e.g. "DE" for Germany, "CN" for China. Date of manufacture optionally given adjacent to this symbol
	Importer
	Authorized representative in the European Community
	Swiss authorized representative
	In vitro diagnostic medical device
	Serial number
	Catalogue number
	WEEE label: Do not discard as unsorted waste. Send to separate collection facilities for recovery and recycling

2.4 Further Applicable Documents

- Brochures and Certificates** For brochures, certificates (e.g. ISO, CSA, SEMI), and declarations of conformity (e.g. EU, UK) ask your ZEISS Sales & Service Partner.
- Local and National Health and Safety Regulations** Observe local and national health and safety regulations for the location of installation and during the use of the microscope.
- Safety Data Sheets** Consult with your ZEISS Sales & Service Partner if these regulations are in conflict with the installation requirements of the microscope.
- System and Third-Party Components, Accessories** Observe the enclosed safety data sheets. The instructions and guidelines given in the respective safety data sheets must be complied with.
- System and Third-Party Components, Accessories** Information about the individual components, enhancements, and accessories can be obtained from your ZEISS Sales & Service Partner. Also refer to the documentation of third-party manufacturers.
- Instruction Manuals** For detailed information refer to the following Instruction Manuals of:
- Axiocam 212 color
 - Axiocam 203 mono
 - Light sources (e.g. HBO 100, HXP 120 V, HAL 100, HAL 50, Colibri 3, Viluma 5/7)
 - Mechanical stage, 80X60, motorized

3 Safety

This chapter contains general requirements for safe working practices. Any person using the microscope or commissioned with installation or maintenance must read and observe these general safety instructions. Knowledge of basic safety instructions and requirements is a precondition for safe and fault-free operation. Operational safety of the supplied microscope is only ensured if it is operated according to its intended use.

If any work is associated with residual risks, this is mentioned in the relevant parts of this document in a specific note. When components must be handled with special caution, they are marked with a warning label. These warnings must always be observed.

Improper use of the microscope and its components can easily lead to impairment of their function or even damage them. Damage caused by incorrect operation, negligence, or unauthorized intervention, in particular by removing, modifying, or replacing parts of the microscope or its components, cannot be held liable by the device manufacturer. Third-party devices or components that are not expressly approved by ZEISS may not be used.

Any serious incident that has occurred in relation to the microscope and its components shall be reported to these institutions:

- the competent authority of the Member State in which the user is established
- ZEISS
 - for users within the EU:
Carl Zeiss Microscopy GmbH, Jena, Germany
 - for users outside the EU:
Carl Zeiss Suzhou Co., Ltd., Suzhou, China

3.1 Intended Purpose

The Axioscope 5/7 BIO microscopes are non-automatic microscopes for general microscopic imaging for the in vitro examination of various samples, such as tissue or blood, derived from the human body that are mounted on microscopic glass slides. Axioscope 5/7 BIO must be operated by qualified users like medical technical assistants or pathologists. The observation of the sample through the microscope is intended to aid in routine diagnostics by providing qualitative information for subsequent assessment of physiological or pathological processes or conditions by qualified users such as pathologists, cytologists or hematologists. The microscope is not intended for direct diagnosis, screening, monitoring, prognosis, prediction, companion diagnostic, blood grouping, tissue typing, and detection.

Axioscope 5/7 BIO microscopes include:

- Axioscope 5 TL (430035-9201-000)
- Axioscope 5 TL HAL 50 (430035-9032-000)
- Axioscope 5 TL/FL (430035-9061-000)
- Axioscope 7 TL (430035-9310-000)
- Axioscope 7 TL/FL (430035-9320-000)

The Axioscope 5/7 MAT microscopes are universally usable microscopes for applications such as materials analyses. It is not intended to either directly or indirectly generate medical diagnostic results.

Axioscope 5/7 MAT microscopes include:

- Axioscope 5 RL (430035-9091-000)
- Axioscope 5 TL/RL (430035-9121-000)
- Axioscope 5 TL/RL Pol (430035-9291-000)
- Axioscope 5 TL Pol (430035-9261-000)
- Axioscope 7 RL (430035-9340-000)
- Axioscope 7 TL/RL MAT (430035-9330-000)
- Axioscope 5 Vario (430035-9150-000)

Info

The catalogue number can be found on the type plate, see *Labels and Lights* [▶ 20].

3.2 General Safety Information

This document must be read before commissioning in order to ensure safe and uninterrupted operation. Pay particular attention to all listed safety notes. Make sure, that

- the operating personnel has read and understood this manual, associated documents and particularly all safety regulations and instructions, and applies them.
- the local and national safety and accident prevention regulations must be observed, as well as the applicable laws and regulations in your country.
- this document is always available at the place of use of the microscope.
- the microscope is always in perfect condition.
- in case of defect or damage, the affected parts and the microscope are taken out of operation immediately and are secured against unintentional use.
- maintenance and repair work, retrofitting, removal or replacement of components, as well as any other intervention in the microscope not described in this document, may only be carried out by the manufacturer ZEISS or persons expressly authorized by ZEISS to do so.

3.2.1 Requirements for Operators

The microscope, components, and accessories may only be operated and maintained by authorized and trained personnel. The microscope may only be used in accordance with this document. If the microscope is not used as described, the safety of the user may be impaired and/or the microscope may be damaged.

Any unauthorized intervention or use other than within the scope of the intended use shall void all rights to warranty claims. The regional regulations on health protection and accident prevention must be observed at all times and during all work on and with the microscope.

Training Authorized ZEISS personnel will provide basic training in operating the microscope, as well as information on equipment safety and maintenance work that can be conducted by the operator. The training will be documented by ZEISS and its completion is to be confirmed by the operator.

Special application training is offered for a fee. Current training dates, additional information and the registration form can be found at www.zeiss.com or at the [ZEISS Portal](#).

3.2.2 Safe Operating Condition

If circumstances occur which impair safety and cause changes in operating behavior, the microscope and its components must be shut down immediately and a ZEISS service representative should be informed.

The microscope may only be operated if the operating conditions are adhered to.

- Do not operate the microscope and its components until you have completely read and understood the entire documentation.
- Make sure that all protective cover panels are installed and all warning labels are available and legible.
- Ensure conditions and take measures to prevent the build up of electrostatic charge on the workplace.

3.2.3 Order and Use of Spare Parts

Using spare parts that are not provided by ZEISS can be hazardous or can lead to property damage.

- Unless authorized by ZEISS, all spare parts should be installed by a ZEISS service representative.
- Contact your ZEISS service representative for information on spare parts order.
- Only genuine parts supplied by ZEISS are to be used in servicing the microscope and its components.

3.2.4 Lifetime

A microscope is an opto-electronic device. Its availability for use is significantly determined by the performed maintenance. ZEISS guarantees the ability for maintenance and repair within eight years after initial operation. This is ensured by a corresponding service and spare parts concept, thus enabling the intended purpose within this duration.

3.2.5 Optical Risk Grouping

According to IEC 62471 sources of optical radiation are classified into risk groups subject to their potential photobiological hazard. Sources are classified into the following four groups according to hazard, based on the emission limit as well as permissible exposure time before hazard exceeded.

Risk group	Description
Exempt	No photobiological hazard.
1 (low risk)	No hazard due to normal behavioral limitations on exposure.
2 (moderate risk)	No hazard due to the aversion response to very bright light sources or thermal discomfort.
3 (high risk)	Hazardous even for momentary exposure.

The following table lists the risk grouping of the available light sources/illumination units according to the mentioned standard:

Light source/Illumination unit	Risk group
Colibri 3	3
Viluma 5/7	3
HBO 100	2
HXP 120 V	2
LED modules	2
HAL 100	2
HAL 50	1

3.2.6 EMC Information

3.2.6.1 Axioscope 5/7 BIO

The following EMC information is valid for the Axioscope 5/7 BIO microscopes. For a definition of the included microscopes, see *Intended Purpose* [▶ 13].

The microscope is intended to be used in an industrial electromagnetic environment for non-clinical applications or in a home healthcare environment for clinical applications.

Use of this microscope in a dry environment, especially if synthetic materials are present (synthetic clothing, carpets, etc.), may cause electrostatic discharges that may cause erroneous results.

Do not use the microscope in proximity to sources of strong electromagnetic radiation, as these can interfere with proper operation.

If it is suspected that performance is affected by electromagnetic interference, correct operation may be restored by increasing the distance between the equipment and the source of the interference.

The microscope complies with the emission and immunity requirements as a CISPR 11 / EN 55011 / class B group 1 system according to IEC 61326-1 and IEC 61326-2-6. Emissions, which exceed the levels required by CISPR 11 / EN 55011, can occur when the microscope is connected to other devices.

The electromagnetic environment should be evaluated prior to operation of the microscope.

The following EMC user notice is for Canada only:

This device complies with CAN ICES-001 (B) / NMB-001 (B).

The following EMC user notice is for Korea only:

기종별	사용자안내문
B급기기 (가정용 방송통신기자재)	이 기기는 가정용(B급) 전자파적합기기로서 주로 가정에서 사용하는 것을 목적으로 하며, 모든 지역에서 사용할 수 있습니다.

3.2.6.2 Axioscope 5/7 MAT

The following EMC information is valid for the Axioscope 5/7 MAT microscopes, except Axioscope 5 Vario. For a definition of the included microscopes, see *Intended Purpose* [▶ 13].

The microscope is intended to be used in an industrial electromagnetic environment.

The microscope complies with the emission and immunity requirements as a CISPR 11 / EN 55011 / class B group 1 system according to IEC 61326-1. Emissions, which exceed the levels required by CISPR 11 / EN 55011, can occur when the microscope is connected to other devices.

The following EMC user notice is for Canada only:

This device complies with CAN ICES-001 (B) / NMB-001 (B).

The following EMC user notice is for Korea only:

기종별	사용자안내문
B급기기 (가정용 방송통신기자재)	이 기기는 가정용(B급) 전자파적합기기로서 주로 가정에서 사용하는 것을 목적으로 하며, 모든 지역에서 사용할 수 있습니다.

3.2.6.3 Axioscope 5 Vario

The following EMC information is valid for the Axioscope 5 Vario microscope.

The microscope is intended to be used in an industrial electromagnetic environment.

The microscope complies with the emission and immunity requirements as a CISPR 11 / EN 55011 / class A group 1 system according to IEC 61326-1. Emissions, which exceed the levels required by CISPR 11 / EN 55011, can occur when the microscope is connected to other devices.

The following EMC user notice is for Canada only:

This device complies with CAN ICES-001 (A) / NMB-001 (A).

The following EMC user notice is for Korea only:

기종별	사용자안내문
A급기기(업무용방송통신기자재)	이기기는업무용(A급) 전자파적합기기로서 판매자또는사용자는이점을주의하시기바라며, 가정용 환경에서 사용하는 경우 전파간섭의 우려가 있습니다.

3.3 Prevention of Hazards

This section summarizes potential hazards and recommended safety precautions. Failure to follow the safety instructions and instructions may result in personal injury and property damage.

3.3.1 Mechanical Hazards

Crushing Hazards due to Motorized Components

The microscope contains motorized components. Fingers could be trapped. Do not reach into the working area of motorized components when they are in operation.

Property Damage due to Transport

There is a risk of injury and property damage if the microscope is improperly handled and transported.

- Only use the handle, if applicable, for transport of the microscope. Otherwise hold the microscope with one hand and the base plate with the other hand.
- The weight of the Axioscope ranges from 14 to 32 kg, depending on the configuration. Handle it carefully with both hands or with two people together.

3.3.2 Electrical Hazards

Voltage Hazards

Risk of electric shock in case of contact with live parts.

- Detachable mains supply cords must not be replaced with inadequately rated cords.
- Disconnect all power cords before cleaning.
- Only connect electrical systems that are authorized by ZEISS to the supplied power supply cord.
- Set up and operate the microscope so that the connectors are easily accessible.
- Position the microscope in a way so that you can easily unplug the power cord at any time.
- The microscope must be plugged into a properly installed power socket with protective earth contact using the supplied mains cords. The protective earth connection must not be impaired by the use of extension cables.
- Always use the power cords supplied by ZEISS. When an unsuitable power cord is used, ZEISS can no longer guarantee the electrical safety and functionality of the microscope.
- Shut down the microscope when not using the microscope.
- Safe disconnection from the power supply is only ensured by pulling out the power cord. The switch on the microscope only switches to standby mode.

3.3.3 Hazards Generated with the Operating Environment

Explosive Hazard Fire hazard due to explosive or flammable environment.

Do not operate the microscope and its components in a potentially explosive atmosphere, in the presence of volatile anesthetics or flammable solvents such as alcohol, petrol, or similar substances.

Dirt, Dust, and Moisture Dirt, dust, and moisture can impair the microscope's functionality.

- Shut down the microscope whenever it is not used and cover it with a dust protection cover (if available).
- Always cover unused openings/ports with the corresponding system component or with blind caps.
- Perform regular maintenance and cleaning according to the instructions in this manual.
- Make sure that no cleaning liquid or moisture gets inside the microscope.
- Make sure that the electrical parts never come into contact with moisture.
- Never expose the microscope to inadmissible climate conditions (high humidity and temperature).

3.3.4 Ergonomic Hazards

Prevention of Musculoskeletal Disorders Musculoskeletal disorders (MSDs) affect the muscles, nerves, blood vessels, ligaments and tendons. Workers in many different industries and occupations can be exposed to risk factors at work, such as lifting heavy items, bending, reaching overhead, pushing and pulling heavy loads, working in awkward body postures and performing the same or similar tasks repetitively. Employers are responsible for providing a safe and healthful workplace for their workers.

3.3.5 Hazards Generated by Materials and Substances

Infection Hazards Direct contact with the eyepieces can be a potential way of passing on bacterial and viral infections.

- The risk can be lowered by using personal eyepieces or eyecups. If eyepieces need to be disinfected frequently, ZEISS recommends to use the eyepieces without eyecups.
- To avoid infections, the use of personal protective equipment (PPE), e.g. gloves, for operation, cleaning, and decontamination is highly recommended. Disposable gloves can be decontaminated with alcohol for example, if necessary, or should be changed frequently to minimize the risk of contamination.

Biological Hazard Biological substances/agents may pose a risk to the health of humans and other living organisms.

- Keep a logbook of the known biological substances/agents used when working with the microscope and show it to the ZEISS service representative before they perform any work on the microscope.

Consumable Hazards Incorrect handling of consumables and cleaning agents can lead to property damage or skin and eye injuries. Consumables that are not approved by ZEISS can lead to property damage. Consult your ZEISS Sales & Service Partner to learn what consumables you can order and how to handle them.

Immersion Oil Ensure that no immersion oil enters the surface water or the sewage system. The immersion oil can cause skin irritation.

- Avoid any contact with skin, eyes and clothes.
- Read and observe the safety data sheet of the immersion fluid.
- In the event of skin contact, wash the oil off with plenty of water and soap.
- In the event of eye contact, flush eyes with copious amounts of water for a minimum of 5 minutes. See a medical specialist if the irritation persists.

- Hazardous Substances** The microscope and other components can come into contact with various samples and substances that can be hazardous to humans and the environment. The microscope is not equipped with special user protection against substances that are corrosive, potentially infectious, toxic, radioactive or otherwise hazardous to health. When handling such substances, make sure to observe all legal regulations, particularly the relevant national accident prevention regulations.
- Make sure that the microscope and its components was not in contact with hazardous substances (check the laboratory logbook); otherwise, the microscope and its components must be cleaned/decontaminated/disinfected.
 - Label contaminated/infected components that cannot be properly cleaned.
 - Direct contact with the eyepieces (if applicable) can be a potential way of passing on bacterial and viral infections. The risk can be lowered by using personal eyepieces or eyecups. If eyepieces need to be disinfected frequently, ZEISS recommends to use eyepieces with eyeglass protection rings instead of foldable eyepieces.
 - Contaminated parts shall not be returned to any ZEISS department. Decontaminated parts can be sent to ZEISS accompanied by a signed „Customer Declaration of Decontamination“.
 - Wear personal protective equipment if necessary.

3.3.6 Hazards Generated by Radiation

Optical Radiation Hazards Gas discharge lights, LED lights and other sources of white light emit strong optical radiation (e.g. UV, VIS, IR). Optical radiation may cause damage to the skin and eyes. The extent of the damage depends on the parameters such as wavelength, exposure time, mode of operation (continuous or pulsed), etc.

- Avoid exposure of eyes and skin to radiation.
- Do not introduce reflective objects into the beam path.
- Never remove covers or cover panels during operation.
- Do not disable any interlock system elements.
- Use suitable protective equipment / protective clothing if required.

Electromagnetic Radiation Hazards The microscope may cause radio interference, which may be mitigated by relocating or re-orienting the equipment. The use of non-specified accessories, cables, or other auxiliary parts from the field of information technology may lead to increased electromagnetic emissions and reduced immunity to interference. Any integration into the system may result in a degradation of the EMC performance.

3.3.7 Thermal Hazards

Burning Hazards Hot surfaces, radiation and/or aggressive chemicals can cause burns.

- Use suitable protective equipment / protective clothing if mandatory.
- Always observe the cooling time of the hot surfaces.

Heat Accumulation Covering the ventilation openings can lead to heat accumulation that may damage the microscope and its components and, in extreme cases, can cause a fire.

- Keep ventilation openings unobstructed at all times.
- Do not cover devices or openings emitting heat.
- Comply with minimum distance from walls.

3.4 Labels and Lights

This chapter shows labels and, where applicable, indicator lights.

All parts that may pose specific hazards are marked with warning labels.

Always observe **all** warning labels!

- Check all warning labels for availability and legibility.
- Immediately replace damaged or illegible warning labels.

In case a label is missing, contact your ZEISS service representative for free of charge replacement.

3.4.1 Labels on the Axioscope

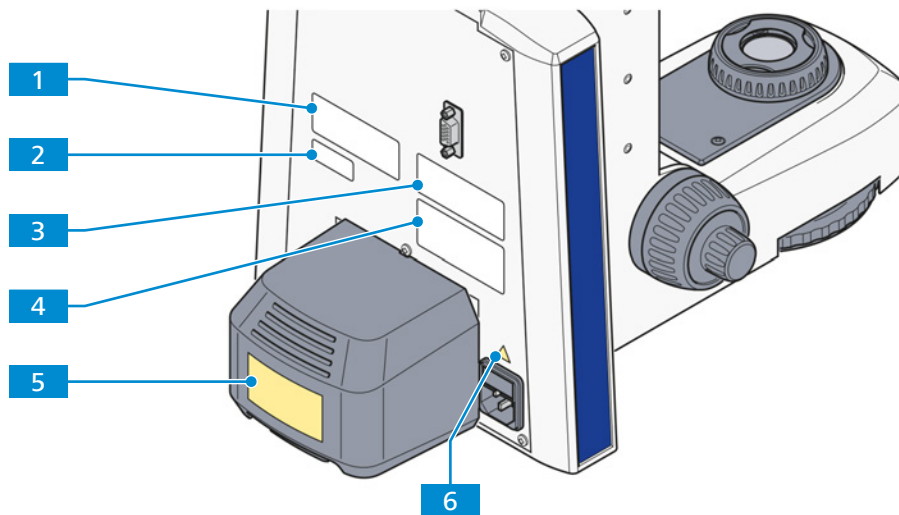
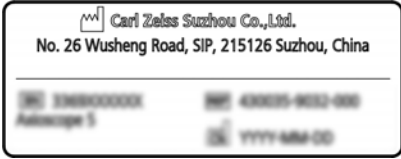



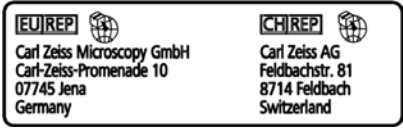





Fig. 1: Warning labels on microscopes with LED light source for transmitted light

Pos.	Symbol	Description
1		Microscope type label
2		Serial number label
3		Microscope type label valid for the Axioscope 5/7 BIO microscopes
		Microscope type label valid for the Axioscope 5/7 MAT microscopes

Pos.	Symbol	Description
4		Representatives and importer label not applicable for Axioscope 5/7 MAT microscopes
		Importer label only applicable for Axioscope 5/7 MAT microscopes
5		CAUTION LED Radiation Do not stare at operating lamp. May be harmful to the eyes.
6		Observe notes in the instruction manual and the supplied documents.

3.4.2 Labels on the motorized 80x60 Mechanical Stage

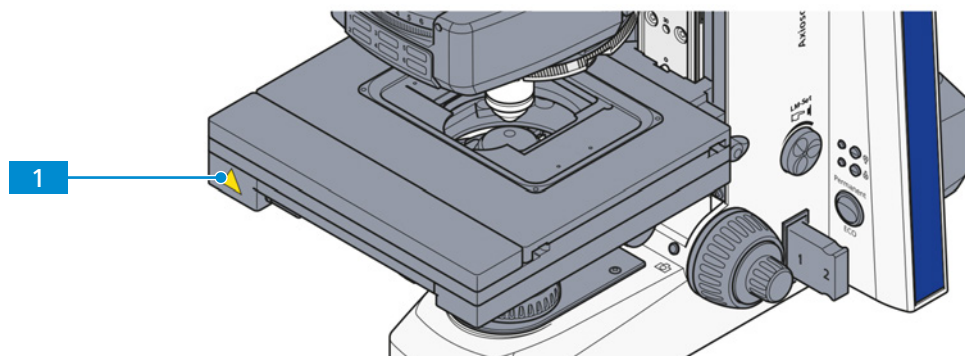



Fig. 2: Warning label on the motorized 80x60 mechanical stage

Pos.	Symbol	Description
1		Crushing Hazards Fingers may be pinched!

3.5 Safety Devices and Interlocks

In order to prevent injuries and/or property damage, the microscope and its components are equipped with several safety devices and interlocks. In case of defect or damage, the affected parts and the microscope must be taken out of operation immediately and must be secured against unintentional use.

To verify the safety of the microscope and its components, contact your ZEISS service representative and keep the service logs and logbooks.

4 Product and Functional Description

The Axioscope 5, Axioscope 5/7 MAT are microscopes designed for biological and medical applications as well as materials analyses. Depending on the configuration of the microscope stand, they may be used with transmitted light only or with a combination of transmitted light and reflected light.

Depending on the configuration of the microscope, the following microscopy and contrast techniques are available:

- | | |
|-------------------------------|---|
| Transmitted Light (TL) | <ul style="list-style-type: none"> ▪ <i>Brightfield (BF)</i> [▶ 56] ▪ <i>Darkfield (DF)</i> [▶ 56] ▪ <i>Phase contrast (PhC)</i> [▶ 56] ▪ <i>Differential Interference Contrast (DIC)</i> [▶ 56] ▪ <i>PlasDIC contrast</i> [▶ 57] ▪ <i>Polarization contrast (Pol): orthoscopy and conoscopy</i> [▶ 57] |
| Reflected Light (RL) | <ul style="list-style-type: none"> ▪ <i>Brightfield (BF)</i> [▶ 60] ▪ <i>Darkfield (DF)</i> [▶ 60] ▪ <i>Differential Interference Contrast (DIC)</i> [▶ 60] ▪ <i>Differential Interference Contrast in circularly polarized light (C-DIC)</i> [▶ 60] ▪ <i>Total Interference Contrast in circularly polarized light (TIC)</i> [▶ 60] ▪ <i>Polarization contrast (Pol)</i> [▶ 63] ▪ <i>Fluorescence contrast</i> [▶ 63] |

The following microscope types are available:

Axioscope 5 TL	Transmitted light stand for bioscience
Axioscope 5 TL HAL 50	Transmitted light stand for bioscience
Axioscope 5 TL/FL	Transmitted light and reflected light fluorescence stand for bioscience
Axioscope 5 RL	Reflected light stand for material
Axioscope 5 TL/RL	Transmitted light and reflected light stand for material
Axioscope 5 TL/RL Pol	Transmitted light and reflected light stand for polarization
Axioscope 5 TL Pol	Transmitted light stand for polarization
Axioscope 7 TL	Transmitted light stand for bioscience
Axioscope 7 TL/FL	Transmitted light and reflected light fluorescence stand for bioscience
Axioscope 7 RL	Reflected light stand for material
Axioscope 7 TL/RL MAT	Transmitted light and reflected light fluorescence stand for material
Axioscope 5 Vario	Transmitted and reflected light stand for material

- | | |
|-----------------------------|--|
| Typical Applications | <p>Axioscope 5/7 BIO</p> <ul style="list-style-type: none"> ▪ examination of blood and tissue samples taken from the human body, from plants, or animals ▪ medical examinations in laboratories, hospitals, and doctors' offices ▪ academic and practical education in medicine and biology ▪ industrial applications, e.g. in pharmacology, food technology, and wastewater examination |
|-----------------------------|--|

Axioscope 5/7 MAT

- metallographic laboratories
- automotive industry
- microsystems engineering
- geoscientific institutes
- mineral exploration industry

Info

Additional information about the hardware configuration and optional enhancements can be obtained from your ZEISS Sales & Service Partner.

4.1 Axioscope 5 TL

4.1.1 Main Components of Axioscope 5 TL

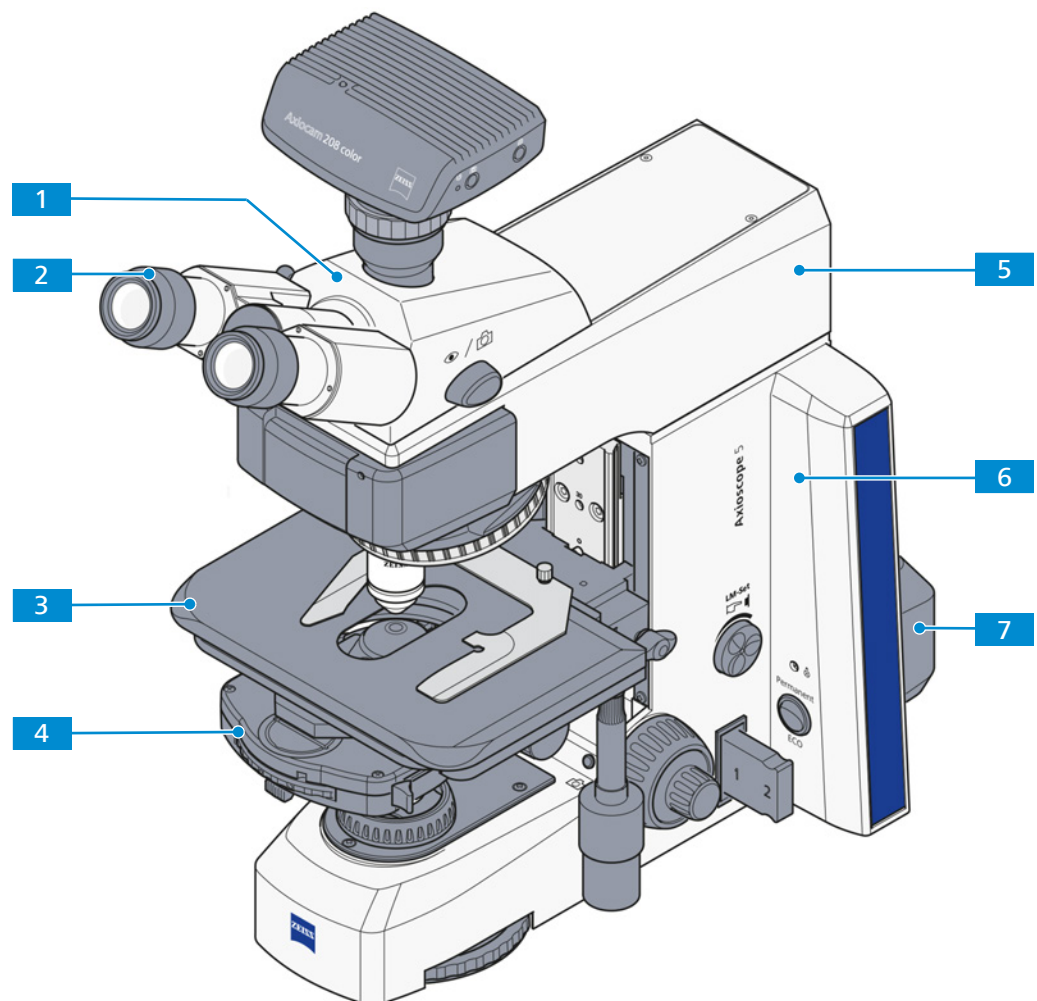

Fig. 3: Main components - Axioscope 5 TL

- | | |
|--|---|
| 1 Binocular tube [▶ 44] | 2 Eyepieces [▶ 48] |
| 3 Mechanical stage [▶ 52] | 4 Condenser [▶ 50] |
| 5 Upper part of the stand | 6 Lower part of the stand |
| 7 TL light source [▶ 131] | |

4.1.2 Controls and Functional Elements of Axioscope 5 TL

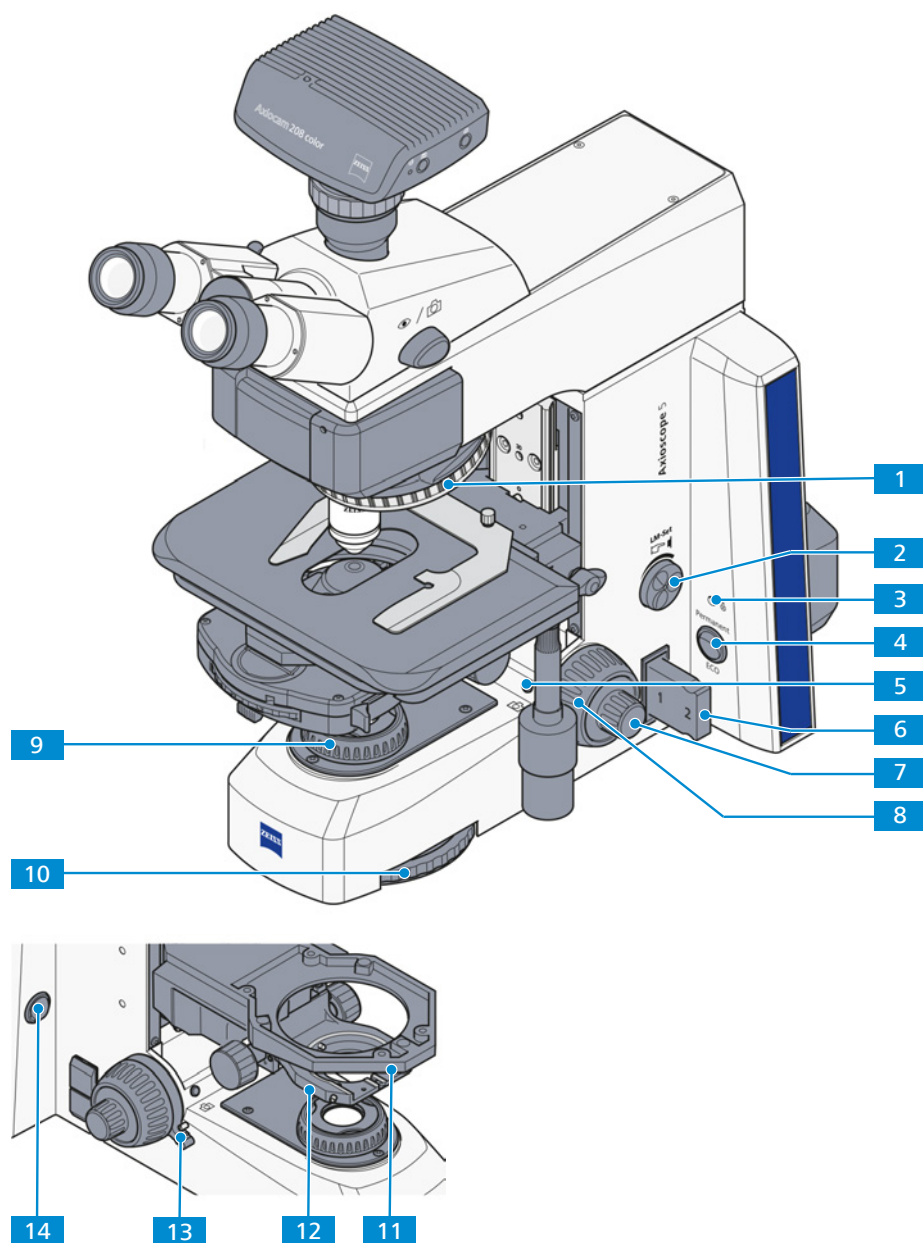

Fig. 4: Controls and functional elements - Axioscope 5 TL

- | | |
|--|--|
| 1 Nosepiece | 2 Intensity/LM knob for light intensity and Light Manager function |
| 3 Indicator light for transmitted light | 4 Permanent/ECO mode switch |
| 5 Snap buttons (left and right) | 6 Filter slider for transmitted light |
| 7 Focusing drive – fine adjustment (left and right) | 8 Focusing drive – coarse adjustment (left and right) |
| 9 Luminous-field diaphragm | 10 6-position filter wheel (operable from left and right) |
| 11 Stage carrier | 12 Condenser carrier |
| 13 Release lever for height stop on focusing drive | 14 Power switch On/Off |

4.2 Axioscope 5 TL/FL

4.2.1 Main Components of Axioscope 5 TL/FL

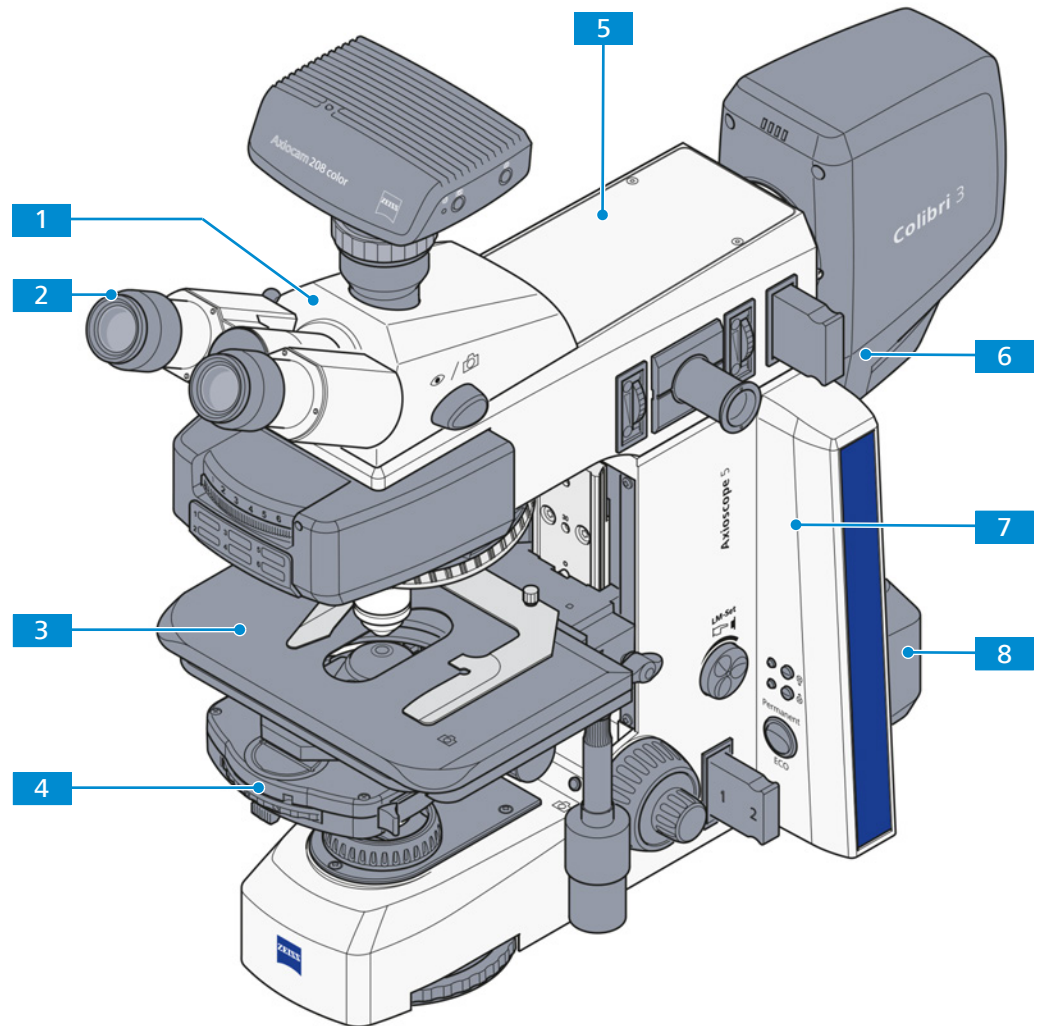

Fig. 5: Main components - Axioscope 5 TL/FL

- | | |
|--|--|
| 1 Binocular tube [▶ 44] | 2 Eyepieces [▶ 48] |
| 3 Mechanical stage [▶ 52] | 4 Condenser [▶ 50] |
| 5 Upper part of the stand | 6 RL light source for fluorescence |
| 7 Lower part of the stand | 8 TL light source [▶ 131] |

4.2.2 Controls and Functional Elements of Axioscope 5 TL/FL

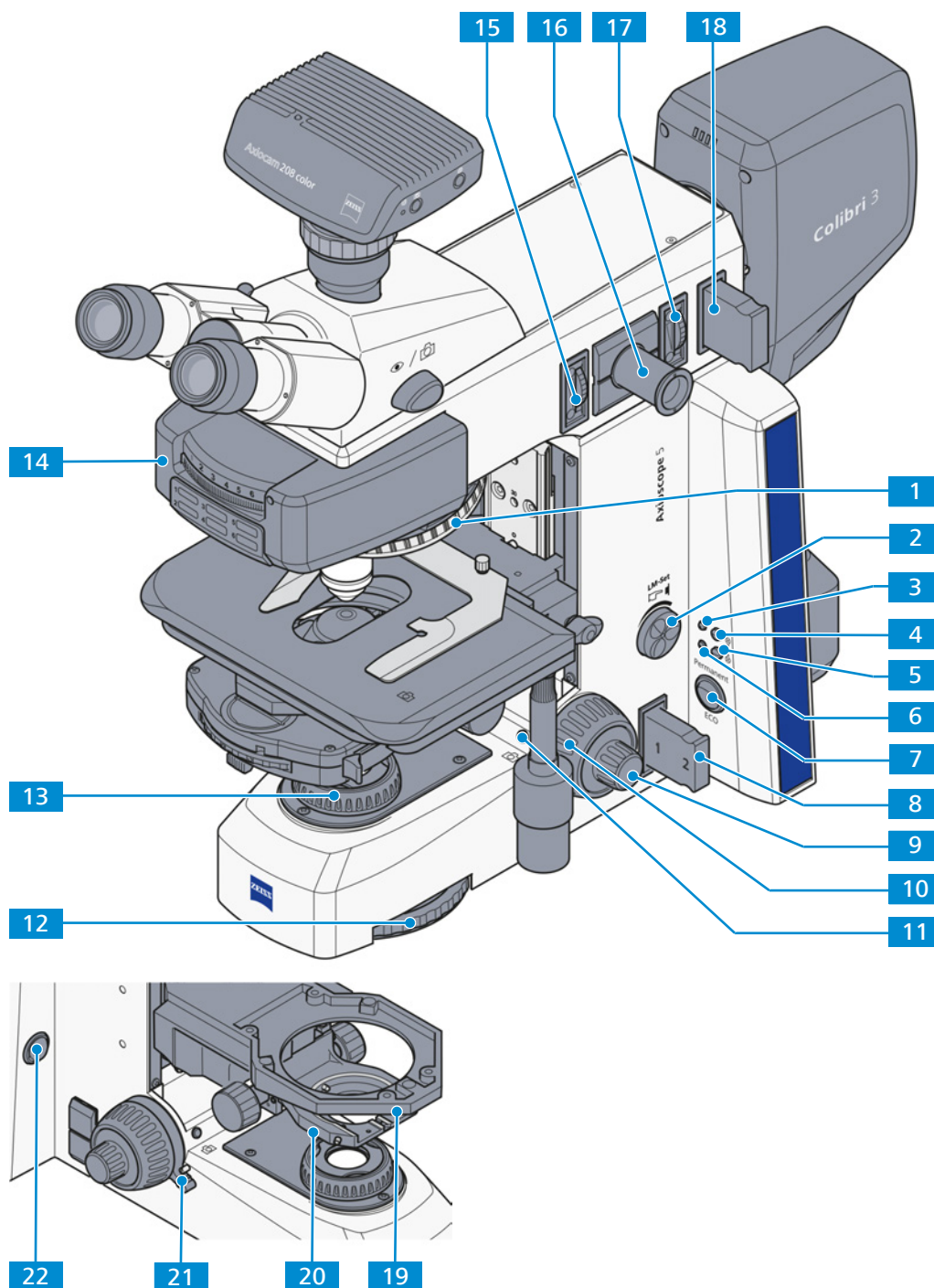

Fig. 6: Controls and functional elements - Axioscope 5 TL/FL

- | | |
|--|---|
| 1 Nosepiece | 2 Intensity/LM knob for light intensity and Light Manager function (LM) and switching between fluorescence channels |
| 3 Indicator light for reflected light | 4 Reflected light (RL) button |
| 5 Indicator light for transmitted light | 6 Transmitted light (TL) button |
| 7 Permanent/ECO mode switch | 8 Filter slider for transmitted light |
| 9 Focusing drive – fine adjustment (left and right) | 10 Focusing drive – coarse adjustment (left and right) |

- | | |
|---|--|
| 11 Snap buttons (left and right) | 12 6-position filter wheel (operable from left and right) |
| 13 Luminous-field diaphragm for transmitted light | 14 Reflector turret (for replaceable reflector modules) |
| 15 Luminous-field diaphragm for reflected light | 16 Adjustment tool |
| 17 Aperture diaphragm or FL attenuator for reflected light | 18 Filter slider for reflected light |
| 19 Stage carrier | 20 Condenser carrier |
| 21 Release lever for height stop on focusing drive | 22 Power switch On/Off |

4.3 Axioscope 5 TL/RL

4.3.1 Main Components of Axioscope 5 TL/RL and Axioscope 5 TL/RL Pol

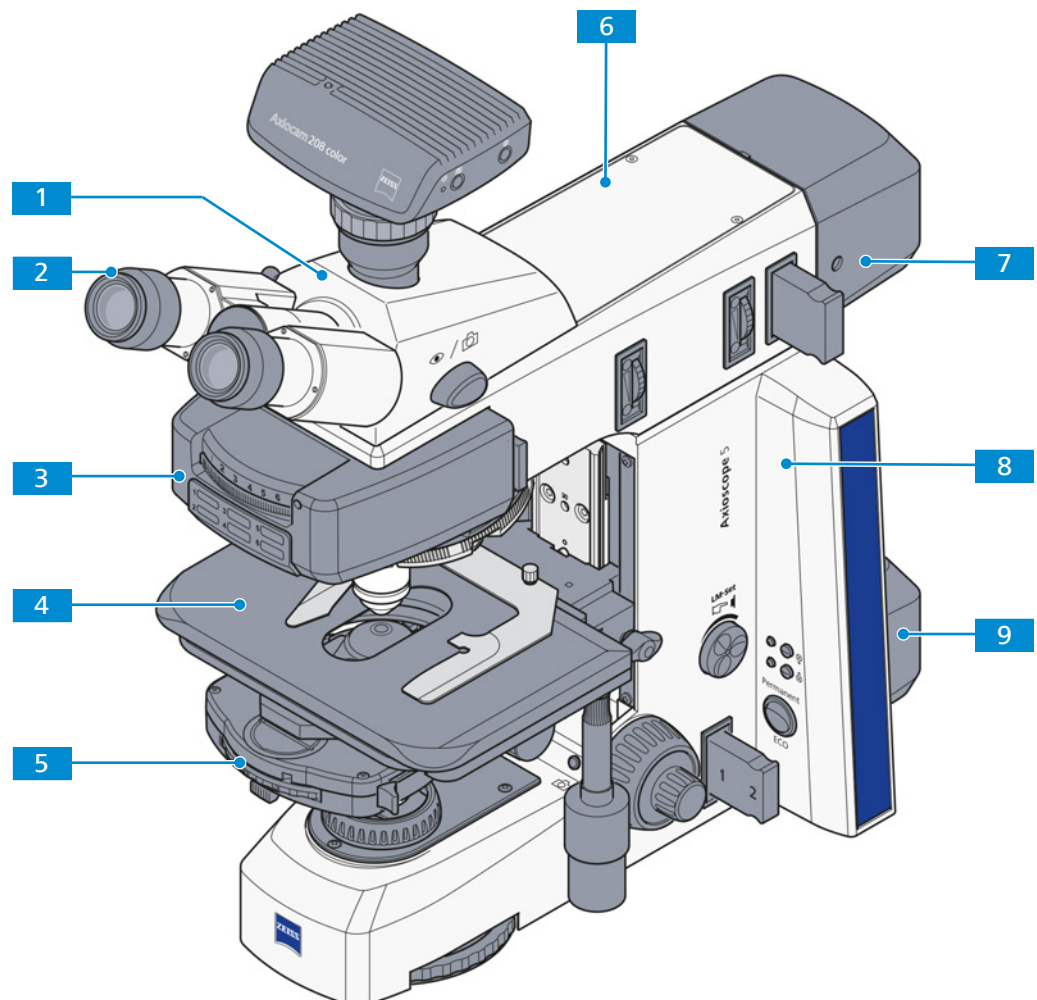

Fig. 7: Main components - Axioscope 5 TL/RL

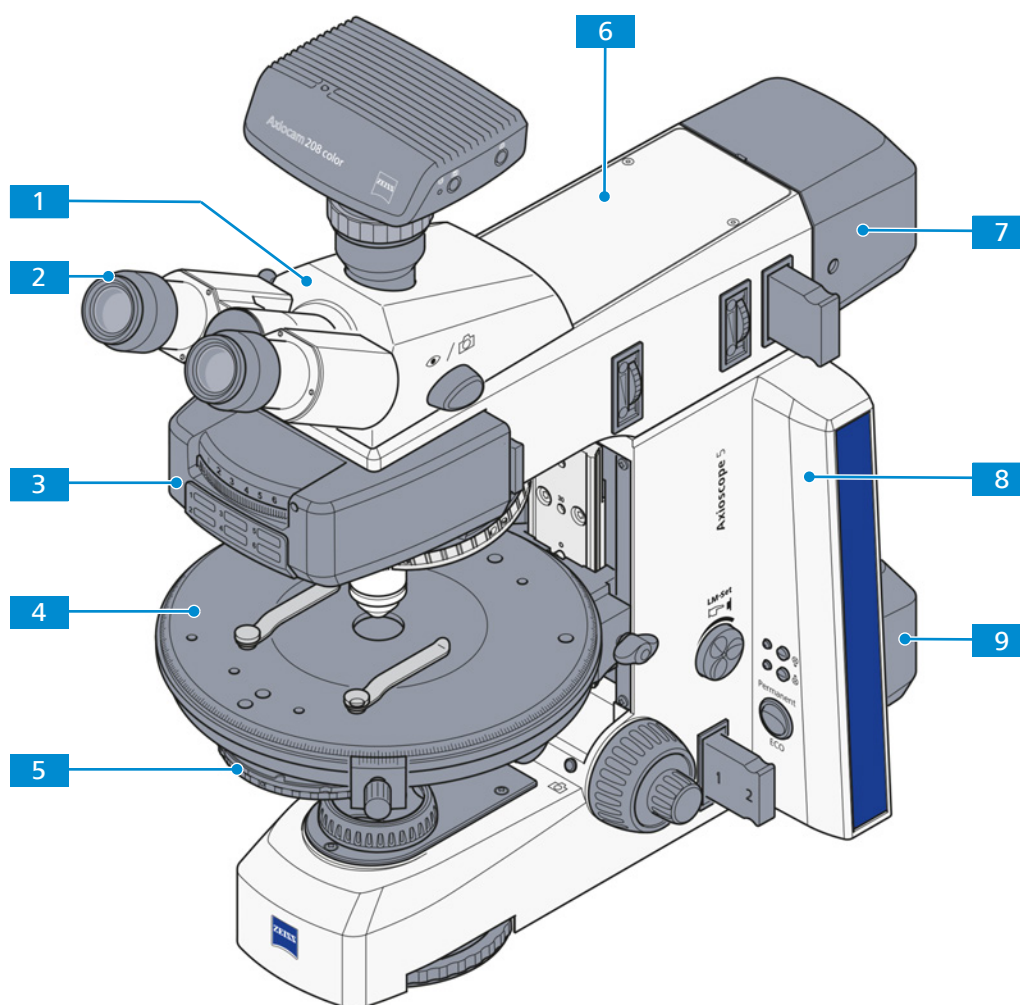

Fig. 8: Main components - Axioscope 5 TL/RL Pol

- | | |
|--|--|
| 1 Binocular tube [▶ 44] | 2 Eyepieces [▶ 48] |
| 3 Reflector turret [▶ 55] | 4 Mechanical stage [▶ 52]
Rotary stage [▶ 52]* |
| 5 Condenser [▶ 50] | 6 Upper part of the stand |
| 7 RL light source [▶ 131] | 8 Lower part of the stand |
| 9 TL light source [▶ 131] | |

*only with Axioscope 5 TL/RL Pol

4.3.2 Controls and Functional Elements of Axioscope 5 TL/RL and Axioscope 5 TL/RLPol

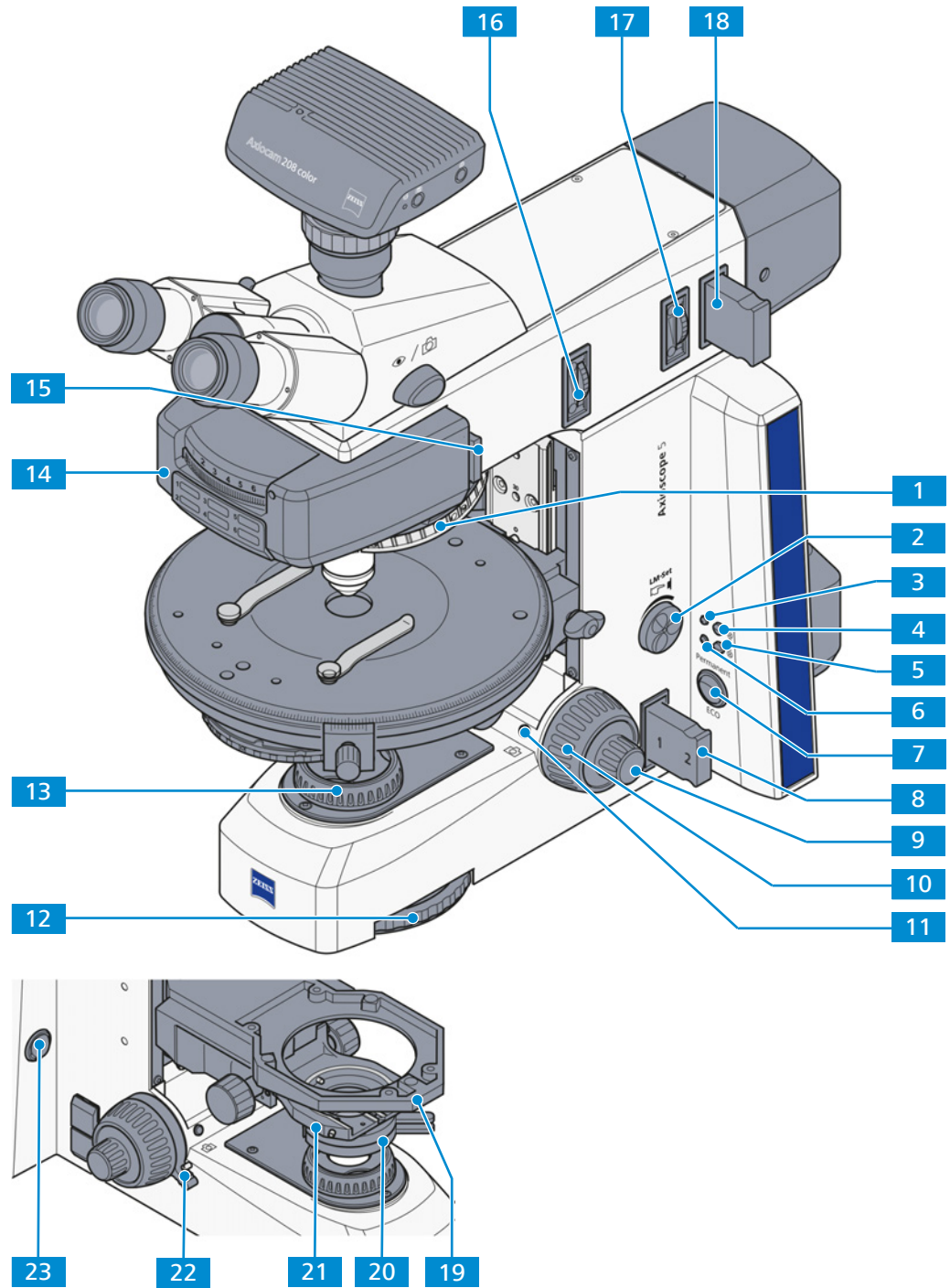

Fig. 9: Controls and functional elements - e.g. Axioscope 5 TL/RL Pol

- | | |
|--|---|
| 1 Nosepiece | 2 Intensity/LM knob for light intensity and Light Manager function (LM) and switching between fluorescence channels |
| 3 Indicator light for reflected light | 4 Reflected light (RL) button |
| 5 Transmitted light (TL) button | 6 Indicator light for transmitted light |
| 7 Permanent/ECO mode switch | 8 Filter slider for transmitted light |
| 9 Focusing drive – fine adjustment (left and right) | 10 Focusing drive – coarse adjustment (left and right) |
| 11 Snap buttons (left and right) | 12 6-position filter wheel (operable from left and right) |
| 13 Luminous-field diaphragm for transmitted light | 14 Reflector turret (for replaceable reflector modules) |
| 15 Slot for polarizer slider A 60x30 mm | 16 Luminous-field diaphragm for reflected light |
| 17 Aperture diaphragm for reflected light | 18 Filter slider for reflected light |
| 19 Stage carrier | 20 Polarizer * |
| 21 Condenser carrier | 22 Release lever for height stop on focusing drive |
| 23 Power switch On/Off | |

*only with Axioscope 5 TL/RL Pol

4.4 Axioscope 5 Vario

4.4.1 Main Components of Axioscope 5 Vario

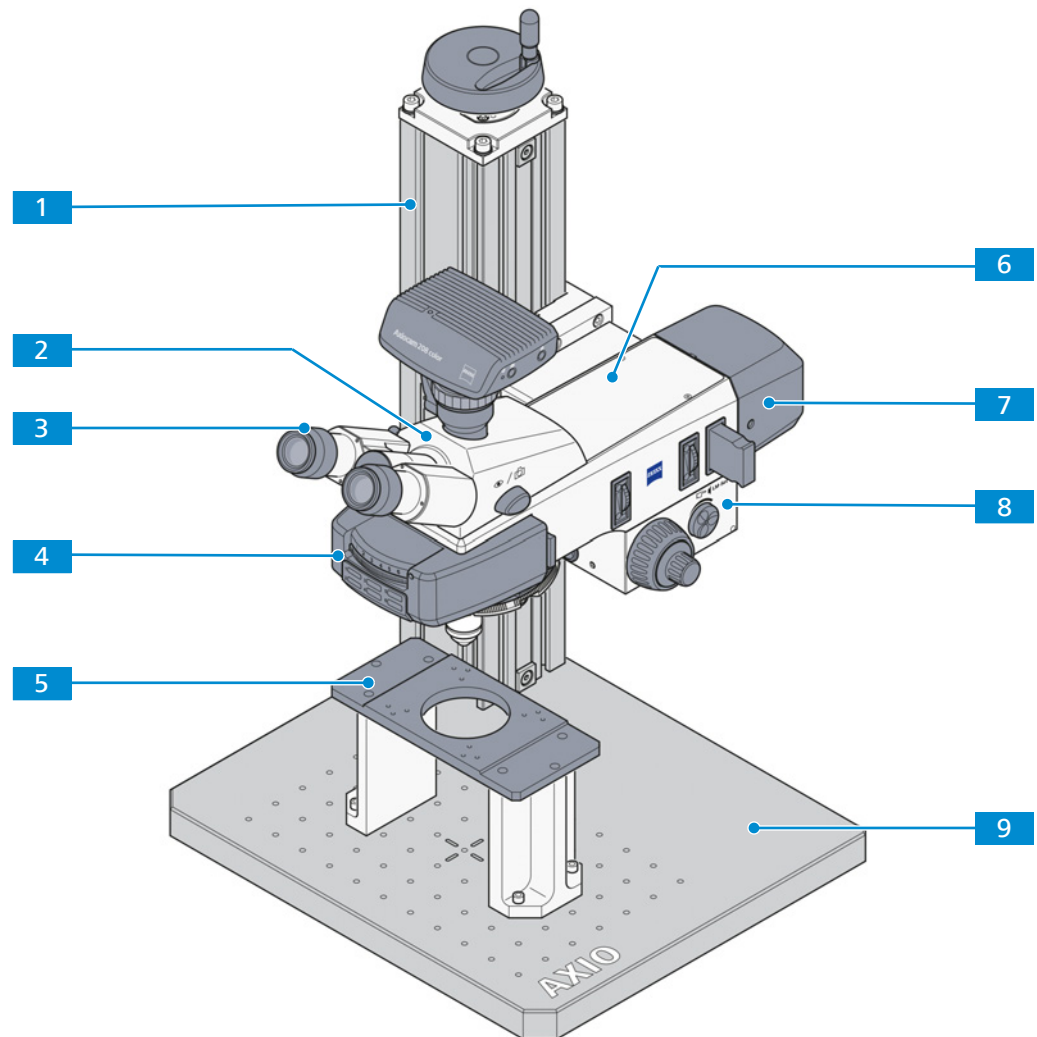

Fig. 10: Main components - Axioscope 5 Vario

- | | | | |
|----------|--|----------|---|
| 1 | Stand column Axioscope 5 Vario, 560 mm | 2 | Binocular tube [▶ 44] |
| 3 | Eyepieces [▶ 48] | 4 | Reflector turret [▶ 55] |
| 5 | Stage carrier, H = 140 mm | 6 | Upper part of the stand (including focusing gear box) |
| 7 | RL light source [▶ 131] | 8 | Focusing gear box for Axioscope 5 Vario, 15 mm focus lift |
| 9 | Base plate | | |

4.4.2 Controls and Functional Elements of Axioscope 5 Vario Stand

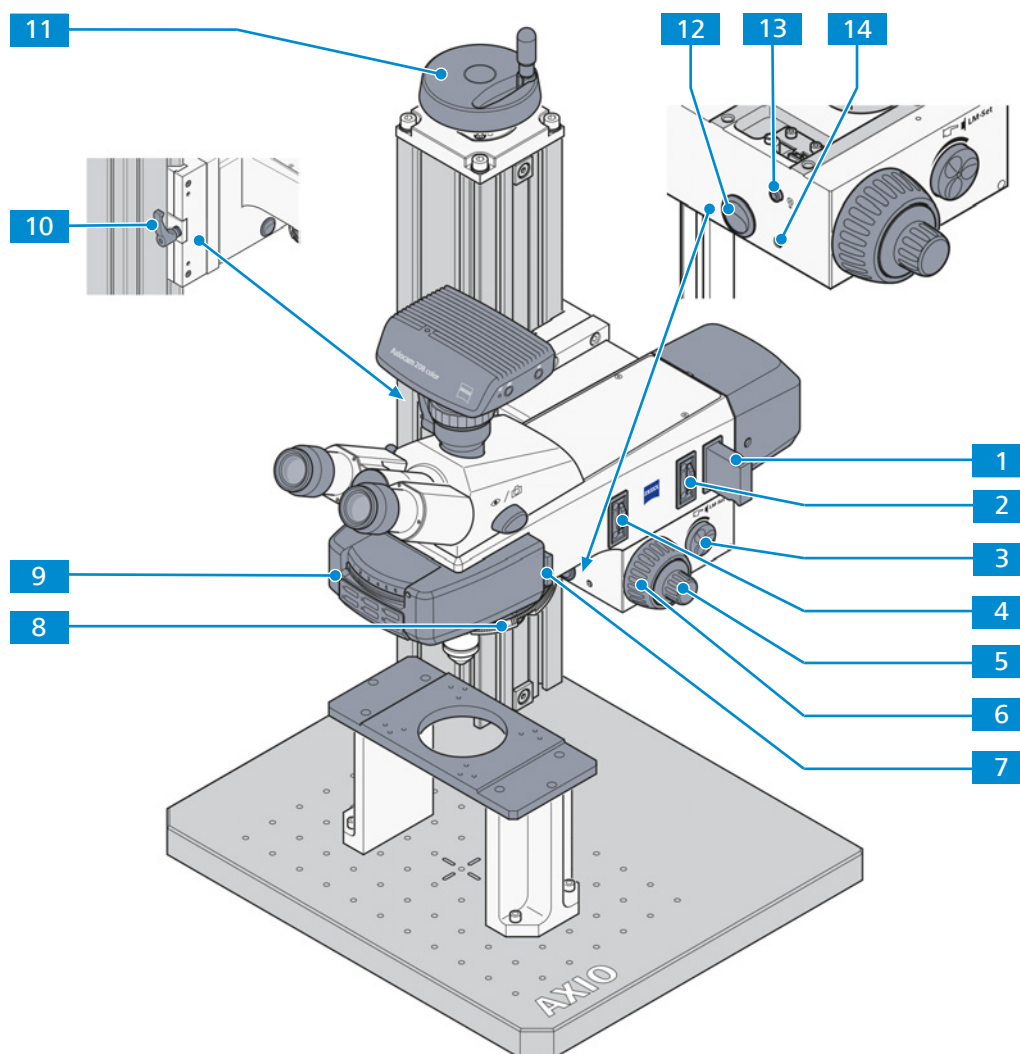

Fig. 11: Controls and functional elements - Axioscope 5 Vario

- | | | | |
|-----------|--|-----------|---|
| 1 | Filter slider for reflected light | 2 | Aperture diaphragm for reflected light |
| 3 | Intensity/LM knob for light intensity and Light Manager function (LM) and switching between fluorescence channels | 4 | Luminous-field diaphragm for reflected light |
| 5 | Focusing drive – fine adjustment (left and right) | 6 | Focusing drive – coarse adjustment (left and right) |
| 7 | Slot for polarizer slider A 60x30 mm | 8 | Nosepiece |
| 9 | Reflector turret (for replaceable reflector modules) | 10 | Release lever for vertical adjustment |
| 11 | Hand wheel for vertical adjustment | 12 | Permanent/ECO mode switch |
| 13 | Snap button | 14 | Indicator light for reflected light |

4.5 Axioscope 7 TL

4.5.1 Main Components of Axioscope 7 TL

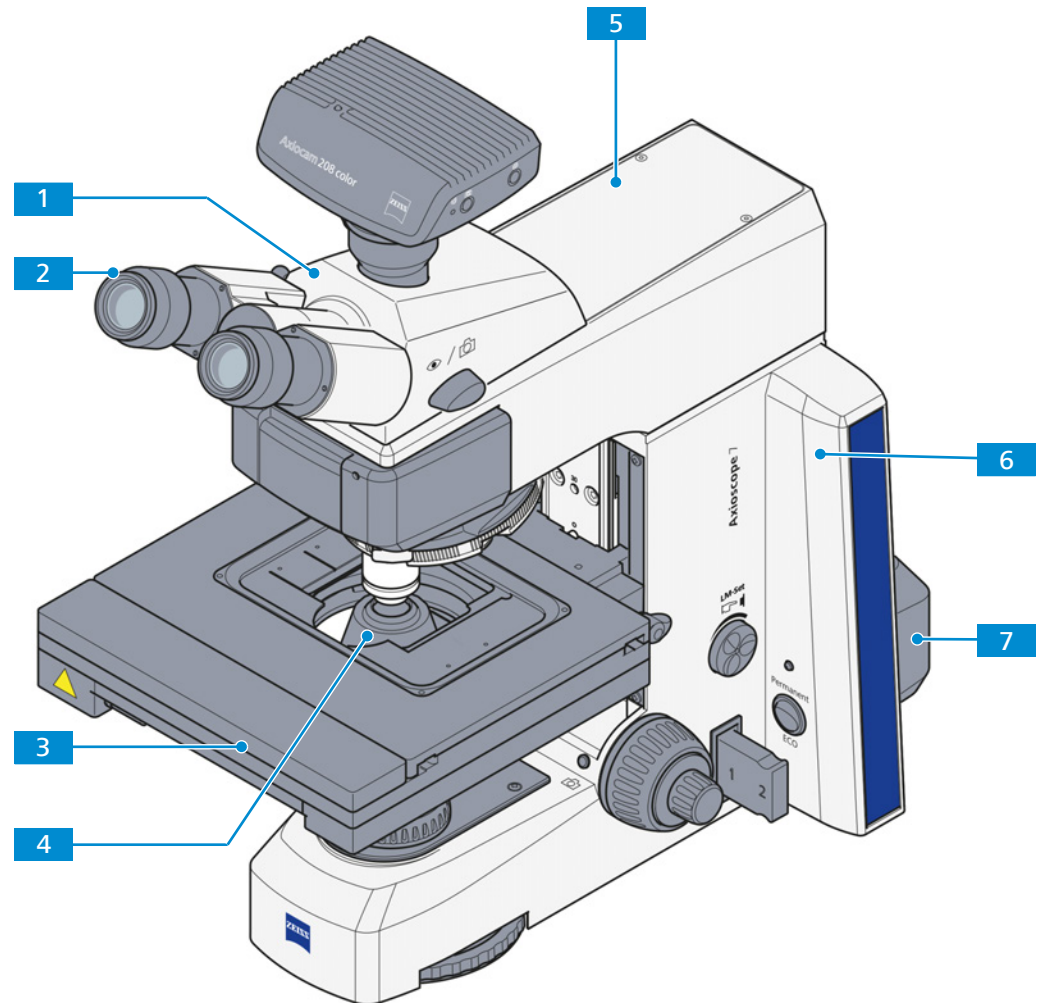

Fig. 12: Main components - Axioscope 7 TL

- | | | | |
|----------|---|----------|-------------------------|
| 1 | Binocular tube [▶ 44] | 2 | Eyepieces [▶ 48] |
| 3 | Mechanical stage [▶ 52] 80x60 mot. with sample holder | 4 | Condenser [▶ 50] |
| 5 | Upper part of the stand | 6 | Lower part of the stand |
| 7 | TL light source [▶ 131] | | |

4.5.2 Controls and Functional Elements of Axioscope 7 TL

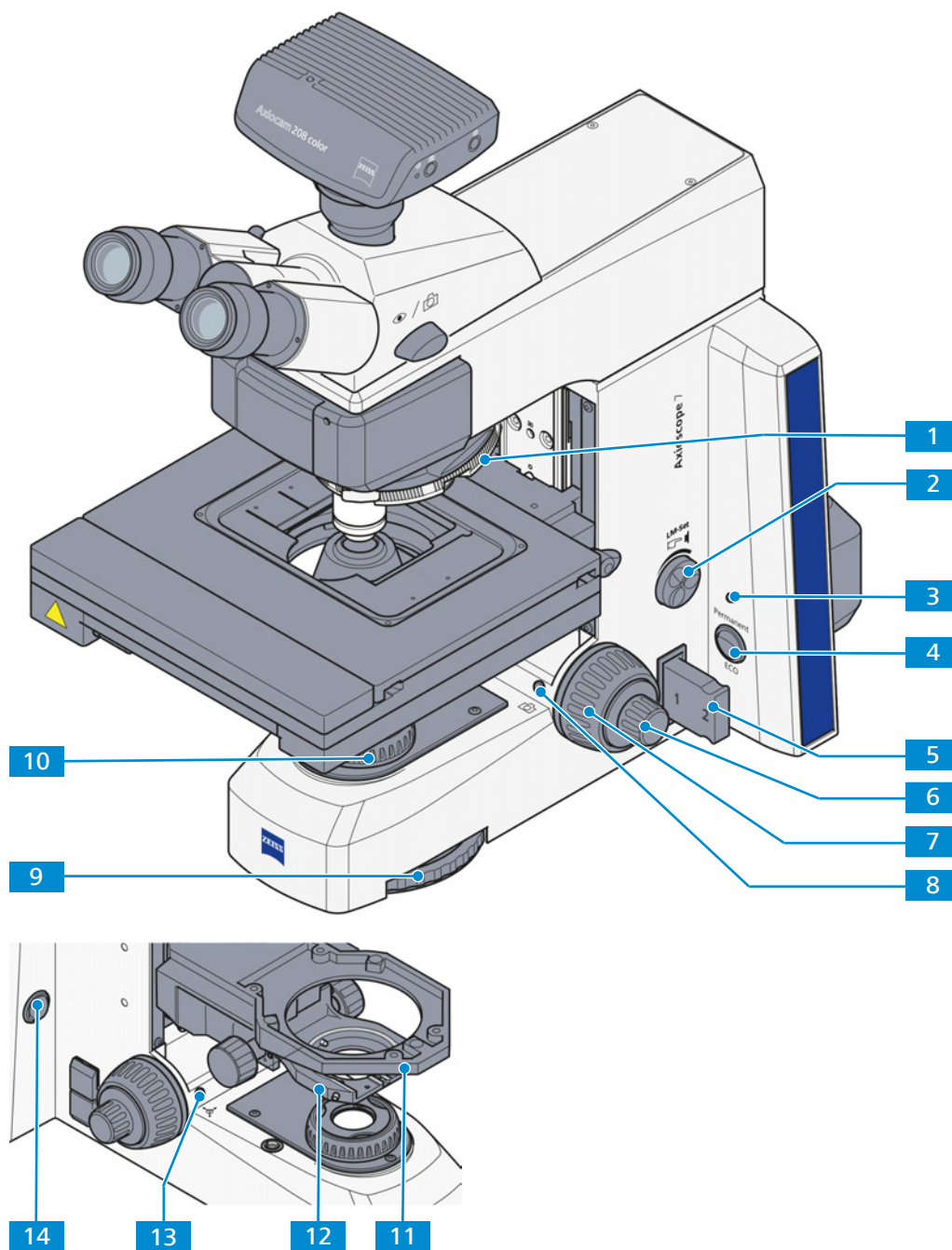

Fig. 13: Controls and functional elements - Axioscope 7 TL

- | | |
|--|---|
| 1 Nosepiece | 2 Intensity/LM knob for light intensity and Light Manager function (LM) and switching between fluorescence channels |
| 3 Indicator light for transmitted light | 4 Permanent/ECO mode switch |
| 5 Filter slider for transmitted light | 6 Focusing drive – fine adjustment (left and right) |
| 7 Focusing drive – coarse adjustment (left and right) | 8 Snap button (on the right side) |

- | | |
|---|--|
| 9 6-position filter wheel (operable from left and right) | 10 Luminous-field diaphragm for transmitted light |
| 11 Stage carrier | 12 Condenser carrier |
| 13 Stage control button (on the left side) | 14 Power switch On/Off |

4.6 Axioscope 7 TL/FL

4.6.1 Main Components of Axioscope 7 TL/FL

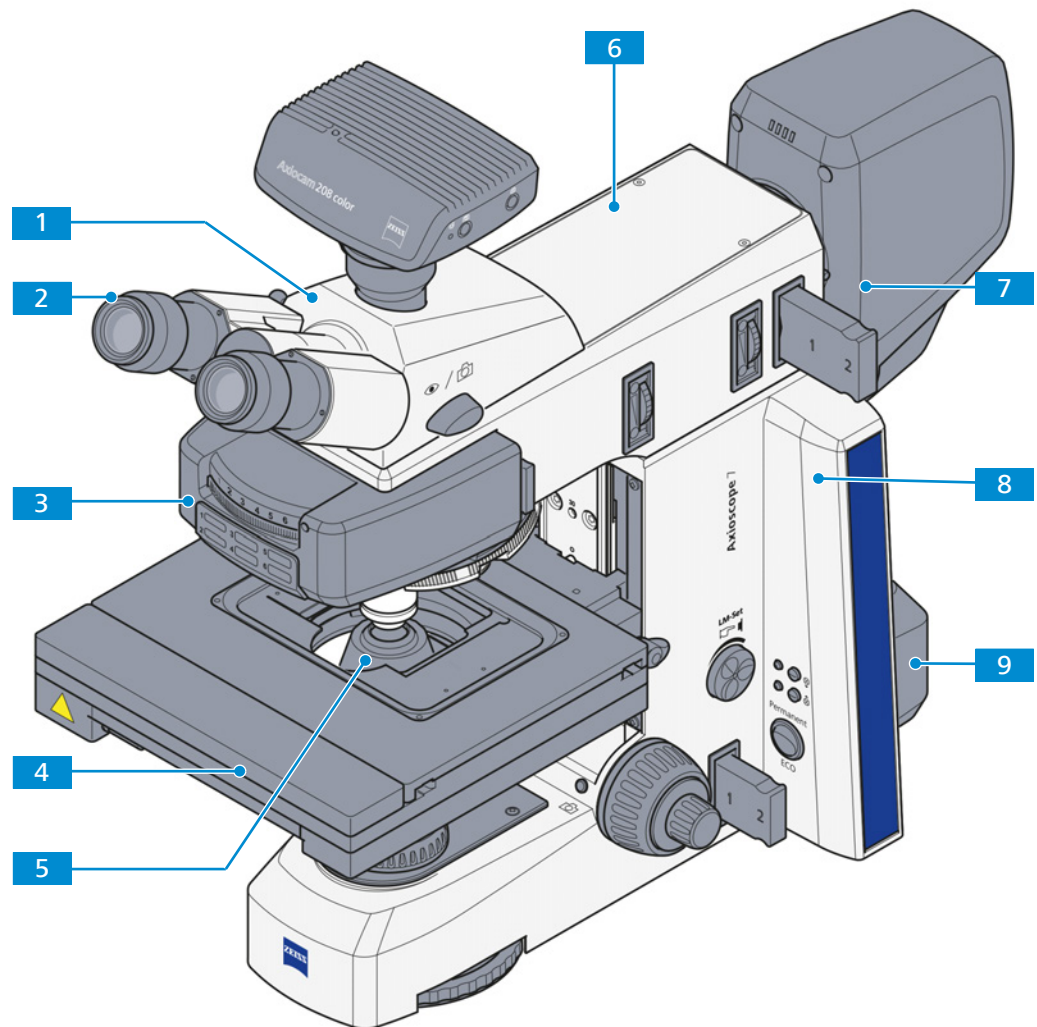

Fig. 14: Main components - Axioscope 7 TL/FL

- | | |
|--|---|
| 1 Binocular tube [▶ 44] | 2 Eyepieces [▶ 48] |
| 3 Mechanical stage [▶ 52] 80x60 mot. with sample holder | 4 Condenser [▶ 50] |
| 5 Upper part of the stand | 6 Lower part of the stand |
| 7 TL light source [▶ 131] | 8 Reflector turret |
| 9 RL light source for fluorescence | |

4.6.2 Controls and Functional Elements of Axioscope 7 TL/FL

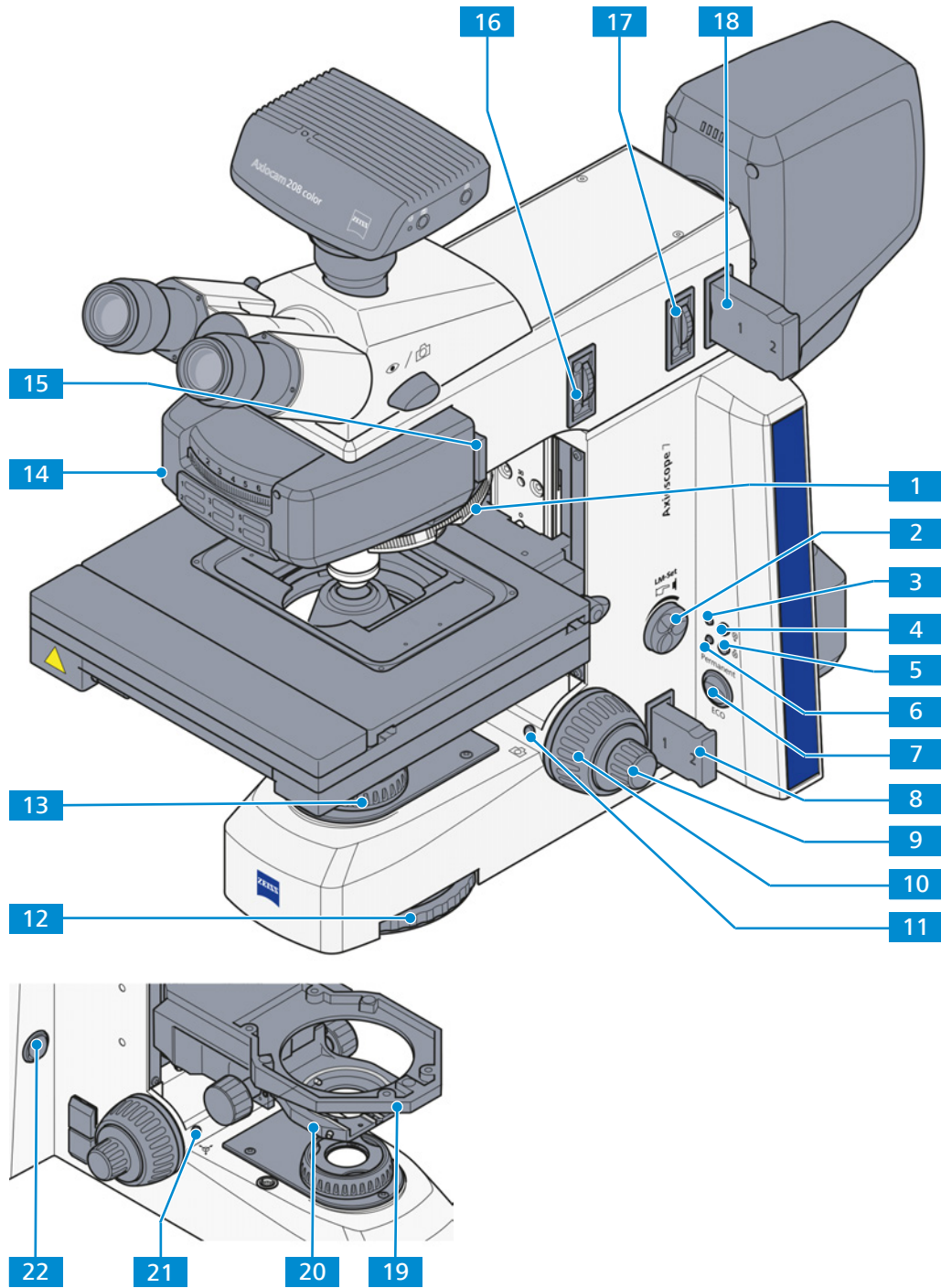

Fig. 15: Controls and functional elements - Axioscope 7 TL/FL

- | | |
|---|--|
| <ul style="list-style-type: none"> 1 Nosepiece 3 Indicator light for fluorescence 5 Transmitted light (TL) button 7 Permanent/ECO mode switch 9 Focusing drive – fine adjustment (left and right) | <ul style="list-style-type: none"> 2 Intensity/LM knob for light intensity and Light Manager function (LM) and switching between fluorescence channels 4 Fluorescence (FL) button 6 Indicator light for transmitted light 8 Filter slider for transmitted light 10 Focusing drive – coarse adjustment (left and right) |
|---|--|

- | | |
|--|--|
| 11 Snap button (on the right side) | 12 6-position filter wheel (operable from left and right) |
| 13 Luminous-field diaphragm for transmitted light | 14 Reflector turret (for replaceable reflector modules) |
| 15 Slot for polarizer slider A 60x30 mm | 16 Luminous-field diaphragm for reflected light |
| 17 Aperture diaphragm for fluorescence | 18 Filter slider for fluorescence |
| 19 Stage carrier | 20 Condenser carrier |
| 21 Stage control button (on the left side) | 22 Power switch On/Off |

4.7 Axioscope 7 RL

4.7.1 Main Components of Axioscope 7 RL

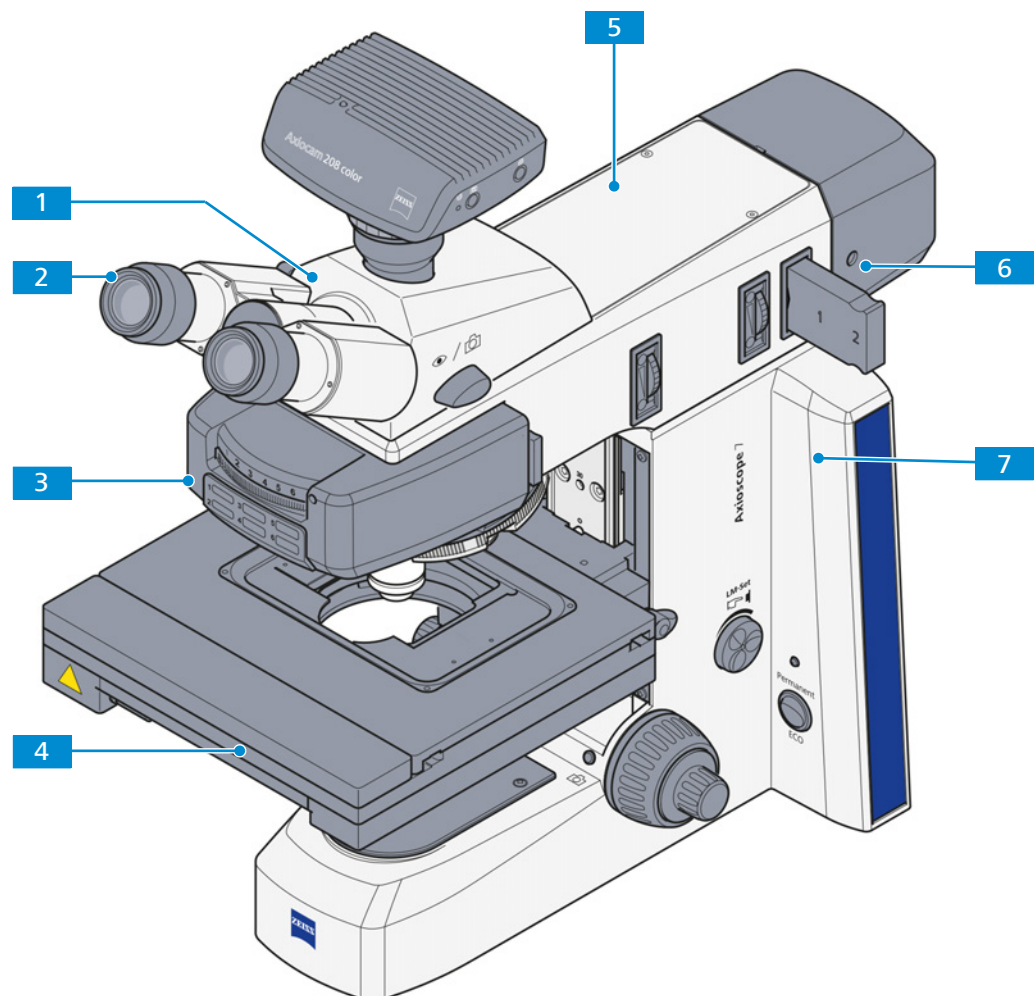

Fig. 16: Main components - Axioscope 7 RL

- | | |
|--|--|
| 1 Binocular tube [▶ 44] | 2 Eyepieces [▶ 48] |
| 3 Reflector turret | 4 Mechanical stage [▶ 52] 80x60 mot. with sample holder |
| 5 Upper part of the stand | 6 RL light source [▶ 131] |
| 7 Lower part of the stand | |

4.7.2 Controls and Functional Elements of Axioscope 7 RL

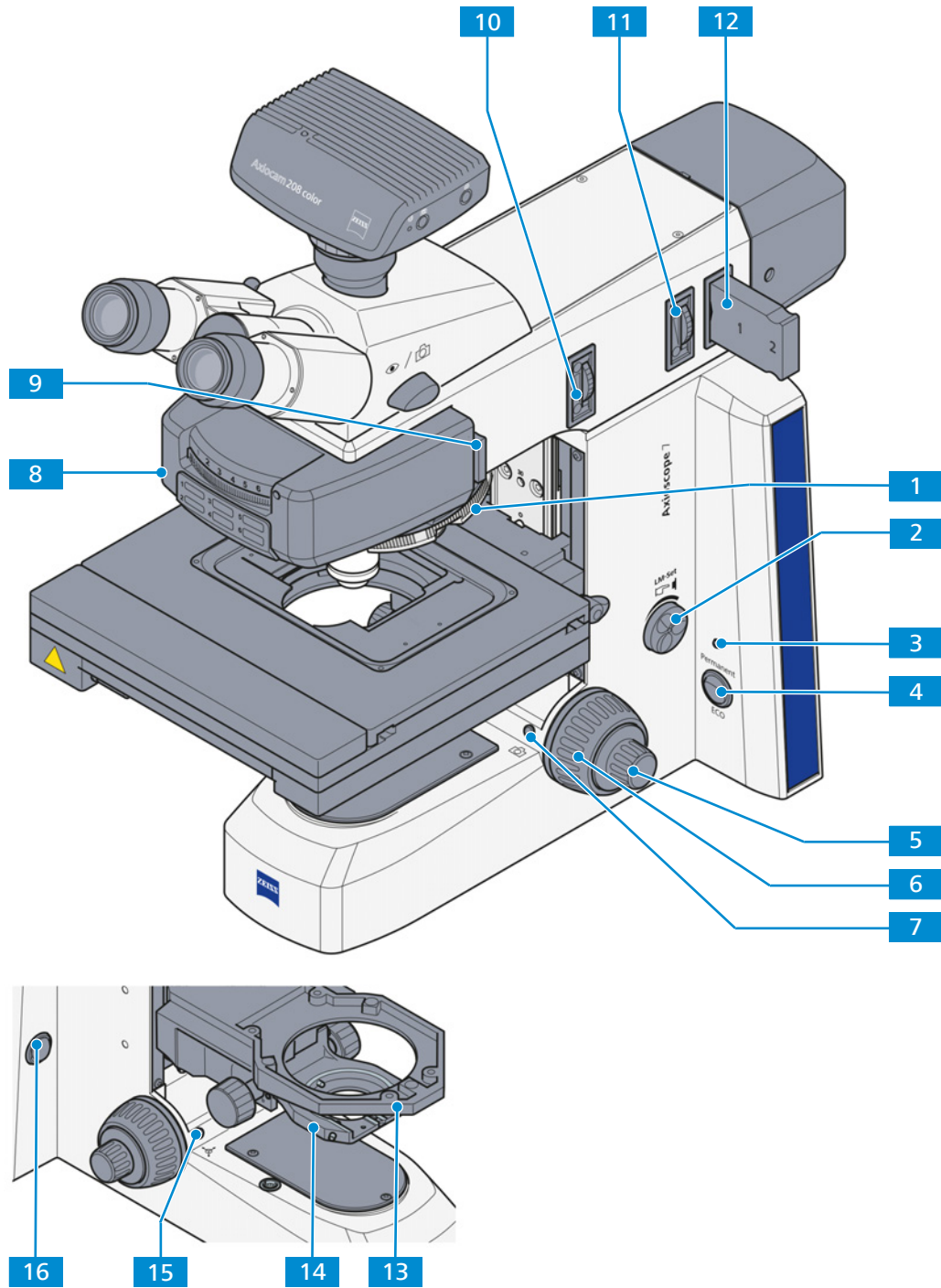

Fig. 17: Controls and functional elements - Axioscope 7 RL

- 1** Nosepiece

3 Indicator light for reflected light

5 Focusing drive – fine adjustment (left and right)

7 **Snap** button (on the right side)
- 2** **Intensity/LM** knob for light intensity and Light Manager function (LM) and switching between fluorescence channels

4 **Permanent/ECO** mode switch

6 Focusing drive – coarse adjustment (left and right)

8 Reflector turret (for replaceable reflector modules)

- | | |
|--|--|
| 9 Slot for polarizer slider A 60x30 mm | 10 Luminous-field diaphragm for reflected light |
| 11 Aperture diaphragm for reflected light | 12 Filter slider for reflected light |
| 13 Stage carrier | 14 Condenser carrier |
| 15 Stage control button (on the left side) | 16 Power switch On/Off |

4.8 Axioscope 7 TL/RL MAT

4.8.1 Main Components of Axioscope 7 TL/RL MAT

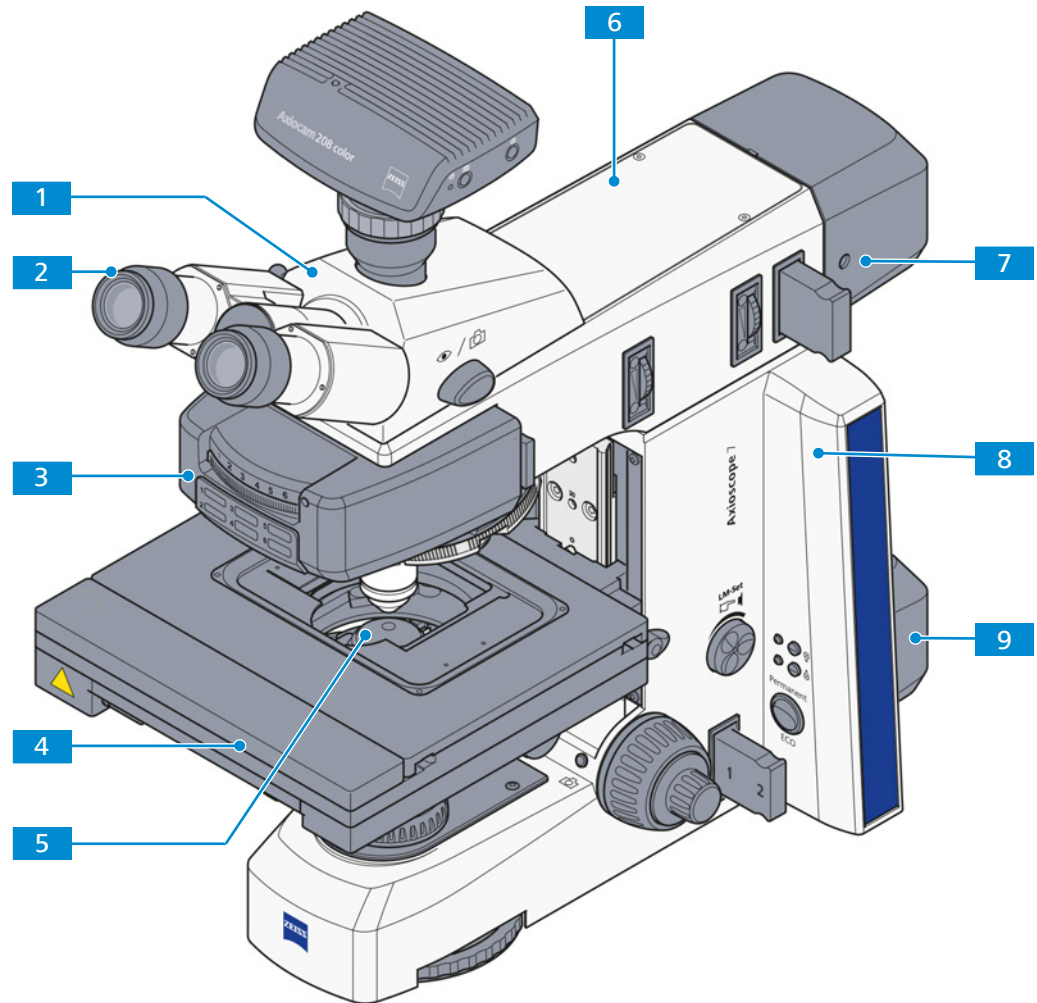

Fig. 18: Main components - Axioscope 7 TL/RL MAT

- | | |
|----------------------------------|--|
| 1 Binocular tube [▶ 44] | 2 Eyepieces [▶ 48] |
| 3 Reflector turret [▶ 55] | 4 Mechanical stage [▶ 52] 80x60 mot. with sample holder |
| 5 Condenser [▶ 50] | 6 Upper part of the stand |
| 7 RL light source [▶ 131] | 8 Lower part of the stand |
| 9 TL light source [▶ 131] | |

4.8.2 Controls and Functional Elements of Axioscope 7 TL/RL MAT Stand

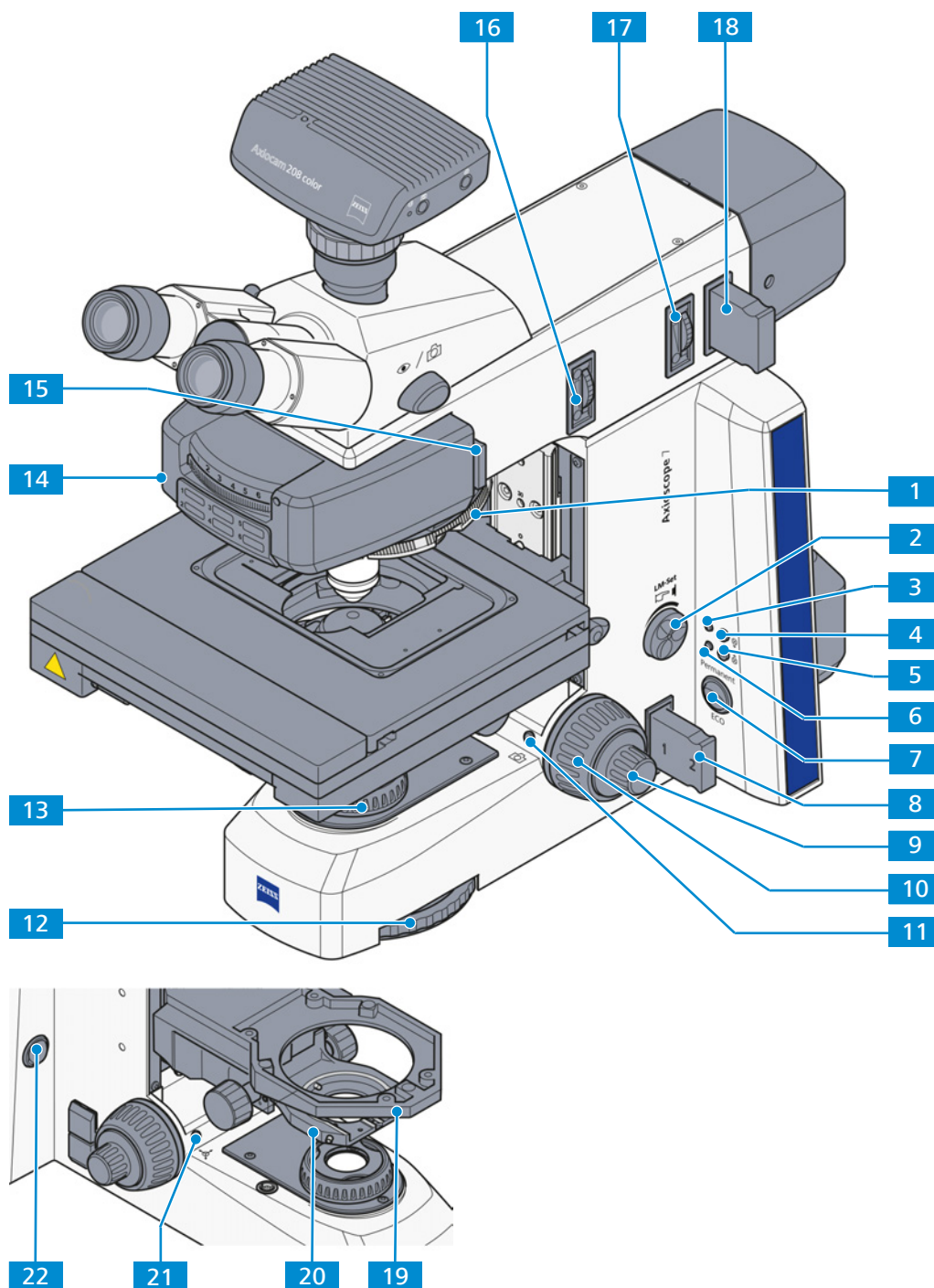

Fig. 19: Controls and functional elements - Axioscope 7 TL/RL MAT

- | | |
|--|---|
| 1 Nosepiece | 2 Intensity/LM knob for light intensity and Light Manager function (LM) and switching between fluorescence channels |
| 3 Indicator light for reflected light | 4 Reflected light (RL) button |
| 5 Transmitted light (TL) button | 6 Indicator light for transmitted light |
| 7 Permanent/ECO mode switch | 8 Filter slider for transmitted light |
| 9 Focusing drive – fine adjustment (left and right) | 10 Focusing drive – coarse adjustment (left and right) |

11 Snap button (on the right side)	12 6-position filter wheel (operable from left and right)
13 Luminous-field diaphragm for transmitted light	14 Reflector turret (for replaceable reflector modules)
15 Slot for polarizer slider A 60x30 mm	16 Luminous-field diaphragm for reflected light
17 Aperture diaphragm for reflected light	18 Filter slider for reflected light
19 Stage carrier	20 Condenser carrier
21 Stage control button (on the left side)	22 Power switch On/Off

4.9 Controls and Functional Elements on Components

4.9.1 Functions of Stand Keys and Display Elements

Key	Availability	Action	Functionality/Description
Power switch On/Off	Axio-scope 5/7/ Vario	I = on; O = off	Switches the microscope on/off.
Perma- nent/ECO mode switch	Axio-scope 5/7/ Vario	Toggle	Switches between Permanent (continuous) mode and ECO mode of the microscope illumination. <ul style="list-style-type: none"> Permanent mode active: illumination is continuously switched on. ECO mode active: illumination switches off after 15 minutes without action. Do not use ECO mode for experiments involving time-lapse or video recording.
RL button, TL button	Axio-scope 7 Optional Axio-scope 5	press < 1 s	Switches RL/TL illumination alternately on/off. The respective indicator light lights up GREEN continuously as long as the illumination source is activated. Second press to the RL/TL button to turn off/on the illumination (the indicator light not affected).
Intensity/ LM knob	Axio-scope 5/7/ Vario	Turn	Controls the light intensity of the active light source.
		press < 1 s	Repeated short pressing switches a single LED or all LEDs of the fluorescence light source together on or off.
		press > 1.5 s	Light Manager function: Saves the set light intensity. During this action, the indicator light blinks twice in GREEN and the image background appears BLACK for 300 ms (this does not apply to halogen illumination).

Key	Availability	Action	Functionality/Description
		press for 20 s	<p>Activates the factory default settings (enables Light Manager (LM), sets light intensity to the initial value, enables parfocality function, clears all saved parfocal positions).</p> <p>When the knob is pressed, the indicator light starts blinking* in RED after 3 s until 20 s is reached. After 20 s, the indicator light blinks in GREEN. Then release the knob. The indicator light turns to GREEN permanently if the system reset is done.</p> <p>After factory default reset, re-power the system.</p>
Left Snap button (only if Axio-cam 203 or 212 is attached)	Axio-scope 5	press < 1 s	Snaps an image; when the snap is completed, the attached monitor appears in BLACK for 50 ms.
		press > 1.5 s	Starts video recording; another short press is required to stop recording. After recording is finished, the attached monitor appears in BLACK for 300 ms.
Right Snap button (only if Axio-cam 203 or 212 is attached)	Axio-scope 5/7/ Vario	press < 1 s	Snaps an image; when the snap is completed, the attached monitor appears in BLACK for 50 ms.
		press > 1.5 s	Starts video recording; another short press is required to stop recording. After recording is finished, the attached monitor appears in BLACK for 300 ms.
Snap button + Intensity/LM knob	Axio-scope 5/7/ Vario	press > 1.5 s simultaneously	<p>Disables/enables the Light Manager (LM) functionality:</p> <ul style="list-style-type: none"> Disabling: The indicator light blinks GREEN / ORANGE / GREEN in sequence. Enabling: The indicator light blinks GREEN / GREEN / GREEN in sequence. <p>By factory default, the Light Manager functionality is enabled.</p>
Left + Right Snap buttons	Axio-scope 5	press > 1.5 s simultaneously	Disables/enables the dazzle protection function:
Snap button + Stage control button	Axio-scope 7		<ul style="list-style-type: none"> Disabling: The indicator light blinks ORANGE twice. Enabling: The indicator light blinks GREEN twice. <p>By factory default, the dazzle protection function is enabled.</p>
Stage control button	Axio-scope 7	press < 1 s	<p>Switches between XY stage control and Z axis control via focus drives:</p> <p>If Z axis control is active:</p> <ul style="list-style-type: none"> the indicator light lights in GREEN permanently the left and right fine focusing drive control slow Z-movement (focusing)

Key	Availability	Action	Functionality/Description
			<ul style="list-style-type: none"> the left and right coarse focusing drive control fast Z-movement (focusing) <p>If XY stage control is active:</p> <ul style="list-style-type: none"> the indicator light blinks GREEN the left focus drives (fine or coarse) control Y movement (slow or fast) of the stage the right focus drives (fine or coarse) control X movement of (slow or fast) the stage
		press for 8 s	<p>Starts and stops the parfocality calibration:</p> <ul style="list-style-type: none"> Starting: indicator light turns RED. Stopping: indicator light turns GREEN.
		press < 1 s	<p>During parfocality calibration: records the parfocal position.</p> <ul style="list-style-type: none"> If using LED illumination: The LED shuts off for 300 ms for indication. If using halogen illumination: no indication the indicator light blinks twice in GREEN
Snap button+ Stage control button	Axio-scope 7	press < 1 s simultaneously	Load/unload alternately.
Stage control button + Intensity/LM knob	Axio-scope 7	press > 1.5 s simultaneously	<p>Disables/enables the parfocality function:</p> <ul style="list-style-type: none"> Disabling: The indicator light blinks ORANGE twice. Enabling: The indicator light blinks GREEN twice. <p>By factory default, the parfocality function is enabled.</p>

* Blinking: the indicator light alternately goes on/off at 500 ms intervals

4.9.2 Binocular Tube

Various tubes with different inclination angles enable suitable eye levels to be selected for observation.

4.9.2.1 Binocular Photo Tube 30°/23 (50:50)

Purpose Binocular photo tubes are used to observe the microscopic image by means of the eyepieces and/or acquire images with a camera. Using the camera port, the microscopic image can be sent to a connected camera.

Position The binocular photo tube is mounted on the top of the stand.

Function The pupil distance and the viewing height can be adjusted with the aid of the binocular section.

The following features and controls are available:

- reversed image
- camera port with fixed light graduation (50:50)
- viewing angle 30°
- field of view 23 mm

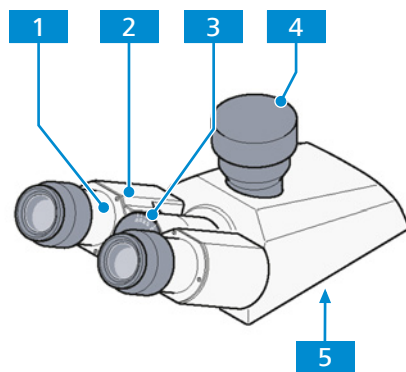

Fig. 20: Binocular Photo Tube 30°/23 (50:50)

- | | |
|------------------------------|--------------------------------|
| 1 Eyepiece socket | 2 Binocular section |
| 3 Angle scale | 4 Camera port (covered) |
| 5 Dovetail ring mount | |

4.9.2.2 Binocular Photo Tube 30°/23 (100:0/0:100)

Purpose Binocular photo tubes are used to observe the microscopic image by means of the eyepieces and/or acquire images with a camera. Using the camera port, the microscopic image can be sent to a connected camera.

Position The binocular photo tube is mounted on the top of the stand.

Function The pupil distance and the viewing height can be adjusted with the aid of the binocular section.

The following features and controls are available:

- reversed image
- camera port with toggle graduation (100:0/0:100)
- viewing angle 30°
- eyepiece shutter
- field of view 23 mm

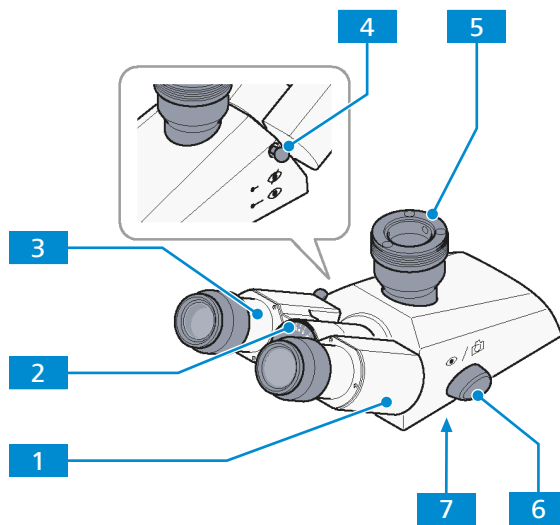

Fig. 21: Binocular Photo Tube 30°/23 (100:0/0:100)

- | | |
|------------------------------|--|
| 1 Binocular section | 2 Angle scale |
| 3 Eyepiece socket | 4 Eyepiece shutter <ul style="list-style-type: none"> ▪ Push-pull rod pushed in: eyepiece shutter closed ▪ Push-pull rod pulled out: eyepiece shutter opened |
| 5 Camera port | 6 Shift knob for selecting the graduation <ul style="list-style-type: none"> ▪ Shift knob to front (eye symbol): 100% light to eyepieces ▪ Shift knob to the rear (camera symbol): 100% light to camera |
| 7 Dovetail ring mount | |

4.9.2.3 Binocular Photo Tube 20°/23 (100:0/0:100)

Purpose Binocular photo tubes are used to observe the microscopic image by means of the eyepieces and/or acquire images with a camera. Using the camera port, the microscopic image can be sent to a connected camera.

Position The binocular photo tube is mounted on the top of the stand.

Function The pupil distance and the viewing height can be adjusted with the aid of the binocular section.

The following features and controls are available:

- upright image
- camera port with toggle graduation (100:0/0:100)
- viewing angle 20°
- field of view 23 mm

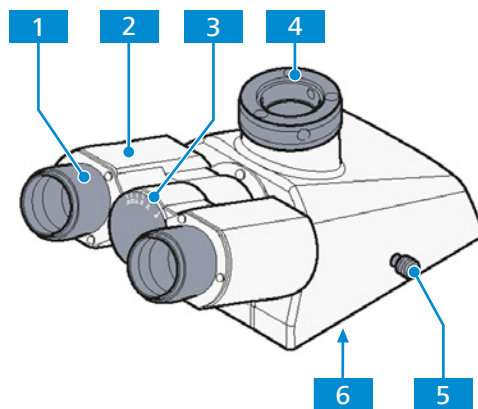

Fig. 22: Binocular Photo Tube 20°/23 (100:0/0:100)

- | | |
|--|------------------------------|
| 1 Eyepiece socket | 2 Binocular section |
| 3 Angle scale | 4 Camera port |
| 5 Slider for selecting the graduation | 6 Dovetail ring mount |
- Slider pushed in: 100% light to eyepieces
 - Slider pulled out: 100% light to camera. 100% light to camera

4.9.2.4 Binocular Ergo Photo Tube -2° to 28°/23 (50:50), Reversed Image

Purpose Binocular photo tubes provide users with the convenience of accessing the sample images using eyepieces as well as monitors through camera at the same time. Users can change the angle from -2° to 28° to meet the ergonomic requirement of specific operators.

Position The binocular photo tubes are mounted on the top of the stand.

Function The pupil distance and viewing height can be adjusted by bending the binocular device up or down.

The following features and controls are available:

- Reverse image
- Camera port with splitting ratio 50:50
- Viewing angle -2° to 28°
- Field of view 23 mm

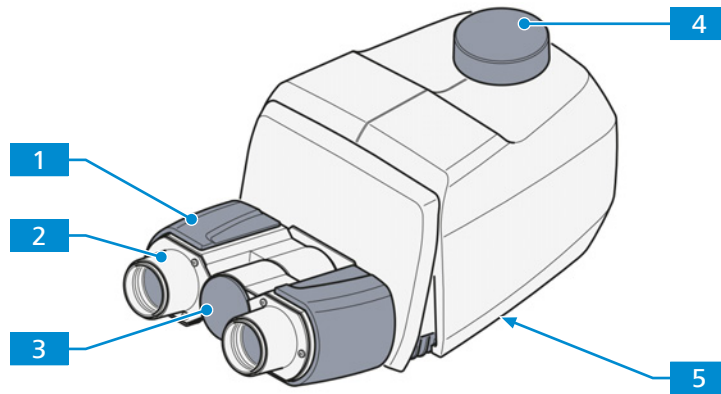

Fig. 23: Binocular ergo photo tube -2° to 28°/23 (50:50), reversed image

- | | | | |
|----------|---------------------|----------|-----------------------|
| 1 | Binocular section | 2 | Eyepiece socket |
| 3 | Angle scale | 4 | Camera port (covered) |
| 5 | Dovetail ring mount | | |

4.9.2.5 Binocular Ergo Photo Tube -2° to 28°/25 (50:50), Reversed Image

Purpose Binocular photo tubes provide users with the convenience of accessing the sample images using eyepieces as well as monitors through camera at the same time. Users can change the angle from -2° to 28° to meet the ergonomic requirement of specific operators.

Position The binocular photo tubes are mounted on the top of the stand.

Function The pupil distance and viewing height can be adjusted by bending the binocular device up or down.

The following features and controls are available:

- Reverse image
- Camera port with splitting ratio 50:50
- Viewing angle -2° to 28°
- Field of view 25 mm

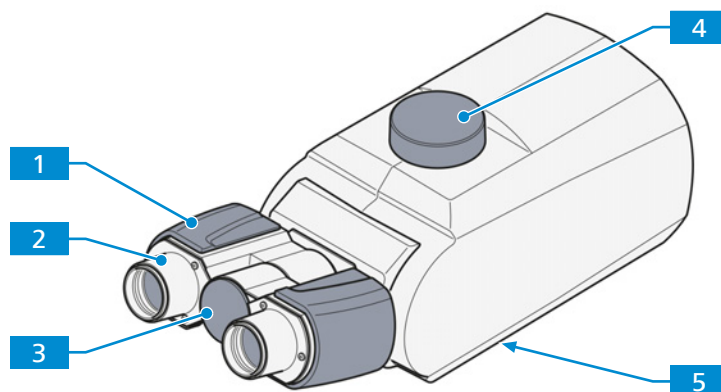

Fig. 24: Binocular ergo photo tube -2° to 28°/25 (50:50), reversed image

- | | | | |
|----------|---------------------|----------|-----------------------|
| 1 | Binocular section | 2 | Eyepiece socket |
| 3 | Angle scale | 4 | Camera port (covered) |
| 5 | Dovetail ring mount | | |

4.9.3 Eyepieces

4.9.3.1 Eyepieces

Purpose The eyepieces serve to observe the microscopic image.

Position The eyepieces are inserted into the eyepiece sockets of the binocular tube.

Function Both eyepieces are suitable for spectacle wearers. Additionally, they contain a focusing ring for compensation of defective vision. The provided diopter scale helps to find the correct setting. When using the microscope for fluorescence applications, the special eyecups with light protection can be used. However, they cannot be folded over and are not suitable for spectacle wearers.

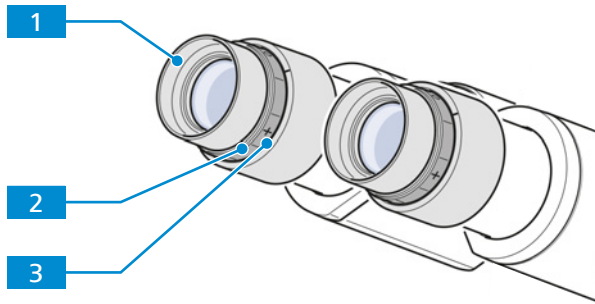

Fig. 25: Eyepiece

- 1** Eyecup (e.g. Foldover rubber eyecup)
- 2** Focusing ring
- 3** Diopter scale

4.9.3.2 Eyepieces with Eyepiece Reticles

Purpose The eyepieces with eyepiece reticles serve to observe the microscopic image in special microscopy procedures.

Position The eyepieces with reticles are inserted into the tube. This should only be carried out by a ZEISS service representative. However, it is possible for users to insert the reticles themselves when adhering to the following instructions.

The eyepiece reticles must be inserted under dust-free conditions.

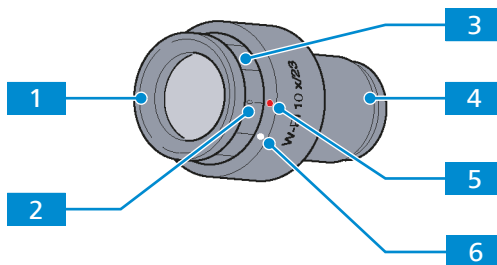

Fig. 26: Eyepiece with installed eyepiece reticle

- 1** Eyecup, changeable
- 2** Diopter scale with zero point to facilitate finding the correct setting
- 3** Focusing ring for compensation of defective vision
- 4** Mounting stop with inserted eyepiece reticle
- 5** Red dot, corresponds to the zero diopter setting when a reticle is inserted
- 6** White dot, corresponds to the zero diopter setting when no reticle is inserted

4.9.3.3 Focusable Pol Eyepiece

The focusable eyepiece can be set into the binocular photo tube with upright image.

The focusable Pol eyepiece contains a reticle firmly glued into it (cannot be changed), which is of defined orientation. When changing the interpupillary distance on the binocular photo tube, the two eyepiece tubes follow this rotary motion synchronously, so that the position of the orientation grooves in the eyepiece tubes remains unchanged.

The PL 10x/23 GW foc. Pol eyepiece can be combined with a PL 10x/23 GW foc. eyepiece.

4.9.4 Nosepiece with Objectives

Purpose The nosepiece is used to hold the objectives and to swivel the desired objective into the beam path.

Position The nosepiece is mounted on the upper part of the stand.

The following features and controls are available:

- nosepiece with M27 mounting thread for six objectives
- one objective position is fixed and four positions can be centered with the aid of two screws each
- equipped with three, six or no DIC positions depending on the configuration
- equipped with slot for 6x20mm sliders (compensators, analyzers, quarter plates or fluorescence protection shield)

Info

The nosepiece with 5-positions HF/DF/Pol and 1-position HF/DF/DIC is equipped with five centerable objective mounts (without DIC slots) as well as one objective mount with DIC slot (non-centerable). Accordingly, all objectives can be centered relative to the rotary stage.

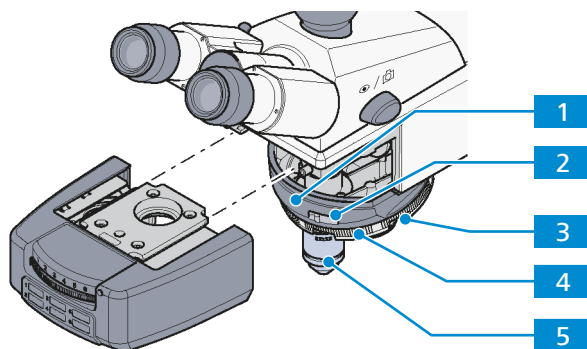

Fig. 27: Nosepiece with objectives

- | | |
|--------------------|---|
| 1 Nosepiece | 2 Slot 6x20mm |
| 3 DIC slot | 4 Knurled ring for swivelling the nose-piece |
| 5 Objective | |

4.9.5 Condenser Carrier

Purpose The condenser carrier is used to hold the condenser.

Position The condenser carrier is mounted onto the stage carrier.

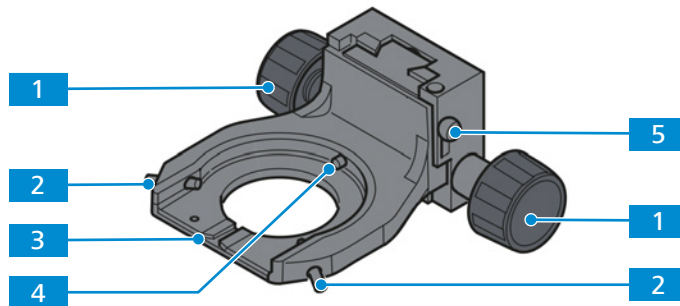

Fig. 28: Condenser carrier

- | | |
|--|--|
| 1 Knurled knob for vertical adjustment (left/right) | 2 Centering hex screw (left/right), optional: knurled screw |
| 3 Orientation groove | 4 Main spring |
| 5 Fastening screw for height stop | |

4.9.6 Condensers

4.9.6.1 Condenser 0.9/1.25 BF

Purpose Condensers are used to optimize the transmitted light illumination. The condenser 0.9/1.25 BF is usable for brightfield applications.

Position The condenser is mounted on the condenser carrier of the stand.

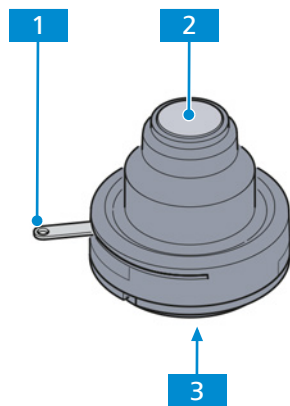

Fig. 29: Condenser 0.9/1.25 BF

- | | |
|---|---------------------|
| 1 Lever for setting the aperture diaphragm | 2 Front lens |
| 3 Dovetail ring mount | |

4.9.6.2 Condenser 0.9/1.25 BF, DF, Ph1, Ph2, Ph3 with modulator disk

Purpose Condensers are used to optimize the transmitted light illumination. The condenser with modulator disk is usable for brightfield, darkfield and phase contrast applications.

Position The condenser is mounted on the condenser carrier of the stand.

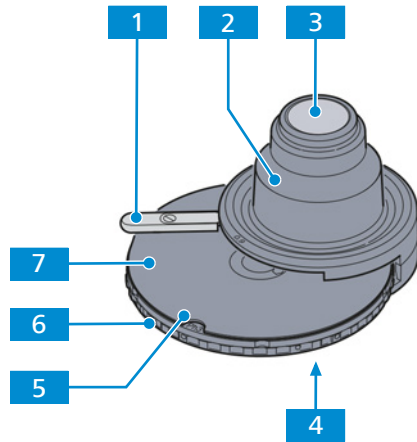

Fig. 30: Condenser 0.9/1.25 BF, DF, Ph1, Ph2, Ph3 with modulator disk

- | | | | |
|----------|---|----------|---|
| 1 | Lever for setting the aperture diaphragm | 2 | Front lens |
| 3 | Condenser 0.9/1.25 BF, optionally condenser 0.9/1.25 BF Pol | 4 | Dovetail ring mount |
| 5 | Display field of the adjusted modulator disk position | 6 | Knurled ring for adjusting the position of the modulator disk |
| 7 | Modulator disk with 5 positions for condenser modules | | |

4.9.6.3 Condenser 0.8 BF WD=5.8mm

Purpose Condensers are used to optimize the transmitted light illumination. The condenser 0.8 BF is usable for brightfield applications.

Position The condenser is mounted on the condenser carrier of the stand.

The following features and controls are available:

- NA of 0.8 in air and WD of 5.8 mm
- Suitable for brightfield observation with objectives 5x to 100x
- Compatible with low-power system for objectives 2.5x/4x

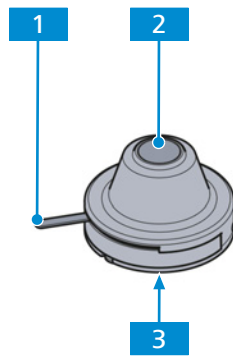

Fig. 31: Condenser 0.8 BF WD=5.8mm

1 Lever for setting the aperture diaphragm

2 Front lens

3 Dovetail ring mount

4.9.7 Stages

A stage is a platform at right angles to the optical axis of the microscope, which carries the sample and which is often fitted with mechanical movements (as in a mechanical stage) to allow easy positioning of the object in the x- and y-axis, and movement along, and rotation about the z-axis.

4.9.7.1 Rackless Mechanical Stage, 75x50 R

Purpose Mechanical stages are used for fixing and positioning the sample for examination.

Position The mechanical stages are mounted on the stage carrier of the stand.

Function The sample is fixed on the stage by means of the sample holder. For this purpose, the sample holder is equipped with a spring lever.

The sample is positioned in the beam path by means of the two coaxial drives in x and y direction. The adjustment range can be read off the respective vernier scale.

The following features and controls are available:

- rackless stage
- coaxial drives in X and Y adjustment on the right (R), optionally on the left (L)
- travel range 75x50mm
- with hardcoat anodized surface

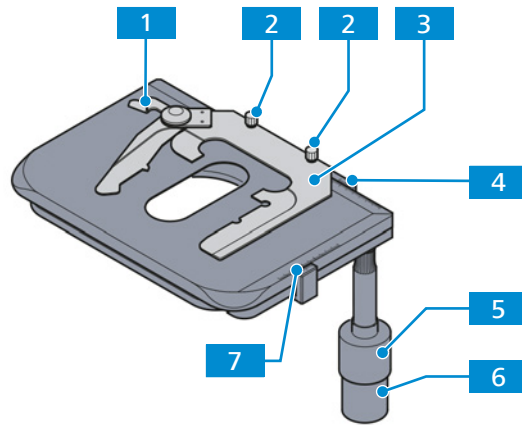

Fig. 32: Rackless mechanical stage, 75x50 R

- | | | | |
|----------|--|----------|--|
| 1 | Spring lever | 2 | Knurled screw (2x) for fixing the sample holder to the stage |
| 3 | sample holder for double slides 76x26 | 4 | Vernier scale for display of the adjustment range in X |
| 5 | Coaxial knurled knob for Y adjustment | 6 | Coaxial knurled knob for X adjustment |
| 7 | Vernier scale for display of the adjustment range in Y | | |

4.9.7.2 Mechanical Stage, 80x60, Motorized

Purpose Mechanical stages are used for fixing and positioning the sample for examination.

Position This motorized mechanical stage is mounted on the stage carrier of the Axioscope 7 stand only.

Function The sample is fixed on the stage by means of insert plates (160x116) or mounting frames (for two sample sliders 76x26) that are inserted into the stage supporting surface.

The sample is positioned in the beam path by means of the motorized adjustment drives in X and Y direction using the *stage control button* [▶ 41].

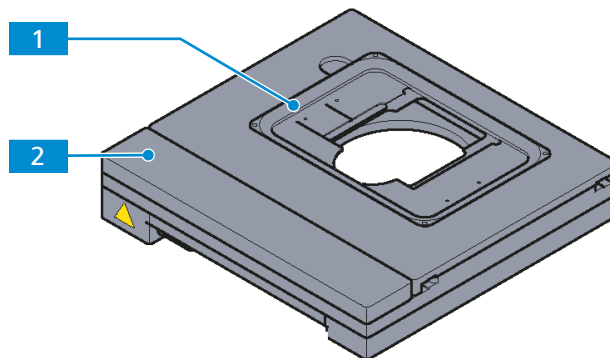

Fig. 33: Mechanical stage, 80x60, motorized

- | | | | |
|----------|---|----------|------------------|
| 1 | Supporting surface for insert plates or mounting frames | 2 | Mechanical stage |
|----------|---|----------|------------------|

4.9.7.3 Rotary Stage Pol 360° with Specimen Guide

Purpose Rotary stages are used for fixing and positioning the sample for examination in polarized light.

Position The rotary stages are mounted on the stage carrier of the stand.

Function The sample is fixed on the stage by means of the sample guide. For this purpose, the sample guide is equipped with a spring lever.

The sample is positioned in the beam path by means of the two knurled knobs of the sample guide. The adjustment range can be read off the respective vernier scale.

The following features and controls are available:

- optionally equipped with: attachable sample guide for use of standard slides 45x25 mm and 75x25 mm (3"x1")
- 360° rotation with lock
- click stop every 45°

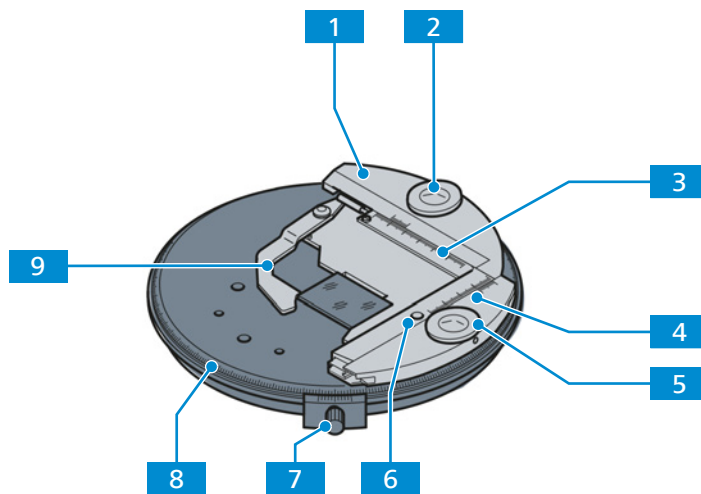

Fig. 34: Rotary Stage Pol 360° with Specimen Guide

- | | |
|---|---|
| 1 Specimen guide | 2 Knurled knob for adjustment in X direction |
| 3 Vernier scale for display of the adjustment range in X | 4 Vernier scale for display of the adjustment range in Y |
| 5 Knurled knob for adjustment in Y direction | 6 Mounting hole to get access to the clamping screw |
| 7 Knurled screw for locking the rotation, 360° rotation possible | 8 Angle scale |
| 9 Spring lever | |

4.9.8 Reflector Inserts

4.9.8.1 Reflector Turret with 4x or 6x Coded Positions

Purpose The reflector turret is used to hold the push-and-click (P&C) reflector modules and to swivel the desired reflector module into the beam path.

Position The reflector turret is mounted above the nosepiece.

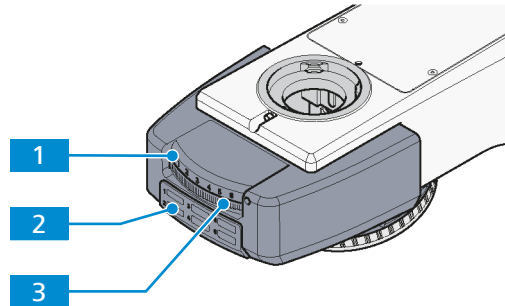

Fig. 35: Reflector turret

- | | |
|--|---|
| <p>1 Display indicates which reflector module is in the beam path</p> | <p>2 Field for the supplied stickers, the stickers can be labeled with the filter combination data of the reflector module and pasted on the corresponding field</p> |
| <p>3 Knurled ring to swivel the desired reflector module into the beam path</p> | |

4.9.8.2 Reflector Slider with Two Coded Positions

The reflector slider with two coded positions is equipped with two individually loadable reflector positions for P&C modules which can be slid into the beam path.

Purpose The reflector slider is used to hold two push-and-click (P&C) reflector modules and to slid the desired reflector module into the beam path.

Position The reflector turret is mounted on the upper part of the stand above the nosepiece.

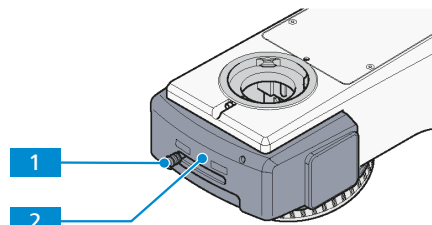

Fig. 36: Reflector slider

- | | |
|--|---|
| <p>1 Slider to slid the desired reflector module into the beam path</p> | <p>2 Field for the supplied stickers, the stickers can be labeled with the filter combination data of the reflector module and pasted on the corresponding field</p> |
|--|---|

4.10 Light Manager Function

The Light Manager (LM) function allows users to save the favorable light intensity of specific objective and turret combinations. Afterwards, when switching between different objectives or reflector turrets, the saved light intensity will be automatically applied. Restarting the microscope will not vanish the saved value.

This value can be overwritten among different users with unlimited times.

Dazzle protection (ON by default) is used to switch off the light when switching objectives or reflector turrets such that the field of view is dark after first objective or turret leaves the position and before the second arrives in. Users can manually turn it off, so the field of view remains the brightness of the first objective or turret until the second one arrives in the position.

4.11 Microscopy and Contrast Methods

4.11.1 Transmitted Light Brightfield Contrast Using the KÖHLER Method

Transmitted light brightfield contrast is the most common of all optical contrast methods, since it can be used to quickly and easily examine high-contrast or stained samples (e.g. blood smears).

In order to obtain an image as close as possible to the object, not only the so-called direct beam bundles but also the indirect ones, i.e. the beam bundles diffracted and scattered at the preparation details, are of essential importance. According to ABBE, the larger the indirect beam components are, the more true to the object the microscopic image is.

The best performance of the microscope, and especially its objective, is achieved when the condenser, field stop and aperture stop are adjusted in accordance with the KÖHLER illumination principles.

4.11.2 Transmitted Light Darkfield Contrast Using the KÖHLER Method

In the transmitted light darkfield contrast method you basically illuminate the sample with an illumination aperture which is higher than the one of the objective you are using.

In darkfield microscopy, only the diffracted and scattered light portions which are important for the imaging procedure get into the objective, whereas the indirect unaffected light beams are directed past the objective. Thus a resolution of fine structures can be achieved which is below the resolution capacity of a light microscope. The fine structures now appear bright and incandescent on a dark background.

Darkfield samples need to be kept impeccably clean, more so than samples for any other method. A fingerprint, dust or any dirt particle can have a negative effect, as they brighten the background and reduce the contrast of the object image.

4.11.3 Transmitted Light Phase Contrast

The phase contrast method is ideal for examining thin uncolored samples, e.g. individual cells of cell cultures. Generally, the human eye cannot detect phase differences (variations in refractive index or thickness) within the different cell components.

The phase contrast method uses the optical modulators "annular phase diaphragm" and "phase ring" to convert the small phase differences in intensity differences which are visible to the human eye. The interference of different beams in the intermediate image is important for the generation of such images.

With the aid of the optically defined ring channel "annular phase diaphragm and phase ring", the bright direct light portions are attenuated and provided with a constant phase shift. The indirect light portions, however, which are diffracted by different cell particles, bypass this optical channel and their phase is affected by the difference in the sample's refractive index and thickness.

In the intermediate image plane, the partial beams are thus differently affected and achieve interference and strengthen or weaken each other (constructive and destructive interference) – depending on their phase. As a result, these interferences create image contents with intensity differences visible to the human eye.

4.11.4 Transmitted Light Differential Interference Contrast

The transmitted light DIC contrast method allows for a high-contrast vivid display of transparent sample details.

The light is linearly polarized by a polarizer and is separated into two beams in a birefringent prism. These pass through two neighboring sample locations at a short distance and experience different path differences there due to differences in refractive index and sample thickness. Both beams are then combined in a second birefringent prism and have the same polarization after passing the analyzer. Therefore both beams can interfere in the intermediate image and the path differences are thus converted into intensity differences represented by a gray scale. A compensator, e.g. λ -plate, may be used for a consecutive conversion of the gray scale in a color scale.

4.11.5 Transmitted Light PlasDIC Microscopy

PlasDIC can be used independently from the material of the sample holder.

The contrast method gives a relief-like image and is especially well suited for thicker objects. The contrast is adjustable. It is possible to contrast the cavities of microtiter plates up to the edge. It is not necessary to use cultivation holders with a glass base.

4.11.6 Transmitted Light Polarization Contrast

The transmitted light polarization contrast method is used for samples which change the polarization of the light. Such samples are called birefringent. Examples include crystals, minerals or polymers. If such birefringent substances are observed between crossed polarizers, the birefringent portion of the sample appears bright while its surroundings remain dark.

4.11.6.1 Detecting Birefringence

A birefringent substance can be recognized by turning the sample by 360° between crossed polarizers. The sample should show four bright and four dark appearances during the turning procedure. During the turning procedure, interference colors appear that range from gray (mostly for biological samples) through white, yellow and red until blue, depending on birefringence, thickness as well as sample orientation. The interference colors may be of the first or of a higher order.

4.11.6.2 Determination of the Polarization Direction

The determination of the polarization direction of n_v or n_v' respectively (polarization direction with the absolute or relative largest index of refraction) and n_a or n_a' respectively (polarization direction with the absolute or relative smallest index of refraction) relative to the morphological directions, e.g. of crystal surfaces, crystal needles or fibers, provide an important signature of the material. This method is also used in the diagnosis of bio-crystals (e.g. gout and pseudo-gout).

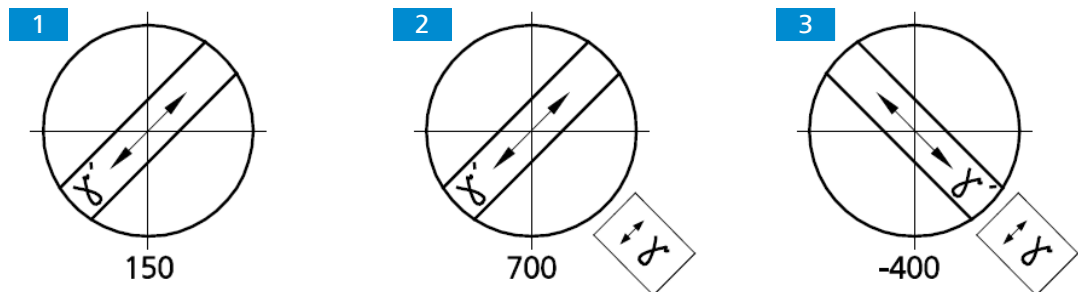

Fig. 37: Determining the polarization direction n_v' using a synthetic fiber as an example

When the lambda compensator is put in, the sample changes its color depending on its orientation (northeast-southwest or northwest-southeast). Like the sample, the lambda compensator is a birefringent object, but it has a defined path difference of 550 nm and a maximum oscillation direction n_v pointing strongly to northeast-southwest.

The changes in color are based on optical interference. It is necessary to compare the interference colors (path differences) in both diagonal positions (northeast-southwest and northwest-southeast).

The path difference results from the interference of the polarization of the sample and the polarization of the lambda compensator.

The largest path difference occurs when the polarization direction of the sample or the absolute or relative largest index of refraction (n_v or n_v') is parallel to the largest polarization direction of the lambda compensator. The sample appears then e.g. in blue-green **2**.

The smallest path difference occurs when the direction of polarization of the sample with the absolute or relative smallest index of refraction (n_a or n_a') is perpendicular to the polarization direction of the lambda compensator. The sample then appears e.g. yellow **3**.

The gray-white color appearing first in the bright position in the above example **1** corresponds to a path difference of 150 nm (according to the Michel-Lévy color chart).

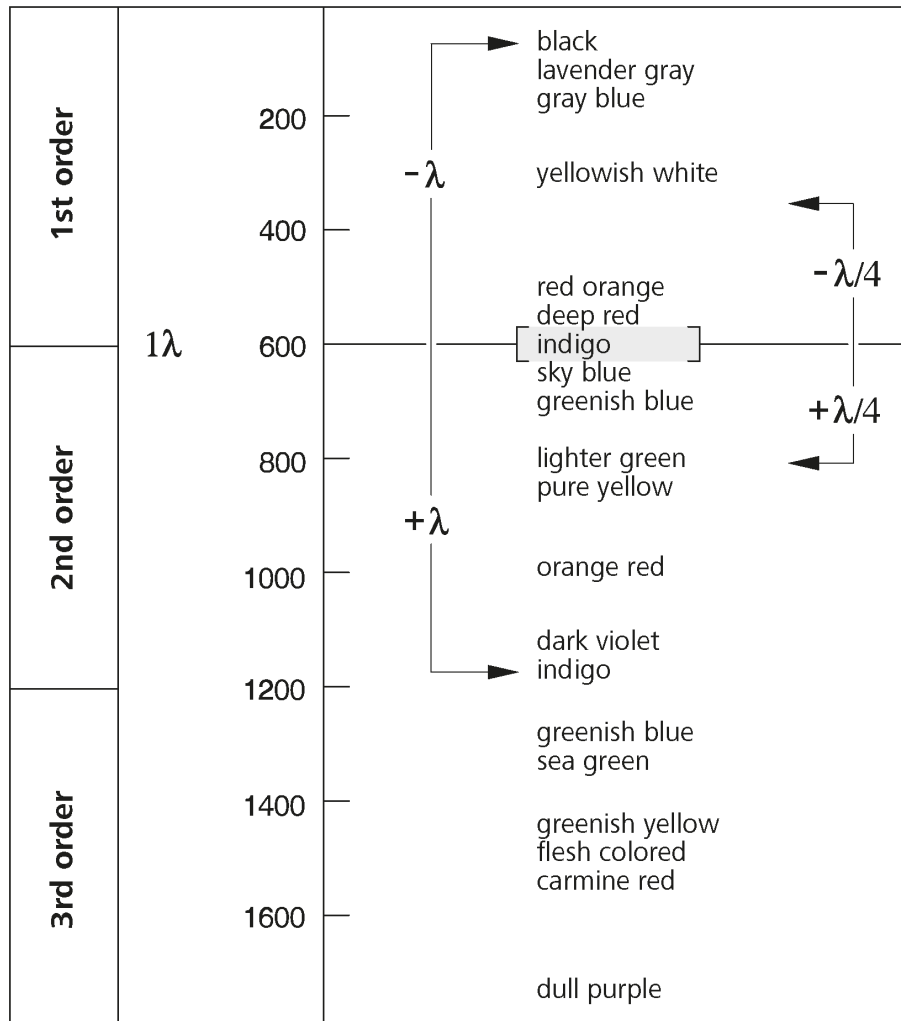

Fig. 38: Schematic diagram of the color charts developed by Michel-Lévy

When the lambda compensator is brought into the beam path, the non-birefringent "surroundings" of the synthetic fiber appear dark red, which corresponds to the path difference of the compensator of 550 nm (1st order interference color for the path difference of 550 nm corresponds to 1 λ).

If the polarization direction (n_v or n_v') of the birefringent sample to be examined is parallel to the principal polarization direction (n_v) of the lambda compensator, i.e. in the northeast-southwest direction, the path difference of the sample (e.g. gray-white: 150 nm) and the path difference of the lambda compensator (red: 550 nm) add up. This results in a color change of the sample from grayish white to greenish-blue (resulting path difference = 700 nm).

If the polarization direction of the birefringent sample to be examined is perpendicular to the principal polarization direction of the lambda compensator, i.e. in the northwest-southeast direction, the path difference of the sample (e.g. gray-white: 150 nm) is subtracted from the path difference of the compensator (red: 550 nm). In this case, the interference color of the sample visibly changes from gray-white to orange (resulting path difference = 400 nm).

4.11.6.3 Measuring Path Differences

Measuring compensators are required for the accurate measurement of path differences. These compensators reset, i.e. compensate the path difference produced by the sample to zero (first order black). While the addition position as well as the subtraction position are of interest for the methods described above, only the subtraction position is relevant for measurements. Path differences in the sample can assume very small values ($1/50 \lambda$ or 10 nm) and very large values (greater than 10λ or approx. 5500 nm and more) and thus determine the compensator appropriate for the measurement.

The suitable compensator is determined as follows:

- If more or less strong interference colors appear on the sample, the path difference ranges approximately between $1/2 \lambda$ and 5λ .
The suitable compensator is:
B 0-5 λ tilting compensator
- If the sample-side color changes from light gray/white to a strong interference color, when a lambda compensator (473704-0000-000) is inserted in the compensator slot, the path difference is $(1/4 - 1/2) \lambda$.

NOTICE A prerequisite for the occurrence of the color change effect may be the evaluation in two sample positions rotated at an angle of 90° from one another. For this purpose, rotate the centered stage (by 2 click stops).

The suitable compensator is:

B 0-5 λ tilting compensator

or the DE SENARMONT compensation method up to 1λ using the 546/4 nm SENARMONT compensator.

NOTICE The DE SENARMONT compensation method requires the use of the rotatable analyzer.

- After insertion of the lambda compensator and rotation of the sample by 90° , the interference color remains white; in this case, however, it is a "higher-order white" and thus the path difference is $> 5 \lambda$.
The suitable compensator is:
K 0-30 λ tilting compensator
- A dark gray appearing as the interference color indicates a very small path difference ($\lambda/10$ or 54.6 nm).

4.11.6.4 Circular Polarization Contrast

Unlike standard polarization contrast, circular polarization contrast does not show any dark (extinction) positions that depend on the angle of rotation (azimuth) of the sample relative to polarizer or analyzer. This means that, while you are rotating the stage, the image will always look the same, as there are no bright and dark positions. With optical anisotropy all transparent samples show the interference colors that are characteristic to them.

4.11.6.5 Transmitted Light Polarization for Conoscopic Observation

The determination of the optical character of transparent and weakly absorbent crystals is used to diagnose crystals. This method is also termed conoscopy. Its main application is classical mineral microscopy. However, it also facilitates the identification and characterization of synthetic crystals, industrial minerals and plastics (e.g. films).

For the classification (and thus identification) of crystalline matter, the examination of the interference image in the objective pupil delivers more valuable information than that obtained by viewing the sample itself. The interference image becomes visible in the eyepiece if an additional optical system (fixed or focusing Bertrand lens or, in the basic version, the auxiliary microscope or diopter) is used.

In contrast to orthoscopy, this technique is called conoscopy, because here the sample is ideally illuminated through a wide-open cone. In practical microscopic work, this means that the condenser front lens (0.9) must be in the light path, the aperture stop fully open, and the objective, too, should be a high-aperture type.

4.11.7 Reflected Light Brightfield Contrast Using the KÖHLER Method

Reflected light brightfield contrast is the easiest and most commonly used RL contrast method. It is used to examine optically opaque samples or samples as e.g. cut, polished, etched metal or ores.

In order to obtain an image as close as possible to the object, not only the so-called direct beam bundles but also the indirect ones, i.e. the beam bundles diffracted and scattered at the preparation details, are of essential importance. According to ABBE, the larger the indirect beam components are, the more true to the object the microscopic image is.

The cone of light emerging from the reflected light light source is reflected on a color-neutral beam splitter before it passes through the objective which is focused on the sample surface (so-called condenser function). The objective collects the light reflected on the sample and creates, with the tube lens, the microscopic intermediate image. This image can then be examined visually or documented using a camera.

4.11.8 Reflected Light Darkfield Contrast Using the KÖHLER Method

The reflected light darkfield contrast method is applied when samples are examined, which do not have areas with different reflectivity (ideal brightfield samples), but which show deflections (as scratches, cracks, dust particles etc.) on the plane surface. All such light-scattering details appear bright in the darkfield, while the reflective plane areas remain dark.

4.11.9 Reflected Light DIC and C-DIC Contrast

The reflected light DIC and the reflected light C-DIC contrast methods (DIC = Differential Interference Contrast; C-DIC = Circular polarized light–differential interference contrast) are used for the high-contrast imaging of small height differences on the surface of opaque samples.

C–DIC is a polarization–optical differential interference contrast method where, unlike conventional DIC according to Nomarski, the DIC prism is arranged in circular, not linear, polarized light. Consequently, the interference contrast generated is invariant in relation to the oscillation orientation of the DIC prism, and so the latter can be rotated directionally in accordance with the characteristics of the object. This means that the stage does not need to be rotated while the relationship with the object is preserved. For the user, this means more information and an increase in sample throughput.

4.11.10 Reflected Light TIC Contrast

The reflected light TIC contrast method (Micro-interferometry; TIC = Total Interference Contrast in the circular polarized light) is used in imaging and measuring sample structures that exist in different azimuths.

Evaluation of the measured values

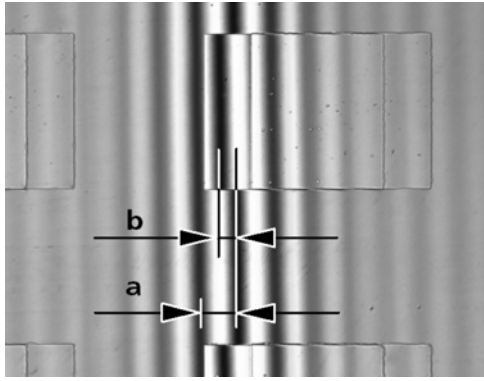

Fig. 39: Interference stripes

The values **a** (distance between interference stripes) and **b** (offset of the interference stripes along the step) are determined with the aid of an eyepiece reticle micrometer or with a micrometer eyepiece.

If working with white light (without an interference filter), set $\lambda = 550$ nm. When interference filters are used, it is important to apply the focal point of their wave lengths.

The measured path difference depends on the aperture and increases with the illumination aperture.

The step height SH is determined with the following formula:

$$SH = \frac{n\Delta}{2} = \frac{\lambda b}{2a}$$

Where

SH = step height in nm

n = refractive index of the environment, mostly air ($n = 1$)

Δ = phase difference

a = distance between interference stripes

b = offset of the interference stripes along the step

λ = wave length of the illumination in nm

The following correction values must be considered depending on the objective used:

Objective	Correction factor k
5x/0.15	1.0057
10x/0.25	1.0161
10x/0.30	1.0236
20x/0.4	1.0436
20x/0.50 and 50x/0.75	1.0718
50x/0.60	1.1111
50x/0.75 and 100x/0.75	1.2038
50x/0.80	1.2500
50x/0.90 and 100x/0.90	1.3929
100x/0.95	1.5241

Tab. 1: Correction depending on aperture

Example

$a = 11 \text{ mm}$; $b = 5 \text{ mm}$; $\lambda = 550 \text{ nm}$; objective 20x/0.50

$$SH = \frac{\lambda \cdot b \cdot k}{2a} = \frac{550 \text{ nm} \cdot 5 \text{ mm} \cdot 1.0718}{22 \text{ mm}} = 134 \text{ nm}$$

Attention:

- If the step and its surroundings are made from different materials, the phase jumps characteristic for the material must be considered. For all non-conducting materials, the phase jump is 180° , and for all semi-conductors only slightly different from 180° . Consequently, errors in the step-height determination may be neglected. However, if metals on top of glass are investigated, the results may become erroneous. The phase jumps given in table 2 were calculated for vertical light incidence and compact materials. They can serve as approximate values, since the phase jumps depend on the layer thickness and the angle of incidence of the light. An accurate determination of the layer thickness is possible only when the complete sample is covered with a homogeneous layer and the path differences are measured.
- If the layers and the steps are transparent, as with silicon dioxide on silicon, for example, the interference stripes can change their colors, so that the determination of the order of the interference may become problematic. This complication can be avoided if the sample is covered with a homogeneous layer.

Material	Phase jump Φ
Copper	140.0°
Gold	142.5°
Silver	151.0°
Bismuth	151.0°
Nickel	157.0°
Iron	157.5°
Zinc	159.0°
Platinum	160.0°
Aluminum	160.0°
Tin	160.5°
Chrome	165.0°
Coal	160.0°
Graphite	165.0°
Silicon	177.0°
Glass	180.0°

Tab. 2: Calculated phase jumps for compact material and vertical incidence of light

For a thickness measurement (step height), half the difference of the phase jump at the respective interface must be considered:

$$SH = \frac{\Delta}{2} - \frac{\delta\phi}{2}$$

Example: extreme case of copper on glass

$$\Phi_{\text{copper}} = 140^\circ, \quad \Phi_{\text{glass}} = 180^\circ,$$

consequently, for the additional thickness due to the phase jump we obtain

$$\frac{\delta\phi}{2} = 20^\circ$$

or

$$\frac{\lambda}{18} = 30 \text{ nm}$$

Without consideration of the phase jump at the respective interfaces, the thickness value would be too large by 30 nm.

4.11.11 Reflected Light Polarization Contrast

Reflected light polarization contrast is a contrast method suited for cut, polished surfaces of mineral ore, coal, ceramics, special metals, and alloys. Depending on the orientation of the crystals and the sample details, the cut surfaces often react differently when reflected in linearly polarized light.

The illumination light is polarized by the polarizer before passing through the objective onto the sample surface where it is reflected. Then the beam parts experience path differences depending on the structure and polarization of optical rotations which, when passing through the analyzer, are represented by different shades of gray. With the aid of a compensator with a λ -plate the gray contrast can be converted into a color contrast.

Even when examining "dark" sample surfaces, a rotatable $\lambda/4$ plate in front of the objective (anti-reflective cap) helps eliminate the reflections which are inevitable when working with objectives with very low magnification.

A sample is bireflectant when the sample details show differences in brightness and color which change when the direction of vibration of the polarizer or the stage is rotated. For samples with low bireflectance using the analyzer with a rotatable lambda plate is recommended.

4.11.12 Reflected Light Fluorescence Contrast

The reflected light fluorescence contrast method is used to show fluorescent substances in typical fluorescent colors in high contrast. The light originating from a high-performance light source in a reflected light fluorescence microscope passes through a heat protection filter onto an excitation filter (bandpass). The filtered short-wave excitation radiation is reflected by a Dichroic Beam splitter and is focused on the sample through the objective. The sample absorbs the short-wave radiation before emitting longer-wave fluorescence radiation (Stokes' Law). This radiation is then captured from the image side by the objective and passes through the Dichroic Beam splitter. Last, the beams pass through a emission filter (longpass/bandpass) and only the long-wave radiation emitted by the sample passes.

The spectra of the excitation and the emission filter must match very closely. They must be inserted in a Reflector Module FL EC P&C reflector module together with the according Dichroic Beam splitter.

5 Installation

Perform only the installation work described in this document. All other installation work not described may only be carried out by an authorized ZEISS service representative.

5.1 Unpacking and Setting up the Microscope

- Procedure**
1. Open the packaging.
 2. Take the microscope, all assemblies, and accessories out of the packaging.
 3. Check them for completeness as per delivery note.
 4. Check all parts for damaging.
 5. Place the microscope on a vibration-free, level, and non-inflammable surface.

It is recommended to keep the original packing and store it away for later use, e.g. for stowing the microscope during periods of non-use or for returning the microscope to the manufacturer for repair.

5.2 Assembling the Base Plate on the Stand

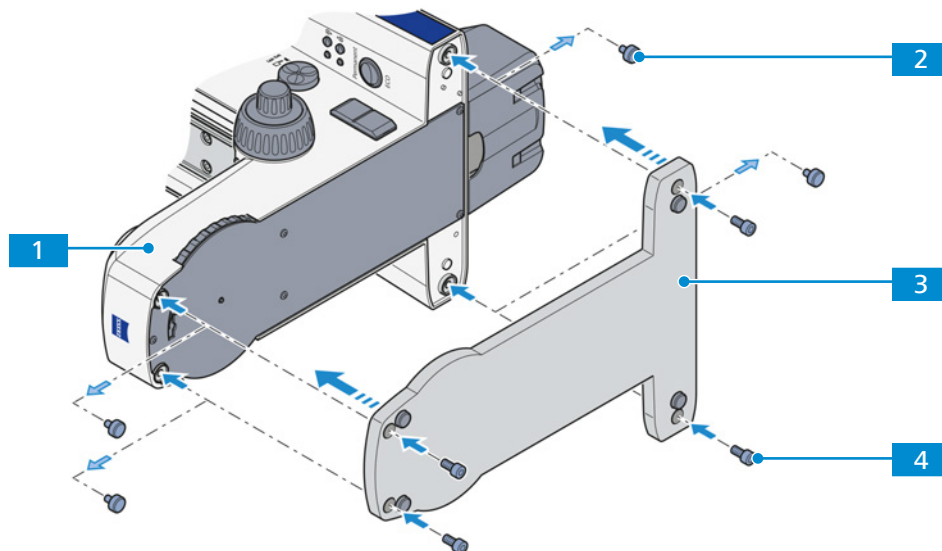

Parts and Tools  Hex key, 6.0 mm

- Procedure**
1. Remove the four rubber feet **2** from the base plate of the stand **1**.
 2. Align the base plate **3** with the stand.
 3. Insert four hexagonal socket screws (M6) **4** into the holes in the base plate.
 4. Tighten the screws.

Proceed in the reverse order for removal.

5.3 Assembling the Upper Part of the Stand on the Stand Column

The present section applies to the following microscope type:

- Axioscope 5 Vario (430035-9150-000)

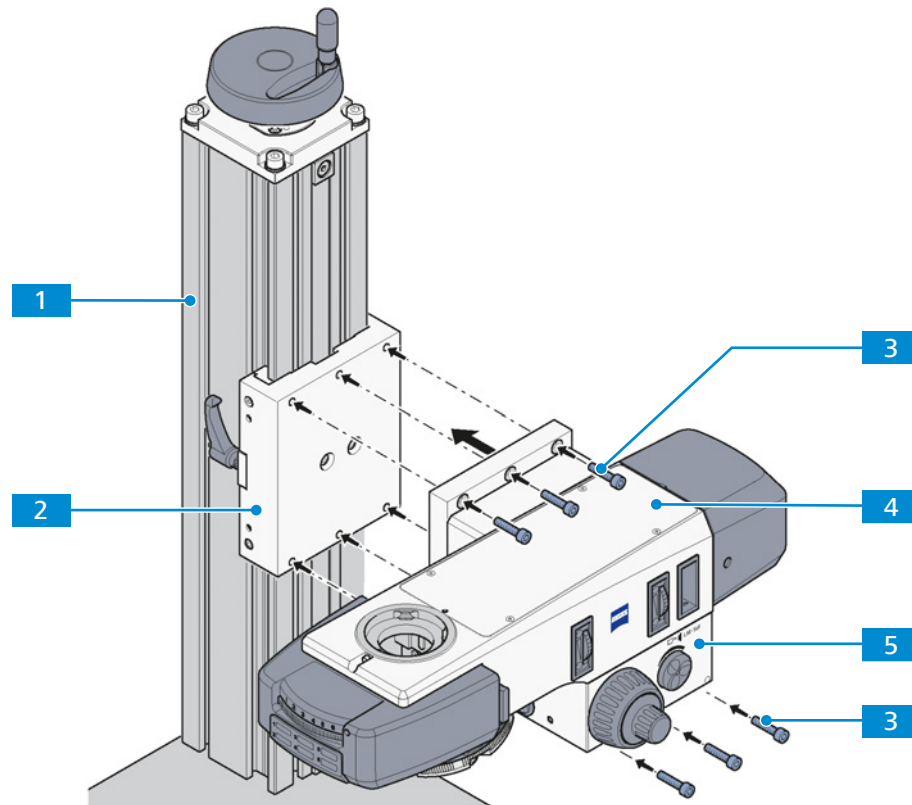

- Procedure**
1. Unpack the upper part of the stand **4** with gear box **5** and the stand column **1**.
 2. Position the upper part of the stand on the mounting plate **2** of the stand column.
 3. Tighten the upper part of the stand with six hex screws **3**.

5.4 Assembling the Binocular Tube

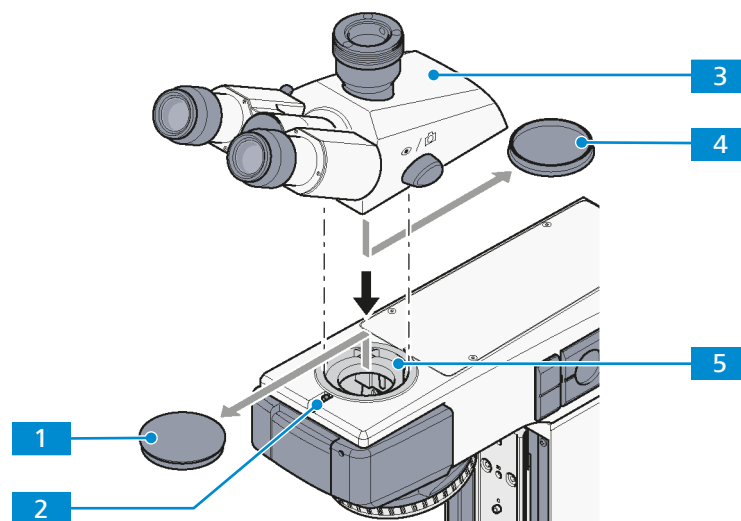

Parts and Tools 🔧 Hex key, 3.0 mm

- Procedure**
1. Loosen the clamping screw **2**.
 2. Remove the dust cap **1** from the dovetail ring mount on the stand side.
 3. Remove the dust cap **4** from the underside of the tube **3**.
 4. Hold the tube at an angle, insert it with the dovetail ring into the stand mount **5** and turn into a horizontal position.
 5. Rotate the tube into the desired observation position.
 6. Re-tighten the clamping screw with the hex key.

Proceed in the reverse order for removal.

5.5 Assembling Components into the Binocular Tube

The following components can be inserted into the tube:

- eyepieces
- auxiliary microscope
- pinhole diaphragm

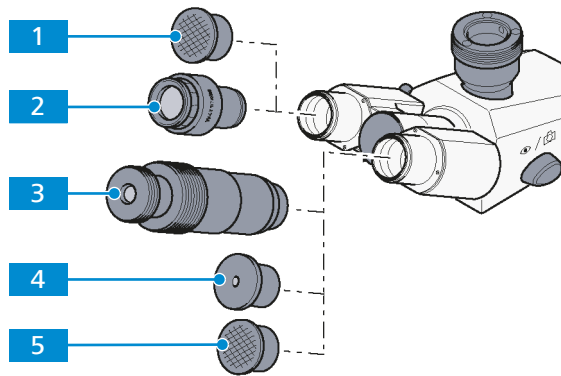

- Procedure**
1. Remove both dust caps **1** / **5** from the tube.
 2. Remove both eyepieces **2** from the box and insert them into the eyepiece socket of the tube to the stop.
NOTICE Before inserting Pol eyepieces with tubes without upright reticles, the orientation screw on the reverse side of the eyepieces must be unscrewed. The eyepieces cannot otherwise be fully inserted.
 3. Instead of an eyepiece insert an auxiliary microscope **3** or pinhole diaphragm **4** in one eyepiece socket.

Proceed in the reverse order for removal.

5.6 Assembling the Objectives

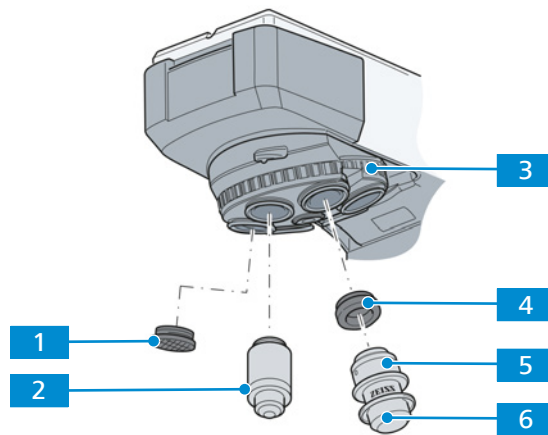

- Procedure**
1. Use the focus drive to fully lower the mechanical stage or lower the stage carrier by loosen the clamping handle.

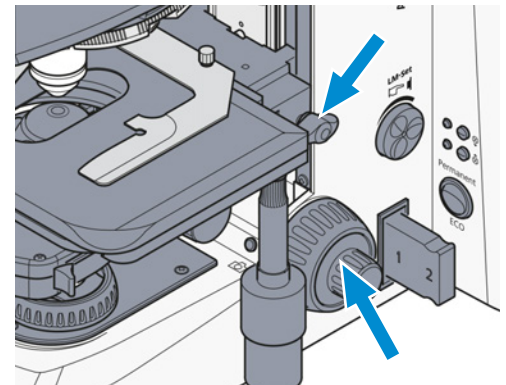

2. Remove the dust protection caps **1** from the appropriate openings in the nosepiece.
3. Remove objectives **2** from the case and screw them into the nosepiece **3**.
4. Carefully screw the objective into the opening. Start with the smallest magnification factor (set up clockwise) in nosepiece position 1.
5. Make sure it engages properly in the nosepiece's thread.
6. Instead of an objective, the sample marker **5** with an adapter W0.8/M27 **4** can be screwed on in any desired nosepiece position.
7. Apply the protective cap **6** to prevent sample marker from drying out.
8. Always replace the dust protection caps on any empty positions on the nosepiece.

NOTICE

Dust-sensitive components

If dust-sensitive components e.g. unused nosepiece openings remain uncovered, particles may enter the microscope and may damage its optics and mechanics permanently.

- ▶ Always close unused nosepiece openings with blind caps.

5.7 Assembling the Reflector Turret

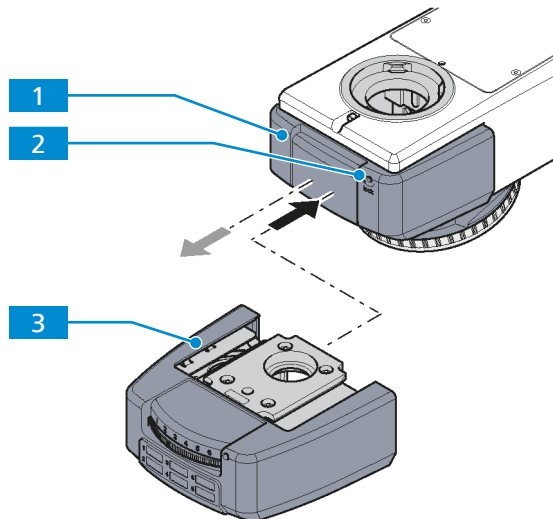

Parts and Tools  Hex key, 3.0 mm

Procedure

1. Insert the hex key into the hole **2**.
2. Turn the locking screw counterclockwise.
3. Remove the cover cap **1** to the front.
4. Push the reflector turret **3** with the reflector modules P&C (e.g. reflector turret with 6 coded positions) into the upper part of the stand until it stops.
5. Hold the reflector turret and tighten the locking screw.

Proceed in the reverse order for removal.

5.8 Assembling the Stage Carrier

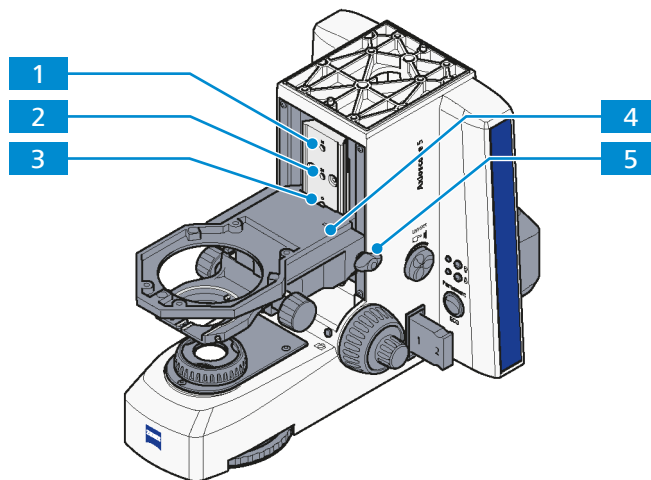

Procedure

1. Screw the shoulder screw **3** into the appropriate opening of the stand.
 - Opening with mark **0** **3**: **No** sample space extension is mounted.
 - Opening with mark **30** **2**: The sample space extension for **30 mm** is mounted.
 - Opening with mark **60** **1**: The sample space extension for **60 mm** is mounted.
2. Loosen the wing screw **5**.
3. Insert the stage carrier **4** at a slight angle (beneath the shoulder screw) from the left into the guide.

4. Push the stage carrier straight in.
5. Tighten the wing screw **5** slightly.
6. Push the stage carrier along the guide upward until it engages in the shoulder screw.
7. Tighten the wing screw.
8. Check to ensure that the stage carrier is accurately positioned.

5.9 Assembling the Stage

5.9.1 Assembling the Stable Mechanical Stage and Specimen Holder

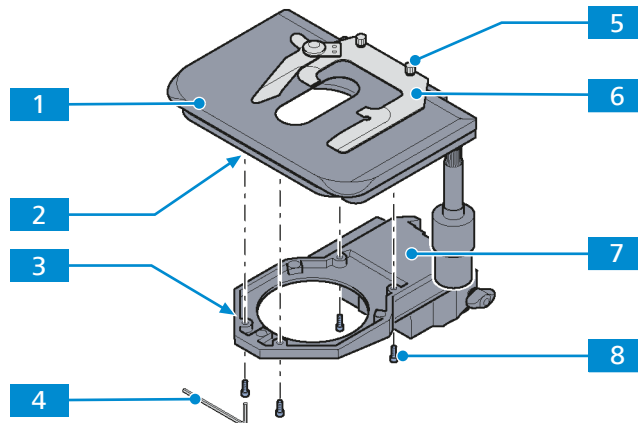

Parts and Tools  Hex key, 3.0 mm

Procedure

1. Place the stage **1** on the stage carrier **7** so that the threaded holes **2** on the bottom of the stage are positioned above the stage carrier openings **3** and hold the stage.
2. Insert four fastening screws **8** through the stage carrier from below and screw them into the bottom of the stage. Use the 3 mm hex key **4**.
3. Turn the stage to orient it in an XY direction and tighten the fastening screws.
4. Place the sample holder **6** on the stage and fasten the two clamping screws **5**.

Proceed in the reverse order for removal.

5.9.2 Assembling the Motorized Mechanical Stage on the Axioscope 7 Motorized Material Stand

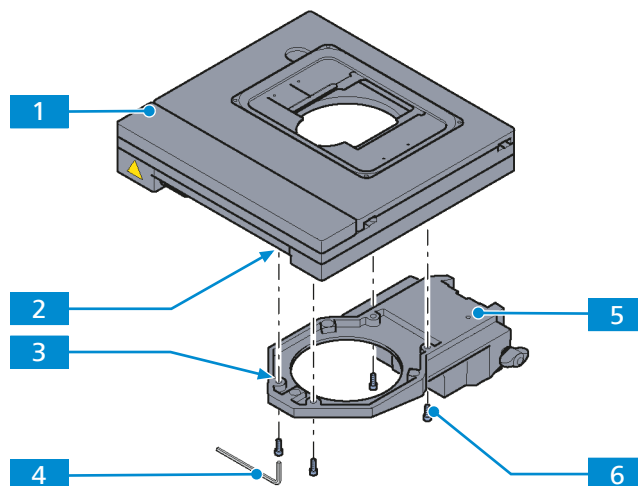

Parts and Tools 🔧 Hex key, 3.0 mm

Prerequisite ✓ *The stage carrier is removed [▶ 68] 5 from the stand.*

- Procedure**
1. Turn the stage 1 and the stage carrier upside down carefully.
 2. Match the threaded holes 2 in the bottom of the stage to the corresponding holes 3 in the carrier.
 3. Insert the four mounting screws 6 into the holes of the stage carrier.
 4. Align the stage in XY-direction.
 5. Tighten the screws. Use a 3 mm hex key 4.
 6. Install the stage carrier together with the stage on the stand.
 7. Plug the power cord connectors into the sockets on the stage 8 and on the stand 7.

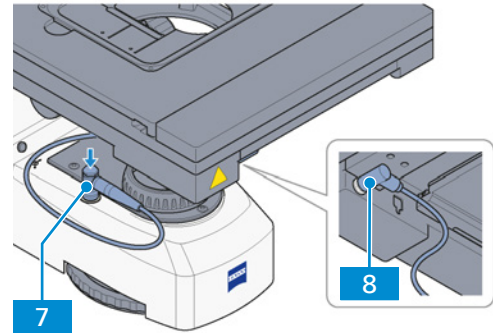

Proceed in the reverse order for removal.

5.10 Installing the Condenser Carrier

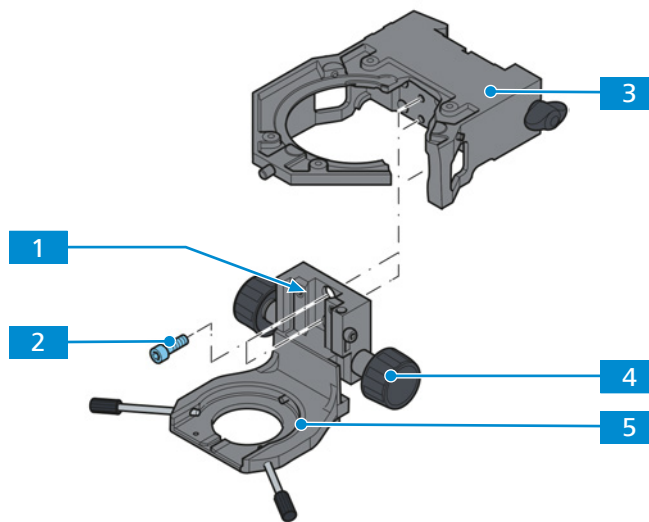

- Procedure**
1. With the focus knob 4 slide the guide of the condenser carrier 5 until the two screws 2 in the mounting holes 1 become accessible.
 2. Mount the condenser carrier on the stage carrier 3.
 3. Tighten the screws.
 4. Slide the condenser carrier firmly and straight up to the upper stop of the stage carrier.

5.11 Assembling the Dry Darkfield Condenser

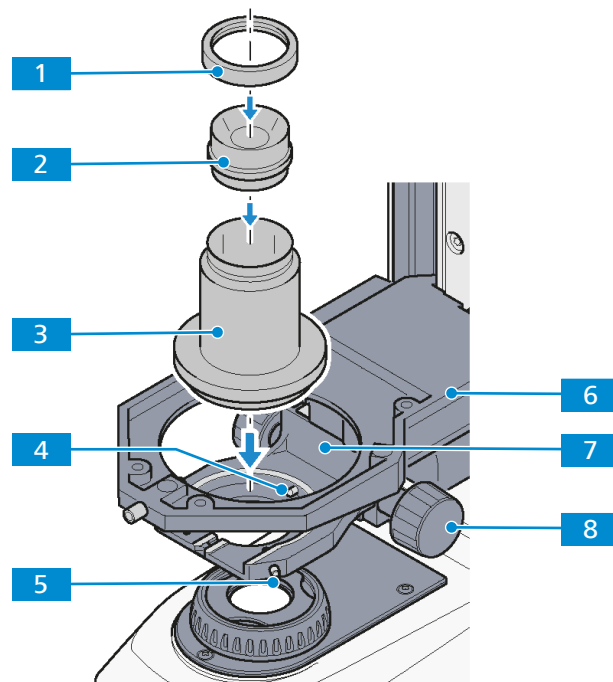

Procedure

1. Carefully move the stage carrier **6** with the focusing drive to the upper stop position.

NOTICE Damage due to collision. Make sure that the stage does not collide with the objective.

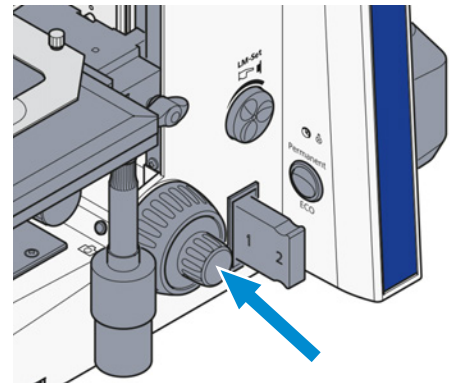

2. Using the knurled knob **8** for vertical adjustment, push the condenser carrier down as far as it will go.
NOTICE Damage due to collision. If using a low-power system, make sure that this does not come to rest on the luminous-field diaphragm.
3. Unscrew both centering screws **5** on the condenser carrier **7** until their ends are no longer visible.
4. Insert the darkfield condenser **2** in the condenser holder Z **3**.
5. Fix the darkfield condenser with the fastening ring **1**.
6. Press the condenser holder Z with the dovetail ring against the mainspring **4** of the condenser carrier until the condenser holder Z sits horizontally on the condenser carrier.
7. Screw in the centering screws until they engage with the dovetail ring of the condenser holder Z.

5.12 Assembling the Transmitted Light Source

Different light sources can be mounted for transmitted light:

- *HAL 100* [▶ 133]
- *LED 10* [▶ 145]

5.13 Assembling the Reflected Light Source

Different light sources can be mounted for reflected light:

- *HAL 100* [▶ 134]
- *LED 10* [▶ 145]
- *HBO 100* [▶ 141]
- *Colibri 3* [▶ 146]
- *HXP 120 V* [▶ 144]

5.14 Connecting the Microscope to the Mains

- Prerequisite**
- ✓ The microscope is switched off.
 - ✓ The power cord is unplugged.

- Procedure**
1. Connect the power cord to the mains socket of the stand.

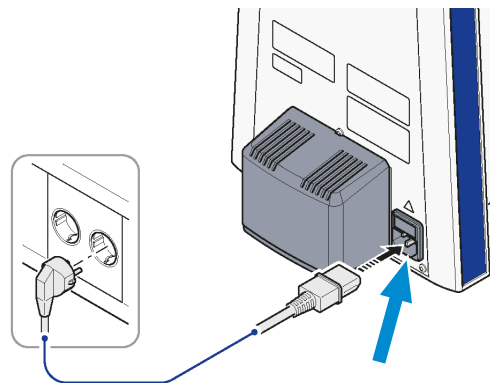

2. Connect the power cord to the mains.

Proceed in the reverse order for disconnecting the microscope from the mains.

6 Operation

This chapter describes switching on/off the microscope as well as the first operating steps with the microscope.

Info

For additional information and detailed descriptions, refer to further applicable documents or ask your ZEISS Sales & Service Partner.

Info

Further information on the software and its operation is available in the software's online help.

6.1 Prerequisites for Commissioning and Operation

The following basic prerequisites are necessary for commissioning and operation:

- This document was read prior to commissioning or operation and kept for further use.
- The chapter **Safety** was read and understood.
- The operator is acquainted with the general Windows-based programs.
- If required: Basic training and safety briefing were successfully completed.

6.2 Switching On the Microscope

- Prerequisite**
- ✓ The microscope is connected to the *mains* [▶ 72].
 - ✓ The required light source for transmitted light is *installed* [▶ 72].
 - ✓ The required light source for reflected light is *installed* [▶ 72].

- Procedure**
1. Switch the microscope on using the **power switch On/Off** on the left side.

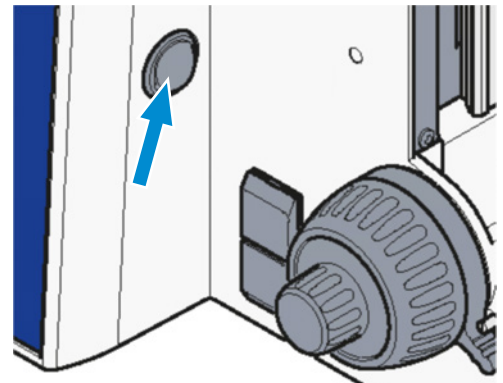

2. If HAL 100 or HBO 100 light sources are used, switch on the external power supply for the light source.

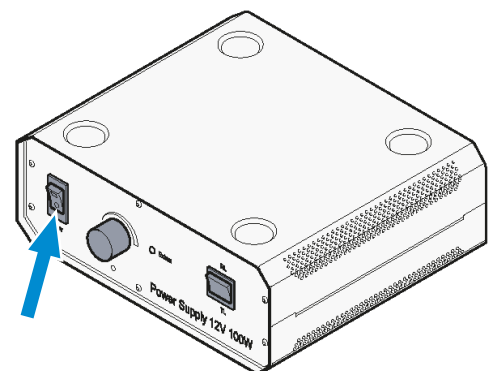

3. If used, switch on the HXP 120 V light source. Consult the instruction manual supplied with the light source.

6.3 Adjusting

6.3.1 Adjusting the Position of the Eyepieces

Info

The adjustment of the interpupillary distance is correct when you see only one round image while looking through the two eyepieces.

- Procedure**
1. Set the interpupillary distance by rotating the eyepiece tubes symmetrically toward or away from one another.



2. Set the viewing height by swivelling the whole eyepiece unit a full 180 ° upwards or downwards.

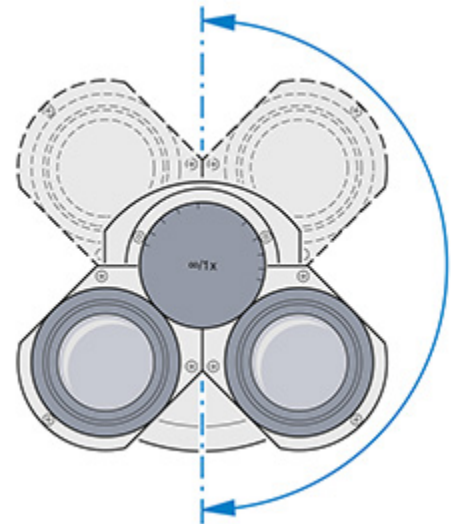

6.3.2 Focusing when Using Eyepiece Reticles

- Prerequisite**
- ✓ Two adjustable eyepieces are installed.
 - ✓ One eyepiece with reticle is installed.
 - ✓ A sample is positioned on the stage.

- Procedure**
1. Look through the eyepiece with the reticle. Focus the line of the reticle using the focusing ring of the eyepiece.
 2. Look through the eyepiece with the reticle. Focus the sample with the focusing drive.
→ Both the microscopic image and the eyepiece reticle are in focus now.
 3. Look through the eyepiece without reticle with your other eye. Focus the sample using the focusing ring of the eyepiece.
- ↳ Both microscopic images including the eyepiece reticle are in focus now.
From this point, use only the focusing drive for any subsequent focusing activity.

6.3.3 Adjusting the Upper Part of the Stand Vertically

The present section applies to the following microscope type:

- Axioscope 5 Vario (430035-9150-000)

The height of the upper part of the stand can be adjusted according to the size of the sample.

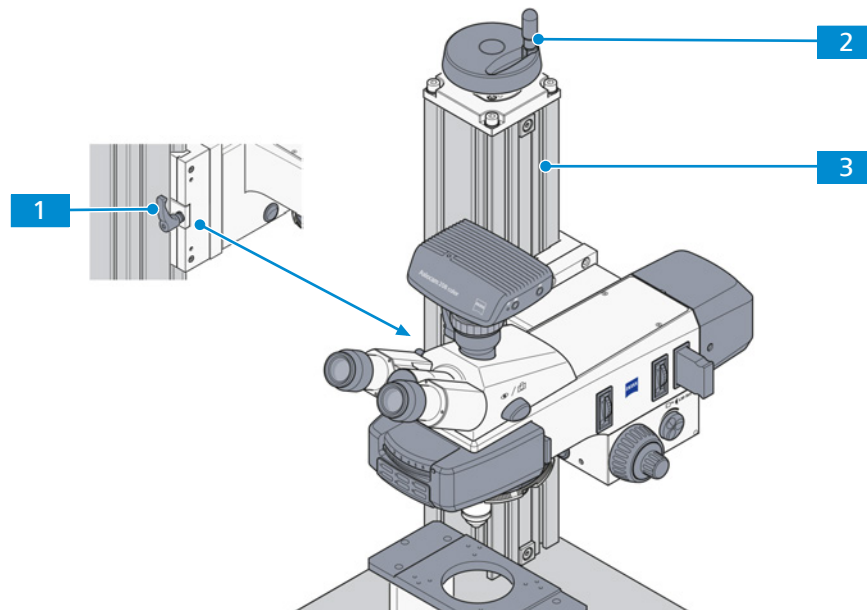

- Procedure**
1. On the stand column **3**, loosen the release lever **1**.
 2. Use the handwheel **2** to adjust the height.
 3. Tighten the release lever.

6.3.4 Adjusting the Height Stop on the Condenser Carrier

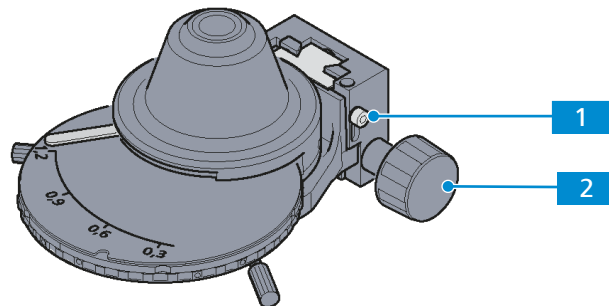

Parts and Tools  Hex key, 3.0 mm

- Prerequisite**
- ✓ The microscope is operational.
 - ✓ The condenser carrier is *installed* [[▶ 70](#)].
 - ✓ A sample is positioned on the stage.

- Procedure**
1. Loosen the set screw of the height stop **1**.
 2. Focus the sample.
 3. Close the luminous-field diaphragm.
 4. Adjust the condenser vertically **2** until you get a sharp image.
 5. **NOTICE** The sample and the objective can be damaged when the sample is lifted out.
Carefully raise the condenser by a small amount without lifting out the sample.
 6. Tighten the set screw of the height stop.

6.3.5 Adjusting the Height Stop on the Focusing Drive

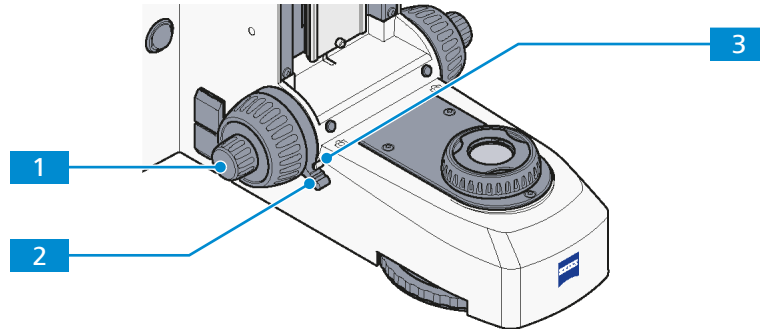

- Prerequisite**
- ✓ The microscope is operational.
 - ✓ A sample is positioned on the stage.

- Procedure**
1. Turn the clamping lever of the height stop **2** counterclockwise, towards the pin stop **3**.
 2. Use the focusing drive **1** to move the stage to the highest position allowable without risking to collide with sample holder or objective.
 3. By turning the clamping lever clockwise, clamp the stop again.

6.3.6 Using the Light Manager Function

6.3.6.1 Enabling the Light Manager Function

- Prerequisite**
- ✓ The microscope is operational.

- Procedure**
1. Press one of the **Snap** button and the **Intensity/LM** knob simultaneously for at least 1.5 seconds.

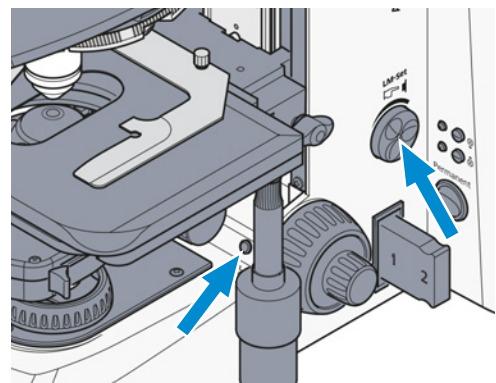

→ The indicator light blinks in the following sequence: GREEN / GREEN / GREEN

6.3.6.2 Saving Light Intensity Values Using the Light Manager Function

- Prerequisite**
- ✓ The microscope is operational.
 - ✓ The Light Manager function is *enabled* [▶ 76].

- Procedure**
1. Switch to the first objective and/or reflector (if available) positions of interest using the knurled rings (or slider).

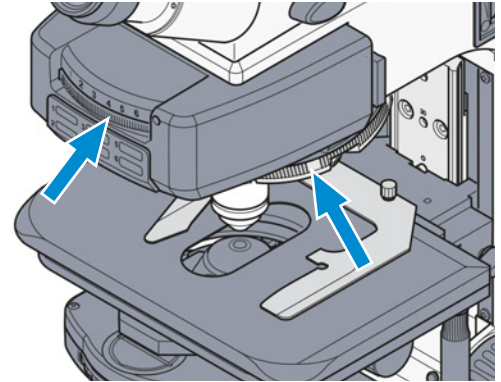

2. Set the desired light intensity by turning the **Intensity/LM** knob.

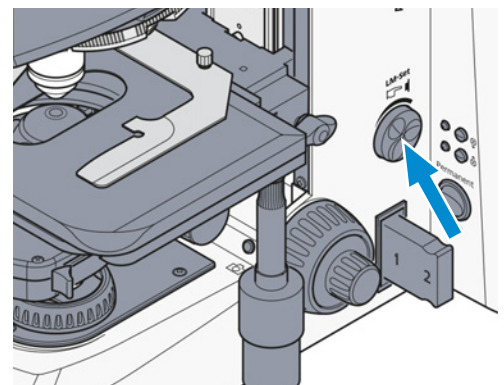

3. Press the **Intensity/LM** knob for at least 1.5 seconds.
 - The light intensity for this objective/reflector combination is saved.
 - When using LED as light source, the LED is switched off for 300 ms. This is visible through the eyepieces and serves as an indicator for the user.
 4. Switch to the second objective/reflector position.
 5. Press the **Intensity/LM** knob for at least 1.5 seconds.
 - Now a ratio between the first and the second objective/reflector combinations is established.
 6. Repeat to set light intensity values for more objective/reflector combinations.
- ↳ After switching on the microscope, the previous setting of the Light Manager will be restored.

6.3.6.3 Enabling/Disabling the Dazzle Protection Function

By factory default, the dazzle protection function is enabled.

- Procedure**
1. Axioscope 5: Press the left **Snap** button and the right **Snap** button simultaneously for at least 1.5 seconds to switch between enabled and disabled dazzle protection function.
 Axioscope 7: Press the left **Stage control** button and the right **Snap** button simultaneously for at least 1.5 seconds to switch between enabled and disabled dazzle protection function.
 - Dazzle protection function disabled: The indicator light blinks ORANGE twice.
 - Dazzle protection function enabled: The indicator light blinks GREEN twice.

6.3.6.4 Disabling the Light Manager Function

- Prerequisite** ✓ The microscope is operational.
 ✓ The Light Manager function is *enabled* [▶ 76].

- Procedure** 1. Press one of the **Snap** button and the **Intensity/LM** knob simultaneously for at least 1.5 seconds.

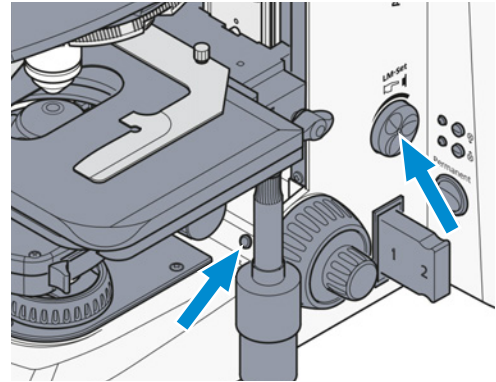

→ The indicator light blinks in the following sequence: GREEN / ORANGE / GREEN

6.3.7 Setting the ECO/Permanent Mode

- Prerequisite** ✓ The microscope is operational.

- Procedure** 1. Select the ECO or Permanent mode for microscope illumination using the **ECO/Permanent mode** switch.

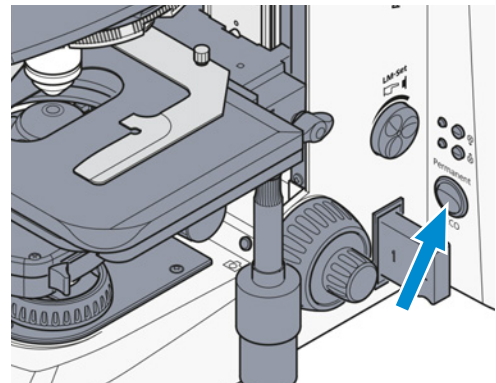

6.4 Setting Up for Transmitted Light Contrast Techniques

6.4.1 Setting Up for Transmitted Light Brightfield Microscopy Using the KÖHLER Method

- High-contrast sample slide

Every microscope (except the one with the Vario stand column) is configured to work with the transmitted light brightfield method. All available condensers (except special condensers like dark-field condensers) can be used for the transmitted light brightfield method.

- Prerequisite** ✓ The microscope is operational.
 ✓ The height stop of the condenser carrier is *adjusted* [▶ 75].
 ✓ The height stop of the focusing drive is *adjusted* [▶ 76].
 ✓ A suitable condenser for TL brightfield microscopy is installed.

Procedure 1. If required, push the **TL** button for transmitted light illumination.

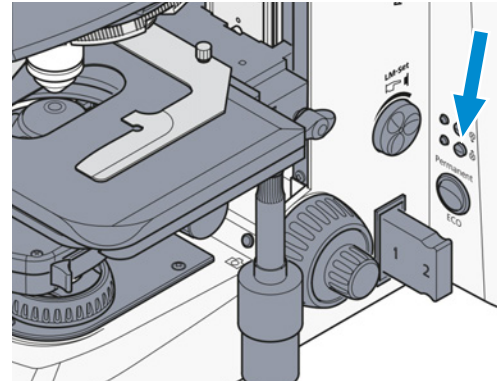

2. Adjust the image brightness using the **Intensity/LM** knob on the microscope stand.

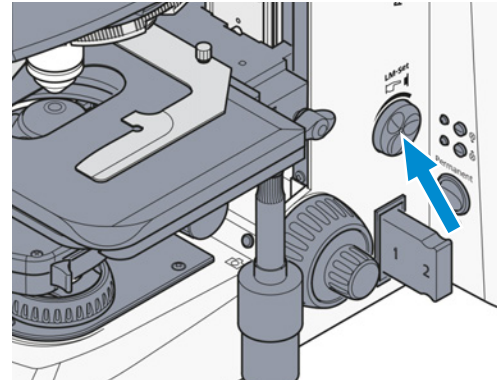

3. Insert the high-contrast sample into the sample holder of the stage.

4. Set position H (or B = brightfield), when using condensers with a turret/modulator disk and knurled ring.

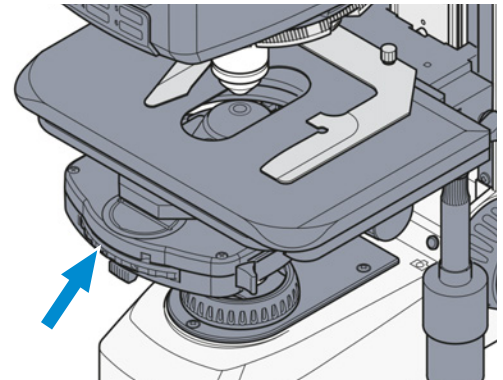

5. Swivel the front lens into the beam path with $\geq 10\times$ objectives, if condensers with a swiveling front lens are used.

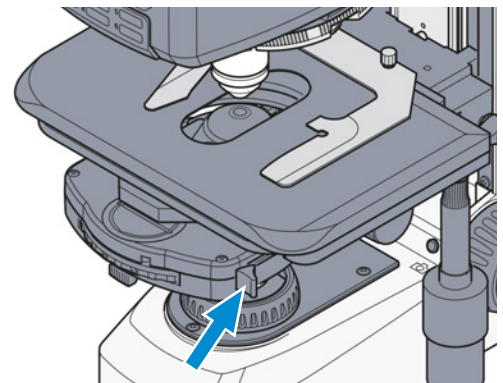

6. Set the condenser with the knurled knob for vertical adjustment to the upper stop.

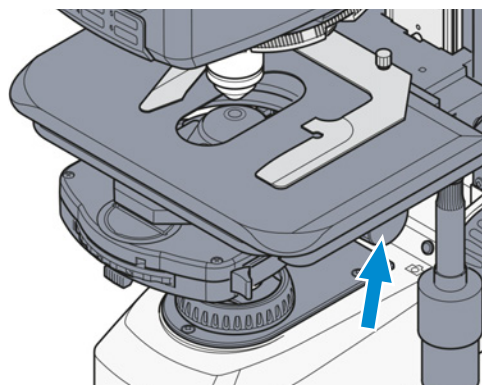

7. Swivel in the 10x objective on the nosepiece.

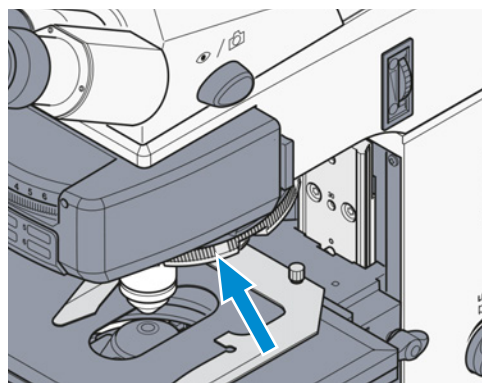

8. Focus the sample.

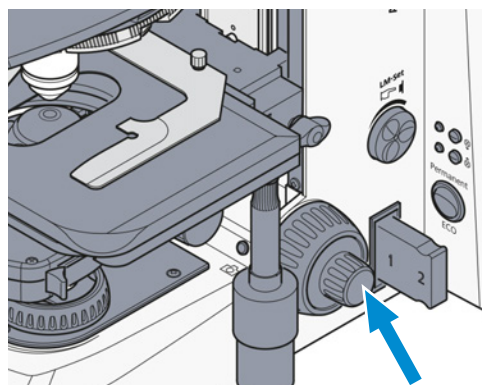

9. Close the luminous-field diaphragm until it is visible (even if not in focus) in the field of view

A

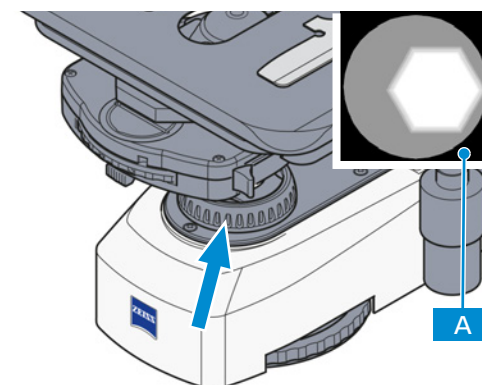

10. Turn the knurled knob for vertical adjustment to lower the condenser until the edge of the luminous-field diaphragm appears in focus **B**.

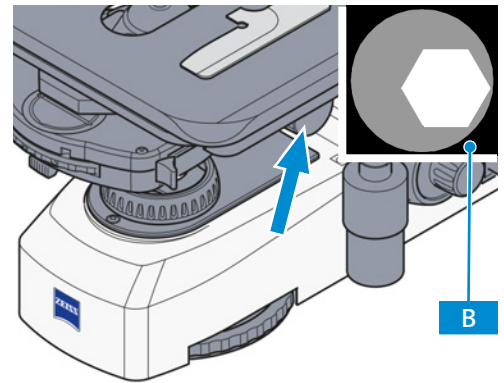

11. Center the luminous-field diaphragm using the two centering screws on the condenser carrier **C**.

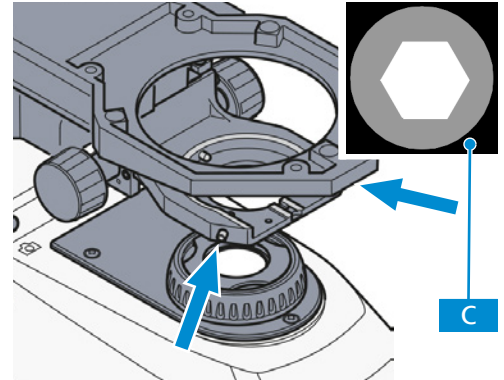

12. Open the luminous-field diaphragm until the edge of the diaphragm just disappears from the field of view **D**.

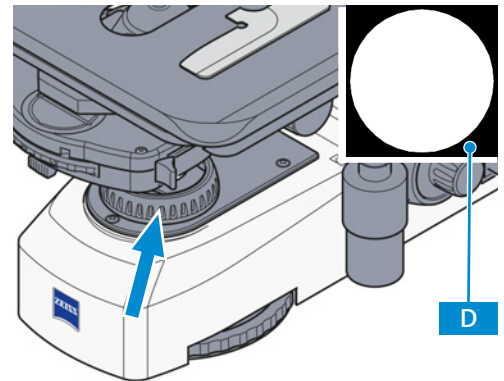

13. Remove an eyepiece from the binocular tube to adjust the aperture diaphragm (contrast).
 14. Look into the tube with the naked eye.
 15. Set the aperture diaphragm with the adjusting lever to between $2/3$ - $4/5$ of the diameter of the exit pupil of the objective **E**.

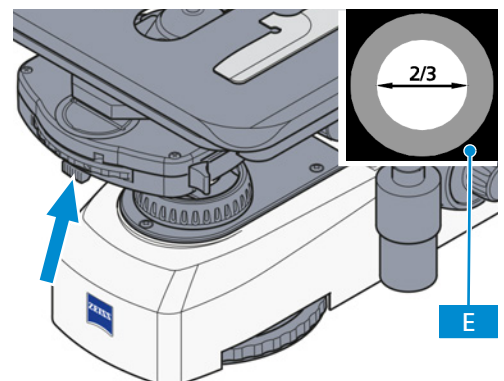

→ In most applications, this aperture diaphragm setting provides optimal contrast at almost ideal resolution, and is therefore the best compromise for the human eye.

16. Reinsert the eyepiece into the binocular tube.
 17. Remove the high-contrast sample.

Info

Every change of objective will result in a change in sample field size and objective aperture, together with a possible slight change in centering, so that for optimal results the field and aperture stop adjustments must be repeated.

With objectives < 10x, the front lens of the condenser (if swivelable) must be swivelled out of the beam path and the aperture stop completely opened. For better contrast with such large object fields, the field aperture should be closed to a certain extent. Overclosing should be avoided so as not to impair the uniformity of the illumination of the field of view.

6.4.2 Setting Up for Transmitted Light Darkfield Microscopy Using the KÖHLER Method

- Prerequisite**
- ✓ The microscope is operational.
 - ✓ The height stop of the condenser carrier is *adjusted* [▶ 75].
 - ✓ The height stop of the focusing drive is *adjusted*. [▶ 76]
 - ✓ A suitable condenser for transmitted light darkfield microscopy is *installed* [▶ 71].
 - ✓ The illumination is adjusted for *transmitted light brightfield microscopy* [▶ 78].

- Procedure**
1. Set the modulator disk to position D (or DF = darkfield).

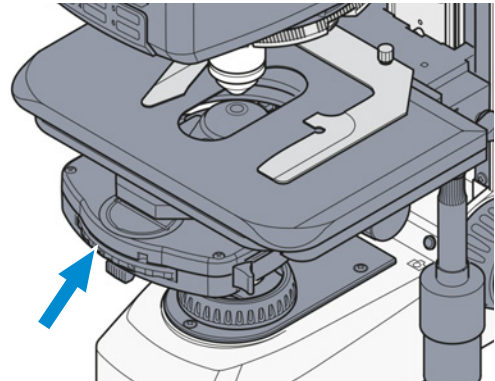

2. Turn the knurled knob for vertical adjustment of the condenser to the upper stop.

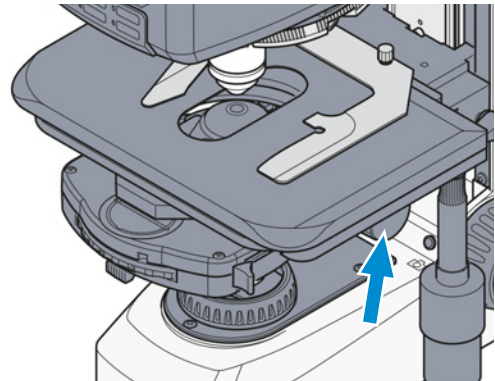

3. Swivel the objective with the highest possible aperture into position on the nosepiece.

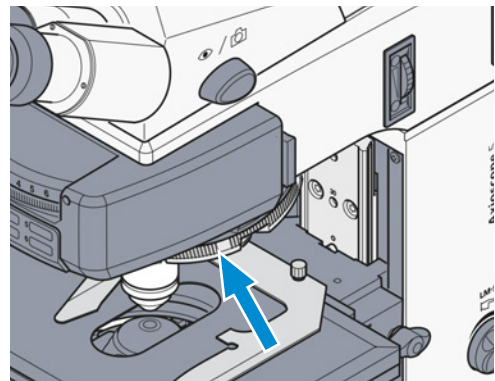

4. Place the sample on the stage.

5. Focus the sample.

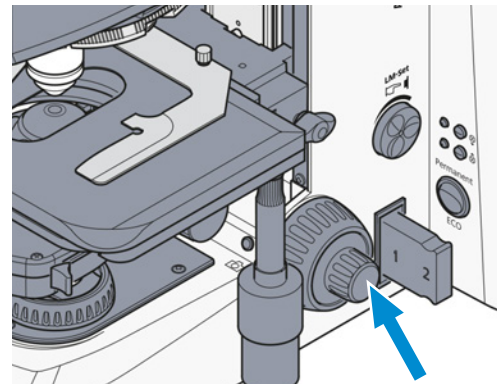

6. Close the luminous-field diaphragm enough to make it visible in the field of view (even if blurred).

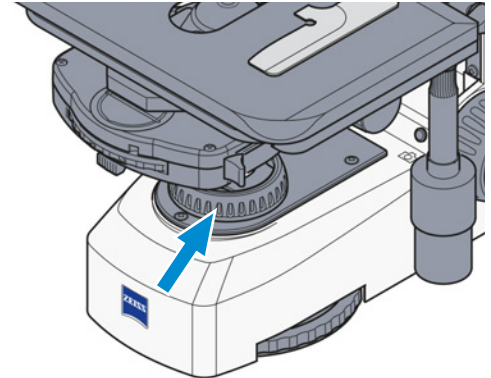

7. Lower the condenser until the edge of the luminous-field diaphragm appears sharp using the knurled knob for vertical adjustment.

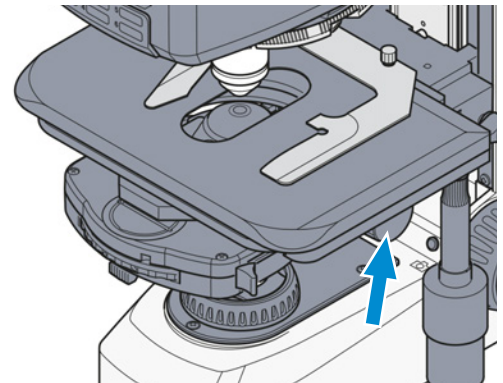

8. Center the luminous-field diaphragm on the condenser carrier using the adjustment screws.

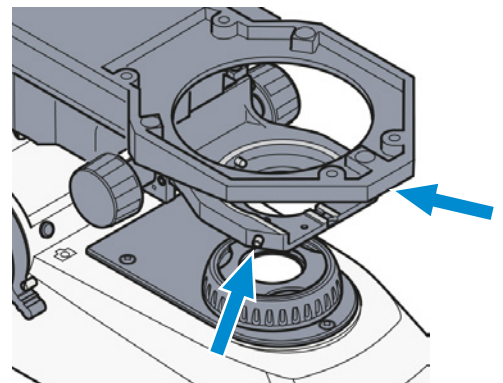

9. Open the luminous-field diaphragm enough to make the edge of the diaphragm disappear from the field of view.
10. Remove one eyepiece or replace it with the auxiliary microscope.
11. Check the centering of the darkfield diaphragm in the objective exit pupil.
 - The objective exit pupil must appear homogeneously dark.
12. If necessary, *center* [▶ 189] the darkfield diaphragm.
13. If required, remove the auxiliary microscope.
14. Insert the eyepiece.

15. Adjust the condenser height using the knurled knob for vertical adjustment until no more lighter areas are visible in the field of view .
16. Adjust the luminous-field diaphragm diameter to the size of the field of view.

Info

Darkfield microscopy requires samples to be considerably cleaner than in other techniques. In particular, fingerprints, dirt or dust particles have a negative effect, as they brighten the background of the field of view and decrease the contrast of the object image.

6.4.3 Setting the Darkfield Contrast with a Dry Darkfield Condenser

- Prerequisite**
- ✓ The microscope is operational.
 - ✓ The dry darkfield condenser is *installed* [▶ 71].
 - ✓ Low-power system, polarizer or Lambda plate are swivelled out of the beam path.

- Procedure**
1. Move the condenser up until the end stop.
 2. Place the sample on the stage.
 3. Adjust the illumination intensity sufficiently bright.
 4. Swivel in an objective with small magnification (e.g. 5x or 10x)
 5. Focus the sample.
 6. Place a sample so that its details are evenly visible in the field of view.
 - The image of the field diaphragm is easier to identify.
 7. Close the luminous-field diaphragm until the end stop.
 8. Lower condenser until the edge of the field diaphragm appears sharp (luminous-field diaphragm focus level).
 - An increasing or decreasing light ring is visible, when moving the focus upwards or downwards from the field diaphragm focus level (so called circular "breathing" of the field diaphragm depiction).
 9. Center the field diaphragm image with both centering screws on the condenser carrier.
 10. Swivel in the desired objective.
 11. If necessary, focus the sample.
 12. Focus the luminous-field diaphragm with the knurled knob for vertical adjustment.
 13. Open the luminous-field diaphragm enough to make the edge of the diaphragm disappear from the field of view.

6.4.4 Setting the Darkfield Contrast with an Immersion Oil Darkfield Condenser

- Prerequisite**
- ✓ The microscope is operational.
 - ✓ An immersion oil darkfield condenser is *installed* [▶ 71].
 - ✓ An immersion oil objective is installed.
 - ✓ Low-power system, polarizer or Lambda plate are swivelled out of the beam path.

- Procedure**
1. Move the condenser up until the end stop.
 2. Place a drop of immersion oil (without bubbles, if possible) on the center of the condenser front lens.
 3. Place the sample on the stage.
 - The immersion oil disperses between the condenser and the sample holder.
 4. Slightly move the mechanical stage back and forth to dissipate any air bubbles in the immersion oil.
 5. Adjust the illumination intensity sufficiently bright.
 6. Open the luminous-field diaphragm completely.

7. Swivel in an objective with small magnification (e.g. 10x).
8. Focus the sample.
9. Center the luminous-field diaphragm on the condenser carrier with the adjustment screws.
10. Focus the sample.
11. Place a drop of immersion oil on the sample.
12. Swivel in an immersion oil objective.
13. Focus the sample.
14. Close the luminous-field diaphragm until the end stop.
15. Lower the condenser until the edge of the field diaphragm appears sharp (luminous-field diaphragm focus level).
16. Center the field diaphragm on the condenser carrier with the adjustment screws.
 - The luminous field diaphragm appears only as a circle segment on the edge of the viewing field due to the high magnification of the immersion oil objective. As a result, the focusing and centering of the field diaphragm must be repeated. The field diaphragm is centered properly, when the edge of the luminous field diaphragm is centered or equidistant from the viewing field edge.
17. If the light intensity is too low, open the luminous-field objective slightly.
18. For a sharply focused sample, open the sharply set field diaphragm enough to make the edge of the diaphragm disappear from the field of view.
19. Adjust the focus level of the condenser with the knurled knob for vertical adjustment to improve the contrast.
20. For immersion oil objectives with an iris diaphragm, the contrast can be further optimized by turning the adjustment of the iris diaphragm.

6.4.5 Setting Up for Transmitted Light Phase Contrast Microscopy

- Prerequisite**
- ✓ The microscope is operational.
 - ✓ Phase contrast objectives with the phase rings **PhC 1**, **PhC 2** or **PhC 3** are installed [▶ 67].
 - ✓ Condenser with modulator disk with centerable ring diaphragms **PhC 1**, **PhC 2** and **PhC 3** is installed [▶ 163].

- Procedure**
1. Swivel the phase contrast objective into the beam path (e.g. **Ph1**).
 2. Swivel in the annular phase diaphragm on the condenser's revolver disk with the same labeling as the objective (e.g. **Ph1**).
 3. Replace one eyepiece [▶ 66] with an auxiliary microscope.
 4. With the adjusting fixture on the auxiliary microscope, focus the annular phase diaphragm and the phase ring in the objective exit pupil.
 5. Check the centering and the overlap of the lighter annular phase diaphragm (in the condenser) with the darker phase ring (in the objective). Both rings must be centered and overlapping

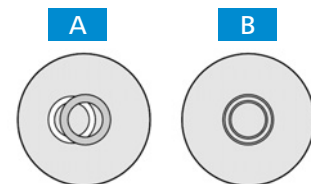

6. If the overlap is not exact **A**, recenter [▶ 190] the lighter annular phase diaphragm.
7. Remove the auxiliary microscope and replace the eyepiece.

Info

To increase the image contrast, a green 32 x 4 interference broadband filter can be mounted on the field stop or inserted into the color glass carrier (if available).

6.4.6 Setting Up for Transmitted Light DIC Microscopy

Info

The DIC method works with polarized light. It is disturbed when birefringent elements, e.g. foils, are put between polarizer and analyzer, as is sometimes done when doing a histological incision. The same situation occurs with Petri dishes or sample holders which have a plastic base. In these cases we recommend using the PlasDIC method.

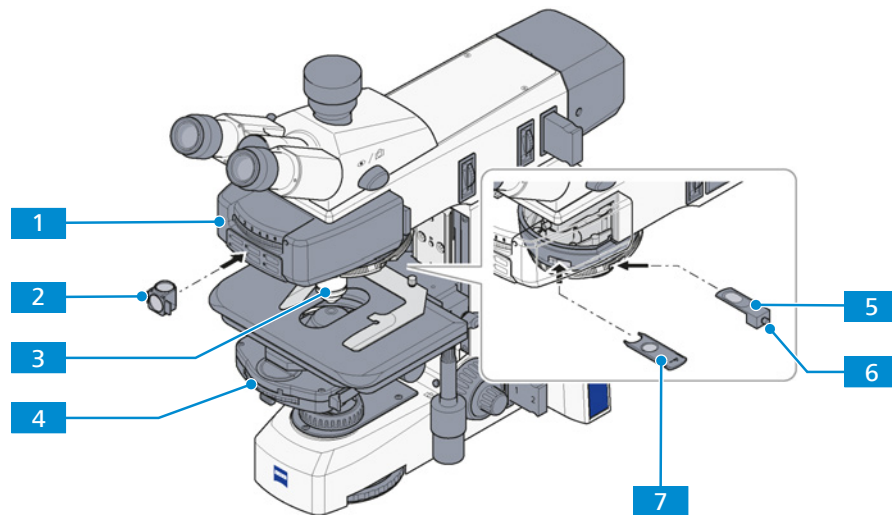

- Prerequisite**
- ✓ The microscope is operational.
 - ✓ Objective equipped with DIC fixtures, e.g. EC Plan-NEOFLUAR, is installed [▶ 67].
 - ✓ Nosepiece with slot for DIC slider is installed.
 - ✓ DIC slider, compatible with the objectives in use, is available.
 - ✓ Condenser with turret disk containing DIC prisms (e.g. condenser, achromatic-aplanatic 0.9 H D PhC DIC) is installed.
 - ✓ The analyzer module ACR P&C for transmitted light in the reflector turret/slider or the analyzer slider D/A fixed or rotatable in conjunction with a mounted intermediate plate for analyzer slider 12x46 is installed.

- Procedure**
1. Swivel the DIC compatible objective **3** into the beam path.
 2. Slide the according DIC slider into the slit of the appropriate objective position.
 3. Swing in the analyzer module **2** on the reflector turret **1** (or slide the analyzer slider **7** into the intermediate plate for analyzer sliders).
 4. On the condenser **4**, swing in the DIC prism (use position **DIC**).
 5. Adjust field diaphragm and aperture diaphragm according to the *KÖHLER method* [▶ 78].
 6. With the knurled screw **6** on the DIC slider **5**, adjust the optimal contrast. Symmetrical adjustment of the DIC slider along its middle position lets the sample details appear as if they were elevated or deepened.
 7. Put the compensator λ into the opening above the nosepiece to create a chromatic DIC contrast, if required.

6.4.7 Setting Up for Transmitted Light PlasDIC Microscopy

- Prerequisite**
- ✓ The microscope is operational.
 - ✓ Abbe condenser with modulator disk and objective-dependent 2 mm slit diaphragm for PlasDIC (A-Plan 10x and LD A-Plan 20x) or 4.5 mm slit diaphragm for PlasDIC (in all other cases) is installed.
 - ✓ One of the following objectives is *installed* [▶ 67]:
A-Plan 10x, 20x, 40x;
LD A-Plan 20x, 32x, 40x;
LD Plan-Neofluar 20x, 40x, 63x
 - ✓ DIC slider, compatible with the objectives in use, is available.
 - ✓ The analyzer module ACR P&C for transmitted light in the reflector turret/slider or the analyzer slider D/A fixed or rotatable in conjunction with a mounted intermediate plate for analyzer slider 12x46 is installed.

- Procedure**
1. Fully open the aperture diaphragm of the condenser.
 2. Place the sample on the stage.
 3. Swing the condenser position with the 2 or 4.5 mm slit diaphragm for PlasDIC into the beam path.
 4. Increase the brightness.
 5. Swing in the analyzer module on the reflector turret (or slide the analyzer slider into the intermediate plate for analyzer sliders).
 6. Swivel the PlasDIC compatible objective into the beam path.
 7. Slide the according DIC slider **1** into the slit of the appropriate objective position.

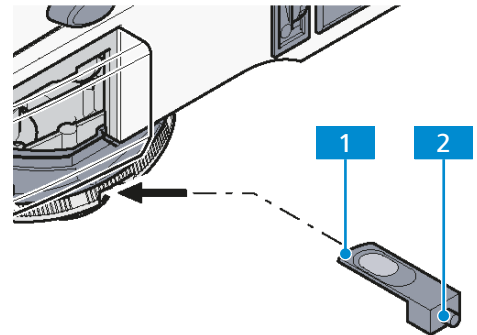

8. With the knurled screw **2** on the DIC slider, adjust the optimal contrast.
 - The structures are visible in relief or in pseudo-darkfield. The relief display provides the best contrast.

6.4.8 Setting Up for Transmitted Light Polarization

The following requirements must be fulfilled:

- The microscope is operational.
- Strain-free objectives are installed in the *nosepiece* [▶ 67].
- The Pol rotary stage is *installed* [▶ 155].
- A condenser with polarizer or the D Polarizer is *installed* [▶ 174].
- The analyzer module Pol ACR P&C for transmitted light in the reflector turret/slider or the analyzer slider D fixed or with lambda plate is installed.
- A depolarizer for avoiding unwanted polarizing effects is installed.
- The microscope is adjusted for *transmitted light brightfield microscopy* [▶ 78].
- The Pol rotary stage is *centered* [▶ 156].
- The Pol objectives are *centered* [▶ 179].

6.4.8.1 Detecting Birefringence

For more information about the method, see chapter *Detecting Birefringence* [▶ 57].

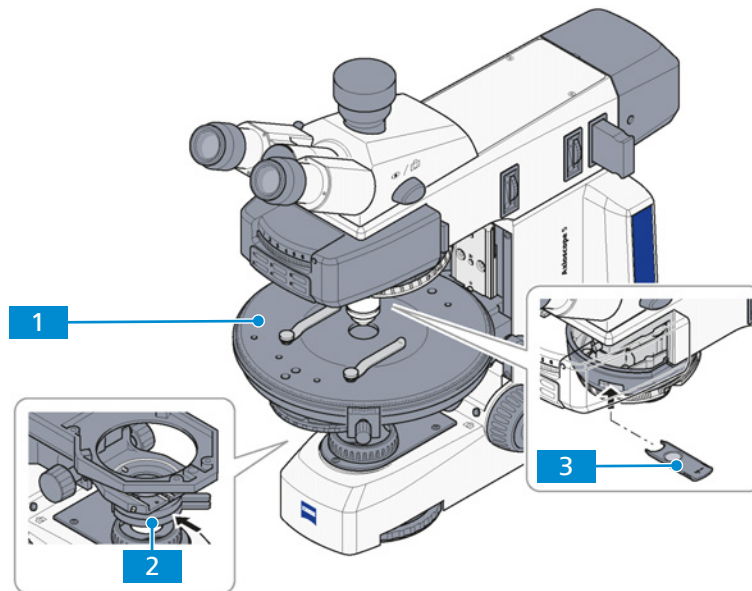

- Procedure**
1. Swing the polarizer **2** into the beam path.
 2. When using a rotatable polarizer, position it to 0°.
 3. Put the analyzer **3** into the slit for the compensator.
 - The field of view appears dark.
 4. Bring the sample into the field of view.
 5. With the rotary stage **1**, turn the sample.
 - Normally, birefringent (anisotropic) objects will now show the interference color and intensity variations during rotation between crossed polarizers. Optically anisotropic substances may remain dark when an isotropic direction, e.g. from optically single-axle or double-axle crystals, is oriented parallel to the observation direction.

6.4.8.2 Determination of the Polarization Direction

For more information about the method, see chapter *Determination of the Polarization Direction* [▶ 57].

- Prerequisite** ✓ An eyepiece with cross hair reticle is *installed* [▶ 66].
 ✓ The Pol adjustment sample for polarization microscopy is available.

- Procedure**
1. Swing the polarizer into the beam path.
 2. When using a rotatable polarizer, position it to 0°.
 3. Put the analyzer into the slit for the compensator or swing analyzer module on the reflector turret/slider.
 - The field of view appears dark.
 4. Place the Pol adjustment sample on the microscope.
 5. Turn the rotary stage until the adjustment sample appears dark.
 6. Remove the analyzer from the beam path.
 7. Align the reticle of the eyepiece along the split cracks of the adjusting sample.
 8. Return the analyzer into the beam path.
 9. Remove the adjustment sample.
 - The forward direction of the polarizer and analyzer is parallel to the cross hair in the reticle (polarizer east-west, analyzer north-south).
 10. Turn the rotary stage with the sample, e.g. a synthetic fiber, until the sample reaches maximal darkness.
 - The fiber is parallel to one of the two lines in the cross hair orientation.
 11. Turn the rotary stage by approx. 45° until the longitudinal axis of the fiber is pointing in northeast-southwest direction.
 - The sample shows the strongest brightness (diagonal position). It can have any color in this position.
 12. Slide in the lambda compensator (possible only if used with screw-in analyzer in tube or intermediate plate).
 - The sample changes its color depending on its orientation (northeast-southwest or northwest-southeast).

6.4.8.3 Measuring the Path Differences

For more information about the method, see *Measuring Path Differences* [▶ 59].

- Prerequisite** ✓ The correct inter-pupillary distance in the binocular tube is set.

- Procedure**
1. Accurately position the sample to be examined on the center of the eyepiece reticle.
 2. Limit the aperture to a value of about 0.2.
 3. Turn the rotary stage until the sample is almost extinguished, i.e. **completely dark**, and set the 45° locking position.
 4. Rotate the stage **once** (by 45°) so that the sample is in a diagonal position (sample becomes bright).
 5. *Determine* [▶ 59] the suitable compensator.
 6. Insert the determined compensator into the slot as far as it will go.
 7. Use the enclosed operating instructions for measurement preparation and measurement procedure.

6.4.8.4 Circular Polarization Contrast

For more information about the method, see *Circular Polarization Contrast* [▶ 59].

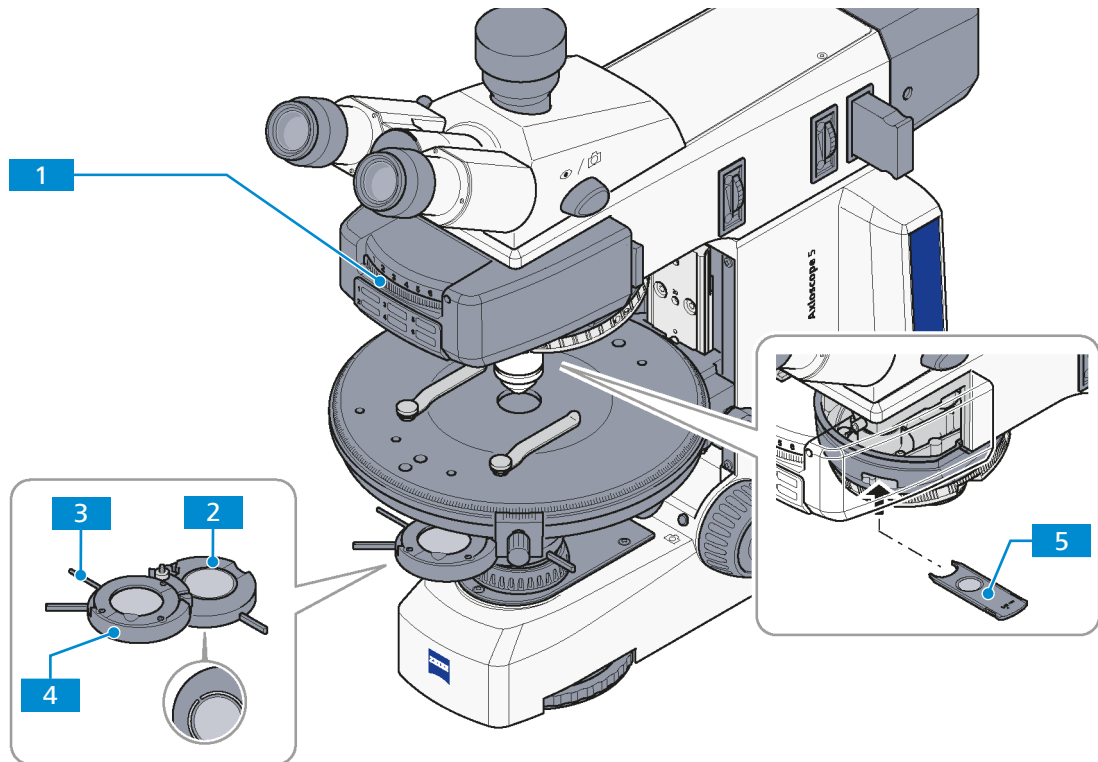

- Prerequisite**
- ✓ The circular polarizer D including the corresponding lambda/4 plate is installed.
 - ✓ The analyzer module is installed in the reflector turret or the stand is equipped with the intermediate plate for analyzer slider and the analyzer slider is available.
 - ✓ The lambda/4 compensator (6x20) is available.

- Procedure**
1. Remove the sample.
 2. Swivel the lower part **2** of the circular polarizer into the light path up to the click stop.
 3. Swing in the analyzer module on the reflector turret **1** or insert the analyzer slider into the intermediate plate.
 4. At full light intensity, assess the extinction (darkening) of the field of view without sample.
 5. Push the lambda/4 compensator **5** into the compensator slot above the nosepiece as far as it will go.
 6. Swivel the upper part **4** of the circular polarizer into the light path.
 7. Rotate the lever of the lambda/4 plate **3** of the D circular polarizer until the field of view appears dark gray.
 - The lever points 45° to the right.
 - The maximum extinction is obtained.
 8. Place the sample on the stage.
 - The samples appear constantly and independently of the stage rotation in their specific interference color, which depends on the material, sample thickness and orientation.

9. For the detection of gout or pseudo-gout, select crystal needles that are oriented in the gamma direction (see marking on the lambda plate).
 - If the crystal needles oriented parallel to the gamma direction of the lambda plate are yellow, and the crystal needles lying at a right angle to the gamma direction are blue, the crystals are monosodium urate crystals (gout).
 - If the crystal needles oriented parallel to the gamma direction of the lambda plate are blue, and the crystal needles lying at a right angle to the gamma direction are yellow, the crystals are calcium pyrophosphate crystals (pseudo-gout).

6.4.8.5 Transmitted Light Polarization for Conoscopic Observation

For more information about the conoscopic observation, see chapter *Transmitted Light Polarization for Conoscopic Observation* [▶ 59].

6.4.8.5.1 Simple Conoscopy Using the Auxiliary Microscope or the Diopter

- Prerequisite**
- ✓ Strain-free objectives are installed in the *nosepiece* [▶ 67].
N-Achroplan 50x/0.9 Pol objective or EC Plan-Neofluar 40x/0.9 Pol objective
 - ✓ The Pol rotary stage is *installed* [▶ 155].
 - ✓ Pol binocular photo tube is installed or eyepiece with crossline micrometer 14:140 and adjustment aid for polarization microscopy are available.
 - ✓ The achromatic-aplanatic 0.9 H Pol condenser or 0.9 Pol condenser is installed.
 - ✓ The D polarizer (rotatable or fixed) is installed.
 - ✓ Analyzer slider or D Pol analyzer module in the reflector turret or reflector slider are available.
 - ✓ The microscope is adjusted for *transmitted light brightfield microscopy* [▶ 78].

- Procedure**
1. Place the sample on the stage.
 2. Focus the sample.
 3. Swivel the polarizer.
 4. Move the analyzer into the light path.
 5. If you do not use the Pol binocular photo tube, carry out the following two steps:
 - Align the crossline micrometer 14:140 or the eyepiece reticle to the vibration direction of the polarizer using the *adjustment aid* [▶ 89].
 - Remove the Pol adjustment aid.
 6. Move a selected crystal to the center of the reticle. Only crystals above a defined size can be observed.
 7. Swivel in the front lens on the condenser, if necessary.
 8. For conoscopy of small crystals, close the luminous-field diaphragm, if necessary, to prevent the axial figure of the examined crystal from being superimposed by the axial figures of adjacent crystals.
 9. Swivel the 40x or 50x objective into the light path.
 10. Focus the sample.
 11. Remove an eyepiece from the tube to view the axial figure in the eyepiece tube.
 12. For an improved assessment of the axial figure, insert a diopter or an auxiliary microscope (if available) in the eyepiece tube.

6.4.8.5.2 Conoscopy with Bertrand System Module

- Prerequisite**
- ✓ Strain-free objectives are installed in the *nosepiece* [▶ 67].
N-Achroplan 50x/0.9 Pol objective or EC Plan-Neofluar 40x/0.9 Pol objective
 - ✓ The Pol rotary stage is *installed* [▶ 155].
 - ✓ Pol binocular photo tube is installed or eyepiece with crossline micrometer 14:140 and adjustment aid for polarization microscopy are available.
 - ✓ The achromatic-aplanatic 0.9 H Pol condenser or 0.9 Pol condenser is installed.
 - ✓ The Bertrand system module is inserted in reflector turret.
 - ✓ The D polarizer (rotatable or fixed) is installed.
 - ✓ Analyzer slider or D Pol analyzer module in the reflector turret or reflector slider are available.
 - ✓ The microscope is adjusted for *transmitted light brightfield microscopy* [▶ 78].
- Procedure**
1. Place the sample on the stage.
 2. Focus the sample.
 3. Swivel the polarizer.
 4. If you do not use the Pol binocular photo tube, carry out the following two steps:
 - Align the crossline micrometer 14:140 or the eyepiece reticle to the vibration direction of the polarizer using the *adjustment aid* [▶ 89].
 - Remove the Pol adjustment aid.
 5. Move a selected crystal to the center of the reticle.
 6. Swivel in the front lens on the condenser, if necessary.
 7. Swivel the 40x or 50x objective into the light path.
 8. Focus the sample.
 9. Close the luminous-field diaphragm as much as is necessary to prevent the axial figure from being superimposed by the axial figures of adjacent crystals.
 - The smallest crystal extension that can be masked out is 4 µm.
 10. Swivel in the Pol Bertrand system module on the reflector turret.
 - The axial figure appears in the field of view.

Info

In the case of uniaxial crystals, the most favorable orientation for conoscopic viewing is obtained with those sample features (e.g. of a thin section) that in orthoscopic viewing change the brightness as little as possible upon rotating the stage. In this case, the direction of viewing and the optical axis are nearly parallel. The same refers also to biaxial crystals, if they are viewed along or approximately in the direction of one of the two optical axes.

6.4.8.5.3 Conoscopy with Intermediate Plate and Bertrand Lens Slider

- Prerequisite**
- ✓ Strain-free objectives are installed in the *nosepiece* [▶ 67].
EC Plan-Neofluar 40x/0.9 Pol objective or EC Plan-Neofluar 100x/1.30 Oil Pol objective or EC Epiplan-Neofluar 50x/0.8 Pol objective or EC Epiplan-Neofluar 100x/0.9 Pol objective
 - ✓ The Pol rotary stage is *installed* [▶ 155].
 - ✓ Pol binocular photo tube is installed or eyepiece with crossline micrometer 14:140 and adjustment aid for polarization microscopy are available.
 - ✓ The achromatic-aplanatic 0.9 H Pol condenser or 0.9 Pol condenser is installed.
 - ✓ Bertrand lens slider inserted in the intermediate plate.
 - ✓ The D polarizer (rotatable or fixed) is installed.
 - ✓ The D Pol analyzer module in the reflector turret or reflector slider are available.
 - ✓ The microscope is adjusted for *transmitted light brightfield microscopy* [▶ 78].

- Procedure**
1. Place the sample on the stage.
 2. Focus the sample.
 3. Swivel the polarizer.
 4. Swivel the D Pol analyzer module into the light path.
 5. If you do not use the Pol binocular photo tube, carry out the following two steps:
 - Align the crossline micrometer 14:140 or the eyepiece reticle to the vibration direction of the polarizer using the *adjustment aid* [▶ 89].
 - Remove the Pol adjustment aid.
 6. Move a selected crystal to the center of the reticle.
 7. Swivel in the front lens on the condenser, if necessary.
 8. Swivel the recommended objective into the light path.
 9. Focus the sample.
 10. Close the luminous-field diaphragm as much as is necessary to prevent the axial figure from being superimposed by the axial figures of adjacent crystals.
 - The smallest crystal extension that can be masked out is 4 µm.
 11. Push the Bertrand lens slider incorporated in the intermediate plate into its active position.
 - The axial figure appears in the field of view.
 12. Focus the axial figure by shifting the lever of the Bertrand lens slider.

6.5 Setting Up for Reflected Light Techniques

6.5.1 Setting Up for Reflected Light Brightfield Microscopy Using the KÖHLER Method

For more information about the method, see chapter *Reflected Light Brightfield Contrast Using the KÖHLER Method* [▶ 60].

- Prerequisite**
- ✓ A reflected light light source is *installed* [▶ 72].
 - ✓ In the reflector turret, an ACR P&C brightfield reflector module for reflected light is installed.
 - ✓ The microscope is operational for reflected light microscopy.
 - ✓ The microscope is *adapted* [▶ 74] to the user.

- Procedure**
1. If required, push the **RL** button for reflected light illumination.

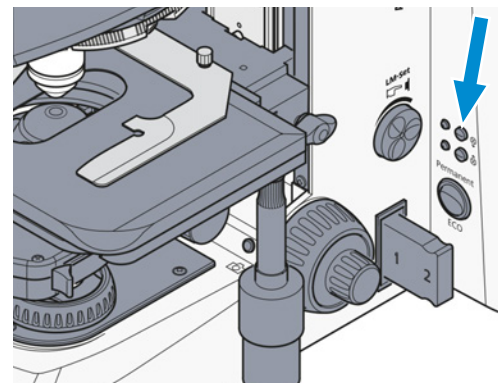

- Adjust the image brightness using the **Intensity/LM** knob on the microscope stand.

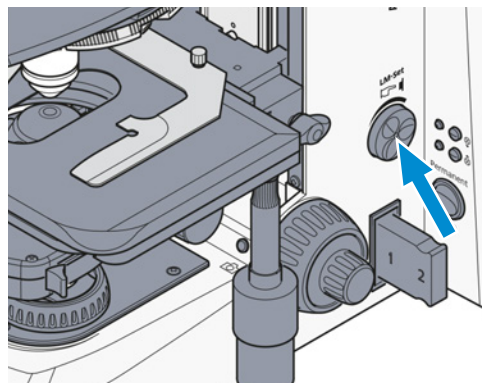

- If required, move the toggle switch on the external power supply unit to the RL position for reflected light and use the **Intensity/LM** knob to adjust the light intensity.
- Place a high-contrast reflected light sample into the sample holder of the mechanical stage.
- Swivel the 10x objective into the beam path.

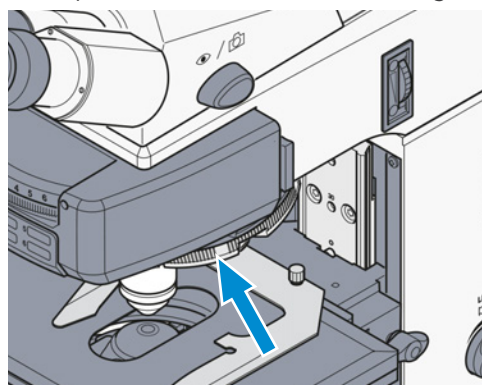

- Focus the sample.
Try to focus away from the sample to avoid any collision between the objective and sample.

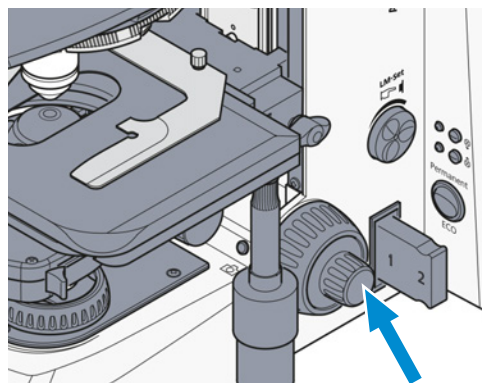

- Turn the knurled button of the aperture diaphragm to a medium position.

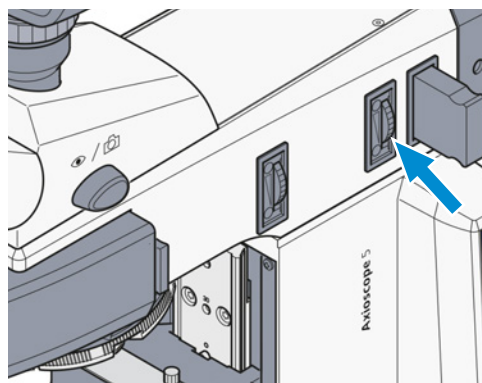

8. Adjust the knurled knob on the field diaphragm so that the field diaphragm becomes visible in the field of view **A**.

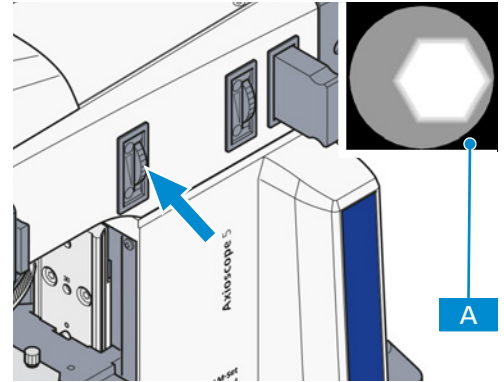

9. Use the focus drive to readjust the focus on the edge of the field diaphragm **B**.

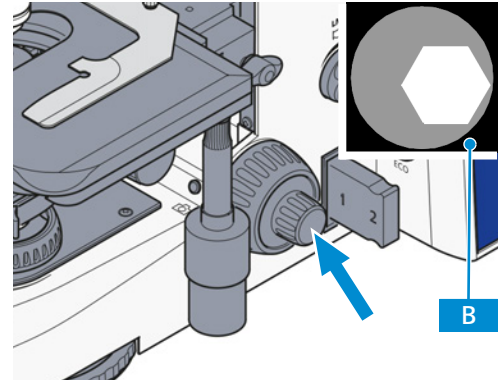

10. Use the centering screws to center the field diaphragm on the edge of the field of view **C**.

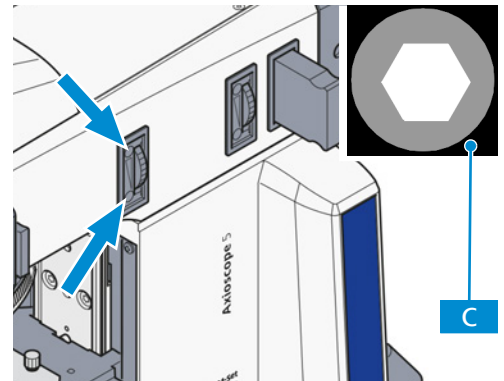

11. Open the field diaphragm enough to make the edge of the diaphragm disappear from the field of view **D**.

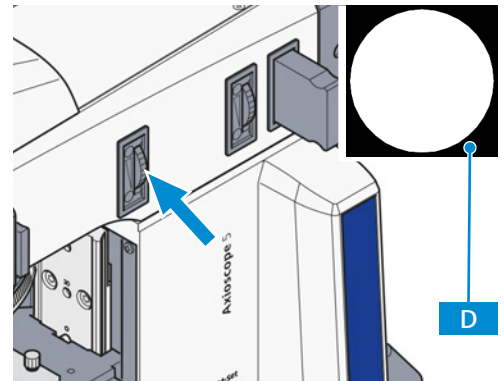

12. Remove one eyepiece from the tube.

13. Looking through the tube, adjust the aperture with the adjusting lever of the aperture diaphragm to the size of approx. $2/3$ - $4/5$ of the diameter of the objective exit pupil **E**. In most cases this aperture gives the best contrast at almost full resolution and is thus the best compromise for the human eye.

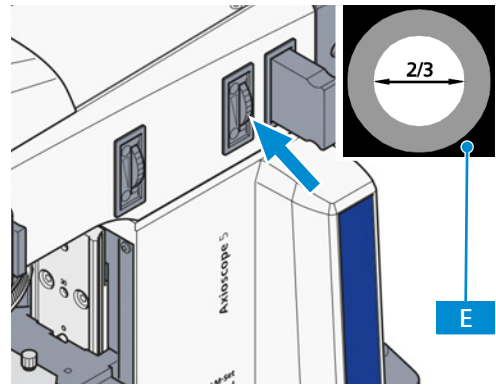

14. Replace the eyepiece.
 15. Re-adjust the focus using the coarse and fine focusing drives and set the image brightness according to the reflected light sample.
 16. Readjust the aperture stop diameter after each objective change.

Info

Never use the aperture diaphragm for controlling image brightness. Use the **Intensity/LM** knob for illumination intensity!

6.5.2 Setting Up for Reflected Light Darkfield Microscopy Using the KÖHLER Method

For more information about the method, see chapter *Reflected Light Brightfield Contrast Using the KÖHLER Method* [▶ 60].

- Prerequisite**
- ✓ A reflected light light source is *installed* [▶ 72].
 - ✓ In the reflector turret, an ACR P&C reflector module for reflected light is installed.
 - ✓ A suitable objective for RL darkfield microscopy is *installed* [▶ 67], e.g. Epiplan-Neofluar HD, EC Epiplan-Neofluar HD, Epiplan HD.
 - ✓ The microscope is operational.
 - ✓ The illumination is adjusted for *reflected light brightfield microscopy* [▶ 93]. The field diaphragm image should lie just barely outside of the edge of the field of view to avoid reflections.

- Procedure**
1. Swing the darkfield ACR P&C reflector module for reflected light on the reflector turret into the beam path.

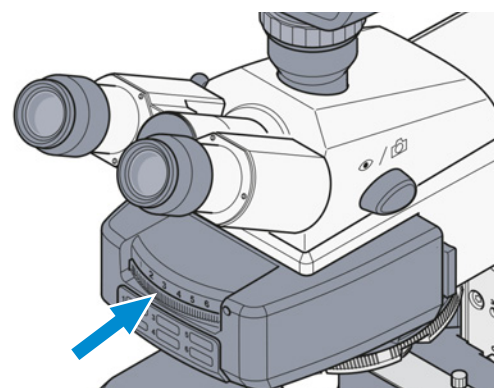

2. Remove the 6x20 mm compensator slider if inserted.

- Swivel the objective position with the darkfield HD objective into the beam path.

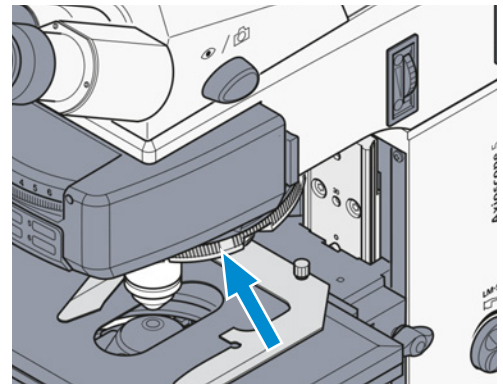

- Completely open the aperture diaphragm **A**.

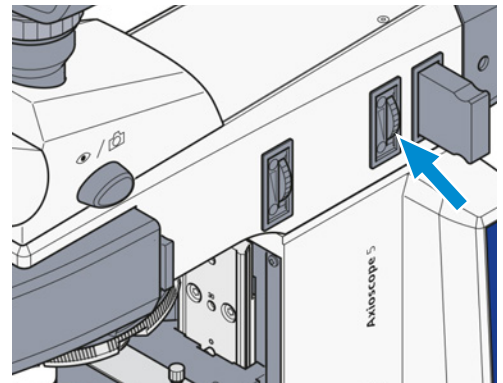

- Switch off or remove neutral filters if applicable.
- Place the sample on the stage.
- Focus the sample.

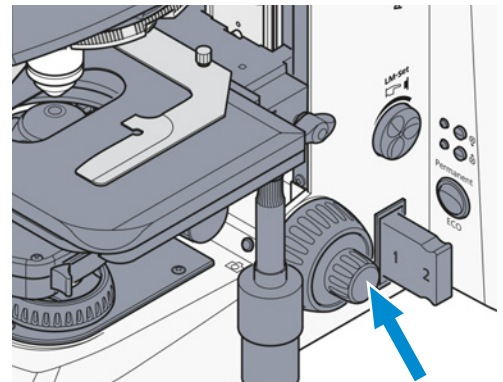

↳ The illumination is now adjusted for darkfield microscopy.

6.5.3 Setting Up for Reflected Light DIC Microscopy

For more information about the method, see chapter *Reflected Light DIC and C-DIC Contrast* [[▶ 60](#)].

- Prerequisite**
- ✓ A reflected light light source is *installed* [[▶ 72](#)].
 - ✓ The mechanical stage, 75x50/240° rotatable or the rotary stage Pol is *installed* [[▶ 69](#)].
 - ✓ The microscope is operational.
 - ✓ DIC reflector module is installed.
 - ✓ A suitable objective for DIC is *installed* [[▶ 67](#)], e.g. EC Epiplan-Neofluar, Epiplan with the additional label "DIC" or "Pol".
 - ✓ DIC slider compatible with the objectives in use, is available.
 - ✓ The illumination is adjusted for *reflected light brightfield microscopy* [[▶ 93](#)].

Procedure 1. Swivel the DIC module on the reflector turret into the beam path.

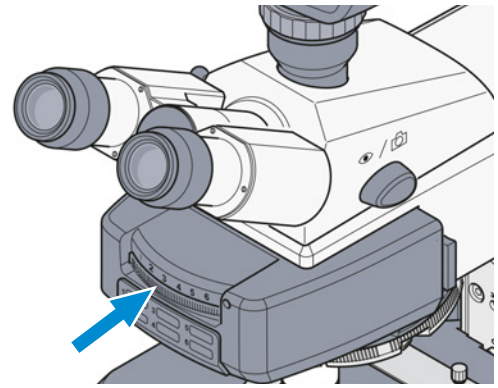

2. Swivel the DIC compatible objective into the beam path.

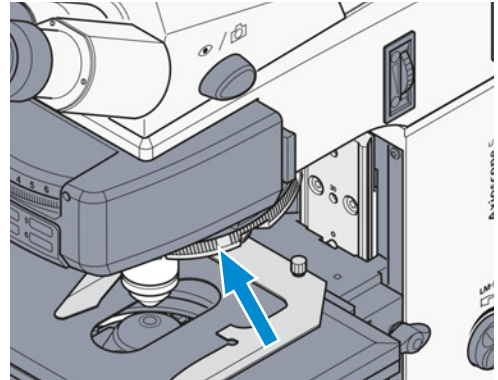

3. Slide the according DIC slider **1** into the slot of the nosepiece.

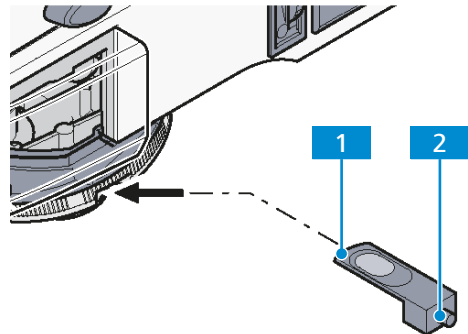

4. Place the sample on the stage.

5. Focus the sample.

6. Turn the mechanical stage so the structure of interest is visible with maximum contrast.

7. Use the knurled screw **2** on the DIC slider to adjust the optimal contrast.

6.5.4 Setting Up for Reflected Light C-DIC Microscopy

For more information about the method, see chapter *Reflected Light DIC and C-DIC Contrast* [▶ 60].

- Prerequisite**
- ✓ A reflected light light source is *installed* [▶ 72].
 - ✓ The microscope is operational.
 - ✓ C-DIC reflector module is installed.
 - ✓ A suitable objective for DIC is *installed* [▶ 67], e.g. EC Epiplan-Neofluar, Epiplan with the additional label "DIC" or "Pol".
 - ✓ C-DIC slider compatible with the objectives in use, is available.
 - ✓ The illumination is adjusted for *reflected light brightfield microscopy* [▶ 93].

Procedure 1. Swivel the C-DIC module on the reflector turret into the beam path.

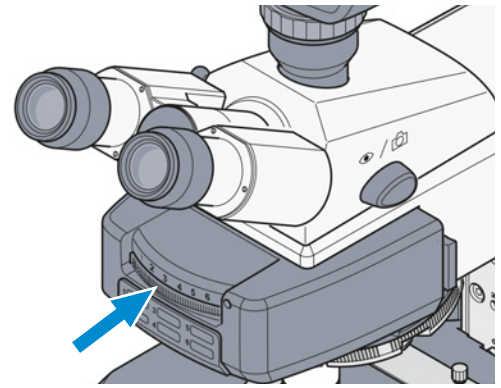

2. Swivel the DIC compatible objective into the beam path.

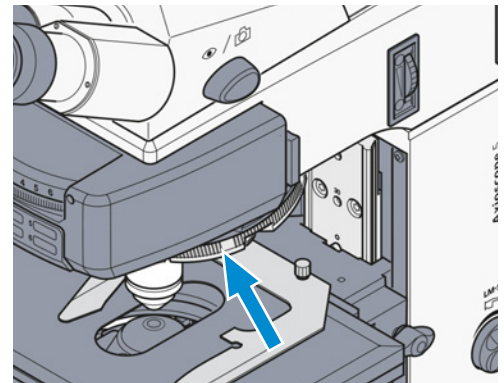

3. Slide the C-DIC slider **1** into the 6x20 mm compensator slot.

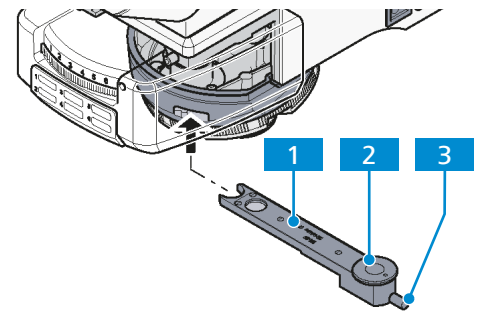

4. Place the sample on the stage.

5. Focus the sample.

6. Turn the setting wheel **2** on the C-DIC slider so the structure of interest is visible with maximum contrast.

→ No further stage rotation is necessary.

7. Optimized the contrast by adjusting the setting screw **3**.

6.5.5 Setting Up for Reflected Light TIC Microscopy

For more information about the method, see chapter *Reflected Light TIC Contrast* [▶ 60].

- Prerequisite**
- ✓ The HAL 100 light source is *installed* [▶ 72].
 - ✓ The microscope is operational.
 - ✓ A suitable objective for DIC is *installed* [▶ 67], e.g. EC Epiplan-Neofluar, Epiplan with the additional label "DIC" or "Pol".
 - ✓ TIC slider 6x20 mm with the appropriate C-DIC reflector module is available.
 - ✓ The illumination is adjusted for *reflected light brightfield microscopy* [▶ 93].

- Procedure**
1. Place the sample on the stage.
 2. Focus the sample.
 3. Swivel the C-DIC module on the reflector turret into the beam path.

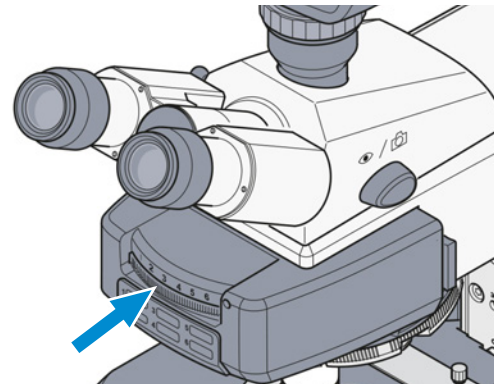

4. Swivel the DIC compatible objective into the beam path.

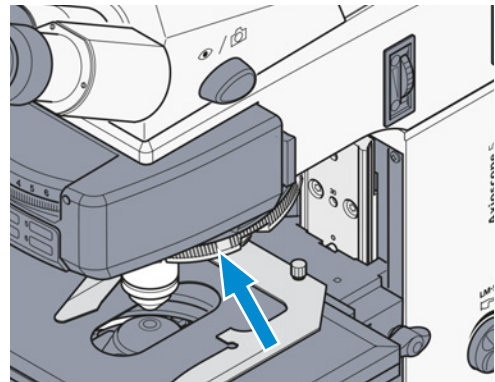

5. Slide the TIC slider **1** into the 6x20 mm compensator slot.

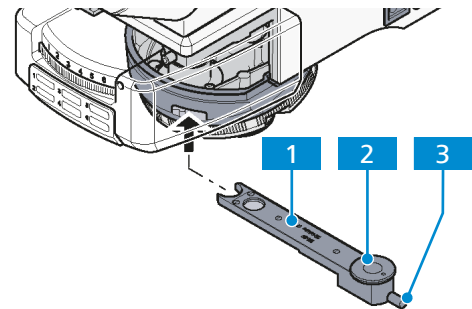

→ Chromatic interference stripes appear in the field of view.

6. Move the black interference stripe by sight to the middle of the field of view. Use the setting screw **3**.
7. To choose the structure to be measured, turn the setting wheel **2** on the TIC slider until the interference stripes are vertical to the direction in which the sample is broken down.

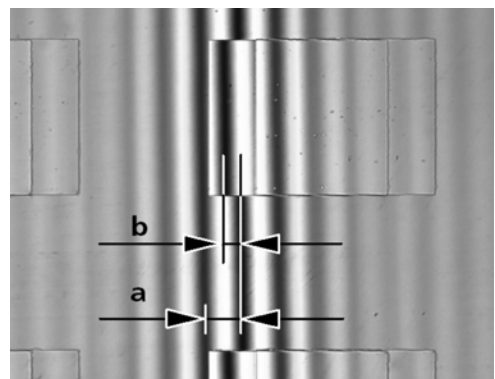

8. Determine the values for a (distance between the interference stripes) and b (offset of the interference stripes along the step) in the interference image. Use an eyepiece reticle micrometer or a micrometer eyepiece.

6.5.6 Setting Up for Reflected Light Polarization Microscopy – Proof of Bireflectance and Reflection

The present section applies to the following microscope type:

- Axioscope 5 TL/RL Pol (430035-9291-000)

For more information about the method, see chapter *Reflected Light Polarization Contrast* [▶ 63].

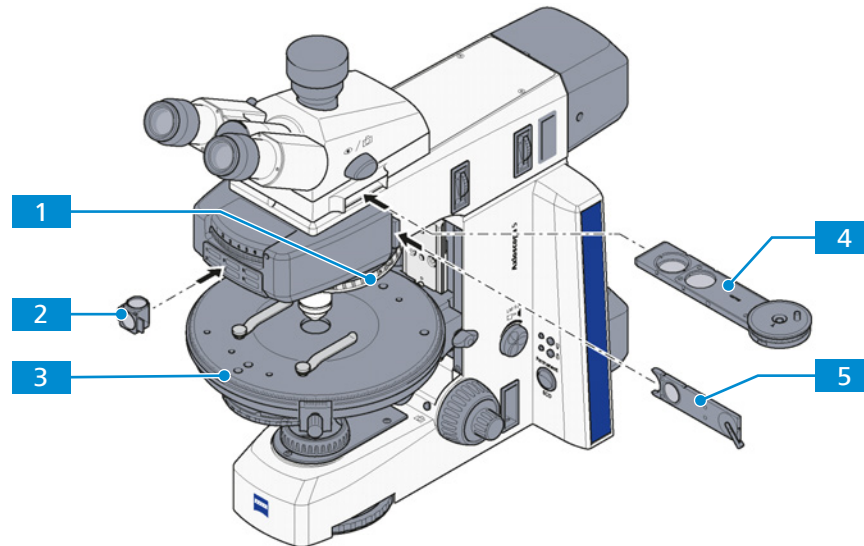

- Prerequisite**
- ✓ A reflected light light source is *installed* [▶ 72].
 - ✓ The rotary stage Pol is *installed* [▶ 69].
 - ✓ The microscope is operational.
 - ✓ The DIC reflector module or the DIC Rot I P&C reflector module is installed or the Pol P&C reflector module plus analyzer slider are available or analyzer slider plus polarizer slider are available.
 - ✓ A suitable objective for Pol is *installed* [▶ 67], e.g. Epiplan-Neofluar Pol, EC Epiplan-Neofluar Pol, Epiplan Pol.
 - ✓ The illumination is adjusted for *reflected light brightfield microscopy* [▶ 93].

- Procedure**
1. If using the objective position with a DIC position, remove the DIC slider, if necessary.
 2. Swivel the Pol objective **1** into the beam path.
 3. Swing the DIC P&C reflector module **2** or the Pol P&C reflector module into the beam path. Slide the analyzer slider **4** into the compartment.
 4. Alternatively, slide the analyzer slider **4** and the polarizer slider **5** into their compartments, if applicable.
 5. Place the sample on the rotary stage Pol **3**.
 6. Swivel in the objective with the desired magnification.
 7. Focus the sample.
 8. Turn the rotary stage Pol to examine the sample in the polarization contrast.
 - The sample appears in polarization contrast while turning the stage.
- ↳ A sample is bireflectant when the sample details show differences in brightness and color which change when the stage rotates. For samples with low bireflectance we recommend using the analyzer with a rotatable lambda plate.
- ↳ Pleochroism is present when the color of the sample changes as soon as the stage rotates (overhead polarizer is turned on, analyzer is turned off).

6.5.7 Setting Up for Reflected Light Fluorescence Microscopy

The present section applies to the following microscope types:

- Axioscope 5 TL/FL (430035-9061-000)
- Axioscope 7 TL/FL (430035-9320-000)

For more information about the method, see chapter *Reflected Light Fluorescence Contrast* [▶ 63].

⚠ WARNING

Skin or eye injury due to hazardous light emission

The light source belongs to Risk Group 3 as specified in IEC 62471 and emits LED radiation and UV radiation. Skin or eye injury can result from the exposure.

- ▶ Avoid any eye and skin exposure to the light-emitting aperture of the light source.
- ▶ Avoid exposure of skin to the radiation. Use suitable protective equipment/protective clothing if required.
- ▶ Before installing or removing the light source always make sure it is switched off.

NOTICE

Property damage due to heat emission

Microscope lamps emit a lot of heat which could damage the heat-sensitive fluorescence filters.

- ▶ Do not remove the heat protection filter when using a fluorescence filter.

Info

The adjustment of reflected light fluorescence is facilitated by starting with an objective of average magnification, e.g. EC Plan-Neofluar 20x/0.50, and a sample of high fluorescence. Demonstration samples can also be used for the start-up.

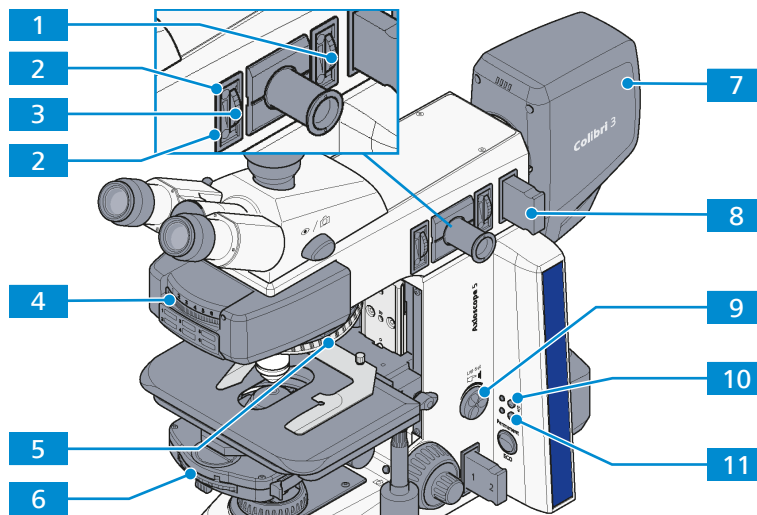

- Prerequisite**
- ✓ If used, the mercury vapor short arc lamp of the HBO 100 light source is *adjusted* [▶ 143].
 - ✓ In the reflector turret, FL P&C reflector modules equipped with respective filter sets are installed.
 - ✓ Fluorescence protection shield is available.
 - ✓ A suitable objective for fluorescence microscopy is installed.
e.g. EC Plan-Neofluar or Fluor (UV excitation)
 - ✓ The microscope is operational.
 - ✓ The microscope is adjusted for *reflected light brightfield microscopy* [▶ 93].
- Procedure**
1. If necessary, remove the compensator from the 6x20 mm slot above the nosepiece.
 2. Slide the fluorescence protection shield into the 6x20 mm slot.
 3. Swivel in the EC Plan-Neofluar objective on the nosepiece **5**.
 4. Initially set transmitted light illumination by pushing the **TL** button **11**.
 5. If necessary, turn the condenser turret **6** to the **H** (B) position for transmitted light brightfield (or phase contrast if using a Ph objective).
 6. Seek the sample detail to be examined.
 7. Keep the light path in the reflected light light source blocked via the blocking position of the filter slider for reflected light.
 8. Switch on the Colibri 3 light source **7** by pushing the **RL** button **10**.
 9. Press the **Intensity/LM** button **9** briefly for less than 1.5 seconds repeatedly to activate the required LED module or all LED modules of Colibri 3 together.
 - The indicator light of the respective LED module on the Colibri 3 lights up when this module is switched on.
 10. If using the HBO 100 light source, switch on the external power supply and let it warm up to operational temperature for about 15 minutes.
 11. Swivel it in the FL P&C reflector module **4** with the desired fluorescence filter combination (depending on the excitation mode).
 12. Unblock the light path in the reflected light light source with the filter slider for reflected light **8**.
 13. If necessary, adjust the FL attenuator to 100% transmission in order to facilitate locating fluorescence signals.
 - Reduce the transmission later to preserve the sample.
 14. Remove an eyepiece from the tube and adjust the aperture diaphragm **1** by sight.
 15. Open the aperture diaphragm enough to see the whole objective exit pupil.
 16. Replace the eyepiece in the tube.
 17. Close the field diaphragm **3** enough to make it visible in the field of view.
 18. Using both centering screws **2**, center the field diaphragm on the edge of the field of view.
 19. Open the field diaphragm enough to make it just disappear behind the edge of the field of view, or, if you are using a sample which might bleach out, reduce the field diaphragm for the field of view.
 20. Focus the sample again.
 21. If using the HBO 100 light source, optimize the collector position of the HBO 100 using the knurled knob.
 - Adjust the collector so that the reflector module of the short-wave excitation illuminates the field of view evenly.
 - A correction of the collector position is not necessary in modules with longer-wave excitation.
- ↳ The illumination is now adjusted for fluorescence microscopy.

6.6 Parfocality Function

Using the parfocality function as described here requires a firmware version 01.097 or higher. For questions how to identify the firmware version and how to update it, contact a ZEISS service representative.

6.6.1 Enabling/Disabling Parfocality

By factory default, the parfocality function is enabled.

- Procedure**
1. Press the **Stage control** button (left side) and the **Intensity/LM** knob simultaneously for at least 1.5 seconds to switch between enabled and disabled parfocality function.
 - Parfocality function disabled: The indicator light blinks ORANGE twice.
 - Parfocality function enabled: The indicator light blinks GREEN twice.

6.6.2 Using Parfocality

- Prerequisite**
- ✓ The parfocality function is *enabled* [▶ 104] and *calibrated* [▶ 104].
 - ✓ A sample is placed on the stage.

- Procedure**
1. Use the objective with the highest magnification to focus on the sample.
 - ↳ As long as the focus settings are not changed, the sample will stay in focus with all objectives. Parfocality will only work for **all** objectives if the objective with the **highest** magnification was used for focussing.

6.6.3 Calibrating Parfocality

Axioscope 7 is calibrated by a ZEISS service representative upon installation. The microscope's parfocality function does not need to be recalibrated except for the following situations:

- Any objective change from the nosepiece, e.g., adding a new objective, replacing one objective, removing one objective.
- The system is moved horizontally or vertically, e.g., moving the system from one lab to another, moving the system from one bench to another in the same lab.
- Stand main board replacement or firmware upgrade.

- Prerequisite**
- ✓ A flat sample is placed on the stage.

- Procedure**
1. Press the **Stage control** button (left side) for at least 8 seconds to *start the calibration process* [▶ 41].
 - The indicator light lights RED.
 2. Swivel in the dry objective with the highest magnification.
 3. Focus on the sample.
 4. Press the **Stage control** button for less than 1 second to save the focus position for this objective.
 - The indicator light blinks GREEN twice.
 5. Swivel in all other objectives one by one and repeat steps 3 and 4 for each objective.
 6. Press the **Stage control** button for at least 8 seconds to *finish the calibration process* [▶ 41].
 - The indicator light lights GREEN.

6.7 Switching Off the Microscope

Procedure 1. Switch the microscope off using the power switch **On/Off**.

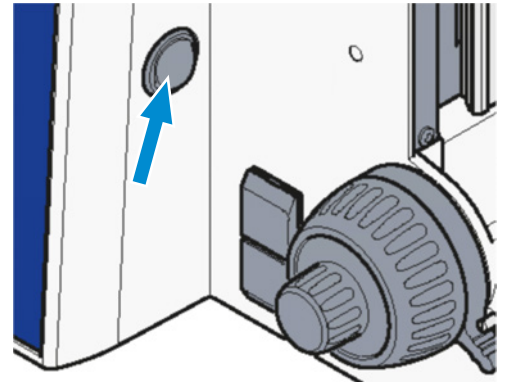

2. Cover the microscope with the dust cover.

7 Care and Maintenance

To ensure the best possible performance of the microscope and its components, maintenance must be performed on a regular basis. Keep the service logs of the microscope.

To maintain operational safety and reliability of the microscope, we recommend entering into a **ZEISS Protect Service Agreement**.

Info

For additional information and detailed descriptions, refer to further applicable documents or ask your ZEISS Sales & Service Partner.

Info

Contact the ZEISS service representative to learn more about the **ZEISS Predictive Service**.

7.1 Safety during Cleaning and Maintenance

Only conduct preventive measures described here. All tasks of maintenance and cleaning not described may only be performed by an authorized ZEISS service representative.

Any unauthorized intervention or any operation outside the scope of the intended use can lead to injuries and property damage and voids all rights to warranty claims. Only original spare parts from ZEISS may be used.

DANGER

Electric injury due to live parts

Coming in contact with live parts can lead to electric shock or burn.

Prior to opening and cleaning:

- ▶ Pull the power plug for safe disconnection from the power supply.

NOTICE

Functional impairment due to dirt, dust and moisture

Dirt, dust, and moisture can impair the microscope and its components functionality and can cause short-circuits. Blocking or covering ventilation slots can lead to a build-up of heat that can damage the device and, in extreme cases, cause a fire.

- ▶ Use the dust protection cover if the microscope is not used.
- ▶ The ventilation slots must be unobstructed at all times and the heat sink (if available) must be unobstructed.
- ▶ Do not insert any objects or allow them to fall into the ventilation slots.
- ▶ Perform regular maintenance and cleaning according to the instructions in this document and according to the instructions in the applicable documents.
- ▶ Make sure that no cleaning liquid or moisture gets inside the microscope and its components.
- ▶ In case of damage, the affected parts of the microscope must be taken out of operation.

7.2 Maintenance Schedule

To maintain best possible performance of the microscope, it is essential to perform preventive maintenance on a regular basis. The recommended intervals depend on the total uptime of the microscope.

Interval	Part/Component	Activity
daily	Microscope	Check the power cable and the plug for possible damage. If any damage is observed, turn the instrument off and secure it against inadvertent restarts immediately. Call in a qualified professional to remedy the problem.
If LED modules are defective or used up.	Colibri 3 light source	Replace the LED modules.
If the travel range in X direction will gradually become smaller	Mechanical stage	<i>Recovering the stage travel range. [▶ 110]</i>

Tab. 3: Maintenance Plan

7.3 Maintenance Work

Repairs of mechanical, optical or electronic components inside the microscope and electrical components may be performed only by an authorized ZEISS service representative or specially authorized personnel.

To ensure optimal configuration and trouble-free function of your microscope over a longer period of time, we recommend that you enter into a service/maintenance agreement with ZEISS. For subsequent orders or when service is required, please get in touch with your local ZEISS service representative.

7.3.1 Cleaning an Optical Surface

NOTICE

Damage of optical surfaces due to improper cleaning

- ▶ Remove dust from the optical surface slowly and carefully.
- ▶ Remove dust on optical surfaces with a natural-hair brush or blow it off with a dust blower.
- ▶ Avoid touching optical surfaces with fingers.
- ▶ Never use abrasive compounds or cleaners.

- Parts and Tools**
- 🔧 Clean cloth
 - 🔧 Cotton swab
 - 🔧 Distilled water
 - 🔧 Optical cleaning solution (70 % ethanol)
 - 🔧 Lint-free cloth

- Procedure**
1. Moisten a cotton swab or a clean cloth with distilled water or, if necessary, with an optical cleaning solution.
 2. Wipe optical surfaces in a circular motion towards the edge of the optics with slight pressure.

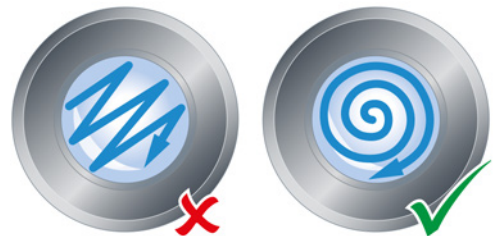

3. Dry with a lint-free cloth.

7.3.2 Removing Water-Soluble Contamination

- Parts and Tools**
- 🔧 Clean cloth
 - 🔧 Lint-free cloth

- Prerequisite** ✓ The microscope and its components are switched off and disconnected from the power supply.

- Procedure**
1. Remove dust and loose dirt particles with a soft brush or clean lint-free cloth.
 2. If necessary, moisten a clean cloth with water. **Info** A mild detergent (no solvent!) may be added to the water for stubborn dirt.
 3. Wipe off the area with the moistened cloth. **Info** Labels on the device may only be cleaned using a dry cloth.
 4. Dry with a lint-free cloth.

7.3.3 Exchanging the 12 V, 50 W Halogen lamp of the HAL 50 Halogen Illuminator

⚠ CAUTION

Burning hazard due to hot light sources

Light sources can become hot during processing.

- ▶ Avoid touching the hot light source housing.
- ▶ Let the light source cool down before touching it.

- Prerequisite**
- ✓ The microscope is switched off.
 - ✓ The light source has cooled down for about 15 minutes.

- Procedure**
1. Remove the HAL 50 halogen light source **2** from the back of the stand **1**.

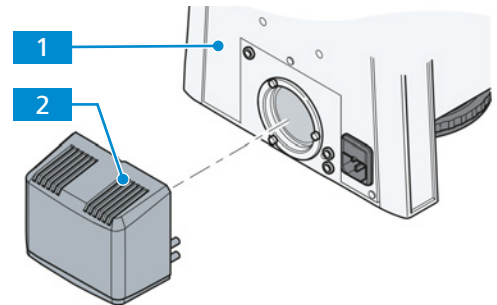

2. Put it down with the open side facing up.
3. Remove the used lamp **3** in upward direction.

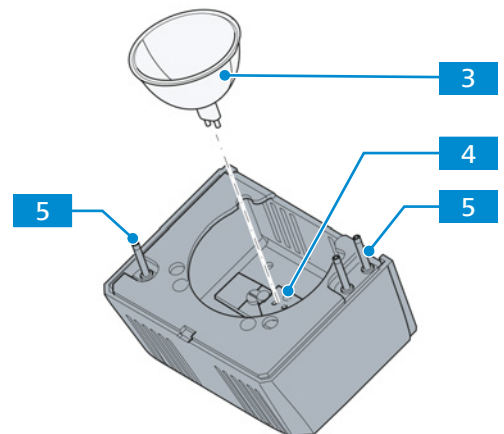

4. Push the new lamp with its two cap pins gently and carefully into the socket **4** of the HAL 50 halogen light source. Do not bend the cap pins.
5. Place the HAL 50 halogen light source with the connecting pins **5** into the back side of the microscope and push until the lamp engages securely.

7.3.4 Recovering the Stage Travel Range in X-Axis

After long hours of use, the X direction range will gradually become smaller. This is not a quality issue and can be easily reset.

- Procedure**
1. Hold the sample holder's two screws **1** / **2**.

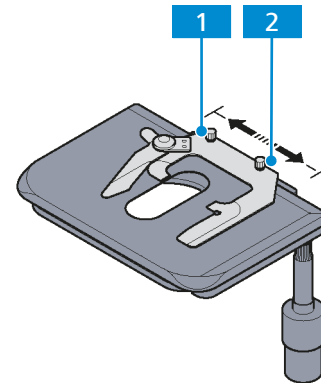

2. Move the stage to the left until it hits the end stop.
3. Move the stage to the right until it hits the end stop.

7.3.5 Exchanging the Fuses T 15A H 250V in the Stand

⚠ DANGER

Electric injury due to live parts

When the microscope and its components are still switched on, coming in contact with live parts can lead to electric shock or burn.

- ▶ Switch off the microscope and its components prior to opening or cleaning.
- ▶ Disconnect the microscope and its components from the mains.

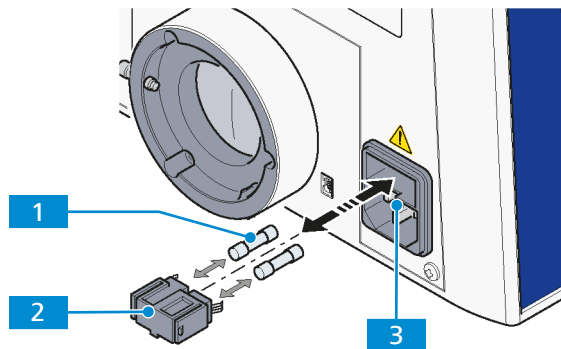

Parts and Tools 🔧 2x Fuse type T 15A H 250V

Prerequisite ✓ The microscope is switched off and disconnected from the mains.

- Procedure**
1. If the fuses fail, first check the cause and remedy technical problems properly.
 2. Remove the fuse holder **2** on the rear side of the stand.
 3. Remove fuses **1** from the fuse holder.
 4. Insert new fuses.
 5. Push the fuse holder back into the fuse compartment **3** until it locks in place.
 6. Bring the microscope back into operation.

8 Troubleshooting

The following table provides information about solving common problems.

Info

If you cannot solve the problem or if you are unsure about a certain technical difficulty, contact your local ZEISS service representative.

Symptom	Cause	Measure
No illumination light after switching on the microscope.	Nosepiece and/or reflector turret are not engaged to defined positions.	Move the nosepiece and/or reflector turret to the left or right to engage the nosepiece and/or reflector turret to defined positions. Then restart the microscope.
Shading or brightness irregularities in the field of view of the microscope; the field of view is not fully visible.	The vis/phot push-pull rod/shift knob on the photo tube is not in correct functional position (in-between position)	Move the vis/phot push-pull rod/shift knob to the correct functional position (end position).
	Nosepiece with objective is not fully engaged in its locking position.	Engage the nosepiece with the objective in its locking position.
	Condenser is not adjusted correctly.	Adjust the condenser correctly (adjustment, centering), see <i>Setting Up for Transmitted Light Brightfield Microscopy Using the KÖHLER Method</i> [▶ 78].
	Aperture diaphragm is not adjusted correctly.	Adjust the aperture diaphragm correctly (centering, opening), see <i>Setting Up for Transmitted Light Brightfield Microscopy Using the KÖHLER Method</i> [▶ 78].
	Field diaphragm is not adjusted correctly.	Adjust the field diaphragm correctly (centering, opening), see <i>Setting Up for Transmitted Light Brightfield Microscopy Using the KÖHLER Method</i> [▶ 78].
	Filter is not correctly inserted in its slot.	Insert the filter correctly.
Low resolution and poor contrast.	Opening of the aperture diaphragm is not adjusted correctly.	Adjust the opening of the aperture diaphragm according to the 2/3-rule and the texture of the sample you are using, see <i>Setting Up for Transmitted Light Brightfield Microscopy Using the KÖHLER Method</i> [▶ 78].

Symptom	Cause	Measure
	Condenser is not focused correctly and front lens is not connected correctly.	Focus the condenser and turn the front lens correctly on or off, see <i>Setting Up for Transmitted Light Brightfield Microscopy Using the KÖHLER Method</i> [▶ 78].
	Wrong thickness of the frame glass when using a transmitted light objective with a frame glass thickness correction of 0.17 mm.	Use standardized frame glasses with a thickness of 0.17 mm.
	Specimen holder is not inserted correctly.	Turn the sample holder over, the sample side shows up.
	No immersion oil or an unspecified immersion oil is used with immersion objectives.	Use immersion oil 518 N or 518 F by ZEISS.
	Air bubbles in the immersion oil.	Repeat the oiling procedure with fresh oil.
	Immersion oil on the front lens of a dry objective.	Clean the lens.
	Correction setting is not set to the proper thickness of the frame glass.	Adjust the correction setting to the correct thickness of the frame glass.
	Dirt or dust on the optical surfaces of objectives, eyepieces, condensers or filters.	Clean the soiled optical component.
Parfocal performance not good on Axioscope 7	The focal plane was adjusted using the low-magnification objective which has a larger depth of focus than the high-magnification objective.	Determine the focal plane using the high-magnification objective.
	There is a backlash of Z-axis drive.	Adjust the focal plane from the same direction for all the objectives.
No light in eyepiece	The system is in ECO mode.	Turn the Intensity/LM knob clockwise to wake up the system.
	The light intensity is too low.	Turn the Intensity/LM knob clockwise to increase the light.
	The light was turned off by another pressing of the respective RL/TL button.	Press the RL or TL button according to the corresponding indicator in green color.
	LED connector is loose (when using builtin LED10 illumination).	Unmount the LED10 lamp case from the microscope stand, unplug and reinsert the connector to the socket. Check again.

Symptom	Cause	Measure
	The reflector module is incorrectly installed or absent.	Check the reflect turret and make sure the correct reflector is in use.
	The field diaphragm is closed.	Check and, if necessary, open the field diaphragm.
XY stage stops at wrong position after initialization on Axioscope 7	The XY stage initialization failed.	Restart the microscope, if the issue still exists please contact ZEISS Service.
Cannot focus on the sample under high-magnification nosepiece with Axioscope 7	The Z-axis resolution was not configured with the magnification of nosepiece.	Configure the system with correct nosepiece information with MTB Configuration.
Asymmetric image sharpness, e.g. one side is sharp, one side is blurred.	Condenser is not adjusted properly.	Re-adjust the condenser, see <i>Setting Up for Transmitted Light Brightfield Microscopy Using the KÖHLER Method</i> [▶ 78].
	Nosepiece is not engaged in its locking position.	Engage the nosepiece in its locking position (click-diaphragm).
	Sample is not fixed correctly on the mechanical stage.	Insert and fix the sample correctly in the sample holder.
Distinct focus differences when changing the objective.	Focusable eyepieces are not adjusted correctly.	Adjust the focusable eyepieces according to the user's vision defect, see <i>Focusing when Using Eyepiece Reticles</i> [▶ 74].
	Objective is not screwed in all the way.	Screw the objective in to the stop.
	Tube lens is not mounted, or it is mounted unnecessarily.	Mount the tube lens or remove it, according to the situation.
The left and the right field of view cannot be brought together in one image.	Distance of the eyepiece (distance of the pupils) is not adjusted correctly.	Re-adjust the distance of the eyepiece, see <i>Adjusting the Position of the Eyepieces</i> [▶ 74].
	Focusable eyepieces are not adjusted correctly.	Adjust the focusable eyepieces according to the user's vision defect, see <i>Focusing when Using Eyepiece Reticles</i> [▶ 74].
Using the microscope fatigues the eyes.	Distance of the eyepiece (distance of the pupils) is not adjusted correctly.	Re-adjust the distance of the eyepiece, see <i>Adjusting the Position of the Eyepieces</i> [▶ 74].
	Focusable eyepieces are not adjusted correctly.	Adjust the focusable eyepieces according to the user's vision defect, see <i>Focusing when Using Eyepiece Reticles</i> [▶ 74].

Symptom	Cause	Measure
Dirt or dust in the field of view.	Image brightness is unacceptable.	Adjust the lamp voltage or insert a conversion filter.
	Binocular tube is misaligned optically, mechanically.	Call in service personnel for check-up/ repair.
	Condenser is not focused properly and front lens is not in the correct on or off mode.	Focus the condenser and turn the front lens either on or off appropriately, see <i>Setting Up for Transmitted Light Brightfield Microscopy Using the KÖHLER Method</i> [▶ 78].
	Opening of the aperture diaphragm is too small.	Adjust the opening of the aperture diaphragm according to the 2/3-rule or according to the texture of the sample, see <i>Setting Up for Transmitted Light Brightfield Microscopy Using the KÖHLER Method</i> [▶ 78].
Halogen lamp 12 V, 50 W does not glow although the switch in the On position.	Dirt or dust on optical surfaces of objectives, eyepieces, condensers, filters or samples.	Clean the optical surfaces of the soiled components, see <i>Cleaning an Optical Surface</i> [▶ 108].
	Power plug is not plugged into the outlet.	Insert the plug into the outlet. Make sure outlet and instrument are adjusted to the correct voltage.
	Halogen lamp 12 V, 50 W is not mounted.	Insert halogen lamp 12 V, 50 W, see <i>Exchanging the 12 V, 50 W Halogen lamp of the HAL 50 Halogen Illuminator</i> [▶ 109].
	Halogen lamp 12 V, 50 W is defective.	Exchange the halogen lamp 12 V, 50 W, see <i>Exchanging the 12 V, 50 W Halogen lamp of the HAL 50 Halogen Illuminator</i> [▶ 109].
	Fuses are defective.	Exchange the fuses, see <i>Exchanging the Fuses T 15A H 250V in the Stand</i> [▶ 110].
	The installed electrical equipment may be defective.	Call in the service personnel to check or exchange the components, if necessary, see <i>Contact</i> .
	No voltage in the power socket.	Use another power socket.

Symptom	Cause	Measure
Halogen lamp 12 V, 50 W flickers, illumination intensity is not stable.	Halogen lamp 12 V, 50 W is reaching the end of its life span.	Exchange the halogen lamp 12 V, 50 W, see <i>Exchanging the 12 V, 50 W Halogen lamp of the HAL 50 Halogen Illuminator</i> [▶ 109].
	power cord is not installed properly or is damaged.	Install the power cord properly or exchange it.
	The pins of the halogen lamp 12 V, 50 W are not properly inserted in the socket.	Insert the pins of the halogen lamp 12 V, 50 W correctly, see <i>Exchanging the 12 V, 50 W Halogen lamp of the HAL 50 Halogen Illuminator</i> [▶ 109].

8.1 Resetting the Microscope to the Factory Settings

NOTICE

Use this function with caution as it will reset all existing configurations.

The default factory settings are:

- The Light Manager is enabled, but no light intensity values are saved.
- The light intensity is set to the initial minimum value.
- All stored configurations are cleared.

Prerequisite ✓ The microscope is operational.

Procedure 1. Press and hold down the **Intensity/LM** knob for 20 seconds.

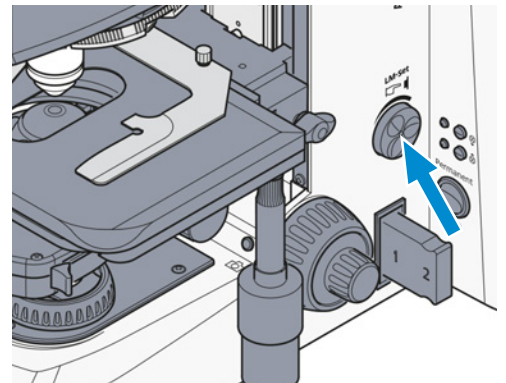

→ While the knob is held down from 3 s to 20 s, the indicator light blinks in RED.

→ After 20 s the indicator light blinks green.

↳ When the indicator stops blinking and remains GREEN, the reset to the default factory setting is successful.

9 Decommissioning and Disposal

This chapter contains information on the decommissioning and disposal of the microscope and its expansions/components or accessories.

9.1 Decommissioning

If the microscope and its components are not used for an extended period of time such as several months, they should be shut down completely and secured against unauthorized access.

DANGER

Electric injury due to live parts

When the microscope and its components are still switched on, coming in contact with live parts can lead to electric shock or burn.

- ▶ Switch off the microscope and its components prior to opening or cleaning.
- ▶ Disconnect the microscope and its components from the mains.

- Procedure**
1. Switch off the microscope.
 2. Pull the power supply plug.
 3. Protect microscope using a dust cover.

9.2 Transport and Storage

CAUTION

Muscle strains and back injuries due to lifting heavy objects

The component is heavy. If lifted alone, the weight can cause muscle strains and back injuries.

- ▶ Only handle this component with the help of a second person.

The following regulations must be observed before and during transport:

- The boxes must be secured during transport.
- Avoid rocking the boxes back and forth.
- Note the weight information on the package and on the shipping document.
- Where possible, the original packaging must be used for shipping or transport.
- Do not drop or bump the boxes during movement or storage. Acceleration must not exceed 10 g.
- Evaluate packaging shock and tilting sensors on delivery and after internal transport.

Maximum shock resistance

Allowable environmental conditions

Off-site transportation and storage in shipping packaging:

- Between -40 °C and +70 °C
- Relative humidity less than 95 % at +40 °C

On-site storage without packaging:

- Between +10 °C and +40 °C
- Relative humidity less than 75 % at +35 °C

Info

24 hours before installation of the microscope it is required that the boxes are at recommended room temperature to avoid ingress of humidity, which is harmful to optical paths, and to ensure effective stability of the microscope during installation and testing.

9.3 Disposal

The microscope and its components must not be disposed of as domestic waste or through municipal disposal companies. They must be disposed of in accordance with applicable regulations (WEEE Directive 2012/19/EU). ZEISS has implemented a system for the return and recycling of devices in member states of the European Union that ensures suitable reuse according to the EU Directives mentioned.

ZEISS introduced a procedure for the return and recycling of the instruments within the member states of the European Union which ensures suitable recycling procedures conforming to the EU directives.

For more information on disposal and recycling consult your ZEISS Sales & Service Partner. The microscope may not be disposed of in the household waste or through municipal waste disposal services. If the microscope is resold, the seller shall be obliged to inform the buyer that the microscope must be disposed of in accordance with the regulations.

The customer is responsible for decontamination.

9.4 Decontamination

A decontamination statement must be submitted before returning any used objects to the ZEISS location.

If reliable decontamination cannot be guaranteed, the hazard must be marked according to applicable regulations. In general, a well-visible warning sign must be affixed to the article itself and to the outside of the packaging, together with detailed information on the type of contamination.

10 Technical Data and Conformity

This chapter contains important technical data as well as information on the conformity.

10.1 Performance Data and Specifications

Weight and Sizes	Main Components	Width (mm)	Depth (mm)	Height (mm)	Weight (kg)
	Axioscope 5/7	240	293.5	367.5	14-20
	Axioscope 5 Vario	458.5	129	700	32
Location requirements	The microscope may only be operated in closed rooms. The microscope should not be installed near radiators or windows with direct sunlight. The microscope must be placed securely on the table surface to prevent slipping and falling. Compliance with the installation requirements of the microscope is the responsibility of the customer. The requested supplies have to be readily available at the time of installation.				
	Installation site	Exclusively inside buildings			
	Altitude	Max. 2000 m above sea level			
	Atmospheric pressure	Min. 800 hPa			
Air Conditioning and Quality	Temperature for operation	+10 °C to + 40 °C			
	Relative humidity (without condensation)	< 75 %			
	Atmospheric pressure / altitude	800 to 1060 hPa / ≤ 2000 m above sea level			
	Pollution degree	2			
	Operational area	closed rooms			
Mains connection Microscope stand	Protection class	I			
	Ingress protection rating	IP20 (IEC 60529)			
	Oversvoltage category	II			
	Nominal AC voltage Axioscope 5/7 with internal power supply	100 to 240 V (AC), ±10 %			
	Nominal AC voltage Axioscope 5 Vario with external power supply	100 to 240 V (AC), ±10 %			
	Nominal frequency	50 to 60 Hz			
	Power consumption Axioscope 5 with internal power supply	120 VA			
	Power consumption Axioscope 7 with internal power supply	100 VA			
	Power consumption Axioscope 5 Vario with external power supply	30 VA			

	Main power plug	Local mains plug will be supplied.
	Addition building PE	The system must be connected to a building earth point at all times. (not applicable for Axioscope 5 Vario)
	Fuses in the Axioscope 5/7 stand	2x T 3.15 A/H, 5x20 mm (in compliance with IEC 127)
	Fuses in the HBO 100 W power supply unit	T 2.0 A/H, 5x20 mm (in compliance with IEC 127)
	Fuses in the external power supply for HAL 100	2x T 5.0 A/H, 5x20 mm (in compliance with IEC 127)
Mains connection Dual observation	Protection class	II
	Overtoltage category	II
	Nominal AC voltage (power adapter)	100 to 240 V (AC), $\pm 10\%$
	Nominal frequency (power adapter)	50/60 Hz
	Nominal input current	0.2 A
	Power consumption (Dual observation)	5 VA (5 VDC, 1 A)
	LED illumination TL/RL	Power consumption
Adjustment of light source		continuous approx. 10 to 800 mA
Halogen illumination 12 V, 50 W	Adjustment of light source	continuous approx. 3 to 12 V
	Adjustment of light source	continuous approx. 3 to 12 V
Halogen illumination 12 V, 100 W	Adjustment of light source	continuous approx. 3 to 12 V
HBO 100 illumination	Power consumption	100 VA V
LED illumination fluorescence	Wavelengths optional	385, 470, 505, 565, 590, 625 nm

Stand specifications	Focusing	manual/motorized stage focusing
	Coarse focusing	approx. 4 mm/revolution
	Fine focusing	approx. 0.4 mm/revolution; 2 µm scale interval
	Lifting range	approx. 25 mm
	Height stop	factory pre-set, mechanically variable
	Objective change	manual
	Reflector module change	manual

Tube specifications	Tube specifications			
	Type	Viewing angle	Adjustment	Viewing height* in mm
	Binocular tube 30°/23	30°	- None -	449/485
	Binocular photo tube 30°/23 (50:50)	30°	- None -	449/485
	Binocular photo tube 30°/23 (100:100)	30°	- None -	449/485
	Binocular photo tube 20°/23 (100:100)	20°	- None -	442/481
	Binocular ergo tube 15°/23 (50/50), telescopic, height, upright image	15°	height, telescopic	410/509
	Binocular tube 20°/23	20°	- None -	442/481
	Binocular photo tube 20°/23 Pol (100:100)	20°	- None -	442/481
	Binocular ergo tube 20°/23 (100/100), reverse image, 44 mm height	20°	height	457/574
	Binocular Ergo Photo Tube -2° to 28°/23 (50:50)	-2° to 28°	height	356/507
	Binocular Ergo Photo Tube -2° to 28°/23 (50:50)	-2° to 28°	- None -	392/537

* Range between the lower and upper setting of the eyepieces, e.g. 442/481 → 442 mm to 481 mm

All specifications are for an inter-pupillary distance of 65 mm.

10.2 Applicable Standards and Regulations

Observe all general and country-specific safety regulations as well as applicable environmental protection laws and regulations.

The microscope is in compliance with the requirements of the following regulations and directives:

2011/65/EU and delegated directive (EU) 2015/863	Directive 2011/65/EU of the European Parliament and of the Council of 8 June 2011 on the restriction of the use of certain hazardous substances in electrical and electronic equipment (RoHS), amended by Commission Delegated Directive (EU) 2015/863 of 31 March 2015
EN 61010-1:2019	Safety requirements for electrical equipment for measurement, control, and laboratory use – Part 1: General requirements
EN IEC 61326-1:2021	Electrical equipment for measurement, control and laboratory use - EMC requirements - Part 1: General requirements
Only applicable for Axioscope 5/7 MAT	
2014/30/EU	Directive 2014/30/EU of the European Parliament and of the Council of 26 February 2014 on the harmonization of the laws of the Member States relating to electromagnetic compatibility
2014/35/EU	Directive 2014/35/EU of the European Parliament and of the Council of 26 February 2014 on the harmonization of the laws of the Member States relating to the making available on the market of electrical equipment designed for use within certain voltage limits
Applicable for all Axioscope microscopes except Axioscope 5/7 MAT	
(EU) 2017/746	Regulation (EU) 2017/746 of the European Parliament and of the Council of 5 April 2017 on in vitro diagnostic medical devices and repealing Directive 98/79/EC and Commission Decision 2010/227/EU
EN IEC 61010-2-101:2022	Safety requirements for electrical equipment for measurement, control, and laboratory use - Part 2-101: Safety requirements for in vitro diagnostic (IVD) medical equipment
EN IEC 61326-2-6:2021	Electrical equipment for measurement, control and laboratory use - EMC requirements - Part 2-6: Particular requirements - In vitro diagnostic (IVD) medical equipment

According to directive 2011/65/EU (RoHS) the microscope and its accessories have been classified as instrument category 9 (Monitoring and control instruments including industrial monitoring and control instruments). They also fall under 2012/19/EU (WEEE).

European and International Directives / Standards: For more information on ISO and CSA certificates or CE Declarations of Conformity, contact your ZEISS Sales & Service Partner.

10.3 Usability of LED Modules for the Colibri 3 LED Light Source

Position	Slot 1	Slot 2	Slot 3	Slot 4
Wavelength range (nm)	450-480	350-415	594-660	508-565
LED module 385 nm (423052-9593-000)	X	O	X	X
LED module 470 nm (423052-9573-000)	O	X	X	X
LED module 505 nm (423052-9562-000)	X	X	X	O
LED module 565 nm (423052-9602-000)	X	X	X	O
LED module 590 nm (423052-9543-000)	X	X	O	X
LED module 625 nm (423052-9522-000)	X	X	O	X

O = usable

X = not usable

11 Accessories and System Expansions

Only the following accessories may be used with the microscope as their safe use has been confirmed by ZEISS. Only original parts from ZEISS may be used. Check in advance whether your microscope can be retrofitted with a system expansion or accessories.

After installation or conversion it must be carefully checked whether the microscope and its system expansions/accessories are in a safe operational state and whether unused ports are closed. For details and safety measures refer to the associated documents.

Info

For additional information and detailed descriptions, refer to further applicable documents or ask your ZEISS Sales & Service Partner.

Name	Description/Info
Objectives	<p>The performance of the microscope objectives affects the image quality of your microscope like no other system component. Whether you work with histological samples, cell samples or entire organisms – the suitability of microscope objectives for your application depends on various factors.</p> <p>More detailed information on available and recommended objectives can be found at https://www.micro-shop.zeiss.com/de/de/shop/objectives or ask your ZEISS Sales & Service Partner.</p>
Sliders	<p>The following sliders are available:</p> <ul style="list-style-type: none"> ▪ Analyzer slider D/A, with lambda plate, 360° rotatable ▪ Analyzer slider D/A, 360° fixed ▪ Analyzer slider D/A, with lambda plate, each rotatable +/- 10° ▪ Slider 12x46, with focusing Bertrand lens, for phase contrast and conoscopy
Polarizers	<p>The following polarizers are available:</p> <ul style="list-style-type: none"> ▪ Polarizer D, fixed, removable ▪ Polarizer, fixed, ±10° W-E adj. ▪ Polarizer D, 90°, rotatable, removable ▪ Polarizer, 90°, ±10° W-E adj. ▪ Polarizer, fixed, with lambda plate, rotatable ▪ Polarizer, rotatable, with color filter carrier ▪ Polarizer, 90°, ±10° W-E adj., with filter carrier ▪ Circular polarizer D ▪ 360-degree rotatable polarizer ▪ circular polarizing equipment D ACR, with rotatable lambda/4 plate ▪ Polarizer on field aperture ▪ Low-power system for objectives 2.5x/4x for condenser 0.9/1.25 H ▪ Color filter carrier 3x for filter d=32 mm
Eyepieces	<p>The following eyepieces and accessories are available:</p> <ul style="list-style-type: none"> ▪ Eyepiece E-PL 10x/23 GW, foc. ▪ Eyepiece PL 10x/23 GW, foc.

Name	Description/Info
	<ul style="list-style-type: none"> ▪ Eyepiece PL 10x/23 GW, foc. POL with crossline graticule ▪ Auxiliary microscope ▪ Pinhole diaphragm D= 30 mm
Condensers	<p>The following condensers are available:</p> <ul style="list-style-type: none"> ▪ Ultra condenser 1.2/1.4 (0.75-1.0) ▪ Dry darkfield condenser 0.8/0.95 (0.6-0.75) ▪ Condenser 0.9/1.25 H ▪ Condenser 0.9 H Pol ▪ Condenser 0.8 BF WD=5.8mm ▪ Condenser, achrom.-aplan. 0.9 BF ▪ Condenser, achrom.-aplan. 0.9 BF DF PhC DIC ▪ Condenser, achrom.-aplan. 0.9 BF Pol
Stages	<p>The following stages are available:</p> <ul style="list-style-type: none"> ▪ Mechanical stage, 80x60, motorized ▪ Rotary stage, Pol, 360°, with clickstop ▪ Mechanical stage, 75x50/240° R ▪ Mechanical stage, 75x50 R ▪ Mechanical stage, 75x50 L ▪ Mechanical stage 75x50 R, with special surface for high load capacity ▪ Mechanical stage, 75x50 R for reflected light
Sample holders	<p>The following sample holders are available:</p> <ul style="list-style-type: none"> ▪ Specimen holder for reflected light ▪ Specimen holder for dual slides 76x26 ▪ Attachable object guide Pol, 28x48 mm
Light sources	<p>The following light sources are available:</p> <ul style="list-style-type: none"> ▪ LED module 385 nm for Axio ▪ LED module 470 nm for Axio ▪ LED module 505 nm for Axio ▪ LED module 565 nm for Axio ▪ LED module 590 nm for Axio ▪ LED module 625 nm for Axio ▪ Illuminator RL LED 10 Axioscope ▪ Illuminator TL LED 10 Axioscope ▪ HXP 120 V light source ▪ Colibri 3 light source ▪ HBO 100 light source ▪ HAL 50 light source ▪ HAL 100 light source ▪ Viluma 5/7 light source

Name	Description/Info
Tubes	<p>The following tubes are available:</p> <ul style="list-style-type: none"> ▪ Binocular ergophototube 20°/23 (100:0/0:100), reversed image ▪ Binocular ergophototube 20°/23 MAT (100:0/0:100), reversed image ▪ Binocular ergophototube 15°/23 (50:50), upright image ▪ Binocular ergophototube -2° to 28°/23 (50:50), reversed image ▪ Binocular ergophototube -2° to 28°/25 (50:50), reversed image ▪ Binocular tube 30°/23, reversed image ▪ Binocular tube 30°/23, upright image ▪ Binocular phototube, 30°/23 (50:50), reversed image ▪ Binocular phototube, 30°/23 (100:0/0:100), reversed image ▪ Binocular phototube, 20°/23 (100:0/0:100), upright image ▪ Binocular phototube, Pol, 20°/23 (100:0/0:100), upright image ▪ Binocular phototube, 30°/23 (98:2), reversed image ▪ Binocular phototube 30°/23 (100:0/30:70/0:100), reversed image
Reflector inserts	<p>The following reflector inserts are available:</p> <ul style="list-style-type: none"> ▪ Reflector slider, 2x encoded, changeable ▪ Reflector turret, 4x encoded, changeable ▪ Reflector turret, 6x encoded, changeable
Cameras	<p>The following cameras and accessories are available:</p> <ul style="list-style-type: none"> ▪ Axiocam 203 mono ▪ Axiocam 212 color ▪ Camera adapter 60N-C 2/3" 0.5x ▪ Camera adapter 60N-C 2/3" 0.63x ▪ Camera adapter 60N-C 1" 1.0x ▪ Video adapter 60 C 1/3" 0.4x

11.1 Binocular Tube

Various tubes with different inclination angles enable suitable eye levels to be selected for observation.

11.1.1 Binocular Tube 30°/23

Purpose Binocular tubes are used to observe the microscopic image by means of the eyepieces.

Position The binocular tubes are mounted on the top of the stand.

Function The pupil distance and the viewing height can be adjusted with the aid of the binocular section.

The following features and controls are available:

- Optionally with upright or reversed image
- viewing angle 30°
- field of view 23 mm

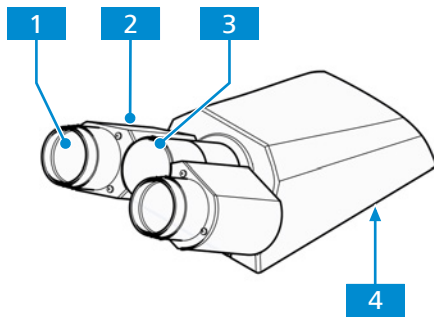

Fig. 40: Binocular Tube 30°/23

- | | |
|--------------------------|------------------------------|
| 1 Eyepiece socket | 2 Binocular section |
| 3 Angle scale | 4 Dovetail ring mount |

11.1.2 Binocular Photo Tube Pol 20°/23 (100:0/0:100)

Purpose Binocular photo tubes are used to observe the microscopic image by means of the eyepieces and/or acquire images with a camera. Using the camera port, the microscopic image can be sent to a connected camera.

Position The binocular photo tube is mounted on the top of the stand.

Function The pupil distance and the viewing height can be adjusted with the aid of the binocular section.

The following features and controls are available:

- upright image
- camera port with toggle graduation (100:0/0:100)
- viewing angle 20°
- field of view 23 mm

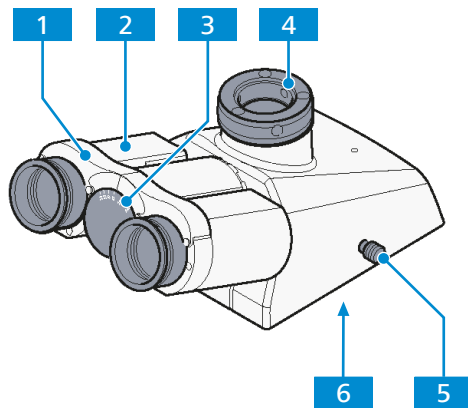

Fig. 41: Binocular Photo Tube Pol 20°/23 (100:0/0:100)

- | | |
|--|------------------------------|
| 1 Eyepiece socket | 2 Binocular section |
| 3 Angle scale | 4 Camera port |
| 5 Slider for selecting the graduation | 6 Dovetail ring mount |
- Slider pushed in: 100% light to eyepieces
 - Slider pulled out: 100% light to camera

11.1.3 Binocular Ergo Photo Tube 20°/23 (100:0/0:100)

Purpose Binocular photo tubes are used to observe the microscopic image by means of the eyepieces and/or acquire images with a camera. Using the camera port, the microscopic image can be sent to a connected camera.

Position The binocular photo tube is mounted on the top of the stand.

Function The pupil distance and the viewing height can be adjusted with the aid of the binocular section.

The following features and controls are available:

- upright image
- camera port with toggle graduation (100:0/0:100)
- viewing angle 20°
- field of view 23 mm, usable 22 mm
- vertical adjustment of 44 mm with vertical scale

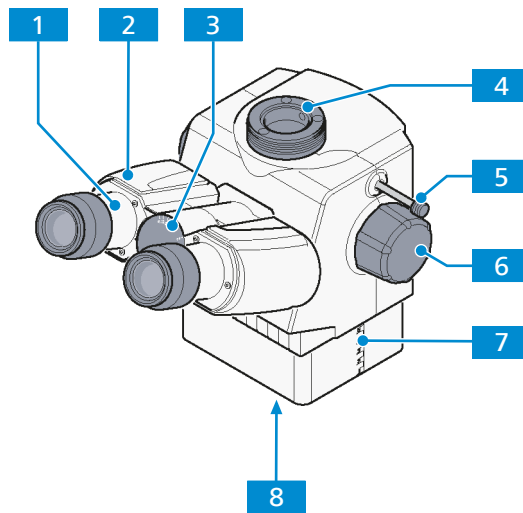

Fig. 42: Binocular Ergo Photo Tube 20°/23 (100:0/0:100)

- | | |
|---|---|
| 1 Eyepiece socket | 2 Binocular section |
| 3 Angle scale | 4 Camera port |
| 5 Slider for selecting the graduation <ul style="list-style-type: none"> ▪ Slider pushed in: 100% light to eyepieces ▪ Slider pulled out: 100% light to camera | 6 Rotary knob for vertical adjustment (right and left) |
| 7 Vertical scale | 8 Dovetail ring mount |

11.1.4 Binocular Ergo Photo Tube 15°/23 (50:50)

Purpose Binocular tubes are used to visualize the microscopic image by means of the eyepieces.

Position The binocular tubes are mounted on the top of the stand.

Function The pupil distance and the viewing height can be adjusted with the aid of the binocular section.

Depending on the design, the following features and controls are available:

- upright image
- camera port with fixed light graduation (50:50)
- viewing angle 15°
- eyepiece shutter
- field of view 23 mm
- vertical adjustable and extendable

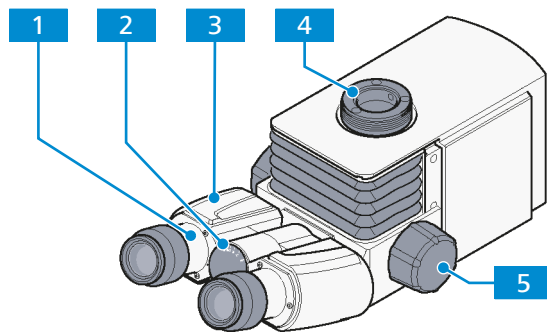

Fig. 43: Variants of binocular tubes

- | | |
|--|---|
| <p>1 Eyepiece socket</p> <p>3 Binocular section</p> <p>5 Rotary knob for vertical adjustment (right and left)</p> | <p>2 Angle scale</p> <p>4 Camera port</p> |
|--|---|

11.1.5 Binocular Photo Tube 30°/23 (98:2), Reversed Image

Purpose Binocular photo tubes provide users with the convenience of accessing the sample images using eyepieces as well as monitors through camera at the same time. This specific splitting ratio allow users to look at the sample with naked eyes even though light intensity is set to maximum level.

Position The binocular photo tubes are mounted on the top of the stand.

Function The pupil distance and viewing height can be adjusted by bending the binocular device up or down.

The following features and controls are available:

- Reverse image
- Camera port with splitting ratio 98:2
- Viewing angle 30°
- Field of view 23 mm

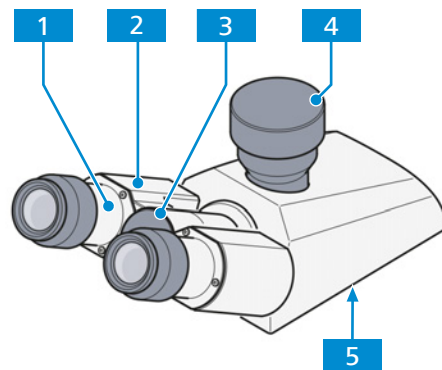

Fig. 44: Binocular photo tube 30°/23 (98:2), reversed image

- | | | | |
|----------|---------------------|----------|-------------------|
| 1 | Eyepiece socket | 2 | Binocular section |
| 3 | Angle scale | 4 | Camera port |
| 5 | Dovetail ring mount | | |

11.1.6 Binocular Photo Tube 30°/23 (100:0/30:70/0:100), Reversed Image

Purpose Binocular photo tubes provide users with the convenience of accessing the sample images using eyepieces as well as monitors through camera at the same time. This specific splitting ratio allows users to freely switch between looking at the sample with naked eyes or using monitors or at simultaneously.

Position The binocular photo tubes are mounted on the top of the stand.

Function The pupil distance and viewing height can be adjusted by bending the binocular device up or down.

The following features and controls are available:

- Reverse image
- Camera port with splitting ratio 100:0/30:70/0:100
- Viewing angle 30°
- Field of view 23 mm

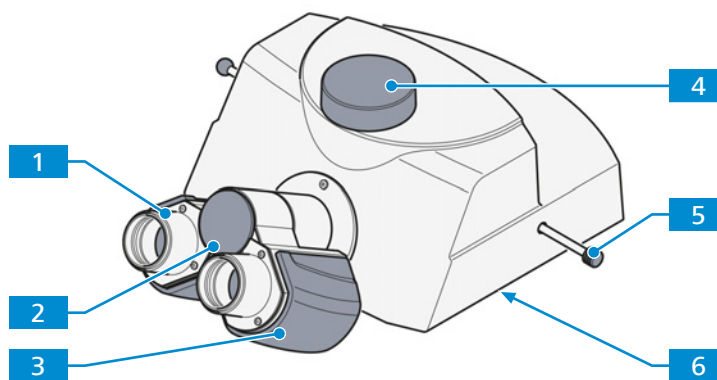

Fig. 45: Binocular photo tube 30°/23 (100:0/30:70/0:100), reversed image

- | | |
|---|------------------------------|
| 1 Eyepiece socket | 2 Angle scale |
| 3 Binocular section | 4 Camera port |
| 5 Slider for selecting the graduation (right and left) | 6 Dovetail ring mount |
- Slider pushed in: 100% light to eyepieces
 - Slider pushed in to the middle: 30% light to eyepieces, 70% light to camera
 - Slider pulled out: 100% light to camera. 100% light to camera

11.2 Light Sources

11.2.1 HAL 100 Light Source

Position The HAL 100 light source can be mounted onto the transmitted or the reflected light path.

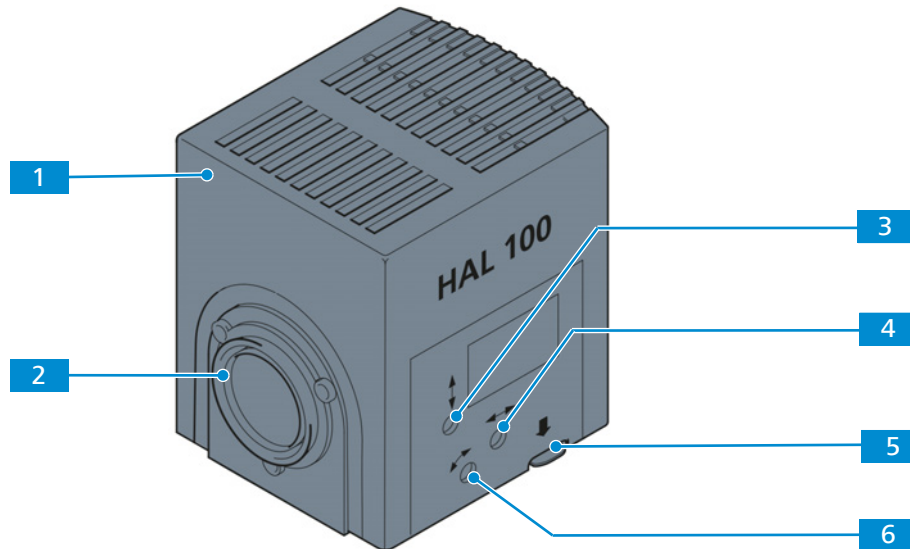

Fig. 46: HAL 100

- | | |
|-----------------------------------|-------------------------------------|
| 1 Lamp housing | 2 Dovetail ring |
| 3 Vertical adjusting screw | 4 Horizontal adjusting screw |
| 5 Release latch | 6 Adjusting screw |

11.2.1.1 Labels on the Power Supply 12 V 100 W

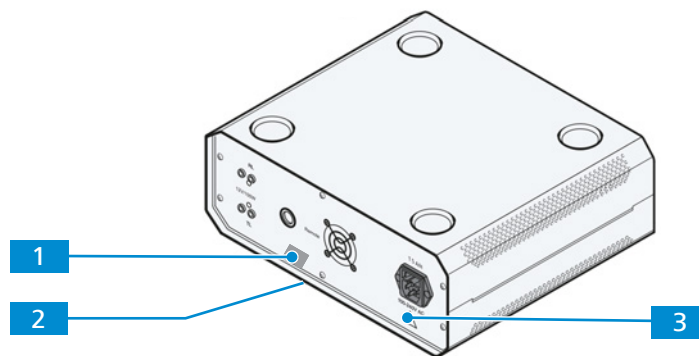

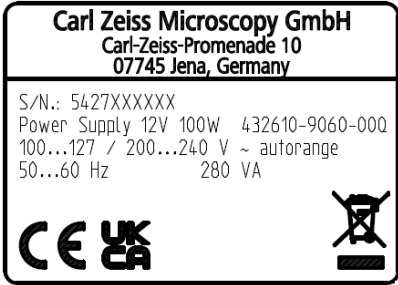



Fig. 47: Labels on the Power Supply 12 V 100 W

Pos.	Label or light	Explanation
1		Pull the power plug before opening.
2		Type label
3		Observe notes in the instruction manual and the supplied documents.

11.2.1.2 Controls and Functional Elements of Power Supply 12 V 100 W

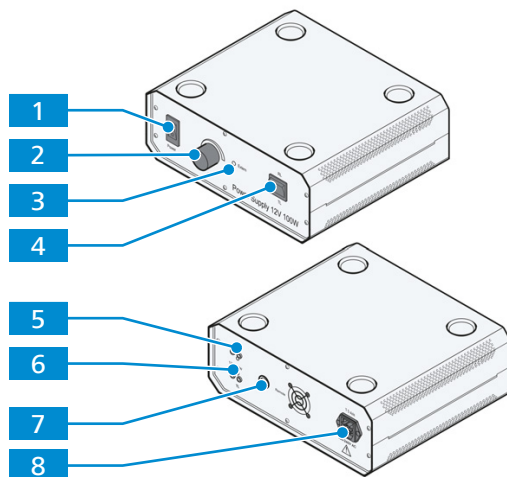

Fig. 48: Controls and Functional Elements of the Power Supply 12 V 100 W

- | | |
|---|---|
| 1 Power switch | 2 Dimmer |
| 3 Indicator light for remote control operation | 4 Toggle switch for RL and TL |
| 5 Connection port for reflected light lamp RL | 6 Connection port for transmitted light lamp TL |
| 7 Connection port for illumination intensity control cable Remote | 8 Mains socket |

11.2.1.3 Assembling the HAL 100 Light Source for Transmitted Light Illumination

⚠ CAUTION

Eye damage or skin irritation due to hazardous light emission

The light source belongs to Risk Group 2 as specified in IEC 62471 and emits optical radiation and UV radiation. Eye damage or skin irritation may result from exposure.

- ▶ Never look directly into the light-emitting aperture of the light source.
- ▶ Avoid exposure of skin to the radiation. Use suitable protective equipment/protective clothing if required.
- ▶ Before installing or removing the light source always make sure it is switched off.

NOTICE

Heat damage

The HAL 100 bulb replacement tool might suffer damage from the emitted heat during the light source operation.

- ▶ Remove the bulb replacement tool from the HAL 100 housing before installing the light source.
- ▶ Do not operate the light source with the bulb replacement tool inside its housing.

Info

The light source cannot be mounted onto the standard stand.

When using the HAL or HBO light sources, a base plate for the Axioscope (000000-2202-526) is mandatory.

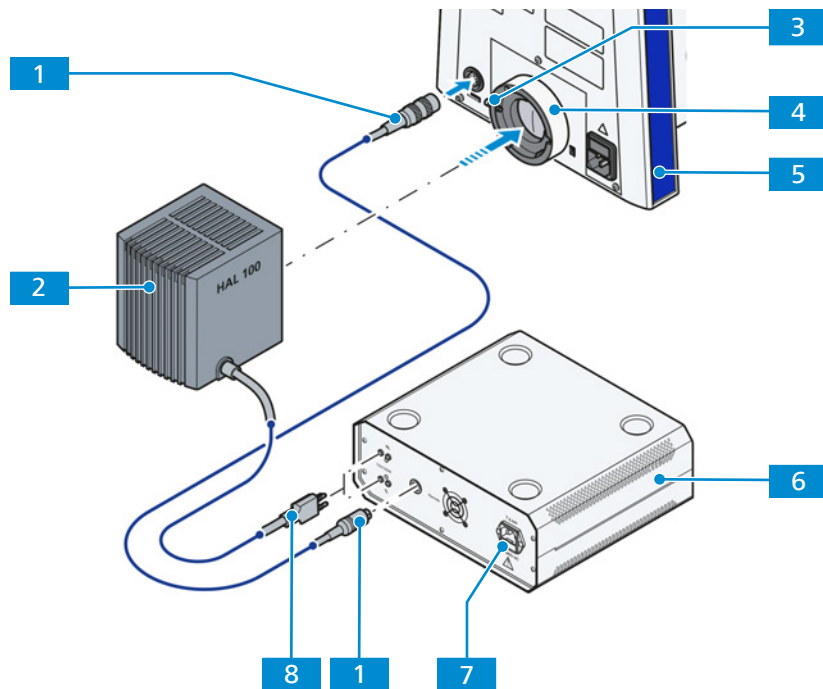

Parts and Tools  Hex key, 3.0 mm

- Prerequisite**
- ✓ The microscope is switched off.
 - ✓ The stand **5** is equipped with the illumination mount **4**.
 - ✓ The protective cap is removed from the illumination mount.
 - ✓ *The base plate is installed. [▶ 64]*
 - ✓ The external power supply for HAL 100 light source **6** is switched off.
 - ✓ The bulb replacement tool is *removed [▶ 136]* from the light source housing.

- Procedure**
1. Loosen the clamping screw **3** on the illumination mount **4** of the carrier for transmitted-light illumination.
 2. Insert the dovetail ring of the HAL 100 **2** into the illumination mount.
 3. Tighten the clamping screw **3**.
 4. At the external power supply, insert the plug of the light source's cable **8** into the **TL** port.
 5. At the external power supply, insert the cable for illumination intensity control **1** into the **Remote** port.
 6. At the back of the stand, insert the cable for illumination intensity control into the **Remote** port.
 7. Switch the toggle switch for reflected or transmitted light to the **TL** position (transmitted light).
 8. Connect the mains socket **7** of the external power supply to a mains. Use the power cord.

Proceed in the reverse order for removal.

11.2.1.4 Assembling the HAL 100 Light Source for Reflected Light Illumination

For assembling the HAL 100 light source for reflected light illumination, proceed in the same way as *transmitted light illumination [▶ 133]*.

11.2.1.5 Adjusting the HAL 100 Light Source

CAUTION

Burning hazard due to hot light sources

Light sources can become hot during processing.

- ▶ Avoid touching the hot light source housing.
- ▶ Let the light source cool down before touching it.

CAUTION

Eye injury due to light emission

Directly looking into emitted light can damage the eye.

- ▶ Do not look into the light exit aperture of the light source.

The following action comprises several action sequences. These sequences are to be carried out in the specified order.

- *Coarse Adjusting [▶ 135]*
- *Fine Adjusting [▶ 135]*

11.2.1.5.1 Coarse Adjusting

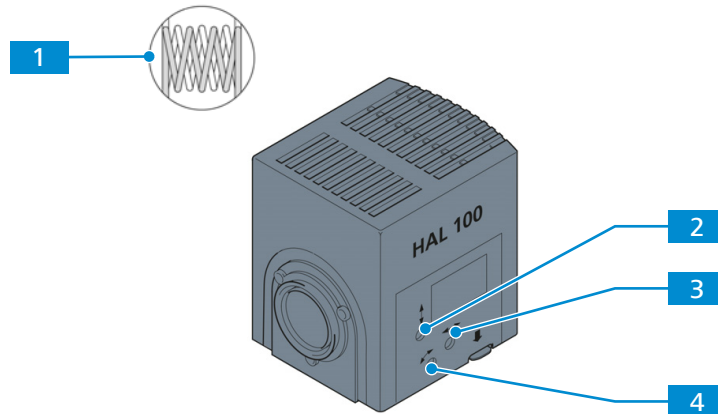

Parts and Tools  Hex key, 3.0 mm

- Prerequisite**
- ✓ The microscope is switched off.
 - ✓ The light source is installed on the microscope (see *Assembling the HAL 100 Light Source for Transmitted Light Illumination* [▶ 133] or *Assembling the HAL 100 Light Source for Reflected Light Illumination* [▶ 134]).
 - ✓ The light source has cooled down.

- Procedure**
1. **NOTICE** Make sure the light source does not fall when unfixing it. Hold the light source and loosen the clamping screw at the light source mount of the stand.
 2. Remove the light source and direct its aperture orthogonally to a projection surface in a distance of at least 3 m.
 3. Switch on the external power supply of the HAL 100 light source.
 - The light switches on and two images of the lamp filament are projected onto the projection surface **1**.
 4. Adjust the adjusting screw **3** such that both images appear as sharp as possible.
 5. Adjust the adjusting screws **2** and **4** so that the lamp filament of one image exactly fills the gaps of the reflected image.

11.2.1.5.2 Fine Adjusting

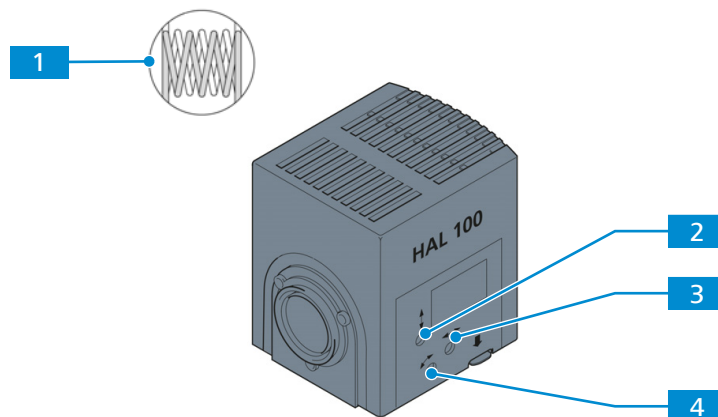

Parts and Tools  Hex key, 3.0 mm

- Prerequisite**
- ✓ *The light source is coarsely adjusted. [▶ 135]*
 - ✓ The light source is mounted to the microscope.
 - ✓ The plug of the light source's cable is connected to the corresponding socket at the external power supply.
 - ✓ All filters are removed from the beam path.

- Procedure**
1. Swivel in an objective with a magnification of 40x or lower.
 2. Bring a free area of the sample into the beam path.
 3. Remove the eyepiece from the tube.
 4. While watching the two lamp filament images **1** through the tube, adjust the adjusting screws **2** and **4** to center the filaments in the eye pupil image.
 5. Adjust the adjusting screw **3** such that the illumination of the image is as homogenous as possible.

11.2.1.6 Exchanging the Halogen Bulb 12 V, 100 W

CAUTION

Eye damage or skin irritation due to hazardous light emission

The light source belongs to Risk Group 2 as specified in IEC 62471 and emits optical radiation and UV radiation. Eye damage or skin irritation may result from exposure.

- ▶ Never look directly into the light-emitting aperture of the light source.
- ▶ Avoid exposure of skin to the radiation. Use suitable protective equipment/protective clothing if required.
- ▶ Before installing or removing the light source always make sure it is switched off.

CAUTION

Burning hazard due to hot light sources

Light sources can become hot during processing.

- ▶ Avoid touching the hot light source housing.
- ▶ Let the light source cool down before touching it.

The light source does not have to be removed from the microscope for replacing the bulb.

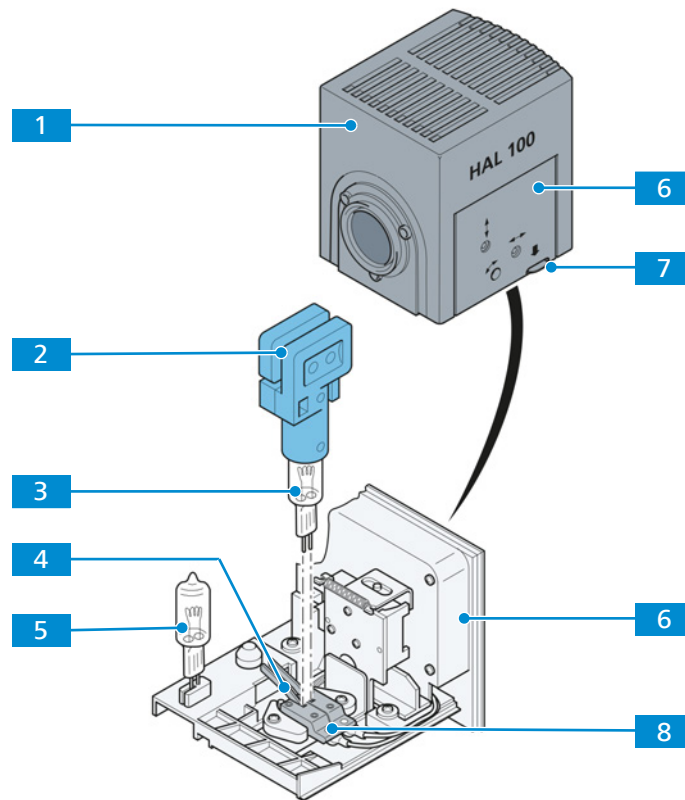

- Prerequisite**
- ✓ The microscope is switched off.
 - ✓ The plug of the light source's cable has been removed from the corresponding socket.
 - ✓ The light source has cooled down for about 15 minutes.

- Procedure**
1. Press the release button **7** and pull the bulb carrier **6** completely out to the side.
 2. Put the bulb replacement tool **2** onto the old bulb **3**.
 3. Press down the two spring levers **4** and remove the tool with the bulb in upward direction.
 4. Remove the old bulb from the replacement tool.
 5. **NOTICE Do not touch the new bulb with bare fingers! Even traces of grease can reduce its lifetime.**
Put the bulb replacement tool onto the replacement bulb **5**.
 6. Press down the two spring levers and insert the new bulb into the bulb socket **8**.
 7. To center the bulb, briefly press the spring levers once more.
 8. **NOTICE Do not leave the bulb replacement tool inside the light source.**
Slide in the lamp carrier **7** into the housing **1** until it clicks into place.

Info**How To - Replace the HAL 100 Halogen Bulb**

This video tutorial shows how to replace the halogen bulb in the HAL 100 light source. For service, support, and general contact visit www.zeiss.com/service-support.





[youtu.be.PJYnvBRLdag](https://youtu.be/PJYnvBRLdag)

11.2.1.7 Exchanging the Fuses T 5.0A H 250V of the Power Supply 12 V 100 W**⚠ DANGER****Electric injury due to live parts**

When an external power supply unit is still switched on, coming in contact with live parts can lead to electric shock or burn.

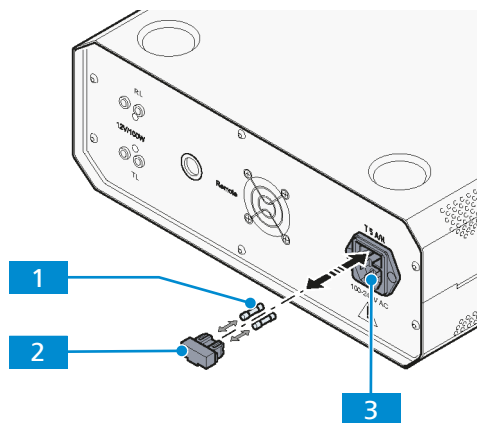
- ▶ Switch off the external power supply unit.
- ▶ Pull the power plug of the external power supply unit for safe disconnection from the power supply.



Parts and Tools  2x Fuse type T 5.0A H 250V 5x20mm

- Prerequisite**
- ✓ The microscope is switched off.
 - ✓ The power supply is switched off.
 - ✓ The power supply is disconnected from the mains.

- Procedure**
1. If the fuses fail, first check the cause and fix technical problems properly.
 2. Remove the fuse holder **2** on the rear side of the stand.
 3. Remove fuses **1** from the fuse holder.
 4. Insert new fuses.
 5. Push the fuse holder back into the fuse compartment **3** until it locks in place.
 6. Connect and switch on the power supply.
 7. Put the microscope back into operation.

11.2.2 HBO 100

Purpose The HBO 100 light source serves as a light source for the reflected light fluorescence process. The HBO 100 light source is available in two versions (manual and automatic adjustment).

Position The HBO 100 is installed on the illumination connector of the lower part of the stand.

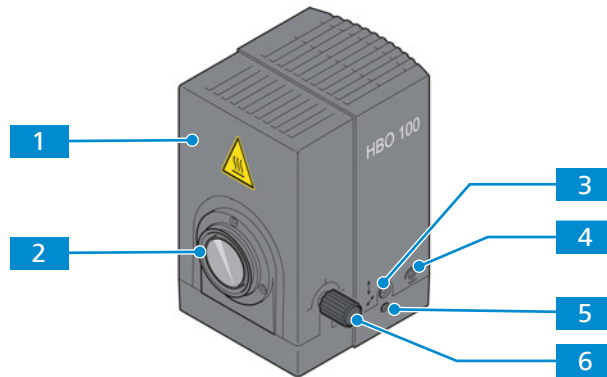

Fig. 49: HBO 100 light source

- | | |
|-------------------------------------|--|
| 1 Lamp housing | 2 Dovetail ring |
| 3 Vertical adjusting screw | 4 Locking screw |
| 5 Horizontal adjusting screw | 6 Knurled knob for collector adjustment |

11.2.2.1 Labels on the HBO 100

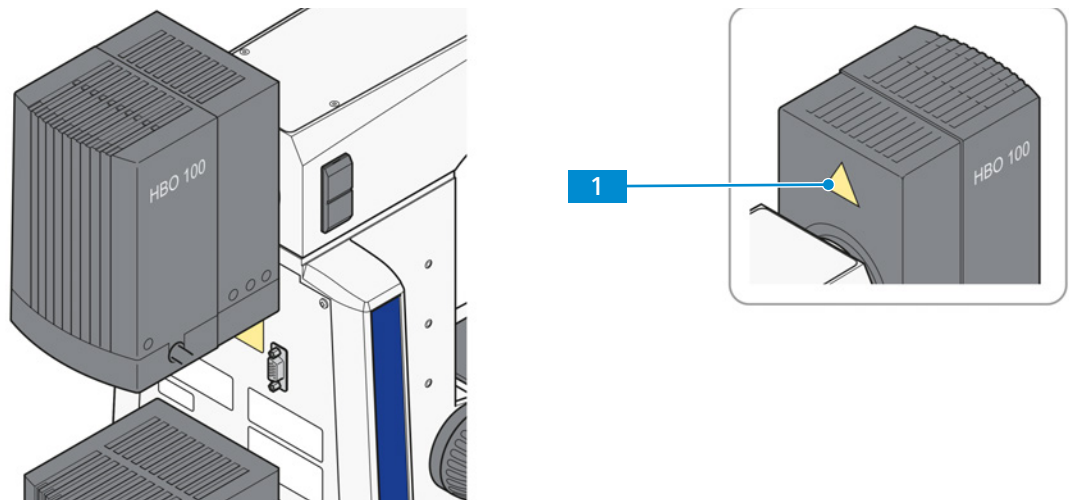

Fig. 50: Warning label on HBO 100 for reflected light

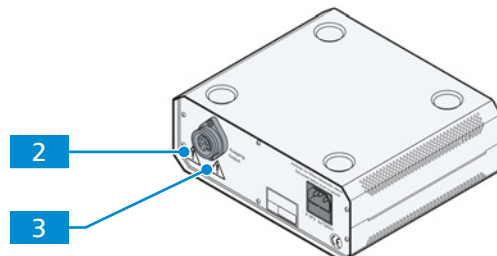





Fig. 51: Warning labels on the power supply unit for HBO 100

Pos.	Symbol	Description
1		Hot surface! Do not touch.
2		Observe notes in the instruction manual and the supplied documents.
3		High voltage! May only be opened by trained electrical engineering personnel.

11.2.2.2 Power Supply Unit for HBO 100

Purpose The power supply unit for HBO 100 is used to power the HBO 100 if it is used as a fluorescence illumination source.

Position The power supply unit can be placed beside the microscope.

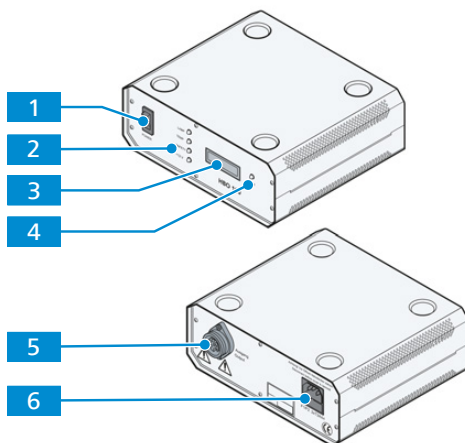

Fig. 52: Power supply unit for HBO 100 (front and rear side)

- | | |
|--|---|
| <p>1 Power switch, lights when instrument is switched on</p> <p>3 Display of operating hour meter</p> <p>5 Connection port for HBO 100 light source</p> | <p>2 Indicator lights:</p> <ul style="list-style-type: none"> ▪ LAMP, lights when the lamp has been ignited and is lighting ▪ TEMP, lights when the temperature inside the transformer is within the permissible range ▪ SAFETY, lights when the safety circuit of the lamp housing is closed ▪ +12V, lights when the additional voltage of the transformer is within the permissible range <p>4 Reset button, resets the operating hour meter to "0"</p> <p>6 Mains socket</p> |
|--|---|

11.2.2.3 Assembling the Adjustment Tool of HBO 100

This procedure applies to the following stand type only:

- Axioscope 5 Bio-TL/RL

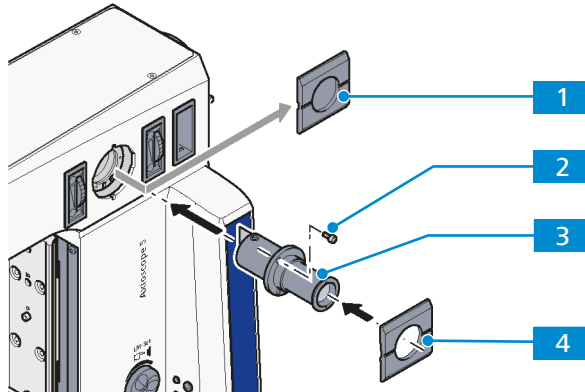

- Prerequisite**
- ✓ The microscope is switched off.
 - ✓ The HBO 100 light source is installed.

- Procedure**
1. Remove the cover cap **1** from the mounting aperture of the stand.
 2. Insert the adjustment tool **3**.
 3. Tighten the three included screws **2**.
 4. Attach the cover cap with opening **4** to the mounting aperture. Make sure it locks.
 5. Slide in the movable connecting piece of the adjustment tool.

Proceed in the reverse order for removal.

11.2.2.4 Assembling the HBO 100 Light Source

CAUTION

Eye damage due to hazardous light emission

The light source belongs to Risk Group 2 as specified in IEC 62471 and emits optical radiation. Eye damage may result from exposure.

- ▶ Never look directly into the light-emitting aperture of the light source.
- ▶ Before installing or removing the light source always make sure it is switched off.

NOTICE

Risk of damage to the gray filter

The high light intensity of the light source can damage the gray filter for reflected light during prolonged use.

- ▶ Use an attenuator instead of a gray filter to change the light intensity in the reflected light path.

Info

The light source cannot be mounted onto the standard stand.

When using the HAL or HBO light sources, a base plate for the Axioscope (000000-2202-526) is mandatory.

Info

For installing or replacing the HBO 103 W/2 mercury vapor short-arc bulb at the HBO 100 light source, consult the operator manual supplied with the light source.

Parts and Tools  Hex key, 3.0 mm

- Prerequisite**
- ✓ The microscope is switched off.
 - ✓ *The base plate is installed. [▶ 64]*
 - ✓ The HBO 100 light source is switched off.
 - ✓ The HBO 103 W/2 mercury vapor short-arc bulb is installed at the light source.
 - ✓ The stand is equipped with the illumination mount.
 - ✓ The protective cap is removed from the illumination mount of the stand.

- Procedure**
1. Loosen the clamping screw **2** on the illumination mount **3**.

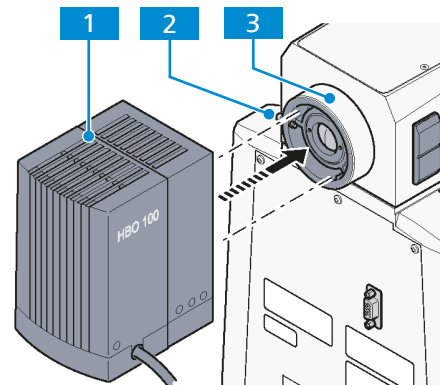

2. Insert the light source with the dovetail ring into the illumination mount.
3. Fasten the clamping screw.

4. Insert the multi-pin plug of the HBO 100 **1** into the device connector **4** on the PSU **5**.

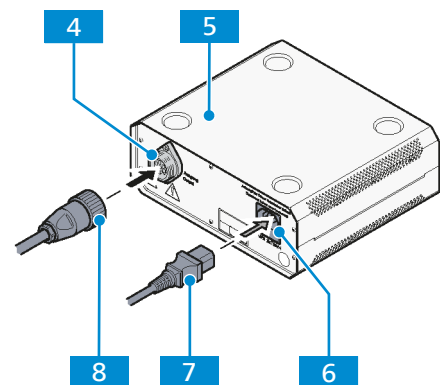

5. Fasten the connector's coupling ring **8**.
6. Connect the mains socket **6** of the PSU to the mains. Use the power cord **7**.

Proceed in the reverse order for removal.

11.2.2.5 Adjusting the HBO 100 Light Source

The self-adjusting HBO 100 light source does not require any adjustment procedure.

- Prerequisite**
- ✓ The light source is installed on the microscope.
 - ✓ The light source is switched on and has reached operational temperature.
 - ✓ If the FL attenuator is in the reflected light beam path, make sure that it is set to 100% transmission.

- Procedure**
1. Pull the adjustment tool **4** out of the microscope stand.

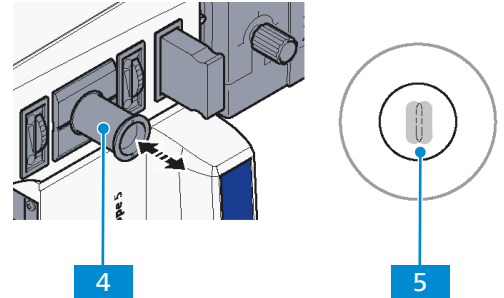

- The lighter colored focal point of the HBO 103 W/2 lamp and its slightly darker reflection **5** become visible in the black glass window of the adjustment tool.
2. Use the knurled button for collector adjustment **3** to focus the brighter focal point.

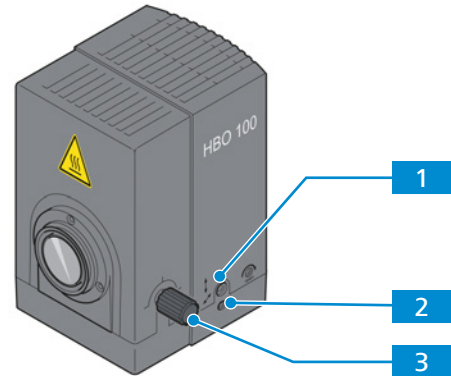

3. Use the adjustment screws **1** and **2** to bring the two focal points as close together in the adjustment circle of the adjustment tool as possible.
4. Replace the adjustment tool in its original position.

11.2.3 HXP 120 V

The HXP 120 V is a compact light source for reflected-light fluorescence microscopy applications.

Info

For further information, refer to the instruction manual of the light source.

11.2.3.1 Assembling the HXP 120 V Light Source

- Procedure**
1. Place the light source on the table.
 - The front side with the operating and display elements must be freely accessible and visible. **NOTICE** The ventilation slots on the sides and the rear panel of the device must not be covered; a free space of at least of at least 150 mm must be maintained in the area of the ventilation slots.
 2. Connect the plug-in power supply to the mains power supply.
 3. Refer to the instruction manual of the HXP 120 V for further installation steps.

11.2.4 LED 10 Light Source

11.2.4.1 Labels on the LED light source

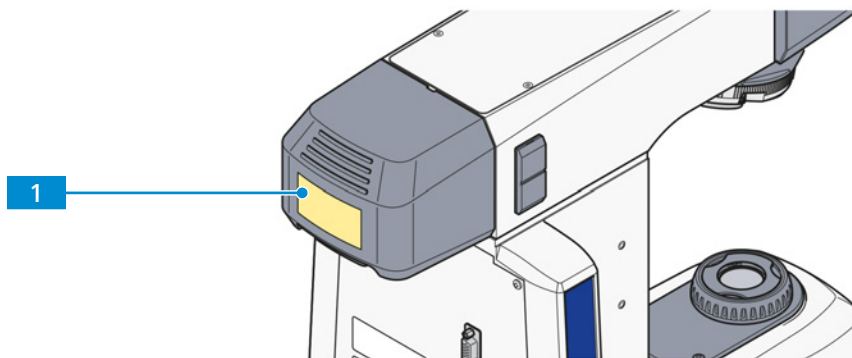



Fig. 53: Position of the warning label on microscopes with LED light source for reflected light

Pos.	Symbol	Description
1	 <div style="border: 1px solid black; padding: 5px; margin-left: 10px;"> <p>CAUTION</p> <p>LED RADIATION</p> <p>Do not stare at operating lamp. May be harmful to the eyes.</p> </div>	<p>CAUTION</p> <p>LED Radiation</p> <p>Do not stare at operating lamp. May be harmful to the eyes.</p>

11.2.4.2 Assembling the LED10 Light Source for Transmitted Light Illumination

⚠ CAUTION

Eye damage or skin irritation due to hazardous light emission

The light source belongs to Risk Group 2 as specified in IEC 62471 and emits optical radiation and UV radiation. Eye damage or skin irritation may result from exposure.

- ▶ Never look directly into the light-emitting aperture of the light source.
- ▶ Avoid exposure of skin to the radiation. Use suitable protective equipment/protective clothing if required.
- ▶ Before installing or removing the light source always make sure it is switched off.

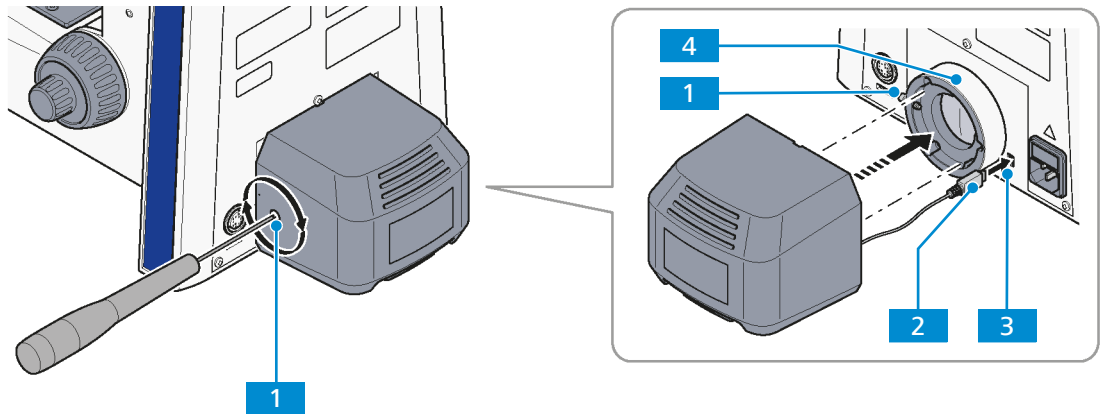

Parts and Tools  Hex key, 3.0 mm

- Prerequisite**
- ✓ The microscope is switched off.
 - ✓ The stand is equipped with the illumination mount.

- Procedure**
1. At the illumination mount on the rear side of the stand, loosen the clamping screw **1**.
 2. Insert the plug **2** of the light source's cable into the socket **3** for transmitted light illumination.
 3. Insert the light source's dovetail ring into the illumination mount **4**.
 4. Ensure that the illumination cable is not being pinched or clamped.
 5. Tighten the clamping screw **1**.

Proceed in the reverse order for removal.

11.2.4.3 Assembling the LED10 Light Source for Reflected Light Illumination

For assembling the LED10 light source for reflected light illumination, proceed in the same way as for the *LED10 light source for transmitted light illumination* [[▶ 145](#)].

11.2.5 Colibri 3 LED Light Source

11.2.5.1 Labels on the Colibri 3

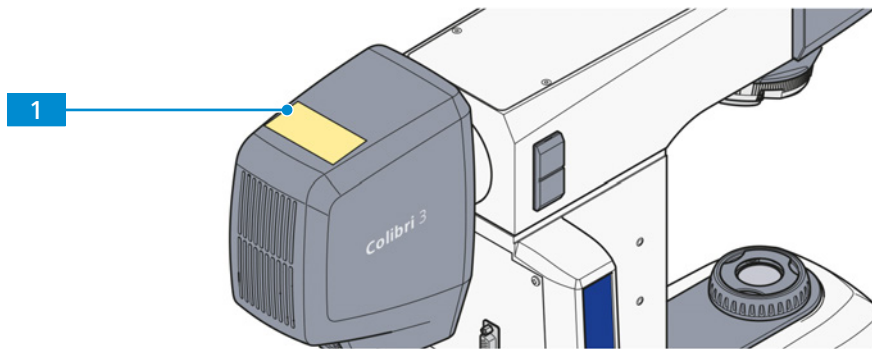

Fig. 54: Warning label on the Colibri 3 light source for reflected light

Pos.	Symbol	Description
1		<p>Risk group 3 according to IEC 62471</p> <p>WARNING: Possibly hazardous optical radiation emitted from this product. Do not look at operating lamp. Eye injury may result.</p> <p>WARNING: UV emitted from this product. Avoid eye and skin exposure to unshielded product.</p>

11.2.5.2 Assembling the Colibri 3 LED Light Source

⚠ WARNING

Skin or eye injury due to hazardous light emission

The light source belongs to Risk Group 3 as specified in IEC 62471 and emits LED radiation and UV radiation. Skin or eye injury can result from the exposure.

- ▶ Avoid any eye and skin exposure to the light-emitting aperture of the light source.
- ▶ Avoid exposure of skin to the radiation. Use suitable protective equipment/protective clothing if required.
- ▶ Before installing or removing the light source always make sure it is switched off.

Info

Further information on installing the light source is available in the supplied instruction manual.

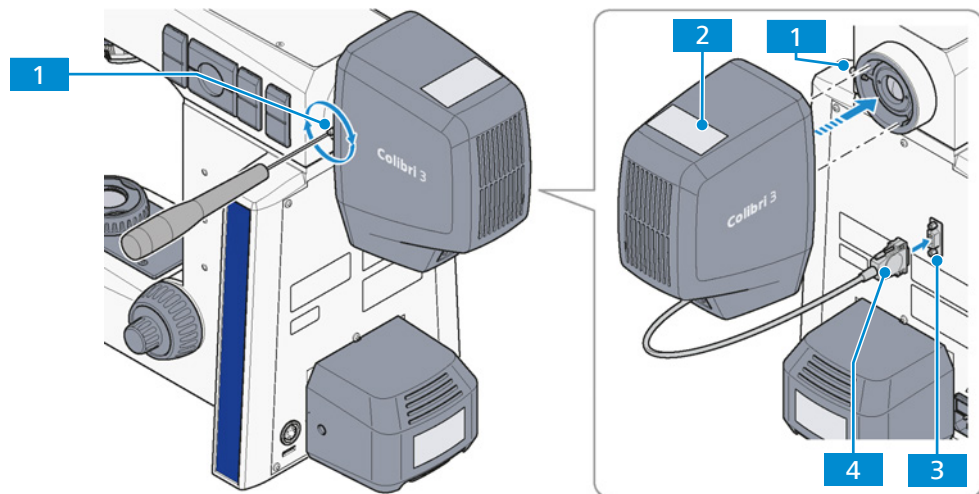

Parts and Tools 🔧 Hex key, 3.0 mm

- Prerequisite**
- ✓ The microscope is switched off.
 - ✓ The Colibri 3 LED light source is switched off.
 - ✓ The stand is equipped with the illumination mount.
 - ✓ The protective cap is removed from the illumination mount.

- Procedure**
1. At the illumination mount on the rear side of the stand, loosen the clamping screw **1**.
 2. Insert the LED light source **2** with the dovetail ring into the illumination mount.
 3. Tighten the clamping screw.
 4. Connect the LED light source plug **4** to the stand socket **3**.
 5. Tighten the fixing screws on the plug.

Proceed in the reverse order for removal.

11.2.5.3 Exchanging the LED Modules of the Colibri 3 LED Light Source

⚠ WARNING

Skin or eye injury due to hazardous light emission

The light source belongs to Risk Group 3 as specified in IEC 62471 and emits LED radiation and UV radiation. Skin or eye injury can result from the exposure.

- ▶ Avoid any eye and skin exposure to the light-emitting aperture of the light source.
- ▶ Avoid exposure of skin to the radiation. Use suitable protective equipment/protective clothing if required.
- ▶ Before installing or removing the light source always make sure it is switched off.

For more information about the usability of LED modules for Colibri 3, see *Usability of LED Modules for the Colibri 3 LED Light Source* [▶ 122].

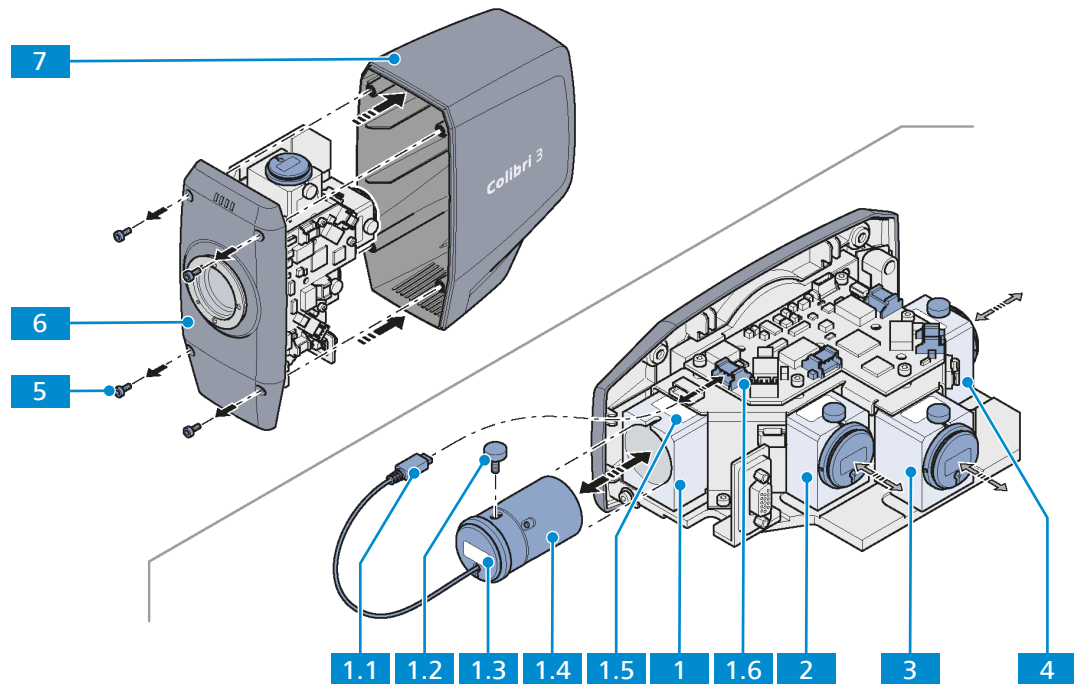

Parts and Tools 🔧 Hex key, 3.0 mm

- Prerequisite**
- ✓ The microscope is switched off.
 - ✓ The plug of the light source's cable has been removed from the corresponding socket.
 - ✓ The Colibri 3 light source is removed from the microscope.

- Procedure**
1. Loosen the four captive screws **5** on the front side **6** of the light source.
 2. Remove the housing **7**.
 3. Disconnect the LED module power cable connector **1.1** from the PCBA **1.6**.
 4. Loosen the knurled screw **1.2**.
 5. Remove the old LED module **1.4**.
 6. Select the LED module with matching LED-specific labels **1.3** and **1.5**.
 7. Insert the LED module in the correct slot.
 8. Connect the LED module power cable connector to the PCBA.
 9. If required, replace the LED modules of LED slots **2**, **3**, and **4** in the same way.
 10. Re-mount the housing.

11.2.6 Viluma 5/7

The Viluma 5/7 is an LED-based light source for reflected-light fluorescence microscopy applications.

Info

For further information, refer to the instruction manual of the light source.

11.2.6.1 Labels on the Viluma 5 or Viluma 7

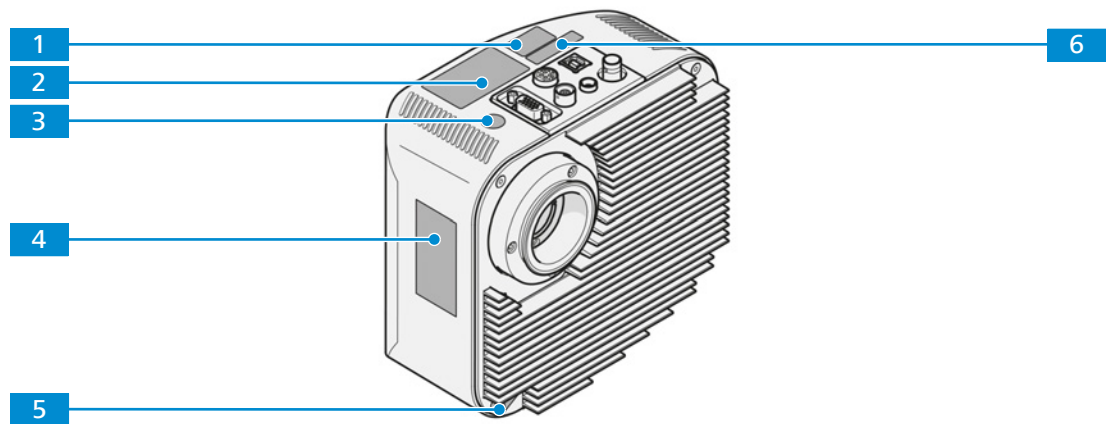



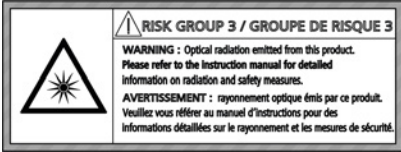

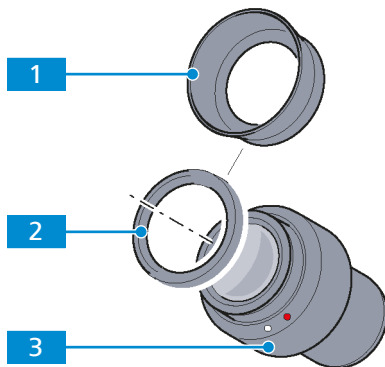

Fig. 55: Labels on the Viluma 5 or Viluma 7 LED light source

Pos.	Label	Explanation
1		CSA label
2		Type label
3		Observe instructions for use.

Pos.	Label	Explanation
4		<p>Optical radiation warning label</p> <p>WARNING UV emitted from this product. Avoid eye and skin exposure to unshielded product.</p> <p>WARNING Possibly hazardous optical radiation emitted from this product. Do not look at operating lamp. Eye injury may result.</p> <p>CAUTION Possibly hazardous optical radiation emitted from this product. Do not stare at operating lamp. May be harmful to the eyes.</p>
5		<p>Hot surface!</p> <p>Do not touch.</p>
6		<p>Patent label (only valid for Viluma 7)</p>

11.3 Assembling the Reversible Eyecups



- Procedure**
1. Remove the eyeglass protection ring **2** from the eyepiece **3**.
 2. Mount the reversible eyecup **1**.

Sometimes the eyeglass protection rings are seated very tightly in the eyepiece groove, so you may need a blunt sample (wooden stick) to prod them off.

11.4 Analyzer Sliders

11.4.1 Analyzer Slider TL/RL, Fixed

Purpose The analyzer slider is used to set the polarization contrast technique.

Position The analyzer slider is inserted into the 12x46 slot of the intermediate plate for analyzer slider 12x46 mounted between stand and tube.

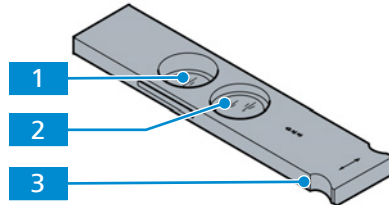

Fig. 56: Analyzer slider TL/RL, fixed

- | | |
|-------------------------|-------------------|
| 1 Empty position | 2 Analyzer |
| 3 Handle | |

11.4.2 Analyzer Slider TL/RL, with Lambda Plate, 360° Rotatable

Purpose The analyzer slider is used to set the polarization contrast technique.

Position The analyzer slider is inserted into the 12x46 slot of the intermediate plate for analyzer slider 12x46 mounted between stand and tube.

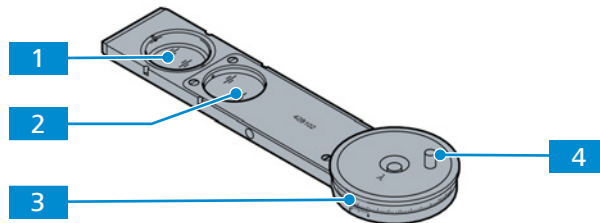

Fig. 57: Analyzer slider TL/RL, with lambda plate, 360° rotatable

- | | |
|-------------------------|--|
| 1 Empty position | 2 Analyzer and lambda plate |
| 3 Angle scale | 4 Handle to rotate the lambda plate |

11.4.3 Analyzer Slider TL/RL with Lambda Plate, each Rotatable +/- 10°

Purpose The analyzer slider is used to set the polarization contrast technique.

Position The analyzer slider is inserted into the 12x46 slot of the intermediate plate for analyzer slider 12x46 mounted between stand and tube.

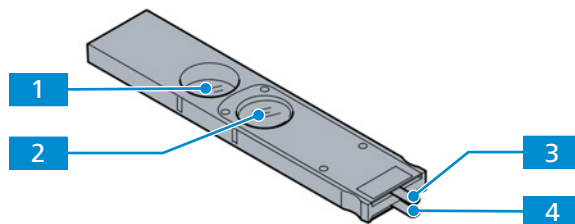

Fig. 58: Analyzer slider TL/RL with lambda plate, each rotatable +/- 10°

- | | |
|--|--|
| 1 Empty position | 2 Analyzer and lambda plate |
| 3 Handle for adjusting the lambda plate | 4 Handle for adjusting the analyzer |

11.5 DIC Slider C 6x20

- Purpose** The DIC slider is used to set the DIC contrast technique.
- Position** The DIC slider is inserted into the 6x20 slot above the nosepiece. The DIC slider is available in two versions:
- DIC Slider C 6x20 for objectives EC Epiplan 5x - 20x
 - DIC Slider C 6x20 for objectives EC Epiplan 50x - 100x

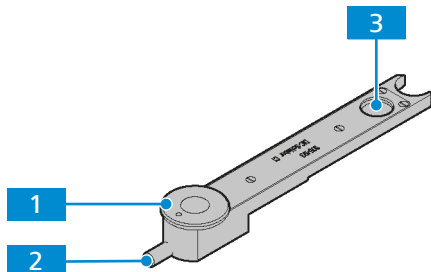

Fig. 59: DIC Slider C 6x20

- | | |
|------------------------|------------------------|
| 1 Setting wheel | 2 Setting screw |
| 3 DIC prism | |

11.6 Stop Sliders for Aperture and Luminous-Field Diaphragms

- Purpose** The stop sliders serve to adjust the reflected light beam path.
- Position** The stop sliders are mounted in the slots F and A of the upper part of the stand for reflected light.
- Function** One stop slider is required to function as a luminous-field diaphragm (F) and the other to function as the aperture diaphragm (A).

Info

When using fluorescent light, an FL attenuator (if not pre-installed) can be used instead of the aperture diaphragm to attenuate the excitation intensity.

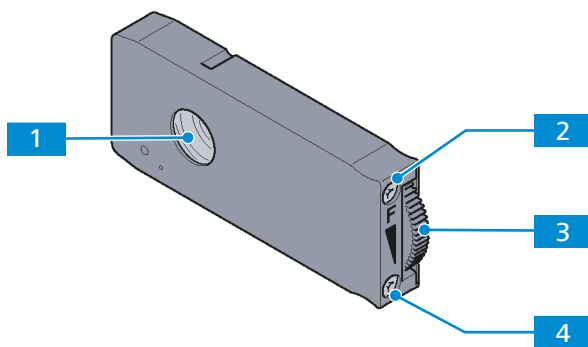

Fig. 60: 14x40 mm stop slider

- | | |
|--|--------------------------|
| 1 Diaphragm | 2 Centering screw |
| 3 Knurled wheel to open/close the diaphragm | 4 Centering screw |

11.7 Stages

A stage is a platform at right angles to the optical axis of the microscope, which carries the sample and which is often fitted with mechanical movements (as in a mechanical stage) to allow easy positioning of the object in the x- and y-axis, and movement along, and rotation about the z-axis.

11.7.1 Mechanical Stage, 75x50/240° Rotatable

Purpose Mechanical stages are used for fixing and positioning the sample for examination.

Position The mechanical stages are mounted on the stage carrier of the stand.

Function The sample is fixed on the stage by means of the sample holder. For this purpose, the sample holder is equipped with a spring lever.

The sample is positioned in the beam path by means of the two coaxial drives in x and y direction. The adjustment range can be read off the respective vernier scale.

The following features and controls are available:

- 240° rotatable with clamping function
- coaxial drives in X and Y adjustment on the right, drive length 160 mm
- travel range 75 x 50mm
- with hardcoat anodized surface

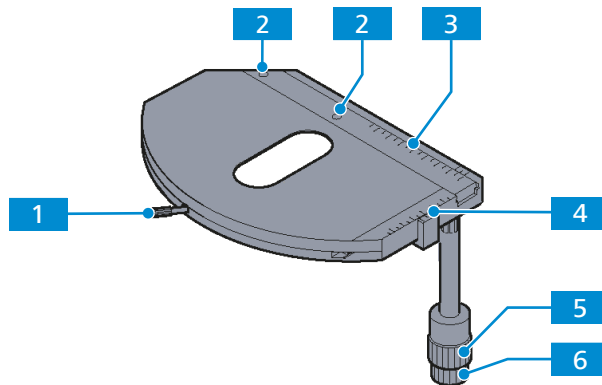
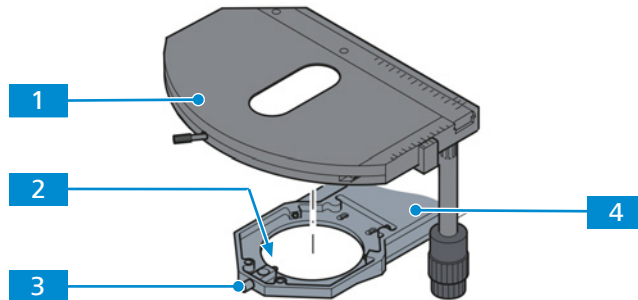

Fig. 61: Mechanical stage, 75x50/240° R

- | | |
|---|--|
| 1 Knurled screw for clamping the stage rotation | 2 Threaded holes (2x) for fixing the sample holder to the stage |
| 3 Vernier scale for display of the adjustment range in X | 4 Vernier scale for display of the adjustment range in Y |
| 5 Coaxial knurled knob for Y adjustment | 6 Coaxial knurled knob for X adjustment |

11.7.1.1 Assembling the Rotatable Mechanical Stage



- Procedure**
1. Loosen the screw cap **3** of the spring-loaded pin **2** with approx. 3 turns.
 2. Put the stage **1** with the dovetail ring notch onto the spring pin.
 3. Press the stage forward against the spring-loaded pin and lower its back side into the stage carrier **4**.
 4. Tighten the screw cap.
- Proceed in the reverse order for removal.

11.7.1.2 Centering the Rotatable Mechanical Stage

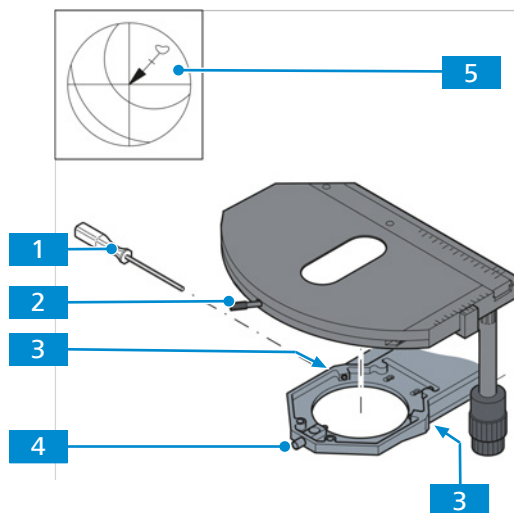

Parts and Tools  Hex key, 1.5 mm

- Prerequisite**
- ✓ The rotary mechanical stage is installed in the stage carrier.
 - ✓ A high-contrast sample and an eyepiece with a crossline reticle are available.
 - ✓ The microscope is adjusted for *transmitted light brightfield microscopy* [[▶ 78](#)].

- Procedure**
1. Loosen the clamping screw **2** of the stage.
 2. Loosen the screw cap **4** of the stage carriers.
 3. Turn the stage, until the maximum shift of the sample **5** (arrow point) to the reticle in the eyepiece is reached.
 4. Turn the two centering screws **3** on the stage carrier, to shift the sample detail half the length of the arrow towards the center of the reticle. Use a 1.5 mm hex key **1**.
 5. Repeat the procedure if the sample detail shifts out of the center again when turning the stage.
 6. Tighten the clamping screw and the screw cap.

11.7.2 Rotary Stage Pol 360° with Clamping Device

Purpose Rotary stages are used for fixing and positioning the sample for examination in polarized light.

Position The rotary stages are mounted on the stage carrier of the stand.

Function The sample is fixed on the stage by means of the clamping device.

The following features and controls are available:

- 360° rotation with lock
- click stop every 45°

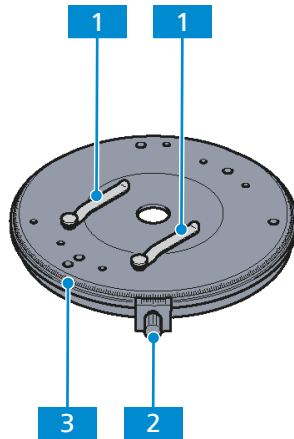

Fig. 62: Rotary Stage Pol 360° with clamping device

1 Clamping device

2 Knurled screw for locking the rotation, 360° rotation possible

3 Angle scale

11.7.2.1 Assembling the Pol Rotary Stage

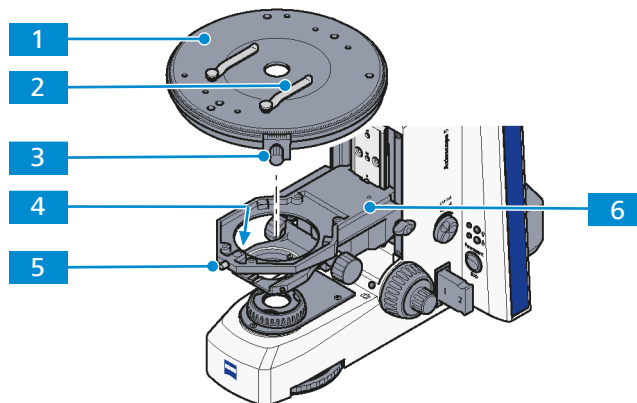

- Procedure**
1. Loosen the screw cap **5** of the spring box with approx. 3 turns.
 2. Put the rotary **1** stage with the dovetail ring notch onto the spring-loaded pin **4**. The knurled screw **3** must point to the front right.
 3. Press the stage forward against the spring-loaded pin and lower it towards the back into the stage carrier **6**.
 4. Tighten the screw cap.
 5. Insert the stage clips of the clamping device **2** into the holes on the stage provided for this purpose.

Proceed in the reverse order for removal.

11.7.2.2 Centering the Pol Rotary Stage

All stages are factory-pre-centered, i.e. when rotating the stage the sample feature set to the center of the field of view will remain in the center. If the sample feature moves off the center of the field of view while rotating the stage, the stage should be re-centered as follows.

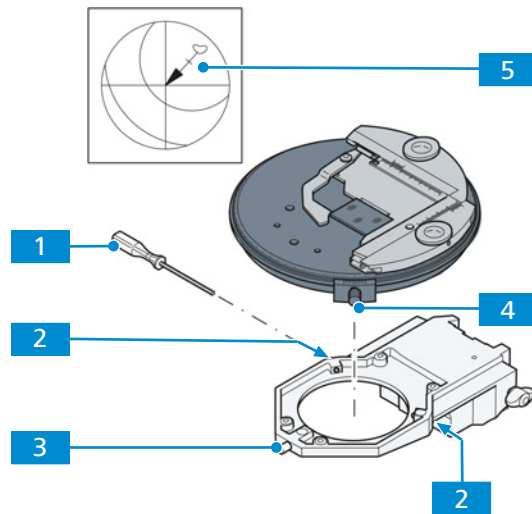

Parts and Tools  Hex key, 1.5 mm

- Prerequisite**
- ✓ The rotary stage is installed in the stage carrier.
 - ✓ The *KÖHLER illumination* [[▶ 78](#)] is adjusted.
 - ✓ A high-contrast sample and an eyepiece with a crossline reticle are available.

- Procedure**
1. Loosen the knurled screw for locking the rotation **4**.
 2. Unscrew the stage carrier cap **2**.
 3. Rotate the stage to determine the position of maximum offset of the sample feature from the center of the eyepiece reticle.
 4. Turn the two centering screws **4** on the stage carrier to move the sample feature **5** by half the arrow length towards the reticle center. Use a 1.5 mm hex key **1**.
 5. Rotate the stage again to check if the sample feature moves off.
 6. Repeat the centering procedure, if necessary.
 7. Tighten the screw cap.

11.7.3 Adjusting the Drive Length on the Stage Drive

Purpose On mechanical stages with ergo-drive, the length of the x and y stage drive can be extended by max. 15 mm by axial movement of the drive knobs to further improve operating ease.

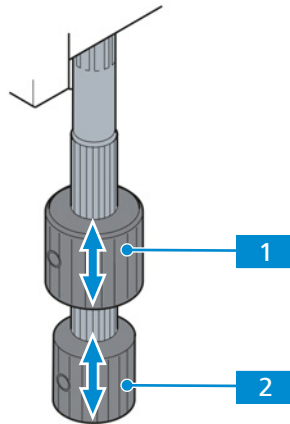

- Procedure**
1. Shift or lower the coaxial knurled knob **1** for the y adjustment within a range of approx. 15 mm.
 2. Shift or lower the coaxial knurled knob **2** for the x adjustment within a range of approx. 15 mm.

11.7.4 Removing the Additional Sleeves on the Ergonomic Stage Drive

Both coaxial knurled knobs for the stages are equipped with additional sleeves for an even more sensitive adjustment of the sample position. These sleeves can be removed when a faster sample movement is important.

- Procedure**
1. Loosen both clamping screws **6** on the lower additional sleeve **5**.

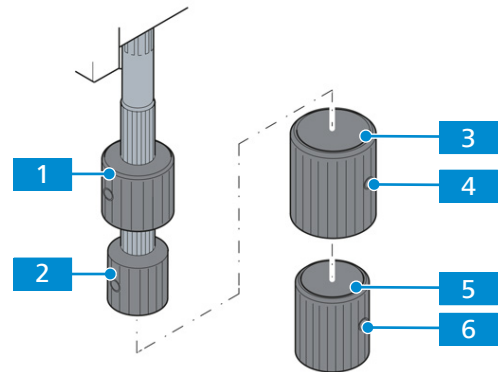

2. Remove the lower additional sleeve **5** from the x coaxial knurled knob **2** by pulling it down.
3. Loosen both clamping screws **4** on the upper additional sleeve **3**.
4. Remove the upper additional sleeve **3** from the y coaxial knurled knob **1** by pulling it down.

Proceed in the reverse order for installing.

11.7.5 Adjusting the Friction of the Coaxial Knurled Knobs on the Stage Drive

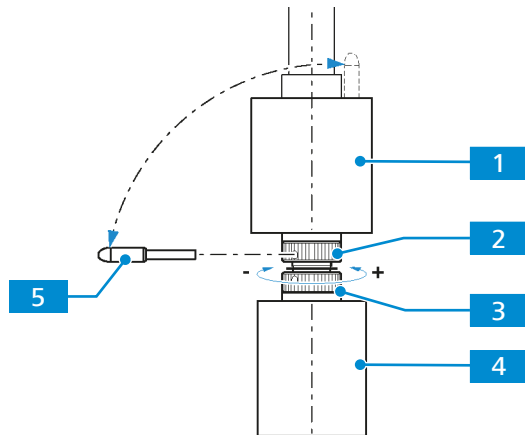

X drive

- Procedure**
1. Push the coaxial knurled knob for the X adjustment **4** all the way to the bottom.
 2. Remove the supplied adjusting pin **5** from the coaxial knurled knob for the Y adjustment **1**.
 3. Insert it into one of the holes of the lower hole nut **3**.
 4. Hold the coaxial knurled knob for the X adjustment **4** and turn the hole nut with the adjusting pin clockwise or counter-clockwise until the desired freedom of movement has been achieved.
 - Small friction adjustment: – (clockwise)
 - Large friction adjustment: + (counter-clockwise)
 - It should not be shifted more than one revolution.

Y drive

- Procedure**
1. Push the coaxial knurled knob for the Y adjustment **1** all the way to the top.
 2. Insert the supplied adjusting pin **5** into the hole of the upper hole nut **2**.
 3. Hold the coaxial knurled knob for the Y adjustment **1** and turn the hole nut with the adjusting pin clockwise or counter-clockwise until the desired freedom of movement has been achieved.
 - Small friction adjustment: – (clockwise)
 - Large friction adjustment: + (counter-clockwise)
 - It should not be shifted more than one revolution.
 4. Re-insert the adjusting pin into the coaxial knurled knob for the Y adjustment.

11.7.6 Adjusting the Friction of the Coaxial Knurled Knobs on the Ergonomic Stage Drive

The smoothness of the ergonomic operation is factory pre-set to a medium level. Depending on the installed stage, the operator can change it as follows:

X drive

- Prerequisite** ✓ The additional sleeves are *removed* [▶ 157].

- Procedure**
1. Shift the x coaxial knurled knob **4** downward and the y coaxial knurled knob **2** upward.

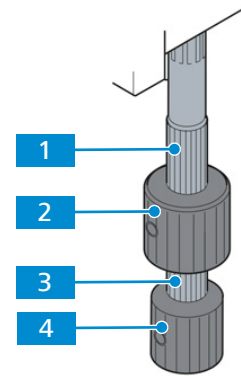

2. Hold the x coaxial knurled knob **4** and turn the light-colored knurled ring above it **3** to the right (increased smoothness) or left (decreased smoothness) until you reach the desired level.

Y drive

- Procedure**
1. Hold the y coaxial knurled knob **2** and turn the light-colored knurled sleeve above it **1** to the right (increased smoothness) or the left (decreased smoothness) until you reach the desired level.

11.8 Loading the Reflector Module

11.8.1 Assembling Reflector Modules

To ease the use and the recovery of reflector modules, the modules should be installed to defined positions. The insert positions' numeric markings can be used to identify the modules.

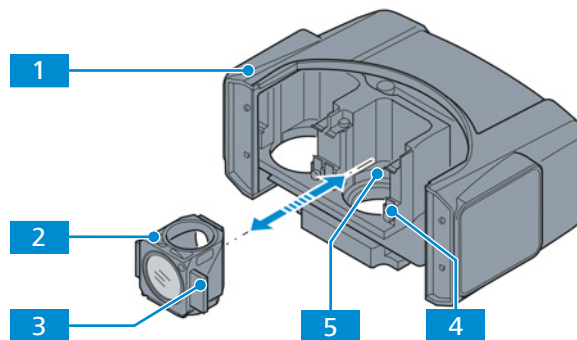

- Procedure**
1. Remove the *reflector insert* [▶ 68] **1** from the upper part of the stand.
 2. Put the reflector insert aside with the top side facing down.
 3. **NOTICE Avoid touching optical surfaces.** Carefully insert the module **2** (with the top side facing down) with the aid of its retaining brackets **3** at a slant from the top into the lower spring clips **4**.
 4. Press the module against the upper spring clips **5** of the reflector insert until it engages firmly.
 5. Install the reflector insert.

Proceed in the reverse order for removal.

11.8.2 Exchanging the Filters of the Reflector Module FL P&C

NOTICE

Sensitive equipment

Changing the optical parts of a reflector module without damage requires considerable skills and utmost care.

- ▶ If possible, use fully equipped reflector modules provided by ZEISS.
- ▶ Take maximum care not to damage any optical or mechanical part when equipping a reflector module.

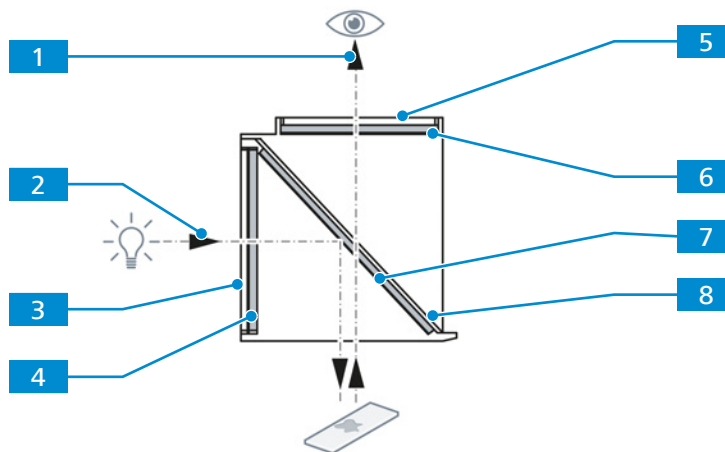

Fig. 63: Mounting the filters and the beam splitter

- | | | | |
|----------|---|----------|---|
| 1 | Path of the imaging beam | 2 | Path of the illumination beam |
| 3 | Reflective coating of the excitation filter | 4 | Excitation filter |
| 5 | Emission filter | 6 | Reflective coating of the emission filter |
| 7 | Reflective coating of the beam splitter | 8 | Beam splitter |

Note the following orientation rules:

- **Emission filters** **5** should be installed with the reflective coating pointing to the inside of the reflector module.
- **Emission filters** **5** with a direction indicating arrow on their circumference must be installed with the arrow pointing to the inside of the reflector module.
- **Emission filters** **5** with a label indicating the wedge angle must be installed such that the label points to the reflector module's orientation notch.
- **Excitation filters** **4** should be installed with the reflective coating pointing to the outside of the reflector module.
- **Excitation filters** **4** with a direction indicating arrow on their circumference must be installed with the arrow pointing to the inside of the reflector module.

- Parts and Tools**
- 🔧 Tool set for filter exchange
 - 🧤 Lint-free gloves

- Prerequisite** ✓ The reflector module is removed from the reflector insert.

- Procedure**
1. Unscrew the retaining ring **11** using the mounting plate **9** of the tool set.

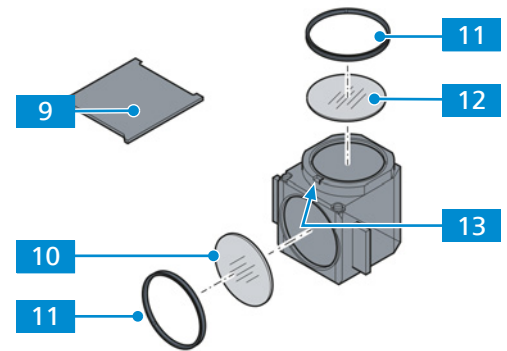

2. **NOTICE** Avoid contact of sensitive optical components to hard surfaces. Turn the reflector module to let the filter slide out onto a soft surface.
3. Carefully grab the filter **10** / **12** to be installed at its circumference.
4. Set the filter into the corresponding position of the reflector module. Observe the correct orientation. Ensure that the coated surface points into the desired direction **13**.
5. Screw in the retaining ring **11**.

11.8.3 Exchanging the Beam Splitter of the Reflector Module FL P&C

NOTICE

Sensitive equipment

Possibility of damage to optical or mechanical parts during the exchange of the beam splitter.

- ▶ If possible, use fully equipped reflector modules provided by ZEISS.
- ▶ Take maximum care not to damage any optical or mechanical part when equipping a reflector module.

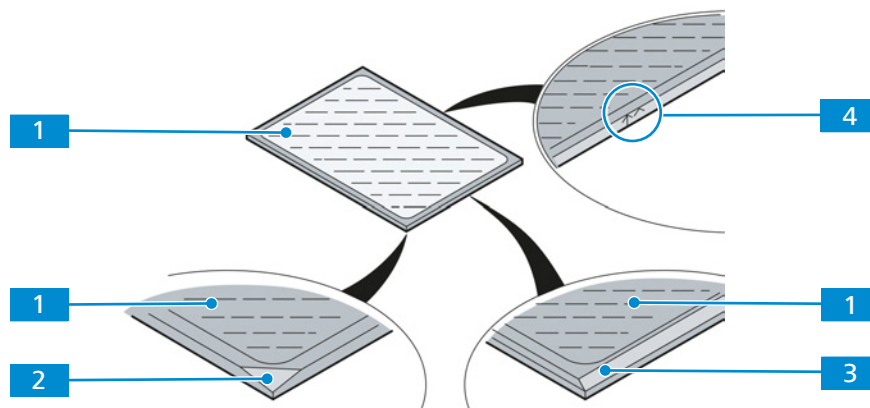



Fig. 64: Labeling of the beam splitter

- | | |
|--|-------------------------|
| 1 Reflective coating of the beam splitter | 2 Beveled corner |
| 3 Beveled edge | 4 Engraving |

Note the following orientation rule:

The reflective coating of the beam splitter **1** should point in the direction of the sample.

The coated side of the beam splitter is marked either by a beveled edge **3**, a beveled corner **2**, or an engraving **4**.

- Parts and Tools**
-  Tweezers
 -  Screwdriver, flat head (small)

Prerequisite ✓ The reflector module is removed from the reflector insert.

Procedure 1. Remove both fixation screws **5**.

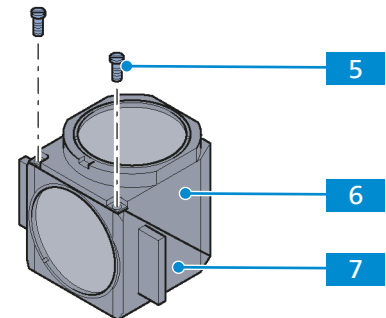

2. Hold both parts of the reflector module (the emission part **6** and the excitation part **7**) together, and turn the entire reflector module upside down, so that the emission filter points downwards.
3. Tilt the excitation part **7** upwards and carefully move it to the module's back, so it is released from the retaining pins **11** of the emission part.

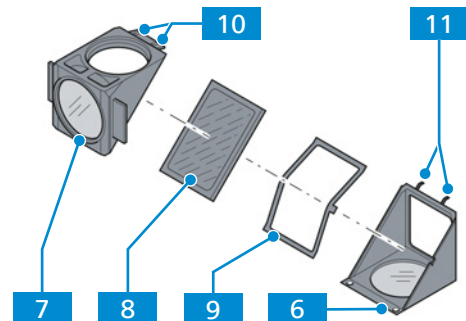

→ You are facing the beam splitter **8**.

4. Remove the beam splitter and the spring-loaded frame **9** from the emission part.
5. Remove the beam splitter from the spring-loaded frame.
6. Position the new beam splitter on the spring-loaded frame with the coated side pointing upwards.
7. Place the frame with the beam splitter on the emission part of the reflector module. Make sure the lateral tab of the spring-loaded frame engages with the notch of the emission part.
8. Carefully place the excitation part on the emission part, hinging the eyelets **10** of the excitation part into the retaining pins **11** of the emission part.
9. Hold both parts of the reflector module together and turn the entire reflector module upside down, so that the emission filter points upwards.
10. Screw in the fixation screws.
11. Attach the adhesive label with the name of the filter combination to the reflector module's side wall.

11.9 Loading the Condenser

11.9.1 Assembling the Modulator Disk in the Condenser 0.9 BF Pol

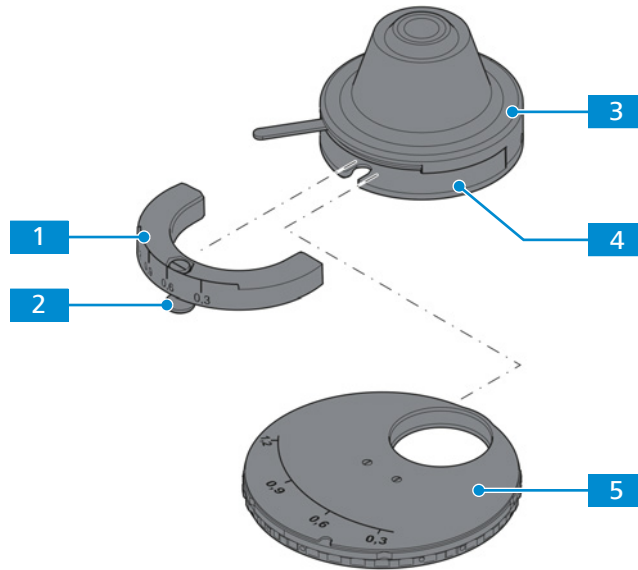

Parts and Tools  Hex key, 3.0 mm

Prerequisite  The condenser **3** is removed from the condenser carrier [[▶ 188](#)].

- Procedure**
1. Loosen the clamping screw **2** of the condenser's dial segment **1** and pull out the dial segment.
 2. Slide the modulator disk **5** with its two-pronged forked opening pointing forward into the condenser opening **4**.
 3. Make sure that the disk engages in the guide on both inner sides of the condenser.
 - The guide serves as a stop for the modulator disk. The pin of the disk's clamping screw must slide into the orientation groove of the condenser.
 4. Tighten the disk's clamping screw.
 5. Replace the condenser in its carrier.

11.9.2 Assembling the Slit-Diaphragm for PlasDIC into the Modulator Disk

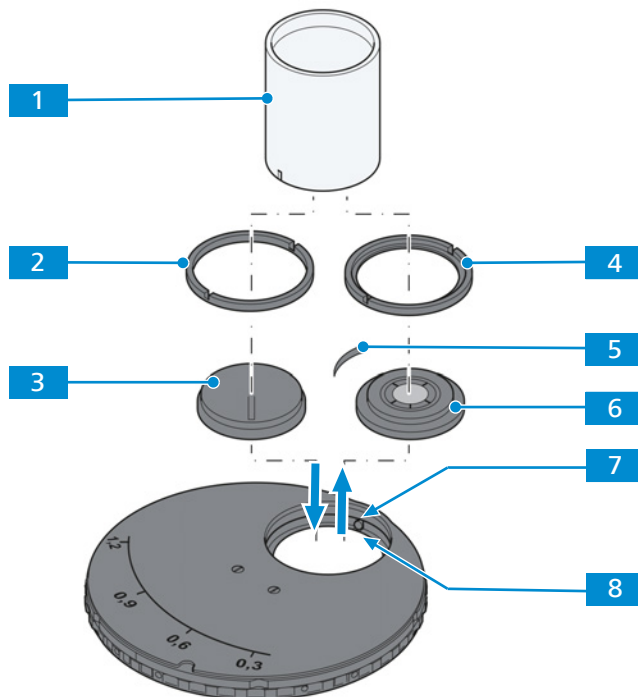

Parts and Tools  Hex key, 1.5 mm

Prerequisite  The modulator disk is removed [[▶ 163](#)].

- Procedure**
1. Turn the PhC diaphragm that needs to be replaced into the free aperture of the modulator disk.
 2. Screw the modulator disk's centering screws **7** back until they stop.
 3. Unscrew the adapter ring **4** of the PhC diaphragm with the included tool **1**.
 4. Remove the PhC diaphragm **6** and the spring **5**.
 5. With the tool, insert the slit-diaphragm for PlasDIC **3** with its cams into the orientation grooves **8**.
 6. With the tool, screw in the adapter ring **2** included with the slit-diaphragm.
- Proceed in the reverse order for removal.

11.9.3 Changing PhC DIC PlasDIC Diaphragms on the 0.9 BF DF PhC DIC Achromatic-Aplanatic Condenser

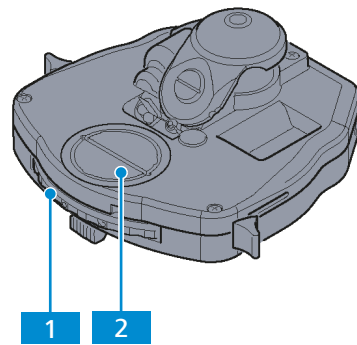

Parts and Tools  Hex key, 1.5 mm

Prerequisite  The condenser is *removed* [[▶ 188](#)].

- Procedure**
1. Remove the cover [2](#).
 2. Turn the modulator disk [1](#) to have access to the corresponding diaphragm position.
 3. Change the appropriate diaphragm, see *Assembling the Slit-Diaphragm for PlasDIC into the Modulator Disk* [[▶ 164](#)].
 4. If a DIC diaphragm has been inserted instead of a PhC diaphragm, the pre-set mechanism that automatically opens the PhC diaphragm must be deactivated. For this, turn the centering screws of the modulator disk counterclockwise to the stop.
 - Now, the aperture diaphragm can be closed for DIC contrast techniques.

11.10 Assembling the Sample Space Extension, 60 mm

Info

Pure transmitted light stands have no reflector turret sensor / RL LED interface. Accordingly, no connection cables for this purpose are installed.

The following action comprises several action sequences. These sequences are to be carried out in the specified order.

1. *Removing the cover of the upper part of the stand* [[▶ 166](#)]
2. *Disconnecting the cable connections* [[▶ 166](#)]
3. *Removing the upper part of the stand* [[▶ 167](#)]
4. *Assembling the sample space extension* [[▶ 167](#)]
5. *Assembling the upper part of the stand on the sample space extension* [[▶ 168](#)]
6. *Establishing the cable connections* [[▶ 168](#)]
7. *Assembling the cover of the upper part of the stand* [[▶ 169](#)]

11.10.1 Removing the Cover of the Upper Part of the Stand

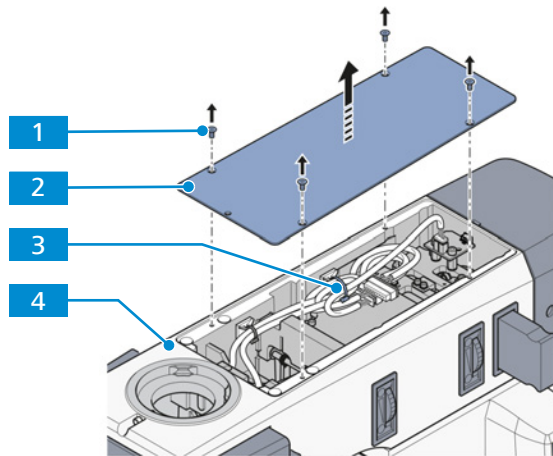

Prerequisite ✓ The binocular tube is removed [▶ 65].

- Procedure**
1. Unscrew the 4 screws **1**.
 2. Remove the cover **2** from the upper part of the stand **4**.
 3. Cut and remove one cable tie **3**.

11.10.2 Disconnecting the Cable Connections

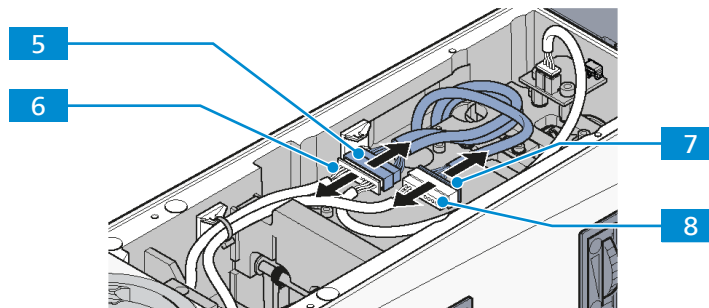

- Procedure**
1. Disconnect the cable connection between the main control board **3** of the lower part of the stand and the nosepiece sensor of the upper part of the stand **4**.
 2. Disconnect the cable connection between the main control board **1** and the turret sensor / RL LED interface **2**.

11.10.3 Removing the Upper Part of the Stand

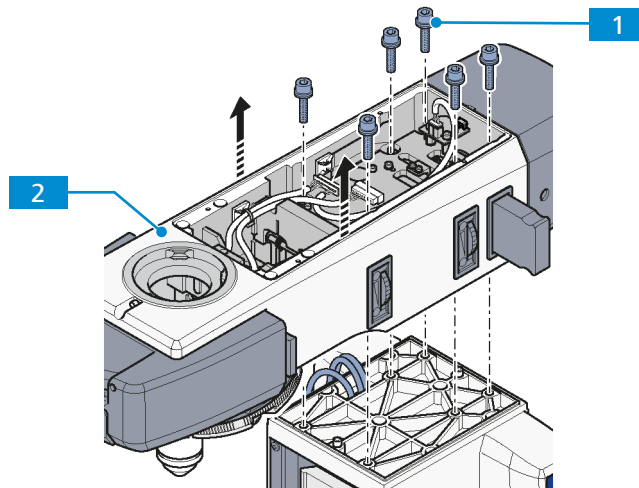

- Procedure**
1. Unscrew 6 fixing screws **1**, holding the upper part of the stand **2**.
 2. Carefully remove the upper part of the stand while pulling the cables downwards out of the upper part of the stand.

11.10.4 Assembling the Sample Space Extension

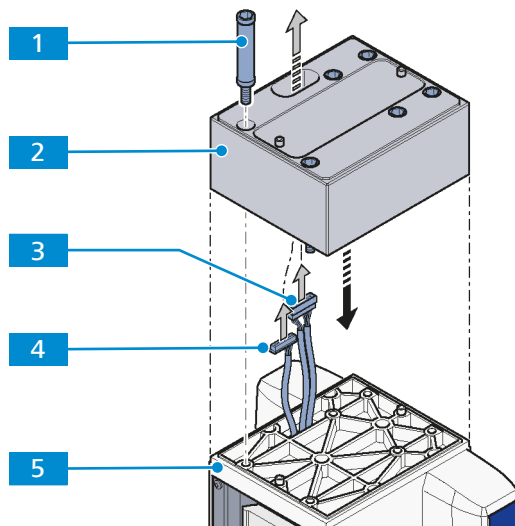

- Procedure**
1. Carefully route the cables **3** and **4** from below through the long hole of the sample space extension **2**.
 2. Place the sample space extension on the lower part of the stand **5**.
 3. Tighten the sample space extension with its 6 spacer bolts **1**.

11.10.5 Assembling the Upper Part of the Stand on the Sample Space Extension

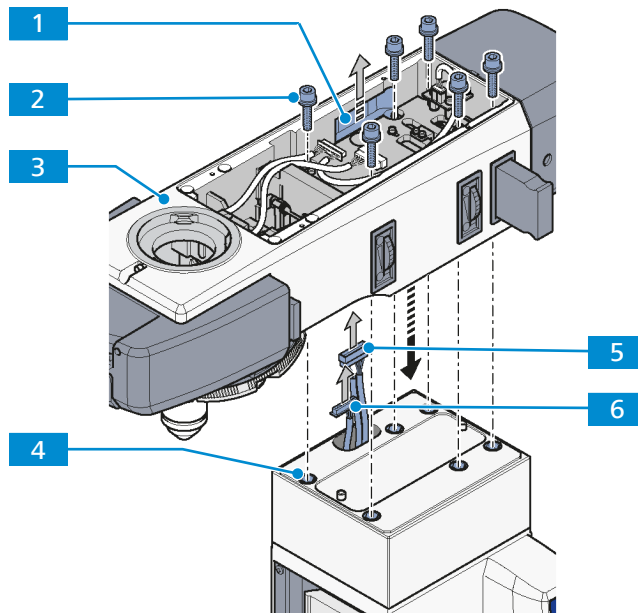

- Procedure**
1. Carefully route the cables **5** and **6** from below through the lateral opening **1** of the upper part of the stand **3**.
 2. Place the upper part of the stand on the sample space extension **4**.
 3. Tighten the upper part of the stand with 6 fixing screws **2**.

11.10.6 Establishing the Cable Connections

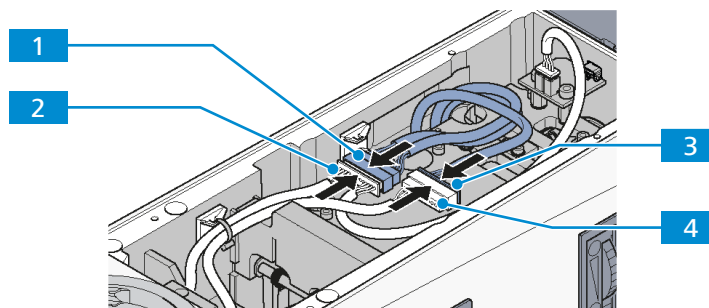

- Procedure**
1. Establish the cable connection between the main control board **3** of the lower part of the stand and the nosepiece sensor of the upper part of the stand **4**.
 2. Establish the cable connection between the main control board **1** and the turret sensor / RL LED interface **2**.
 3. Make sure the plugs are securely connected.

11.10.7 Assembling the Cover of the Upper Part of the Stand

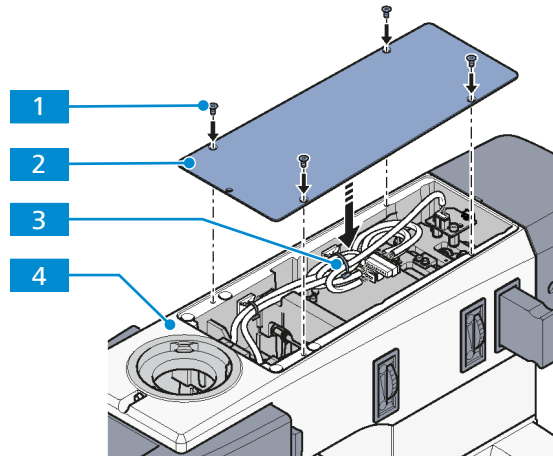

- Procedure**
1. Secure the cables with a cable tie **3**.
 2. Place the cover **2** on the upper part of the stand **4**.
 3. Screw in and tighten the 4 screws **1**.
 4. *Install the binocular tube [▶ 65].*

11.11 Polarizers

11.11.1 Polarizer D, Fixed, Removable

Purpose The polarizer for transmitted light is used to polarize the light of the transmitted light source. The polarizer can be swivelled into or out of the beam path using the handle.

Position The polarizer is mounted on the bottom of the *condenser carrier* [▶ 174].

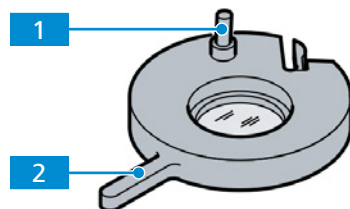

Fig. 65: Polarizer D, fixed, removable

1 Detent bolt

2 Handle of the polarizer for swivelling in/out

11.11.2 Polarizer, Fixed, W-E $\pm 10^\circ$ adj.

Purpose The polarizer for transmitted light is used to polarize the light of the transmitted light source. The direction of linear polarization can be adjusted by $\pm 10^\circ$. The polarizer can be swivelled into or out of the beam path using the handle.

Position The polarizer is mounted on the bottom of the *condenser carrier* [▶ 174].

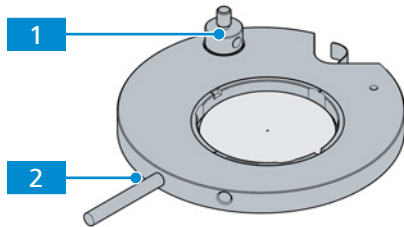

Fig. 66: Polarizer, fixed, W-E $\pm 10^\circ$ adj.

1 Detent bolt

2 Handle of the polarizer for swivelling in/out

11.11.3 Polarizer D, 90°, Rotatable, Removable

Purpose The polarizer for transmitted light is used to polarize the light of the transmitted light source. The polarizer can be swivelled into or out of the beam path using the handle.

Position The polarizer is mounted on the bottom of the *condenser carrier* [▶ 174].

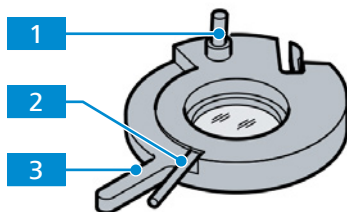

Fig. 67: Polarizer D, 90°, rotatable, removable

1 Detent bolt

2 Lever for rotating the polarizer

3 Handle of the polarizer for swivelling in/out

4 Adapter plate

11.11.4 Polarizer, 90°, W-E $\pm 10^\circ$ adj.

Purpose The polarizer for transmitted light is used to polarize the light of the transmitted light source. The direction of linear polarization can be adjusted by $\pm 10^\circ$. The polarizer can be swivelled into or out of the beam path using the handle.

Position The polarizer is mounted on the bottom of the *condenser carrier* [▶ 174].

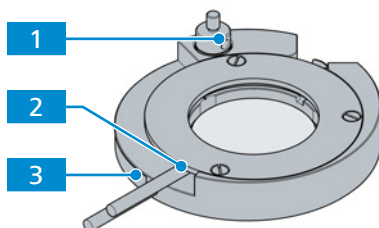

Fig. 68: Polarizer, 90°, W-E $\pm 10^\circ$ adj.

1 Detent bolt

2 Lever for rotating the polarizer

3 Handle of the polarizer for swivelling in/out

11.11.5 Polarizer, Fixed, with Lambda Plate, Rotatable

Purpose The polarizer for transmitted light is used to polarize the light of the transmitted light source. The polarizer can be swivelled into or out of the beam path using the handle.

Position The polarizer is mounted on the bottom of the *condenser carrier* [▶ 174].

Polarizer and lambda plate can be swivelled in/out separately.

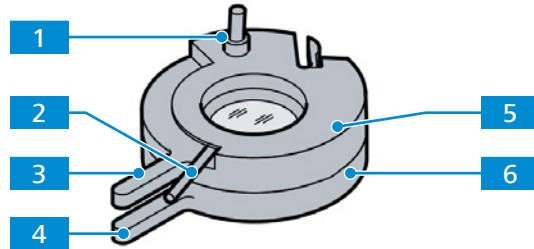

Fig. 69: Polarizer, fixed, with lambda plate, rotatable

- | | |
|---|--|
| 1 Detent bolt | 2 Lever for rotating the lambda plate |
| 3 Handle of the lambda plate for swivelling in/out | 4 Handle of the polarizer for swivelling in/out |
| 5 Adapter plate | 6 Lambda plate, rotatable by 90° |
| 7 Polarizer | |

11.11.6 Polarizer, Rotatable, with Color Filter Carrier

Purpose The polarizer for transmitted light is used to polarize the light of the transmitted light source. With the help of the color filter carrier optical filter elements can be placed in the beam path. The polarizer and the filter carrier can be swivelled into or out of the beam path using the handle.

Position The polarizer with filter carrier is mounted on the bottom of the *condenser carrier* [▶ 174].

Polarizer and filter carrier can be swivelled in/out separately.

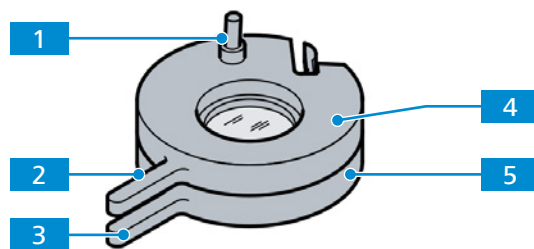

Fig. 70: Polarizer, rotatable, with color filter carrier

- | | |
|---|--|
| 1 Detent bolt | 2 Handle of the polarizer for swivelling in/out |
| 3 Handle of the color filter carrier | 4 Polarizer |
| 5 Color filter carrier | |

11.11.7 Polarizer, 90°,W-E $\pm 10^\circ$ adj.,w. Filter Carrier

Purpose The polarizer for transmitted light is used to polarize the light of the transmitted light source. With the help of the color filter carrier optical filter elements can be placed in the beam path. The direction of linear polarization can be adjusted by $\pm 10^\circ$. The polarizer and the filter carrier can be swivelled into or out of the beam path using the handle.

Position The polarizer is mounted on the bottom of the *condenser carrier* [▶ 174].
Polarizer and filter carrier can be swivelled in/out separately.

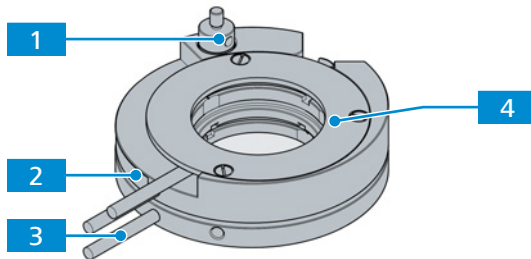

Fig. 71: Polarizer, 90°,W-E $\pm 10^\circ$ adj.,w. filter carrier

- | | |
|---|--|
| 1 Detent bolt | 2 Handle of the polarizer for swivelling in/out |
| 3 Handle of the color filter carrier | 4 Polarizer |

11.11.8 Circular Polarizer D

Purpose The polarizer for transmitted light is used to polarize the light of the transmitted light source. The polarizer can be swivelled into or out of the beam path using the handle.

Position The polarizer is mounted on the bottom of the *condenser carrier* [▶ 174].
Upper part and lower part of the polarizer can be swivelled in/out separately.

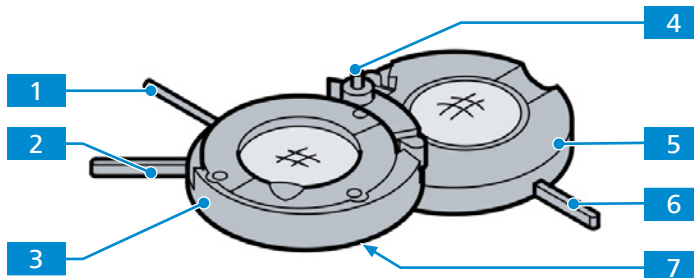

Fig. 72: Circular polarizer D

- | | |
|---|---|
| 1 Lever for rotating the lambda 4/plate, 90° possible | 2 Handle of the upper part of the polarizer for swivelling in/out |
| 3 Lambda/4 plate in the upper part of the circular polarizer | 4 Detent bolt |
| 5 Lower part of the circular polarizer | 6 Handle of the lower part of the circular polarizer for swivelling in/out |
| 7 Adjustment slit (2x) | |

11.11.9 360-degree Rotatable Polarizer

Purpose The polarizer for transmitted light is used to polarize the light of the transmitted light source. The knurled ring allows the user to rotate the polarizer by 360°. The knurled ring is equipped with scale markings at every 15°, and click stops at every 90°. The direction of linear polarization can be adjusted by $\pm 10^\circ$. The polarizer can be swivelled into or out of the beam path.

Position The polarizer is mounted on the bottom of the *condenser carrier* [▶ 174].

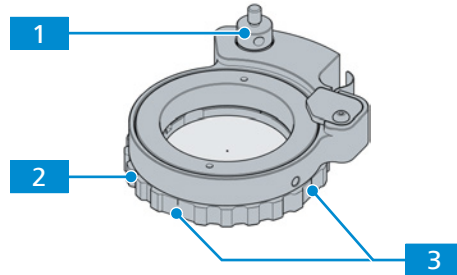

Fig. 73: 360-degree rotatable polarizer

- | | |
|------------------------------|---|
| 1 Detent bolt | 2 Knurled ring with scale markings |
| 3 Click stop position | |

11.11.10 Color Filter Carrier 3x for Filter d=32mm

Purpose With the help of the color filter carrier optical filter elements can be placed in the beam path. The filter carriers can be swivelled into or out of the beam path using the handle.

Position The color filter carrier is mounted on the bottom of the *condenser carrier* [▶ 174]. The three filter carriers can be swivelled in/out separately.

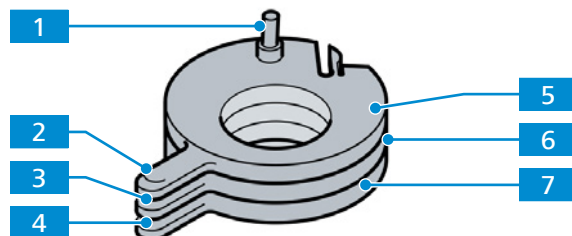

Fig. 74: Color filter carrier 3x for filter d=32mm

- | | |
|--|---|
| 1 Detent bolt | 2 Handle of the first filter carrier for swivelling in/out |
| 3 Handle of the second filter carrier for swivelling in/out | 4 Handle of the third filter carrier for swivelling in/out |
| 5 First filter carrier | 6 Second filter carrier |
| 7 Third filter carrier | |

11.11.11 Installing Polarizer or Color Filter Carrier on the Condenser Carrier

The following components can be installed on the condenser carrier:

- Polarizer D, fixed, removable
- Polarizer, fixed, W-E $\pm 10^\circ$ adj.
- Polarizer D, 90° rotatable, removable
- Polarizer, 90° , W-E $\pm 10^\circ$ adj.
- Polarizer, fixed, with lambda plate, rotatable
- Polarizer, rotatable, with color filter carrier
- Polarizer, 90° , W-E $\pm 10^\circ$ adj., w. filter carrier
- Circular polarizer D
- 360-degree Rotatable Polarizer
- Color filter carrier 3x for filter d=32 mm

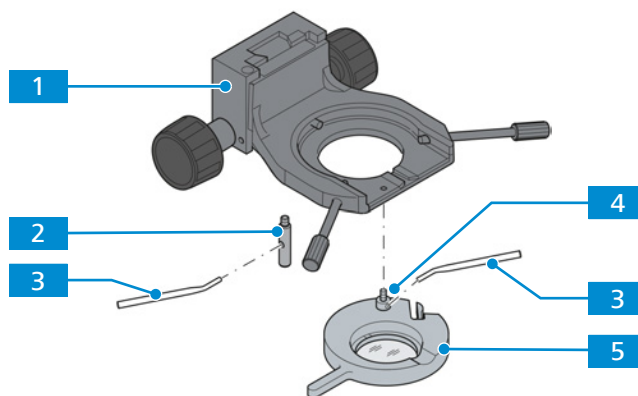

- Prerequisite**
- ✓ The stage carrier with the condenser carrier is *removed* [[▶ 68](#)].
 - ✓ The *low-power system* [[▶ 177](#)] is removed.

- Procedure**
1. Hold the polarizer **5** parallel to the bottom of the condenser carrier **1**.
 2. Insert the holding pin **4** into the front threaded opening at the left below the condenser carrier.
 3. Tighten the holding pin with the adjusting lever **3**.
 4. Screw the locking pin **2** with the adjusting lever into the rear threaded opening of the condenser carrier.

Proceed in the reverse order for removal.

11.11.12 Polarizer on Field Aperture

Purpose The polarizer for transmitted light is used to polarize the light of the transmitted light source. The direction of linear polarization can be adjusted by $\pm 10^\circ$ using the handles.

Position The polarizer is mounted on the *field aperture* [▶ 175].

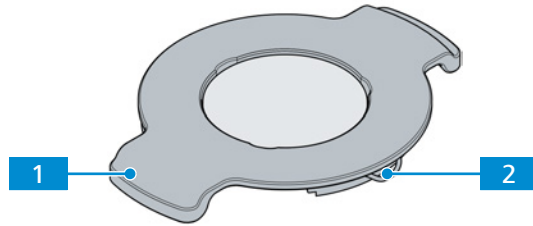

Fig. 75: Polarizer

1 Handle

2 Spring

11.11.13 Installing the Polarizer on the Field Aperture

Prerequisite ✓ Enough space is guaranteed between the condenser carrier and the field aperture.

Procedure 1. Remove the existing black plastic cap on top of the field aperture.

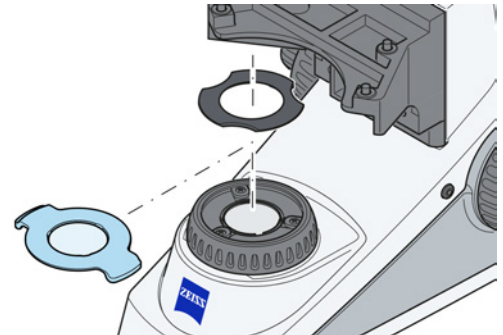

2. Hold the condenser slightly tilted, with the front higher than the back, with the spring facing backward.
3. Press the condenser spring against the rear edge of the field aperture.

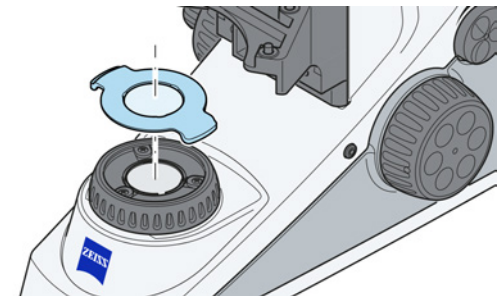

4. Lower the front end of the condenser.
5. Using the thumb, press firmly around the perimeter to ensure a tight installation.

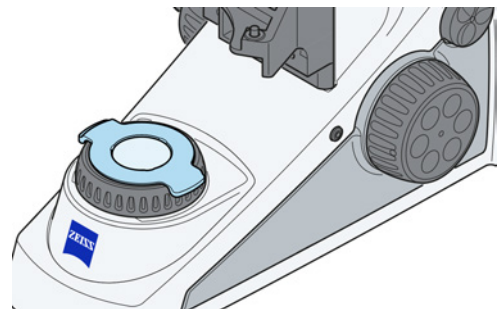

11.11.14 Low-power System for Objectives 2.5x/4x

Purpose The low-power system is for full display field illumination when using an objective with a weak magnification factor (2.5x–4x) in combination with the Condenser 0.9/1.25 H.

Position The low-power system is mounted behind the condenser carrier.

Function It can be centered and remains swivelled into the beam path for as long as the respective objective is in use.

The illumination of weak objective magnifications can be centered with the centering screws. For this purpose, the condenser should be centered on the other objectives without the low-power system.

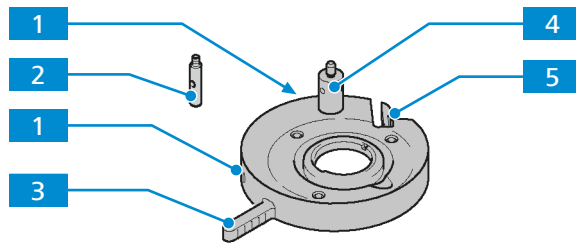

Fig. 76: Low-power system for objectives 2.5x/4x

- | | |
|---|----------------------|
| 1 Centering screw (2x) | 2 Locking pin |
| 3 Handle of the low-power system for swivelling in/out | 4 Holding pin |
| 5 Locking clamp | |

11.11.14.1 Assembling and Centering the Low-power System

Info

The low-power system can be used only in combination with the condenser 0.9/1.25.

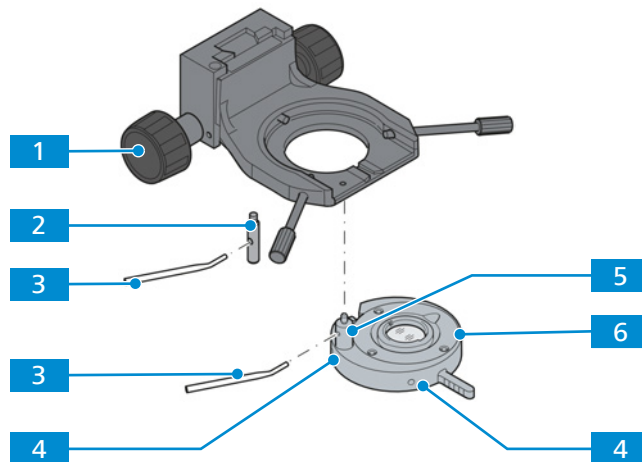

Parts and Tools  2x Hex key, 1.5 mm

Procedure

1. Lift the condenser carrier together with its knurled knob **1** upwards as far as it will go.
2. Hold the low-power system **6** parallel to the underside of the condenser carrier and screw the holding pin **5** of the low-power system with the angled adjusting lever **3** into the front left threaded hole below the condenser carrier as far as it will go.
3. Screw the locking pin **2** with the adjusting lever as far as it will go into the rear threaded hole of the condenser carrier.
4. Swivel the low-power system into the beam path using the handle.
→ Make sure that it is securely engaged.
5. Switch on the microscope.
6. Set transmitted light illumination.
7. Open the aperture diaphragm and luminous-field diaphragm completely.
8. Adjust both adjustment screws **4** until the field of vision is optimally illuminated.

11.12 Assembling the Pol Components

11.12.1 Assembling the Pol Object Guide

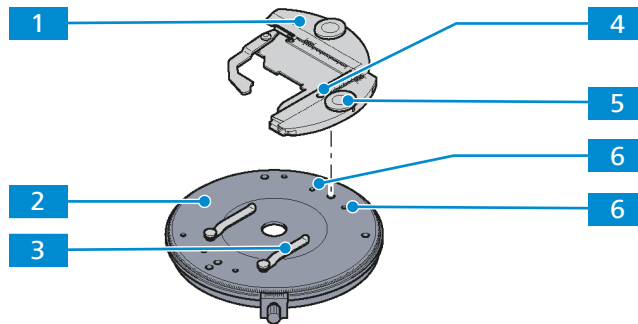

- Procedure**
1. Remove both stage clips of the clamping device **3** from the rotary stage **2**.
 2. Insert the Pol object guide **1**, introducing the two cylindrical pins on its underside into the respective holes **6**.
 3. If required, turn the control wheel **5** until the clamping screw becomes visible in the mounting hole.
 4. Tighten the clamping screw **4**.
- Proceed in the reverse order for removal.

11.12.2 Assembling the Focusable Pol Eyepiece

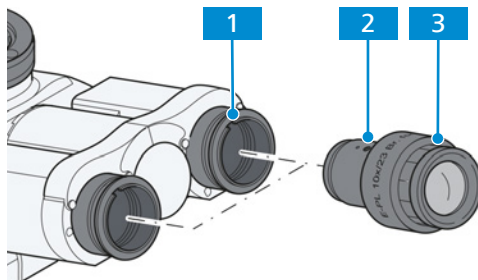

- Procedure**
1. Insert the eyepiece **3** into the binocular photo tube.
 2. Fit the locating screw **2** into the tube's orientation groove **1**.

11.12.3 Centering the Objectives of the Polarization Stand

Stage centering is necessary to ensure that a sample feature located in the center of the field of view does not move out while you are rotating the stage. Centering all objectives ensures that the sample feature remains in the center of the field of view even when the objective is changed.

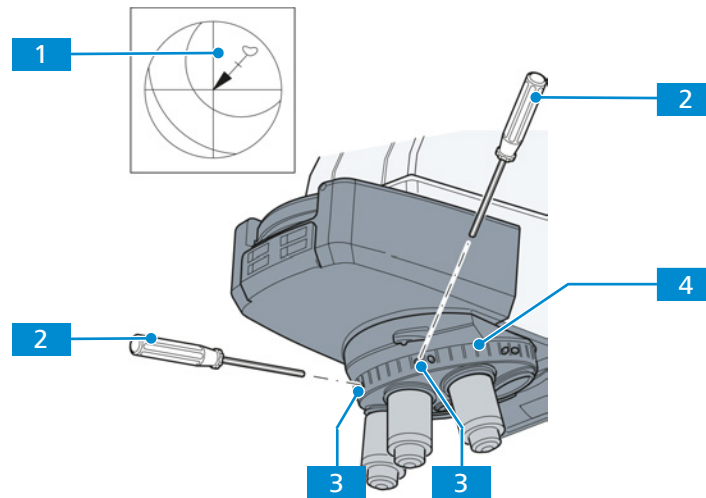

Parts and Tools  Hex key, 1.5 mm

- Prerequisite**
- ✓ The *KÖHLER* illumination [▶ 78] is adjusted.
 - ✓ The *rotary stage is centered* [▶ 156] using the non-centerable objective mount.
 - ✓ A high-contrast sample and an eyepiece with crossline reticle are available.

- Procedure**
1. Turn the nosepiece with the knurled ring **4** to move a centerable objective mount into the light path.
 2. Rotate the stage to determine the position of maximum offset of the sample feature **1** from the center of the eyepiece reticle.
 3. Turn the two centering screws **3** on the nosepiece to move the sample feature by half the arrow length towards the reticle center. Use a 1.5 mm hex key **2**.
 4. Rotate the stage again to check if the sample feature moves off.
 5. Repeat the centering procedure, if necessary.
 6. Repeat the procedure for the other four objectives.

11.13 Axiocam 203 Mono/212 Color

Purpose The camera is used to snap photos or the microscopic image.

Position The Axiocam 203 mono or Axiocam 212 color is mounted on the camera port of the photo tube.

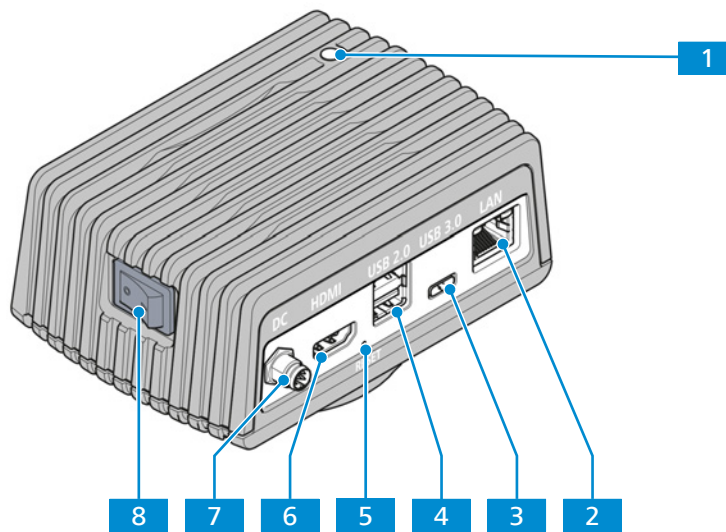
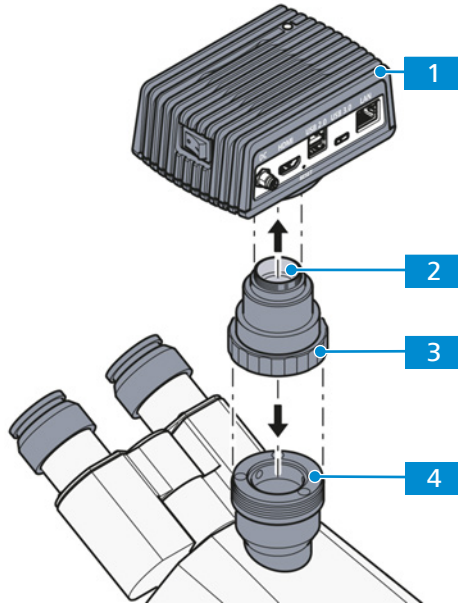

Fig. 77: Axiocam 203 mono/Axiocam 212 color

- | | | | |
|----------|---|----------|--|
| 1 | LED function indicator | 2 | Gigabit Ethernet Port for communication and image data transfer (LAN) |
| 3 | Port for camera control and image transfer (USB 3.0) | 4 | OSD control mouse and keyboard (2x USB 2.0 Type-A) |
| 5 | Camera factory RESET button | 6 | HDMI port for image data transfer to a monitor, TV or projector |
| 7 | DC Port for power supply and communication to the microscope stand | 8 | Power ON / Off switch |

11.13.1 Assembling the Axiocam 203 mono or Axiocam 212 color

- Parts and Tools**
-  C-mount camera adapter
 -  HDMI cable



- Procedure**
1. Mount the C-mount camera adapter **2** on the Axiocam **1**.
 2. Attach the Axiocam with the adapter to the camera port **4** of the tube.
 3. Orient the camera to the stand and fix it in position by tightening the ring nut **3**.
 4. Insert the M8 plug of the Y-cable into the **DC** port of the camera.

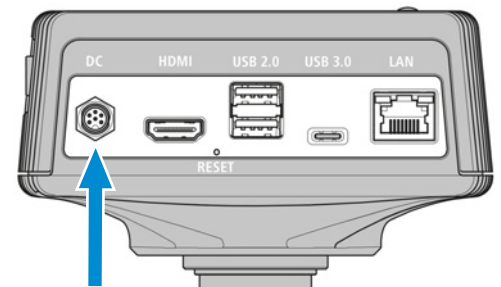

5. Insert the power adapter into a power outlet.

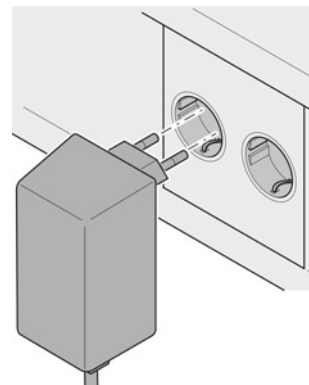

6. Insert the remaining end of the Y-cable into the corresponding socket on the microscope.
7. Connect the camera to an external monitor via an HDMI cable.
8. Alternatively, connect the camera to a WLAN router, USB Type-C drive, or workstation, see also *Operating Modes Using the Axiocam 203 mono/212 color* [[▶ 182](#)].

For additional information, refer to the operating manual of the camera.

11.13.2 Operating Modes Using the AxioCam 203 mono/212 color

11.13.2.1 AxioCam as Standalone System

Purpose The camera is used to capture the microscopic image and store the data on the USB drive connected to the camera.

Function The camera acts as the control interface and is powered by the microscope via the USB (Commercial Micro-D power) cable.

A USB Type-C drive is included in the package and can be connected via the USB slot at the back of the camera for storing data. Then images are recorded and saved to the USB drive.

Functions of the microscope stand such as the Light Manager and encoding are automatically launched. The camera is equipped with image enhancement functions such as true color and noise reduction.

Functionality of the microscope:

- Light Manager
- Coded components
- Image enhancement (true color, noise reduction)
- Record and save images on the USB drive
- Record and save videos on the USB drive

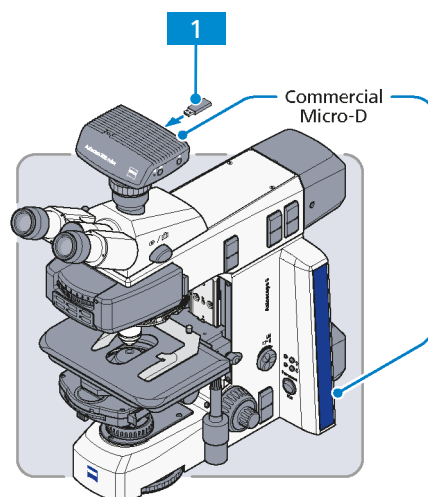

Fig. 78: AxioCam as standalone system

- 1 USB Type-C drive (included in package)

11.13.2.2 Axiocam Connected to an HD Monitor, TV, or Projector

Purpose The camera is used to capture the microscopic image.

Function A monitor can be connected to the camera via an HDMI cable. The camera is powered by the microscope via the USB (Commercial Micro-D power) cable.

A monitor can be connected to the camera of the microscope via an HDMI cable. The camera is powered by the microscope via a USB (Commercial Micro-D power) cable. A USB hub can be connected via the USB port on the camera.

A wireless or wired mouse and keyboard can be connected to the camera via the USB hub, which together with the monitor, function as the control interface. Functions such as the Light Manager, encoding and image enhancement are automatically launched. Live images can be viewed on the monitor display and advanced features are available in the on-screen display (OSD).

When the microscope is operated together with the Colibri 3 light source, the one-key fluorescence function can be used. Images can be snapped and saved on the USB Type-C drive, which is connected via the USB hub.

Functionality of the microscope:

- Light Manager
- Coded components
- Image enhancement (true color, noise reduction)
- Observe live image on display
- Record and save image on the USB drive
- Record and save video on the USB drive
- One-key fluorescence (works only when the Axioscope is used with Colibri 3)
- Advanced features in OSD

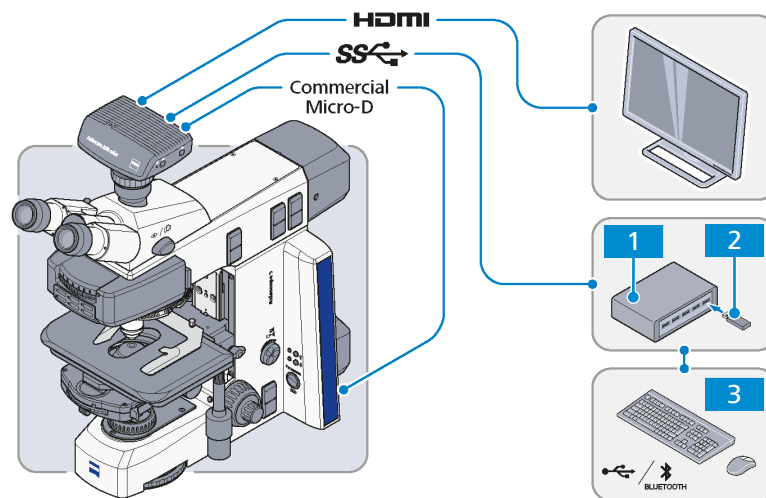

Fig. 79: Axiocam connected to an HD monitor, TV or projector

- 1** USB hub (input type C to output type A) **2** USB Type-C drive provided in package
3 Mouse, keyboard

11.13.2.3 Axiocam Connected with Labscope/Matscope via a Wi-Fi Dongle

Purpose The camera is used to capture the microscopic image.

Function The camera is powered by the microscope via the USB (Commercial Micro-D power) cable.

An optional monitor can be connected to the camera via an HDMI cable.

The recommended USB Wi-Fi dongle can be connected to the camera via the USB hub.

The control interface can be a workstation or portable electronic device that uses Wi-Fi.

Functions such as the Light Manager, encoding, ECO mode and image enhancement are automatically launched.

When a monitor is connected, live images can be viewed on the monitor display. Live images can also be viewed on workstation or portable devices and advanced features in Labscope/Matscope are available.

Functionality of the microscope:

- Light Manager
- Coded components
- ECO mode
- Image enhancement
- Observe live images
- Record and save images via software
- One-key fluorescence (this works only with Axiolab Bio-TL/FL)
- Advanced features in Labscope/Matscope

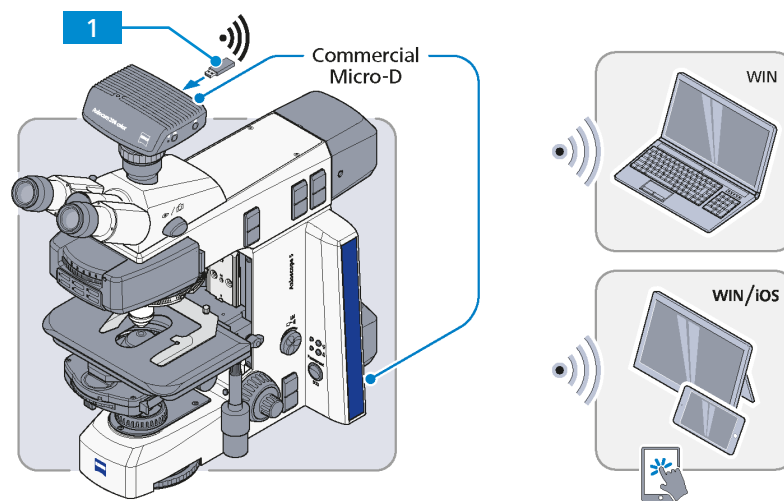

Fig. 80: Axiocam connected with Labscope/Matscope via a Wi-Fi dongle

- 1** USB Wi-Fi dongle (please contact ZEISS Sales & Service Partner)

11.13.2.4 Axiocam Connected with Labscope/Matscope via a WLAN Router

Purpose The camera is used to capture the microscopic image.

Function The camera is powered by the microscope via the USB (Commercial Micro-D power) cable.

An optional monitor can be connected to the camera via an HDMI cable.

A router is connected to the camera via Ethernet.

The control interface can be a workstation or portable electronic device controlled via Ethernet or Wi-Fi.

Functions such as the Light Manager, encoding, ECO mode and image enhancement are automatically launched.

When a monitor is connected, live images can be viewed on the monitor display. Live images can also be viewed on a workstation or a portable device and advanced features in Labscope/Matscope are available.

Functionality of the microscope:

- Light Manager
- Coded components
- ECO mode
- Image enhancement
- Observe live images
- Record and save images via software
- One-key fluorescence (this works only with Axiolab Bio-TL/FL)
- Advanced features in Labscope/Matscope

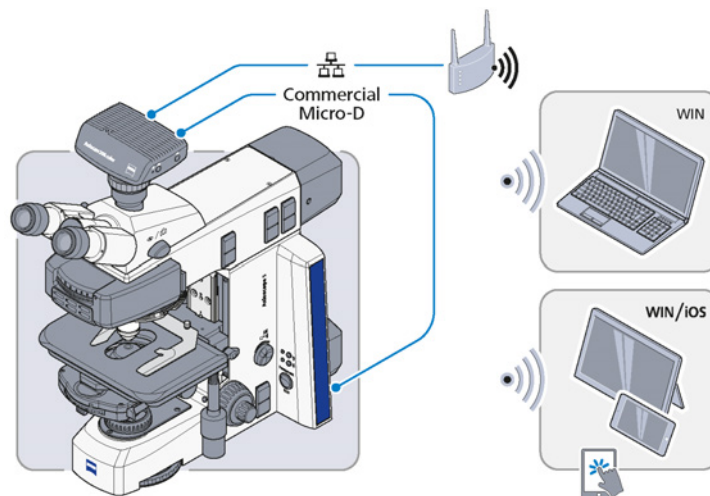

Fig. 81: Axiocam connected with Labscope/Matscope via a WLAN router

11.13.2.5 Axiocam Connected with Labscope/Matscope via a USB

Purpose The camera is used to capture the microscopic image.

Function The camera is powered by the microscope via the USB (Commercial Micro-D power) cable.

An optional monitor can be connected to the camera via an HDMI cable.

A workstation or Windows Surface can be connected to the camera via a USB cable.

Functions such as the Light Manager, encoding, ECO mode and image enhancement are automatically launched.

When a monitor is connected, live images can be viewed on the monitor display. Live images can also be viewed on a workstation or Surface and advanced features in Labscope/Matscope are available.

Functionality of the microscope:

- Light Manager
- Coded components
- ECO mode
- Image enhancement
- Observe live images
- Record and save images via software
- One-key fluorescence (this works only with Axiolab Bio-TL/FL)
- Advanced features in Labscope/Matscope

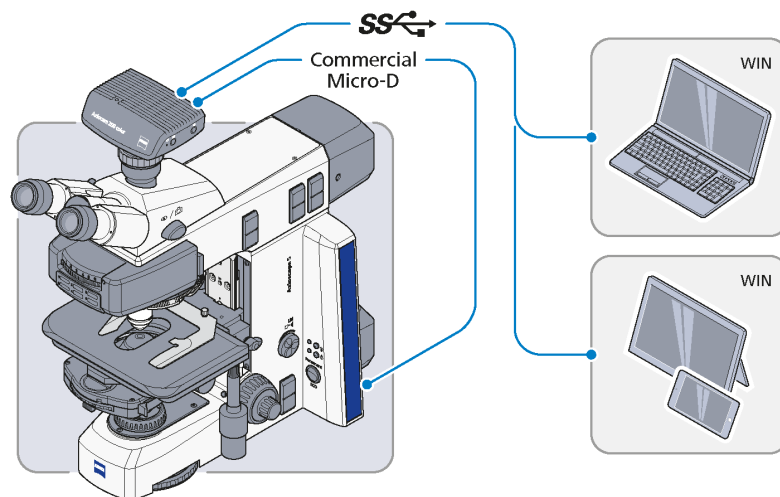

Fig. 82: Axiocam connected with Labscope/Matscope via a USB

11.13.2.6 Axiocam Connected with ZEN Software via a USB

Purpose The camera is used to capture the microscopic image.

Function The camera is powered by the microscope via the USB (Commercial Micro-D power) cable.

A workstation can be connected to the camera and the microscope stand via USB cables at the same time.

Functions such as the Light Manager, encoding and ECO mode are automatically launched.

Live images can also be viewed on the workstation and basic features in ZEN are available.

Functionality of the microscope:

- Light Manager
- Coded components
- ECO mode
- Image enhancement
- Observe live images
- Record and save images via software
- Basic features in ZEN

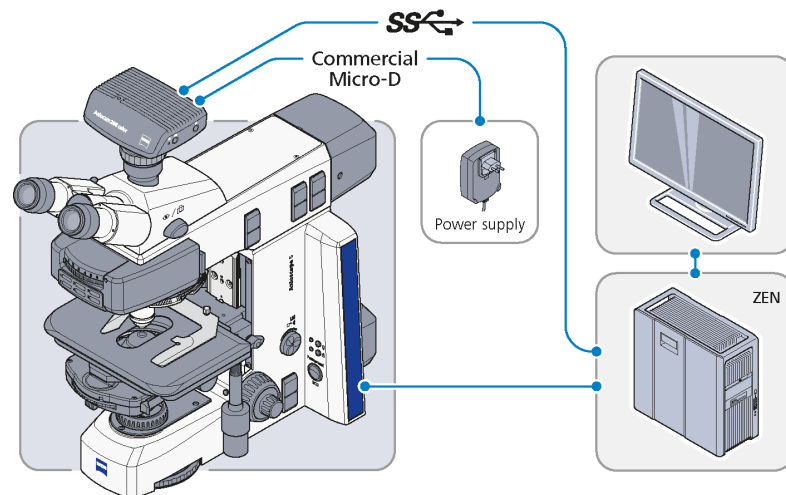

Fig. 83: Axiocam connected with ZEN software via a USB

11.14 Condenser, achromatic-aplanatic 0.9 BF DF PhC DIC

Purpose Condensers are used to optimize the transmitted light illumination. The condenser is usable for brightfield, darkfield, phase contrast and DIC applications.

Position The condenser is mounted on the condenser carrier of the stand.

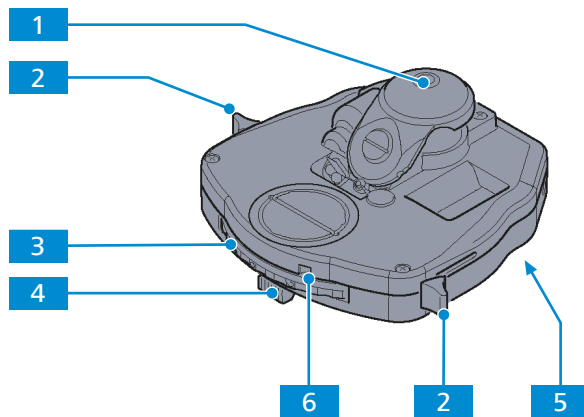

Fig. 84: Condenser, achromatic-aplanatic 0.9 BF DF PhC DIC

- | | |
|---|---|
| 1 Front lens | 2 Lever for switching the front lens in/out (left/right) |
| 3 Knurled ring for adjusting the position of the 5-positions turret disk | 4 Sliding control for setting the aperture diaphragm |
| 5 Dovetail ring mount | 6 Display field of the adjusted turret disk position |

11.14.1 Assembling the Condenser, Chromatic-aplanatic 0.9 BF DF PhC DIC

Info

If an additional component, e.g. a polarizer, has been mounted beneath the condenser carrier, the stage carrier should be removed before installing the condenser.

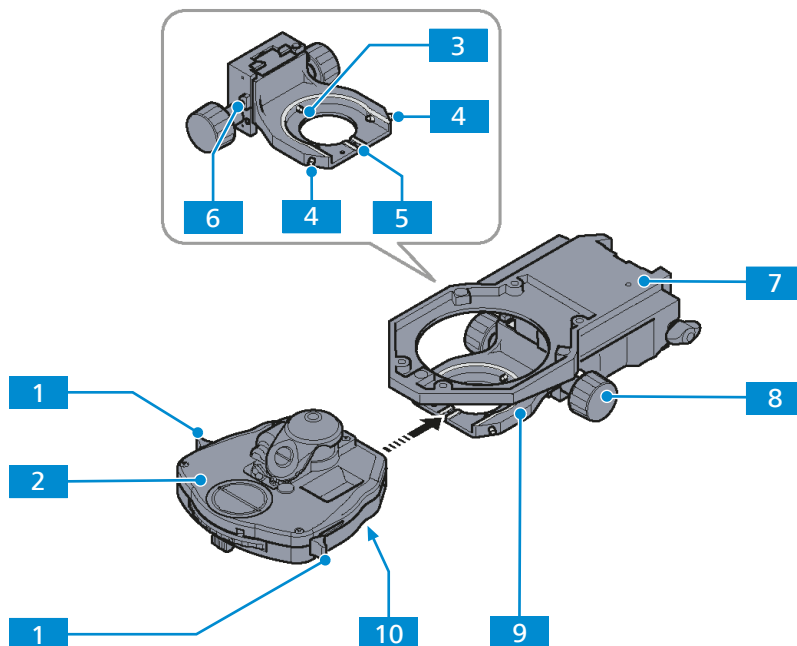
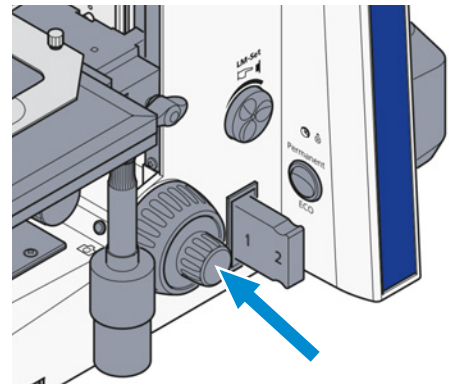

Fig. 85: Installing the condenser, achromatic-aplanatic 0.9 BF DF PhC DIC

- Procedure**
1. Carefully move the stage carrier **7** to the upper stop position. Use the focusing drive.
NOTICE Make sure that the stage does not collide with the objective.



2. Swivel out the front lens on the condenser **2** using the lever **1**.
3. Unscrew both centering screws **4** on the condenser carrier **9** until their ends are no longer visible.
4. Loosen the clamping screw **6** of the condenser carrier until the maximum vertical adjusting range is usable.
5. Using the knurled knob **8** for vertical adjustment, push the condenser carrier down as far as it will go.
NOTICE If using a low-power system, make sure that this does not come to rest on the luminous-field diaphragm.
6. Insert the condenser between the condenser carrier and the stage carrier **7**. In doing so, align the screwed stud bolt **10** on the underside of the condenser with the groove **5** of the condenser carrier.
7. Press the condenser with the dovetail ring against the mainspring **3** of the condenser carrier until the condenser sits horizontally on the condenser carrier.
8. Screw in the centering screws **4** until they engage with the dovetail ring of the condenser.
9. Screw in the clamping screw **6** without clamping the vertical drive.

Proceed in the reverse order for removal.

11.14.2 Centering the Darkfield Diaphragm of the Condenser

Parts and Tools  2x Hex key, 1.5 mm

- Prerequisite**
- ✓ A suitable condenser with modulator disk is installed.
 - ✓ The illumination is adjusted for transmitted light brightfield microscopy.

- Procedure**
1. Set the modulator disks to position D (or DF = darkfield).
 2. Remove one eyepiece from the binocular tube or replace it with the auxiliary microscope.
 3. Observe the exit pupil of the objective.

- Turn the two centering screws, until the exit pupil of the objective appears homogeneously dark.

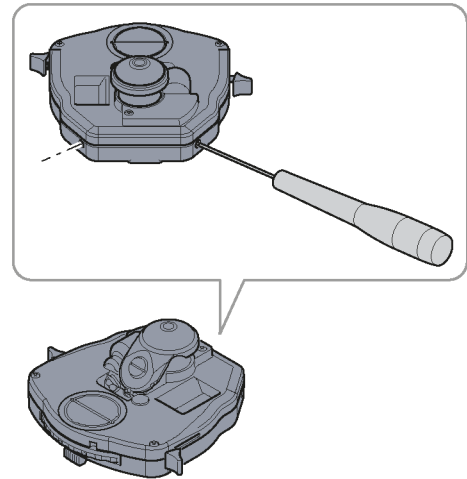

- Insert the eyepiece.

11.14.3 Centering the Annular Phase Diaphragm of the Condenser

Parts and Tools 🔧 2x Hex key, 1.5 mm

- Prerequisite**
- ✓ A suitable condenser with modulator disk is installed.
 - ✓ The illumination is adjusted for transmitted light brightfield microscopy.

- Procedure**
- Set the modulator disks to position **Ph** (phase contrast).
 - Remove one eyepiece from the binocular tube or replace it with the auxiliary microscope.
 - Observe the exit pupil of the objective.
 - Check the centering and the overlap of the lighter annular phase diaphragm (in the condenser) with the darker phase ring (in the objective). Both rings must be centered and overlapping **B**.
 - If the overlap is not exact **A**, recenter the lighter annular diaphragm.

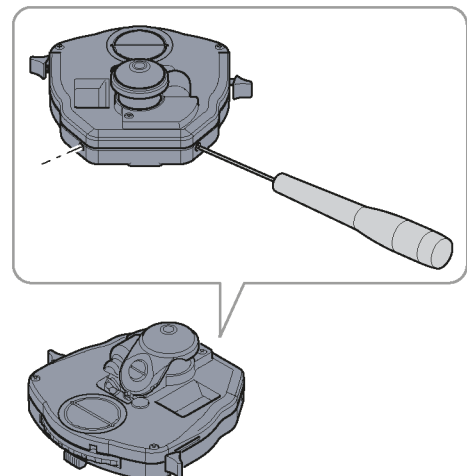
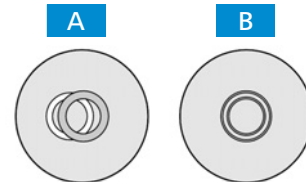

- Remove the auxiliary microscope and replace the eyepiece.

11.15 Assembling the Intermediate Plate for Analyzer Slider

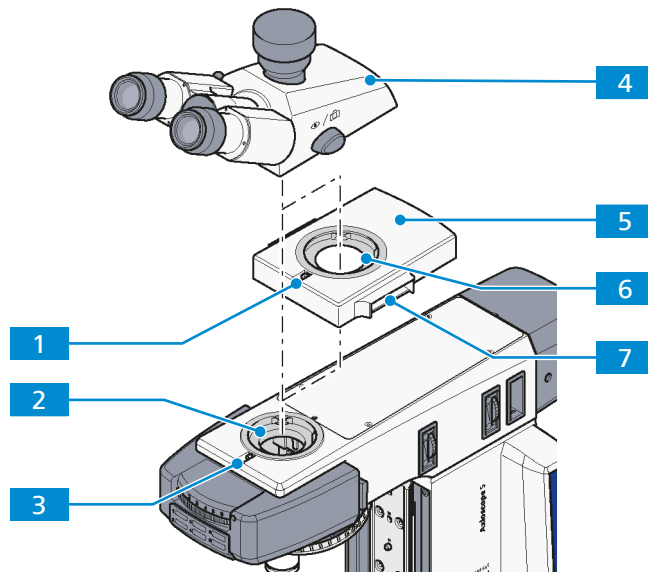

Parts and Tools  Hex key, 3.0 mm

- Procedure**
1. Loosen the clamping screw of the stand **3**.
 2. Replace the binocular tube **4**.
 3. Unscrew the tube lens of the tube (accessible from the bottom). Use the included ring tool.
 4. Screw the tube lens included with the intermediate plate into the binocular tube.
 5. Insert the intermediate plate **5** with the dovetail ring into the stand mount **2**.
 6. Tighten the clamping screw of the stand .
 7. Hold the binocular tube at an angle, insert it with the dovetail ring into the mount of the intermediate plate **6** and turn into a horizontal position.
 8. Rotate the binocular tube into the desired observation position.
 9. Tighten the clamping screw of the intermediate plate **1**.
 10. Insert the analyzer slider into the slider slot **7**, if applicable.

Proceed in the reverse order for removal.

11.16 Assembling the Tube Lens Turret

- Prerequisite**
- ✓ The microscope is switched off.
 - ✓ The tube is removed (see *Assembling the Intermediate Plate for Analyzer Slider* [[▶ 191](#)]).

- Procedure**
1. Unscrew the tube lens (accessible from the bottom). Use the included ring tool.
 2. Insert the tube lens turret's dovetail ring into the tube mount.
 3. Tighten the clamping screw.
 4. Mount the binocular tube.

Proceed in the reverse order for removal.

11.17 Assembling and Adjusting the Magnification Changer 4x

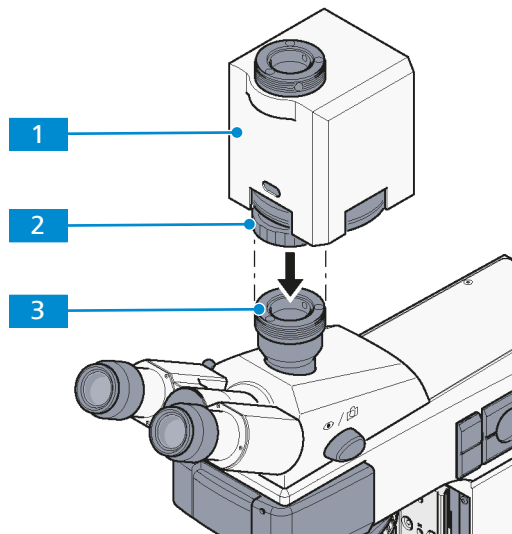

Prerequisite ✓ The microscope is switched off.

- Procedure**
1. Remove the *camera*, *camera adapter* [▶ 181] or the dust protection cover from the camera port **3** of the photo tube.
 2. Mount the magnification changer **1** on the camera port.
 3. Adjust the magnification changer.
 4. Tighten the retainer nut **2**.
 5. If required, adjust the locking power for the magnification modules stop position. Use the screw located on the bottom of the magnification changer housing. The screw is labeled with a white circle.
 6. Mount the camera on the camera port of the magnification changer. Use the appropriate adapter.

Proceed in the reverse order for removal.

11.18 Exchanging the Filters in the Filter Wheel for Transmitted Light

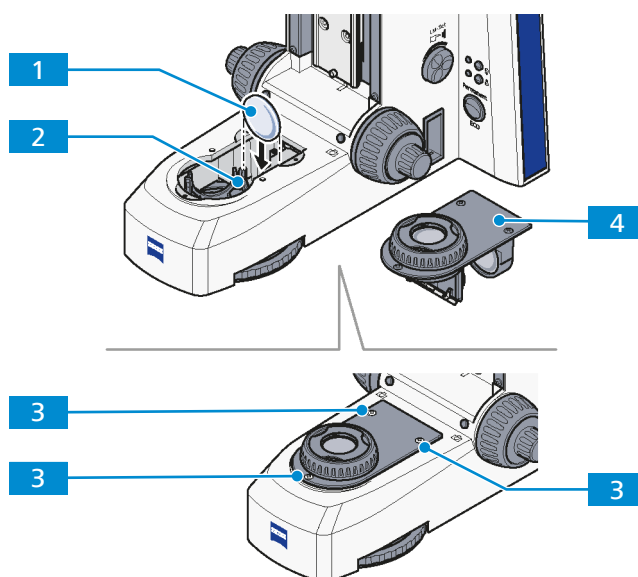

Prerequisite ✓ The stage carrier is *removed* [▶ 68].

- Procedure**
1. Unscrew three screws **3** of the luminous-field diaphragm socket **4**.
 2. Remove the socket from the stand base.
 3. Remove the filter **1** to be changed from the filter wheel.
 4. Put the new filter into the position **2**.
 5. Repeat the procedure for all filter wheel positions.
 6. Re-mount the field diaphragm socket.

11.19 Dual Observation

Purpose The accessory unit allows two people to look at the samples through eyepieces at the same time. Both users will be able to have the simultaneous view of the sample.

Position The dual observation unit is mounted on the top of the stand.

Function The main observer (with the microscope stand) has a black stick to control the position of the arrow in the vision.

The following features and controls are available:

- Four-color LED (blue, green, red and white) arrow in the field of view to point at the region of interests
- Field of view 23 mm

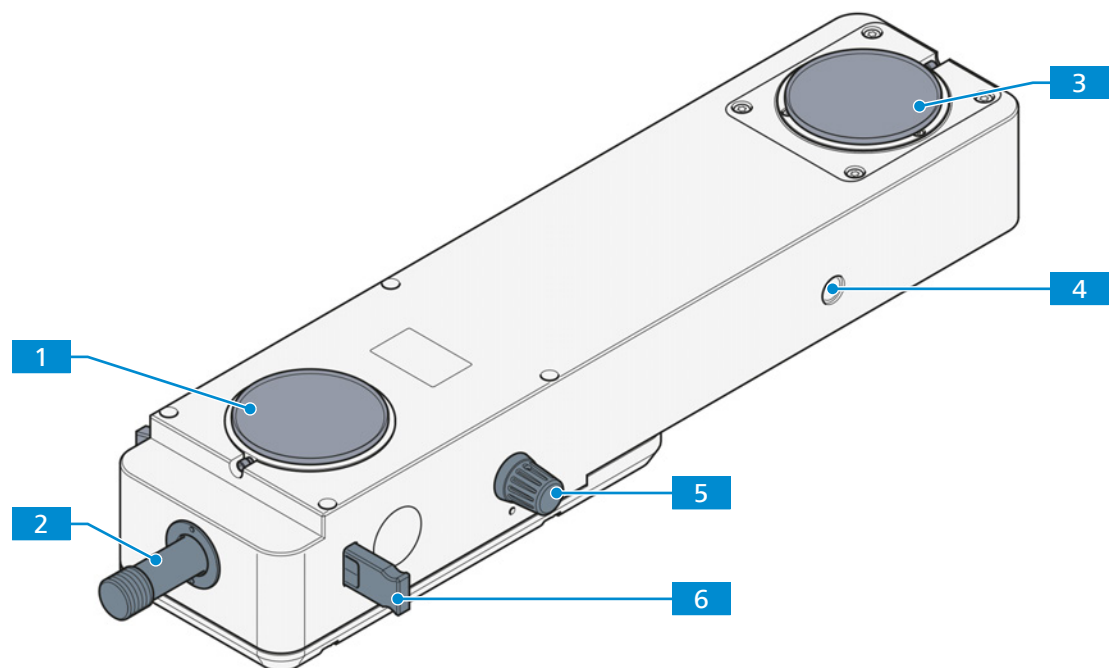

Fig. 86: Dual Observation

- | | |
|---|--|
| 1 Observation tube mount for main observer | 2 Joystick for LED arrow position control |
| 3 Observation tube mount for co-observer | 4 DC input socket (5V) |
| 5 ON/OFF switch | 6 Filter plate for LED arrow color changing |

11.19.1 Preparing the Binocular Tubes

1. Remove the tubes lenses from all binocular tubes [▶ 194], except for 425520-9080-000.
2. Install the adaptation set to the binocular tube for the main observer [▶ 195].
3. Install the neutral density filter to the binocular tube for the co-observer [▶ 195].

11.19.1.1 Removing the Tube Lens from the Binocular Tubes

NOTICE

Malfunction due to tube lens confusion

Binocular tubes and tube lenses are properly matched to one another.

- ▶ Mark binocular tubes and tube lenses in such a way that they can be assigned to each other again for later use.

Parts and Tools 🔧 Ring tool

Prerequisite ✓ The binocular tube is removed from the microscope.

Procedure 1. Put the binocular tube **3** upside down on the table.

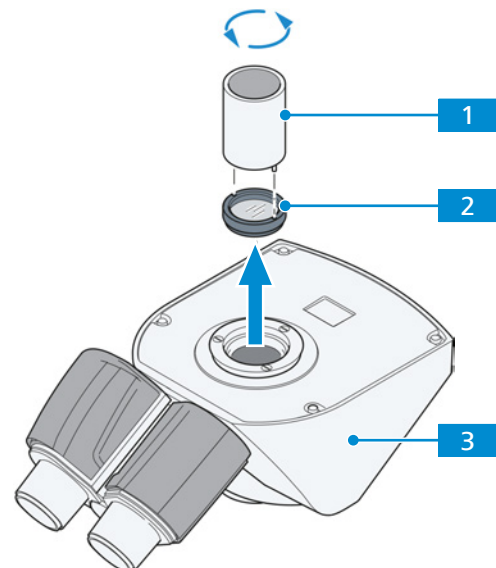

2. Remove the tube lens **2** using the ring tool **1**.
3. Store the tube lens in dust-free conditions.
4. Turn the binocular tube.

11.19.1.2 Inserting the Adaptation Set into the Binocular Tube for the Main Observer

The neutral glass filter should be used with Axioscope tubes only. The adaptation set is delivered fully assembled with a glass plate. The included neutral density filter is not required for the dual observation component.

The neutral density filter is only required, when super low light intensity is to be achieved.

Parts and Tools 🔧 Mounting tool

Prerequisite ✓ The tube lens is *removed* [▶ 194].
Exception: When using the ergo-tube 425520-9080-000, the tube lens should not be removed.

- Procedure**
1. Put the binocular tube **3** upside down on the table.
 2. Insert the adaptation set **2** using the mounting tool **1**.

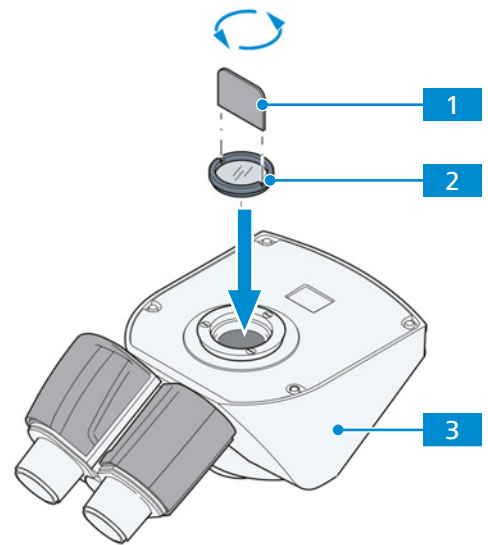

3. Turn the binocular tube.

11.19.1.3 Inserting the Neutral Density Filter into the Binocular Tube for the Co-observer

The neutral density filter with 50% transmission is recommended for the co-observer if a photo tube is used on the main observer and a tube without a photo port is used on the co-observer.

Parts and Tools 🔧 neutral density filter with 50% transmission

Prerequisite ✓ The tube lens is *removed* [▶ 194].
Exception: When using the ergo-tube 425520-9080-000, the tube lens should not be removed.

- Procedure**
1. Put the binocular tube upside down on the table.
 2. Insert the neutral density filter into the dovetail mount of the binocular tube.
 3. Install the binocular tube to the dual observation.

11.19.2 Assembling the Dual Observation

Info

All tubes should be equipped with eyepieces of the same field diameter (preferably 23 mm) in order to obtain same-size fields of view for the main observer and the co-observer.

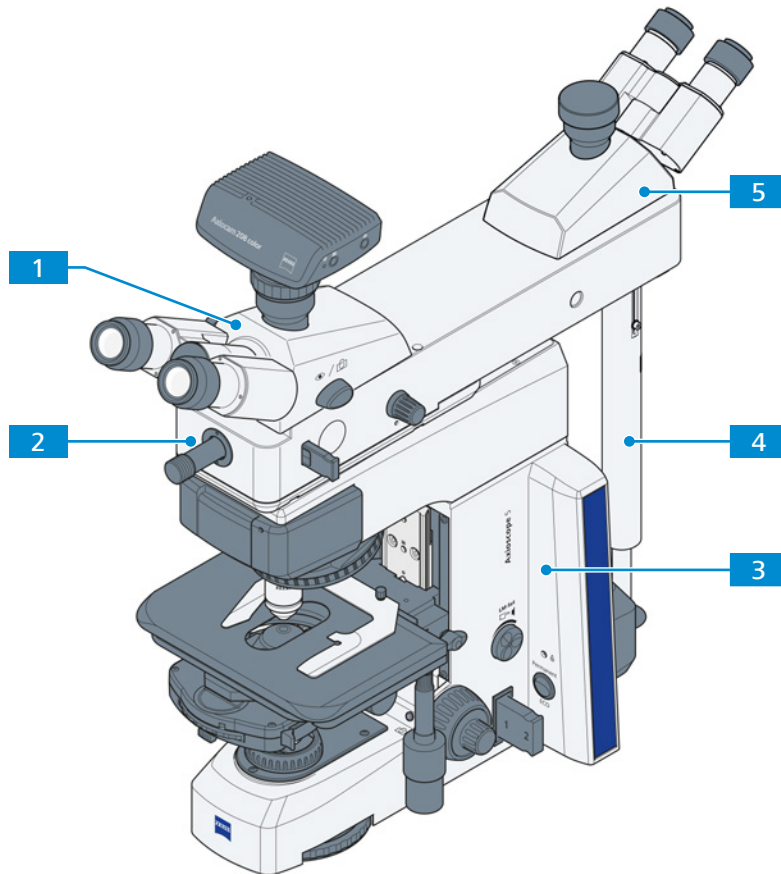

Fig. 87: Axioscope 5 TL with dual observation

- | | | | |
|----------|--------------------------------------|----------|------------------|
| 1 | Binocular tube for the main observer | 2 | Dual observation |
| 3 | Microscope stand | 4 | Column |
| 5 | Binocular tube for the co-observer | | |

- Prerequisite**
- ✓ The tube lenses are *removed from both binocular tubes* [▶ 194].
 - ✓ The adaptation set is *installed to the binocular tube for main observer* [▶ 195].
 - ✓ The neutral density filter is *installed to the binocular tube for the co-observer* [▶ 195].
 - ✓ The microscope is placed on a suitable table.

- Procedure**
1. Install the dual observation **2** on the microscope stand **3** with the joystick facing to the main observer.
 2. Install the column **4**.
 3. Install the *binocular tube* [▶ 65] for the main observer **1**.
 4. Install the *eyepieces* [▶ 66] for the main observer.
 5. Install the binocular tube for the co-observer **5**.
 6. Install the eyepieces for the co-observer.
 7. Connect the plug-in power cord to the microscope stand.

11.19.3 Operating the Dual Observation

- Prerequisite**
- ✓ The dual observation is assembled.
 - ✓ The microscope is switched on.

- Procedure**
1. Switch on the dual observation by turning the rotary button clockwise.

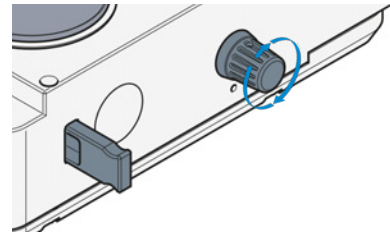

→ The blue LED below the knob lights up.

2. Adjust the light intensity by turning the rotary button.
3. Position the LED arrow in the field of view by means of the joystick.

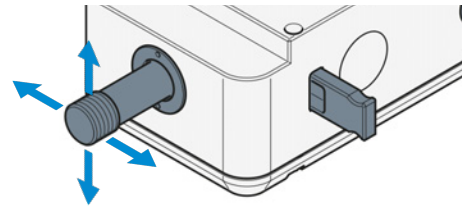

4. Set the color of the LED arrow by pulling or pushing the filter plate.

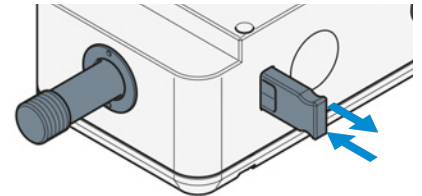

5. Re-focus the eyepieces of the co-observer by approx. 1/3 diopter to compensate the glass path of the removed tube lens.
6. Switch off the dual observation by turning the rotary button counterclockwise.

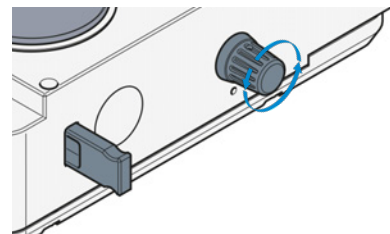

→ The blue LED below the knob goes out.

Revision History

Revision	Date of Issue	Introduced Modifications
2	08/2025	<ul style="list-style-type: none"> ▪ Chapter <i>Contact and Addresses</i> [▶ 8] added ▪ Corrections ▪ Viluma 5/7 light sources added ▪ Axiocam 202 mono and Axiocam 208 color replaced by Axiocam 203 mono and Axiocam 212 color ▪ Correction of chapter(s): <ul style="list-style-type: none"> – <i>Optical Risk Grouping</i> [▶ 15] – <i>EMC Information</i> [▶ 16] – <i>Product and Functional Description</i> [▶ 22] – <i>Functions of Stand Keys and Display Elements</i> [▶ 41] – <i>Transport and Storage</i> [▶ 116] – <i>Accessories and System Expansions</i> [▶ 123]
1	09/2024	<ul style="list-style-type: none"> ▪ Change of address of the manufacturer ▪ Correction of chapter(s): <ul style="list-style-type: none"> – <i>Dual Observation</i> [▶ 193] ▪ New material number as successor of 430035-7344-001, revision 18

Tab. 4: Revision History

Glossary

ACR (Automatic component recognition)

A function that recognizes automatically objectives, identifies reflector modules and recognizes the exchange of components.

BF (Brightfield)

Illumination and imaging system where direct light passes through the objective aperture and provides a bright background against which the image is viewed.

C-DIC

Differential Interference Contrast in circularly polarized light, a contrast method which employs the differential interference contrast technique with circularly polarized light, thus fully imaging sample structures which otherwise are only visible in a certain orientation

DF (Darkfield)

Illumination and imaging system that prevents direct light from entering the objective aperture.

DIC (Differential Interference Contrast)

An imaging light microscopy method that converts differences in the optical path length in the object into differences in the brightness of the image

FL (Fluorescence)

Phenomenon of a selective absorption of radiation with relatively short wavelength (i.e., relatively high energy) by matter with the result of the emission of radiation with longer wavelengths (i.e., lower energy), which persists only very briefly after the excitation has ceased.

P&C (Push and Click)

Functionality of a product that can be mounted without the use of tools by simply inserting it and then audibly snapping into place.

PCBA

Printed Circuit Board Assembly

PE conductor

A protective conductor provided for protective earthing.

PlasDIC

Differential Interference Contrast for Plastic Receptacles

PPE (Personal protective equipment)

Equipment used to protect persons from harm in the working environment.

PSU (Power supply unit)

Chiefly used for combinations of transformers and rectifiers that convert AC mains power to a lower-voltage DC power used in electronic devices. Superordinate concept -- see cross reference for specific types.

RL (Reflected Light)

Designation for microscopy techniques to image light that was reflected by the object

Sample or Specimen

A representative part or a single item from a larger whole or group especially when presented for inspection or shown as evidence of quality.

TIC (Total Interference Contrast)

Total Interference Contrast in circularly polarized light is a technique for imaging and layer thickness measurement in materials microscopy. Contrary to traditional polarization interferometers, work in this technique is carried out in circularly polarized light.

TL (Transmitted Light)

Light used for illuminating a object, where the light is transmitted through the object.

ZEISS service representative

Specially trained service expert, either ZEISS staff or authorized service partner of ZEISS.

ZEN software

Modular software, that is controlling all ZEISS light microscope systems and has a wide application field: acquiring images, processing images and analyzing images.

Index

A

Accessories	123
Adaptation set	195
Adjustment tool of HBO 100	
assembling	141
Air Conditioning and Quality	118
Analyzer slider	151
Aperture diaphragm	50, 51, 52, 188
Auxiliary microscope	66
Axiocam	180, 182
Axioscope 5 TL	23
Axioscope 5 TL/FL	25
Axioscope 5 TL/RL	27
Axioscope 5 TL/RL Pol	28
Axioscope 5 Vario	31
Axioscope 7 RL	37
Axioscope 7 TL	33
Axioscope 7 TL/FL	35
Axioscope 7 TL/RL MAT	39

B

Beam splitter of a reflector module	
changing	161
Binocular photo tube	
44, 45, 46, 126, 127, 128	
Binocular tube	125
remove tube lens	194
Bireflectance	63, 101
Birefringence	57, 88
Brightfield	56, 60, 79, 93

C

Camera	180
installing	181
Filter carrier	
installing	174
C-DIC	60, 99
Circular polarization contrast	59, 90
Circular polarizer	172
Clamping device	155
installing	155
Cleaning	
Water-soluble contaminations	108
Colibri 3 LED light source	
assembling	147
Color filter carrier	171, 172, 173
Condenser	50, 51, 188
changing diaphragms	165
mounting	189
Condenser carrier	50
adjusting height stop	76
installing	70
Conoscopic observation	59
Connecting to the mains	72
Conoscopic	91
Contamination	117

D

Darkfield	56, 60, 82, 84, 96
Darkfield condenser	
assembling	71
Decontamination	117
Annular phase diaphragm	
centering	190
Darkfield diaphragm	
centering	189
DIC	56, 60, 86, 98
DIC slider	152
Disposal	117
Dual observation	
installing	196
operating	197
Dual observation	193

E

ECO mode	78
Reversible eyecups	
installing	150
Eyepiece	48, 66
Eyepiece Pol	178
Eyepiece reticle	48
Eyepieces	48
Eyepiece reticle	
focusing	74

F

Filter	171, 172, 173
Filter in the filter wheel	
replacing	193
Filter of a reflector module	
changing	161
Fluorescence	63, 102
Focus drive	
adjusting height stop	76
Focusing	74
Friction of coaxial knurled knobs of the stage	
158	
Fuse	
exchange	110, 138

G

General Safety Information	14
----------------------------	----

H			
HAL 100			
assembling	134		
power supply	132		
HAL 100 light source			
adjusting	134		
Hazards	17		
Biological	18		
Crushing	17		
Electromagnetic interference	19		
Ergonomic	18		
Infection	18, 19		
Operating Environment	18		
Optical radiation	19		
Prevention	17		
Skin irritation	18		
Thermal	19		
Transport	17		
HBO 100	139		
adjusting	143		
assembling	142		
I			
Improper use	13		
Intermediate plate for analyzer slider			
installing	191		
Interpupillary distance	74		
L			
Lambda 4/plate	172		
Lambda plate	171		
LED modules for Colibri 3			
changing	147		
usability	122		
LED10 light source for reflected light			
assembling	145		
LED10 light source for transmitted light illumination			
assembling	145		
Light Manager			
disabling	78		
enabling	76		
function	55		
saving ratios	77		
Location requirements	118		
Low-power system	176		
centering	177		
installing	177		
M			
Magnification changer			
assembling	192		
Mains			
connecting to	72		
Mains connection	118		
Maintenance	106		
interval	107		
schedule	107		
work	108		
Mechanical stage	52, 53, 153		
additional sleeves removing	157		
adjusting the friction	158		
installing	69, 154		
recovering the travel range	110		
setting the drive length	157		
Mechanical stage, motorized			
installing	70		
Mechanical stage, rotatable			
centering	154		
Modulator disk			
installing	163		
N			
Nosepiece	49, 67		
O			
Object guide			
installing	178		
Objective	49, 67		
centering	179		
Operation			
Prerequisites	73		
Optional system expansions	123		
Installation	123		
P			
Path differences	59, 89		
Permanent mode	78		
Phase contrast	56, 85		
Photo tube	44, 45, 46, 126, 127, 128		
Pinhole diaphragm	66		
PlasDIC	57, 87		
PlasDIC slit diaphragm			
installing	164		
Pleochroism	101		
Polarization	57, 59, 88, 101		
Polarization direction	57, 89		
Polarization contrast			
circular	90		
Polarizer	169, 170, 171, 172, 173, 175		
installing	174, 175		
Power supply			
HAL 100	132		
HBO 100	140		
HBO 100	140		
Prerequisites			
Operation	73		

R

Reflected light	
brightfield	60, 93
C-DIC	60, 99
darkfield	60, 96
DIC	60, 98
fluorescence	63, 102
polarization	63, 101
TIC	60, 100
Reflector module	
assembling	159
Reflector slider	55
Reflector turret	55
assembling	68
Requirements	
for Operators	14
Reticle	48
Rotary stage	54, 155
centering	156
installing	155

S

Safe Operating Condition	14
Safety	13, 106
devices	21
interlocks	21
Sample space extension	
installing	165
Factory settings	115
Shutdown	116
Spare parts	15
Specimen guide	54
Specimen holder	53
installing	69
Stage carrier	
assembling	68
Stand column	
installing	65
Stop slider	152
Switching off	105
Switching on	73

T

TIC	60, 100
Training	14
Transmitted Light Polarization	59
conoscopic	91
Transmitted light	
brightfield	56, 79
darkfield	56, 82, 84
DIC	56, 86
phase contrast	56, 85
PlasDIC	57, 87
polarization	57, 88
Troubleshooting	111
Tube	44, 45, 46, 125, 126, 127, 128
assembling	66
assembling components	66

U

Unpacking	64
Upper part of the stand	
adjusting	75
assembling	65

V

Viewing height	74
----------------	----

W

Warning	
labels	20
lights	20
Weight and Sizes	118

Z

ZEISS	
Service agreements	106

