



UNIVERSAL ROBOTS

Installation Guide

OEM Control Box



The information contained herein is the property of Universal Robots A/S and shall not be reproduced in whole or in part without prior written approval of Universal Robots A/S. The information herein is subject to change without notice and should not be construed as a commitment by Universal Robots A/S. This document is periodically reviewed and revised.

Universal Robots A/S assumes no responsibility for any errors or omissions in this document.

Copyright © 2019-2025 by Universal Robots A/S.

The Universal Robots logo is a registered trademark of Universal Robots A/S.



Contents

1. About this Document	10
1.1. About this Document	10
1.2. Contact Information	10
2. What's in the Box	11
3. Safety	12
3.1. Safety Message Types	13
3.2. General Safety Precautions	14
3.3. OEM AC FlexTail Safety Precautions	15
4. Electrical Installation: AC	16
4.1. Required Items	16
4.1.1. How to Connect Wires to the Connector	17
4.2. Power Source Wiring: AC	17
4.2.1. Robot Connection	19
4.2.2. Circuit Breaker Installation	20
5. Electrical Installation: OEM AC FlexTail	21
5.1. How to Connect Wires to the Connector	22
5.2. Robot Connection for OEM AC FlexTail	22
5.2.1. Circuit Breaker Installation	24
6. Electrical Installation: DC	25
6.1. Required Items	25
6.1.1. How to Connect Wires to the Connector	26
6.2. Power Source Wiring: DC	26
6.2.1. Robot Connection	28
6.2.2. Circuit Breaker Installation	29
7. Mechanical Installation	30
7.1. Working Environment Guidelines	30
7.2. Mounting the OEM Control Box	30
7.2.1. Grounding	31
8. Connecting External Devices	32
8.1. External Device Connection Ports	32
8.1.1. How to Connect a Teach Pendant	33
8.1.2. How to Use Remote Control and Local Control	34
8.2. Connecting Devices	35
8.2.1. To Connect a 3-Position Enabling Device	35
8.2.2. To Connect an Operational Mode Switch	36



8.3. Remote ON/OFF Control and Emergency Stop	36
8.3.1. Connecting the ON/OFF Control	36
8.3.2. Connecting the Remote Emergency Stop	37
9. OEM Control Box Specifications	38
9.1. Technical Specifications	38
9.2. Electrical Specifications	38
9.3. Control Unit Heat Dissipation	39
9.4. Dimensional Drawings [mm]	40
9.5. Dimensional Drawings [mm] OEM AC FlexTail	41
10. Troubleshooting	42
10.1. OEM Control Box AC variant	42
10.2. OEM Control Box DC variant	42
11. Robot Arm Cleaning and Inspection	43
12. Cable Strain Relief Bracket	48
12.1. OEM Control Box AC	48
12.2. OEM Control Box DC	50
13. Certifications	51

1. About this Document

1.1. About this Document

Description This guide describes Universal Robots OEM Control Box installation and how to connect the OEM Control Box to both AC and DC power sources.

This guide also describes installation for the latest version of the OEM Control Box, the OEM AC FlexTail.



NOTICE

Universal Robots disclaims any liability, even if all guidelines in this document are followed.

1.2. Contact Information

Company Details Universal Robots A/S
Energivej 51, 5260 Odense S, Denmark
+45 89 93 89 89
<https://www.universal-robots.com>

2. What's in the Box

Description

The box contains the following items:

- The OEM Control Box
 - This document
 - WAGO 831 four-pole female connector
 - Cable strain relief bracket
-

3. Safety

3.1. Safety Message Types

Description

Safety messages are used to emphasize important information. Read all the messages to help ensure safety and to prevent injury to personnel and product damage.



WARNING

Indicates a hazardous situation that, if not avoided, can result in death or serious injury.



WARNING: ELECTRICITY

Indicates a hazardous electrical situation that, if not avoided, can result in death or serious injury.



WARNING: HOT SURFACE

Indicates a hazardous hot surface where injury can result from contact and non-contact proximity.



CAUTION

Indicates a hazardous situation that, if not avoided, can result in injury.



GROUND

Indicates grounding.



PROTECTIVE GROUND

Indicates protective grounding.



NOTICE

Indicates the risk of damage to equipment and/or information to be noted.



READ MANUAL

Indicates more detailed information that should be consulted in the manual.

3.2. General Safety Precautions

Description Read the safety messages below before installing your OEM Control Box. Find more safety information in the Safety chapter of the Universal Robots User Manual.



WARNING

Failure to verify and validate safeguarding and functionality can result in death or serious injury.

- Ensure all risk reduction works as intended and achieves the needed risk reduction.



WARNING

Failure to perform a risk assessment before installation and operation can result in personnel injury or equipment damage.

- Perform a risk assessment before installation and operation.
- Read the UR User Manual and UR Service Manual.



WARNING: ELECTRICITY

Installing or maintaining equipment connected to a power source can lead to electric shock.

- Disconnect the equipment from the power source before installation or maintenance.



CAUTION

Failure to perform installation or maintenance correctly can result in equipment damage or personnel injury.

- Only qualified personnel shall perform installation, start-up, and maintenance.
- Read the UR User Manual and the UR Service Manual.



GROUND

Incorrect connection of the power source or ground wires can result in equipment damage or personnel injury.

Damage caused by invalid power source connection is not covered by warranty.

Before starting the operation:

- Ensure that the power source wiring is correct.
- Ensure that the grounding is correct.



NOTICE

Electrostatic Discharge (ESD) can damage sensitive components in the OEM Control Box.

- Always wear an ESD wrist strap when working with the OEM Control Box electrical interfaces.

3.3. OEM AC FlexTail Safety Precautions

Description

The notes below recommend how to handle your OEM AC FlexTail.



NOTICE

Harsh pulling or jerking the OEM AC FlexTail cable can result in damage to equipment.

- Avoid harsh pulls or jerking motions on the OEM AC FlexTail cable.



NOTICE

The OEM AC FlexTail is designed for fixed installation. As such, the OEM AC FlexTail cable shall be fixed relative to the position of the OEM AC FlexTail box.

- Do not overextend the OEM AC FlexTail cable.

4. Electrical Installation: AC

Description This section describes how to connect the OEM Control Box to an AC power source.



WARNING: ELECTRICITY

Installing or maintaining equipment connected to a power source can lead to electric shock.

- Disconnect the equipment from the power source before installation or maintenance.

- For information on electrical specifications, see OEM Control Box Specifications

4.1. Required Items

You need the following items to connect the wires:

- The WAGO 831 four-pole female connector (included with the OEM Control Box).
- A flat-bladed screwdriver, blade 5.5 x 0.8 mm. For example: WAGO 210-721.
- Three wires with ferrules.

Required items

The illustration below shows the required items.

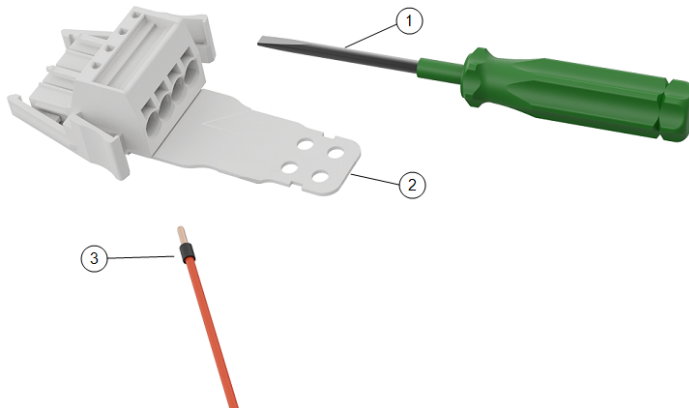

1	Flat bladed tool	2	WAGO female connector (AC depicted)
3	Wire with ferrule		

4.1.1. How to Connect Wires to the Connector

Description This section describes how to connect wires to a connector with locking levers:

- To connect the wires**
1. Insert the screwdriver into a flat slot next to a connector hole.
 2. Push the screwdriver until the clamp inside the hole opens. Keep the screwdriver in the slot, as shown.

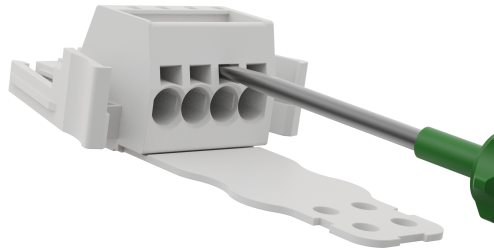

3. Insert the wire ferrule into the open hole.
4. Ensure that the wire ferrule is firmly placed, remove the screwdriver to close the hole.

4.2. Power Source Wiring: AC

Use the following scheme to attach wires to the connector.

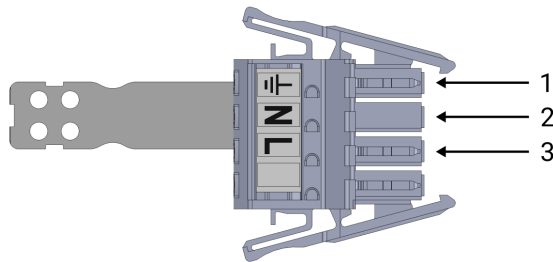

1	Ground (Earth)	2	Neutral
3	Live (Phase)		

To connect the OEM Control Box to the power source:

1. Connect the following wires to the connector: Neutral, Live and Ground.
2. Connect the neutral, and live wires to main power supply. Connect the ground wire to the facility ground.
3. Plug the connector into the power source socket on the OEM Control Box.

**NOTICE**

Connecting wires to poles without labels can interfere with the operation of the robot.

- Do not connect wires to poles without labels.

4.2.1. Robot Connection

Description The robot arm connector, illustrated below, is next to the power supply connector. For details on connecting the robot arm cable, refer to the Universal Robots User Manual.

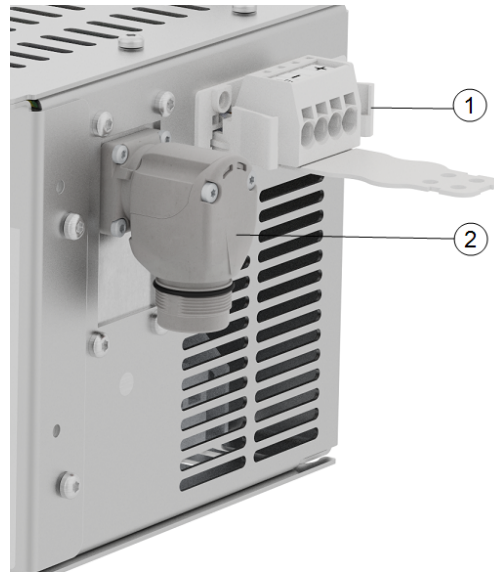

1	Power connector	2	Robot arm connector
---	-----------------	---	---------------------

4.2.2. Circuit Breaker Installation

Description

Use a double pole circuit breaker to protect the power input connector, as it can also be used as a switch. If a fuse is used, then a two-pole switch must be installed between the fuse and power input connector.

The following illustration shows the circuit breaker wiring scheme.

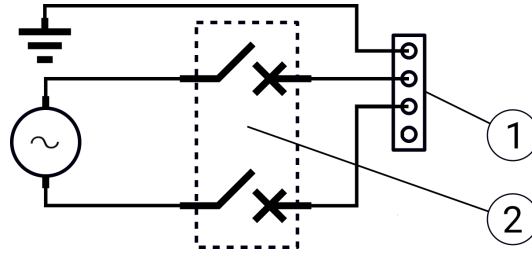

1	OEM power input	2	Circuit breaker
---	-----------------	---	-----------------



CAUTION

Failure to install appropriate fuses or circuit breakers can result in equipment damage or personnel injury.

- The installation shall comply with the standard IEC 60364.

5. Electrical Installation: OEM AC FlexTail

Description The main difference between the OEM Control Box and the OEM AC FlexTail is the cable extension between the Control Box and the robot arm connector, described in the following subsections.

The OEM AC FlexTail uses the same AC electrical installation described in the previous section. However additional items are required to attach the OEM AC FlexTail cable.



WARNING: ELECTRICITY

Installing or maintaining equipment connected to a power source can lead to electric shock.

- Disconnect the equipment from the power source before installation or maintenance.

Required items

You need the following items to connect the wires:

- The WAGO 831 four-pole female connector (included)
- A flat-bladed screwdriver, blade 5.5 x 0.8 mm. For example: WAGO 210-721
- Three wires with ferrule
- Four M4 screws (not included)

The illustration below shows the required items.

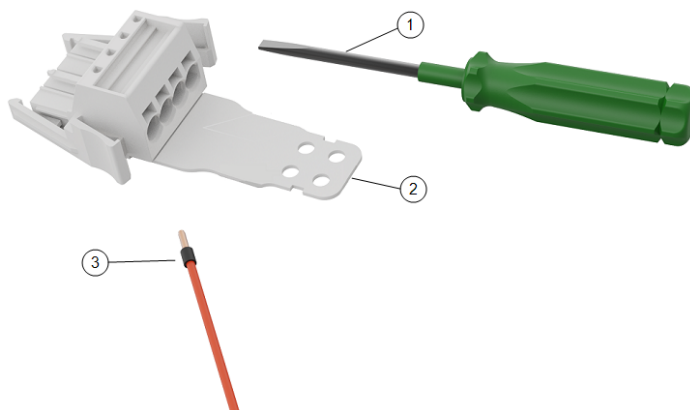

1	Flat bladed tool	2	WAGO female connector (AC depicted)
3	Wire with ferrule		

5.1. How to Connect Wires to the Connector

Description This section describes how to connect wires to a connector with locking levers:

To connect the wires

1. Insert the screwdriver into a flat slot next to a connector hole.
2. Push the screwdriver until the clamp inside the hole opens. Keep the screwdriver in the slot, as shown.

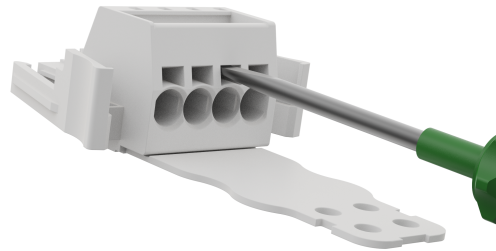

3. Insert the wire ferrule into the open hole.
4. Ensure that the wire ferrule is firmly placed, remove the screwdriver to close the hole.

5.2. Robot Connection for OEM AC FlexTail

Description The robot arm connector, illustrated below, is next to the power supply connector.

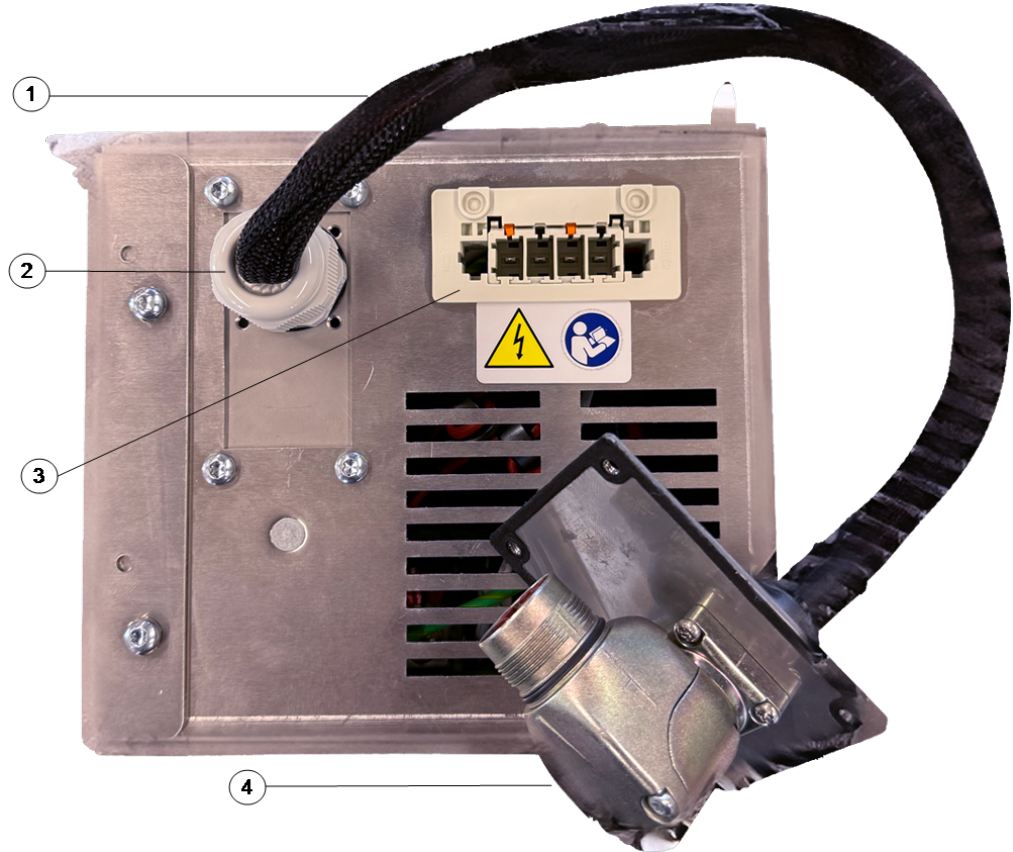

1	OEM AC FlexTail cable	2	Cable gland
3	OEM CB Connector	4	Robot arm connector

5.2.1. Circuit Breaker Installation

Description

Use a double pole circuit breaker to protect the power input connector, as it can also be used as a switch. If a fuse is used, then a two-pole switch must be installed between the fuse and power input connector.

The following illustration shows the circuit breaker wiring scheme.

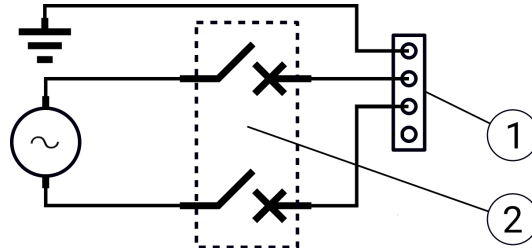

1	OEM power input	2	Circuit breaker
---	-----------------	---	-----------------



CAUTION

Failure to install appropriate fuses or circuit breakers can result in equipment damage or personnel injury.

- The installation shall comply with the standard IEC 60364.

6. Electrical Installation: DC

Description This section describes how to connect the OEM Control Box to an DC power source.



WARNING: ELECTRICITY

Installing or maintaining equipment connected to a power source can lead to electric shock.

- Disconnect the equipment from the power source before installation or maintenance.

- For information on electrical specifications, see Technical Specifications.

6.1. Required Items

Components You need the following items to connect the wires:

- The WAGO 831 four-pole female connector (included with the OEM Control Box).
- A flat-bladed screwdriver, blade 5.5 x 0.8 mm. For example: WAGO 210-721.
- Three wires with ferrules.

The illustration below shows the required items.

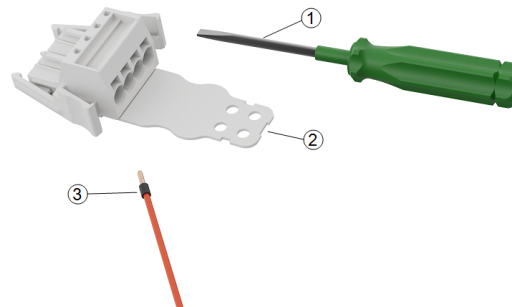

1	Flat bladed tool	2	WAGO female connector (DC depicted)
3	Wire with ferrule		

6.1.1. How to Connect Wires to the Connector

Connect Wires

1. Insert the screwdriver into a flat slot next to a connector hole.
2. Push the screwdriver until the clamp inside the hole opens. Keep the screwdriver in the slot, as shown.

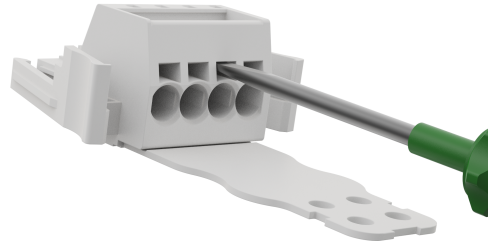

3. Insert the wire ferrule into the open hole.
4. Ensure that the wire ferrule is firmly placed, remove the screwdriver to close the hole.

6.2. Power Source Wiring: DC

Description

Use the following scheme to attach wires to the connector.

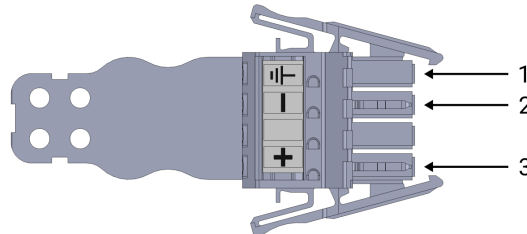

1	Ground	2	Negative
3	Positive		



NOTICE

Reversing the DC source polarity causes permanent damage to the OEM Control Box.

Property damage caused by invalid power source connection is not covered by warranty.

- Ensure that the polarity is correct before connecting the power source.

**Connect
Power
Source**

To connect the OEM Control Box to the power source:

1. Connect the following wires to the connector: Neutral, Line and Ground (if supported).
2. Connect the ground wire to the facility ground if the application supports such connection. Connect the negative, and positive wires to the DC source. Ensure that the polarity is correct.
3. Plug the connector into the power source socket on the OEM Control Box.

**NOTICE**

Connecting wires to poles without labels can interfere with the operation of the robot.

- Do not connect wires to poles without labels.

Soft Start Circuit

Description

When the OEM Control Box is connected to a DC source, the inrush current can reach up to 400 A for 200 μ s. This can cause damage to the DC source or shut down other electronics connected to it.

- Install a soft start circuit when using a DC source.

6.2.1. Robot Connection

Description

The robot arm connector, illustrated below, is next to the power supply connector. For details on connecting the robot arm cable, refer to the Universal Robots User Manual.

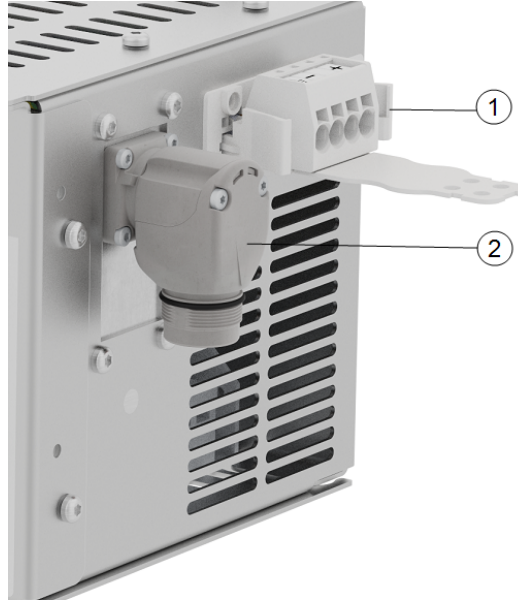

1	Power connector	2	Robot arm connector
---	-----------------	---	---------------------

6.2.2. Circuit Breaker Installation

Description Use a double pole circuit breaker to protect the power input connector, as it can also be used as a switch. If a fuse is used, then a two-pole switch must be installed between the fuse and power input connector.

The following illustration shows the circuit breaker wiring scheme.

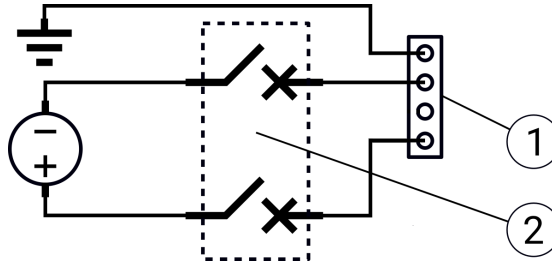

1	OEM power input	2	Circuit breaker
---	-----------------	---	-----------------



CAUTION

Failure to install appropriate fuses or circuit breakers can result in equipment damage or personnel injury.

- The installation shall comply with the standard IEC 60364.

7. Mechanical Installation

7.1. Working Environment Guidelines

Description

Follow these guidelines to ensure reliable operation of the OEM Control Box:

- Keep free from dust and dirt.
- Keep away from water, solvents, and chemicals.
- Keep ambient air temperatures flowing into the OEM Control Box within 0-50°C.
- Keep the aluminum controller frame temperature within 0-65°C.

7.2. Mounting the OEM Control Box

Mounting

Use the mounting holes, shown below, to mount the OEM Control Box. Depending on version, your OEM Control Box can appear slightly different to the illustrations. Functionality is not affected by any external differences.

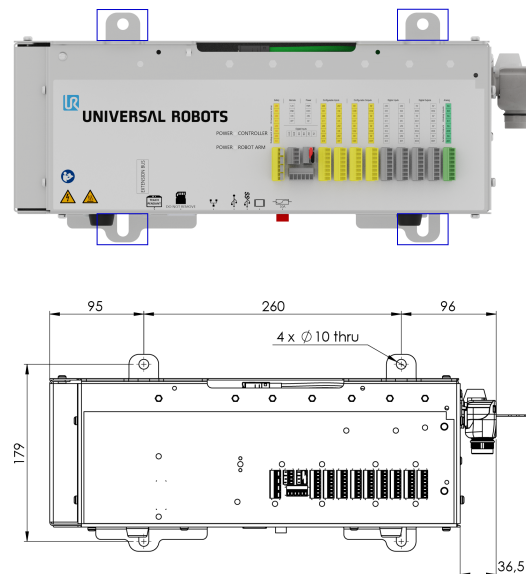

For more product dimensions, see section [9.1 Technical Specifications](#) on page 38.

For more dimensional drawings, see section [9.4 Dimensional Drawings \[mm\]](#) on page 40.

Ensure there is enough space for cables and sufficient air circulation around the Control Box.

A minimum of 50 mm space around the air intake and outlets is recommended, and consideration should be made to avoid re-circulating air.

For more information about the heat dissipation, see [9.3 Control Unit Heat Dissipation on page 39](#). The following illustration shows the airflow.

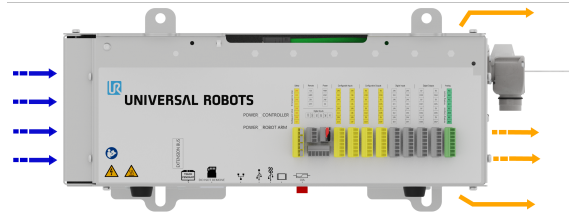

WARNING: HOT SURFACE

Insufficient airflow, or re-circulating warm air, can cause the OEM Control Box to overheat and shut down.

7.2.1. Grounding

Description

The OEM Control Box casing is electrically connected to the ground pin of the power source connector. Any conductive mounting surface must also be connected to the ground.

8. Connecting External Devices

8.1. External Device Connection Ports

Description The bottom side of the OEM Control Box contains a bracket with ports for connecting external devices. The following illustration shows the bracket.

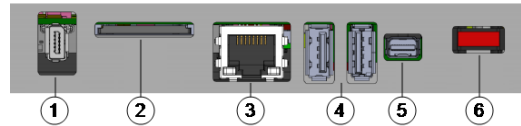

1	Teach Pendant port	2	SD card slot
3	Ethernet port	4	USB ports
5	Mini Displayport	6	10 A mini blade fuse

Ports

Port	Description
Teach Pendant	The port for connecting the Teach Pendant (Teach Pendant sold separately).
Ethernet	Connect external devices supporting MODBUS, Ethernet/IP, or PROFINET.
USB ports	Connect USB devices, for example a mouse, keyboard, a USB flash drive.
Mini Displayport	Connect a monitor. The output video stream shows the same as the display on the Teach Pendant. Supported connection types: <ul style="list-style-type: none"> • DP (direct connection). • Active DVI (using an active DP to DVI converter). • Active HDMI (using an active DP to HDMI converter).
10 A mini blade fuse	Connect a fuse. The fuse must be UL-marked and have a 10 A current rating.
SD card	The SD card is already in the SD card port.



NOTICE

Removing the SD card under operation can corrupt the system. Do not remove the SD card.

Connecting a Mouse, Keyboard, or Monitor

Description Use a USB port to connect a keyboard or a mouse. Use the Mini Displayport to connect a monitor.

8.1.1. How to Connect a Teach Pendant

Description



NOTICE

Do not connect or disconnect the Teach Pendant while Control Box is powered on. This can cause damage to Control Box.



NOTICE

Excessive strain at the port on the OEM Control Box can cause damage to the Teach Pendant connector and affect the functionality of the Teach Pendant.

- Avoid pulling and/or exerting lateral forces on the Teach Pendant cable during installation.
- Avoid moving the Teach Pendant cable connector when it is connected to the Teach Pendant port.

To connect a Teach Pendant:

1. Power down the Control Box. Connect the Teach Pendant cable connector to the Teach Pendant port.
2. The Teach Pendant powers on in a fault state and the Robot Arm brakes engage.
Press **Re-Initialize** to clear the fault state.
3. When the Teach Pendant restarts, on PolyScope, exit the start-up screen.
4. On PolyScope, in the Header, tap **Installation** and select **Safety**.
5. Under Safety, tap **Hardware**.
6. In the Teach Pendant drop-down menu, select **Yes**.

If you are prompted to use a password, type the **Safety Password** and tap **Unlock**.

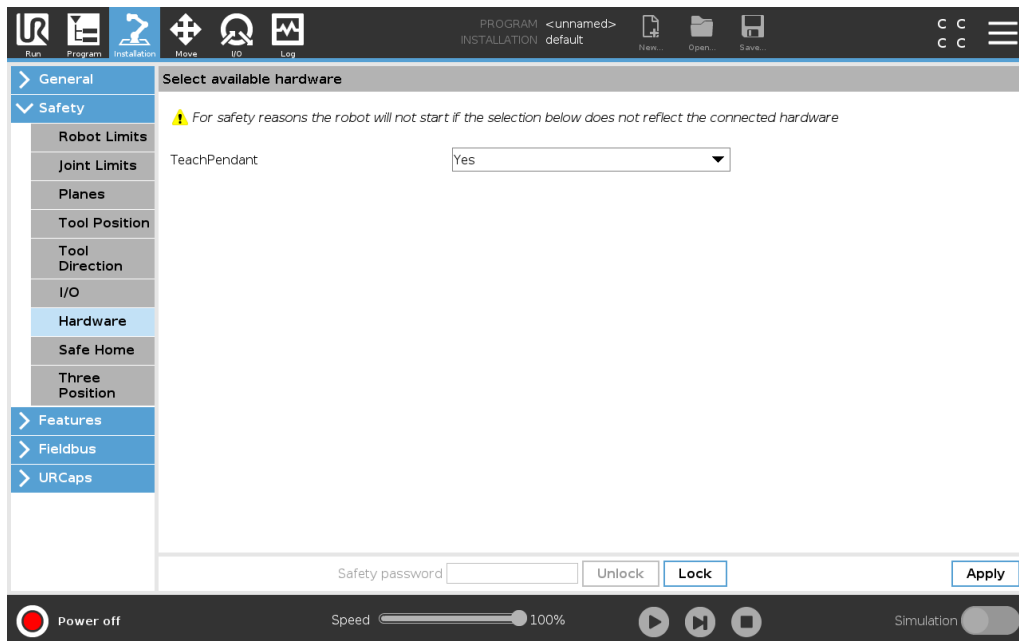

8.1.2. How to Use Remote Control and Local Control

To activate remote control:

1. On PolyScope, in the Header, tap the **Hamburger Menu**.
2. Select **Settings**, tap **System** and select **Remote Control**.
3. On the Remote Control screen, select **Enable** to activate Remote Control.

To activate Local Control, in the **Header**, tap the Remote Control icon and select **Local Control**.

8.2. Connecting Devices

8.2.1. To Connect a 3-Position Enabling Device

Description



NOTICE

The 3PE Teach Pendant is not included with the purchase of the OEM Control Box, so enabling device functionality is not provided. Using a UR20, or a UR30, requires an external enabling device or a 3PE Teach Pendant when programming, or teaching, within the reach of the robot application. See ISO 10218-2.

The OEM Control Box safely supports the following enabling device configurations:

- 3PE Teach Pendant
- External Three-Position Enabling device
- External Three-Position Enabling device and 3PE Teach Pendant

The standard Teach Pendant is not supported by the UR20 and UR30 robots.

The illustration below shows how to connect a Three-Position Enabling device.

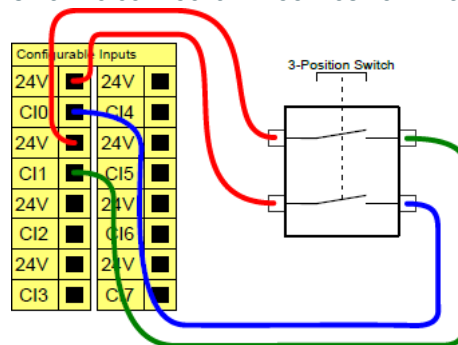

Note: The two input channels for the Three-Position Enabling Device input have a disagreement tolerance of one second.

To connect an Enabling Device to a UR Series robot

or

- Connect a Three-Position Enabling Teach Pendant via the Control Box port (see 8.1 External Device Connection Ports on page 32).
- Connect a Three-Position Enabling Device (see 8.1 External Device Connection Ports on page 32) and an Operational Mode Switch (see 8.1 External Device Connection Ports on page 32).

For complete, in depth information about the electrical configurations, see the Electrical Interface in the UR User Manual available for download at: myur.universal-robots.com/manuals

8.2.2. To Connect an Operational Mode Switch

Description

Using a Three-Position Enabling device requires the use of an Operational Mode switch.

Using a Three-Position Enabling device requires the use of an Operational Mode switch. The illustration below shows how to connect an Operational Mode switch.

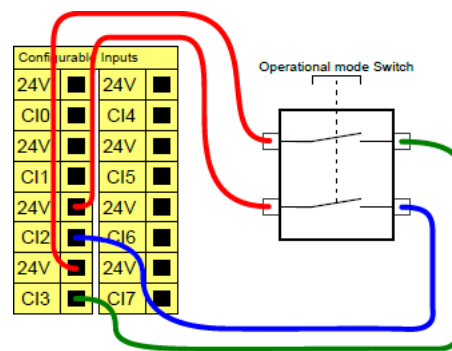

8.3. Remote ON/OFF Control and Emergency Stop

Description

The OEM Control Box requires a remote ON/OFF control and an emergency stop push-button. The following sections describe how to install them using the I/O ports.

8.3.1. Connecting the ON/OFF Control

The images below shows how the remote ON/OFF control is connected.

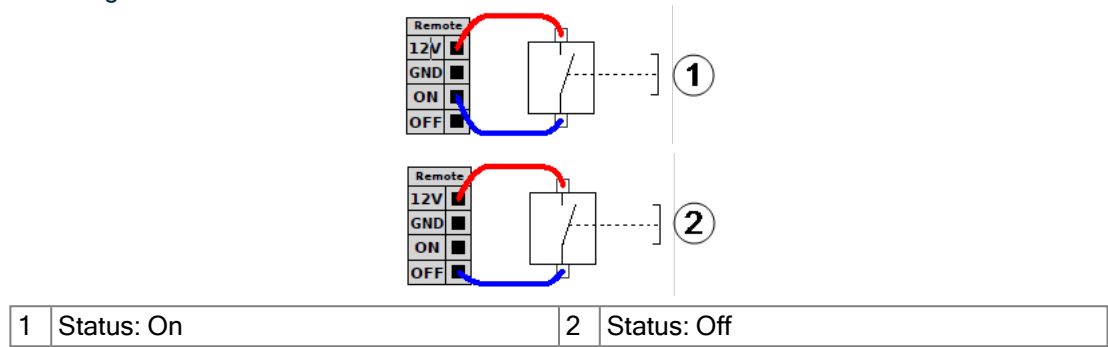

8.3.2. Connecting the Remote Emergency Stop

Description Install an external Emergency Stop (E-stop) if the Teach Pendant with the default Emergency Stop is not connected to the Control Box.

The following illustration shows the minimum required Emergency Stop installation.

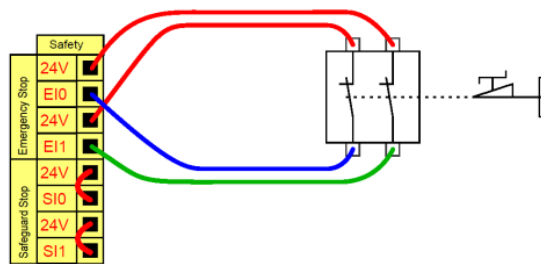

9. OEM Control Box Specifications

9.1. Technical Specifications

Specifications

OEM Control Box size (W x H x D)	451 mm x 150 mm x 168 mm
*OEM AC FlexTail size (W x H x D)	475 mm x 150 mm x 168 mm
*OEM AC FlexTail cable extension bend radius	25 mm
OEM Control Box weight	AC: 4.7 kg (10.4 lbs)
	DC: 4.3 kg (9.5 lbs)
*OEM AC FlexTail weight	AC: 4.9 kg (10.8 lbs)
OEM Control Box I/O ports	16 digital in, 16 digital out, 2 analog in, 2 analog out
OEM Control Box I/O power supply	24 V, max 2 A

* The dimensions differ slightly for the OEM AC FlexTail. There is no difference in functionality between the two types of OEM Control Box.

9.2. Electrical Specifications

AC Variant

Property	Min	Typical	Max	Unit
Input Voltage	90	100 - 240	264	VAC
External Mains Fuse (@ 90-200V)	15	-	16	A
External Mains Fuse (@ 200-265V)	8	-	16	A
Input Frequency	47	-	440	Hz
Stand-by Power	-	-	<1.5	W

DC Variant

Property	Min	Typical	Max	Unit
Input Voltage	19	24 - 48	72	VDC
Stand-by Power	-	-	<7	W
External fuse	-	-	100	A
Inrush current (200)	-	-	400	A

9.3. Control Unit Heat Dissipation

Robot Type	Max. Heat Dissipation
UR20 & UR30	350 W
UR16e & UR10e	130 W
UR5e & UR3e	100 W

9.4. Dimensional Drawings [mm]

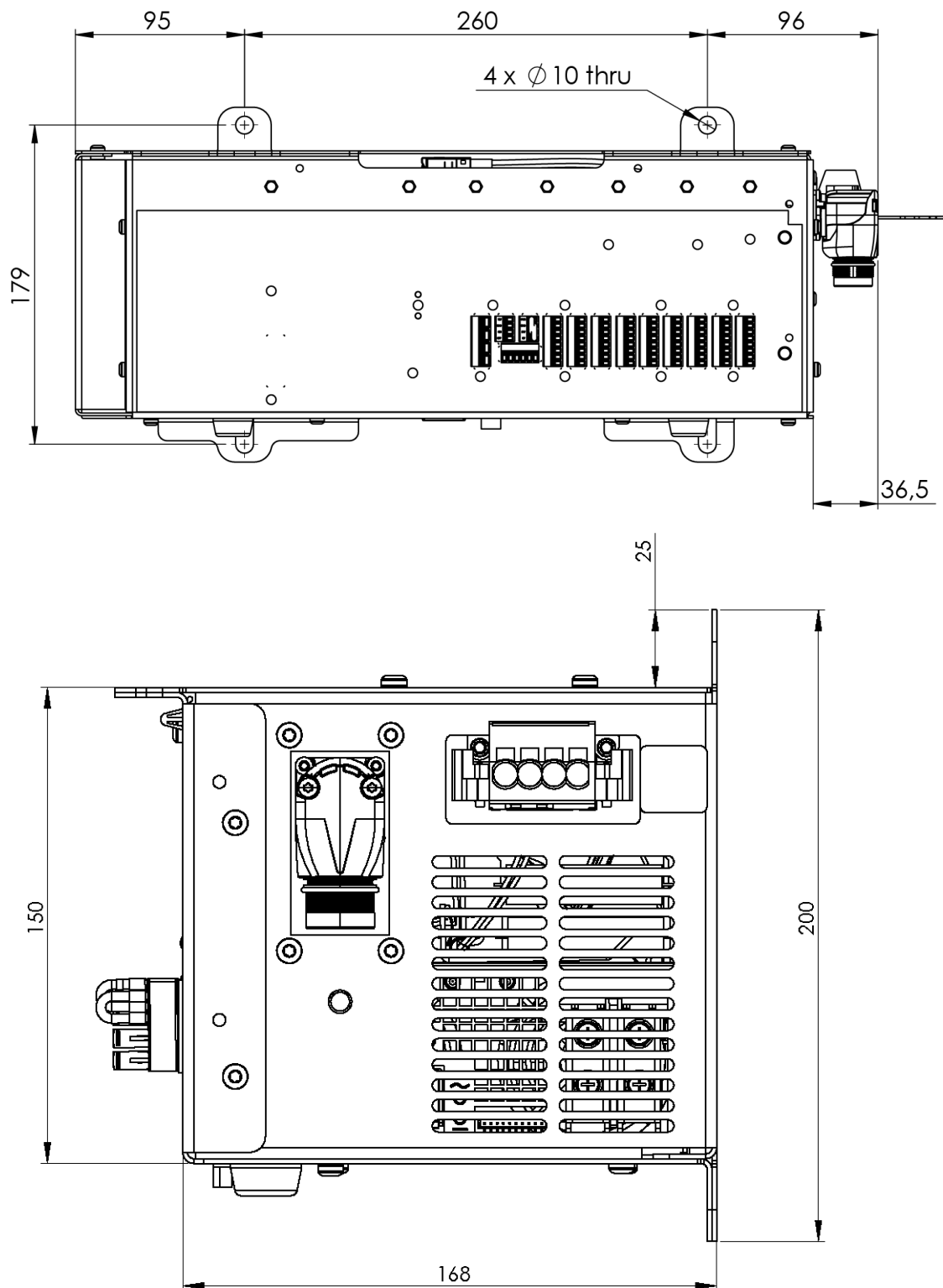

Copyright © 2019-2025 by Universal Robots A/S. All rights reserved.

9.5. Dimensional Drawings [mm] OEM AC FlexTail

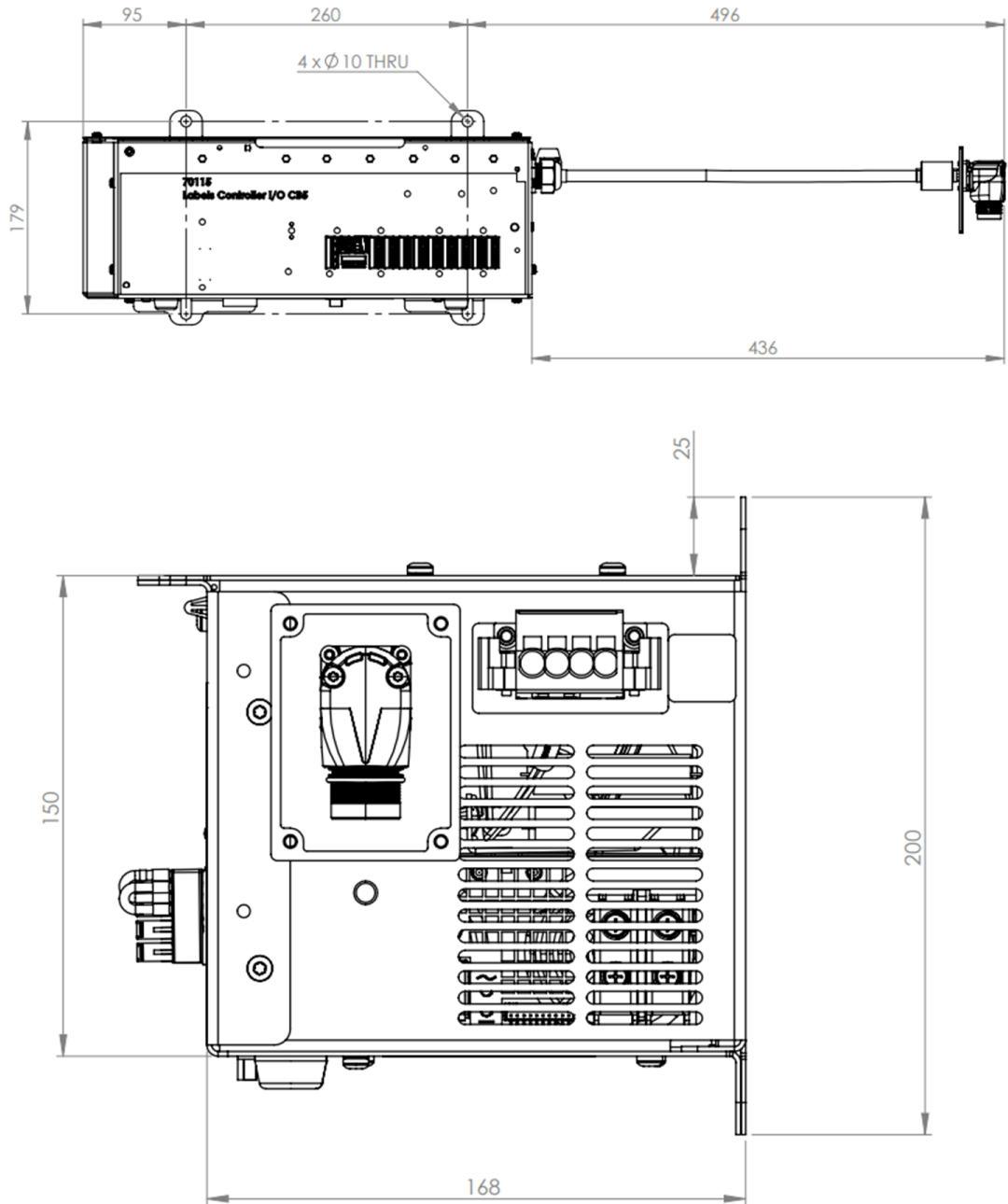

Copyright © 2019-2025 by Universal Robots A/S. All rights reserved.

10. Troubleshooting

10.1. OEM Control Box AC variant

OEM Control Box
AC
&
OEM AC FlexTail

Symptom	Possible Solution
Control Box does not turn on.	Check that the power source is wired correctly (see 4.2 Power Source Wiring: AC on page 17).
Control Box turns on for a few seconds then shuts down.	Pressing the Power ON button for more than 5 seconds shuts the Control Box down. Press the button for 1-2 seconds only.
Robot performance is unstable.	<ul style="list-style-type: none"> • Check the input voltage is within specifications (see 9.1 Technical Specifications on page 38) • Check grounding (avoid ground-loops or loose screws).

10.2. OEM Control Box DC variant

OEM Control
Box DC

Symptom	Possible Solution
Control Box does not turn on.	<ul style="list-style-type: none"> • Check that the power source is wired correctly (see 6.2 Power Source Wiring: DC on page 26). • Ensure the DC source connection polarity is correct. Reverse polarity causes permanent damage to the OEM Control Box.
Control Box turns on for a few seconds then shuts down.	Pressing the Power ON button for more than 5 seconds shuts the Control Box down. Press the button for 1-2 seconds only.
Control Box does not turn on or the robot performance is unstable.	<ul style="list-style-type: none"> • Check the DC input is within specifications in 9.1 Technical Specifications on page 38. • Check the DC supply has enough charge to supply the initial current to the system.

For complete, in depth information about the electrical configurations, see the Electrical Interface in the UR User Manual available for download at: myur.universal-robots.com/manuals

11. Robot Arm Cleaning and Inspection

Description As part of regular maintenance the robot arm can be cleaned, in accordance with the recommendations in this manual and local requirements.

Cleaning Methods To address the dust, dirt, or oil on the robot arm and/or Teach Pendant, simply use a cloth alongside one of the cleaning agents provided below.

Surface Preparation: Before applying the below solutions, surfaces may need to be prepared by removing any loose dirt or debris.

Cleaning agents:

- Water
- 70% Isopropyl alcohol
- 10% Ethanol alcohol
- 10% Naphtha (Use to remove grease.)

Application: The solution is typically applied to the surface that needs cleaning using a spray bottle, brush, sponge, or cloth. It can be applied directly or diluted further depending on the level of contamination and the type of surface being cleaned.

Agitation: For stubborn stains or heavily soiled areas, the solution may be agitated using a brush, scrubber, or other mechanical means to help loosen the contaminants.

Dwell Time: If necessary, the solution is allowed to dwell on the surface for a up to 5 minutes to penetrate and dissolve the contaminants effectively.

Rinsing: After the dwell time, the surface is typically rinsed thoroughly with water to remove the dissolved contaminants and any remaining cleaning agent residue. It's essential to ensure thorough rinsing to prevent any residue from causing damage or posing a safety hazard.

Drying: Finally, the cleaned surface may be left to air dry or dried using towels.



WARNING

DO NOT USE BLEACH in any diluted cleaning solution.

**WARNING**

Grease is an irritant and can cause an allergic reaction. Contact, inhalation or ingestion can cause illness or injury. To prevent illness or injury, adhere to the following:

- **PREPARATION:**
 - Ensure that the area is well ventilated.
 - Have no food or beverages around the robot and cleaning agents.
 - Ensure that an eye wash station is nearby.
 - Gather the required PPE (gloves, eye protection)
- **WEAR :**
 - Protective gloves: Oil resistant gloves (Nitrile) impermeable and resistant to product.
 - Eye protection is recommended to prevent accidental contact of grease with eyes.
- **DO NOT INGEST.**
- In the event of
 - contact with skin, wash with water and a mild cleaning agent
 - a skin reaction, get medical attention
 - contact with the eyes, use an eyewash station, get medical attention.
 - inhalation of vapors or ingestion of grease, get medical attention
- After grease work
 - clean contaminated work surfaces.
 - dispose responsibly of any used rags or paper used for cleaning.
- Contact with children and animals is prohibited.



Robot Arm Inspection Plan

The table below is a checklist of the type of inspections recommended by Universal Robots. Perform inspections regularly as advised in the table. Any referenced parts found to be in an unacceptable state must be rectified or replaced.

Inspection action type			Timeframe		
			Monthly	Biannually	Annually
1	Check flat rings	V		X	
2	Check robot cable	V		X	
3	Check robot cable connection	V		X	
4	Check Robot Arm mounting bolts *	F	X		
5	Check Tool mounting bolts *	F	X		
6	Round Sling	F			X

**Robot Arm
Inspection
Plan****NOTICE**

Using compressed air to clean the robot arm can damage the robot arm components.

- Never use compressed air to clean the robot arm.

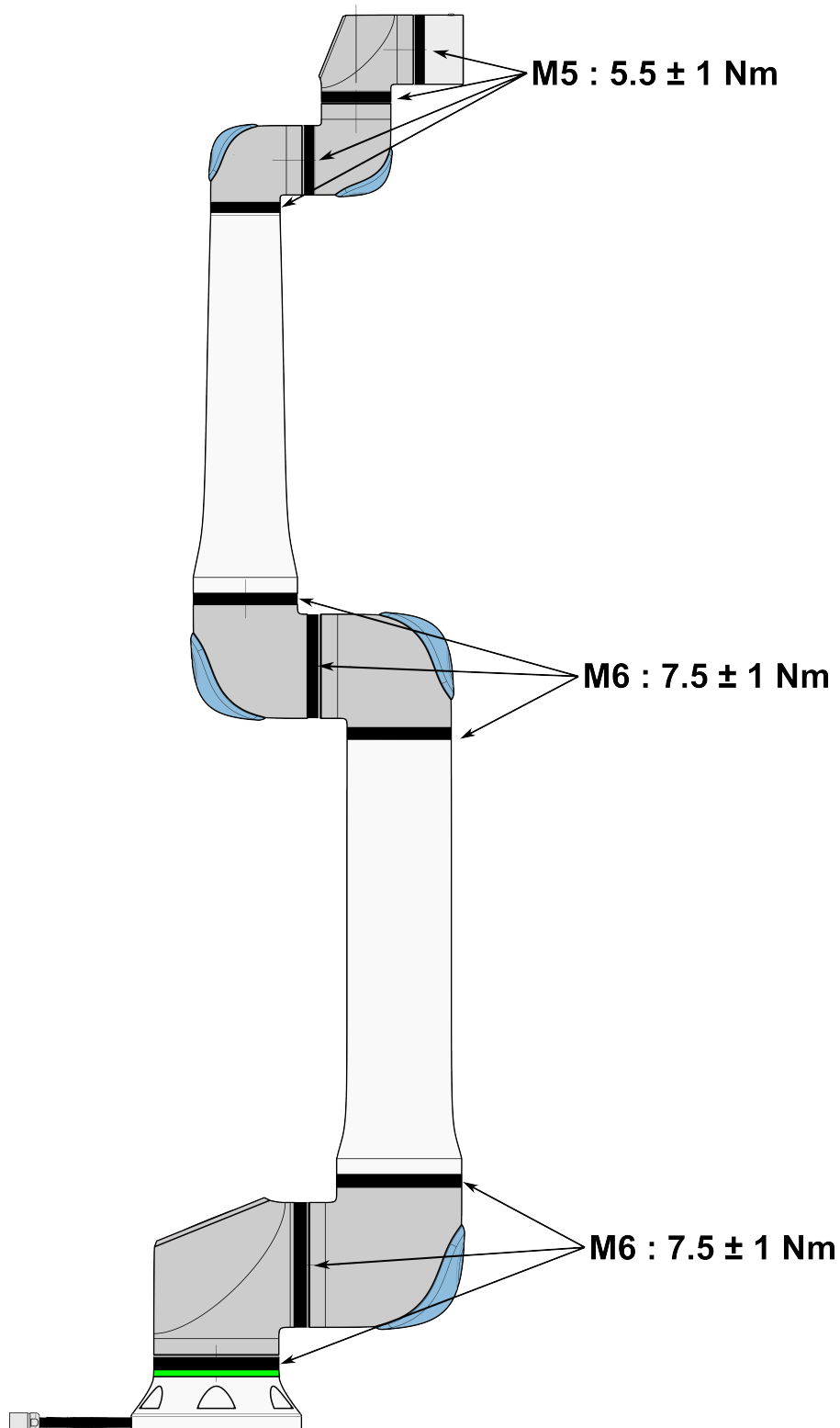

Robot Arm Inspection Plan

1. Move the Robot Arm to ZERO position, if possible.
2. Turn off and disconnect the power cable from Control Box.
3. Inspect the cable between Control Box and Robot Arm for any damage.
4. Check the base mounting bolts are properly tightened.
5. Check the tool flange bolts are properly tightened.
6. Inspect the flat rings for wear and damage.
 - Replace the flat rings if they are worn out or damaged.



NOTICE

If any damage is observed on a robot within the warranty period, contact the distributor where the robot was purchased.

Inspection

1. Unmount any tool/s or attachment/s or set the TCP/Payload/CoG according to tool specifications.
2. To move the robot arm in Freedrive:
 - On a 3PE Teach Pendant, rapidly light-press, release, light-press again and keep holding the 3PE button in this position.

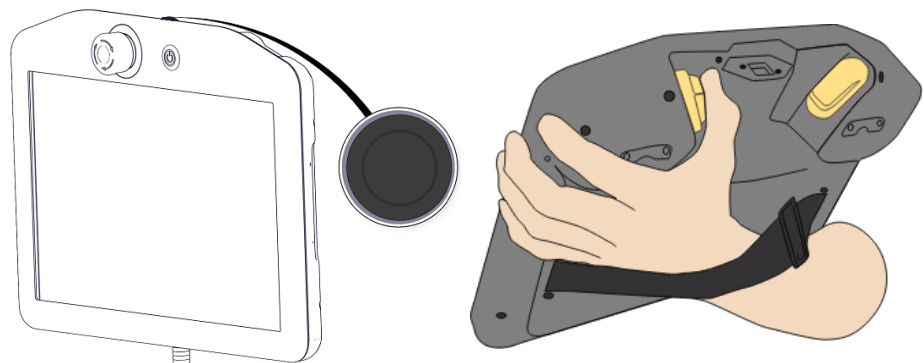

Power button

3PE button

3. Pull/Push the robot to a horizontally elongated position and release.

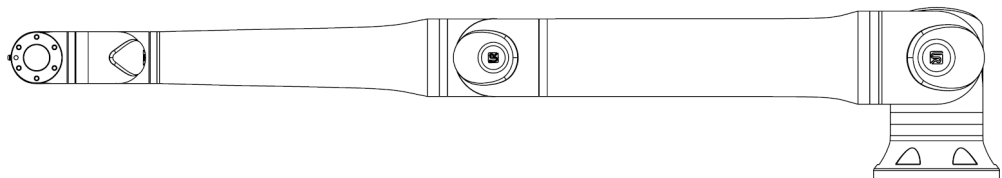

4. Verify the robot arm can maintain the position without support and without activating Freedrive.

12. Cable Strain Relief Bracket

Description

You can prevent cable strain in your OEM Control Box by installing a cable strain relief bracket. The bracket provides cable strain relief when the Teach Pendant is in use, under normal operation.

12.1. OEM Control Box AC

To install and use the cable strain relief bracket

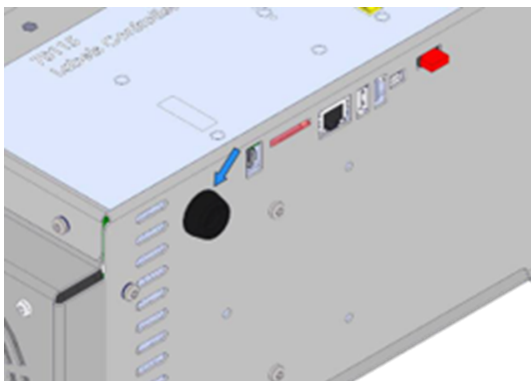

1. Remove grommet

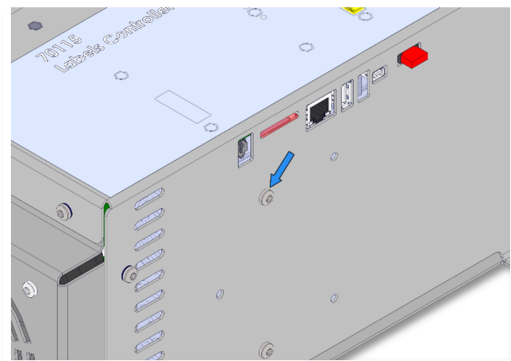

2. Remove screw

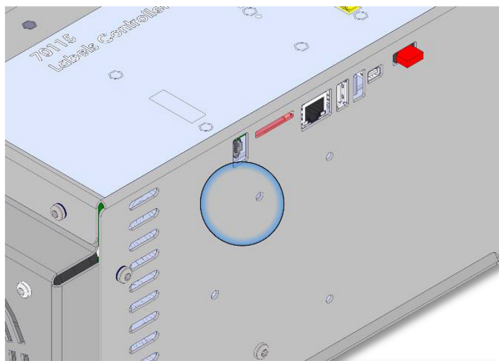

3. Clean area with alcohol solution and allow the alcohol to evaporate

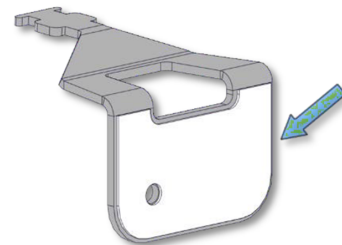

4. Remove protective film from adhesive patch

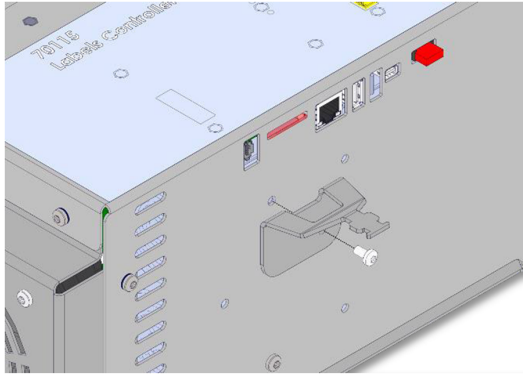

5. Align the bracket using the included screw

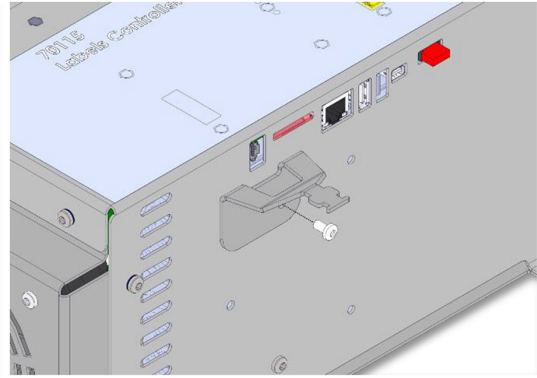

6. Tighten the included screw (Torque 1Nm)

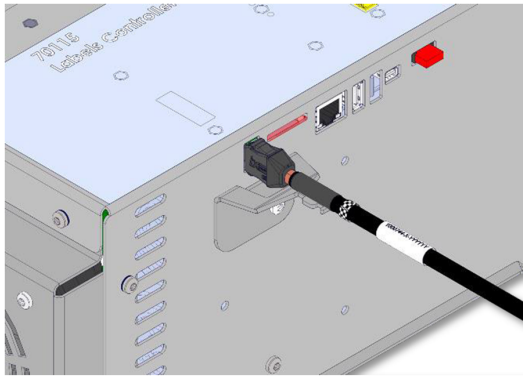

7. Connect TP cable

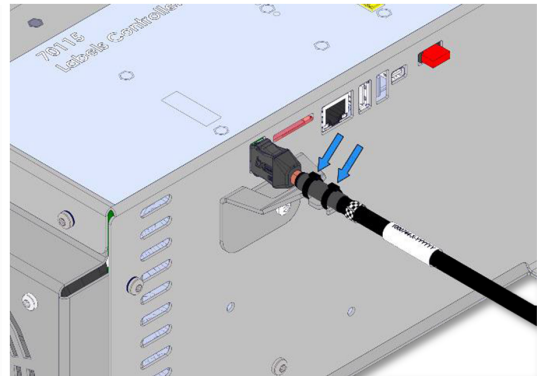

8. Secure the TP cable with the included zip ties

12.2. OEM Control Box DC

To install and use the cable strain relief bracket

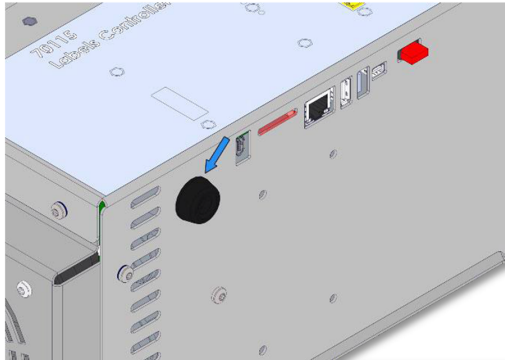

1. Remove grommet

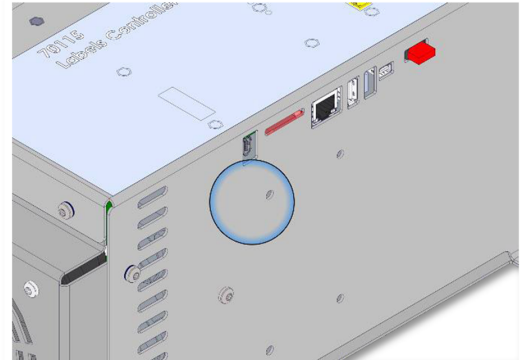

2. Clean area with alcohol solution and allow the alcohol to evaporate.

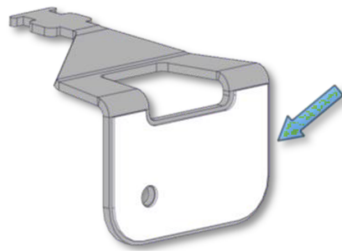

3. Remove protective film from adhesive patch

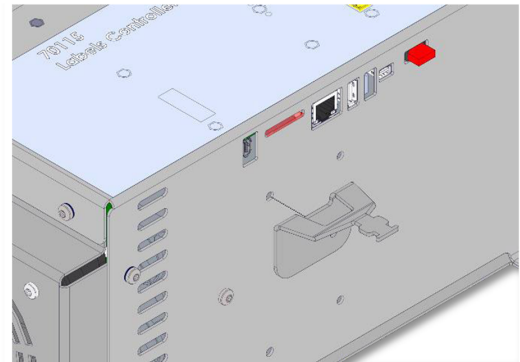

4. Align the bracket using the screw hole

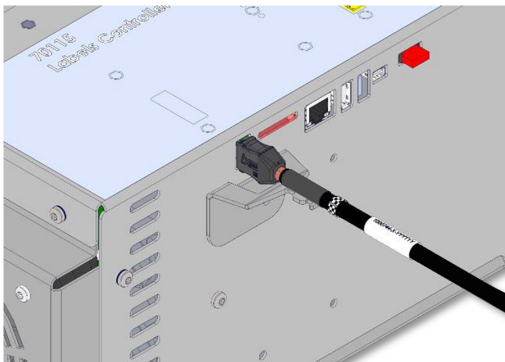

5. Connect TP cable

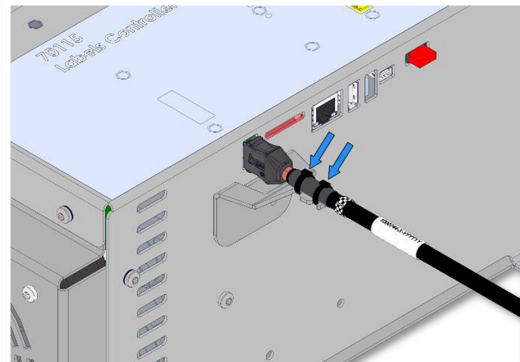

6. Secure the TP cable with the included zip ties

13. Certifications

Description	This section contains information about certificates and declarations valid for Universal Robots robots with OEM controllers.
Shipping materials	As stated by our suppliers, Universal Robots robots shipping materials comply with the ISPM-15 requirements for producing wood packaging material and are marked accordingly.
Certification of quality	Universal Robots robots undergo continuous internal testing and end-of-line test procedures. UR testing processes undergo continuous review and improvement.
Declarations according to EU directives	Universal Robots robots are certified according to the following directives. <ul style="list-style-type: none">• 2006/42/EC - Machinery Directive (MD) According to the Machinery Directive 2006/42/EC, Universal Robots robots are partly completed machinery, and do not have a CE mark on them.• 2012/19/EU - Waste of Electrical and Electronic Equipment (WEEE) For information on disposal of electrical and electronic equipment waste, refer to chapter 7, Disposal and Environment in the robot user manual.

Software Name: PolyScope 5
Software Version: 5.23
Document Version: 10.14.150



716-197-00



716-197-00