



UNIVERSAL ROBOTS

Service Handbook

UR3e UR5e UR7e

UR10e UR12e UR16e

e-Series Control box

OEM Control Box



Contents

1. Copyright and Disclaimers	6
2. Introduction	1
2.1. About This Document	1
2.2. Company Details	1
2.3. Copyright, Warranty and Disclaimers	2
2.4. Safety Message Types	2
3. Handling Electrostatic Discharge (ESD)-Sensitive Parts	4
4. Recommended Inspection Activities	11
4.1. Robot Arm	11
4.1.1. Inspection Plan	11
4.1.2. Visual Inspection: Robot arm	12
4.1.3. Functional Inspection	13
4.1.4. Cleaning Your Robot	13
4.2. Control Box and Teach Pendant	14
4.2.1. Inspection Plan	14
4.2.2. Functional and Safety Inspection	15
4.2.3. Visual Inspection: Control Box	18
4.2.4. Cleaning	19
5. Service and Replacement of Parts	20
5.1. Pre-Use Assessment	20
5.1.1. Recommended Tools	21
5.2. Robot Arm	22
5.2.1. Movement Without Drive Power	23
5.2.2. General Guidance to Separate Joint from Counterpart	24
5.2.3. Joint Connection Types	26
5.2.4. Torque Values	27
5.2.5. Power and Communication Connector Types on the Joint	28
5.2.6. Connector Location on Joints	31
5.2.7. Screw Connection	35
5.2.8. Clamp Connection	41
5.2.9. Tool Flange	45
5.2.10. Joint Verification	46
5.2.11. Zeroing of Joints	47
5.2.12. Dual Robot Calibration	52
5.2.13. Program Correction by Key Waypoints	52
5.3. Robot Cable	53
5.3.1. Replacing Robot Cable	53



- 5.4. Control Box 55
 - 5.4.1. Dismantling the Control Box 55
 - 5.4.2. Dismantling the OEM AC and DC Control Box 59
 - 5.4.3. Torque Values 65
 - 5.4.4. Replacing the Teach Pendant: Standard TP 68
 - 5.4.5. Replacing the Teach Pendant: 3PE TP 70
 - 5.4.6. Replacement of Teach Pendant Cable 72
- 6. Software 78**
 - 6.1. Long Term Support 78
 - 6.2. Software Updates 78
 - 6.2.1. Update Procedure 79
 - 6.2.2. Update Timeline 82
 - 6.2.3. Downgrading vs. Restoring System Backup 83
 - 6.3. Using Support File 84
 - 6.4. Using Magic Files 86
 - 6.5. Backup of Data 86
 - 6.5.1. Hardware Requirements 87
 - 6.5.2. Software Requirements 87
 - 6.5.3. How to Access Linux Partition from Windows 88
 - 6.5.4. Copy the Data from SD Card 88
- 7. Troubleshooting 90**
 - 7.1. Adding External Equipment for Troubleshooting Purpose 90
 - 7.2. Log Viewer 90
 - 7.2.1. General Purpose 90
 - 7.2.2. Log Viewer Requirements 91
 - 7.2.3. Installation Log Viewer 91
 - 7.2.4. How to Use the UR Log Viewer 92
 - 7.2.5. Loading the Data 92
 - 7.2.6. Log Reader Tab 93
 - 7.2.7. Flight Records 94
 - 7.2.8. Log Start 97
 - 7.2.9. Log Analysis Tab 98
 - 7.2.10. Record Data Tab 99
 - 7.2.11. Export From Robot Tab 101
 - 7.2.12. Types of Messages 101
 - 7.3. Support Log Reader (SLR) 102
 - 7.4. LED Indicators and Fuse on Safety Control Board 104
 - 7.4.1. LED Indicators on Safety Control Board 104
 - 7.4.2. Fuse 104
 - 7.5. Complete Rebooting Sequence 106

7.6. Protective Stop	107
7.6.1. Preventive Measures	107
8. Electrical Drawings	109
9. Spare Parts	110
10. Packing and Shipping of Robot/Spare Parts	111
10.1. Transport Without Packaging	113

1. Copyright and Disclaimers

The information contained herein is the property of Universal Robots A/S and shall not be reproduced in whole or in part without prior written approval of Universal Robots A/S. The information herein is subject to change without notice and should not be construed as a commitment by Universal Robots A/S. This document is periodically reviewed and revised. Universal Robots A/S assumes no responsibility for any errors or omissions in this document.

Copyright © 2009-2025 by Universal Robots A/S.

The Universal Robots logo is a registered trademark of Universal Robots A/S.



NOTICE

Universal Robots continues to improve reliability and performance of its products, and therefore reserves the right to upgrade the product without prior warning. Universal Robots takes care that the content of this document is precise and correct, but takes no responsibility for any errors or missing information.



NOTICE

Universal Robots disclaims any liability, even if all guidelines in this document are followed.

2. Introduction

2.1. About This Document

Purpose

The purpose of this service manual is to help Universal Robots (UR) users and integrators to safely perform service-related operations and troubleshooting. [GAB. Per *Chicago Manual of Style's* (CMS) preference for the sparing use of capitals, referred to as down style. GAB]

Universal Robots industrial robots are designed using high-quality components to ensure long product life cycle. However, improper use of a robot or robot parts will cause failures. If, for example, the robot is overloaded, dropped during relocation, damaged by collision or any other improper use, the warranty will be void.

Universal Robots recommends the user *not* to repair, adjust, or make other interventions in the mechanical or electrical systems of the robot without first consulting a UR-certified service engineer. Any unauthorized repair and/or troubleshooting work(s) voids the warranty. Service-related operations and troubleshooting should only be performed by qualified personnel.

Before performing service-related operations, stop the robot program and disconnect the main power to any potential dangerous tool on the robot or its surroundings.

In the event of a defect, Universal Robots recommends ordering new parts from the Universal Robot distributor where the robot was originally purchased. Alternately, parts can be ordered from the nearest distributor, details of which can be obtained from Universal Robots official website at www.universal-robots.com.

2.2. Company Details

Where we are

Universal Robots A/S
Energivej 51
DK-5260 Odense Denmark
Tel.: +45 89 93 89 89
Fax: +45 38 79 89 89

2.3. Copyright, Warranty and Disclaimers

The information contained herein is the property of Universal Robots A/S and shall not be reproduced in whole or in part without prior written approval of Universal Robots A/S. The information herein is subject to change without notice and should not be construed as a commitment by Universal Robots A/S. This document is periodically reviewed and revised.

Universal Robots A/S assumes no responsibility for any errors or omissions in this document.

Copyright © 2009-2025 by Universal Robots A/S.

The Universal Robots logo is a registered trademark of Universal Robots A/S.



NOTICE

Universal Robots continues to improve reliability and performance of its products, and therefore reserves the right to upgrade the product without prior warning. Universal Robots takes care that the content of this document is precise and correct, but takes no responsibility for any errors or missing information.



NOTICE

Universal Robots disclaims any liability, even if all guidelines in this document are followed.



NOTICE

The product is covered under the Standard Warranty as detailed in the Standard Warranty document.

You can see the Standard Warranty document here: [Standard Warranty](#)

2.4. Safety Message Types

Safety Signs Safety messages and statements are used throughout this manual to emphasize important information.
Read all messages and statements to help ensure safety and to prevent injury to personnel and product damage.
The safety message types are defined below.

**WARNING**

Indicates a hazardous situation which, if not avoided, could result in death or serious injury.

**WARNING: ELECTRICITY**

Indicates a hazardous electrical situation which, if not avoided, could result in death or serious injury.

**WARNING: HOT SURFACE**

Indicates a hazardous hot surface where injury can result from contact and non-contact proximity.

**CAUTION**

Indicates a hazardous situation which, if not avoided, could result in injury.

**GROUND**

Indicates grounding.

**PROTECTIVE GROUND**

Indicates protective grounding.

**NOTICE**

Indicates the risk damage to equipment and/or useful information that should be particularly noted.

**READ MANUAL**

Indicates more detailed information that should be consulted in the manual.



3. Handling Electrostatic Discharge (ESD)-Sensitive Parts



Figure 1.0
PCB, an ESD-sensitive part

To prevent damage to ESD-sensitive parts, that is, printed circuit board (PCB), follow the instructions below in addition to all the usual precautions, such as turning off the power before removing the PCB. See section [Complete Rebooting Sequence](#).



NOTICE

Be sure you have intact ESD wristband and a spare ESD bag before replacing any ESD-sensitive parts.

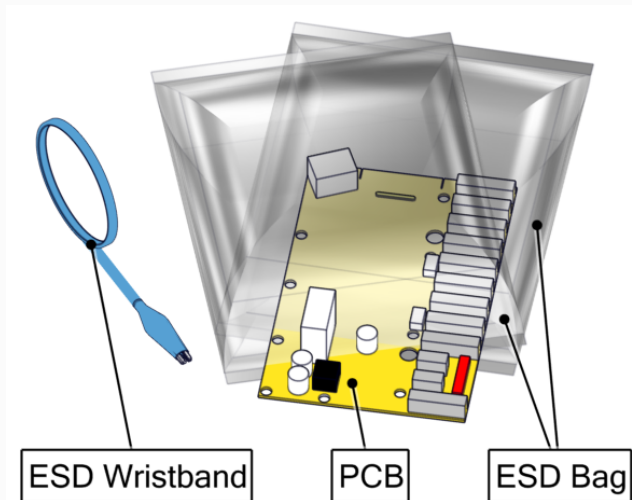

Figure 1.1
ESD wristband, PCB, ESD bag



NOTICE

Keep the ESD-sensitive part in its original shipping container (a special "ESD bag") until the part is ready to be installed.

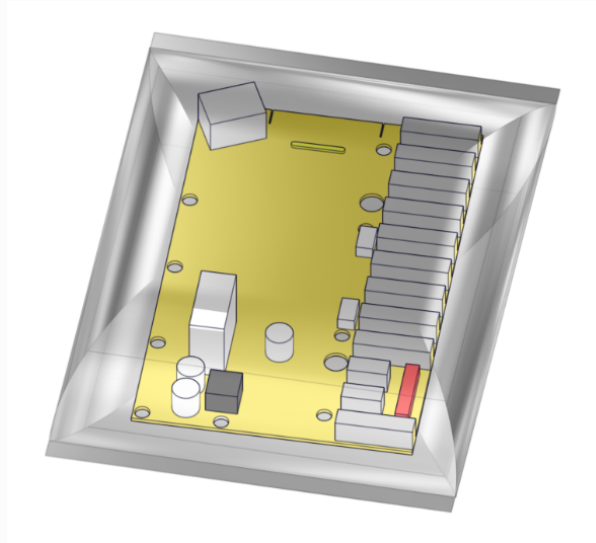

Figure 1.2
ESD bag



NOTICE

Put the ESD wristband on your wrist. Connect the wristband to the system ground point. It discharges any static electricity in your body to ground.



NOTICE

Replacing an ESD-sensitive part in a safe way is important to avoid damage to the part. It is important to take precautions when handling an ESD-sensitive part.

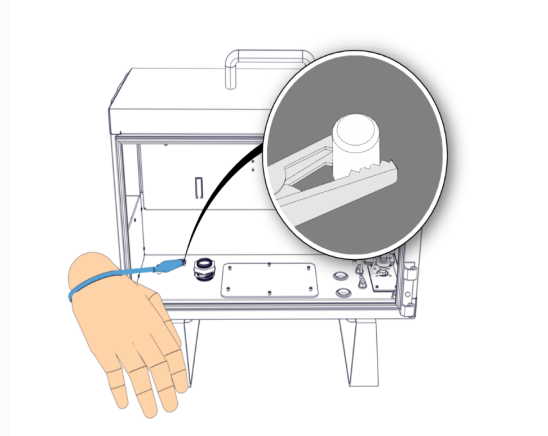

Figure 1.3. ESD wristband connection to the system ground



NOTICE

Hold the ESD-sensitive part by its edges. Do not touch its pins or hold directly on any exposed prints.

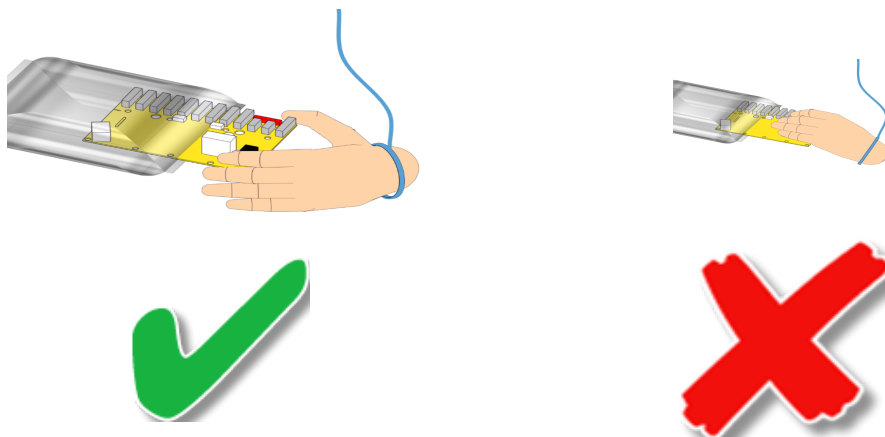

Figure 1.4 Correct and incorrect PCB handling



NOTICE

First place the OLD part in the spare ESD bag, then take out the NEW part of the ESD bag.

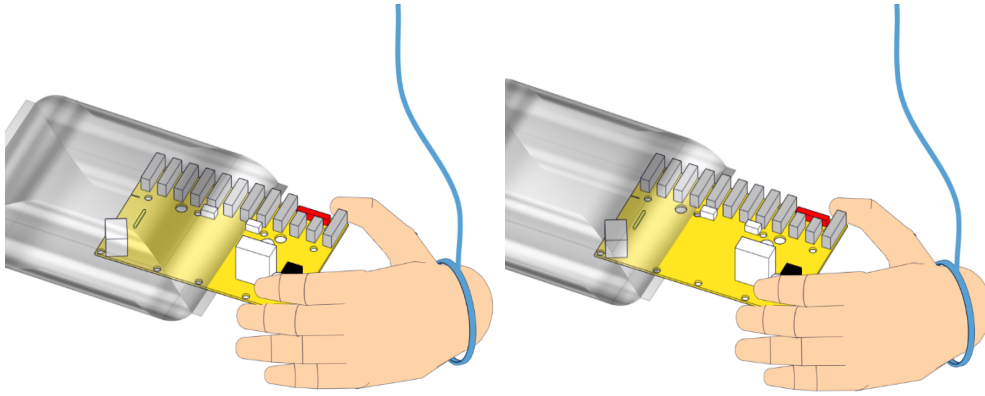

Figure 1.5. Correct PCB handling



NOTICE

Do not place the ESD-sensitive part on nonconductive material or on metal tables/surfaces. If you must put down the ESD-sensitive part for any reason, then first place it into the ESD bag.

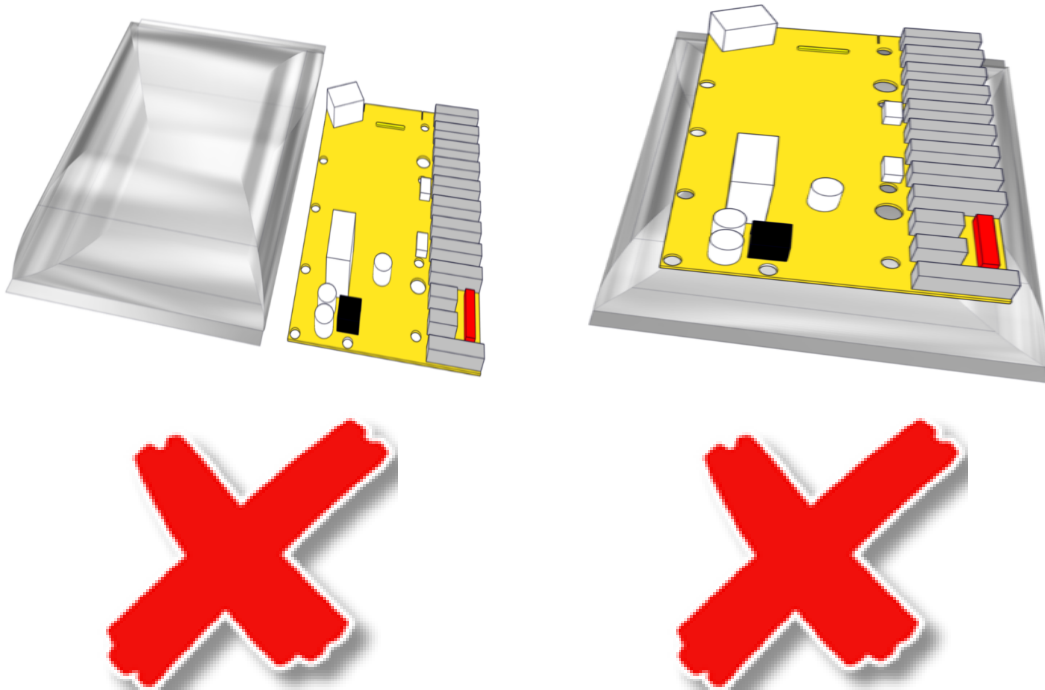

Figure 1.7. Wrong placement of ESD-sensitive part



NOTICE

Machine covers and metal tables/surfaces are electrical grounds. They increase the risk of damage because they make a discharge path from your body through the ESD-sensitive part. (Large metal objects can be discharge paths without being grounded.)

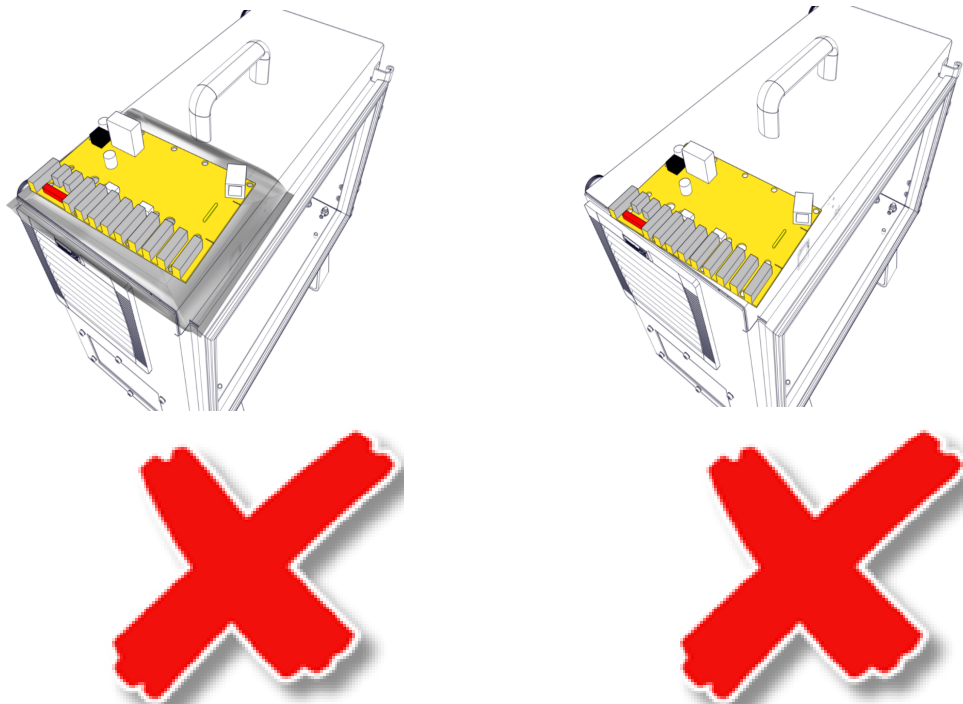

Figure 1.8. Wrong placement of ESD-sensitive part in metallic surface



NOTICE

If handing an ESD-sensitive part to another person, ensure both are wearing ESD wristband, attached to the system ground point.

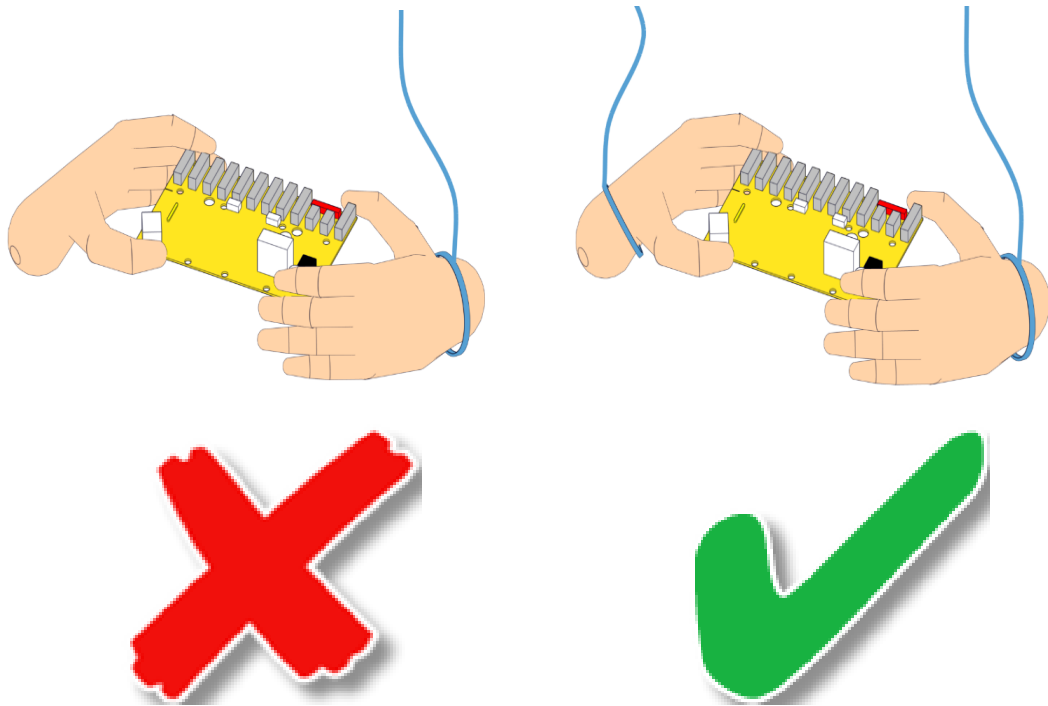

Figure 1.9. Improper and proper handling of PCB to another user.



NOTICE

Extra care is needed when working with ESD-sensitive parts during cold weather and when heating is used, because low air humidity increases accumulation of the static electricity.

4. Recommended Inspection Activities

This chapter provides graphic and tabular information about UR robots inspection activities for:

- Robot arm
- Control box
- Teach pendant

4.1. Robot Arm

4.1.1. Inspection Plan

UR inspection types

The table below is a checklist of the type of inspections recommended by Universal Robots. Perform inspections regularly as advised in the table. Any referenced parts found to be in an unacceptable state must be rectified or replaced.

See the following sections for detailed guidance:

- [4.1.2 Visual Inspection: Robot arm on the next page](#)
- [5.1 Pre-Use Assessment on page 20](#)
- [5.2 Robot Arm on page 22](#)

Inspection action type			Timeframe		
			Monthly	Biannually	Annually
1	Check blue lids *	V		X	
2	Check blue lid screws	F		X	
3	Check flat rings	V		X	
4	Check robot cable	V		X	
5	Check robot cable connection	V		X	
6	Check Robot Arm mounting bolts *	F	X		
7	Check Tool mounting bolts *	F	X		
8	Check screws/bolts on joints *	F		X	

V = Visual inspection F = Functional inspection * = Must also be checked after heavy collision

4.1.2. Visual Inspection: Robot arm



NOTICE

Using compressed air to clean the robot arm can damage the robot arm components.

- Never use compressed air to clean the robot arm.



NOTICE

If any damage is observed on a robot within the warranty period, contact the distributor where the robot was purchased.

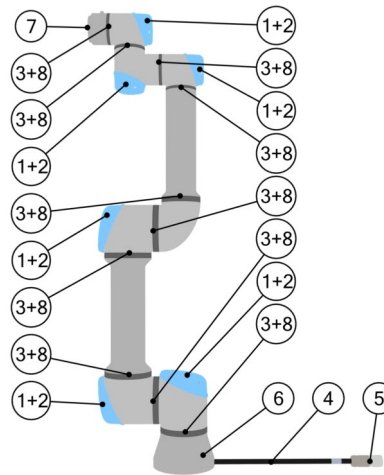

1. Move the Robot Arm to ZERO position, if possible.
2. Turn off and disconnect the power cable from Control Box.
3. Inspect the cable between Control Box and Robot Arm for any damage.
4. Check the base mounting bolts are properly tightened.
5. Check the tool flange bolts are properly tightened.
6. Inspect the flat rings for wear and damage.
 - Replace the flat rings if they are worn out or damaged.
7. Inspect the blue lids on all the joints for any cracks or damage.
 - Replace the blue lids if they cracked or damaged.
8. Inspect the screws used for the blue lids are in place and properly tightened.
 - Replace or tighten screws, if necessary.
 - Correct the torque value for screws on the blue lids to 0.4 Nm $\begin{matrix} +0.05Nm \\ -0.05Nm \end{matrix}$

4.1.3. Functional Inspection

Do functional inspections to ensure the robot arm and its screws, bolts and tools are not loose.

Use a correctly calibrated torque wrench, specified in [Torque Values](#) to check the screws and bolts listed in the inspection plan.

4.1.4. Cleaning Your Robot

Everyday cleaning

You can wipe away any dust/dirt/oil observed on the robot arm and/or teach pendant using a cloth and one of the following cleaning agents:

1. water
2. 70% isopropyl alcohol
3. 10% ethanol alcohol
4. 10% naphtha

In rare cases, very small amounts of grease can be visible from the joint. This does not affect the function, use, or durability of the joint.

Additional cleaning

Due to the added focus on cleaning your robot, Universal Robots recommends cleaning with 70% isopropyl alcohol (rubbing alcohol).

1. Wipe the robot with a hard twisted micro fiber cloth and 70% isopropyl alcohol (rubbing alcohol).
2. Let the 70% isopropyl alcohol dwell on the robot for 5 minutes, and then clean the robot using standard cleaning procedure.

Do not use bleach Do not use bleach in any diluted cleaning solution.

4.2. Control Box and Teach Pendant

4.2.1. Inspection Plan

Inspection checklist

Table 2.0 below is a checklist of the type of inspections recommended by Universal Robots. Perform inspections regularly as stated in the table. Any referenced parts found to be in an unacceptable state must be corrected or replaced.

See the following sections for detailed guidance:

- [4.2.2 Functional and Safety Inspection on the facing page](#)
- [4.1.2 Visual Inspection: Robot arm on page 12](#)
- [5.1 Pre-Use Assessment on page 20](#)

Inspection action type			Time Frame		
			Monthly	Biannually	Annually
1	Check emergency stop on teach pendant	F	X		
2 & 3	On a standard TP: check the freedrive button by pressing it gently. On a 3PE TP: check the 3PE buttons pressing them gently.	F		X	
	Check backdrive mode	F	X		
	Check freedrive mode	F		X	
4	Check safety inputs and outputs(if connected)	F	X		
5	Check teach pendant cable and connector	V		X	
6	Check and clean air filters on control box	V	X		
7	Check terminals in control box	F		X	
8 & 9	Check electrical grounding <1Ω to control box	F			X
	Check main power to control box	F			X

V = Visual inspection F = Functional inspection

4.2.2. Functional and Safety Inspection



NOTICE

Robot safety functions is highly recommended to be tested monthly to ensure correct function.

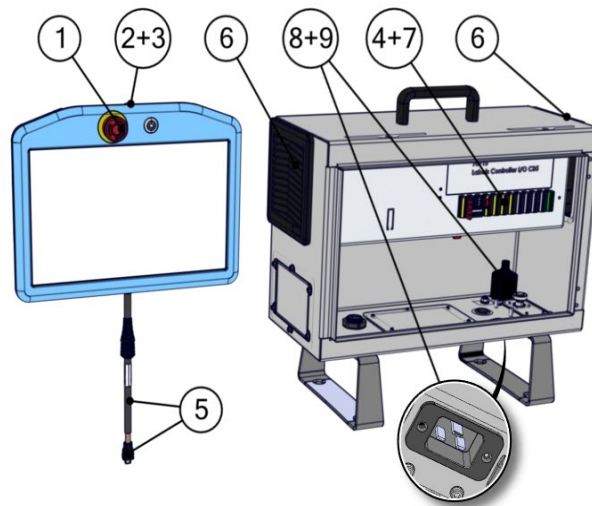

Figure 3.1
Numbered instruction per parts of teach pendant.

Emergency stop button on the teach pendant:

1. Press the emergency stop button of the teach pendant. See figure 3.2.
2. Observe the robot stops and shuts off power to the joints.
3. Power on robot again.

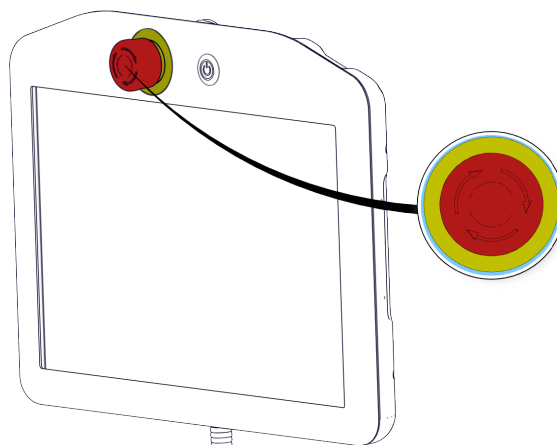
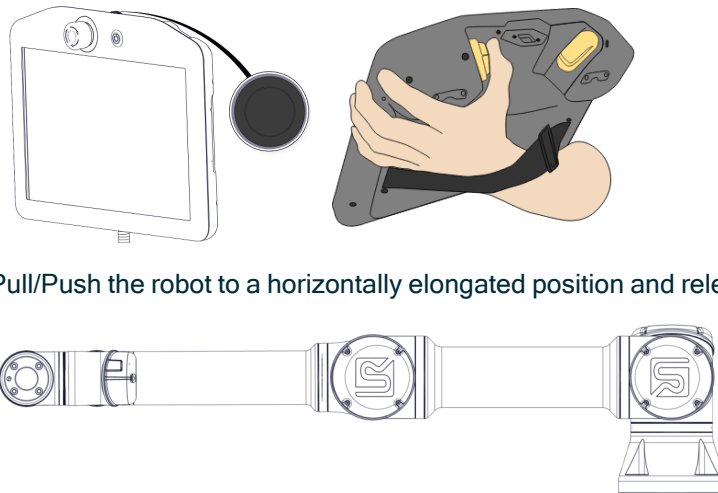

Figure 3.2
Emergency button of teach pendant.

Freedrive

1. Unmount attachment or set tool center point (TCP)/payload/CoG (center of gravity) according to tool specifications.
2. To move the robot arm in freedrive, see figure 3.3 below.

<p>Standard TP</p> <p>On a standard teach pendant (TP), press and hold the freedrive button.</p>	<p>3PE TP</p> <p>On a 3-position enabling teach pendant (3PE TP), rapidly light-press, release, light-press again, and keep holding the 3PE button in this position</p>
---	--



3. Pull/Push the robot to a horizontally elongated position and release. See figure 3.4.

Figure 3.4. Elongated horizontal position of UR robot.

4. Verify the robot arm can maintain the position without support and without pressing the freedrive or 3PE button.

Backdrive

If the robot arm is close to colliding with something, you can use the backdrive function to move the robot arm to a safe position before (re)initializing it.

1. Press *On* to enable power. Status changes to *Robot Active*.

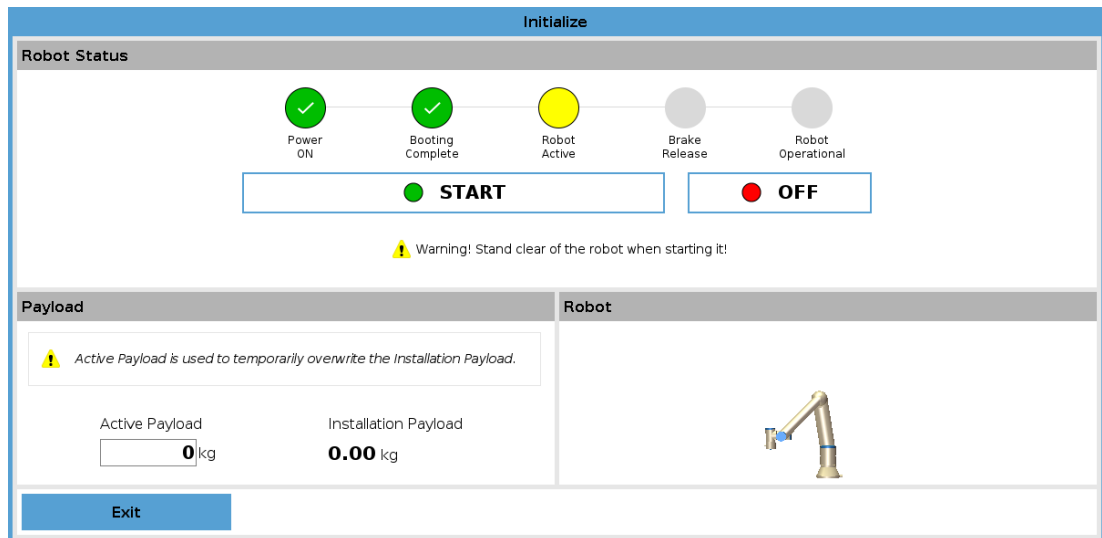

Figure 3.5. Robot status and payload information in the teach pendant.

2. Press and hold *Freedrive*. Status changes to *Backdrive*, as shown in figure 3.6.

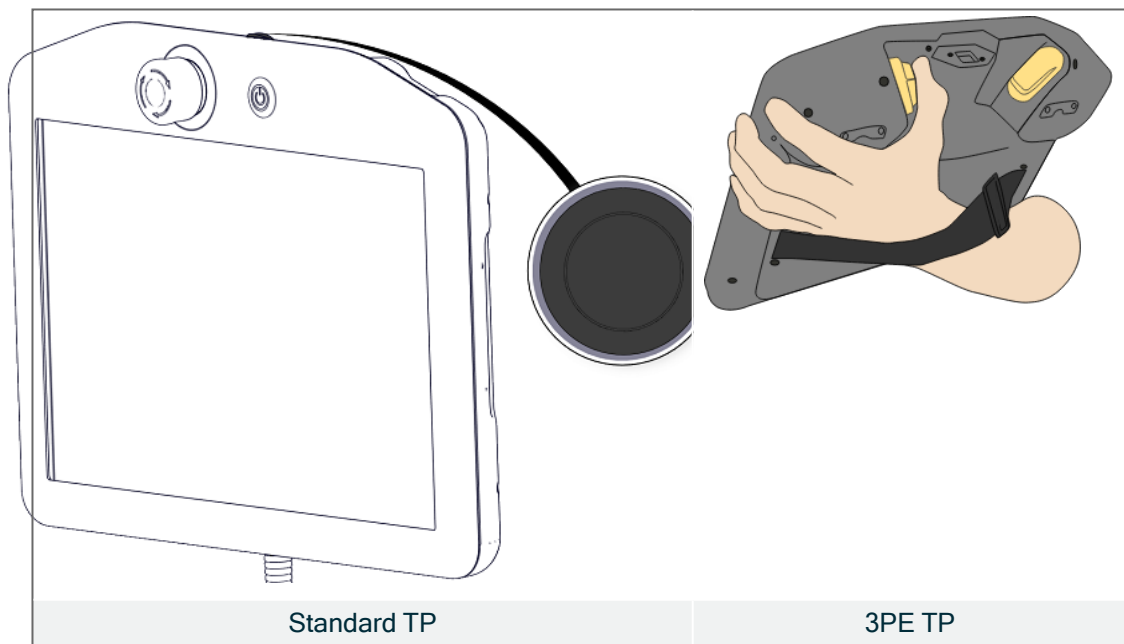

Figure 3.6. Freedriving a standard TP and 3PE TP.



NOTICE

The robot arm is “heavy” to move around in Backdrive, so effort is required to move the joints.

MANDATORY ACTION

You must test Backdrive mode on all joints.

3. Move robot as in Freedrive. Joint brakes are released where needed once the Freedrive button is activated.

Safety settings

Verify the robot safety settings comply with the robot installation risk assessment.

Additional safety inputs and outputs are still functioning

Check which safety inputs and outputs are active and that they can be triggered via PolyScope or external devices.

Backup data

See section [Backup of Data](#)

4.2.3. Visual Inspection: Control Box

1. Disconnect the power cable from the control box.
2. Check the control board terminals are properly inserted. Do not ignore loose wires.
3. Check for any dirt/dust inside the control box. Clean with ESD vacuum cleaner, if needed.



NOTICE

Using compressed air to clean the Control Box can cause damage to the Control Box components.

- Never use compressed air to clean the Control Box.
-

4.2.4. Cleaning

Cleaning the teach pendant touch screen

Use a mild, industrial cleaning agent without thinning agents or any aggressive additives. Do not use an abrasive material to wipe down the screen. Universal Robots does not promote a specific cleaning agent.

Cleaning the control box filters

There is a filter on either side of the control box.

1. Gently remove the outer plastic frame by pulling where the red arrows are, as shown in the images below in figure 3.7. The frame tilts outward.
2. Remove both filters and use low-pressure air to clean them. If necessary, replace filters.

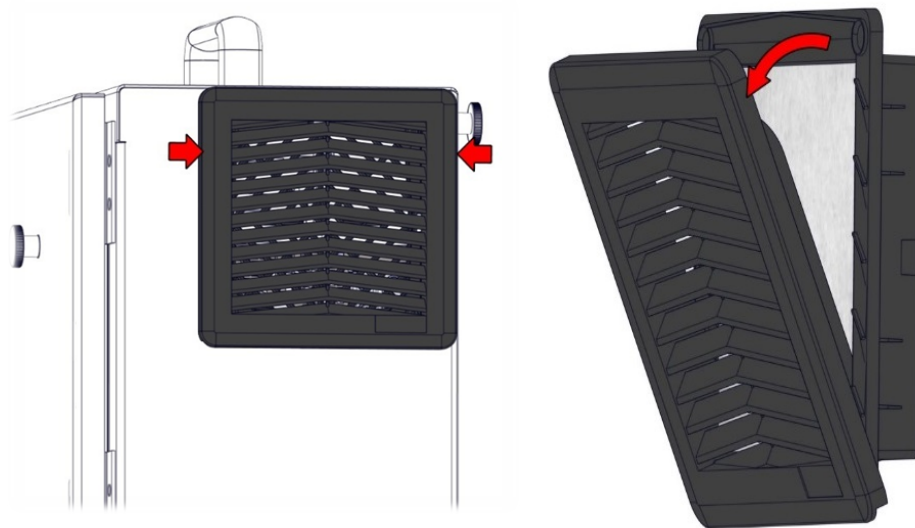

Figure 3.7. Cleaning the control box filters.

5. Service and Replacement of Parts

Installation of a new spare part might require a software update to ensure full functionality. Universal Robots always recommends updating to the latest software release or the current long-term support software version.

See more here: [6.2 Software Updates on page 78](#)

In this chapter, information are provided for services and parts replacements for:

- Pre-use assessment
 - Robot arm
 - Robot cable
 - Control box
-

5.1. Pre-Use Assessment

Tests before first use





The following tests must be conducted before using the robot for the first time or after any modifications are made. Verify all safety inputs and outputs are correctly connected. Test all connected safety inputs and outputs, including devices common to multiple machines or robots, are functioning.

- Test the emergency stop buttons. Check the robot is stopped and the brakes are engaged.
- Test the safeguard input stops the robot's motion. If a safeguard reset is configured, check that it must be activated before motion can resume.
- Test safety boundaries to ensure that Reduced Mode can switch the safety mode and back.
- Test the Operational Mode switches, if connected. See icon on top right corner of user interface to ensure the mode is changing.
- Test the Three-Position Enabling Device (3PE), if connected, to enable motion in manual mode and test that the robot is under reduced speed control.
- Test that the System Emergency Stop Outputs can bring the entire system to a safe state.
- Test that the system connected to Robot Moving Output, Robot Not Stopping Output, Reduced Mode Output, or Not Reduced Mode Output can detect the output changes.

Read Section 9 to learn how to pack down and ship the robot and/or spare parts. [Packing and Shipping of Robot/Spare Parts](#)

5.1.1. Recommended Tools

Figure 4.0.
Robot arm and
control box
components

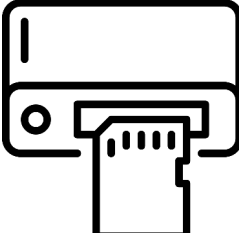
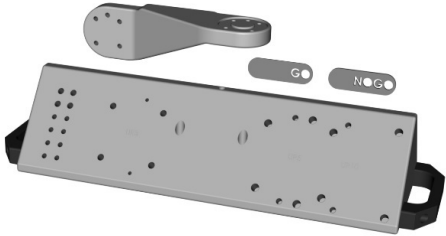
Robot Arm	Control Box	
Service tools - part no.: 200119	Service tools - part no.: 200119	
		
Spirit level or Dual Robot Calibration tooling part no.: 185500	Cabinet key (double-bit key)	SD card reader
		
		

Copyright © 2009-2025 by Universal Robots A/S. All rights reserved.

5.2. Robot Arm

Joint names

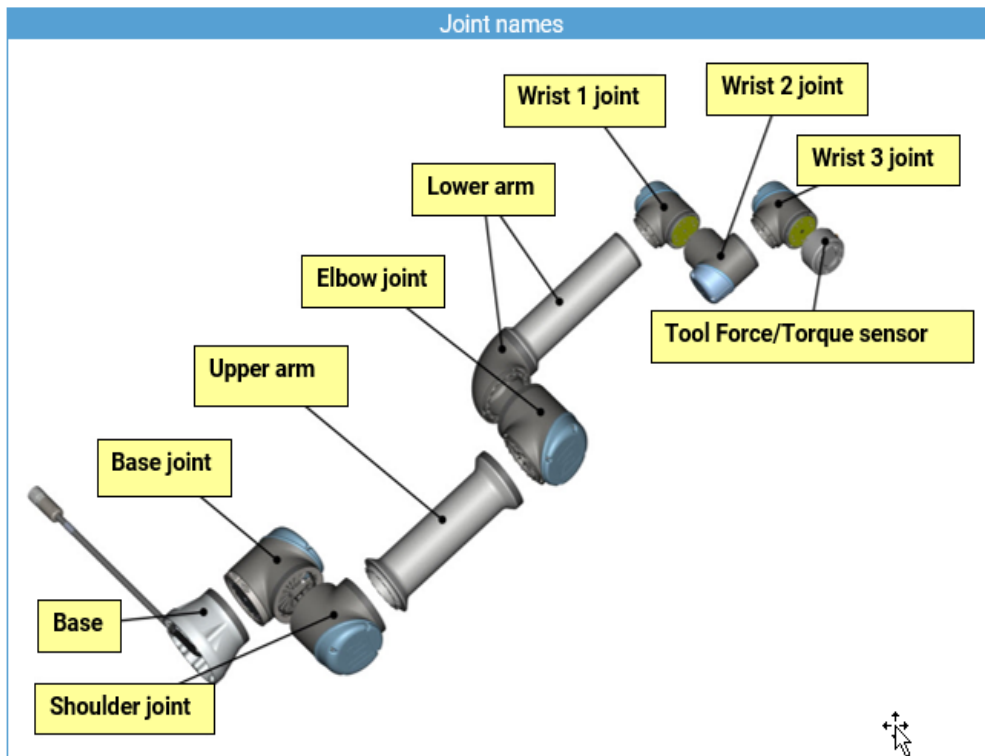

Figure 4.1 Robot arm joint names

Joint sizes

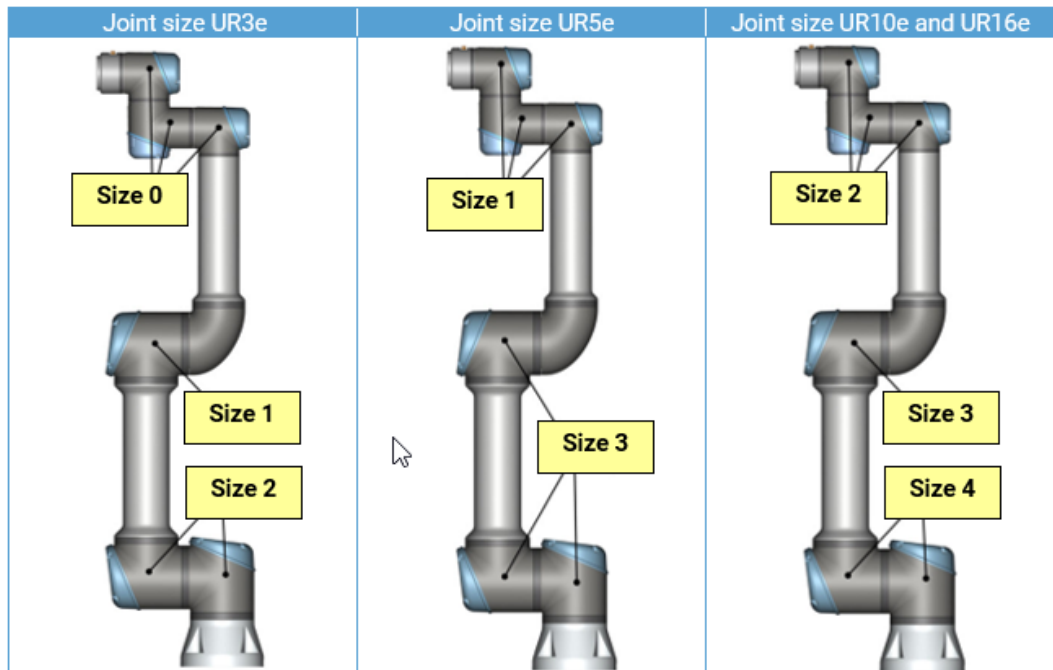

Figure 4.2 UR robot arm joint sizes

5.2.1. Movement Without Drive Power

Forced back-driving

In the unlikely event of an emergency, when the robot power is either impossible or unwanted, you can use forced back-driving or contact your Universal Robots distributor, if this is not possible.

To perform forced back-driving you must push, or pull, the Robot Arm hard to move the joint. Each joint brake has a friction clutch that enables movement during high forced torque.



NOTICE

Moving the Robot Arm manually is intended for urgent emergency and service purposes only.

The brake inside each joint is not designed for manual release.

Attempting to do so without proper training may cause damage to the brake and other joint components. This will make the joint un-usable.

Do not move the joint more than necessary.

Not more than 160 degrees to ensure the robot can find its original physical position.



CAUTION

Attempting to release a joint brake manually may result in injuries personnel or damage to equipment.

5.2.2. General Guidance to Separate Joint from Counterpart

Separating joint from counterpart



WARNING

Before replacing *any* components inside the control box, it is important to completely shut it down first. Follow the first three steps in [Complete Rebooting Sequence](#)



NOTICE

Exercise caution when handling ESD-sensitive parts. See section 2:

Disassemble

1. Before repairing the robot, make sure the necessary tools are available:

- service tools with torque tools
- ESD wristband
- etc.

If you must disassemble the robot arm, you will need:

- new flat rings
- wear rings
- M3 and M4 tap tool ("roll tap" or "forming tap") for threads
- pre-coated screws or Loctite

MANDATORY ACTION

Before continuing, read the complete guide in this manual.

2. Move the robot to an appropriate position for disassembly.
3. Shut down the control box and remove the main power.
4. If necessary, dismantle the entire robot arm from the work cell and place it on a solid surface.
5. Remove screws and the blue lid.

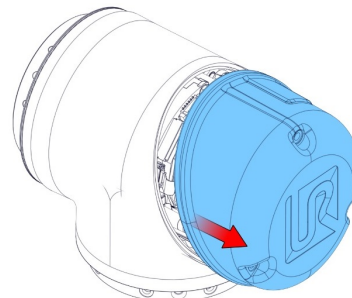
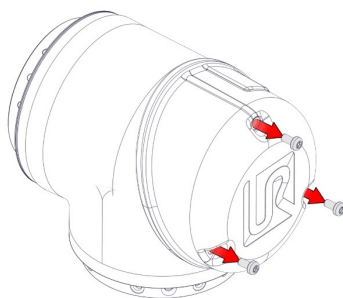

6. Reattach one of the screws on one of the standoffs and mount the alligator clip on your ESD wristband, as shown below.

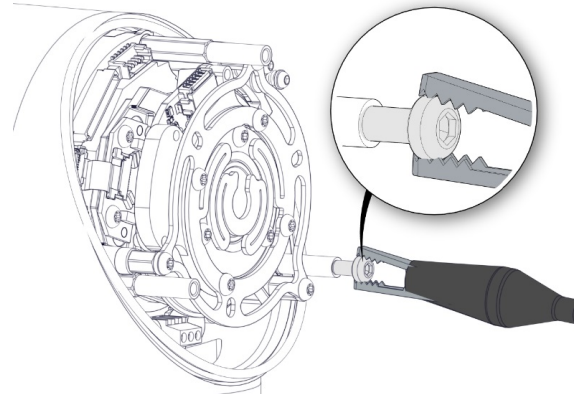
**NOTICE**

Some connectors have a lock that must be engaged before it is pulled out of the PCB.

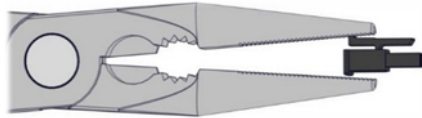

7. **Gently** unplug the cable connectors without bending the PCB.



5.2.3. Joint Connection Types

Joint connections

There are two different ways the joints are assembled.

Screw Connection			Clamp Connection		
					
Head Size	Torque		Head Size	Torque	
Torx T10	0.9Nm for countersunk screws	+0,10Nm	Hex key 4	4.0Nm	+0.50Nm
		-0.10Nm			-0.50Nm
Torx T20	2.0Nm for countersunk screws	+0.30Nm			
		-0.30Nm			

5.2.4. Torque Values

Description



CAUTION

Always refer to the newest version of the service manual when disassembling and assembling any part of the robot arm and the control box.



CAUTION

Always use the specified torque values for the joint connections.



NOTICE

Click the torque tools a minimum of three times before use, to get the correct calibrated torque.

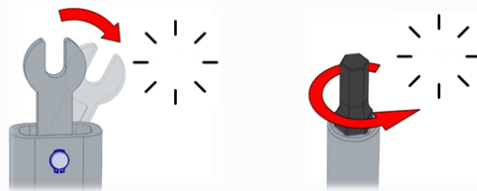

Joint screw tightening torques below match Universal Robots service guidance (service toolkit 200119).

UR3e

From	To	Torque (regular)	Torque (countersunk)	Head size
Base	[J0] Base joint	3.0 Nm	2.0 Nm	Torx TX20
[J0] Base joint	[J1] Shoulder joint	3.0 Nm	2.0 Nm	Torx TX20
[J1] Shoulder joint	Upper arm	3.0 Nm	2.0 Nm	Torx TX20
Upper arm	[J2] Elbow joint	1.3 Nm	0.9 Nm	Torx TX10
[J2] Elbow joint	Elbow counter part	1.3 Nm	0.9 Nm	Torx TX10
Elbow counter part	Lower arm	1.3 Nm	0.9 Nm	Torx TX10
Lower arm	[J3] Wrist 1 joint	1.3 Nm	0.9 Nm	Torx TX10
[J3] Wrist 1 joint	[J4] Wrist 2 joint	1.3 Nm	0.9 Nm	Torx TX10
[J4] Wrist 2 joint	[J5] Wrist 3 joint	1.3 Nm	0.9 Nm	Torx TX10
[J5] Wrist 3 joint	Tool FT sensor	1.3 Nm	0.9 Nm	Torx TX10

**UR5e /
UR7e**

From	To	Torque (regular)	Torque (countersunk)	Head size
Base	[J0] Base joint	4.0 Nm	–	Hex key 4 mm
[J0] Base joint	[J1] Shoulder joint	4.0 Nm	–	Hex key 4 mm
[J1] Shoulder joint	Upper arm	4.0 Nm	–	Hex key 4 mm
Upper arm	[J2] Elbow joint	4.0 Nm	–	Hex key 4 mm
[J2] Elbow joint	Elbow counter part	4.0 Nm	–	Hex key 4 mm
Elbow counter part	Lower arm	4.0 Nm	–	Hex key 4 mm
Lower arm	[J3] Wrist 1 joint	1.3 Nm	0.9 Nm	Torx TX10
[J3] Wrist 1 joint	[J4] Wrist 2 joint	1.3 Nm	0.9 Nm	Torx TX10
[J4] Wrist 2 joint	[J5] Wrist 3 joint	1.3 Nm	0.9 Nm	Torx TX10
[J5] Wrist 3 joint	Tool FT sensor	1.3 Nm	0.9 Nm	Torx TX10

**UR10e /
UR12e /
UR16e**

From	To	Torque (regular)	Torque (countersunk)	Head size
Base	[J0] Base joint	4.0 Nm	–	Hex key 4 mm
[J0] Base joint	[J1] Shoulder joint	4.0 Nm	–	Hex key 4 mm
[J1] Shoulder joint	Upper arm	4.0 Nm	–	Hex key 4 mm
Upper arm	[J2] Elbow joint	4.0 Nm	–	Hex key 4 mm
[J2] Elbow joint	Elbow counter part	4.0 Nm	–	Hex key 4 mm
Elbow counter part	Lower arm	4.0 Nm	–	Hex key 4 mm
Lower arm	[J3] Wrist 1 joint	3.0 Nm	2.0 Nm	Torx TX20
[J3] Wrist 1 joint	[J4] Wrist 2 joint	3.0 Nm	2.0 Nm	Torx TX20
[J4] Wrist 2 joint	[J5] Wrist 3 joint	3.0 Nm	2.0 Nm	Torx TX20
[J5] Wrist 3 joint	Tool FT sensor	3.0 Nm	2.0 Nm	Torx TX20

5.2.5. Power and Communication Connector Types on the Joint

Power plug types

There are two different power plug types and one plug type for communication.
Power Plug Types

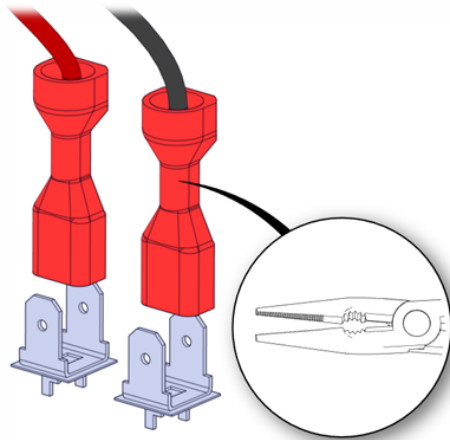

This plug can be removed by *gently* pulling in the *plug*.

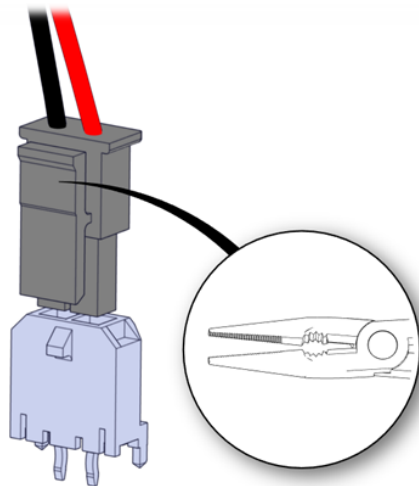

This plug has a lock. Use a flat-nose plier or fingers to unlock and *gently* pull in the *plug*.

Communication Plug Type

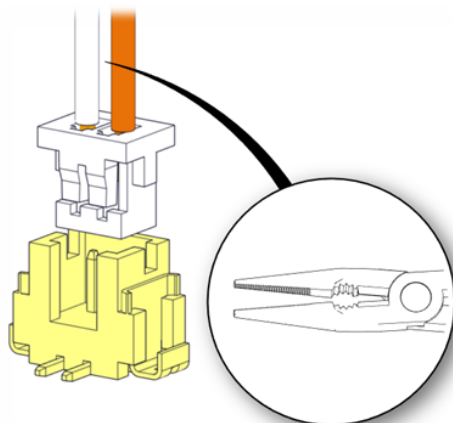

This plug can be removed by **GENTLY** pulling in the *wire*.

5.2.6. Connector Location on Joints

Size 0-1

Size 0

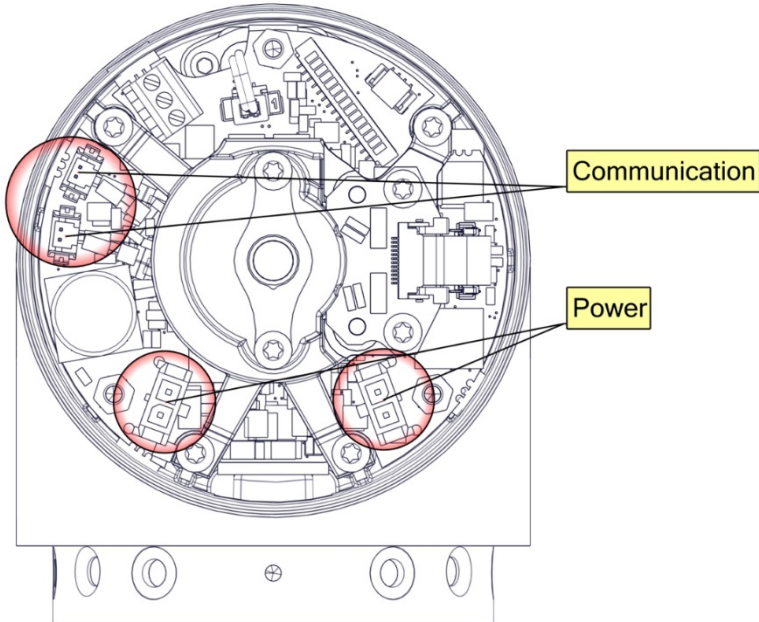

Size 1

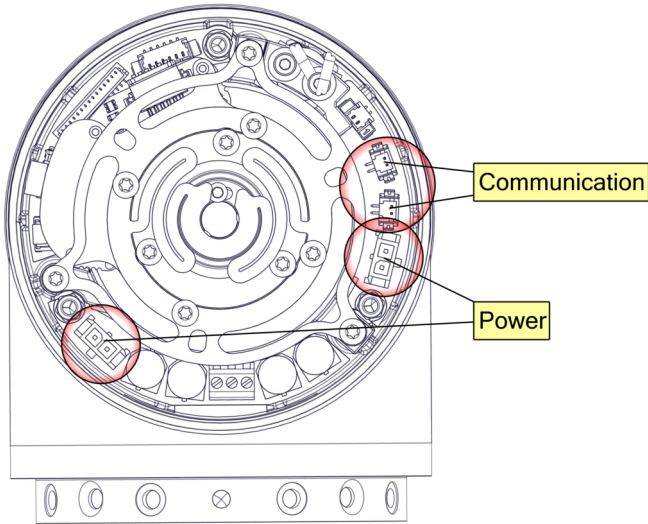

Size 2

Copyright © 2009-2025 by Universal Robots A/S. All rights reserved.

Size 2-3

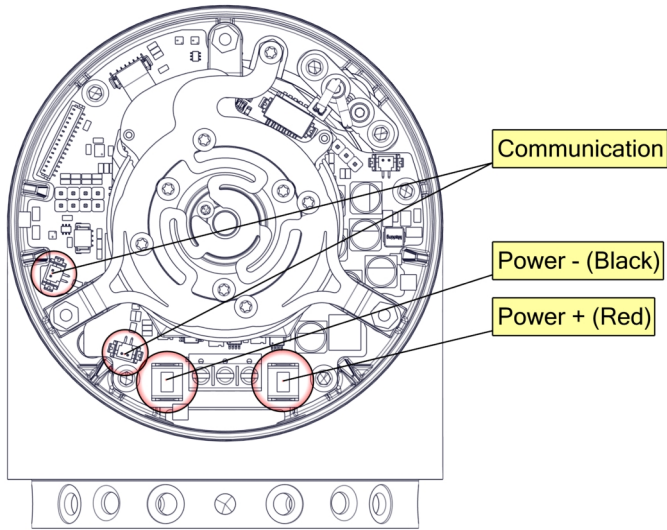

Size 3

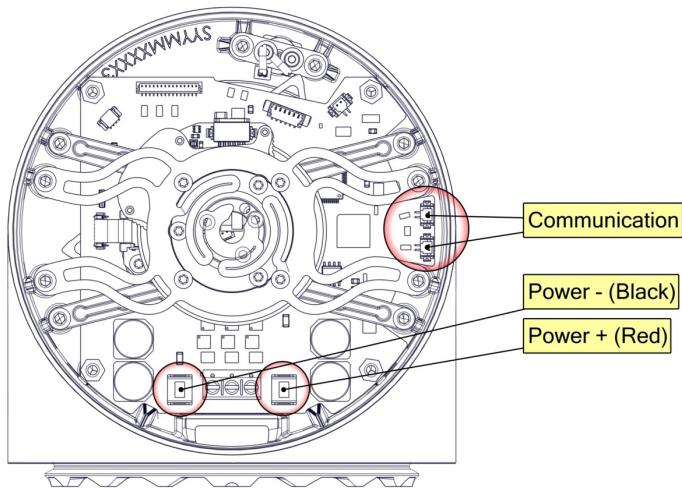

Size 4

Size 4

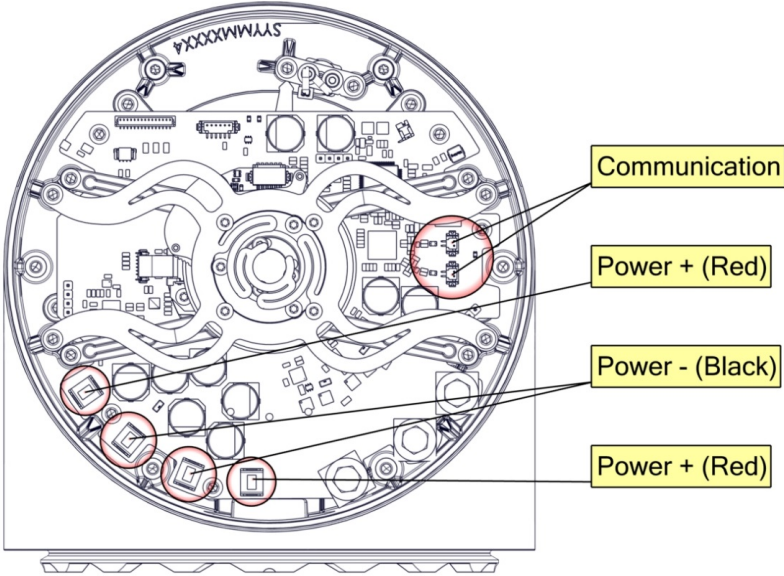



5.2.7. Screw Connection

Screw connection location

The following two sections describe how to disassemble and assemble a joint with a screw-connection.

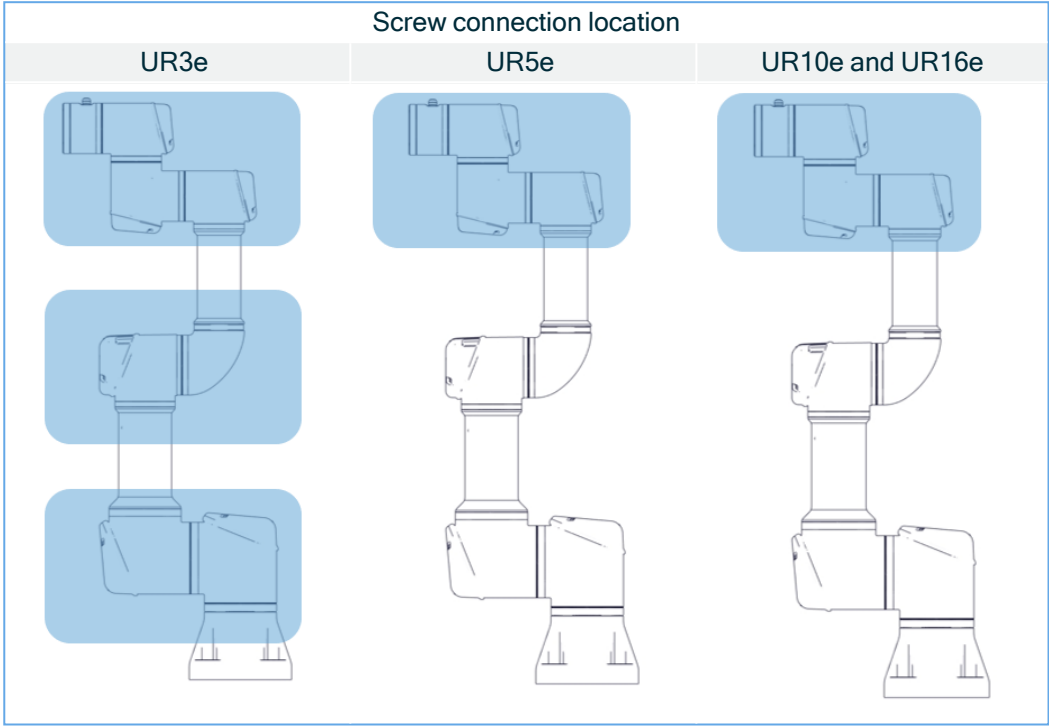

Copyright © 2009-2025 by Universal Robots A/S. All rights reserved.

Disassembling Screw Connection

Screw disassemble

1. Remove the screws in the blue lid, then remove the blue lid as shown in section [General Guidance to Separate Joint from Counterpart](#)
2. **Gently** remove the power and communications wires from the terminals, as shown in section [Power and Communication Connector Types on the Joint and Connector Location on Joints](#).
3. Use a small flat-head screwdriver to push off the flat ring. Then slide the flat ring over the joint.

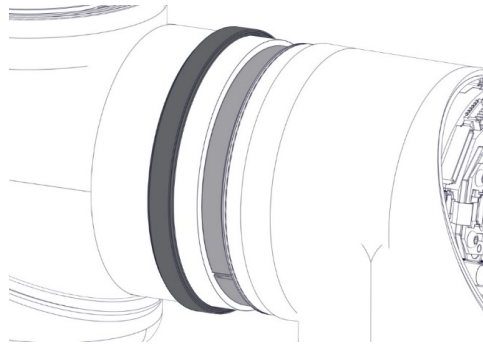
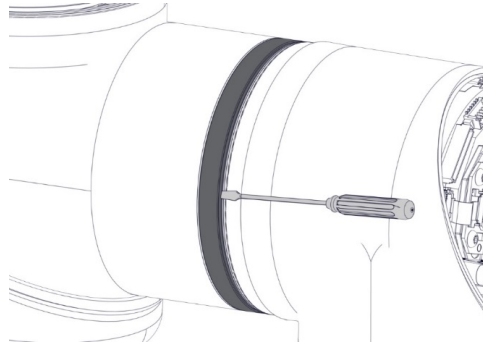

4. Remove Teflon ring.

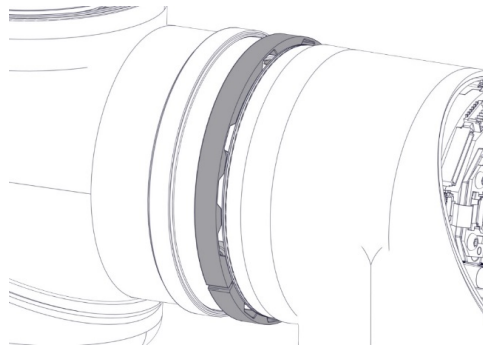

MANDATORY ACTION

The joint can fall off if not supported when removing the screws.

5. First remove the countersunk screws (a), then the remaining screws (b).

Note: Be very careful when removing the screws. Always use a correct-sized and undamaged screwdriver. The screw head slots can easily be stripped.

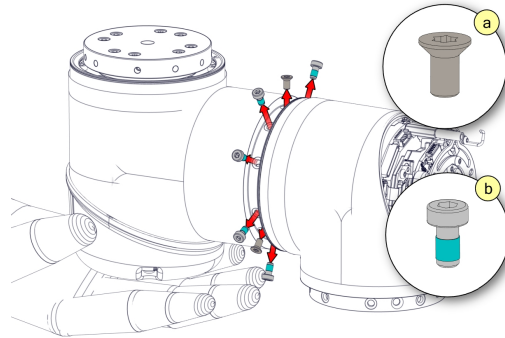

6. The joint is now loose and can be removed. Remember to pull the wires out.

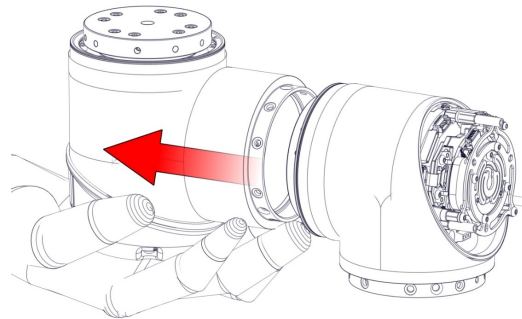



Assemble Screw Connection Joint

Screw assembly

The assembly procedure is done in reverse of the disassembly. However, a few things must be noted before assembly is begun.



NOTICE

- Remove old Loctite residue in the screw holes with a roll tap or forming tap (size 2 M4; the rest M3) for threads before assembling the joint to get the correct torque on the new screws.
- Always use new precoated screws when possible. If you must assemble with old screws, carefully clean the screws and add Loctite 243 to the screws before assembly.
- Always replace the flexible flat black ring with a new one to maintain the IP classification.
- Replace the wear rings if extensive wear or damage is shown.

1. Orient the joints according to the marks (indicated by red arrows in the image below) and gently push the two joints together.
2. Insert and tighten the hex countersunk screws according to the image below. Do not exceed the recommended torque.
Example: 1, 2, 3

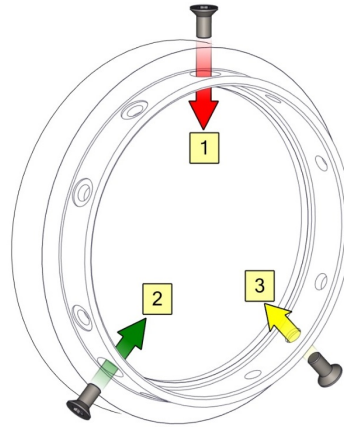

3. Insert and tighten the hex screws according to the image below. Do not exceed the recommended torque.
Example: 1A, 1B, 2A, 2B, etc.

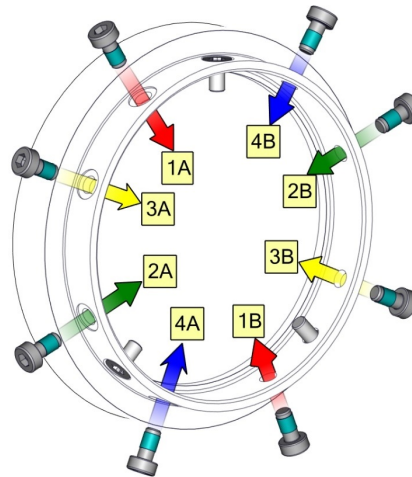



5.2.8. Clamp Connection

Clamp connection location

The following two sections describe how to disassemble and assemble a joint with a clamp connection.

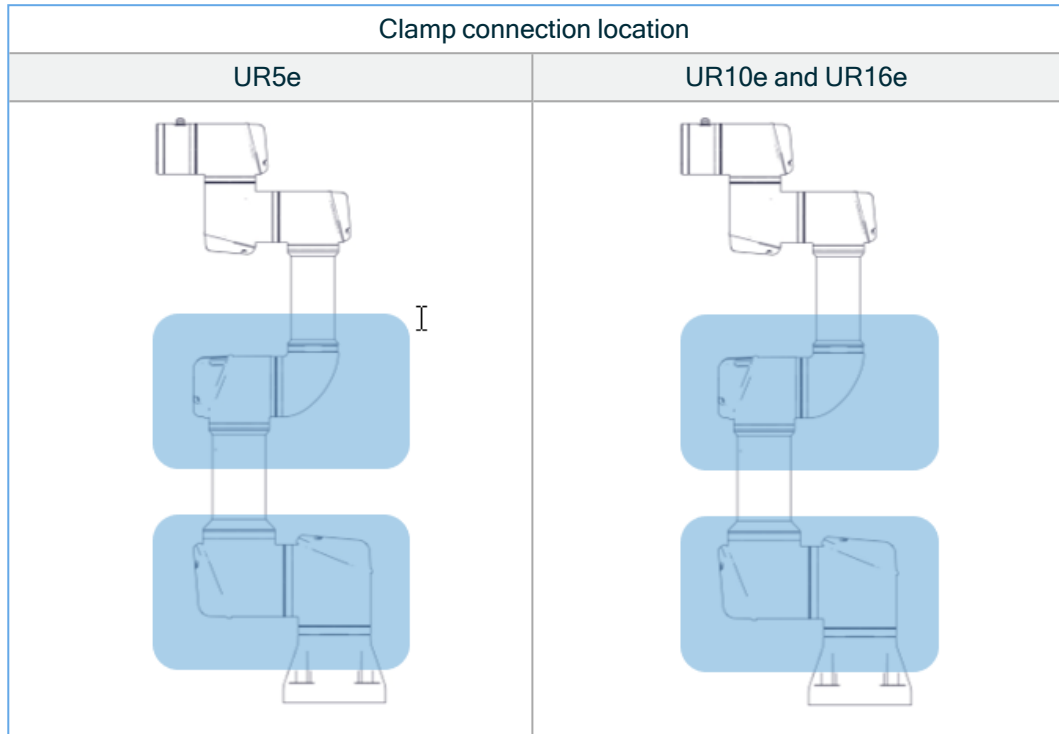

Disassembling Clamp Connection

Clamp disassembly

1. Remove the screws in the blue lid, then remove the blue lid, as shown in section [General Guidance to Separate Joint from Counterpart](#).
2. **Gently** remove the power and communications wires from the terminals, as shown in section [Power and Communication Connector Types on the Joint and Connector Location](#) on joints.
3. Remove the black flat ring. You can use a small flat-head screwdriver.

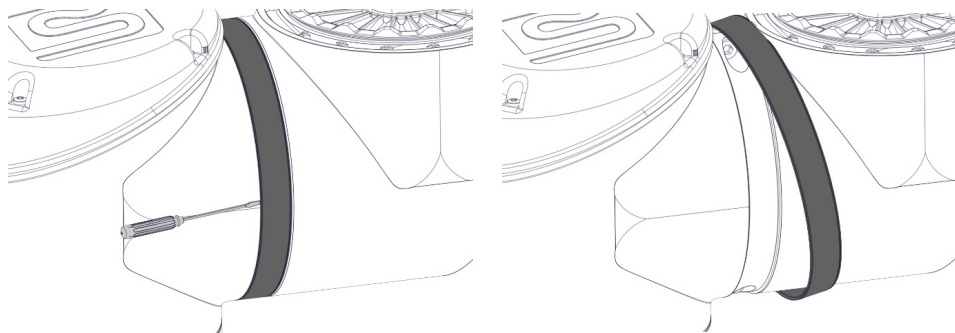

4. Remove the screws and the clamp on one side.

MANDATORY ACTION

The joint can fall off if not supported when removing the clamp.

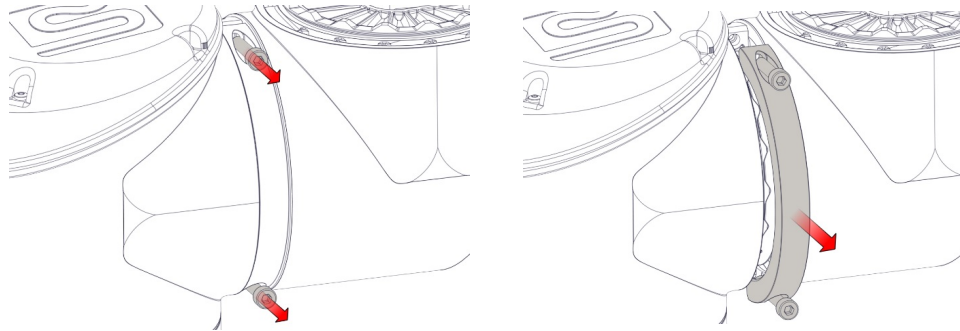

5. Support the joint as you remove the second side of the clamp.

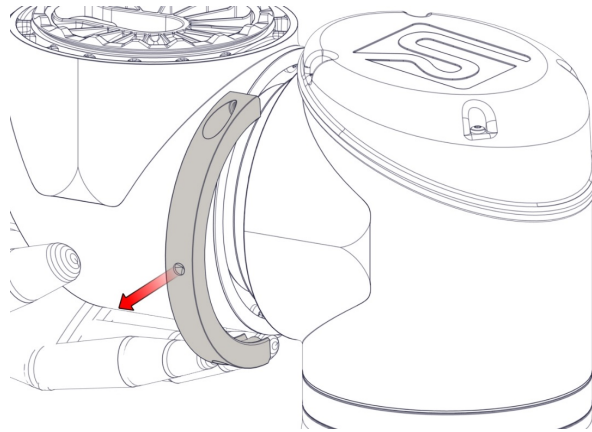

6. The joint is now loose and can be removed. Remember to pull the wires out as well.

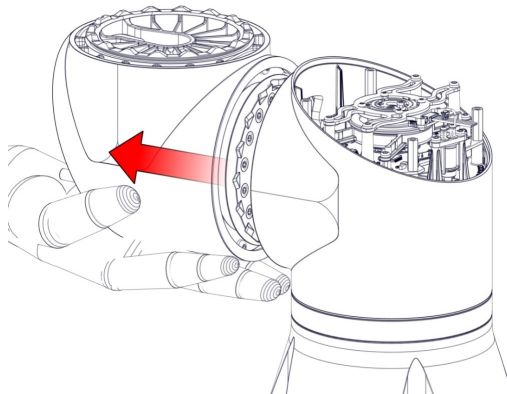

Assembling Clamp Connection

Clamp assembly

The assembly is done in reverse of the disassembly. However, a few things must be noted before assembly is begun.



NOTICE

- Always replace the flexible flat black ring with a new one to maintain the IP classification.
- Replace the foam seal on the clamps, if damaged, to maintain the IP classification.
- Replace the wear rings if extensive wear or damage is shown.
- The dots must be aligned; otherwise, the connection cannot be made.

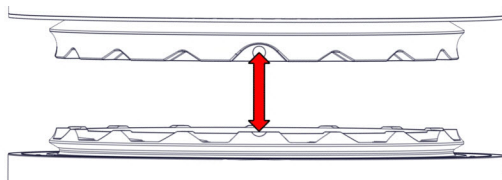
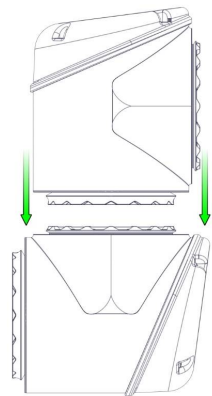
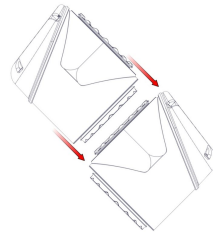
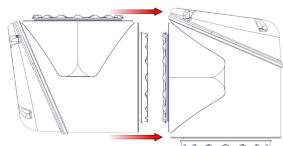

CAUTION

- Joints should be assembled in a vertical position to ensure proper mating between the joints.



CAUTION

- Ensure the screws are inserted in the correct clamp.
- Apply only to earlier version of brackets where one side has a circular marker.

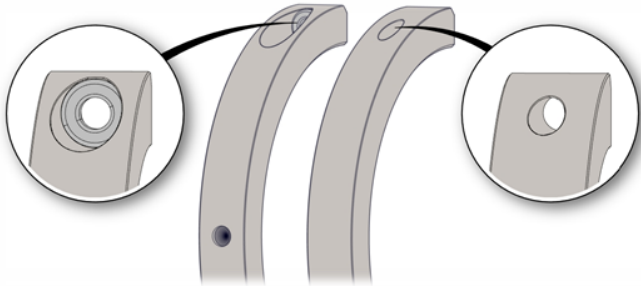

When tightening the clamps, it must be done in steps. Do not exceed recommended torque:

- Step 1: Tighten one side so there is a gap of 1.0mm to 1.5mm.
- Step 2: Tighten the other side completely with 5.0Nm. +/- 0.50 Nm.
- Step 3: Tighten the first side with 5.0Nm. +/- 0.50 Nm.
- Step 4: Ensure same gap at both ends.

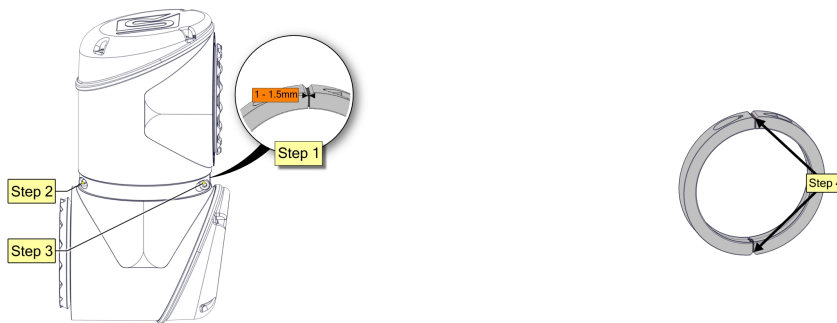

5.2.9. Tool Flange

Description

The tool flange is a screw connection and is disassembled like a joint with this connection.

See section [Screw Connection](#)

Power and communication plug is in the same plug.

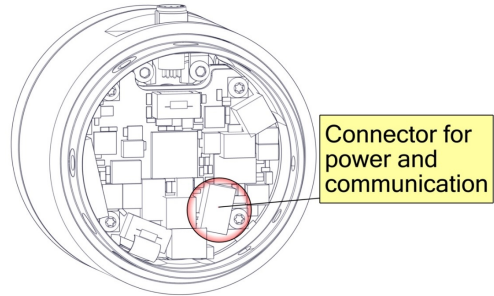

5.2.10. Joint Verification

Verification steps

When a joint is replaced, it needs to be verified by the controller to be assigned the correct ID. The screen below appear automatically when the robot arm is powered on for the first time. Follow the steps.

1. Go to *Initialize* screen and press *On*.

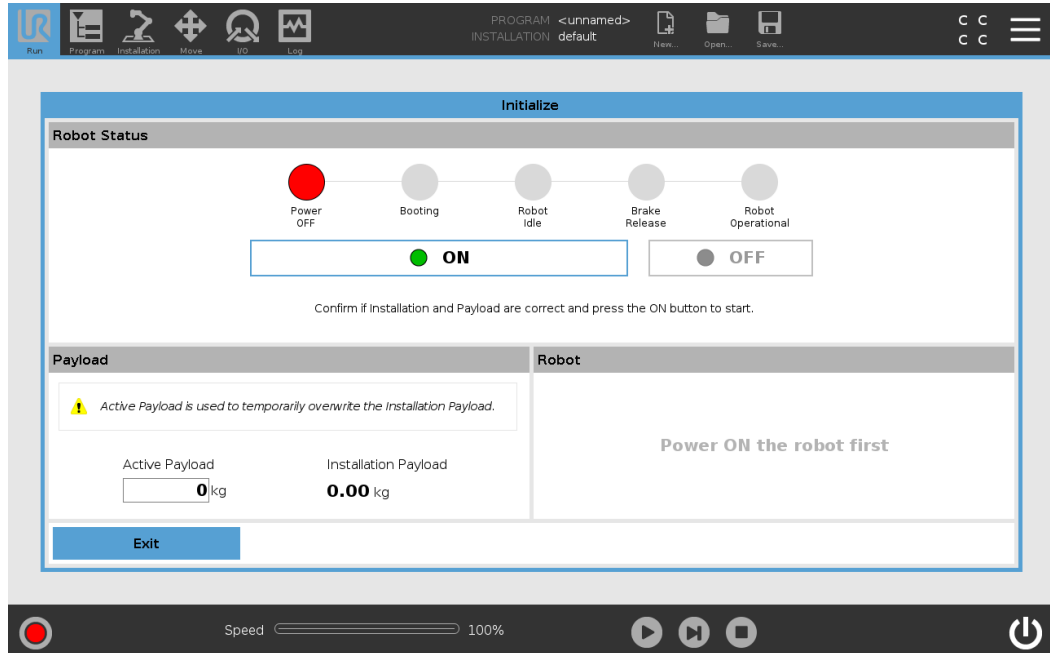

2. A pop-up appears saying that joints need verification. Confirm the pop-up message by pressing *Check*.

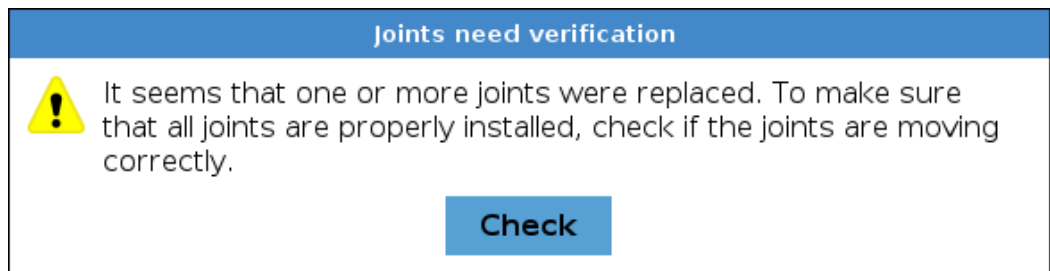

3. Press *Test joints* to start joint verification.

4. Move all joints with the arrows respective to each joint.
 - If joints move as expected, press *Valid*, and a pop-up appears. Follow the pop-up instructions.
 - If joints do not move as expected, i.e., wrong joint moves or incorrect direction), press *Failed* and a pop-up appears. Follow the pop-up instructions.

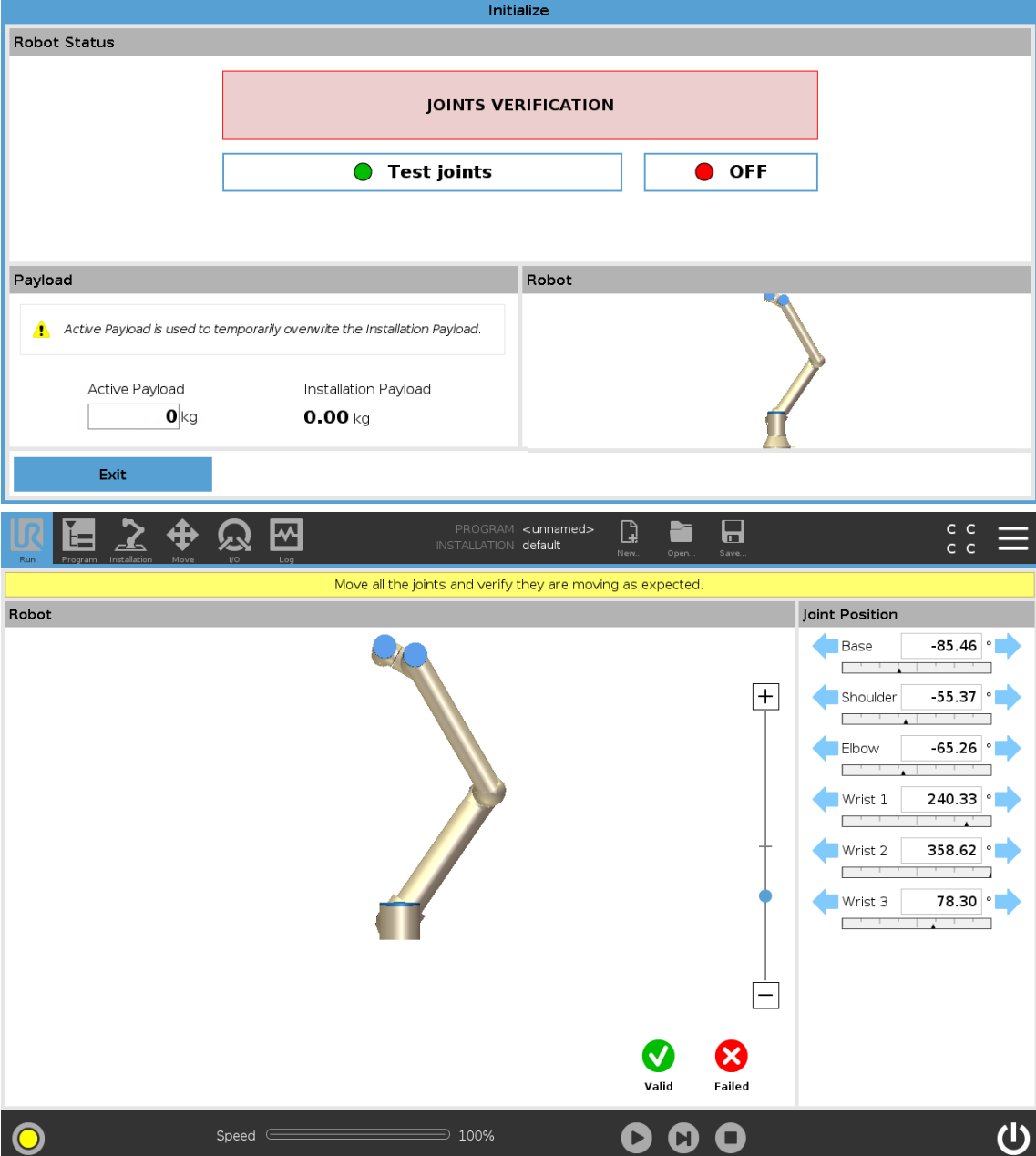

5.2.11. Zeroing of Joints

Steps to zero the joints When a joint has been replaced and verified, it may be necessary to zero the joint so that it is aligned with the rest of the robot arm. There are two ways this can be done.

- Automatically - Dual robot calibration - this is recommended method as it is done via controlled procedure and removes human errors. Please consult Calibration manual for this process.
- Manually - Access Expert mode and use a spirit level, to level the joint.

The following step guides how to zero the joint(s) manually.

1. Power on the robot and ensure the brakes are released.

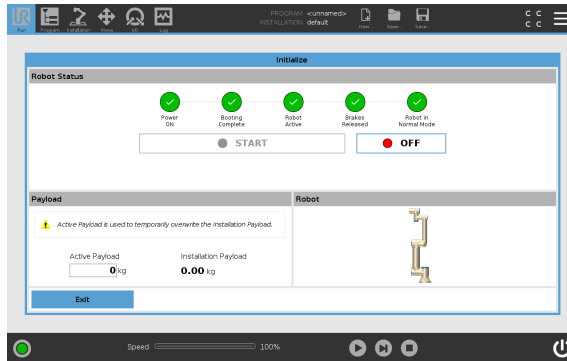

2. Press and hold the UR logo for approximately 5 seconds. The screen will change.

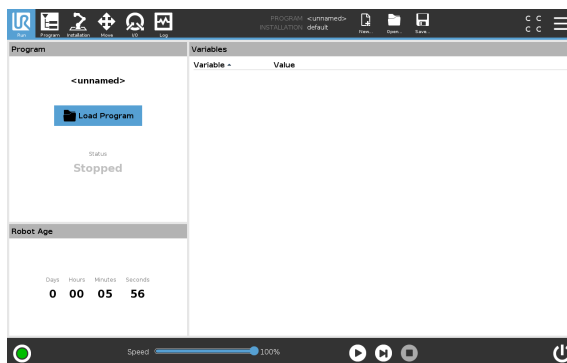

3. Press the gray box and type the password **lightbot** and press OK

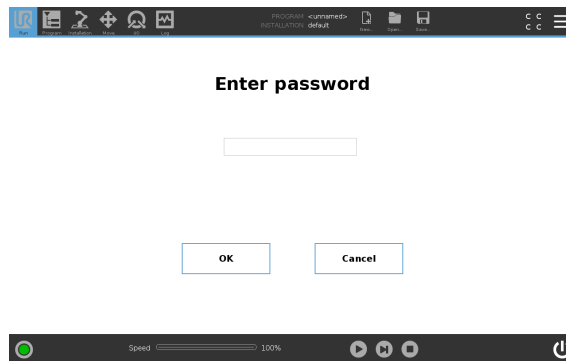

4. Select Joint Zeroing in the menu to the left.

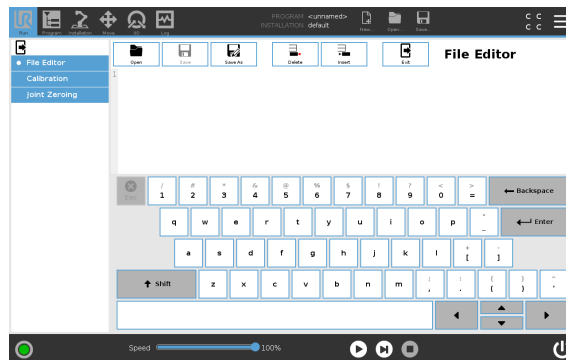

5. Use the arrows in the Joint Position window on the right side of the screen to move each joint to align as shown in the images below. The Speed Slider can be used to reduce the speed of movement.

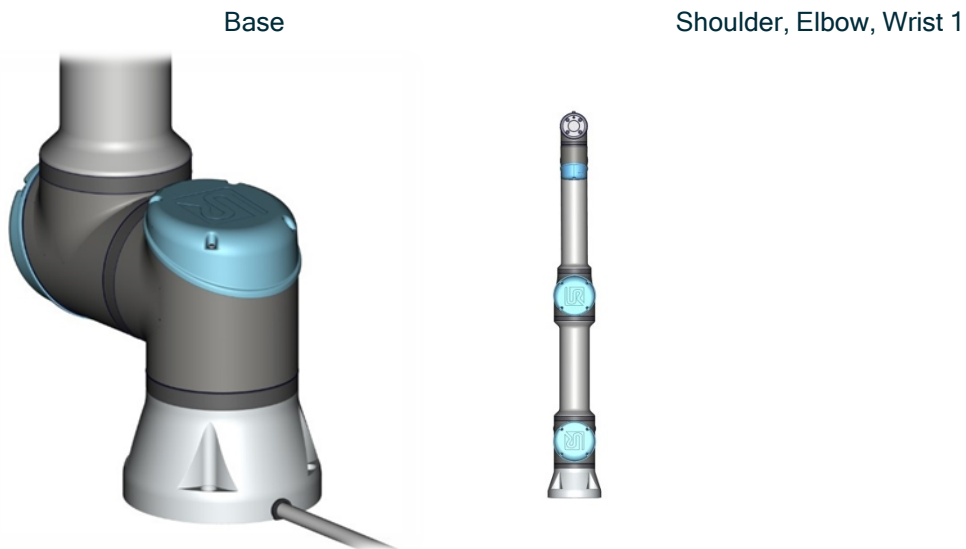

Base zero position is aligned so the Base joint is offset 180 degrees from the cable at the back of the robot base.

Shoulder, Elbow and Wrist 1 zero output flange vertically align (assuming Base is horizontal). Make sure that Base of the robot is horizontal, use spirit level to align joints.

Wrist 2

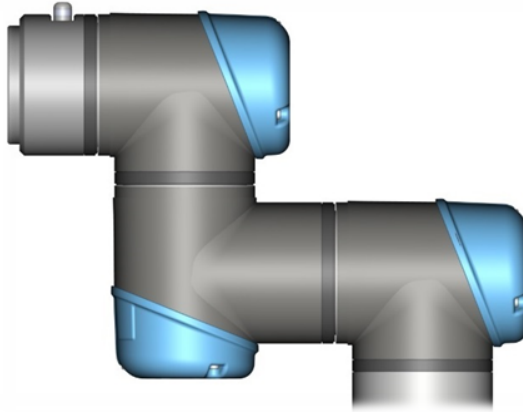

Wrist 3



Wrist 2 zero position is aligned like the Base joint, with tool flange parallel with Wrist 1 output flange.

Wrist 3 zero position is aligned so the tool connector is pointing upward. Mount two bolts in tool holes and use spirit level to align joint.

- In the Joint Zeroing window select the joint you want to zero. When selected the box will change from gray to blue. Press Zero Joints

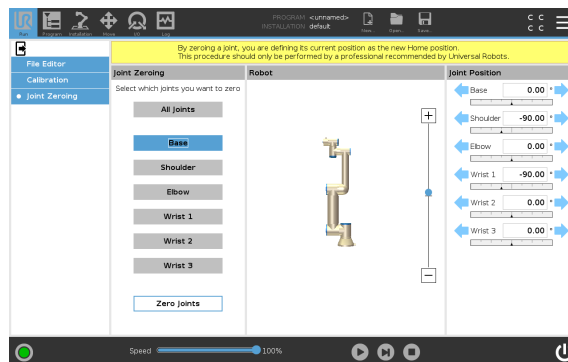

- Confirm you want to zero the joint. The robot will power down after confirmation.

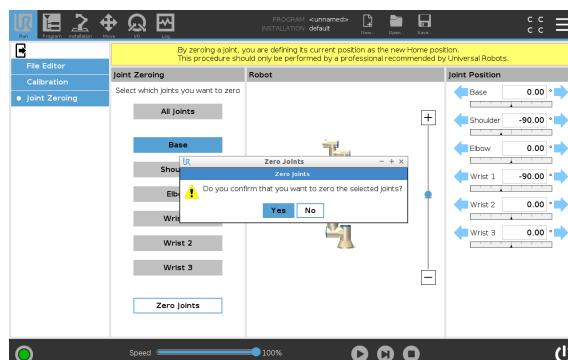

8. A popup shows to confirm that the joint(s) has now been zeroed. Press OK to close the popup and return it to normal.

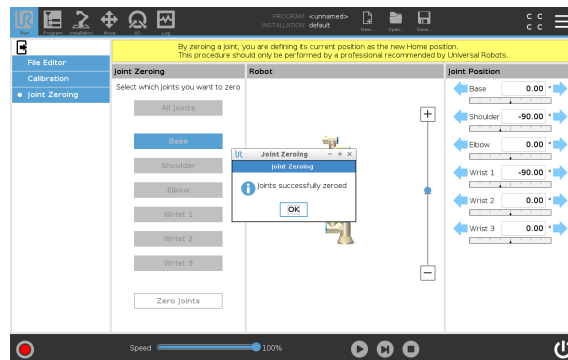

5.2.12. Dual Robot Calibration

Description Dual Robot Calibration calibrates the robot in the full work space. Each new robot is Dual Robot Calibrated as part of final assembly.



NOTICE

If a joint is replaced on a calibrated robot the calibration is no longer valid.

Performing a Dual Robot Calibration after replacement of a joint allows the robot to continue in the production line without modifying waypoints in the robot program.

To perform a Dual Robot Calibration, you need:

- 2 robots (same size and same generation)
- Dual Robot Calibration Tooling Complete (Part no: 185500)

You can download the Calibration Manual from the Universal Robots Support site www.universal-robots.com/support/

5.2.13. Program Correction by Key Waypoints

Description Program Correction by Key Waypoints helps adjusting programs waypoints when a program is moved from an uncalibrated robot to another. The technique can also be used to make programs work after replacements of joints.

Please refer to the Calibration Manual from the Universal Robots Support site www.universal-robots.com/support/ for detailed description on how to use this feature.



NOTICE

Program Correction by Key Waypoints does not currently support the following:

- Other types of waypoints with the exception fixed waypoints.
- Move node with Use Joint Angles selected.

The unsupported program nodes above may need to be corrected manually after the Program Correction by Key Waypoints process is complete.

Important Notice about Size 3 Joint on UR10e

Using size 3 joints manufactured before November 12, 2020, as a replacement for any UR10e size 3 elbow joint (either UR10e with 12,5kg max. payload or UR10e with 10kg max. payload) may damage the housing.

If you hold any spare part joint size 3 in inventory from before 12 November 2020, use it only for replacements of UR5e robots' joints.

Under no circumstances use joints from robots before 12 November 2020 as replacements for UR10e size 3 elbow joint.

Size 3 joints from serial number: 20205001663, date: 12 November 2020, must only be used as spare parts for UR5e robots.

5.3. Robot Cable

5.3.1. Replacing Robot Cable



CAUTION

The maximum robot connection from the robot arm to the Control Box is 12 m. Improper robot connection can result in loss of power to the robot arm.

- Do not extend beyond 12 m.
- Do not make the connection from robot to control box shorter than 6 m.



NOTICE

Connecting the Base Flange Cable directly to any Control Box can result in equipments or property damage.

- Do not connect the Base Flange Cable directly to the Control Box.

Replacement steps

1. On the base of the robot arm, locate the robot connection and twist it to the Open position.
2. Pull the robot connection apart to separate the Robot Cable from the Base Flange Cable.
3. On the Control Box, locate the robot connection cable and twist it to the Open position.
4. Pull the robot connection apart to separate the Robot Cable from the Control Box connector.
5. Connect the new Robot Cable to the Base Flange connector and twist to the Closed position.

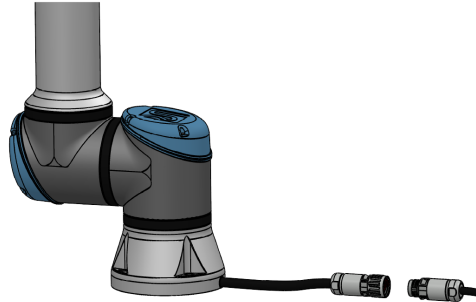

6. Connect the new Robot Cable to the Control Box connector and twist to the Closed position

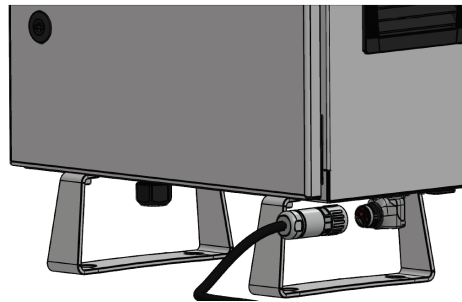

5.4. Control Box

5.4.1. Dismantling the Control Box

Warnings



WARNING

Before replacing ANY components inside the Control Box, you **MUST** do a complete shutdown.

Follow the first 3 steps in section [Complete Rebooting Sequence](#)



NOTICE

Exercise caution when handling ESD sensitive parts.
See section 2.

If possible, lay the Control Box on its back.

Assembling is done in reverse from the steps shown.

Dismantling steps

1. Power off Control Box - follow step 1 to 3 in section [Complete Rebooting Sequence](#)
2. Remove all the I/O Terminals, the Fuse, SD-card and any other I/O etc. that may be connected.

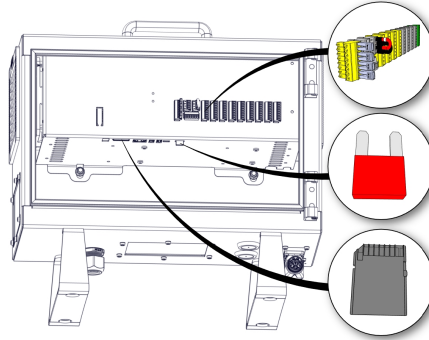

3. Remove the Teach Pendant, see Section [5.4.4 Replacing the Teach Pendant: Standard TP on page 68](#)
4. Lay the Control Box on the backside and remove the four nuts.

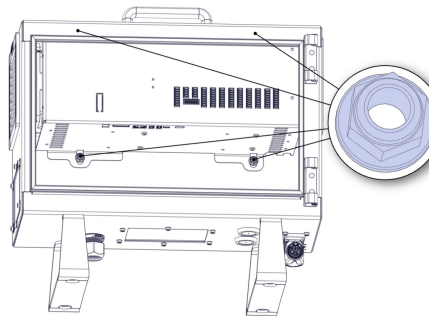

5. Take out the Control Box bracket and place it on the edge of the Control Box as shown below.

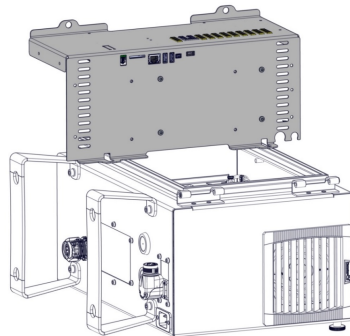

- Remove the wires connecting the Control Box bracket and the Control Box. Take note of the connections or consult the electrical diagram in Section 7. Electrical drawings

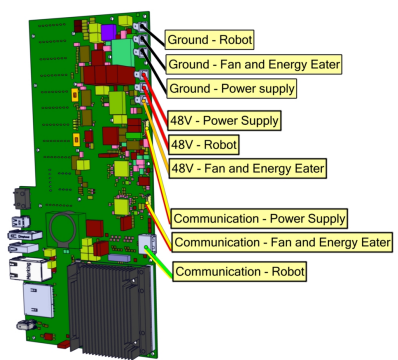
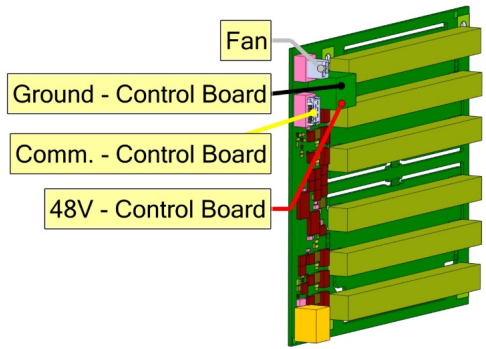

Power Supply

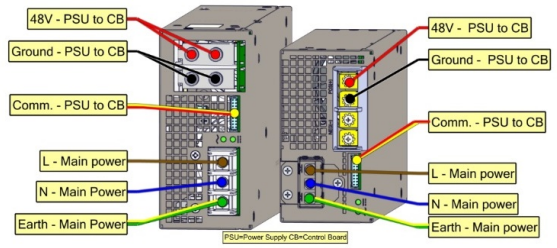

UR5e, UR10e and UR16e

UR3e

Copyright © 2009-2025 by Universal Robots A/S. All rights reserved.

7. Remove the four screws on the bottom of the power supply, then remove the power supply.

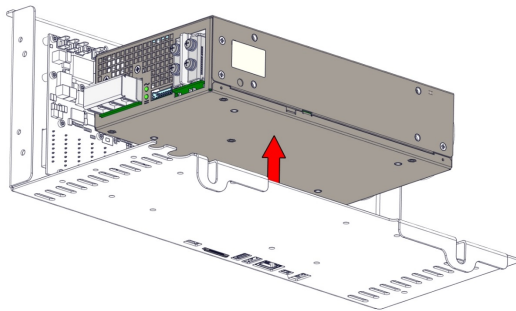
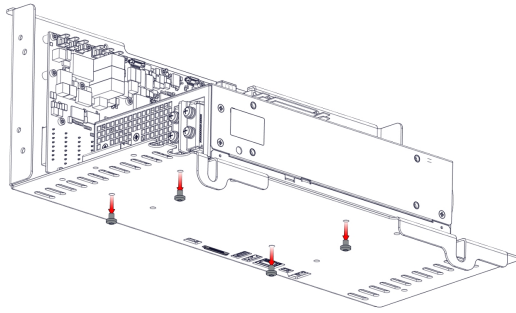

NOTICE

When assembling, the screws must not be tightened with a torque greater than

$\frac{+0.1}{1.0 - 0.1}$ Nm

8. Remove the twenty-two screws and remove the Control Board upward.

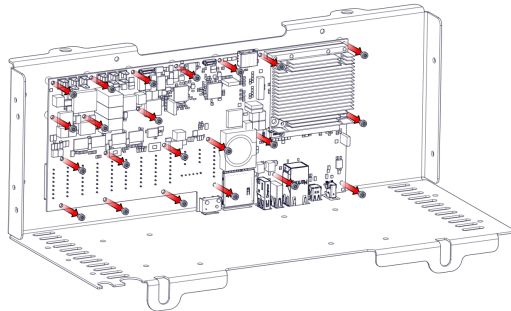

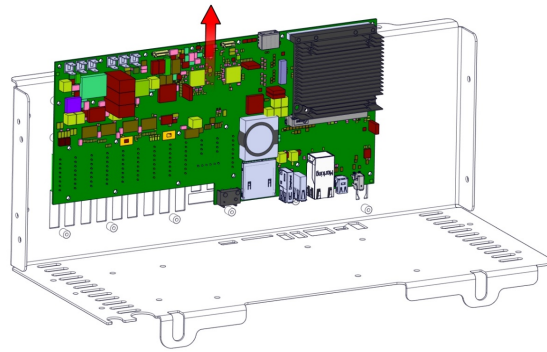

9. Removing the Energy Eater and fan assembly. Remove the four screws.

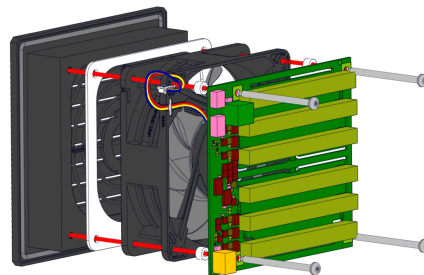
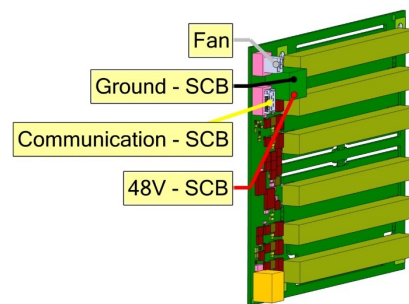
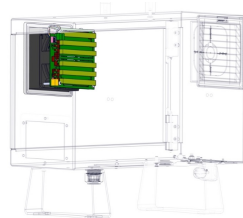

NOTICE

When assembling, remember to place the round spacers behind the Energy Eater board.

5.4.2. Dismantling the OEM AC and DC Control Box

The OEM AC and DC version are special Control Box units made for OEM installation in AC and DC environments.

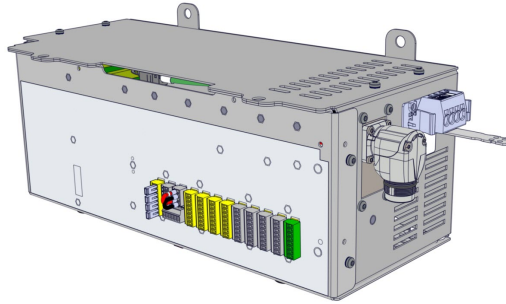

WARNING

Before replacing ANY components inside the Control Box, you MUST do a complete shutdown.

Follow the first 3 steps in section [Complete Rebooting Sequence](#)



NOTICE

Exercise caution when handling ESD sensitive parts.

See section 2.

If possible, lay the Control Box on its back.

Assembling is done in reverse from the steps shown.

OEM DC Control Box Special Precautions

**WARNING**

In case of a battery failure, (for example, due to a short circuit) the current can cause fire or explosion. To avoid injury while performing service:

Wear safety glasses.

Wear fireproof protective gloves.

Do not perform service or maintenance work on the OEM DC Control Box if a circuit breaker, or a power switch and a fuse are not installed.

Ensure that the circuit breaker or the power switch is off and there is no voltage on the power connector before connecting or disconnecting the connector.

**NOTICE**

Since the control box does not have the reverse polarity protection, reversing the DC source polarity causes permanent damage to the control box. Such damage requires the replacement of the DC-DC PSU. To ensure that the polarity of the power source wiring is correct:

Doublecheck the polarity of wires in the power connector using a multimeter. Do not rely on the wire colors unless you have access to the battery terminals and can see where the wires are connected.

Ensure that the wires are installed correctly in the connector terminals.

Ensure that:

Wires are not loose.

Wires are fully inserted in terminals.

Ensure that the control box is grounded properly. For information on grounding, see the OEM Control Box Installation Guide.

Ensure that the wires in the power connector can sustain the short circuit cut-off current of the circuit breaker or fuse. For example, an AWG12 wire is rated up to 34A, so the cut-off current of the protective device must be at least 34A or lower to protect the wire and the system.

Dismantling the OEM AC and DC Control Box

1. Follow step 1 and 2 as described in [Dismantling the Control Box](#)
2. Remove main power connection by pushing in on the two clips and pull backwards.

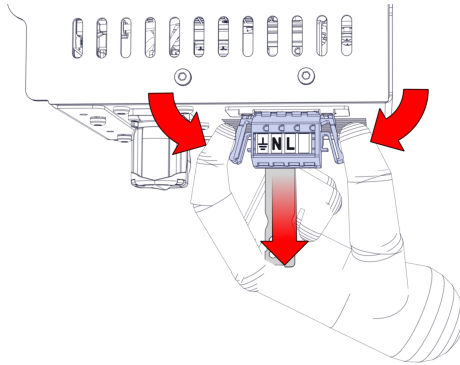

3. Remove robot cable by unscrew the top part clock-wise then pull the plug out.

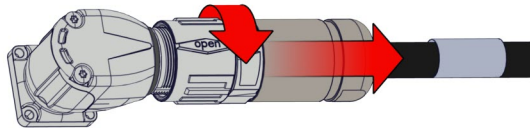

CAUTION

When pulling the robot arm cable connector, be careful not to scrape your hand/fingers on the frame edge.

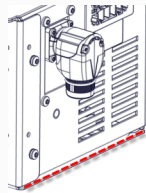

4. Remove the OEM Control Box from its installation and place it on a table or similar.
5. Remove the 4 screws(T20) shown below, remember the washers as well.

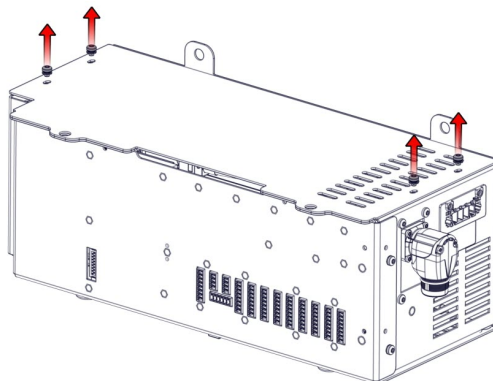

6. Remove the top lid.

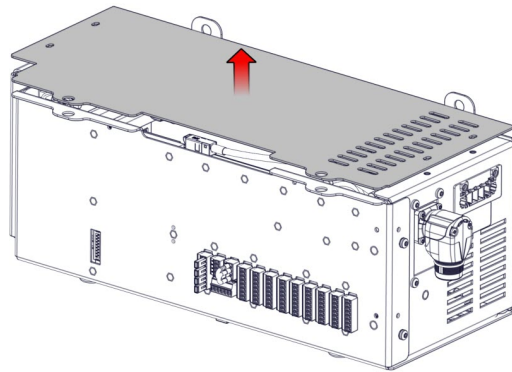

7. Now the power plug on the inside needs to be disconnected from the frame, how to do this correctly is shown in Step 8.

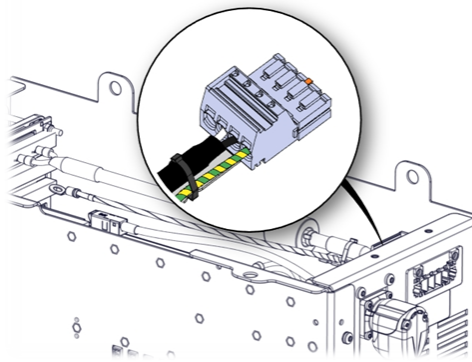

8. For removing the power plug, you will need a small 2mm flathead screwdriver. Pull in the power plug AND tip the two front locks upwards at the same time

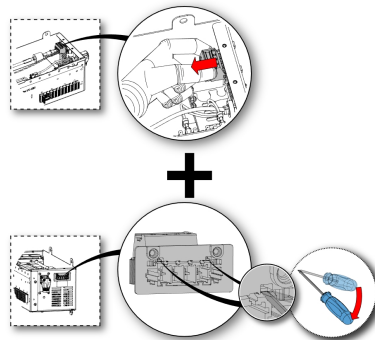

9. Remove all connections to the Control Board.
10. Lay the Control Box on the “back”

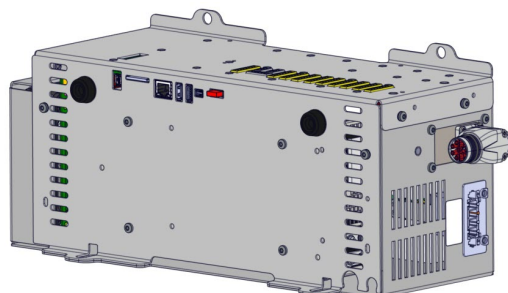

11. Remove the 6 screws(T20) shown below.

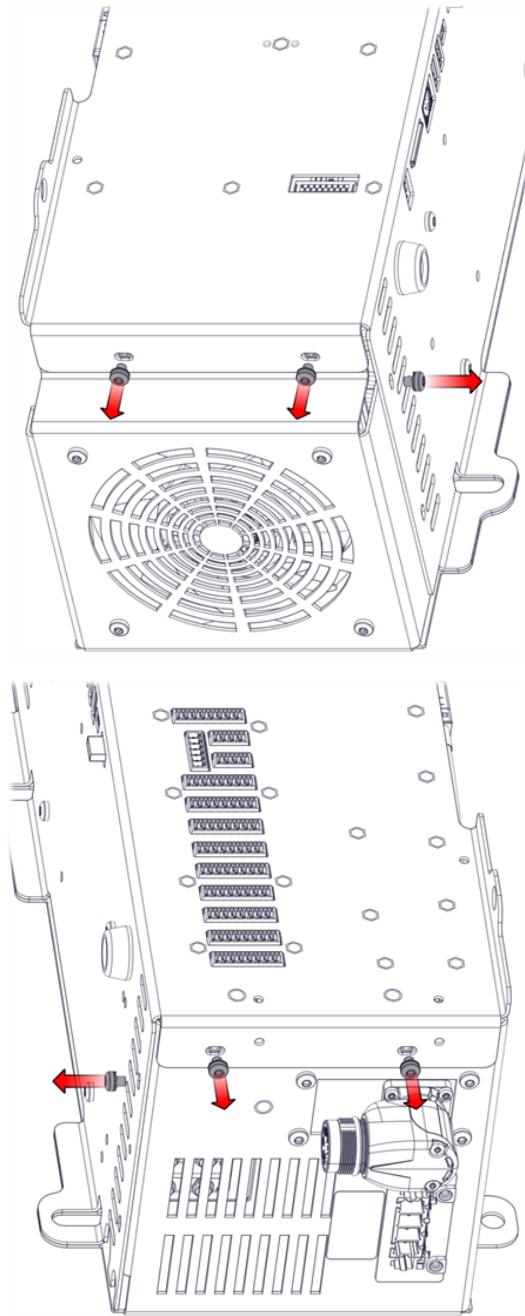

12. Pull out the front part where the power supply and Control Board is attached.

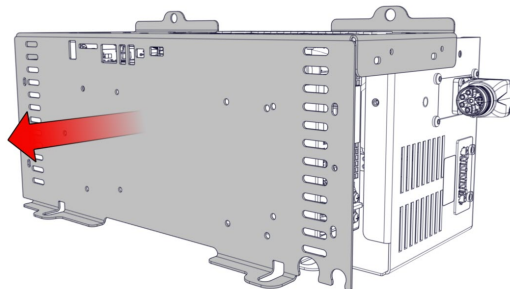

13. There are now two possibilities:
 - Remove Power Supply and/or Control Board
 - See step 7 and 8 in section [Dismantling the Control Box](#)
NOTE: Remember to cable tie the energy eater cable to the power cable when assembly the unit.
 - Remove Energy Eater and/or Fan
See next step.
14. Remove the 4 nuts(7mm) on the Energy eater side and pull the individually part off the screws(T20).

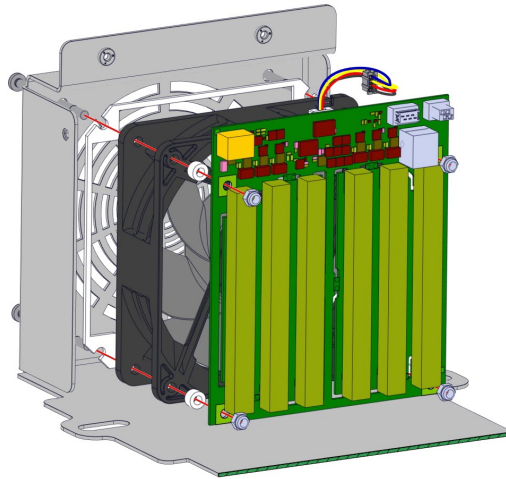

5.4.3. Torque Values

Torque Values and Notes for Control Box

Below are the torque values used in the Control Box.

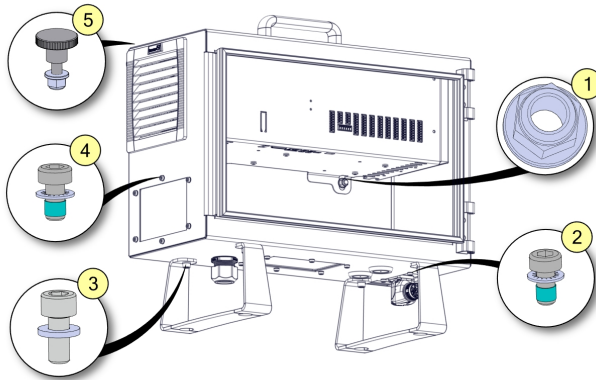

NO.	DESCRIPTION	Tool size	Torque
1	Nut for internal CB bracket	10mm	2.25Nm
2	Robot connector screw	Torx T20	1.5Nm
3	Screw for feet bracket	Hex key 5	4.0Nm
4	Screw and washer for cover plate	Torx T20	1.5Nm
5	Control Box and Teach pendant mounting nut	10mm	2.25Nm

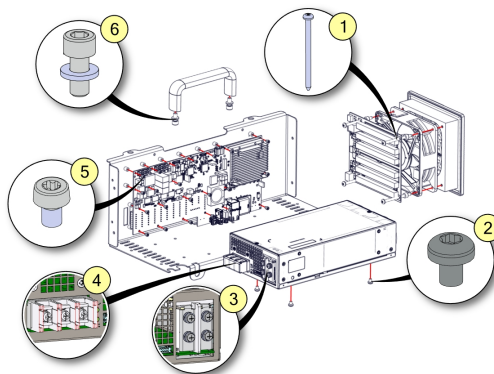

NO.	DESCRIPTION	Tool size	Torque
1	Screw for fan and energy eater assembly	Torx T20	0.6Nm
2	Screw for mounting power supply	Torx T20	1.0Nm
3	Internal power terminal screws	PZ2	1.2Nm
4	External power terminal screws	PZ2	1.2Nm
5	Control Board mounting screws	Torx T10	0.6Nm
6	Bolt for Control Box handle	Hex key 5	4.0Nm

Torque Values and Notes for OEM AC and DC Control Box

Below are the torque values used in the OEM AC and DC Control Box.



NOTICE

The washer, when present, need to have the spikes facing downwards.

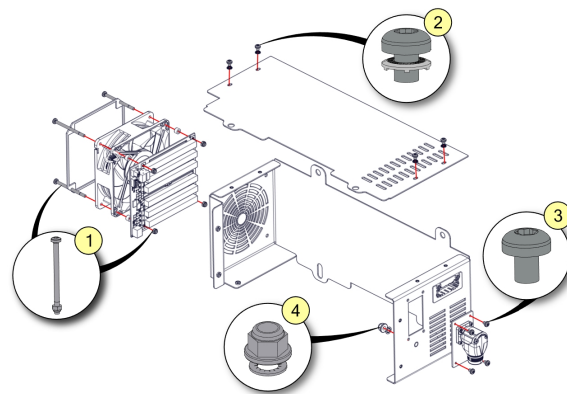
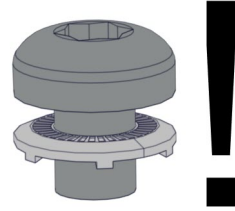

NO.	DESCRIPTION	Tool size	Torque
1	Bolt and nut for fan and energy eater	Torx T20/7mm	0.6Nm
2	Panel screw and washer	Torx T20	1.6Nm
3	Robot connector screw	Torx T20	1.6Nm
4	Shield connecting bold and washer	10mm	2.25Nm

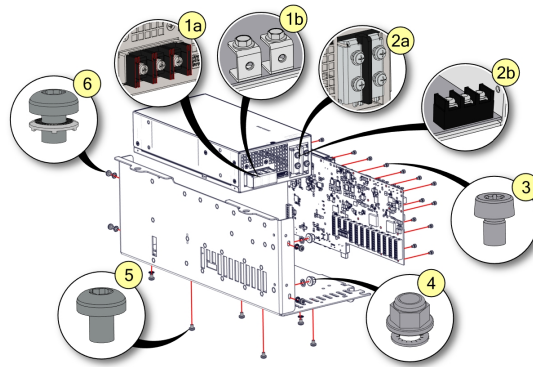

NO.	DESCRIPTION	Tool size	Torque
1a	AC external power terminal screws	PZ2	1.2Nm
1b	DC external power terminal bolts	8mm	1.6Nm
2a	AC internal power terminal screws	PZ2	1.2Nm
2b	DC internal power terminal screws	PZ2	1.6Nm
3	Control Board mounting screws	Torx T10	0.6Nm
4	Bolt and nut for fan and energy eater	10mm	2.25Nm
5	Power supply mounting screw	Torx T20	1.0Nm
6	Panel screw and washer	Torx T20	1.6Nm

5.4.4. Replacing the Teach Pendant: Standard TP

Removing & Replacing

This section describes how to remove and replace a Standard Teach Pendant. For information on how to replace a Standard Teach Pendant with a 3PE Teach Pendant, see [5.4.5 Replacing the Teach Pendant: 3PE TP on page 70](#).



WARNING

When the Teach Pendant is replaced, test the E-stop button function.



NOTICE

Replacing the Teach Pendant can result in the system reporting a fault on start-up.

- Always select the correct configuration for the type of Teach Pendant.

To remove

1. Power down the control box and disconnect the mains cable from the power source.
2. If mounted, remove the ferrite core with snap lock from the teach pendant cable by cutting the cable ties of key.

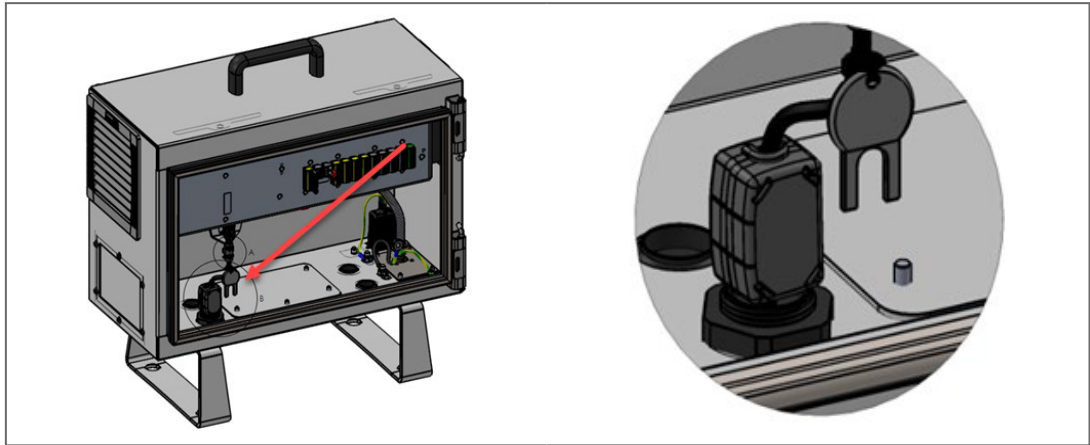

3. Insert the key into the ferrite core with snap lock to unlock it and remove it.



4. Remove and discard the two cable ties used for mounting the Teach Pendant cables.
5. Press in the clips on both sides of the Teach Pendant plug, as illustrated below, and pull down to disconnect from the Teach Pendant port.
6. Fully open/loosen the plastic grommet at the bottom of the control box and remove the Teach Pendant plug and cable.
7. Gently remove the Teach Pendant cable and Teach Pendant.

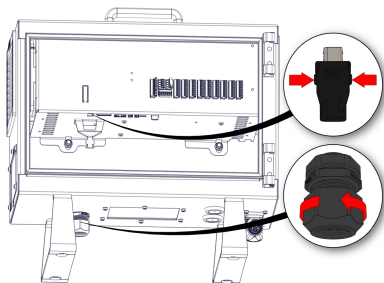

To replace

1. Place the Teach Pendant plug and cable in through the bottom of the Control Box and fully close/tighten the plastic grommet.
2. Push the Teach Pendant plug into the Teach Pendant port to connect.
3. Use two new cable ties to mount the Teach Pendant cables.

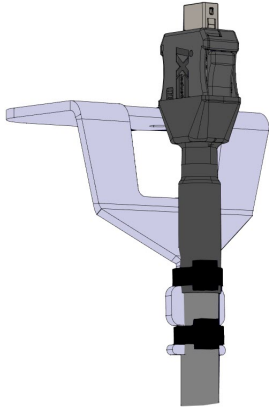

1. If mounted previously, mount the ferrite core with snap lock again. If the ferrite core was not mounted from production, a new one does not need to be mounted.
2. Connect the main power cable to the power source and power on the Control Box.

5.4.5. Replacing the Teach Pendant: 3PE TP

Description

This section describes how to replace a Standard Teach Pendant with a 3PE Teach Pendant. For information on how to remove and replace a Standard Teach Pendant, see [5.4.4 Replacing the Teach Pendant: Standard TP on page 68](#).

**WARNING**

When the Teach Pendant is replaced, test the function of the 3PE buttons.

**NOTICE**

Replacing the Teach Pendant can result in the system reporting a fault on start-up.

- Always select the correct configuration for the type of Teach Pendant.

To remove

1. Power down the control box and disconnect the main power cable from the power source.
2. If mounted, remove the ferrite core with snap lock from the teach pendant cable by cutting the cable ties of key.

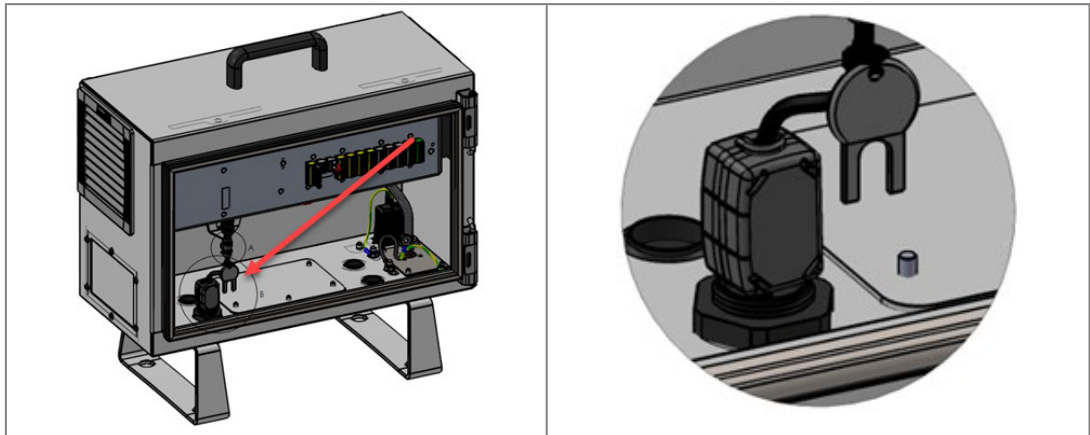

3. Insert the key into the ferrite core with snap lock to unlock it and remove it.



4. Remove and discard the two cable ties used for mounting the Teach Pendant cables.
5. Press in the clips on both sides of the Teach Pendant plug, as illustrated, and pull down to disconnect from the Teach Pendant port.
6. Fully open/loosen the plastic grommet at the bottom of the Control Box and remove the Teach Pendant plug and cable.
7. Gently remove the Teach Pendant cable and Teach Pendant.

To replace

1. Place the 3PE Teach Pendant plug and cable in through the bottom of the control box and fully close/tighten the plastic grommet.
2. Push the 3PE Teach Pendant plug into the Teach Pendant port to connect.
3. Use two new cable ties to mount the 3PE Teach Pendant cables.
4. Connect the main power cable to the power source and power on the Control Box.

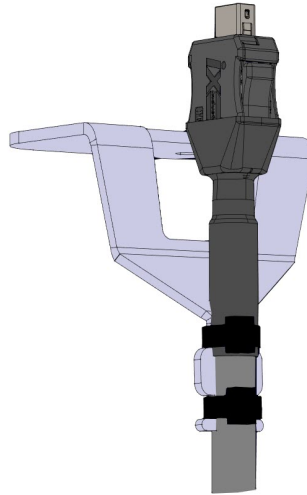

5.4.6. Replacement of Teach Pendant Cable

Use the teach pendant cable repair kit

The teach pendant cable can be replaced with a teach pendant cable repair kit.
Note: Read thoroughly the disclaimer in the kit before installing.

**13-step
process**

1. Turn the teach pendant around and place it screen down on a soft surface. Be careful not to damage the E-stop button.
2. Remove the eighteen (18) bolts connecting the front frame to the back plate using a T8 torx screwdriver.

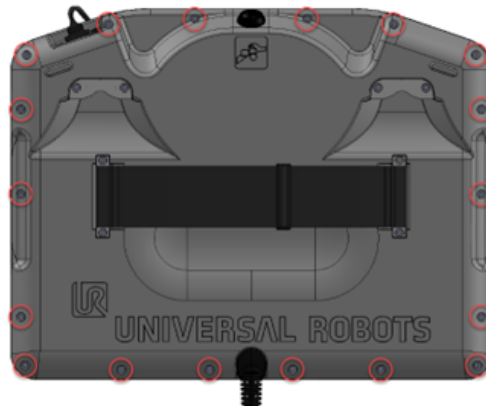

3. Pull the front frame and back plate apart. This will, in some cases, require some force, but note that there is a cable connecting the two parts. Be careful that this cable or connectors do not get damaged.



4. On the front frame, cut the cable tie and unplug the cable that connects the front frame and back plate.

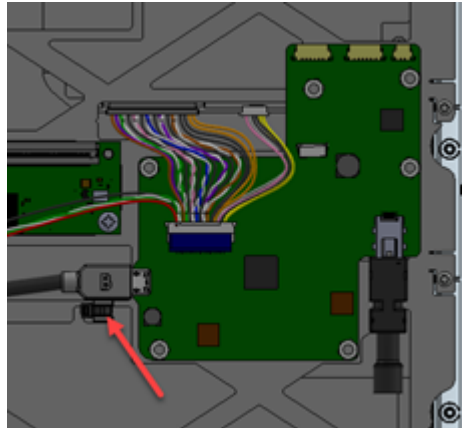

5. Unplug the teach pendant cable.

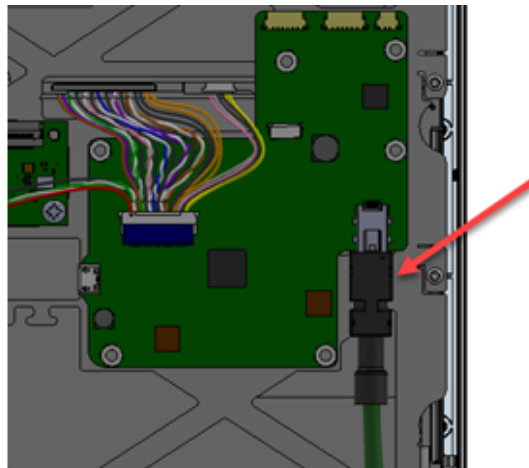

6. On the back plate, remove the four bolts on the teach pendant cable bracket using a T8 torx screwdriver, and remove the bracket.

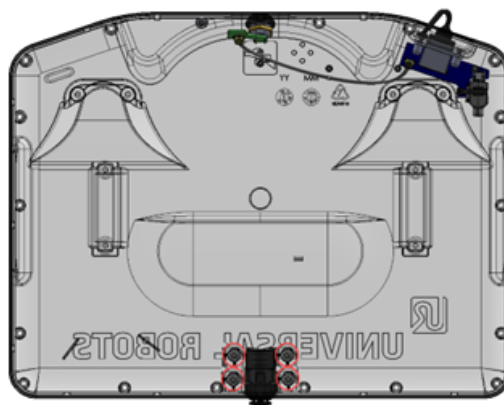

7. Teach pendant cable can now be removed.

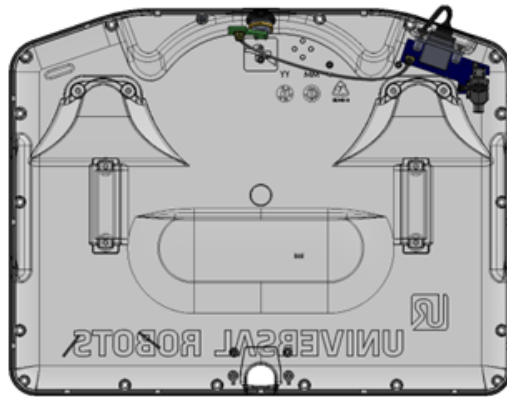

8. Find the new teach pendant cable from the kit. Pull it through the hole of the back plate. Make sure that the rubber cable collar is mounted correctly at the hole.

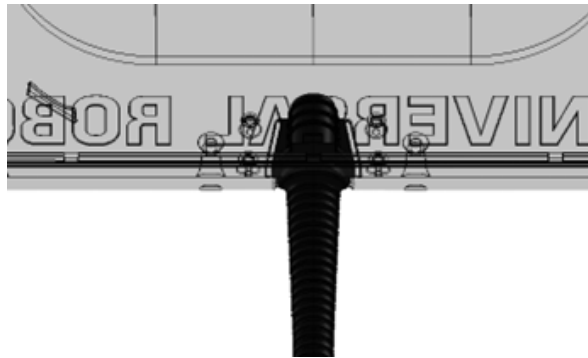

9. Mount the teach pendant cable bracket again and mount the four bolts with 0.3 Nm using a T8 torx screwdriver.

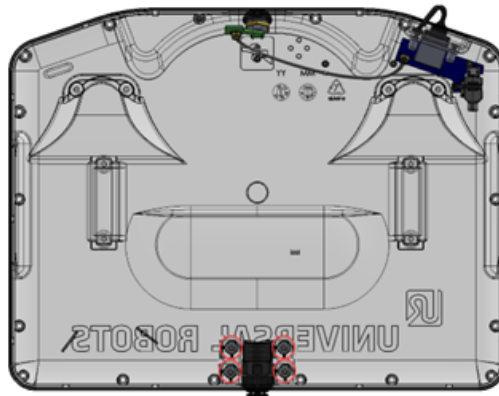

10. On the front frame, reconnect the teach pendant cable on the PCB connector.

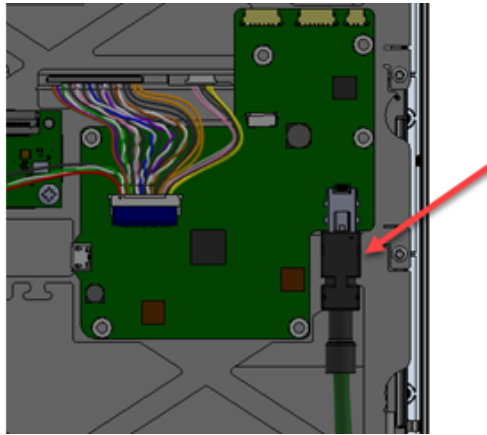

11. Connect the cable between the front frame and back plate on the other PCB and mount the new cable tie from the kit.

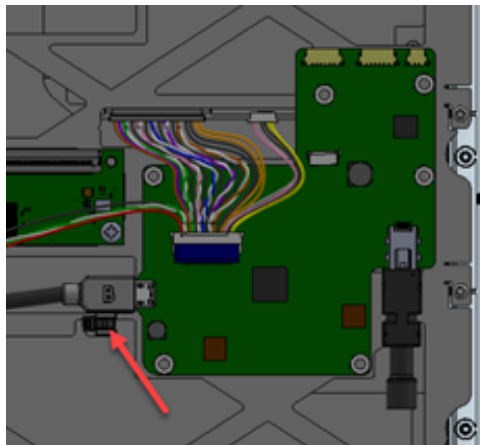

12. Connect the front frame and back plate again.

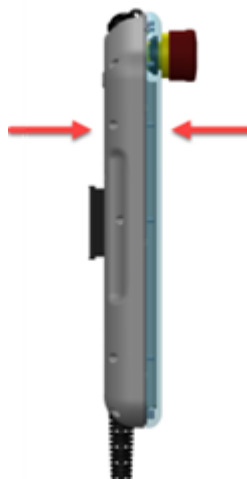

13. Mount the eighteen (18) bolts connecting the front frame to the back plate with 0.3 Nm, using a T8 torx screwdriver.

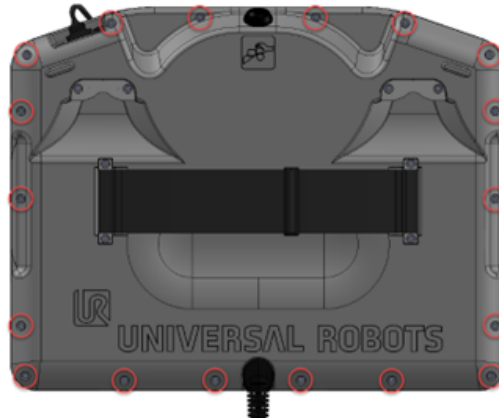

6. Software

Polyscope

Under 5.13, Universal Robots does not recommend or support downgrading of Polyscope software. Downgrading can, in some cases, break hardware compatibility or corrupt program functionality. When in doubt, reach out to Universal Robots.

6.1. Long Term Support

Software support

Since PolyScope software release 5.12, UR has introduced a long-term support strategy to ensure hardware compatibility with requiring updating to latest software version. The long-term supported software version does not introduce new features but will ensure hardware compatibility due to product changes. Please note that it is the major software release that will be long-term supported. The minor releases are continuously updated (e.g. 5.12.x is long-term supported, the minor releases, stated with x, will be subject for changes) See which PolyScope version is currently long-term supported on Universal Robot's website: <https://www.universal-robots.com/support/>

6.2. Software Updates

About Polyscope

Universal Robots software is called PolyScope.



CAUTION

Read these instructions and the instructions on our support website (www.universal-robots.com/support) completely prior to updating your software. Universal Robots assumes no responsibility for failed updates caused by improper operation.

Control Box power **MUST NOT** be turned off during the software update process. Failure to meet this demand is likely to cause loss of data and malfunction.

Keeping the robot software up to date is required to ensure safe operation. Also, the latest software provides more features and a better performance.

Read the Release Notes of the software you install. Release Notes hold notes about the software changes which in some cases are relevant for safe operation of the robot.

Updating the software may cause changes to functionality. Robot motions might change or be subjected to different restrictions.

In case of questions or concerns related to your application please contact your supplier for advice and assistance.

Not all combinations of updates are possible. These are the rules to observe:

- If running **PolyScope 5.5.0 and above**:
Update directly to PolyScope 5.8.0 or any later version.
- If running **PolyScope 5.4.3 and below**:
Updates must be done incrementally in steps of one minor version.
E.g. PolyScope 5.2.1 à 5.3.1 à 5.4.3 à 5.5.1.
When PolyScope 5.5.0 is reached, software can be updated directly to the latest version.

Therefore, when updating your robot software care must be taken to select a proper update path. Several update steps will be necessary until reaching a version of 5.5.0. Downgrading software is not supported. In PolyScope 5.5.0 backup and restore functionality is added and this is the recommended way to go back to any prior version installed. We strongly recommend that you precede any update cycle with a backup to counter the situation of a failing update. Please contact your supplier if updating causes any trouble.

6.2.1. Update Procedure

15-step process

1. On your robot, go to About and check your current software version.

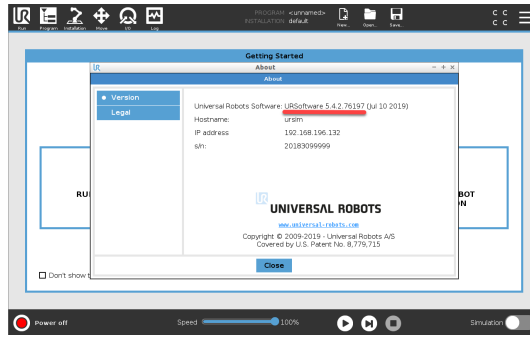

2. Download to your computer the software versions needed to be installed, you can download from Universal Robot's website (www.universal-robots.com/support).
 - If your SW is below 5.5 (E.g.: 5.3), you will need to incrementally update until you reach 5.5 (E.g.: 5.3 to 5.4, then 5.4 to 5.5), after updating to software 5.5 you can download the most up to date software and go straight from 5.5 to this last update (E.g.: 5.5 to 5.8).
 - If your SW is equal or above 5.5, just download the most updated software version file and install it straight from your current software version (E.g: 5.5 to 5.8).
3. Download the software version(s) needed to update your software and save file(s) in the root of a USB stick on your computer.
4. Insert the USB stick into the USB slot in the controller box.
5. On teach pendant screen, press the right top corner icon  to access the settings menu.

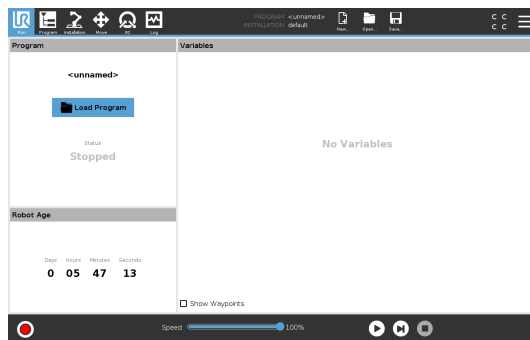

6. Press Settings to access the settings menu.

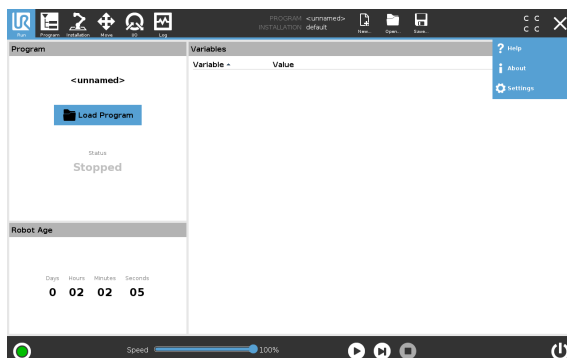

7. On the left side menu, select System.

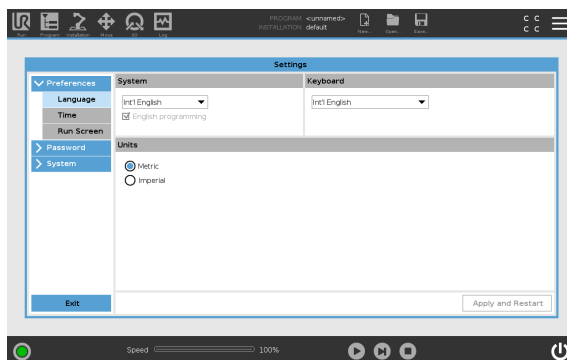

8. Press Update, then Search to locate software update on USB stick.

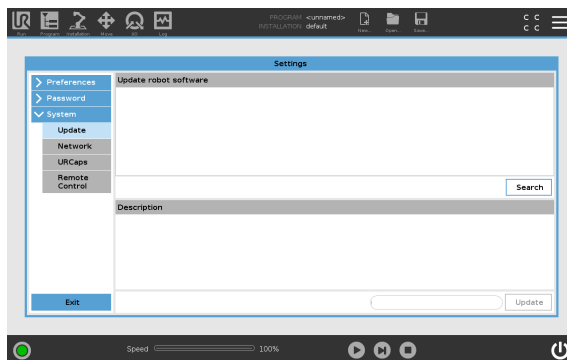

9. Select the desired software update and press Update.

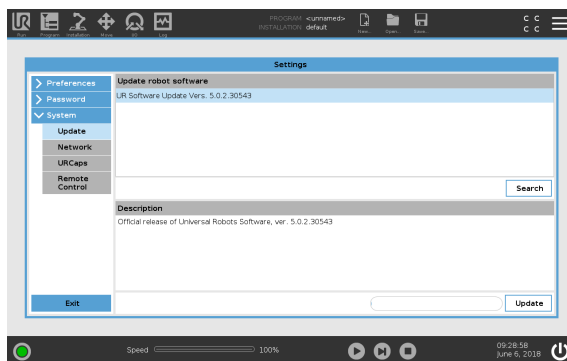

Copyright © 2009-2025 by Universal Robots A/S. All rights reserved.

- Press Install Software to update the software.

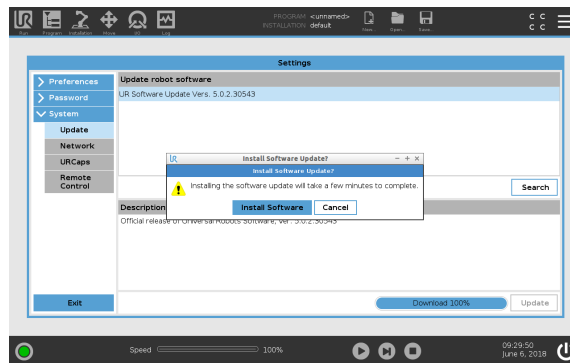

- The robot will power off and power on again. Once the update is complete, the Control Box automatically reboots. **Do not power off or unplug the robot from the outlet during startup.**
- Wait until the reboot is complete. Firmware for the control Box and Tech Pendant is updated.
- When complete, go to the Initialize screen and press ON, if available joint firmware is going to update.

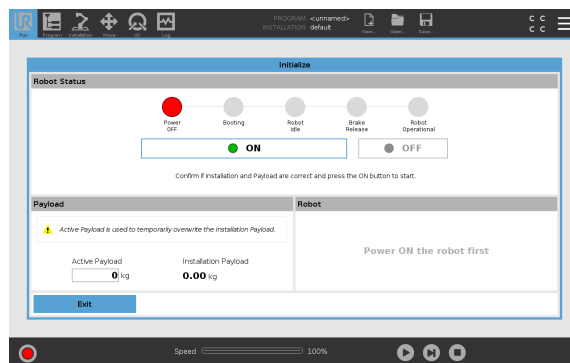

- Remove the USB stick.
- If it is the case, repeat steps 4. To 14. until reaching the most updated version.
 - Note: From software version 5.5 beyond, the most updated version available in UR's website can be installed direct, no need to incrementally install updates.

More info is displayed on release notes on support site. Read it for new features releases and improvements.

6.2.2. Update Timeline

When to update

- If your software version belongs in the yellow-orange section, you need to install incrementally until 5.5.
- If your software version belongs in the blue section, you can directly update to any in the green version.
- If your software version belongs in the green section, you can directly update to a newer version.

6.2.3. Downgrading vs. Restoring System Backup

Do not downgrade

Do not downgrade the robot software to an earlier version prior to the robot's manufacturing date.
 Do not revert your robot software using older update packages if you have installed 5.8 or above software version. If, for any reason, you need to downgrade below PolyScope version 5.8, you can do so by restoring your old system backup (system backup was implemented from Polyscope version 5.5 ahead).

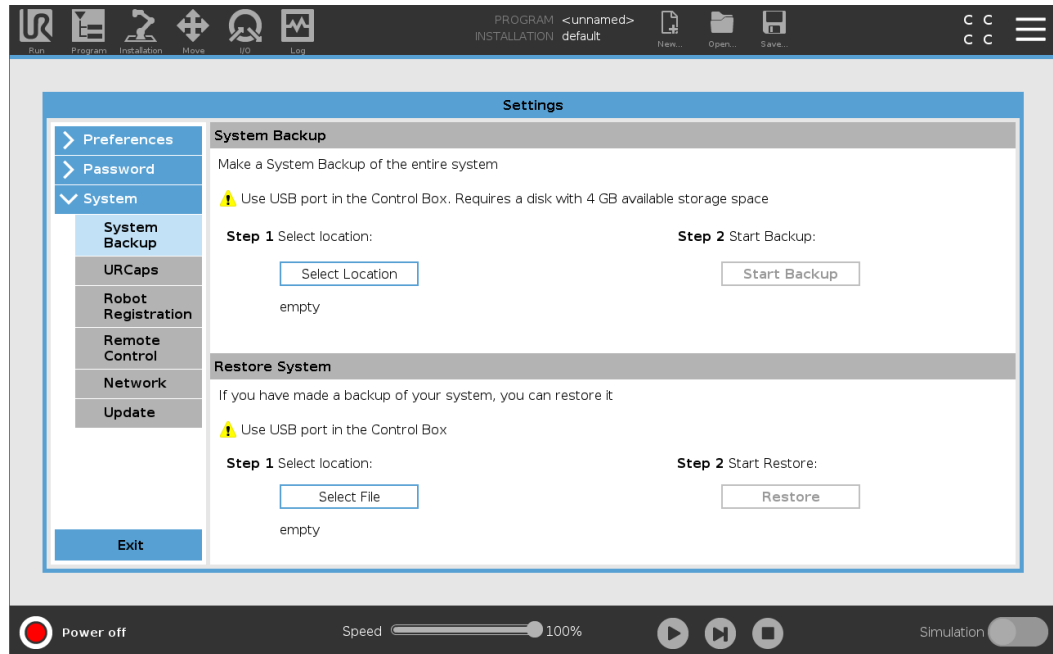

NOTICE

The system backup requires around 4Gb memory, please use a USB stick of 4Gb or more capacity.



NOTICE

Always perform program and installation files backup before updating the software.

6.3. Using Support File

For easy backup, Universal Robots provides a feature available from software version equal to or above 5.8, called Support File, an automatically copied file of the robot data from control box to the USB stick.

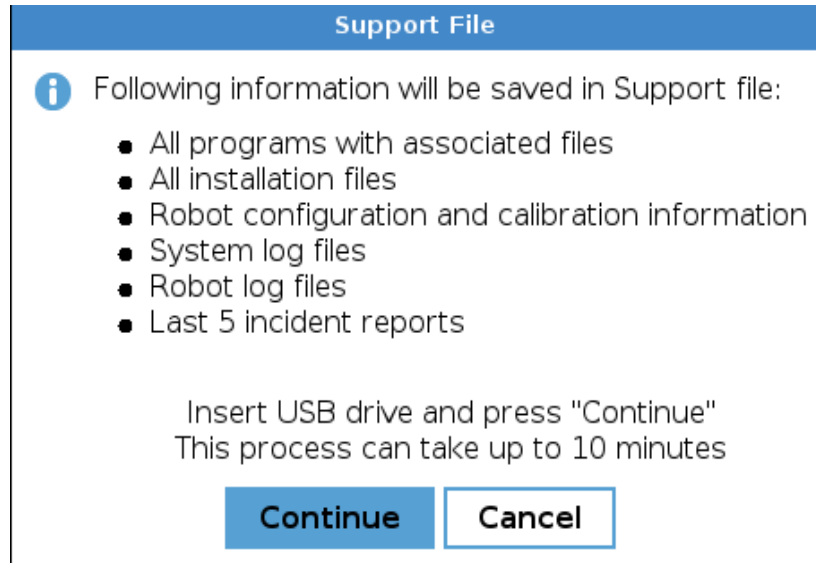

1. Go to Log tab, insert a USB stick, and click on Support File.

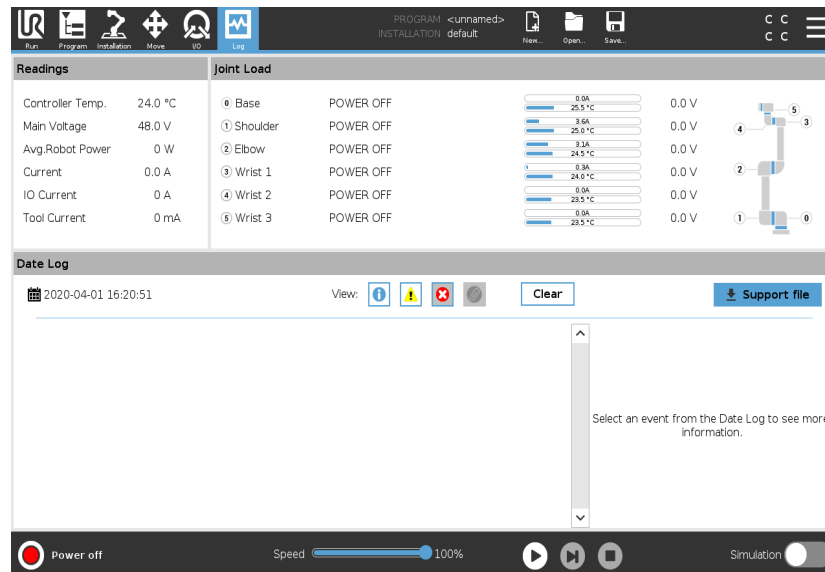

NOTICE

This backup requires around 1Gb memory, please use a USB stick of 2Gb or more capacity.



NOTICE

Always perform program and installation files backup before updating the software.

Copyright © 2009-2025 by Universal Robots A/S. All rights reserved.

6.4. Using Magic Files

For easy backup, Universal Robots provides magic files to automatically copy data from the control box to USB stick. Magic files back up works with all software versions, but starting with version 5.11, execution of magic files could be disabled in general security settings.



NOTICE

Always perform program and installation files backup before updating the software.

Available File	Function
URmagic log file	Copies the entire log history file to USB stick
URmagic backup programs	Copies all programs and installation files to USB stick
URmagic configuration files	Copies all configuration files to USB stick
URmagic upload programs	Copies all programs and installation files from a USB stick to the robot
URmagic screenshot	Generates a screenshot of GUI when USB stick is inserted

You can download magic files at: www.universal-robots.com/support

1. Download and save magic files to the root folder on a USB stick. If more than one magic file is on the USB stick, they run in sequence. Warnings appear for each file. Do not remove the USB stick until the last file is finished. Multiple folders are created and named with serial number as well as a sequence number (e.g., 201855xxxx_0, 201855xxxx_1).
2. Insert the USB stick into the USB slot in the controller box or on the top right side of the teach pendant.
3. A red **!USB!**-sign appears on the screen. Do not remove the USB stick.
4. Wait for a green **<-USB**-sign to appear. If more than one magic file is on the USB stick, proceed to step 3.
Note: Large files (e.g., history log) may take up to two minutes to download.
5. After the last magic file is completed, the USB stick can be safely removed.

The magic file creates a folder on the USB stick named with the serial number of the robot.

6.5. Backup of Data

Data backup**NOTICE**

When copying/moving files and folders, incorrect use might corrupt the file system.

Contact your IT professional for assistance if you are not comfortable with this procedure.

This section explains the process of moving required files during a robot backup.

6.5.1. Hardware Requirements

The following hardware is needed:

- SD card (Universal Robots 4GB industrial grade SD card)
- A standard SD card reader

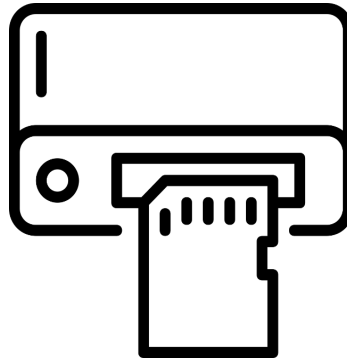

6.5.2. Software Requirements

When using Windows operation system, a software file system driver is required to read a Linux partition. In this example, we are using “Linux File Systems for Windows” by Paragon, but other Windows Linux reader can be used as well (these are, however, not tested by Universal Robots).

**NOTICE**

“Linux File Systems for Windows” by Paragon software is a third-party software.

Universal Robot takes no responsibility for this software.

6.5.3. How to Access Linux Partition from Windows

Linux partition With the software from Paragon, you can access all partitions on the SD card. The files needed are located on the partition called **datafs**

If the partition is not shown, it could be that it is not mounted automatically. To correct this:

1. open the Paragon software,
2. select the partition,
3. select the mount icon,
4. select the volume drive letter, and
5. mount.

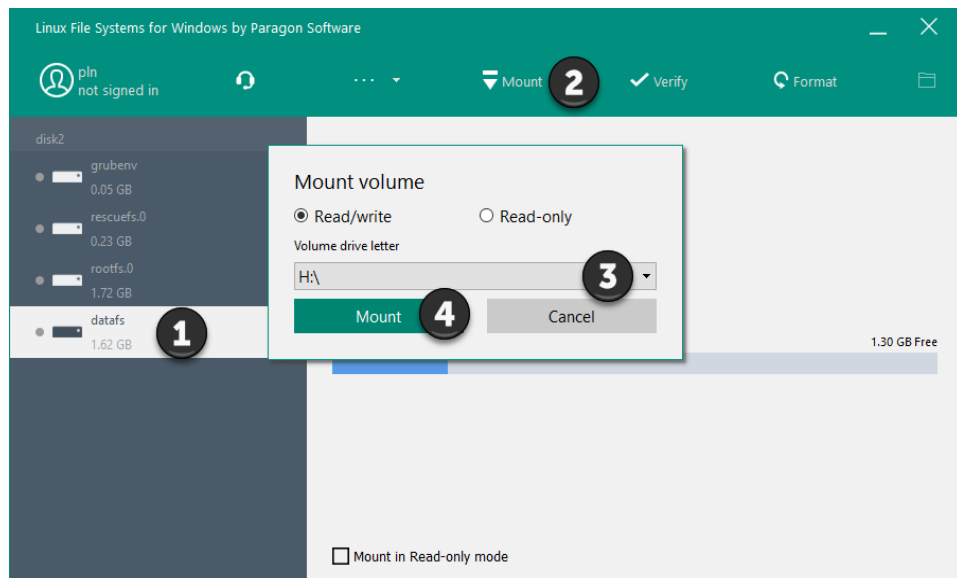

6.5.4. Copy the Data from SD Card

Datafs

Navigate to the SD card partition called **datafs** and copy the listed files/folders below.

**NOTICE**

Do not alter any files. You must only take backup copies as needed.

- programs/ [all of the following files: .urp, .txt, .script, .installation, .variable, .old]
 - root/ur-serial
 - root/log_history.txt
 - root/log_history.bak [if existing]
 - root/histogram.properties
 - root/flightreports [Complete folder if existing]
 - root/.urcontrol/calibration.conf
 - root/.urcontrol/calibration.log
 - root/.urcontrol/robot_calibration_summary.txt
-

7. Troubleshooting

7.1. Adding External Equipment for Troubleshooting Purpose

Add External Equipment

For troubleshooting, it can be useful to add a mouse, keyboard, or monitor. Most USB mouse and keyboards are supported. Plug in the mouse or keyboard in one of the available USB ports. A restart of the the control box may be required for it to work.

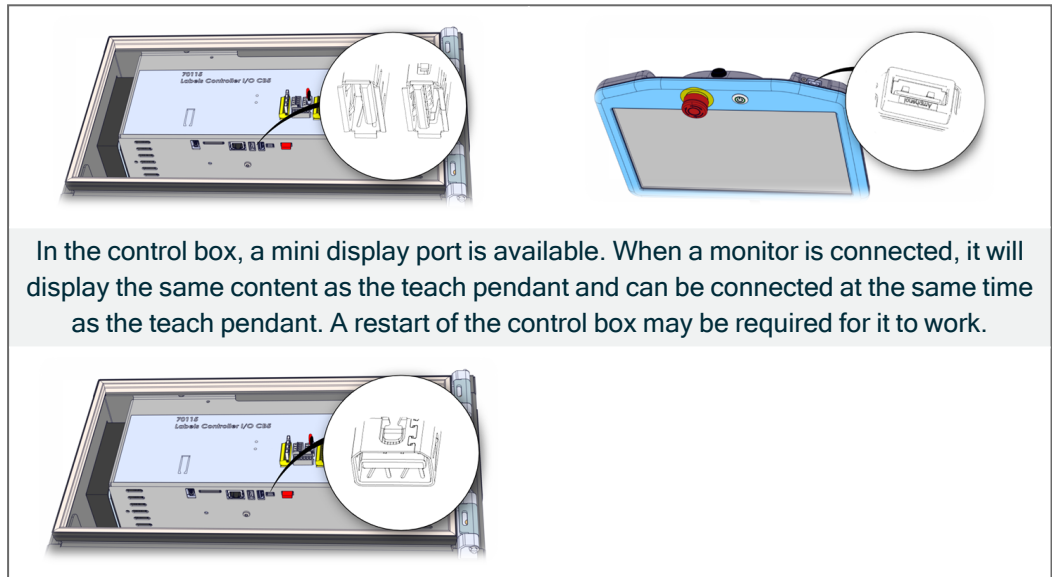

7.2. Log Viewer

Specifications

Compatible robots: UR3, UR3e, UR5, UR5e, UR10, UR10e, UR16e, and UR20
 Controller versions: CB3 & e-Series
 Software versions: CB3: 3.4 and higher. e-Series: 5.0 and higher, PolyScope X.
 UR Log Viewer version: 1.3.2
 Documentation version: 1.3.2

7.2.1. General Purpose

Purpose

The purpose of the UR log viewer manual is to help Universal Robots (UR) users and integrators to perform service-related analysis and understand robot behavior to support any enhancements and needed troubleshooting.

Universal Robots industrial robots are designed using high-quality components to ensure a long lifetime. However, improper use of the robot or robot parts can potentially cause unexpected failures due to misuse. If, for example, the robot is overloaded, dropped during relocation, damaged by collision or any other improper usage, the warranty will be void. Universal Robots recommends the user not to repair, adjust, or make other interventions in the mechanical or electrical systems of the robot without first being trained and consulting a UR-certified service engineer. Any unauthorized intervention voids the warranty. Service-related operations and troubleshooting should only be performed by qualified personnel.

Before performing service-related operations, stop the robot program, power it off, and disconnect the main power input to any potentially dangerous tool on the robot or the surroundings.

In the event of a defect, Universal Robots recommends ordering new parts from the Universal Robot distributor where the robot was originally purchased. Alternatively, parts can be ordered from the nearest distributor, details of which can be obtained from Universal Robots official website at www.universal-robots.com

7.2.2. Log Viewer Requirements

Intention

The UR log viewer is a software intended for reading and viewing the Support File from the Universal Robot's cobots, which are generated automatically inside each robot, and contain the log files, programs and flight reports. The software is a support tool for the user of the robot to do troubleshooting in case needed. It is a tool for understanding the robot behavior and have data analysis, as well to do improvements on your application and programming.

The Log Viewer is applicable for the following robots: UR3, UR3e, UR5, UR5e, UR10, UR10e, UR16e and UR20.

Requirements:

- To install and execute the UR Log Viewer you need the following requisites:
 - OS Windows 7, 8, 8.1 or 10 - current version doesn't work on Linux or Mac.
 - .Net 4.8 minimum installed.
 - User access defined to be able to install and execute the software
 - Works with Polyscope SW versions:
 - CB3: 3.4 and higher
 - E-series: 5.0 and higher
 - PolyScope X
-

7.2.3. Installation Log Viewer

Downloading

Download UR Log Viewer

First step is to download the UR Log Viewer's software from Universal Robot's website: www.universal-robots.com/download. Choose robot version: CB-Series or e-Series ->

Software -> UR Log Viewer

Installation

1. To install in your computer, you first need to:
2. Unzip the file in your computer.
3. Double click on the UR Log Viewer Setup file in the folder.
4. Run as administrator if needed.
5. Then follow the instructions shown on your computer screen:

7.2.4. How to Use the UR Log Viewer

Purpose

The purpose of the tool is to read, analyze and examine robot data from e-Series and CB3-Series robots. Any findings based on this tool is the sole responsibility and interpretation of the user. To have a final saying in case of service needs, please refer to your distributor or Universal Robot's technical supporter for guidance on service, trainings and warranties.

The following files are supported:

Support File (implemented on SW 3.13 and 5.8 forward): ex.:ur_20195099999_2020-07-16_09-24.zip

Service File (via "urmagic_data_capture_v0_6_X.sh"): ex.:ur_service_20235XXXXXX_2023-09-08_16-50-24.zip

Flight Reports: ex.: recording20200520_17_59_14.zip

Log History: ex.: log_history.txt, log_history.bak

Real-time recordings: Created by UR Log Viewer: ex.: recording.csv

7.2.5. Loading the Data

The available file can be either dragged and drop on the Log Reader tab or opened by selecting the path where the file is stored in your computer.

A third option is by selecting it directly from Windows, using right-click on the file -> open with -> choose another app -> UR Log Viewer.

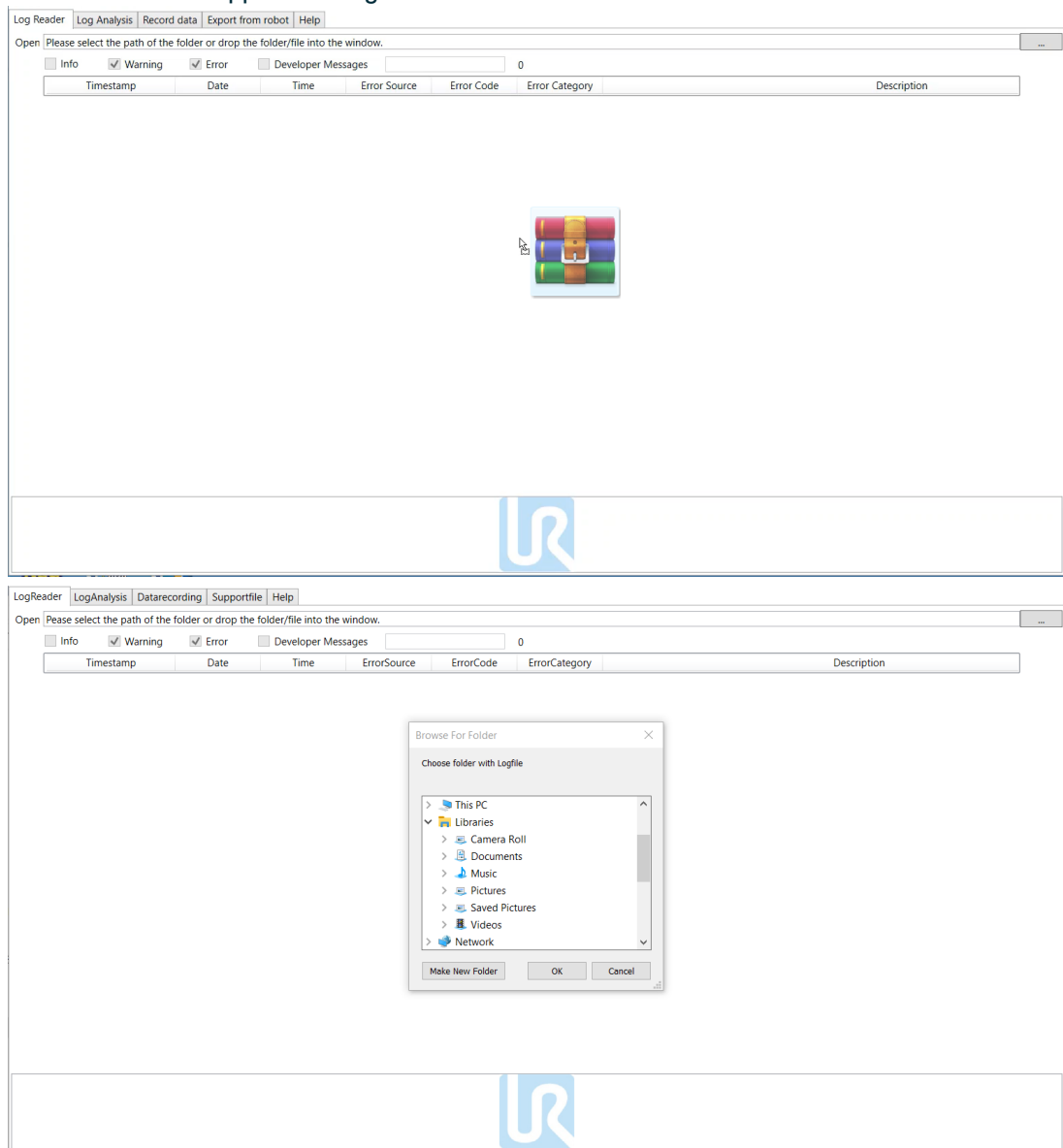

NOTICE

If you try to load the file and it doesn't allow you to do so, please restart your software and try it again. Make sure you have the correct file while loading. If you need any support or service, consult your local Universal Robots distributor or Universal Robot's website.

7.2.6. Log Reader Tab

Use this tab to load the desired support file. If a log file is loaded, you can choose which types of messages to be shown.

Once the file is loaded you will have the option of choosing which types of messages to be shown on the Log Reader screen, the options are:

- Info
- Warning
- Error

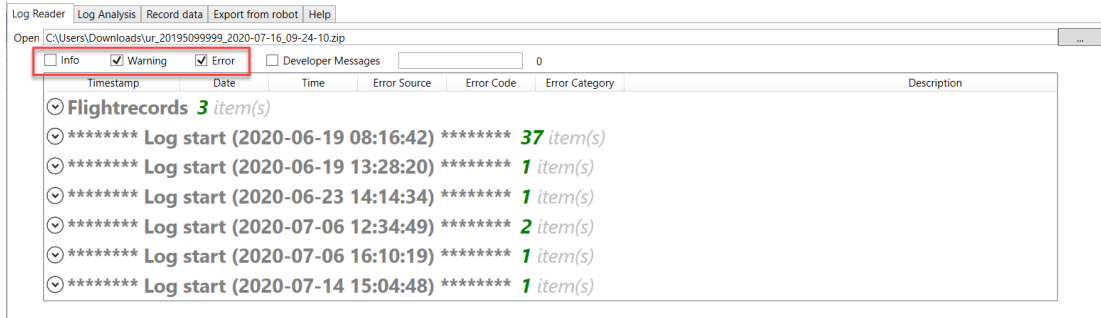

NOTICE

"Developer Messages" are intended for expert-level users only. Please use it only if advised.

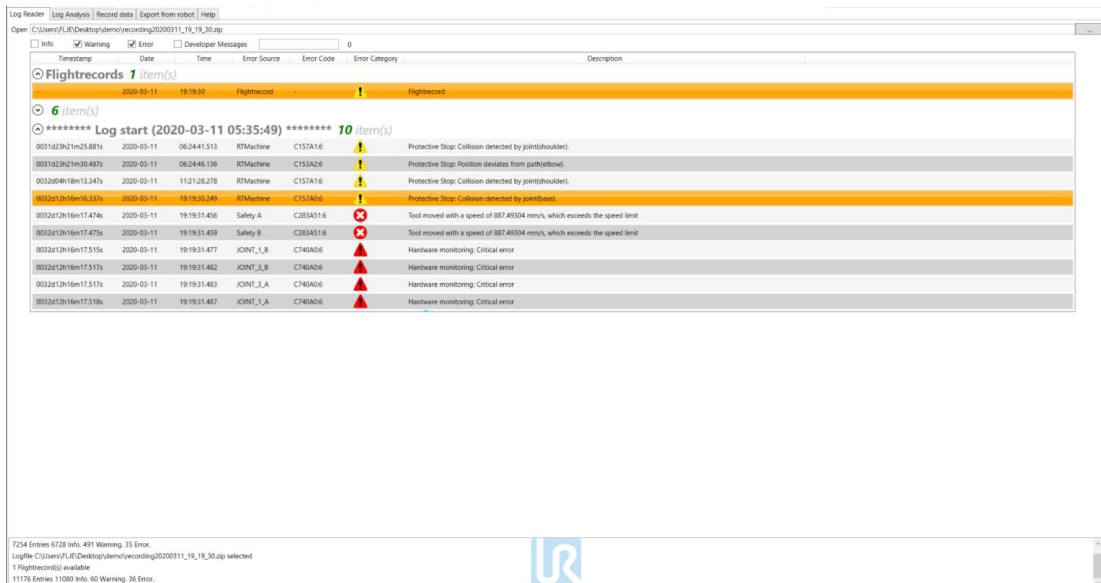

The user will see the Flight Records section only when opening a Support File, Flight Report file or Real-time Recordings data file, if you open a Log History file, you will only see the Log Start section with the info, warnings and error codes and their respective entries.

7.2.7. Flight Records

The Flight Records section gives the user the capability of generating graphs from the stored data on the mentioned files above. To open the standard graphs, double-click on the Flight Record entry to open the graphs of the data recordings.

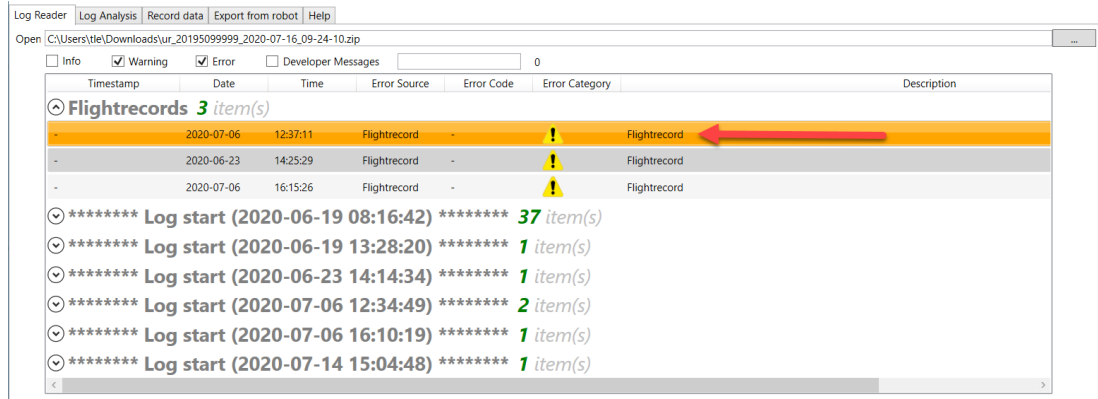

This will open 6 new windows with real-time data graphs for the selected Flight Record. Each opened window contains data for the respective joint and the data of the exact moment of the fault that has happened on the robot.

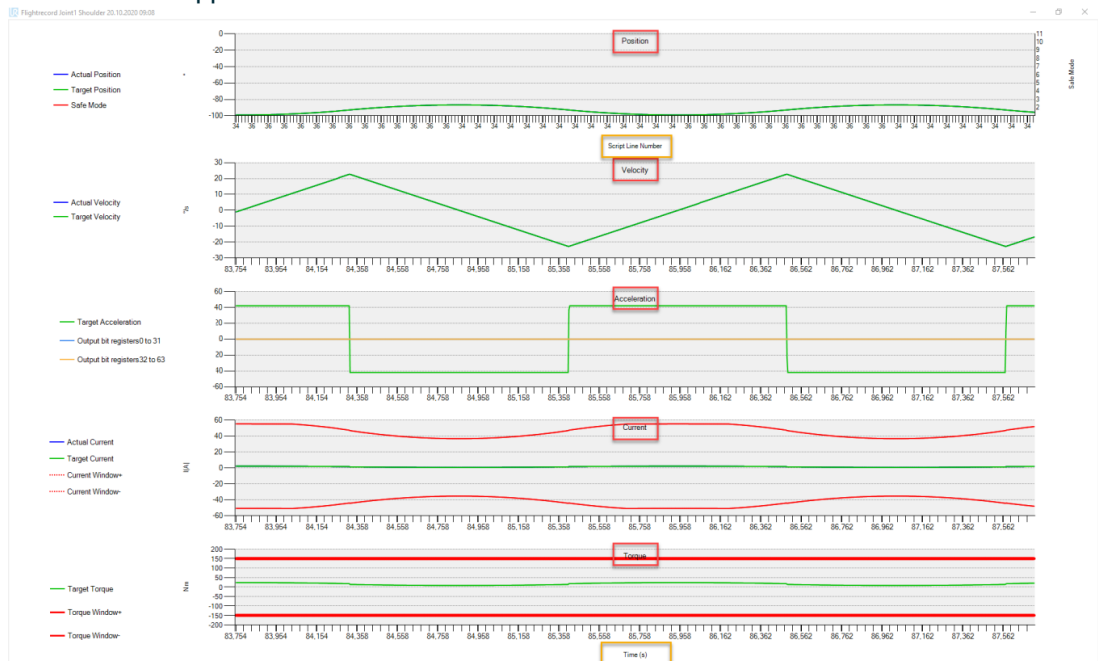

Representation of the standard graph window at the exact fault recorded data from joint Shoulder. The standard generated graph contains information of the robot behavior when it had the fault. The information shown on the standard graph is: Position, Velocity, Acceleration, Current, Torque.

The X axis shows the script line number of the program or the index of the data point, if available. If you need any other graph to be generated, the user has the option of choosing other data variables by right-clicking on the Flight Record and choosing on the seen drop-down list:

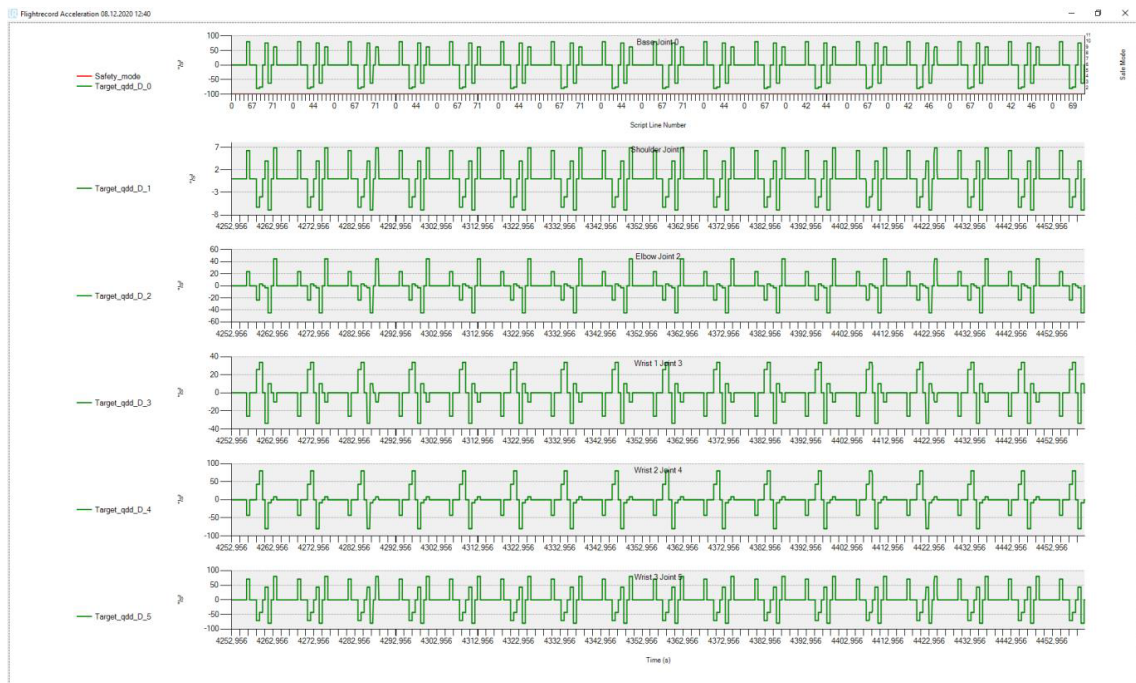
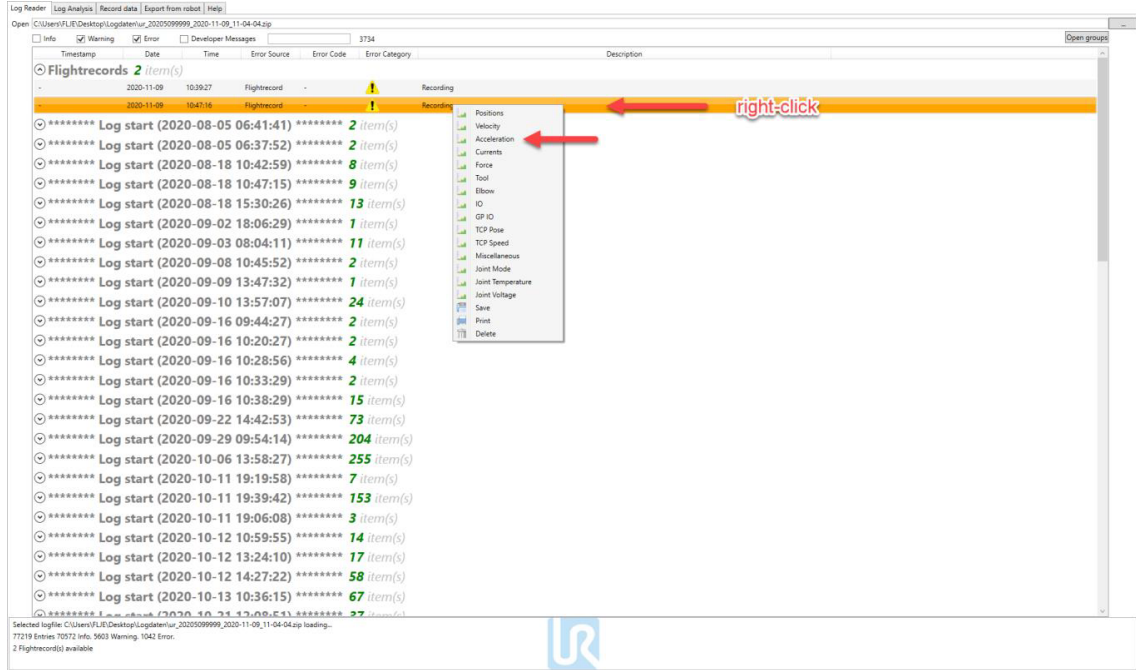

Example of a personalized graph generated of all joints by right-clicking on chosen Flight Record and picking acceleration at the time of the fault.

Copyright © 2009-2025 by Universal Robots A/S. All rights reserved.

7.2.8. Log Start

To read the log history section, you must click on the Log Start arrow to open and be able to read where the entries from the robot will be shown accordingly to its date and time and the type of message. The description of the message, error category, error code, error source, time, date and time stamp will be shown after opening the log start entry. You can also press the “Open groups” button to open all grouped entries.

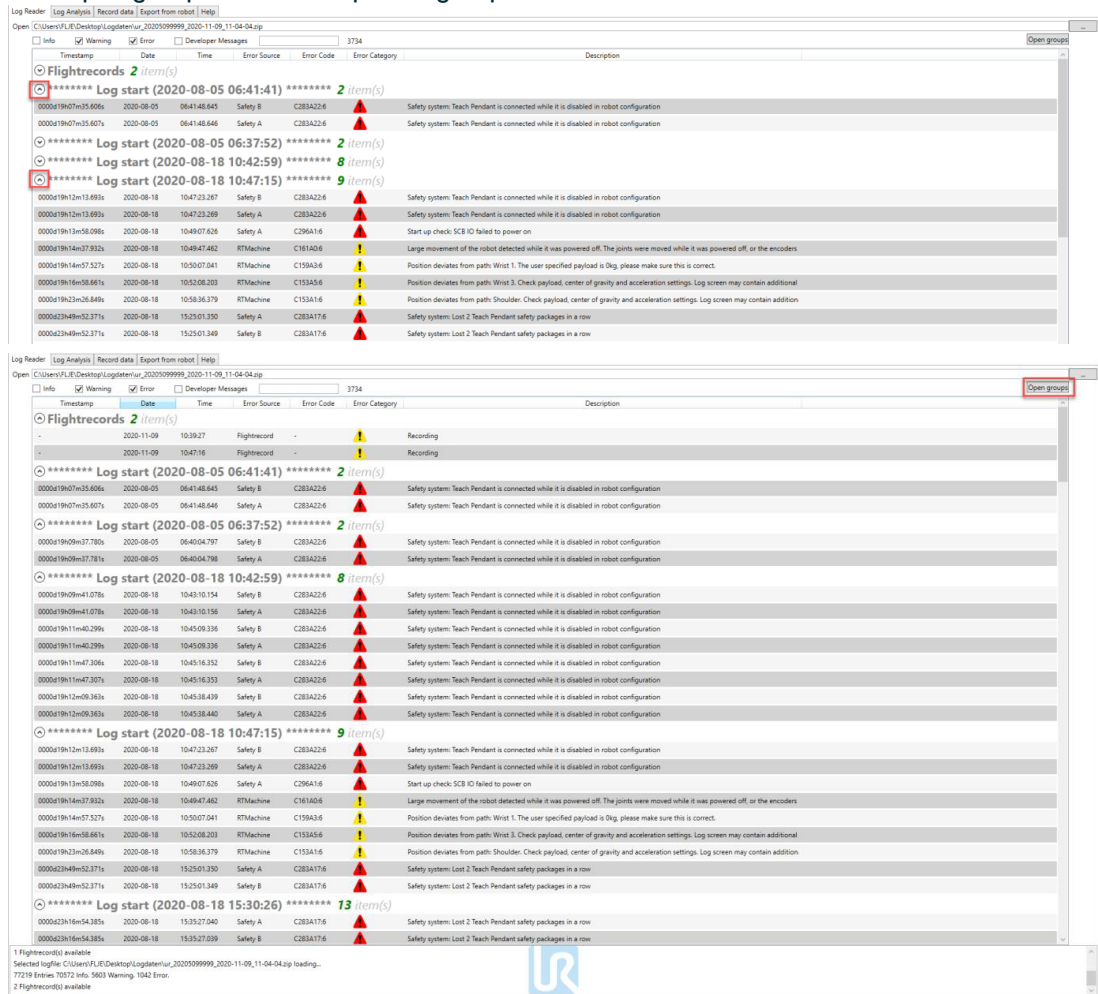

Example of a window showing warning and errors from a log start entry

By right-clicking on the Log entry and choosing “Error Default Timeline” or “Error Selection Timeline” a new window will be displayed. It shows you the occurrence of errors over the time. Here you can switch the displayed range of errors, change the type of chart and switch to an accumulated view.

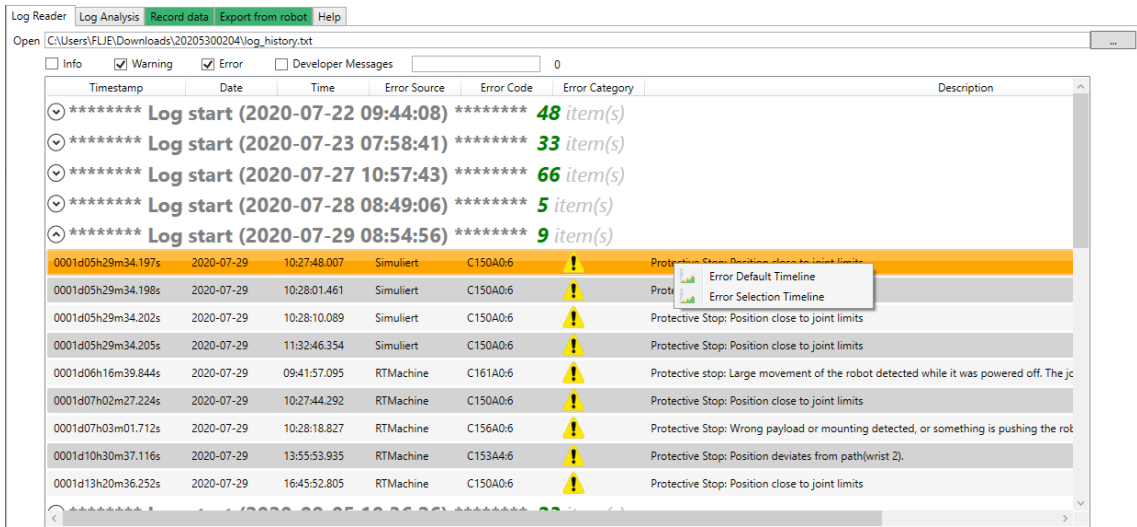

Context menu for Error Timeline Charts

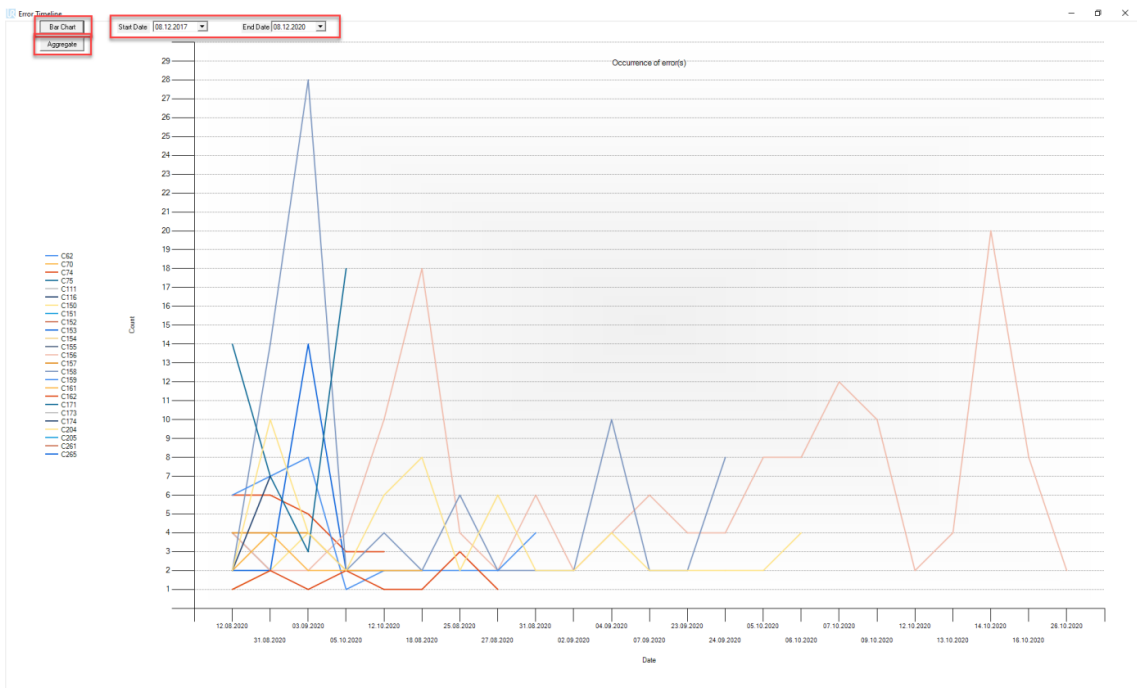

Example of a window showing Error Default Timeline

Shortcuts:

- CTRL+C: Copy the selected Log History line.
- CTRL+E: Copy the error codes of the selected Log History line(s). You can select many lines and click the shortcut to copy the codes.

Copyright © 2009-2025 by Universal Robots A/S. All rights reserved.

7.2.9. Log Analysis Tab

Use this tab to see a summary of important error codes found in the loaded file. You can select different time frames to see the progress of your robot in time.

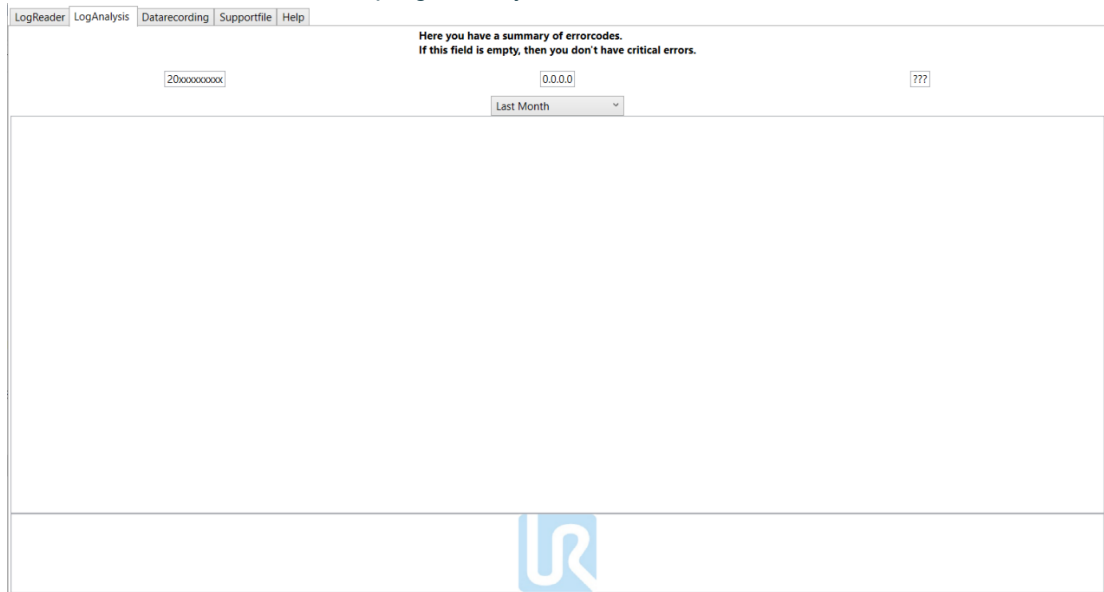

The Serial Number of the robot, the robot software current version, and the last program running on the robot will be displayed on this screen for information.

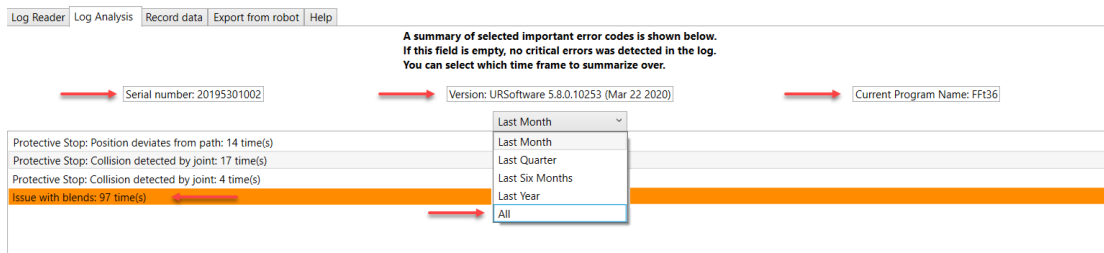

If a high number of critical error codes are found, they will be highlighted on the list for awareness and corrective actions to be taken by the user to solve the source of the message.



NOTICE

If you have a high number of messages shown up on the Log Analysis tab, take action to try to solve the source of these error/warning messages generation. It is not right to have many messages showing up on the robot, they need to be acted upon.

7.2.10. Record Data Tab

**Description
Function**

This tab enables the real-time data recording of the robot connected through ethernet cable with your computer.
 Before starting to record any data, make sure you have your computer connected to the robot's ethernet port and you have setup your computer's IP address on the same range of the robot's IP address. Make sure your firewall is not blocking the connection from happening and make sure RTDE Interface is enabled "on" robot security.
 After you have the connection done, select the relevant data fields you want to be recorded. The frequency of update can be defined as wanted. You can adjust sample time and measurement duration for the recording. We advise keeping the default values not to create high memory consumption. Press "start" on the right top corner for the data recording to begin.
 Continue record enables long record periods. If selected a new record file will be saved periodically, depending on the setting time of the auto record field. We recommend for long terms 100Hz and 5 minutes. This has the reason of memory consumption and for better analysis.



NOTICE

High frequency combined with long sample periods leads to big data traffic recordings, potentially affecting memory consumption on some systems.

After starting to record, the data will be available in the Log Reader's tab. Please check if your robot's software version has all selected data field available, if not, update your robot to the latest software version for complete usage experience.



NOTICE

Please notice that the button "save last record" only saves the last record started. If there were many records started and stopped, and you want to save the others, go to the Log Reader tab, right-click on the previous Flight Record you want to save, and press save. The previous ones are not saved automatically and if you close the software they will be lost.

Shortcuts:

- CTRL+A: Select all check boxes
- CTRL+N: Select the default check boxes

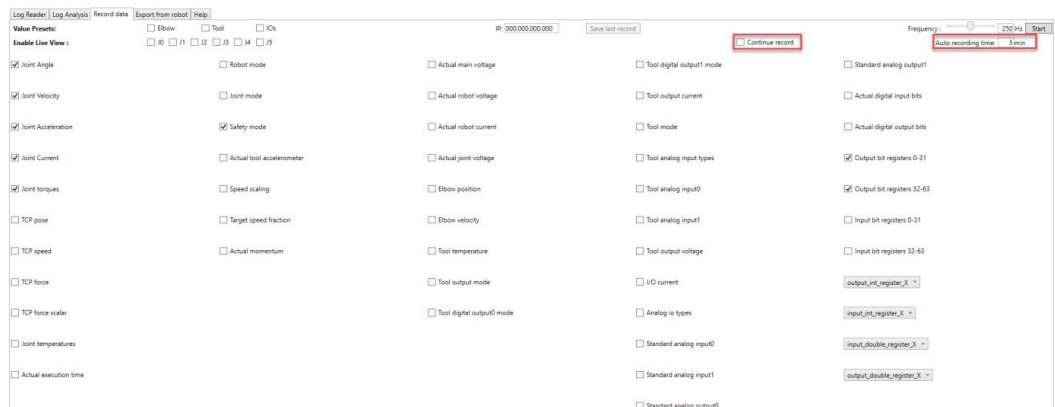

7.2.11. Export From Robot Tab

Exporting data The Export from Robot tab allows you to create and export the Support File from your connected robot via ethernet connection to the computer. Refer to 2.5.5 Record Data tab topic in this manual, to understand how to connect the robot's and computer IP addresses. For older robot software versions (PolyScope 5.7 and 3.12 below) the Log History and Flight Reports are retrieved instead of the Support File. After the download the user will be asked, if he/she wants to open the pulled data directly on UR Log Viewer or just store in the computer.

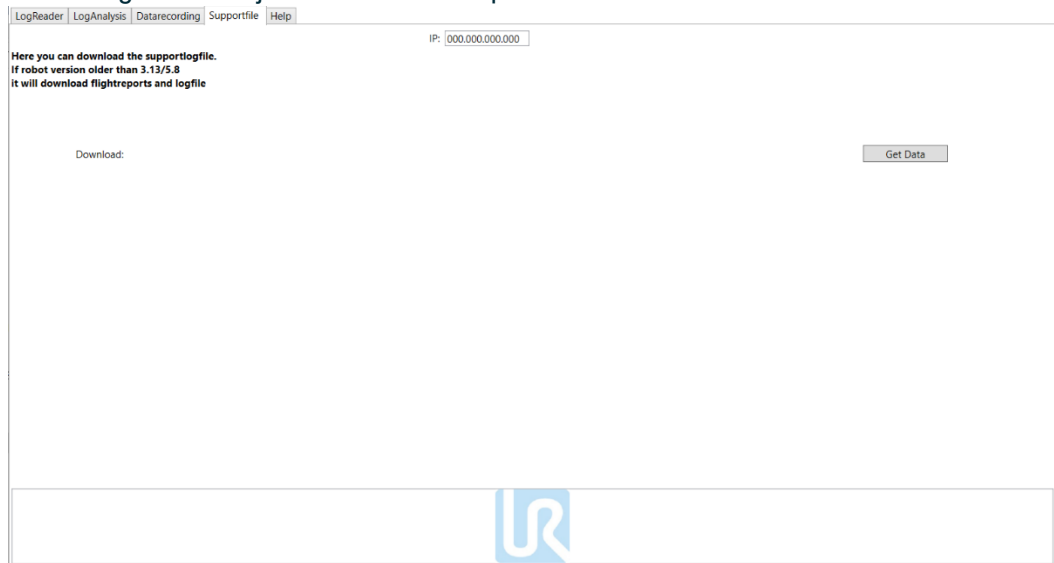

7.2.12. Types of Messages

Message types

Message's icons in this document contain information that helps you to understand and troubleshoot the robot.

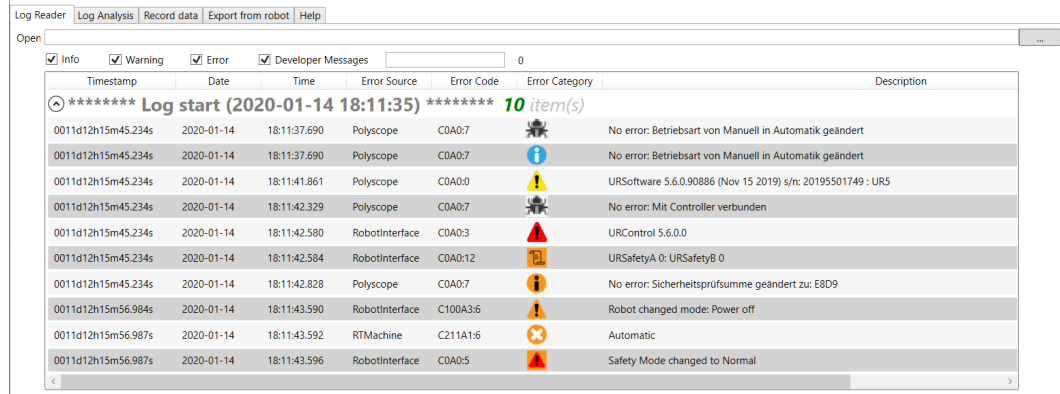

The Symbols are the same as in the protocol tab from Polyscope.

- Debug Message
- Info Message
- Warning Message
- Error Message
- Fault Message
- Developer Message
- Developer Message
- Developer Message
- Developer Message
- Developer Message



Copyright © 2009-2025 by Universal Robots A/S. All rights reserved.

7.3. Support Log Reader (SLR)

Steps

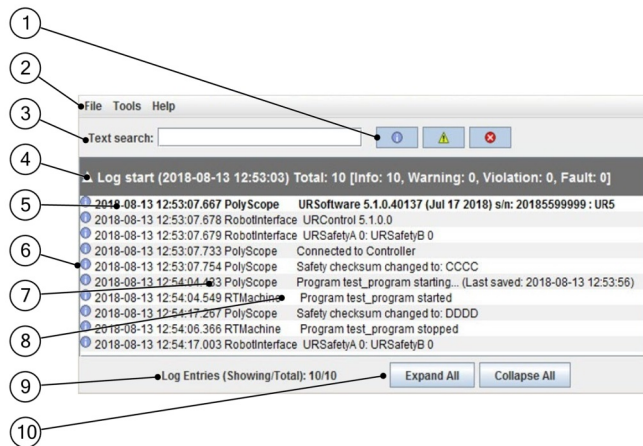
Open log files with the Universal Robots Support Log Reader (SLR).
Go to www.universal-robots.com/support to download the Support Log Reader



1. Filter;
Select what filter to activate
Info filter: 
Warning filter: 
Error filter: 
2. Tool bar;
Load log files, export error codes, change language
3. Text search;
Type error code or text
4. Log start Info bar*;
Created every time the robot is powered on.
5. Highlighted text;
When tapped, gives more detailed Information.
6. PolyScope time
7. Reporter;
Where the info is reported from "safety, PolyScope, etc."
8. Message;
Text with the Cxxxx refers to the error codes.
9. Log Entries;
Shown and total
10. Expand or collapse all Info bars (point 4)

**NOTICE**

After loading the log file every Log Start Info Bar (4) is collapsed and only the summary for each log start is visible.

7.4. LED Indicators and Fuse on Safety Control Board

7.4.1. LED Indicators on Safety Control Board

The below LEDs are “power” LEDs. They are either on or off.

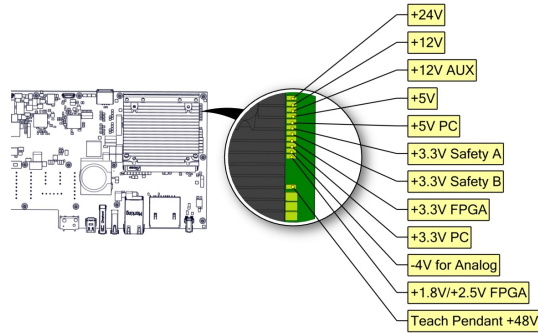

LED for power

- Green color permanent = Power on
- No color permanent = Error or no power

Below are “communication” LEDs. They flash in different patterns, depending on the status.

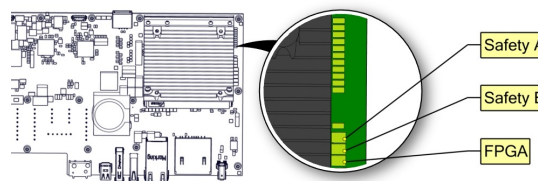

LED for Safety A and Safety B

Green fast flash = Bootloader

Green slow flash = Normal communication

Red permanent = Error (Red flash can happen during bootup/power on, this is normal.)

LED for FPGA

Green/Red permanent = Normal communication

Green slow flash = No communication/trying to establish communication

7.4.2. Fuse

Fuse is a 10A fast-acting mini blade fuse.

**WARNING**

Never use a different fuse than specified. Only use high grade components.

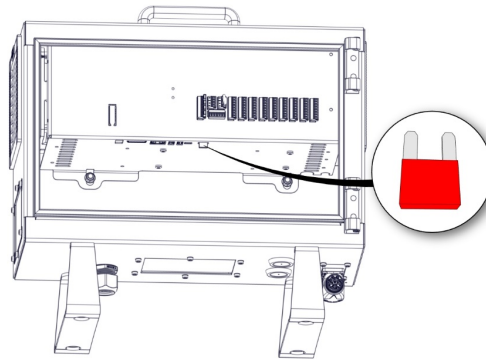

Fuse specifications:

- Interrupting Rating: 1000A @ 32 VDC
- Voltage Rating: 32 VDC
- Component Level Temperature Range: -40°C to +125°C
- System Level Temperature Range: -40°C to +105°C
- Terminals: Ag plated zinc alloy
- Housing Material: PA66
- Complies with: SAE J2077, ISO 8820-3
- UL 248 Special Purpose Fuses

7.5. Complete Rebooting Sequence

Diagram showing rebooting steps

To completely reboot the robot system, follow the following steps:

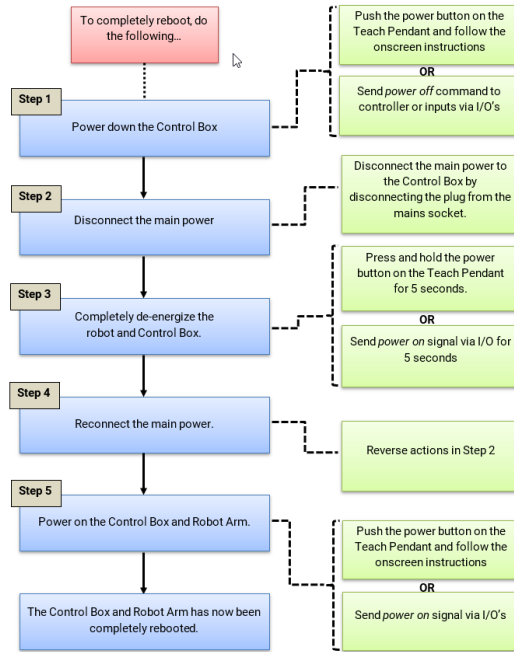

7.6. Protective Stop

Yes-No Flowchart

Read also article 18939 on the support site www.universal-robots.com/support

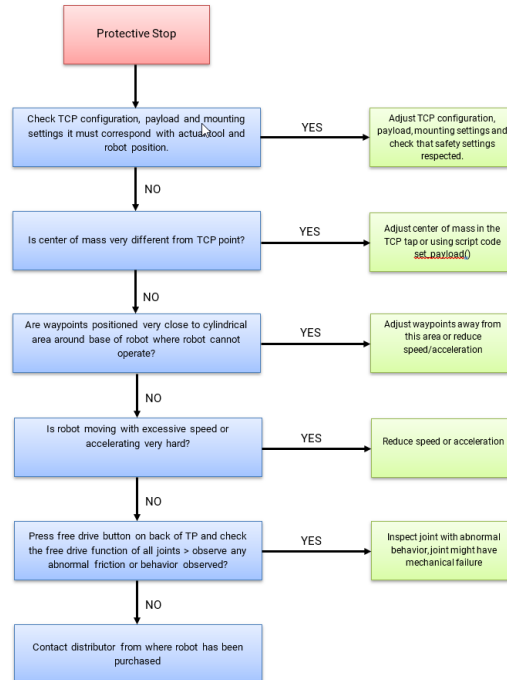

7.6.1. Preventive Measures

Preventive Measures

Ignoring protective stops is considered abuse of the robot which voids the warranty. These faults can be hidden from view under the following two circumstances:

1. Personnel simply resetting a fault without review of why the fault has happened.

**WARNING**

Ignoring protective stops masks fault detection, which can increase the risk of injury.

- Pay careful attention to protective stops. Learn why they happen to improve your programs and preserve fault detection.

Protective stops must never be acknowledged and reset automatically, it must always be a deliberate action by a user to resume after a protective stop.

In general, protective stops are designed to inform the user that the robot has stopped due to an external event such as hitting an obstacle or similar. In case the robots are pushed close to the limits, the robots can generate protective stops to indicate that they are not capable of following the desired trajectory. After a protective stop, the following must be done before resuming operation:

- i. If there has been a collision or similar:**
Remove the obstacle and ensure that operators are out of the way before resuming operation. See Section 2 of Service Manual (see link below).
- ii. If there has been NO collision or similar:**
The robot is operating too close to the limits, the application should be adjusted to reduce the load on the robot, for instance by reducing accelerations, by correct use of blends or similar measures.

Protective stops are indications of issues, including program or production issues - not only safety issues. An application which results in daily protective stops is not designed correctly and needs to be modified.

2. If an automatic acknowledgment and reset of a protective stop has been programmed - no one will see the protective stop.

**NOTICE**

Automatic acknowledgment and reset of protective stops masks faults that will lead to a failure condition.

- When there is a protective stop, verify the cause. If there is no collision, adjust the program

If an integrator has set-up the application program to do automatic acknowledgement and reset of protective stops, the customer should contact the integrator change the program immediately, as such override voids the product warranty and masks fault detection.

8. Electrical Drawings

Schematic Diagram

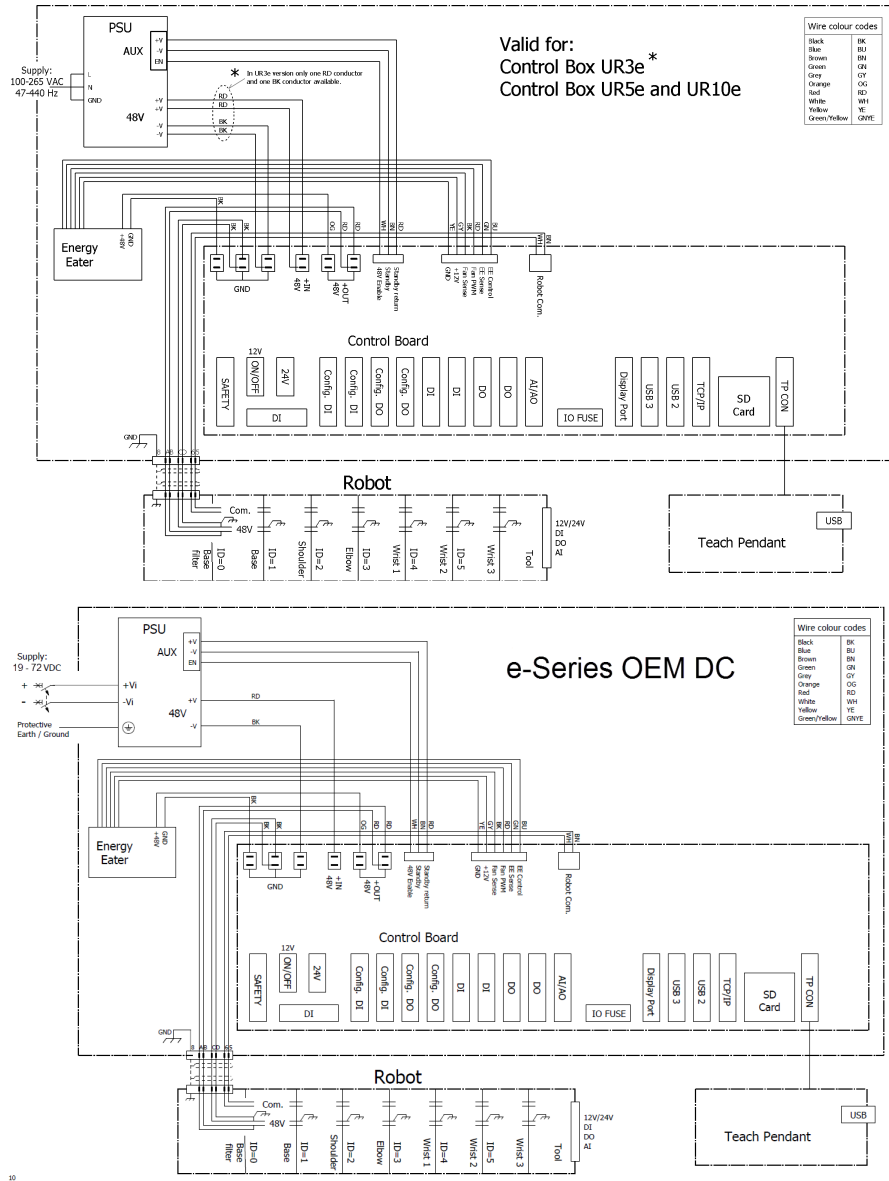

Copyright © 2009-2025 by Universal Robots A/S. All rights reserved.

9. Spare Parts

See Support
Section of
UR website



NOTICE

Ensure you have the correct part numbers when ordering spare parts.

The full list of spare parts have been moved to the support section on Universal Robot's website: <https://www.universal-robots.com/support/>

10. Packing and Shipping of Robot/Spare Parts

Before shipping any robots or spare parts back to Universal Robots, please note the following



NOTICE

Remove external tools and external electrical connections before shipment. Universal Robots may reject the shipment if third party products cannot be unmounted safely, or if they prohibit the execution of required post repair tests.

Universal Robots assumes no responsibility for the return shipment of third party goods.

Ensure the robot, Control Box, and Teach Pendant are packed responsibly. Universal Robots will return Universal Robots products in original Universal Robots packaging.



NOTICE

The robot software/firmware is updated when repaired. New parts are also updated to their newest versions (hardware/software). Therefore, updating PolyScope may be necessary when new parts are mounted.

MANDATORY ACTION

If the robot/part(s) has been in contact with, or worked in environments, where dangerous chemicals or materials are present, it must be cleaned before shipment. If this is not possible, the shipment must be accompanied by an MSDA (Material Safety Data Sheet) in English and include instructions for cleaning. The amount of labor hours needed for cleaning will be billed at the standard rate.

If Universal Robots finds the robot/part unsafe to service, UR reserves the right to get the robot/part(s) cleaned or decline the case and send the part(s) back at customers expense.

Packing Down the Robot and Control Box for Shipment

1. Download the put_in_box program at: www.universal-robots.com/support
2. Upload the put_in_box program. See Section 5.2 Using Magic Files on how to do this.
3. Load the program and follow the instructions when running the program.
4. Power down, disconnect main power, and disconnect the Robot Arm from controller.
5. Pack the Robot Arm and Control Box in designated boxes. Ensure the Robot Arm is orientated correctly in the box.



NOTICE

If the robot is attached to 3rd third-party application/ installation during transport, please refer to the following:

- Transporting the robot without its original packaging will void all warranties provided by Universal Robots A/S.
- If the robot is transported as part of a prefabricated solution, securely mounted, and in full compliance with the recommendations outlined below, it is not considered a breach of warranty.

You can see the recommendations for transportation without packaging on help.universal-robots.com/

10.1. Transport Without Packaging

Description

Universal Robots always recommends transporting the robot in its original packaging. These recommendations are written to reduce unwanted vibrations in joints and brake systems and reduce joint rotation.

If the robot is transported without its original packaging, refer to the following guidelines:

- Fold the robot as much as possible. Do not transport the robot in the singularity position.
- Move the center of gravity in the robot as close to the base as possible.
- Secure each tube to a solid surface on two different points on the tube.
- Secure any attached end effector rigidly in three axes.

How to transport

Fold the robot as much as possible.

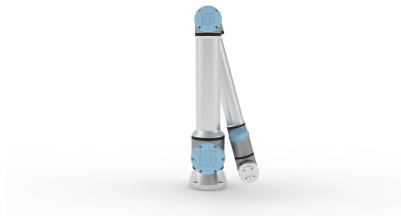

Do not transport extended. (singularity position)

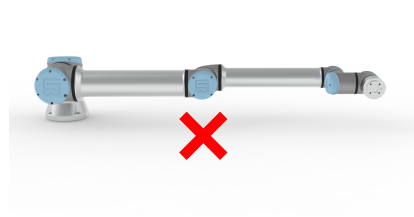
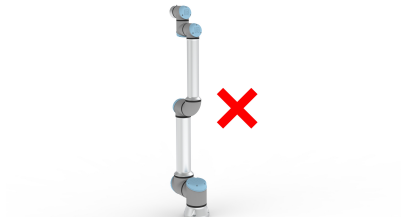

Secure the tubes to a solid surface. Secure attached end effector in three axes.

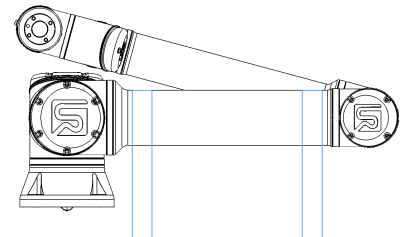
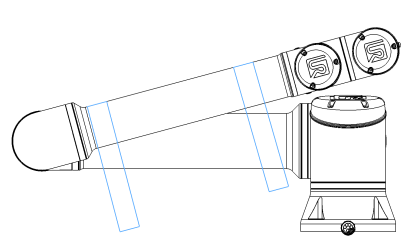

Software Name: PolyScope 5
Software Version: 5.23
Document Version: 10.14.150