



UNIVERSAL ROBOTS

Service Handbook

UR20 UR30

Control box 5.4/5.5



Contents

1. Introduction	1
1.1. About This Document	1
1.2. Company Details	1
1.3. Copyright and disclaimers	1
1.4. Safety Message Types	2
2. Handling ESD-Sensitive Parts	4
3. Recommended Inspection Activities	9
3.1. Robot Arm	9
3.1.1. Inspection Plan	9
3.1.2. Visual Inspection: Robot arm	9
3.1.3. Functional Inspection	11
3.1.4. Cleaning your robot	11
3.2. Control Box and Teach Pendant	11
3.2.1. Inspection Plan	11
3.2.2. Functional and Safety Inspection	12
3.2.3. Visual Inspection: Control Box	15
3.2.4. Cleaning	15
4. Service and Replacement of Parts	16
4.1. Pre-Use Assessment	16
4.1.1. Recommended Tools	17
4.2. Robot Arm	18
4.2.1. Joint Interchangeability	18
4.2.2. Connection Torque Values	20
4.2.3. Clamp Connection	22
4.2.4. Tool Flange	29
4.2.5. Replacement of Trim Plates	30
4.2.6. Joint Verification	31
4.2.7. Dual Robot Calibration	32
4.2.8. Program Correction by Key Waypoints	33
4.3. Control Box	33
4.3.1. Dismantling the Control Box	33
4.3.2. Torque Values	37
4.3.3. Replacing the 3PE Teach Pendant	38
4.3.4. Replacement of Teach Pendant Cable	40
5. Software	45
5.1. Long Term Support	45
5.2. Software Updates	45



- 5.2.1. Update Procedure46
- 5.3. Using Support File 48
- 5.4. Using Magic Files 49
- 5.5. Backup of data 49
 - 5.5.1. Hardware Requirements 49
 - 5.5.2. Software Requirements 50
 - 5.5.3. Accessing Linux Partition from Windows 50
 - 5.5.4. Copying the data from SD card 51
- 6. Troubleshooting 52**
 - 6.1. Adding External Equipment for Troubleshooting Purpose 52
 - 6.2. UR Log Viewer 52
 - 6.3. LED indicators and Fuse on Safety Control Board 52
 - 6.3.1. LED Indicators on Safety Control Board 52
 - 6.3.2. Fuse 53
 - 6.4. Complete Rebooting Sequence 54
 - 6.5. Robot Stop 55
 - 6.5.1. Ignoring Robot Stops 56
 - 6.6. Safe Brake System 57
 - 6.6.1. Finding the Faulty Joint 58
 - 6.6.2. Validate Joint Brake System 59
 - 6.6.3. Clearing the Brake System Error 59
- 7. Electrical drawings 61**
- 8. Spare Parts 62**
- 9. Packing and Shipping of Robot/Spare Parts 63**
 - 9.1. Transport Without Packaging 67
- 10. Change log 68**

1. Introduction

1.1. About This Document

The purpose of the Service Manual is to help Universal Robots (UR) users and integrators to safely perform service-related operations and troubleshooting.

Universal Robots industrial robots are designed using high quality components to ensure a long lifetime. However, improper use of a robot or robot parts can potentially cause failures. If, for example, the robot is overloaded, dropped during relocation, damaged by collision, or any other improper usage, the warranty will be void.

Universal Robots recommends the user does not attempt repair, adjustment, or make other interventions in the mechanical or electrical systems of the robot without first consulting a UR certified service engineer. Any unauthorized intervention voids the warranty. Service-related operations and troubleshooting should only be performed by qualified personnel.

Before performing service-related operations, stop the robot program and disconnect the main power to any potential dangerous tool on the robot or in the surroundings.

In the event of a defect, Universal Robots recommends ordering new parts from the Universal

Robot distributor where the robot was originally purchased. Alternatively, parts can be ordered from the nearest distributor, details of which can be obtained from Universal Robots official website at www.universal-robots.com

1.2. Company Details

Universal Robots A/S

Energivej 51

DK-5260 Odense Denmark

Tel.: +45 89 93 89 89

Fax: +45 38 79 89 89

1.3. Copyright and disclaimers

The information contained herein is the property of Universal Robots A/S and shall not be reproduced in whole or in part without prior written approval of Universal Robots A/S. The information herein is subject to change without notice and should not be construed as a commitment by Universal Robots A/S. This document is periodically reviewed and revised.

Universal Robots A/S assumes no responsibility for any errors or omissions in this document.

Copyright © 2009-2024 by Universal Robots A/S.

The Universal Robots logo is a registered trademark of Universal Robots A/S.

**NOTICE**

Universal Robots continues to improve reliability and performance of its products, and therefore reserves the right to upgrade the product without prior warning. Universal Robots takes care that the content of this document is precise and correct, but takes no responsibility for any errors or missing information.

**NOTICE**

Universal Robots disclaims any liability, even if all guidelines in this document are followed.

1.4. Safety Message Types

Safety messages and statements are used throughout this manual to emphasize important information. Read all messages and statements to help ensure safety and to prevent injury to personnel and product damage.

The safety message types are defined below.

**WARNING**

Indicates a hazardous situation which, if not avoided, could result in death or serious injury.

**WARNING: ELECTRICITY**

Indicates a hazardous electrical situation which, if not avoided, could result in death or serious injury.

**WARNING: HOT SURFACE**

Indicates a hazardous hot surface where injury can result from contact and non-contact proximity.

**CAUTION**

Indicates a hazardous situation which, if not avoided, could result in injury.

**GROUND**

Indicates grounding.

**PROTECTIVE GROUND**

Indicates protective grounding.

**NOTICE**

Indicates the risk damage to equipment and/or useful information that should be particularly noted.

**READ MANUAL**

Indicates more detailed information that should be consulted in the manual.

This warning draws attention to procedures which serve to prevent or remedy emergencies or malfunctions:

MANDATORY ACTION

Procedures marked with this warning must be followed exactly.

2. Handling ESD-Sensitive Parts



To prevent damage to ESD-sensitive parts i.e. Printed Circuit Board, follow the instructions below in addition to all the usual precautions, such as turning off the power before removing the circuit boards. See section [Complete Rebooting Sequence](#)



NOTICE

Be sure you have intact ESD Wristband and a spare ESD bag before replacing any ESD-sensitive parts.

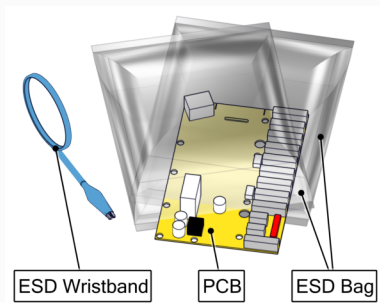

**NOTICE**

Keep the ESD-sensitive part in its original shipping container (a special "ESD bag") until the part is ready to be installed.

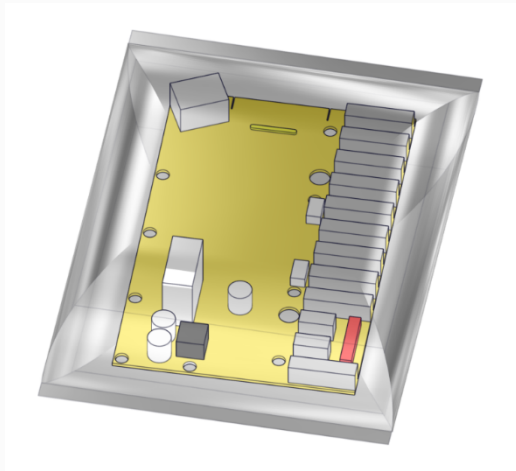
**NOTICE**

Put the ESD wristband on your wrist. Connect the wristband to the system ground point. It discharges any static electricity in your body to ground.

**NOTICE**

Replacing an ESD-sensitive part in a safe way is important to avoid damage to the part. It is important to take precautions when handling an ESD-sensitive part.

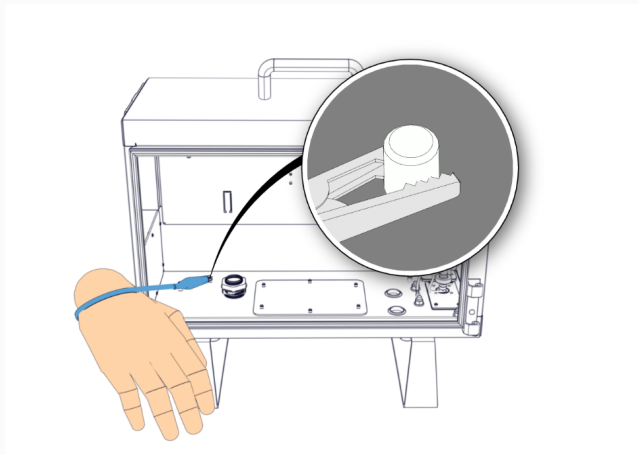
**NOTICE**

Hold the ESD-sensitive part by its edges. Do not touch its pins or hold directly on any exposed prints.

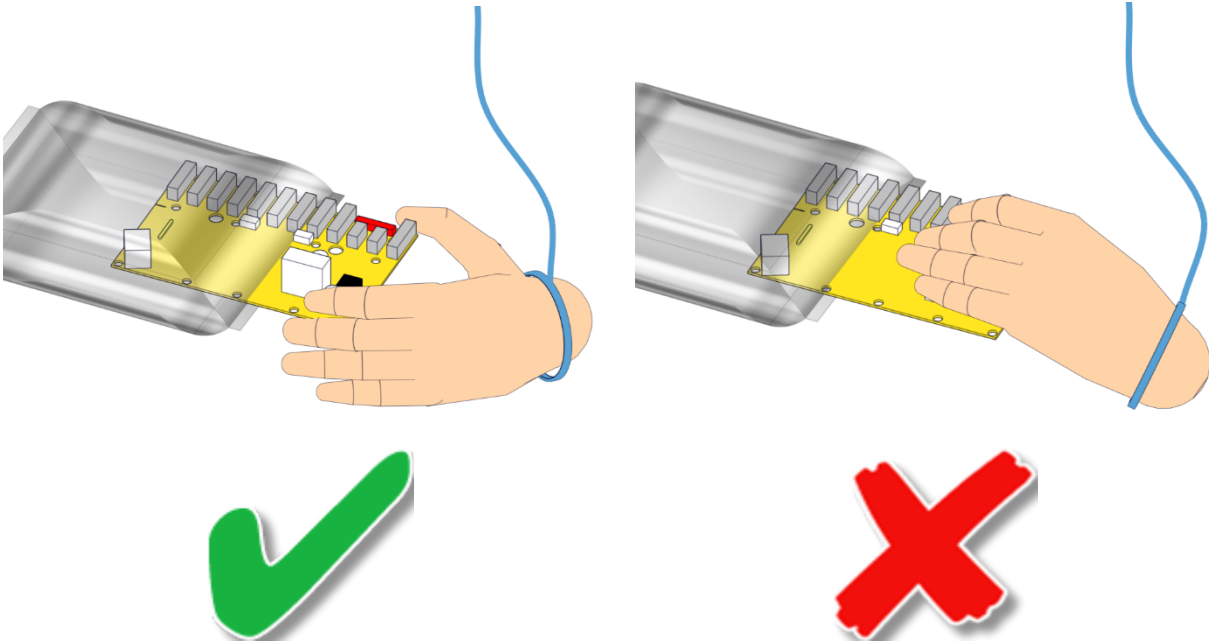
**NOTICE**

First place the OLD part in the spare ESD bag, then take out the NEW part of the ESD bag.

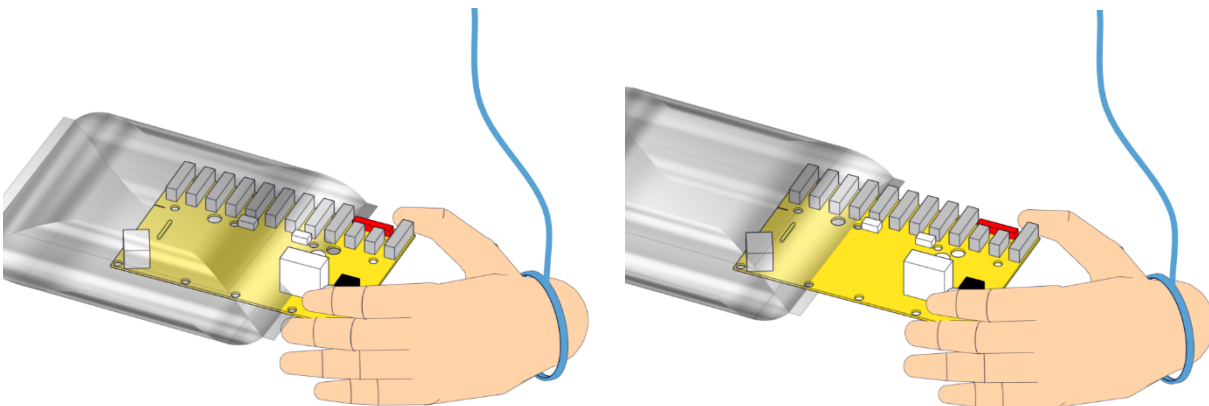
**NOTICE**

Do not place the ESD-sensitive part on nonconductive material or on metal tables/surfaces. If you must put down the ESD-sensitive part for any reason, then first place it into the ESD bag.

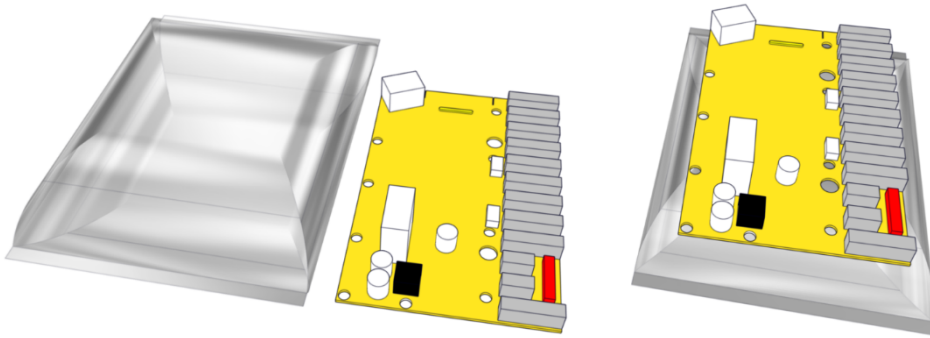

NOTICE

Machine covers and metal tables/surfaces are electrical grounds. They increase the risk of damage because they make a discharge path from your body through the ESD-sensitive part. (Large metal objects can be discharge paths without being grounded.)

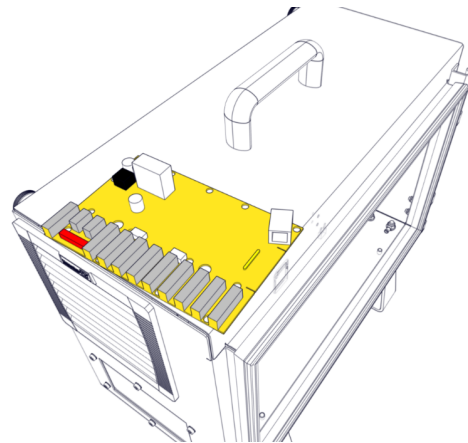
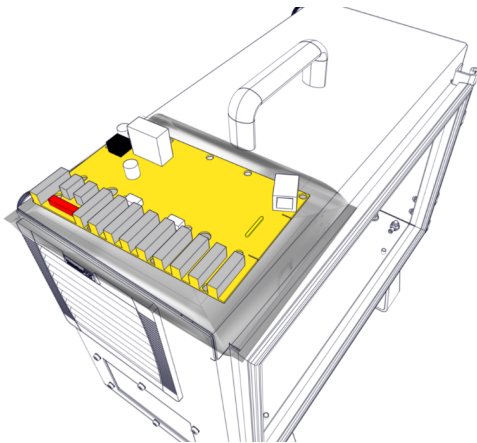

NOTICE

If passing an ESD-sensitive part to another person, ensure both are wearing ESD wristband and the ESD wristband is attached to the system grounding point.

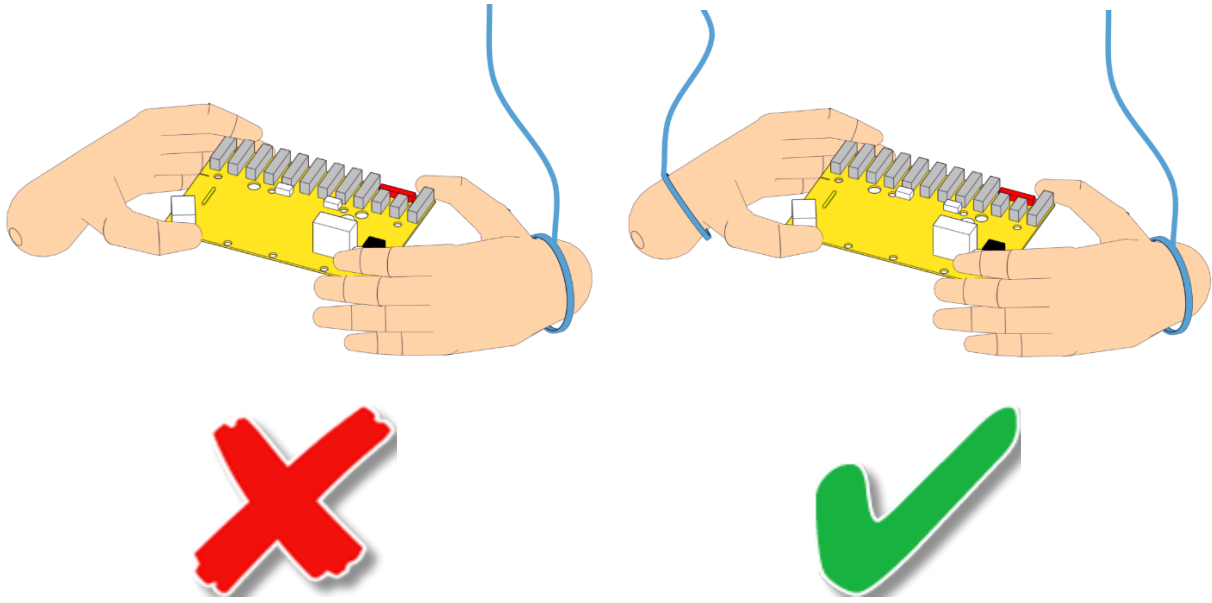

NOTICE

Be extra careful in working with ESD-sensitive parts when cold-weather and heating is used, because low humidity increases static electricity.

3. Recommended Inspection Activities

3.1. Robot Arm

3.1.1. Inspection Plan

The table below is a checklist of the type of inspections recommended by Universal Robots. Perform inspections regularly as advised in the table. Any referenced parts found to be in an unacceptable state must be rectified or replaced.

See the following sections for detailed guidance:

- [3.1.2 Visual Inspection: Robot arm below](#)
- [4.1 Pre-Use Assessment on page 16](#)
- [4.2 Robot Arm on page 18](#)

Inspection action type			Timeframe		
			Monthly	Biannually	Annually
1	Check flat rings	V		X	
2	Check robot cable	V		X	
3	Check robot cable connection	V		X	
4	Check Robot Arm mounting bolts *	F	X		
5	Check Tool mounting bolts *	F	X		
6	Round Sling	F			X

V = Visual inspection F = Functional inspection * = Must also be checked after heavy collision

3.1.2. Visual Inspection: Robot arm



NOTICE

Using compressed air to clean the robot arm can damage the robot arm components.

- Never use compressed air to clean the robot arm.

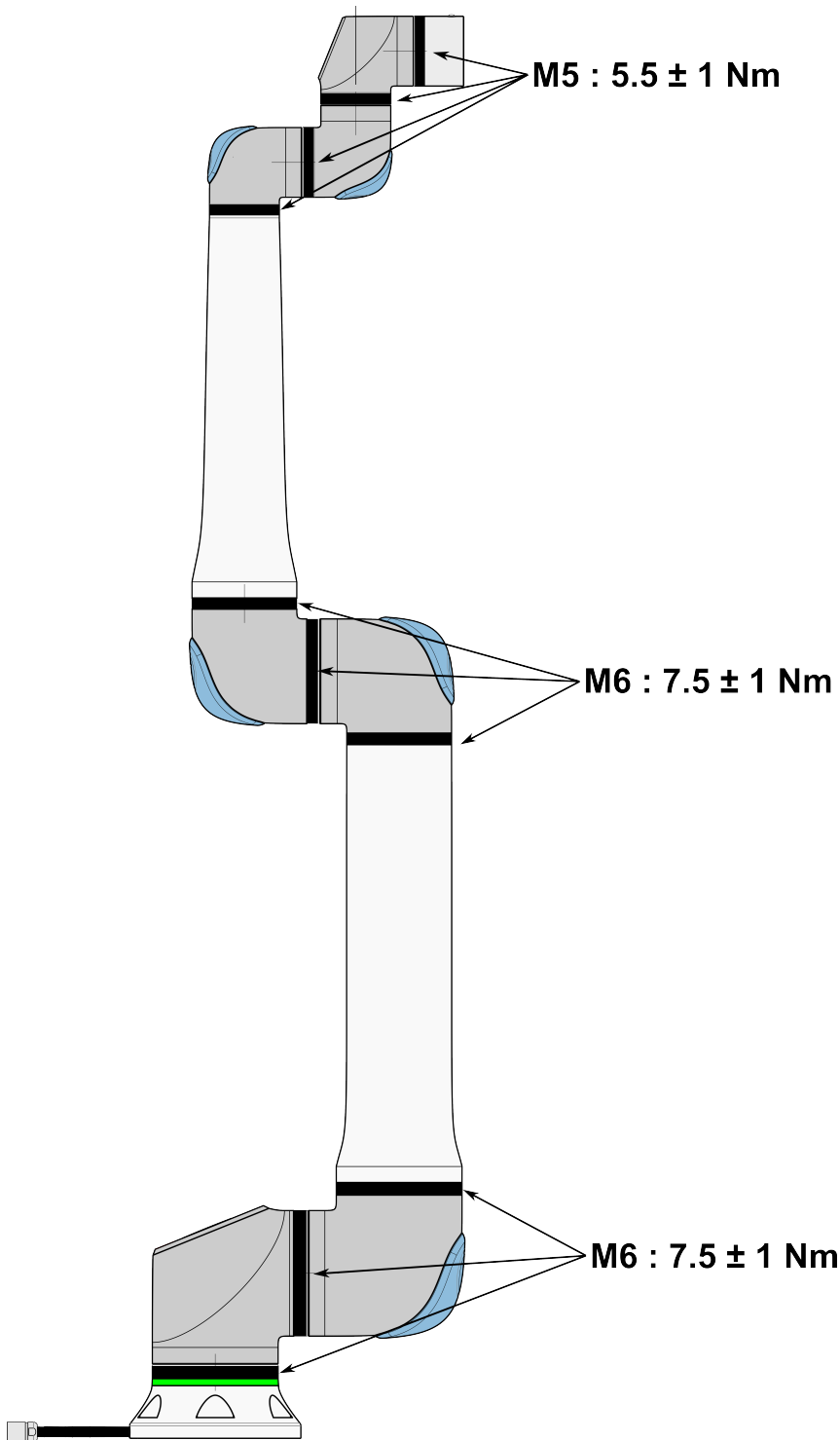

Copyright © 2009-2024 by Universal Robots A/S. All rights reserved.

1. Move the Robot Arm to ZERO position, if possible.
2. Turn off and disconnect the power cable from Control Box.
3. Inspect the cable between Control Box and Robot Arm for any damage.
4. Check the base mounting bolts are properly tightened.
5. Check the tool flange bolts are properly tightened.
6. Inspect the flat rings for wear and damage.
 - Replace the flat rings if they are worn out or damaged.

**NOTICE**

If any damage is observed on a robot within the warranty period, contact the distributor where the robot was purchased.

3.1.3. Functional Inspection

Do functional inspections to ensure the robot arm and its screws, bolts and tools are not loose.

Use a correctly calibrated torque wrench and screwdrivers specified into check the screws and bolts listed in the inspection plan.

For the robot arm mounting bolts specifications, see the Hardware Installation Manual, chapter Mechanical Interface: Mounting.

3.1.4. Cleaning your robot

Everyday cleaning

You can wipe away any dust/dirt/oil observed on the robot arm and/or Teach Pendant using a cloth and one of the following cleaning agents: Water, Isopropyl alcohol, 10% Ethanol alcohol or 10% Naphtha. In rare cases, very small amounts of grease can be visible from the joint. This does not affect the function, use, or lifetime of the joint.

Additional cleaning

Due to the added focus on cleaning your robot, Universal Robots recommends cleaning with 70% isopropyl alcohol (rubbing alcohol).

1. Wipe the robot with a hard twisted micro fiber cloth and 70% isopropyl alcohol (rubbing alcohol).
2. Let the 70% isopropyl alcohol dwell on the robot for 5 minutes, and then clean the robot using standard cleaning procedure.

DO NOT USE BLEACH. Do not use bleach in any diluted cleaning solution.

3.2. Control Box and Teach Pendant

3.2.1. Inspection Plan

The table below is a checklist of the type of inspections recommended by Universal Robots. Perform inspections regularly as advised in the table. Any referenced parts found to be in an unacceptable state must be rectified or replaced.

See the following sections for detailed guidance:

- [3.2.2 Functional and Safety Inspection on the next page](#)
- [3.1.2 Visual Inspection: Robot arm on page 9](#)
- [4.1 Pre-Use Assessment on page 16](#)
- [Control Box](#)

Inspection action type			Timeframe		
			Monthly	Biannually	Annually
1	Check Emergency stop on Teach Pendant	F	X		
2 & 3	Check the 3PE buttons by pressing them gently.	F		X	
	Check Backdrive mode	F	X		
	Check Freedrive mode	F		X	
4	Check safety inputs and outputs(if connected)	F	X		
5	Check Teach Pendant cable and connector	V		X	
6	Check and clean air filters on Control Box	V	X		
7	Check terminals in Control Box	F		X	
8 & 9	Check electrical grounding <1Ω to Control Box	F			X
	Check main power to Control Box	F			X

V = Visual inspection F = Functional inspection

3.2.2. Functional and Safety Inspection



NOTICE

Failure to test robot safety functions regularly can result in loss of functionality.

- Test the robot safety functions monthly to ensure correct function.

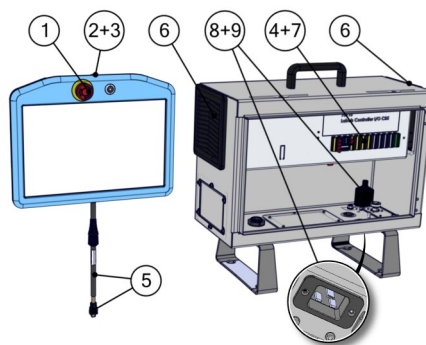

To test the Emergency Stop button on the Teach Pendant:

1. Press the Emergency Stop button on the Teach Pendant.
2. Observe the robot stops and shuts off power to the joints.
3. Power on robot again.

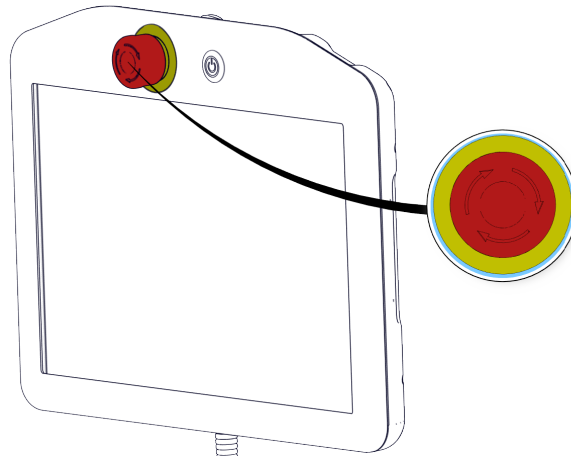

Freedrive

To test Freedrive:

1. Unmount tool/s or attachment/s or set the TCP/Payload/CoG according to tool specifications.
2. To move the robot arm in Freedrive:
 - On a 3PE Teach Pendant, rapidly light-press, release, light-press again and keep holding the 3PE button in this position.

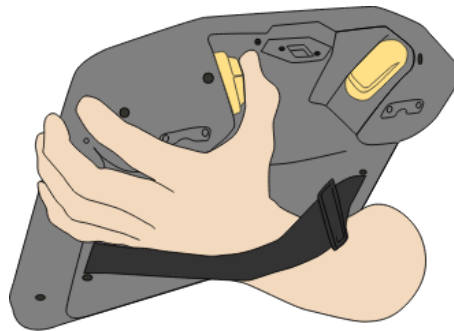

3. Pull/Push the robot to a horizontally elongated position and release.

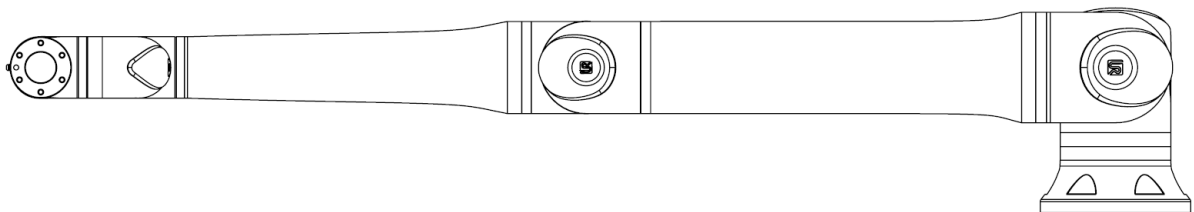

4. Verify the robot arm can maintain the position without support and without activating Freedrive.

Backdrive

If the robot arm is close to colliding with something, you can use the Backdrive function to move the robot arm to a safe position before (re)initializing it.

To test Backdrive:

1. Press ON to enable power. Status changes to *Robot Active*

Initialize

Robot Status

✓
 Power ON

✓
 Booting Complete

●
 Robot Active

●
 Brake Release

●
 Robot Operational

● **START**

● **OFF**

⚠ Warning! Stand clear of the robot when starting it!

Payload

⚠ Active Payload is used to temporarily overwrite the Installation Payload.

Active Payload

 kg

Installation Payload

0.00 kg

Exit

Robot



2. Press and hold Freedrive. Status changes to *Backdrive*

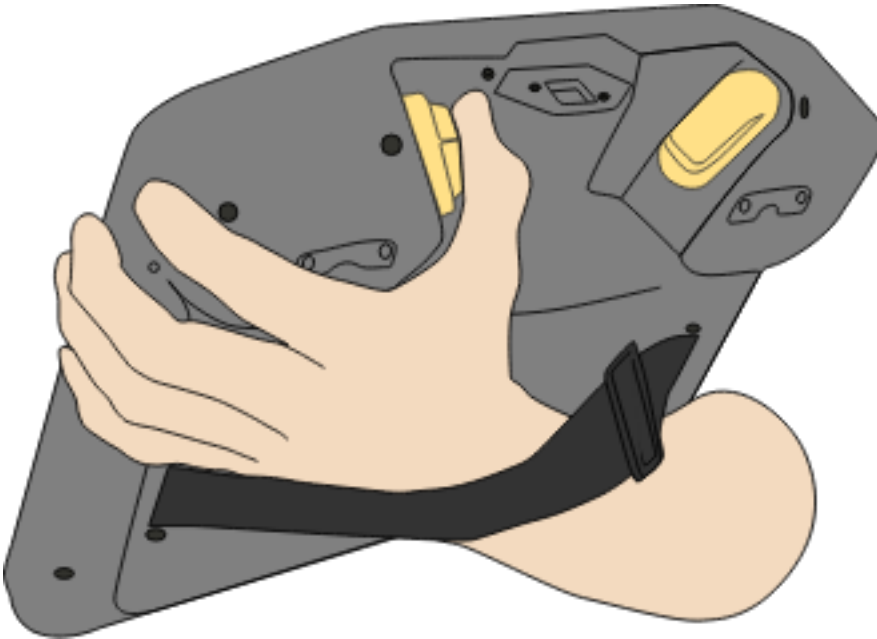

3. Move robot as in Freedrive. Joint brakes are released where needed once the Freedrive button is activated.

The robot arm is “heavy” to move around in Backdrive, so effort is required to move the joints.



NOTICE

Failure to test Backdrive on all joints can lead to loss of functionality.

- You must test Backdrive mode on all joints.

Safety settings

Verify the robot safety settings comply with the robot installation risk assessment.

Additional safety inputs and outputs are still functioning

3. Recommended Inspection Activities

Check which safety inputs and outputs are active and that they can be triggered via PolyScope or external devices.

Backup data

See section [Backup of data](#)

3.2.3. Visual Inspection: Control Box

1. Disconnect the power cable from Control Box.
2. Check the Control Board terminals are properly inserted. Do not ignore loose wires.
3. Check for any dirt/dust inside Control Box. Clean with ESD vacuum cleaner if needed.



NOTICE

Using compressed air to clean the Control Box can cause damage to the Control Box components.

- Never use compressed air to clean the Control Box.

3.2.4. Cleaning

To clean the Teach Pendant touch screen

Use a mild, industrial cleaning agent without thinning agents or any aggressive additives. Do not use an abrasive material to wipe down the screen. Universal Robots does not promote a specific cleaning agent.

To clean the Control Box filters

There is a filter on either side of the Control Box.

1. Gently remove the outer plastic frame, by pulling where the red arrows are shown in the images below. The frame tilts outward.
2. Remove both filters and use low pressure air to clean them.
If necessary, replace filters.

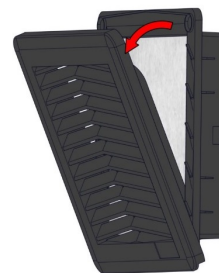
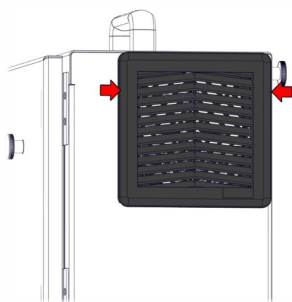

4. Service and Replacement of Parts



4.1. Pre-Use Assessment

The tests and verifications, listed below, must all be conducted before using the robot for the first time or after any modifications are made.

- Verify all safety inputs and outputs are correctly connected.
- Test all connected safety inputs and outputs, including devices common to multiple machines or robots, are functioning.
- Test that emergency stop buttons and input stop the robot and engage brakes.
- Test that safeguard input stop the robot motion. If safeguard reset is configured, check that it needs to be activated before motion can be resumed.
- Examine the initialization screen to test that reduced mode can switch the safety mode to reduced mode.
- Test that the operational mode switches the operational mode, see icon in top right corner of user interface.
- Test that the 3-position enabling device must be pressed to enable motion in manual mode and that the robot is under reduced speed control.
- Test that System Emergency Stop outputs are actually capable of bringing the whole system to a safe state.
- Test that the system connected to Robot Moving output, Robot Not Stopping output, Reduced Mode output, or Not Reduced Mode output can actually detect the output changes

Read Section 9 to learn how to pack down and ship the robot and/or spare parts. [Packing and Shipping of Robot/Spare Parts](#)

4.1.1. Recommended Tools

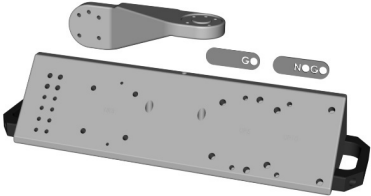
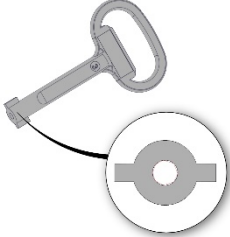
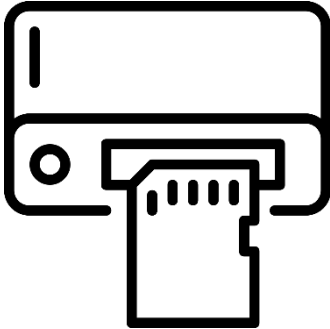
Robot Arm	Control Box	
UR20/UR30 Arm Toolkit - part no.: 200121	General Service toolkit - part no.: 200119	
		
Dual Robot Calibration tooling part no.: [TDB]	Cabinet key (double-bit key)	SD card reader
		

4.2. Robot Arm

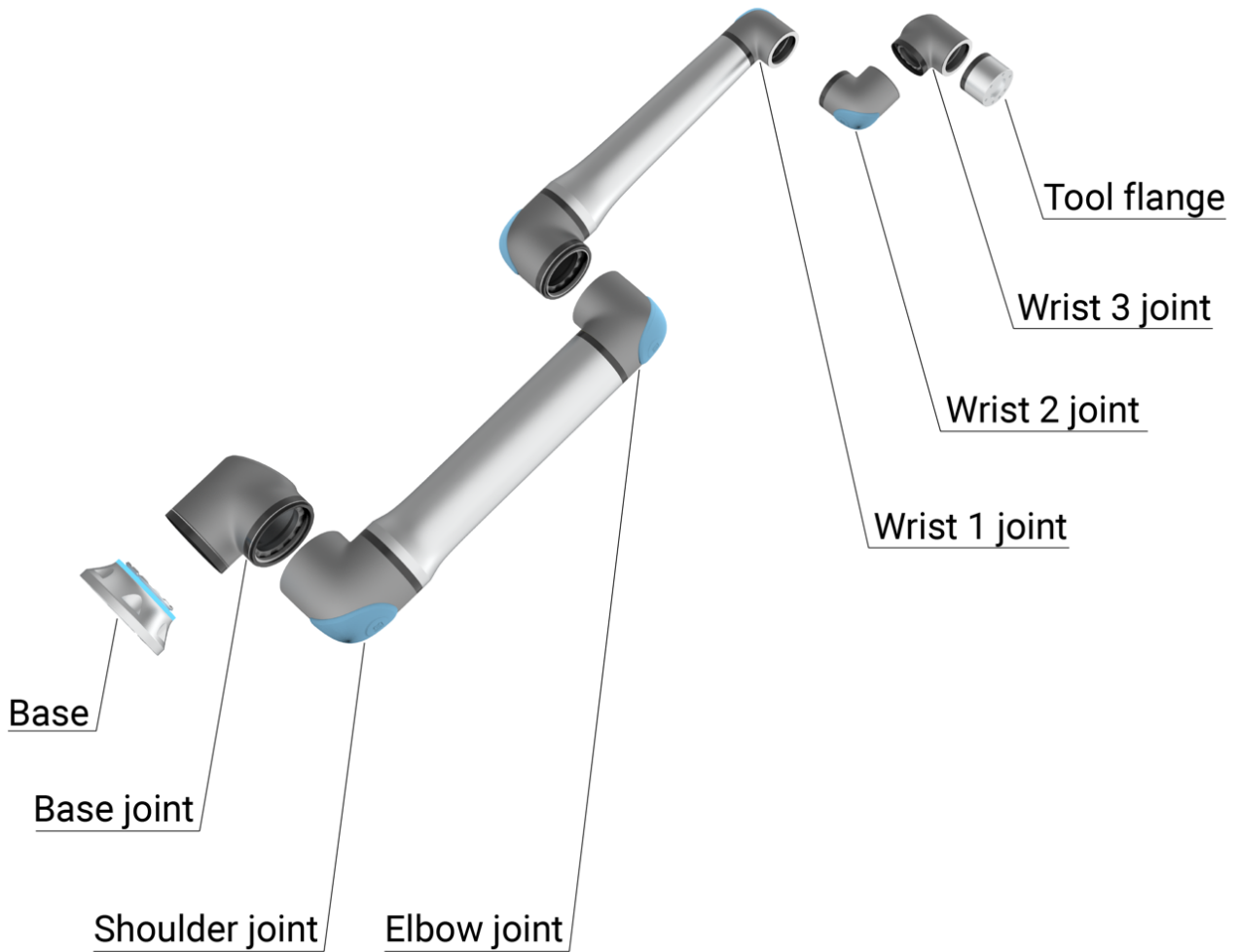

4.2.1. Joint Interchangeability

On the UR20 and UR30 robot arms only joint size 2.5 wrist 1 and wrist 2 can be switched in service situations. Every other part has their own spare part number.

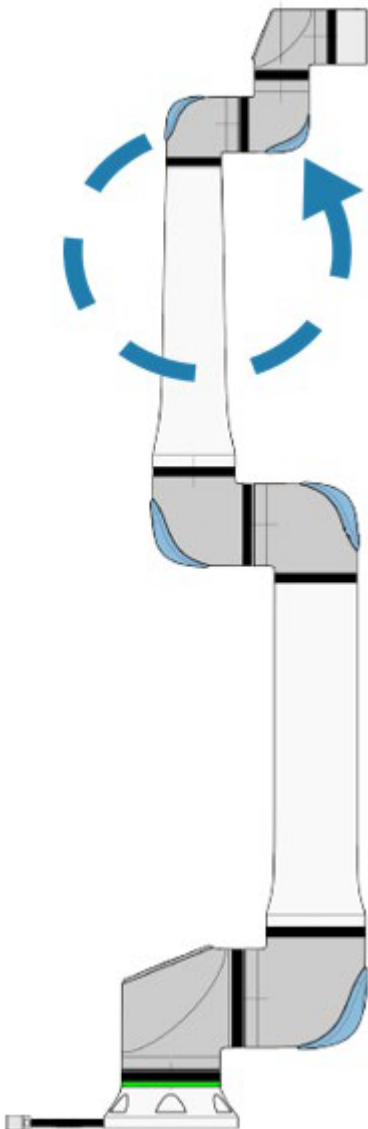

4.2.2. Connection Torque Values

The clamp connection is present between all joint assemblies.

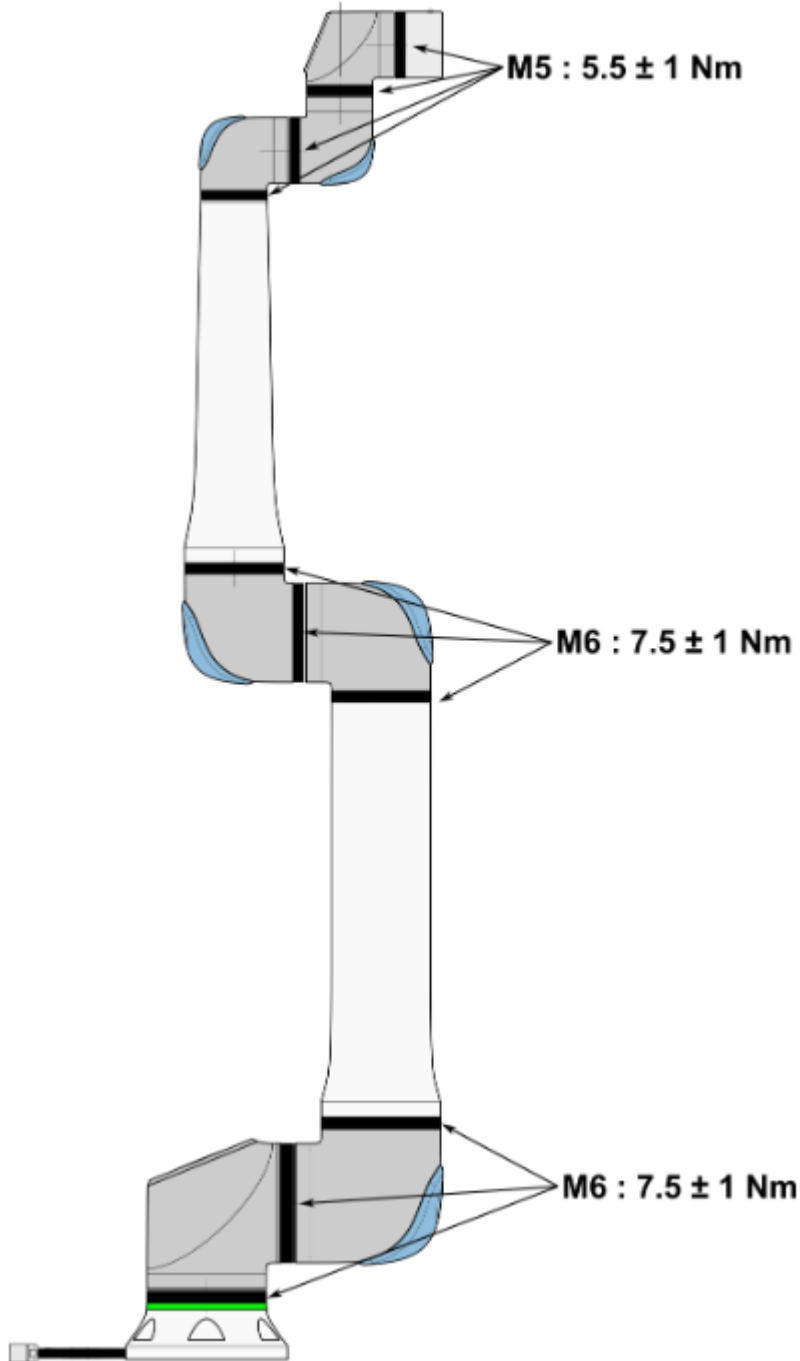

Clamp Size 2.5



Size	Thread	Head Size	Torque	Joints
2.5	M5	Hex key 4	5.5 Nm	Wrist 1 Wrist 2 Wrist 3 Tool Flange

Clamp Size 4



Size	Thread	Head Size	Torque	Joints
4	M6	Hex key 5	7.5 Nm	Elbow Joint

Clamp Size 5



Size	Thread	Head Size	Torque	Joints
------	--------	-----------	--------	--------

5	M6	Hex key 5	7.5 Nm	Base Flange Base Joint Shoulder Joint
---	----	-----------	--------	---



NOTICE

Click the torque tool a minimum of three times before use, to get the correct calibrated torque.

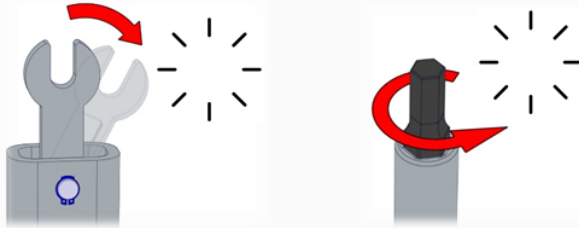

4.2.3. Clamp Connection

The following two sections describe how to disassemble and assemble a joint with a clamp connection.



NOTICE

When handling joints, consider the weight of each individual joint and observe the relevant safety rules.

Joint Size	Joint mass
Joint Size 5	15.8 Kg.
Joint Size 4	9.1 Kg.
Joint Size 2.5	2.9 Kg.

Clamp Connection: Disassembly

Description

**WARNING**

Unsupported joints can fall, or be dropped, resulting in injury.

- Support joints while clamps are being removed.

**NOTICE**

Failure to support the joint/s while clamps are removed can result in damage to equipment.

- Prevent the joint/s from falling while removing the clamp/s by doing any of the following:
 - Use something to support underneath the part that is coming off.
 - Disassemble the joint while it is laying down.
 - Support with lifting equipment.

Failure to test the old joint before replacing it, can lead to damage to property and/or equipment.

- Always perform a joint verification test before replacing a joint. See the Joint Verification section in the Service Manual for more information.

**To
Disassemble**

1. Attach the ESD wristband from the spare part package or tool kit to an electrical grounded surface.
2. Remove the black flat-ring.
You can use a pair of pointy tweezers or a small flathead screwdriver.

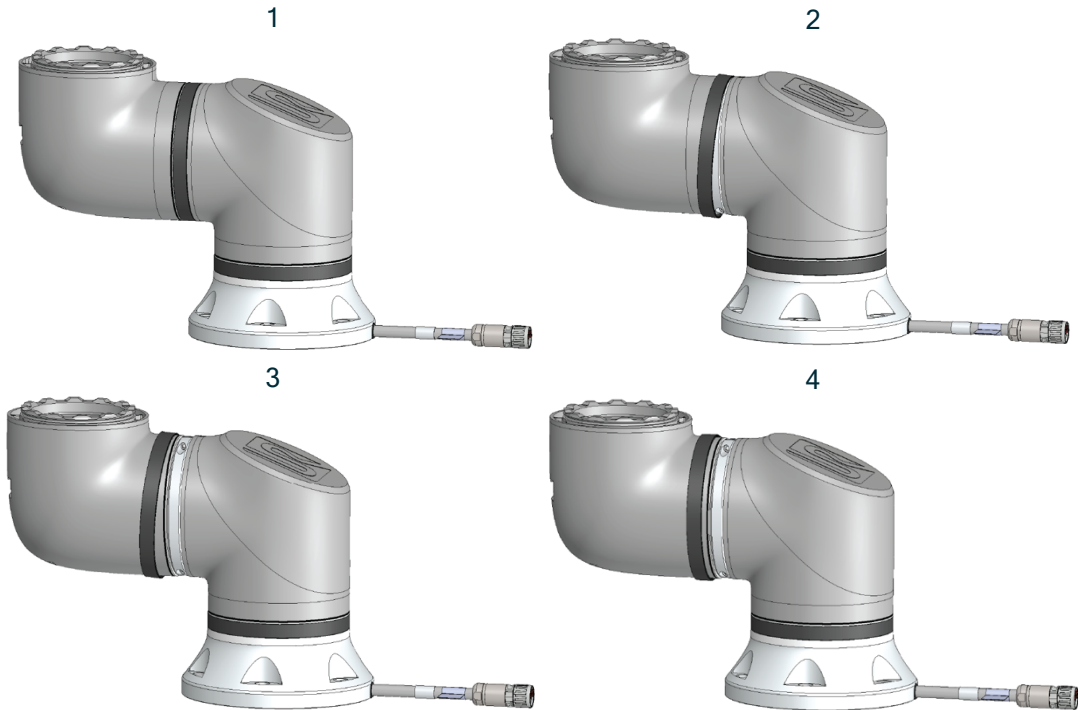

3. Remove the screws and the clamp on one side.

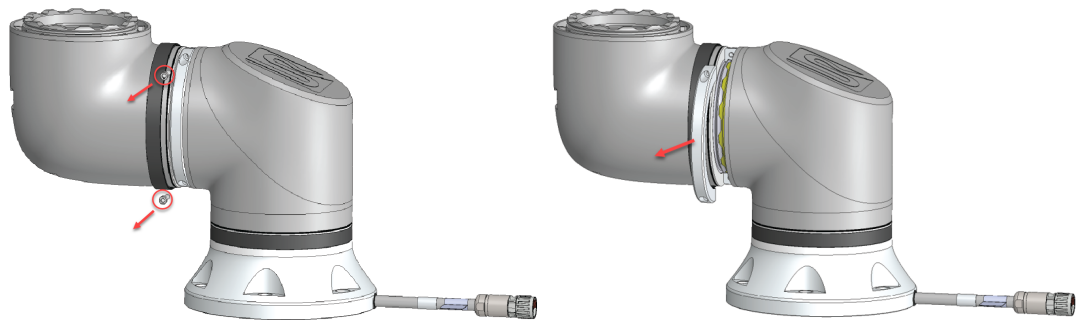

4. Support the joint as you remove the second side of the clamp.

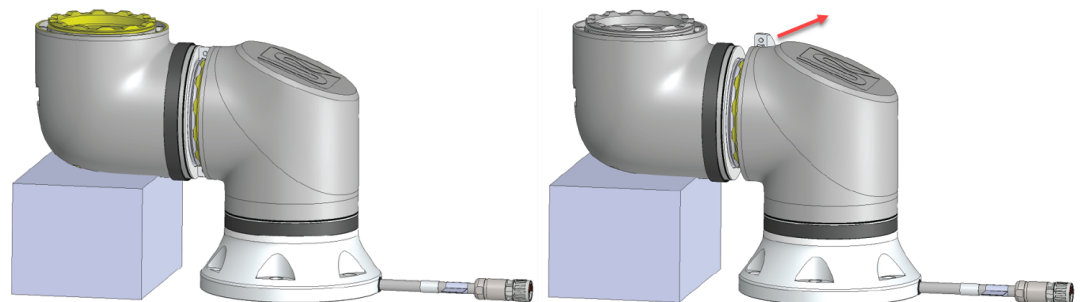

5. The joint is now loose and can be removed.

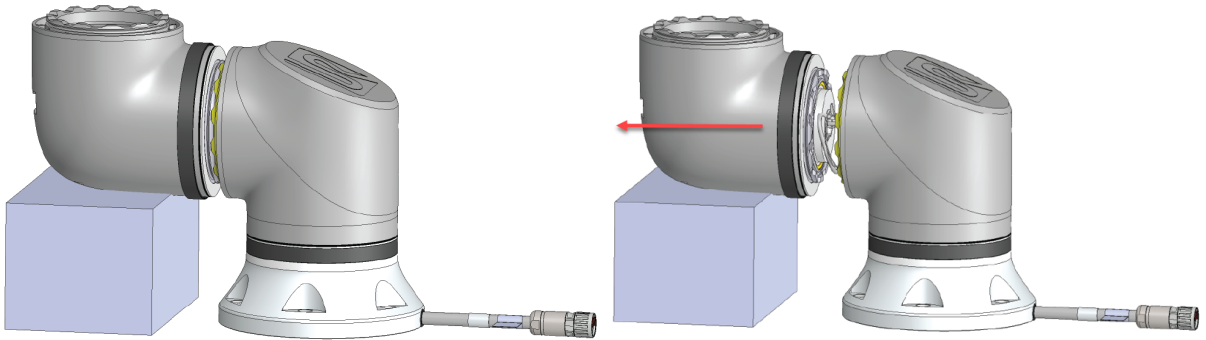

6. Gently unplug the connector from the PCB on joint.

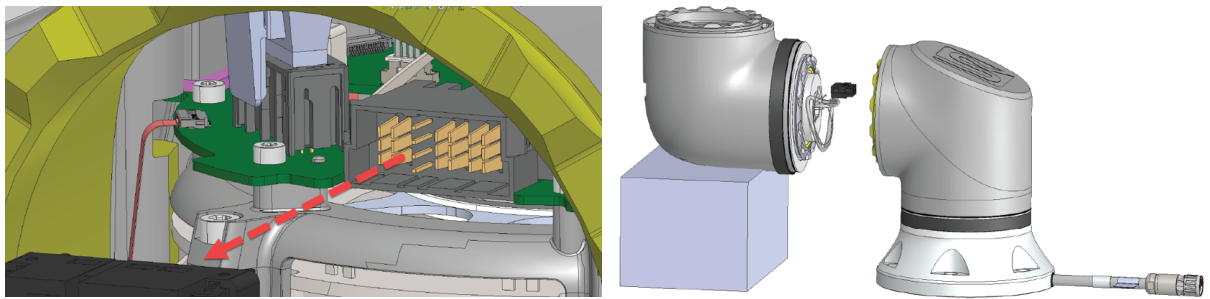

7. The joint has now been dismantled.

Clamp Connection: Assembly

Description

You can now reassemble the clamp connection with the new joint in reverse of the disassembly. However, be aware of the following before you start reassembling the clamp connection.



NOTICE

Failure to replace the black flat ring can lower the IP classification and cause damage to property and/or equipment.

- Always replace the flat ring with a new one to maintain the IP classification.
The dots must be aligned otherwise the connection cannot be made.



NOTICE

Failure to test the new joint after replacement can lead to damage to property and/or equipment.

- Always perform a joint replacement test before using a new joint. See the Joint Verification section in the Service Manual for more information.
 - Joints should be assembled in a vertical position to ensure proper mating between the joints.
-

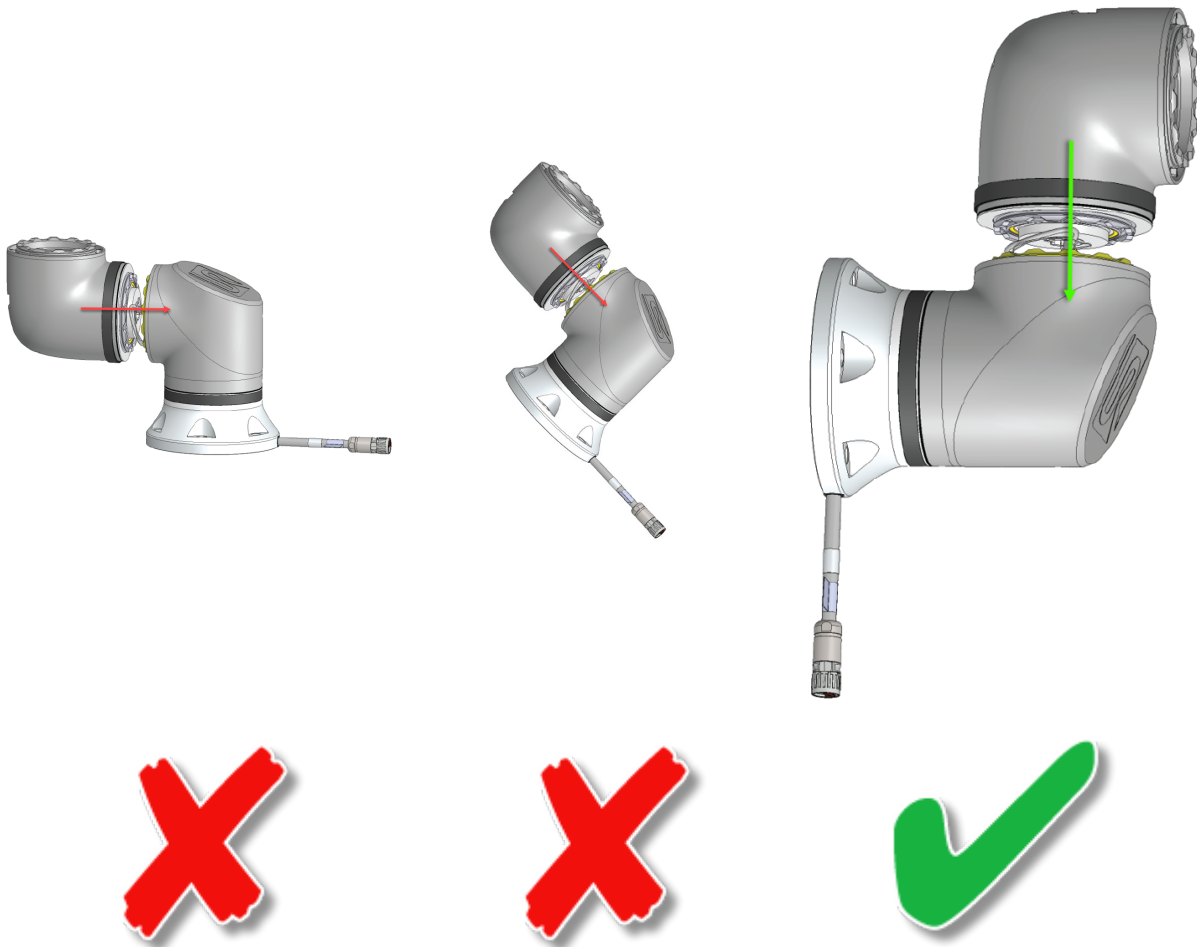

NOTICE

Improper connection between the joints can lead to damage to property and/or equipment

- Assemble the joints in a vertical position to ensure proper connection.
- Ensure the index marks are placed above each other.
- The clamps must be assembled at the index marks as illustrated below.

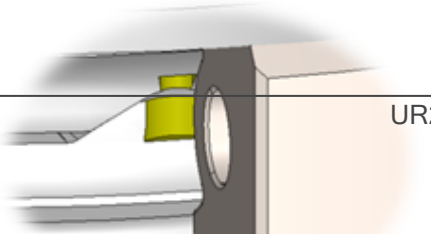
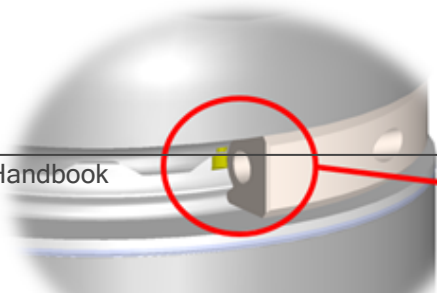



CAUTION

Ensure the screws are inserted in the correct clamp.



When tightening the clamp must be done in steps. Do not exceed recommended torque.

To assemble:

1. Tighten the bolt at one side so there is a 2 mm gap between the clamp ends.
2. Tighten the bolt at the other side with half the specified moment.
3. Tighten the bolt from step 1 with full moment.
4. Tighten the bolt from step 2 with full moment.
5. Ensure same gap at both ends.

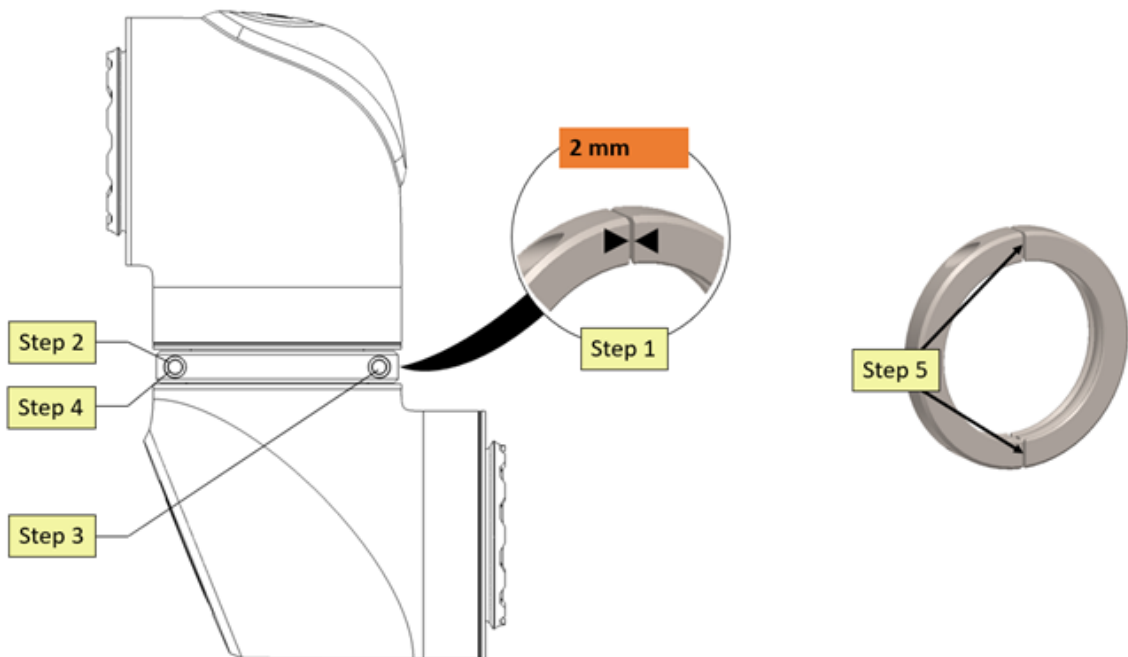

4.2.4. Tool Flange

The tool flange is a Clamp Connection and is disassembled like a joint with this connection.

See section [Clamp Connection](#)

Power and communication plug is in the same plug.

See section [Clamp Connection](#)

Power and communication plug is in the same plug.

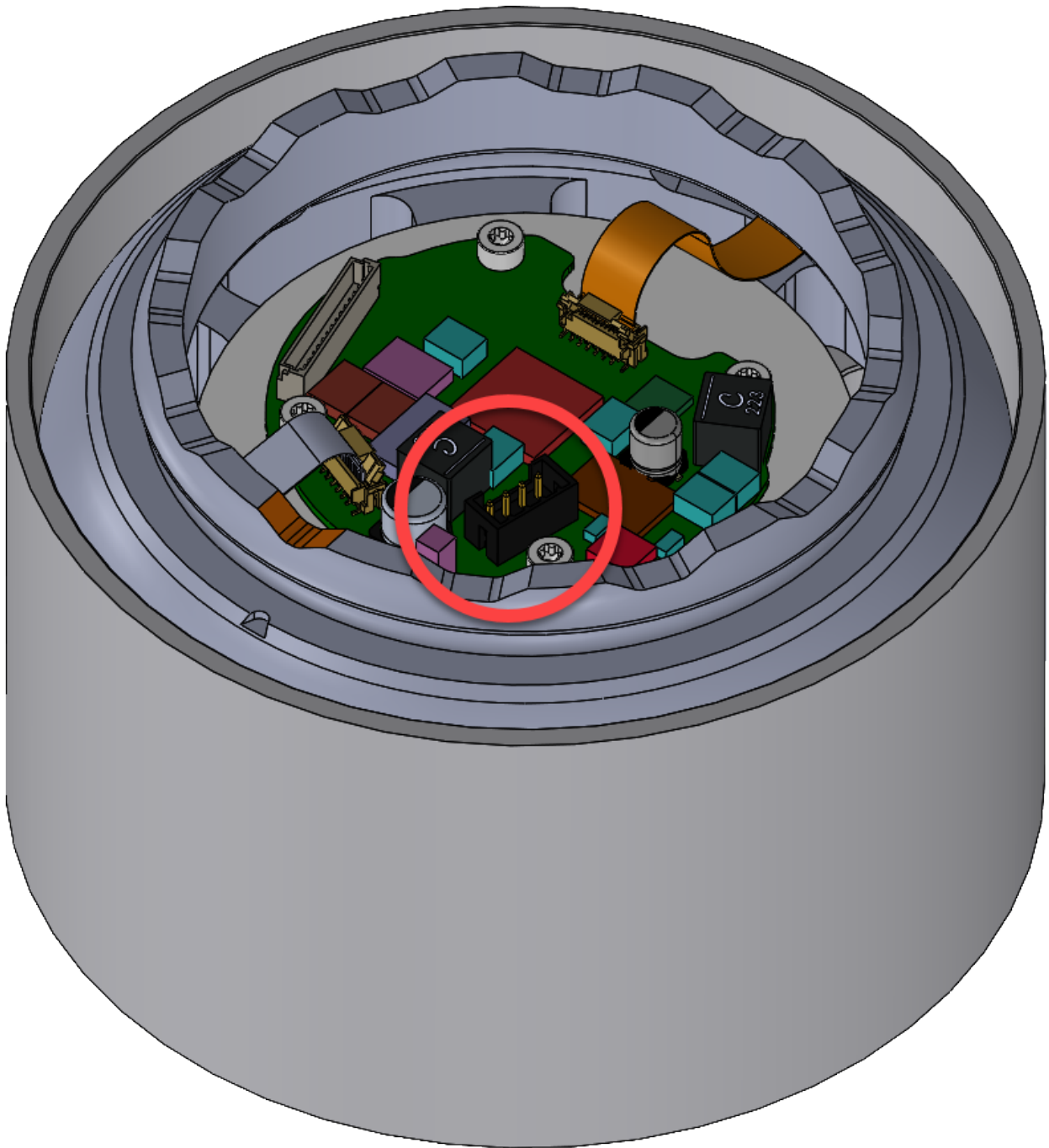

Copyright © 2009-2024 by Universal Robots A/S. All rights reserved.

4.2.5. Replacement of Trim Plates

The trim plates on a UR20 is attached with a different method than what is used on the e-Series robots. By applying pressure correctly on the trim plate, it is possible to remove them without any tools.

Dismounting Trim Plates

By pushing the front of the cover you compress the spring so the hooks can be disengaged

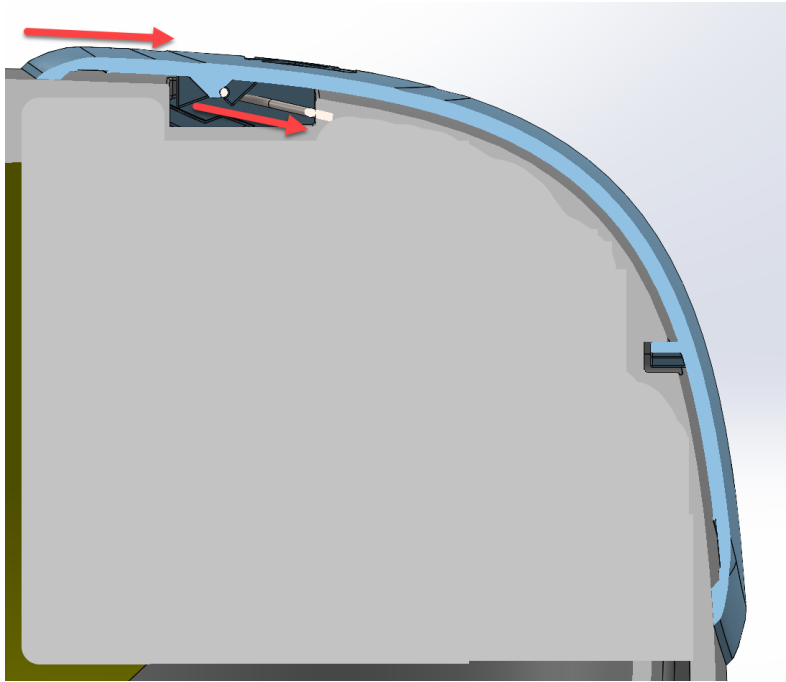

Mounting Trim Plates

By pushing the front of the cover you compress the spring so the hooks can be engaged.

The force of the spring will keep the cover in place.

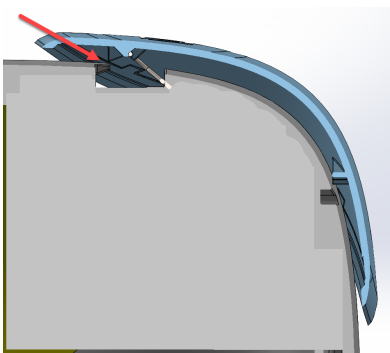

Compress the spring by applying pressure in the direction of the arrow.

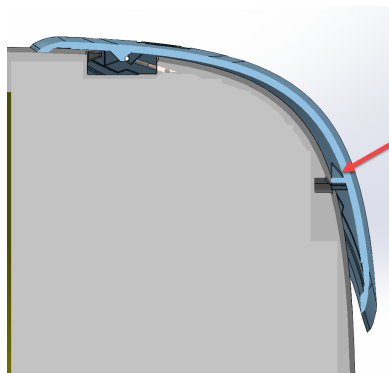

When the spring is compressed the hook can catch the housing.

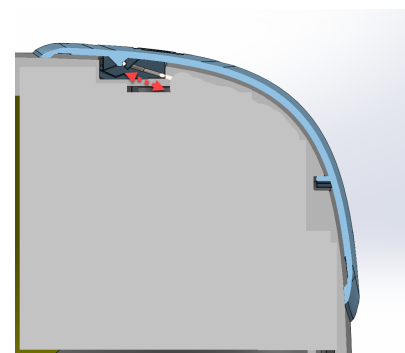

The force of the spring will keep the cover in place.

4.2.6. Joint Verification

A replacement joint needs to be verified by the controller to be assigned the correct ID. The steps below appear automatically when the robot arm is powered on for the first time.



NOTICE

Failure to test the joint before replacing it, can lead to damage to property and/or equipment

- Always perform a joint replacement test before using a new joint. See the [4.2.6 Joint Verification](#) above section for more information.

To verify joint replacement:

1. Go to Initialize screen and tap **ON**.

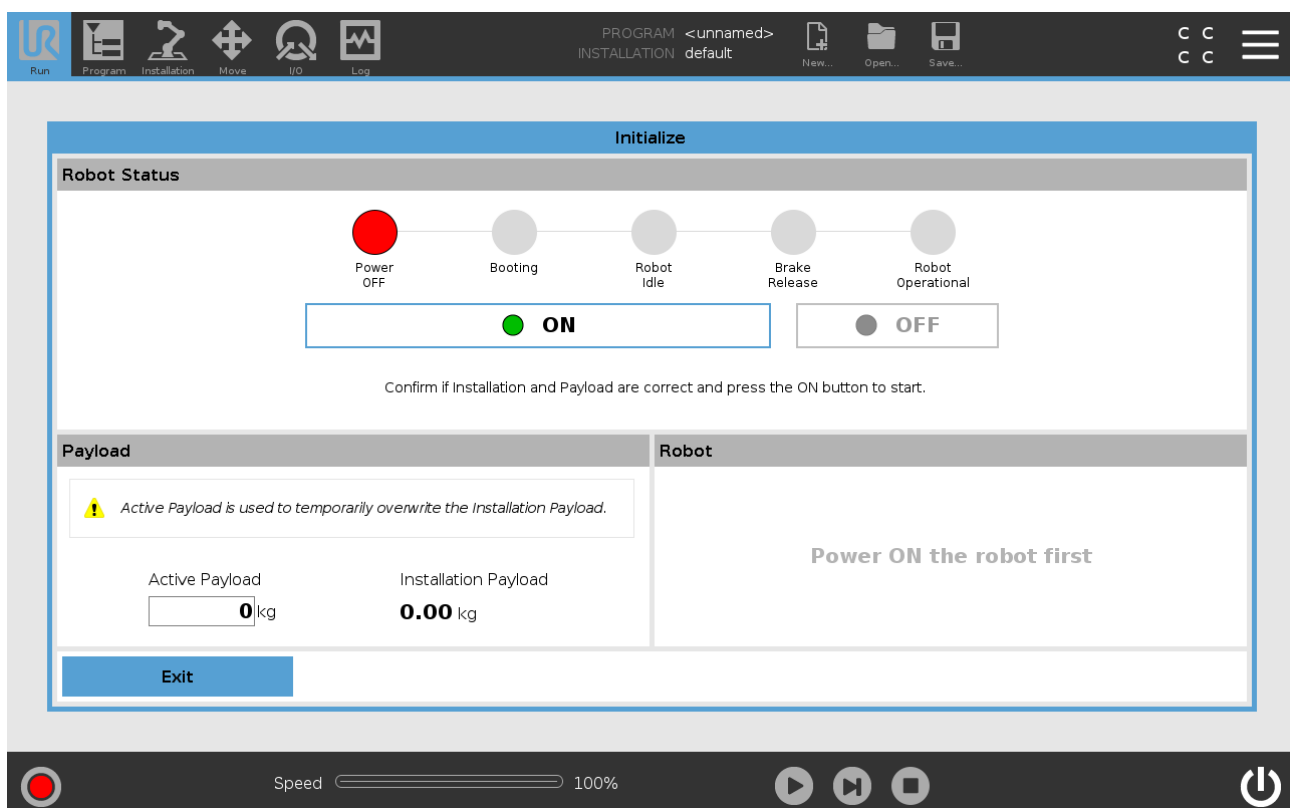

2. A popup displays the need for joint verification. Confirm the popup message by tapping **Check**

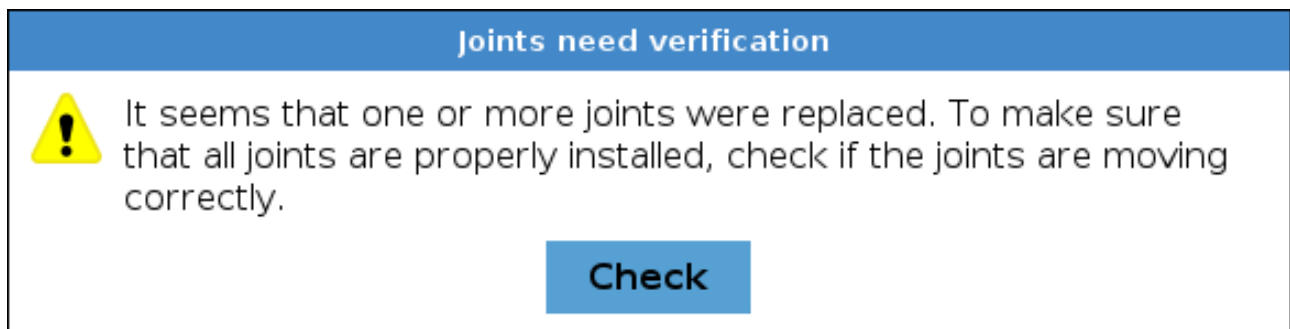

3. Tap **Test Joints** to start joint verification.

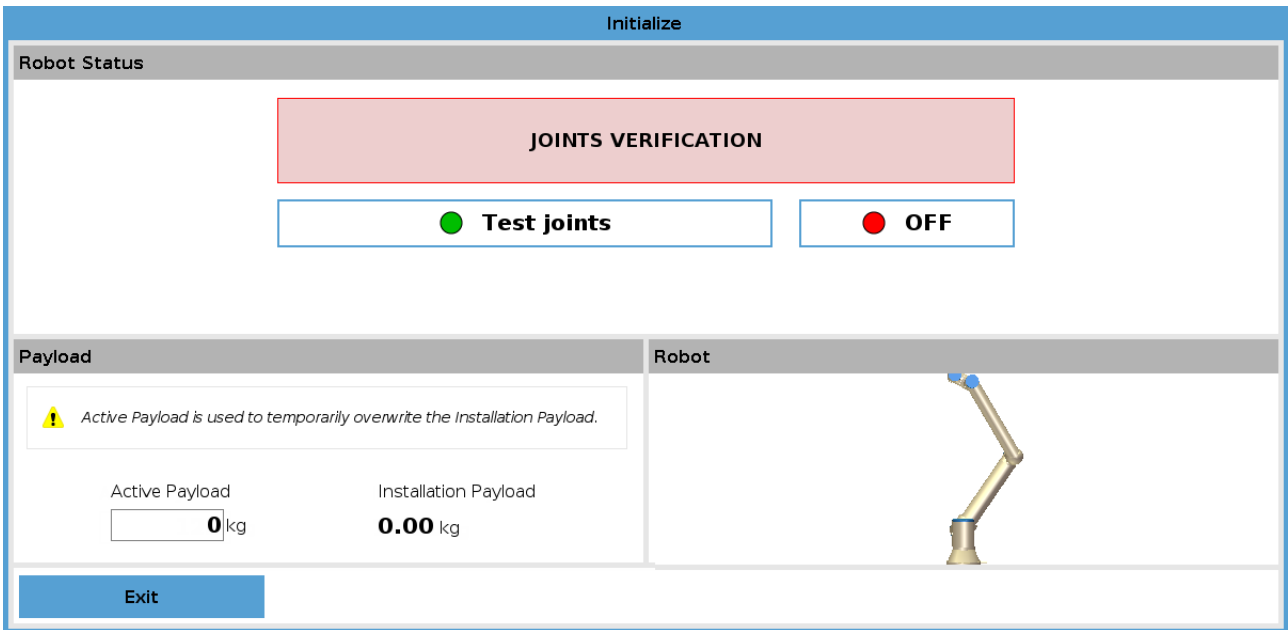

4. Move all joints with the arrows respective to each joint.

- If joints move as expected, tap **Valid** and a popup appears. Follow the popup instructions.
- If joints do not move as expected (i.e., wrong joint moves or incorrect direction), tap **Failed** and a popup appears. Follow the popup instructions.

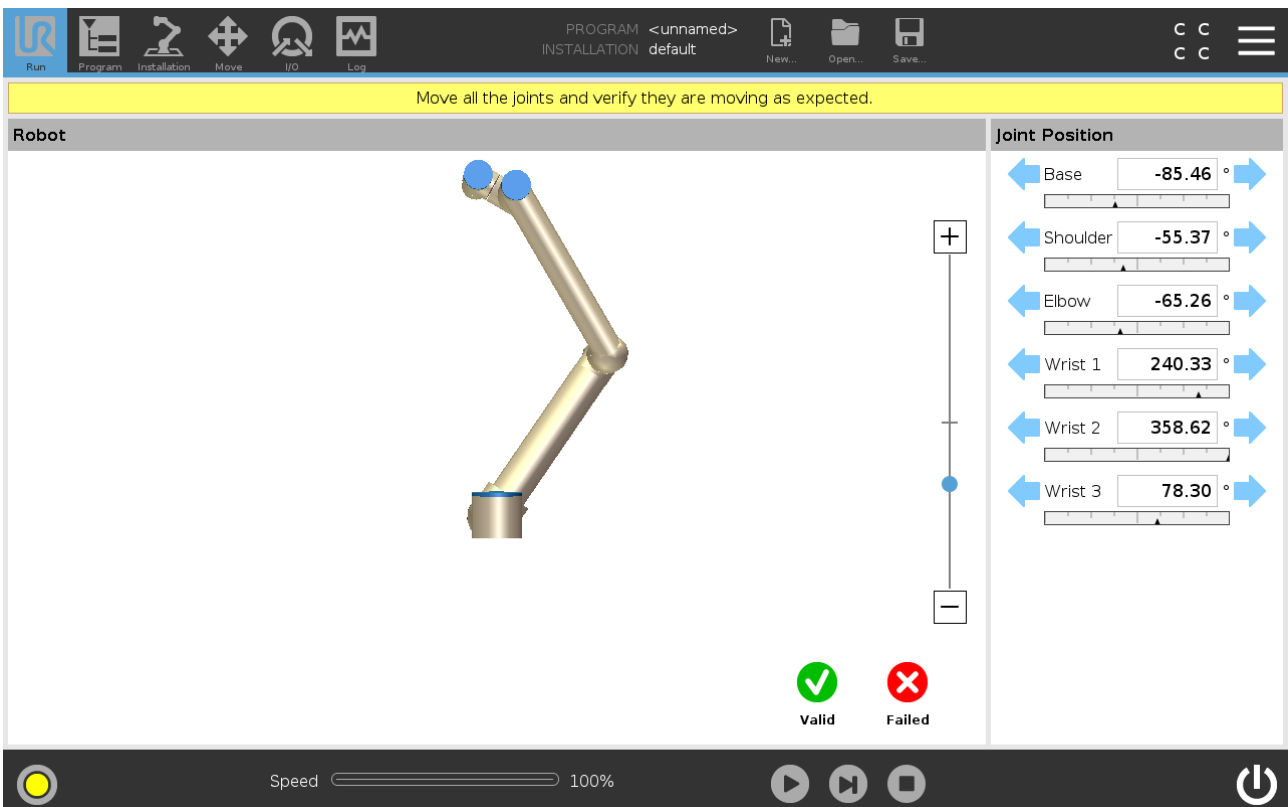

Copyright © 2009-2024 by Universal Robots A/S. All rights reserved.

4.2.7. Dual Robot Calibration

Dual Robot Calibration calibrates the robot in the full work space. Each new robot is Dual Robot Calibrated as part of final assembly.

Performing a Dual Robot Calibration after replacement of a joint allows the robot to continue in the production line without modifying waypoints in the robot program.

To perform a Dual Robot Calibration, you need:

- 2 robots (same size and same generation)
- Dual Robot Calibration Tooling Complete (Part no: **TBD**)

You can download the Calibration Manual from the Universal Robots Support site www.universal-robots.com/support/

4.2.8. Program Correction by Key Waypoints

Program Correction by Key Waypoints helps adjusting programs waypoints when a program is moved from an uncalibrated robot to another. The technique can also be used to make programs work after replacements of joints.

Please refer to the Calibration Manual from the Universal Robots Support site www.universal-robots.com/support/ for detailed description on how to use this feature.



NOTICE

Program Correction by Key Waypoints does not currently support the following:

- Other types of waypoints with the exception fixed waypoints.
- Move node with Use Joint Angles selected.

The unsupported program nodes above may need to be corrected manually after the Program Correction by Key Waypoints process is complete.

4.3. Control Box

4.3.1. Dismantling the Control Box



WARNING: ELECTRICITY

Failure to completely shut down the Control Box before replacing any components can lead to serious injury due to electrical hazards.

- Before replacing ANY components inside the Control Box, you **MUST** do a complete shutdown.
- Follow the first 3 steps in section [Complete Rebooting Sequence](#)



CAUTION

Failure to exercise caution when handling ESD sensitive parts can increase the risk of injury. See section 2. [Handling ESD-Sensitive Parts](#)

- Exercise caution when handling ESD sensitive parts
- If possible, lay the Control Box on its back while working on it.

To Dismantle the Control Box:

The illustrations below can differ from actual hardware design.

1. Power off Control Box - follow step 1 to 3 in section [Complete Rebooting Sequence](#)
2. Remove all the I/O Terminals, the Fuse, SD-card and any other I/O etc. that may be connected.

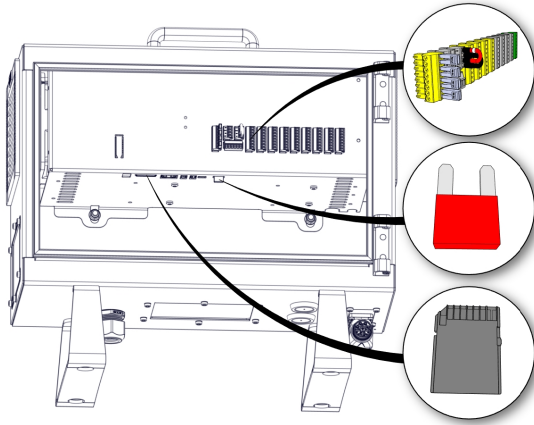

3. Remove the Teach Pendant, see Section [Replacing of Teach Pendant](#)
4. Lay the Control Box on the backside and remove the four nuts.

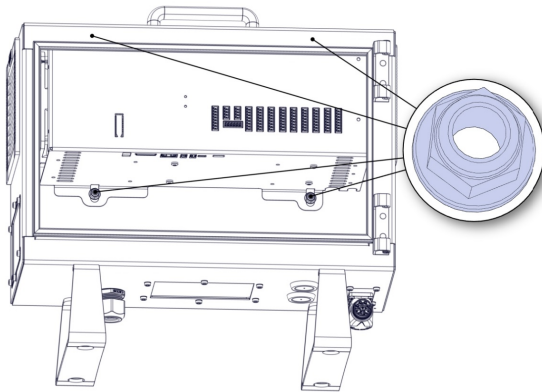

5. Take out the Control Box bracket and place it on the edge of the Control Box as shown below.

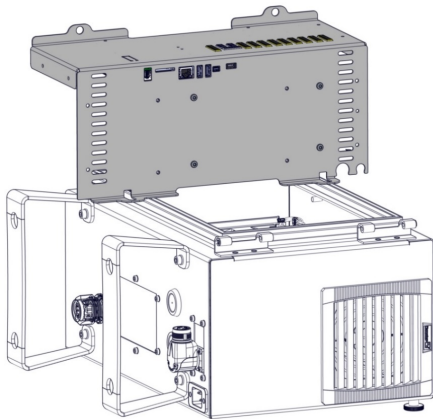

- Remove the wires connecting the Control Box bracket and the Control Box.
Take note of the connections or consult the electrical diagram in Section 7. Electrical drawings

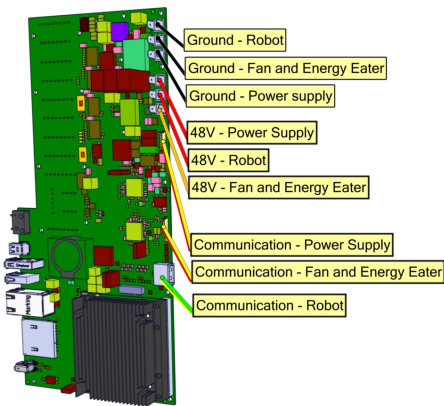
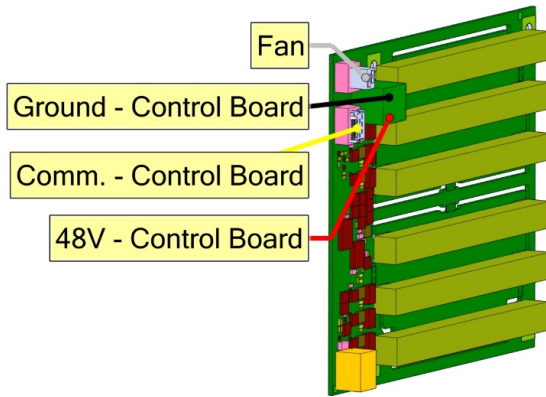

Power Supply

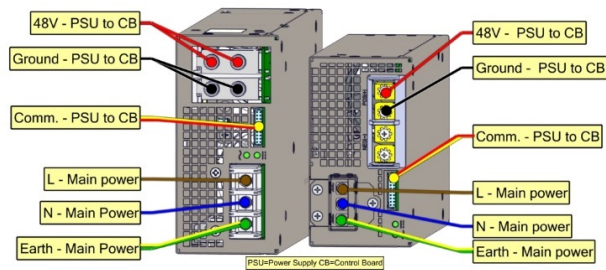

UR5e, UR10e and UR16e

UR3e

7. Remove the four screws on the bottom of the power supply, then remove the power supply.

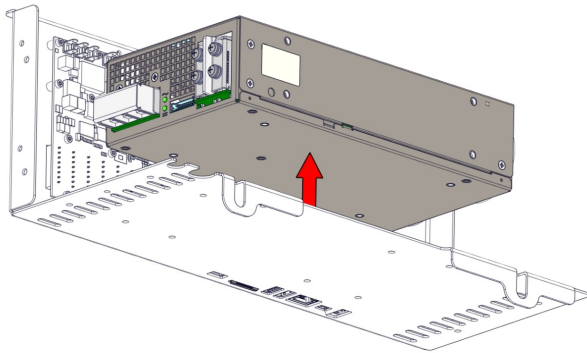
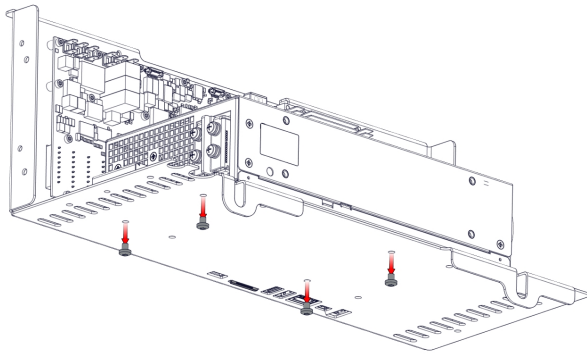

NOTICE

When assembling, do not tighten the screws using torque greater than $1.0^{+0.1}_{-0.1}$ Nm

8. Remove the twenty-two screws and remove the Control Board upward.

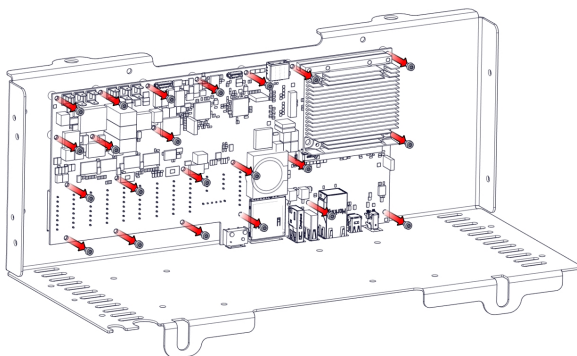

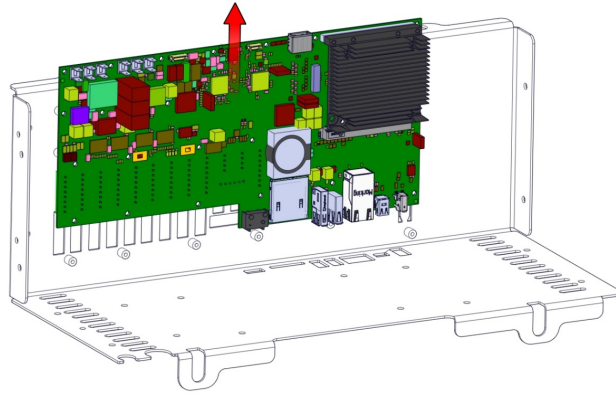

9. Removing the Energy Eater and fan assembly. Remove the four screws.

10.

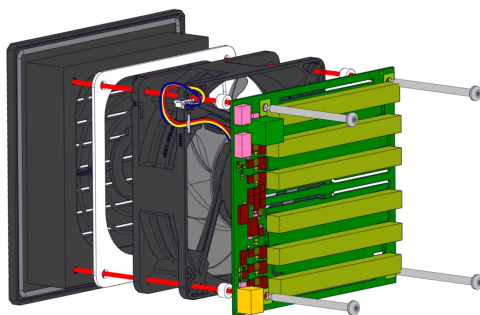
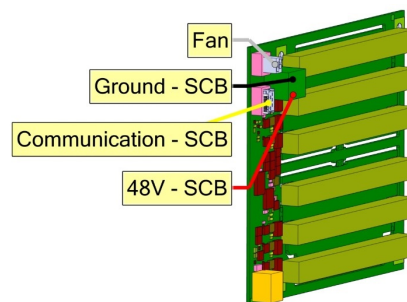
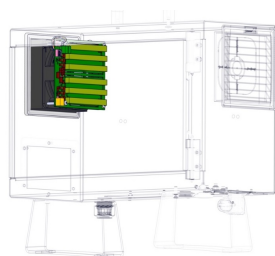

Re-assembling the Control Box is done in reverse of the steps shown above.



NOTICE

When assembling, remember to place the round spacers behind the Energy Eater board.

4.3.2. Torque Values

Torque values and notes for Control Box

Below are the torque values used in the Control Box.

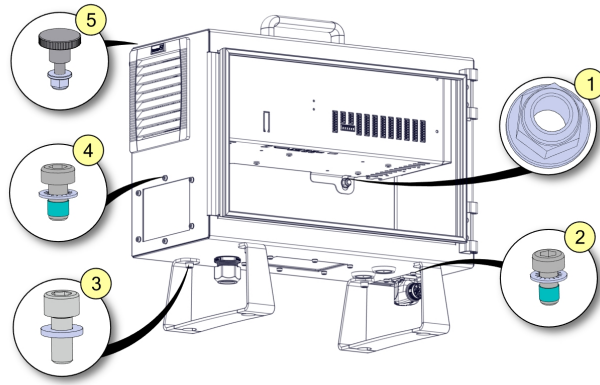

NO.	DESCRIPTION	Tool size	Torque
1	Nut for internal CB bracket	10mm	2.25Nm
2	Robot connector screw	Torx T20	1.5Nm
3	Screw for feet bracket	Hex key 5	4.0Nm
4	Screw and washer for cover plate	Torx T20	1.5Nm
5	Control Box and Teach pendant mounting nut	10mm	2.25Nm

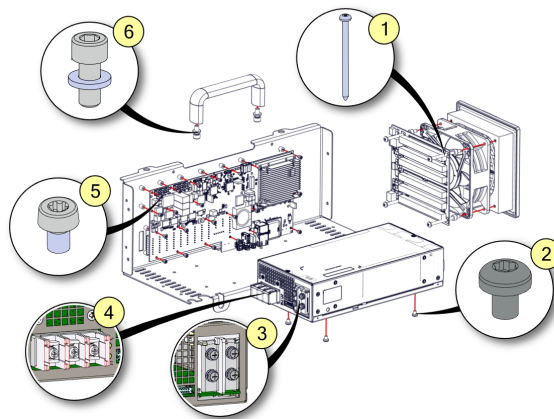

NO.	DESCRIPTION	Tool size	Torque
1	Screw for fan and energy eater assembly	Torx T20	0.6Nm
2	Screw for mounting power supply	Torx T20	1.0Nm
3	Internal power terminal screws	PZ2	1.2Nm
4	External power terminal screws	PZ2	1.2Nm
5	Control Board mounting screws	Torx T10	0.6Nm
6	Bolt for Control Box handle	Hex key 5	4.0Nm

4.3.3. Replacing the 3PE Teach Pendant

This section describes how to replace a Standard Teach Pendant with a 3PE Teach Pendant. For information on how to remove and replace a Standard Teach Pendant, see [Replacing the Teach Pendant: Standard TP](#)

WARNING

When the Teach Pendant is replaced, test the function of the 3PE buttons.



NOTICE

Replacing the Teach Pendant can result in the system reporting a fault on start-up.

- Always select the correct configuration for the type of Teach Pendant.

To remove:

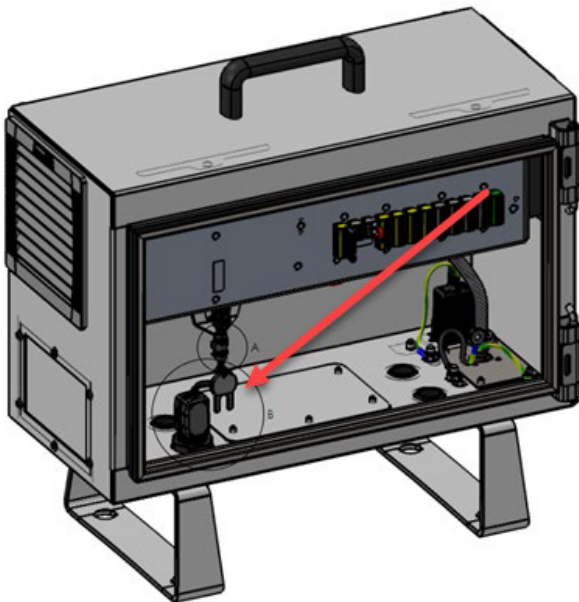
1. Power down the control box and disconnect the main power cable from the power source.
2. If mounted, remove the ferrite core with snap lock from the teach pendant cable by cutting the cable ties of key.



3. Insert the key into the ferrite core with snap lock to unlock it and remove it.





4. Remove and discard the two cable ties used for mounting the Teach Pendant cables.
5. Press in the clips on both sides of the Teach Pendant plug, as illustrated, and pull down to disconnect from the Teach Pendant port.
6. Fully open/loosen the plastic grommet at the bottom of the Control Box and remove the Teach Pendant plug and cable.
7. Gently remove the Teach Pendant cable and Teach Pendant.

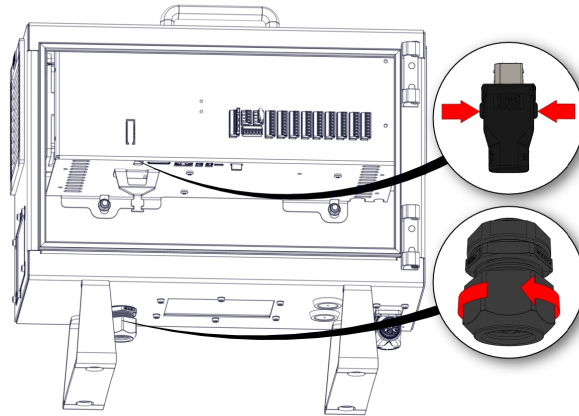

To replace:

1. Place the 3PE Teach Pendant plug and cable in through the bottom of the control box and fully close/tighten the plastic grommet.
2. Push the 3PE Teach Pendant plug into the Teach Pendant port to connect.
3. Use two new cable ties to mount the 3PE Teach Pendant cables.
4. Connect the main power cable to the power source and power on the Control Box.

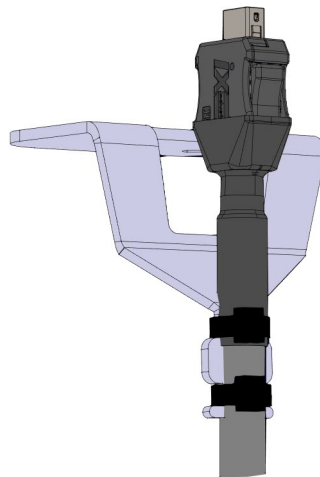

4.3.4. Replacement of Teach Pendant Cable

The teach pendant cable can be replaced with a teach pendant cable repair kit. Note: Read the disclaimer in the kit thoroughly before installing.

1. Turn the Teach Pendant around and place it carefully on something soft. Be careful not to damage the E-stop button.

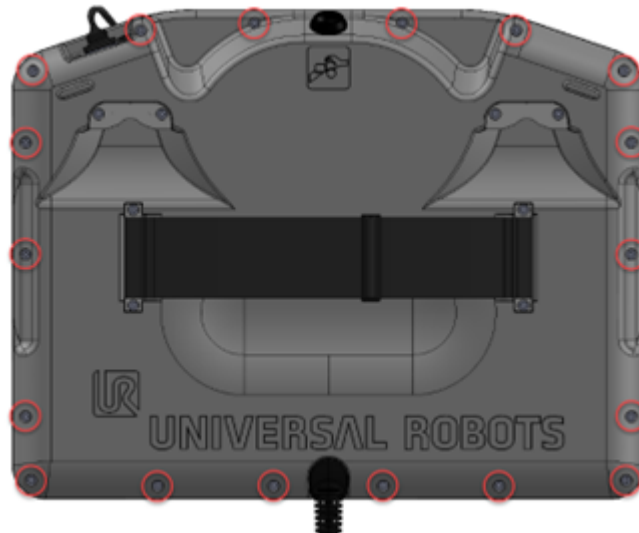

2. Remove the 18 bolts connecting the front frame to the back plate using a T8 Torx screwdriver.

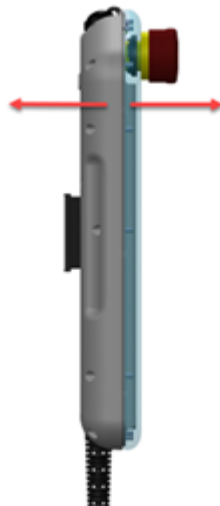

3. Pull the front frame and back plate apart. This will in some cases require some force but note that there is a cable connecting the two parts, be careful that this cable or connectors does not get damaged.

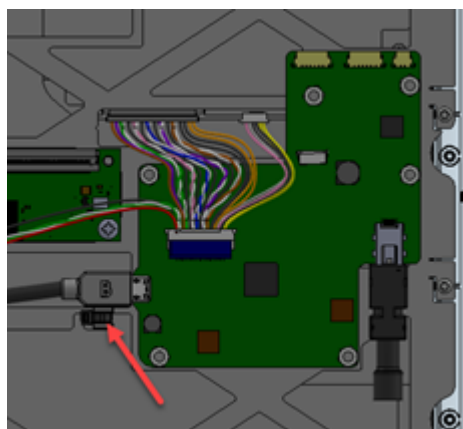

4. On the front frame, cut the cable tie and unplug the cable that are connecting the front frame and back plate.

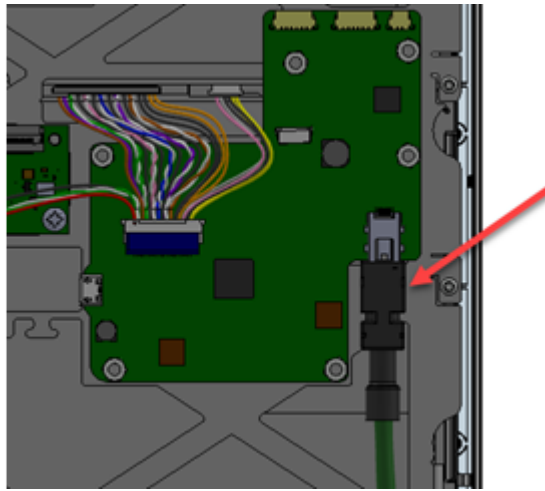

5. Unplug the Teach Pendant cable.

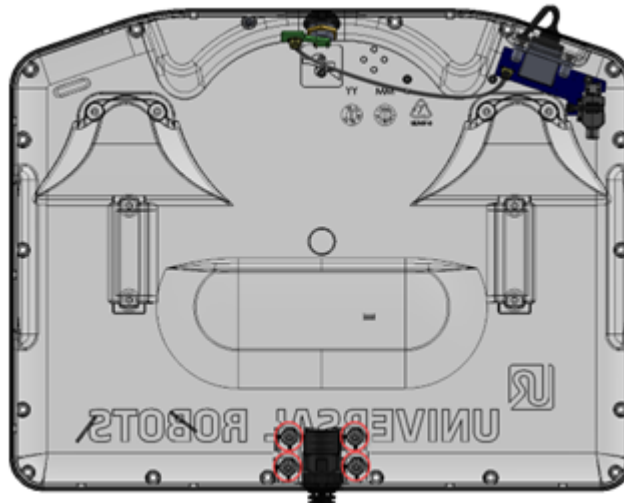

6. On the back plate remove the 4 bolts on the Teach Pendant cable bracket, using a T8 Torx screwdriver, and remove the bracket.

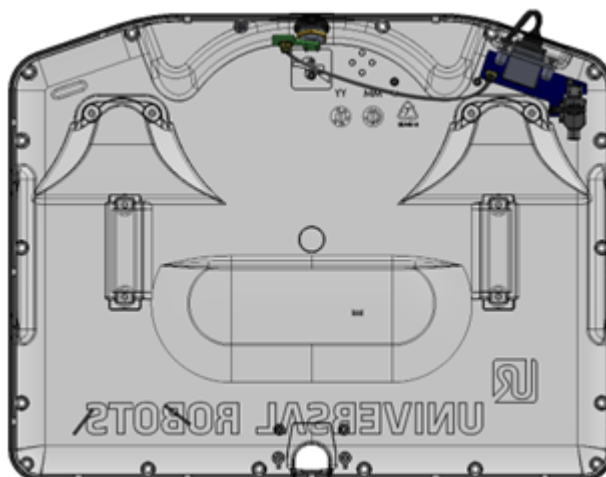

7. Teach Pendant cable can now be removed.

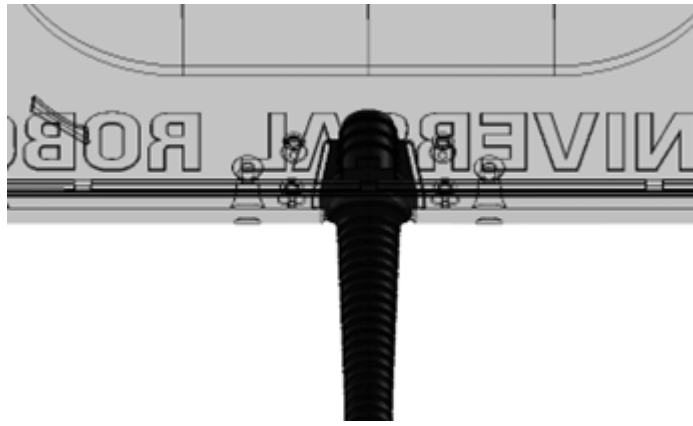

8. Find the new Teach Pendant cable from the kit. Pull it through the hole the back plate. Make sure that the rubber cable collar is mounted correctly in the hole.

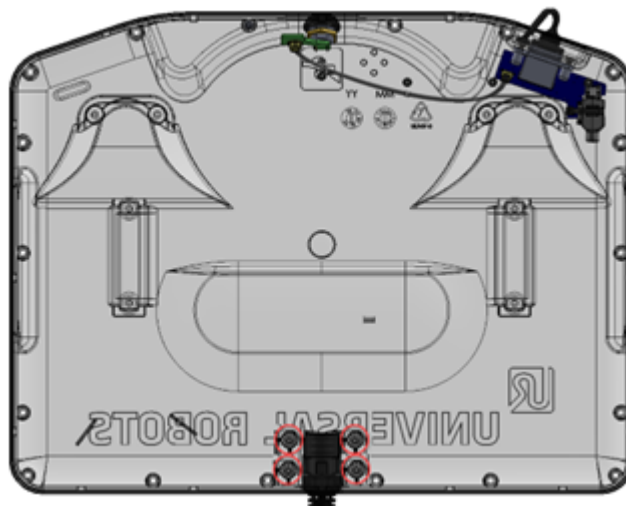

9. Mount the Teach Pendant cable bracket again and mount the 4 bolts with 0.3 Nm using a T8 Torx screwdriver.

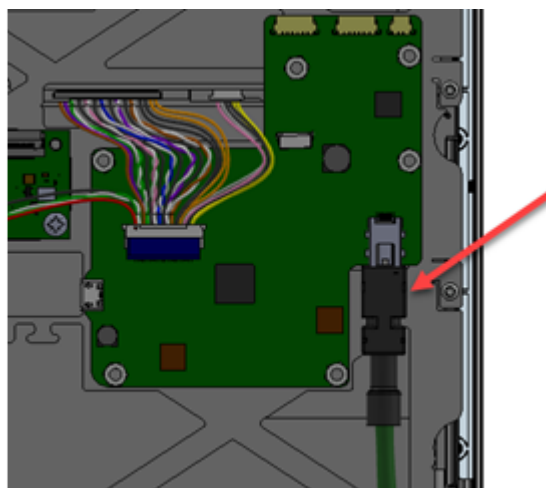

10. On the front frame connect the Teach Pendant cable on the PCB connector again.

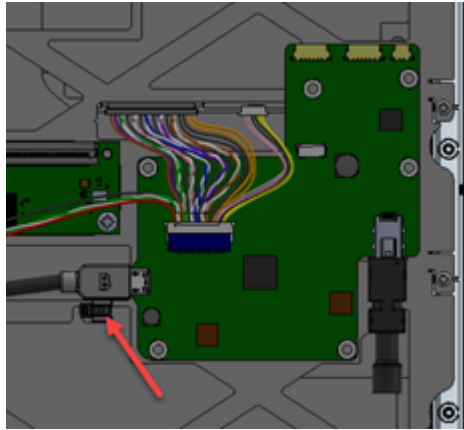

11. Connect the cable between the front frame and back plate on the other PCB and mount the new cable tie from the kit.

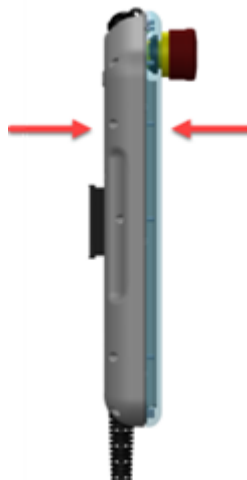

12. Connect the front frame and back plate again.

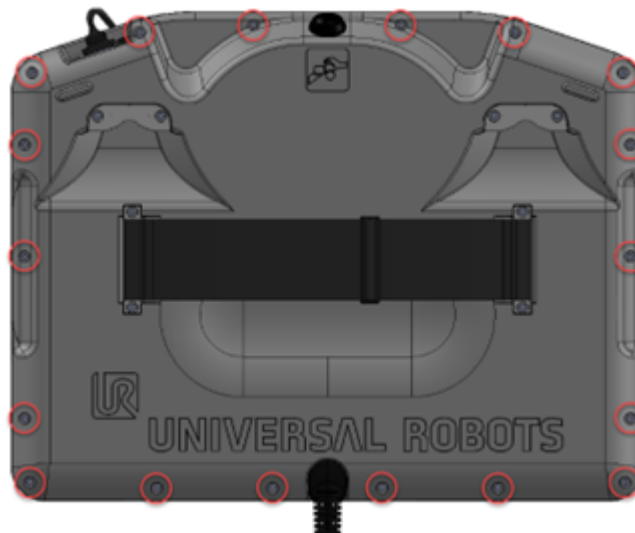

13. Mount the 18 bolts connecting the front frame to the back plate with 0.3 Nm, using a T8 Torx screwdriver.

5. Software

Under 5.1.3: Universal Robots do not recommend or support downgrading of Polyscope software. Downgrading can in some cases break hardware compatibility or corrupt program functionality. In doubt reach out to Universal Robots.

5.1. Long Term Support

Since PolyScope software release 5.12 Universal Robots has introduced a long-term support strategy to ensure hardware compatibility with requiring updating to latest software version. The long-term supported software version does not introduce new features but will ensure hardware compatibility due to product changes. Please note that it is the major software release that will be long-term supported. The minor releases are continuously updated (e.g. 5.12.x is long-term supported, the minor releases, stated with x, will be subject for changes)

See which PolyScope version is currently long-term supported on Universal Robot's website:
<https://www.universal-robots.com/support/>

5.2. Software Updates

Keeping the robot software, PolyScope, up to date is required to ensure safe operation. The latest software provides more features and a better performance.

Read the release notes for the new software to be informed about the software changes which, in some cases, are relevant to the safe operation of the robot.

In case of questions or concerns related to your application please contact your supplier for advice and assistance.



NOTICE

Powering off the Control Box during a software update can cause loss of data and malfunction.

- Do not power off the Control Box during the software update process.
- Universal Robots assumes no responsibility for failed updates caused by improper operation.



NOTICE

Updating the software can cause changes to functionality, as robot motions might change or be subjected to different restrictions.





READ MANUAL

Read these instructions and the instructions on our support website (www.universal-robots.com/support) completely prior to updating your software.

5.2.1. Update Procedure

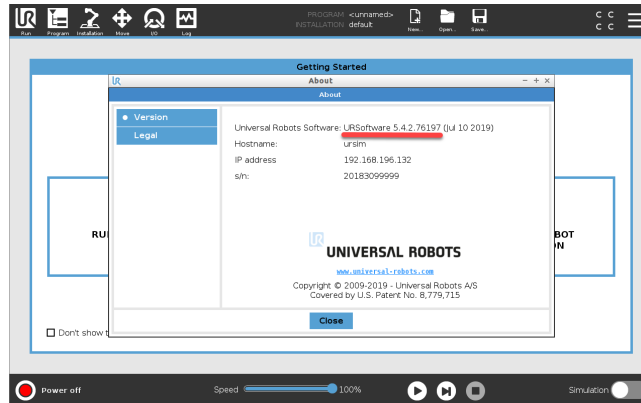
1. On your robot, go to About and check your current software version.



2. Download to your computer the software versions needed to be installed, you can download from Universal Robot's website (www.universal-robots.com/support).
3. Download the software version(s) needed to update your software and save file(s) in the root of a USB stick on your computer.
4. On the top right side of the Teach Pendant, insert the USB stick into the USB connector.
5. On teach pendant screen, press the right top corner icon  to access the settings menu.

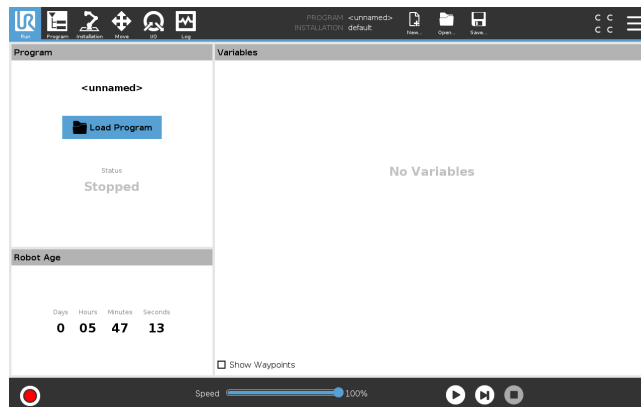

6. Press Settings to access the settings menu.

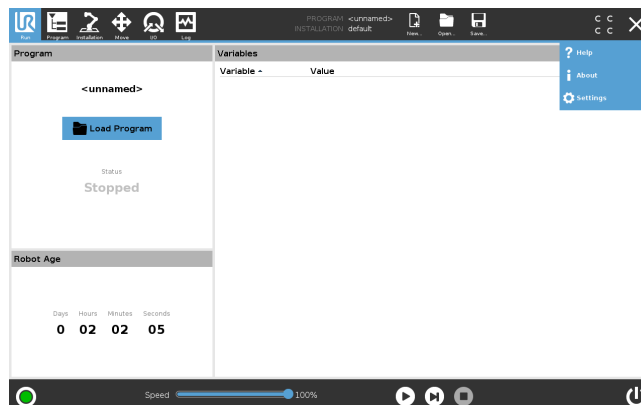

7. On the left side menu, select System.

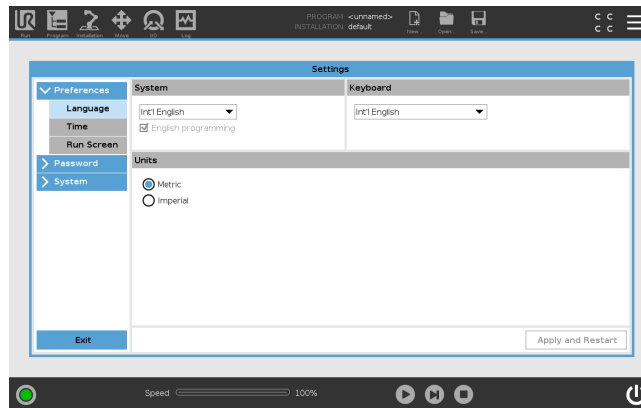

8. Press Update, then Search to locate software update on USB stick.

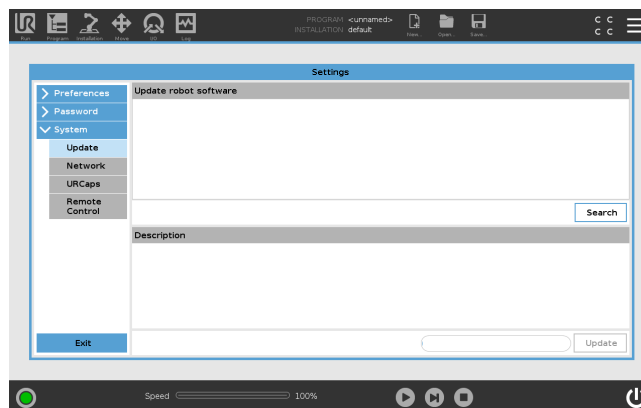

9. Select the desired software update and press Update.

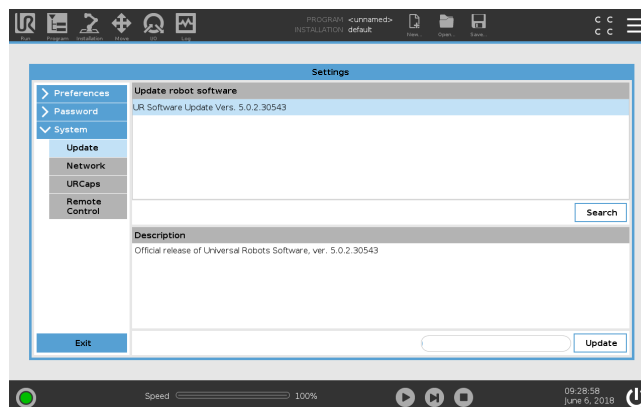

10. Press Install Software to update the software.

Copyright © 2009-2024 by Universal Robots A/S. All rights reserved.

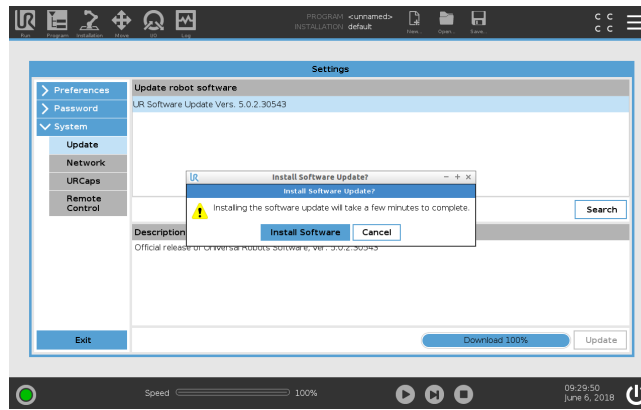

11. The robot will power off and power on again. Once the update is complete, the Control Box automatically reboots. **Do not power off or unplug the robot from the outlet during startup.**
12. Wait until the reboot is complete. Firmware for the control Box and Tech Pendant is updated.
13. When complete, go to the Initialize screen and press ON, if available joint firmware is going to update.

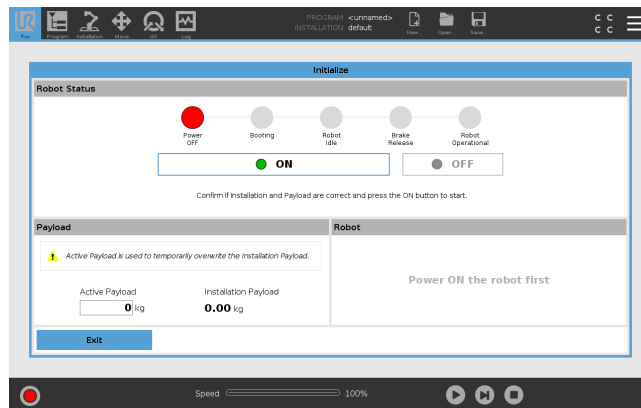

14. Remove the USB stick.

5.3. Using Support File

For easy backup, Universal Robots provides a feature called Support File, an automatically copy of the robot data from Control Box to the USB stick.

1. Access the Log tab, insert a USB stick and tap Support File.



NOTICE

This backup requires around 1Gb capacity, use a USB stick of 2Gb or more capacity.



NOTICE

Always perform program and installation files backup before updating the software.

5.4. Using Magic Files

For easy backup, Universal Robots provides Magic Files to automatically copy data from Control Box to USB stick. Magic files backup works with all software versions, execution of magic files could be disabled in General Security Settings.



NOTICE

Always perform program and installation files backup before updating the software.

Available file	Function
URmagic log file	Copies the entire log history file to USB stick
URmagic backup programs	Copies all programs and installation files to USB stick
URmagic configuration files	Copies all configuration files to USB stick
URmagic upload programs	Copies all programs and installation files from a USB-stick to the robot
URmagic screenshot	Generates a screenshot of GUI when USB stick is inserted

You can download Magic Files at: www.universal-robots.com/support

To use Magic Files:

1. Download and save Magic Files to the root folder on a USB stick. If more than one Magic File is on the USB stick, they run in sequence. Warnings appear for each file. Do not remove the USB stick until the last file has finished. Multiple folders are created and named with serial number as well as a sequence number (e.g., 201855xxxx_0, 201855xxxx_1).
2. Insert a USB stick into the USB connector located on the top right side of the Teach Pendant.
3. A red **!USB!**-sign appears on the screen. Do not remove the USB stick.
4. Wait for a green **<-USB**-sign to appear. If more than one Magic File is on the USB stick, proceed to Step 3. NOTE: Large files (e.g., history log) may take up to 2 minutes to download.
5. After the last Magic File is completed the USB stick can be safely removed.

The Magic File creates a folder on the USB stick named with the serial number of the robot.

5.5. Backup of data



NOTICE

When copying/moving files and folders, incorrect use might corrupt the file system. Contact your IT professional for assistance if you are not comfortable with this procedure.

This section explains the process of moving required files during a robot backup.

5.5.1. Hardware Requirements

The following hardware is needed:

- SD Card (Universal Robots 4GB Industrial grade SD card)
- A standard SD card reader

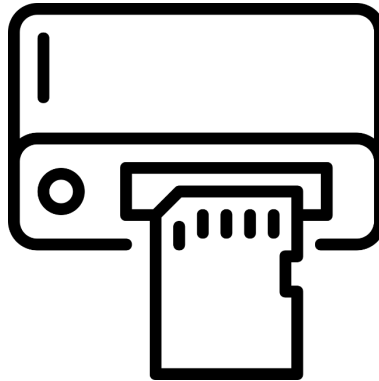

5.5.2. Software Requirements

When using Windows operation system, to read a Linux partition a software file system driver is required; in this example we are using “Linux File Systems for Windows” by Paragon but other Windows Linux reader can be used as well (these are however not tested by Universal Robots).



NOTICE

“Linux File Systems for Windows” by Paragon software is a third-party software. Universal Robot takes no responsibility for third-party software.

5.5.3. Accessing Linux Partition from Windows

With the software from Paragon you can access all partitions on the SD-card.

The files needed are located on the partition called: **datafs**

If the partition is not shown, it could be due to the files not being mounted automatically.

To correct this:

1. Open the Paragon software.
2. Select the partition (1).
3. Select the Mount icon (2).
4. Select the Volume drive letter (3).
5. Then Mount (4).

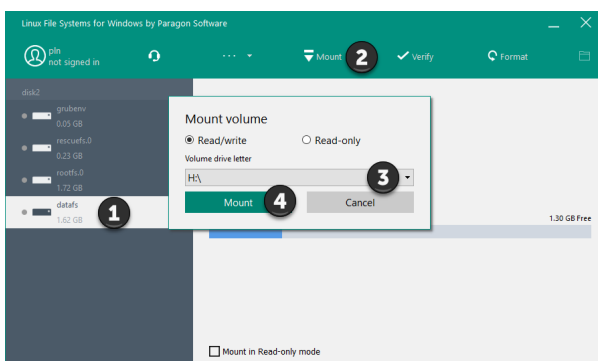

5.5.4. Copying the data from SD card

Navigate to the SD card partition called **datafs** and copy the below listed files/folders.



NOTICE

Do not alter any files. You must only take backup copies as needed.

- programs/ [all of the following files: .urp, .txt, .script, .installation, .variable, .old]
- root/ur-serial
- root/log_history.txt
- root/log_history.bak [if existing]
- root/histogram.properties
- root/flightreports [Complete folder if existing]
- root/.urcontrol/calibration.conf
- root/.urcontrol/calibration.log
- root/.urcontrol/robot_calibration_summary.txt

6. Troubleshooting

6.1. Adding External Equipment for Troubleshooting Purpose

For troubleshooting it can be useful to add a mouse, keyboard or monitor. Most USB mouse and keyboard types are supported. You can plug the mouse or keyboard in one of the available USB ports. A Control Box restart may be required.

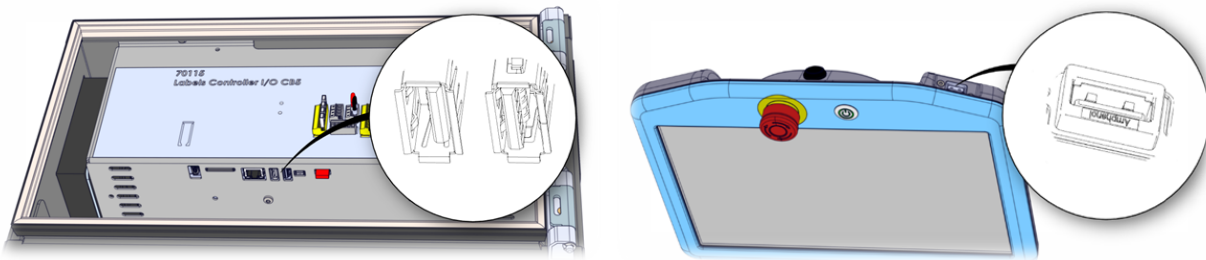

In the Control Box bracket, a Mini Display Port is available. When a monitor is connected, it displays the same content as the Teach Pendant. Both can be connected at the same time. It may be required to restart the Control Box for it to work.

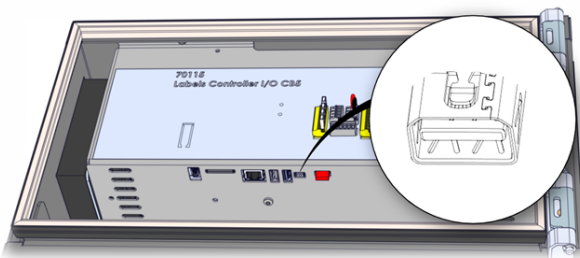

6.2. UR Log Viewer

The UR Log Viewer is a software intended for reading and viewing the support file from the UR robot/s. Support files are generated automatically inside each robot, and contain the log files, programs and flight reports. This software is a support tool for the user to troubleshoot as needed. It is a tool for understanding the robot behavior and have data analysis, as well to do improvements, based on this data, to your application and programming.

Go to www.universal-robots.com/support to download the UR log viewer and find the full instruction

6.3. LED indicators and Fuse on Safety Control Board

6.3.1. LED Indicators on Safety Control Board

The below LEDs are “power” LEDs. They are either on or off.

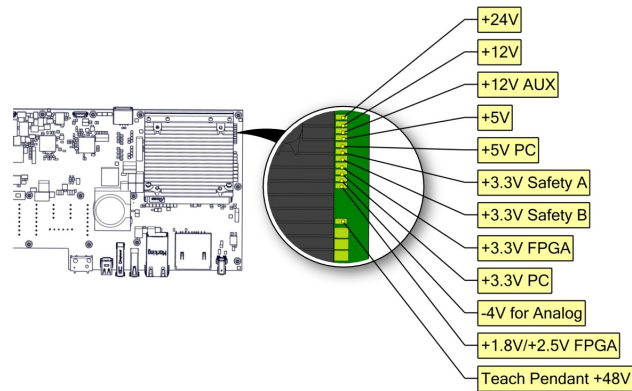

LED for power

- Green color permanent = Power on
- No color permanent = Error or no power

Below are “communication” LEDs. They flash in different patterns, depending on the status.

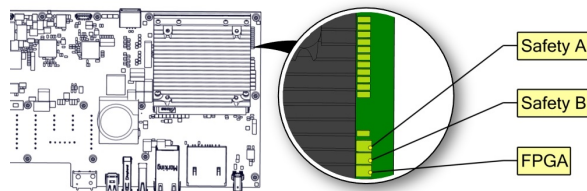

LED for Safety A and Safety B

Green fast flash = Bootloader

Green slow flash = Normal communication

Red permanent = Error (Red flash can happen during bootup/power on, this is normal.)

LED for FPGA

Green/Red permanent = Normal communication

Green slow flash = No communication/trying to establish communication

6.3.2. Fuse

The fuse is a 10A fast-acting mini blade fuse.



CAUTION

Using an inferior fuse can lead to safety hazards.

- Never use a different fuse than specified. Only use high grade components.

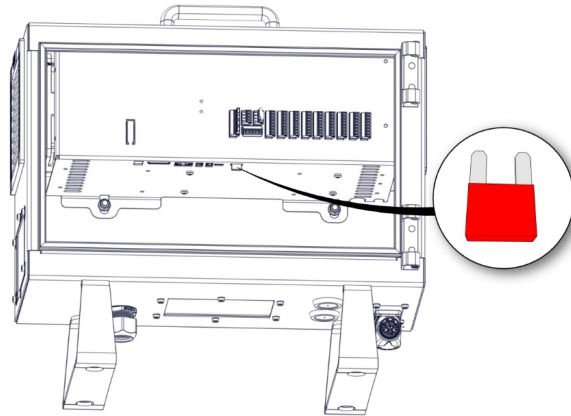

Fuse specifications:

- Interrupting Rating: 1000A @ 32 VDC
- Voltage Rating: 32 VDC
- Component Level Temperature Range: -40 °C to +125 °C
- System Level Temperature Range: -40 °C to +105 °C
- Terminals: Ag plated zinc alloy
- Housing Material: PA66
- Complies with: SAE J2077, ISO 8820-3
- UL 248 Special Purpose Fuses

6.4. Complete Rebooting Sequence

To completely reboot the robot system, follow the following steps:

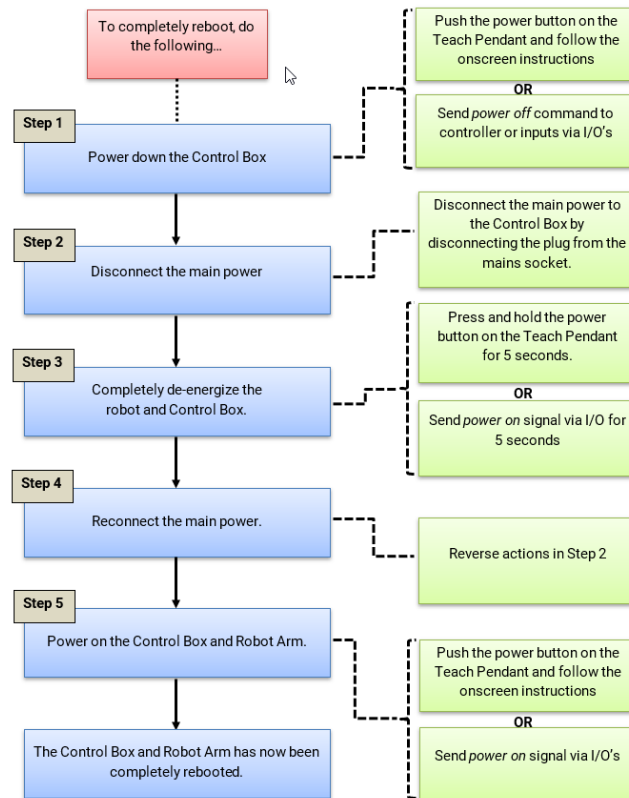

6.5. Robot Stop

Read also article 18939 on the support site www.universal-robots.com/support

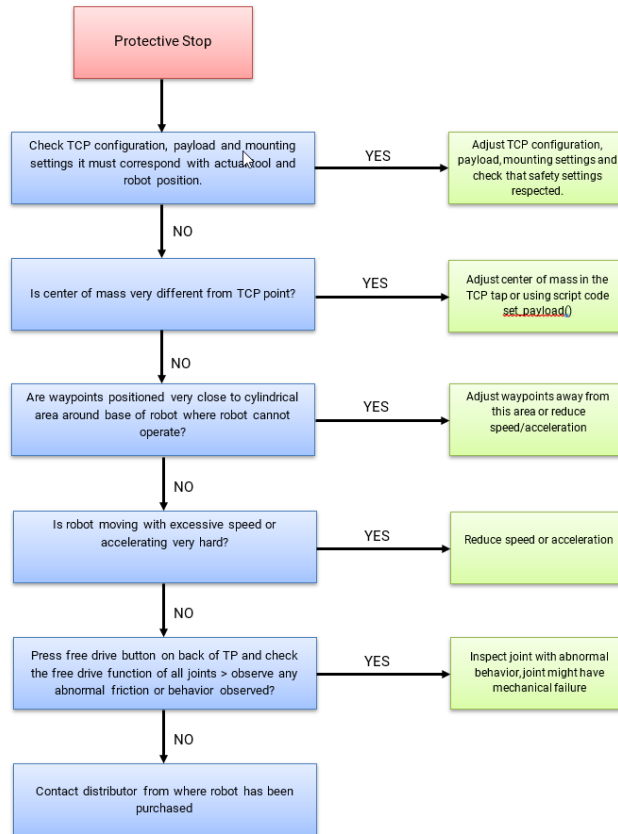

6.5.1. Ignoring Robot Stops

Ignoring protective stops is considered abuse of the robot which voids the warranty.

These faults can be hidden from view under the following two circumstances:

1. Personnel simply resetting a fault without review of why the fault has happened.



WARNING

Ignoring protective stops masks fault detection, which can increase the risk of injury.

- Pay careful attention to protective stops.
Learn why they happen to improve your programs and preserve fault detection.

Protective stops must never be acknowledged and reset automatically, it must always be a deliberate action by a user to resume after a protective stop.

In general, protective stops are designed to inform the user that the robot has stopped due to an external event such as hitting an obstacle or similar. In case the robots are pushed close to the limits, the robots can generate protective stops to indicate that they are not capable of following the desired trajectory. After a protective stop, the following must be done before resuming operation:

- If there has been a collision or similar:**
Remove the obstacle and ensure that operators are out of the way before resuming operation. See Section 2 of Service Manual (see link below).
- If there has been NO collision or similar:**
The robot is operating too close to the limits, the application should be adjusted to reduce the load on the robot, for instance by reducing accelerations, by correct use of blends or similar measures.

Protective stops are indications of issues, including program or production issues - not only safety issues. An application which results in daily protective stops is not designed correctly and needs to be modified.

2. If an automatic acknowledgment and reset of a protective stop has been programmed - no one will see the protective stop.

**NOTICE**

Automatic acknowledgment and reset of protective stops masks faults that will lead to a failure condition.

- When there is a protective stop, verify the cause.
If there is no collision, adjust the program

If an integrator has set-up the application program to do automatic acknowledgement and reset of protective stops, the customer should contact the integrator change the program immediately, as such override voids the product warranty and masks fault detection.

6.6. Safe Brake System

UR20 and UR30 robots will perform a procedure prior to powering off the motors during shutdown, violation or E-stop where it will detect whether or not the brake system in the robot arm engaged successfully.

In the event that it is detected that the brake system did not engage, then power to the joint motors will be kept on. The arm will be kept at standstill until an operator powers off the arm in a controlled way.

**NOTICE**

The robot will also perform this detection during when leaving backdrive, although in this case, it will keep the motors powered off.

When the system enters this state, the following screen will appear in the PolyScope user interface:

Long-pressing the exclamation mark icon will bring up a special power off screen.



CRITICAL - Brake system error

Important: Keep the power ON

Keep a distance to the robot - If power is lost or removed, the robot might collapse, which can cause serious damage or injury

Please contact Universal Robots local team to get further guidance



Link: <https://www.universal-robots.com/articles/ur/safety/safe-brake-system>
Scan the QR code to get further information

Copyright © 2009-2024 by Universal Robots A/S. All rights reserved.

6.6.1. Finding the Faulty Joint

Here the operator can see which joint detected a faulty brake.

An entry will also be added to the log where it can be seen which joint detected a faulty brake.

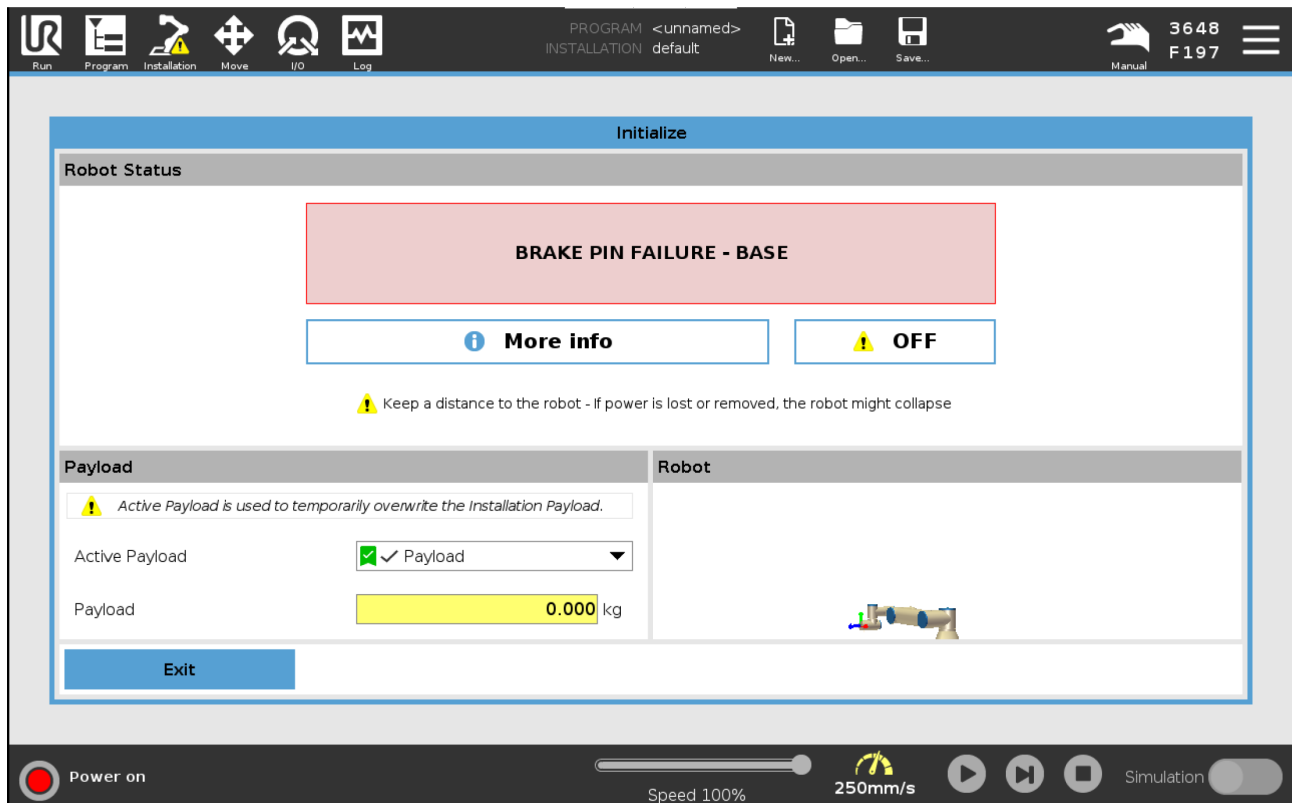

When the robot is in this state, the dashboard server will not respond normally when queried. It will respond to all requests with information about that the robot encountered a brake system error and a link where further information can be found.

Before powering the robot off in this scenario, the operator needs to ensure that it will not cause any harm to personnel or damage to equipment beneath the robot, as it is likely that the brake will not be engaged, and thus the affected joint will not be able to keep the arm from sliding downwards once the power is removed.

Further operation of the robot will be prevented as the robot will be unable to brake release until the robot has been inspected to ensure the brake is operating properly.

The operator or a service technician need to validate that the brake of the previously reported joint is able to engage before proceeding with the steps in the section Clearing a brake system error.

If the brake is faulty, the brake failure should only be cleared in the case that it is necessary for getting the robot in a position where it can be shipped to a service facility.

To repair the faulty brake system, a service technician should first attempt to replace the brake solenoid in the joint. If that does not resolve the issue, it is likely to be a problem with the friction brake.

6.6.2. Validate Joint Brake System

If it is suspected that the detection of a faulty brake system was due to a false detection, and that there is not anything wrong with the brake system, a manual inspection can be done.

In that case, the operator should note which joint is reported to have a faulty brake system. If in doubt, powering up the robot again after the control box is restarted will show the brake system error popup screen again and make the user interface show which joint is faulty.

To inspect the brake, move the part of the robot arm connected to the faulty joint in both directions to evaluate if it hits the brake pin or not. If the brake is correctly engaged only very limited motion of the joint (1-2 degrees) will be possible before hitting the brake pin.

6.6.3. Clearing the Brake System Error

Using this method to make the robot continue operating should only be done if the operator or service technician is sure that the brake system error was due to a false detection and the brake is actually working correctly.



CAUTION

If the robot arm slid downwards towards the ground after the initial detection when it was first powered off, the robot brake system is faulty and should be serviced.

If repeated brake system errors occurs, the robot should be serviced even if it seems like it is a false detection as it could be a sporadic issue if e.g. the brake solenoid is binding and slow to engage. If it is necessary to brake release the robot to get it in a position suitable for shipping to a service center, this procedure can be used.

Use the steps below to clear a brake system error:

1. Attach an USB keyboard.
2. Make sure that there is power to the robot arm. If the system is in the brake failure state and powered off, it is necessary to restart the control box to power on the robot arm again. When powering on the robot arm, it will go to the brake failure state.

3. Use the USB keyboard to change to a "Virtual Terminal" by pressing CTRL-ALT-F1
4. Login in the terminal using `root` as username and the configured root password. (`easybot` is the default password).

5. Enter the following command and press enter

```
echo "clear failed brake <joint>" | nc 127.0.0.1 30001 -q0
```

where `<joint>` should be replaced with a number 0-5 corresponding to which joint should clear the failed brake state. e.g. for clearing it on the shoulder joint, enter `echo "clear failed brake 1" | nc 127.0.0.1 30001 -q0`

6. Change back to polscope by pressing CTRL-ALT-F7
7. Power off the robot arm and restart the control box.
8. It is now possible to brake release the robot.

7. Electrical drawings

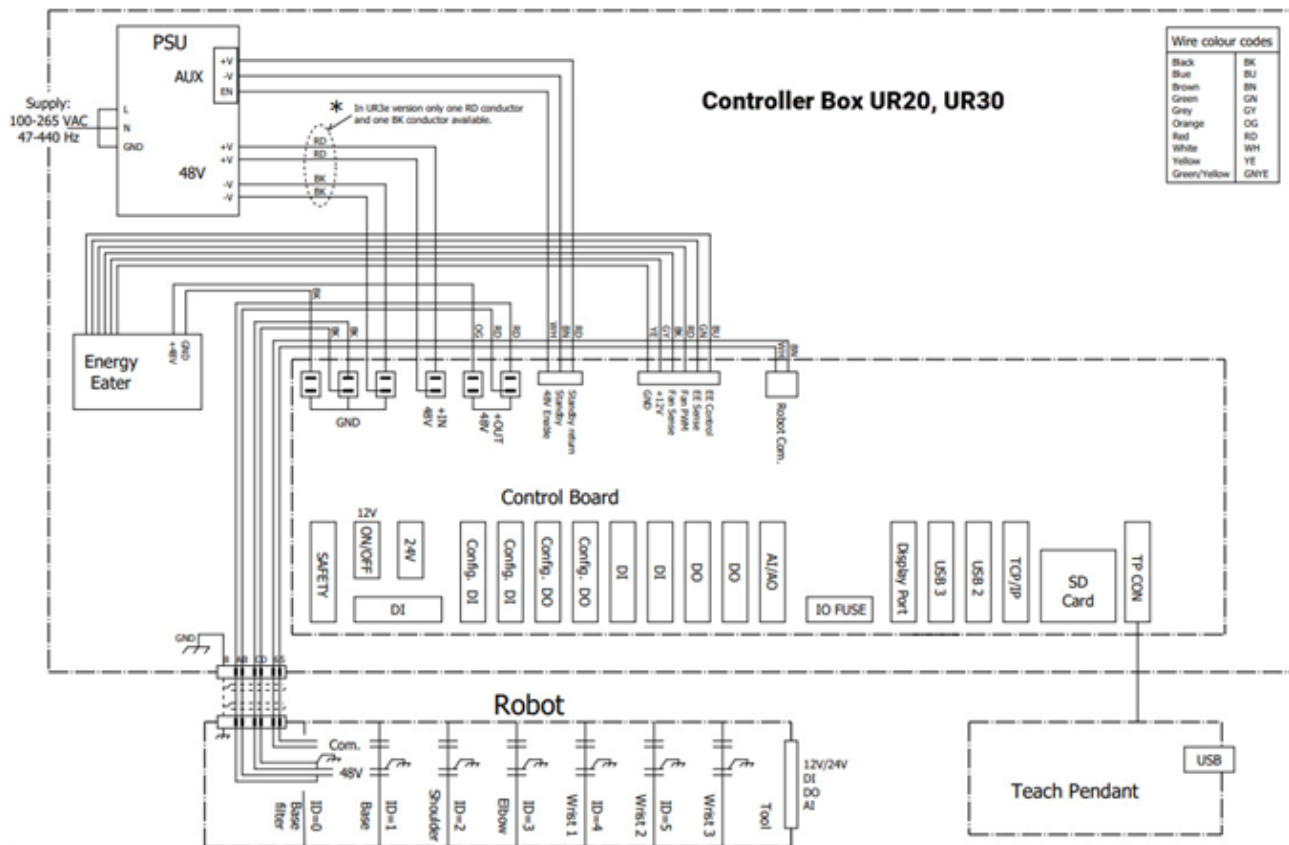
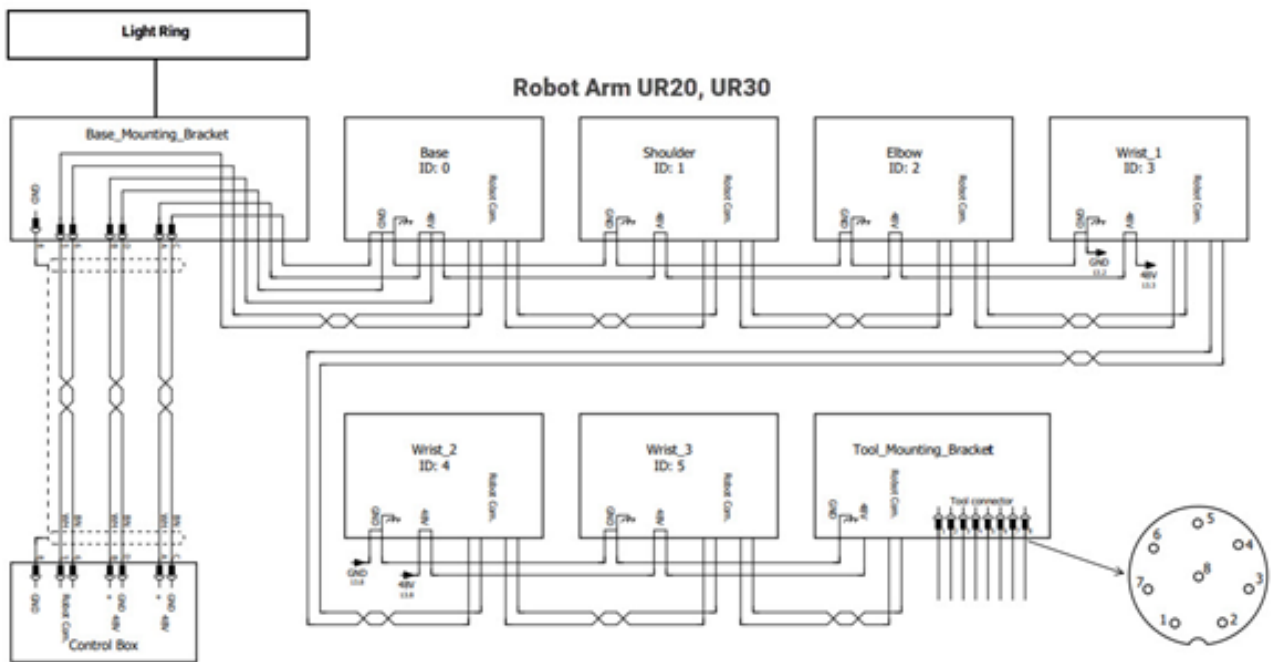

Copyright © 2009-2024 by Universal Robots A/S. All rights reserved.

8. Spare Parts



NOTICE

Ensure you have the correct part numbers when ordering spare parts.

The full list of spare parts have been moved to the support section on Universal Robot's website:
<https://www.universal-robots.com/support/>

9. Packing and Shipping of Robot/Spare Parts

Before shipping any robots or spare parts back to Universal Robots, verify the following:

- All external tools and external electrical connections are removed.
- The robot arm, Control Box, and Teach Pendant are packed responsibly.



NOTICE

Universal Robots can reject the shipment if third party products cannot be unmounted safely, or if they prohibit the execution of required post repair tests. Universal Robots assumes no responsibility for the return shipment of third party goods. Universal Robots returns Universal Robots products in original Universal Robots packaging.



NOTICE

The robot software/firmware is updated when repaired. New parts are also updated to their newest versions (hardware/software).

- Updating PolyScope may be necessary when new parts are mounted.



WARNING

Failure to clean robot/part(s) that have been contact with, or worked in environments, where dangerous chemicals or materials are present, can increase the risk of serious injury.

- Clean the exposed robot/part(s) before shipment.
- If cleaning is not possible, the shipment must be accompanied by an MSDA (Material Safety Data Sheet) in English and include instructions for cleaning. The amount of labor hours needed for cleaning will be billed at the standard rate.

If Universal Robots finds the robot/part unsafe to service, UR reserves the right to get the robot/part(s) cleaned or decline the case and send the part(s) back at customers expense.

To packing down the robot and Control Box:

1. Download the put_in_box program at: www.universal-robots.com/support
2. Upload the put_in_box program. See Section 5.2 Using Magic Files on how to do this.
3. Load the program and follow the instructions when running the program.
4. Power down, disconnect main power, and disconnect the Robot Arm from controller.
5. Pack the Robot Arm and Control Box in designated boxes. Ensure the Robot Arm is orientated correctly in the box.

**NOTICE**

Transporting the robot without its original packaging voids all warranties from Universal Robots A/S.

If the robot is transported attached to a 3rd-party application / installation, see the recommendations for transporting the robot without the original transport packaging.

You can see the recommendations for transportation without packaging on help.universal-robots.com/

If the robot arm cannot be moved, due to faults preventing the robot arm from releasing brakes. It may be necessary to disassemble the arm into two parts between the elbow joint and upper arm tube, and strap it securely to a pallet with two straps on the each tube before shipping. This will not void the warranty.

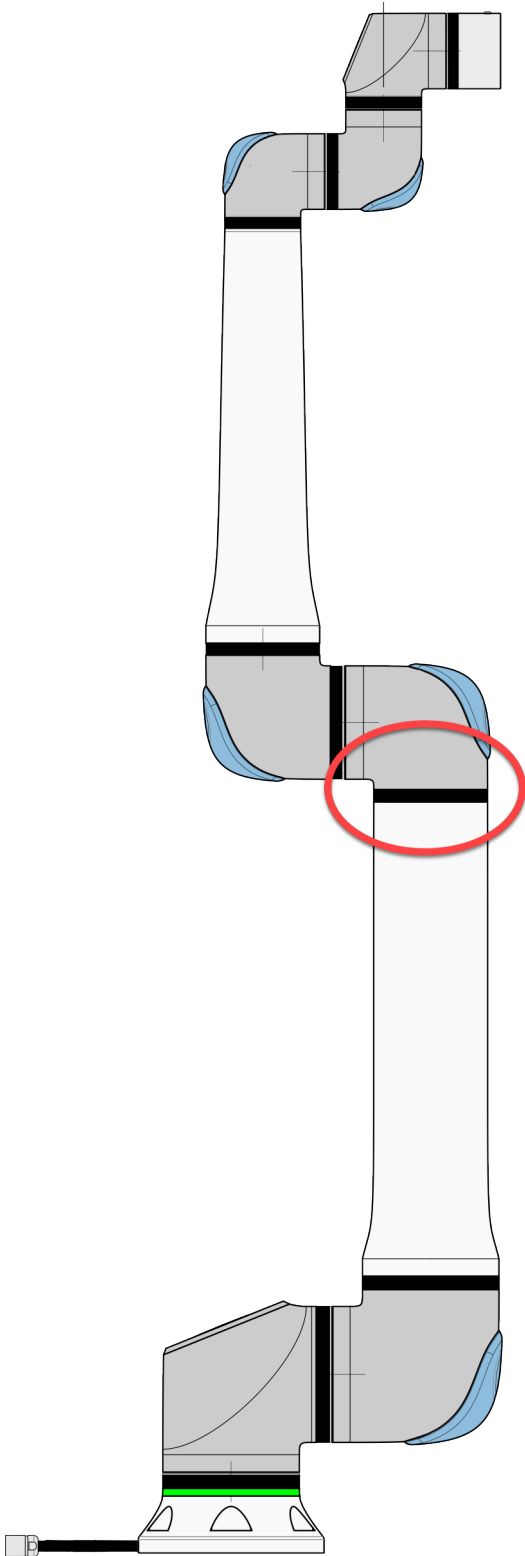

Copyright © 2009-2024 by Universal Robots A/S. All rights reserved.

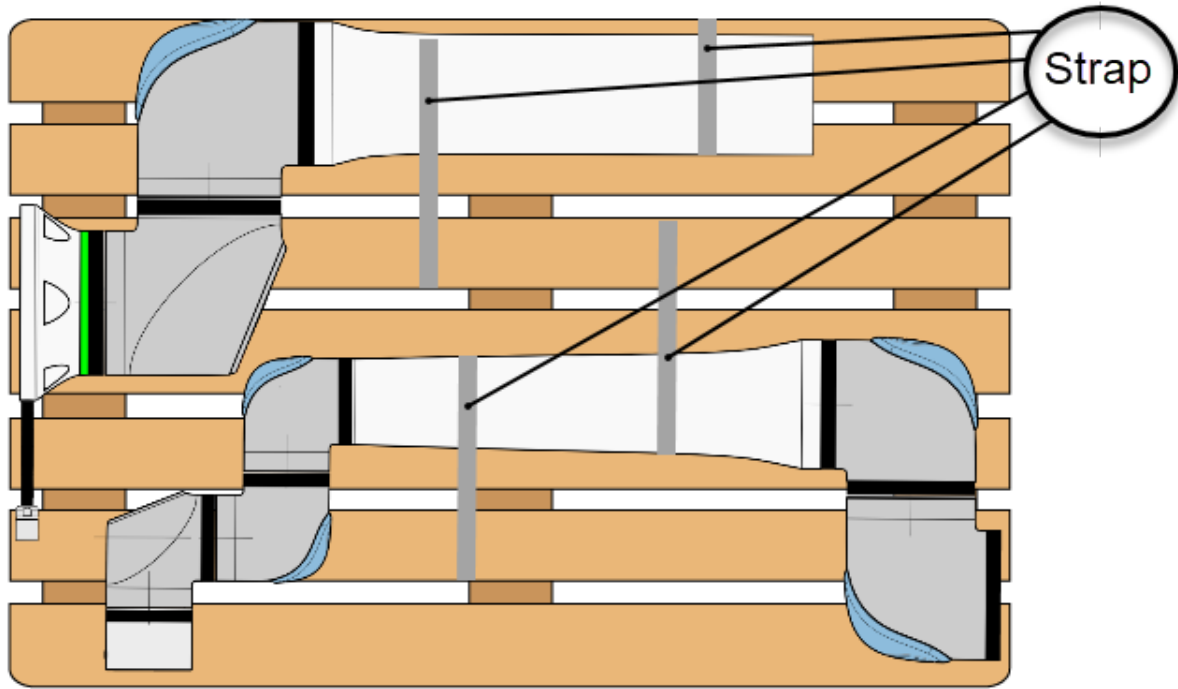

9.1. Transport Without Packaging

Description

Universal Robots always recommends transporting the robot in its original packaging. These recommendations are written to reduce unwanted vibrations in joints and brake systems and reduce joint rotation.

If the robot is transported without its original packaging, then please refer to the following guidelines:

- Fold the robot as much as possible - do not transport the robot in the singularity position.
- Move the center of gravity in the robot as close to the base as possible.
- Secure each tube to a solid surface on two different points on the tube.
- Secure any attached end effector rigidly in 3 axes.

Transport

Fold the robot as much as possible.

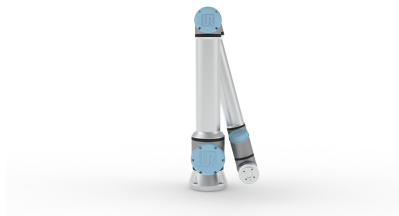

Do not transport extended. (singularity position)

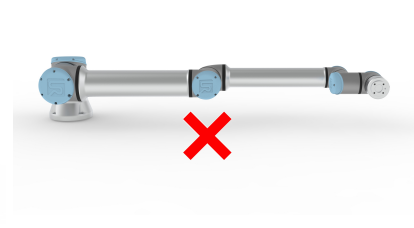
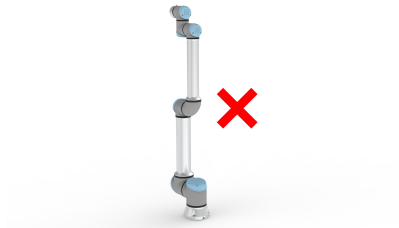

Secure the tubes to a solid surface. Secure attached end effector in 3 axes.

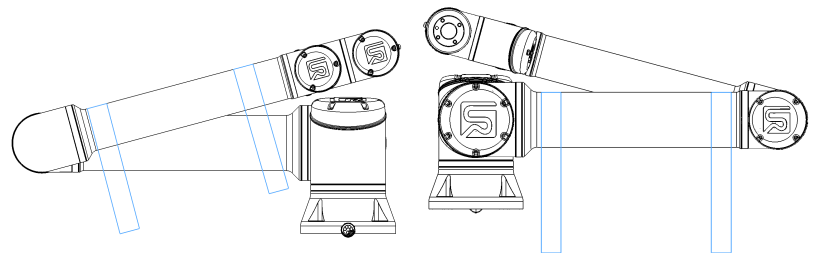

10. Change log

Date	Revision	Action	Changes
March 2023	1.0.0	Started	
July 2023	1.1.0		Safety msgs etc
Dec 2023	1.2.0		Added UR30

10. Change log

Software Name: PolyScope 5

Software Version: 5.20

Document Version: 10.8.158

