

Thermo

# Accela Autosampler

## Hardware Manual

60357-97000 Revision K December 2013



**Thermo**  
SCIENTIFIC

© 2013 Thermo Fisher Scientific Inc. All rights reserved.

Accela, ChromQuest, and Xcalibur are registered trademarks of Thermo Fisher Scientific Inc. in the United States.

Tri-Flow is a trademark of Sherwin-Williams Company. PEEK is a trademark of Victrex PLC. VIEWseal and POWERseal are trademarks of Greiner Bio One.

The following are registered trademarks in the United States and other countries: Teflon is a registered trademark of E. I. du Pont de Nemours and Company. Rheodyne is a registered trademark of Rheodyne, LLC. Valco is a registered trademark of Valco Instruments Co. Inc. and VICI AG. Upchurch is a registered trademark of IDEX Corporation.

HyperTerminal is a registered trademark of Hilgraeve, Inc. in the United States.

Thermo Fisher Scientific Inc. provides this document to its customers with a product purchase to use in the product operation. This document is copyright protected and any reproduction of the whole or any part of this document is strictly prohibited, except with the written authorization of Thermo Fisher Scientific Inc.

The contents of this document are subject to change without notice. All technical information in this document is for reference purposes only. System configurations and specifications in this document supersede all previous information received by the purchaser.

This document is not part of any sales contract between Thermo Fisher Scientific Inc. and a purchaser. This document shall in no way govern or modify any Terms and Conditions of Sale, which Terms and Conditions of Sale shall govern all conflicting information between the two documents.

Release history: Revision A, Sept 2006; Revision B, Jan 2007; Revision C, Mar 2008; Revision D, Feb 2009; Revision E, Oct2009; Revision F, Apr 2010; Revision G, Mar 2011; Revision H, Oct 2011; Revision I (J), Jan 2012; Revision K, Dec 2013

This revision contains cosmetic changes only. The cosmetic changes include a new title page and chapter icon. In addition, the pagination might differ slightly from the last revision.

Software versions: Thermo Foundation 1.0.x or later, Xcalibur 2.0.x or later, ChromQuest 4.2 or later

**For Research Use Only. Not for use in diagnostic procedures.**



## Regulatory Compliance

Thermo Fisher Scientific performs complete testing and evaluation of its products to ensure full compliance with applicable domestic and international regulations. When the system is delivered to you, it meets all pertinent electromagnetic compatibility (EMC) and safety standards as described in the next section or sections by product name.

Changes that you make to your system may void compliance with one or more of these EMC and safety standards. Changes to your system include replacing a part or adding components, options, or peripherals not specifically authorized and qualified by Thermo Fisher Scientific. To ensure continued compliance with EMC and safety standards, replacement parts and additional components, options, and peripherals must be ordered from Thermo Fisher Scientific or one of its authorized representatives.

### Accela Autosampler

#### **EMC Directive 89/336/EEC amended by 92/31/EEC and 93/68/EEC**

EMC compliance has been evaluated by TUV Rheinland of North America, Inc.

EN 61000-3-2: 2000	EN 61000-4-6: 2003
EN 61000-3-3: 1995; A1: 2001	EN 61000-4-8: 2001
EN 61000-4-2: 2001	EN 61000-4-11: 2001
EN 61000-4-3: 2002	EN 61326:1997; A1: 1998; A2: 2001; A3: 2003
EN 61000-4-4: 1995; A1: 2000; A2: 2001	FCC Class A, CFR 47 Part 15 Subpart B: 2005
EN 61000-4-5: 2001	

#### **Low Voltage Safety Compliance**

Low Voltage Safety Compliance has been evaluated by TUV Rheinland of North America, Inc.

This device complies with Low Voltage Directive 73/23/EEC and the following harmonized standards: EN 61010-1:2001, IEC 61010-1:2002, UL 61010 A-1:2004, CAN/CSA 22.2 61010-1:2004.

### FCC Compliance Statement

THIS DEVICE COMPLIES WITH PART 15 OF THE FCC RULES. OPERATION IS SUBJECT TO THE FOLLOWING TWO CONDITIONS: (1) THIS DEVICE MAY NOT CAUSE HARMFUL INTERFERENCE, AND (2) THIS DEVICE MUST ACCEPT ANY INTERFERENCE RECEIVED, INCLUDING INTERFERENCE THAT MAY CAUSE UNDESIRE OPERATION.
------------------------------------------------------------------------------------------------------------------------------------------------------------------------------------------------------------------------------------------------------------------------------------



**CAUTION** Read and understand the various precautionary notes, signs, and symbols contained inside this manual pertaining to the safe use and operation of this product before using the device.

## Notice on Lifting and Handling of Thermo Scientific Instruments

For your safety, and in compliance with international regulations, the physical handling of this Thermo Fisher Scientific instrument *requires a team effort* to lift and/or move the instrument. This instrument is too heavy and/or bulky for one person alone to handle safely.

## Notice on the Proper Use of Thermo Scientific Instruments

In compliance with international regulations: This instrument must be used in the manner specified by Thermo Fisher Scientific to ensure protections provided by the instrument are not impaired. Deviations from specified instructions on the proper use of the instrument include changes to the system and part replacement. Accordingly, order replacement parts from Thermo Fisher Scientific or one of its authorized representatives.

## Notice on the Susceptibility to Electromagnetic Transmissions

Your instrument is designed to work in a controlled electromagnetic environment. Do not use radio frequency transmitters, such as mobile phones, in close proximity to the instrument.

For manufacturing location, see the label on the instrument.

## WEEE Compliance

This product is required to comply with the European Union's Waste Electrical & Electronic Equipment (WEEE) Directive 2002/96/EC. It is marked with the following symbol:



Thermo Fisher Scientific has contracted with one or more recycling or disposal companies in each European Union (EU) Member State, and these companies should dispose of or recycle this product. See [www.thermoscientific.com/rohswее](http://www.thermoscientific.com/rohswее) for further information on Thermo Fisher Scientific's compliance with these Directives and the recyclers in your country.

## WEEE Konformität

Dieses Produkt muss die EU Waste Electrical & Electronic Equipment (WEEE) Richtlinie 2002/96/EC erfüllen. Das Produkt ist durch folgendes Symbol gekennzeichnet:








Thermo Fisher Scientific hat Vereinbarungen mit Verwertungs-/Entsorgungsfirmer in allen EU-Mitgliedsstaaten getroffen, damit dieses Produkt durch diese Firmen wiederverwertet oder entsorgt werden kann. Mehr Information über die Einhaltung dieser Anweisungen durch Thermo Fisher Scientific, über die Verwerter, und weitere Hinweise, die nützlich sind, um die Produkte zu identifizieren, die unter diese RoHS Anweisung fallen, finden sie unter [www.thermoscientific.com/rohswее](http://www.thermoscientific.com/rohswее).







## Conformité DEEE

Ce produit doit être conforme à la directive européenne (2002/96/EC) des Déchets d'Equipements Electriques et Electroniques (DEEE). Il est marqué par le symbole suivant:



Thermo Fisher Scientific s'est associé avec une ou plusieurs compagnies de recyclage dans chaque état membre de l'union européenne et ce produit devrait être collecté ou recyclé par celles-ci. Davantage d'informations sur la conformité de Thermo Fisher Scientific à ces directives, les recycleurs dans votre pays et les informations sur les produits Thermo Fisher Scientific qui peuvent aider la détection des substances sujettes à la directive RoHS sont disponibles sur [www.thermoscientific.com/rohsweee](http://www.thermoscientific.com/rohsweee).

CAUTION Symbol	CAUTION	VORSICHT	PRECAUCIÓN	MISE EN GARDE
	<b>Risk electric shock:</b> This instrument uses voltages that can cause electric shock and/or personal injury. Before servicing, shut down the instrument and disconnect it from line power. While operating the instrument, keep covers on. Do not remove the protective covers from the printed circuit board assemblies (PCBAs).	<b>Stromschlaggefahr:</b> Dieses Gerät arbeitet mit Spannungen, die Stromschläge und/oder Personenverletzungen verursachen können. Vor Wartungsarbeiten muss das Gerät abgeschaltet und vom Netz getrennt werden. Betreiben Sie das Gerät nicht mit abgenommenen Abdeckungen. Nehmen Sie die Schutzabdeckungen von Leiterplatten nicht ab.	<b>Riesgo de descargas eléctricas:</b> Este instrumento utiliza voltajes que pueden causar descargas eléctricas y/o lesiones personales. Antes de revisar o reparar el instrumento, apáguelo y desconéctelo de la red eléctrica. Mantenga colocadas las cubiertas mientras se utiliza el instrumento. No retire las cubiertas protectoras del circuito impreso completo (PCBA).	<b>Risque de choc électrique :</b> l'instrument utilise des tensions susceptibles de provoquer une électrocution et/ou des blessures corporelles. Il doit être arrêté et débranché de la source de courant avant toute intervention. Ne pas utiliser l'instrument sans ses couvercles. Ne pas enlever les capots de protection des cartes à circuit imprimé (PCBA).
	<b>Chemical hazard:</b> Wear gloves and other protective equipment, as appropriate, when handling toxic, carcinogenic, mutagenic, corrosive, or irritant chemicals. Use approved containers and proper procedures to dispose of waste oil and when handling wetted parts of the instrument.	<b>Gefahr durch Chemikalien:</b> Tragen Sie beim Umgang mit toxischen, karzinogenen, mutagenen, ätzenden oder reizenden Chemikalien Schutzhandschuhe und weitere geeignete Schutzausrüstung. Verwenden Sie bei der Entsorgung von verbrauchtem Öl und beim Umgang mit medienberührenden Komponenten die vorgeschriebenen Behälter, und wenden Sie ordnungsgemäße Verfahren an.	<b>Peligro por sustancias químicas:</b> Cuando manipule sustancias químicas, tóxicas, carcinogénicas, mutágenas, corrosivas o irritantes, utilice guantes y otro equipo de protección. Utilice siempre recipientes homologados y siga los procedimientos adecuados cuando deseche aceite residual o manipule partes mojadas del instrumento.	<b>Danger lié aux produits chimiques :</b> porter des gants et d'autres équipements de protection appropriés pour manipuler les produits chimiques toxiques, cancérogènes, mutagènes, corrosifs ou irritants. Utiliser des récipients homologués et des procédures adéquates pour la mise au rebut des huiles usagées et lors de la manipulation des pièces de l'instrument en contact avec l'eau.
	<b>Hot surface:</b> Before touching, allow any heated components to cool.	<b>Heiße Oberflächen:</b> Lassen Sie heiße Komponenten vor der Berührung abkühlen.	<b>Superficies calientes:</b> Antes de tocar los componentes calientes, espere a que se enfríen.	<b>Surface chaude :</b> laisser refroidir les composants chauffés avant toute manipulation.
	<b>Flammable substances hazard:</b> Use care when operating the system in the presence of flammable substances.	<b>Gefahr durch entzündbare Substanzen:</b> Beachten Sie die einschlägigen Vorsichtsmaßnahmen, wenn Sie das System in Gegenwart von entzündbaren Substanzen betreiben.	<b>Peligro por sustancias inflamables:</b> Tenga mucho cuidado cuando utilice el sistema cerca de sustancias inflamables.	<b>Danger lié aux substances inflammables :</b> agir avec précaution lors de l'utilisation du système en présence de substances inflammables.
	<b>Risk of eye injury:</b> Eye injury could occur from splattered chemicals, airborne particles, or sharp objects. (Sharp objects that customers might install in the instrument include fused-silica tubing, the autosampler needle, and so on.) Wear safety glasses when handling chemicals or servicing the instrument.	<b>Augenverletzungsrisiko:</b> Verspritzte Chemikalien, Schwebstoffpartikel oder scharfe Objekte können Augenverletzungen verursachen. (Scharfe Objekte, die Kunden möglicherweise im Gerät installieren, sind z. B. Quarzglas-Kapillaren, die Nadel des Autosamplers, usw.) Tragen Sie beim Umgang mit Chemikalien oder bei der Wartung des Gerätes eine Schutzbrille.	<b>Riesgo de lesiones oculares:</b> Las salpicaduras de sustancias químicas, las partículas flotantes en el aire y los objetos afilados pueden causar lesiones oculares. (Entre los objetos afilados que los clientes pueden instalar en el instrumento se encuentran tubos de sílice fundida, agujas del muestreador automático, etc.). Para manipular sustancias químicas o realizar tareas de mantenimiento, utilice gafas de seguridad.	<b>Risque de lésion oculaire :</b> les projections chimiques, les particules en suspension dans l'air et les objets tranchants peuvent entraîner des lésions oculaires. (Les objets tranchants pouvant être installés par les clients dans l'instrument comprennent les tubes en silice fondue, les aiguilles du passeur automatique, etc.). Porter des lunettes de protection lors de toute manipulation de produit chimique ou intervention sur l'instrument.
	<b>General hazard:</b> A hazard is present that is not included in the other categories. This symbol also appears on the instrument. For details about the hazard, refer to the instrument manual. When the safety of a procedure is questionable, contact Technical Support for Thermo Scientific San Jose products.	<b>Allgemeine Gefahr:</b> Es besteht eine weitere Gefahr, die nicht in den vorstehenden Kategorien beschrieben ist. Dieses Symbol wird auch auf dem Gerät angebracht. Einzelheiten zu dieser Gefahr finden Sie in den Gerätehandbüchern. Wenn Sie sich über die Sicherheit eines Verfahrens im Unklaren sind, setzen Sie sich, bevor Sie fortfahren, mit dem technischen Support für Thermo Scientific San Jose Produkte in Verbindung.	<b>Peligro general:</b> Existen peligros que no se incluyen en las otras categorías. Este símbolo también aparece en el instrumento. Si desea obtener más información sobre estos peligros, consulte el manual del instrumento. En caso de duda sobre la seguridad de un procedimiento, póngase en contacto con el personal de servicio técnico de los productos Thermo Scientific San Jose.	<b>Danger d'ordre général :</b> indique la présence d'un risque n'appartenant pas aux catégories citées plus haut. Ce symbole figure également sur l'instrument. Pour plus de détails sur ce danger potentiel, se reporter au manuel de l'instrument. Si la sûreté d'une procédure est incertaine, contacter l'assistance technique pour les produits Thermo Scientific San Jose.

CAUTION Symbol	CAUTION	VORSICHT	PRECAUCIÓN	MISE EN GARDE
	<b>Laser hazard:</b> This instrument uses a laser that is capable of causing personal injury. This symbol also appears on the instrument. For details about the hazard, refer to the instrument manual.	<b>Gefahr durch Laserstrahlen:</b> Der in diesem Gerät verwendete Laser kann zu Verletzungen führen. Dieses Symbol wird auch auf dem Gerät angebracht. Einzelheiten zu dieser Gefahr finden Sie in den Gerätehandbüchern.	<b>Peligro por láser:</b> Este instrumento utiliza un láser que puede producir lesiones personales. Este símbolo también aparece en el instrumento. Si desea obtener más información sobre el peligro, consulte el manual del instrumento.	<b>Danger lié au laser :</b> l'instrument utilise un laser susceptible de provoquer des blessures corporelles. Ce symbole figure également sur l'instrument. Pour plus de détails sur ce danger potentiel, se reporter au manuel de l'instrument.
	<b>Ultra violet light hazard:</b> Do not look directly at the ultra-violet (UV) light or into the UV source. Exposure can cause eye damage. Wear UV eye protection.	<b>Gefahr durch UV-Licht:</b> Richten Sie Ihren Blick nicht direkt auf ultraviolettes Licht (UV-Licht) oder in die UV-Quelle. Dies kann zu Augenschäden führen. Tragen Sie eine UV-Schutzbrille.	<b>Peligro por luz ultravioleta:</b> No mire directamente a una luz ultravioleta (UV) ni a una fuente UV. La exposición puede causar daños oculares. Lleve protección ocular para UV.	<b>Danger lié aux rayons ultraviolets :</b> ne jamais regarder directement la lumière ultraviolette (UV) ou la source d'UV. Une exposition peut entraîner des lésions oculaires. Porter des protections oculaires anti-UV.
	<b>Sharp object:</b> Avoid physical contact with the object.	<b>Scharfes Objekt:</b> Vermeiden Sie den physischen Kontakt mit dem Objekt.	<b>Objeto puntiagudo:</b> Evite el contacto físico con el objeto.	<b>Objet tranchant :</b> éviter tout contact physique avec l'objet.
	<b>Pinch point:</b> Keep hands away from this area.	<b>Quetschgefahr:</b> Halten Sie Ihre Hände von diesem Bereich fern.	<b>Puntos de pinzamiento:</b> Mantenga las manos apartadas de esta área.	<b>Risque de pincement :</b> éloigner les mains de cette zone.
	<b>Heavy objects:</b> Never lift or move the instrument by yourself; you can suffer personal injury or damage the equipment. For specific lifting instructions, refer to the instrument manual.	<b>Schweres Objekt:</b> Bewegen und heben Sie das Gerät niemals allein an; dies kann zu Verletzungen oder zur Beschädigung des Geräts führen. Spezifische Anweisungen zum Anheben finden Sie im Gerätehandbuch.	<b>Objeto pesado:</b> Nunca levante ni mueva el instrumento por su cuenta, podría sufrir lesiones personales o dañar el equipo. Para obtener instrucciones específicas sobre levantamiento, consulte el manual del instrumento.	<b>Objet lourd :</b> ne jamais soulever ou déplacer l'instrument seul sous peine de blessure corporelle ou d'endommagement de l'instrument. Pour obtenir des instructions de levage spécifiques, se reporter au manuel de l'instrument.
	<b>Trip obstacle:</b> Be aware of cords, hoses, or other objects located on the floor.	<b>Stolpergefahr:</b> Achten Sie auf Kabel, Schläuche und andere Objekte auf dem Fußboden.	<b>Tropiezo con obstáculos:</b> Tenga en cuenta los cables, mangueras u otros objetos colocados en el suelo.	<b>Risque de trébuchement :</b> faire attention aux câbles, tuyaux et autres objets situés sur le sol.
	When the safety of a procedure is questionable, contact Technical Support for Thermo Scientific San Jose products.	Wenn Sie sich über die Sicherheit eines Verfahrens im unklaren sind, setzen Sie sich, bevor Sie fortfahren, mit Ihrer lokalen technischen Unterstützungsorganisation für Thermo Scientific San Jose Produkte in Verbindung.	En caso de duda sobre la seguridad de un procedimiento, póngase en contacto con el personal de servicio técnico de los productos Thermo Scientific San Jose.	Si la sûreté d'une procédure est incertaine, contacter l'assistance technique pour les produits Thermo Scientific San Jose.

CAUTION Symbol	CAUTION	警告	危険警告
	<p><b>Risk electric shock:</b> This instrument uses voltages that can cause electric shock and/or personal injury. Before servicing, shut down the instrument and disconnect it from line power. While operating the instrument, keep covers on. Do not remove the protective covers from the printed circuit board assemblies (PCBAs).</p>	<p><b>感電の危険性:</b> この機器では、感電および/または身体傷害を引き起こすおそれのある電圧を使用しています。整備点検の前には、機器の電源を切り、電源コードを抜いてください。機器の作動中は、カバーを付けたままにしてください。プリント基板アセンブリ (PCBA) から保護カバーを取り外さないでください。</p>	<p><b>触电危险:</b> 本仪器所用电压可能导致电击或人身伤害。进行维修服务前, 务必关闭仪器电源并断开其电源连接。操作此仪器时, 不要卸下顶盖。勿卸下印刷电路板组件 (PCBA) 的保护盖。</p>
	<p><b>Chemical hazard:</b> Wear gloves and other protective equipment, as appropriate, when handling toxic, carcinogenic, mutagenic, corrosive, or irritant chemicals. Use approved containers and proper procedures to dispose of waste oil and when handling wetted parts of the instrument.</p>	<p><b>化学的危険性:</b> 毒性、発癌性、変異原性、腐食性、または刺激性のある化学薬品を取り扱うときは、必要に応じて手袋などの保護具を着用します。廃油を処分したり、機器の接液部品を取り扱うときは、認可された容器を使用し、適切な手順に従います。</p>	<p><b>化学品危险:</b> 当处理毒性、致癌性、致突变性、腐蚀性或者刺激性化学品时, 佩戴手套和其他保护性设备。当处理浸湿的仪器部件以及废油时, 使用认可的容器和合适的步骤。</p>
	<p><b>Hot surface:</b> Before touching, allow any heated components to cool.</p>	<p><b>高温面:</b> 触れる前に、加熱した部品を冷ましてください。</p>	<p><b>热表面:</b> 待高温部件冷却之后再行维修。</p>
	<p><b>Flammable substances hazard:</b> Use care when operating the system in the presence of flammable substances.</p>	<p><b>可燃性物質の危険性:</b> 可燃性物質があるところでシステムを作動させる場合は十分注意してください。</p>	<p><b>易燃物危险:</b> 在有易燃物质的场地操作该系统时, 务必小心谨慎。</p>
	<p><b>Risk of eye injury:</b> Eye injury could occur from splattered chemicals, airborne particles, or sharp objects. (Sharp objects that customers might install in the instrument include fused-silica tubing, the autosampler needle, and so on.) Wear safety glasses when handling chemicals or servicing the instrument.</p>	<p><b>眼外傷の危険性:</b> 飛散した化学薬品、浮遊粒子、または鋭利な物体によって眼外傷を負うおそれがあります (機器に取り付けられる可能性がある鋭利な物体は、ヒューズドシリカ、オートサンプラーニードルなどです)。化学薬品を取り扱ったり、機器を整備点検するときは、保護メガネを着用します。</p>	<p><b>眼睛伤害风险:</b> 眼睛受伤可能源自飞溅的化学品、空气中的颗粒, 或者锋利的物体。(安装在仪器内的锋利物体包括熔融石英管、自动进样器的进样针等。) 处理化学品或对仪器进行维修服务时, 务必戴上防护眼镜。</p>
	<p><b>General hazard:</b> A hazard is present that is not included in the other categories. This symbol also appears on the instrument. For details about the hazard, refer to the instrument manual. When the safety of a procedure is questionable, contact Technical Support for Thermo Scientific San Jose products.</p>	<p><b>一般的な危険性:</b> それぞれのカテゴリーに当てはまらない危険があります。この標識記号は機器にも表示されています。この危険の詳細については、機器のマニュアルを参照してください。手順の安全性にご不明な点がある場合は、Thermo Scientific San Jose 製品のテクニカルサポートまでお問い合わせください。</p>	<p><b>普通危険:</b> 未归入其他类别的危险。此符号也会在仪器上出现。有关此危险的详细信息, 参阅适当的仪器手册。若对任何步骤的安全事项有疑问, 联系 Thermo Scientific San Jose 产品的技术支持中心。</p>

CAUTION Symbol	CAUTION	警告	危険警告
	<b>Laser hazard:</b> This instrument uses a laser that is capable of causing personal injury. This symbol also appears on the instrument. For details about the hazard, refer to the instrument manual.	<b>レーザー光線の危険性:</b> この機器では、身体傷害を引き起こすおそれのあるレーザーを使用しています。この標識記号は機器にも表示されています。この危険の詳細については、機器のマニュアルを参照してください。	<b>激光危险:</b> 本仪器所用激光会导致人身伤害。此符号也会在仪器上出现。有关此危险的详细信息, 参阅适当的仪器手册。
	<b>Ultra violet light hazard:</b> Do not look directly at the ultra-violet (UV) light or into the UV source. Exposure can cause eye damage. Wear UV eye protection.	<b>紫外光の危険性:</b> 紫外(UV)光またはUV光源を直接見ないでください。照射によって眼損傷を引き起こすおそれがあります。UV保護メガネを着用します。	<b>紫外光危険:</b> 不要直视紫外(UV)光或者紫外光源。直视可能导致眼睛伤害。佩戴紫外线防护眼镜。
	<b>Sharp object:</b> Avoid physical contact with the object.	<b>鋭利な物体:</b> 物体との身体的接触を避けてください。	<b>锋利物体:</b> 避免直接接触锋利的物体。
	<b>Pinch point:</b> Keep hands away from this area.	<b>ピンチポイント:</b> この部分には手を挟まれないようにしてください。	<b>夹点:</b> 勿将手放在此部位。
	<b>Heavy objects:</b> Never lift or move the instrument by yourself; you can suffer personal injury or damage the equipment. For specific lifting instructions, refer to the instrument manual.	<b>重量物:</b> 1人で機器を持ち上げたり移動しないでください。身体傷害を負ったり、機器を損傷するおそれがあります。具体的な持ち上げ方法については、機器のマニュアルを参照してください。	<b>重物:</b> 切勿独自提起或移动本仪器; 可能遭受人身伤害或损坏仪器。有关具体的提起说明, 参阅仪器手册。
	<b>Trip obstacle:</b> Be aware of cords, hoses, or other objects located on the floor.	<b>作業の障害物:</b> 床にあるコード、ホース、その他の物体に注意してください。	<b>绊倒危险:</b> 注意地面上的线、管或其他物品。
	When the safety of a procedure is questionable, contact Technical Support for Thermo Scientific San Jose products.	手順の安全性にご不明な点がある場合は、Thermo Scientific San Jose 製品のテクニカルサポートまでお問い合わせください。	如对安全程序有疑问, 联系 Thermo Scientific San Jose 产品的技术支持中心。

# Contents

	<b>Preface</b> .....	<b>xv</b>
	Related Documentation .....	xv
	Finding the Manuals .....	xvi
	Accessing the Data System Help for the Autosampler .....	xvii
	Safety and Special Notices .....	xviii
	Special Precautions .....	xix
	Good Laboratory Practices .....	xxii
	Contacting Us .....	xxiv
<b>Chapter 1</b>	<b>Introduction</b> .....	<b>1</b>
	Autosampler Components .....	2
	Tray Compartment .....	2
	Injection System .....	3
	Column Oven and Tray Compartment Heater and Cooler .....	15
	Status LEDs .....	16
	Injection Modes .....	17
	No Waste Injection .....	17
	Partial Loop Injection .....	18
	Full Loop Injection .....	19
	Injection Sequence .....	20
	Getting Ready for an Injection .....	22
	Drawing Transport Solvent (Partial Loop and No Waste Injections) .....	23
	Drawing Sample .....	24
	Pushing Transport Solvent (Partial Loop and No Waste Injections) .....	26
	Loading Sample into the Sample Loop .....	28
	Injecting Sample onto the Column .....	29
	Post-Injection Events .....	30
	Autosampler Operation .....	30
	Automated Sample Preparation .....	31
	Specifications .....	32
<b>Chapter 2</b>	<b>Installation</b> .....	<b>33</b>
	Software Compatibility .....	34
	Installation Checklist .....	34
	Unpacking and Inspecting the Instrument .....	35

	Making Initial Instrument Preparations . . . . .	35
	Making the Back Panel Connections . . . . .	36
	Connecting the System Interconnect Cable . . . . .	37
	Connecting the Ethernet Cable . . . . .	39
	Checking the Unit ID Settings . . . . .	39
	Connecting the Autosampler to Line Power . . . . .	39
	Connecting the Solvent Lines . . . . .	40
	Connecting the Wash Bottle . . . . .	41
	Connecting the Needle Tubing . . . . .	42
	Connecting the Autosampler to the LC Pump . . . . .	43
	Turning On the Autosampler . . . . .	46
	Calibrating the Accela Autosampler . . . . .	47
	Changing the Sample Loop . . . . .	48
<b>Chapter 3</b>	<b>Sample Loading . . . . .</b>	<b>49</b>
	Standard Tray Type . . . . .	49
	Installing the Standard Tray Type . . . . .	50
	Moving the XYZ Arm to the Back of the Tray Compartment . . . . .	51
	Carrier Trays for Microplates . . . . .	52
	Important Precautions for Sample Loading . . . . .	54
	Recommended Vials, Microplates, and Microplate Covers . . . . .	55
	Recommended Vials . . . . .	55
	Recommended Microplates . . . . .	55
	Recommended Microplate Covers . . . . .	56
<b>Chapter 4</b>	<b>Routine Maintenance . . . . .</b>	<b>59</b>
	Maintenance Schedule . . . . .	60
	Replacing the Rotor Seal in the Valco Injection Valve . . . . .	61
	Removing the Injection Valve from the Autosampler . . . . .	62
	Disassembling the Injection Valve . . . . .	64
	Cleaning the Stator . . . . .	65
	Installing a New Rotor Seal . . . . .	65
	Reinstalling the Injection Valve . . . . .	66
	Replacing the Inlet Filter for the Wash Bottle Solvent Line . . . . .	69
	Replacing the Transfer Tubing . . . . .	69
	Maintaining the Syringe Drive Assembly . . . . .	73
	Troubleshooting a Blockage in the Injection System . . . . .	77
	Testing the Needle Tubing and the Syringe Valve for Blockage . . . . .	79
	Testing the Needle for Blockage . . . . .	80
	Testing the Transfer Tube for Blockage . . . . .	81
	Cleaning the Injection Valve or the Sample Loop . . . . .	81

Replacing the Needle Tubing Assembly. . . . .	83
Setting the Needle to the Removal Position. . . . .	83
Removing the Needle Tubing Assembly . . . . .	84
Installing the Needle Tubing Assembly . . . . .	85
Setting the XYZ Arm to the Home Position . . . . .	89
Replacing the Needle Assembly . . . . .	90
Changing the Syringe or Replacing the Inner Plunger. . . . .	91
Setting the Syringe to the Removal Position . . . . .	91
Removing the Syringe from the Autosampler . . . . .	91
Replacing the Inner Plunger of the Syringe . . . . .	92
Installing the Syringe. . . . .	93
Setting the Syringe to the Home Position . . . . .	93
Clearing a Plugged Heat Exchanger. . . . .	94
Replacing a Fuse . . . . .	96
Maintenance Cycles. . . . .	97
Setting the Maintenance Cycles from the Xcalibur Data System . . . . .	97
Setting the Maintenance Cycles from the ChromQuest Data System . . . . .	98
<b>Chapter 5   Diagnostics. . . . .</b>	<b>101</b>
Power Up Diagnostics. . . . .	101
Error Log in the Xcalibur Data System . . . . .	104
Error Log in the ChromQuest Data System . . . . .	105
Autosampler Validation Information. . . . .	106
<b>Chapter 6   Routine Troubleshooting . . . . .</b>	<b>107</b>
General Chromatography Troubleshooting. . . . .	108
Autosampler-Specific Troubleshooting . . . . .	109
Chromatography Problems . . . . .	109
Hardware Problems. . . . .	113
Common Operator Errors. . . . .	117
Insufficient Wash Solvent . . . . .	117
Damaged Needle Tubing . . . . .	117
Incorrect Syringe Type . . . . .	117
Inappropriate Injection Volume . . . . .	118
Incorrect Dead Volume. . . . .	118
Overtightened Transfer Tube or Waste Tube Fittings. . . . .	118
Determining the Transfer Tubing Volume . . . . .	119
<b>Appendix A   Consumables and Service Parts. . . . .</b>	<b>123</b>
Consumables. . . . .	124
Service Parts . . . . .	125
Accela AS Accessory Kit. . . . .	126
Accela System Kit . . . . .	127

<b>Appendix B</b>	<b>Firmware Updates</b> .....	<b>129</b>
	Preparing the Autosampler for a Firmware Download .....	129
	Downloading Firmware to the Autosampler .....	131
<b>Appendix C</b>	<b>Quick Reference Guides</b> .....	<b>133</b>
	Replacing the Rotor Seal in the Rheodyne Valve .....	135
	Replacing the Rotor Seal in the Valco Valve .....	137
	Legacy Versions of the Accela Autosampler .....	139
	Using the Xcalibur Direct Control Commands .....	141
	Using the ChromQuest Direct Commands .....	143
	<b>Index</b> .....	<b>145</b>

# Preface

This manual describes the features, installation, and maintenance of the Accela™ Autosampler. This manual also describes portions of the Xcalibur™ or ChromQuest™ data systems required to perform diagnostics and maintenance procedures for the autosampler.

## Contents

- [Related Documentation](#)
- [Finding the Manuals](#)
- [Accessing the Data System Help for the Autosampler](#)
- [Safety and Special Notices](#)
- [Special Precautions](#)
- [Good Laboratory Practices](#)
- [Contacting Us](#)

## Related Documentation

In addition to this guide, Thermo Fisher Scientific provides the following documentation as PDF files for the Accela family of LC instruments:

- *Accela UHPLC Preinstallation Requirements Guide*
- *Accela UHPLC Getting Connected Guide*
- *Accela UHPLC User Guide for LC Devices* (previous title *Accela User Guide for the Xcalibur Data System*)
- *Accela UHPLC User Guide for the ChromQuest Data System*

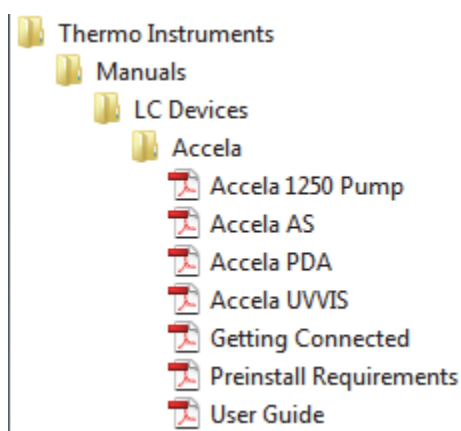
The Thermo Scientific™ data systems that support the Accela Autosampler also provide Help.

## Finding the Manuals

For the ChromQuest data system, you can find the manuals on the ChromQuest software installation CD.

For Thermo Scientific mass spectrometry applications, such as the Xcalibur data system, you can find the manuals (provided as PDF files) on the data system computer.

- To access the manuals from LC Devices 2.1.0 or 2.2.0, choose **Start > All Programs > Xcalibur > Manuals > LC Devices > Accela**.
- To access the manuals for LC Devices 2.2.1 or later, from the data system computer, choose **Start > All Programs > Thermo Instruments > Manuals > LC Devices > Accela**.



## Accessing the Data System Help for the Autosampler

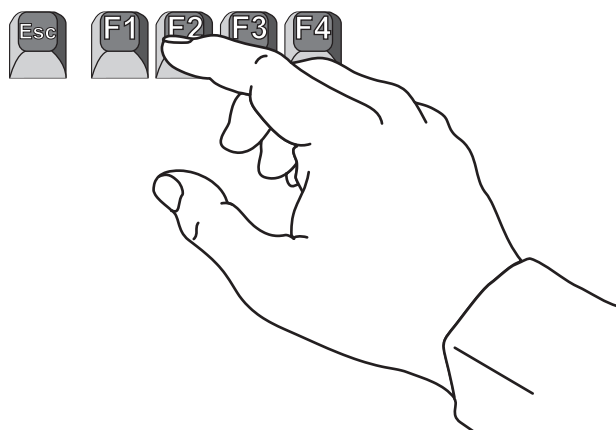
Your data system provides context-sensitive Help for these autosampler topics:


- Instrument configuration parameters for the autosampler
- Injection cycle and temperature control parameters for an acquisition method (instrument method in the Xcalibur data system or method in the ChromQuest data system)
- Calibration options for the autosampler
- Direct controls for the autosampler

### ❖ To open context-sensitive Help

Do one of the following:

- Press F1.



- Click the **Help** button, if available.
- For the ChromQuest data system, click the **Help** icon, .

## Safety and Special Notices

Make sure you follow the precautionary statements presented in this guide. The safety and other special notices appear in boxes.

Safety and special notices include the following:



**CAUTION** Highlights hazards to humans, property, or the environment. Each CAUTION notice is accompanied by an appropriate CAUTION symbol.



**CAUTION** Alerts you to the presence of high voltage and to the potential injury that could occur from electrical shock were you to come in contact with a specific instrument area or component. It also tells you how to avoid contact with the high-voltage areas in your instrument.



**CAUTION** Alerts you to the presence of hot surfaces and to the potential injury that could occur were you to come in contact with a specific instrument area.



**CAUTION** Highlights a heavy lifting hazard.



**CAUTION** Highlights a potential chemical hazard. Wear the appropriate safety gloves when handling toxic, carcinogenic, mutagenic, or corrosive or irritant chemicals.

**IMPORTANT** Highlights information necessary to prevent damage to software, loss of data, or invalid test results; or might contain information that is critical for optimal performance of the system.

**Note** Highlights information of general interest.

**Tip** Highlights helpful information that can make a task easier.

## Special Precautions

Follow these precautions when handling the autosampler:

- [Loading the Autosampler Tray Compartment](#)
- [Connecting the Waste Line](#)
- [Lifting and Carrying the Autosampler](#)
- [Avoiding Contact with Hot Surfaces](#)

### Loading the Autosampler Tray Compartment

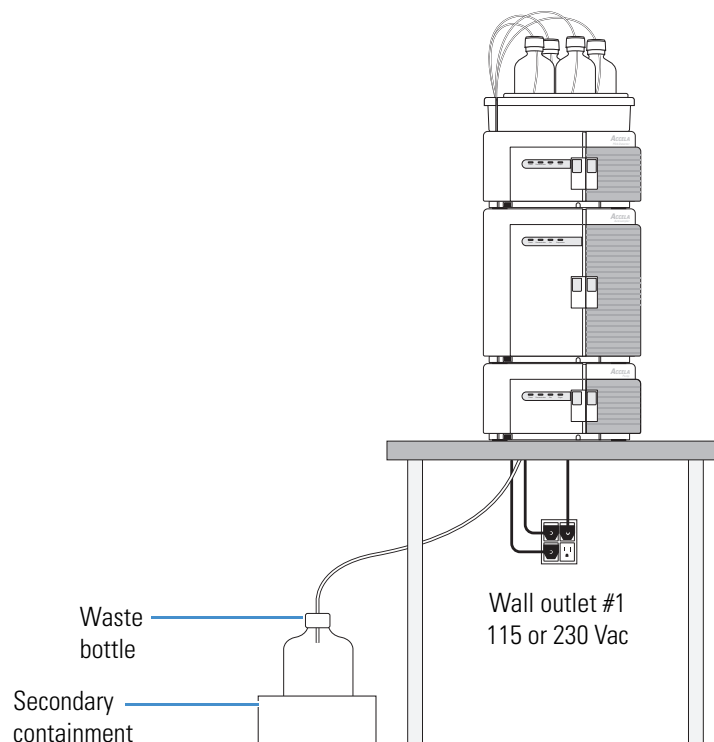
Do not place tall objects taller than 4.6 cm (1.8 in.) in the tray compartment. Placing tall objects in the tray compartment can damage the autosampler arm as it moves within the tray compartment to the sample vial and well locations specified in the injection sequence.



**CAUTION** Placing tall objects in the tray compartment can damage the autosampler's XYZ arm.

### Connecting the Waste Line

Ensure that the waste line connected to the drainage manifold is routed to a waste bottle as shown below.



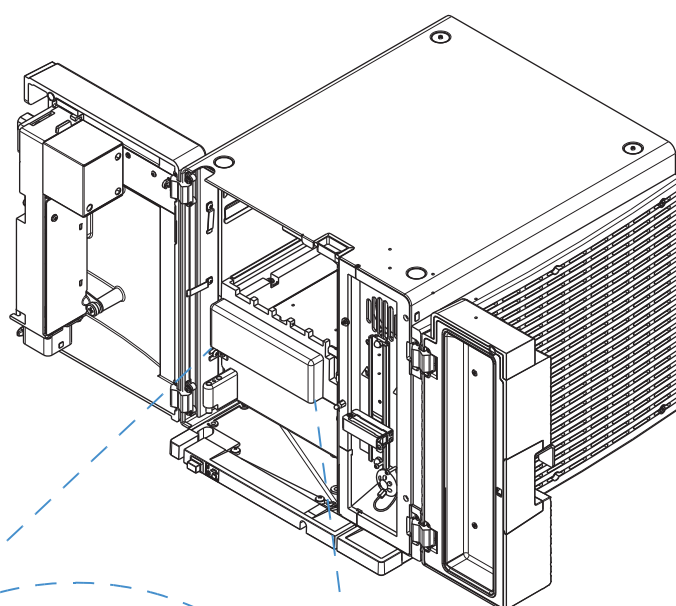
## Lifting and Carrying the Autosampler

The autosampler, at 30 kg (66 lb) and with a height, width, and depth of 37 × 38 × 51 cm (14.5 × 15 × 20 in.), is too heavy and too bulky for one person alone to handle safely. In addition, any jarring or uneven movement can cause misalignment of the autosampler's XYZ arm.



**CAUTION** For your safety and to avoid instrument damage, take care when handling the autosampler. Lifting or moving the autosampler requires a team effort.

**Accela Autosampler**

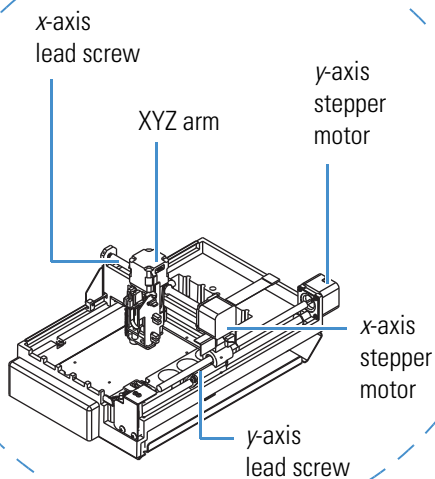


z-axis  
height  
37 cm  
(14.5 in.)

x-axis  
width  
38 cm  
(15 in.)

y-axis  
depth  
51 cm  
(20 in.)

**View of the XYZ arm**

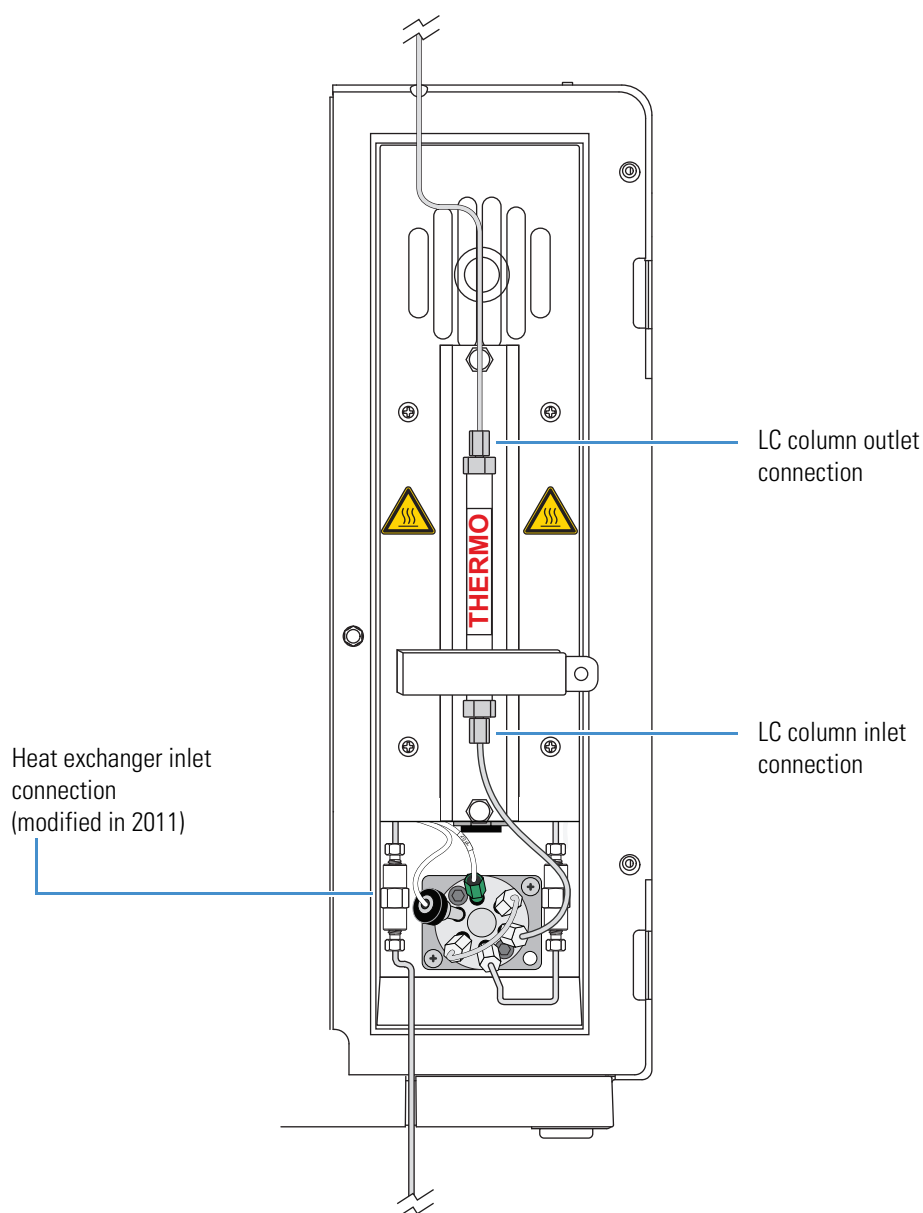


## Avoiding Contact with Hot Surfaces

The autosampler has two controlled temperature zones: the tray compartment and the column oven compartment. Because the column oven can reach temperatures as high as 95 °C (203 °F), ensure that the oven is at room temperature before installing or removing the LC column and before connecting the pump outlet to the inlet of the autosampler heat exchanger.



**CAUTION** To prevent personal injury, before installing the LC column or connecting the pump to the autosampler, make sure that the column oven compartment is at room temperature.



## Good Laboratory Practices

To obtain optimal performance from your LC system and to prevent personal injury or injury to the environment, do the following:

- Keep good records.
- Read the manufacturers' Material Safety Data Sheets (MSDSs) for the chemicals being used in your laboratory.
- Remove particulate matter from your samples before you inject them into the liquid chromatograph.
- Use HPLC-grade solvents.
- Connect the drainage tubes from the pump, autosampler, and detector to an appropriate waste receptacle. Dispose of solvents as specified by local regulations.

## Keep Good Records

To help identify and isolate problems with either your equipment or your methodology, for best results, keep good records of all system conditions (for example, % RSDs on retention times and peak areas, and peak shape and resolution). At a minimum, keep a chromatogram of a typical sample and standard mixture, well documented with system conditions, for future reference. Careful comparison of retention times, peak shapes, peak sensitivity, and baseline noise can provide valuable clues to identifying and solving future problems.

## Chemical Toxicity

Although the large volume of toxic and flammable solvents used and stored in laboratories can be quite dangerous, do not ignore the potential hazards posed by your samples. Take special care to read and follow all precautions that ensure proper ventilation, storage, handling, and disposal of both solvents and samples. Become familiar with the toxicity data and potential hazards associated with all chemicals by referring to the manufacturers' Material Safety Data Sheets.

## Sample Preparation

Always consider the solubility of your sample in the solvent/mobile phase. Sample precipitation can plug the column, tubing, or flow cell causing flow restriction. This obstruction can result in irreparable damage to the system. You can remove particulate matter by filtering the samples through 0.45 or 0.2  $\mu\text{m}$  (or less) filters.

## Solvent Requirements

Many chemical manufacturers provide a line of high-purity or HPLC-grade reagents that are free of chemical impurities. Typically, HPLC-grade solvents do not require filtration. You can significantly prolong the life and effectiveness of the inlet filters, check valves and seals, injector, and column by routine filtration of other types of solvents through a 0.45 or 0.2  $\mu\text{m}$  (or less) fluorocarbon filter before placing them in the solvent reservoir bottles.

Choose a mobile phase that is compatible with the sample and column you have selected for your separation. Remember that some solvents are corrosive to stainless steel.

## Solvent Disposal

Make sure you have a solvent waste container or other kind of drain system available at or below the benchtop level. Most solvents have special disposal requirements and should not be disposed of directly down a drain. Follow all governmental regulations when disposing of any chemical.

## High-Pressure Systems and Leaks

LC systems operate at high pressures. Because liquids are not highly compressible, they do not store much energy. Accordingly, the high pressures in an LC system pose little immediate danger. However, correct any leak that occurs as soon as possible. Always wear eye and skin protection when operating or maintaining an LC system. Always shut down the system and return it to atmospheric pressure before attempting any maintenance.

## Contacting Us

There are several ways to contact Thermo Fisher Scientific for the information you need.

❖ **To contact Technical Support**

Phone	800-532-4752
Fax	561-688-8736
E-mail	<a href="mailto:us.techsupport.analyze@thermofisher.com">us.techsupport.analyze@thermofisher.com</a>
Knowledge base	<a href="http://www.thermokb.com">www.thermokb.com</a>

Find software updates and utilities to download at [mssupport.thermo.com](http://mssupport.thermo.com).

❖ **To contact Customer Service for ordering information**

Phone	800-532-4752
Fax	561-688-8731
E-mail	<a href="mailto:us.customer-support.analyze@thermofisher.com">us.customer-support.analyze@thermofisher.com</a>

❖ **To get local contact information for sales or service**

Go to <http://www.thermoscientific.com/en/support-landing/support.html>.

❖ **To copy manuals from the Internet**

Go to [mssupport.thermo.com](http://mssupport.thermo.com), agree to the Terms and Conditions, and then click **Customer Manuals** in the left margin of the window.

❖ **To suggest changes to documentation or to Help**

- Fill out a reader survey online at [www.surveymonkey.com/s/PQM6P62](http://www.surveymonkey.com/s/PQM6P62)

–or–

Click the link below.



- Send an e-mail message to the Technical Publications Editor at [techpubs-lcms@thermofisher.com](mailto:techpubs-lcms@thermofisher.com).

## Introduction

The Accela Autosampler is a member of the Accela family of ultra-high-performance liquid chromatography (UHPLC) instruments. The Accela Autosampler (see [Figure 1](#)) holds up to 200 standard vials, three 96-well microplates, or three 384-well microplates; contains a built-in column oven (5 to 95 °C); provides sample temperature control (0 to 60 °C); and can perform automated sample preparation routines.

### Contents

- [Autosampler Components](#)
- [Status LEDs](#)
- [Injection Modes](#)
- [Injection Sequence](#)
- [Autosampler Operation](#)
- [Automated Sample Preparation](#)
- [Specifications](#)

**Figure 1.** Accela Autosampler



## Autosampler Components

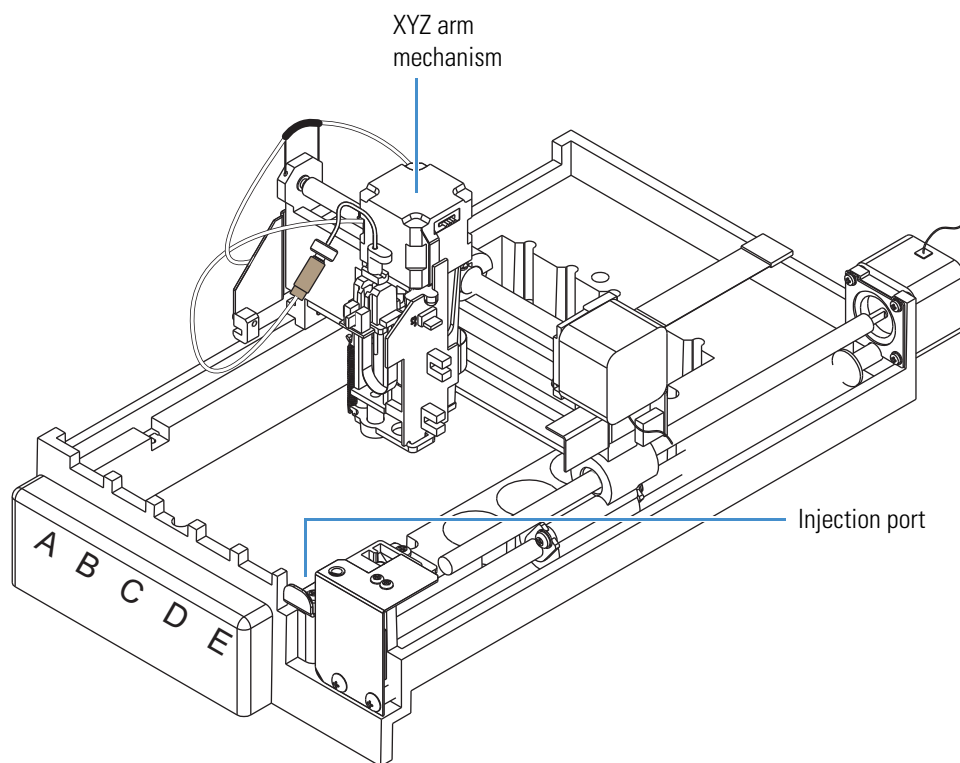
The main components of the Accela Autosampler are as follows:

- Tray Compartment
- Injection System
- Column Oven and Tray Compartment Heater and Cooler

### Tray Compartment

Two types of sample trays are supplied with the Accela Autosampler: a conventional sample tray and a microwell carrier. The tray compartment can hold up to five conventional sample trays or one microwell carrier. The tray compartment also holds up to four 16 mL capacity reservoir vials that can hold solvent, reagent, or diluent. The reservoir vials are located behind the wash station and are designated RV1, RV2, RV3, and RV4. [Figure 2](#) shows an empty tray compartment.

**Figure 2.** Tray compartment



From the left to the right side of the tray compartment, the five conventional sample trays are designated A, B, C, D, and E. Each conventional sample tray holds up to 40 standard 1.8 mL vials for a total capacity of 200 samples. Overlays allow the sample trays to accommodate different vial sizes.

The microwell carrier can hold up to three low-density microplates or up to three high-density microplates. From the front to the back of the tray compartment, the microplates are designated A, B, and C.

The low-density microplate contains 96 wells in an 8 × 12 configuration, designated A1 through H12, for a total capacity of 288 samples. Each well can hold up to 250 µL of sample.

The high-density microplate contains 384 wells in a 16 × 24 configuration, designated A1 through P24, for a total capacity of 1152 samples. Each well can hold up to 50 µL of sample.

The tray compartment door contains a magnetic switch. The magnet is located in the door and the switch is attached to the chassis. When you open the door, the switch signals the autosampler that the door is open. If you turn on the verification option for the door position when you configure the autosampler, the XYZ arm automatically moves to the back of the tray compartment when you open the door so that you can remove trays or replace vials.

Opening the tray compartment door while the autosampler is making an injection does not interrupt the current run. The XYZ arm moves to the back of the compartment after the injection is complete and the sequence pauses. Closing the autosampler door allows the sequence to resume.

## Injection System

Figure 3 shows the injection system of the Accela Autosampler. The major components of the injection system are as follows:

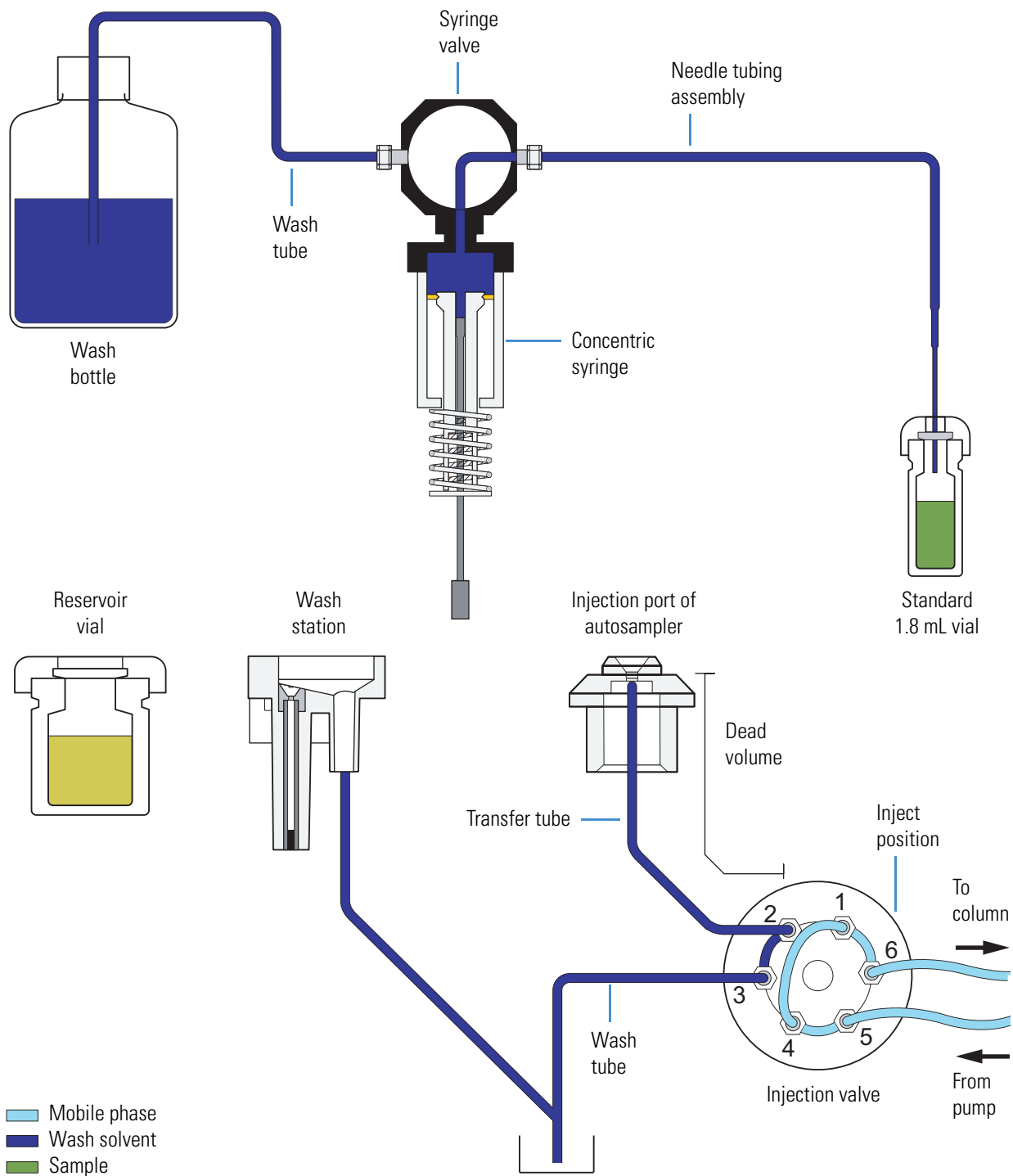
- Wash Bottle and Wash Bottle Tube
- XYZ Arm Mechanism
- Needle Tubing Assembly and Needle Assembly
- Syringe Valve
- Syringe
- Wash Station
- Injection Port of the Autosampler and Transfer Tube
- Injection Valve
- Sample Loop

You can order the replaceable components of the injection system by Thermo Scientific part number. “Consumables” on page 124 lists the part numbers.



**CAUTION** Because the XYZ arm moves to the sample position, do not place objects taller than 4.5 cm (1.8 in.) in the tray compartment.

Figure 3. Accela Autosampler injection components



## Wash Bottle and Wash Bottle Tube

The wash bottle rests in the solvent platform on the top of the Accela stack. The wash bottle tube connects the wash bottle to the syringe valve. Both of the direct commands, Flush (from bottle) and Wash Needle (from bottle), draw solvent from the wash bottle. If you let the wash bottle run dry, the syringe barrel and the wash bottle tube fill with air. When this happens, the autosampler cannot draw sample into the needle tubing during an injection sequence.

**IMPORTANT** Check the volume of solvent in the wash bottle before performing a sequence of injections. Letting the wash bottle run dry compromises the performance of the autosampler.

## XYZ Arm Mechanism

The XYZ arm mechanism moves the needle along the X-Y plane to the requested vial or well location. After it positions the needle above the vial or well, the XYZ arm lowers the needle along the z axis to the requested needle height. The syringe plunger descends, drawing sample into the needle tubing. The XYZ arm mechanism moves back to the home position, above the injection port of the autosampler, and then lowers the needle into the injection port. The syringe plunger ascends, expelling the sample from the needle tubing.

Do not move the XYZ arm manually. Instead, use the commands and options listed in [Table 1](#) to control the position of the XYZ arm. For information on using the data system commands, see [“Using the Xcalibur Direct Control Commands”](#) on page 141 or [“Using the ChromQuest Direct Commands”](#) on page 143.

**Table 1.** Commands and options that control the position of the XYZ arm

Action	Data system	Command or option
Make the XYZ arm automatically move to the back of the tray compartment when you open the tray door.	Xcalibur	Select the <b>Verify Door Is Closed</b> check box when you specify the instrument configuration options.
	ChromQuest	Select the <b>Verify Door Is Closed</b> check box when you specify the instrument configuration options.
Move the XYZ arm to the back of the tray compartment.	Xcalibur	Use the <b>Position Arm to Access Tray</b> direct command.
	ChromQuest	Use the <b>Position Arm to Access Tray</b> direct control command.
Move the XYZ arm to its home position above the injection port and behind the wash station.	Xcalibur	Use the <b>Set Arm to Home Position</b> direct command.
	ChromQuest	Use the <b>Go to Home</b> direct control command.
Move the XYZ arm to the center front of the tray compartment, allowing easy access to the needle.	Xcalibur	Use the <b>Remove Needle</b> direct command.
	ChromQuest	Use the <b>Needle Removal</b> direct control command.

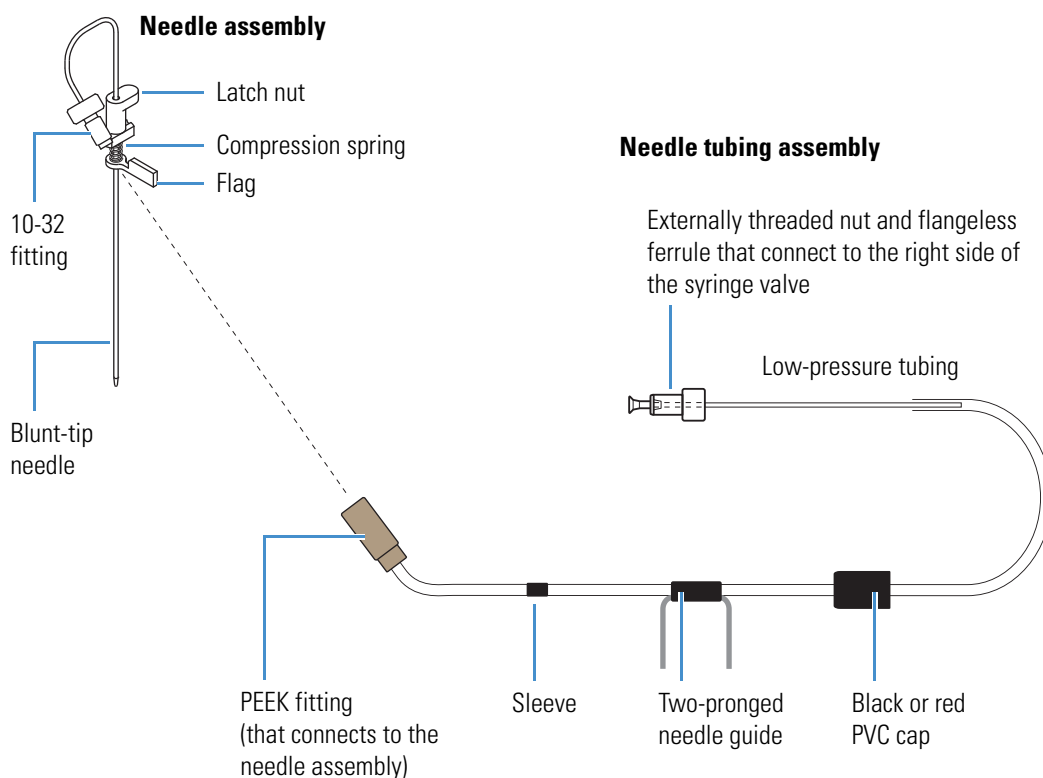
## Needle Tubing Assembly and Needle Assembly

Figure 4 shows the needle assembly and the needle tubing assembly.

The needle assembly consists of a blunt-tip needle, a latch nut, a flag, a compression spring, and an externally threaded fitting that connects to the needle tube assembly.

The needle tube assembly connects the solvent path between the needle and the syringe valve and consists of low-pressure tubing, an internally threaded fitting that connects to the needle assembly fitting, a sleeve, a black or red PVC cap, a needle tube guide that attaches to the *x*-axis positioning frame, and an externally threaded fitting with a flangeless ferrule that connects to the right side of the syringe valve.

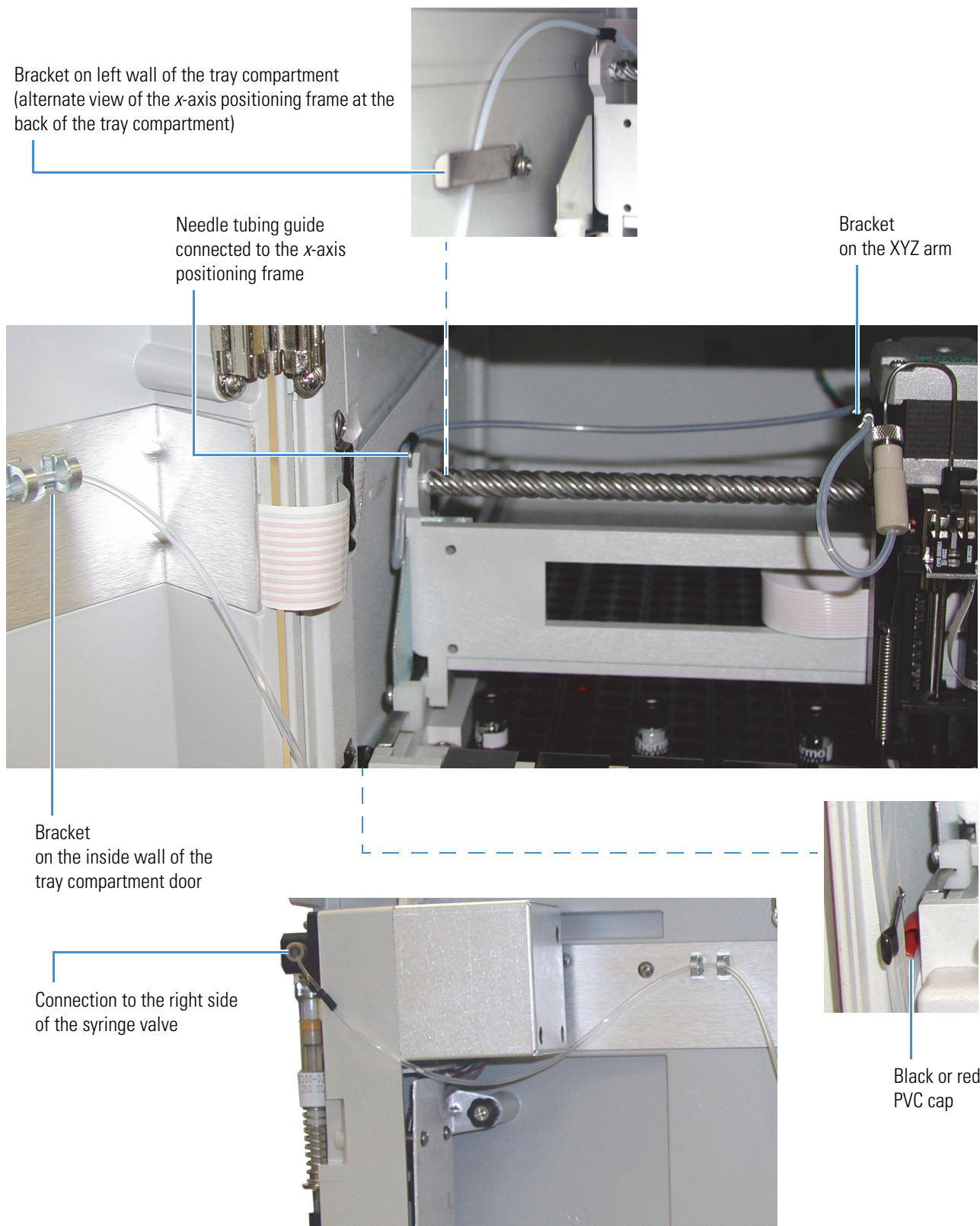
**Figure 4.** Needle assembly and needle tubing assembly



The needle mount on the XYZ arm holds the needle assembly. To prevent the needle tubing from interfering with the movement of the XYZ arm, the following items secure the needle tubing to the autosampler (see Figure 5):

- A bracket on the XYZ arm
- A guide on the *x*-axis positioning frame
- A bracket on the left wall of the tray compartment
- A PVC cap that holds the tubing below the metal runner for the *x*-axis positioning frame
- A bracket on the inner wall of the tray compartment door

Figure 5. Needle tubing assembly connections



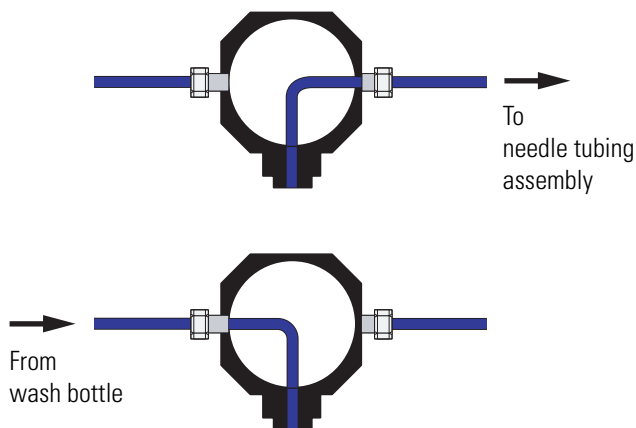
The standard needle tubing assembly holds approximately 560  $\mu\text{L}$  of liquid. During an injection, the syringe draws sample into the needle tubing, not into the syringe barrel. If your autosampler is configured with a 2500  $\mu\text{L}$  standard syringe, and you want to make partial loop injections greater than 500  $\mu\text{L}$  or full loop injections greater than 150  $\mu\text{L}$ , you must add additional needle tubing to your autosampler.

The tubing extension, which the autosampler needs to make large volume injections, holds up to 1 mL of liquid. Adding this additional tubing to your autosampler allows the withdrawal of up to 1500  $\mu\text{L}$  from a sample location or a reservoir vial. To attach this additional tubing to your autosampler, detach the needle tubing assembly from the syringe valve. Use the Teflon™ connector to attach the additional tubing to the needle tubing assembly. Attach the other end of the additional tubing to the syringe valve.

## Syringe Valve

The syringe valve is a 2-position rotary valve (see [Figure 6](#)). In the wash bottle position, the downward movement of the syringe plunger draws wash solvent from the wash bottle into the syringe barrel. In the needle position, the downward movement of the syringe plunger draws liquid from a sample vial or a reservoir vial into the needle tubing. As the syringe plunger moves upward, it pushes liquid out of the needle tubing.

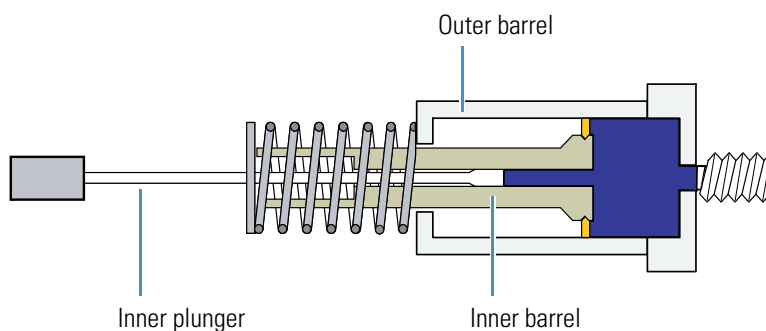
**Figure 6.** Two-position rotary syringe valve



## Syringe

The Accela Autosampler uses a syringe with two concentric barrels to perform liquid transfers (see [Figure 7](#)). The autosampler uses the inner barrel plunger to draw and deliver sample amounts equal to or less than the nominal size of the syringe and the outer barrel plunger to draw and expel volumes up to 560  $\mu\text{L}$ .

**Figure 7.** Dual concentric syringe



The inner plunger wears more rapidly than the rest of the syringe. The lifespan of the inner plunger is approximately 50000 injections. Replace the inner plunger if you notice liquid leaking from the bottom of the syringe. For ordering information, see [page 124](#).

Dual concentric syringes are available in 100, 250, and 500  $\mu\text{L}$  sizes. In addition, a 2500  $\mu\text{L}$  standard syringe is available. The size of the syringe determines the injection volume range. [Table 2](#) lists the minimum and maximum injection volumes for each syringe size.

**Table 2.** Allowable injection volumes based on the syringe size

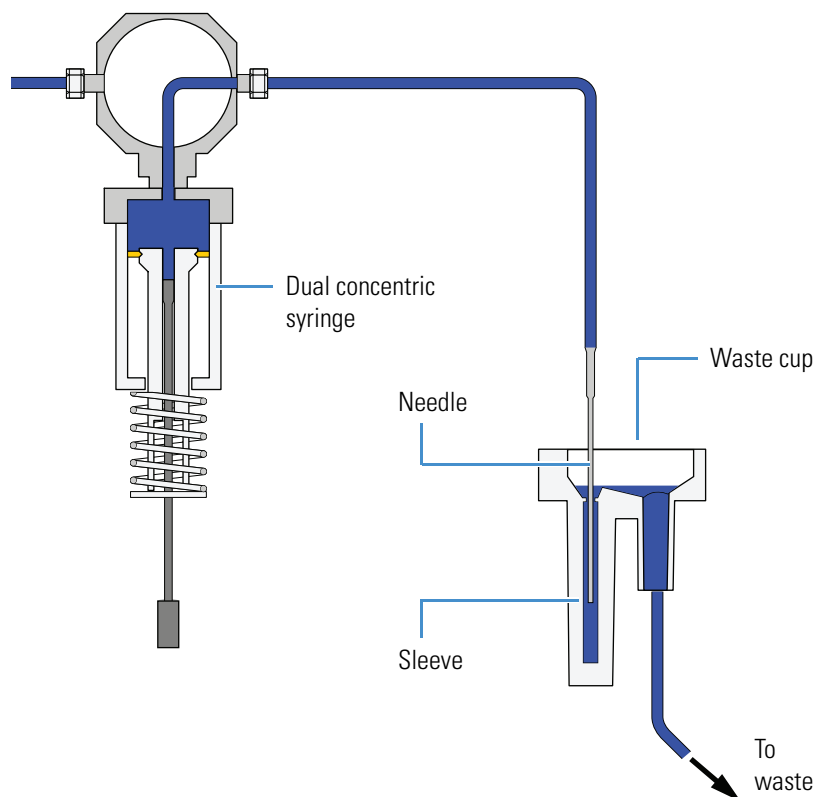
Syringe size ( $\mu\text{L}$ )	Injection volume ( $\mu\text{L}$ )			
	Minimum	Maximum (No waste)	Maximum (Partial loop)	Maximum (Full loop)
100	0.1	20	20	20
250	0.1	100	100	100
500	0.1	250	250	250
2500	0.1	1000	1000	1000 <sup>a</sup>

<sup>a</sup> Requires an extension to the standard needle tubing.

## Wash Station

The wash station is a waste cup containing an inner sleeve slightly larger than the needle (see Figure 8). Low-pressure tubing connects the waste cup to the waste bottle. To wash the outside of the needle, the XYZ arm moves the needle to the wash station and lowers the needle into the inner sleeve of the waste cup. The syringe draws solvent from the wash bottle or requested reservoir vial, and then expels the solvent through the needle. As it fills the waste cup, the expelled solvent flows up over the exterior surface of the needle, and then out the waste tubing to the waste bottle.

**Figure 8.** Wash station



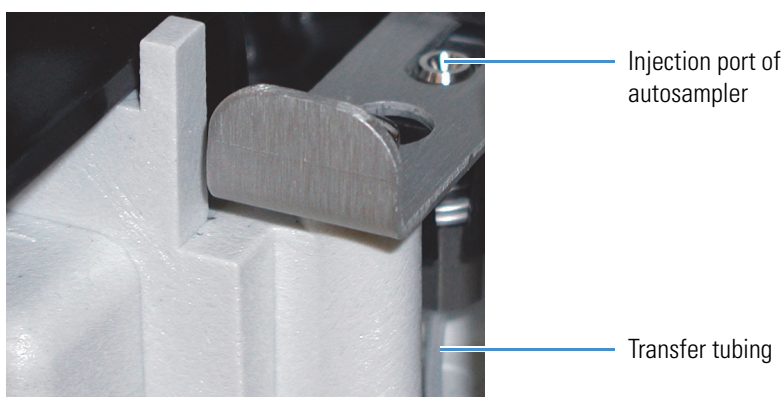
## Injection Port of the Autosampler and Transfer Tube

A transfer tube connects the injection port (see [Figure 9](#)) to the injection valve (see [Figure 10](#)). The transfer tubing has an inner diameter of 0.012 in. One end of the tubing has a flanged stainless steel fitting that connects to the injection port. The other end of the tubing has a PEEK™ fitting that connects to port 2 of the injection valve (see [Figure 11](#)).

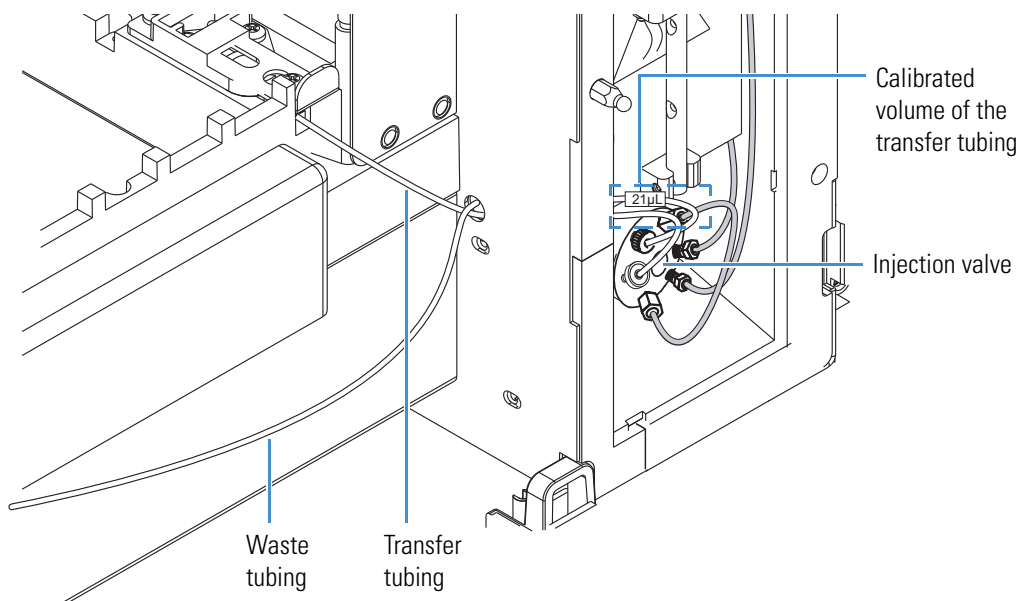
### IMPORTANT

1. The label attached to the transfer tube assembly specifies the internal volume of the tubing. Because the autosampler uses this value for its injection algorithm, you must type this value in the Dead Volume box when you configure the Accela Autosampler. If you do not enter the value listed on the label, your data might be compromised.
2. You can constrict the transfer tube by overtightening the fitting to port 2 of the injection valve. Lack of injection precision is a symptom of a constricted transfer tube.

**Figure 9.** Injection port of the Accela Autosampler



**Figure 10.** Transfer tubing connections

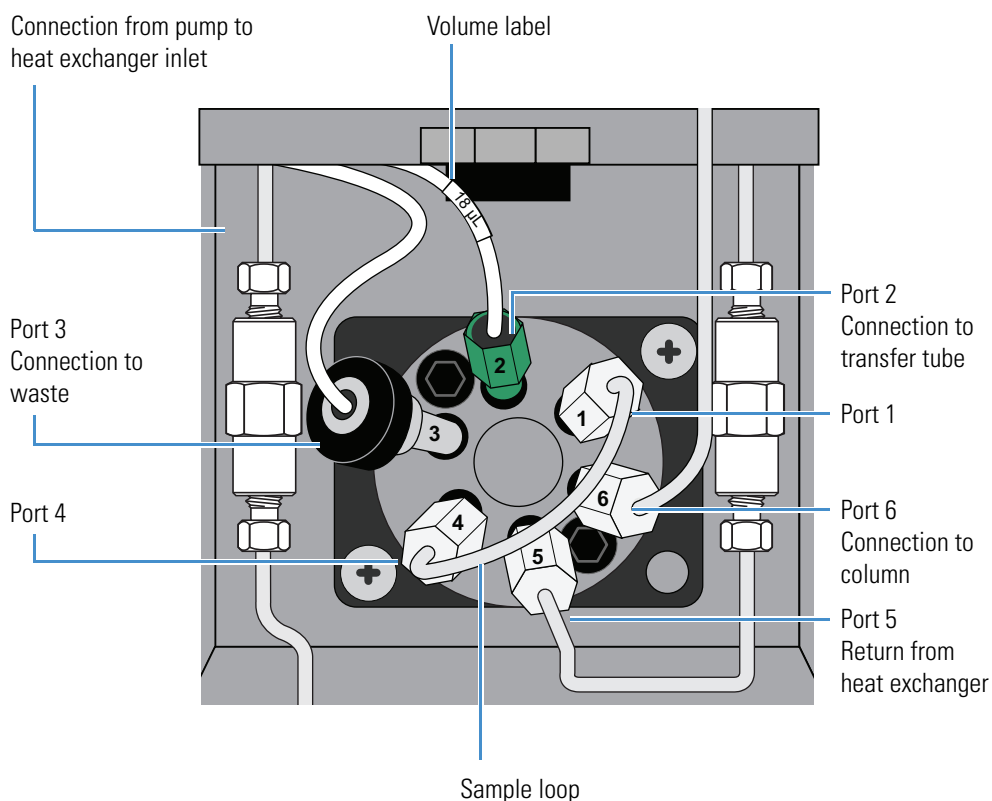


## Injection Valve

The injection valve is a six-port, two-position valve that introduces sample onto the column by way of the sample loop (see Figure 11).

**Note** Figure 11 shows the plumbing connections to the current heat exchanger. For information about the plumbing connections to the original heat exchanger, see “Legacy Versions of the Accela Autosampler” on page 139.

**Figure 11.** Six-port rotary injection valve



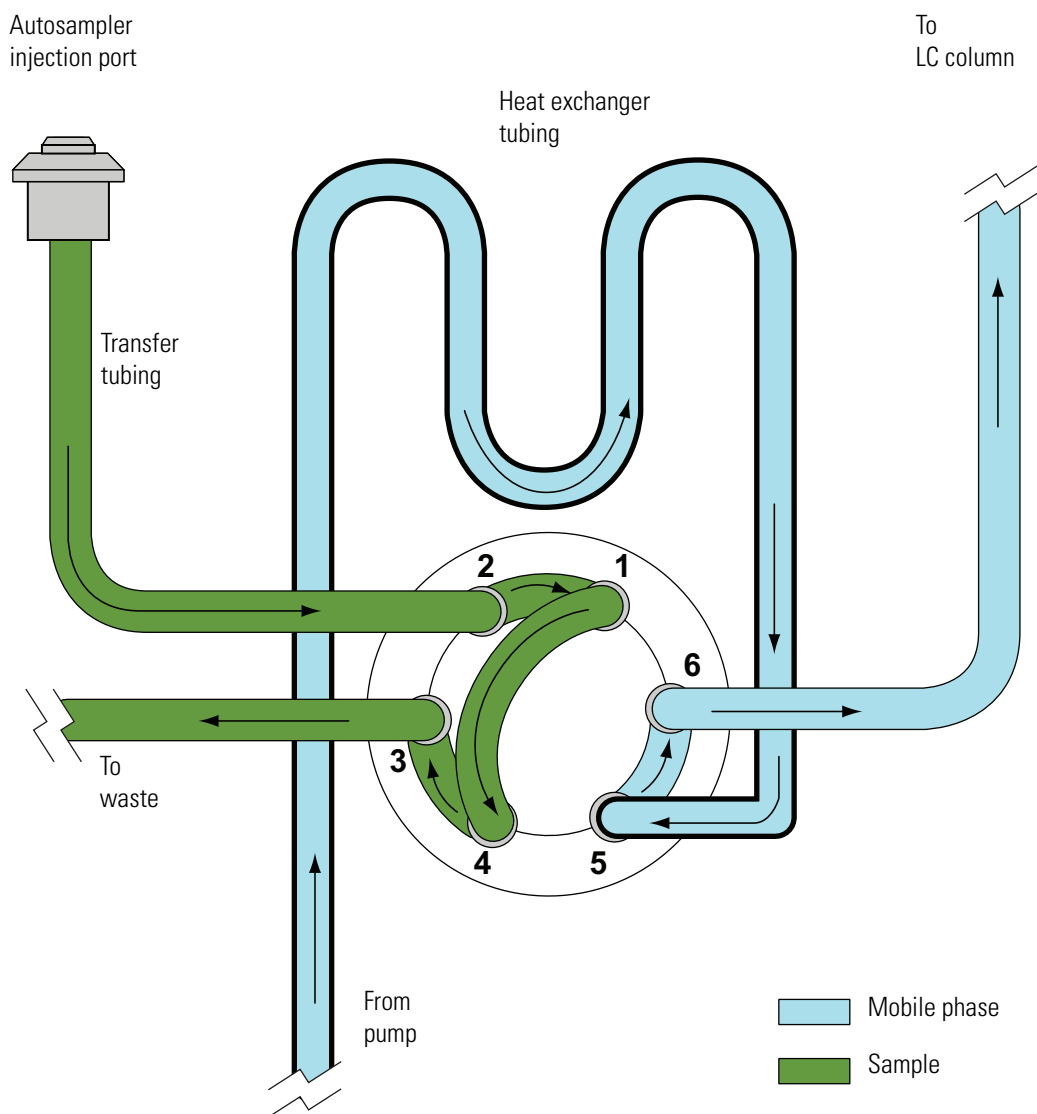
There are two positions for the injection valve: fill (load) and inject. Three passages are open in each position.

In the fill (load) position (see Figure 12), the three passages connect the following ports:

- The injection port of the injection valve (port 2) is connected to the front of the sample loop (port 1).
- The back of the sample loop (port 4) is connected to the waste line (port 3).
- The temperature-equilibrated mobile phase that has passed through the heat exchanger (port 5) is connected to the LC column (port 6).

To isolate the sample loop from the mobile phase stream, the autosampler rotates the valve to the load position (see Figure 12). While the mobile phase stream bypasses the loop, the syringe pushes sample through the transfer tubing and into the front of the sample loop. As the sample loop fills with sample, excess solution passes out of the back of the sample loop to waste.

**Figure 12.** Fill (load) position for the six-port injection valve

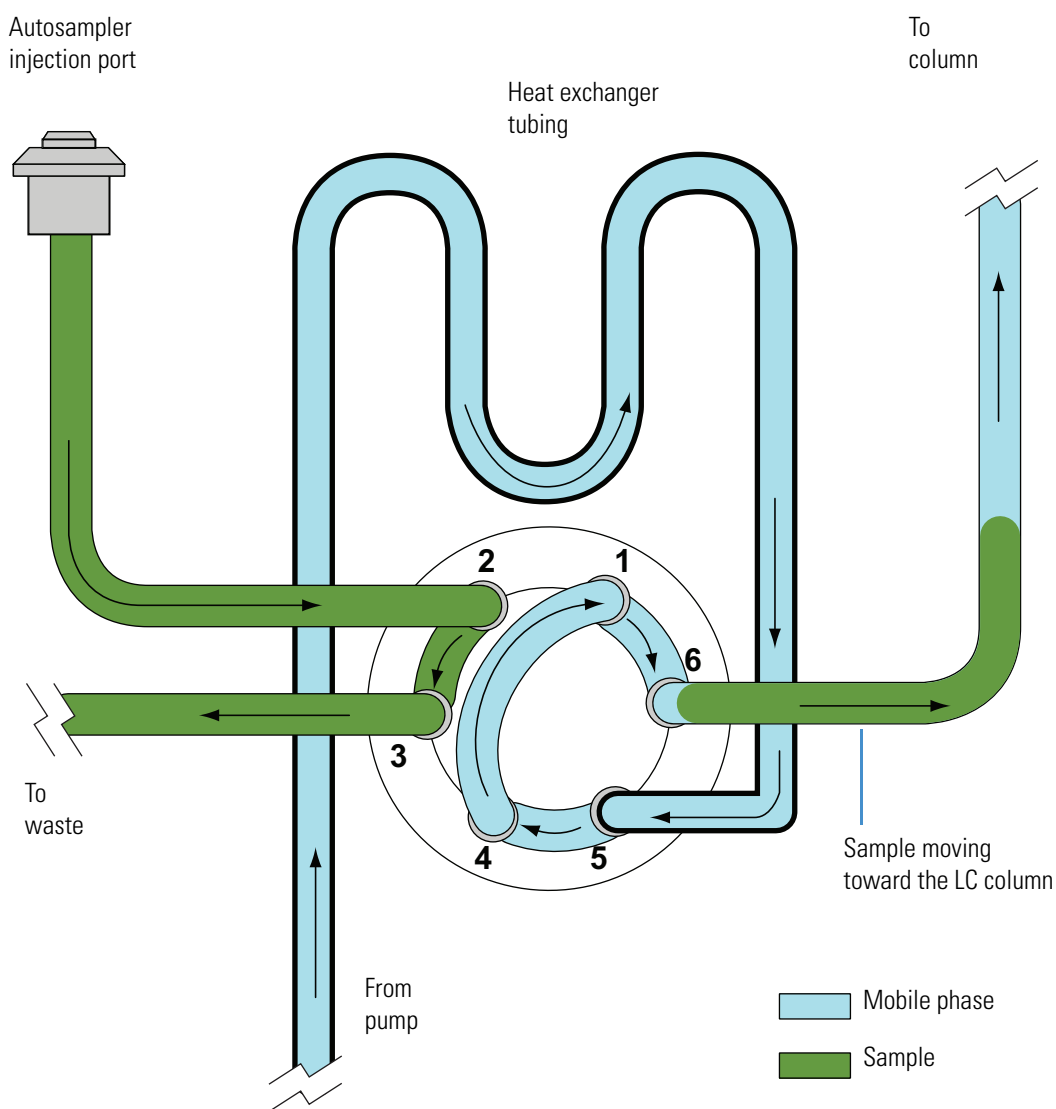


In the inject position (see Figure 13), the three passages connect the following ports:

- The solvent return from the heat exchanger (port 5) is connected to the back of the loop (port 4).
- The front of the sample loop (port 1) is connected to the column inlet (port 6).
- The injection port of the injection valve (port 2) is connected to the waste line (port 3).

To put the sample loop into the path of the mobile phase stream, the autosampler rotates the valve to the inject position (see Figure 13). The mobile phase stream enters the sample loop from the back, backflushing the contents of the sample loop onto the column. Excess sample left in the transfer tube passes directly to waste. To provide ample rinsing of the sample loop with mobile phase, the injection valve remains in the inject position during the entire run.

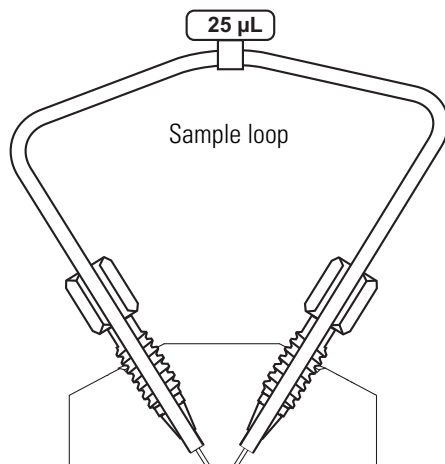
**Figure 13.** Inject position for the six-port injection valve



## Sample Loop

The sample loop is a stainless steel tube with end fittings that holds the sample prior to its introduction onto the column. The sample loop is an interchangeable part swaged onto ports 1 and 4 of the six-port injection valve (see [Figure 14](#)).

**Figure 14.** Schematic of the sample loop attached to the injection valve



Thermo Fisher Scientific ships the Accela Autosampler with a 25 µL sample loop. Sample loops are available in nominal sizes ranging from 5 to 1000 µL. The accuracy of the sample loop volume is  $\pm 20\%$ . This means that the actual volume of a 25 µL sample loop is between 20 to 30 µL. For ordering information, see [“Consumables”](#) on [page 124](#).

## Column Oven and Tray Compartment Heater and Cooler

The built-in column oven controls the temperature of the air surrounding the chromatographic column. Isothermal temperature control is achieved with a Peltier device. The Peltier device is a solid-state, heat-transferring assembly used to heat or cool the column oven. The temperature control range is 5 to 95 °C.

Between the pump outlet and the autosampler injection valve, the mobile phase passes through a heat exchanger that is located behind the column oven plate. As the mobile phase passes through the heat exchanger, it equilibrates to the temperature of the column oven. The heat exchanger consists of a length of 0.004 in. ID tubing that adds only 3 µL of gradient delay volume to the system (see [Figure 72](#) on [page 94](#)).

The tray temperature control feature provides temperature control of the samples in the range from 0 to 60 °C. A Peltier device maintains the tray temperature.

## Status LEDs

Four status light-emitting diodes (LEDs) labeled Power, Communication, Run, and Temperature are located on the front of the autosampler's tray compartment door (see Figure 15). Table 3 lists the states of the LEDs.

**Figure 15.** Status LEDs



**Note** To control the temperature of the column oven compartment and the tray compartment, select the Wait for Temperature Ready check box when you add the Accela Autosampler to the data system instrument configuration.

**Table 3.** Status LED states

LED	State	Meaning
<b>Power</b>	Green	The autosampler power is on.
<b>Comm</b>	Amber	Communication with the data system has not been established.
	Green	Communication with the data system has been established.
<b>Run</b>	Flashing Amber	An error condition, such as an XYZ arm jam or initialization startup error, has occurred.
	Green	The autosampler is in the Ready state.
	Flashing Green	An injection or timed event is in progress.
<b>Temp<sup>a</sup></b>	Amber	A temperature change within the column oven or tray temperature zones is in progress.
	Green	The column oven and tray temperature zones are in equilibrium at the set temperature.

<sup>a</sup> The Temp LED remains green if you do not select the Wait for Temperature Ready check box when you add the Accela Autosampler to the instrument configuration.

## Injection Modes

The Accela Autosampler can perform the following injection modes:

- [No Waste Injection](#)
- [Partial Loop Injection](#)
- [Full Loop Injection](#)

The optimum injection mode depends on the amount of sample that you have and the degree of precision that your application requires.

### No Waste Injection

In the no waste injection mode, the autosampler withdraws only the exact amount of sample requested from the sample vial. Of the three injection modes, the no waste injection mode uses the least amount of sample, but it is also the least precise. Use this injection mode to conserve sample.

**IMPORTANT** For no waste injections, do the following:

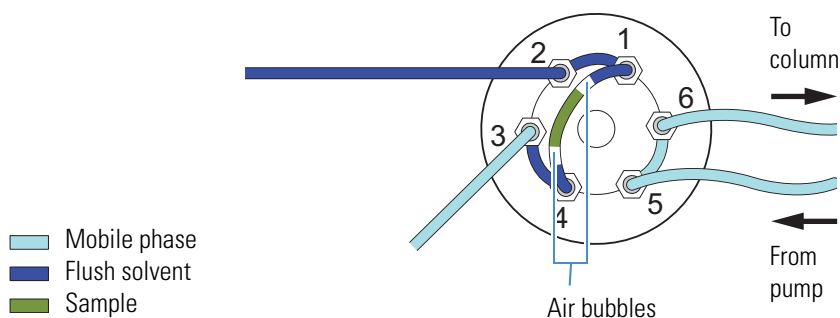
- Use a sample loop that is at least 5  $\mu\text{L}$  larger than the injection volume. Because the accuracy of the nominal size is  $\pm 20\%$ , use an estimate of 80% for the actual size. For example, use 20  $\mu\text{L}$  as an estimate for the actual volume of a 25  $\mu\text{L}$  loop, and inject no more than 15  $\mu\text{L}$  with this loop size.
- Consider matching the chemistry of the sample matrix, the flush solution, and the mobile phase. For no waste injections, the autosampler loads approximately 2  $\mu\text{L}$  of flush solvent and 3  $\mu\text{L}$  of air into the sample loop (see [Figure 16](#)), regardless of the requested injection volume.
- Inject at least 1.0  $\mu\text{L}$  of sample.

Approximately 0.25  $\mu\text{L}$  of the sample is lost as it travels from the injection port through the transfer tubing and into the injection valve. Because of this loss, inject at least 1.0  $\mu\text{L}$  of sample with the no waste injection mode.

The quantity of lost sample depends on the syringe rate. Decreasing the syringe rate decreases the sample loss. Thermo Fisher Scientific recommends a syringe rate no greater than 4  $\mu\text{L}/\text{s}$  for the no waste injection mode.

In addition to the sample, the no waste injection mode loads approximately 2  $\mu\text{L}$  of flush solvent and 3  $\mu\text{L}$  of air into the sample loop (see [Figure 16](#)). Because these values are independent of the injection volume, the chemistry of the flush solution can affect your chromatographic results. For best chromatographic results, consider matching the chemistry of the sample matrix, the flush solution, and the mobile phase.

**Figure 16.** No waste injection mode – load position



**Note** The two 1.5  $\mu\text{L}$  air bubbles isolate the sample from the flush solvent.

## Partial Loop Injection

In the partial loop injection mode, the autosampler withdraws 22  $\mu\text{L}$  of excess sample from the vial in addition to the requested injection volume. The autosampler expels approximately one-half of the excess volume to waste before it meters the center of the sample plug into the front of the sample loop. It expels the second portion of excess sample to waste after the mobile phase stream backflushes the contents of the sample loop onto the column.

Because the autosampler meters sample into the sample loop, the partial loop injection mode is less precise but more accurate than the full loop injection mode. You can inject variable amounts of sample, ranging from a minimum of 0.1  $\mu\text{L}$  to a practical maximum of one-half the volume of your sample loop. The laminar flow of fluid within the stainless steel sample loop causes this maximum volume limitation.

**IMPORTANT** To make precise partial loop injections, limit the maximum injection volume to less than half the nominal sample loop size. Because the accuracy of the nominal volume of the sample loop is  $\pm 20\%$  (which means that the actual volume of the standard 25  $\mu\text{L}$  sample loop is between 20  $\mu\text{L}$  and 30  $\mu\text{L}$ ), for best results, limit the maximum injection volume to 10  $\mu\text{L}$  for the standard sample loop.

## Full Loop Injection

In the full loop injection mode, the autosampler withdraws a sample volume sufficient to overfill the loop (according to the equation given on [page 19](#)). Because the actual injection volume is determined by the size of the loop, not the metering action of the stepper motor, a full loop injection is very reproducible. However, because the full loop injection mode completely fills the sample loop, you cannot inject variable amounts of sample.

Use the full loop injection mode when you want maximum precision and have unlimited sample. However, if you want to change the injection volume, you must replace the attached sample loop with one of a different size. The available sample loop sizes are listed in “Consumables” on [page 124](#).

**Note** You enter the size of the sample loop when you configure the Accela Autosampler.

In the full loop injection mode, the autosampler withdraws a large excess of solution from the sample vial according to the following equation:

$$\text{Amount withdrawn} = 3 \times IV + DV + 7.5 \mu\text{L}$$

Where:

$IV$  = requested injection volume

$DV$  = Volume of the transfer tube + volume of the injection port of the autosampler and the rotor slot (1.6  $\mu\text{L}$ )

This equation is valid until the volume exceeds the maximum capacity of the syringe. If you request a 100  $\mu\text{L}$  full loop injection and your autosampler has a 250  $\mu\text{L}$  syringe, the autosampler withdraws 265  $\mu\text{L}$  of sample solution from the vial, which is the maximum capacity of the syringe. A sample volume equal to the actual volume of the sample loop is injected onto the column. [Table 4](#) lists the maximum capacity for each syringe.

**Table 4.** Maximum volume withdrawn for full loop injections

Nominal syringe size	Maximum volume withdrawn
Concentric 100 $\mu\text{L}$	101 $\mu\text{L}$
Concentric 250 $\mu\text{L}$	265 $\mu\text{L}$
Concentric 500 $\mu\text{L}$	535 $\mu\text{L}$
Standard 2500 $\mu\text{L}$	1544 $\mu\text{L}$ <sup>a</sup>

<sup>a</sup> The data system limits the maximum amount withdrawn to 1544  $\mu\text{L}$ .

## Injection Sequence

The primary sequence of events for the full loop injection mode is as follows:

1. Getting ready for an injection
2. Drawing sample from the vial
3. Loading sample into the loop
4. Injecting sample
5. Post-injection events

The full loop injection mode draws enough sample to overfill both the transfer tube and the sample loop. The no waste injection mode, however, draws only the injection volume requested, and the partial loop injection mode draws only the injection amount requested plus an additional 22  $\mu\text{L}$ .

As a result, unlike the full loop mode, both the partial loop and no waste injection modes require additional solvent to push the sample all the way through the transfer tubing to the injection valve before the sample is loaded into the loop. The syringe draws this extra transport solvent from the wash bottle and uses it to compensate for the volume held by the injection port of the autosampler, the transfer tube, and the rotor slot of the injection valve. Before the sample is loaded into the loop, the syringe uses the transport solvent to push the sample to the injection valve.

The primary sequence of events for both the partial loop injection mode and the no waste injection mode is as follows:

1. [Getting Ready for an Injection](#)
2. [Drawing Transport Solvent \(Partial Loop and No Waste Injections\)](#)
3. [Drawing Sample](#)
4. [Pushing Transport Solvent \(Partial Loop and No Waste Injections\)](#)
5. [Loading Sample into the Sample Loop](#)
6. [Injecting Sample onto the Column](#)
7. [Post-Injection Events](#)

[Table 5](#) outlines the sequential events that occur during an injection.

**Table 5.** Injection sequence

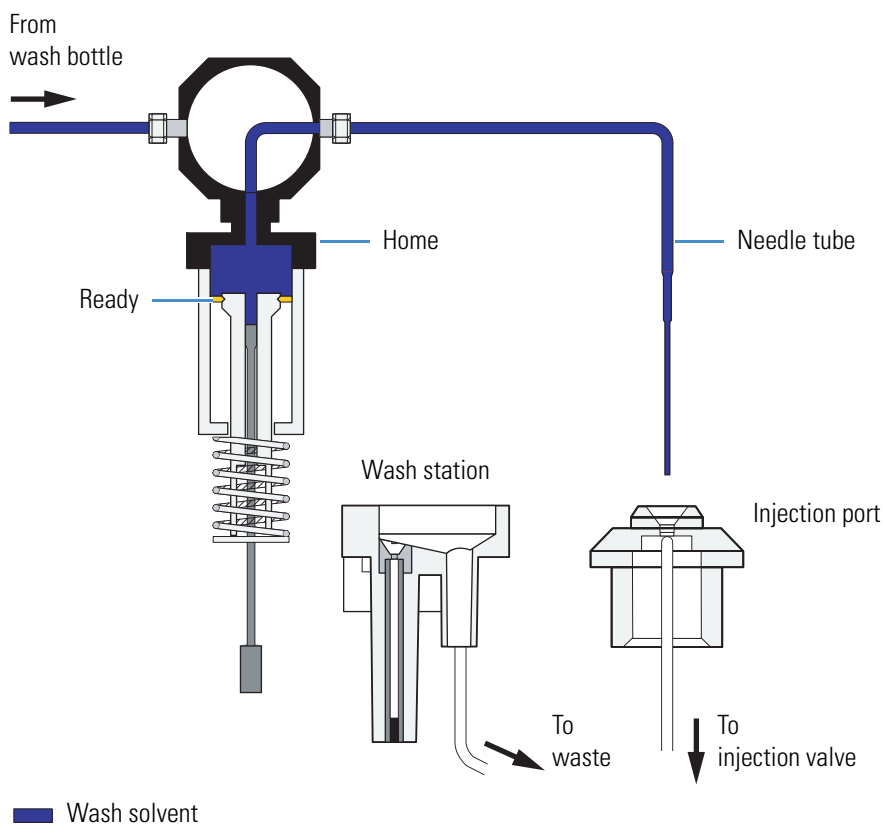
#	Full loop	#	Partial loop	No waste
1	<b>Get ready for injection</b>	1	<b>Get ready for injection</b>	<b>Get ready for injection</b>
			Switch injector to inject position	Switch injector to inject position
	N/A	2	<b>Draw transport solvent</b>	<b>Draw transport solvent</b>
			Switch syringe valve to wash solvent position	Switch syringe valve to wash solvent position
	Switch injector to fill position		Draw wash solvent (transport volume = total dead volume + 7.5 µL)	Draw wash solvent (transport volume = total dead volume)
2	<b>Draw Sample</b>	3	<b>Draw Sample</b>	<b>Draw Sample</b>
	Move XYZ arm to vial		Move XYZ arm to vial	Move XYZ arm to vial
	Switch syringe valve to needle position		Switch syringe valve to needle position	Switch syringe valve to needle position
	Draw 3 µL air bubble		Draw 3 µL air bubble	Draw 1.5 µL air bubble
	Draw sample [(3 × IV) + DV + 7.5 µL]		Draw sample equal to Inject Volume (IV) + 22 µL	Draw sample equal to Inject Volume (IV)
	Draw 3 µL air bubble		Draw 3 µL air bubble	Draw 1.5 µL air bubble
	N/A	4	<b>Push Transport Solvent</b>	<b>Push Transport Solvent</b>
	Move XYZ arm to injection port of autosampler		Move XYZ arm to injection port of autosampler	Move XYZ arm to injection port of autosampler
			Push the transport volume into the transfer tube	Push the transport volume (minus 1 µL) into the transfer tube
3	<b>Load Sample into Loop</b>	5	<b>Load Sample into Loop</b>	<b>Load Sample into Loop</b>
	Overfill the sample loop		Switch the injector to fill position	Switch the injector to fill position
			Meter the sample plug into the loop	Meter the sample plug + air bubbles + 2 µL wash solvent into the loop
4	<b>Switch the injector to inject position</b>	6	<b>Switch the injector to inject position</b>	<b>Switch the injector to inject position</b>
5	<b>Post-Injection Events</b>	7	<b>Post-Injection Events</b>	<b>Post-Injection Events</b>
	Perform optional flush/wash		Perform optional flush/wash	Perform optional flush/wash
	Home syringe		Home syringe	Home syringe
	Prepare for next injection		Prepare for next injection	Prepare for next injection

## Getting Ready for an Injection

Before an injection sequence begins, the autosampler initializes the syringe plunger to the Ready position (see Figure 17).

- If the syringe plunger is in the Home Side of Ready position, the autosampler switches the syringe valve to the solvent bottle position, and then returns the syringe plunger downward to the Ready position at flush speed.
- If the syringe plunger is below the Ready position, the autosampler switches the syringe valve to the needle position, the XYZ arm moves the needle to the wash station, and the syringe plunger moves upward to the Ready position at flush speed.

**Figure 17.** Syringe, syringe valve, and needle position prior to injection (Ready position)



## Drawing Transport Solvent (Partial Loop and No Waste Injections)

To draw transport solvent, the syringe valve switches to the wash bottle position. The amount of solvent that the syringe draws from the wash bottle, referred to as the transport volume, depends on both the injection mode and the configured value for the dead volume.

**IMPORTANT** A transfer tube connects the injection port of the autosampler to port 2 of the injection valve. The transfer tube is labeled with its factory calibrated volume. When you configure the autosampler, you must type the label value in the Dead Volume box of the Accela Configuration dialog box.

In the no waste injection mode, the syringe draws only enough solvent to compensate for the total dead volume of the system according to the following equation:

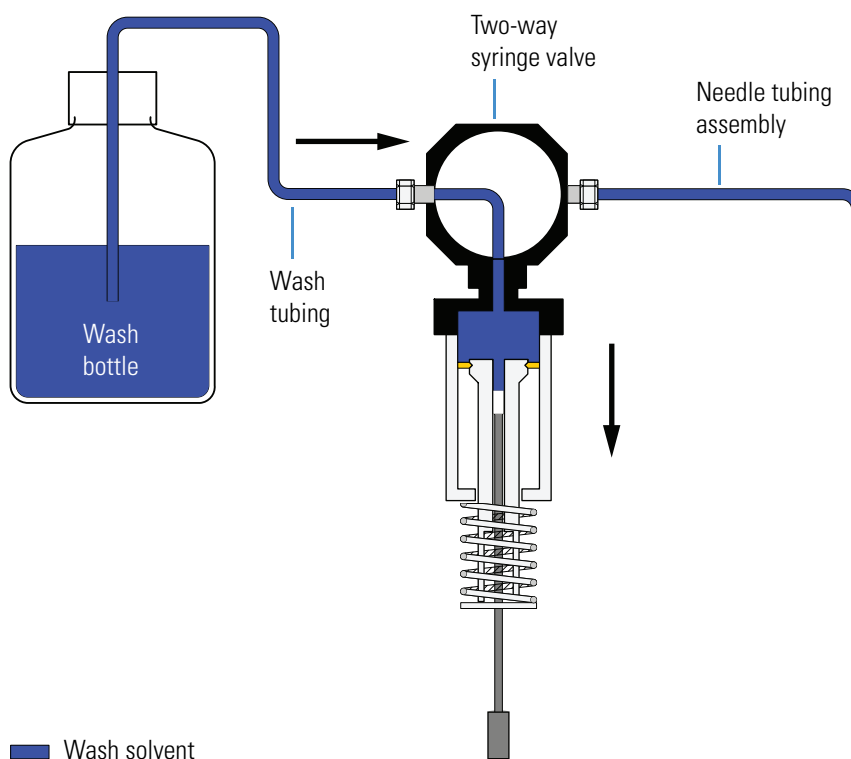
$$\text{Transport solvent volume} = \text{Total dead volume}$$

Where:

Total Dead Volume = Transfer tube volume + volume of the injection port of the autosampler and the rotor slot of the injection valve (1.6  $\mu\text{L}$ )

In the partial loop injection mode, the syringe draws enough solvent from the wash bottle to compensate for the total dead volume of the system plus an additional 7.5  $\mu\text{L}$  of solvent (see Figure 18).

**Figure 18.** Drawing wash solvent from the wash bottle



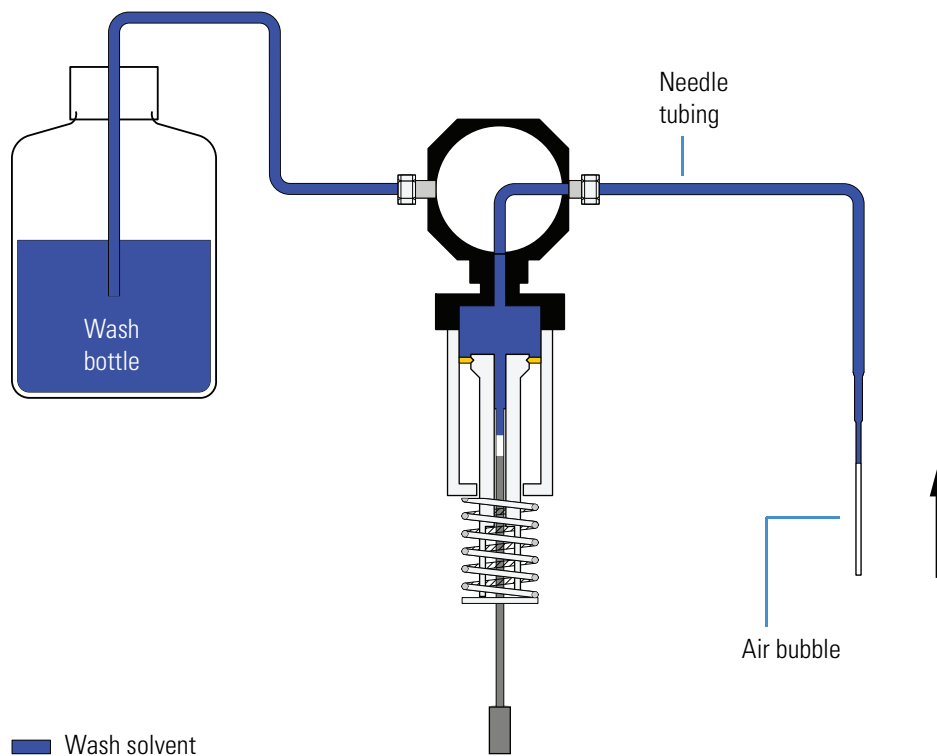
## Drawing Sample

The autosampler draws sample from the sample vial or well as follows:

**Note** For the full loop injection mode, the injection valve rotates to the load position. For both the no waste injection mode and the partial loop injection mode, the injection valve remains in the inject position.

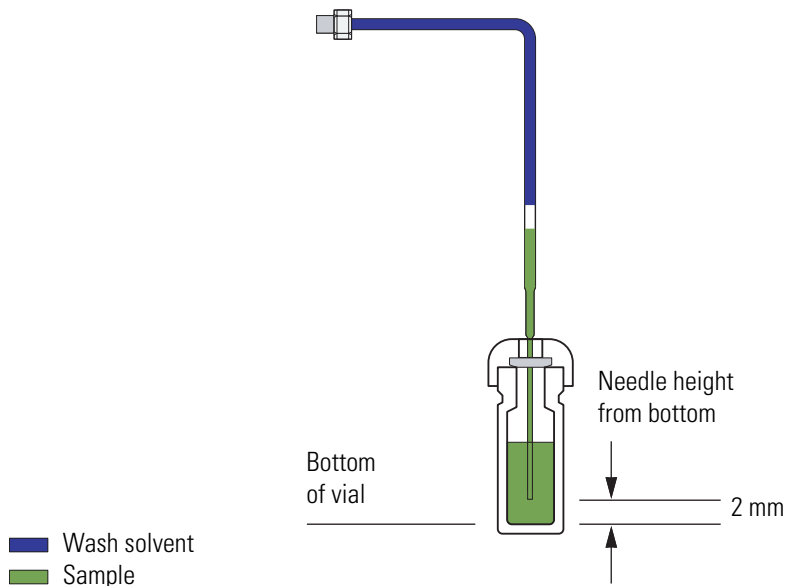
1. The XYZ arm moves to the sample vial.
2. The syringe valve switches to the needle position.
3. The inner syringe plunger descends, drawing an air bubble into the tip of the needle. Depending on the injection mode, the autosampler draws the following volume of air (see Figure 19):
  - For partial loop and full loop injections, the syringe draws 3  $\mu\text{L}$  of air.
  - For no waste injections, the syringe draws 1.5  $\mu\text{L}$  of air.

**Figure 19.** Drawing the first air bubble



4. The XYZ arm lowers the needle tip into the sample vial to the depth requested (see [Figure 20](#)).

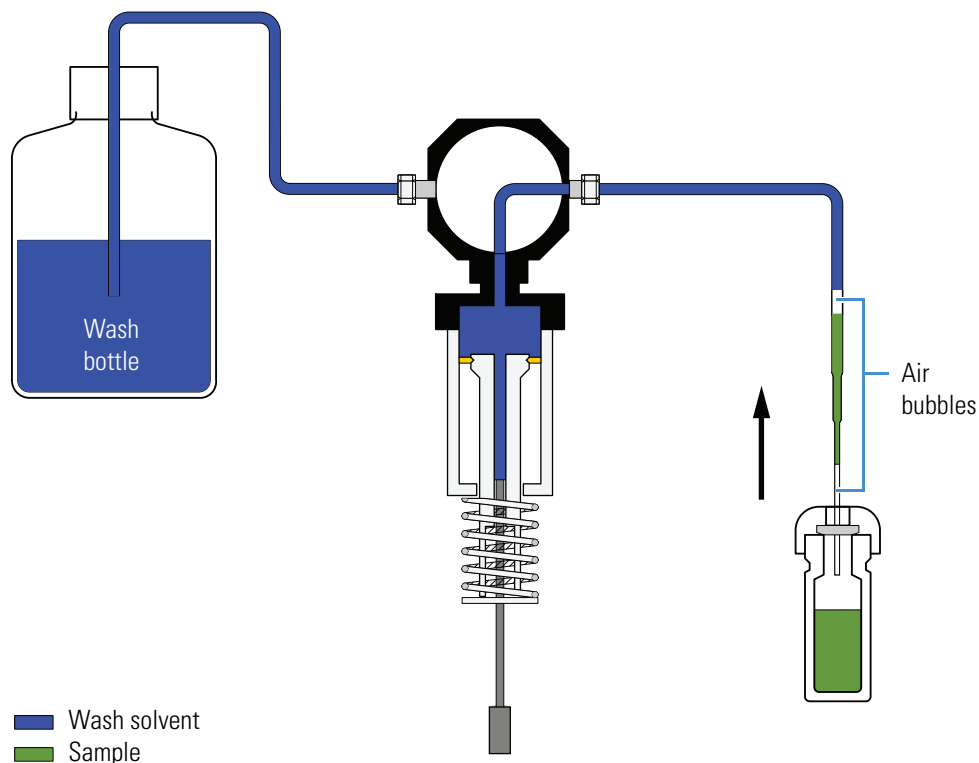
**Figure 20.** Needle withdrawing sample from a standard vial



**Note** The autosampler lowers the needle tip to the position requested in the Needle Height From Bottom box of the Accela Autosampler page of the Instrument Setup dialog box. The allowable range is 0.1 to 18 mm from the bottom of the vial.

5. The inner syringe plunger descends further, drawing sample at syringe sample speed. The volume of sample that the autosampler draws from the vial depends on the requested injection volume and the injection mode as follows:
- For no waste injections, the autosampler draws only the requested injection volume.
  - For partial loop injections, the autosampler draws the requested injection volume plus an additional 22  $\mu\text{L}$ .
6. The XYZ arm raises the needle out of the sample vial (see [Figure 21](#)). The inner syringe plunger descends further, drawing a second air bubble into the needle. The sample plug is now isolated between the two air bubbles.

**Figure 21.** Drawing a second air bubble, which isolates the sample plug



## Pushing Transport Solvent (Partial Loop and No Waste Injections)

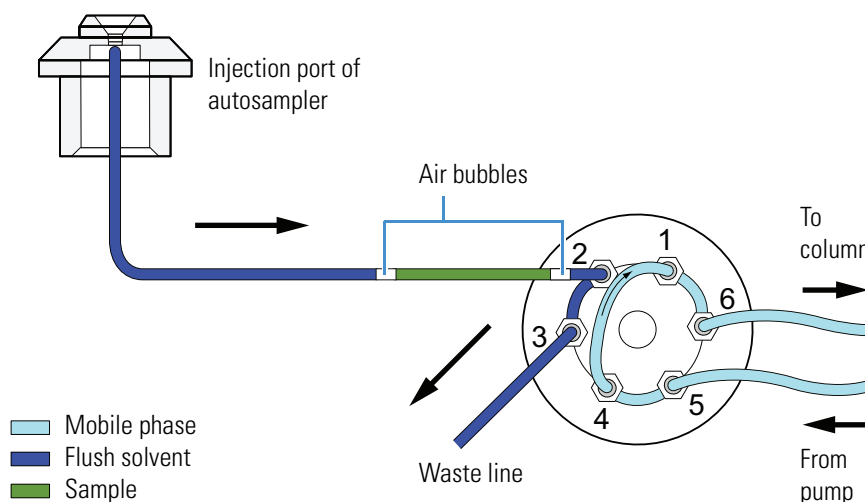
The XYZ arm moves to the home position, and then lowers the needle into the injection port of the autosampler. The inner syringe plunger moves upward, pushing the sample plug followed by the transport solvent into the transfer tube.

The actions that occur during the pushing transport solvent step depend on the injection mode.

## Pushing Transport Solvent Step for No Waste Injections

The needle expels  $1\ \mu\text{L}$  less than the transport volume into the transfer tube. The sample plug falls just short of the entry to the injection port (port 2) of the injection valve (see [Figure 22](#)).

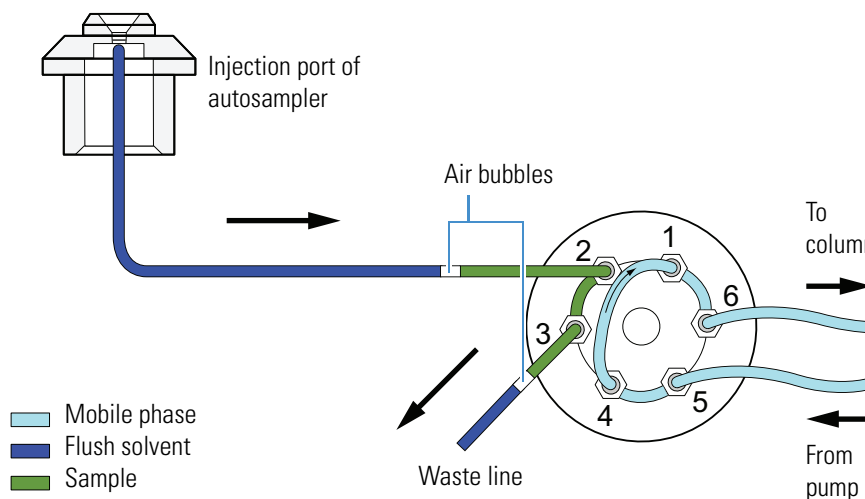
**Figure 22.** No Waste injection—Pushing transport solvent step



## Pushing Transport Solvent Step for Partial Loop Injections

The needle expels the transport volume, which is equal to the dead volume between the injection port of the autosampler and the injection valve plus an excess of  $7.5\ \mu\text{L}$ , into the transfer tube. This pushes  $4.5\ \mu\text{L}$  of the sample plug plus the first  $3\ \mu\text{L}$  bubble through the injection valve and out to waste (see [Figure 23](#)).

**Figure 23.** Partial Loop Injection—Pushing transport solvent step



## Loading Sample into the Sample Loop

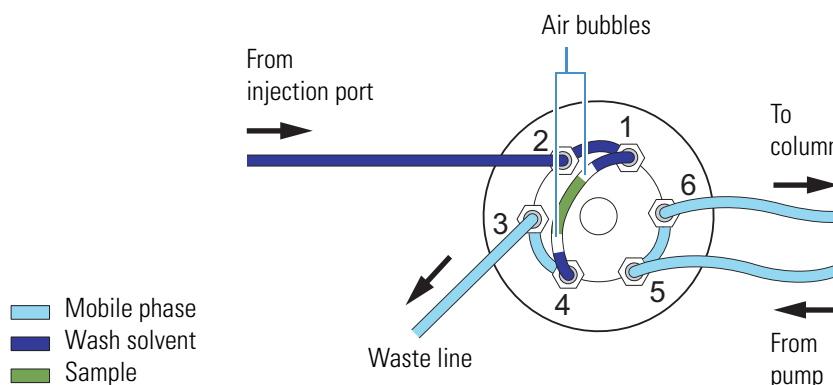
The injection valve switches to the fill position for both the partial loop injection mode and the no waste injection modes. For a full loop injection, the injection valve switches to the fill position at the beginning of the injection sequence. The syringe then pushes the sample into the sample loop. The Accela Autosampler issues a momentary Gradient Start signal.

The actions that occur during the sample loading step depend on the injection mode.

### Sample Loading for No Waste Injections

The syringe meters the requested sample volume plus 5  $\mu\text{L}$  into the sample loop. This pushes the sample plug, the two bracketing air bubbles, and approximately 2  $\mu\text{L}$  of wash solvent into the sample loop (see Figure 24).

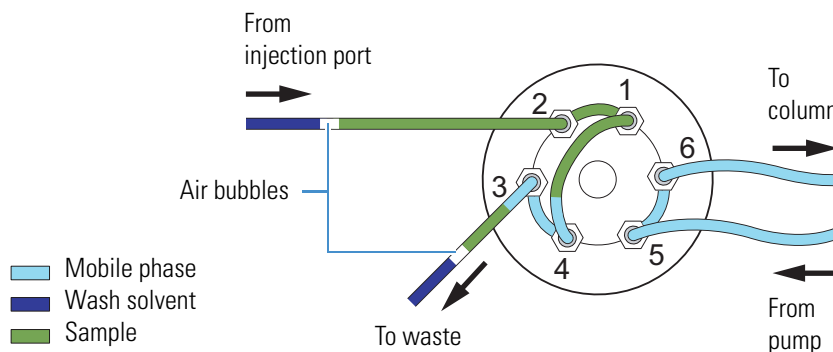
**Figure 24.** No Waste injection—Loading the sample loop



### Sample Loading for Partial Loop Injections

The syringe meters the requested sample volume into the sample loop. This leaves approximately 16  $\mu\text{L}$  of excess sample plus the second 3  $\mu\text{L}$  air bubble in the transfer line (see Figure 25).

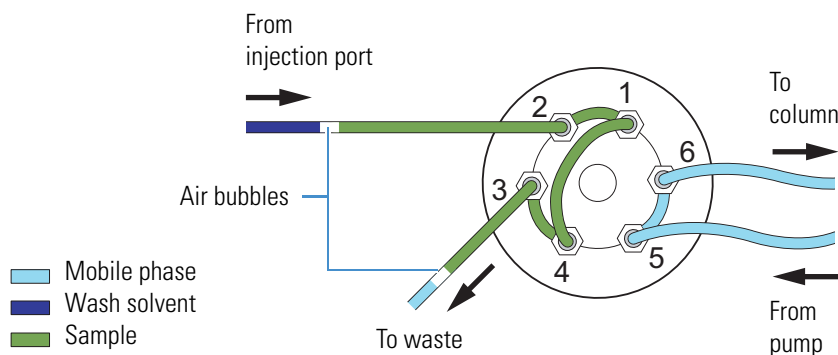
**Figure 25.** Partial Loop injection—Loading the sample loop



## Sample Loading for Full Loop Injections

The needle expels the sample into the sample loop. As the sample loop becomes overfilled, excess sample exits through the waste line (see [Figure 26](#)).

**Figure 26.** Full Loop injection—Loading the sample loop

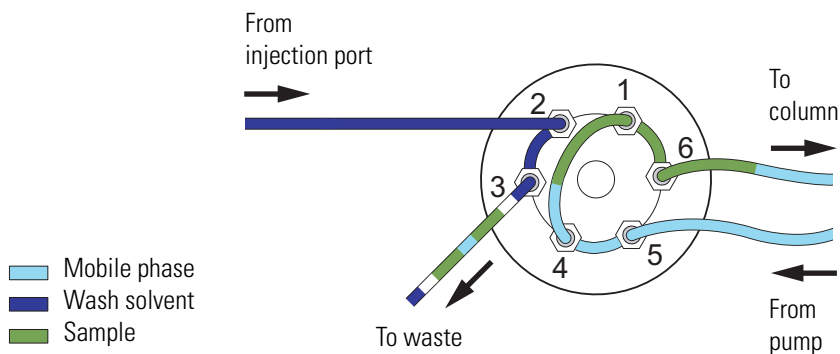


## Injecting Sample onto the Column

The autosampler backflushes the contents of the sample loop onto the column as follows:

1. The injection valve switches to the inject position.
2. Mobile phase enters the sample loop from the back, sweeping the contents of the sample loop onto the column (see [Figure 27](#)).
3. The autosampler issues a momentary Inject Out signal.

**Figure 27.** Partial Loop injection—Injecting sample



## Post-Injection Events

At the end of an injection, the autosampler performs the following operations:

1. The autosampler performs an optional flush, wash, or both as specified in the instrument method.
  - **Flush** (optional): During an internal flush, the autosampler lowers the needle into the injection port, and then dispenses a specified volume of solvent through the needle and transfer line out to waste. You can select the solvent wash bottle or a reservoir vial as the flush solvent source. The internal flush removes excess or residual sample from the injection flow path. It does not flush the sample loop.
  - **Wash** (optional): During an external wash, the autosampler lowers the needle into the wash station, and then dispenses a specified volume of solvent through the needle. As the wash station overfills, the wash solvent flows up over the exterior of the needle, and then out to waste. You can select the solvent wash bottle or a reservoir vial as the wash solvent source.
2. The autosampler moves the syringe plunger to the Ready position, and then switches the syringe valve to point to the wash bottle.
3. The autosampler prepares for the next injection by moving the XYZ arm to the Home position, located above the injection port of the autosampler.

## Autosampler Operation

You have full control of the autosampler from the Xcalibur and ChromQuest data systems and limited control of the autosampler from other Thermo Scientific mass spectrometry applications. The power switch is the only manual control. The data system Help, the *Accela User Guide for LC Devices*, and the *Accela User Guide for the ChromQuest Data System* provide information on how to operate the autosampler.

**Note** You can create instrument methods to control the Accela Autosampler from several Thermo Scientific mass spectrometry applications; however, you can calibrate the Accela Autosampler only from the ChromQuest or Xcalibur data system.

The Help and the manuals (provided as PDF files) include information on how to do the following:

- Calibrate the well bottom position for custom vials or microplates (see [“Calibrating the Accela Autosampler”](#) on page 47).
- Perform direct commands to flush the syringe, move the XYZ arm (see [“XYZ Arm Mechanism”](#) on page 5), inject sample, and so on.
- Create an instrument method for data acquisition.

For information on accessing the manuals, see [“Related Documentation”](#) on page xv.

## Automated Sample Preparation

With the automated sample preparation feature, you can build a pretreatment routine that the autosampler performs before it performs an injection. The pretreatment routine can consist of multiple tasks including transferring liquid between sample vials, transferring liquid from one of the four reservoir vials to a sample vial, mixing, and more.

The autosampler performs each task by drawing liquid into or expelling liquid from the needle tubing. It uses the inner plunger of the concentric syringe for liquid transfers that require a high degree of precision, such as a transfer of liquid between sample vials. It uses the outer plunger of the concentric syringe for liquid transfers that require less precision, such as sample mixing, which is performed using an aspirate and expunge technique.

For a complete list of sample preparation tasks that the autosampler can perform and a set of rules for creating sample preparation routines, refer to the Help provided with the data system.

## Specifications

These are specifications for the Accela Autosampler.

Sample capacity:	<ul style="list-style-type: none"> <li>• 200 vials in five removable trays</li> <li>• 288 samples in three 96-well microplates</li> <li>• 1152 samples in three 384-well microplates</li> </ul>
Standard vial:	<ul style="list-style-type: none"> <li>• 1.8 mL volume</li> </ul>
Injection precision:	<ul style="list-style-type: none"> <li>• <math>\leq 1.0\%</math> RSD at 5 <math>\mu\text{L}</math> and up</li> </ul>
Partial loop injection volume:	<ul style="list-style-type: none"> <li>• 10 <math>\mu\text{L}</math> with standard 25 <math>\mu\text{L}</math> sample loop and 250 <math>\mu\text{L}</math> syringe</li> <li>• Up to 1000 <math>\mu\text{L}</math> injection volume with optional loops and syringes</li> </ul>
Fixed loop (full loop) injection volume:	<ul style="list-style-type: none"> <li>• 25 <math>\mu\text{L}</math> with standard loop and 250 <math>\mu\text{L}</math> syringe</li> <li>• Up to 1000 <math>\mu\text{L}</math> injection volume with optional loops and syringes</li> </ul>
Sample carryover:	<ul style="list-style-type: none"> <li>• <math>\leq 0.1\%</math></li> <li>• 6 mL flush volumes, user-specified for internal and external needle wash cycles</li> </ul>
Minimum sample volume:	<ul style="list-style-type: none"> <li>• 1 <math>\mu\text{L}</math> can be injected from 5 <math>\mu\text{L}</math></li> </ul>
Needle height control:	<ul style="list-style-type: none"> <li>• Programmable in 0.1 mm increments</li> <li>• Active vial bottom search selectable on/off</li> </ul>
Column oven:	<ul style="list-style-type: none"> <li>• Programmable in 1 <math>^{\circ}\text{C}</math> increments from 5 to 95 <math>^{\circ}\text{C}</math></li> </ul>
Tray temperature control:	<ul style="list-style-type: none"> <li>• Programmable in 1 <math>^{\circ}\text{C}</math> increments from 0 to 60 <math>^{\circ}\text{C}</math></li> <li>• Typical vial temperature from 4 to 50 <math>^{\circ}\text{C}</math></li> </ul>
Reagent vials:	<ul style="list-style-type: none"> <li>• Four 16 mL vials can be specified for flush/wash or dilution functions</li> </ul>
Remote inputs:	<ul style="list-style-type: none"> <li>• Pump ready, inject hold</li> </ul>
Remote outputs:	<ul style="list-style-type: none"> <li>• Pump stop, autosampler ready, inject, gradient start, four timed events</li> </ul>
Ambient environment:	<ul style="list-style-type: none"> <li>• 10 to 40 <math>^{\circ}\text{C}</math>, 5 to 95% relative humidity, non-condensing</li> </ul>
Dimensions:	<ul style="list-style-type: none"> <li>• 37 <math>\times</math> 36 <math>\times</math> 50 cm (<math>h \times w \times d</math>)</li> <li>• 14.5 <math>\times</math> 15 <math>\times</math> 20 in. (<math>h \times w \times d</math>)</li> </ul>
Weight:	<ul style="list-style-type: none"> <li>• 30 kg (66 lb)</li> <li>• See “<a href="#">Lifting and Carrying the Autosampler</a>” on <a href="#">page xx</a>.</li> </ul>
Power requirements:	<ul style="list-style-type: none"> <li>• 100/120/220/240 Vac nominal; 50/60 Hz, 550 VA</li> </ul>
Product certification:	<ul style="list-style-type: none"> <li>• CSA, TÜV/GS, FCC (EMI), VDE (EMI)</li> </ul>

# Installation

To install the Accela Autosampler as part of an Accela UHPLC system, use the “[Installation Checklist](#)” on [page 34](#) and follow the procedures in this chapter. Make a copy of the checklist and fill it out when the installation is complete. Include the completed checklist in your maintenance records.

“[Changing the Sample Loop](#)” on [page 48](#) describes how to change the sample loop, a piece of stainless steel tubing with two end fittings connected to the injection valve. For full loop (fixed loop) injections, the sample loop size determines the injection volume.

**Note** Install the Accela Autosampler in the sequence presented in the Installation Checklist.

## Contents

- [Software Compatibility](#)
- [Installation Checklist](#)
- [Unpacking and Inspecting the Instrument](#)
- [Making Initial Instrument Preparations](#)
- [Making the Back Panel Connections](#)
- [Connecting the Solvent Lines](#)
- [Turning On the Autosampler](#)
- [Calibrating the Accela Autosampler](#)
- [Changing the Sample Loop](#)

## Software Compatibility

You have full control of the Accela Autosampler from the ChromQuest chromatography data system and the Xcalibur mass spectrometry application and limited control from several other Thermo Scientific mass spectrometry applications. The following data systems provide compatible firmware and a firmware upgrade utility (see “[Downloading Firmware to the Autosampler](#)” on [page 131](#)):

- For the ChromQuest 4.2 data system, you can find the Accela device drivers on the Accela Device Driver Add-on CD.
- For the ChromQuest 5.0 data system, you can find the Accela device drivers on the ChromQuest CD.
- For the Xcalibur data system, you can find the Accela device drivers on the LC Devices DVD.

## Installation Checklist

The following installation summarizes the steps that you must complete to properly install the Accela Autosampler.

- Unpack and inspect your instrument ([page 35](#)).
- Read the safety notices (front of manual).
- Make the initial instrument preparations ([page 35](#)).
- Make the initial back panel connections ([page 36](#)).
- Power on the autosampler for the first time ([page 46](#)).
- Install the Xcalibur 2.0 (or later) data system or the ChromQuest 4.2 (or later) data system and connect remote communication outputs, as required for external devices that are not controlled by the data system.
- Add the Accela Autosampler to the data system instrument configuration. For instructions on specifying the configuration options for the Accela Autosampler, refer to the *Accela User Guide for LC Devices*, the *Accela User Guide for the ChromQuest Data System*, or the Help provided by the data system.

This Accela Autosampler was installed by:

---

(Name)

(Date)

## Unpacking and Inspecting the Instrument

Carefully remove the autosampler from the shipping container and inspect both the autosampler and packing for any signs of damage. If you find any damage, save the shipping materials and immediately contact the shipping company.

The shipping container contains the Accela Autosampler and an accessory kit. Carefully check to make sure you received all the items listed on the packing list. Ensure that the needle tubing assembly is attached to the XYZ arm and the right side of the syringe valve, a 250  $\mu\text{L}$  dual-concentric syringe is attached to the syringe drive mount, a 25  $\mu\text{L}$  sample loop is attached to the injection valve, and the tray compartment contains five sample trays. Each tray holds 40 standard, 1.8 mL vials arranged in two rows of 20.

If any items are missing, contact your Thermo Fisher Scientific representative immediately.

To connect the autosampler to the other instruments in the Accela stack, you must have the Accela System Kit (see “[Accela System Kit](#)” on [page 127](#)). This kit is provided with orders for instruments sold together with either the Xcalibur or the ChromQuest data system or as a separate option.

## Making Initial Instrument Preparations

Place the autosampler on a benchtop. Allow at least 15 cm (6 in.) of space between the back panel of the autosampler and any wall or obstruction. This provides clearance for the back-panel connectors and cool air flow.



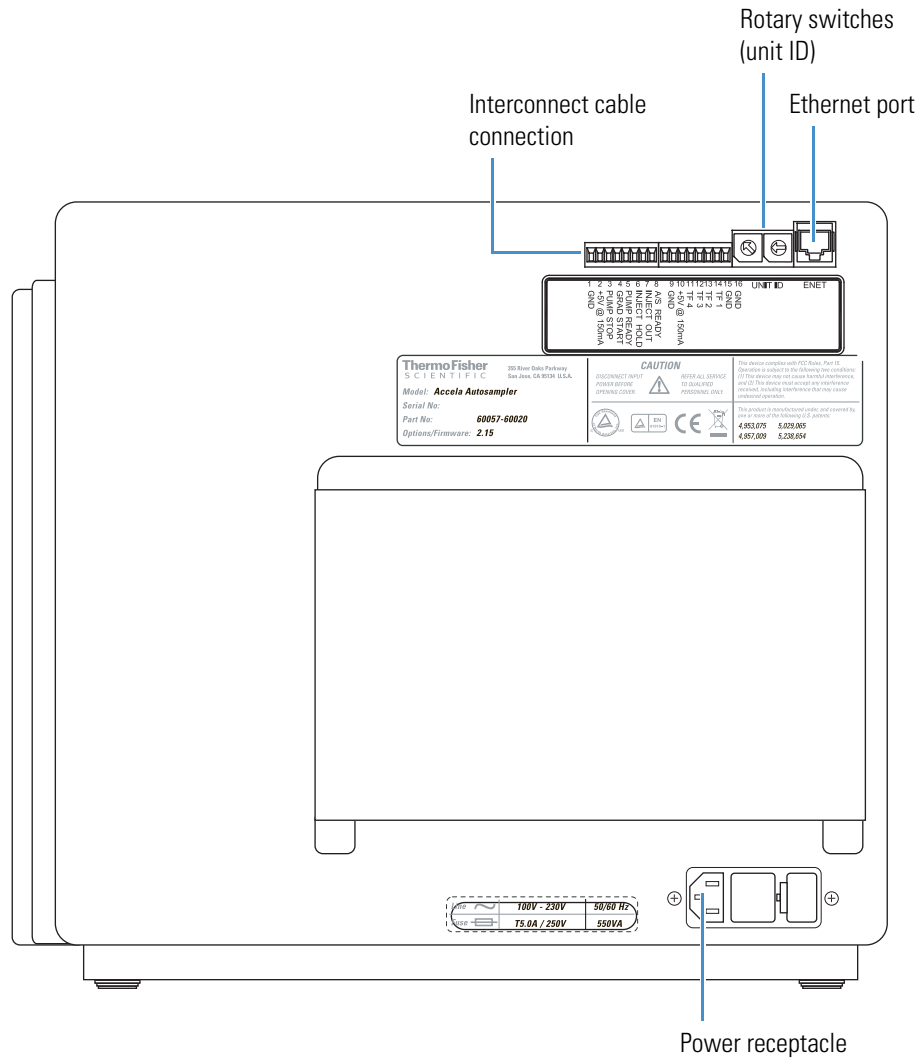
Installing the autosampler requires these tools:

- 5/16 in. open-end wrench
- Narrow flat-head screwdriver

# Making the Back Panel Connections

To operate the Accela Autosampler, connect the power, Ethernet, and system interconnect cable to the back panel (see Figure 28) of the autosampler, and check the unit ID setting.

Figure 28. Back panel of the Accela Autosampler



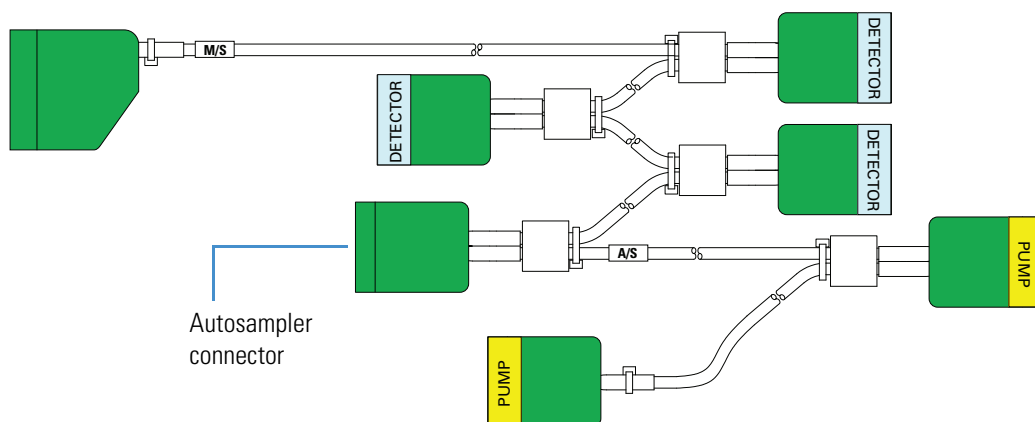
To make the back panel connections, follow these procedures:

- [Connecting the System Interconnect Cable](#)
- [Connecting the Ethernet Cable](#)
- [Checking the Unit ID Settings](#)
- [Connecting the Autosampler to Line Power](#)

## Connecting the System Interconnect Cable

The system interconnect cable that synchronizes the timing of the Accela devices is in the Accela System Kit. The interconnect cable has seven combicon connectors: three have a blue DETECTOR label; two have a yellow PUMP label; one has a small A/S tag on its adjacent cable; and one has a small M/S tag on its adjacent cable (see Figure 29).

**Figure 29.** System interconnect cable with seven combicon connectors



### ❖ To connect the interconnect cable

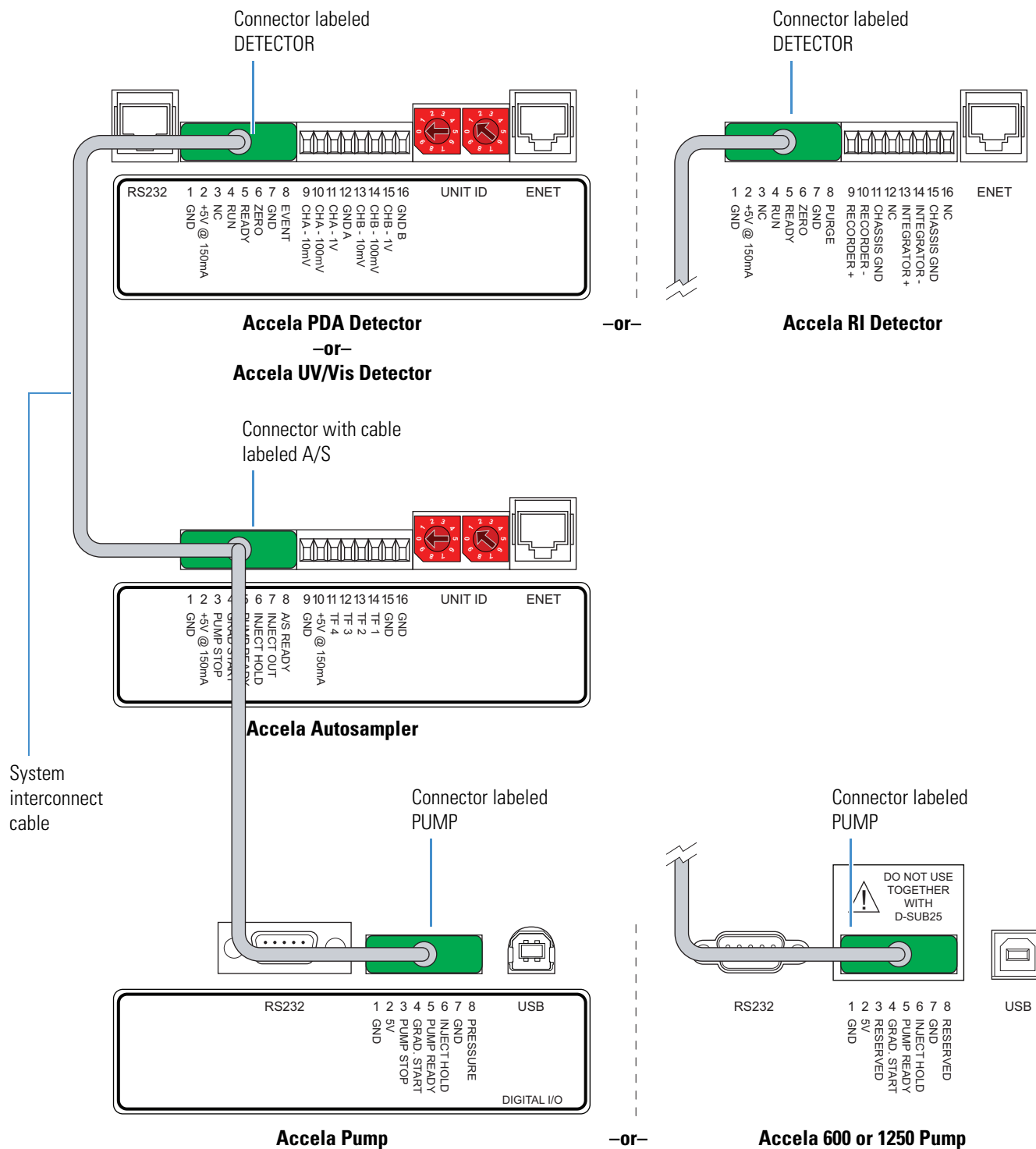
1. Plug the AS connector into the left 8-pin socket on the back panel of the Accela Autosampler (see Figure 30).
2. Attach one of the pump connectors to the Accela pump (Accela Pump, Accela 600 Pump, or Accela 1250 Pump).
3. If your LC system contains an Accela detector, attach one of the detector connectors to it.

Refer to the *Accela Getting Connected Guide* for instructions on how to connect the system interconnect cable to a Thermo Scientific MS detector.

## 2 Installation

### Making the Back Panel Connections

**Figure 30.** System interconnect cable connections



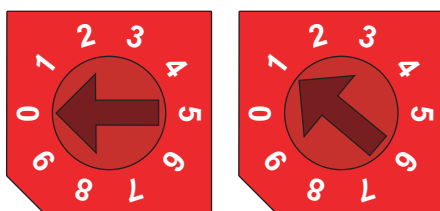
## Connecting the Ethernet Cable

Connect the Ethernet port on the back panel of the Accela Autosampler to the Ethernet switch using the 7 ft length, CAT-5 Ethernet cable with ferrite supplied in the accessory kit.

## Checking the Unit ID Settings

The Accela Autosampler is shipped with the unit ID preset using the two rotary switches located on the back panel (see [Figure 31](#)). The unit ID must correspond with the stack number that you specify in configuring the Accela Autosampler.

**Figure 31.** Rotary switches set to 01



The Communication page (see [Figure 83](#) on [page 120](#)) of the Accela Autosampler Configuration dialog box in the Thermo Foundation Instrument Configuration application contains one box for the unit ID value. The default is 1, and the range is 1 to 99. The Accela AS Configuration dialog box (see [Figure 84](#) on [page 121](#)) in the ChromQuest data system contains two boxes for the unit ID. The default value is 01 and the range is 01 to 99. The value of 0 or 00, respectively, is reserved for special service functions.

## Connecting the Autosampler to Line Power

The Accela Autosampler is shipped with one of these power cords.

Destination	Plug type	Voltage rating	Current rating	P/N
United Kingdom	BS 1363	250 Vac	5 A	6003-0810
Switzerland	SEV 1011	250 Vac	10 A	6003-0620
China and Europe	CEE 7/7	250 Vac	10 A	6003-0330
United States and Canada	NEMA 5-15P	125 Vac	10 A	6003-0160

Local codes in your area might require installing another type of plug and receptacle. The Thermo Fisher Scientific field engineer for your country will provide the appropriate power plugs.

## 2 Installation

### Connecting the Solvent Lines

#### ❖ To connect the autosampler to line power

1. Ensure that the power switch on the front of the unit is in the Off position (released or out position).
2. Check the fuses (see [“Replacing a Fuse”](#) on [page 96](#)).
3. Connect the plug to the power receptacle (see [Figure 28](#) on [page 36](#)) on the back panel of the autosampler.
4. Connect the other end of the power cord to line power.

When you are ready to power on the autosampler, go to [“Turning On the Autosampler”](#) on [page 46](#).

## Connecting the Solvent Lines

Before you can operate the LC system, connect the wash bottle that is contained in the solvent platform to the left side of the syringe valve by using the wash bottle tubing, connect the needle tubing to the right side of the syringe valve, and connect the autosampler to the pump.

To connect the solvent lines, follow these procedures:

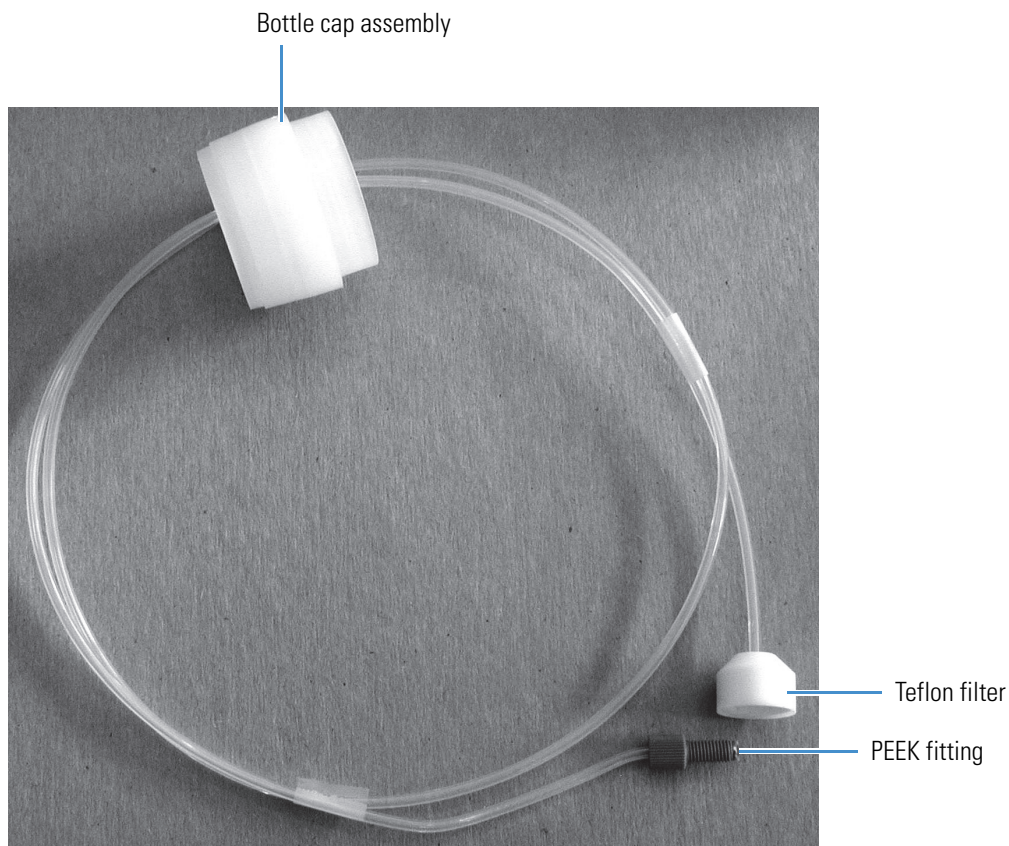
- [Connecting the Wash Bottle](#)
- [Connecting the Needle Tubing](#)
- [Connecting the Autosampler to the LC Pump](#)

**IMPORTANT** If the wash bottle tubing runs dry during a sequence of injections, the autosampler makes “blank” injections.

## Connecting the Wash Bottle

The Wash Bottle Kit supplied in the Accela System Kit contains a 1 liter bottle and a tubing assembly (see [Figure 32](#)).

**Figure 32.** Wash bottle tubing assembly



### ❖ To connect the wash bottle

1. Fill the wash bottle with an appropriate solvent, and then place it in the solvent platform on the top of the system stack.

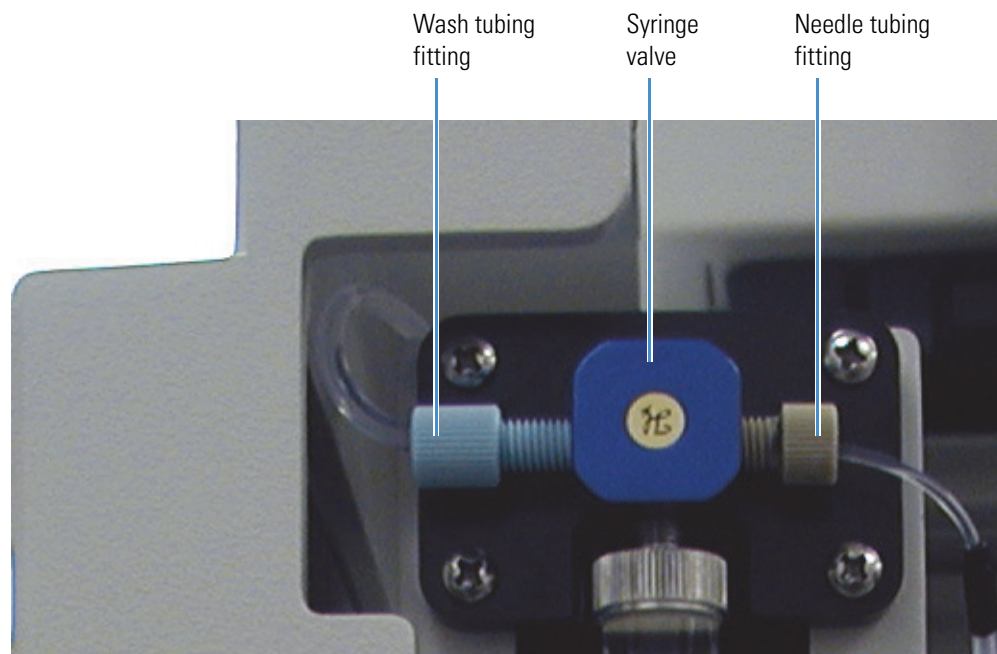
**Note** The solvent platform holds the 1 L wash bottle and four 1 L solvent reservoir bottles. In case of breakage, the solvent platform can hold up to 7 L and acts as a secondary container for the liquid in the solvent bottles.

2. Insert the Teflon filter into the bottom of the bottle and screw on the cap.
3. Connect the PEEK fitting to the left side of the syringe valve (see [Figure 33](#)).

## 2 Installation

### Connecting the Solvent Lines

**Figure 33.** Wash tubing and needle tubing connections



## Connecting the Needle Tubing

The Accela Autosampler is shipped with the needle tubing assembly connected and routed through the appropriate brackets. The internally threaded fitting of the needle tubing assembly is connected to the needle assembly and the externally threaded fitting is connected to the syringe valve. The needle tubing is routed through a bracket on the XYZ arm, a bracket on the left wall of the tray compartment, and a bracket on the tray compartment door. In addition, the two-pronged needle tubing guide is connected to the *x*-axis positioning frame, and the PVC cap (red or black) is pushed below the metal runner for the *x*-axis positioning frame.

Before you operate the autosampler, make sure that the needle tubing is routed through the appropriate brackets.



**CAUTION** The needle tubing is easily damaged. Before you operate the autosampler, make sure that the needle tubing is routed through the support brackets, that the needle tubing guide is connected to the *x*-axis positioning frame, and that the PVC cap is pushed below the metal runner for the *x*-axis positioning frame.

## Connecting the Autosampler to the LC Pump

After you set up the Accela LC stack on the laboratory benchtop, connect the pump outlet to the autosampler inlet (heat exchanger inlet).



**CAUTION** To prevent personal injury, before connecting the pump to the autosampler, make sure that the column oven compartment is at room temperature.

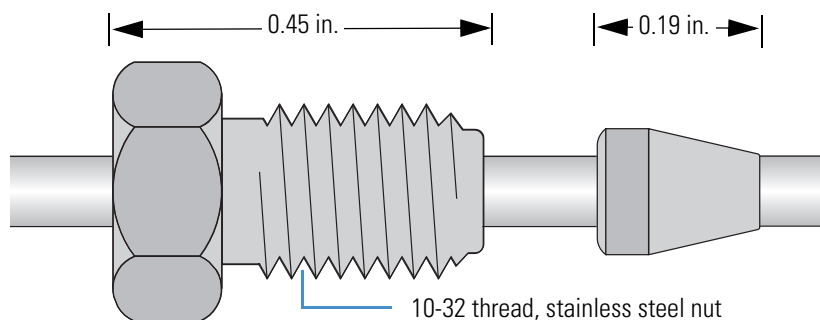


**CAUTION** To prevent personal injury caused by skin contact with hazardous solvents, ensure that the pump is off before you connect it to the autosampler.

### ❖ To connect the Accela pump outlet to the heat exchanger inlet

1. Connect a length of high-pressure tubing to the Accela pump outlet as follows:
  - a. Using a stainless steel, two-piece fitting with a 10-32 thread, 0.45 in. length nut and a 0.19 in. length ferrule (see Figure 34), connect a length of stainless steel, 0.005 in. ID × 1/16 in. OD tubing to the pump outlet.

**Figure 34.** Stainless steel two-piece fitting supplied in the current Accela System Kit



**Tip** To prevent leaks, use an appropriate fitting to connect tubing to the pump outlet. Using a fitting that is too short for the port will cause leaks.

You can find these fittings in the Accela System Kit. You can also order replacement ferrules from VIC Valco™ Instruments Company and replacement nuts from IDEX Corporation.

Item	Third-party part number	Thermo Fisher Scientific part number
Ferrule, stainless steel, 0.19 in. length, for 1/16 in. OD tubing	VICI Valco ZF-1	00101-18122
Nut, 10-32 thread, 0.45 in. length, for 1/16 in. OD tubing	IDEX U-320	2522-1880

The tubing length depends on the pump model:

- For the Accela Pump, connect a 20 cm (8 in.) length of precut tubing to the outlet of the dynamic mixer.
- For the Accela 600 Pump or the Accela 1250 Pump, connect a 26 cm (10 in.) length of precut tubing to the outlet of the placeholder module or the optional dynamic mixer.

**Tip** To identify the tubing ID, the precut tubing has a color-coded band:

- Red = 0.005 in.
- Black = 0.007 in.
- Blue = 0.010 in.
- Yellow = 0.020 in.

- Using a 0.25 in. open-end wrench, tighten the nut.
- Route the tubing through the access slot in the autosampler drip tray.

**Note** The following instructions describe the plumbing connections to the current heat exchanger. For information about the original version of the heat exchanger, see “Legacy Versions of the Accela Autosampler” on page 139.

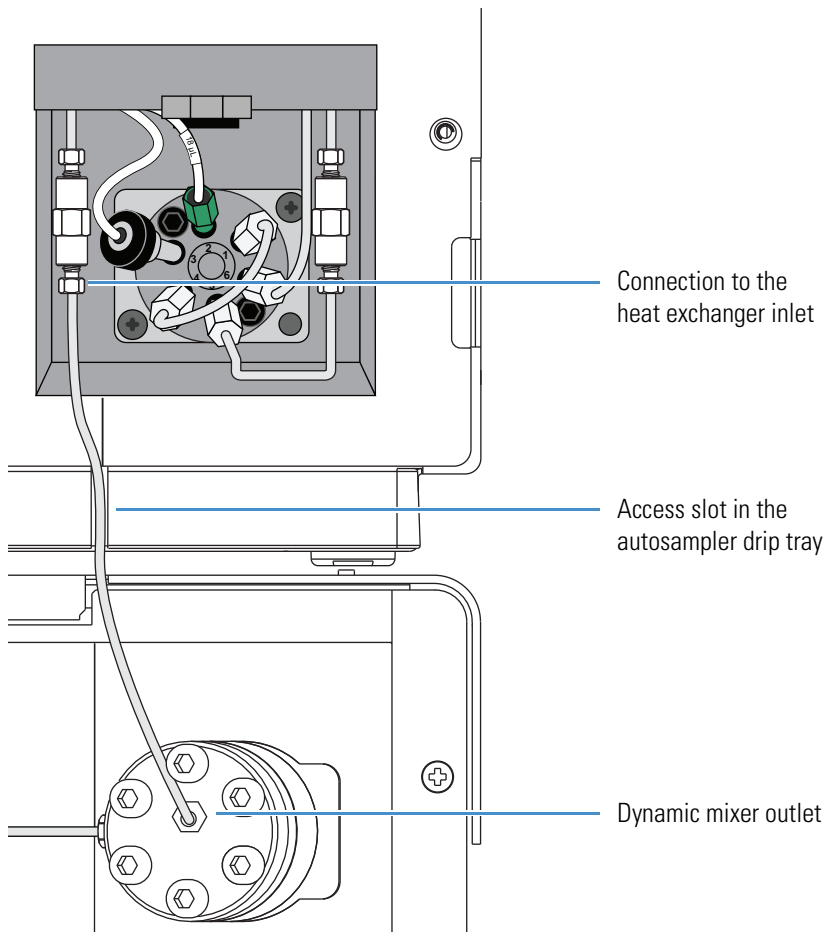
- Connect the free end of the tubing to the heat exchanger inlet as follows:
  - Using a stainless steel high-pressure fitting, connect the free end of the tubing to a stainless steel union. Using a 0.25 in. open-end wrench, tighten the nut.
  - Using a stainless steel high-pressure fitting, connect the free end of the union to the heat exchanger inlet. Using a 0.25 in. open-end wrench, tighten the nut.

You can order replacement fittings to connect the heat exchanger inlet and outlet from IDEX Health and Science.

Item	IDEX part number (subject to change)
Nut, stainless steel, 10-32 thread, 0.40 in. length, external threads, for 1/16 in. OD tubing	U-400
Ferrule, 0.16 in. length, for 1/16 in. OD tubing	U-401
Union, 10-32 threads, 0.010 in. thru-hole	U-435 (comes with U-400 and U-401)

Figure 35 shows the high-pressure connection between the autosampler and an Accela pump with a dynamic mixer.

**Figure 35.** Solvent line connection between the Accela pump and the autosampler



## Turning On the Autosampler

After installing solvent lines and connecting the autosampler to line power, you can turn on the autosampler.

### ❖ To turn on the power to the autosampler

1. Ensure that the power switch at the front of the unit is in the Off position (released or out position).
2. Attach the power cord to the power entry module on the back panel of the autosampler and connect it to the power source.
3. Turn the power on by pushing the power button in to engage it.
4. Make sure that the power indicator briefly lights amber and then turns solid green. If it does not light at all, see [Chapter 6, “Routine Troubleshooting.”](#) If it stays amber or flashes amber or green, turn the power off for several seconds, and then turn it back on again. Call your Thermo Fisher Scientific service representative if you require assistance.

These events occur during the autosampler startup sequence:

1. The Power LED turns solid green.
2. If the autosampler is communicating with the data system computer, the Com LED turns from amber to green.
3. The Run LED and Temperature LED turn solid green.
4. The autosampler initializes the syringe, injection valve, and XYZ arm positions as follows:
  - a. Switches the two-way syringe valve to the flush bottle position.
  - b. Switches the injection valve to the inject position.
  - c. Moves the syringe to the home (empty) position.
  - d. Moves the syringe to the ready position.
  - e. Switches the two-way syringe valve to the needle position.
5. If the autosampler is communicating with the data system computer, the Com LED turns from amber to solid green.
6. Every time you close and reopen the data system, the autosampler initializes its hardware components (see [step 4](#)).

## Calibrating the Accela Autosampler

The Accela Autosampler is factory calibrated. The data system provides calibration options for the following:

- Column oven temperature
- Tray compartment temperature
- XYZ arm position
- Depth of custom vials or microplate wells

Only a Thermo Fisher Scientific service representative can perform the first three calibration options.

Before you use any of the three custom tray options, perform the calibration that determines the z-axis distance that the needle must travel to reach the bottom of your custom vial or well plate.

### ❖ To access the well bottom distance calibration option from the Xcalibur data system



1. From the Roadmap view, click the **Instrument Setup** icon.

The Instrument Setup window appears.

2. Click the **Accela AS** icon in the viewbar.

The Instrument Setup view for the Accela Autosampler appears.

3. From the Accela AS menu, choose **Calibration**.

The Calibration dialog box appears.

4. Select the **Well Bottom Distance** option.

### ❖ To access the well bottom distance calibration option from the ChromQuest data system

1. From the Instrument window, choose **Control > Instrument Status**.

2. Click the **Accela AS** tab.

3. Click **Diagnostics**.

4. Click the **Calibration** tab.

5. Select the **Bottom Distance Calibration** option.

For instructions on how to perform this calibration, refer to the data system Help.



## Changing the Sample Loop

Several sample loop sizes are available for the Accela Autosampler's Valco injection valve (see [Table 6](#)).

**Note** To order sample loops for the original Rheodyne™ injection valve, see “Consumables” on [page 124](#).

**Table 6.** Sample loops for the Valco injection valve

Description	Thermo Fisher Scientific part number	VICI Valco part number
5 µL	00109-99-00007	CSL5
10 µL	00109-99-00008	CSL10
20 µL	00109-99-00009	CSL20
25 µL	00109-99-00010	CSL25
50 µL	00109-99-00011	CSL50
100 µL	00109-99-00012	CSL100
500 µL	00109-99-00013	CSL500
1000 µL	00109-99-00014	CSL1K

### ❖ To change the sample loop

1. Make sure that the autosampler is in Idle mode.
2. Using an open-end wrench, loosen the fittings at ports 1 and 4, and gently pull out the two ends of the sample loop. If you want to reuse the sample loop, label the end fittings with the port number (1 or 4) that the swaged fitting was connected to.
3. Insert the ends of the new sample loop in the same orientation as the old one.
4. Firmly press one end of the sample loop into port 1 of the injection valve as you hand-tighten the nut.
5. Firmly press the other end of the sample loop into port 4 of the injection valve as you hand-tighten the nut.
6. Using a 1/4 in. open-end wrench, gently tighten the fittings by an additional 3/4 turn.

**Tip** To connect tubing with a two-piece stainless steel fitting to a receiving port, press the tubing against the bottom of the port as you hand-tighten the fitting. Then tighten the fitting by an additional 3/4 turn with a wrench. Once you use the wrench to tighten the fitting, the ferrule portion of the two-piece fitting is permanently connected to the tubing.

To connect tubing with a pre-swaged fitting to a receiving port, press the tubing against the bottom of the port as you hand-tighten the fitting. Then tighten the fitting by an additional 1/4 to 1/2 turn with a wrench.

## Sample Loading

Before you load your samples into the autosampler, make sure that your samples are completely soluble in the mobile phase and that you have filtered your samples and solvents through a 0.5  $\mu\text{m}$  filter. These techniques minimize sample precipitation in the lines and remove particulate matter that could obstruct the flow through the autosampler injector or the column. In addition, make sure that the vial caps are securely fastened to the vials.

After you finish preparing your samples, you are ready to load them into the Accela Autosampler. The Accela AS Accessory Kit (see “[Accela AS Accessory Kit](#)” on [page 126](#)) contains trays that hold standard vials, inserts that hold 100  $\mu\text{L}$  vials, and carrier plates that hold 96- and 384-microwell plates.

### Contents

- [Standard Tray Type](#)
- [Carrier Trays for Microplates](#)
- [Important Precautions for Sample Loading](#)
- [Recommended Vials, Microplates, and Microplate Covers](#)

## Standard Tray Type

The Accela Autosampler ships with five standard trays (A, B, C, D, and E) arranged in the autosampler from left to right. Each tray holds 40 standard, 1.8 mL vials arranged in two rows of 20. The accessory kit also contains a supply of standard, 1.8 mL vials, silicone and Teflon septa, and screw-top vial caps. You can order additional vials from Thermo Fisher Scientific.

The part numbers of the replaceable components in the accessory kit are listed in “[Accela AS Accessory Kit](#)” on [page 126](#).

**IMPORTANT** If you are using screw cap vials, the caps must be firmly tightened. If the caps are not firmly tightened, the needle might push the septum into the bottom of the vial.

To install the standard tray type, follow these procedures:

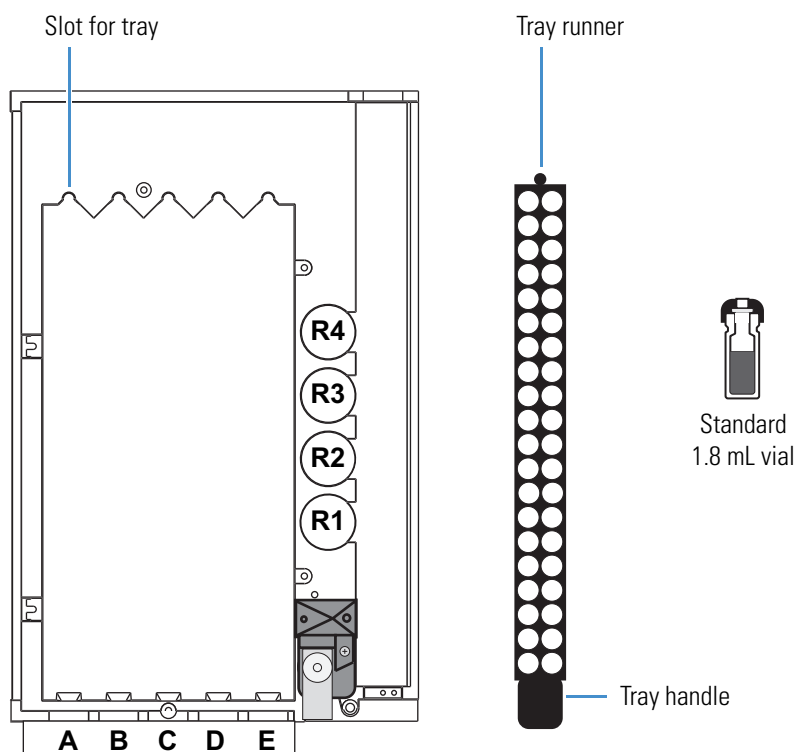
- [Installing the Standard Tray Type](#)
- [Moving the XYZ Arm to the Back of the Tray Compartment](#)

## Installing the Standard Tray Type

### ❖ To install the sample trays into the tray compartment of the autosampler

1. Open the left door of the autosampler.
  - If you selected the Verify Door Is Closed check box when you configured the autosampler, the XYZ arm moves to the back of the tray compartment.
  - If the XYZ arm does not move to the back of the tray compartment, perform the appropriate direct command from the data system.
2. Hold the tray handle, tilting the back end of the tray down.
3. Insert the tray runner into the slot at the back of the tray compartment (see [Figure 36](#)).
4. Lower the front of the tray into place and press down firmly to seat the tray.

**Figure 36.** Tray compartment and standard tray



**IMPORTANT** Be sure that each tray is properly seated. If a tray is not completely seated, the autosampler will not operate correctly.

**IMPORTANT** To trigger the vial sensor, you must position custom vials in the tray so that the top of the vial reaches the minimum height of 1.55 in. Custom vials that fall below this minimum height do not trigger the vial sensor. When an acquisition sequence incurs a vial that is below the minimum height, the sequence halts and the following message appears: Vial Not Found.

**Note** When you open the autosampler door, the XYZ arm automatically moves to the back of the autosampler, allowing you to add samples to the tray during a run. After the door is closed, the arm returns to its position and resumes the operation that was in progress before the door was opened. You can enable this door interlock feature in the Configuration menu for the autosampler.

The accessory kit also contains a tray adapter for 100  $\mu$ L vials and a tray adapter plate for microcentrifuge tubes.

❖ **To use the tray adapter**

Insert the tray adapter into the standard tray, and then secure it with the 1/4 in. Phillips head screw from the accessory kit.

## Moving the XYZ Arm to the Back of the Tray Compartment

If you did not select the Verify Door Is Closed check box when you configured the autosampler, the XYZ arm does not move to the back of the tray compartment when you open the tray compartment door. From the data system, use a direct command to move the XYZ arm.

❖ **To move the XYZ arm to the back of the tray compartment**

- For the Xcalibur data system, open the Direct Control dialog box for the autosampler (see [“Using the Xcalibur Direct Control Commands”](#) on page 141). Select **Position Arm to Access Tray**, and then click **Apply**.
- For the ChromQuest data system, open the Direct Controls page for the autosampler (see [“Using the ChromQuest Direct Commands”](#) on page 143). Select **Position Arm to Access Tray**, and then click **Submit**.

## Carrier Trays for Microplates

In addition to the standard tray option, the accessory kit contains a short microwell plate carrier and a tall, solid microwell plate carrier. These carrier trays hold up to three microplates. To use PCR plates, you can order a cooling adapter from Thermo Fisher Scientific.

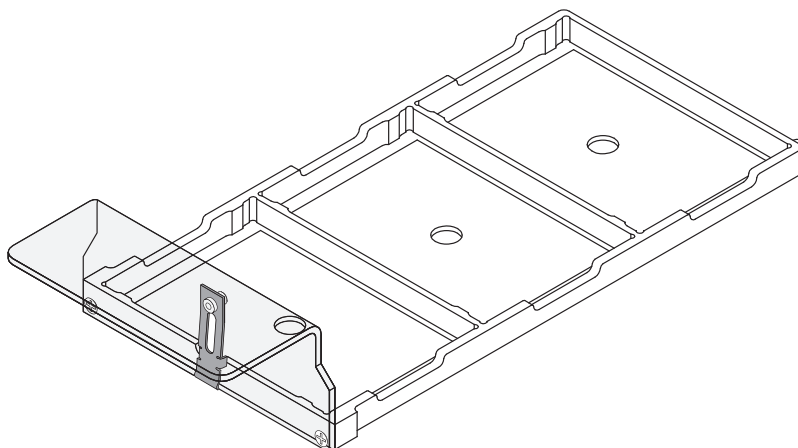
Use the carrier trays as follows:

- For either 1 mL or 2 mL deep well plates, use the short microwell carrier.
- For PCR plates, use the short microwell carrier in combination with the cooling adapter.
- For standard depth 96- or 384-well plates, use the tall, solid microwell carrier.

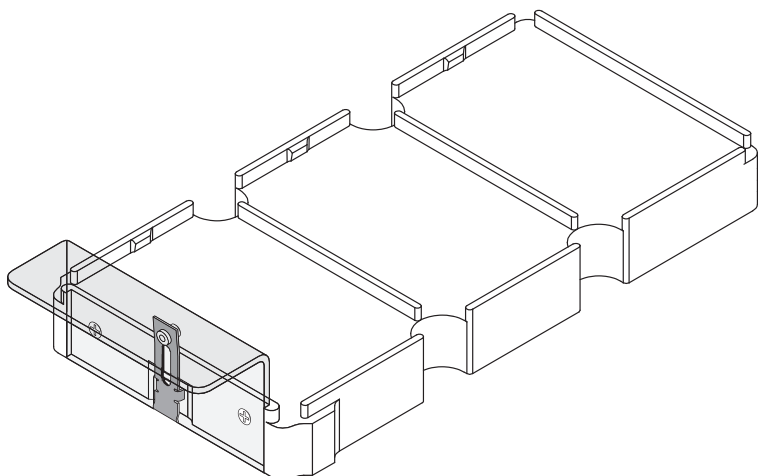
**Note** If your samples require low temperature cooling, use the cooling adapter and the PCR plates instead of the standard 96-well microplates.

Figure 37 and Figure 38 show the short microwell plate carrier and the tall, solid microwell plate carrier, respectively.

**Figure 37.** Short microwell plate carrier



**Figure 38.** Tall, solid microwell plate carrier

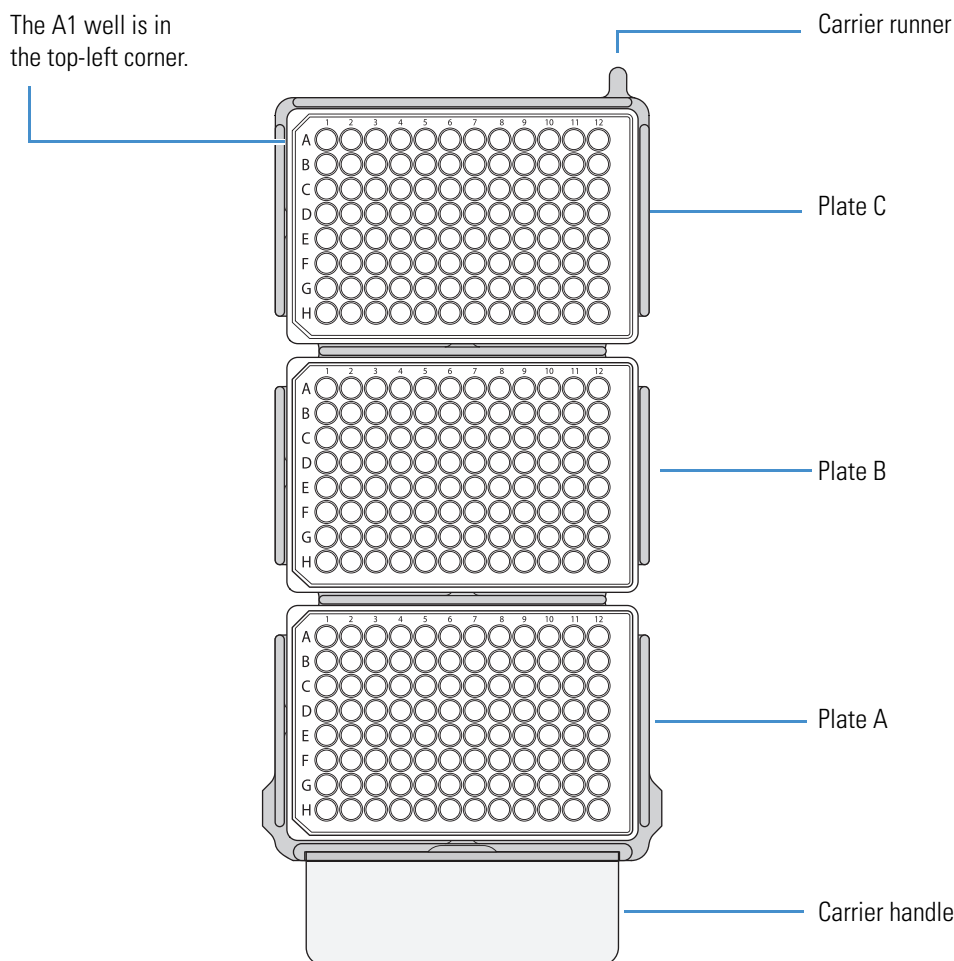


❖ **To install the microplates onto the carrier tray**

1. If this is an option in your data system, determine the microplate orientation.  
With the Xcalibur and ChromQuest data systems, you can select the A1 top-left or A1 bottom-right orientation.
2. Hold the plates in the appropriate orientation as you snap them into the carrier slots.

Figure 39 shows a carrier with three 96-well plates in the A1 top-left orientation.

**Figure 39.** Carrier with three 96-well plates in the A1 top-left orientation



❖ **To load the carrier tray into the autosampler tray compartment**

1. Holding the carrier handle, insert the carrier runner into the slot in the back of the tray compartment tub.

**Tip** Use two hands to hold the tall, solid microwell carrier, as it weighs approximately 2.6 kg (5.8 lb).

2. Lower the front of the carrier tray into place.

## Important Precautions for Sample Loading

Because the needle mechanism moves to the vial or well during an injection sequence, punctures the vial septum or microwell plate cover, and then draws sample from a specified depth, follow these precautions when you load samples into the autosampler tray compartment:

- Check the height of custom trays before you place them in the tray compartment.

Objects taller than 4.5 cm (1.8 in.) can stall the autosampler arm. You must check the height of custom trays before you place them in the tray compartment.

- Use only recommended vials, vial caps, microplates, and microplate covers.

Thermo Fisher Scientific has tested the vials, vial caps, microplates, and microplate covers listed in the next section, [“Recommended Vials, Microplates, and Microplate Covers,”](#) for use with the Accela Autosampler. Because the tip of the needle is blunt, the durometer (material hardness) of the vial cap septum is extremely important, as the needle might not properly pierce septa that are not recommended.

- Ensure that you screw on the vial caps tightly.

If the vial cap is loose, the needle can dislodge the septum during an injection. The needle can also dislodge the septum if it pierces the edge of the septum, rather than its center. If you suspect the needle is out of alignment, call your local Thermo Fisher Scientific service engineer to calibrate its alignment.

- Calibrate the depth of custom vials or microwell plates.

If you are using one of the three custom tray configurations, you must perform a calibration that determines the distance between the tip of the needle and the bottom of your vials or wells. Performing this calibration ensures that the needle tip descends to the height specified in your instrument method as it withdraws sample from the vial or well. Perform this calibration whenever you change the custom tray type configuration or use a different type of custom vial or microplate.

For instructions on how to perform bottom distance calibration, refer to the data system Help for the autosampler or the Accela user guide or getting started guide for your data system.

## Recommended Vials, Microplates, and Microplate Covers

Thermo Fisher Scientific has tested and recommends the following vials, microplates, and microplate covers for use in your Accela Autosampler.

### Recommended Vials

Table 7 lists the recommended sample vials.

**Table 7.** Approved vials

Description	Qty/pkg	Part number
1.8 mL vial with septa and screw cap	100	A4954-010
1.8 mL amber vial with septa and screw cap	100	A4965-010
Shell vial with cap	100	A4948-010
Shell vial with 100 $\mu$ L insert and cap	100	60053-62008
1.8 mL vial with cross-slit septa and screw cap	100	A5400-010

### Recommended Microplates

The microplate carriers hold three low-density 96-well or three high-density 384-well microplates.

#### Low-Density Microplates

All 96-well microplates that meet the dimensions of the Society for Biomolecular Screening and that have a maximum height of 0.80 cm (0.32 in.) are suitable. Polypropylene is the preferred material when working with organic samples.

Table 8 lists the 96-well microplates that Thermo Fisher Scientific approves for use with the Accela Autosampler. The supplier is SUN-SRI, a subsidiary of Thermo Fisher Scientific Inc.

**Table 8.** Recommended 96-well microplates

Description	Qty/pkg	Part number
96-well, U-bottom, Polypropylene, working well volume 250 $\mu$ L	10	500 833
	100	500 811
96-well, V-bottom, Polypropylene, working well volume 190 $\mu$ L	10	500 835
	100	500 813

### 3 Sample Loading

Recommended Vials, Microplates, and Microplate Covers

#### High-Density Microplates

All 384-well microplates that meet the dimensions of the Society for Biomolecular Screening and that have a maximum height of 0.32 in. are suitable. Polypropylene is the preferred material when working with organic samples.

Table 9 lists the 384-well microplates that Thermo Fisher Scientific approves for use with the Accela Autosampler.

**Table 9.** Recommended 384-well microplates

Description	Qty/pkg	Part number
384-well, U-bottom, Polypropylene, working well volume 90 µL	10	500 841
	100	500 819

#### Recommended Microplate Covers

Table 10 lists the covers for 96-well microplates that Thermo Fisher Scientific approves for use with the Accela Autosampler.

**Table 10.** Recommended 96-well microplate covers

Description	Qty/pkg	Source	Supplier catalog number
Micromat II/PS Round Pink Material: Teflon-coated silicone rubber	10/pkg	Thermo Fisher Scientific	400 079
Micromat CLR 96-well PS 7 mm Material: clear silicone rubber	10/pkg	Thermo Fisher Scientific	300 005
Clear heat-seal film	100/pkg	Thermo Fisher Scientific Matrix Technologies Inc.™	AB-0685
VIEWseal™ dry film adhesive-backed tape	100/pkg	Greiner Bio-One	676070

Table 11 lists the 384-well microplate covers that Thermo Fisher Scientific approves for use with the Accela Autosampler.

**Table 11.** Recommended 384-well microplate covers

Description	Qty/pkg	Source	Supplier catalog number
Clear heat-seal film	100/pkg	Thermo Fisher Scientific Matrix Technologies	AB-0685
VIEWseal™ dry film adhesive backed tape	100/pkg	Greiner Bio-One	676070

For more information about the microplates, heat-seal covers, and sealing equipment supplied by Thermo Fisher Scientific, click the following icon:



**CAUTION** Avoid using the following covers with your Accela Autosampler:

- Parafilm “M”, manufactured by American National Can, or similar material
- POWERseal™, manufactured by Greiner Bio One, or similar material
- Adhesive sealing tapes



Parafilm “M” and POWERseal covers leave small pieces of material on the needle that eventually clog the injection port. Adhesive sealing tapes leave an adhesive film on the needle causing system contamination. The adhesive builds up on the needle and in the injection port, and eventually the needle becomes completely clogged.



## Routine Maintenance

This chapter contains information on the maintenance record keeping options provided by your Thermo Scientific data system, the routine maintenance procedures necessary to optimize the performance of the autosampler, and the suggested maintenance schedule.

### Contents

- [Maintenance Schedule](#)
- [Replacing the Rotor Seal in the Valco Injection Valve](#)
- [Replacing the Inlet Filter for the Wash Bottle Solvent Line](#)
- [Replacing the Transfer Tubing](#)
- [Maintaining the Syringe Drive Assembly](#)
- [Troubleshooting a Blockage in the Injection System](#)
- [Replacing the Needle Tubing Assembly](#)
- [Replacing the Needle Assembly](#)
- [Changing the Syringe or Replacing the Inner Plunger](#)
- [Clearing a Plugged Heat Exchanger](#)
- [Replacing a Fuse](#)
- [Maintenance Cycles](#)

For your own safety and to protect the autosampler from damage, follow the safety precautions in this manual when performing maintenance on the autosampler.



**CAUTION** To avoid electrical shock, do not remove the top cover or remove parts beyond the descriptions in the operation portions or in the maintenance topics of this manual.



**CAUTION** When connecting or disconnecting solvent lines, wear safety gloves that are compatible with the solvents in the lines.

## Maintenance Schedule

The Accela Autosampler requires only a few simple maintenance procedures to keep it in optimum working condition. [Table 12](#) contains the maintenance schedule for the autosampler. A Thermo Fisher Scientific service representative or other qualified person must perform the last procedure, the alignment of the XYZ arm.

To make the maintenance of your autosampler easier, the data system keeps track of how many injections, injection valve cycles, needle cycles, and syringe cycles the autosampler has performed. The data system alerts you to perform maintenance when the number of cycles exceeds a preset value. For information on setting up the tracking system, see [“Maintenance Cycles”](#) on [page 97](#).

**Note** You are responsible for maintaining your autosampler. Routine maintenance does not fall under Thermo Fisher Scientific warranty; however, planned maintenance contracts are generally available. Contact your local representative if you are interested in purchasing a planned maintenance contract.

**Table 12.** Maintenance procedures and schedule

Frequency	Procedure	Performed by
Monthly	Checking the solvent tubing connections for leaks	User
Monthly	Running a standard sample	User
Every 15 000 to 20 000 injections	Replacing the rotor seal	User
Semiannually	Replacing the flush solvent inlet filter	User
As necessary	Replacing the injection port	User
As necessary	Clearing a plugged line or needle	User
As necessary	Changing the syringe	User
As necessary	Changing the sample loop	User
As necessary	Replacing a fuse	User
Semiannually	Cleaning and lubricating the syringe drive mechanism	User
Annually	Cleaning and lubricating the XYZ arm	Field service
Annually	Verifying the XYZ arm alignment	Field service

**Note** Table 12 lists recommended maintenance intervals based on operating the autosampler under typical conditions. Operating the autosampler under certain harsh conditions (corrosive solvents, extreme temperatures, and so on) might require more frequent maintenance than indicated in the table.

## Replacing the Rotor Seal in the Valco Injection Valve

The rotor seal is a disk with three grooves that forms a high-pressure seal with the stator. Replace the rotor seal when you notice a leak between either the stator and rotor or the adjacent ports of the injection valve, or when you notice a decrease in injection precision.

**Tip** The Valco Instruments Co. uses the term *rotor* instead of *rotor seal*. When ordering a replacement rotor seal (see Figure 43 on page 64) from Valco Instruments Co., use the term *rotor*.

This section describes how to replace the rotor seal for the autosampler's Valco injection valve. For information on replacing the rotor seal for the Rheodyne™ injection valve that shipped with earlier versions of the autosampler, see “Replacing the Rotor Seal in the Rheodyne Valve” on page 135.



**CAUTION** Before you remove the injection valve from the autosampler, turn off the power to the autosampler and unplug the autosampler from line power.



Replacing the rotor seal requires these tools.

Tool	Use
1/4 in. open-end wrench	To remove the tubing from injection valve ports 5 and 6
#2 Phillips screwdriver	To disconnect the injection valve from the autosampler
9/64 in. hex wrench	To disassemble the injection valve

**IMPORTANT** Because component cleanliness affects the useful life of the injection valve, replace the rotor seal in a clean environment.

To replace the rotor seal, follow these steps:

1. [Removing the Injection Valve from the Autosampler](#)
2. [Disassembling the Injection Valve](#)
3. [Cleaning the Stator](#)
4. [Installing a New Rotor Seal](#)
5. [Reinstalling the Injection Valve](#)

## Removing the Injection Valve from the Autosampler

Before you remove the injection valve from the autosampler, prepare a clean environment where you can disassemble the valve.

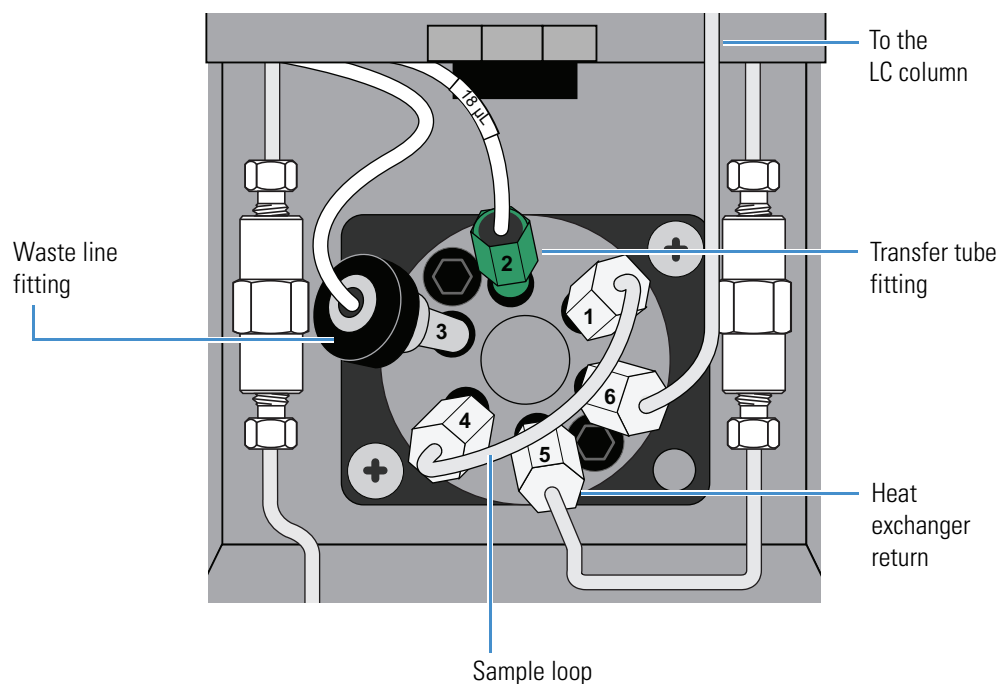
### ❖ To remove the injection valve from the autosampler

1. Disconnect the solvent lines (see [Figure 40](#)) connected to the valve as follows:
  - Disconnect the waste tubing from port 3 of the injection valve.
  - Disconnect the transfer tubing from port 2 of the injection valve.
  - Using a 1/4 in. open-end wrench, disconnect the 1/16 in. OD high-pressure tubing from ports 5 and 6.

**IMPORTANT** You do not need to remove the sample loop from the injection valve to disassemble the injection valve. Once the sample loop has been swaged onto the injection valve, the fittings are no longer interchangeable. If you do remove the sample loop from the injection valve, take note of which fitting was connected to port 1 and which fitting was connected to port 4. When you reinstall the sample loop, connect the fittings to their respective ports.

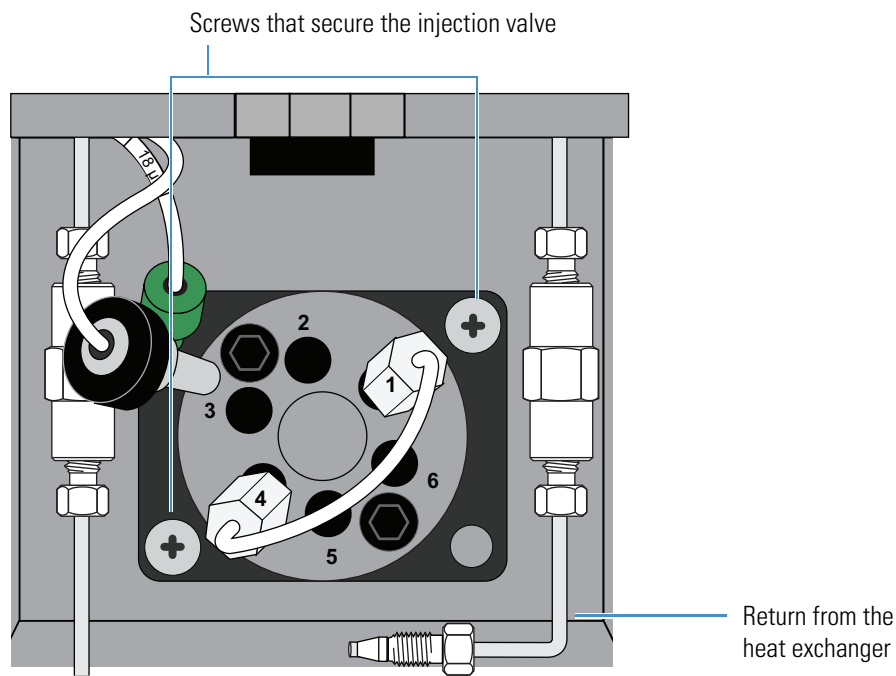
**Note** The drawings in this section show the current version of the autosampler's heat exchanger. For information about the original heat exchanger, see "[Legacy Versions of the Accela Autosampler](#)" on page 139.

**Figure 40.** Injection valve solvent line connections



- Using a #2 Phillips screwdriver, remove the two screws that secure the injection valve to the autosampler (see [Figure 41](#)).

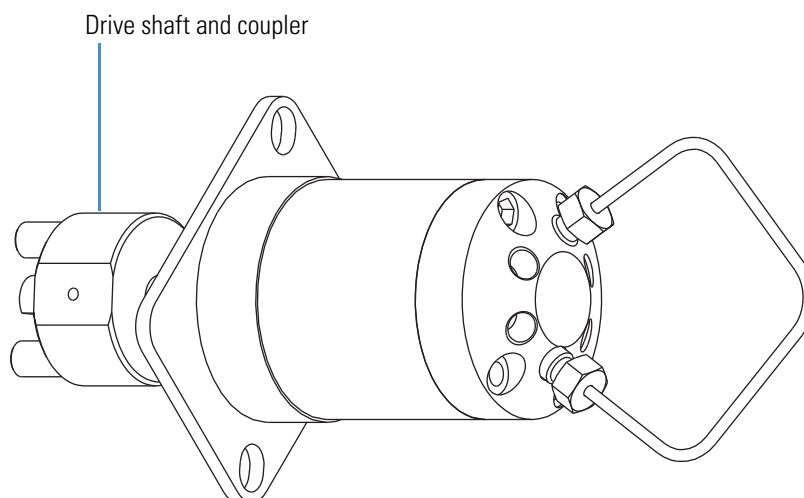
**Figure 41.** Injection valve secured to the autosampler with two screws



- Slide the injection valve forward out of the autosampler.

[Figure 42](#) shows the drive shaft and coupler on the back side of the injection valve.

**Figure 42.** Injection valve with a view of the drive shaft on the back side of the valve



## 4 Routine Maintenance

Replacing the Rotor Seal in the Valco Injection Valve

### Disassembling the Injection Valve

Leave the sample loop connected to the stator as you disassemble the injection valve.

#### ❖ To disassemble the injection valve

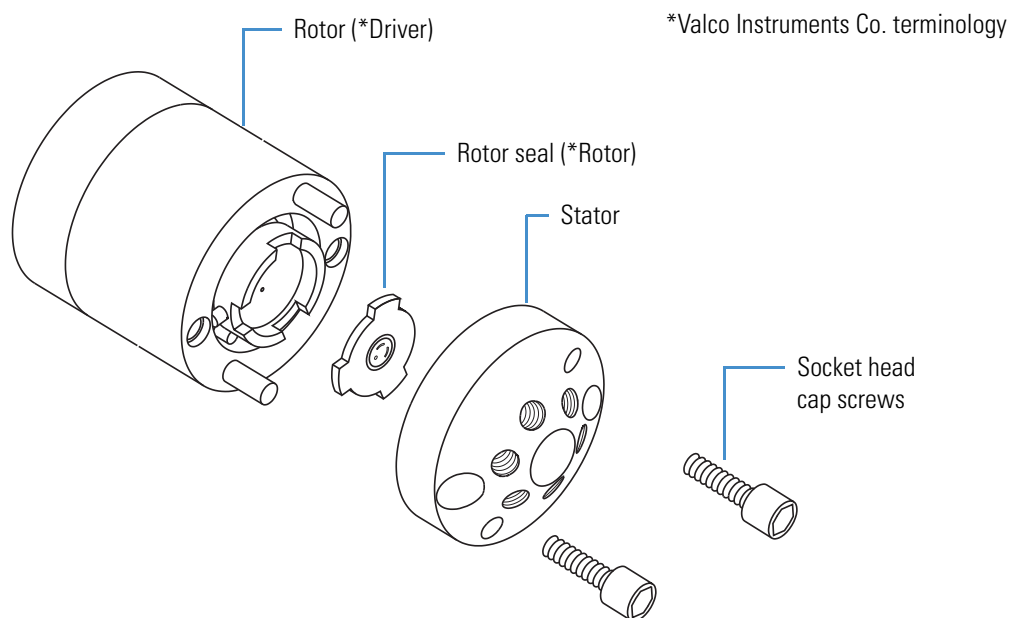
1. Using a 9/64 in. L-hex wrench, remove the two socket head cap screws that secure the stator to the driver (see [Figure 43](#)).



**CAUTION** The polished (sealing) surface of the stator contains six ports that excess handling can easily damage. As you remove the stator from the injection valve, avoid touching this polished surface, and never place the polished surface face down on a hard surface.

**Note** The Valco Instruments Co. uses the term *rotor* instead of *rotor seal* and the term *driver* instead of *rotor* (see [Figure 43](#)).

**Figure 43.** Injection valve (exploded view)



2. Gently pry the rotor seal away from the rotor (see [Figure 43](#)).
3. Examine the sealing surface of the rotor seal for scratches. If scratches are visible, replace the rotor seal.

## Cleaning the Stator

Before you replace the rotor seal, clean the stator.

### ❖ To clean the stator

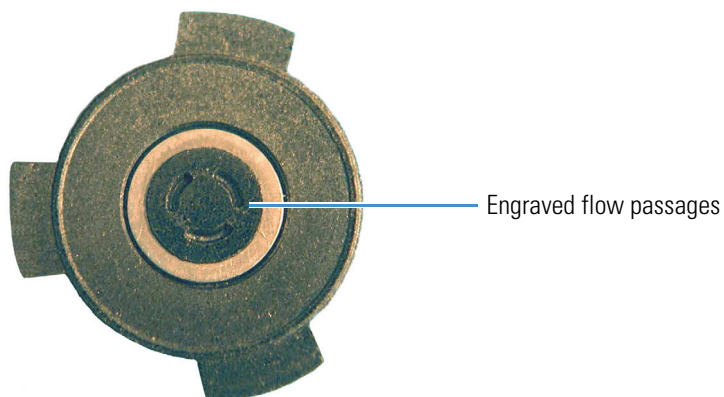
1. Inspect the stator to determine if it requires cleaning.
2. If the stator is dirty, swab it with HPLC-grade methanol. If more stringent cleaning is required, use a sonicator.
3. Inspect the remaining valve components for contamination. Clean them as necessary.

**IMPORTANT** If the stator is scratched, replace the valve. Scratches can damage the rotor seal and cause cross-port leaks.

## Installing a New Rotor Seal

The rotor seal has two sides. The side containing the engraved flow passages (see [Figure 44](#)) faces the stator.

**Figure 44.** Engraved flow passages in the Valco rotor seal



### ❖ To install a new rotor seal

1. Replace the rotor seal in the rotor, making sure that the rotor seal surface with the engraved flow passages is facing out.

The pattern is asymmetrical to prevent improper placement.

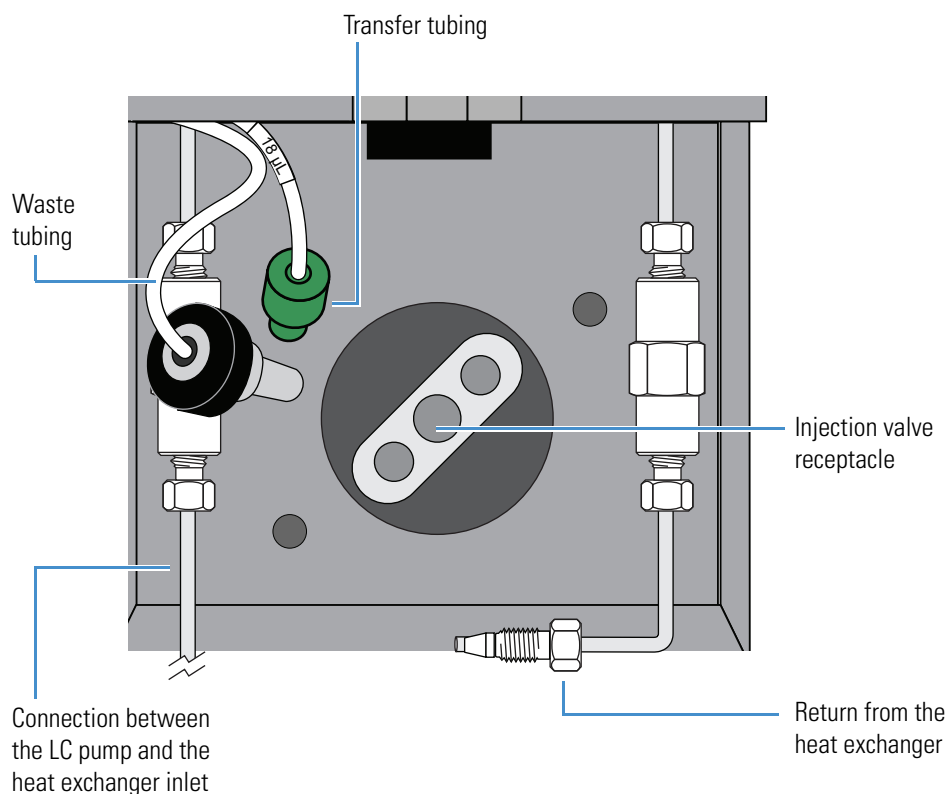
2. Replace the stator.
3. Insert the two socket head screws.
  - a. Using a 9/64 in. L-Hex wrench, tighten each screw until you feel resistance (approximately fingertight).
  - b. Tighten each screw by 1/8 turn, and then tighten each screw again, until the stator is secured to the driver. Take care not to overtighten the screws.

# Reinstalling the Injection Valve

### ❖ To reinstall the injection valve

1. Align the drive shaft (see [Figure 42](#) on [page 63](#)) and the two prongs of the coupling unit with the three holes in the injection valve receptacle located in the lower portion of the column oven compartment. Then insert the injection valve into the receptacle (see [Figure 45](#)).

**Figure 45.** Injection valve receptacle in the lower portion of the column oven compartment



2. Align the holes in the mounting plate of the injection valve with the small holes next to the injection valve receptacle.
3. Using the two screws that you removed in [step 1](#) on [page 62](#), secure the injection valve to the autosampler with a #2 Phillips screwdriver.

4. Reconnect the solvent lines to the injection valve as follows (see [Figure 45](#) on [page 66](#)):



- Hand-tighten the transfer tube fitting to port 2 and the waste tube fitting to port 3. Never use a wrench to tighten these fittings.



**CAUTION** Never use a wrench to tighten the transfer tube fitting. Over-tightening the fitting can do the following:

- Restrict the end of the tubing, which leads to less sample reaching the sample loop and results in smaller than expected peak areas or blank injections. A restriction in the end of the tubing can also cause the syringe to make a grinding sound during an injection sequence.
  - Strip the threads on the fitting, which leads to solvent leaks.
- Press the end of the return tubing from the heat exchanger to the bottom of port 5 as you hand-tighten the high-pressure fitting. Then use a wrench to tighten the fitting by an additional 1/4 turn.
  - Using high-pressure tubing and two high-pressure fittings, reconnect the LC column to port 6 of the injection valve.

**Note** To reconnect tubing with a pre-swaged stainless steel fitting to a valve port, hand-tighten the fitting as you press the tubing against the bottom of the port, and then use a wrench to tighten the fitting by an additional 1/4 to 1/2 turn.

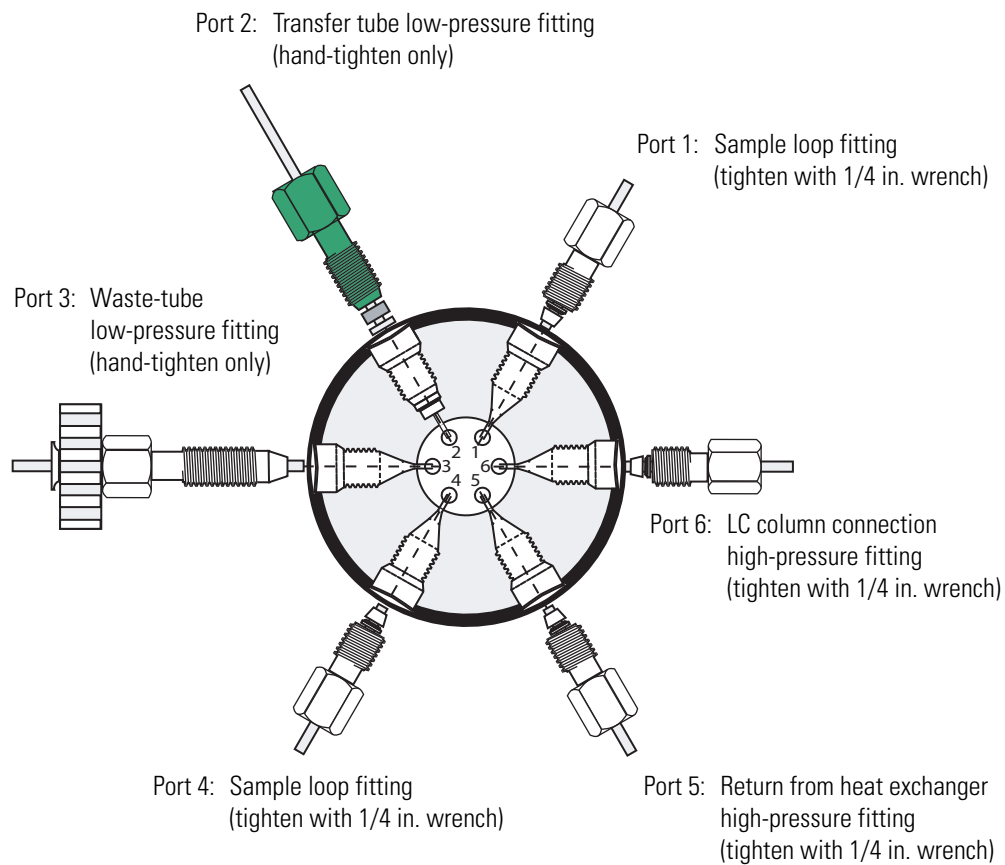
To connect tubing with a two-piece stainless steel fitting to a mating port, press the tubing against the bottom of the port as you hand-tighten the fitting. Then tighten the fitting by an additional 3/4 turn with a wrench. Once you use the wrench to tighten the fitting, the ferrule portion of the two-piece fitting is permanently connected to the tubing.

- If you removed the sample loop, connect the appropriate ends of the sample loop to ports 1 and 4.

## 4 Routine Maintenance

Replacing the Rotor Seal in the Valco Injection Valve

**Figure 46.** Schematic of the tubing connections to the injection valve



5. Turn on the pump flow and check for leaks.

## Replacing the Inlet Filter for the Wash Bottle Solvent Line

Properly filtering the flush solvent extends the life of the injection valve and the LC column.

### ❖ To replace the inlet filter

1. Be sure the autosampler is in Idle mode.
2. Remove the flush-solvent bottle cap and lift out the inlet tubing.
3. Remove the old inlet filter.



**CAUTION** Be sure to follow all of the safety precautions for each solvent, as prescribed by the MSDS.

4. Install a new filter, and then put the line back into the bottle. Tighten the solvent cap.
5. Flush the inlet filter and lines with an appropriate volume of solvent.

## Replacing the Transfer Tubing

The transfer tubing that connects the injection port of the autosampler to port 2 of the injection valve can become worn, damaged, or plugged with use.

Replace the transfer tubing if it becomes plugged or if your injections become less reproducible (which can indicate of a worn or damaged transfer tube). In addition, replace the transfer tubing when you replace the needle.

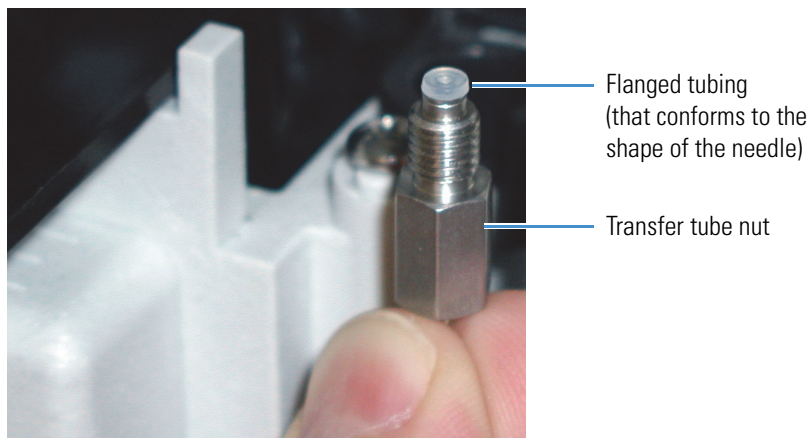
The transfer tubing assembly consists of two fittings and a 9 in. length of 0.012 in. ID tubing (see [Figure 47](#)). The stainless steel nut connects to the autosampler injection port and the green PEEK fitting connects to port 2 of the injection valve. The label near the PEEK fitting end of the tubing specifies the internal volume of the tubing.

**Figure 47.** Transfer tubing assembly



**Tip** Because the flanged end of the transfer tubing (see [Figure 48](#)) conforms to the shape of the needle, it is good practice to replace the transfer tubing when you replace the needle. The reverse is not true. The tip of the needle does not conform to the shape of the transfer tube fitting, so you do not need to replace the needle when you replace the transfer tubing.

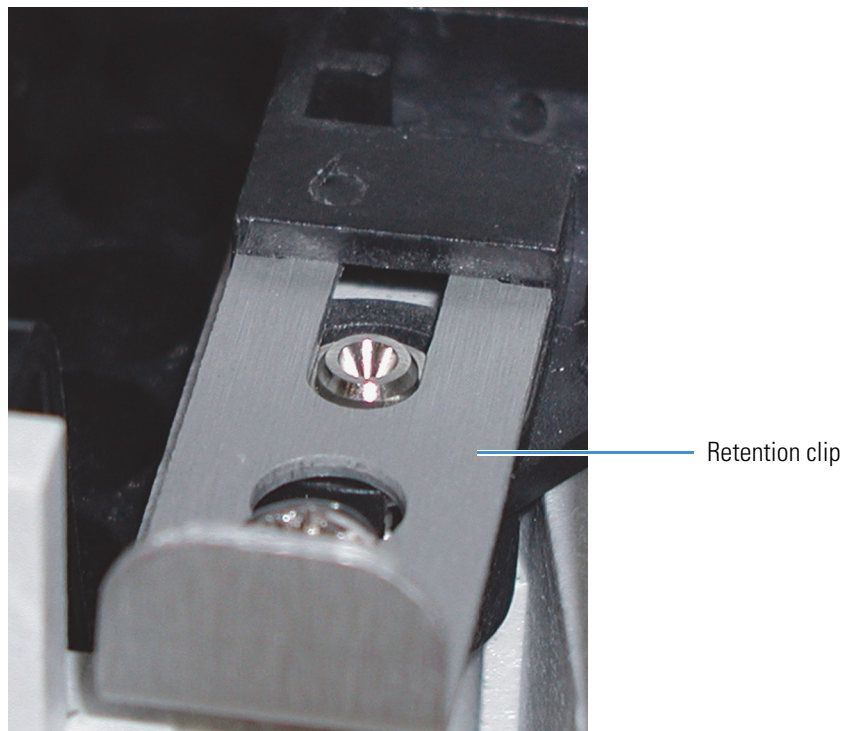
**Figure 48.** Transfer tube nut and flanged end of the transfer tubing



❖ **To replace the transfer tubing**

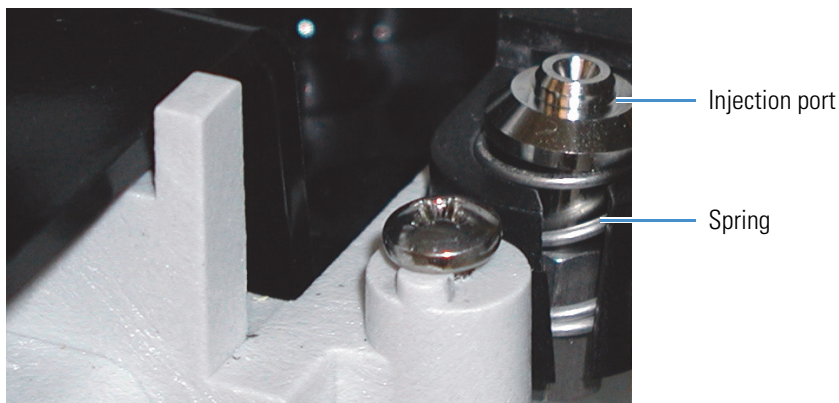
1. To remove the aluminum retention clip (see [Figure 49](#)) from the wash station housing, pull it forward and then upward.

**Figure 49.** Retention clip for the injection port



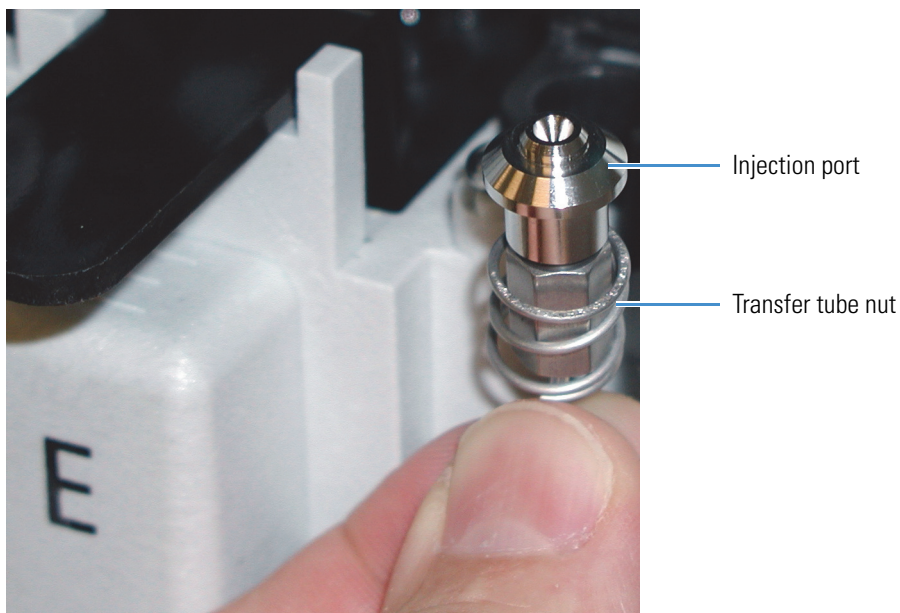
2. Pull the injection port out from the wash station (see [Figure 50](#)).

**Figure 50.** Injection port seated in the wash station



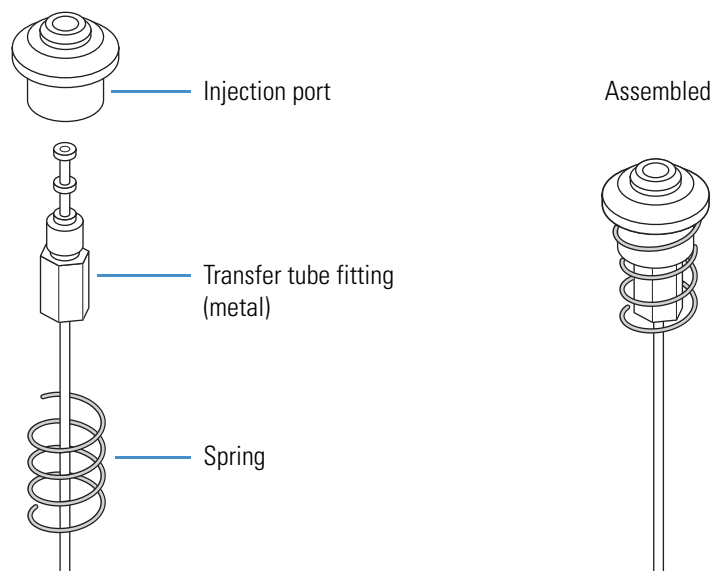
3. Unscrew the transfer tube nut from the injection port fitting (see [Figure 51](#)) and from port 2 of the injection valve, and then pull the tubing to the left through the hole in the wall between the tray compartment and the oven compartment (see [Figure 10](#) on [page 11](#)). Discard the used transfer tube.

**Figure 51.** Injection port connected to the transfer tube nut



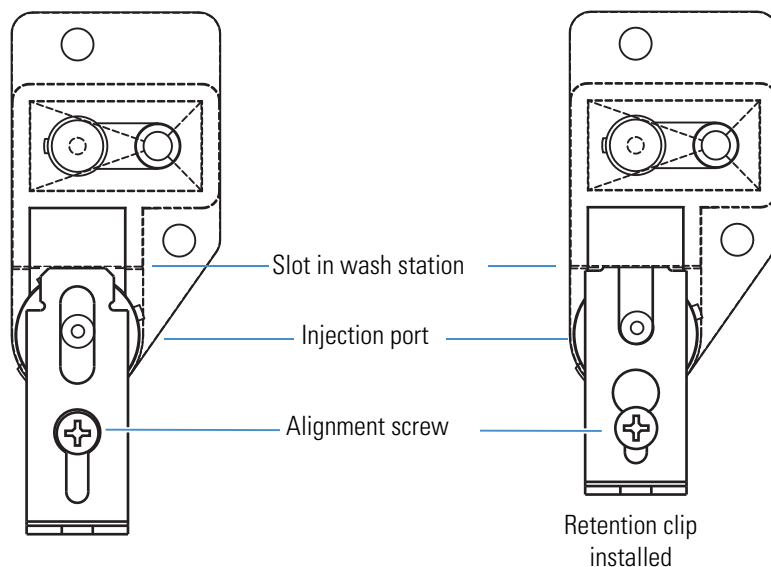
4. Screw the injection port onto the nut of the new transfer tubing.
5. Set the injection port into the spring (see [Figure 52](#)). Then insert it into the port in front of the wash station.

**Figure 52.** Transfer tubing, spring, and injection port



6. Reinstall the retention clip (see [Figure 53](#)) as follows:
  - a. Align the retention clip with the slot located in front of the wash station.
  - b. Using the retention clip to push the injection port down, align the circular cutout in the retention clip over the alignment screw.
  - c. Insert the end of the retention clip into the wash station slot as far as it will go.

**Figure 53.** Retention clip installation



7. Route the other end of the transfer tube through the hole in the wall between the tray and column oven compartments (see [Figure 10](#) on [page 11](#)).



8. Taking care to avoid overtightening, hand-tighten the fitting to port 2 of the injection valve. Never use a wrench to tighten this fitting.



**CAUTION** Never use a wrench to tighten the transfer tube fitting. Overtightening constricts the transfer tube, causing poor injection precision or blank injections. Eventually, the damaged transfer tube becomes completely plugged.

**IMPORTANT** You must modify the instrument configuration by entering the new value for the internal volume of the transfer tubing. For instructions on updating the instrument configuration for the autosampler, refer to the data system Help.

9. Modify the instrument configuration for the internal volume of the new transfer tube.

For information on specifying the volume of the transfer tubing, refer to the data system Help.

## Maintaining the Syringe Drive Assembly

If you have an older version of the Accela Autosampler with an uncoated, stainless steel lead screw, as a part of routine maintenance, lubricate the lead screw once every six months or as needed. If the syringe drive skips steps and does not return to the home position after you perform a Flush Syringe direct command, lubricate the lead screw before you continue operation.

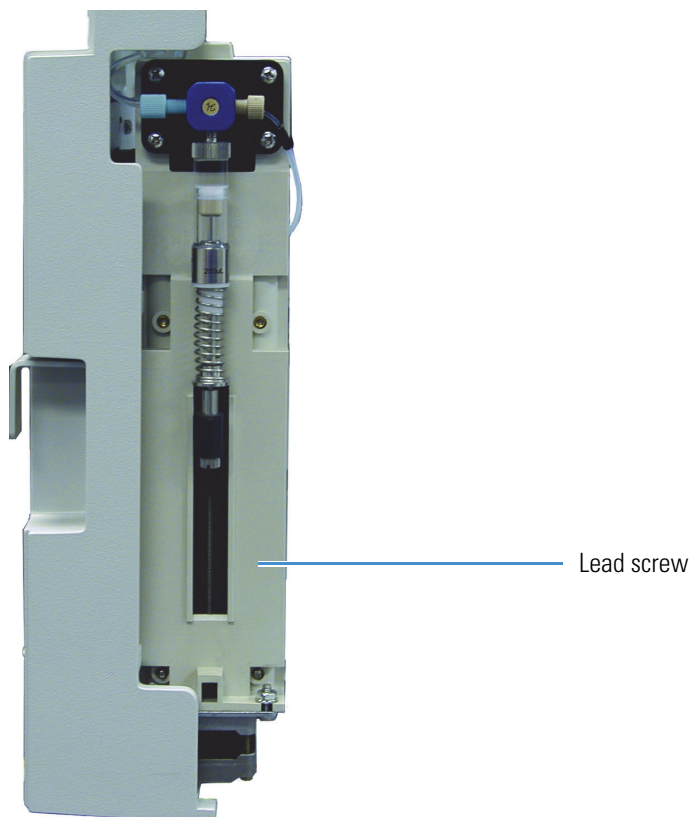
**Note** The syringe drive assembly in the current version of the Accela Autosampler does not require routine maintenance. The lead screw is coated with black Teflon and the drive nut is made of plastic, so there is minimal friction between these moving parts.

## 4 Routine Maintenance

### Maintaining the Syringe Drive Assembly

Figure 54 shows the uncoated, stainless steel lead screw in an older version of the Accela Autosampler.

**Figure 54.** Syringe drive assembly with an uncoated, stainless steel lead screw



Lubricating the lead screw requires these tools and materials:

#### Tools and materials

Flat-head screwdriver

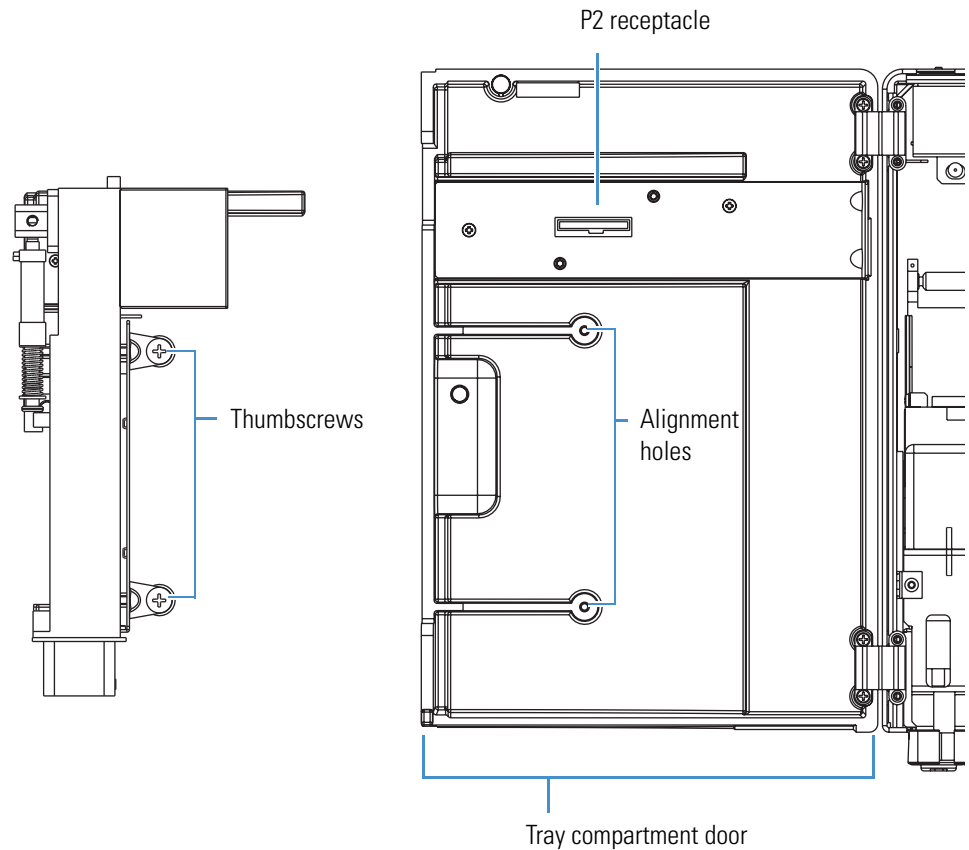
Tri-Flow™ lubricant (For ordering information, see Lubricant in the list of “Consumables” on page 124.)

#### ❖ To clean and lubricate the lead screw of the syringe drive assembly

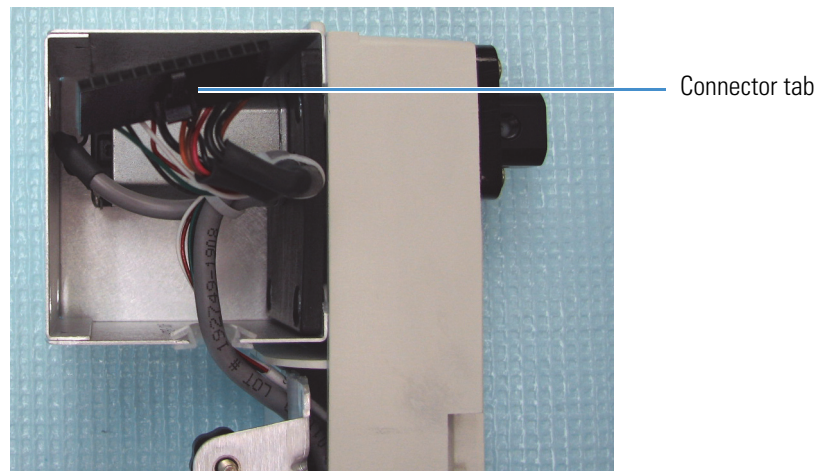
1. Remove the syringe drive assembly from the autosampler as follows:
  - a. To prevent siphoning of the wash solvent, lower the wash bottle below the level of the syringe valve by removing the wash bottle from the solvent platform and placing it on the countertop next to the Accela LC stack.
  - b. Disconnect the needle tubing from the right side of the syringe valve.
  - c. Disconnect the wash tubing from the left side of the syringe valve.

- d. Remove the two thumbscrews that connect the syringe drive assembly to the inner side of the tray compartment door (see [Figure 55](#)).
- e. To disconnect the cable that is routed through the back of the syringe drive assembly and connected to the P2 receptacle on the inner side of the tray compartment door, press the connector tab (see [Figure 56](#)) and pull the connector out of the receptacle.

**Figure 55.** Syringe drive assembly disconnected from the inner side of the door



**Figure 56.** Syringe drive assembly cable



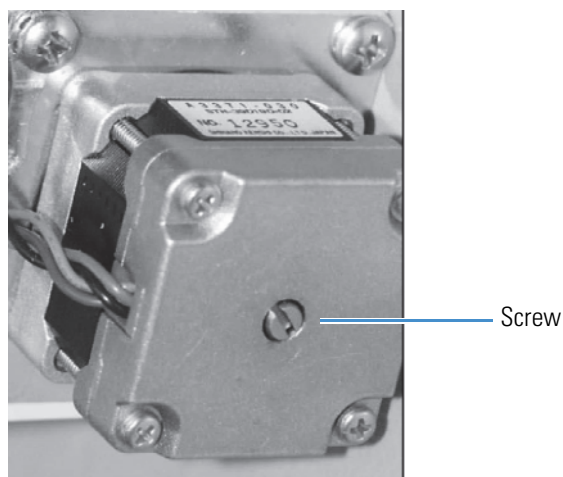
## 4 Routine Maintenance

### Maintaining the Syringe Drive Assembly

**Note** You can lubricate the lead screw without removing the base plate from the back of the syringe drive assembly.

2. Lubricate the lead screw as follows:
  - a. Through the cutout in the front of the syringe drive assembly, apply 2 to 3 drops of Tri-Flow lubricant to the top part of the lead screw.
  - b. Using a flat head screwdriver, turn the screw at the bottom of the motor (see [Figure 57](#)) counterclockwise until the arm is at the top position.

**Figure 57.** Screw at the bottom of the syringe drive motor



- c. Apply lubricant to the bottom part of the lead screw.
3. Reconnect the syringe drive assembly to the autosampler as follows:
  - a. Plug the syringe drive assembly cable into the P2 receptacle on the inner side of the tray compartment door.
  - b. Realign the syringe drive assembly with the alignment holes on the inner side of the tray compartment door (see [Figure 55](#) on [page 75](#)).
  - c. Using the two thumbscrews that you removed in [step 1d](#) on [page 75](#), secure the syringe drive assembly to the door.
  - d. Reconnect the needle tubing to the right side of the syringe valve.
  - e. Reconnect the wash tubing to the left side of the syringe valve.
4. Set the syringe to its home position (see [“Setting the Syringe to the Home Position”](#) on [page 93](#)).

5. To ensure that the lead screw has been properly lubricated, set up the autosampler as follows and watch the movement of the syringe as the autosampler flushes the syringe:
  - a. Fill the wash bottle with HPLC-grade water.
  - b. Perform a **Flush Syringe** direct command using these values:

Parameter	Value
Reservoir	Flush Bottle (Xcalibur data system or Tune window) Bottle (ChromQuest data system)
Volume ( $\mu\text{L}$ )	6000
Flush Speed ( $\mu\text{L}/\text{sec}$ )	100

If the lead screw has been properly lubricated, it does not stall as the autosampler flushes water through the system at a speed of 100  $\mu\text{L}/\text{sec}$ .

6. Refill the wash bottle with an appropriate solvent mixture for your applications.

## Troubleshooting a Blockage in the Injection System

A blocked tubing or a plugged needle can cause the syringe drive to stall. A stalled syringe drive makes a grinding sound because the syringe motor must overcome a greater force to move the plunger.

If the injection system has a plug (as indicated by an abnormally loud grinding sound made by the syringe drive), determine where the plug is located by systematically checking the following sections of the injection system (see [Figure 58](#)):

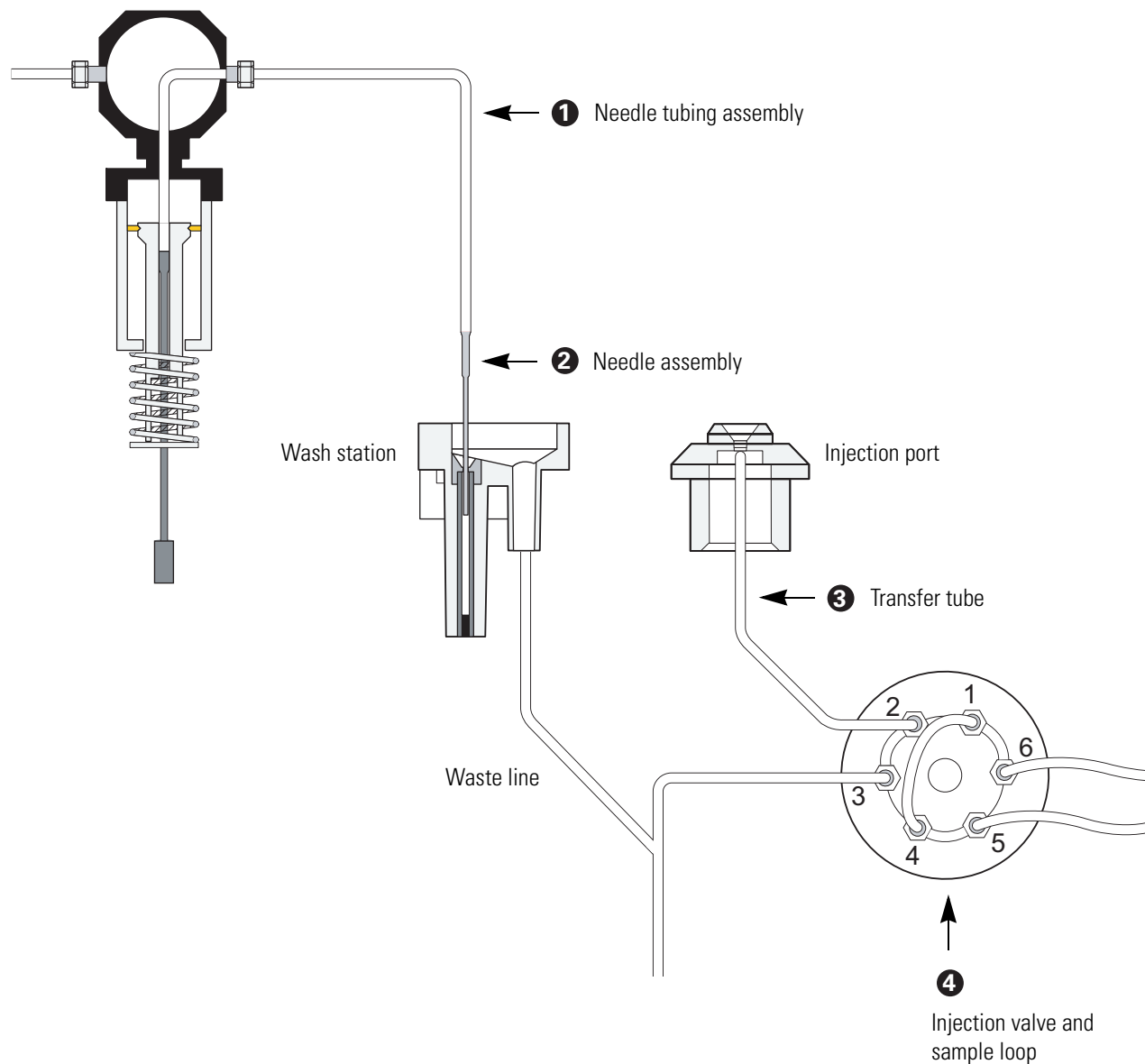
- Section 1: Needle tubing assembly
- Section 2: Needle assembly
- Section 3: Transfer tubing
- Section 4: Injection valve and sample loop

**Tip** The transfer tube, needle, and small ports in the stator of the injection valve are the most commonly plugged components of the injection system. A damaged syringe valve can also reduce the solvent flow and cause a grinding sound.

## 4 Routine Maintenance

Troubleshooting a Blockage in the Injection System

**Figure 58.** Possible locations of a plug



To find and clear a plug, follow these steps until you find the blockage:

1. [Testing the Needle Tubing and the Syringe Valve for Blockage](#)
2. [Testing the Needle for Blockage](#)
3. [Testing the Transfer Tube for Blockage](#)
4. [Cleaning the Injection Valve or the Sample Loop](#)

## Testing the Needle Tubing and the Syringe Valve for Blockage

### ❖ To test the needle tubing for blockage

1. Move the XYZ arm to the front-center of the tray compartment (see “[Setting the Needle to the Removal Position](#)” on [page 83](#)).
  2. Unscrew the needle tubing assembly from the needle assembly (see [Figure 4](#) on [page 6](#)) and place the needle tubing fitting into a beaker.
  3. As you perform a **Wash Needle** direct command with a 2000 µL volume, observe the solvent flow and listen for a grinding sound from the syringe drive.
  4. Depending on whether solvent flows freely out the end of the needle tubing and you hear a grinding sound from the syringe drive, do one of the following:
    - If the wash solvent flows out of the needle tubing at a normal rate and you do not hear a grinding sound, the needle tubing is not the source of blockage. Skip [step 5](#) and [step 6](#) and go to the next procedure to test the needle for blockage.
- or–
- If the flow appears to be constricted, go to [step 5](#).
5. Verify that the syringe valve is not the cause of the constricted flow:
    - a. Unscrew the needle tubing from the right side of the syringe valve.
    - b. Perform a **Wash Needle** direct command using a 2000 µL volume, and observe the solvent flow out of the right side of the syringe valve.
    - c. Depending on whether solvent flows freely out of the right side of the syringe valve, do one of the following:
      - If solvent flows out of the right side of the syringe valve, replace the needle tubing, which was the source of the blockage.
      - If solvent does not flow out of the right side of the syringe valve, replace the syringe valve.
  6. After you replace the syringe valve or the needle tubing, home the position of the syringe (see “[Setting the Syringe to the Home Position](#)” on [page 93](#)).

If the needle tubing was not the blockage source, go to the next procedure, “[Testing the Needle for Blockage](#).”

### Testing the Needle for Blockage

#### ❖ To test the needle for blockage

1. Remove the needle from the needle mount on the XYZ arm by pulling the latch nut of the needle assembly forward, and then pulling the needle up out of the needle mount.
2. Reconnect the needle tubing to the needle.
3. Holding the needle over the beaker, perform a **Wash Needle** direct command using a 2000  $\mu\text{L}$  volume. Watch how freely solvent flows from the end of the needle, and listen for a grinding sound from the syringe drive.
4. Depending on whether solvent flows freely out of the end of the needle and you hear a grinding sound from the syringe drive, do one of the following:
  - If the solvent flow is constricted, the needle is constricted.

–or–

  - If solvent flows out of the end of the needle at a normal rate and you do not hear a grinding sound from the syringe drive, the needle is not the source of blockage. Go to [step 6](#).
5. To remove the needle blockage, run a clean wire through the needle or replace the needle as described in [“Replacing the Needle Tubing Assembly”](#) on [page 83](#). After you replace the needle assembly, set the syringe to its home position.
6. If the needle is not the source of blockage, reconnect the injection system as follows:
  - a. Disconnect the needle from the needle tubing.
  - b. Move the XYZ arm to the front-center of the tray compartment (see [“Setting the Needle to the Removal Position”](#) on [page 83](#)).
  - c. Insert the needle into the needle mount on the XYZ arm, and then push the latch nut backward.
  - d. Reconnect the needle tubing to the needle, and then ensure that the needle tubing is routed through the appropriate brackets (see [“Replacing the Needle Tubing Assembly”](#) on [page 83](#)).

If the needle was not the blockage source, go to the next procedure, [“Testing the Transfer Tube for Blockage.”](#)

## Testing the Transfer Tube for Blockage

### ❖ To test the transfer tube for blockage

1. Disconnect the transfer tube from port 2 of the injection valve (see [Figure 58](#) on [page 78](#)).
2. Place the free end of the transfer tube into a beaker to collect solvent.
3. As you perform a **Flush Syringe** direct command, listen for an abnormally loud grinding sound.
  - If the syringe drive does not stall, then the plug is in the injection valve or the sample loop. Reconnect the transfer tube to port 2 of the injection valve and go to the next procedure, [“Cleaning the Injection Valve or the Sample Loop.”](#)
  - If the solvent flow is constricted through the transfer tube, replace the transfer tube (see [“Replacing the Transfer Tubing”](#) on [page 69](#)).
4. After you replace the transfer tube, home the position of the syringe (see [“Setting the Syringe to the Home Position”](#) on [page 93](#)).

If the transfer tube was not the blockage source, go to the next procedure, [“Cleaning the Injection Valve or the Sample Loop.”](#)

## Cleaning the Injection Valve or the Sample Loop

If the blockage was not in the needle tubing assembly or the transfer tube, it must be in either the injection valve or the sample loop. Clear the blockage, and then set the syringe to the home position.



**CAUTION** Do not clean the injection valve with a cleaning wire, which can damage the valve.

### ❖ To clear the blockage from the sample loop

1. Remove the sample loop from the valve.
2. Clear blockage from the sample loop by pushing a wire through it. Or, connect a new sample loop to the valve.
3. After you reconnect the sample loop, home the position of the syringe.

#### ❖ To clear the blockage from the injection valve

1. Remove the sample loop from the valve (see “[Changing the Sample Loop](#)” on page 48).
2. Remove the valve from the autosampler (see “[Removing the Injection Valve from the Autosampler](#)” on page 62).
3. Disassemble the valve (see “[Disassembling the Injection Valve](#)” on page 64).



**CAUTION** The polished (sealing) surface of the stator contains six ports that excess handling can easily damage. As you remove the stator from the injection valve, avoid touching this polished surface, and never place the polished surface face down on a hard surface.

4. Place the stator (with the front face down) and the rotor seal side-by-side in a beaker. Fill the beaker with HPLC-grade methanol or acetonitrile, and then place the beaker in an ultrasonic bath and sonicate for approximately 10 minutes.
5. Reassemble the valve (see “[Installing a New Rotor Seal](#)” on page 65).
6. Reinstall the valve (see “[Reinstalling the Injection Valve](#)” on page 66).
7. After you clear the source of the blockage, home the position of the syringe (see “[Setting the Syringe to the Home Position](#)” on page 93).

## Replacing the Needle Tubing Assembly

The needle tubing assembly connects the solvent path between the needle and the syringe valve.



**CAUTION** The needle tubing is easily damaged. Before you operate the autosampler, take care to route the needle tubing through the support brackets.

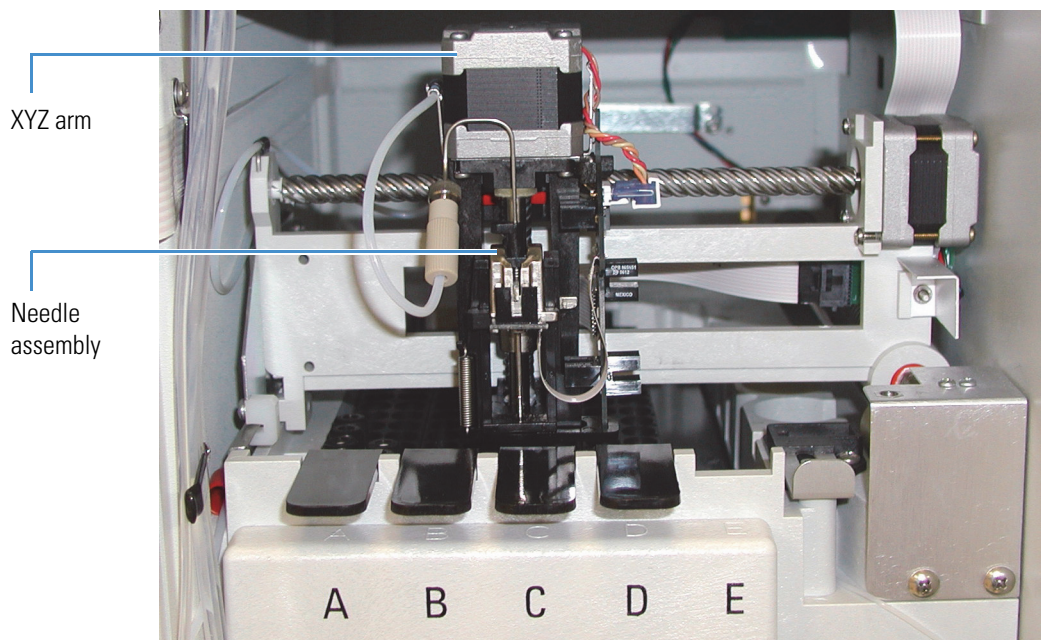
To replace the needle tubing assembly, follow these steps:

1. [Setting the Needle to the Removal Position](#)
2. [Removing the Needle Tubing Assembly](#)
3. [Installing the Needle Tubing Assembly](#)
4. [Setting the XYZ Arm to the Home Position](#)

### Setting the Needle to the Removal Position

Setting the needle to the removal position moves the XYZ arm to the front-center of the tray compartment and lowers the needle one inch (see [Figure 59](#)).

**Figure 59.** XYZ arm set to the front center of the tray compartment



#### ❖ To set the needle to the removal position

Do the following:

- For the Xcalibur data system, open the Direct Control dialog box for the autosampler (see [“Using the Xcalibur Direct Control Commands”](#) on page 141). Select **Needle Removal**, and then click **Apply**.
- For the ChromQuest data system, open the Direct Controls page for the autosampler (see [“Using the ChromQuest Direct Commands”](#) on page 143). Select **Position Arm to Replace Needle**, and then click **Submit**.

To replace the needle tubing assembly, go to the next procedure, [“Removing the Needle Tubing Assembly.”](#)

## Removing the Needle Tubing Assembly

#### ❖ To remove the needle tubing assembly

1. Move the XYZ arm to the front center of the tray compartment (see [“Setting the Needle to the Removal Position”](#) on page 83).
2. Unscrew the needle tubing from the needle assembly.
3. Remove the needle tubing from the bracket on the XYZ arm (see [Figure 61](#) on page 86).
4. Pull the two-pronged needle tubing guide out of the *x*-axis positioning frame (see [Figure 62](#) on page 86).
5. Move the XYZ arm to the back of the tray compartment (see [“Moving the XYZ Arm to the Back of the Tray Compartment”](#) on page 51).
6. Remove the needle tubing from the bracket on the left wall of the tray compartment (see [Figure 63](#) on page 87).
7. Remove the needle tubing from the bracket on the inside of the tray compartment door (see [Figure 65](#) on page 88).
8. Pull the tubing out of the tray compartment. A black or red PVC cap keeps the tubing positioned below the metal runner for the *x*-axis positioning frame.
9. Unscrew the needle tubing from the right side of the two-way syringe valve (see [Figure 66](#) on page 88).

Go to the next procedure, [“Installing the Needle Tubing Assembly.”](#)

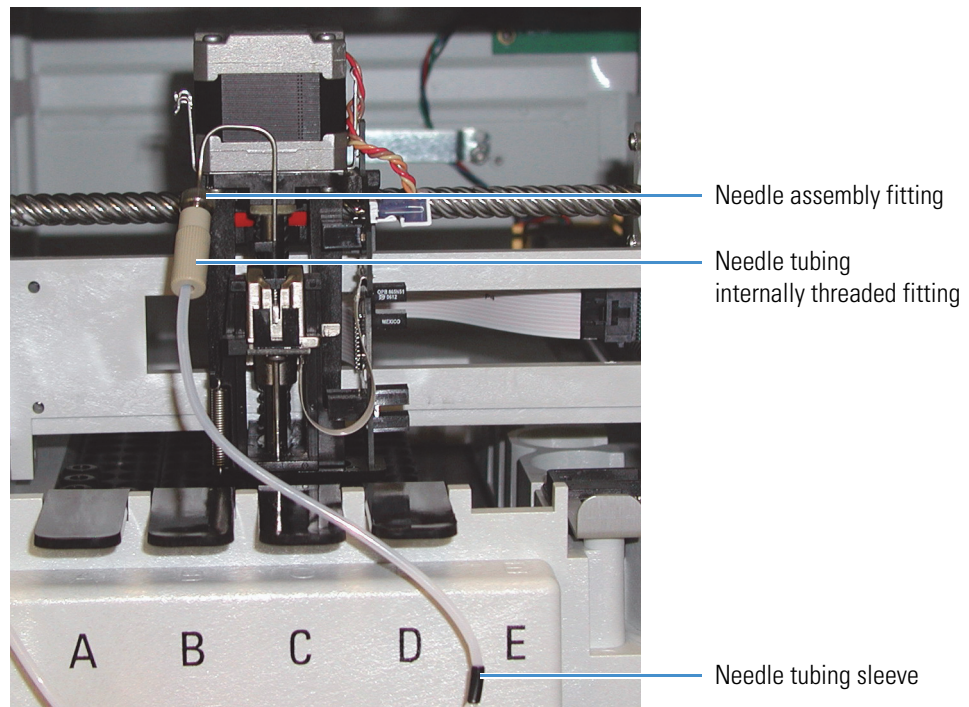
## Installing the Needle Tubing Assembly

### ❖ To install a new needle tubing assembly

1. Connect the internally-threaded fitting of the needle tubing assembly to the needle assembly fitting (see [Figure 60](#)).
2. Verify that the length of tubing between the internally threaded fitting and the black sleeve is approximately 16.5 cm (6.5 in.) in length (see [Figure 60](#)).

**Tip** When the needle tubing assembly is connected to the needle assembly, the distance between the needle tubing fitting and the letter E on the tray compartment is approximately 16.5 cm (6.5 in.).

**Figure 60.** Appropriate length of tubing between the needle tubing fitting and the needle tubing sleeve



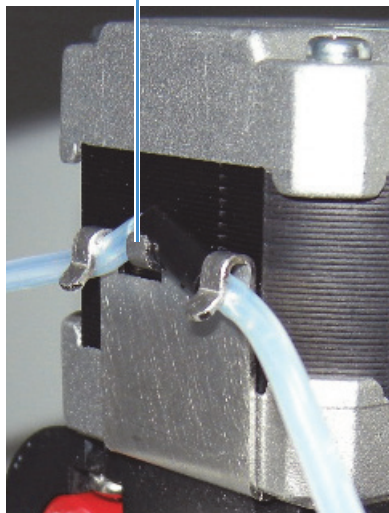
## 4 Routine Maintenance

### Replacing the Needle Tubing Assembly

3. Route the needle tubing through the bracket on the XYZ arm. Seat the black sleeve in the middle of the bracket (see [Figure 61](#)).

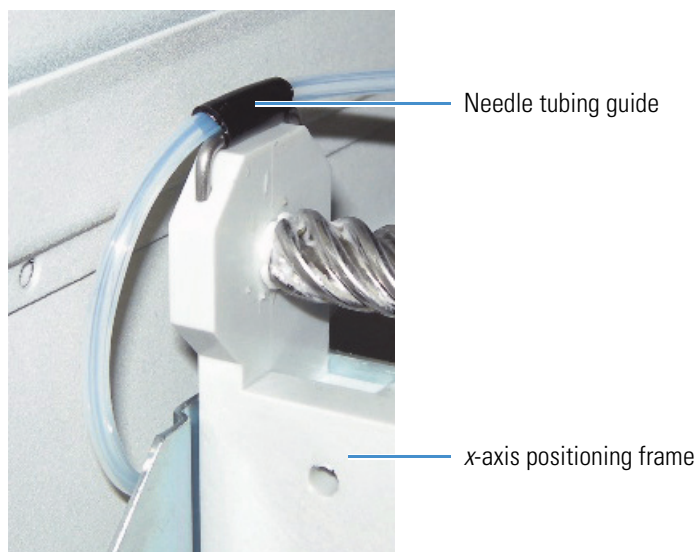
**Figure 61.** Needle tubing routed through the bracket on the XYZ arm

Bracket on the XYZ arm



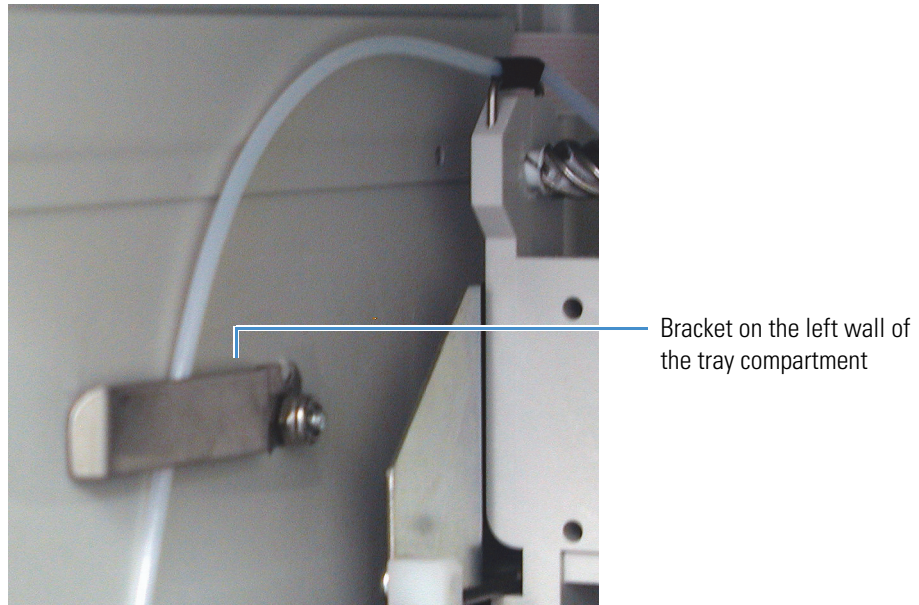
4. Insert the prongs of the needle tubing guide into the alignment holes in the *x*-axis positioning frame (see [Figure 62](#)).

**Figure 62.** Needle tubing guide inserted into the alignment holes in the *x*-axis frame



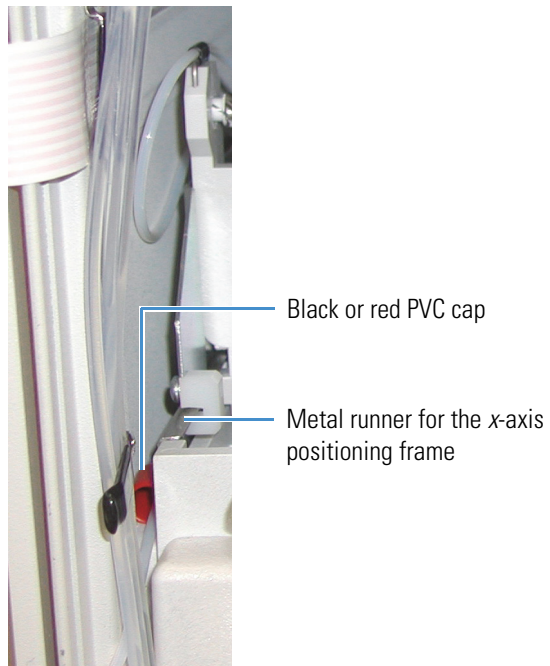
5. Move the XYZ arm to the back of the tray compartment (see [“Moving the XYZ Arm to the Back of the Tray Compartment”](#) on [page 51](#)).
6. Route the needle tubing through the bracket on the left wall of the tray compartment (see [Figure 63](#)).

**Figure 63.** Bracket on the left wall of the tray compartment



7. Push the black or red PVC cap (that is attached to the needle tubing assembly) below the metal runner for the *x*-axis positioning frame (see [Figure 64](#)).

**Figure 64.** Black or red PVC cap that keeps the needle tubing below the metal runner of the *x*-axis positioning frame

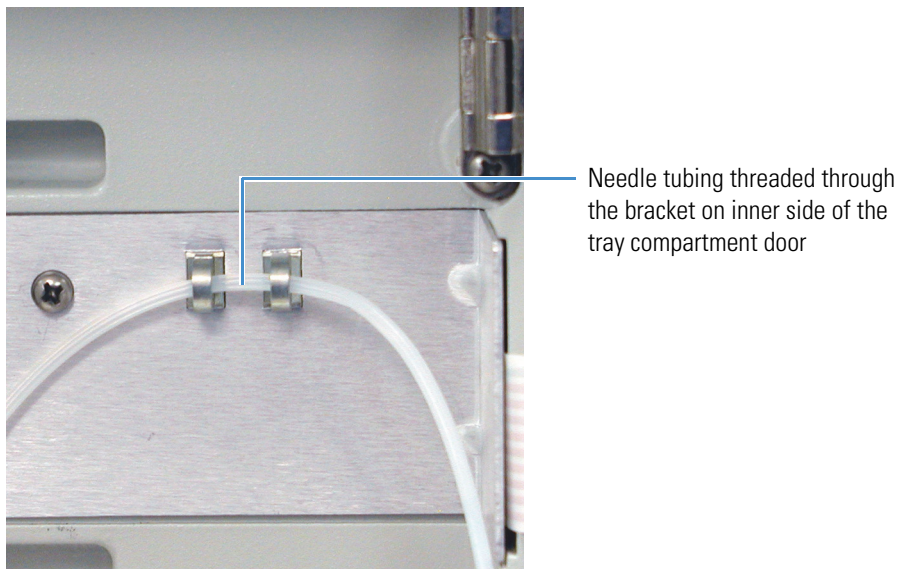


## 4 Routine Maintenance

### Replacing the Needle Tubing Assembly

8. Route the needle tubing through the bracket on the inside of the tray compartment door (see [Figure 65](#)).

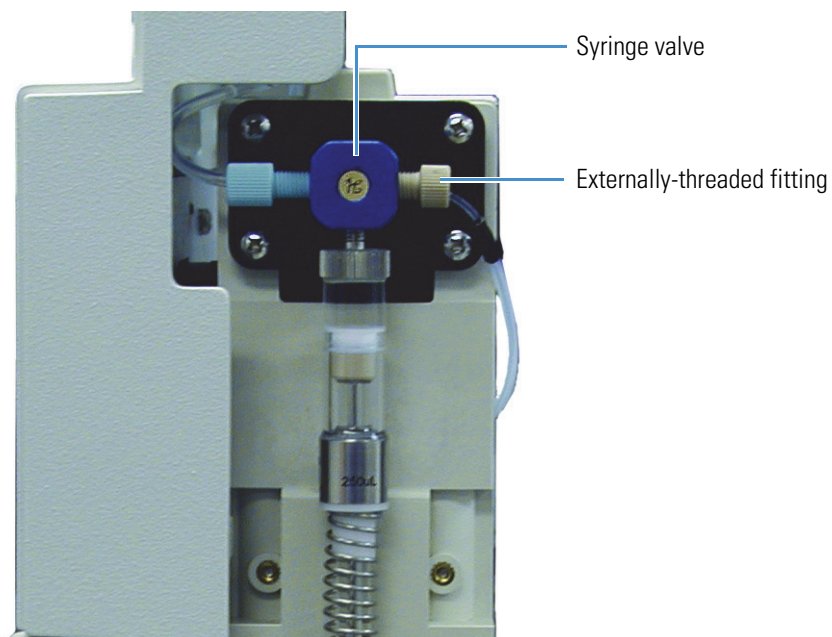
**Figure 65.** Bracket on the inside of the tray compartment door



**Note** The bracket on the tray compartment door of your autosampler might look different from the bracket shown in [Figure 65](#).

9. Connect the externally threaded fitting of the needle tubing fitting to the right side of the syringe valve (see [Figure 66](#)).

**Figure 66.** Needle tubing connected to the right side of the syringe valve



Go to the next procedure, “[Setting the XYZ Arm to the Home Position.](#)”

## Setting the XYZ Arm to the Home Position

To set the XYZ arm to the home position, use the appropriate command from the data system.

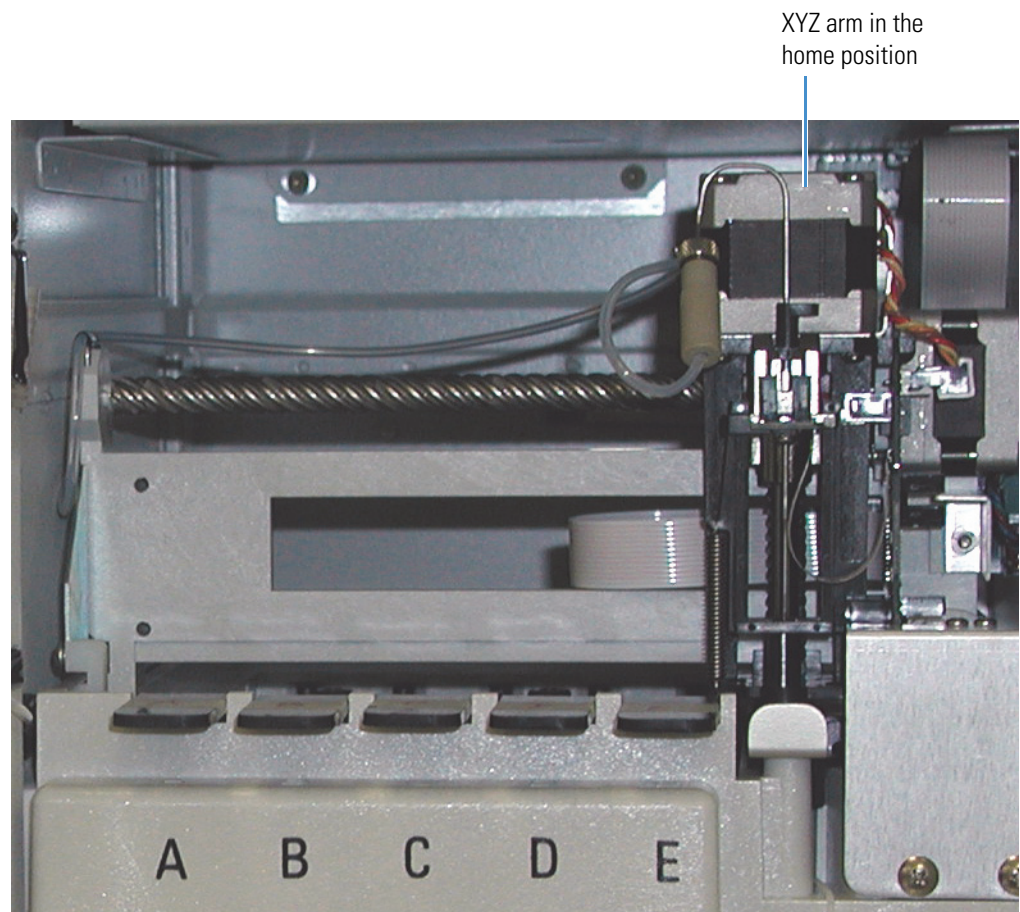
### ❖ To set the XYZ arm to the home position

Do the following:

- For the Xcalibur data system, open the Direct Control dialog box for the autosampler (see “Using the Xcalibur Direct Control Commands” on page 141). Select **Set Arm to Home Position**, and then click **Apply**.
- For the ChromQuest data system, open the Direct Controls page for the autosampler (see “Using the ChromQuest Direct Commands” on page 143). Select **GoTo Home**, and then click **Submit**.

The home position of the XYZ arm is directly behind the wash station (see Figure 67).

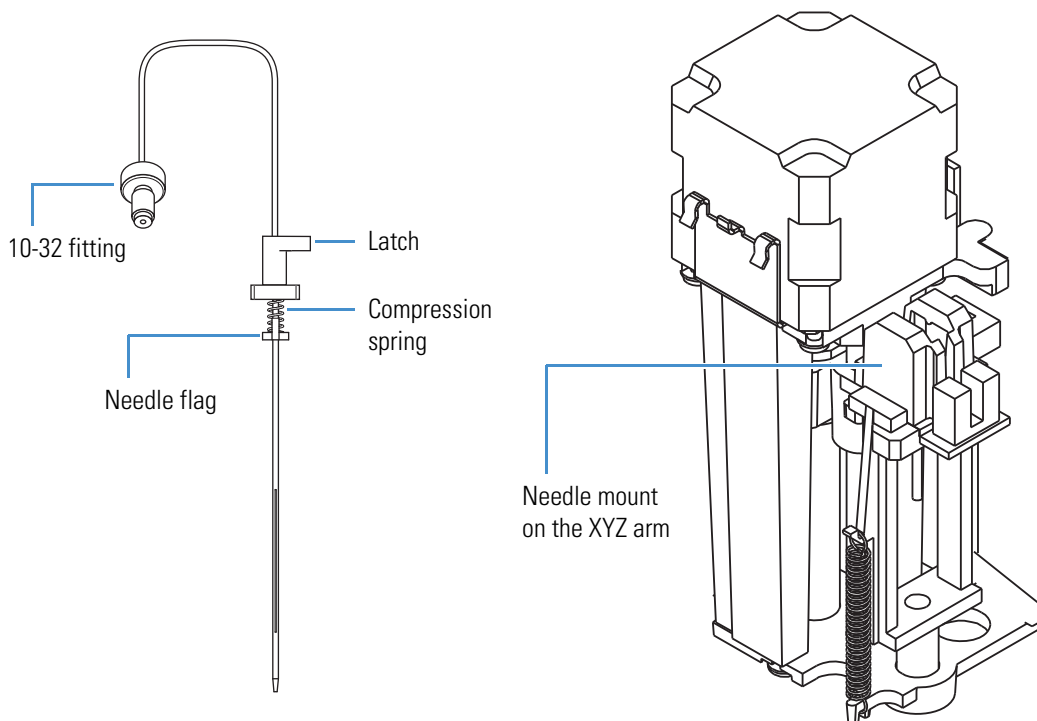
**Figure 67.** XYZ arm in the home position



## Replacing the Needle Assembly

The needle assembly is a welded piece of 0.012 in. ID stainless steel tubing with an externally-threaded fitting, a needle flag, a latch, and a compression spring (see [Figure 68](#)). It slides into the needle mount on the XYZ arm and is secured with the latch.

**Figure 68.** Needle assembly



### ❖ To replace the needle assembly

1. Move the XYZ arm to the front-center of the tray compartment (see [“Setting the Needle to the Removal Position”](#) on [page 83](#)).
2. Remove the needle assembly as follows:
  - a. Unscrew the needle tubing assembly from the needle assembly.
  - b. Pull the latch nut of the needle assembly forward.
  - c. Pull the needle up and out of the needle mount on the XYZ arm.
3. Install a new needle assembly as follows:
  - a. Slide the needle into the needle mount on the XYZ arm.
  - b. Turn the latch to the right.
  - c. Attach the needle tubing assembly to the needle assembly.
4. Home the position of the XYZ arm (see [“Setting the XYZ Arm to the Home Position”](#) on [page 89](#)).

## Changing the Syringe or Replacing the Inner Plunger

You must change the syringe if a different size is required for your application. For the dual-concentric syringe, the lifespan of the inner plunger is approximately 50 000 injections. If the inner plunger of the 250  $\mu$ L syringe wears out—that is, if fluid leaks out of the bottom of the syringe, you must replace the plunger. For the inner plunger part number, see [page 124](#).

To replace the syringe or the syringe plunger, follow these steps:

1. [Setting the Syringe to the Removal Position](#)
2. [Removing the Syringe from the Autosampler](#)
3. [Replacing the Inner Plunger of the Syringe](#)
4. [Installing the Syringe](#)
5. [Setting the Syringe to the Home Position](#)

### Setting the Syringe to the Removal Position

#### ❖ To set the syringe to the removal position

Do the following:

- For the Xcalibur data system, open the Direct Control dialog box for the autosampler (see [“Using the Xcalibur Direct Control Commands”](#) on [page 141](#)). Select **Set Syringe to Removal Position**, and then click **Apply**.
- For the ChromQuest data system, open the Direct Controls page for the autosampler (see [“Using the ChromQuest Direct Commands”](#) on [page 143](#)). Select **Position Syringe for Removal**, and then click **Submit**.

The inner plunger of the dual-concentric syringe and the syringe drive move downward.

### Removing the Syringe from the Autosampler

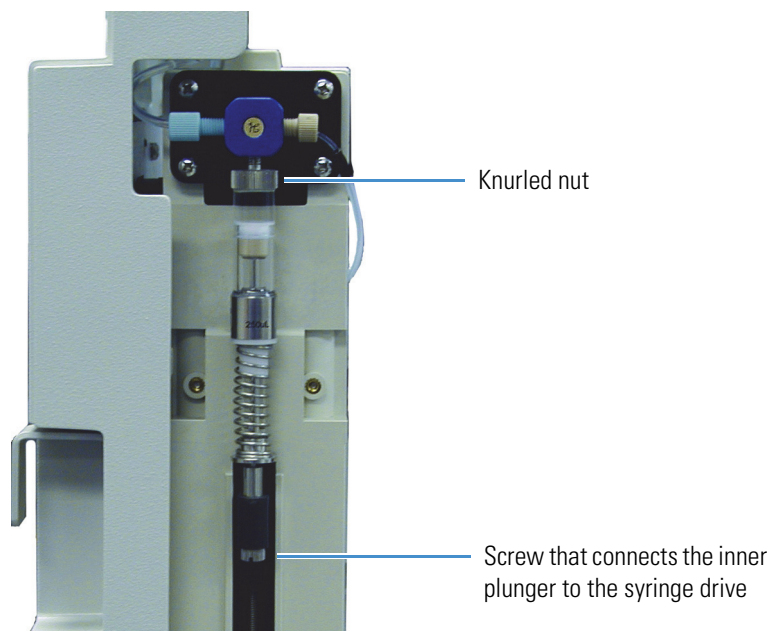
#### ❖ To remove the syringe

1. Set the syringe to the removal position (see the previous procedure, [Setting the Syringe to the Removal Position](#)).
2. Undo the screw that connects the syringe plunger to the syringe drive (see [Figure 69](#)).
3. Loosen and remove the syringe by turning the knurled top of the syringe counterclockwise (see [Figure 69](#)).

## 4 Routine Maintenance

Changing the Syringe or Replacing the Inner Plunger

**Figure 69.** Syringe mounted to the syringe drive assembly

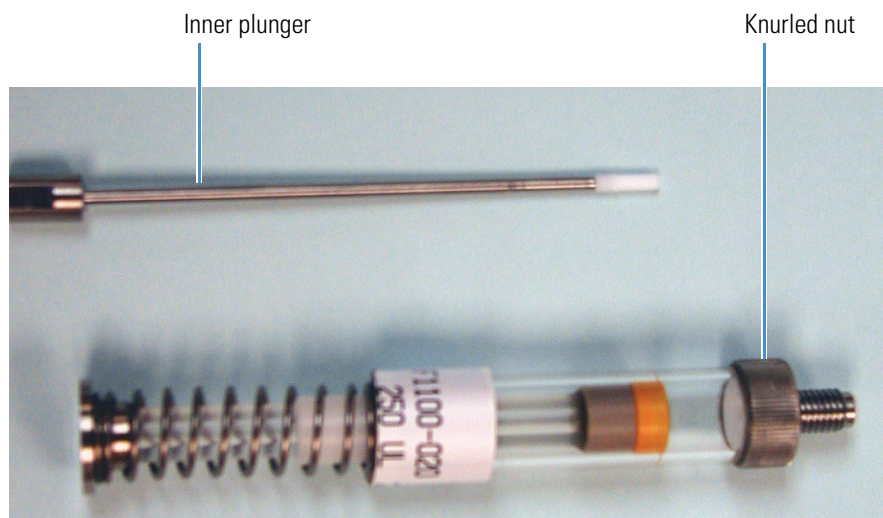


## Replacing the Inner Plunger of the Syringe

### ❖ To replace the inner plunger

1. Remove the syringe from the autosampler (see “To set the syringe to the removal position” on [page 91](#)).
2. Pull the worn plunger out of the bottom of the syringe (see [Figure 70](#)).
3. Replace the worn plunger with a new replacement inner plunger.

**Figure 70.** Inner plunger removed from the dual-concentric syringe



## Installing the Syringe

### ❖ To reinstall the syringe

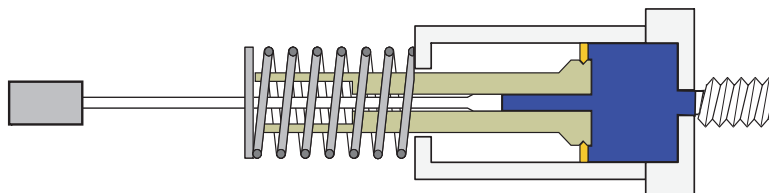
1. Screw the top of the syringe into the syringe valve.
2. Reconnect the bottom of the inner plunger to the syringe drive.
3. Home the position of the syringe plungers (see the next procedure, [Setting the Syringe to the Home Position](#)).

## Setting the Syringe to the Home Position

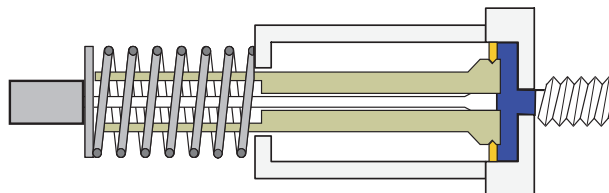
Figure 71 shows the relative positions of the syringe plungers in the syringe removal position and the home position.

**Figure 71.** Relative positions of the syringe plungers

### Removal position



### Home position



### ❖ To set the syringe to the home position

Do the following:

- For the Xcalibur data system, open the Direct Control dialog box for the autosampler (see [“Using the Xcalibur Direct Control Commands”](#) on page 141). Select **Set Syringe to Home Position**, and then click **Apply**.
- For the ChromQuest data system, open the Direct Controls page for the autosampler (see [“Using the ChromQuest Direct Commands”](#) on page 143). Select **Position Syringe to Home**, and then click **Submit**.

The inner plunger moves upward until the nut on the bottom of the plunger meets the washer on the bottom of the syringe. Then both plungers move upward until they are 1.5 mm (0.06 in.) below the top of the outer syringe barrel.

**IMPORTANT** If you change the size of the syringe, you must change the syringe type parameter for the configuration of the Accela Autosampler.

## Clearing a Plugged Heat Exchanger

The current heat exchanger is a piece of 0.004 in. ID × 1/16 in. OD stainless steel tubing located behind the column oven plate (see [Figure 74](#)).

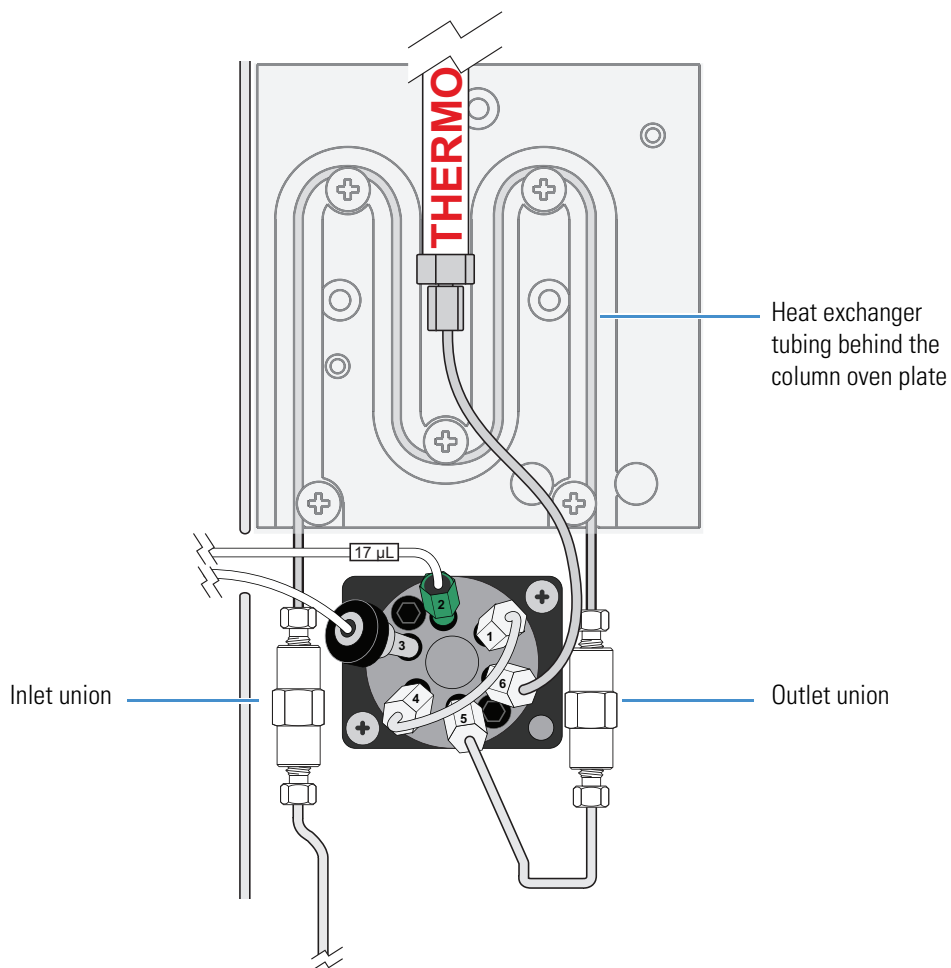
**Note** The original heat exchanger has internal female fittings and does not require unions to connect the solvent lines to the inlet and outlet ports. If your autosampler has the original version of the heat exchanger, see “[Legacy Versions of the Accela Autosampler](#)” on [page 139](#).

To clear a plug from the heat exchanger, backflush the tubing by reversing the solvent flow.

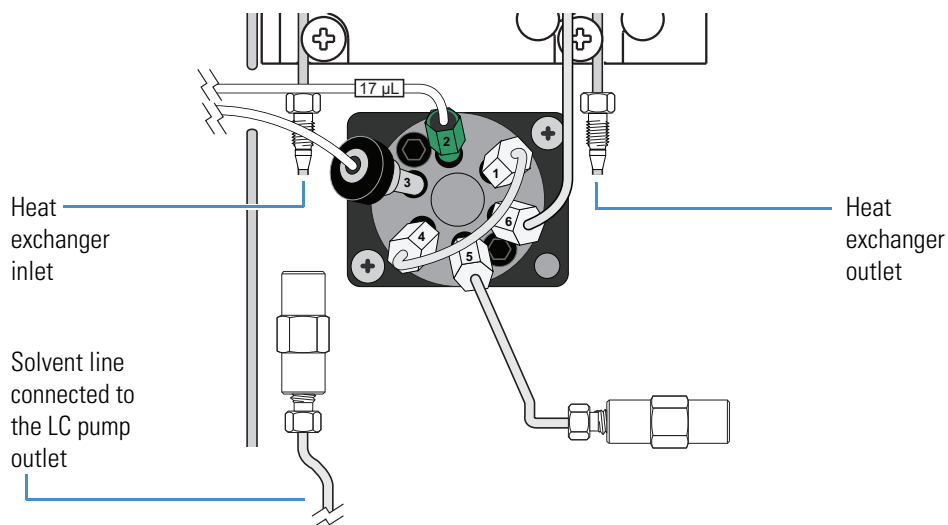
### ❖ To backflush the heat exchanger tubing

1. Using a 1/4 in. open-end wrench, disconnect the union connected to the heat exchanger inlet (see [Figure 72](#)) and disconnect the union connected to the heat exchanger outlet (see [Figure 73](#)).

**Figure 72.** Heat exchanger schematic, showing the unions connected to the inlet and outlet ends of the tubing

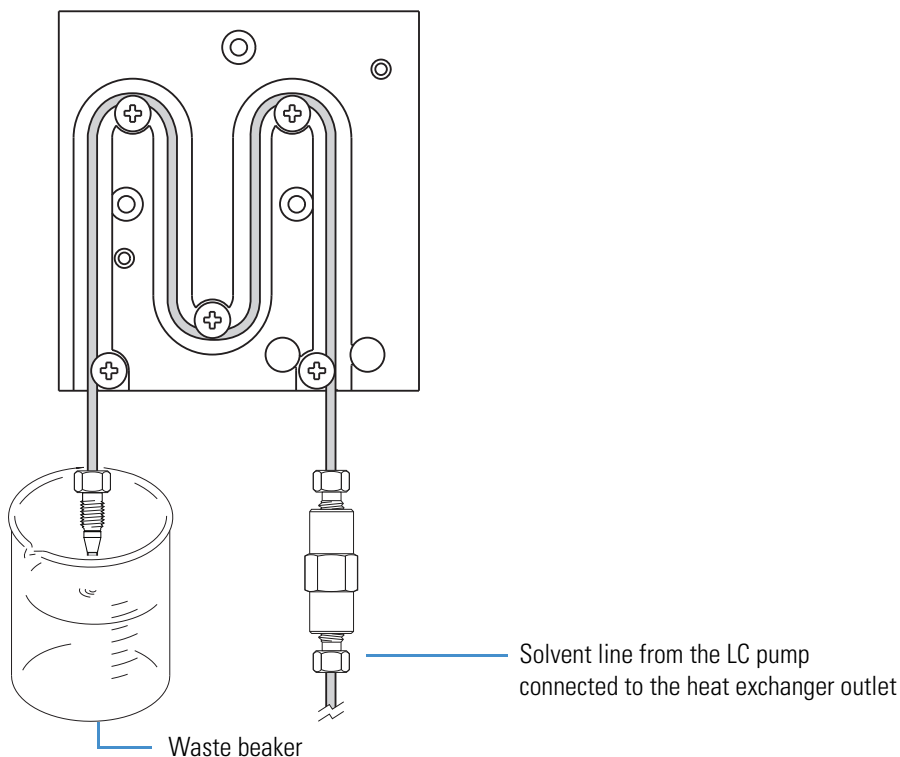


**Figure 73.** Unions disconnected from the inlet and outlet ends of the heat exchanger tubing



2. Connect the solvent flow from the LC pump to the heat exchanger outlet.

**Figure 74.** Heat exchanger schematic, showing the solvent flow reversed

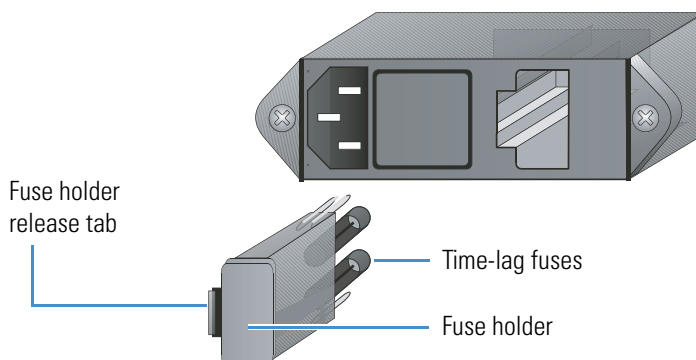


3. Set up a waste beaker to collect the solvent flow from the heat exchanger inlet.
4. Set the flow rate from the LC pump to 1 mL/min.
5. After you clear the plug, reconnect the LC pump to the inlet of the heat exchanger and reconnect the outlet of the heat exchanger to port 5 of the injection valve.

## Replacing a Fuse

Instrument power is supplied by two 5.0 A, 250 V, TL, 5 OD × 20 mm length fuses. The fuses are housed in the fuse compartment on the lower right corner as you are facing the back panel of the autosampler (see Figure 75). If an electrical component in your autosampler stops working, first check for a blown fuse.

**Figure 75.** Power entry module



**CAUTION** Disconnect the power cord before you replace fuses.

### ❖ To replace a fuse

1. Turn off the autosampler and disconnect its power cord.
2. Use a flat blade to press down on the plastic tab at the top edge of the fuse compartment and pull out the fuse holder.
3. Inspect each fuse for a burned or broken wire (which indicates a blown fuse).
4. Pull the blown fuse out of the holder and discard it. Place the new fuse (5.0 A, 250 V, TL, 5 × 20 mm) into the holder with the metal end visible.



**CAUTION** When you are replacing fuses, use only fuses of the type and current rating specified. Do not use repaired fuses and do not short-circuit the fuse holder.

5. Snap the fuse holder back into place.
6. Reconnect the power cord and turn on the autosampler.

If the replacement fuse fails in a short time, you have a serious electrical problem. Leave the blown fuse in place and contact your Thermo Fisher Scientific service representative.

## Maintenance Cycles

The rotor seal, injection needle, and inner syringe plunger wear with use. From the data system, you can set the scheduled maintenance time (SMT) for these autosampler components.

To set the maintenance cycles, follow the procedure for your data system:

- [Setting the Maintenance Cycles from the Xcalibur Data System](#)
- [Setting the Maintenance Cycles from the ChromQuest Data System](#)

### Setting the Maintenance Cycles from the Xcalibur Data System

Each page of the Maintenance Information dialog box contains a Usage Limit box, a Current Counter readback, a Set New Limit button, and a Zero Counter button. Use each page to set a new usage limit, view the current counter readback, or zero the current counter reading.

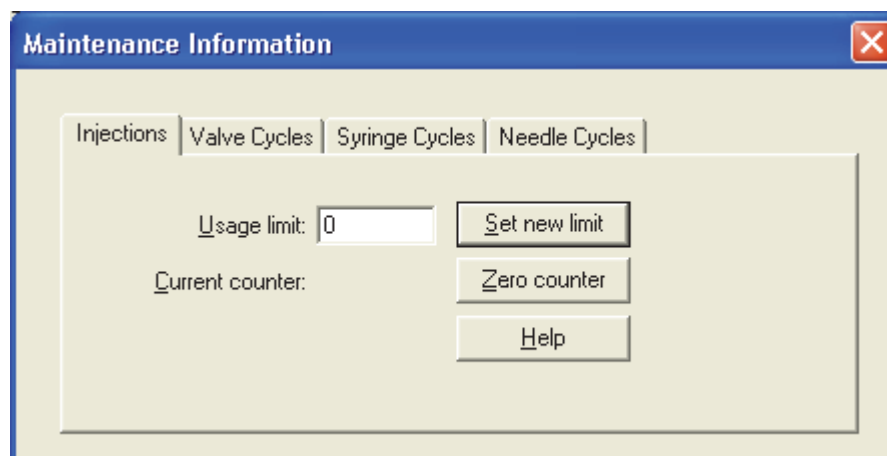
If the counter exceeds the usage limit, the Accela Autosampler cannot start a run until you perform the scheduled maintenance, or you select the Enable Maintenance Log check box of the Accela Autosampler Configuration dialog box.

#### ❖ To set the scheduled maintenance limits from the Xcalibur data system

1. In the Instrument Setup window for the Accela AS, choose **Accela AS > Maintenance**.

The Maintenance Information dialog box appears (see [Figure 76](#)).

**Figure 76.** Maintenance Information dialog box (Xcalibur data system)



2. Depending on the usage limit you want to set, open the appropriate page.

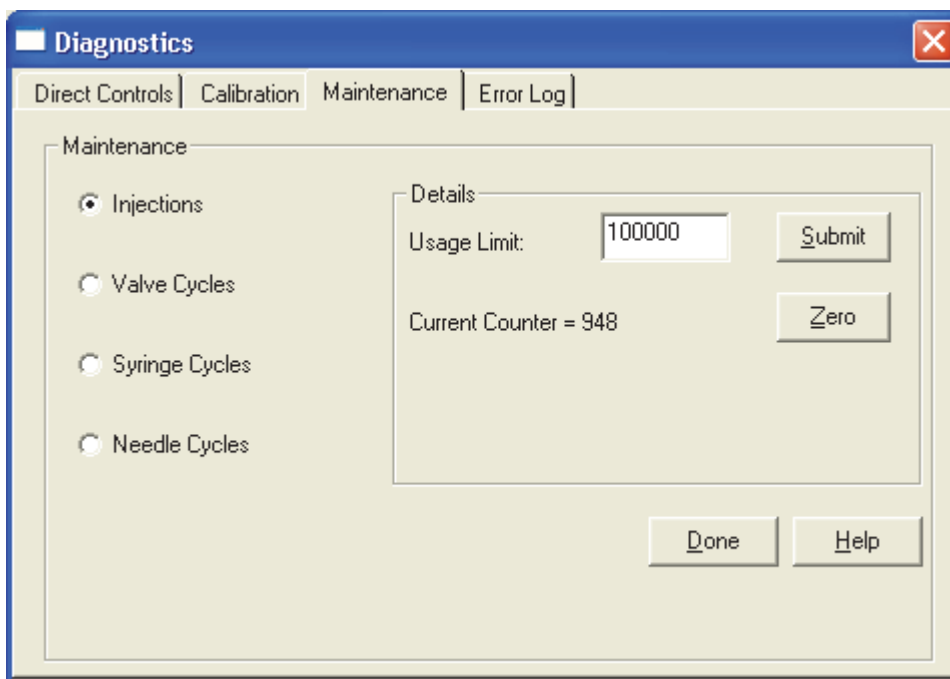
Page	Usage limit
Injections	Maximum number of autosampler injections
Valve Cycles	Maximum number of times that the autosampler can switch the valve between the fill and inject positions
Needle Cycles	Maximum number of times that the autosampler can insert the needle into a vial septum, the injection port, or the wash station
Syringe Cycles	Maximum number of times that the autosampler can return the syringe to the Ready position

3. To change the usage limit, type the new value in the Usage Limit box, and then click **Set New Limit**.
4. To zero the counter, click **Zero Counter**.

## Setting the Maintenance Cycles from the ChromQuest Data System

The Maintenance page in the ChromQuest data system contains four options: Injections, Valve Cycles, Syringe Cycles, and Needle Cycles. After you select an option, its corresponding Details box appears on the right side of the Maintenance page. You can use each Details box to set a usage limit, view the current counter readback, or zero the current counter reading (see [Figure 77](#)).

**Figure 77.** Maintenance page (ChromQuest data system)



If the counter exceeds the usage limit, the Accela Autosampler cannot start a run until you perform the scheduled maintenance or you clear the Enable Maintenance Log check box of the Accela Autosampler Configuration dialog box.

❖ **To set up the maintenance cycles from the ChromQuest data system**

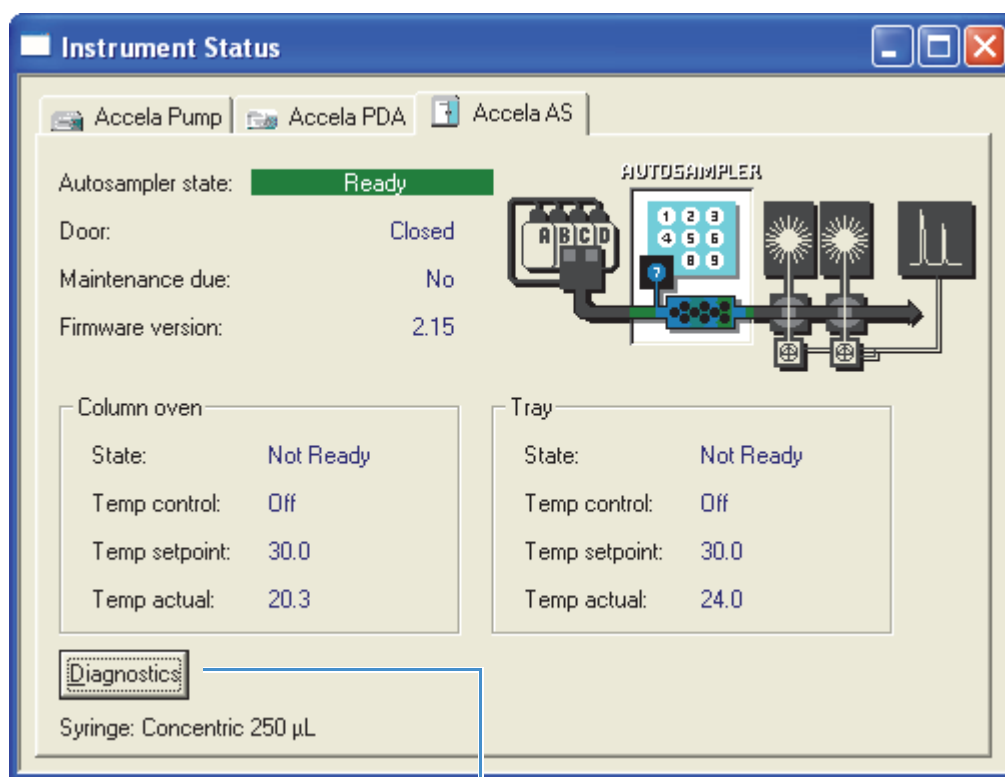
1. In the online Instrument window, choose **Control > Instrument Status**.

The Instrument Status window appears.

2. Click the **Accela AS** tab.

The Accela AS status page appears (see [Figure 78](#)).

**Figure 78.** Accela AS status page (ChromQuest data system)



Diagnostics button

3. Click **Diagnostics**.

The Diagnostics dialog box appears.

4. Click the **Maintenance** tab.

The Maintenance page appears (see [Figure 77](#) on [page 98](#)).

5. Select the option that you want to set:
  - To set the usage limit for the number of user-defined injections, select the **Injections** option.
  - To set the usage limit for the number of user-defined valve cycles (from Fill to Inject), select the **Valve Cycles** option.
  - To set the usage limit for the number of user-defined syringe cycles where the syringe is put in the Ready position, select the **Syringe Cycles** option.
  - To set the usage limit for the number of user-defined needle cycles where the needle is inserted into a septum, injection port, or wash station, select the **Needle Cycles** option.
6. To change the usage limit, type the new value in the Usage Limit box, and then click **Submit**.

## Diagnostics

Use the Accela Autosampler diagnostics to test the major electronic circuits within the instrument and to indicate whether the circuits pass or fail the tests. If the instrument electronics fail, the diagnostics can often locate the problem. However, to distinguish a hardware failure from an electronic failure, someone who is familiar with system operation and basic hardware theory must run the diagnostics.

You can use the diagnostics to test many of the Accela Autosampler components. The Thermo Fisher Scientific service philosophy is to troubleshoot the problem to the lowest part, assembly, PCB, or module listed in [Appendix A, “Consumables and Service Parts.”](#) You can replace the parts listed in [“Consumables” on page 124](#), and a Thermo Fisher Scientific field service engineer can replace the parts listed in [“Service Parts” on page 125](#).

### Contents

- [Power Up Diagnostics](#)
- [Error Log in the Xcalibur Data System](#)
- [Error Log in the ChromQuest Data System](#)
- [Autosampler Validation Information](#)

## Power Up Diagnostics

Accela Autosampler power up diagnostics run automatically when you turn on the autosampler and take about 2 minutes to run. Most of the time required for the power up diagnostics is occupied testing the RAM.

If there is a memory error of a fatal type, the right three lights of the Status LEDs turn amber. If this happens, contact Thermo Fisher Scientific Technical Support. The CPU PCB probably needs to be replaced.

If diagnostics detect any other type of error, the Run Status LED illuminates amber and the autosampler records the error in its persistent memory log. You can access this error log through the data system.

Table 13 lists the startup diagnostics error messages. The left column lists the error messages that your Thermo Scientific field service engineer can view from HyperTerminal™ (or equivalent application). The right column lists the error messages that might appear in the autosampler error log.

When the startup test passes, the error log displays this message: No error. No other events occur.

**Table 13.** Autosampler startup error messages (Sheet 1 of 2)

HyperTerminal error messages	Error log messages
EC_SDIAGS_BAD_Z_FLAG	The <i>z</i> -axis home flag failed.
EC_SDIAGS_BAD_S_FLAG	The <i>s</i> -axis home flag failed.
EC_SDIAGS_BAD_X_FLAG_INT	The <i>x</i> -axis interrupt failed.
EC_SDIAGS_BAD_Y_FLAG_INT	The <i>y</i> -axis interrupt failed.
EC_SDIAGS_BAD_Z_FLAG_INT	The <i>z</i> -axis interrupt failed.
EC_SDIAGS_BAD_S_FLAG_INT	The <i>s</i> -axis interrupt failed.
EC_SDIAGS_BAD_1_MOTION_TIMER	Motion Timer A failed.
EC_SDIAGS_BAD_2_MOTION_TIMER	Motion Timer B failed.
EC_SDIAGS_BAD_3_MOTION_TIMER	Motion Timer C failed.
EC_SDIAGS_BAD_4_MOTION_TIMER	Motion Timer D failed.
EC_SDIAGS_BAD_Z_BOTTOM_FLAG	The <i>z</i> -bottom flag failed.
EC_SDIAGS_TIMER_SETUP_ERROR	Occurs if an error status is returned by the disable interrupt call.
EC_SDIAGS_NO_INJ_CABLE	The injector motor cable is not connected.
EC_SDIAGS_BAD_INJ_POS	The injection valve did not change position.
EC_SDIAGS_BAD_SYRINGE_VALVE_INT	The syringe valve interrupt did not occur.
EC_SDIAGS_BAD_FLUSH_VALVE_INT	The flush valve interrupt did not occur.
EC_SDIAGS_BAD_CAPACITOR	The capacitor did not charge to the acceptable level.
EC_SDIAGS_X_MOTOR_NOT_PRESENT	The <i>x</i> -axis motor was not detected.
EC_SDIAGS_Y_MOTOR_NOT_PRESENT	The <i>y</i> -axis motor was not detected.
EC_SDIAGS_Z_MOTOR_NOT_PRESENT	The <i>z</i> -axis motor was not detected.
EC_SDIAGS_S_MOTOR_NOT_PRESENT	The <i>s</i> -axis motor was not detected.
EC_SDIAGS_XZ_CONNECTOR_NOT_CONNECTED	The cable that connects the <i>x</i> - and <i>z</i> -axis motors is not connected.
EC_SDIAGS_BAD_REG_VALUE	One of the memory registers is not set correctly.


**Table 13.** Autosampler startup error messages (Sheet 2 of 2)

<b>HyperTerminal error messages</b>	<b>Error log messages</b>
EC_SDIAGS_MOTOR_ERROR	The motor diagnostic bits did not change to the correct state.
EC_SDIAGS_ISR_TIMEOUT	The interrupt did not occur before the interrupt timeout did.
EC_SDIAGS_METAL_OUTOF_RANGE	The oven or tray metal readings were not within the specified low and high.
EC_SDIAGS_OVEN_AIR_OUTOF_RANGE	The oven air readings were not within the specified low and high.
EC_SDIAGS_24V_OUTOF_RANGE	The oven or tray 24 V readings were not within the specified low and high.
EC_SDIAGS_12V_OUTOF_RANGE	The oven or tray 12 V readings were not within the specified low and high.
EC_SDIAGS_OVEN_MIRROR_OUTOF_RANGE	The readings for the oven mirror were not within the specified low and high.
EC_SDIAGS_UNKNOWN_DEVICE	A call was made to the temperature diagnostics with an unknown device.
EC_SDIAGS_VIAL_MIRROR_OUTOF_RANGE	The readings for the tray mirror were not within the specified low and high.
EC_SDIAGS_HOME_ERROR	A move to the home flag did not set the home flag bit correctly.

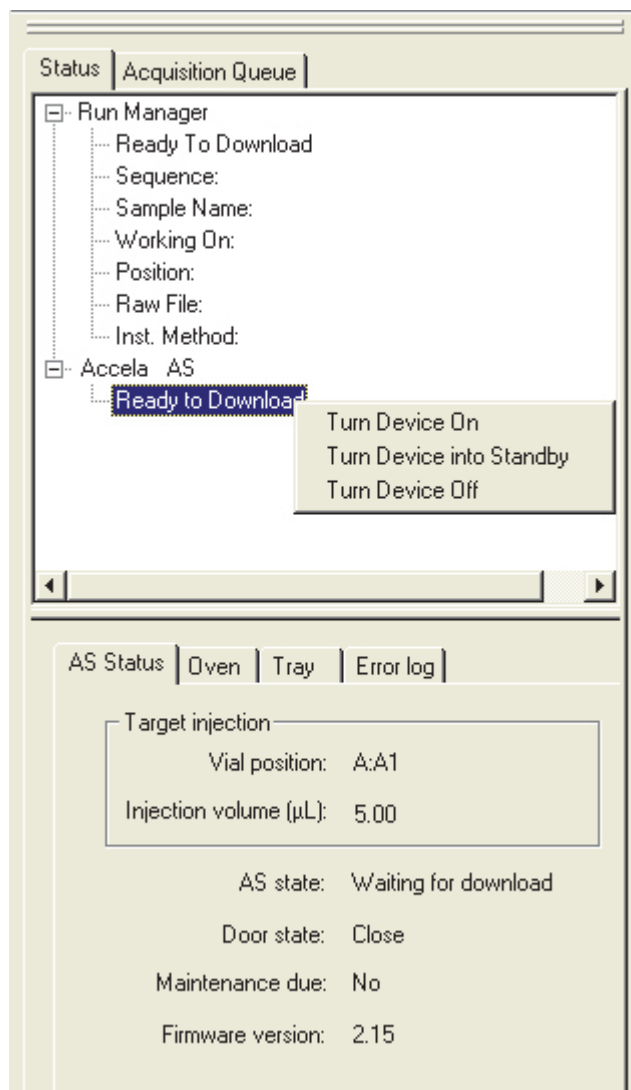
## Error Log in the Xcalibur Data System

The error log in the Xcalibur data system lists the diagnostic error messages. You can access the error log through the status page of the Information View. The Information View is normally displayed on the left side of the Home Page window and contains two pages: Status and Acquisition Queue. If the Home Page window does not display this view, it has been turned off.

### ❖ To open the Information View

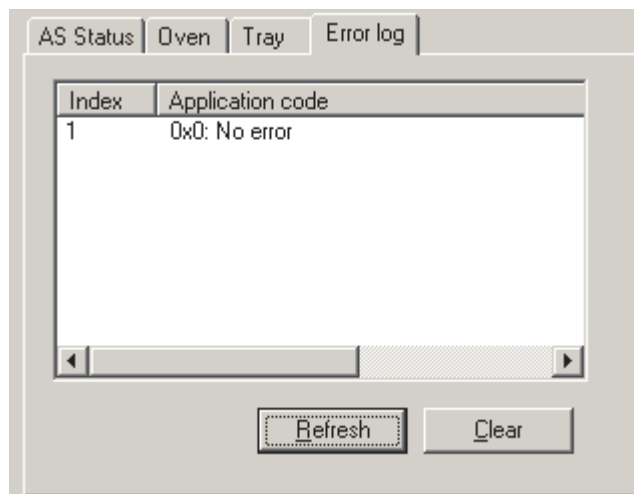
From the Home Page window, choose **View > Info View** or in the tool bar, click  to turn the Information View on and off. See [Figure 79](#).

**Figure 79.** Status page of the Information View with the Accela AS selected in the directory tree



**❖ To access the error log for the Accela Autosampler**

1. Click the **Accela AS directory** in the Status window to activate its status pages.
2. Click the **Error Log** tab to open the Error Log page (see [Figure 80](#)).

**Figure 80.** Error log for the Accela Autosampler

3. Click **Refresh** to display the list of errors.
4. After reviewing the error list, click **Clear** to erase the list.

## Error Log in the ChromQuest Data System

The error log in the ChromQuest data system lists the diagnostic error messages.

**❖ To open the error log**

1. From the Instrument window, choose **Control > Instrument Status** to display the Instrument Status window.
2. Click the **Accela AS** tab to display the Accela AS page of the Instrument Status window.
3. Click **Diagnostics** to display the Diagnostics dialog box.
4. Click the **Error Log** tab to display the error log for the Accela Autosampler.
  - To view the error log, click **Refresh**.
  - To clear the error log, click **Clear**.

## Autosampler Validation Information

The Xcalibur data system keeps track of validation information. Use the Validation Information dialog box to enter the date when the validation occurred and the name of the person who performed the validation.

### ❖ To open the Validation Information dialog box

From the Instrument Setup window, choose **Accela AS > Validation**.

The Validation Information dialog box has the following pages:

- Sample Tray Low Temp
- Sample Tray High Temp
- Column Oven Low Temp
- Column Oven High Temp
- Inject Reproducibility
- Dilution Reproducibility

Use these pages to enter the calendar dates when the validation occurred and the initials of the person who performed the validation (see [Figure 81](#)).

**Figure 81.** Validation Information dialog box

The screenshot shows the 'Validation Information' dialog box. It features a title bar with a close button. The main area contains a grid of six tabs: 'Sample Tray Low Temp', 'Sample Tray High Temp', 'Inject Reproducibility', 'Dilution Reproducibility', 'Column Oven Low Temp' (which is selected and highlighted with a dotted border), and 'Column Oven High Temp'. Below the tabs, there are two columns: 'Set values' and 'Current values'. Under 'Set values', there is a 'Time:' label followed by a date field containing '03/11/2005' and an 'Initial name:' label followed by an empty text box. Under 'Current values', the text 'Invalid' is displayed. At the bottom, there are two buttons: 'Set' and 'Help'.

## Routine Troubleshooting

This chapter provides information to help you troubleshoot possible autosampler problems.

When troubleshooting, consider the following:

- Did the system fail when you were running samples?
- Did problems occur after you performed maintenance on the instrument?
- Did you change the system configuration, cables, or peripherals just before the problem occurred?

If the answer is yes to the first question above, the issue might be a hardware failure.

If the answer is yes to one of the latter two questions above, the issue is probably mechanical, not electrical. Verify that alignment, configurations, and cable connections are correct.

If, after reviewing the troubleshooting table included in this chapter, you would like additional assistance in troubleshooting a particular problem, contact Thermo Fisher Scientific Technical Support or your service representative.

### Contents

- [General Chromatography Troubleshooting](#)
- [Autosampler-Specific Troubleshooting](#)
- [Common Operator Errors](#)
- [Determining the Transfer Tubing Volume](#)

## General Chromatography Troubleshooting

Table 14 lists general chromatographic problems. For more information about chromatographic troubleshooting, refer to any HPLC troubleshooting reference book, or contact technical support or your service representative.

**Table 14.** General chromatography troubleshooting table (Sheet 1 of 2)

Symptom	Remedy
No flow	<ul style="list-style-type: none"> <li>• Check the mobile phase connections.</li> <li>• Check for leaks.</li> <li>• Refer to the hardware manual for your pump.</li> </ul>
High backpressure	<ul style="list-style-type: none"> <li>• Check the flow rate and system/column specifications.</li> <li>• Check for tubing or column blockage.</li> <li>• Refer to the hardware manual for your pump.</li> </ul>
Unstable baseline or drift	<ul style="list-style-type: none"> <li>• System/column not equilibrated; allow more time.</li> <li>• Refer to the detector troubleshooting guide.</li> </ul>
Baseline noise	<ul style="list-style-type: none"> <li>• Check for air bubbles in system, degas solvents.</li> <li>• Check for system/solvent contamination.</li> <li>• Check the hardware manual for your pump.</li> </ul>
No peaks	<ul style="list-style-type: none"> <li>• Check the detector and data system computer connections.</li> <li>• See “<a href="#">Autosampler-Specific Troubleshooting.</a>”</li> <li>• Check sample retention with chromatographic conditions.</li> </ul>
Contamination/ghost peaks	<ul style="list-style-type: none"> <li>• Clean the system and column.</li> <li>• See “<a href="#">Autosampler-Specific Troubleshooting.</a>”</li> <li>• Refer to the hardware manual for your pump.</li> </ul>
Poor peak shape	<ul style="list-style-type: none"> <li>• Check the system for leaks.</li> <li>• Check fittings and tubing lengths.</li> <li>• Check column performance.</li> <li>• See “<a href="#">Autosampler-Specific Troubleshooting.</a>”</li> <li>• Refer to the hardware manual for your pump.</li> <li>• Refer to the hardware manual for your detector.</li> </ul>
Poor retention time reproducibility	<ul style="list-style-type: none"> <li>• Check the system for leaks and bubbles.</li> <li>• System/column not equilibrated; allow more time.</li> <li>• Check column performance.</li> <li>• Check the hardware manual for your pump.</li> <li>• See “<a href="#">Autosampler-Specific Troubleshooting.</a>”</li> </ul>
Poor peak area reproducibility	<ul style="list-style-type: none"> <li>• Check column performance.</li> <li>• See “<a href="#">Autosampler-Specific Troubleshooting.</a>”</li> </ul>

**Table 14.** General chromatography troubleshooting table (Sheet 2 of 2)

Symptom	Remedy
Non-integrated peaks or too many peaks	<ul style="list-style-type: none"> <li>Refer to the hardware manual for each of the modules in your LC system.</li> <li>Refer to the data system manual for information on setting peak identification and integration.</li> </ul>
No instrument or device control	<ul style="list-style-type: none"> <li>Check the cable connections.</li> <li>Check the system configuration.</li> <li>Refer to the hardware manuals for each of the modules in your LC system.</li> </ul>

## Autosampler-Specific Troubleshooting

This section focuses on problems that might occur with the autosampler portion of your HPLC system. It contains the following topics:

- [Chromatography Problems](#)
- [Hardware Problems](#)

### Chromatography Problems

[Table 15](#) lists potential chromatography problems associated with the autosampler.

**Table 15.** Chromatography problems (Sheet 1 of 4)

Symptom	Possible problem	Remedy
1. Baseline drift when the injection valve changes from inject to fill	a. Lack of thermal stability in the column oven compartment, detector, or mobile phase	a. Eliminate drafts around the column compartment. Wait until the column oven has reached thermal equilibrium. If the problem persists, contact your Thermo Fisher Scientific service representative.
2. Shifting retention times	a. Temperature variations in the lab b. Column heater problems	a. Stabilize the temperature. b. Contact your Thermo Fisher Scientific service representative.

**Table 15.** Chromatography problems (Sheet 2 of 4)

Symptom	Possible problem	Remedy
3. Sensitivity changes	a. Inconsistent sample injection volumes	a. Check for a partially blocked injection valve and observe the pressure. If the problem persists, see <a href="#">“Replacing the Rotor Seal in the Valco Injection Valve”</a> on page 61.
	b. Leaks between the injection valve and the column causing inconsistent sample volume injection	b. Tighten or change the fitting.
	c. Air bubbles aspirated into the lines along with sample	c. Replenish/prepare fresh sample and repeat the injection.  Decrease the syringe speed.
	d. Incomplete sample mixing during sample preparation	d. Thaw frozen samples completely before sample preparation to prevent sample "layering."
	e. Sample adsorption to the walls of the injection valve or sample loop	e. Change the mobile phase composition.
	f. Sample solvent incompatible with the mobile phase	f. Change the solvent. Use a different mobile phase if possible.
	g. Sample insoluble in solvent	g. Be sure the sample solvent has a lower elution strength than the mobile phase.
	h. Air in syringe/sample lines	h. Flush sample lines.
4. Irregular peak shapes	a. The volume of sample injected exceeds the column's capacity.	a. Decrease the volume injected or dilute the sample.
	b. The strength of the solvent used to dilute the sample exceeds the initial concentration of the mobile phase.	b. If appropriate for your application, ensure that the flush solvent is of the same composition as the solvent used to dissolve the sample and that its organic content never exceeds the initial composition of the mobile phase.
	c. Degradation of sample components	c. Prepare fresh sample and repeat the injection.

**Table 15.** Chromatography problems (Sheet 3 of 4)

Symptom	Possible problem	Remedy
5. Band broadening	a. Fitting problem at the injection valve-column connection	a. Inspect for damage, mismatch, or incorrect assembly.
	b. Tubing ID too large	b. Use 0.010 in. ID tubing from the injection valve to the column and from the column to the detector.
6. Smaller than expected peak heights	a. Small injection due to incorrect size syringe in configuration	a. Check the syringe size in the autosampler device driver configuration.
	b. Incorrect injection volume for the injection mode	b. Check the injection volume value in the file. For partial loop injections, limit the maximum injection volume to half the sample loop size. For no waste injections, limit the maximum injection volume to 5 µL less than the sample loop size.
	c. Incorrect value for the transfer tubing	c. Check the dead volume value in the configuration. The dead volume for the transfer tubing is specified on its attached label. See <a href="#">Figure 10</a> on <a href="#">page 11</a> .
	d. Air in lines	d. Perform a Needle Wash direct command to remove air from the wash bottle tubing and the syringe.
	e. Incorrectly adjusted syringe drive mechanism	e. Contact your Thermo Fisher Scientific service representative.
7. Peaks during a blank injection (from a previous injection)	a. Sample carryover due to residual sample in the sample loop	a. Increase flush volume. Increase injection volume, add a blank vial between sample vials, or use a stronger flush solvent.
	b. Sample carryover due to incorrectly assembled sample loop fittings (adding dead volume that can contain residual sample)	b. Check and redo connections.
	c. Sample carryover due to a contaminated needle guide	c. Clean the needle guide.
	d. Sample too concentrated	d. Dilute the sample.

**Table 15.** Chromatography problems (Sheet 4 of 4)

Symptom	Possible problem	Remedy
8. No peaks	a. Empty wash bottle or excessive air in the wash tubing	a. Fill the wash bottle with solvent. Remove air from the wash tubing and the syringe.
	b. Plugged or bent needle	b. Clean or replace the needle. Tighten the fittings and the syringe.
	c. Leaking syringe valve fitting at the wash tubing connection	c. Tighten the fitting.
	d. Plugged or leaking tubing	d. Replace faulty tubing.
9. Lack of precision, accuracy, or both on a sample of known content-random error	a. Air leak	a. Tighten all fittings and repeat the run.
	b. Worn out syringe	b. Replace the syringe (see <a href="#">“Changing the Syringe or Replacing the Inner Plunger”</a> on page 91).
	c. Worn out rotor (Valco injection valve)	c. Replace the rotor (see <a href="#">“Replacing the Rotor Seal in the Valco Injection Valve”</a> on page 61).
	d. Worn out rotor seal (Rheodyne injection valve)	d. Replace the rotor seal (see <a href="#">“Replacing the Rotor Seal in the Rheodyne Valve”</a> on page 135).
10. Irreproducibility of peak areas	a. Plugged or bent needle	a. Clean/replace needle (see <a href="#">“Replacing the Needle Assembly”</a> on page 90). Tighten fittings and syringe.
	b. Leaking flush valve fitting	b. Tighten fitting.
	c. Plugged or leaking tubing	c. Replace faulty tubing.
	d. Sample viscosity too low or too high	d. Change viscosity setting.
	e. Wash solvent viscosity too low or too high	e. Change wash solvent or flush speed.

## Hardware Problems

Table 16 lists the potential hardware problems associated with the autosampler.

**Table 16.** Hardware problems associated with the Accela Autosampler (Sheet 1 of 4)

Symptom	Possible problem	Remedy
<b>Startup</b>		
1. Nothing works when instrument is turned on.	a. Power cord unplugged or faulty	a. Plug in or replace the power cord.
	b. Blown fuse	b. Replace the fuse (see “ <a href="#">Replacing a Fuse</a> ” on page 96).
	c. Defective power switch, driver, transformer	c. Contact your Thermo Fisher Scientific service representative.
<b>Communications</b>		
2. No Ethernet communication	a. Incorrect computer NIC settings	a. Check the address. Use only TCP/IP protocol.
	b. Ethernet hardware problem	b. Check the Ethernet switch and Ethernet cables.
3. External devices are not triggered.	a. Incorrect timed event settings in the acquisition method	a. Check the timed event settings in the acquisition method.
	b. Interface equipment problem	b. See “ <a href="#">Connecting the System Interconnect Cable</a> ” on page 37 or refer to the <i>Accela Getting Connected Guide</i> for information on contact closure connections.
<b>Vials</b>		
4. Instrument cannot locate vial.	a. Incorrect vial position entered into sample sequence	a. Check the sample sequence.
	b. Sample incorrectly placed in sample tray	b. Check the tray arrangement.
	c. XYZ arm misaligned	c. Recalibrate the XYZ arm. Refer to the data system Help.
	d. XYZ arm movement restricted	d. Remove restriction and home arm. See “ <a href="#">Important Precautions for Sample Loading</a> ” on page 54.
	e. Loose left-hand guide bracket	e. Ensure that the bracket is tightly attached and level.
5. Vials do not fit in tray.	a. Incorrect vials	a. Check that the vial diameter is 11 to 12 mm (0.43 to 0.47 in.).

**Table 16.** Hardware problems associated with the Accela Autosampler (Sheet 2 of 4)

Symptom	Possible problem	Remedy
6. Torn septum	a. Bent needle	a. Replace the needle (see “ <a href="#">Replacing the Needle Tubing Assembly</a> ” on page 83).
7. Septum pushed into vial	a. Incorrect vial caps	a. Use only recommended vials and vial caps. See “ <a href="#">Recommended Vials, Microplates, and Microplate Covers</a> ” on page 55.
	b. Loose vial caps	b. Ensure that the vial caps are fully tightened.
<b>Injection valve</b>		
8. Injection valve will not switch.	a. Slipping injector drive	a. Contact your Thermo Fisher Scientific service representative.
9. Injection valve continues to rotate until fault is generated.	a. Loose or faulty sensor cable	a. Contact your Thermo Fisher Scientific service representative.
10. Injection valve does not rotate to the proper position.	a. Valve requires excessive torque.	a. Contact your Thermo Fisher Scientific service representative.
11. Motor fails to stop after syringe is fully returned.	a. Possible defective sensor	a. Contact your Thermo Fisher Scientific service representative.
12. Sample loop will not fill.	a. Blocked injection valve	a. Follow “ <a href="#">Troubleshooting a Blockage in the Injection System</a> ” on page 77 to isolate blockage. DO NOT clean valve with a cleaning wire or you could damage the valve.
13. Valve seal wears rapidly.	a. Too much valve seal pressure against valve	a. Decrease LC system pressure.
	b. Particulate matter in valve	b. Use an inline filter before the injection valve.
	c. Inadequately filtered sample	c. Filter with a 0.5 m filter before injection.
	d. Buffer crystallization	d. Do not allow buffers to stand in the system. Run a flush sequence when the system is not in use.

**Table 16.** Hardware problems associated with the Accela Autosampler (Sheet 3 of 4)

Symptom	Possible problem	Remedy
<b>Needle</b>		
14. Needle bent or broken	a. Incorrect vials	a. See the list of recommended replacement parts in <a href="#">Appendix A, “Consumables and Service Parts.”</a>
	b. Alignment problem	b. Contact your Thermo Fisher Scientific service representative.
	c. Arm sticking	c. Contact your Thermo Fisher Scientific service representative.
15. Needle plugging	a. Multiple/incorrect septum	a. Verify a single septum of the type recommended (see <a href="#">“Recommended Vials, Microplates, and Microplate Covers”</a> on page 55).
	b. Worn needle	b. Replace the needle (see <a href="#">“Replacing the Needle Assembly”</a> on page 90).
<b>Needle Tubing</b>		
16. Blockage in the needle tubing	a. Crimped needle tubing	a. Replace the needle tubing (see <a href="#">“Replacing the Needle Tubing Assembly”</a> on page 83).
<b>Syringe</b>		
17. Loud buzzing from syringe drive	a. Plugged lines or needle	a. Clear lines or needle (see <a href="#">“Troubleshooting a Blockage in the Injection System”</a> on page 77).
	b. Defective limit switch	b. Contact your Thermo Fisher Scientific service representative.
<b>Transfer tube</b>		
18. Lack of injection precision and accuracy, lack of precision or blank injections	a. Constricted or plugged transfer tube	a. Replace the damaged transfer tube. Avoid overtightening the fitting to port 2 of the injection valve (see <a href="#">“Replacing the Transfer Tubing”</a> on page 69).
<b>Leaks</b>		
19. Leakage during loop filling	a. Blocked loop or waste line, or valve not deflected far enough	a. Flush or replace the sample loop; check and flush the waste line.

**Table 16.** Hardware problems associated with the Accela Autosampler (Sheet 4 of 4)

Symptom	Possible problem	Remedy
20. Cross-port leakage	a. Worn rotor seal (Rheodyne injection valve) or rotor (Valco injection valve)	a. Replace the rotor seal (see “Replacing the Rotor Seal in the Rheodyne Valve” on page 135). Replace the rotor (see “Replacing the Rotor Seal in the Valco Injection Valve” on page 61).
21. Liquid on vial caps	a. Leaky syringe valve	a. Replace the syringe valve.
	b. Leaky injection valve	b. Replace the rotor seal (see “Replacing the Rotor Seal in the Rheodyne Valve” on page 135). Replace the rotor (see “Replacing the Rotor Seal in the Valco Injection Valve” on page 61).
<b>Other</b>		
22. Contaminated sample	a. Dirty vials	a. Replace vials.
	b. Improper septum made of silicone or other rubber-like material	b. Use the recommended septum (see “Recommended Vials, Microplates, and Microplate Covers” on page 55).
23. Elevated system pressures	a. Block between column and autosampler	a. Check for blockage and tubing restrictions.

## Common Operator Errors

Operator errors can compromise the performance of the Accela Autosampler.

These are the most common operator errors:

- Letting the wash bottle run dry
- Routing the needle tubing incorrectly
- Selecting an incorrect syringe type in the Accela Configuration Autosampler dialog box
- Requesting an inappropriate injection volume for the sample loop size and the injection mode
- Entering an incorrect dead volume for the transfer tubing
- Overtightening the transfer tube fitting to port 2 or the waste tube fitting to port 3 of the autosampler injection valve

### Insufficient Wash Solvent

Allowing the wash bottle to run dry disrupts the ability of the syringe to draw liquid into the needle tubing, which consequently results in blank injections. Fill the wash bottle with solvent, and remove air from the wash line tubing before running a sequence of injections.

### Damaged Needle Tubing

Because the needle tubing is easily damaged, routing the needle tubing correctly is critical to the performance of the Accela Autosampler. Take care to avoid kinking the tubing as you route it through the bracket on the XYZ arm.

### Incorrect Syringe Type

Because the autosampler cannot detect the syringe type connected to the syringe drive assembly, confirm that the syringe type in the Accela Configuration Autosampler dialog box matches the autosampler syringe.

The injection volume algorithm used by the autosampler depends on the syringe type that you select when you configure the data system. The distance that the inner syringe plunger must descend to draw the specified injection volume increases as the syringe size decreases. For example, to draw 10  $\mu\text{L}$  of sample, the inner plunger of a 100  $\mu\text{L}$  syringe must descend farther than the inner plunger of a 250  $\mu\text{L}$  syringe. If you replace the 250  $\mu\text{L}$  syringe with a 100  $\mu\text{L}$  syringe, but neglect to modify the data system configuration, the autosampler injects a smaller than expected injection volume because the syringe plunger does not descend far enough to draw the requested injection volume.

## Inappropriate Injection Volume

For best results, follow these rules:

- For no waste injections, limit the maximum injection volume to 5  $\mu\text{L}$  less than the sample loop volume. Limit the minimum injection volume to 1  $\mu\text{L}$  of sample.
- For partial loop injections, limit the maximum injection volume to 40 percent of the nominal sample loop volume.

## Incorrect Dead Volume

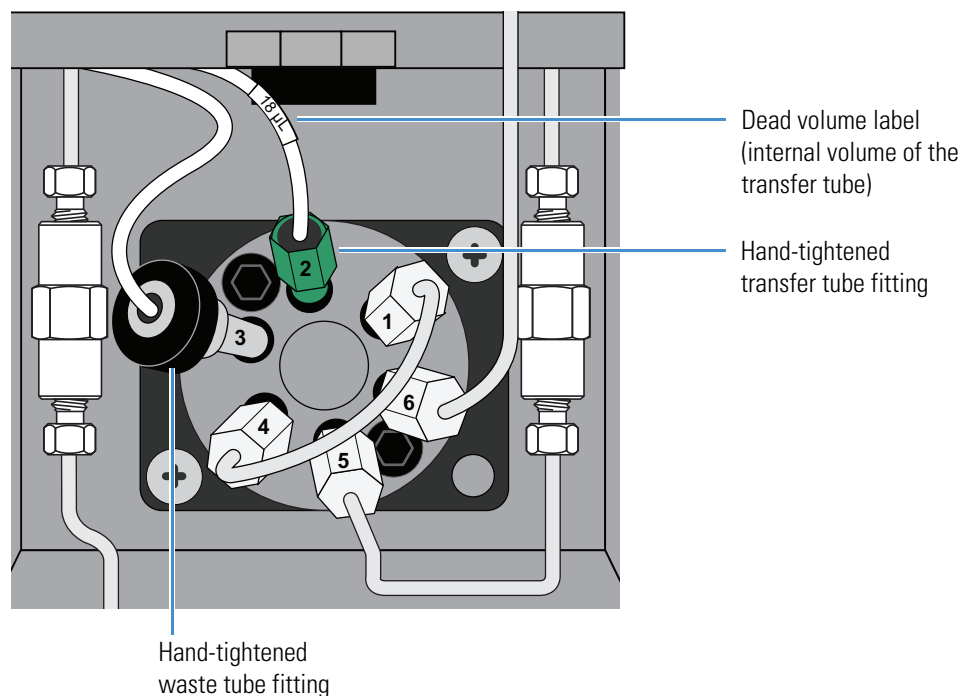
The dead volume of the 0.012 in. ID transfer tubing is specified on the label attached to the tubing. Entering an incorrect dead volume when you specify the configuration options for the autosampler can result in lower than expected peak areas or blank injections.

## Overtightened Transfer Tube or Waste Tube Fittings

Avoid overtightening the low-pressure fittings to the injection valve (see [Figure 82](#)):

- Overtightening the transfer tube fitting constricts the transfer tube, causing a lack of injection precision. Eventually, the constricted transfer tube becomes plugged.
- Overtightening the waste tube fitting constricts the waste tube, increasing the backpressure in the injection system.

**Figure 82.** Transfer tubing connection to port 2 of the injection valve



## Determining the Transfer Tubing Volume

The Dead volume configuration parameter is critical for the no waste injection mode. Specifying an incorrect dead volume value can result in lower than expected peak areas or blank injections. For best results, the specified dead volume must equal the actual volume of the transfer tubing that connects the autosampler injection port to port 2 of the injection valve.

### ❖ To determine the volume of the transfer tubing

1. From the Xcalibur or ChromQuest data system, set up an acquisition method for an analyte that you know the chromatographic conditions for.

Use chromatographic conditions that result in a relatively short retention time for the analyte (to minimize the run time). In the method, select the **No Waste Injection** option.

You can also use the autosampler test mix (0.5 percent toluene in methanol) that comes with the autosampler. With the chromatographic conditions listed in [Table 17](#), toluene elutes at approximately two minutes.

**Table 17.** Chromatographic conditions for toluene

Parameter	Setting
Mobile phase	80:20 methanol/water
Flow rate	1 mL/min
Column	100 × 4.6 mm, C-18 column, 5 µm particle size, or equivalent
Temperature	Ambient
Wavelength	260 nm, 1 nm bandwidth for the PDA detector

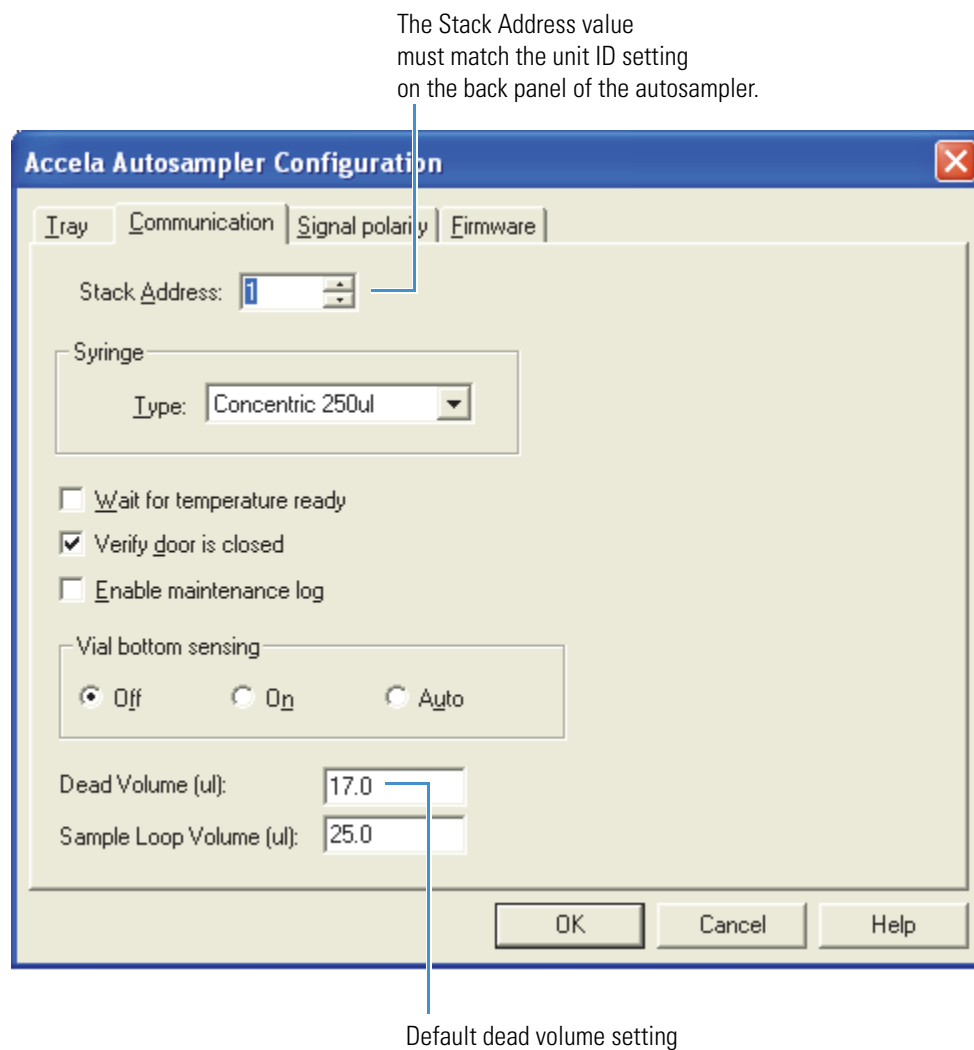
2. Change the value for the Dead Volume autosampler configuration parameter. Start with a value of **15**.

[Figure 83](#) shows the Communication page of the Accela Autosampler Configuration dialog box for Thermo Foundation Instrument Configuration, and [Figure 84](#) on [page 121](#) shows the Accela AS Configuration dialog box in the ChromQuest data system. The default dead volume value is 17.0. The manufacturer determines the volume of the tubing used to produce each lot of transfer tubes (see [Figure 82](#) on [page 118](#)) and places a label on each tube.

## 6 Routine Troubleshooting

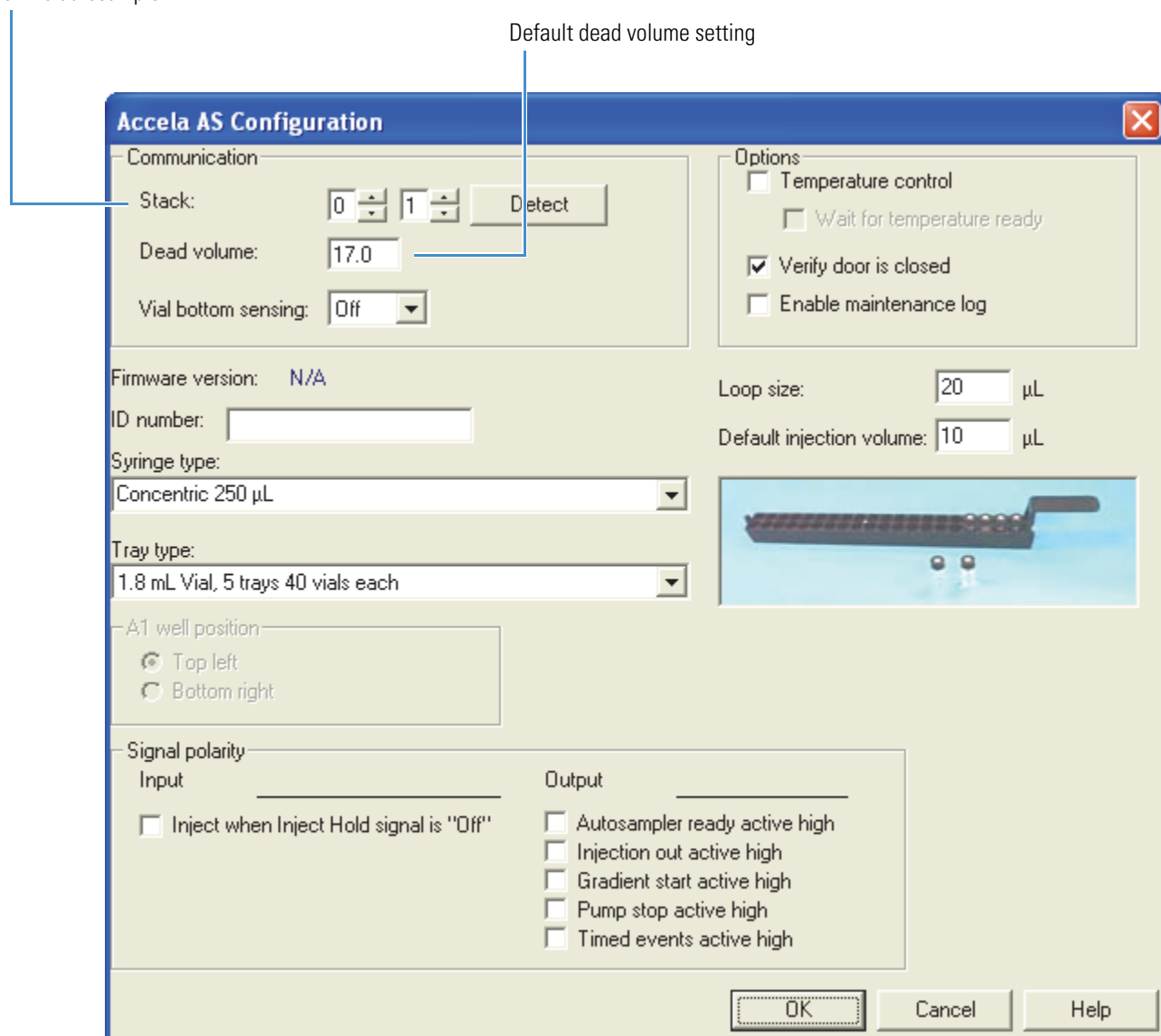
### Determining the Transfer Tubing Volume

**Figure 83.** Communication page (Thermo Foundation Instrument Configuration)



**Figure 84.** Accela AS Configuration dialog box (ChromQuest data system)

The Stack value must match the unit ID setting on the back panel of the autosampler.



3. From the Xcalibur or ChromQuest data system, inject 1 µL of sample using the no waste injection mode.
4. Repeat [step 2](#) and [step 3](#), increasing the dead volume by 1 µL each time until you have data points from 15 to 23 µL.
5. Plot the peak area versus dead volume. Check for an increase in peak area until it reaches a plateau.

Due to injection variability, the plateau might not be flat. Select the dead volume where the maximum is first reached.



## Consumables and Service Parts

A consumable item is an item that is expected to wear with use or that comes in contact with system fluids or samples. As a result, you must periodically replace a consumable item. A service part is a subassembly of the autosampler. Normally, Thermo Fisher Scientific service representatives or other qualified personnel replace a service part. This chapter provides a comprehensive listing of consumables and Accela Autosampler service parts that you can order and replace.

This chapter also includes an itemized list of the parts in the Accela System Kit. This kit contains the hardware required to interconnect the system modules and the instrument device drivers required to operate the modules. The Accela System Kit is not packaged with the Accela Autosampler. You must order it separately or as part of a system bundled with either the Xcalibur or ChromQuest data system.

**Note** To control the Accela Autosampler, you must have the Xcalibur or ChromQuest data system and the Accela device drivers.

- For the Xcalibur data system, the Accela device drivers are provided on the LC Devices software CD.
- For the ChromQuest 4.2 data system, the Accela device drivers are provided on the Accela Add-On Device Drivers CD.
- For the ChromQuest 5.0 data system, the Accela drivers are provided on the ChromQuest data system CD.

### Contents

- [Consumables](#)
- [Service Parts](#)
- [Accela AS Accessory Kit](#)
- [Accela System Kit](#)

## Consumables

These parts are consumables for the Accela Autosampler. The sample loops are compatible with the Valco injection valve.

Accessory Kit, Accela Autosampler	60357-62001
Assembly, needle, inert	60357-60017
Assembly, needle tubing	60053-60102S
Assembly, syringe valve	A3692-010
Assembly, transfer tube, 0.012 in. ID	60053-60014
Cooling adapter, 96 well	60053-20002
Ferrule, Valco zero dead volume for 1/16 in. OD tubing	00101-18122
Filter, flush solvent	A4258-010
Grease, silicon/Teflon (for lead screw)	00301-01910
Kit, Maintenance Accela AS	60357-62002
Kit, Needle Tubing	60053-62043
Kit, Wash Bottle	60053-62009
Lubricant, Tri-flow	1611-0030
Nut, compression, long, 10-32, 1/16 in. OD tube, Rheodyne.	00101-07-00001
Nut, compression, 0.45 in. length, for 1/16 in. OD tubing, 10-32 thread, stainless steel	2522-1880
Plunger, replacement, concentric, 100 µL	F1123-010
Plunger, replacement, concentric, 250 µL	F1123-020
Plunger, replacement, concentric, 500 µL	F1123-030
Port, needle	60053-20031
Reservoir vials, 16 mL	00301-07527
Retainer, needle port (injection port)	60053-10035
Ring, bearing (Rheodyne injection valve)	00109-99-00022
Sample loops for the Valco injection valve	
Sample loop, 5 µL	00109-99-00007
Sample loop, 10 µL	00109-99-00008
Sample loop, 20 µL	00109-99-00009
Sample loop, 25 µL	00109-99-00010
Sample loop, 50 µL	00109-99-00011
Sample loop, 100 µL	00109-99-00012
Sample loop, 500 µL	00109-99-00013
Sample loop, 1000 µL	00109-99-00014
Sample loops for the Rheodyne injection valve	
Sample Loop, 5 µL	00109-99-00023
Sample Loop, 10 µL	00109-99-00024
Sample Loop, 20 µL	00109-99-00025
Sample Loop, 25 µL	00109-99-00026
Sample Loop, 50 µL	00109-99-00027
Sample Loop, 100 µL	00109-99-00028
Sample Loop, 500 µL	00109-99-00029
Sample Loop, 1000 µL	00109-99-00030

Consumables (continued)

Seal, rotor (for Rheodyne injection valve) . . . . .	00109-99-00021
Seal, rotor (for Valco injection valve) . . . . .	00110-03-00019
Stripper, vial . . . . .	60057-20085
Syringe, dual concentric, 100 µL . . . . .	F1100-010
Syringe, dual concentric, 250 µL . . . . .	F1100-020
Syringe, dual concentric, 500 µL . . . . .	F1100-030
Syringe, standard, 2500 µL (with needle tubing extension) . . . . .	60053-62002
Syringe, 2.5 mL . . . . .	60053-60006
Valve, injection (Valco) . . . . .	60357-60018S
Vial caps, 100 µL . . . . .	60053-40009
Tubing assembly, 2.5 mL syringe . . . . .	60053-60005
Vial kit, 1.8 mL w/250 µL insert, 100 per pack . . . . .	60053-62017
Vial kit, 2 mL, 100 count, includes caps and septa (2 each) . . . . .	A4954-010

## Service Parts

Normally, Thermo Fisher Scientific service representatives replace these service parts:

Assembly, XYZ arm . . . . .	60357-60015S
Assembly, tray compartment cooler . . . . .	60357-60014S
Assembly, tray compartment cooler fan . . . . .	F1110-010
Assembly, door left . . . . .	60057-60011S
Assembly, door right . . . . .	60057-60015S
Assembly, column oven . . . . .	60357-60011S
Assembly, column oven fan . . . . .	60357-63006
Assembly, column oven sensor . . . . .	F9050-010
Assembly, injection valve driver . . . . .	60357-60010S
Assembly, syringe drive . . . . .	60357-60013
Assembly, tray compartment temperature sensor . . . . .	F9090-010
Base, pod, z-axis . . . . .	F1033-010
Cable, injector sensor . . . . .	A3513-010
Cable, door LED . . . . .	60357-63002
Cable, temperature control . . . . .	F1002-010
Cable, DC column oven motor . . . . .	F1017-010
Cable, A/C to power supply for the temperature controlled zones . . . . .	F1079-010
Cable, input power to the power supply module . . . . .	F1080-010
Cable, backplane power . . . . .	F1082-010
Cable, DC power to the column oven . . . . .	F1083-010
Cable, DC power to the tray compartment cooler . . . . .	F1083-020
Cable, power to the injection valve driver . . . . .	F1116-010
Column clamp . . . . .	60357-60012S
Enclosure for the autosampler chassis . . . . .	60057-10055
Gasket, oven door . . . . .	60057-40003
Heat exchanger . . . . .	60057-20087
Kit, Autosampler Calibration . . . . .	60053-62001

Service Parts (continued)

Kit, Adjustable Arm Lifting Stop Bracket . . . . .	60053-62028
PCB, CPU spare . . . . .	60053-60049
PCB, Interconnect . . . . .	F9040-010
PCB, LED . . . . .	60057-61000
PCB, Column oven temperature control (Accela and Surveyor) . . . . .	60053-61071R
PCB, Tray compartment temperature control (Accela and Surveyor). . . . .	60053-61084R
PCB, XYZ arm motor. . . . .	F9045-010R
Power supply, main . . . . .	4004-0662
Power supply, option. . . . .	4004-0663
Switch, tray compartment door. . . . .	A3520-020
Wash station . . . . .	60057-40012

## Accela AS Accessory Kit

The Accela AS Accessory Kit (P/N 60357-62001) includes consumables (such as vials, fittings, and test mixtures) as well as durable accessories (such as microplates, tray adapters, tools, and a power cord). The kit contains the following items:

Bottle, 16 mL, includes cap for sample prep (4 each) . . . . .	00301-07527
Cable, shielded, Ethernet, CAT-5, 7 ft length . . . . .	70111-63302
Carrier, microwell, short, 0.32 in. height. . . . .	60053-20004
Carrier handle for microwell carrier. . . . .	60053-20003
Carrier, microtitre, 1.26 in. height. . . . .	N/A
Carrier handle for microtitre carrier. . . . .	N/A
Clamp, waste tube. . . . .	N/A
Clip, microwell handle . . . . .	F1072-010
Connector, plug, 8-position, 3.8 mm pitch, minicombicon (2 each). . . . .	00004-02511
Fuse, 5 A, 250 V, 5 × 20 mm, time lag, (4 each) . . . . .	5101-1856
Procedure, microplate carrier assembly instructions. . . . .	60053-97024
Screw, cross-recessed, 100 degree, flat countersunk head, type 1, 6–32 × 0.375 in. length . . . . .	N/A
Screw, 4–40 × 1/4 in. length, pan head, stainless steel . . . . .	N/A
Screw, pan head, 4–40 × 1/4 in. length, stainless steel, for tray adapters (5 each) . . . . .	N/A
Test mixture, pkg., 1 mL, 5 count, for performance qualification . . . . .	A4991-010
Test mixture, pkg., 1 mL, 5 count, dilution, for performance qualification . . . . .	A5135-010
Tray adapter for 300 µL vial (5 each). . . . .	F1124-010
Tubing, 1 L bottle. . . . .	N/A
Tubing, convoluted, for autosampler solvent waste . . . . .	F5034-050
Vial kit, screw top, 2 mL, 100 count, includes caps and septa (2 each) . . . . .	A4954-010
Wrench, combination, 1/4 × 5/16 in. . . . .	5401-0400

**Note** The Accela Autosampler ships with five sample vial trays installed in the tray compartment. Each tray holds 40 standard, 1.8 mL vials arranged in two rows of 20.

The part number for the tray is F1094-010S.

## Accela System Kit

The Accela System Kit, P/N 60057-60060 revision F, contains the cables, tubing, fittings, and so on used to interconnect the system modules.

5-port Ethernet switch, 5 port, 10/100 Base-T, 100 - 240 V	00825-01-00024
Cable, Ethernet with two ferrites	97355-98006
Cable, system interconnect cable, 7-connector	60053-63034
Ferrule, Valco zero dead volume for 1/16 in. OD tubing, (quantity 12)	00101-18122
Marker letter A, clip on for 1/8 in. OD tubing	N/A
Marker letter B, clip on for 1/8 in. OD tubing	N/A
Marker letter C, clip on for 1/8 in. OD tubing	N/A
Marker letter D, clip on for 1/8 in. OD tubing	N/A
Nut, compression, 0.45 in. length, for 1/16 in. OD tubing, 10-32 thread, stainless steel (quantity 12)	2522-1880
Solvent bottle, 1 liter (quantity 4)	1413-0430
Solvent bottle caps (outer portion) (quantity 4)	A0343-010
Solvent bottle cap adapter (inner portion) (quantity 4)	A3191-010
Solvent bottle label set	A4158-020
Solvent bottle holder, solvent platform	60057-60014
Tubing, stainless steel, 0.005 in. ID × 1/16 in. OD, 10 cm length	00301-01-00008
Tubing, stainless steel, 0.005 in. ID × 1/16 in. OD, 20 cm length (to connect the Accela Pump outlet to the inlet of the Accela Autosampler heat exchanger)	00301-01-00009
Tubing, stainless steel, 0.005 in. ID × 1/16 in. OD, 26 cm length	00028-01-00035
Tubing, stainless steel, 0.005 in. ID × 1/16 in. OD, 60 cm length	00028-01-00039
Vial kit, clear vials with 1.8 mL capacity, black screw-on caps, 100 vials and caps per package (quantity 2)	A4954-010
Instrument control software, LC Devices (for use with the Xcalibur data system and several other Thermo Scientific mass spectrometry applications)	60257-62005
Instrument control software, Thermo pumps add-on for the ChromQuest 5.0 data system	CHROM-93034
Instrument control software, Accela detectors add-on for the ChromQuest 5.0 data system	CHROM-98036
Instrument control software, Accela Open Autosampler add-on for the ChromQuest 5.0 data system	CHROM-98037
Instrument control software, for the Accela Open Autosampler PAL loader and object manager	CHROM-98035



## Firmware Updates

Periodically, upgrades to the Accela Autosampler firmware might become available. In anticipation of future upgrades, both the Xcalibur and ChromQuest data systems come with the Accela Firmware Upgrade utility, which you can use to download firmware files to your Accela instrument modules. Firmware upgrade files have a .bin extension.

For the Xcalibur 2.0.7 or earlier data system and the Thermo Foundation application, the current firmware files and the Accela Firmware Upgrade utility are automatically installed to your personal computer during the installation of the data system.

For the ChromQuest data system, you can access the utility by choosing **Start > Programs > Chromatography > Accela Firmware Upgrade Utility**.

### Contents

- [Preparing the Autosampler for a Firmware Download](#)
- [Downloading Firmware to the Autosampler](#)

## Preparing the Autosampler for a Firmware Download

### ❖ To prepare the autosampler for a firmware download

1. Make sure you have the Accela AS firmware files that you intend to download and the Accela Firmware Upgrade Utility on your computer.

For the Xcalibur 2.0.7 or earlier data system, these files reside in the following folder:

*drive:\Xcalibur\system\Accela Firmware*

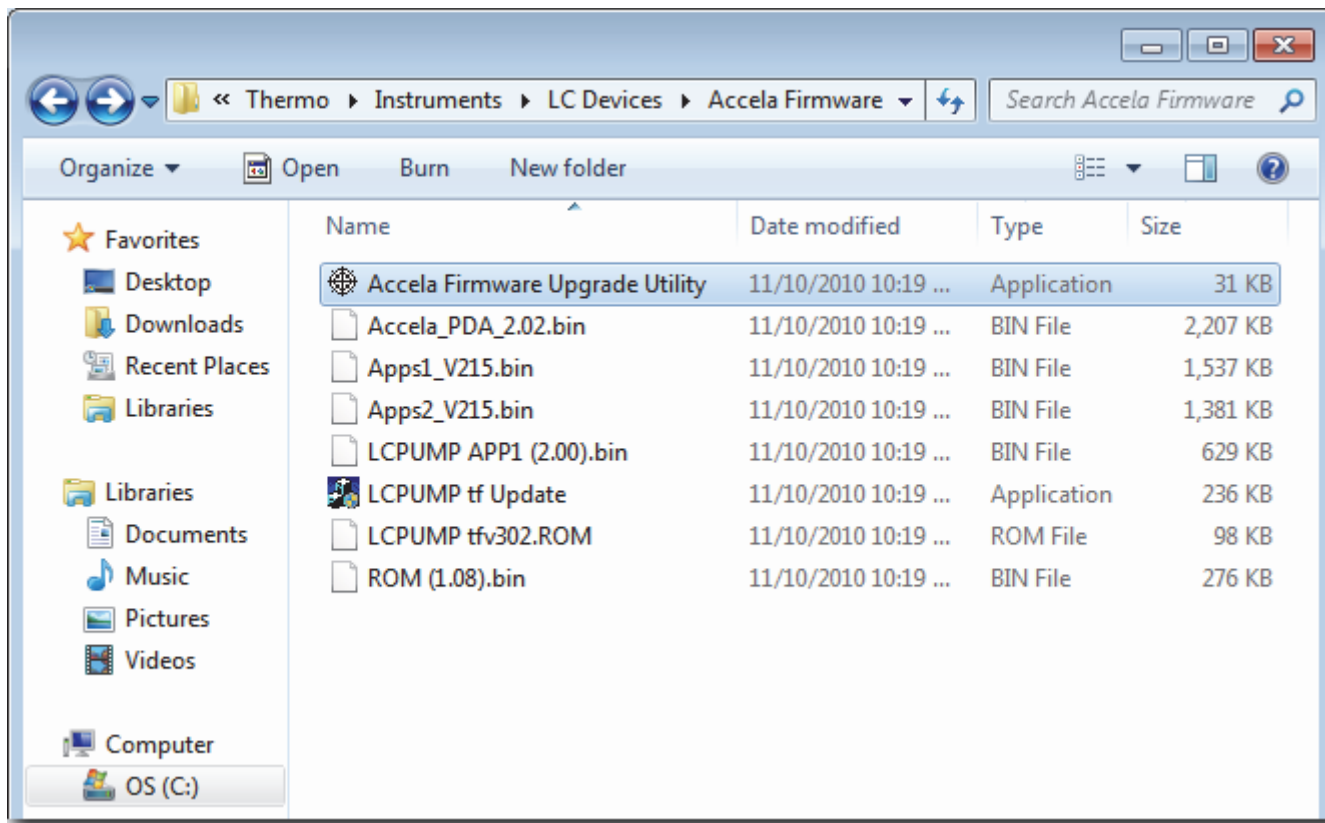
For the Thermo Foundation 1.0 or later application, these files reside in the following folder (see [Figure 85](#)):

*drive:\Thermo\Instruments\LC Devices\Accela Firmware*

## B Firmware Updates

Preparing the Autosampler for a Firmware Download

**Figure 85.** Accela Firmware folder installed with the Accela devices on the LC Devices CD



2. Make a note of the current settings of the rotary switches on the back panel of the Accela Autosampler.

At the conclusion of this procedure, you return the switches to these settings.

3. Make sure that your autosampler is connected to the computer through the standard Ethernet connection.
4. Turn off the power to the Accela Autosampler.
5. Use a small, flat-head screwdriver to set the rotary switches on the back panel of the autosampler to 00.
6. Turn the autosampler power on.

The Communication LED blinks amber to confirm that the Accela Autosampler is configured for downloading the firmware.

## Downloading Firmware to the Autosampler

### ❖ To download firmware to the Accela Autosampler

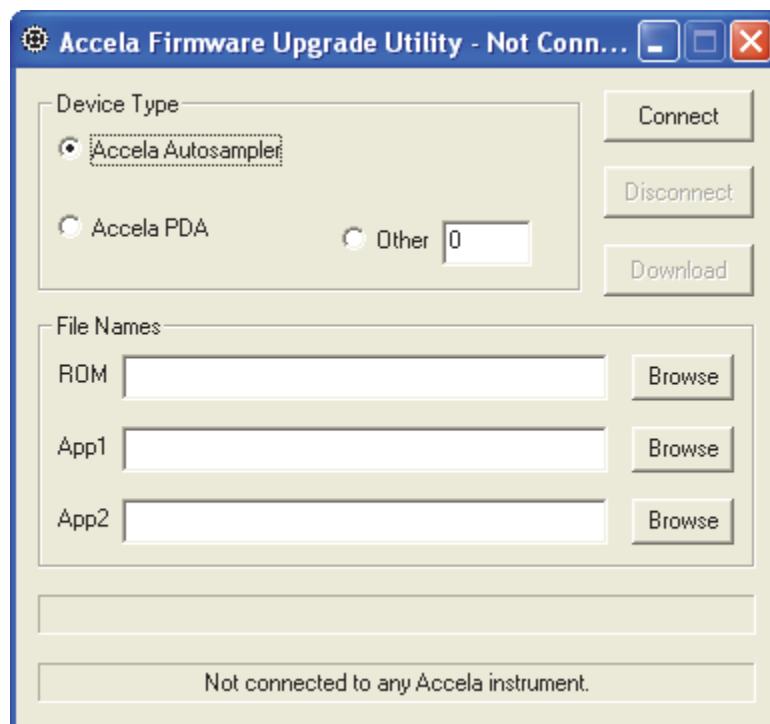
1. Start the Accela Firmware Upgrade Utility by doing one of the following:
  - For the Xcalibur data system, browse to the following directory, and then double-click **Accela Firmware Upgrade Utility.exe** file.

*drive:\Xcalibur\system\Accela Firmware*

- For the ChromQuest data system, from the computer desktop, choose **Start > Programs > Chromatography > Accela Firmware Upgrade Utility**.

The Accela Firmware Upgrade Utility window opens (see [Figure 86](#)).

**Figure 86.** Accela Firmware Upgrade Utility window, showing the Accela Autosampler device selected



**CAUTION** Avoid interrupting the firmware download process. After you click Connect, do not turn off the power to the Accela Autosampler Plus or close the Accela Firmware Upgrade Utility window until the download process is finished. If you terminate the connection during the download process or lose power to the autosampler, contact your local Thermo Fisher Scientific representative. The firmware board will need to be reprogrammed.

2. In the Accela Firmware Upgrade Utility window, initiate communication between the utility and the Accela Autosampler:
  - a. Under Device Type, select the **Accela Autosampler** option (see [Figure 86](#)).
  - b. Click **Connect**.

The status display at the bottom of the Accela Firmware Upgrade Utility window indicates that a connection has been made.

3. Under File Names, select the appropriate firmware files for the Accela Autosampler:

- a. For the ROM box, click **Browse** and select **ROM(108).bin**.

The file name appears in the ROM box.

- b. For the App1 box, click **Browse** and select **Apps1\_V2.15.bin**.

The file name appears in the App1 box.

- c. For the App2 box, click **Browse** and select **Apps2\_V2.15.bin**.

The file name appears in the App2 box.

**IMPORTANT** You must select a *ROM* file, an *APP1*, and an *APP2* file. If you do not download these files together, your Accela AS will not work properly when you return it to normal operation.

4. After you select the appropriate firmware files, click **Download** and wait for the download to finish.

The utility notifies you when the download is complete.

**Note** When the Download Completed Successfully message appears, you can safely turn off the power to the autosampler and close the Accela Firmware Upgrade Utility.

5. Return the autosampler to normal operation after you finish upgrading the firmware as follows:

- a. Close the Accela Firmware Upgrade Utility to terminate the connection with the Accela Autosampler.
- b. Turn off the power to the Accela Autosampler.

**IMPORTANT** Make sure to turn the Accela Autosampler power off before adjusting the rotary switches.

- c. Set the rotary switches back to their original settings.

**IMPORTANT** The Accela Autosampler will not connect to the Xcalibur data system when the rotary switch address is set to 00.

- d. Turn on the Accela Autosampler power to resume normal operation.

## Quick Reference Guides

This appendix contains the following two-page quick reference guides:

- [Replacing the Rotor Seal in the Rheodyne Valve](#)
- [Replacing the Rotor Seal in the Valco Valve](#)
- [Legacy Versions of the Accela Autosampler](#)
- [Using the Xcalibur Direct Control Commands](#)
- [Using the ChromQuest Direct Commands](#)



Replacing the rotor seal in the injection valve requires these tools and materials:

Tools and materials	Part number
Rotor seal for the Rheodyne injection valve	00109-99-00021
Rotor seal for the Valco injection valve	00110-03-00019
9/64 in. L-hex wrench	N/A
#2 Phillips screwdriver	N/A
1/4 in. open-end wrench	N/A



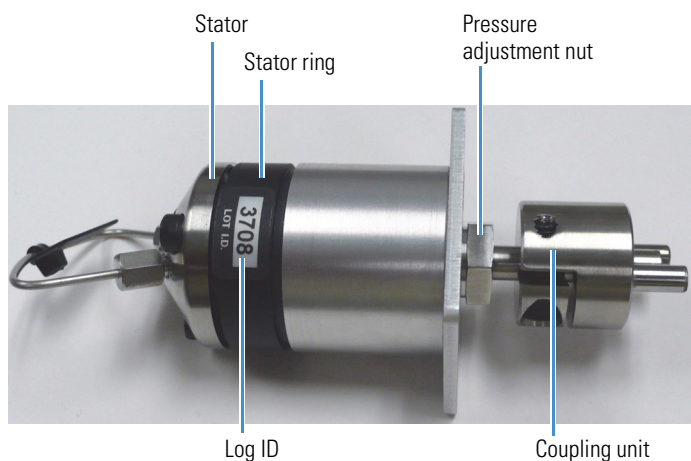
# Replacing the Rotor Seal in the Rheodyne Valve

Rheodyne valves shipped with earlier versions of the autosampler.

To replace the rotor seal, follow these steps:

- [Step 1: Removing the Injection Valve](#)
- [Step 2: Disassembling the Injection Valve](#)
- [Step 3: Installing a New Rotor Seal](#)
- [Step 4: Reassembling the Injection Valve](#)
- [Step 5: Reinstalling the Injection Valve](#)

The rotor seal forms a high-pressure seal between the stator and the rotor. Replace the rotor seal when leaking occurs between the stator and the stator ring or when you notice a decrease in injection precision.



The lot ID sticker on the stator ring identifies the week and year (WWYY) of the manufacture date.

Each valve has a pressure adjustment nut that is factory adjusted to the optimal pressure setting. Depending on the manufacture date, you can identify the optimal pressure setting as follows:

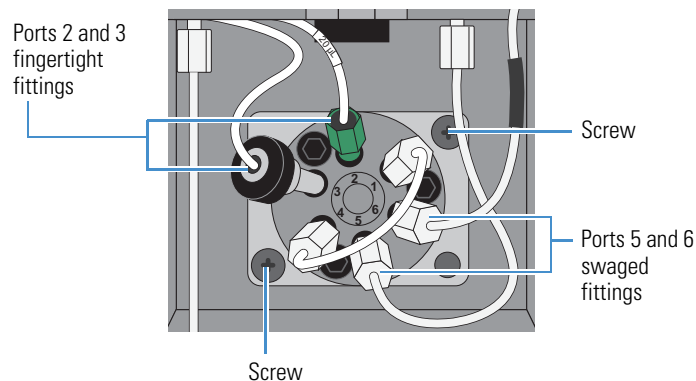
- For valves manufactured on week 38 of 2009 or later, the pressure adjustment nut is fixed at the optimal pressure setting.
- For injection valves manufactured from week 37 of 2008 to week 37 of 2009, the alignment of the factory-applied, red mark on the valve body and the dimple on the pressure adjustment nut corresponds to the optimal pressure setting for the valve.
- For injection valves manufactured before week 37 of 2008, the factory-applied red marks do not correspond to the optimal pressure setting. You must make your own marks.

Manufacture date	Alignment markings	Adjustable pressure nut
Initial release to week 36 of 2008	No	Yes
Week 37 of 2008 to week 37 of 2009	Yes	Yes
Week 38 of 2009 or later	No	No

## Step 1: Removing the Injection Valve

### ❖ To remove the injection valve from the autosampler

1. Disconnect the fingertight fittings from ports 2 and 3.
2. Using a 1/4 in. open-end wrench, loosen and remove the swaged fittings from ports 5 and 6.
3. Using a #2 Phillips screwdriver, loosen and remove the two screws that secure the valve to the autosampler, and then pull the valve out of the autosampler.

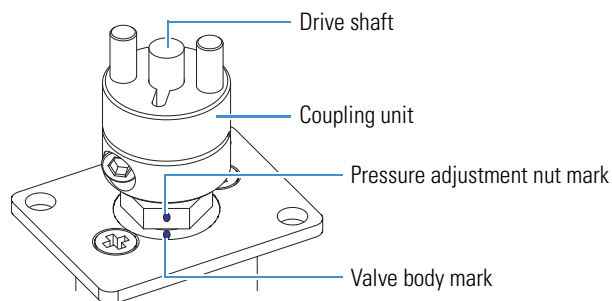


## Step 2: Disassembling the Injection Valve

### ❖ To disassemble the injection valve

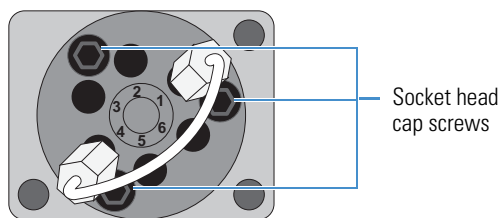
1. Determine the manufacture date of the valve.
2. For valves manufactured before week 37 of 2008, make reference marks on the pressure adjustment nut and the valve body to identify the current alignment.

After you replace the rotor seal and reassemble the valve, check the alignment of these marks to ensure that the position of the pressure adjustment nut is unchanged.



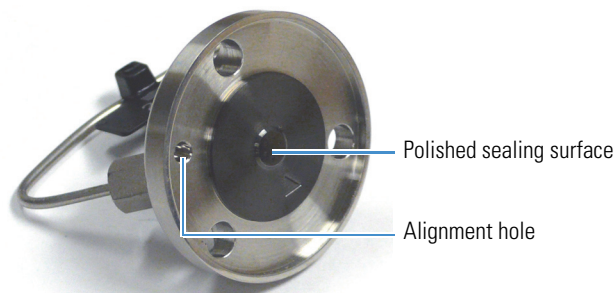
**CAUTION** Do not remove the coupling unit from the drive shaft of the injection valve. If you do remove the coupling unit, return the valve to Thermo Fisher Scientific for realignment.

- Using a 9/64 in. hex wrench, remove the three socket head cap screws that secure the stator to the valve.



**CAUTION** The polished (sealing) surface of the stator contains six easily damaged ports. Avoid touching this polished surface as you remove the stator from the injection valve. Do not place the polished surface face down on a hard surface.

- Pull the stator off the valve. Place it on its side on a clean surface.

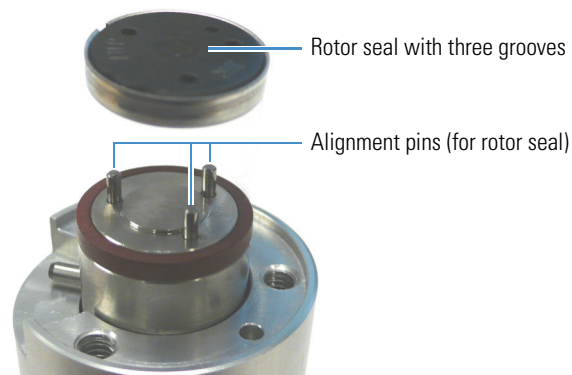


- If the polished surface of the stator is scratched, replace the valve.
- Pull the stator ring off the valve.
- Pull the rotor seal off the three pins on the drive shaft.
- Inspect the valve components for contamination. Clean as necessary.

### Step 3: Installing a New Rotor Seal

#### ❖ To install a new rotor seal

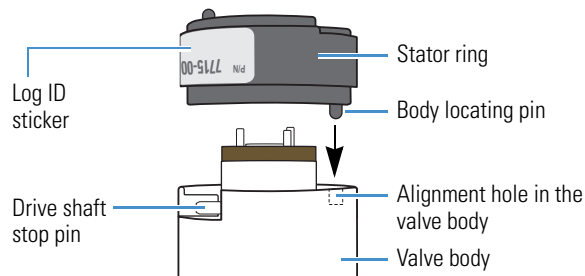
Hold the rotor seal with the engraved flow passages facing away from the drive shaft and mount the rotor seal onto the drive shaft's three alignment pins. The pins align with the rotor seal in only one way.



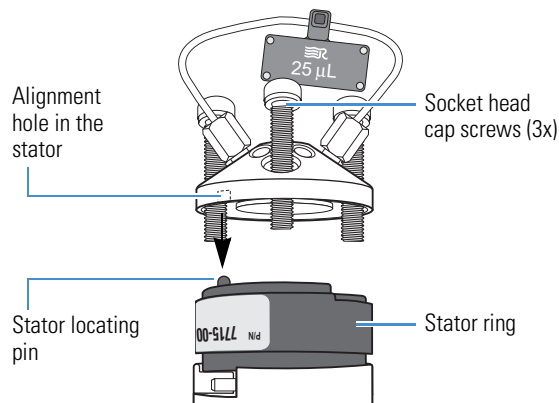
### Step 4: Reassembling the Injection Valve

#### ❖ To reassemble the injection valve

- Ensure that the drive shaft stop pin is positioned within the slot in the valve body.
- To mount the stator ring onto the valve body, align the body locating pin with the alignment hole in the valve body. Then insert the body locating pin into the alignment hole.



- To mount the stator onto the stator ring, hold the stator with its polished surface facing the stator ring. Align the alignment hole in the stator with the stator locating pin on the stator ring. Then insert the locating pin into the alignment hole.

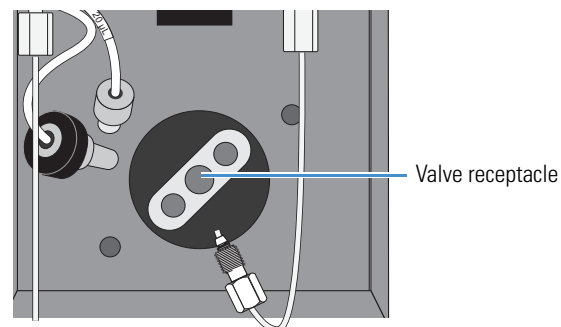


- Insert the three socket head cap screws into the stator.
- Using a 9/64 in. L-hex wrench, tighten each screw a little at a time, keeping the stator surface parallel to the stator ring surface.
- If you have an adjustable torque wrench with a 1/4 in. shaft and a hex driver attachment, evenly torque the three socket head cap screws to 20 inch-pounds.
- For valves manufactured before week 38 of 2009, ensure that the position of the pressure alignment nut is unchanged.

### Step 5: Reinstalling the Injection Valve

#### ❖ To reinstall the injection valve

- Align the holes in the valve plate with the two small holes to the left and right of the valve receptacle, and then insert the valve drive shaft into the valve receptacle.



- Using a #2 Phillips screwdriver, tighten the screws that secure the valve to the autosampler.
- Reconnect the transfer tubing to port 2 and the waste tubing to port 3. Hand-tighten the fittings.
- Reconnect the heat exchanger outlet to port 5. Hand-tighten the fitting, and then tighten the fitting an additional 90 degrees (1/4 turn) with a 1/4 in. open-end wrench.
- Start the solvent flow from the LC pump, and check for leaks.

# Replacing the Rotor Seal in the Valco Valve

The rotor seal is a disk with three engraved slots that forms a high-pressure seal with the stator. Replace the rotor seal when you notice a leak between either the stator and the rotor or the adjacent ports of the injection valve, or when you notice a decrease in injection precision.

## Contents

- [Step 1: Removing the Injection Valve](#)
- [Step 2: Disassembling the Injection Valve](#)
- [Step 3: Cleaning the Stator](#)
- [Step 4: Installing the Rotor Seal](#)
- [Step 5: Reinstalling the Injection Valve](#)

Replacing the rotor seal requires these tools.

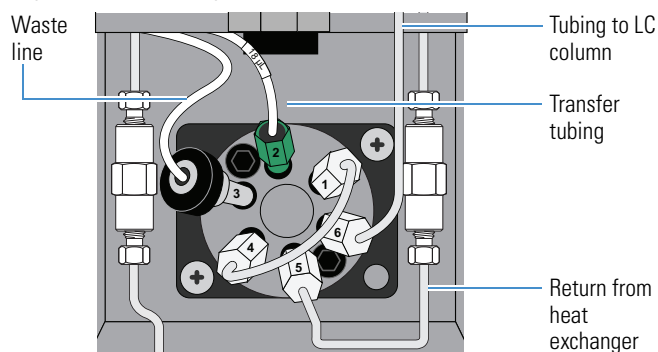
Tool	Use
1/4 in. open-end wrench	To remove the tubing from injection valve ports 5 and 6
9/64 in. hex wrench	To disassemble the injection valve
#2 Phillips screwdriver	To disconnect the valve from the autosampler

**IMPORTANT** Because component cleanliness affects the useful life of the injection valve, replace the rotor seal in a clean environment.

## Step 1: Removing the Injection Valve

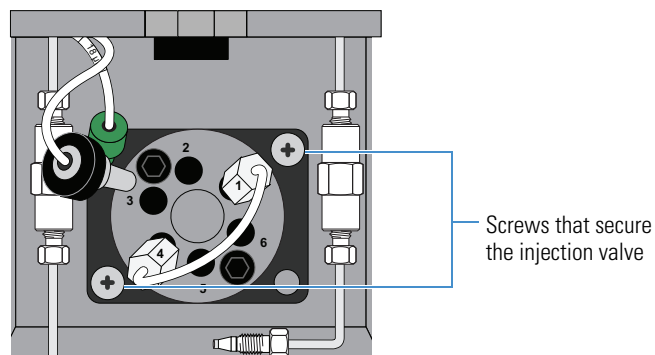
### ❖ To remove the injection valve

1. Disconnect the waste tubing from port 3 of the injection valve.
2. Disconnect the transfer tubing from port 2 of the injection valve.
3. Using a 1/4 in. open-end wrench, disconnect the 1/16 in. ID high-pressure tubing from ports 5 and 6.



Note: This drawing shows the current heat exchanger.

4. Using a #2 Phillips screwdriver, remove the two screws that secure the injection valve to the autosampler.



5. Slide the injection valve out of the autosampler.

## Step 2: Disassembling the Injection Valve

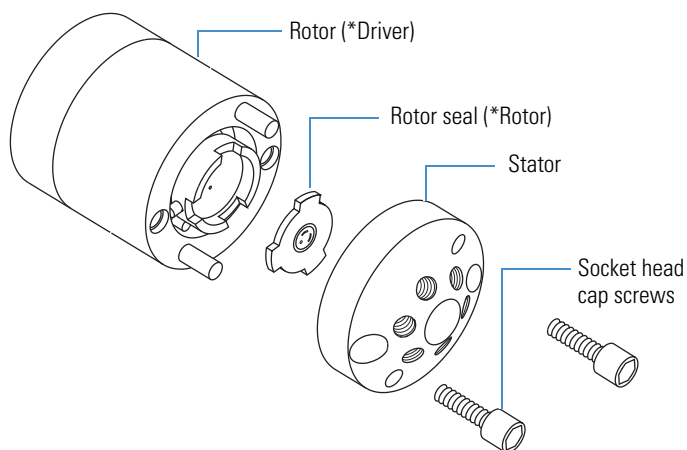
### ❖ To disassemble the injection valve

1. Using a 9/64 in. L-hex wrench, remove the two socket head cap screws that secure the stator to the stator ring and the valve body.



**CAUTION** The polished (sealing) surface of the stator contains six ports that excess handling can easily damage. As you remove the stator from the injection valve, avoid touching this polished surface, and never place the polished surface face down on a hard surface.

\*Valco Instruments Co. terminology



2. Gently pry the rotor seal away from the rotor.
3. Examine the sealing surface of the rotor seal for scratches. If scratches are visible, replace the rotor seal.

### Step 3: Cleaning the Stator

#### ❖ To clean the stator

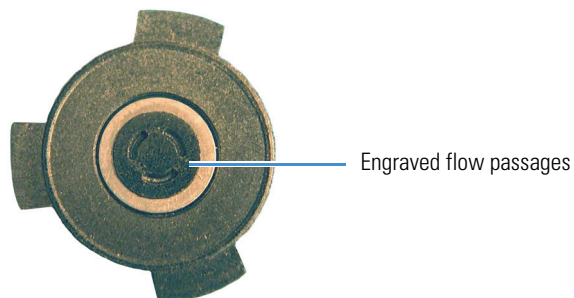
1. Inspect the stator to determine if it requires cleaning.
2. If the stator is dirty, swab it with HPLC-grade methanol. If more stringent cleaning is required, use a sonication bath.
3. Inspect the remaining valve components for contamination. Clean as necessary.

**IMPORTANT** If the stator is scratched, replace it. Scratches can damage the rotor seal and cause cross-port leaks.

### Step 4: Installing the Rotor Seal

#### ❖ To install a new rotor seal

1. Replace the rotor seal in the rotor, making sure that the rotor sealing surface with its engraved flow passages is facing out. The pattern is asymmetrical to prevent improper placement.

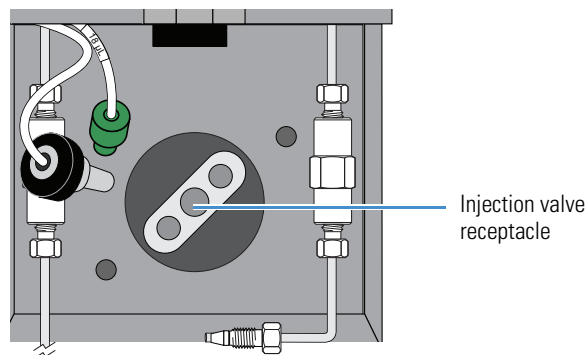


2. Replace the stator.
3. Insert the two socket head screws.
4. Alternating between the screws, slowly tighten the screws until both are snug. Do not overtighten them.

### Step 5: Reinstalling the Injection Valve

#### ❖ To reinstall the injection valve

1. Align the drive shaft and the two prongs of the coupling unit with the three holes in the injection valve port located in the lower portion of the column oven compartment. Then insert the injection valve into the receptacle.



2. Align the holes in the steel plate of the injection valve with the small holes next to the injection valve receptacle.
3. Using the two screws that you removed in [step 4](#) on [page 137](#), secure the injection valve to the autosampler.

4. Reconnect the solvent lines as follows:

- Hand-tighten the transfer tube fitting to port 2 and the waste tube fitting to port 3. Never use a wrench to tighten these fittings.



**CAUTION** Never use a wrench to tighten the transfer tube fitting. Over-tightening the fitting can do the following:

- Restrict the end of the tubing, which leads to less sample reaching the sample loop and results in smaller than expected peak areas or blank injections. A restriction in the end of the tubing can also cause the syringe to make a grinding sound during an injection sequence.
  - Strip the threads on the fitting, which leads to solvent leaks.
- Hand-tighten the waste tube fitting to port 3.
  - Press the end of the return tubing from the heat exchanger to the bottom of port 5 as you hand-tighten the high-pressure fitting. Then use a wrench to tighten the fitting by an additional 1/4 turn.
  - Using high-pressure tubing and two high-pressure fittings, reconnect the LC column to port 6 of the injection valve.

**Note** To reconnect tubing with a pre-swaged stainless steel fitting to a valve port, hand-tighten the fitting as you press the tubing against the bottom of the port, and then use a wrench to tighten the fitting by an additional 1/4 to 1/2 turn.

To connect tubing with a two-piece stainless steel fitting to a mating port, press the tubing against the bottom of the port as you hand-tighten the fitting. Then tighten the fitting by an additional 3/4 turn with a wrench. Once you use the wrench to tighten the fitting, the ferrule portion of the two-piece fitting is permanently connected to the tubing.

5. Turn on the solvent flow from the LC pump and check for leaks.

# Legacy Versions of the Accela Autosampler

For information about legacy versions of the Accela Autosampler, see these topics:

## Content

- [Hardware Changes](#)
- [Heat Exchanger Plumbing](#)

## Hardware Changes

Since the introduction of the Accela Autosampler, Thermo Fisher Scientific has replaced the Rheodyne injection valve with a Valco injection valve and modified the heat exchanger design.

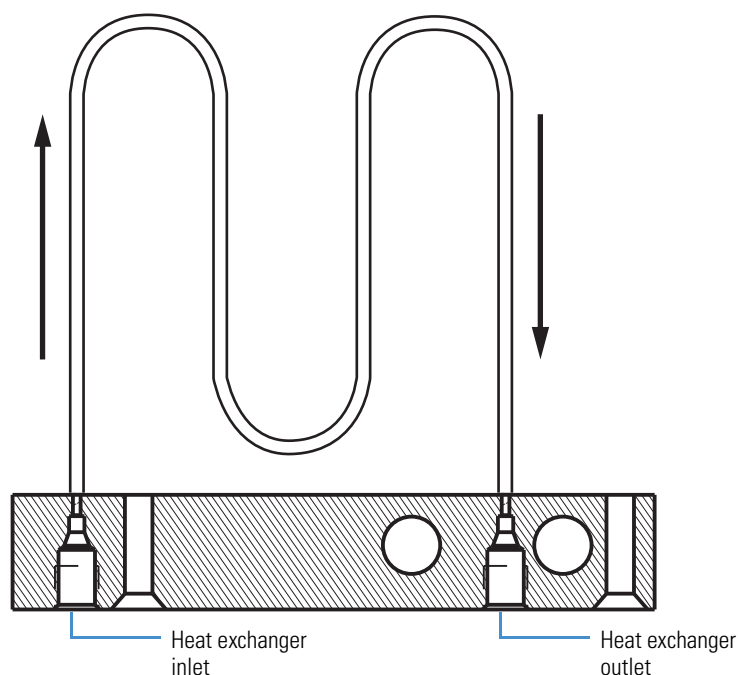
For information about maintaining the Rheodyne injection valve, see [“Replacing the Rotor Seal in the Rheodyne Valve”](#) on [page 135](#). You cannot replace the Rheodyne injection valve with the current Valco injection valve.

For information about making the plumbing connections to the original heat exchanger, see the next topic. If the heat exchanger requires replacement, order the current heat exchanger (P/N 60057-20087).

## Heat Exchanger Plumbing

The heat exchanger is located above the injection valve behind the metal plate that covers the column oven heater. The original heat exchanger had female fittings at each end of the tubing.

**Figure 1.** Heat exchanger schematic (original)



Follow these procedures to do the following:

- [To connect tubing to the heat exchanger inlet](#)
- [To remove a plug from the heat exchanger tubing](#)

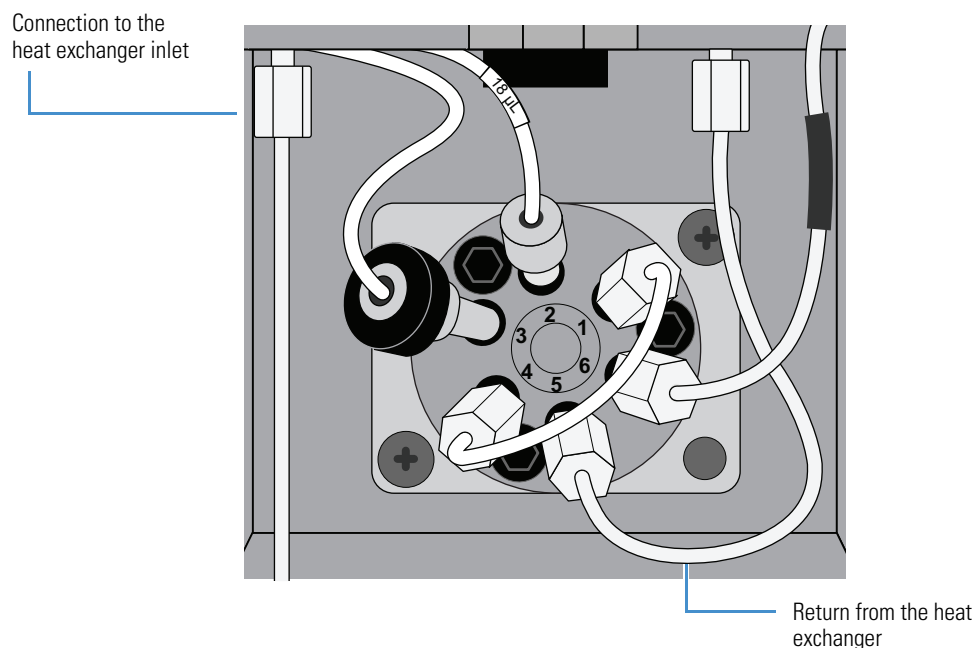
❖ **To connect tubing to the heat exchanger inlet**

1. Using a stainless steel, high-pressure fitting, connect a length of stainless steel 1/16 in. OD tubing to the heat exchanger inlet.

The heat exchanger inlet is an internally threaded port on the left side of the column oven compartment just above the injection valve.

2. Using a 0.25 in. open-end wrench, tighten the nut.

**Figure 2.** Heat exchanger plumbing connections



❖ **To remove a plug from the heat exchanger tubing**

1. Using a 1/4 in. open-end wrench, detach the tubing connected to both the inlet and the outlet of the heat exchanger.
2. Connect the tubing from the pump to the port on the right side of the heat exchanger.
3. Set the flow rate from the pump to 1 mL/min.
4. After you clear the plug, reconnect the pump to the inlet of the heat exchanger and reconnect the outlet of the heat exchanger to port 5 of the injection valve.

# Using the Xcalibur Direct Control Commands

## Direct Control Commands

The On/Off switch is the only manual control provided with the Accela Autosampler. To perform tasks, such as moving the XYZ arm to the back of the tray compartment, use the direct control commands in the Instrument Setup window or the tune application for your Thermo Scientific mass spectrometer.

Command	Description
Position arm to access tray	Moves the XYZ arm to the back of the tray compartment so that you can remove trays from or place trays into the tray compartment.  <b>Note.</b> If the tray compartment door is open and you selected the Verify Door Is Closed check box when you configured the autosampler, the autosampler does not execute this command until you close the tray compartment door.
Flush syringe	Flushes the needle tubing and the interior of the needle with flush solvent.
Flush syringe at Fill position	Flushes the needle tubing, the interior of the needle, and the sample loop with flush solvent.
Wash needle	Washes the exterior of the needle with solvent.
Needle removal	Sets the needle to the needle removal position.  <b>CAUTION.</b> To avoid damaging the needle, execute this command before you remove the needle.
Set oven temperature	Sets the temperature of the column oven compartment without downloading an instrument method. The allowable temperature range is 5 to 95 °C.  <b>Important.</b> Avoid setting the temperature above the boiling point of the mobile phase.
Set tray temperature	Sets the temperature of the tray compartment without downloading an instrument method. The allowable temperature range is 0 to 60 °C.
Turn off oven temperature	Turns off the oven temperature control, allowing the temperature of the column oven compartment to return to ambient.
Turn off tray temperature	Turns off the tray temperature control, allowing the temperature of the tray compartment to return to ambient.
Inject sample	Injects a sample. The available parameters are Vial, Volume, and Injection Mode.  The allowable vial or well entries depend on the tray configuration: <ul style="list-style-type: none"> <li>• For conventional trays, the allowable entries are A:01 to E:40.</li> <li>• For 96-well plates, the allowable entries are A:A1 to C:H12.</li> <li>• For 384-well plates, the allowable entries are A:A1 to C:P24.</li> </ul>
Move needle	Moves the XYZ arm to a specific vial or well location.
Set injector position	Switches the position of the injection valve. The injection valve has two positions: fill and inject.
Set syringe to removal position	Sets the syringe to its removal position.
Set syringe to home position	Sets the syringe to its home position.
Set Arm to Home Position	Moves the XYZ arm to its home position, which is just above the injection port.

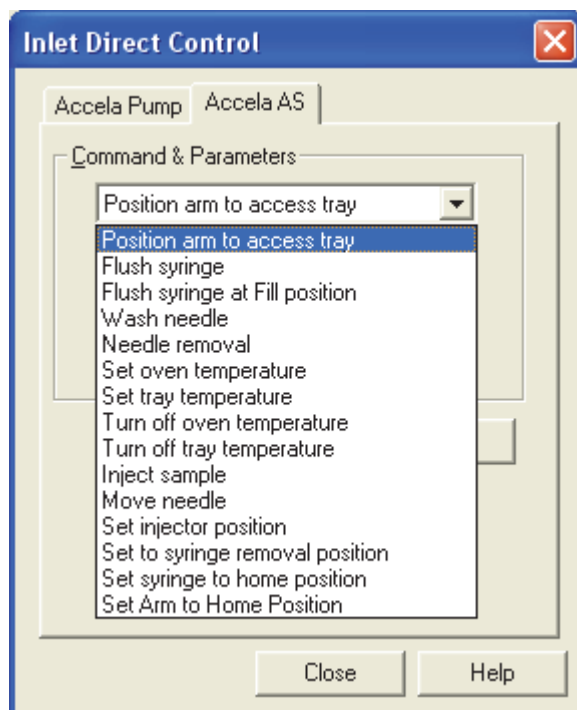
## Applying a Direct Command

You can access the direct control commands from the Xcalibur data system or the tune application for your mass spectrometer.

### ❖ To open the Inlet Direct Control dialog box from the tune application

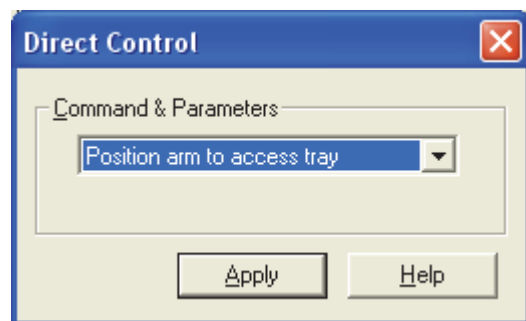
1. In the Tune window, choose **Setup > Inlet Direct Control**. The Inlet Direct Control dialog box appears with tabbed pages for each configured LC device.
2. Click the **Accela AS** tab.

The Accela AS page appears.



### ❖ To open the Direct Control dialog box from the Xcalibur Roadmap view

1. Click the **Instrument Setup** icon.  
The Instrument Setup window appears. The view bar on the left side of the window displays the configured instruments.
2. In the view bar, click the **Accela AS** icon. The Instrument Setup window for the autosampler appears.
3. From the menu bar, choose **Accela AS > Direct Control**. The Direct Control dialog box appears.



### ❖ To apply a direct command

1. In the Commands list, select a command.  
If the command requires additional parameters, these parameters appear below the Commands list. Make the appropriate entries and selections.
2. To execute the command, click **Apply**.

# Using the ChromQuest Direct Commands

## Direct Commands

The On/Off switch is the only manual control provided with the Accela Autosampler. To perform tasks, such as moving the XYZ arm to the back of the tray compartment, use the direct commands.

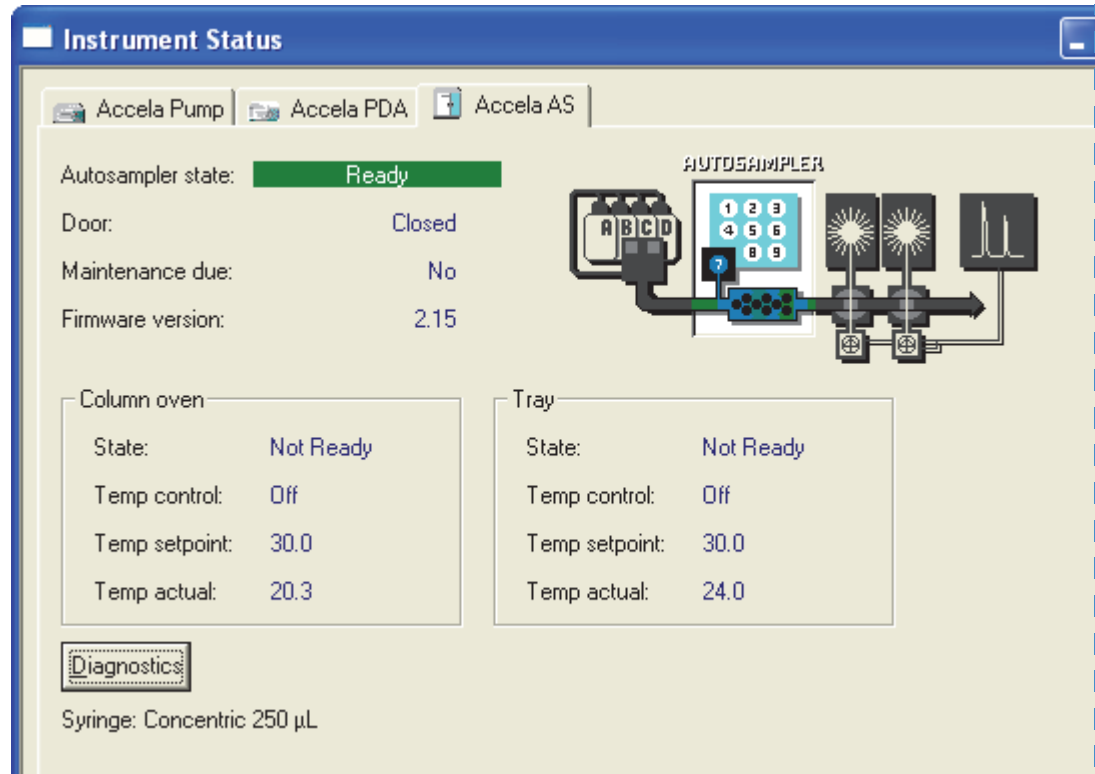
Command	Description
Position arm to access tray	Moves the XYZ arm to the back of the tray compartment so that you can remove trays from or place trays into the tray compartment. <b>Note.</b> If the tray compartment door is open and you selected the Verify Door Is Closed check box when you configured the autosampler, the autosampler does not execute this command until you close the tray compartment door.
Flush Syringe	Flushes the needle tubing and the interior of the needle with flush solvent.
Flush With Injection In Fill Position	Flushes the needle tubing, the interior of the needle, and the sample loop with flush solvent.
Set Oven Temperature	Sets the temperature of the column oven compartment without downloading an instrument method. The allowable temperature range is 5 to 95 °C. <b>Important.</b> Avoid setting the temperature above the boiling point of the mobile phase.
Set Tray Temperature	Sets the temperature of the tray compartment without downloading an instrument method. The allowable temperature range is 0 to 60 °C.
Turn Off Column Oven	Turns off the oven temperature control, allowing the temperature of the column oven compartment to return to ambient.
Turn Off Tray Temperature	Turns off the tray temperature control, allowing the temperature of the tray compartment to return to ambient.
Temperature Control Upload	Determines if the autosampler has the optional temperature control feature.
Wash Needle	Washes the exterior of the needle with solvent.
Move Needle	Moves the XYZ arm to a specific vial or well location.
Set Injector Position	Switches the position of the injection valve. The injection valve has two positions: fill and inject.
Initialize Hardware	Performs the following sequence of operations: <ol style="list-style-type: none"><li>1. Switches the two-way syringe valve to the flush bottle position.</li><li>2. Homes the syringe.</li><li>3. Sets the syringe plunger back to the ready position.</li><li>4. Switches the two-way syringe valve back to the needle position.</li><li>5. Homes the syringe.</li></ol> After the autosampler initializes, it goes into the Waiting for Download state.
Position Arm to Replace Needle	Sets the needle to the needle removal position. <b>CAUTION.</b> To avoid damaging the needle, execute this command before you remove the needle.
Position Syringe to Home	Sets the syringe to its home position.
Position Syringe for Removal	Sets the syringe to its removal position.
Go to Home	Moves the XYZ arm to its home position, which is just above the injection port.

## Submitting a Direct Command

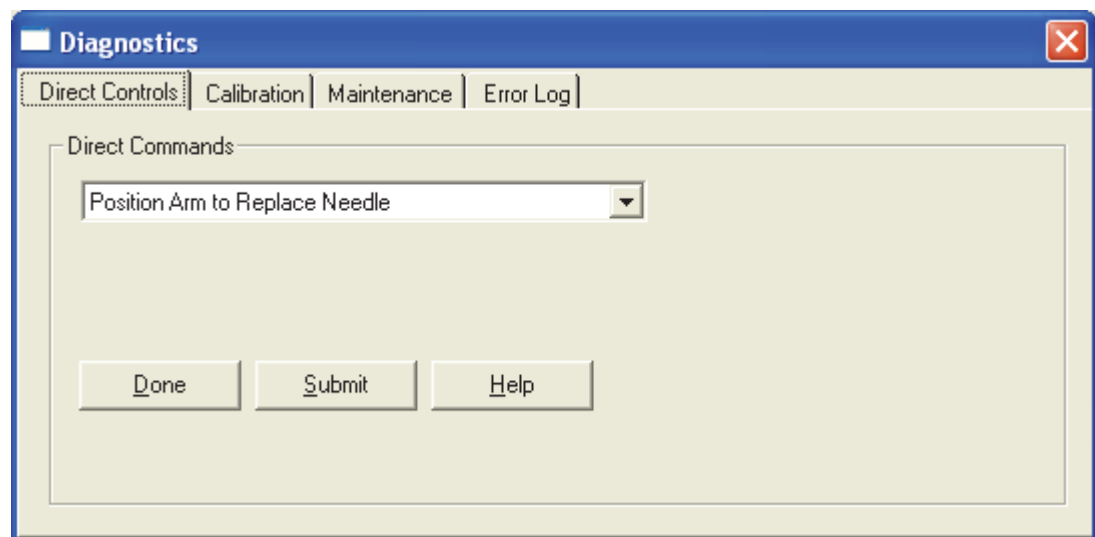
You can access the direct control commands from the Instrument Status window.

### ❖ To submit a direct command

1. In the online Instrument window, choose **Control > Instrument Status**. The Instrument Status window appears.
2. Click the **Accela AS** tab. The status page for the autosampler appears.



3. Click **Diagnostics**. The Diagnostics dialog box appears with the Direct Controls page displayed.



4. In the Direct Commands list, select a command.  
If the command requires additional parameters, these parameters appear below the Commands list.
5. Make the appropriate entries and selections.
6. To execute the command, click **Submit**.



# Index

## A

- Accela Firmware Upgrade Utility 131
- air bubbles
  - loaded into the sample loop for no waste injections 17
  - separating the sample from the transfer solvent in variable volume injections 24
- autosampler
  - calibration 47
  - diagnostics 101
  - lifting xx
  - loading 49
  - ordering with Accela System Kit 35
  - startup sequence 46
  - troubleshooting 109
  - updating firmware 131
  - validation information, Xcalibur data system 106

## B

- back panel connections 36

## C

- cables
  - Ethernet, connecting 39
  - system interconnect, connecting 37
- calibration, autosampler 47
- carrier trays for microwell plates 52
- carryover, sample
  - specification 32
  - troubleshooting 111
- CAUTIONS
  - Do not overtighten the transfer tube fitting 73
  - Do not place tall objects in the tray compartment 3
  - Do not remove the autosampler's housing 59
  - Do not remove the injection valve coupling unit 135
  - Do not touch the polished surface of the stator 64, 82
- chemicals, filtering and preparing 49
- chromatography, troubleshooting (table) 108

- ChromQuest data system
  - Accela AS Configuration dialog box 121
  - control 30
  - direct commands 143
  - firmware downloads 131
  - maintenance cycles, recording autosampler 98
- color-coded, precut stainless steel tubing 44
- column oven
  - description 15
  - temperature range 15
- compliance
  - FCC iii
  - regulatory iii
- compliance, WEEE v
- concentric dual syringe assembly. *See* syringe
- connections
  - back panel 36
  - injection valve 68
  - needle tubing 6
  - transfer tubing 11
  - wash bottle 41
- covers
  - for 384-well microplates 57
  - for 96-well microplates 55
  - types to avoid 57

## D

- data system control 30
- dead volume, transfer tubing 119
- device drivers
  - compatibility 34
  - ordering 127
- diagnostics
  - description 101
  - error messages (table) 102
  - power up 101

## E

- electromagnetic compatibility [iii](#)
- error log
  - ChromQuest data system [105](#)
  - error messages (table) [102](#)
  - Xcalibur data system [104](#)
- errors, common operator [117](#)
- Ethernet cables [39](#)
- Ethernet switch, connecting [39](#)
- external wash, description [30](#)

## F

- fatal error [101](#)
- FCC compliance [iii](#)
- firmware
  - downloading, hardware connections for [130](#)
  - files [129](#)
- fittings
  - injection port [11](#)
  - needle assembly [6](#)
  - needle tube assembly [6](#)
  - sample loop [48](#)
  - syringe valve [41](#)
  - transfer tubing [62](#), [137](#)
  - wash tubing [41](#)
  - waste tubing [62](#), [137](#)
- fixed loop injection, description [19](#)
- flush bottle. *See* wash bottle
- flush solvent
  - effect on no waste injections [17](#)
  - replacing the inlet filter [69](#)
- front panel LEDs
  - names of [16](#)
- full loop injection, description [19](#)
- fuses
  - replacing [96](#)
  - schematic [96](#)

## G

- Gradient Start signal [28](#)

## H

- hardware components, legacy [139](#)
- heat exchanger
  - clearing a plug [94](#)
  - description [15](#)
  - original [139](#)
- heavy object, lifting and carrying [xx](#)
- Help, data system [xvii](#)

- high-pressure tubing [44](#)
- homing
  - syringe position [81](#)
  - XYZ arm position [5](#), [89](#)

## I

- Injection Out signal [29](#)
- injection valve
  - description [12](#)
  - replacing rotor seal (Rheodyne) [135](#)
  - rotor seal (Valco), replacing [61](#)
  - troubleshooting [114](#)
- injections
  - modes [17](#)
  - precision of [17](#), [73](#)
  - sequence of events during [20](#)
  - volume errors [118](#)
- installation
  - autosampler, positioning [35](#)
  - changing the sample loop [48](#)
  - checklist [34](#)
  - turning on the power [46](#)
  - wash bottle, connecting [41](#)
- internal flush, description [30](#)

## K

- kits
  - Accela Accessory [126](#)
  - Accela System [127](#)

## L

- lead screw, lubricating [73](#)
- leaks, injection valve [61](#), [137](#)
- legacy hardware components [139](#)
- lifting and carrying the autosampler [xx](#)
- linear range of no waste injections [17](#)
- loading trays [50](#)

## M

- Maintenance page, ChromQuest data system [98](#)
- maintenance procedures
  - flush solvent inlet filter, replacing [69](#)
  - fuses, replacing [96](#)
  - heat exchanger, clearing blockage in [94](#)
  - injection system blockage, troubleshooting [77](#)
  - lead screw, lubricating [73](#)
  - plugged needle, clearing [77](#)
  - rotor (Valco), replacing [61](#)
  - schedule [60](#)
  - syringe drive assembly, mounting [75](#)

maintenance procedures (continued)  
   syringe, changing 91  
   transfer tube, replacing 69  
 manuals, Accela xvi  
 Matrix Technologies, Web site link 57  
 microplate covers 57  
 microplates  
   description 3  
   recommended 55

## N

needle assembly  
   clearing 77  
   description 6  
 needle port  
   description 11  
   replacing 69  
 needle tubing assembly  
   attachments 35  
   connecting 42  
   description 6  
 no waste injection, description 17

## P

partial loop injection, description 18  
 plugged  
   heat exchanger 94  
   transfer tube, cause of 73  
 plungers, syringe 9, 91  
 power cord 39  
 power indicator 46  
 precision, injection-to-injection  
   no waste injection mode 17  
   partial loop injection mode 18  
   troubleshooting 115  
   with an overtightened transfer tube 73  
 precut stainless steel tubing 44  
 pressure adjustment nut, injection valve 135  
 Pump Ready signal 22  
 PVC cap on the needle tubing assembly 87

## Q

quick reference guides  
   replacing rotor seal (Valco) 137  
   Using the ChromQuest Direct Commands 143  
   Using the Xcalibur Direct Control Commands 141

## R

rear panel connections 36  
 recommended microplate covers 56–57  
 regulatory compliance iii  
 removal position  
   for the needle 51  
   for the syringe 91  
 Rheodyne injection valve 135  
 rotor seal  
   Rheodyne, replacing 135  
   Valco two-sheet replacement guide 137  
   Valco, replacing 61

## S

safety precautions  
   electrical shock 59  
   solvents 69  
 safety standards iii  
 sample carryover. *See* carryover, syringe  
 sample loop  
   changing 48  
   description 15  
 sample trays  
   loading 49  
   loading (caution) 50  
 signals  
   gradient start 28  
   inject out 29  
   pump ready 22  
 solvent lines, connecting  
   high-pressure tubing between the pump and the  
     autosampler 43  
   wash bottle to syringe valve 41  
 stainless steel tubing 44  
 startup sequence, autosampler 46  
 stator (injection valve), scratches (caution) 65  
 syringe  
   changing 91  
   homing 93  
   maximum capacity 19  
   removal position 91  
   standard 9  
   troubleshooting 115  
 syringe rate recommended for no waste injections 17  
 syringe valve  
   description 8  
   testing performance 79  
 system interconnect cable, description 37

**T**

- temperature caution [xxi](#)
- Thermo Foundation Instrument Configuration [120](#)
- transfer tube
  - constriction of [73](#)
  - description [11](#)
  - determining the dead volume of [119](#)
  - replacing [69](#)
- tray temperature control, description [15](#)
- trays, loading [49–50](#)
- troubleshooting
  - band broadening [111](#)
  - baseline drift [109](#)
  - blank injections [69, 118](#)
  - blockage in the injection system [77](#)
  - carryover [111](#)
  - contact closure [37, 113](#)
  - dead volume configuration setting [119](#)
  - Ethernet communication [113](#)
  - general chromatography (table) [108](#)
  - injection valve [114](#)
  - injection volume, lower than expected [117](#)
  - irregular peak shapes [110](#)
  - irreproducible peak areas [112](#)
  - leaks [115](#)
  - needle, plugged [115](#)
  - no peaks [112](#)
  - overview [107](#)
  - peak heights smaller than expected [111](#)
  - precision and accuracy, lack of [112, 115](#)
  - restricted XYZ arm movement [113](#)
  - sensitivity changes [110](#)
  - shifting retention times [109](#)
  - startup [113](#)
  - syringe [115](#)
  - vial caps [114](#)
- tubing
  - behind column oven [15](#)
  - high pressure [44](#)
  - needle [7](#)
  - transfer tube [11](#)
  - wash bottle [41](#)

**U**

- unit ID
  - description [39](#)
  - setting for firmware downloads [130](#)
- URLs
  - customer manuals Web site [xxiv](#)
  - documentation survey for customer feedback [xxiv](#)
  - microplate ordering information [57](#)

**V**

- Valco injection valve [137](#)
- Validation Information dialog box, Xcalibur data system [106](#)
- variable loop injection, description [18](#)
- vial sensor (note) [51](#)
- vials
  - oversized [51](#)
  - recommended [55](#)
- volume
  - excess volume drawn for a partial loop injection [18](#)
  - minimum injection volume for the no waste injection mode [17](#)
  - withdrawn for a full loop injection (table) [19](#)

**W**

- wash bottle
  - allowing to run dry [117](#)
  - assembly [41](#)
  - location [5](#)
- wash station, description [10](#)
- WEEE compliance [v](#)

**X**

- Xcalibur data system
  - control [30](#)
  - direct control commands [141](#)
  - firmware downloads [131](#)
  - maintenance cycles [97](#)
- XYZ arm
  - description [5](#)
  - homing [89](#)
  - moving to the needle removal position [83](#)