



# Sigma 1-16K

## Sigma 1-16K IVD

From serial no. 145758



# Operating Manual

Please retain for later use!



© Copyright by  
Sigma Laborzentrifugen GmbH  
An der Unteren Söse 50  
37520 Osterode am Harz  
Germany

Tel.: +49 (0) 5522 / 5007-0  
Fax: +49 (0) 5522 / 5007-12  
Web: [www.sigma-zentrifugen.de](http://www.sigma-zentrifugen.de)  
E-mail: [info@sigma-zentrifugen.de](mailto:info@sigma-zentrifugen.de)



---

<b>1</b>	<b>General information</b>	<b>9</b>
1.1	Importance of the operating manual	9
1.2	Intended use	9
1.3	Warranty and liability	9
1.4	Copyright	10
1.5	Standards and regulations	10
1.6	Scope of supply	10
<b>2</b>	<b>Layout and mode of operation</b>	<b>11</b>
2.1	Layout of the centrifuge	11
2.1.1	Functional and operating elements	11
2.1.2	Name plate	12
2.1.3	F-gases label	13
2.2	Mode of operation	14
2.2.1	Centrifugation principle	14
2.2.2	Area of application	14
2.2.2.1	Speed, radius, and relative centrifugal force	15
2.2.2.2	Density	15
<b>3</b>	<b>Safety</b>	<b>16</b>
3.1	Marking of the unit	16
3.2	Explanation of the symbols and notes	17
3.3	Responsibility of the operator	18
3.4	Safety of products with MD and IVD mark (medical devices)	19
3.5	Requirements concerning the personnel	20
3.6	Informal safety instructions	21
3.7	Safety instructions	22
3.7.1	Electrical safety	22
3.7.2	Mechanical safety	23
3.7.3	Fire prevention	23
3.7.4	Chemical and biological safety	24
3.7.5	Safety instructions for centrifugation	24
3.7.6	Resistance of plastics	25
3.7.7	Safety of rotors and accessories	25
3.7.7.1	Service life (for centrifuges according to Machinery Directive)	25
3.7.7.2	Service life (for centrifuges according to the IVD regulation)	26
3.8	Safety devices	27
3.8.1	Lid lock device	27
3.8.2	Standstill monitoring system	27
3.8.3	System check	27
3.8.4	Earth conductor check	27
3.8.5	Temperature monitoring system	27
3.9	Measures in the event of hazards and accidents	28
3.10	Remaining hazards	28
<b>4</b>	<b>Storage and transport</b>	<b>29</b>

---

## Table of contents

---

4.1	Dimensions and weight.....	29
4.2	Storage conditions .....	29
4.3	Notes on transport .....	29
4.4	Packaging.....	30
4.5	Transport safety device.....	30
<b>5</b>	<b>Set-up and connection .....</b>	<b>31</b>
5.1	Installation site .....	31
5.2	Power supply .....	31
5.2.1	Type of connection .....	31
5.2.2	Customer-provided fuses.....	32
<b>6</b>	<b>Using the centrifuge .....</b>	<b>33</b>
6.1	Initial start-up .....	33
6.2	Switching the centrifuge on .....	33
6.2.1	Opening and closing the lid.....	33
6.2.2	Installation of rotors and accessories .....	34
6.2.2.1	Installation of a rotor .....	34
6.2.2.2	Installation of a microhaematocrit rotor .....	34
6.2.2.3	Installation of accessories .....	36
6.2.2.4	Vessels .....	36
6.3	Control System "Spincontrol Basic" .....	37
6.3.1	User interface .....	37
6.3.2	Display.....	37
6.3.3	Starting a centrifugation run.....	38
6.3.4	Interrupting a centrifugation run .....	38
6.3.5	Interrupting a deceleration process .....	38
6.3.6	Speed / Relative centrifugal force (RCF).....	38
6.3.6.1	Changing the speed/RCF value during centrifugation .....	38
6.3.7	Runtime .....	39
6.3.7.1	Changing the runtime during centrifugation.....	39
6.3.7.2	Short run.....	39
6.3.7.3	Continuous run.....	40
6.3.8	Temperature .....	40
6.3.8.1	Precooling program "Precool" .....	40
6.3.9	Softstart and softstop function .....	41
6.3.10	Rotor selection.....	42
6.3.11	Button lock.....	42
6.3.12	Eco mode .....	43
6.3.13	Program.....	45
6.3.13.1	Saving the current settings.....	45
6.3.13.2	Calling up stored programs .....	45
6.4	Switching the centrifuge off .....	45
<b>7</b>	<b>Malfunctions and error correction.....</b>	<b>46</b>
7.1	General malfunctions.....	46
7.1.1	Emergency lid release .....	47

**Table of contents**

---

7.2	Table of error codes.....	48
7.3	Service contact .....	49
<b>8</b>	<b>Maintenance and service.....</b>	<b>50</b>
8.1	General.....	50
8.1.1	Cleaning .....	51
8.1.1.1	Cleaning of the centrifuge .....	51
8.1.1.2	Cleaning of rotors.....	52
8.1.1.3	Cleaning of adapters .....	52
8.1.2	Disinfection .....	53
8.1.2.1	Disinfection of the centrifuge .....	53
8.1.2.2	Disinfection of rotors .....	53
8.1.2.3	Disinfection of adapters.....	54
8.1.1	Autoclaving .....	55
8.2	Maintenance tasks.....	56
8.2.1	Maintenance of the centrifuge.....	56
8.2.1.1	Condenser (Only with air-cooled refrigeration system) .....	56
8.2.2	Maintenance of rotors and adapters .....	57
8.2.2.1	Plastic accessories .....	58
8.2.3	Broken glass.....	58
8.3	Maintenance and service .....	59
8.4	Return of defective centrifuges or parts .....	60
<b>9</b>	<b>Disposal.....</b>	<b>62</b>
9.1	Disposal of the centrifuge .....	62
9.2	Disposal of the packaging.....	62
<b>10</b>	<b>Technical data.....</b>	<b>63</b>
10.1	Ambient conditions .....	64
10.2	Technical documentation .....	64
<b>11</b>	<b>Appendix .....</b>	<b>65</b>
11.1	Range of accessories .....	65
11.1.1	Rotor radii.....	65
11.2	Table of the service life of rotors and accessories.....	66
11.3	Resistance data .....	67
11.4	EC declaration of conformity .....	71
11.5	Declaration of conformity – China RoHS 2.....	75
<b>12</b>	<b>Index .....</b>	<b>77</b>

**Table of contents**

---

## 1 General information

### 1.1 Importance of the operating manual

A fundamental requirement for the safe and trouble-free operation of the centrifuge is to be familiar with the fundamental safety instructions and all possible hazards.

The operating manual includes important information concerning the safe operation of the centrifuge.

This operating manual and, in particular, the notes on safety and hazards must be observed by all persons operating the centrifuge.

In addition, the local rules and regulations for the prevention of accidents must be complied with.

### 1.2 Intended use

The laboratory centrifuge is suitable for the separation of constituents of different densities in mixtures with a maximum density of 1.2 g/cm<sup>3</sup>.

The laboratory centrifuge that is marked with IVD is intended for human biological samples, including donated blood and tissue, in conjunction with diagnostic in-vitro applications. This means that it is a medical product in accordance with Regulation (EU) 2017/746 on in vitro diagnostics.

Only trained, specialised personnel are authorised to use the centrifuge in closed laboratories.

The intended use also includes:

- observation of all of the notes and instructions that are included in the operating manual and
- compliance with the inspection and maintenance instructions.

**Sigma Laborzentrifugen GmbH cannot be held liable for:**

- damage resulting from the improper use of the centrifuge not in line with its intended purpose,
- faulty results that are due to the incorrect or faulty procedures of the user.

### 1.3 Warranty and liability

The warranty and liability are subject to our "General Conditions" that were distributed to the operator upon the conclusion of the contract.

Warranty and liability claims are excluded if they are due to:

- improper use.
- non-compliance with the safety instructions and hazard warnings in the operating manual.
- improper installation, start-up, operation, or maintenance of the centrifuge.

## 1 General information

---

### 1.4 Copyright

The copyright concerning the operating manual remains with Sigma Laborzentrifugen GmbH.

The operating manual is solely intended for the operator and their personnel. It includes instructions and information that must not be

- duplicated,
- distributed, or
- communicated in any other way.

Non-compliance may be prosecuted under criminal law.

### 1.5 Standards and regulations

These operating instructions have been created in accordance with the relevant European standards and regulations (see chapter 11.4 - "EC declaration of conformity").

### 1.6 Scope of supply

**The centrifuge comprises:**

- 1 power cord with IEC C13 connector
- 1 socket wrench, size 4 (rotor) Part no. 930 050
- 1 socket wrench, size 6 (emergency release) Part no. 930 056

**Documentation**

Operating manual incl. EC declaration of conformity  
(see chapter 11.4 - "EC declaration of conformity")

**Accessories**

According to your order, our order confirmation, and your delivery note.

## 2 Layout and mode of operation

### 2.1 Layout of the centrifuge

#### 2.1.1 Functional and operating elements

- 1 Lid
- 2 Display
- 3 User interface  
(see chapter 6.3.1 -  
"User interface")



*Fig. 1: Total view of the centrifuge*

- 4 Mains power switch
- 5 Mains power input
- 6 Name plate  
(see chapter 2.1.2 -  
"Name plate")



*Fig. 2: Rear view of the centrifuge (example)*

## 2 Layout and mode of operation

### 2.1.2 Name plate

- 1 Manufacturer
- 2 Power consumption
- 3 Max. speed
- 4 Max. kinetic energy
- 5 Product name
- 6 Part number
- 7 Serial number
- 8 Nominal voltage
- 9 Type
- 10 CE mark in compliance with the directive 2006/42/EC
- 11 Symbol for special disposal (see chapter 9 - "Disposal")
- 12 IVD mark (if applicable)
- 13 Date of manufacture
- 14 Consult operating manual
- 15 Max. permissible density
- 16 Refrigerant data

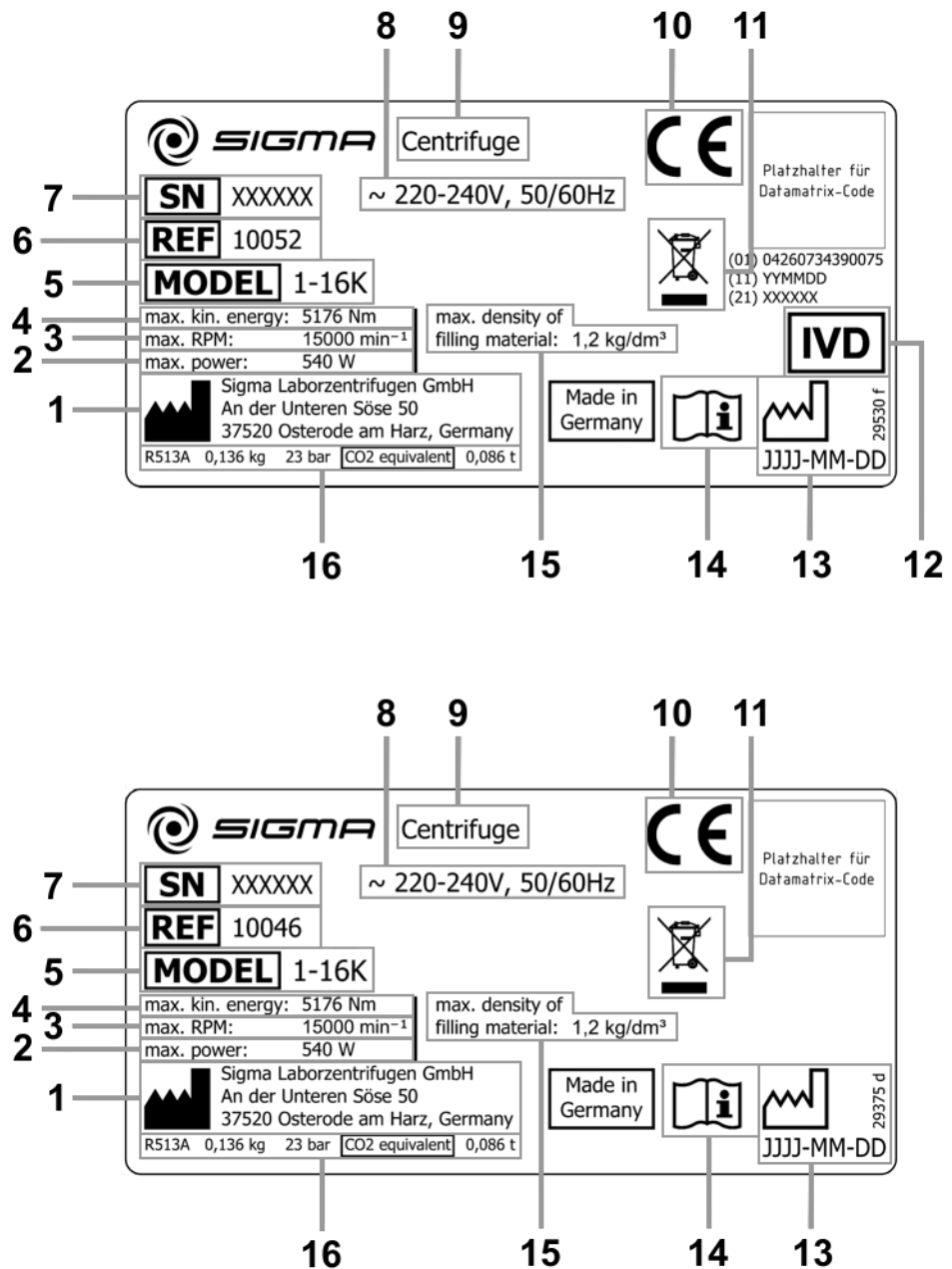

Fig. 3: Examples of name plates

**2.1.3 F-gases label**

<p><b>DE</b> Enthält fluorierte Treibhausgase in einer hermetisch geschlossenen Kälteanlage</p> <p><b>EN</b> Contains fluorinated greenhouse gases in a hermetically sealed refrigeration system</p> <p><b>FR</b> Contient des gaz à effet de serre fluorés dans un équipement de réfrigération hermétiquement scellé</p> <p><b>SV</b> Innehåller fluorerade växthusgaser i en hermetiskt sluten kylanläggning</p> <p><b>ES</b> Contiene gases fluorados de efecto invernadero en un sistema de refrigeración herméticamente cerrado</p> <p><b>NL</b> Bevat gefluoreerde broeikasgassen in een hermetisch gesloten koelinstallatie</p> <p><b>DA</b> Indeholder fluorerede drivhusgasser i et hermetisk lukket kølesystem</p> <p><b>PL</b> Zawiera fluorowane gazy cieplarniane w hermetycznym zamkniętym urządzeniu chłodniczym</p> <p><b>GA</b> Cuidisítear gáis cheaptha teasa fhluairínithe i gcóras cuisniúcháin atá séalaithe go heirméiteach anseo</p> <p><b>IT</b> Contiene gas serra fluorurati in impianto di raffreddamento sigillato ermeticamente</p> <p><b>SL</b> Vsebuje fluorirane toplogredne pline v hermetično zaprtem hladilnem sistemu</p> <p><b>PT</b> Contém gases fluorados com efeito de estufa num sistema de refrigeração herméticamente fechado</p> <p><b>EL</b> Περιέχει φθοριούχα αέρια θερμοκηπίου σε ερμητικά κλειστό σύστημα ψύξης</p> <p><b>BG</b> Съдържа флуорирани парникови газове в херметически затворена хладилна система</p> <p><b>HU</b> Fluorozott üvegházhatású gázokat tartalmaz, hermetikusan zárt hűtőrendszerben</p> <p><b>FI</b> Sisältää fluorattuja kasvihuonekaasuja ilmatiivisti suljetussa jäähdytysjärjestelmässä</p> <p><b>CS</b> Obsahuje fluorované skleníkové plyny v hermeticky uzavřeném chladicím systému</p> <p><b>SK</b> Obsahuje fluórované skleníkové plyny v hermeticky uzavretom chladiacom systéme</p> <p><b>RO</b> Conține gaze fluorurate cu efect de seră într-un sistem de refrigerare etanșat ermetic</p> <p><b>HR</b> Sadržava fluorirane stakleničke plinove u hermetički zatvorenoj rashladnoj opremi</p> <p><b>ET</b> Sisaldab fluoritud kasvihuonegaase hermeetiliselt suletud jahutussüsteemis</p> <p><b>LV</b> Satur fluorētas siltumnīcefekta gāzes hermētiski noslēgtā dzesēšanas sistēmā</p> <p><b>LT</b> Hermetiškai užsandarintoje šaldymo sistemoje yra fluorintų šiltnamio efektą sukeliančių dujų</p> <p><b>MT</b> Fih gassijiet fluworurati b'effett ta' serra f'sistema ta' tkessih issigillata ermetikament</p> <p><b>NO</b> Inneholder fluorinerte drivhusgasser i et hermetisk lukket kjølesystem</p> <p>R452A GWP: 2140 R513A GWP: 630</p> <p>(EU) 2024/2729; 2028-DEC-31</p>	31402
--	-------

Fig. 4: F-gases label in compliance with the implementation regulation (EU) 2024/2729

## 2 Layout and mode of operation

---

### 2.2 Mode of operation

#### 2.2.1 Centrifugation principle

Centrifugation is a process for the separation of heterogeneous mixtures of substances (suspensions, emulsions, or gas mixtures) into their components. The mixture of substances, which rotates on a circular path, is subject to centripetal acceleration that is several times greater than the gravitational acceleration.

Centrifuges use the mass inertia inside the rotor chamber for separating the substances. Due to their higher inertia, particles or media with a higher density travel outwards. In doing so, they displace the components with a lower density, which in turn travel towards the centre.

The centripetal acceleration of an object inside a centrifuge, as the effect of centripetal force, depends on the distance between the object and the axis of rotation as well as on the angular velocity. It increases linearly as a function of the distance with regard to the axis of rotation and quadratically as a function of the angular velocity. The bigger the radius in the rotor chamber is and the higher the speed is, the higher the centripetal acceleration is. However, the forces acting on the rotor also increase.

#### 2.2.2 Area of application

Depending on the area of application of the centrifuge and also on the particle size, solids content, and volume throughput of the mixture of substances that is to be centrifuged, there are different types of centrifuges.

The areas of application go from household use as a salad spinner or honey separator up to specialised technical applications in the clinical, biological, or biochemical context:

- For numerous clinical examinations, cellular material must be separated from the liquid to be analysed. The normal separation process can be sped up considerably by using laboratory centrifuges.
- In the metal-working industry, centrifuges are used for separating oil from metal cuttings. Dairies use centrifuges in order to separate cow's milk into cream and low-fat milk.
- Particularly big centrifuges are used in the sugar industry for separating the syrup from the crystalline sugar.
- Ultracentrifuges are predominantly used in biology and biochemistry in order to isolate particles, e.g. viruses. They are specifically designed for high speeds up to 500,000 rpm. The rotor moves in a vacuum in order to avoid air friction.

**2.2.2.1 Speed, radius, and relative centrifugal force**

The acceleration  $g$ , which the samples are subject to, can be increased by increasing the radius in the rotor chamber and by increasing the speed. These three parameters are interdependent and linked with each other via the following formula:

$$\text{Relative centrifugal force RCF} = 11.18 \times 10^{-6} \times r \times n^2$$

$r$  = radius in cm

$n$  = speed in rpm

RCF without any dimension

If two values are entered, the third value is determined by way of the stated formula. If, afterwards, the speed or the radius is changed, the resulting relative centrifugal force will be recalculated automatically by the control unit. If the RCF is changed, the speed will be adapted while the specified radius is maintained.

The speed-gravitational-field-diagram provides an overview of the relationship between speed, radius, and RCF.

**2.2.2.2 Density**

The laboratory centrifuge is suitable for the separation of constituents of different densities in mixtures with a maximum density of  $1.2 \text{ g/cm}^3$ . All information concerning the speed of rotors and accessories refers to liquids with a density corresponding to this specification. If the density is above this value, the maximum permissible speed of the centrifuge must be reduced based on the following formula:

$$n = n_{max} \times \sqrt{(1.2/\rho)}$$















$\rho$  = density in  $\text{g/cm}^3$

### 3 Safety

## 3 Safety

### 3.1 Marking of the unit

The following symbols are used on this centrifuge:

	On (Power)		Arrow indicating the direction of rotation
	Off (Power)		4°C Guarantee
	Name plate (see chapter 2.1.2 - "Name plate")		F-gases label in compliance with the implementation regulation (EU) 2024/2729
	Do not dispose as part of domestic waste		CE mark in compliance with the directive 2006/42/EC
	Medical product in accordance with the regulation (EU) 2017/746		Consult operating manual
	RCM mark (only for Australia)		NRTL mark (only for the USA and Canada)
	California Proposition 65 mark (only for the USA)		China RoHS 2 mark (only for China)

  
NOTE

Safety indications on the centrifuge must be kept readable at all times. If necessary, they must be replaced.

  
NOTE

The marking varies depending on the version and country of destination of the centrifuge.

### 3.2 Explanation of the symbols and notes

In this operating manual, the following names and symbols to indicate hazards are used:



**DANGER**

This symbol stands for a **direct** hazard to the life and health of persons.

Non-observance of these symbols **causes** serious health problems up to life-endangering injuries.



**DANGER**

This symbol stands for a **direct** hazard to the life and health of persons due to electrical voltage.

Non-observance of these symbols **causes** serious health problems up to life-endangering injuries.



**WARNING**

This symbol stands for a **potential** hazard to the life and health of persons.

Non-observance of these symbols **can** cause serious health problems up to life-endangering injuries.



**CAUTION**

This symbol indicates a potentially hazardous situation.

Non-observance of these notes can cause minor injuries or damage to property.



**NOTE**

This symbol indicates important information.

### 3 Safety

---

#### 3.3 Responsibility of the operator

The operator undertakes to only authorise trained specialised personnel to work on the centrifuge (see chapter 3.5 - "Requirements concerning the personnel", section "Operating personnel").

The areas of responsibility of the personnel concerning the operation, maintenance and care of the unit must be clearly defined.

The safety-conscious work of the personnel in compliance with the operating manual, relevant EC health and safety directives and national laws concerning health and safety and the prevention of accidents must be checked at regular intervals (e.g. every month).

Under the international rules for health and safety at work (only in Germany: DGUV FBRCI 025), the operator is obliged to:

- take measures in order to prevent danger to life or health during work.
- ensure that the centrifuges are used properly and entirely as intended (see chapter 1.2 - "Intended use").
- take protective measures against fire and explosion when working with hazardous substances.
- take measures for the safe opening of the centrifuges.

The operator must perform a risk assessment concerning potential accidents in connection with the centrifuge and take design-related countermeasures, if necessary.

The operator must inform users that any serious event which either directly or indirectly had, could have had or could have one of the following consequences must be reported to the manufacturer or competent authority:

- a) death of a patient, user or other person
- b) the temporary or permanent degradation of the health of a patient, user or other person
- c) a serious risk to public health

The centrifuge must be maintained at regular intervals (see chapter 8 - "Maintenance and service").

Any parts or components that are not in perfect working order must be replaced without delay.

### 3.4 Safety of products with MD and IVD mark (medical devices)

Centrifuges labelled as medical devices (MD) in accordance with regulation (EU) 2017/745 and those labelled as in-vitro diagnostic medical devices (IVD) in accordance with regulation (EU) 2017/746 are exclusively intended for use by specialist users in their respective field of work.

#### **Serious incident (definition)**

*Incident* means any malfunction or deterioration in the characteristics or performance of an MD or IVD device which is made available on the market for an intended use as defined by the manufacturer, including user errors due to ergonomic features as well as any inadequacy in the information supplied by the manufacturer or any undesirable side effects.

*Serious incident* means any incident that directly or indirectly led, might have led or might lead to any of the following:

- a) the death of a patient, user or other person,
- b) the temporary or permanent serious degradation of a patient's, user's or other person's state of health,
- c) a serious public health threat.

#### **Reporting of a serious incident to the manufacturer and the competent authorities within the EU**

A reportable serious incident is an incident that has a causal relationship with an MD or IVD product or where such a causal relationship is reasonably possible. Such an incident must be reported without delay to the manufacturer, Sigma Laborzentrifugen GmbH or the competent national authorities within the EU. If the report is issued to the manufacturer or their authorised representative, they must fulfil their reporting obligation to the authorities. EUDAMED provides forms for the electronic reporting of incidents by manufacturers and authorised representatives via MIR (Manufacturer Incident Report) or by users, operators and distributors (User Report).

Authorised distributors, vendors and service providers are required by law to cooperate with the manufacturer in order to ensure the safety of medical devices. Non-compliance may result in substantial fines and penalties.

To report a serious incident to the manufacturer:

1. Please complete the "Incident reporting to the manufacturer" form in full.
2. Send the form to [support@sigma-zentrifugen.de](mailto:support@sigma-zentrifugen.de)

### 3 Safety

The form for reporting an IVD incident to the manufacturer is available on our website.

[www.sigma-zentrifugen.de](http://www.sigma-zentrifugen.de) → [Service] → [Overhaul and repair]

#### Scan QR-Code

If you have any questions to this subject, please contact our service department:



### 3.5 Requirements concerning the personnel



**DANGER**

#### Risk of injury if the personnel are not sufficiently qualified

If unqualified personnel perform work on the centrifuge or are present in the danger zone of the centrifuge, hazards result that can cause serious injuries and considerable damage to property.

- Ensure that all the tasks are performed by personnel with the corresponding qualifications.
- Ensure that unqualified personnel stay clear of the danger zones.



**DANGER**

#### Risk of fatal injury to unauthorised persons due to hazards in the danger zone or work area

Unauthorised persons who do not fulfil the requirements described herein are not aware of the hazards in the work area. This is why there is a risk of serious or even fatal injuries for unauthorised persons.

- Ensure that unauthorised persons stay clear of the danger zone and work area.
- If in doubt, address these persons and instruct them to leave the danger zone and work area.
- Interrupt any running work if unauthorised persons are present in the danger zone or work area.

This manual uses the following personnel qualifications for various areas of activity:

#### Qualified electrician

Due to their special training, knowledge, experience and familiarity with the relevant standards and regulations, qualified electricians are in the position to perform work on electrical systems and to autonomously identify and prevent possible hazards.

Qualified electricians have been specifically trained for the environment in which they work and they are familiar with all the relevant standards and regulations.

Qualified electricians must fulfil the requirements as set out in the applicable legal provisions concerning the prevention of accidents.

**Specialised personnel**

Due to their special training, knowledge, experience and familiarity with the relevant regulations, specialised personnel are in the position to perform any tasks assigned to them and to autonomously identify and prevent possible hazards.

**Operating personnel**

Only trained, specialised personnel are authorised to operate the unit. The persons operating the unit must

- be familiar with the fundamental health, safety, and accident prevention regulations,
- have read and understood this operating manual, in particular the safety sections and warning notes, and confirmed this with their signature,
- have been instructed in the operation and maintenance of this centrifuge.

The operating personnel must ensure that any serious event which either directly or indirectly had, could have had or could have one of the following consequences will be reported to the manufacturer or competent authority:

- a) The death of a patient, user or other person,
- b) the temporary or permanent degradation of the health of a patient, user or other person,
- c) a serious risk to public health.

**3.6 Informal safety instructions**

- This operating manual is a part of the product.
- The operating manual must be kept at the location of use of the centrifuge. Ensure that it is accessible at all times.
- The operating manual must be handed over to any subsequent owner or operator of the centrifuge.
- Any changes, additions or updates received must be added to the operating manual.
- In addition to the operating manual, the general and local rules and regulations concerning the prevention of accidents and the protection of the environment must also be supplied.
- Safety and danger indications on the centrifuge must be kept readable at all times. If necessary, they must be replaced.

### 3 Safety

---

## 3.7 Safety instructions

### 3.7.1 Electrical safety

As protection against electric shock, the centrifuge is equipped with an earthed mains power cable and connector. To ensure the effectiveness of this safety feature, the following must be ensured:



**DANGER**

- Ensure that the wall socket is properly wired and grounded.
- Check that the mains voltage agrees with the nominal voltage listed on the name plate.
- Ensure that the mains power cable is intact prior to using the centrifuge. Damaged or faulty mains power cables must be replaced immediately.
- Do not place vessels containing liquid on the centrifuge lid or within the safety distance of 30 cm around the centrifuge. Spilled liquids may get into the centrifuge and damage electrical or mechanical components.
- Service tasks or repairs of the electrical system for which the housing needs to be removed must only be carried out by authorised specialist personnel.
- Inspect the electrical equipment of the unit regularly. Defects such as loose or burnt cables must be eliminated immediately.
- Following the completion of any type of repair or service, the authorised specialist personnel must perform final inspection and testing in compliance with the relevant standards (see chapter 8.3 - "Maintenance and service").

### 3.7.2 Mechanical safety

In order to ensure the safe operation of the centrifuge, observe the following:



**WARNING**

- Do not open the lid when the rotor is in motion!
- Do not reach into the rotor chamber when the rotor is in motion!
- Do not use the centrifuge if it was installed incorrectly.
- Do not use the centrifuge without panels.
- Do not use the centrifuge if the rotors and inserts show signs of corrosion or other defects.
- Never operate the instrument without a rotor installed.
- Only use the centrifuge with rotors and accessories that have been approved by the manufacturer. In case of doubt, contact the manufacturer (see chapter 7.3 - "Service contact").
- Do not hold your fingers between the lid and the housing when closing the lid. Risk of crushing!
- Defective lid relieving devices could cause the centrifuge lid to fall (contact the service department, if necessary). Risk of crushing!
- Do not hit or move the centrifuge during its operation.
- Do not lean against or rest on the centrifuge during its operation.
- Do not spin any substances that could damage the material of the rotors and buckets of the centrifuge in any way. Highly corrosive substances, for example, damage the material and affect the mechanical strength of the rotors and buckets.
- Stop the centrifuge immediately in the event of a malfunction. Eliminate the malfunction (see chapter 7 - "Malfunctions and error correction") or inform the service department of Sigma Laborzentrifugen GmbH (see chapter 7.3 - "Service contact").
- If the housing becomes damaged, do not use the centrifuge. Contact the service department of Sigma Laborzentrifugen GmbH (see chapter 7.3 - "Service contact").
- Ensure that all repairs are performed only by authorised and specialised personnel.
- Prior to any start-up, check the centrifuge, rotor, and accessories for signs of damage that can be discerned from the outside. Special attention must be paid to all of the rubber parts (e.g. motor cover, lid seal, and adapters) in terms of visible structural changes. Defective parts must be replaced immediately.
- Open the centrifuge when it is not in use so that moisture can evaporate.



**WARNING**

### 3.7.3 Fire prevention



**DANGER**

- Do not spin explosive or inflammable substances.
- Do not use the centrifuge within hazardous locations.

### 3 Safety

#### 3.7.4 Chemical and biological safety

If pathogenic, toxic, or radioactive samples are intended to be used in the centrifuge, it is in the responsibility of the user to ensure that all necessary safety regulations, guidelines, precautions, and practices are adhered to accordingly.



**DANGER**

- Infectious, toxic, pathogenic, and radioactive substances may only be used in special, certified containment systems with a bio-seal in order to prevent the material from being released.
- Take suitable precautions for your own safety if there is a risk of toxic, radioactive, or pathogenic contamination
- Materials that chemically react with each other with a high level of energy are prohibited.



**WARNING**

- Keep informed about local measures to avoid harmful emissions (depending on the substances to be centrifuged).
- Protective clothing is not required for the operation of the centrifuge. The materials to be centrifuged may, however, require special safety measures (e.g. centrifugation of infectious, toxic, radioactive, or pathogenic substances).

#### 3.7.5 Safety instructions for centrifugation

For safe operation, observe the following before starting the centrifuge:



**WARNING**

- Ensure that the centrifuge was set up properly (see chapter 5 - "Set-up and connection").
- Keep a safety range of at least 30 cm free around the centrifuge as well as with regard to walls and other devices.
- Do not store any dangerous goods in the centrifuge area.
- Do not stay in the safety area longer than what is absolutely necessary for the operation of the centrifuge.
- Only use the centrifuge with rotors and accessories that have been approved by the manufacturer. We explicitly warn against the use of equipment of poor quality. Breaking glass or bursting vessels can cause dangerous imbalances at high speeds.
- Ensure that the rotor and buckets are correctly fitted (see chapter 6.2.2.1 - "Installation of a rotor").
- Observe the instructions on the installation of accessories (see chapter 6.2.2.3 - "Installation of accessories").
- The rotor must be loaded in a rotationally symmetrical manner at equal weights.
- If liquids with a density  $> 1.2 \text{ g/cm}^3$  are used, reduce the speed (see chapter 2.2.2.2 - "Density").
- Do not use the centrifuge if the rotor is loaded asymmetrically.
- Do not use the centrifuge with tubes that are excessively long.

### 3.7.6 Resistance of plastics

Chemical influences have a strong effect on the polymeric chains of plastics, and, therefore, on their physical properties. Plastic parts can be damaged if solvents, acids, or alkaline solutions are used.



- Refer to the resistance data (see chapter 11.3 - "Resistance data")!

### 3.7.7 Safety of rotors and accessories

#### 3.7.7.1 Service life (for centrifuges according to Machinery Directive)

The rotors and accessories have a limited service life.



- Perform regular checks (at least once per month) for safety reasons!
- Pay special attention to changes, such as corrosion, cracks, material abrasion, etc.

- After 10 years, they must be inspected by the manufacturer.
- After 50,000 cycles, the rotor must be scrapped for reasons of safety.
- If other data concerning the service life are engraved on the rotor or bucket, these data shall apply accordingly. For example, a bucket with the engraving "max. cycles = 15000" has a service life of 15,000 cycles, and a rotor with the engraving "Exp. date 01/27" must be scrapped in January 2027 at the latest (see figure).
- If a specification concerning the maximum number of cycles **and** a specification concerning the service life (i.e. a date) are provided, the specification that occurs first shall apply.



Fig. 5: Different service life – engraving on the bucket/rotor



- Refer to the table of the service life of rotors and accessories (see chapter 11.2 - "Table of the service life of rotors and accessories ")!

### 3 Safety

#### 3.7.7.2 Service life (for centrifuges according to the IVD regulation)

##### Centrifuge

The service life of the centrifuge depends on several factors, e.g. the type and frequency of use, the area of application and the performance of service and maintenance tasks.

- The centrifuge has an expected service life of 10 years if all of the specified maintenance intervals are observed and all of the necessary maintenance tasks are performed without delay (see chapter 8.3 - "Maintenance and service"). Non-compliance will shorten the service life of the centrifuge accordingly.
- The availability of spare parts can no longer be guaranteed after 10 years from the date of manufacture of the centrifuge.

##### Rotors and accessories

The rotors and accessories have a limited service life.



**WARNING**

- Perform regular checks (at least once per month) for safety reasons!
- Pay special attention to changes, such as corrosion, cracks, material abrasion, etc.

- The rotors and accessories must be put out of service after 10 years. Any use after this period may be permissible in individual cases after an inspection performed by the manufacturer.
- After 50,000 cycles, the rotor must be scrapped for reasons of safety.
- If other data concerning the service life are engraved on the rotor or bucket, these data shall apply accordingly. For example, a bucket with the engraving "max. cycles = 10,000" has a service life of 10,000 cycles, and a rotor with the engraving "Exp. date 01/27" must be scrapped in January 2027 at the latest (see figure below).
- If a specification concerning the maximum number of cycles **and** a specification concerning the service life (i.e. a date) are provided, the specification that occurs first shall apply.



Fig. 6: Different service life – engraving on the bucket/rotor

**i**  
**NOTE**

- Refer to the table of the service life of rotors and accessories (see chapter 11.2 - "Table of the service life of rotors and accessories ")!

## **3.8 Safety devices**

### **3.8.1 Lid lock device**

The centrifuge can only be started when the lid is properly closed. The electrical lock must be locked. The lid can only be opened when the rotor has stopped. If the lid is opened by way of the emergency release system during operation, the centrifuge will immediately switch off and decelerate brakeless. If the lid is open, the drive is completely separated from the mains power supply, i.e. the centrifuge cannot be started (see chapter 7.1.1 - "Emergency lid release").

### **3.8.2 Standstill monitoring system**

Opening of the centrifuge lid is only possible if the rotor is at a standstill. This standstill is checked by the microprocessor.

### **3.8.3 System check**

An internal system check monitors the data transfer and sensor signals with regard to plausibility. The system continuously performs a self-check and identifies malfunctions. Malfunctions are indicated by error messages with a number in the speed/rcf display (see chapter 7.2 - "Table of error codes").

### **3.8.4 Earth conductor check**

An earth conductor check can be carried out by authorised and specialised personnel using a suitable measuring instrument. Please contact the Sigma service department (see chapter 7.3 - "Service contact").

### **3.8.5 Temperature monitoring system**

If the temperature inside the rotor chamber rises above +50°C, the drive system will be switched off automatically. The centrifuge cannot be restarted until it has cooled.

### 3 Safety

---

#### 3.9 Measures in the event of hazards and accidents



**DANGER**

- If an emergency arises, switch off the centrifuge immediately!
- If in doubt, call the emergency doctor!

#### 3.10 Remaining hazards

The centrifuge was built in accordance with the state of the art and in compliance with the generally recognized safety rules. However, danger to life and limb of the operator, or of third parties, or impairments of the unit or other material assets cannot be completely excluded when the unit is being used.

- Use the unit only for the purpose that it was originally intended for (see chapter 1.2 - "Intended use").
- Use the unit only if it is in a perfect running state.
- Immediately eliminate any problems that can affect safety.

## 4 Storage and transport

### 4.1 Dimensions and weight

	1-16K, 1-16K IVD
Height:	291 mm
Height with open lid:	547 mm
Width:	310 mm
Depth:	660 mm
Weight:	34 kg

### 4.2 Storage conditions

The centrifuge can be stored in its original packaging for up to a year.

- Store the centrifuge only in dry rooms.
- The permissible storage temperature is between -20°C and +60°C.
- If you would like to store it for more than one year, or if you intend to ship it overseas, please contact the manufacturer.

### 4.3 Notes on transport

- When lifting the centrifuge, always reach under the centrifuge from the side.



**CAUTION**

The centrifuge weighs approx. 34 kg!

- For transport use suitable packaging and, if at all possible, the original packaging (see chapter 4.4 - "Packaging").

## 4 Storage and transport

---

### 4.4 Packaging

The centrifuge is packaged in a cardboard box.

- Open the box.
- Take out the box containing the accessories.
- Lift the centrifuge with both foam cushions out of the cardboard box.  
When lifting the centrifuge, always reach under the centrifuge from the side.



**CAUTION**

The centrifuge weighs approx. 34 kg!

- Retain the packaging for any possible future transport of the centrifuge.

### 4.5 Transport safety device

The centrifuge is not equipped with a transport safety device.

## 5 Set-up and connection

### 5.1 Installation site

Operate the centrifuge only in closed and dry rooms.

All the energy supplied to the centrifuge is converted into heat and emitted to the ambient air.

- Ensure sufficient ventilation.
- Keep a safety range of at least 30 cm free around the centrifuge as well as with regard to walls or other devices so that the vents in the machine remain unobstructed and fully effective.
- Do not subject the centrifuge to thermal stress, e.g. by positioning it near heat generators.
- Avoid direct sunlight (UV radiation).
- The table must be stable and have a solid, even surface.
- Attention: During transport from cold to warmer places, condensational water will collect inside the centrifuge. It is important to allow sufficient time for drying (min. 24 h) before the centrifuge can be used again.

### 5.2 Power supply

#### 5.2.1 Type of connection



**DANGER**

The operating voltage on the name plate must correspond to the local supply voltage!



**CAUTION**

The mains power plug is an isolating device which is why it must be accessible at all times.

Sigma centrifuges are units of protection class I. The centrifuges of this model series have a three-wire power cord with an IEC C13 connector.



**NOTE**

The removable power cord must not be longer than 3 m!  
The power cord must not be replaced with a power cord of inadequate rating!

## 5 Set-up and connection

---

### 5.2.2 Customer-provided fuses

Typically, the centrifuge must be protected with 16 Amp B fuses that are to be provided by the customer.



To ensure safe disconnection in the event of a fault, an AC/DC-sensitive RCD (residual current device) must be integrated in the wiring system of the building.

## 6 Using the centrifuge

### 6.1 Initial start-up



**DANGER**

- Before the initial start-up, please ensure that your centrifuge is properly set up and installed (see chapter 5 - "Set-up and connection").

### 6.2 Switching the centrifuge on

- Press the mains power switch.  
The display then illuminates. The centrifuge is ready for operation.

#### 6.2.1 Opening and closing the lid

The lid can be opened if the centrifuge is at a standstill.

- Press the lid key in order to open the lid.

The centrifuge cannot be started if the lid is opened.

- To close, press with both hands slightly on the lid until the lid lock is locked.



**WARNING**

Do not place your fingers between the lid and the housing when closing the lid. Risk of crushing!

## 6 Using the centrifuge

### 6.2.2 Installation of rotors and accessories

#### 6.2.2.1 Installation of a rotor

- Open the centrifuge lid by pressing the lid key.
- Loosen the rotor tie-down screw by turning it anti-clockwise, but do not remove it.
- Lower the rotor with its central bore straight down onto the motor shaft.
- Tighten the rotor tie-down screw clockwise with the supplied rotor wrench with 3 Nm. In doing so, hold the rotor at its outer rim.
- Follow the safety instructions and hazard warnings (see chapter 3 - "Safety")!



**WARNING**

Loosen and tighten the rotor tie-down screw at regular intervals (depending on the frequency of use) to ensure a proper connection between the rotor holder and the motor shaft.



**NOTE**

Rotors can be used without a cover. This leads, however, to higher levels of noise and temperatures when running.

#### Removing a rotor

- Loosen the rotor tie-down screw by turning it anti-clockwise and remove the rotor.

#### 6.2.2.2 Installation of a microhaematocrit rotor



Fig. 7: Microhaematokrit rotor (part no. 11024) with reader (part no. 17029)

- Open the centrifuge lid by pressing the lid key.
- Loosen the rotor tie-down screw by turning it anti-clockwise, but do not remove it.

## 6 Using the centrifuge

---

- Lower the rotor with its central bore straight down onto the motor shaft.
- Tighten the rotor tie-down screw clockwise with 3 Nm using the supplied rotor wrench. In doing so, hold the microhaematocrit rotor with one hand and tilt it slightly in order to prevent the motor shaft from slipping through.
- Follow the safety instructions and hazard warnings (see chapter 3 - "Safety")!

### Operation

- Fill the capillary tubes with blood and seal them at one end with putty or by fusion.
- Place the capillary tubes into the recesses of the rotor with the sealed end against the rubber ring. Ensure that the capillary tubes fit tightly against the rubber ring. The opposite places must be loaded.
- Put the rotor cover on and lock it.
- Close the centrifuge lid.
- Enter the following parameters: speed 14,000 rpm, gravitational field RCF max. 18,626 x g, time approx. 5 min.
- Start the centrifuge.
- Open the centrifuge lid when the rotor has stopped.
- Unlock the rotor cover and lift it off.

### Evaluation

- Put the reader onto the rotor.
- Turn the reader and perform a fine adjustment with the aid of the central eccentric mechanism in order to localize the O-point and the maximum liquid point in the capillary tubes. You can now read the percentage value.
- Remove the capillary tubes. Some of the tubes can also be evaluated with the reader outside of the rotor (see the instructions for use on the back of the reader).

## 6 Using the centrifuge

### 6.2.2.3 Installation of accessories

- Only use tubes that are suitable for the rotor.
- Always load the axial symmetrical inserts of the rotors with the same accessories and fill to avoid imbalance.

#### Centrifugation with low capacity

- Install the tubes axial symmetrical so that the rotor is loaded evenly.
- It is not permissible to load angle rotors on only one axis.

correct

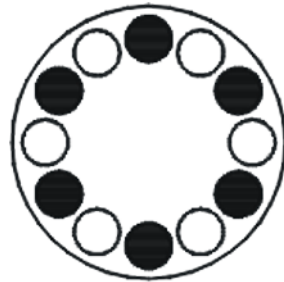
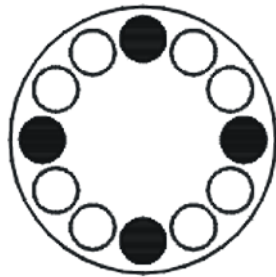

incorrect

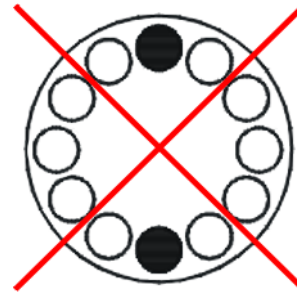

Fig. 8: Permissible and impermissible loading of an angle rotor (example illustration)

### 6.2.2.4 Vessels

- Load the vessels outside of the centrifuge. Liquids in the bores of the rotor cause corrosion.
- Fill the vessels carefully and arrange them according to their weight. Imbalances result in the excessive wear of the bearings.
- After the centrifugation, remove the vessels carefully in order to prevent the samples from mixing.
- Follow the safety instructions and hazard warnings (see chapter 3 - "Safety")!

## 6.3 Control System "Spincontrol Basic"

### 6.3.1 User interface

- 1 Display
- 2 Set key
- 3 Program key
- 4 Arrow keys
- 5 Lid key
- 6 Start/Stop key
- 7 Precool key



Fig. 9: User interface

The centrifuge is started directly via the user interface. When the centrifuge is switched on, all segments will be illuminated for a short time. It is now ready for operation.

### 6.3.2 Display

The centrifuge display has the following display fields:

- 1 Field for deceleration curves, run mode, and programs
- 2 Speed / RCF field
- 3 Time field
- 4 Field for temperature and rotor selection

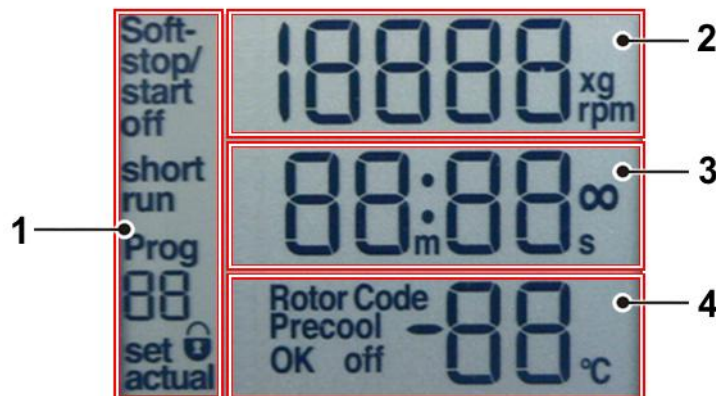

Fig. 10: Display, completely illuminated

## 6 Using the centrifuge

---

### 6.3.3 Starting a centrifugation run

The centrifuge is ready for operation when the mains power switch is on and the lid is closed.

- Press the start/stop key in order to start a centrifugation run.

During the centrifugation run, "actual" will be displayed in the lower left-hand area of the display.

### 6.3.4 Interrupting a centrifugation run

- Press the start/stop key in order to interrupt a centrifugation run. The centrifugation run will be terminated prematurely.

### 6.3.5 Interrupting a deceleration process

- Press the start/stop key during a deceleration process in order to interrupt it and to restart the centrifuge.

### 6.3.6 Speed / Relative centrifugal force (RCF)

The RCF value is determined by the rotor geometry and speed. The RCF and speed values, therefore, depend on each other. If one of the two values is entered, the other value will be set automatically.

- To enter a value, press the Set button repeatedly until the corresponding unit and the word "set" flash in the lower left-hand area of the display.
- Select the desired speed or RCF value via the arrow keys.

The data will be saved in the following situations:

- When a centrifugation run is started.
- After approx. 20 seconds if no other button is pressed during this time.

During operation, you can switch from the speed value to the RCF value and vice versa via the arrow keys.

#### 6.3.6.1 Changing the speed/RCF value during centrifugation

The preselected speed or RCF value can be changed during centrifugation.

- Press the set key repeatedly until the desired unit flashes on the display.
- Change the speed or RCF value by pressing the arrow keys. The parameters will take effect immediately.

### 6.3.7 Runtime

The preselected total runtime is displayed in the lower line of the display. During centrifugation, the remaining runtime is displayed. The runtime of the centrifuge can be set at one-second-intervals up to 99 minutes and 59 seconds.

- To enter a value, press the Set button repeatedly until the corresponding unit and the word "set" flash in the lower left-hand area of the display.
- Select the desired runtime by pressing the arrow keys.

The data will be saved in the following situations:

- When a centrifugation run is started.
- After approx. 20 seconds if no other button is pressed during this time.

#### 6.3.7.1 Changing the runtime during centrifugation

The preselected runtime can be changed during centrifugation.

- Press the "set" key repeatedly until the time unit flashes on the display.
- Change the desired runtime by pressing the arrow keys. The parameters will be accepted immediately.



If the centrifugation time is changed during the run, the centrifuge will run for the entire new time and will disregard the previous runtime that has already elapsed.

#### 6.3.7.2 Short run

During the short run, the centrifuge accelerates at maximum power until the maximum speed is reached.

- Keep the quick run key pressed during the short run.

The message "short run" and the duration of the short run are displayed.

When the quick run key is released, the centrifuge decelerates at maximum power to a standstill.

After the short run, the lid unlocks automatically and the program that was set beforehand is displayed again.

## 6 Using the centrifuge

---

### 6.3.7.3 Continuous run

During the continuous run, the runtime of the centrifuge is unlimited and must be stopped manually. The centrifuge accelerates during the continuous run until the set speed is reached.

- To start the continuous run, press the set key until the time unit flashes on the display.
- Press the down-key (arrow key) until the display switches from "00:10" to "--:--".

After 99 min 59 sec, any additional runtime will no longer be displayed, but the centrifugation will continue.

- To stop a continuous run, press the start/stop key. The centrifugation will end.
- Enter a runtime. The centrifugation will end after this time.

### 6.3.8 Temperature

The temperature in the rotor chamber is displayed in the lower third of the centrifuge display. The display alternates between the preselected temperature and the actual temperature. The actual temperature is marked by the word "actual" in front of the temperature value.

Temperatures between -10 °C and + 40 °C can be selected.

- Press the set key until the temperature unit flashes on the display.
- Select the desired temperature by pressing the arrow keys.
- Confirm the selection by pressing the start/stop key.

The data will also be accepted and saved after approx. 20 seconds if no other key is pressed within this time period.

#### 6.3.8.1 Precooling program "Precool"

Depending on the substances to be centrifuged, it may make sense to precool the centrifuge. The precooling prevents the cooled samples in the uncooled centrifuge from heating up to an inadmissible temperature.

Precooling at a standstill may distort the measurement results and subsequently cause increased wear of the mechanical components. This is why the centrifuge has a special program that precools the centrifuge under defined conditions:

- Press the precool key to load the precooling program. The display shows  $\frac{1}{3}$  of the maximum rotor speed and the corresponding RCF value, the runtime field indicates "∞" (continuous run). If the set temperature is above the actual temperature, it is limited to the actual temperature.



Once the precooling program is loaded, the set temperature can only be set to values below the actual temperature. If the limits of the setting range are reached during the setting process, the temperature display flashes for approximately 1 second.

## 6 Using the centrifuge

---

- Press the start key to start the precooling program.

Once the set value is reached and remains stable for one minute, the program ends with the indication "Precool OK".

- Press the precool key to terminate the precooling program prematurely. In this case, the indication "Precool off" flashes on the display.

If the precooling program is selected and then deselected without actually being started, the set temperature will be reset to the old value. If, however, the precooling run is started, the limited set temperature will also be used for the following runs, but it will not be saved in the program.

### 6.3.9 Softstart and softstop function

The softstart function is used to extend the acceleration time, whereas the softstop function is used to extend the deceleration time. The current combination is shown on the display.

- To activate the softstart and softstop functions, press the set key repeatedly until "Soft-stop/start" flashes in the upper left part of the display.
- Press the arrow keys until "Soft-stop/start on" is displayed. The softstart and softstop functions are now activated.
- Press the arrow key until "Soft stop on" is displayed. Only the softstop function will be active and the centrifuge will start at normal speed.
- Press the arrow key until "Soft off" is displayed. The softstart and softstop functions are now deactivated.

The data will be accepted immediately and saved after approx. 20 seconds. You can also change the settings as described above during a centrifugation run.

## 6 Using the centrifuge

### 6.3.10 Rotor selection

In the delivery status of the centrifuge, the rotor 12134 is preselected. If another rotor is installed the configuration must be changed, so that the allowed maximum speed of the rotor can be reached.

- To select another rotor, press the set key and hold it for approx. 2 seconds.
- Choose the number of the installed rotor out of the following list, by pressing the arrow keys:

<b>Code</b>	1	2	3	4	5
<b>Rotor</b>	11024	12024 12120	12134	12135	12136
<b>Code</b>	6	7	8	9	10
<b>Rotor</b>	12137	12180	12118	--	--

- Press the set key to confirm the input.  
The RCF value will be adjusted automatically to the selected rotor.



The rotor selection will be saved under the corresponding program number.

### 6.3.11 Button lock

In order to prevent any unauthorised use of the centrifuge, its buttons can be locked. In the factory settings, the button lock is deactivated.

- To activate the button lock, press the Start/Stop button 3 times while the lid is open. When pressing it the third time, hold it until the lock symbol is displayed.

The button lock is activated. The Start/Stop button, lid button, and arrow buttons for selecting the indication of the speed or RCF value remain active even if the button lock is active.

- Proceed in the same manner in order to deactivate the button lock.

### 6.3.12 Eco mode

The centrifuge has an Eco mode so that the refrigeration unit will be switched off after a preset time if the centrifuge is at a standstill.

The turn-off countdown begins in the background after the last keystroke while the centrifuge is at a standstill. If a key is pressed during the countdown, the countdown will be reset and started again.

After the end of the turn-off countdown, the refrigeration unit will be switched off. The display shows the speed value and the indication "Eco" in alternation.

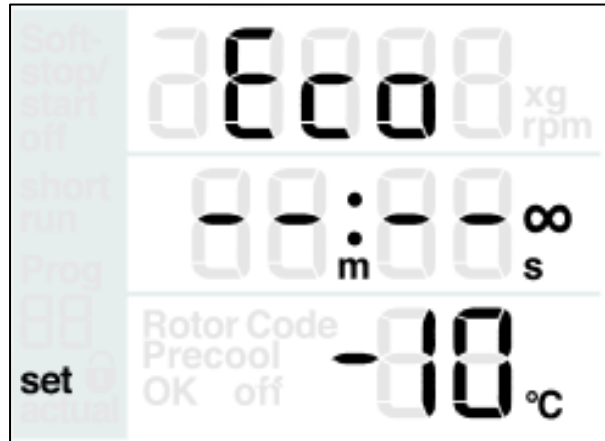

Fig. 11: Indication of the Eco mode and speed value in alternation

#### Activating the Eco mode and changing the turn-off time

The Eco mode is deactivated by default (factory settings). To activate it or to change the turn-off time, the centrifuge must be at a standstill and the centrifuge lid must be open.

- Press and hold the "Set" button and press the arrow button ↑ 8 times.
- Release the "Set" button. The Eco mode will be displayed.
- Select the desired turn-off time by way of the arrow buttons. The value can be preselected in a range between 1 h and 8 h and in steps of one hour.



Fig. 12: Adjusting the turn-off time

- Exit the display by pressing the "Set" button. The Eco mode is activated.

## 6 Using the centrifuge

### Deactivating the Eco mode

- Press and hold the "Set" button and press the arrow button ↑ 8 times.
- Release the "Set" button. The Eco mode will be displayed.
- Press the arrow button ↓ until "Eco off" is displayed.



Fig. 13: Deactivating the Eco mode

- Exit the display by pressing the "Set" button. The Eco mode is deactivated.

### 6.3.13 Program

The program is used to save or load certain recurrent settings of the centrifuge. 10 different programs can be saved and called up. The precooling program "Precool" does not occupy any storage location and cannot be deleted. It is used to cool the centrifuge without vessels (see chapter 6.3.8.1 - "Precooling program "Precool"").

#### 6.3.13.1 Saving the current settings

- Press the program key. Then, select a program number by pressing the arrow keys. The display "Prog - - " will now flash.
- Select the correct rotor.
- Press the set key repeatedly until the corresponding unit flashes on the display. Select the desired parameters.
- In order to save the data, start the centrifuge or press the set key repeatedly until the indication "Prog - -" stops flashing.



Program numbers that are already occupied will be overwritten with the current data.

#### 6.3.13.2 Calling up stored programs

- Press the program key. Then, select a program number by pressing the arrow keys. The display "Prog - - " will now flash.
- Ensure that the correct rotor is installed.
- In order to save the data, start the centrifuge or press the set key repeatedly until the indication "Prog - -" stops flashing.

## 6.4 Switching the centrifuge off

- Open the centrifuge when it is not in use so that moisture can evaporate.
- Switch the centrifuge off by pressing the mains power switch.

## 7 Malfunctions and error correction

# 7 Malfunctions and error correction

## 7.1 General malfunctions

Malfunctions are indicated by error messages with a number in the speed/RCF display.

In the event of a fatal error (e.g. a defective lid lock), a certain safety time will be counted down on the display. During this time, "ERR" and "SAFE" flash alternately on the display. When the time is up, "OFF" will be displayed.



**WARNING**

Do not switch the centrifuge off until "OFF" is displayed! This is necessary in order to ensure that the rotor is at a complete standstill.

- Eliminate the source of the problem (see tables below).
- Acknowledge the error messages with the lid key.

Type of error	Possible reason	Correction
No indication on the display	No power in the mains supply	Check fuse in the mains supply
	Power cord is not plugged in	Plug in power cord correctly
	Mains power switch off	Switch mains power switch on
	Lid is not closed correctly	Close the lid
Centrifuge cannot be started: The set speed value is displayed in an unchanged manner	Several possible causes	Netz aus/ein. Falls sich der Fehler wiederholt, Service verständigen
	The lid lock is not closed correctly	Open and close lid. If the error occurs again, contact service
Centrifuge decelerates during operation and displays an error from 1 to 18 after powering on	Several possible causes	Power off/on. If the error occurs again, contact service
Centrifuge decelerates during operation and displays error 19 after powering on	Several possible causes	Acknowledge by pressing the lid key
Lid cannot be opened	Lid locks have not released	Unlock the lid manually (see chapter 7.1.1 - "Emergency lid release") and contact service
	Lid seal sticks	Clean the lid seal and apply talcum powder
Temperature value cannot be reached (only for refrigerated centrifuges)	Condenser dirty	Contact service

### 7.1.1 Emergency lid release

In the event of a power failure, it is possible to manually open the centrifuge lid.

- Switch off the mains power switch and disconnect the power cord from the socket.
- Remove the plug (see figure, item 1) from the opening on the left side of the control panel, e.g. with a screwdriver.



Fig. 14: Position of the opening for the emergency lid release

- Insert the supplied hexagon socket key horizontally into the hole and turn it anti-clockwise to the stop. The lid lock will then audibly unlock.



Fig. 15: Manual release of the lid lock

- Then, reinsert the plug.



**WARNING**

Do not unlock or open the lid unless the rotor is at a standstill.

If the lid is opened via the emergency lid release system during a centrifuge run, the centrifuge will be switched off immediately and decelerate in an unbraked manner.

## 7 Malfunctions and error correction

### 7.2 Table of error codes

Error no.	Kind of error	Measures	Note
1-9	System error	<ul style="list-style-type: none"> <li>Allow to slow down</li> <li>Power off/on</li> </ul>	All these errors stop the centrifuge or cause it to decelerate brakeless
10-19	Speedometer error	<ul style="list-style-type: none"> <li>Allow to slow down</li> <li>Power off/on</li> </ul>	
20-29	Motor error	<ul style="list-style-type: none"> <li>Power off</li> <li>Ensure ventilation</li> </ul>	
30-39	EEPROM error	<ul style="list-style-type: none"> <li>Allow to slow down</li> <li>Power off/on</li> </ul>	With error 34, 35, and 36, the centrifuge will stop; with error 37 and 38 only an error message will be given
40-45	Temperature error (only for refrigerated centrifuges)	<ul style="list-style-type: none"> <li>Allow to slow down</li> <li>Power off</li> <li>Allow to cool down</li> <li>Provide better ventilation (only air-cooled centrifuges)</li> <li>Provide sufficient water throughput (only water-cooled centrifuges)</li> </ul>	
46-49	Imbalance error (only for centrifuges with imbalance monitoring system)	<ul style="list-style-type: none"> <li>Allow to slow down</li> <li>Power off</li> <li>Eliminate the imbalance</li> </ul>	
50-59	Lid error	<ul style="list-style-type: none"> <li>Press lid key</li> <li>Close lid</li> <li>Remove foreign matter from the opening of the lid lock device</li> </ul>	With error 50 and 51, the centrifuge will stop
60-69	Process error	<ul style="list-style-type: none"> <li>Allow to slow down</li> <li>Power off/on</li> </ul>	With error 60, the message "power failure during run" will be displayed, with error 61, the message "stop after power on" will be displayed
70-79	Communication error	<ul style="list-style-type: none"> <li>Allow to slow down</li> <li>Power off/on</li> </ul>	
80-89	Parameter error	<ul style="list-style-type: none"> <li>Power off</li> <li>Allow to cool down</li> <li>Provide for better ventilation</li> </ul>	With error 83, error message only
90-99	Other errors	<ul style="list-style-type: none"> <li>Check connections</li> <li>Provide sufficient water throughput (only water-cooled centrifuges)</li> </ul>	



If it is impossible to eliminate the errors, contact the service!

### 7.3 Service contact

In the event of queries, malfunctions, or spare part enquiries:

**From Germany:**

Contact

Sigma Laborzentrifugen GmbH  
An der Unteren Söse 50  
37520 Osterode (Germany)  
Tel. +49 (0) 55 22 / 50 07-44 44  
E-mail: support.lab@sigma-zentrifugen.de

**Outside Germany:**

Contact our agency in your country. All agencies are listed at  
[www.sigma-zentrifugen.de](http://www.sigma-zentrifugen.de) → [Sales Partners]



**NOTE**

- If you would like to utilise our service, please state the type of your centrifuge and its serial number.

## 8 Maintenance and service

### 8 Maintenance and service

The centrifuge, rotor, and accessories are subject to high mechanical stress. Thorough maintenance performed by the user extends the service life and prevents premature failure.



**CAUTION**

If corrosion or other damage occurs due to improper care, the manufacturer cannot be held liable or subject to any warranty claims.

#### 8.1 General

- The centrifuge and accessories are made from different materials. Please check for any possible incompatibilities.
- Prior to using cleaning agents and disinfectants other than those recommended, the user must consult with the manufacturer to ensure that they will not damage the centrifuge or its accessories.
- For autoclaving, the long-term temperature resistance of the individual materials must be observed (see chapter 8.1.1 - "Autoclaving").
- Do not subject the centrifuge or rotors to strong UV radiation (e.g. exposure to direct sunlight) or thermal stress (e.g. caused by heat generators).



**DANGER**

When using hazardous substances (e.g. infectious or pathogenic substances), it is mandatory to disinfect the centrifuge and its accessories.



**WARNING**

For your own protection, always take appropriate precautions if there is a risk of toxic, radioactive or pathogenic contamination. Wear personal protective equipment.

#### Frequency of the required activities

Chapter	Activity	Frequency
<b>8.1.1</b>	<b>Cleaning</b>	
8.1.1.1	Cleaning of the centrifuge	As required
8.1.1.2	Cleaning of rotors	As required
8.1.1.3	Cleaning of adapters	As required
<b>8.1.2</b>	<b>Disinfection</b>	
8.1.2.1	Disinfection of the centrifuge	As required
8.1.2.2	Disinfection of rotors	As required
8.1.2.3	Disinfection of adapters	As required

## 8 Maintenance and service

Chapter	Activity	Frequency
<b>8.2</b>	<b>Maintenance tasks</b>	
8.2.1	Inspection of the centrifuge for signs of damage	Monthly
8.2.1	Greasing of the motor shaft	After cleaning
8.2.1.1	Check of the condenser for soiling	Monthly
8.2.1.1	Cleaning of the condenser	As required
8.2.2	Check of the rotors, buckets and adapters for signs of damage	Monthly
8.2.2	Greasing of the rotor tie-down screw	After cleaning

### 8.1.1 Cleaning

- Use soapy water or other water-soluble, mild cleaning agents with a pH value between 6 and 8 for cleaning the centrifuge and its accessories.
- Clean the centrifuge by hand only.
- The water temperature must be < 40°C.
- Avoid corrosive and aggressive cleaning agents.
- Do not use any solvents.
- Do not use any agents with abrasive substances.



#### CAUTION

Ensure that no liquid penetrates the inside of the centrifuge. Otherwise, electrical or mechanical components can be damaged.

#### 8.1.1.1 Cleaning of the centrifuge

1. Open the lid.
2. Disconnect the centrifuge from the power supply.
3. Remove the rotors and buckets (see chapter 6.2.2 - "Installation of rotors and accessories").
4. Clean the housing and the rotor chamber with the specified cleaning agents and a soft, lint-free cloth.
5. Remove any cleaning agent residues completely with water and a soft, lint-free cloth.
6. After cleaning, dry the surfaces with a soft, lint-free and absorbent cloth.

## 8 Maintenance and service

---

### 8.1.1.2 Cleaning of rotors



#### CAUTION

#### **Do not clean the accessories in a dishwasher!**

The dishwasher will remove the anodised coating of the adapters and carriers, thereby leading to cracks in areas under stress.

1. Clean the rotor and buckets with the specified cleaning agents and a soft, lint-free cloth.
2. To clean narrow holes, use a test tube brush with a wool tip and then rinse the holes with water.
3. Remove any cleaning agent residues completely with water and a soft, lint-free cloth.
4. Dry the rotor and buckets with a soft, lint-free and absorbent cloth or in a drying cabinet at 50°C maximum.
5. To dry the holes, let the rotor dry lying upside down on a surface.

### 8.1.1.3 Cleaning of adapters

1. Clean the adapters with the specified cleaning agents and a soft, lint-free cloth.
2. To clean narrow holes, use a test tube brush with a wool tip and then rinse the holes with water.
3. Remove any cleaning agent residues completely with water and a soft, lint-free cloth.
4. Dry the adapters with a soft, lint-free and absorbent cloth.
5. To dry the holes, let the adapter dry lying upside down on a surface.

## 8.1.2 Disinfection



Prior to a disinfection, the cleaning steps described in chapter 8.1.1 - "Cleaning" must have been performed.

### 8.1.2.1 Disinfection of the centrifuge

- To disinfect the centrifuge (control panel, contact surfaces and rotor chamber), use an alcohol-based surface disinfectant with a concentration between 30% and 75% (e.g. Bacillol® AF).
  - Disinfect the lid window and the display (acrylic glass), motor cover (silicone) and (screen-printed) labelling with a disinfectant that is suitable for the material (e.g. Bacillol® 30 sensitive tissues). Never use a surface disinfectant with a high alcohol concentration!
  - Follow the manufacturer's instructions regarding the application time and concentration of the disinfectant.
1. Open the lid.
  2. Disconnect the centrifuge from the power supply.
  3. Remove the rotors and buckets (see chapter 6.2.2 - "Installation of rotors and accessories").
  4. Wipe down the housing and rotor chamber with the above-mentioned disinfectant and a soft, lint-free cloth.
  5. Comply with the specified application time.
  6. Let the disinfected surfaces dry completely.

### 8.1.2.2 Disinfection of rotors

- To disinfect the rotors, use an alcohol-based surface disinfectant with a concentration between 30% and 75% (e.g. Bacillol® AF).
  - Follow the manufacturer's instructions regarding the application time and concentration of the disinfectant.
1. Wipe down the rotor with the above-mentioned disinfectant and a soft, lint-free cloth.
  2. To disinfect narrow holes, fill them with the disinfectant without entrapping any air.
  3. Ensure complete wetting.
  4. Comply with the specified application time.
  5. Let the disinfected rotor dry completely.

## 8 Maintenance and service

---

### 8.1.2.3 Disinfection of adapters

- To disinfect the adapters, use an alcohol-based surface disinfectant with a concentration between 30% and 75% (e.g. Bacillo<sup>®</sup> AF).
  - Follow the manufacturer's instructions regarding the application time and concentration of the disinfectant.
1. Wipe down the adapters with the above-mentioned disinfectant and a soft, lint-free cloth.
  2. To disinfect narrow holes, fill them with the disinfectant without entrapping any air.
  3. Ensure complete wetting.
  4. Comply with the specified application time.
  5. Let the disinfected adapters dry completely.

### 8.1.1 Autoclaving

The service life of the accessories primarily depends on the autoclaving frequency and their general frequency of use.

- Replace the accessories immediately if you notice any leaks or any changes in the colour or structure, etc.
- When autoclaving, in order to prevent the vessels from being deformed, ensure that the caps are not screwed onto the vessels.



**NOTE**

The possibility of plastic parts, such as covers or racks, becoming deformed during autoclaving cannot be ruled out.



**NOTE**

The specified autoclaving parameters exclusively refer to the material resistance and not to the degree of sterility.

Category	Type of accessory	Material abbreviation	121°C 20 min	Notes
<b>Rotors and covers</b>	Aluminium rotors	AL	yes	
	Polypropylene rotors	PP	no	
	Polycarbonate covers for angle rotors	PC	no	
	Polyallomer covers for angle rotors	PA	no	
	Polysulfone covers for angle rotors	PSU	yes	100 cycles max.
<b>Buckets and caps</b>	Aluminium buckets	AL	yes	
	Polyamide buckets	PA	no	13035, 13296, 13299
	Polyphenylsulfone caps	PPSU	yes	100 cycles max.
	Polysulfone caps	PSU	yes	100 cycles max.
<b>Adapters</b>	Polyallomer racks	PA	no	
	Polyallomer racks	PC	no	
	Polyallomer racks	PP	no	
<b>Vessels</b>	Stainless steel vessels and bottles	--	yes	
	Glass vessels	--	yes	
	Polyethylene vessels	PE	no	
	Polyflor vessels	PF	yes	100 cycles max.
	Polycarbonate vessels	PC	no	
	Polypropylene copolymer vessels	PPCO	yes	20 cycles max.
	Polystyrene vessels	PS	no	
<b>Additional equipment</b>	Stainless steel taring weights for blood bag systems	--	yes	

## 8 Maintenance and service

---

### 8.2 Maintenance tasks

#### 8.2.1 Maintenance of the centrifuge

- Liquids, such as water, solvents, acids and lyes, must be removed from the rotor chamber immediately using a cloth. This prevents the motor bearings from being damaged.
- In the event of a contamination with toxic, radioactive or pathogenic substances, clean the inside of the centrifuge immediately with a suitable decontamination agent depending on the type of contamination (see chapter 8.1.1 - "Cleaning" and chapter 8.1.2 - "Disinfection").
- After every cleaning process, grease the motor shaft slightly with a small amount of heavy-duty grease for load-bearing bolts and distribute the grease with a cloth so that it forms a thin layer.
- Perform a visual inspection of the centrifuge at least monthly to detect the following signs of damage:
  - Cracks
  - Visible surface damage
  - Pressure marks
  - Signs of corrosion
  - Other changes

##### 8.2.1.1 Condenser (Only with air-cooled refrigeration system)

In order to cool the refrigerant that is compressed by the refrigeration unit, centrifuges with an air-cooled refrigeration system use a lamellar condenser. It is cooled by air.

Dust and dirt obstruct the cooling flow of air. The dust on condenser pipes and lamellas reduces the heat exchange and thus the performance of the refrigeration unit.

This is why the installation site should be as clean as possible.

- Check the condenser at least once a month for dirt and clean it if necessary.
- If you have any queries, please contact service (see chapter 7.3 - "Service contact").

## 8.2.2 Maintenance of rotors and adapters



### CAUTION

The special precautions for the care of the accessories must be strictly observed.

These are measures to ensure operational safety!

- Liquids that may cause corrosion must be immediately removed completely from the rotor and accessories by way of a cloth.
- In the event of a toxic, radioactive or pathogenic contamination of the rotors and accessories, clean them immediately with a suitable decontamination agent depending on the type of contamination. For your own protection, always take appropriate precautions if there is a risk of toxic, radioactive or pathogenic contamination (see chapter 8.1.1 - "Cleaning" und chapter 8.1.2 - "Disinfection").

Rotors and accessories are manufactured with the highest levels of precision in order to withstand the continuous, extreme levels of stress with their area of application with high centrifugal force.

Chemical reactions and pressure corrosion (a combination of alternating pressure and chemical reactions) can attack or destroy the structure of metals. Barely detectable cracks on the surface expand and weaken the material without leaving any clearly visible signs.

- This is why the material must be checked regularly, at least monthly, for the following:
  - Cracks
  - Visible surface damage
  - Pressure marks
  - Signs of corrosion
  - Other changes
- Check the holes of rotors.
- Damaged parts must be replaced immediately for your own safety.
- After every cleaning process, grease the rotor tie-down screw slightly with a small amount of heavy-duty grease for load-bearing bolts and distribute the grease with a cloth so that it forms a thin layer.
- Comply with the special requirements for the use of plastic accessories (see chapter 8.2.2.1 - "Plastic accessories").

### **Microhaematocrit rotor (part no. 11024)**

- Check the rubber ring (part no. 16003) regularly, at least once a month, and replace it in the event of wear or glass breakage.

## 8 Maintenance and service

### 8.2.2.1 Plastic accessories

The chemical resistance of plastic decreases with rising temperatures (e.g. during drying) (see chapter 11.3 - "Resistance data").

- If solvents, acids, or alkaline solutions have been used, clean the plastic accessories thoroughly.



**WARNING**

Plastic accessories must not be greased!

### 8.2.3 Broken glass



**CAUTION**

In the event of glass breakage, all shards must be removed immediately and completely (e.g. with a vacuum cleaner). Rubber cushions must be replaced since even thorough cleaning cannot remove all the glass particles.



**CAUTION**

There is a risk of injury due to sharp shards when removing the broken glass from the motor chamber.

- Wear personal protective equipment (e.g. gloves).

#### Potential consequences of broken glass

- Broken glass damages the surface coating (e.g. anodised aluminium) of the buckets, thereby causing corrosion.
- Broken glass on the rubber cushions of the buckets causes more glass breakage.
- Broken glass in the swivel bearings of the load-bearing bolts prevents the buckets and multiple carriers from swinging out evenly, thereby causing imbalance.
- Broken glass in the rotor chamber causes metallic abrasion due to the strong air circulation. This fine metal dust not only strongly contaminates the rotor chamber, rotor and samples, but it also damages the surface of the accessories, rotors and rotor chamber.

#### Removing broken glass and metal dust from the rotor chamber

1. Apply a thick layer of petroleum jelly or similar to the upper third of the rotor chamber.
2. Then, let the rotor rotate for a few minutes at medium speed (approx. 2,000 rpm). During this process, dust and glass particles will be bound in the grease.
3. Then, remove the grease together with the dust and glass particles by way of a cloth.
4. If necessary, repeat this process.

### 8.3 Maintenance and service



**DANGER**

In the case of maintenance or service requiring the removal of the housing panels, there is a risk of electric shock or mechanical injury.

- Maintenance and service tasks must only be carried out by authorised and specialised personnel.
- Following the completion of any type of maintenance or service, the authorised and specialised personnel must perform final inspection and testing in compliance with the relevant standards (see below).

The centrifuge is subject to high mechanical load. In order to withstand this stress, high-quality components are installed during the production of the centrifuge. However, wear may occur and it may not be visible from the outside. Especially rubber parts, which can be found in the motor suspension assembly, are subject to ageing.

Centrifuges used in Germany are subject to mandatory testing as per the information sheet of the German Berufsgenossenschaft Rohstoffe und chemische Industrie FBRCI-025 (November 2023):

- Every 1-2 years in operating condition
- Every 3-4 years in dismantled condition

We recommend the following:

- The motor suspension elements (rubber parts of the motor suspension) should be replaced every 3 to 4 years.
- The centrifuge should be tested annually in operating condition during an inspection performed by the manufacturer and every three years in dismantled condition.

#### **Repair, modification and requalification (repeat test)**

After any repair, modification or requalification (repeat test), an electrical safety test must be carried out by a qualified electrician in accordance with DIN EN 61010-1.

The specified test in accordance with DGUV V3, DIN EN 61010-1 must be performed for centrifuges made by Sigma. The test is considered as passed if the specified limits are complied with.

A measurement in accordance with VDE 0701-0702 leads to higher values, which is due to a different measurement method. If the limit values are also complied with in this case, the test is also considered as passed. If the limit values are exceeded, a test in accordance with DIN EN 61010-1 is mandatory.

## 8 Maintenance and service

These services can be agreed as part of a maintenance contract.

[www.sigma-zentrifugen.de](http://www.sigma-zentrifugen.de) → [Service] → [Overhaul and repair]

### Scan QR-Code

If you have any questions to this subject, please contact our service department:



### 8.4 Return of defective centrifuges or parts

Although we exercise great care during the production of our products, it may be necessary to return a unit or accessory to the manufacturer.

In order to ensure the quick and economical processing of returns of centrifuges, spare parts, or accessories, we require complete and extensive information concerning the process. Please fill in the following forms completely, sign them, enclose them with the return package, and send them together with the product to:

Sigma Laborzentrifugen GmbH  
An der Unteren Söse 50  
37520 Osterode (Germany)

#### 1. Declaration of decontamination

As a certified company and due to the legal regulations for the protection of our employees and of the environment, we are obliged to certify the harmlessness of all incoming goods. For this purpose, we require a declaration of decontamination.

- The form must be filled in completely and signed by authorised and specialised personnel only.
- Affix the original form in a clearly visible manner to the outside of the packaging.



We will return the part/unit if no declaration of decontamination is provided!

#### 2. Form for the return of defective parts

This form is for the product-related data. They facilitate the assignment, and they enable the quick processing of the return. If several parts are returned together in one packaging, please enclose a separate problem description for every defective part.

- A detailed problem description is necessary in order to perform the repair quickly and economically.



If the form does not include a description of the malfunction, neither a refund nor a credit note can be issued. In this case, we reserve the right to return the part/unit to you at your expense.

- Upon request, we will prepare and submit to you a cost estimate prior to performing the repair. Please confirm such cost estimate within 14 days. If the cost estimate has still not been confirmed after 4 weeks, we will return the defective part/unit. Please note that you must bear the incurred costs.

### **3. Pick-up order**

Upon request, we will commission a forwarding agent to collect the unit. In this case, complete the pick-up order and return it to us by e-mail.



The defective part/unit must be packaged in a transport-safe manner. Please use the original packaging for the unit, if at all possible. If the product is dispatched to us in unsuitable packaging, you will be charged the cost for returning it to you in new packaging.

The forms can be downloaded online from [www.sigma-zentrifugen.de](http://www.sigma-zentrifugen.de) → [Service] → [Overhaul and repair].

## 9 Disposal

---

### 9 Disposal

#### 9.1 Disposal of the centrifuge



In accordance with the directive 2012/19/EU, SIGMA centrifuges are marked with the symbol shown to the left. This symbol means that it is not permissible to dispose of the unit among household waste.

- You can return these centrifuges free of cost to Sigma Laborzentrifugen GmbH.
- Ensure that the unit is decontaminated. Fill in a declaration of decontamination (see chapter 8.4 - "Return of defective centrifuges or parts").
- Comply with any other applicable local rules and regulations.

#### 9.2 Disposal of the packaging

- Use the packaging to return the centrifuge for disposal or
- dispose of the packaging, after having separated the individual materials.
- Comply with all local rules and regulations.

## 10 Technical data

<b>Manufacturer:</b>	<b>Sigma Laborzentrifugen GmbH An der Unteren Söse 50 37520 Osterode (Germany)</b>	
Type:	1-16K	1-16K IVD
Order no.:	10046, 10047, 10048	10052, 10053, 10054
<u>Connection requirements</u>		
Electrical connection:	see name plate	
Protection class:	I	
IP code:	20	
Power consumption (W):	540 (at 220-240 V / 50/60 Hz) 540 (at 120 V / 60 Hz) 540 (at 100 V / 50/60 Hz)	
Input fuse (AT):	10.0 (at 220-240 V / 50/60 Hz) 10.0 (at 120 V / 60 Hz) 10.0 (at 100 V / 50/60 Hz)	
<u>Performance data</u>		
Max. speed (rpm):	15,000	
Max. capacity (ml):	72	
Max. gravitational field (x g):	20,627	
Max. kinetic energy (Nm):	5,176	
<u>Other parameters</u>		
Time range:	10 sec – 99 min 59 sec, short run, continuous run	
Temperature range:	-10°C to +40°C	
<u>Physical data</u>		
Height (mm):	291	
Height with open lid (mm):	547	
Width (mm):	310	
Depth (mm):	660	
Weight (kg):	34	
Noise level (dB(A)):	54 (at max. speed)	
<u>Refrigerant data</u>		
Refrigerant:	R513A	
Global warming potential (GWP):	631	
Filling quantity (kg):	0.136	
Max. permissible pressure (bar):	23	
CO <sub>2</sub> equivalent (t):	0.086	

## 10 Technical data

---

### 10.1 Ambient conditions

- The figures are valid for an ambient temperature of +23°C and a nominal voltage  $\pm 10\%$ . The minimum temperature is  $\leq +4^\circ\text{C}$  and depends on the rotor type, speed, and ambient temperature.



At a nominal voltage of 100V or 200V, a tolerance of +10% / -5% applies.

- For indoor use only.
- Maximum altitude 2,000 m above sea level.
- Allowable ambient temperature +5°C to +35°C.
- Max. allowable relative humidity of air 80% from 5°C up to 31°C with a linear decrease to 67% relative humidity of air at 35°C.
- Pollution degree 2.

### 10.2 Technical documentation

For environmental reasons, the comprehensive technical documentation of the centrifuge (e.g. circuit diagrams) and the safety data sheets of the manufacturers of refrigerants and lubricants are not attached to this documentation.

You can order these documents from our service department.

## 11 Appendix

### 11.1 Range of accessories

The complete list of accessories can be downloaded from [www.sigma-zentrifugen.de](http://www.sigma-zentrifugen.de).

#### 11.1.1 Rotor radii

The information in the accessories table concerning the radius refers to the values of the respective rotor as shown below. The radius calculation is described in chapter 2.2.2.1 - "Speed, radius, and relative centrifugal force".

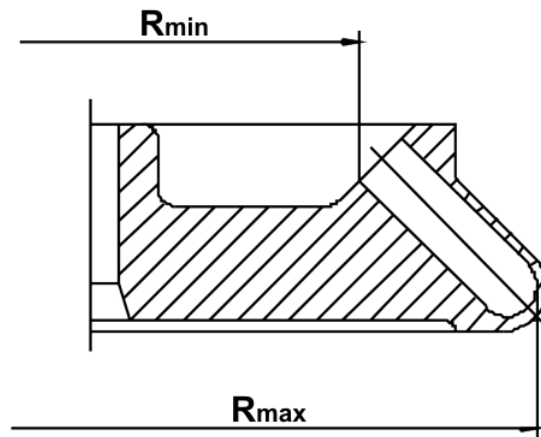

Fig. 16: Minimum and maximum radius of an angle rotor

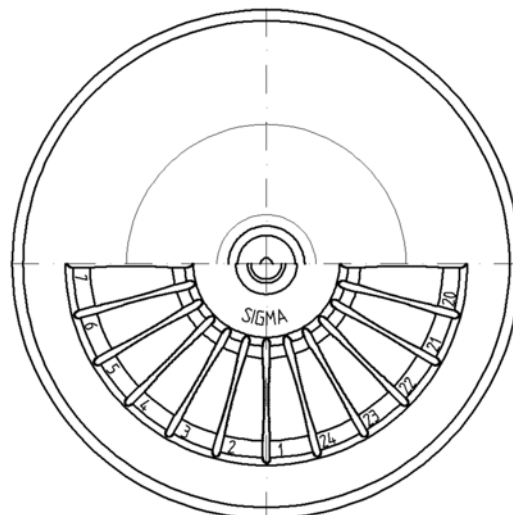

Fig. 17: Microhaematocrit rotor

## 11 Appendix

### 11.2 Table of the service life of rotors and accessories

- The rotors and accessories must be put out of service after 10 years. Any use after this period may be permissible in individual cases after an inspection performed by the manufacturer.
- If a specification concerning the maximum number of cycles and a specification concerning the service life (i.e. a date) are provided, the specification that occurs first shall apply.
- After 50,000 cycles, rotors must be scrapped for safety reasons.

Rotor / bucket	Cycles	Service life ("Exp.Date")	Suitable for centrifuge	Remarks
12082		7 years	1-14, 1-14K	
12084		7 years	1-14, 1-14K	
12092		5 years	1-14, 1-14K	
12094		5 years	1-14, 1-14K	
12096		5 years	1-14, 1-14K	
12097		5 years	1-14, 1-14K	
12134		5 years	1-16, 1-16K	
12135		5 years	1-16, 1-16K	
12137		5 years	1-16, 1-16K	
91429		7 years	1-7	
13035			2-7	Do not grease the load-bearing bolts of the rotor
13296	35,000	5 years	2-7, 2-16KL, 2-16KHL	Do not grease the load-bearing bolts of the rotor
13299		5 years	2-7, 2-7 Cyto, 2-16KL, 2-16KHL, 3-30KS, 3-30KHS	Do not grease the load-bearing bolts of the rotor
13221	10,000		4-16S, 4-16KS, 4-16KHS, 6-16S, 6-16HS, 6-16KS, 6-16KHS	
9100	35,000		4-5KL, 4-16S, 4-16KS, 4-16KHS, 6-16S, 6-16HS, 6-16KS, 6-16KHS	
9366	15,000		4-5KL, 4-16S, 4-16KS, 4-16KHS, 6-16S, 6-16HS, 6-16KS, 6-16KHS	
13218	20,000		4-5KL, 4-16S, 4-16KS, 4-16KHS, 6-16S, 6-16HS, 6-16KS, 6-16KHS	
12600		7 years	6-16S, 6-16HS, 6-16KS, 6-16KHS	
13625	20,000		6-16S, 6-16HS, 6-16KS, 6-16KHS	
13635	25,000		6-16S, 6-16HS, 6-16KS, 6-16KHS	
13650	20,000		6-16S, 6-16HS, 6-16KS, 6-16KHS	
13860	15,000	10 years	8KBS	
11805	15,000	10 years	8KBS, 8KS	
11806		10 years	8KBS, 8KS	
12505	30,000		8KS	
13845	20,000		8KS	
13850	10,000	10 years	8KS	
13890	25,000		8KS Clinic	

### 11.3 Resistance data



The data refer to resistance at 20°C.

- no data 1 resistant 2 practically resistant 3 partially resistant 4 not resistant	Concentration	High Density Polyethylene	Polyamide	Polycarbonate	Polyoxymethylene	Polypropylene	Polysulfone	Polyvinyl chloride, hard	Polyvinyl chloride, soft	Polytetrafluorethylene	Acrylonitrile-butadiene-caoutchouc	Aluminium	
													Medium
Acetaldehyde	C <sub>2</sub> H <sub>4</sub> O	40	3	2	4	2	3	4	4	-	1	4	1
Acetamide	C <sub>2</sub> H <sub>5</sub> NO	saturated	1	1	4	1	1	4	4	-	1	-	1
Acetone	C <sub>3</sub> H <sub>6</sub> O	100	1	1	4	1	1	4	4	-	1	4	1
Acrylonitrile	C <sub>3</sub> H <sub>3</sub> N	100	1	1	4	3	3	4	4	4	1	4	1
Allyl alcohol	C <sub>3</sub> H <sub>6</sub> O	96	1	3	3	2	2	2	2	4	1	1	1
Aluminium chloride	AlCl <sub>3</sub>	saturated	1	3	2	4	1	-	1	-	1	1	4
Aluminium sulfate	Al <sub>2</sub> (SO <sub>4</sub> ) <sub>3</sub>	10	1	1	1	3	1	1	1	1	1	1	1
Ammonium chloride	(NH <sub>4</sub> )Cl	aqueous	1	1	1	2	1	1	1	1	1	1	3
Ammonium hydroxide	NH <sub>3</sub> + H <sub>2</sub> O	30	1	3	4	1	1	2	1	-	1	-	1
Aniline	C <sub>6</sub> H <sub>7</sub> N	100	1	3	4	1	2	4	4	4	1	4	1
Anisole	C <sub>7</sub> H <sub>8</sub> O	100	3	4	4	1	4	4	2	-	1	4	1
Antimony trichloride	SbCl <sub>3</sub>	90	1	4	1	4	1	-	1	-	1	-	4
Benzaldehyde	C <sub>7</sub> H <sub>6</sub> O	100	1	3	4	1	1	3	4	4	1	4	1
Benzene	C <sub>6</sub> H <sub>6</sub>	100	3	2	4	1	3	4	4	-	1	4	1
Boric acid	H <sub>3</sub> BO <sub>3</sub>	aqueous	1	3	1	2	1	-	-	-	1	1	1
Butyl acrylate	C <sub>7</sub> H <sub>12</sub> O <sub>2</sub>	100	1	2	4	2	3	4	4	4	1	-	1
Butyl alcohol, normal	C <sub>4</sub> H <sub>10</sub> O	100	1	1	2	1	1	2	2	4	1	1	1
Calcium chloride	CaCl <sub>2</sub>	alcoholic	1	4	2	3	1	-	-	4	1	1	3
Carbon disulfide	CS <sub>2</sub>	100	4	3	4	2	4	4	4	4	1	3	1
Carbon tetrachloride (TETRA)	CCl <sub>4</sub>	100	4	4	4	2	4	4	4	4	1	3	1
Chlorine	Cl <sub>2</sub>	100	4	4	4	4	4	4	4	4	1	-	3
Chlorine water	Cl <sub>2</sub> x H <sub>2</sub> O		3	4	4	4	3	-	3	3	1	-	4
Chlorobenzene	C <sub>6</sub> H <sub>5</sub> Cl	100	3	4	4	1	3	4	4	4	1	4	1
Chloroform	CHCl <sub>3</sub>	100	3	3	4	4	3	4	4	4	1	4	3

## 11 Appendix

- no data 1 resistant 2 practically resistant 3 partially resistant 4 not resistant		Concentration	High Density Polyethylene	Polyamide	Polycarbonate	Polyoxymethylene	Polypropylene	Polysulfone	Polyvinyl chloride, hard	Polyvinyl chloride, soft	Polytetrafluorethylene	Acrylonitrile-butadiene-caoutchouc	Aluminium	
			Medium	Formula	[%]	HDPE	PA	PC	POM	PP	PSU	PVC	PVC	PTFE
	Chromic acid	CrO <sub>3</sub>	10	1	4	2	4	1	4	1	-	1	4	1
	Chromic potassium sulphate	KCr(SO <sub>4</sub> ) <sub>2</sub> x 12H <sub>2</sub> O	saturated	1	2	1	3	1	-	1	-	1	-	3
	Citric acid	C <sub>6</sub> H <sub>8</sub> O <sub>7</sub>	10	1	1	1	2	1	1	1	1	1	1	1
	Citric acid	C <sub>6</sub> H <sub>8</sub> O <sub>7</sub>	50	1	3	1	2	1	-	-	-	1	1	1
	Copper sulphate	CuSO <sub>4</sub> x 5H <sub>2</sub> O	10	1	1	1	1	1	1	1	1	1	1	4
	Cyclohexanol	C <sub>6</sub> H <sub>12</sub> O	100	1	1	3	1	1	1	1	4	1	2	1
	Decane	C <sub>10</sub> H <sub>22</sub>	100	-	1	2	1	3	-	-	-	1	2	1
	Diaminoethane	C <sub>2</sub> H <sub>8</sub> N <sub>2</sub>	100	1	1	3	1	1	-	3	4	1	1	1
	Diesel fuel	—	100	1	1	3	1	1	-	1	3	1	1	1
	Dimethyl formamide (DMF)	C <sub>3</sub> D <sub>7</sub> NO	100	1	1	4	1	1	4	3	-	1	3	1
	Dimethyl sulfoxide (DMSO)	C <sub>2</sub> H <sub>6</sub> SO	100	1	2	4	1	1	4	4	-	1	-	1
	Dimethylaniline	C <sub>8</sub> H <sub>11</sub> N	100	-	3	4	2	4	-	-	-	1	-	1
	Dioxane	C <sub>4</sub> H <sub>8</sub> O <sub>2</sub>	100	2	1	4	1	3	2	3	4	1	3	1
	Dipropylene glycol (mono)methyl ether	C <sub>4</sub> H <sub>10</sub> O	100	3	1	4	1	4	4	4	4	1	-	1
	Ethyl acetate	C <sub>4</sub> H <sub>8</sub> O <sub>2</sub>	100	1	1	4	1	1	4	4	4	1	4	1
	Ethylene chloride	C <sub>2</sub> H <sub>4</sub> Cl <sub>2</sub>	100	3	3	4	1	3	4	4	4	1	-	1
	Ferrous chloride	FeCl <sub>2</sub>	saturated	1	3	1	3	1	1	1	1	1	-	4
	Formaldehyde solution	CH <sub>2</sub> O	30	1	3	1	1	1	-	-	-	1	2	1
	Formic acid	CH <sub>2</sub> O <sub>2</sub>	100	1	4	3	4	1	3	3	1	1	2	1
	Furfural	C <sub>5</sub> H <sub>4</sub> O <sub>2</sub>	100	1	3	3	2	4	-	-	-	1	4	1
	Gasoline	C <sub>5</sub> H <sub>12</sub> - C <sub>12</sub> H <sub>26</sub>	100	2	1	3	1	3	3	2	-	1	1	1
	Glycerol	C <sub>3</sub> H <sub>8</sub> O <sub>3</sub>	100	1	1	3	1	1	1	1	2	1	1	1
	Heptane, normal	C <sub>7</sub> H <sub>16</sub>	100	2	1	1	1	2	1	2	4	1	1	1
	Hexane, n-	C <sub>6</sub> H <sub>14</sub>	100	2	1	2	1	2	1	2	4	1	1	1
	Hydrogen chloride	HCl	5	1	4	1	4	1	1	1	-	1	2	4
	Hydrogen chloride	HCl	concentrated	1	4	4	4	1	1	2	3	1	4	4
	Hydrogen peroxide	H <sub>2</sub> O <sub>2</sub>	3	1	3	1	1	1	1	1	-	1	3	3
	Hydrogen peroxide	H <sub>2</sub> O <sub>2</sub>	30	1	4	1	4	1	1	1	-	1	3	3
	Hydrogen sulphide	H <sub>2</sub> S	10	1	1	1	1	1	1	1	3	1	3	1
	Iodine, tincture of	I <sub>2</sub>		1	4	3	1	1	-	4	4	1	1	1

**11 Appendix**

- no data 1 resistant 2 practically resistant 3 partially resistant 4 not resistant	Medium	Formula	Concentration [%]	High Density Polyethylene	Polyamide	Polycarbonate	Polyoxymethylene	Polypropylene	Polysulfone	Polyvinyl chloride, hard	Polyvinyl chloride, soft	Polytetrafluorethylene	Acrylonitrile-butadiene- caoutchouc	Aluminium
				HDPE	PA	PC	POM	PP	PSU	PVC	PVC	PTFE	NBR	AL
Isopropyl alcohol	C <sub>3</sub> H <sub>8</sub> O	100	1	1	1	1	1	1	1	1	4	1	-	2
Lactic acid	C <sub>3</sub> H <sub>6</sub> O <sub>3</sub>	3	1	3	1	2	1	1	1	2	-	1	1	1
Magnesium chloride	MgCl <sub>2</sub>	10	1	1	1	1	1	1	1	1	1	1	1	1
Mercuric chloride	HgCl <sub>2</sub>	10	1	4	1	3	1	1	1	1	1	1	1	4
Mercury	Hg	100	1	1	1	1	1	1	1	1	3	1	1	3
Methyl acetate	C <sub>3</sub> H <sub>6</sub> O <sub>2</sub>	100	1	1	4	2	1	-	4	4	4	1	-	1
Methyl alcohol	CH <sub>4</sub> O	100	1	2	4	1	1	3	1	3	1	2	2	1
Methyl benzene	C <sub>7</sub> H <sub>8</sub>	100	3	1	4	1	3	4	4	4	4	1	4	1
Methyl ethyl ketone (MEK)	C <sub>4</sub> H <sub>8</sub> O	100	1	1	4	1	1	4	4	4	4	1	4	1
Methylene chloride	CH <sub>2</sub> Cl <sub>2</sub>	100	4	3	4	3	3	4	4	4	4	1	-	1
Mineral oil	—	100	1	1	1	1	1	1	1	1	-	1	1	1
Nitric acid	HNO <sub>3</sub>	10	1	4	1	4	1	1	1	1	-	1	4	3
Nitric acid	HNO <sub>3</sub>	100	4	4	4	4	4	4	-	4	-	1	4	1
Nitrobenzene	C <sub>6</sub> H <sub>5</sub> NO <sub>2</sub>	100	3	4	4	3	2	4	4	4	4	1	4	1
Oleic acid	C <sub>18</sub> H <sub>34</sub> O <sub>2</sub>	100	1	1	1	2	1	-	1	-	1	3	3	1
Oxalic acid	C <sub>2</sub> H <sub>2</sub> O <sub>4</sub> x 2H <sub>2</sub> O	100	1	3	1	4	1	1	1	1	1	1	2	1
Ozone	O <sub>3</sub>	100	3	4	1	4	3	1	1	1	-	1	4	2
Petroleum	—	100	1	1	3	1	1	1	1	1	3	1	1	1
Phenol	C <sub>6</sub> H <sub>6</sub> O	10	1	4	4	4	1	4	1	3	1	3	3	1
Phenol	C <sub>6</sub> H <sub>6</sub> O	100	2	4	4	4	1	3	4	3	1	3	3	1
Phosphoric acid	H <sub>3</sub> PO <sub>4</sub>	20	1	4	2	4	1	-	-	-	-	1	2	4
Phosphorus pentachloride	PCl <sub>5</sub>	100	-	4	4	4	1	-	4	4	4	1	-	1
Potassium hydrogen carbonate	CHKO <sub>3</sub>	saturated	1	1	2	1	1	-	-	-	-	1	-	4
Potassium hydroxide	KOH	30	1	1	4	3	1	1	1	1	1	1	-	4
Potassium hydroxide	KOH	50	1	1	4	3	1	1	1	1	1	1	-	4
Potassium nitrate	KNO <sub>3</sub>	10	1	1	1	1	1	-	-	-	-	1	1	1
Potassium permanganate	KMnO <sub>4</sub>	100	1	4	1	1	1	-	1	-	1	3	3	1
Pyridine	C <sub>5</sub> H <sub>5</sub> N	100	1	1	4	1	3	4	4	4	4	1	4	1
Resorcinol	C <sub>6</sub> H <sub>6</sub> O <sub>2</sub>	5	1	4	2	3	1	4	2	2	-	1	-	2
Silver nitrate	AgNO <sub>3</sub>	100	1	1	1	1	1	1	1	1	1	1	2	4

## 11 Appendix

- no data 1 resistant 2 practically resistant 3 partially resistant 4 not resistant		Concentration	High Density Polyethylene	Polyamide	Polycarbonate	Polyoxymethylene	Polypropylene	Polysulfone	Polyvinyl chloride, hard	Polyvinyl chloride, soft	Polytetrafluorethylene	Acrylonitrile-butadiene-caoutchouc	Aluminium	
			Medium	Formula	[%]	HDPE	PA	PC	POM	PP	PSU	PVC	PVC	PTFE
	Sodium bisulphite	NaHSO <sub>3</sub>	10	1	1	2	4	1	-	-	-	1	1	1
	Sodium carbonate	Na <sub>2</sub> CO <sub>3</sub>	10	1	1	1	1	1	-	-	-	1	-	3
	Sodium chloride	NaCl	30	1	1	1	1	1	1	1	1	1	1	3
	Sodium hydroxide	NaOH	30	1	1	4	1	1	1	1	1	1	2	4
	Sodium hydroxide	NaOH	50	1	1	4	1	1	1	1	-	1	2	4
	Sodium sulfate	Na <sub>2</sub> SO <sub>4</sub>	10	1	1	1	1	1	1	1	1	1	1	1
	Spirits	C <sub>2</sub> H <sub>6</sub> O	96	1	1	1	1	1	1	1	3	1	-	1
	Styrene	C <sub>8</sub> H <sub>8</sub>	100	4	1	4	1	3	-	4	4	1	4	1
	Sulphuric acid	H <sub>2</sub> SO <sub>4</sub>	6	1	4	1	4	1	1	1	-	1	2	3
	Sulphuric acid	H <sub>2</sub> SO <sub>4</sub>	fuming	4	4	4	4	4	4	4	4	1	4	3
	Tallow	—	100	1	1	1	1	1	-	1	1	1	1	1
	Tetrahydrofuran (THF)	C <sub>4</sub> H <sub>8</sub> O	100	3	1	4	1	3	4	4	4	1	3	1
	Tetrahydronaphthalene	C <sub>10</sub> H <sub>12</sub>	100	3	1	4	1	4	4	4	4	1	-	1
	Thionyl chloride	Cl <sub>2</sub> SO	100	4	4	4	2	4	4	4	4	1	-	3
	Tin chloride	SnCl <sub>2</sub>	10	1	4	2	2	1	-	-	-	1	1	4
	Transformer oil	—	100	1	1	3	3	1	1	1	-	1	1	1
	Trichloroethane	C <sub>2</sub> H <sub>3</sub> Cl <sub>3</sub>	100	3	3	4	2	4	4	4	4	1	4	4
	Urea	CH <sub>4</sub> N <sub>2</sub> O	10	1	1	1	1	1	-	-	-	1	1	1
	Urine	—	100	1	1	1	1	1	-	1	1	1	-	2
	Vinegar	C <sub>2</sub> H <sub>4</sub> O <sub>2</sub>	10	1	4	1	1	1	1	1	1	1	2	1
	Vinegar	C <sub>2</sub> H <sub>4</sub> O <sub>2</sub>	90	1	4	4	4	1	3	1	4	1	-	1
	Wax	—	100	-	1	1		1	-	-	-	1	-	1
	Wines	—	100	1	1	1	2	1	1	1	1	1	-	4
	Xylene	C <sub>8</sub> H <sub>10</sub>	100	3	1	4	1	4	4	4	4	1	4	1

## 11.4 EC declaration of conformity



### EC Declaration of Conformity

in accordance with the EC Machinery Directive 2006/42/EC, annex II, part 1, section A

<b>Product designation</b>	Laboratory centrifuge	
<b>Product name</b>	Sigma 1-16K	
<b>Order number</b>	10046, 10047, 10048	
<b>Manufacturer</b>	Sigma Laborzentrifugen GmbH An der Unteren Söse 50 37520 Osterode Germany	
<b>Authorised representative for CE matters</b>	Alexander Hörsting	

The product named hereinabove was developed, designed, and manufactured in compliance with the relevant, fundamental safety and health requirements of the listed EC regulations, directives and norms. In the event of modifications that were not authorised by the manufacturer or if the product is used in a manner that is not in line with the intended purpose, this declaration will be rendered void.

<b>Regulations</b>	Implementation Regulation for Regulation (EU) 2024/573 (F-gases Regulation)	(EU) 2024/2729
<b>Directives</b>	Machinery Directive	2006/42/EC
	Low Voltage Directive	2014/35/EU
	EMC Directive	2014/30/EU
	RoHS Directive	2011/65/EU
	Delegated RoHS Directive	(EU) 2015/863
<b>Norms</b>		EN 61010-2-020:2017 EN IEC 61010-2-011:2021 EN IEC 61326-1:2021

Osterode, 2025-11-04

*Michael Sander*

Dr. Michael Sander, Managing Director

CE\_Sigma\_1-16K\_MRL\_2025-11-04\_en
1 / 1

## 11 Appendix

---



## EC Declaration of Conformity

<b>Product designation</b>	Laboratory centrifuge
<b>Product name</b>	Sigma 1-16K IVD
<b>Part numbers</b>	10052, 10053, 10054
<b>Manufacturer</b>	Sigma Laborzentrifugen GmbH An der Unteren Söse 50 37520 Osterode Germany
<b>Basic UDI as referred to in Part C of Annex VI</b>	426073439IVD01001JQCJ4
<b>Single Registration Number (SRN)</b>	DE-MF-000009414

As the manufacturer of the unit(s), we assume full responsibility and hereby declare that the product(s) mentioned hereinabove comply with the requirements as set out in the following regulation(s)/directive(s).

<b>Regulations</b>	Regulation on in vitro diagnostica	(EU) 2017/746
	Implementation Regulation for Regulation (EU) 2024/573 (F-gases Regulation)	(EU) 2024/2729
<b>Directives</b>	RoHS Directive	2011/65/EU
	Delegated RoHS Directive	(EU) 2015/863
<b>Risk class in accordance with Annex VIII</b>	class A	

Osterode, 2025-11-04



Dr. Michael Sander, Managing Director

## 11 Appendix

---

## 11.5 Declaration of conformity – China RoHS 2



### DECLARATION OF CONFORMITY

#### China RoHS 2 (Administrative Measures for the Restriction of the Use of Hazardous Substances in Electrical and Electronic Products)

Laboratory centrifuge models: Sigma 1-14, 1-14K, 1-7, 1-16, 1-16K, 2-7, 2-16P, 2-16KL, 2-16KHL, 3-16L, 3-16KL, 3-18KS, 3-18KHS, 3-30KS, 3-30KHS, 4-5L, 4-5KL; 4-5KRL, 4-16S, 4-16KS, 4-16KHS, 6-16S, 6-16HS, 6-16KS, 6-16KHS, 8KS, 8KBS

Sigma Laborzentrifugen GmbH has made reasonable effort to avoid the use of hazardous substances in the products it manufactures (laboratory centrifuges).

A Product Conformity Assessment (PCA) was performed in order to determine whether the concentration of harmful substances in all homogeneous materials of the component parts is above or below the MCV limit (Maximum Concentration Value limit) as defined in GB/T 26572:

Mercury and its compounds: 0.1 %      Cadmium (Cd) and its compounds: 0.01 %  
 Lead (Pb) and its compounds: 0.1 %      Hexavalent chromium (Cr (VI)) and its compounds: 0.1 %  
 Polybrominated biphenyls (PBB): 0.1 %      Polybrominated diphenyl ethers (PBDE): 0.1 %

表1 产品中有害物质的名称及含量  
 Table 1: Name and content of hazardous substances in the product

部件名称 Component part (PCA)	有害物质 Hazardous substance					
	铅 Lead (Pb)	汞 Mercury (Hg)	镉 Cadmium (Cd)	六价铬 Hexavalent Chromium (Cr (VI))	多溴联苯 Poly-brominated biphenyls (PBB)	多溴二苯醚 Polybrominated diphenyl ethers (PBDE)
Electronic PCB, cables	X <sup>1)</sup>	○	○	○	○	○
Display	○	○	○	○	○	○
Housing	X <sup>2)</sup>	○	○	○	○	○
Base, metal, accessories	X <sup>2)</sup>	○	○	○	○	○

本表格依据SJ/T 11364的规定编制。  
 This table is made according to SJ/T 11364.

## 11 Appendix



O: 表示该有害物质在该部件所有均质材料中的含量均在GB/T 26572规定的限量要求以下。  
Indicates that the content of the harmful substance in all homogeneous materials of the component part is below the limit as defined in GB/T 26572.)

X: 表示该有害物质至少在该部件的某一均质材料中的含量超出GB/T 26572规定的限量要求。(企业可在此处, 根据实际情况对上表打“X”的技术原因进行进一步说明。)  
Indicates that the content of the harmful substance in at least one homogeneous material of the component part exceeds the limit as defined in GB/T 26572. (Contact the manufacturer for further technical information according to the actual situation.)

1) Contains parts in compliance with exemptions 6c, 7c.I, 7c.II and 37 of 2011/65/EU RoHS.

2) Contains parts in compliance with exemptions 6a, 6b and 6c of 2011/65/EU RoHS.

Apart from the exemptions given in this table, none of the substances listed above have been intentionally added to the product or metallic coatings.

### **Sigma Laborzentrifugen GmbH**

An der Unteren Söse 50  
37520 Osterode  
Germany

Osterode, 2024-04-25



M. Weigoni, Director of Procurement

## 12 Index

### A

Acceleration time	
- see also the softstart and softstop function	
.....	43
Accessories	
Changes in colour.....	59
Changes in structure.....	59
Leaks.....	59
Service life.....	59
Accessories, cleaning and care.....	62
Acid.....	25, 61, 63
Adapters, disinfection.....	58
Alkaline solutions.....	25, 63
Ambient conditions.....	69
Ambient temperature.....	69
Application examples.....	13
Autoclaving.....	59
Deformation of vessels.....	59

### B

Broken glass.....	63
Broken glass and metal dust, removal from the rotor chamber.....	63
Buckets, cleaning and care.....	62
Button lock.....	44

### C

Calling up stored programs.....	47
Capacity.....	68
Capillary tubes.....	37
CE mark in compliance with the directive 2006/42/EC.....	15
Centrifugation of infectious, toxic, radioactive, or pathogenic substances.....	24
Centrifugation principle.....	13
Centrifugation with low capacity.....	38
Centrifuge cannot be started.....	48
Centrifuge decelerates during operation....	48
Centrifuge, service life.....	27
Changes in colour (accessories).....	59
Changes in structure (accessories).....	59
Changing the runtime during centrifugation	41

Changing the speed/RCF value during centrifugation.....	40
Chemical and biological safety.....	24
Chemical resistance of plastic.....	63
China RoHS 2 – Declaration of conformity.	80
Cleaning agents.....	54
Cleaning of the centrifuge.....	55
Closing the lid.....	22, 35
CO <sub>2</sub> equivalent.....	68
Communication error.....	51
Condensation.....	33
Condenser maintenance.....	61
Contamination.....	24
Continuous run.....	42
Copyright.....	9
Corrosion.....	22, 25, 27, 38, 54, 63
Cost estimate.....	66
Cracks.....	62
Customer-provided fuses.....	34

### D

Dangerous goods.....	24
Date of manufacture.....	11
Deceleration time	
- see also the softstart and softstop function	
.....	43
Declaration of conformity.....	9, 76
Declaration of conformity – China RoHS 2.	80
Declaration of decontamination.....	65, 67
Deformation of vessels (autoclaving).....	59
Dekontaminationsmittel.....	62
Density.....	11, 24
Desinfektion von Rotoren und Bechern.....	57
Different service life of rotors and accessories	
.....	26, 28, 71
Dimensions.....	31
Direct hazard to the life and health.....	16
Directive 2002/96/EC.....	67
Disinfectants.....	54
Disinfection of adapters.....	58
Disposal of the centrifuge.....	67
Disposal of the packaging.....	67

## Index

Documentation.....	9	Input fuse.....	68
<b>E</b>		Installation of a microhaematocrit rotor .....	37
Earth conductor check .....	29	Installation of a rotor .....	36
EC declaration of conformity .....	9, 76	Installation of accessories .....	38
Eco mode .....	45	Installation of rotors and accessories .....	36
EEPROM error.....	51	Installation site .....	33
Electrical connection .....	68	Intended use .....	8
Electrical safety.....	21	Interrupting a centrifugation run .....	40
Emergency lid release .....	49	Interrupting a deceleration process .....	40
Error correction .....	48	IP code .....	68
Error messages .....	48	<b>K</b>	
Explanation of the symbols and notes.....	16	Kinetic energy .....	11, 68
Explosive substances .....	23	Kontamination.....	62
Exposure to sunlight .....	54	Korrosion .....	62
<b>F</b>		<b>L</b>	
Fatal error .....	48	Layout of the centrifuge.....	10
F-gases label in compliance with the implementation regulation (EU) 2024/2729 .....	15	Leaks (accessories) .....	59
Filling quantity (refrigerant) .....	68	Lid cannot be opened .....	48
Fire preventions .....	23	Lid error .....	51
Form for the return of defective parts .....	65	Lid is not closed correctly.....	48
Functional and operating elements .....	10	Lid lock device .....	29
<b>G</b>		Lid lock has not released .....	48
General conditions .....	8	Lid lock is not closed correctly.....	48
General malfunctions .....	48	Lid seal sticks .....	48
General notes (maintenance and service)..	54	Long-term temperature resistance .....	54
Global warming potential (GWP).....	68	Lye.....	61
Gravitational field .....	37, 68	<b>M</b>	
Grease for load-bearing bolts.....	61	Mains power switch off.....	48
<b>H</b>		Mains voltage.....	21
Hazard warnings.....	8, 36, 38	Maintenance (condenser) .....	61
Heavy-duty grease for load-bearing bolts...	61	Maintenance and service .....	64
Highly corrosive substances .....	22	Maintenance of plastic accessories.....	63
Hochzyklus-Tragbolzenfett.....	62	Malfunction .....	48
<b>I</b>		Malfunctions and error correction.....	48
Imbalance .....	38	Manual release of the lid lock.....	49
Imbalance error.....	51	Manufacturer.....	68
Importance of the operating manual.....	8	Marking of the unit .....	15
Important information .....	16	Measures in the event of hazards and accidents .....	30
Inflammable substances .....	23	Mechanical safety .....	22
Informal safety instructions .....	20	Mode of operation .....	13
Initial start-up .....	35	Motor error .....	51
		Motor shaft.....	61
		Multiple carriers, cleaning and care.....	62

<b>N</b>	
Name plate .....	11
No indication on the display .....	48
No power in the mains supply .....	48
Noise level .....	68
Nominal voltage .....	11
Notes on safety and hazards .....	8
Notes on transport .....	31
<b>O</b>	
Online download of forms .....	66
Opening the lid.....	35
Operating personnel .....	20
Operating voltage.....	33
Operational safety.....	62
Overseas shipping .....	31
<b>P</b>	
Packaging .....	32
Parameter .....	37
Parameter error .....	51
Pathogenic substances .....	24
Performance data .....	68
Pick-up order .....	66
Potential hazard to the life and health .....	16
Potentially hazardous situation.....	16
Power consumption .....	11, 68
Power cord is not plugged in.....	48
Power supply .....	33
Precautions for the care of the accessories	62
Precooling program "Precool" .....	42, 47
Pressure (refrigerant).....	68
Pressure corrosion	
see corrosion .....	62
Pressure marks.....	62
Prevention of accidents.....	8
Problem description .....	65
Process error .....	51
Programm.....	47
Protection class .....	33, 68
<b>Q</b>	
Qualified electrician.....	19
Quick run .....	41
<b>R</b>	
Radioactive substances .....	24
Radius .....	14
RCF .....	40
Refrigerant.....	68
Refrigerant data .....	11, 68
Reinigen der Bohrungen von Winkelrotoren	
.....	62
Relative centrifugal force (RCF) .....	14, 40
Removing a rotor .....	36
Removing broken glass and metal dust from	
the rotor chamber .....	63
Requirements concerning the personnel....	19
Return of centrifuges, spare parts, or	
accessories .....	65
Return of defective parts .....	65
Rotor radii .....	70
Rotor selection .....	44
Rotor wrench .....	36
Rotoren und Becher (Desinfektion) .....	57
Rotors and accessories with a different	
service life .....	26, 28, 71
Rotors and accessories, service life .....	27
Rotors, cleaning and care .....	62
Runtime .....	41
<b>S</b>	
Safety area .....	24
Safety devices .....	29
Safety distance .....	21
Safety instructions.....	8, 36, 38
Safety instructions concerning the	
centrifugation process .....	24
Safety of rotors and accessories .....	25
Safety range .....	24, 33
Safety, chemical and biological .....	24
Safety, electrical .....	21
Safety, mechanical.....	22
Saving the current settings.....	47
Scope of supply .....	9
Serial number .....	11, 53
Serious incident (MD or IVD) Definition.....	18
Service contact .....	53
Service life .....	54
Service life of rotors and accessories.....	
.....	25, 26, 27, 28, 71
Service life of the accessories.....	59
Service life of the centrifuge .....	27
Set-up and connection .....	33

## Index

Short run .....	41	Temperature .....	42
Signs of corrosion .....	62	Temperature error .....	51
Softstart and softstop function .....	43	Temperature inside the rotor chamber .....	29
Solvent .....	55, 61	Temperature monitoring system .....	29
Solvents .....	25, 63	Temperature range .....	68
Spare part enquiries .....	53	Temperature value cannot be reached .....	48
Specialised personnel .....	20	Thermal stress .....	54
Speed .....	11, 14, 40, 68	Time range .....	68
Speedometer error .....	51	Toxic substances .....	24
Spincontrol Basic .....	39	Tragbolzenfett .....	62
Standards and regulations .....	9	Transport safety device .....	32
Standstill monitoring system .....	29	Type .....	11, 68
Starting a centrifugation run .....	40	Type of connection .....	33
Storage and transport .....	31	Type of the centrifuge .....	53
Storage conditions .....	31	<b>U</b>	
Structural changes .....	22	Units of protection class I .....	33
Supply voltage .....	33	User interface .....	39
Surface damage .....	62	UV radiation .....	33
Switching the centrifuge off .....	47	UV radiation .....	54
System check .....	29	<b>V</b>	
System error .....	51	Vents .....	33
<b>T</b>		<b>W</b>	
Table of error codes .....	51	Warranty and liability .....	8
Table of rotors and accessories with a different service life .....	26, 28, 71	Wear .....	64
Technical data .....	68	Weight .....	31
Technical documentation .....	69		