

SIEMENS

SINAMICS/SIMOTICS

SINAMICS V90, SIMOTICS S-1FL6

Operating Instructions

Preface

Safety instructions

1

General information

2

Mounting

3

Connecting

4

Commissioning

5

Basic operator panel (BOP)

6

Control functions

7

Safety Integrated function

8

Tuning

9

Parameters

10

Diagnostics

11



Appendix

A

Legal information

Warning notice system

This manual contains notices you have to observe in order to ensure your personal safety, as well as to prevent damage to property. The notices referring to your personal safety are highlighted in the manual by a safety alert symbol, notices referring only to property damage have no safety alert symbol. These notices shown below are graded according to the degree of danger.

| |
|--|
|  DANGER |
| indicates that death or severe personal injury will result if proper precautions are not taken. |
|  WARNING |
| indicates that death or severe personal injury may result if proper precautions are not taken. |
|  CAUTION |
| indicates that minor personal injury can result if proper precautions are not taken. |
| NOTICE |
| indicates that property damage can result if proper precautions are not taken. |

If more than one degree of danger is present, the warning notice representing the highest degree of danger will be used. A notice warning of injury to persons with a safety alert symbol may also include a warning relating to property damage.

Qualified Personnel

The product/system described in this documentation may be operated only by **personnel qualified** for the specific task in accordance with the relevant documentation, in particular its warning notices and safety instructions. Qualified personnel are those who, based on their training and experience, are capable of identifying risks and avoiding potential hazards when working with these products/systems.

Proper use of Siemens products

Note the following:

| |
|--|
|  WARNING |
| Siemens products may only be used for the applications described in the catalog and in the relevant technical documentation. If products and components from other manufacturers are used, these must be recommended or approved by Siemens. Proper transport, storage, installation, assembly, commissioning, operation and maintenance are required to ensure that the products operate safely and without any problems. The permissible ambient conditions must be complied with. The information in the relevant documentation must be observed. |

Trademarks

All names identified by ® are registered trademarks of Siemens AG. The remaining trademarks in this publication may be trademarks whose use by third parties for their own purposes could violate the rights of the owner.

Disclaimer of Liability

We have reviewed the contents of this publication to ensure consistency with the hardware and software described. Since variance cannot be precluded entirely, we cannot guarantee full consistency. However, the information in this publication is reviewed regularly and any necessary corrections are included in subsequent editions.

Preface

Documentation components

| Document | Content |
|---|---|
| Operating Instructions | (this manual) |
| Getting Started | Describes how to install, connect, operate, and perform basic commissioning of the SINAMICS V90 servo system. |
| Fan Replacement Guide | Describes how to replace fans for the SINAMICS V90 servo drives. |
| SIMOTICS S-1FL6 Servo Motors Installation Guide | Describes how to install the SIMOTICS S-1FL6 servo motor and relevant safety notices. |

Target group

This manual provides information about the SINAMICS V90 servo system for planners, operators, mechanical engineers, electrical engineers, commissioning engineers, and service engineers.

Technical support

| Country | Hotline |
|--|----------------------|
| China | +86 400 810 4288 |
| Germany | +49 (0) 911 895 7222 |
| Italy | +39 (02) 24362000 |
| India | +91 22 2760 0150 |
| Turkey | +90 (216) 4440747 |
| Further service contact information: Support contacts (http://support.automation.siemens.com/WW/view/en/16604999) | |

Table of contents

| | | |
|----------|--|-----------|
| | Preface | 3 |
| 1 | Safety instructions..... | 11 |
| 1.1 | General safety instructions | 11 |
| 1.2 | Safety instructions for electromagnetic fields (EMF) | 14 |
| 1.3 | Handling electrostatic sensitive devices (ESD) | 14 |
| 1.4 | Residual risks of power drive systems..... | 14 |
| 1.5 | Additional safety instructions | 16 |
| 2 | General information | 23 |
| 2.1 | Deliverables | 23 |
| 2.1.1 | Drive components | 23 |
| 2.1.2 | Motor components | 25 |
| 2.2 | Device combination..... | 27 |
| 2.3 | Product overview | 28 |
| 2.4 | System configuration | 30 |
| 2.5 | Accessories..... | 31 |
| 2.6 | Function list..... | 35 |
| 2.7 | Technical data..... | 37 |
| 2.7.1 | Technical data - servo drives | 37 |
| 2.7.2 | Technical data - servo motors | 39 |
| 2.7.3 | Technical data - cables | 44 |
| 3 | Mounting..... | 45 |
| 3.1 | Mounting the drive | 45 |
| 3.1.1 | Mounting orientation and clearance..... | 45 |
| 3.1.2 | Drill patterns and outline dimensions..... | 46 |
| 3.1.3 | Mounting the drive | 48 |
| 3.2 | Mounting the motor | 49 |
| 3.2.1 | Mounting orientation and dimensions | 49 |
| 3.2.2 | Mounting the motor | 52 |
| 4 | Connecting | 55 |
| 4.1 | System connection..... | 55 |
| 4.2 | Main circuit wirings..... | 57 |
| 4.2.1 | Line supply - L1, L2, L3..... | 57 |
| 4.2.2 | Motor power - U, V, W | 58 |
| 4.3 | Control/Status interface - X8..... | 59 |
| 4.3.1 | Digital inputs/outputs (DIs/DOs) | 60 |
| 4.3.1.1 | DIs..... | 61 |

| | | |
|----------|--|------------|
| 4.3.1.2 | DOs | 66 |
| 4.3.2 | Pulse train inputs/encoder outputs (PTIs/PTOs) | 69 |
| 4.3.2.1 | PTIs | 69 |
| 4.3.2.2 | PTOs | 70 |
| 4.3.3 | Analog inputs/outputs (AIs/AOs) | 70 |
| 4.3.3.1 | AIs | 70 |
| 4.3.3.2 | AOs | 71 |
| 4.3.4 | Standard application wirings (factory setting) | 73 |
| 4.3.4.1 | Pulse train input position control (PTI) | 73 |
| 4.3.4.2 | Internal position control (IPos) | 75 |
| 4.3.4.3 | Speed control (S) | 77 |
| 4.3.4.4 | Torque control (T) | 79 |
| 4.3.5 | Connection examples with PLCs | 81 |
| 4.3.5.1 | SIMATIC S7-200 SMART | 81 |
| 4.3.5.2 | SIMATIC S7-200 | 85 |
| 4.3.5.3 | SIMATIC S7-1200 | 89 |
| 4.4 | 24V power supply/STO - X6 | 93 |
| 4.5 | Encoder interface - X9 | 94 |
| 4.6 | External braking resistor - DCP, R1 | 97 |
| 4.7 | Motor holding brake - X7 | 97 |
| 4.8 | RS485 interface - X12 | 98 |
| 5 | Commissioning | 99 |
| 5.1 | Initial commissioning in JOG mode | 100 |
| 5.2 | Commissioning in pulse train position control mode (PTI) | 102 |
| 5.3 | Commissioning in internal position control mode (IPos) | 103 |
| 5.4 | Commissioning in speed control mode (S) | 105 |
| 5.5 | Commissioning in torque control mode (T) | 106 |
| 6 | Basic operator panel (BOP) | 109 |
| 6.1 | BOP overview | 109 |
| 6.1.1 | BOP display | 110 |
| 6.1.2 | Control buttons | 112 |
| 6.2 | Parameter structure | 113 |
| 6.3 | Actual status display | 114 |
| 6.4 | Basic operations | 115 |
| 6.4.1 | Editing parameters | 116 |
| 6.4.2 | Viewing parameters | 118 |
| 6.4.3 | Searching parameters in "P ALL" menu | 118 |
| 6.5 | Auxiliary functions | 119 |
| 6.5.1 | Jog | 120 |
| 6.5.2 | Saving parameters (RAM to ROM) | 121 |
| 6.5.3 | Setting parameters to default | 122 |
| 6.5.4 | Transferring data (drive to SD) | 122 |
| 6.5.5 | Transferring data (SD to drive) | 123 |
| 6.5.6 | Updating firmware | 124 |

| | | |
|----------|--|------------|
| 6.5.7 | Adjusting AI offsets | 124 |
| 6.5.8 | Adjusting an absolute encoder | 126 |
| 7 | Control functions | 127 |
| 7.1 | Compound controls | 127 |
| 7.2 | General functions | 128 |
| 7.2.1 | Servo ON | 128 |
| 7.2.2 | Direction of motor rotation | 129 |
| 7.2.3 | Over-travel | 130 |
| 7.2.4 | Motor holding brake | 131 |
| 7.2.5 | Stopping method at servo OFF | 134 |
| 7.3 | Pulse train input position control (PTI) | 135 |
| 7.3.1 | Selecting a setpoint pulse train input channel | 135 |
| 7.3.2 | Selecting a setpoint pulse train input form | 135 |
| 7.3.3 | In position (INP) | 136 |
| 7.3.4 | Smoothing function | 136 |
| 7.3.5 | Electronic gear ratio | 137 |
| 7.3.6 | Inhibiting pulse train input setpoint (P-TRG) | 141 |
| 7.3.7 | Speed limit | 142 |
| 7.3.8 | Torque limit | 143 |
| 7.3.9 | Clearing droop pulses (CLR) | 146 |
| 7.3.10 | Referencing (only for absolute encoder) | 146 |
| 7.3.11 | PTO function | 147 |
| 7.4 | Internal position control (IPos) | 148 |
| 7.4.1 | Setting mechanical system | 148 |
| 7.4.2 | Setting fixed position setpoint | 149 |
| 7.4.3 | Selecting a positioning mode - absolute/incremental | 151 |
| 7.4.4 | Configuring linear/modular axis | 152 |
| 7.4.5 | Backlash compensation | 152 |
| 7.4.6 | Referencing | 153 |
| 7.4.7 | Software position limit | 161 |
| 7.4.8 | Speed limit | 162 |
| 7.4.9 | Torque limit | 162 |
| 7.4.10 | Selecting a fixed position setpoint and starting positioning | 162 |
| 7.5 | Speed control (S) | 164 |
| 7.5.1 | Configuring speed setpoint | 164 |
| 7.5.1.1 | Speed control with external analog speed setpoint | 165 |
| 7.5.1.2 | Speed control with fixed speed setpoint | 166 |
| 7.5.2 | Direction and stop | 167 |
| 7.5.3 | Speed limit | 167 |
| 7.5.4 | Torque limit | 167 |
| 7.5.5 | Zero speed clamp | 167 |
| 7.5.6 | Ramp-function generator | 168 |
| 7.6 | Torque control (T) | 170 |
| 7.6.1 | 300% overload capacity | 170 |
| 7.6.2 | Torque setpoint | 171 |
| 7.6.2.1 | Torque control with external analog torque setpoint | 171 |
| 7.6.2.2 | Torque control with fixed torque setpoint | 172 |
| 7.6.3 | Direction and stop | 172 |
| 7.6.4 | Speed limit | 173 |

| | | |
|----------|--|------------|
| 7.7 | Absolute position system | 173 |
| 7.7.1 | USS communication telegram | 174 |
| 7.7.2 | Transmitting sequence for the absolute position data | 174 |
| 8 | Safety Integrated function | 177 |
| 8.1 | Standards and regulations | 177 |
| 8.1.1 | General information | 177 |
| 8.1.1.1 | Aims | 177 |
| 8.1.1.2 | Functional safety | 178 |
| 8.1.2 | Safety of machinery in Europe | 178 |
| 8.1.2.1 | Machinery Directive | 179 |
| 8.1.2.2 | Harmonized European Standards | 179 |
| 8.1.2.3 | Standards for implementing safety-related controllers | 181 |
| 8.1.2.4 | DIN EN ISO 13849-1 (replaces EN 954-1) | 182 |
| 8.1.2.5 | EN 62061 | 183 |
| 8.1.2.6 | Series of standards EN 61508 (VDE 0803) | 184 |
| 8.1.2.7 | Risk analysis/assessment | 185 |
| 8.1.2.8 | Risk reduction | 186 |
| 8.1.2.9 | Residual risk | 187 |
| 8.1.3 | Machine safety in the USA | 187 |
| 8.1.3.1 | Minimum requirements of the OSHA | 187 |
| 8.1.3.2 | NRTL listing | 188 |
| 8.1.3.3 | NFPA 79 | 188 |
| 8.1.3.4 | ANSI B11 | 189 |
| 8.1.4 | Machine safety in Japan | 190 |
| 8.1.5 | Equipment regulations | 190 |
| 8.2 | General information about SINAMICS Safety Integrated | 190 |
| 8.3 | System features | 191 |
| 8.3.1 | Certification | 191 |
| 8.3.2 | Safety instructions | 191 |
| 8.3.3 | Probability of failure of the safety function (PHF value) | 192 |
| 8.3.4 | Response time | 193 |
| 8.3.5 | Residual risk | 193 |
| 8.4 | Safety Integrated basic functions | 193 |
| 8.4.1 | Safe Torque Off (STO) | 193 |
| 8.4.2 | Forced dormant error detection | 195 |
| 9 | Tuning | 197 |
| 9.1 | Controller overview | 197 |
| 9.2 | First time commissioning mode | 199 |
| 9.2.1 | Basic tuning procedure | 200 |
| 9.2.2 | Configuration of dynamic factor | 200 |
| 9.3 | Real-time auto tuning | 201 |
| 9.4 | Manual tuning | 202 |
| 9.5 | Resonance suppression | 204 |
| 9.6 | Gain switching | 207 |
| 9.6.1 | Gain switching using an external digital input signal (G-CHANGE) | 208 |
| 9.6.2 | Gain switching using position deviation | 209 |

| | | |
|-----------|--|------------|
| 9.6.3 | Gain switching using position setpoint frequency | 210 |
| 9.6.4 | Gain switching using actual speed | 211 |
| 9.7 | PI/P switching | 211 |
| 9.7.1 | PI/P switching using torque setpoint..... | 214 |
| 9.7.2 | PI/P switching using an external digital input signal (G-CHANGE) | 214 |
| 9.7.3 | PI/P switching using speed setpoint | 215 |
| 9.7.4 | PI/P switching using acceleration setpoint | 216 |
| 9.7.5 | PI/P switching using pulse deviation..... | 217 |
| 10 | Parameters | 219 |
| 10.1 | Overview | 219 |
| 10.2 | Parameter list..... | 221 |
| 11 | Diagnostics | 251 |
| 11.1 | Overview | 251 |
| 11.2 | List of faults and alarms | 255 |
| A | Appendix..... | 271 |
| A.1 | Order numbers..... | 271 |
| A.2 | Assembly of cable connectors on the motor side | 274 |
| A.3 | Assembly of cable terminals on the drive side | 276 |
| A.4 | Motor selection..... | 278 |
| A.4.1 | Selection procedure | 278 |
| A.4.2 | Parameter description..... | 279 |
| A.4.3 | Selection examples | 281 |
| A.5 | Replacing fans | 282 |
| | Index..... | 285 |

Safety instructions

1.1 General safety instructions



DANGER

Danger to life when live parts are touched

Death or serious injury can result when live parts are touched.

- Only work on electrical devices when you are qualified for this job.
- Always observe the country-specific safety rules.

Generally, six steps apply when establishing safety:

1. Prepare for shutdown and notify all those who will be affected by the procedure.
2. Disconnect the machine from the supply.
 - Switch off the machine.
 - Wait until the discharge time specified on the warning labels has elapsed.
 - Check that it really is in a no-voltage condition, from phase conductor to phase conductor and phase conductor to protective conductor.
 - Check whether the existing auxiliary supply circuits are de-energized.
 - Ensure that the motors cannot move.
3. Identify all other hazardous energy sources, e.g. compressed air, hydraulic systems, water.
4. Isolate or neutralize all hazardous energy sources, e.g. by closing switches, grounding or short-circuiting or closing valves.
5. Secure the energy sources against switching on again.
6. Make sure that the machine is completely locked ... and that you have the right machine. After you have completed the work, restore the operational readiness in the inverse sequence.



WARNING

Danger to life through a hazardous voltage when connecting an unsuitable power supply

Death or serious injury can result when live parts are touched in the event of a fault.

- Only use power supplies that provide SELV (Safety Extra Low Voltage) or PELV- (Protective Extra Low Voltage) output voltages for all connections and terminals of the electronics modules.



⚠ WARNING

Danger to life when live parts are touched on damaged devices

Improper handling of devices can cause damage.

Hazardous voltages can be present at the housing or exposed components on damaged devices.

- Ensure compliance with the limit values specified in the technical data during transport, storage and operation.
- Do not use any damaged devices.
- Protect the components against conductive pollution, e.g., by installing them in a control cabinet with IP54 degree of protection according to IEC 60529 or NEMA 12. Provided conductive pollution can be prevented at the installation site, the degree of protection for the cabinet can be decreased accordingly.

⚠ WARNING

Danger of fire spreading due to inadequate housing

Fire and smoke development can cause severe personal injury or material damage.

- Install devices without a protective housing in a metal control cabinet (or protect the device by another equivalent measure) in such a way that contact with fire inside and outside the device is prevented.
- Additionally, select the installation site so that an uncontrolled spreading of smoke can be avoided in the case of a fire.
- Ensure that smoke can escape via designated paths.

⚠ WARNING

Danger to life through unexpected movement of machines when using mobile wireless devices or mobile phones

Using mobile wireless devices or mobile phones with a transmitter power > 1 W closer than approx. 2 m to the components may cause the devices to malfunction and influence the functional safety of machines, therefore putting people at risk or causing material damage.

- Switch the wireless devices or mobile phones off in the immediate vicinity of the components.

⚠ WARNING

Fire hazard for the motor due to overload of the insulation

There is a greater load on the motor insulation through a ground fault in an IT system. A possible result is the failure of the insulation with a risk for personnel through smoke development and fire.

- Use a monitoring device that signals an insulation fault.
- Correct the fault as quickly as possible so the motor insulation is not overloaded.

⚠ WARNING**Fire hazard due to overheating because of inadequate ventilation clearances**

Inadequate ventilation clearances can cause overheating with a risk for personnel through smoke development and fire. This can also result in increased downtime and reduced service lives for devices / systems.

- Ensure compliance with the specified minimum clearance as ventilation clearance for the respective component. They can be found in the dimension drawings or in the "Product-specific safety instructions" at the start of the respective section.

**⚠ WARNING****Danger to life through electric shock due to unconnected cable shields**

Hazardous touch voltages can occur through capacitive cross-coupling due to unconnected cable shields.

- Connect cable shields and unused conductors of power cables (e.g., brake conductors) at least on one side to the grounded housing potential.

⚠ WARNING**Danger to life when safety functions are inactive**

Safety functions that are inactive or that have not been adjusted accordingly can cause operational faults on machines that could lead to serious injury or death.

- Observe the information in the appropriate product documentation before commissioning.
- Carry out a safety inspection for functions relevant to safety on the entire system, including all safety-related components.
- Ensure that the safety functions used in your drives and automation tasks are adjusted and activated through appropriate parameterizing.
- Run a function test.
- Only put your plant into live operation once you have guaranteed that the functions relevant to safety are running correctly.

Note**Important safety notices for safety functions**

If you want to use safety functions, you must observe the safety notices in the safety manuals.

1.2 Safety instructions for electromagnetic fields (EMF)



| |
|---|
| ⚠ WARNING |
| Danger to life from electromagnetic fields |
| Electromagnetic fields (EMF) are generated by the operation of electrical power equipment such as transformers, converters or motors. |
| People with pacemakers or implants are at a special risk in the immediate vicinity of these devices/systems. |
| <ul style="list-style-type: none">• Keep a distance of at least 2 m. |

1.3 Handling electrostatic sensitive devices (ESD)

Electrostatic sensitive devices (ESD) are individual components, integrated circuits, modules or devices that may be damaged by either electric fields or electrostatic discharge.



| |
|---|
| NOTICE |
| Damage through electric fields or electrostatic discharge |
| Electric fields or electrostatic discharge can cause malfunctions through damaged individual components, integrated circuits, modules or devices. |
| <ul style="list-style-type: none">• Only pack, store, transport and send electronic components, modules or devices in their original packaging or in other suitable materials, e.g. conductive foam rubber or aluminum foil.• Only touch components, modules and devices when you are grounded by one of the following methods:<ul style="list-style-type: none">– Wearing an ESD wrist strap– Wearing ESD shoes or ESD grounding straps in ESD areas with conductive flooring• Only place electronic components, modules or devices on conductive surfaces (table with ESD surface, conductive ESD foam, ESD packaging, ESD transport container). |

1.4 Residual risks of power drive systems

Residual risks of power drive systems

The control and drive components of a drive system are approved for industrial and commercial use in industrial line supplies. Their use in public line supplies requires a different configuration and/or additional measures.

These components may only be operated in closed housings or in higher-level control cabinets with protective covers that are closed, and when all of the protective devices are used.

These components may only be handled by qualified and trained technical personnel who are knowledgeable and observe all of the safety instructions on the components and in the associated technical user documentation.

When assessing the machine's risk in accordance with the respective local regulations (e.g., EC Machinery Directive), the machine manufacturer must take into account the following residual risks emanating from the control and drive components of a drive system:

1. Unintentional movements of driven machine components during commissioning, operation, maintenance, and repairs caused by, for example:
 - Hardware defects and/or software errors in the sensors, controllers, actuators, and connection technology
 - Response times of the controller and drive
 - Operating and/or surrounding conditions outside of the specification
 - Condensation / conductive contamination
 - Parameterization, programming, cabling, and installation errors
 - Use of radio devices / cellular phones in the immediate vicinity of the controller
 - External influences / damage
2. In the event of a fault, exceptionally high temperatures, including an open fire, as well as emissions of light, noise, particles, gases, etc. can occur inside and outside the inverter, e.g.:
 - Component malfunctions
 - Software errors
 - Operating and/or surrounding conditions outside of the specification
 - External influences / damage

Inverters of the Open Type / IP20 degree of protection must be installed in a metal control cabinet (or protected by another equivalent measure) such that the contact with fire inside and outside the inverter is not possible.
3. Hazardous shock voltages caused by, for example:
 - Component malfunctions
 - Influence of electrostatic charging
 - Induction of voltages in moving motors
 - Operating and/or surrounding conditions outside of the specification
 - Condensation / conductive contamination
 - External influences / damage

1.5 Additional safety instructions

- 4. Electrical, magnetic and electromagnetic fields generated in operation that can pose a risk to people with a pacemaker, implants or metal replacement joints, etc. if they are too close.
- 5. Release of environmental pollutants or emissions as a result of improper operation of the system and/or failure to dispose of components safely and correctly.

Note

The components must be protected against conductive contamination (e.g. by installing them in a control cabinet with degree of protection IP54 according to IEC 60529 or NEMA 12).

Assuming that conductive contamination at the installation site can definitely be excluded, a lower degree of cabinet protection may be permitted.

For more information about residual risks of the components in a drive system, see the relevant sections in the technical user documentation.

1.5 Additional safety instructions

Delivery check

Note

Intact deliverables

Deliverables received must be intact. It's not permissible to put a damaged unit into use.

Transport and storage

| |
|---|
| NOTICE |
| Property loss Notify Siemens service personnel immediately of any damage discovered after delivery. If the equipment is put into storage, keep it in a dry, dust-free, and low-vibration environment. The storage temperature ranges from -40 °C to +70 °C. Otherwise you will suffer property loss. |

Mechanical installation

WARNING

Death or severe personal injury from harsh installation environment

A harsh installation environment will jeopardize personal safety and equipment. Therefore,

- Do not install the drive and the motor in an area subject to inflammables or combustibles, water or corrosion hazards.
- Do not install the drive and the motor in an area where it is likely to be exposed to constant vibrations or physical shocks.
- Do not keep the drive exposed to strong electro-magnetic interference.
- Make sure that no foreign body (e.g., chips of wood or metal, dust, paper, etc.) can be seen inside the drive or on the heat sink of the drive.
- Make sure that the drive is installed in an electrical cabinet with an adequate degree of protection.

Note

Mounting clearance

To guarantee good heat dissipation and ease of cabling, keep sufficient clearance between drives, one drive and another device/inner wall of the cabinet.

Note

Screw tightening

Make sure you fix the screw to the terminal door of the drive after you have completed the installation work.

Electrical installation



DANGER

Death or severe personal injury from electrical shock

The earth leakage current for the drive can be greater than AC 3.5 mA, which may cause death or severe personal injury due to electrical shock.

A fixed earth connection is required to eliminate the dangerous leakage current. In addition, the minimum size of the protective earth conductor shall comply with the local safety regulations for high leakage current equipment.

 **WARNING**

Personal injury and damage to property from improper connections

Improper connections have high risks of electrical shock and short circuit, which will jeopardize personal safety and equipment.

- The drive must be directly connected with the motor. It is not permissible to connect a capacitor, inductor or filter between them.
- Make sure that all connections are correct and reliable, the drive and the motor are well grounded.
- The line supply voltage must be within the allowable range (refer to the drive rating plate). Never connect the line supply cable to the motor terminals U, V, W or connect the motor power cable to the line input terminals L1, L2, L3.
- Never wire up the U, V, W terminals in an interchanged phase sequence.
- If the CE marking for cables is mandatory in some cases, the motor power cable, line supply cable and brake cable used must all be shielded cables.
- For terminal box connection, make sure that the clearances in air between non-insulated live parts are at least 5.5 mm.
- Route signal cables and power cables separately in different cable conduits. The signal cables shall be at least 10 cm away from the power cables.
- Cables connected may not come into contact with rotating mechanical parts.

 **CAUTION**

Personal injury and damage to property from inadequate protection

Inadequate protection may cause minor personal injury or damage to property.

- The drive must have been disconnected from the power supply for at least five minutes before you perform any wiring to it.
- Check that the equipment is dead!
- Make sure that the drive and the motor are properly grounded.
- Route a second PE conductor with the cross section of the supply system lead in parallel to the protective earth via separate terminals or use a copper protective earth conductor with a cross section of 10 mm².
- Terminals for equipotential bondings that exist in addition to terminals for PE conductors must not be used for looping-through the PE conductors.
- To ensure protective separation, an isolating transformer must be used for the 380 V AC line supply system.

NOTICE

Damage to property from incorrect input voltage

Incorrect input voltage will cause severe damage to the drive.

It is recommended that the actual input voltage should not be greater than 110% of the rated voltage or smaller than 75%.

Note**STO wiring**

The safe torque off (STO) function can stop a motor using safety relays without involving any upper level control. It is disabled in the factory configuration by short-circuiting the STO terminals. The safety function of the servo drive is SIL 2 (EN61800-5-2). Connect the STO terminals as the actual requirements.

Commissioning/Operation **CAUTION****Burns from hot surface**

The operating temperature of drive base-plate and heat sink is higher than 65 °C, and the surface temperature of the motor may reach up to 80 °C. The hot surface may burn your hands.

Do not touch the motor or the heat sink of the drive during operation or within a certain period since power disconnection.

NOTICE**Shortening the service life of motor brake**

The motor brake is used for holding purpose only. Frequent emergency stops with the motor brake will shorten its service life.

Unless absolutely necessary, do not apply the motor brake as an emergency stop or deceleration mechanism.

NOTICE**Damage to the equipment from frequent power-on/off**

Frequent power-on/off will cause damage to the drive.

Do not switch on/off the power frequently.

Note**Voltage requirement**

Before switching the power on, make sure that the drive system has been reliably installed and connected, and the line supply voltage is within the allowable range.

Note**Drive functioning interfered by use of radio devices**

Some environmental factors may result in power derating, e.g. altitude and surrounding temperature. In this case, the drive cannot work normally.

Environmental factors must be taken into account during commissioning or operation.

Troubleshooting



WARNING

Drive remaining charged

The drive may remain charged in a short period after it is powered off.

Touching terminals or disassembling cables may cause minor injury due to electrical shock.

Do not touch terminals or disassemble cables until the drive system has been disconnected for at least five minutes.

WARNING

Personal injury due to unexpected restart

The machine might unexpectedly restart after the power supply that was suddenly switched off is switched on again. Touching the machine at this time may cause personal injury.

Do not approach the machine after the power supply is switched on again.

Disposal

Note

Equipment disposal

Disposal of the equipment must be made in accordance with the regulations of the competent environmental protection administration on the disposal of electronic wastes.

Certification

WARNING

Requirements for United States / Canadian installations (UL/cUL)

Suitable for use on a circuit capable of delivering not more than 65000 rms Symmetrical Amperes, 480 VAC maximum, when protected by UL/cUL-certified Class J fuses only. For each frame size AA, A, B, and C, use class 1 75 °C copper wire only.

This equipment is capable of providing internal motor overload protection according to UL508C.

For Canadian (cUL) installations the drive mains supply must be fitted with any external recommended suppressor with the following features:

- Surge-protective devices; device shall be a Listed Surge-protective device (Category code VZCA and VZCA7)
- Rated nominal voltage 480/277 VAC, 50/60 Hz, 3-phase
- Clamping voltage VPR = 2000 V, IN = 3 kA min, MCOV = 508 VAC, SCCR = 65 kA
- Suitable for Type 2 SPD application
- Clamping shall be provided between phases and also between phase and ground

 WARNING**Harms to human health from electromagnetic radiation**

This product may cause high-frequency electromagnetic radiation, which will affect human health. Therefore, in a residential environment, make sure that necessary suppression measures are taken.

Note**EMC instructions**





- To comply with the EMC standards, all cables connected with the SINAMICS V90 system must be shielded cables, which include cables from the line supply to the line filter and from the line filter to the SINAMICS V90 drive.
- The SINAMICS V90 drives have been tested in accordance with the emission requirements of the category of C2 (domestic) environment. The conducted emissions and radiated emissions are complied with the standard of EN 55011 and reached Class A.
- In a residential environment, this product can cause high-frequency interferences that may necessitate suppression measures.
- For a radiated emission test, an external AC filter (between the 380 V AC power supply and the drive) will be used to meet the EMC requirement and the drive will be installed inside the shielded metallic chamber, other parts of the motion control system (including the PLC, DC power supply, spindle drive, motor) will be put inside the shielded chamber.
- For a conductive emission test, an external AC filter (between the 380 V AC power supply and the drive) will be used to meet the EMC requirement.
- For the radiated emission and conductive emission test, the length of the line supply cable between the line filter and the drive must be shorter than 1 m.

Information regarding non-Siemens products**Note****Non-Siemens products**

This document contains recommendations relating to non-Siemens products. Non-Siemens products whose fundamental suitability is familiar to us. It goes without saying that equivalent products from other manufacturers may be used. Our recommendations are to be seen as helpful information, not as requirements or dictates. We cannot accept any liability for the quality and properties/features of non-Siemens products.

Warning labels

Warning labels attached to the motor or drive have the following meanings:





| Symbol | Description |
|--|---|
|  | Risk of electric shock Do not touch any terminals or disassemble cables until the drive has been disconnected from power for at least five minutes. |
|  | Caution Pay attention to the information given on the rating plate and operating instructions. For more information, refer to this manual. |
|  | Hot surface Do not touch the heatsink of the drive during operation or within a certain period since power disconnection because its surface temperature may reach up to 65 °C. |
|  | No knocking at the shaft Do not exert any shock at the shaft end; otherwise, the shaft may be damaged. |
|  | Protective conductor terminal |

General information

2.1 Deliverables

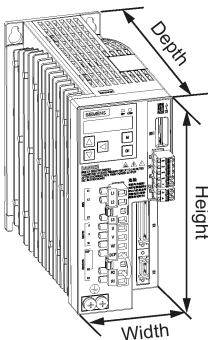
2.1.1 Drive components

When unpacking the drive package, check whether the following components are included.

| Component | Illustration | Rated motor power (kW) | Outline dimension (Width x Height x Depth, mm) | Frame size |
|--------------------------|---|---|--|------------|
| SINAMICS V90 servo drive |  | • 0.4 | 60 x 180 x 200 | FSAA |
| | | • 0.75 | 80 x 180 x 200 | FSA |
| | | • 0.75/1.0 | | |
| | | • 1.5/1.75 | 100 x 180 x 220 | FSB |
| | | • 2.0/2.5 | | |
| | | • 3.5 | 140 x 260 x 240 | FSC |
| | | • 5.0 | | |
| | | • 7.0 | | |
| Connectors |  | FSAA/FSA: 4 pieces FSB/FSC: 2 pieces | | |
| Shielding plate |  | for FSAA and FSA | | |
| |  | for FSB and FSC | | |
| Cable clamp |  | FSAA/FSA: None FSB/FSC: 1 piece | | |
| User documentation | Getting Started | English-Chinese bilingual version | | |

Drive rating plate

SIEMENS

- ① • SINAMICS V90
- ② • INPUT: 3AC 380-480V 1.5A 50/60Hz
- ③ • OUTPUT: 3AC 0-input V 1.2A 0-330Hz
- ④ • IP CLASS: IP20 MOTOR: 0.4kW FS: 02
- ⑤ • 1P 6SL3210-5FE10-4UA0
- ⑥ • S ZVXXXXXXXXXXXX
- ⑦ • SNC-A5E03662016

IND. CONT. EQ. LISTED
4TR2

Refer to user manual

Siemens Numerical Control Ltd.
No. 18 Siemens Rd, Jiangning Dev. Zone, Nanjing, 211100, P.R.C

6SL3210-5FE10-4UA0

Mains voltage
E: 3 phase 380~480 VAC

Supported motor power
10-4: 0.4 kW
10-8: 0.75 kW
11-0: 0.75/1.0 kW
11-5: 1.5/1.75 kW
12-0: 2.0/2.5 kW
13-5: 3.5 kW
15-0: 5.0 kW
17-0: 7.0 kW

| | | | |
|---|-------------------|---|-----------------------|
| ① | Drive name | ⑤ | Order number |
| ② | Power input | ⑥ | Product serial number |
| ③ | Power output | ⑦ | Part number |
| ④ | Rated motor power | | |

2.1.2 Motor components

When unpacking the motor package, check whether the following components are included.

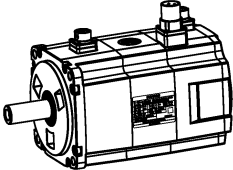
| Component | Illustration | Rated torque (Nm) | Shaft height (mm) |
|-----------------------------|---|--|-------------------|
| SIMOTICS S-1FL6 servo motor |  | <ul style="list-style-type: none"> • 1.27 • 2.39 | 45 |
| | | <ul style="list-style-type: none"> • 3.58 • 4.78 • 7.16 • 8.36 • 9.55 | 65 |
| | | <ul style="list-style-type: none"> • 11.90 • 16.70 • 23.90 • 33.40 | 90 |
| User documentation | SIMOTICS S-1FL6 Servo Motors Installation Guide | | |

Motor rating plate

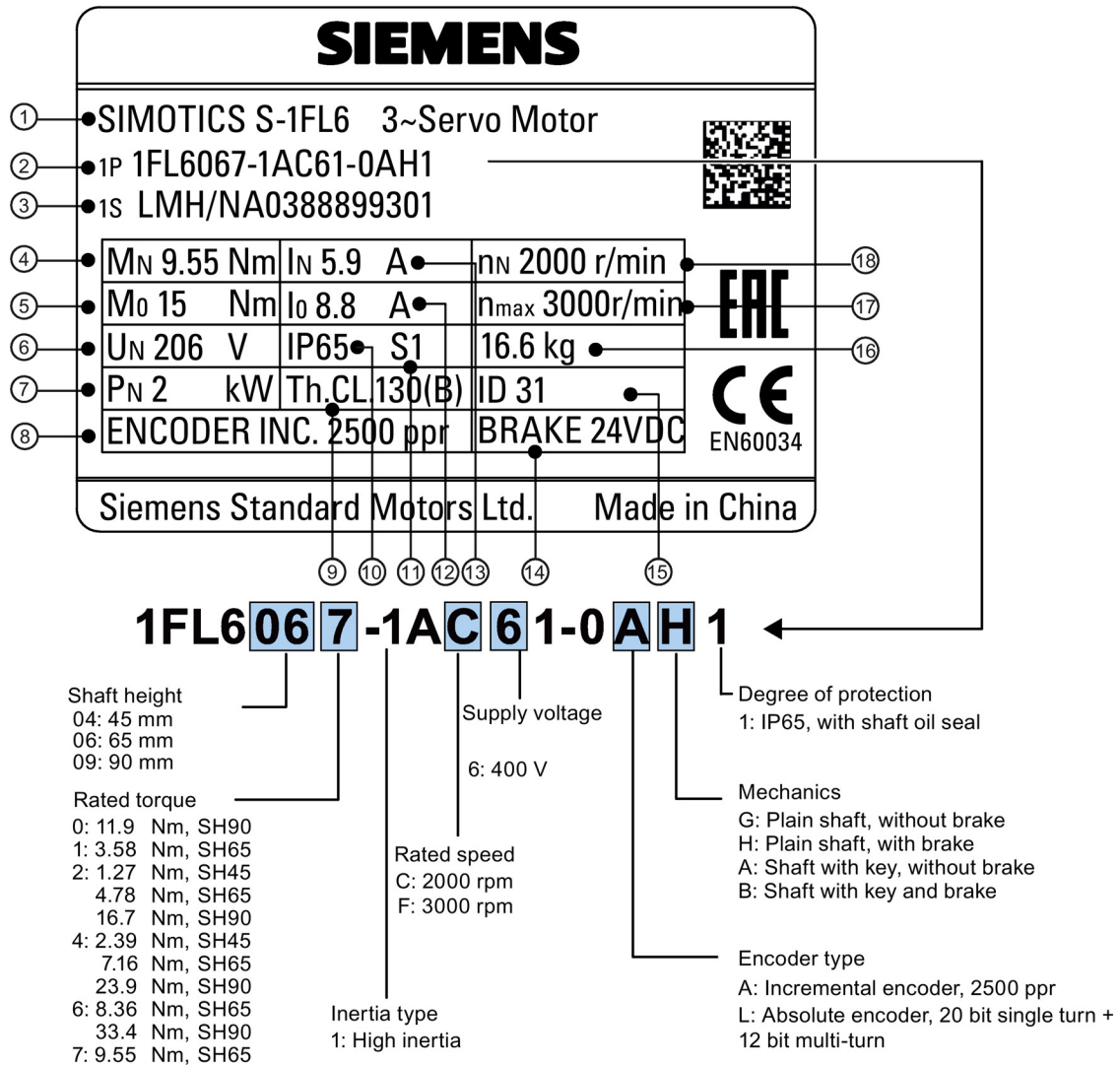

| | | | | | |
|---|---------------|---|-----------------------------|---|---------------|
| ① | Motor type | ⑦ | Rated power | ⑬ | Rated current |
| ② | Order number | ⑧ | Encoder type and resolution | ⑭ | Holding brake |
| ③ | Serial number | ⑨ | Thermal class | ⑮ | Motor ID |
| ④ | Rated torque | ⑩ | Degree of protection | ⑯ | Weight |
| ⑤ | Stall torque | ⑪ | Motor operating mode | ⑰ | Maximum speed |
| ⑥ | Rated voltage | ⑫ | Stall current | ⑱ | Rated speed |

2.2 Device combination

The table below shows the combination of SINAMICS V90 servo drives and SIMOTICS S-1FL6 servo motors.

| SIMOTICS S-1FL6 servo motor | | | | | SINAMICS V90 servo drive | |
|-----------------------------|------------------|-------------------|-------------------|----------------------------|--------------------------|--------------------|
| Rated torque (Nm) | Rated power (kW) | Rated speed (rpm) | Shaft height (mm) | Order number ¹⁾ | Order number | Frame size |
| 1.27 | 0.4 | 3000 | 45 | 1FL6042-1AF61-0□□1 | 6SL3210-5FE10-4UA0 | FSA |
| 2.39 | 0.75 | 3000 | 45 | 1FL6044-1AF61-0□□1 | 6SL3210-5FE10-8UA0 | FSA |
| 3.58 | 0.75 | 2000 | 65 | 1FL6061-1AC61-0□□1 | 6SL3210-5FE11-0UA0 | |
| 4.78 | 1.0 | 2000 | 65 | 1FL6062-1AC61-0□□1 | | 6SL3210-5FE11-5UA0 |
| 7.16 | 1.5 | 2000 | 65 | 1FL6064-1AC61-0□□1 | | |
| 8.36 | 1.75 | 2000 | 65 | 1FL6066-1AC61-0□□1 | 6SL3210-5FE12-0UA0 | |
| 9.55 | 2.0 | 2000 | 65 | 1FL6067-1AC61-0□□1 | | |
| 11.9 | 2.5 | 2000 | 90 | 1FL6090-1AC61-0□□1 | 6SL3210-5FE13-5UA0 | FSC |
| 16.7 | 3.5 | 2000 | 90 | 1FL6092-1AC61-0□□1 | | |
| 23.9 | 5.0 | 2000 | 90 | 1FL6094-1AC61-0□□1 | 6SL3210-5FE15-0UA0 | |
| 33.4 | 7.0 | 2000 | 90 | 1FL6096-1AC61-0□□1 | | |

¹⁾ The symbol □□ in the motor order numbers is for optional configurations (encoder type and mechanics). Refer to the motor rating plate explanation in Motor components (Page 25) for detailed information.

2.3 Product overview

SINAMICS V90 servo drives

- FSAA and FSA

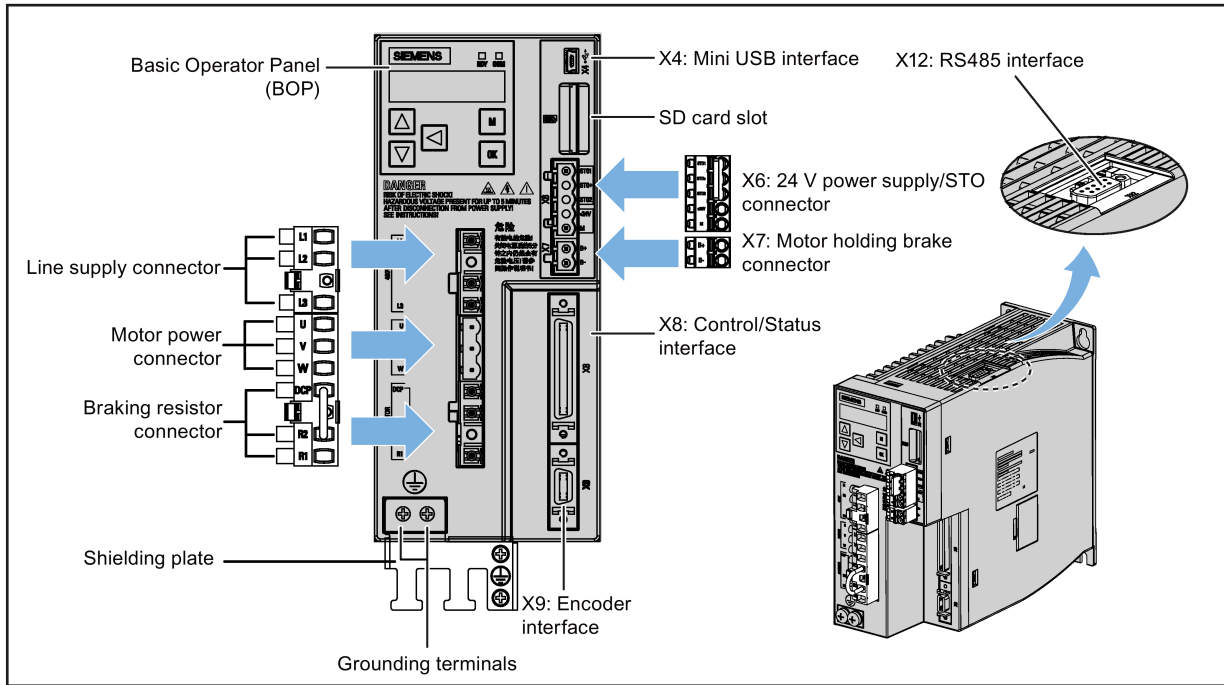

- FSB and FSC

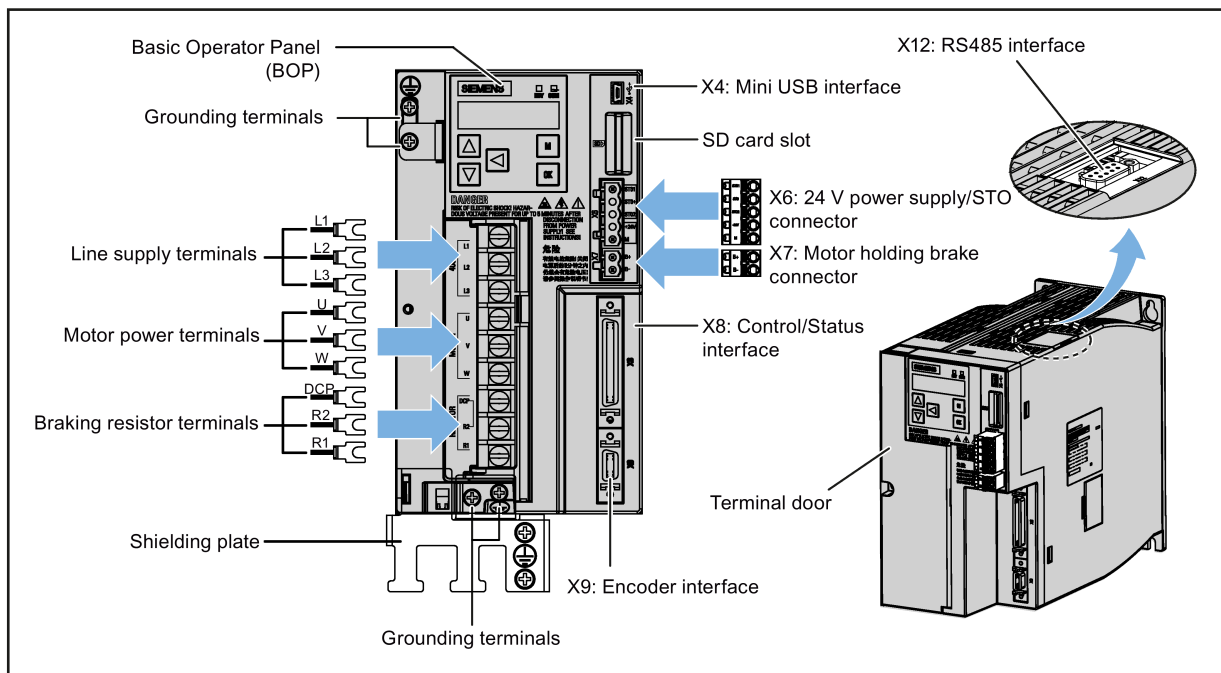

SIMOTICS S-1FL6 servo motors

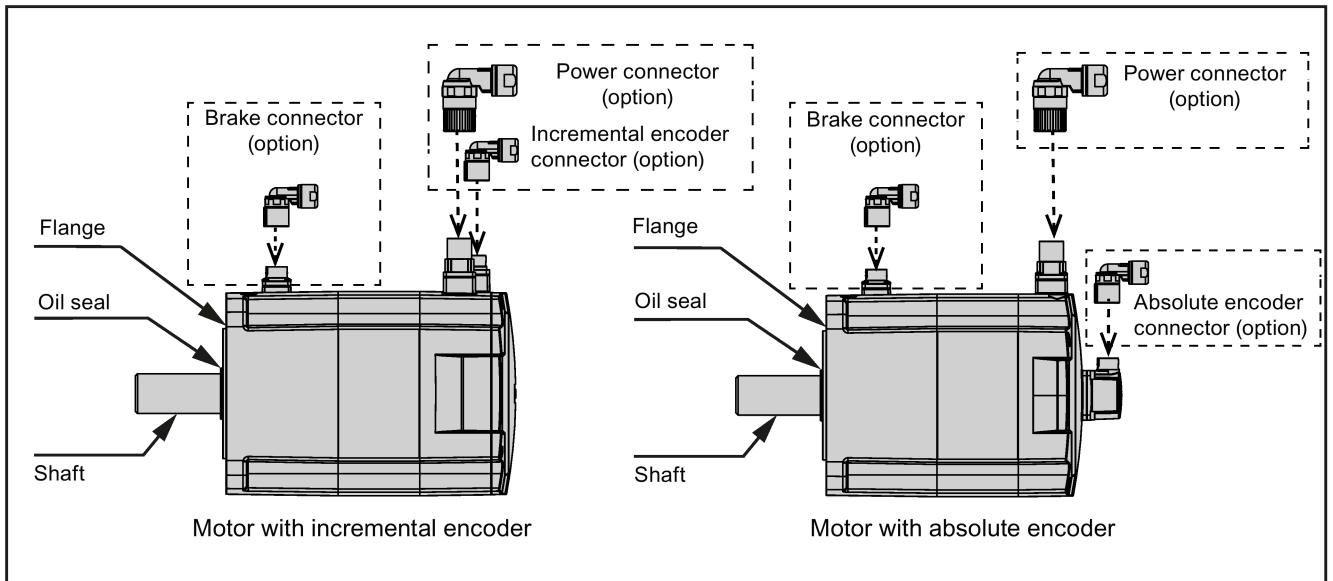

2.4 System configuration

The SINAMICS V90 servo drive is integrated with digital input/output interface, pulse train interface and analog interface. It can be connected either to a Siemens controller like S7-200, S7-1200 or S7-200 SMART, or to a third-party controller. Absolute position information can be read from the servo drive by the PLC via RS485 port.

A configuration software tool, SINAMICS V-ASSISTANT, can be installed on a PC. The PC can communicate with SINAMICS V90 servo drive with a USB cable for performing parameter settings, trial run, status display monitoring, gain adjustments, and so on.

The following illustration shows an example of the SINAMICS V90 servo system configuration:

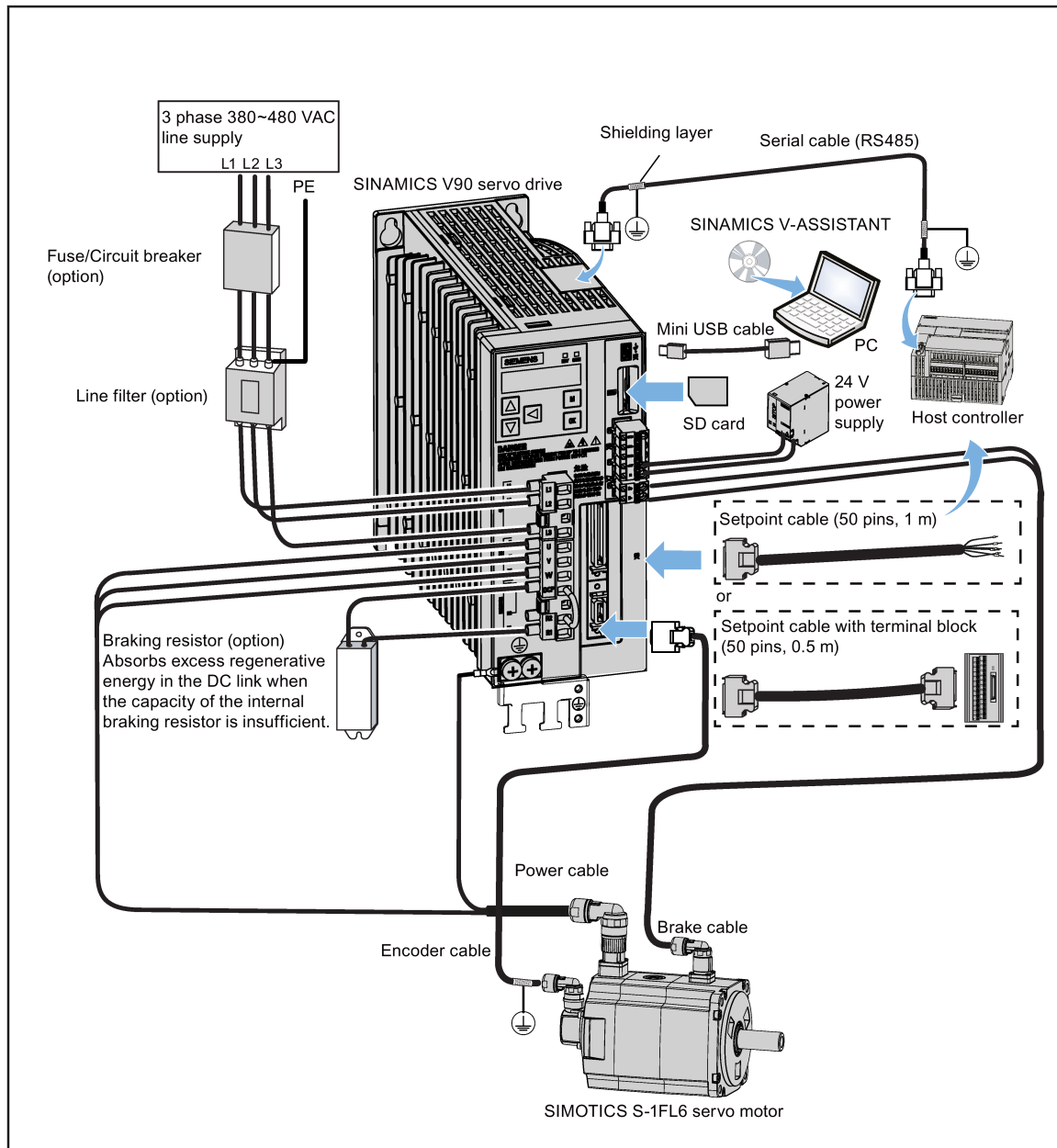

2.5 Accessories

Cables and connectors

The illustration below shows cables between the drive and the motor and configurable cable connectors:

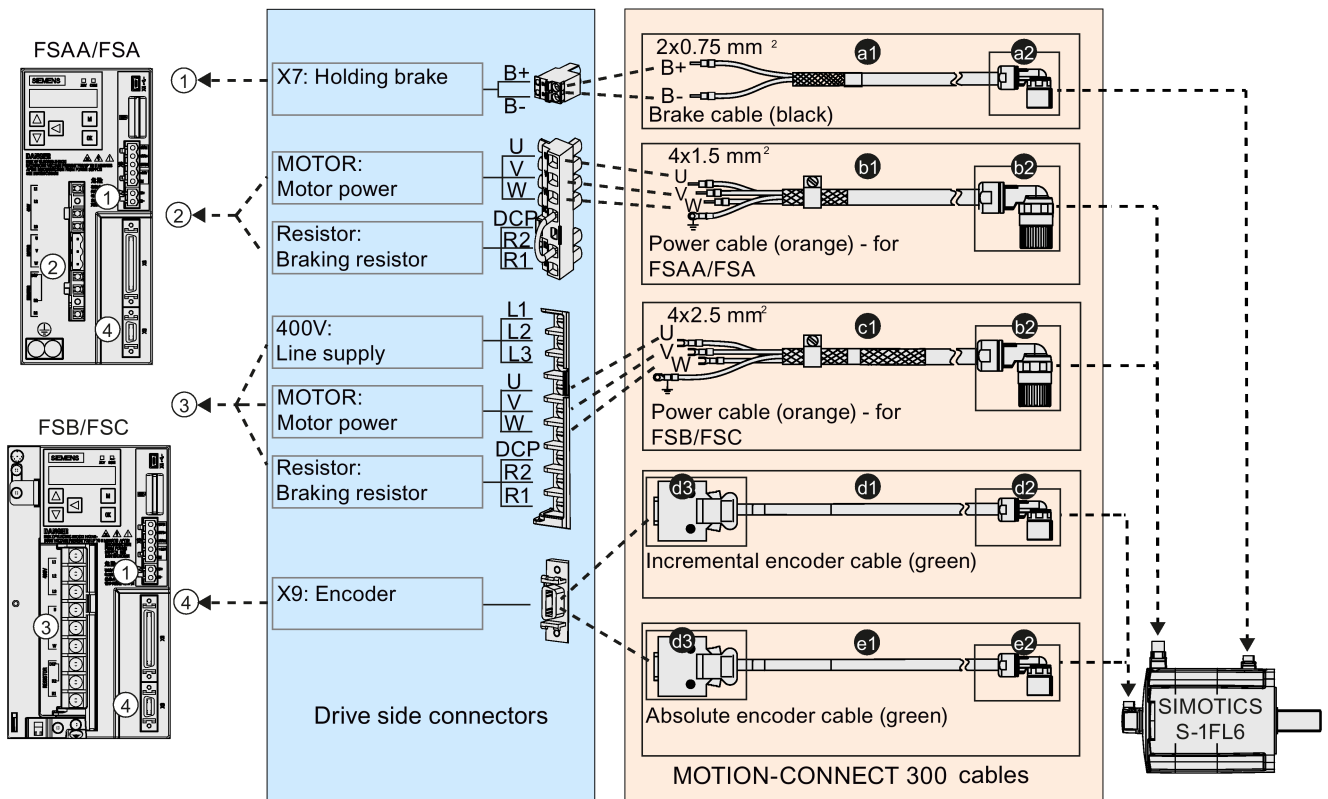

You can select cables and connectors according to the table below:

| MOTION-CONNECT 300 cable | | | Cable connector (motor side) | | Cable connector (drive side) | |
|---------------------------------|--------|--------------------------|---------------------------------|--------------------------|---------------------------------|--------------------------|
| Type | Length | Order No. 6FX3002-... | Type | Order No. 6FX2003-... | Type | Order No. 6FX2003-... |
| Brake cable (a1) | 3 m | 5BL02-1AD0 | Brake connector (a2) | 0LL51 | - | - |
| | 5 m | 5BL02-1AF0 | | | | |
| | 7 m | 5BL02-1AH0 | | | | |
| | 10 m | 5BL02-1BA0 | | | | |
| | 20 m | 5BL02-1CA0 | | | | |
| Power cable for FSA/FSA (b1) | 3 m | 5CL01-1AD0 | Power connector (b2) | 0LL11 | - | - |
| | 5 m | 5CL01-1AF0 | | | | |
| | 7 m | 5CL01-1AH0 | | | | |
| | 10 m | 5CL01-1BA0 | | | | |
| | 20 m | 5CL01-1CA0 | | | | |

| MOTION-CONNECT 300 cable | | | Cable connector (motor side) | | Cable connector (drive side) | |
|--------------------------------|--------|--------------------------|------------------------------------|--------------------------|------------------------------|--------------------------|
| Type | Length | Order No. 6FX3002-... | Type | Order No. 6FX2003-... | Type | Order No. 6FX2003-... |
| Power cable for FSB/FSC (c1) | 3 m | 5CL11-1AD0 | | | | |
| | 5 m | 5CL11-1AF0 | | | | |
| | 7 m | 5CL11-1AH0 | | | | |
| | 10 m | 5CL11-1BA0 | | | | |
| | 20 m | 5CL11-1CA0 | | | | |
| Incremental encoder cable (d1) | 3 m | 2CT10-1AD0 | Incremental encoder connector (d2) | 0SL11 | Encoder connector (d3) | 0SB14 |
| | 5 m | 2CT10-1AF0 | | | | |
| | 7 m | 2CT10-1AH0 | | | | |
| | 10 m | 2CT10-1BA0 | | | | |
| | 20 m | 2CT10-1CA0 | | | | |
| Absolute encoder cable (e1) | 3 m | 2DB10-1AD0 | Absolute encoder connector (e2) | 0DB11 | | |
| | 5 m | 2DB10-1AF0 | | | | |
| | 7 m | 2DB10-1AH0 | | | | |
| | 10 m | 2DB10-1BA0 | | | | |
| | 20 m | 2DB10-1CA0 | | | | |

External 24 VDC power supply

A 24 VDC power supply is needed to supply the V90 servo drive. Refer to the table below to select the power supply:

| Without a holding brake | | With a holding brake | |
|-------------------------|---------------------|---------------------------------|---------------------|
| Rated voltage (V) | Maximum current (A) | Rated voltage (V) | Maximum current (A) |
| 24 (-15% to +20%) | 1.6 | 24 (-10% to +10%) ¹⁾ | 3.6 |

¹⁾ The minimum voltage of 24 VDC -10% must be available at the connector on the motor side in order to guarantee that the brake reliably opens. If the maximum voltage of 24 VDC +10% is exceeded, then the brake could re-close. The voltage drop along the brake feeder cable must be taken into consideration. The voltage drop ΔU for copper cables can be approximately calculated as follows:

$$\Delta U [V] = 0.042 \Omega \cdot \text{mm}^2/\text{m} \cdot (l/q) \cdot I_{\text{Brake}}$$

Where: l = Cable length [m], q = Brake cable cross section [mm²], I_{Brake} = DC current of brake [A]

Fuse/circuit breaker

A fuse/circuit breaker can be used to protect the system. Refer to the table below for the selection of fuses and circuit breakers:

| SINAMICS V90 | | CE-compliant | | | | UL-compliant | | | |
|--------------|--------------------|---------------|--------------|-----------------------|----------------|-----------------------|-------|-----------------------|----------------|
| Frame size | Order number | Standard fuse | | Circuit breaker | | Standard fuse | | Circuit breaker | |
| | | Rated current | Order number | Rated current/voltage | Order number | Rated current/voltage | Class | Rated current/voltage | Order number |
| FSAA | 6SL3210-5FE10-4UA0 | 6 A | 3NA3 801-6 | 3.2 A, 690 VAC | 3RV 1021-1DA10 | 10 A, 600 VAC | J | 3.2 A, 690 VAC | 3RV 1021-1DA10 |
| FSA | 6SL3210-5FE10-8UA0 | 6 A | 3NA3 801-6 | 4 A, 690 VAC | 3RV 1021-1EA10 | 10 A, 600 VAC | J | 4 A, 690 VAC | 3RV 1021-1EA10 |
| | 6SL3210-5FE11-0UA0 | 10 A | 3NA3 803-6 | 5 A, 690 VAC | 3RV 1021-1FA10 | 10 A, 600 VAC | J | 5 A, 690 VAC | 3RV 1021-1FA10 |
| FSB | 6SL3210-5FE11-5UA0 | 10 A | 3NA3 803-6 | 10 A, 690 VAC | 3RV 1021-1HA10 | 15 A, 600 VAC | J | 10 A, 690 VAC | 3RV 1021-1HA10 |
| | 6SL3210-5FE12-0UA0 | 16 A | 3NA3 805-6 | 16 A, 690 VAC | 3RV 1021-4AA10 | 15 A, 600 VAC | J | 16 A, 690 VAC | 3RV 1021-4AA10 |
| FSC | 6SL3210-5FE13-5UA0 | 20 A | 3NA3 807-6 | 20 A, 690 VAC | 3RV 1021-4BA10 | 25 A, 600 VAC | J | 20 A, 690 VAC | 3RV 1021-4BA10 |
| | 6SL3210-5FE15-0UA0 | 20 A | 3NA3 807-6 | 20 A, 690 VAC | 3RV 1021-4BA10 | 25 A, 600 VAC | J | 20 A, 690 VAC | 3RV 1021-4BA10 |
| | 6SL3210-5FE17-0UA0 | 25 A | 3NA3 810-6 | 25 A, 690 VAC | 3RV 1021-4DA10 | 25 A, 600 VAC | J | 25 A, 690 VAC | 3RV 1021-4DA10 |

Braking resistor

The SINAMICS V90 has a built-in braking resistor, the table below shows the information of the built-in resistor:

| Frame size | Resistance (Ω) | Max. power (kW) | Rated power (W) | Max. energy (kJ) |
|------------|-------------------------|-----------------|-----------------|------------------|
| FSAA | 533 | 1.2 | 17 | 1.8 |
| FSA | 160 | 4 | 57 | 6 |
| FSB | 70 | 9.1 | 131 | 13.7 |
| FSC | 27 | 23.7 | 339 | 35.6 |

When the internal braking resistor cannot meet the braking requirements, an external braking resistor can be used to transform the regenerative electrical energy into heat, thus giving greatly improved braking and deceleration capabilities. Select a standard braking resistor according to the table below:

| Frame size | Resistance (Ω) | Max. power (kW) | Rated power (W) | Max. energy (kJ) |
|------------|-------------------------|-----------------|-----------------|------------------|
| FSA | 533 | 1.2 | 30 | 2.4 |
| FSA | 160 | 4 | 100 | 8 |
| FSB | 70 | 9.1 | 229 | 18.3 |
| FSC | 27 | 23.7 | 1185 | 189.6 |

Filter

Siemens recommends you to use a line filter to protect the system from high frequency noise. The table below lists all filters recommended by Siemens:

| Frame size | Rated current (A) | Degree of protection | Order number |
|------------|-------------------|----------------------|--------------------|
| FSA | 5 | IP20 | 6SL3203-0BE15-0VA0 |
| FSA | 5 | IP20 | 6SL3203-0BE15-0VA0 |
| FSB | 12 | IP20 | 6SL3203-0BE21-2VA0 |
| FSC | 20 | IP20 | 6SL3203-0BE22-0VA0 |

Installation

Connecting the line filter to the drive

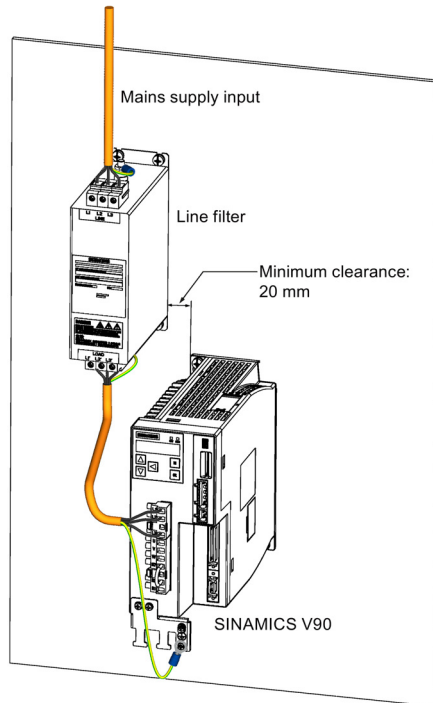

SD card

Optionally an SD card can be used to copy drive parameters or perform a firmware update. You are recommended to use the SIEMENS SD card (order number: **6ES7954-8LB01-0AA0**).

You can also select other high quality SD cards with a maximum capacity of 2 GB from manufacturers such as KINGMAX, Kingston or SanDisk.

Replacement fans (for frame sizes B and C only)

Order numbers:

Fan kits for frame size B: 6SL3200-0WF00-0AA0

Fan kits for frame size C: 6SL3200-0WF01-0AA0

2.6 Function list

| Function | Description | Control mode |
|---|---|-----------------------------------|
| Pulse train input position control (PTI) (Page 135) | Implements accurate positioning through two pulse train input channels: 5 V differential or 24 V single end signal. In addition, it supports S-curve position smoothing function | PTI |
| Internal position control (IPos) (Page 148) | Implements accurate positioning through internal position commands (up to eight groups) and allows to specify the acceleration/speed for positioning | IPos |
| Speed control (S) (Page 164) | Flexibly controls motor speed and direction through external analog speed commands (0 - ± 10 VDC) or internal speed commands (up to seven groups) | S |
| Torque control (T) (Page 170) | Flexibly controls motor output torque through external analog torque commands (0 - ± 10 VDC) or internal torque commands. In addition, it supports speed limit function to prevent overspeed when a motor has no loads | T |
| Compound controls (Page 127) | Supports flexible switches among position control mode, speed control mode, and torque control mode | PTI/S, IPos/S, PTI/T, IPos/T, S/T |
| Absolute position system (Page 173) | Allows to implement motion control tasks immediately after the servo system with an absolute encoder is powered on, needless of carrying out referencing or zero position operation beforehand | PTI |
| Gain switching (Page 207) | Switches between gains during motor rotation or stop with an external signal or internal parameters to reduce noise and positioning time, or improve the operation stability of a servo system | PTI, IPos, S |
| PI/P switching (Page 211) | Switches from PI control to P control with an external signal or internal parameters to suppress overshooting during acceleration or deceleration (for speed control mode) or to suppress undershooting during positioning and reduce the settling time (for position control mode) | PTI, IPos, S |
| Safe Torque Off (STO) (Page 193) | Safely disconnects torque-generating motor power supply to prevent an unintentional motor restart | PTI, IPos, S, T |

2.6 Function list

| Function | Description | Control mode |
|---|--|-----------------|
| Zero speed clamp (Page 167) | Stops motor and clamps the motor shaft when motor speed setpoint is below a parameterized threshold level | S |
| Real-time auto tuning (Page 201) | Estimates the machine characteristic and sets the closed loop control parameters (position loop gain, speed loop gain, speed integral compensation, filter if necessary, etc.) continuously in real time without any user intervention | PTI, IPos, S |
| Resonance suppression (Page 204) | Suppresses the mechanical resonance, such as workpiece vibration and base shake | PTI, IPos, S, T |
| Speed limit (Page 142) | Limits motor speed through external analog speed limit commands (0 - ±10 VDC) or internal speed limit commands (up to three groups) | PTI, IPos, S, T |
| Torque limit (Page 143) | Limits motor torque through external analog torque limit commands (0 - ±10 VDC) or internal torque limit commands (up to three groups) | PTI, IPos, S |
| Electronic gear ratio (Page 137) | Defines a multiplier factor for input pulses | PTI, IPos |
| Basic operator panel (BOP) (Page 109) | Displays servo status on a 6-digit 7-segment LED display | PTI, IPos, S, T |
| External braking resistor - DCP, R1 (Page 97) | An external braking resistor can be used when the internal braking resistor is insufficient for regenerative energy | PTI, IPos, S, T |
| Digital inputs/outputs (DIs/DOs) (Page 60) | Control signals and status signals can be assigned to eight programmable digital inputs and six digital outputs | PTI, IPos, S, T |
| Smoothing function (Page 136) | Transforms position characteristics from the pulse train input setpoint into an S-curve profile with a parameterized time constant | PTI |
| SINAMICS V-ASSISTANT | You can perform parameter settings, test operation, adjustment and other operations with a PC | PTI, IPos, S, T |

2.7 Technical data

2.7.1 Technical data - servo drives

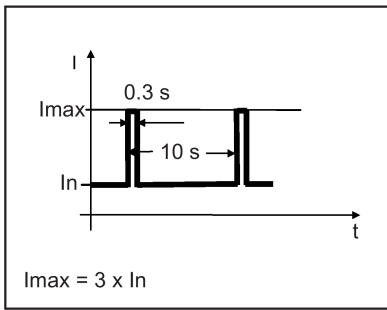
| Order No. | 6SL3210-5FE... | 10-4UA0 | 10-8UA0 | 11-0UA0 | 11-5UA0 | 12-0UA0 | 13-5UA0 | 15-0UA0 | 17-0UA0 |
|---------------------------------|-----------------------------------|---|------------|------------|------------|------------|------------|------------|------------|
| Frame size | | FSAA | FSA | FSA | FSB | FSB | FSC | FSC | FSC |
| Rated output current (A) | | 1.2 | 2.1 | 3.0 | 5.3 | 7.8 | 11.0 | 12.6 | 13.2 |
| Max. output current (A) | | 3.6 | 6.3 | 9.0 | 13.8 | 23.4 | 33.0 | 37.8 | 39.6 |
| Max. supported motor power (kW) | | 0.4 | 0.75 | 1.0 | 1.75 | 2.5 | 3.5 | 5.0 | 7.0 |
| Output frequency (Hz) | | 0 to 330 | | | | | | | |
| Power supply | Voltage/frequency | 3-phase 380 VAC to 480 VAC, 50/60 Hz | | | | | | | |
| | Permissible voltage fluctuation | -15% to +10% | | | | | | | |
| | Permissible frequency fluctuation | -10% to +10% | | | | | | | |
| | Rated input current (A) | 1.5 | 2.6 | 3.8 | 5.8 | 9.8 | 13.8 | 15.8 | 16.5 |
| | Power supply capacity (kVA) | 1.7 | 3.0 | 4.3 | 6.6 | 11.1 | 15.7 | 18.0 | 18.9 |
| | Inrush current (A) | 8.0 | 8.0 | 8.0 | 4.0 | 4.0 | 2.5 | 2.5 | 2.5 |
| 24 VDC power supply | Voltage (V) | 24 (-15% to +20%) ¹⁾ | | | | | | | |
| | Maximum current (A) | 1.6 A (when using a motor without a brake) 3.6 A (when using a motor with a brake) | | | | | | | |
| Overload capability | | 300% | | | | | | | |
| | |  <p style="text-align: center;">$I_{max} = 3 \times I_n$</p> | | | | | | | |
| Control system | | Servo control | | | | | | | |
| Braking resistor | | Built-in | | | | | | | |
| Protective functions | | Earthing fault protection, output short-circuit protection ²⁾ , overvoltage/undervoltage protection, I ² t detection, IGBT overtemperature protection ³⁾ | | | | | | | |
| Speed control mode | Speed control range | Analog speed command 1:2000, internal speed command 1:5000 | | | | | | | |
| | Analog speed command input | -10 VDC to +10 VDC/rated speed | | | | | | | |
| | Torque limit | Set through a parameter or the analog input command (0 V - +10 VDC/max. torque) | | | | | | | |

General information

2.7 Technical data

| Order No. | 6SL3210-5FE... | | | 10-4UA0 | 10-8UA0 | 11-0UA0 | 11-5UA0 | 12-0UA0 | 13-5UA0 | 15-0UA0 | 17-0UA0 | | | | | | | | | | | | | | | | | | | | | | | | | |
|---|----------------------------------|--|--|----------------|----------------|----------------|----------------|----------------|----------------|----------------|----------------|------------------|------------------|------------------|------|-----|------|-----|------|-----|------|-----|------|-----|----|-----|----|-----|----|-----|----|-----|----|----|----|----|
| Frame size | | | | FSA | FSA | FSA | FSB | FSB | FSC | FSC | FSC | | | | | | | | | | | | | | | | | | | | | | | | | |
| Position control mode | Max. input pulse frequency | 1 M (differential input), 200 kpps (open collector input) | | | | | | | | | | | | | | | | | | | | | | | | | | | | | | | | | | |
| | Command pulse multiplying factor | Electronic gear ratio (A/B) A: 1 - 10000, B: 1 - 10000 $1/50 < A/B < 200$ | | | | | | | | | | | | | | | | | | | | | | | | | | | | | | | | | | |
| | In-position range setting | 0 to ± 10000 pulse (command pulse unit) | | | | | | | | | | | | | | | | | | | | | | | | | | | | | | | | | | |
| | Error excessive | ± 10 revolutions | | | | | | | | | | | | | | | | | | | | | | | | | | | | | | | | | | |
| | Torque limit | Set through a parameter or the analog input command (0 V - +10 VDC/max. torque) | | | | | | | | | | | | | | | | | | | | | | | | | | | | | | | | | | |
| Torque control mode | Analog torque command input | -10 V to +10 VDC/max. torque (input impedance 10 k Ω - 12 k Ω) | | | | | | | | | | | | | | | | | | | | | | | | | | | | | | | | | | |
| | Speed limit | Set through a parameter or the analog input command (0 V - +10 VDC/max. rated speed) | | | | | | | | | | | | | | | | | | | | | | | | | | | | | | | | | | |
| Cooling method | | Self-cooled | | | Fan-cooled | | | | | | | | | | | | | | | | | | | | | | | | | | | | | | | |
| Environmental conditions | Surrounding air temperature | Operation | 0 °C to 45 °C: without power derating 45 °C to 55 °C: with power derating | | | | | | | | | | | | | | | | | | | | | | | | | | | | | | | | | |
| | | <table border="1"> <caption>Output power (%) vs Temperature (°C)</caption> <thead> <tr> <th>Temperature (°C)</th> <th>Output power (%)</th> </tr> </thead> <tbody> <tr><td>5</td><td>100</td></tr> <tr><td>10</td><td>100</td></tr> <tr><td>15</td><td>100</td></tr> <tr><td>20</td><td>100</td></tr> <tr><td>25</td><td>100</td></tr> <tr><td>30</td><td>100</td></tr> <tr><td>35</td><td>100</td></tr> <tr><td>40</td><td>100</td></tr> <tr><td>45</td><td>100</td></tr> <tr><td>50</td><td>90</td></tr> <tr><td>55</td><td>80</td></tr> </tbody> </table> | | | | | | | | | | | Temperature (°C) | Output power (%) | 5 | 100 | 10 | 100 | 15 | 100 | 20 | 100 | 25 | 100 | 30 | 100 | 35 | 100 | 40 | 100 | 45 | 100 | 50 | 90 | 55 | 80 |
| | | Temperature (°C) | Output power (%) | | | | | | | | | | | | | | | | | | | | | | | | | | | | | | | | | |
| | 5 | 100 | | | | | | | | | | | | | | | | | | | | | | | | | | | | | | | | | | |
| | 10 | 100 | | | | | | | | | | | | | | | | | | | | | | | | | | | | | | | | | | |
| | 15 | 100 | | | | | | | | | | | | | | | | | | | | | | | | | | | | | | | | | | |
| | 20 | 100 | | | | | | | | | | | | | | | | | | | | | | | | | | | | | | | | | | |
| | 25 | 100 | | | | | | | | | | | | | | | | | | | | | | | | | | | | | | | | | | |
| | 30 | 100 | | | | | | | | | | | | | | | | | | | | | | | | | | | | | | | | | | |
| | 35 | 100 | | | | | | | | | | | | | | | | | | | | | | | | | | | | | | | | | | |
| 40 | 100 | | | | | | | | | | | | | | | | | | | | | | | | | | | | | | | | | | | |
| 45 | 100 | | | | | | | | | | | | | | | | | | | | | | | | | | | | | | | | | | | |
| 50 | 90 | | | | | | | | | | | | | | | | | | | | | | | | | | | | | | | | | | | |
| 55 | 80 | | | | | | | | | | | | | | | | | | | | | | | | | | | | | | | | | | | |
| Storage | -40 °C to +70 °C | | | | | | | | | | | | | | | | | | | | | | | | | | | | | | | | | | | |
| Surrounding humidity | Operation | < 90% (non-condensing) | | | | | | | | | | | | | | | | | | | | | | | | | | | | | | | | | | |
| | Storage | 90% (non-condensing) | | | | | | | | | | | | | | | | | | | | | | | | | | | | | | | | | | |
| Operating environment | | Indoors (without direct sunlight), free from corrosive gas, combustible gas, oil gas, or dust | | | | | | | | | | | | | | | | | | | | | | | | | | | | | | | | | | |
| Altitude | | ≤ 1000 m (without power derating) | | | | | | | | | | | | | | | | | | | | | | | | | | | | | | | | | | |
| <table border="1"> <caption>Output power (%) vs Altitude (m)</caption> <thead> <tr> <th>Altitude (m)</th> <th>Output power (%)</th> </tr> </thead> <tbody> <tr><td>0</td><td>100</td></tr> <tr><td>1000</td><td>100</td></tr> <tr><td>2000</td><td>85</td></tr> <tr><td>3000</td><td>75</td></tr> <tr><td>4000</td><td>68</td></tr> <tr><td>5000</td><td>65</td></tr> </tbody> </table> | | | | | | | | | | | Altitude (m) | Output power (%) | 0 | 100 | 1000 | 100 | 2000 | 85 | 3000 | 75 | 4000 | 68 | 5000 | 65 | | | | | | | | | | | | |
| Altitude (m) | Output power (%) | | | | | | | | | | | | | | | | | | | | | | | | | | | | | | | | | | | |
| 0 | 100 | | | | | | | | | | | | | | | | | | | | | | | | | | | | | | | | | | | |
| 1000 | 100 | | | | | | | | | | | | | | | | | | | | | | | | | | | | | | | | | | | |
| 2000 | 85 | | | | | | | | | | | | | | | | | | | | | | | | | | | | | | | | | | | |
| 3000 | 75 | | | | | | | | | | | | | | | | | | | | | | | | | | | | | | | | | | | |
| 4000 | 68 | | | | | | | | | | | | | | | | | | | | | | | | | | | | | | | | | | | |
| 5000 | 65 | | | | | | | | | | | | | | | | | | | | | | | | | | | | | | | | | | | |
| Degree of protection | | IP20 | | | | | | | | | | | | | | | | | | | | | | | | | | | | | | | | | | |
| Degree of pollution | | Class 2 | | | | | | | | | | | | | | | | | | | | | | | | | | | | | | | | | | |

| | | | | | | | | | | |
|-------------------|---|----------------|---|---|-----------------|---------|-----------------|---------|---------|---------|
| Order No. | 6SL3210-5FE... | | 10-4UA0 | 10-8UA0 | 11-0UA0 | 11-5UA0 | 12-0UA0 | 13-5UA0 | 15-0UA0 | 17-0UA0 |
| Frame size | | | FSA A | FSA | FSA | FSB | FSB | FSC | FSC | FSC |
| | Vibration | Operation | Shock: | Operational area II Peak acceleration: 5 g Duration of shock: 30 ms | | | | | | |
| | | | Vibration: | Operational area II 10 Hz to 58 Hz: 0.075 mm deflection 58 Hz to 200 Hz: 1g vibration | | | | | | |
| | Transport & storage | Vibration: | 5 Hz to 9 Hz: 7.5 mm deflection 9 Hz to 200 Hz: 2 g vibration Vibration class: 2M3 transportation | | | | | | | |
| Certifications |  | | | | | | | | | |
| Mechanical design | Outline dimensions (W x H x D, mm) | 60 x 180 x 200 | 80 x 180 x 200 | | 100 x 180 x 220 | | 140 x 260 x 240 | | | |
| Weight (kg) | | | 1.800 | 2.500 | 2.510 | 3.055 | 3.130 | 6.515 | 6.615 | 6.615 |



- 1) When SINAMICS V90 works with a motor with a brake, the voltage tolerance of 24 VDC power supply must be -10% to +10% to meet the voltage requirement of the brake.
- 2) Integral solid state short circuit protection does not provide branch circuit protection. Branch circuit protection must be provided in accordance with the National Electrical Code and any additional local codes.
- 3) SINAMICS V90 does not support motor overtemperature protection. Motor overtemperature is calculated by I^2t and protected by the output current from the drive.

2.7.2 Technical data - servo motors

General technical data

| Parameter | Description |
|--------------------------------------|--|
| Type of motor | Permanent-magnet synchronous motor |
| Cooling | Self-cooled |
| Operating temperature [°C] | 0 to 40 (without power derating) |
| Storage temperature [°C] | -15 to +65 |
| Relative humidity [RH] | 90% (non-condensing at 30°C) |
| Installation altitude [m] | ≤ 1000 (without power derating) |
| Maximum noise level [dB] | 1FL604□: 65 1FL606□: 70 1FL609□: 70 |
| Thermal class | B |
| Vibration severity grade | A (according to IEC 60034-14) |
| Shock resistance [m/s ²] | 25 (continuous in axial direction); 50 (continuous in radial direction); 250 (in a short time of 6 ms) |

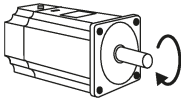
2.7 Technical data

| Parameter | | Description | | |
|-----------------------|-----------------------------------|---|----------------|---------------|
| Holding brake | Rated voltage (V) | 24 ± 10% | | |
| | Rated current (A) | 1FL604□: 0.88 | 1FL606□ : 1.44 | 1FL609□: 1.88 |
| | Holding brake torque [Nm] | 1FL604□: 3.5 | 1FL606□ : 12 | 1FL609□: 30 |
| | Maximum brake opening time [ms] | 1FL604□: 60 | 1FL606□ : 180 | 1FL609□: 220 |
| | Maximum brake closing time [ms] | 1FL604□: 45 | 1FL606□ : 60 | 1FL609□: 115 |
| | Maximum number of emergency stops | 2000 ¹⁾ | | |
| Bearing lifetime [h] | | > 20000 ²⁾ | | |
| Oil seal lifetime [h] | | 5000 | | |
| Encoder lifetime [h] | | 20000 - 30000 ³⁾ | | |
| Paint finish | | Black | | |
| Degree of protection | | IP65, with shaft oil seal | | |
| Type of construction | | IM B5, IM V1 and IM V3 | | |
| Positive rotation | |  <p>Clockwise (default setting in SINAMICS V90 servo drives)</p> | | |
| Certification | |  | | |

- 1) Restricted emergency stop operation is permissible. Up to 2000 braking operations can be executed with 300% rotor moment of inertia as external moment of inertia from a speed of 3000 RPM without the brake being subject to an inadmissible amount of wear.
- 2) This lifetime is only for reference. When a motor keeps running at rated speed under rated load, replace its bearing after 20,000 to 30,000 hours of service time. Even if the time is not reached, the bearing must be replaced when unusual noise, vibration, or faults are found.
- 3) This lifetime is only for reference. When a motor keeps running at 80% rated value and the surrounding temperature is 30 °C, the encoder lifetime can be ensured.

Specific technical data

| Order No. | 1FL60... | 42 | 44 | 61 | 62 | 64 | 66 | 67 | 90 | 92 | 94 | 96 |
|---|---------------|---------|------|--------|------|------|------|--------|------|------|------|-------------------|
| Rated power [kW] | | 0.40 | 0.75 | 0.75 | 1.00 | 1.50 | 1.75 | 2.00 | 2.5 | 3.5 | 5.0 | 7.0 ¹⁾ |
| Rated torque [Nm] | | 1.27 | 2.39 | 3.58 | 4.78 | 7.16 | 8.36 | 9.55 | 11.9 | 16.7 | 23.9 | 33.4 |
| Maximum torque [Nm] | | 3.8 | 7.2 | 10.7 | 14.3 | 21.5 | 25.1 | 28.7 | 35.7 | 50.0 | 70.0 | 90.0 |
| Rated speed [rpm] | | 3000 | | 2000 | | | | 2000 | | | | |
| Maximum speed [rpm] | | 4000 | | 3000 | | | | 3000 | | 2500 | 2000 | |
| Rated frequency [Hz] | | 200 | | 133 | | | | 133 | | | | |
| Rated current [A] | | 1.2 | 2.1 | 2.5 | 3.0 | 4.6 | 5.3 | 5.9 | 7.8 | 11.0 | 12.6 | 13.2 |
| Maximum current [A] | | 3.6 | 6.3 | 7.5 | 9.0 | 13.8 | 15.9 | 17.7 | 23.4 | 33.0 | 36.9 | 35.6 |
| Moment of inertia [10 ⁻⁴ kgm ²] | | 2.7 | 5.2 | 8.0 | 15.3 | 15.3 | 22.6 | 29.9 | 47.4 | 69.1 | 90.8 | 134.3 |
| Moment of inertia (with brake) [10 ⁻⁴ kgm ²] | | 3.2 | 5.7 | 9.1 | 16.4 | 16.4 | 23.7 | 31.0 | 56.3 | 77.9 | 99.7 | 143.2 |
| Recommended load to motor inertia ration | | < 1000% | | < 500% | | | | < 500% | | | | |
| Weight of incremental encoder motor [kg] | With brake | 4.6 | 6.4 | 8.6 | 11.3 | 11.3 | 14.0 | 16.6 | 21.3 | 25.7 | 30.3 | 39.1 |
| | Without brake | 3.3 | 5.1 | 5.6 | 8.3 | 8.3 | 11.0 | 13.6 | 15.3 | 19.7 | 24.3 | 33.2 |
| Weight of absolute encoder motor [kg] | With brake | 4.4 | 6.2 | 8.3 | 11.0 | 11.0 | 13.6 | 16.3 | 20.9 | 25.3 | 29.9 | 38.7 |
| | Without brake | 3.1 | 4.9 | 5.3 | 8.0 | 8.0 | 10.7 | 13.3 | 14.8 | 19.3 | 23.9 | 32.7 |

¹⁾ When the surrounding temperature is higher than 30 °C, the 1FL6096 motors with brake will have a power derating of 10%.

Note

The data of rated torque, rated power, maximum torque, and armature resistance in the above table allow a tolerance of 10%.

Torque-Speed characteristics

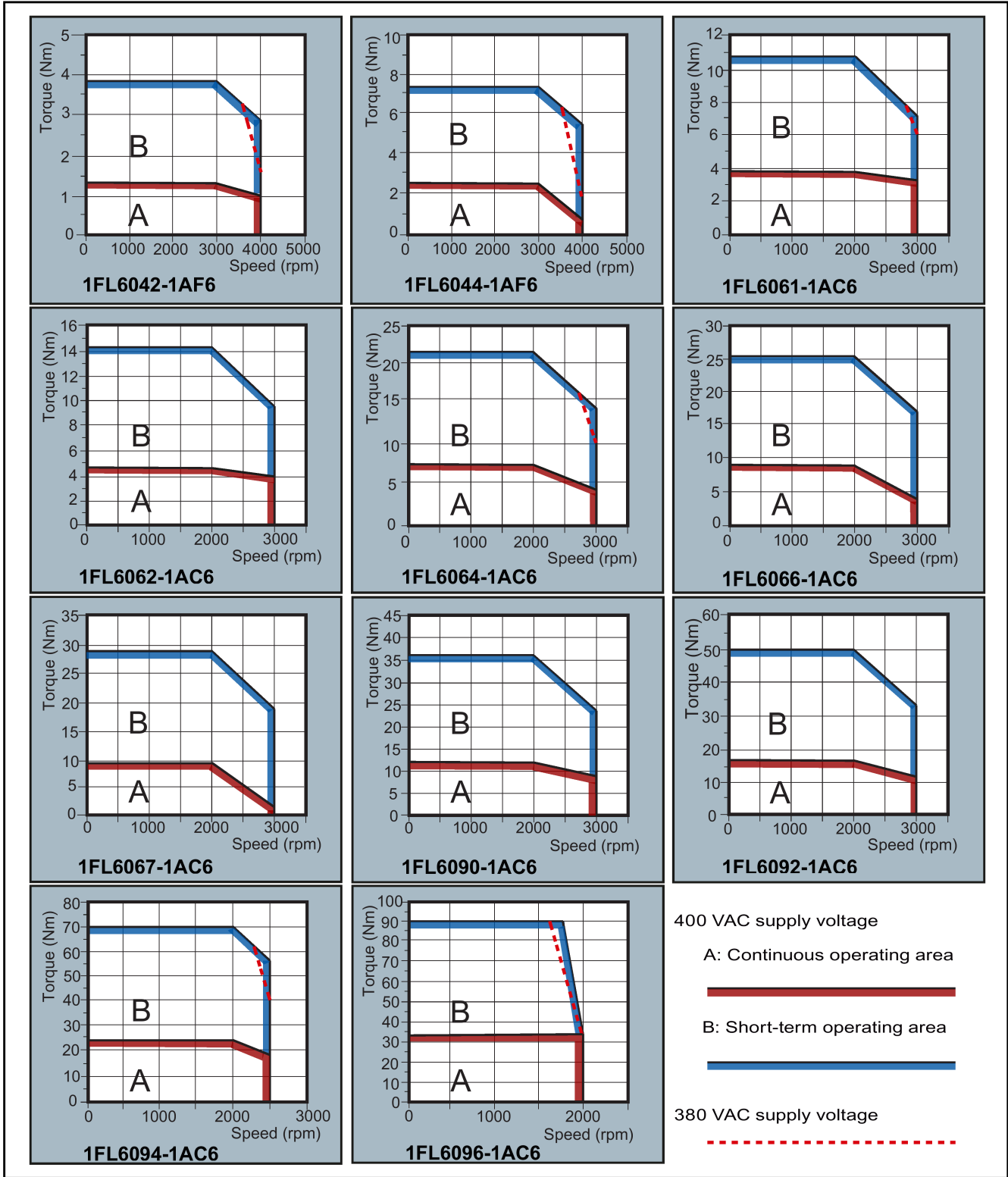

Note

- Continuous operating area is a series of states when a motor can operate continuously and safely. The effective torque must be located in this area.
- Short-term operating area is a series of states when a motor can operate for a short duration if its effective torque is smaller than the rated torque.
- For the motors with different rated and maximum speeds, the output torque will decline at a faster rate after the speed exceeds the rated speed.
- The feature in short-term operating area varies with power supply voltages.
- The continuous operating area becomes smaller and the voltage drop grows larger when the cables in the major loop exceed 20 meters.
- For 1FL6096 motors, the maximum speed can be ensured when the line supply voltage is higher than 380V.

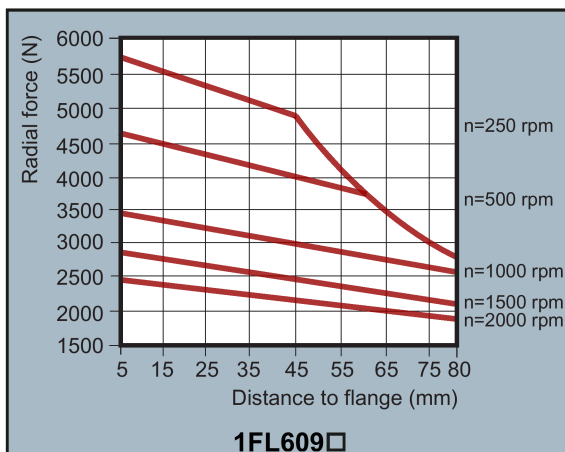
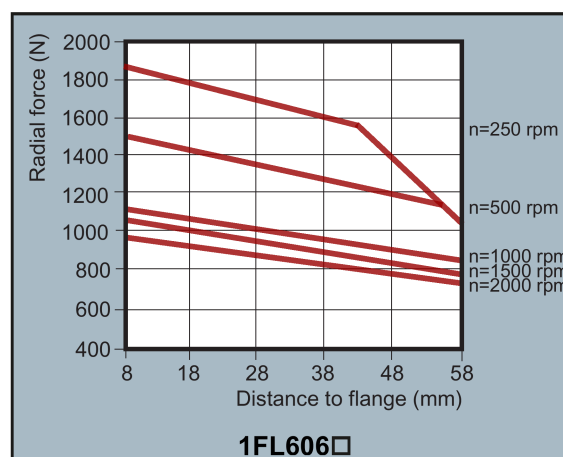
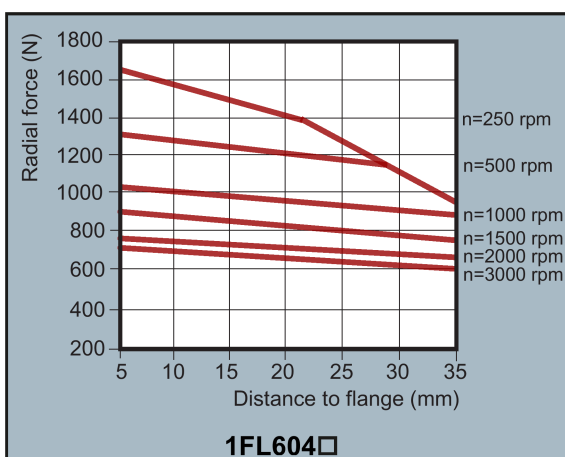
Permissible radial and axial forces**Axial force:**

When using, for example, helical toothed wheels as drive element, in addition to the radial force, there is also an axial force on the motor bearings. For axial forces, the spring-loading of the bearings can be overcome so that the rotor moves corresponding to the axial bearing present (up to 0.2 mm).

The permissible axial force can be approximately calculated using the following formula:

$$F_A = 0.35 \cdot F_Q$$

Where F_A represents axial force and F_Q radial force.

Note

1FL604□ and 1FL609□ have a 5 mm of shaft sheltered in sleeves, and 1FL606□ has an 8 mm of shaft in sleeves. Therefore, the distances to flange in the above three figures begin respectively from 5 mm, 8mm, and 5 mm.

2.7.3 Technical data - cables

| Parameter | MOTION-CONNECT 300 Power Cable | MOTION-CONNECT 300 Encoder Cable | MOTION-CONNECT 300 Brake Cable |
|---|---|----------------------------------|--------------------------------|
| Material | PVC | PVC | PVC |
| Degree of protection (motor-side only) | IP65 | IP65 | IP65 |
| Number of cores | 4 | 10 | 2 |
| Cross-section of cores (mm ²) | 4 x 1.5 (for FSAA/FSA) 4 x 2.5 (for FSB/FSC) | 6 x 0.22 + 4 x 0.25 | 2 x 0.75 |
| Rated voltage (V) | 600/1000 | 30 | 30 |
| Operation temperature (°C) | -25 to 80 | | |
| Shielding | Yes | | |
| Minimum bending radius, static (mm) | 6 x outer diameter | | |
| Bending cycles | 1000000 | | |
| Oil resistance | EN60811-2-1 fulfilled | | |
| Flame-retardant | EN60332-1-1to 1-3 fulfilled | | |
| Certifications | RoHS, UL, CE | | |

Mounting

3.1 Mounting the drive

For mounting conditions, see Technical data - servo drives (Page 37).

3.1.1 Mounting orientation and clearance

Mount the drive vertically in a shielded cabinet and observe the mounting clearances specified in the illustration below:

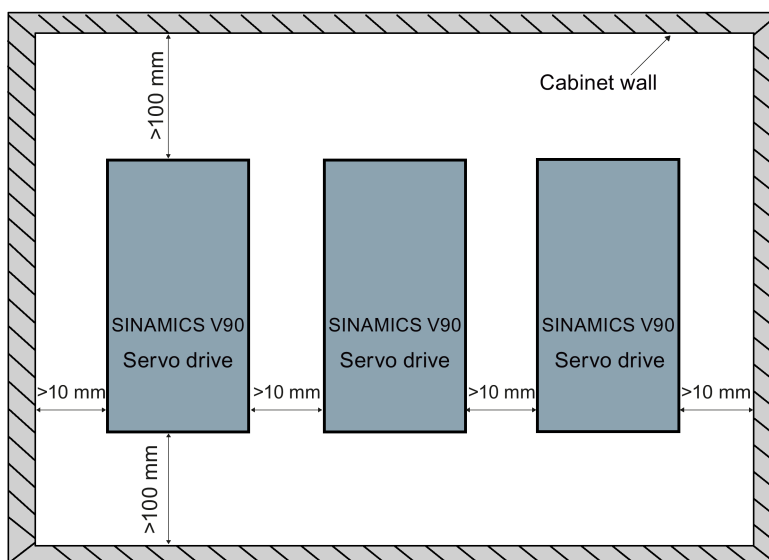

Note

The drive should be derated to 80% when the following conditions are satisfied:

- The surrounding temperature is 0 °C to 45 °C , and the mounting clearance is less than 10 mm . In this case, the minimum mounting clearance should not be less than 5 mm .
- The surrounding temperature is 45 °C to 55 °C . In this case, the minimum mounting clearance should not be less than 20 mm .

3.1.2 Drill patterns and outline dimensions

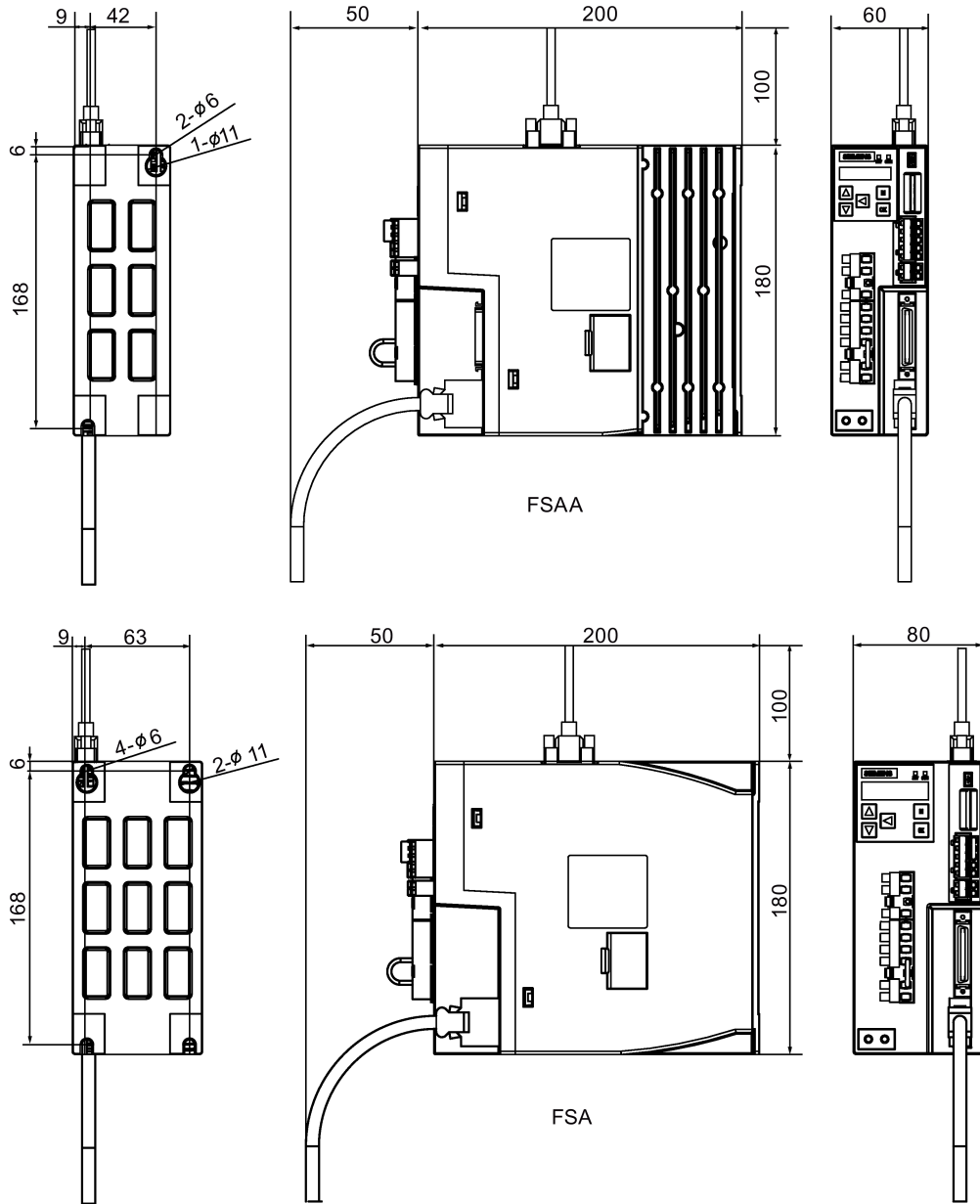

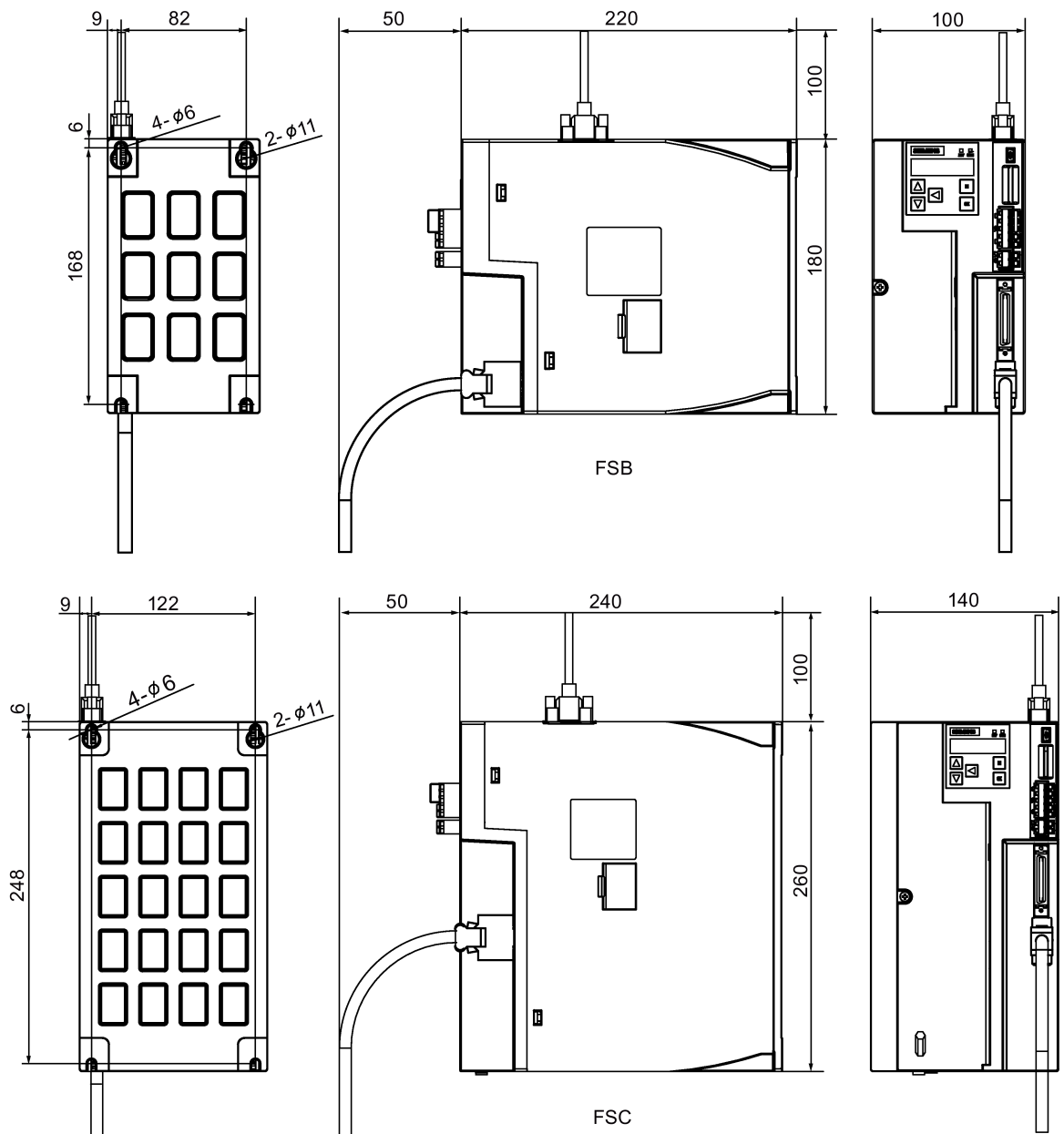

3.1.3 Mounting the drive

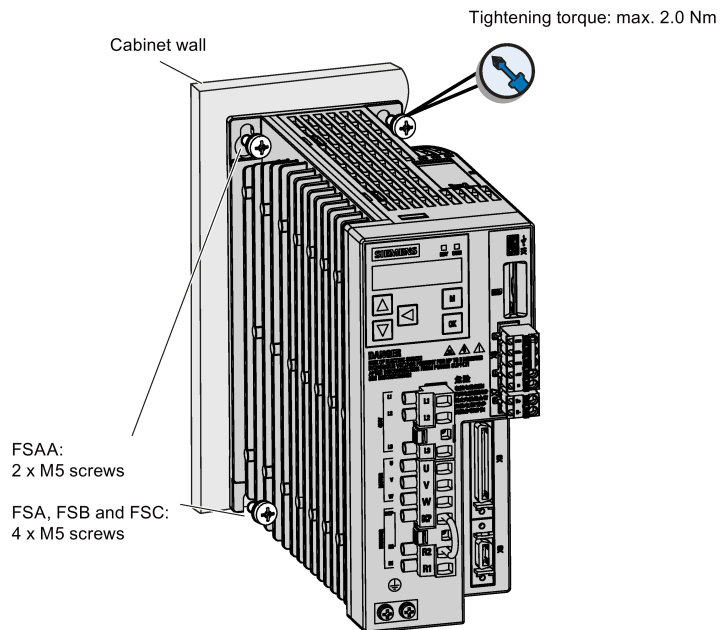

Note

Taking EMC factors into account, you are recommended to mount the drive in a shielded cabinet.

3.2 Mounting the motor

For mounting conditions, see Technical data - servo motors (Page 39).

3.2.1 Mounting orientation and dimensions

Mounting orientation

SIMOTICS S-1FL6 supports flange mounting only and three types of constructions, so it can be installed in three orientations as shown in the following figure.

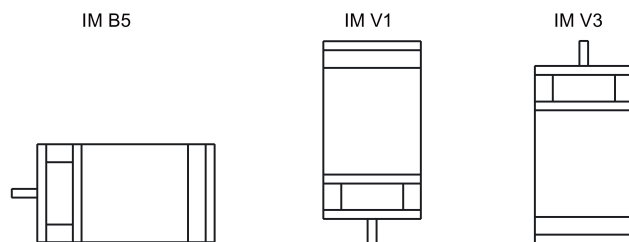

Note

When configuring the IM V3 type of construction, pay particular attention to the permissible axial force (weight force of the drive elements) and the necessary degree of protection.

Motor dimensions

Shaft-height 45 mm, with incremental encoder (unit: mm)

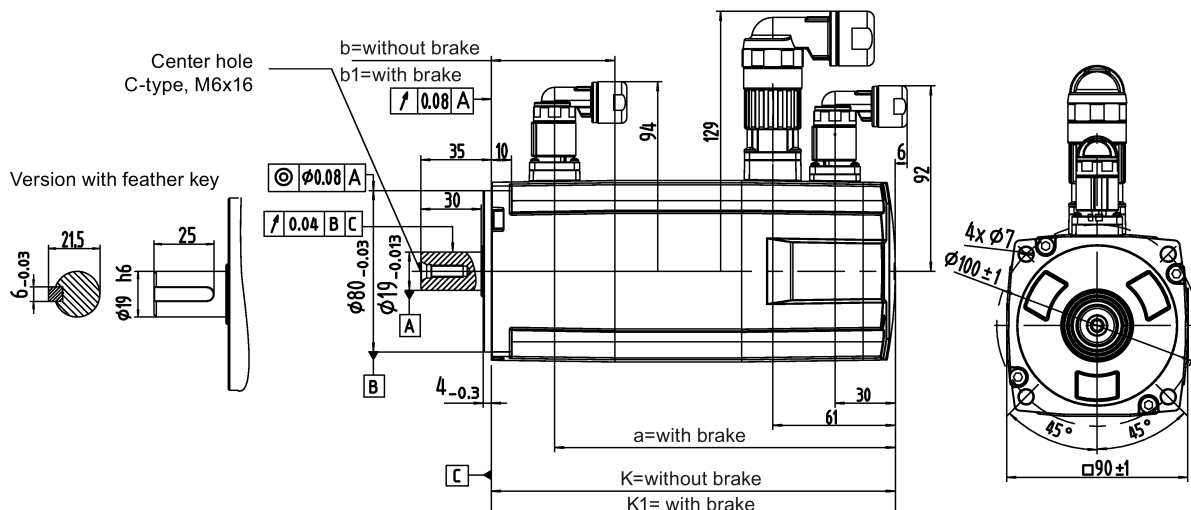

| Rated power | Rated torque | k | k1 | a | b | b1 |
|-------------|--------------|-------|-----|-------|----|------|
| 0.4 kW | 1.27 Nm | 154.5 | 201 | 169.5 | 15 | 61.5 |
| 0.75 kW | 2.39 Nm | 201.5 | 248 | 216.5 | | |

Shaft-height 45 mm, with absolute encoder (unit: mm)

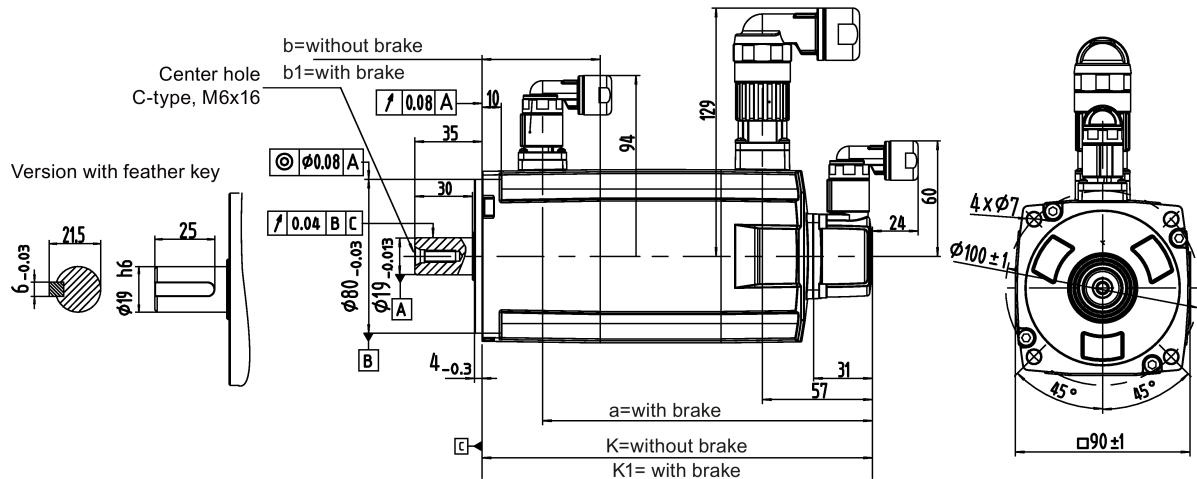

| Rated power | Rated torque | k | k1 | a | b | b1 |
|-------------|--------------|-----|-------|-----|----|------|
| 0.4 kW | 1.27 Nm | 157 | 203.5 | 172 | 15 | 61.5 |
| 0.75 kW | 2.39 Nm | 204 | 250.5 | 219 | | |

Shaft-height 65 mm, with incremental encoder (unit: mm)

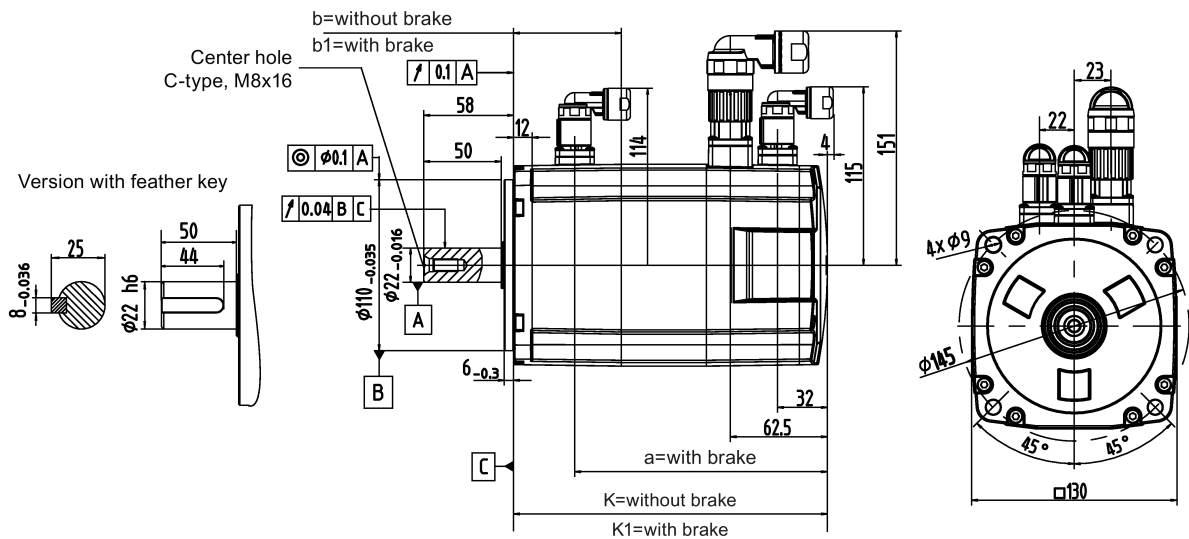

| Rated power | Rated torque | k | k1 | a | b | b1 |
|-------------|--------------|-----|-------|-----|----|------|
| 0.75 kW | 3.58 Nm | 148 | 202.5 | 163 | 15 | 69.5 |
| 1.0 kW | 4.78 Nm | 181 | 235.5 | 196 | | |
| 1.5 kW | 7.16 Nm | 181 | 235.5 | 196 | | |
| 1.75 kW | 8.36 Nm | 214 | 268.5 | 229 | | |
| 2.0 kW | 9.55 Nm | 247 | 301.5 | 262 | | |

Shaft-height 65 mm, with absolute encoder (unit: mm)

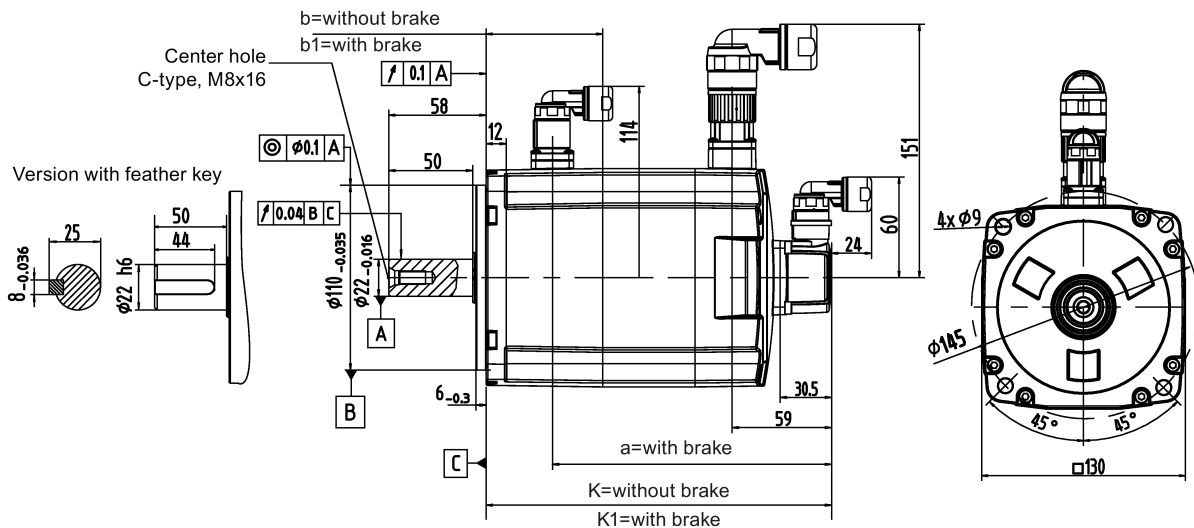

| Rated power | Rated torque | k | k1 | a | b | b1 |
|-------------|--------------|-----|-------|-----|----|------|
| 0.75 kW | 3.58 Nm | 151 | 205.5 | 166 | 15 | 69.5 |
| 1.0 kW | 4.78 Nm | 184 | 238.5 | 199 | | |
| 1.5 kW | 7.16 Nm | 184 | 238.5 | 199 | | |
| 1.75 kW | 8.36 Nm | 217 | 271.5 | 232 | | |
| 2.0 kW | 9.55 Nm | 250 | 304.5 | 265 | | |

Shaft-height 90 mm, with incremental encoder (unit: mm)

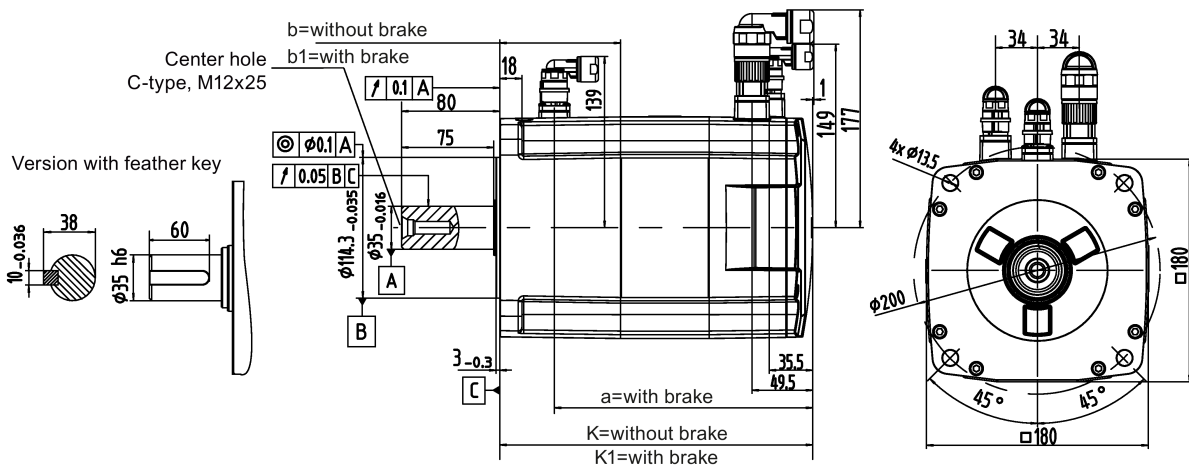

| Rated power | Rated torque | k | k1 | a | b | b1 |
|-------------|--------------|-------|-----|-------|----|------|
| 2.5 kW | 11.9 Nm | 189.5 | 255 | 210.5 | 33 | 98.5 |
| 3.5 kW | 16.7 Nm | 211.5 | 281 | 236.5 | | |
| 5.0 kW | 23.9 Nm | 237.5 | 307 | 262.5 | | |
| 7.0 kW | 33.4 Nm | 289.5 | 359 | 314.5 | | |

3.2 Mounting the motor

Shaft-height 90 mm, with absolute encoder (unit: mm)

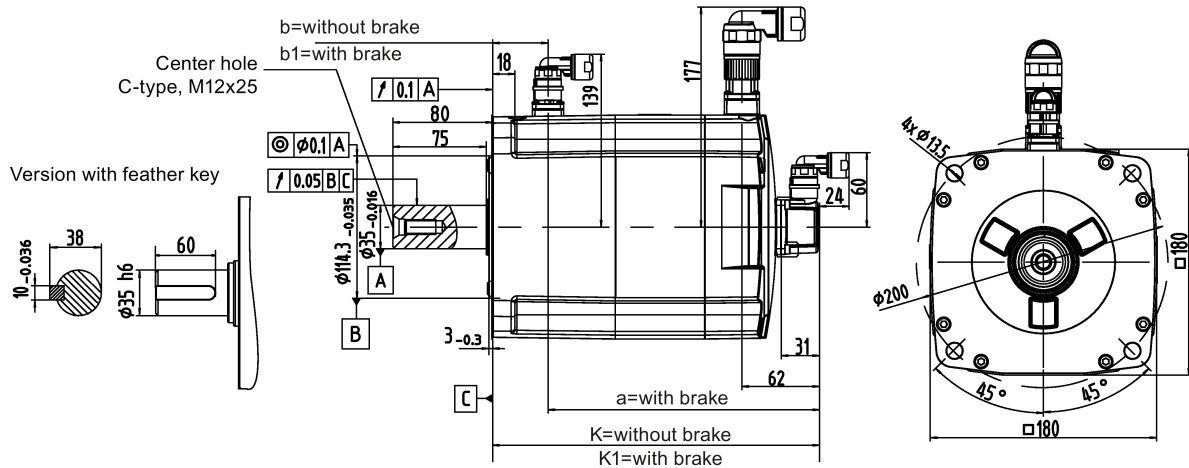

| Rated power | Rated torque | k | k1 | a | b | b1 |
|-------------|--------------|-----|-----|-----|----|------|
| 2.5 kW | 11.9 Nm | 197 | 263 | 218 | 33 | 98.5 |
| 3.5 kW | 16.7 Nm | 223 | 289 | 244 | | |
| 5.0 kW | 23.9 Nm | 249 | 315 | 270 | | |
| 7.0 kW | 33.4 Nm | 301 | 367 | 322 | | |

3.2.2 Mounting the motor

WARNING

Personal injury and material damage

Some motors, especially the 1FL609□ are heavy. The excessive weight of the motor should be considered and any necessary assistance required for mounting should be sought.

Otherwise, the motor can fall down during mounting. This can result in serious personal injury or material damage.

NOTICE

Damage to the motor

If the liquid enters the motor, the motor may be damaged

During motor installation or operation, make sure that no liquid (water, oil, etc.) can penetrate into the motor. Besides, when installing the motor horizontally, make sure that the cable outlet faces downward to protect the motor from ingress of oil or water.

Note

Using the eyebolts

The 1FL609□ motor (90 mm shaft height) has two M8 screw holes for screwing in two eyebolts. Lift the 1FL609□ motor only at the eyebolts.

Eyebolts that have been screwed in must be either tightened or removed after mounting.

To ensure better heat dissipation, install a flange between the machine and the motor. You can install the motor onto the flange with 4 screws as shown in the following figure.

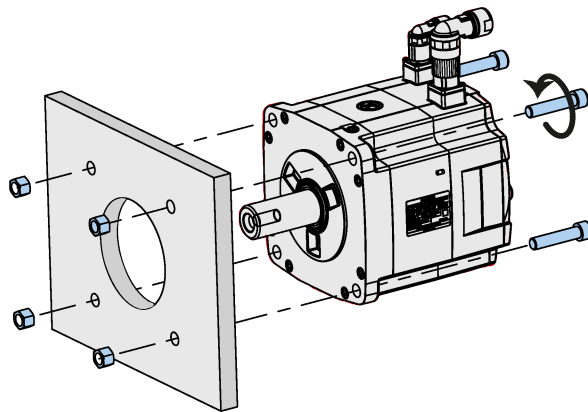

The information about the screws and the flange is as follows:

| Motor | Screw | Recommended flange size | Tightening torque | Flange material |
|---------|---------|-------------------------|-------------------|-----------------|
| 1FL604□ | 4 x M6 | 270 x 270 x 10 (mm) | 8 Nm | Aluminum alloy |
| 1FL606□ | 4 x M8 | 390 x 390 x 15 (mm) | 20 Nm | |
| 1FL609□ | 4 x M12 | 420 x 420 x 20 (mm) | 85 Nm | |

Connecting

4.1 System connection

The SINAMICS V90 servo system is connected as follows:

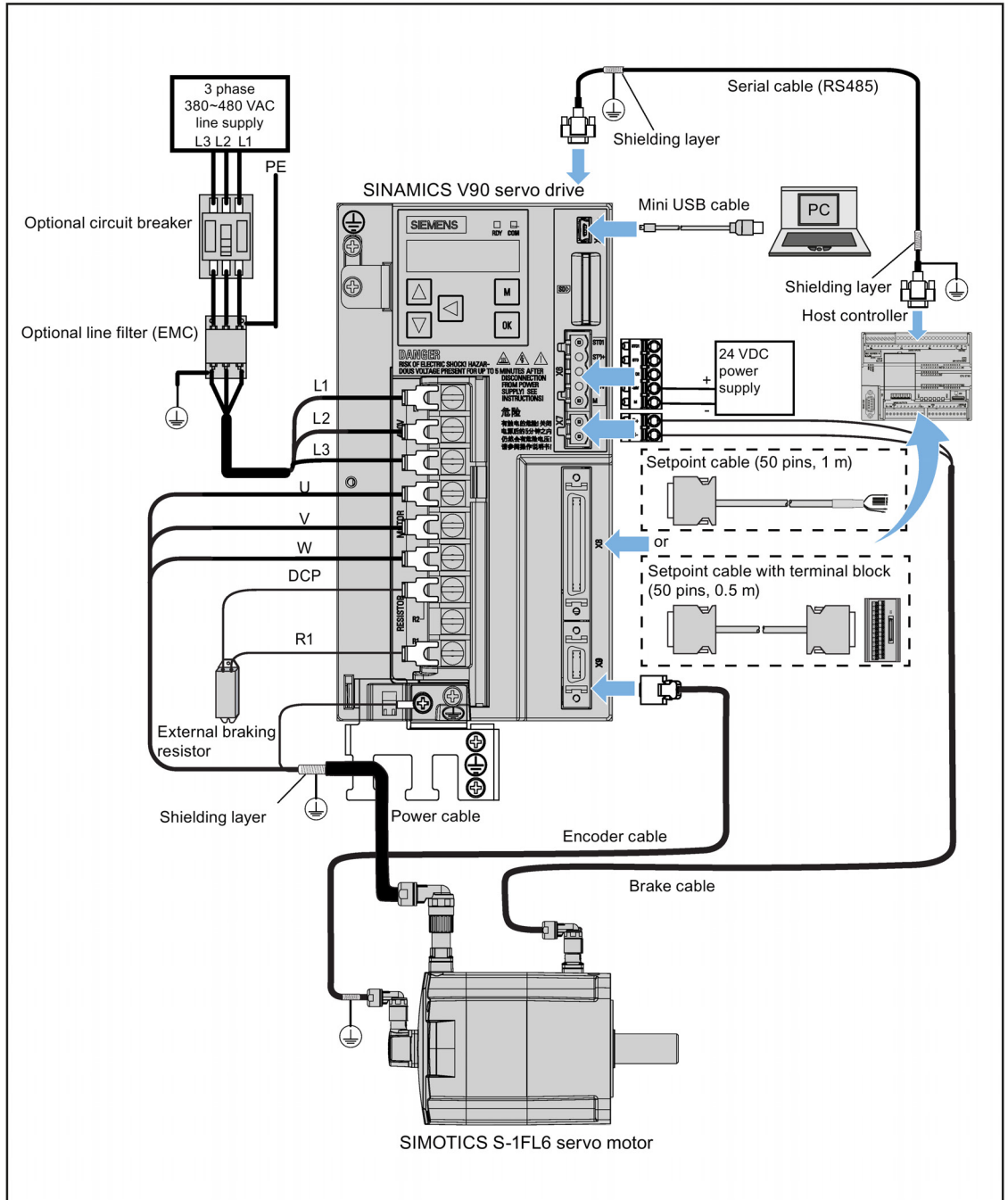

NOTICE

Important wiring information

In order to meet **EMC** requirements, all cables must be shielded cables.

The cable shields of shielded twisted-pair cables should be connected to the shielding plate or the cable clamp of the servo drive.

Connecting the cable shields with the shielding plate

To achieve EMC-compliant installation of the drive, use the shielding plate that is shipped with the drive to connect the cable shields. See the following example for steps to connect cable shields with the shielding plate:

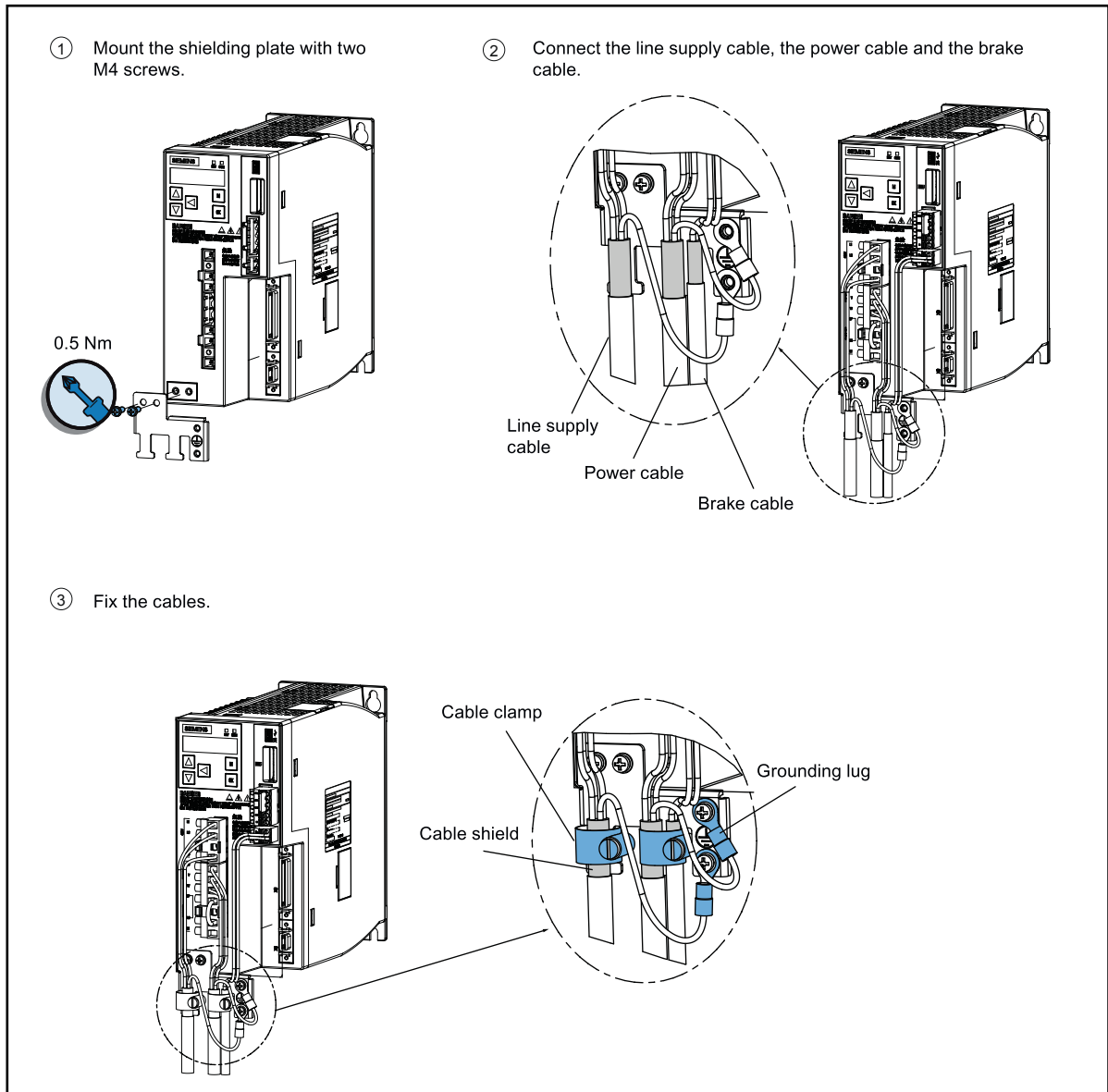

Adjusting cable orientations from the motor side

From the motor side, you can adjust the orientation of the power cable, encoder cable, and brake cable to facilitate cable connection.

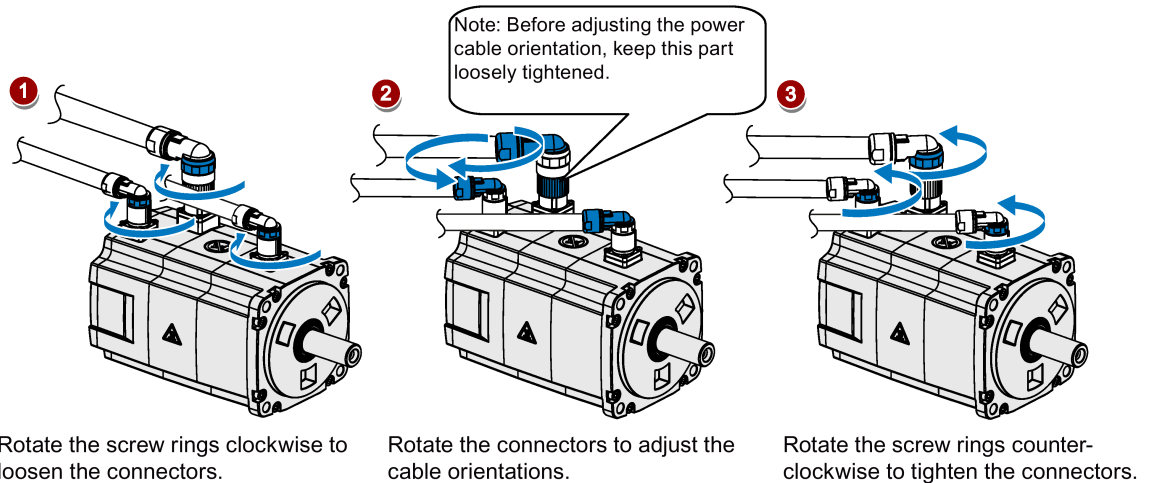

Note

Rotating the connectors

All the three motor-side connectors can be rotated only within 360°.

4.2 Main circuit wirings

4.2.1 Line supply - L1, L2, L3

| Signal | Description |
|---|---------------|
| 400 V variant | |
| L1 | Line phase L1 |
| L2 | Line phase L2 |
| L3 | Line phase L3 |
| Maximum conductor cross-section: FSA and FSA: 1.5 mm ² (M2.5 screws, 0.5 Nm) FSB and FSC: 2.5 mm ² (M4 screws, 2.25 Nm) | |

4.2.2 Motor power - U, V, W

Motor output - drive side

| Signal | Description |
|---|---------------|
| 400 V variant | |
| U | Motor phase U |
| V | Motor phase V |
| W | Motor phase W |
| Maximum conductor cross-section: FSA and FSA: 1.5 mm ² (M2.5 screws, 0.5 Nm) FSB and FSC: 2.5 mm ² (M4 screws, 2.25 Nm) | |

Power connector - motor side

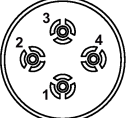
| Illustration | Pin No. | Signal | Description |
|---|---------|--------|---------------------|
|  | 1 | U | Phase U |
| | 2 | V | Phase V |
| | 3 | W | Phase W |
| | 4 | PE | Protective Earthing |

Wiring

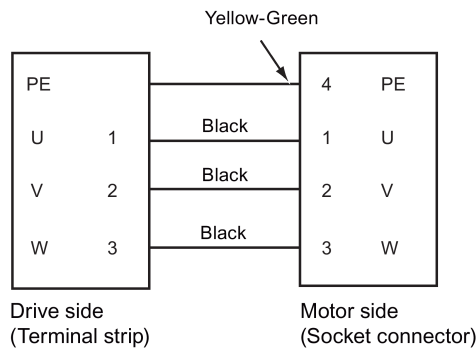

Plugging the motor power cable (FSA and FSA)

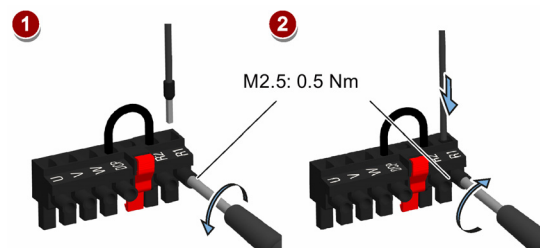

Note

The FSB and FSC servo drives are equipped with barrier terminals for motor power connection. You can fix the motor power cable using the M4 screws with the tightening torque of 2.25 Nm on the servo drives.

4.3 Control/Status interface - X8

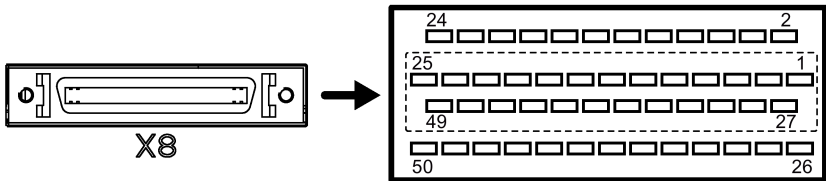
| Signal type | Pin No. | Signal | Description | Pin No. | Signal | Description |
|--|----------------|----------------------------------|--|----------------|-----------|---|
|  <p>Type: 50-pin MDR socket</p> | | | | | | |
| Pulse train inputs (PTI)/Pulse train encoder outputs (PTO) | 1, 2, 26, 27 | | Position setpoint with pulse train input. Exclusive for high-speed 5 V differential pulse train input Maximum frequency: 1MHz Signal transmission of this channel has better noise immunity. | 36, 37, 38, 39 | | Position setpoint with pulse train input. 24 V single end pulse train input Maximum frequency: 200 kHz |
| | 15, 16, 40, 41 | | Encoder emulation pulse output with high-speed 5 V differential signals (A+/A-, B+/B-) | 42, 43 | | Encoder Zero phase pulse output with high-speed 5 V differential signals |
| | 17 | | Encoder Zero phase pulse output with open collector | | | |
| | 1 | PTIA_D+ | High-speed 5 V differential pulse train input A (+) | 15 | PTOA+ | High-speed 5 V differential pulse train encoder output A (+) |
| | 2 | PTIA_D- | High-speed 5 V differential pulse train input A (-) | 16 | PTOA- | High-speed 5 V differential pulse train encoder output A (-) |
| | 26 | PTIB_D+ | High-speed 5 V differential pulse train input B (+) | 40 | PTOB+ | High-speed 5 V differential pulse train encoder output B (+) |
| | 27 | PTIB_D- | High-speed 5 V differential pulse train input B (-) | 41 | PTOB- | High-speed 5 V differential pulse train encoder output B (-) |
| | 36 | PTIA_24P | 24 V pulse train input A, positive | 42 | PTOZ+ | High-speed 5 V differential pulse train encoder output Z (+) |
| | 37 | PTIA_24M | 24 V pulse train input A, ground | 43 | PTOZ- | High-speed 5 V differential pulse train encoder output Z (-) |
| | 38 | PTIB_24P | 24 V pulse train input B, positive | 17 | PTOZ (OC) | Pulse train encoder output Z signal (open collector output) |
| 39 | PTIB_24M | 24 V pulse train input B, ground | | | | |

| Signal type | Pin No. | Signal | Description | Pin No. | Signal | Description |
|-------------------------|---------|--------|------------------------------------|---------|---------|--|
| Digital in-puts/outputs | 3 | DI_COM | Common terminal for digital inputs | 14 | DI10 | Digital input 10 |
| | 4 | DI_COM | Common terminal for digital inputs | 28 | P24V_DO | External 24 V supply for digital outputs |
| | 5 | DI1 | Digital input 1 | 29 | P24V_DO | External 24 V supply for digital outputs |
| | 6 | DI2 | Digital input 2 | 30 | DO1 | Digital output 1 |
| | 7 | DI3 | Digital input 3 | 31 | DO2 | Digital output 2 |
| | 8 | DI4 | Digital input 4 | 32 | DO3 | Digital output 3 |
| | 9 | DI5 | Digital input 5 | 33 | DO4 | Digital output 4 |
| | 10 | DI6 | Digital input 6 | 34 | DO5 | Digital output 5 |
| | 11 | DI7 | Digital input 7 | 35 | DO6 | Digital output 6 |
| | 12 | DI8 | Digital input 8 | 49 | MEXT_DO | External 24 V ground for digital outputs |
| | 13 | DI9 | Digital input 9 | 50 | MEXT_DO | External 24 V ground for digital outputs |
| Analog in-puts/outputs | 18 | P12AI | 12 V power output for analog input | 45 | AO_M | Analog output ground |
| | 19 | AI1+ | Analog input channel 1, positive | 46 | AO1 | Analog output channel 1 |
| | 20 | AI1- | Analog input channel 1, negative | 47 | AO_M | Analog output ground |
| | 21 | AI2+ | Analog input channel 2, positive | 48 | AO2 | Analog output channel 2 |
| | 22 | AI2- | Analog input channel 2, negative | | | |
| None | 23 | - | Reserved | 25 | - | Reserved |
| | 24 | - | Reserved | 44 | - | Reserved |

4.3.1 Digital inputs/outputs (DIs/DOs)

SINAMICS V90 supports free assignment of signals to the following digital input and output terminals depending on the control mode selected:

DI1 to DI8 -- Assignable with parameters p29301 to p29308

DO1 to DO6 -- Assignable with parameters p29330 to p29335

Exception: DI9 and DI10

DI9 is permanently assigned with the signal EMGS (emergency stop) and DI10 is permanently assigned with the signal C-MODE (change mode).

For detailed information about default DI/DO signal assignments, see the table below:

| Pin No. | Digital inputs/outputs | Parameters | Default signals/values | | | |
|---------|------------------------|------------|------------------------|----------------|-------------|-------------|
| | | | Index 0 (PTI) | Index 1 (IPos) | Index 2 (S) | Index 3 (T) |
| 5 | DI1 | p29301 | 1 (SON) | 1 (SON) | 1 (SON) | 1 (SON) |
| 6 | DI2 | p29302 | 2 (RESET) | 2 (RESET) | 2 (RESET) | 2 (RESET) |
| 7 | DI3 | p29303 | 3 (CWL) | 3 (CWL) | 3 (CWL) | 3 (CWL) |
| 8 | DI4 | p29304 | 4 (CCWL) | 4 (CCWL) | 4 (CCWL) | 4 (CCWL) |
| 9 | DI5 | p29305 | 5 (G-CHANGE) | 5 (G-CHANGE) | 12 (CWE) | 12 (CWE) |
| 10 | DI6 | p29306 | 6 (P-TRG) | 6 (P-TRG) | 13 (CCWE) | 13 (CCWE) |
| 11 | DI7 | p29307 | 7 (CLR) | 21 (POS1) | 15 (SPD1) | 18 (TSET) |
| 12 | DI8 | p29308 | 10 (TLIM1) | 22 (POS2) | 16 (SPD2) | 19 (SLIM1) |
| 30 | DO1 | p29330 | 1 (RDY) | | | |
| 31 | DO2 | p29331 | 2 (ALM) | | | |
| 32 | DO3 | p29332 | 3 (INP) | | | |
| 33 | DO4 | p29333 | 5 (SPDR) | | | |
| 34 | DO5 | p29334 | 6 (TLR) | | | |
| 35 | DO6 | p29335 | 8 (MBR) | | | |

Note

The selected DI signal will respond with a delay time of 8 to 16 ms.

4.3.1.1 DIs

You can assign a maximum of 28 internal digital input signals to the SINAMICS V90 servo drive. For detailed information about these signals, see the table below:

| No. | Name | Type | Description | Control mode | | | |
|-----|-------|--------------------|--|--------------|------|---|---|
| | | | | PTI | IPos | S | T |
| 1 | SON | Edge 0→1 1→0 | Servo-on <ul style="list-style-type: none"> 0→1: powers on power circuit and makes servo drive ready to operate. 1→0: motor ramps down (OFF1) in PTI, IPos, and S modes; motor coasts down (OFF2) in T mode. | ✓ | ✓ | ✓ | ✓ |
| 2 | RESET | Edge 0→1 | Reset alarms <ul style="list-style-type: none"> 0→1: Reset alarms | ✓ | ✓ | ✓ | ✓ |
| 3 | CWL | Edge 1→0 | Clockwise over-travel limit (positive limit) <ul style="list-style-type: none"> 1 = condition for operation 1→0: emergency stop (OFF3) | ✓ | ✓ | ✓ | ✓ |

| No. | Name | Type | Description | Control mode | | | |
|-----|----------|----------------------|---|--------------|------|---|---|
| | | | | PTI | IPos | S | T |
| 4 | CCWL | Edge 1→0 | Counter-clockwise over-travel limit (negative limit) <ul style="list-style-type: none"> 1 = condition for operation 1→0: emergency stop (OFF3) | ✓ | ✓ | ✓ | ✓ |
| 5 | G-CHANGE | Level | Gain change between the first and the second gain parameter set. <ul style="list-style-type: none"> 0: the first gain parameter set 1: the second gain parameter set | ✓ | ✓ | ✓ | X |
| 6 | P-TRG | Level Edge 0→1 | In PTI mode: pulse allowable/inhibit. <ul style="list-style-type: none"> 0: operation with pulse train setpoint is possible 1: inhibit the pulse train setpoint In IPos mode: position trigger <ul style="list-style-type: none"> 0→1: starts positioning of selected fixed position setpoint | ✓ | ✓ | X | X |
| 7 | CLR | Level | Clear position control droop pulses. <ul style="list-style-type: none"> 0: no clearing 1: always clear | ✓ | X | X | X |
| 8 | EGEAR1 | Level | Electronic gear. | ✓ | ✓ | X | X |
| 9 | EGEAR2 | Level | A combination of the signals EGEAR1 and EGEAR2 can select four electronic gear ratios. EGEAR2 : EGEAR1 <ul style="list-style-type: none"> 0 : 0: electronic gear ratios 1 0 : 1: electronic gear ratios 2 1 : 0: electronic gear ratios 3 1 : 1: electronic gear ratios 4 | ✓ | ✓ | X | X |
| 10 | TLIM1 | Level | Torque limit selection. | ✓ | ✓ | ✓ | X |
| 11 | TLIM2 | Level | A combination of TLIM1 and TLIM2 can select four torque limit sources (one external torque limit, three internal torque limits). TLIM2 : TLIM1 <ul style="list-style-type: none"> 0 : 0: internal torque limit 1 0 : 1: external torque limit (Analog Input 2) 1 : 0: internal torque limit 2 1 : 1: internal torque limit 3 | | | | |
| 12 | CWE | Level | Enable clockwise rotations. <ul style="list-style-type: none"> 1: Enable clockwise rotation, ramp up 0: Disable clockwise rotation, ramp down | X | X | ✓ | ✓ |
| 13 | CCWE | Level | Enable counter-clockwise rotations. <ul style="list-style-type: none"> 1: Enable counter-clockwise rotation, ramp down 0: Disable counter-clockwise rotation, ramp up | X | X | ✓ | ✓ |

| No. | Name | Type | Description | Control mode | | | |
|-----|---------|-------|--|--------------|------|---|---|
| | | | | PTI | IPos | S | T |
| 14 | ZSCLAMP | Level | Zero speed clamps. <ul style="list-style-type: none"> 1 = when the motor speed setpoint is an analog signal and lower than the threshold level (P_zclamp_threshold), the motor is clamped. 0 = no action | X | X | ✓ | X |
| 15 | SPD1 | Level | Select speed mode: fixed speed setpoint. | X | X | ✓ | X |
| 16 | SPD2 | Level | A combination of the signals SPD1, SPD2 and SPD3 can select eight speed setpoint sources (one external speed setpoint, seven fixed speed setpoints). SPD3 : SPD2 : SPD1 | | | | |
| 17 | SPD3 | Level | | | | | |
| | | | <ul style="list-style-type: none"> 0 : 0 : 0: external analog speed setpoint 0 : 0 : 1: fixed speed setpoint 1 0 : 1 : 0: fixed speed setpoint 2 0 : 1 : 1: fixed speed setpoint 3 1 : 0 : 0: fixed speed setpoint 4 1 : 0 : 1: fixed speed setpoint 5 1 : 1 : 0: fixed speed setpoint 6 1 : 1 : 1: fixed speed setpoint 7 | | | | |
| 18 | TSET | Level | Torque setpoint selection. This signal can select two torque setpoint sources (one external torque setpoint, one fixed torque setpoint). <ul style="list-style-type: none"> 0: external torque setpoint (analog Input 2) 1: fixed torque setpoint | X | X | X | ✓ |
| 19 | SLIM1 | Level | Speed limit selection. | ✓ | ✓ | ✓ | ✓ |
| 20 | SLIM2 | Level | A combination of SLIM1 to SLIM2 can select four speed limit sources (one external speed limit, three internal speed limits). SLIM2 : SLIM1 <ul style="list-style-type: none"> 0 : 0: internal speed limit 1 0 : 1: external speed limit (Analog Input 1) 1 : 0: internal speed limit 2 1 : 1: internal speed limit 2 | | | | |

| No. | Name | Type | Description | Control mode | | | |
|-----|-------|-------------|---|--------------|------|---|---|
| | | | | PTI | IPos | S | T |
| 21 | POS1 | Level | Select position setpoint. | X | ✓ | X | X |
| 22 | POS2 | Level | A combination of the signals POS1 to POS3 can select eight fixed position setpoint sources. POS3 : POS2 : POS1 <ul style="list-style-type: none"> • 0 : 0 : 0: fixed position setpoint 1 • 0 : 0 : 1: fixed position setpoint 2 • 0 : 1 : 0: fixed position setpoint 3 • 0 : 1 : 1: fixed position setpoint 4 • 1 : 0 : 0: fixed position setpoint 5 • 1 : 0 : 1: fixed position setpoint 6 • 1 : 1 : 0: fixed position setpoint 7 • 1 : 1 : 1: fixed position setpoint 8 | X | ✓ | X | X |
| 23 | POS3 | Level | | | | | |
| 24 | REF | Edge 0→1 | Set reference point with digital input or reference cam input for reference approaching mode. <ul style="list-style-type: none"> • 0→1: reference input | X | ✓ | X | X |
| 25 | SREF | Edge 0→1 | The reference approach will be started with the signal SREF. <ul style="list-style-type: none"> • 0→1 start reference approach | X | ✓ | X | X |
| 26 | STEPF | Edge 0→1 | Step forward to the next fixed position setpoint. <ul style="list-style-type: none"> • 0→1 start step action | X | ✓ | X | X |
| 27 | STEPB | Edge 0→1 | Step backward to the previous fixed position setpoint. <ul style="list-style-type: none"> • 0→1 start step action | X | ✓ | X | X |
| 28 | STEPH | Edge 0→1 | Step to the fixed position setpoint 1. <ul style="list-style-type: none"> • 0→1 start step action | X | ✓ | X | X |

Note

When working in the torque control mode, the torque setpoint equals to 0 if CWE and CCWE are at the same status. For more information, please refer to section Direction and stop (Page 172).

Note

Invalid circumstances for DI signals

- All DI signals except for EMGS are invalid during parameter saving.
- All DI signals except for CWL, CCWL, and EMGS are invalid during auto tuning.
- When SINAMICS V-ASSISTANT is communicating with the drive or you are operating the drive on SINAMICS V-ASSISTANT, some DI signals are invalid:
 - When referencing by SINAMICS V-ASSISTANT, the DI signal SREF is invalid.
 - During trial run test, the DI signal SON is invalid; meanwhile, DI7 and DI8 are occupied by SINAMICS V-ASSISTANT.

Direct signal map

Force the following six signals to logical "1" with parameter p29300 (P_DI_Mat):

- SON
- CWL
- CCWL
- TLIM1
- SPD1
- TSET

The definition for p29300 is as follows:

| Bit 5 | Bit 4 | Bit 3 | Bit 2 | Bit 1 | Bit 0 |
|-------|-------|-------|-------|-------|-------|
| TSET | SPD1 | TLIM1 | CCWL | CWL | SON |

For example, if you set p29300 = 1 to force the signal SON to a logical high signal, DI1 can then be assigned to other desired signals.

Note

The parameter p29300 has higher priority than the DIs.

Wiring

The digital inputs support both PNP and NPN types of wirings. You can find detailed information from the following diagrams:

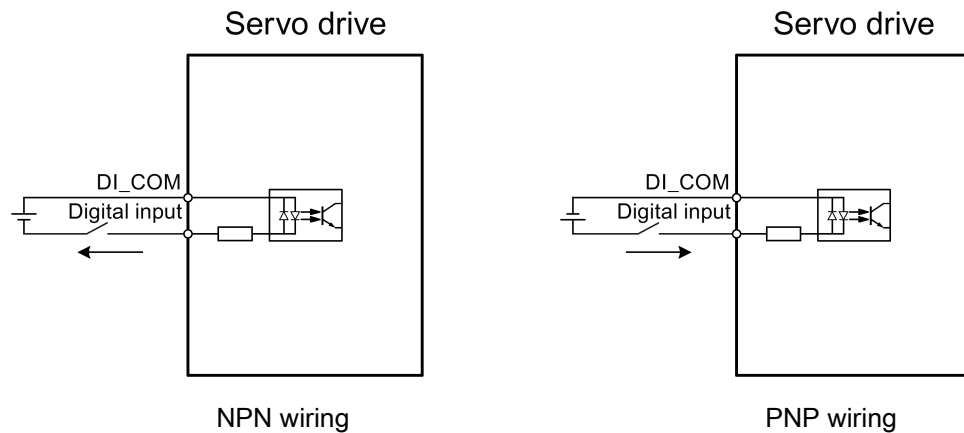

4.3.1.2 DOs

You can assign a maximum of 13 internal digital output signals to the SINAMICS V90 servo drive. For detailed information about these signals, see the table below:

| No. | Name | Descriptions | Control mode | | | |
|-----|------|--|--------------|------|---|---|
| | | | PTI | IPos | S | T |
| 1 | RDY | Servo ready <ul style="list-style-type: none"> 1: ready to operate 0: drive not ready (alarm occurs or enable signal is missing) | ✓ | ✓ | ✓ | ✓ |
| 2 | ALM | Alarm <ul style="list-style-type: none"> 1: in alarm status 0: no alarm | ✓ | ✓ | ✓ | ✓ |
| 3 | INP | In-position signal <ul style="list-style-type: none"> 1: number of droop pulses is in the preset in-position range (parameter p2544) 0: droop pulses are beyond the in-position range | ✓ | ✓ | X | X |
| 4 | ZSP | Zero speed detection <ul style="list-style-type: none"> 1: motor speed is equal with or lower than the zero speed (can be set with parameter P_z_spd). 0: motor speed is higher than zero speed + hysteresis (10 rpm). | ✓ | ✓ | ✓ | ✓ |
| 5 | SPDR | Speed reached <ul style="list-style-type: none"> 1: motor actual speed has nearly (internal hysteresis 10 rpm) reached the speed of the internal speed command or analog speed command. The speed approaching range can be set via parameter (P_at_spd) 0: speed difference between speed setpoint and actual is larger than internal hysteresis. | X | X | ✓ | X |
| 6 | TLR | Torque limit reached <ul style="list-style-type: none"> 1: the generated torque has nearly (internal hysteresis) reached the value of the positive torque limit, negative torque limit or analog torque limit 0: the generated torque has not reached the limit | X | X | ✓ | X |
| 7 | SPLR | Speed limit reached <ul style="list-style-type: none"> 1: the speed has nearly (internal hysteresis, 10 rpm) reached the speed limit. 0: the speed has not reached the speed limit. | ✓ | ✓ | ✓ | X |

| No. | Name | Descriptions | Control mode | | | |
|-----|----------|--|--------------|------|---|---|
| | | | PTI | IPos | S | T |
| 8 | MBR | Motor holding brake <ul style="list-style-type: none"> 1: motor holding brake is closed 0: motor holding brake is released Note: MBR is only status signal because the control and the power supply of the motor holding brake is realized with separate terminals. | ✓ | ✓ | ✓ | ✓ |
| 9 | OLL | Overload level reached <ul style="list-style-type: none"> 1: motor has reached the parameterizable output overload level (P_overload_level in % of rated torque, default: 100%, max: 300%) 0: motor has not reached the overload level | ✓ | ✓ | ✓ | ✓ |
| 10 | WARNING1 | Warning 1 condition reached <ul style="list-style-type: none"> 1: parameterizable warning 1 condition has been reached. 0: warning 1 condition has not been reached. See note below. | ✓ | ✓ | ✓ | ✓ |
| 11 | WARNING2 | Warning 2 condition reached <ul style="list-style-type: none"> 1: parameterizable warning 2 condition has been reached 0: warning 2 condition has not been reached. See note below | ✓ | ✓ | ✓ | ✓ |
| 12 | REFOK | Referenced <ul style="list-style-type: none"> 1 = Referenced 0 = Not referenced | X | ✓ | X | X |
| 13 | CM_STA | Current control mode <ul style="list-style-type: none"> 1 = The second mode in five compound control modes (PTI/S, IPos/S, PTI/T, IPos/T, S/T) 0 = The first mode in five compound control modes or four basic modes (PTI, IPos, S, T) | ✓ | ✓ | ✓ | ✓ |

Assigning warning signals to digital outputs

You can assign two groups of warning signals to digital outputs with parameters p29340 (first group of warning signals active) and p29341 (second group of warning signals active).

| Setting (p29340/p29341) | Warning conditions |
|-------------------------|--|
| 1 | Overload protection: load factor is 85% of or above the motor utilization. |
| 2 | Braking resistor: capacity of the braking resistor is 85% of or above the resistor power rating. |
| 3 | Fan alarm: fan has stopped for 1 second or longer. |
| 4 | Encoder alarm |
| 5 | Motor overheat: motor has reached 85% of the maximum allowed motor temperature. |
| 6 | Lifetime detection: the life expectancy of the capacity or the fan is shorter than the specified time. |

If warning condition assigned to p29340 occurs, WARNING1 becomes ON.

If warning condition assigned to p29341 occurs, WARNING2 becomes ON.

Wiring

The digital outputs only support NPN type of wiring as illustrated below:

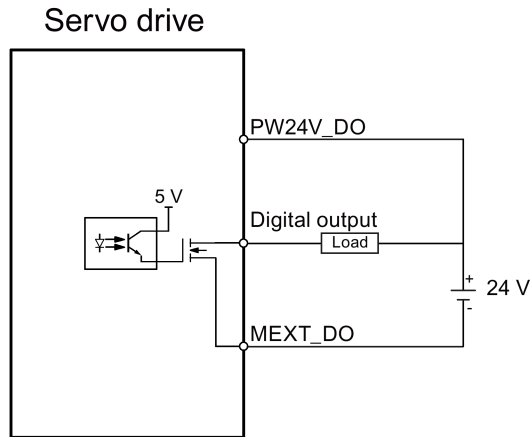

4.3.2 Pulse train inputs/encoder outputs (PTIs/PTOs)

4.3.2.1 PTIs

Two channels of pulse train input are available for the SINAMICS V90 servo drive:

- 24 V single end pulse train input
- High-speed 5 V differential pulse train input

When using the 24 V single end PTI:

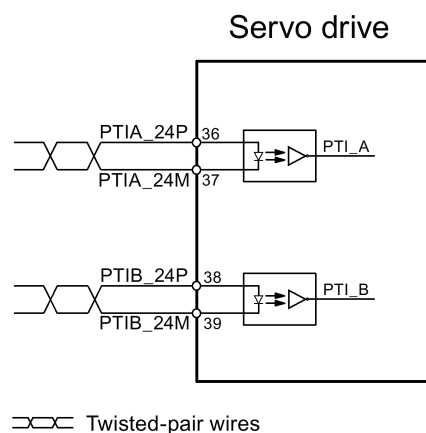

When using the 5 V differential PTI:

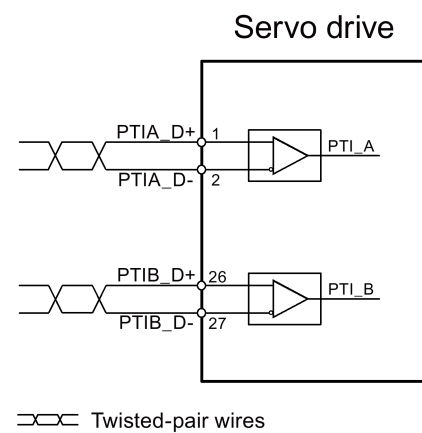

Note

Only one channel can be used. The 24 V single end PTI is the factory setting of the SINAMICS V90 servo drives.

When you choose to use the high-speed 5 V differential PTI, you must change the value of parameter p29014 from 1 to 0. Refer to "Selecting a setpoint pulse train input channel (Page 135)".

4.3.2.2 PTOs

High-speed 5 V differential signals (A+/A-, B+/B-, Z+/Z-) and open collector (zero pulse) are supported.

Wirings

When not using the open collector:

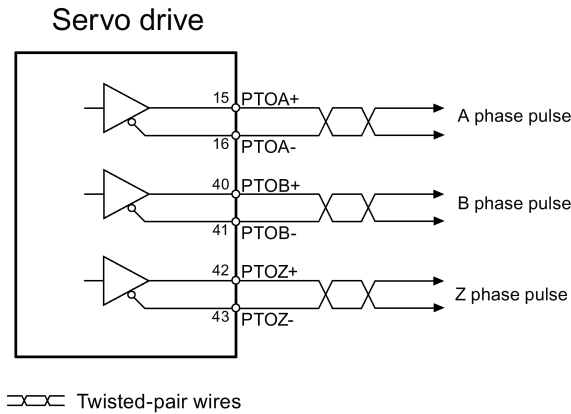

When using the open collector:

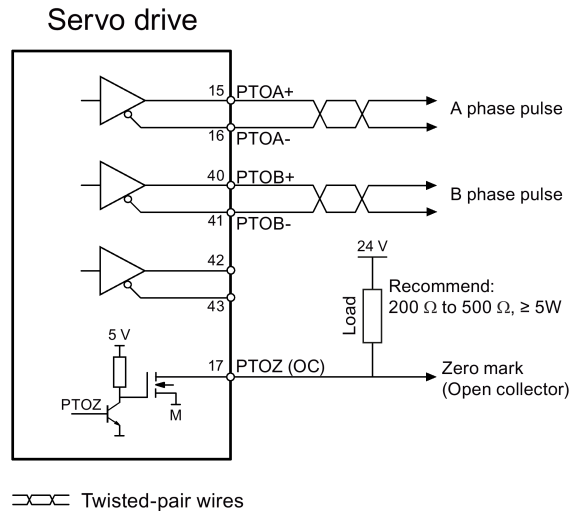

4.3.3 Analog inputs/outputs (AIs/AOs)

4.3.3.1 AIs

SINAMICS V90 has two analog input terminals. The input voltage at each analog input varies with control modes.

| Pin No. | Analog input | Input voltage | Control mode | Function |
|---------|----------------|----------------|--------------|-------------------------------------|
| 19 | Analog input 1 | 0 V to 10 V | PTI | Not used |
| | | 0 V to 10 V | IPos | Not used |
| 20 | | -10 V to +10 V | S | Speed setpoint (reference p29060) * |
| | | 0 V to 10 V | T | Speed limit (reference p29060) * |
| 21 | Analog input 2 | 0 V to 10 V | PTI | Torque limit (reference r0333) |
| | | 0 V to 10 V | IPos | Torque limit (reference r0333) |

| Pin No. | Analog input | Input voltage | Control mode | Function |
|---------|--------------|----------------|--------------|-----------------------------------|
| 22 | | 0 V to 10 V | S | Torque limit (reference r0333) |
| | | -10 V to +10 V | T | Torque setpoint (reference r0333) |

* If the AI input voltage is higher than 10 V, the speed is not limited to the value at 10 V (p29060), but scaled according to p29060. For example, if p29060 = 3000 rpm, the speed is 3300 rpm at 11 V and 3600 rpm at 12 V.

Command voltage

The command voltage of the analog inputs always follows the formula below:

$$V_{\text{input}} = (\text{AI}+) - (\text{AI}-)$$

4.3.3.2 AOs

The SINAMICS V90 has two analog outputs. You can find detailed information about these two analog outputs from the table below:

| Pin No. | Analog output | Output voltage | Function |
|---------|-----------------|----------------|--------------------------------|
| 46 | Analog output 1 | -10 V to +10 V | Analog output 1 for monitoring |
| 48 | Analog output 2 | -10 V to +10 V | Analog output 2 for monitoring |

Parameterization

Two parameters, p29350 (selects signal sources for AO1) and p29351 (selects signal sources for AO2), are used to select the source of analog output:

| Parameter | Value | Source | Value | Source |
|-----------|-------------|--|-------|---|
| p29350 | 0 (default) | Actual speed (reference p29060) | 7 | Pulse input frequency (reference 100 k) |
| | 1 | Actual torque (reference 3 × r0333) | 8 | Pulse input frequency (reference 1000 k) |
| | 2 | Speed setpoint (reference p29060) | 9 | Remaining number of pulses (reference 1 k) |
| | 3 | Torque setpoint (reference 3 × r0333) | 10 | Remaining number of pulses (reference 10 k) |
| | 4 | DC bus voltage (reference 1000 V) | 11 | Remaining number of pulses (reference 100 k) |
| | 5 | Pulse input frequency (reference 1 k) | 12 | Remaining number of pulses (reference 1000 k) |
| | 6 | Pulse input frequency (reference 10 k) | | |
| p29351 | 0 | Actual speed (reference p29060) | 7 | Pulse input frequency (reference 100 k) |
| | 1 (default) | Actual torque (reference 3 × r0333) | 8 | Pulse input frequency (reference 1000 k) |
| | 2 | Speed setpoint (reference p29060) | 9 | Remaining number of pulses (reference 1 k) |
| | 3 | Torque setpoint (reference 3 × r0333) | 10 | Remaining number of pulses (reference 10 k) |
| | 4 | DC bus voltage (reference 1000 V) | 11 | Remaining number of pulses (reference 100 k) |
| | 5 | Pulse input frequency (reference 1 k) | 12 | Remaining number of pulses (reference 1000 k) |
| | 6 | Pulse input frequency (reference 10 k) | | |

Wiring

Do wiring of analog outputs as follows:

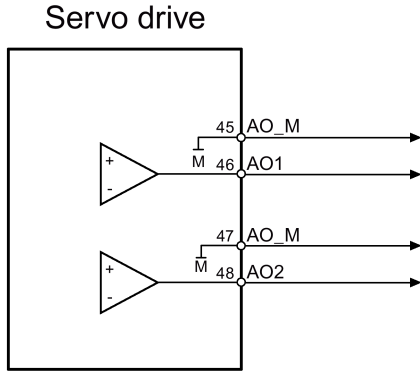

4.3.4 Standard application wirings (factory setting)

4.3.4.1 Pulse train input position control (PTI)

Standard wiring for pulse train input position control mode:

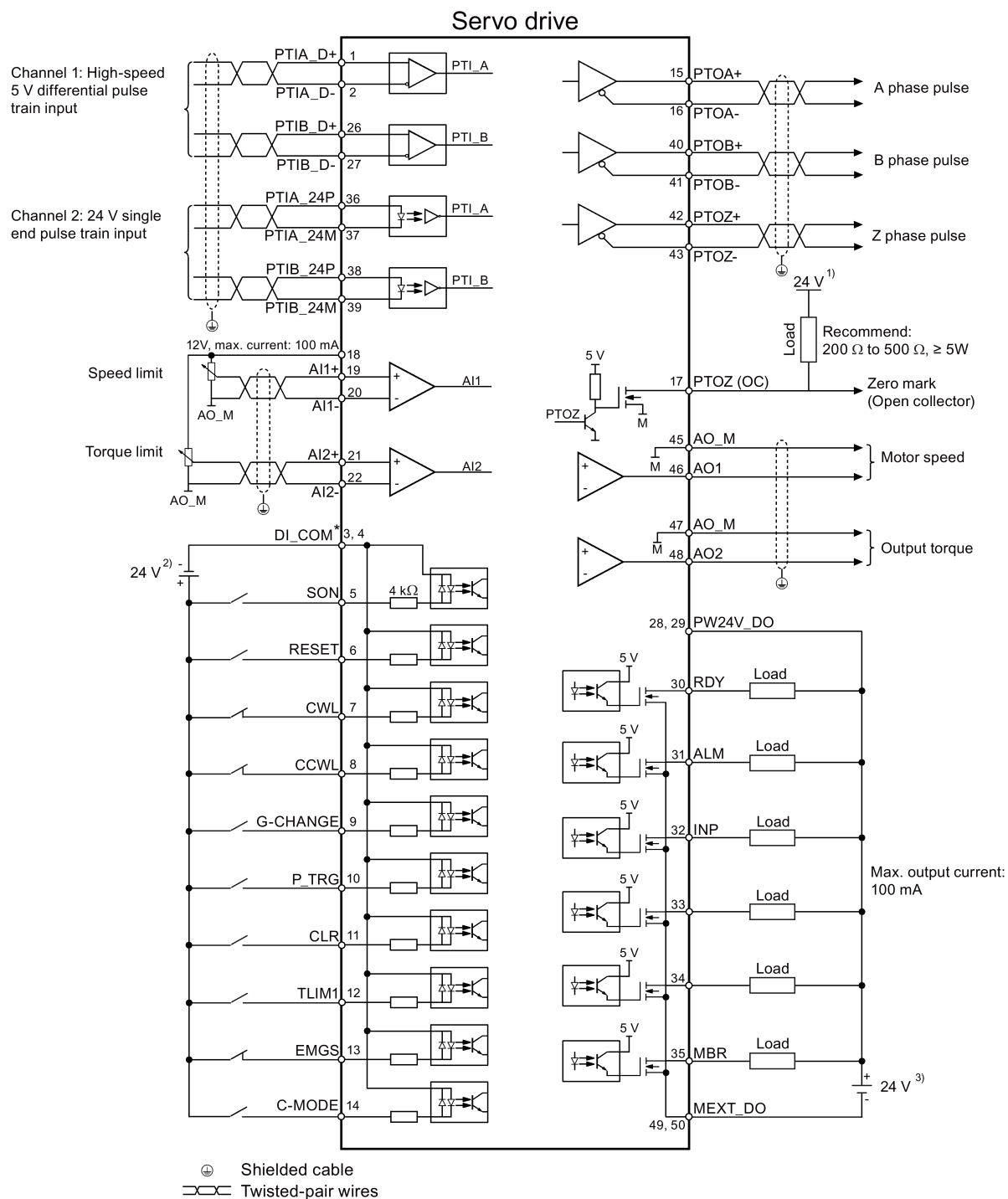

- * Digital inputs, supporting both PNP and NPN types.

The 24 V power supplies in the connection diagram are as follows:

- 1) 24 V power supply for SINAMICS V90. All the PTO signals must be connected to the controller with the same 24 V power supply as SINAMICS V90.
- 2) Isolated digital input power supply. It can be the controller power supply.
- 3) Isolated digital output power supply. It can be the controller power supply.

Note

Only one of the pulse train input channels can be used.

4.3.4.2 Internal position control (IPos)

Standard wiring for internal position control mode:

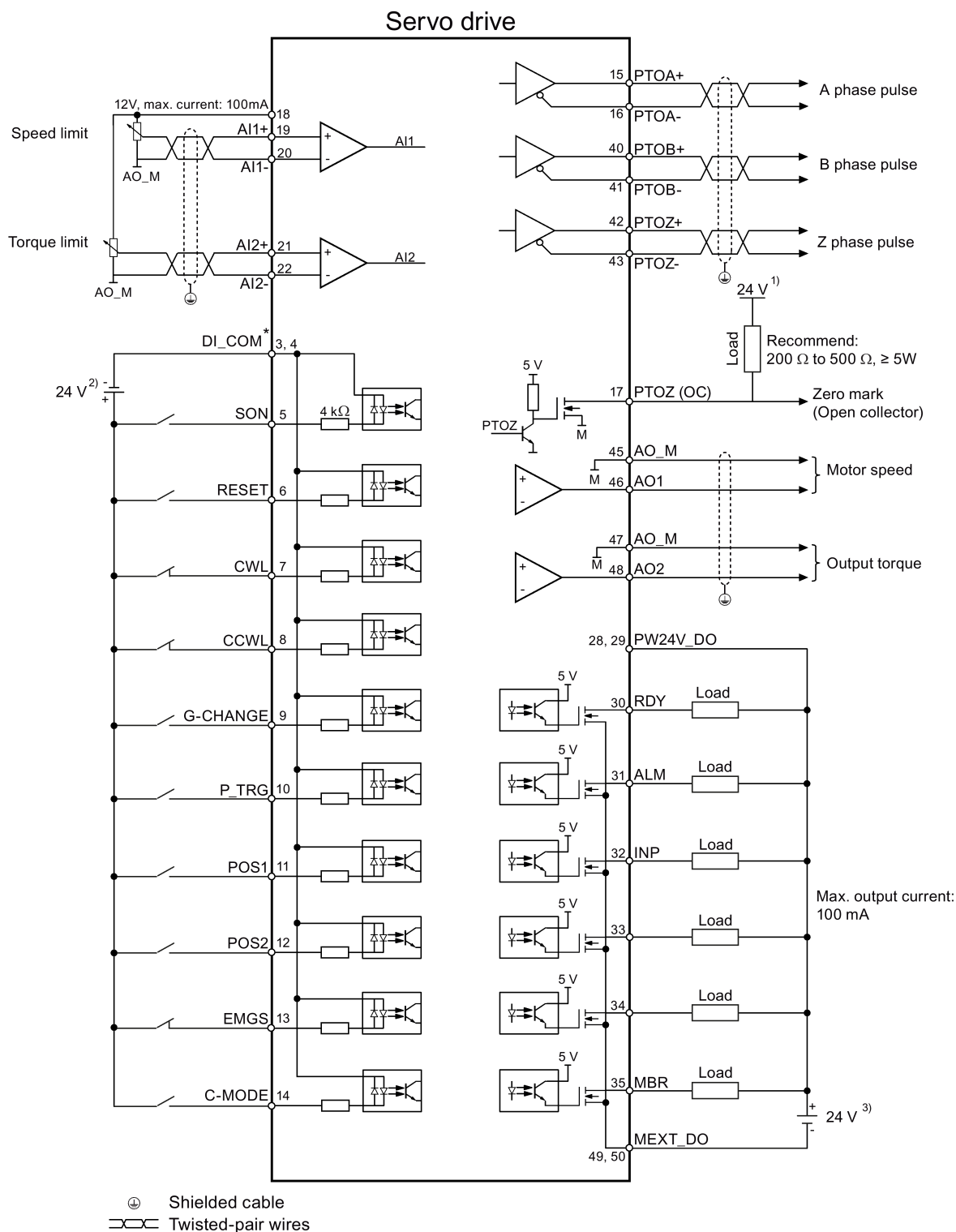

- * Digital inputs, supporting both PNP and NPN types.

The 24 V power supplies in the connection diagram are as follows:

- 1) 24 V power supply for SINAMICS V90. All the PTO signals must be connected to the controller with the same 24 V power supply as SINAMICS V90.
- 2) Isolated digital input power supply. It can be the controller power supply.
- 3) Isolated digital output power supply. It can be the controller power supply.

4.3.4.3 Speed control (S)

Standard wiring for speed control mode:

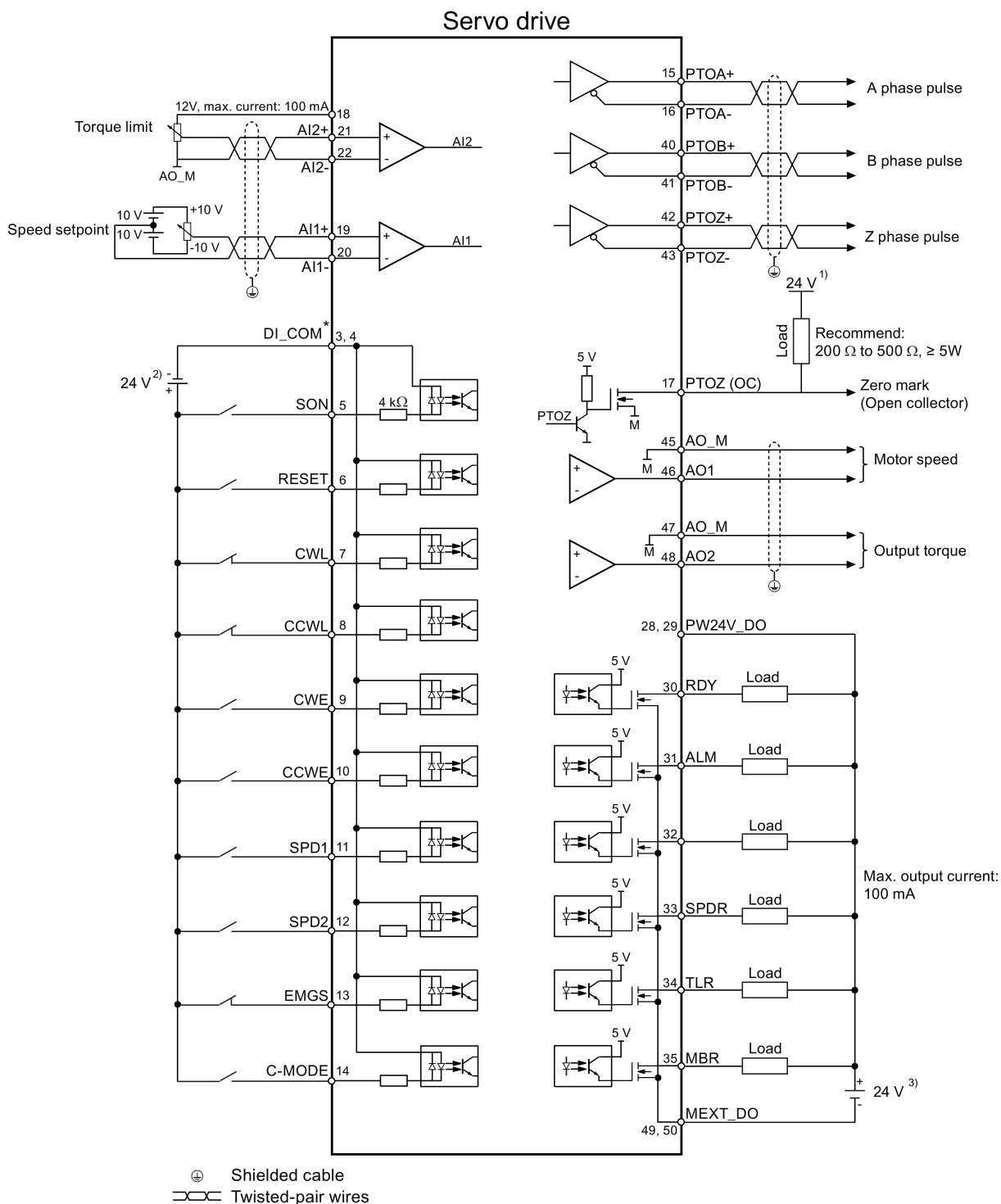

- * Digital inputs, supporting both PNP and NPN types.

The 24 V power supplies in the connection diagram are as follows:

- 1) 24 V power supply for SINAMICS V90. All the PTO signals must be connected to the controller with the same 24 V power supply as SINAMICS V90.
- 2) Isolated digital input power supply. It can be the controller power supply.
- 3) Isolated digital output power supply. It can be the controller power supply.

Note

The analog outputs to analog inputs on the servo unit and the 24V input for the servo unit **must** use a common ground (M).

4.3.4.4 Torque control (T)

Standard wiring for torque control mode:

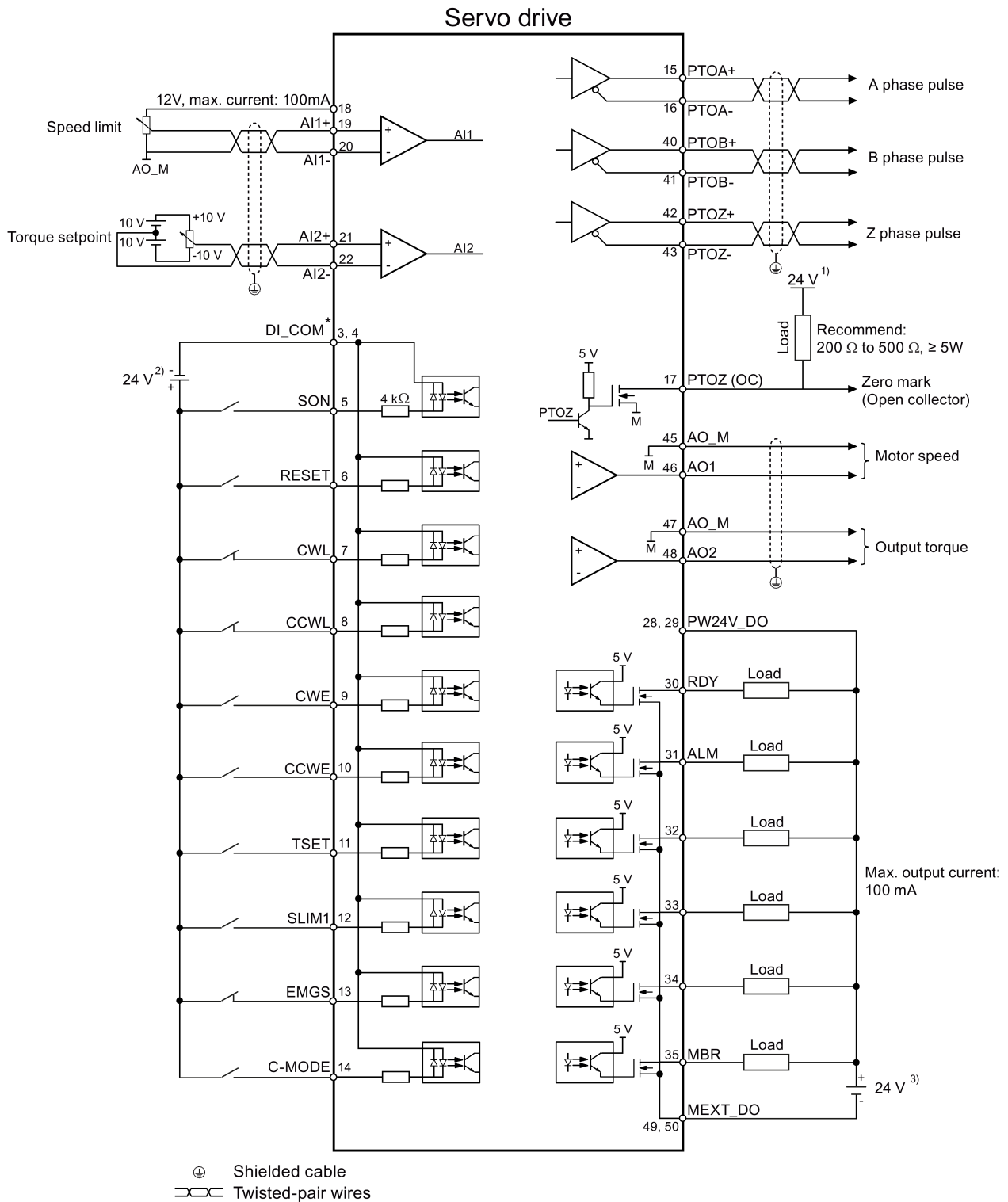

- * Digital inputs, supporting both PNP and NPN types.

The 24 V power supplies in the connection diagram are as follows:

- 1) 24 V power supply for SINAMICS V90. All the PTO signals must be connected to the controller with the same 24 V power supply as SINAMICS V90.
- 2) Isolated digital input power supply. It can be the controller power supply.
- 3) Isolated digital output power supply. It can be the controller power supply.

Note

The analog outputs to analog inputs on the servo unit and the 24V input for the servo unit **must** use a common ground (M).

4.3.5 Connection examples with PLCs

This section gives examples of connections between the drive and the PLC. All of the connection examples shown in this section are made based on factory default settings for digital inputs/outputs.

4.3.5.1 SIMATIC S7-200 SMART

- Pulse train input position control (PTI)

When connect to different axes, the outputs are different. The diagram below take the connection with axis 0 as example.

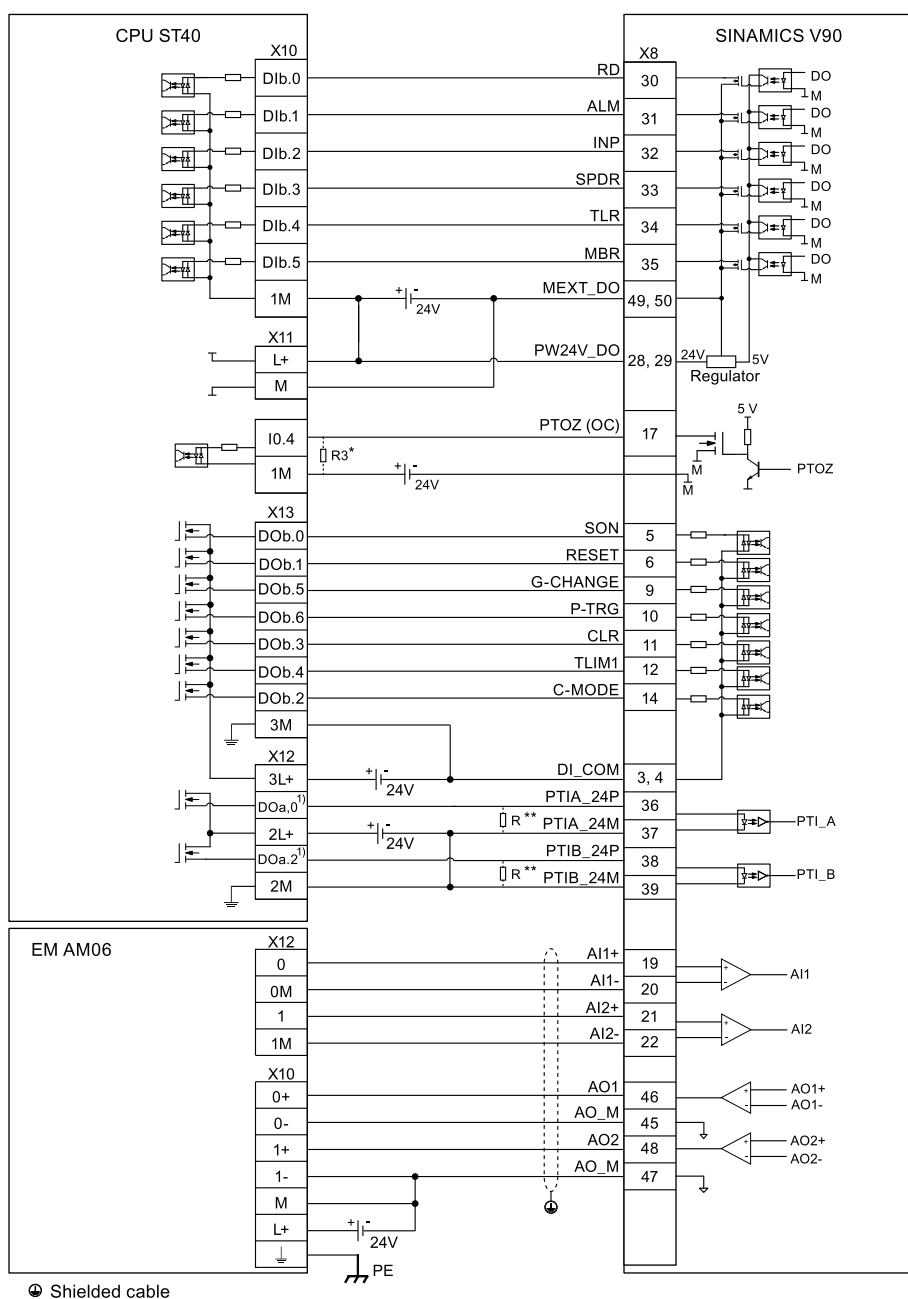

- 1) When connect to axis 1, the outputs are DO a.1 and DO a.7;
When connect to axis 2, the outputs are DO a.3 and DO b.0.
- * The resistor R3 (200 Ohm to 500 Ohm) is required only if the speed for searching the zero position exceeds 300 rpm.
- ** The resistor R (200 Ohm to 500 Ohm, recommended power $\geq 5 W$) is required only if the PTI input frequency exceeds 100 KHz.
- Internal position control (IPos)

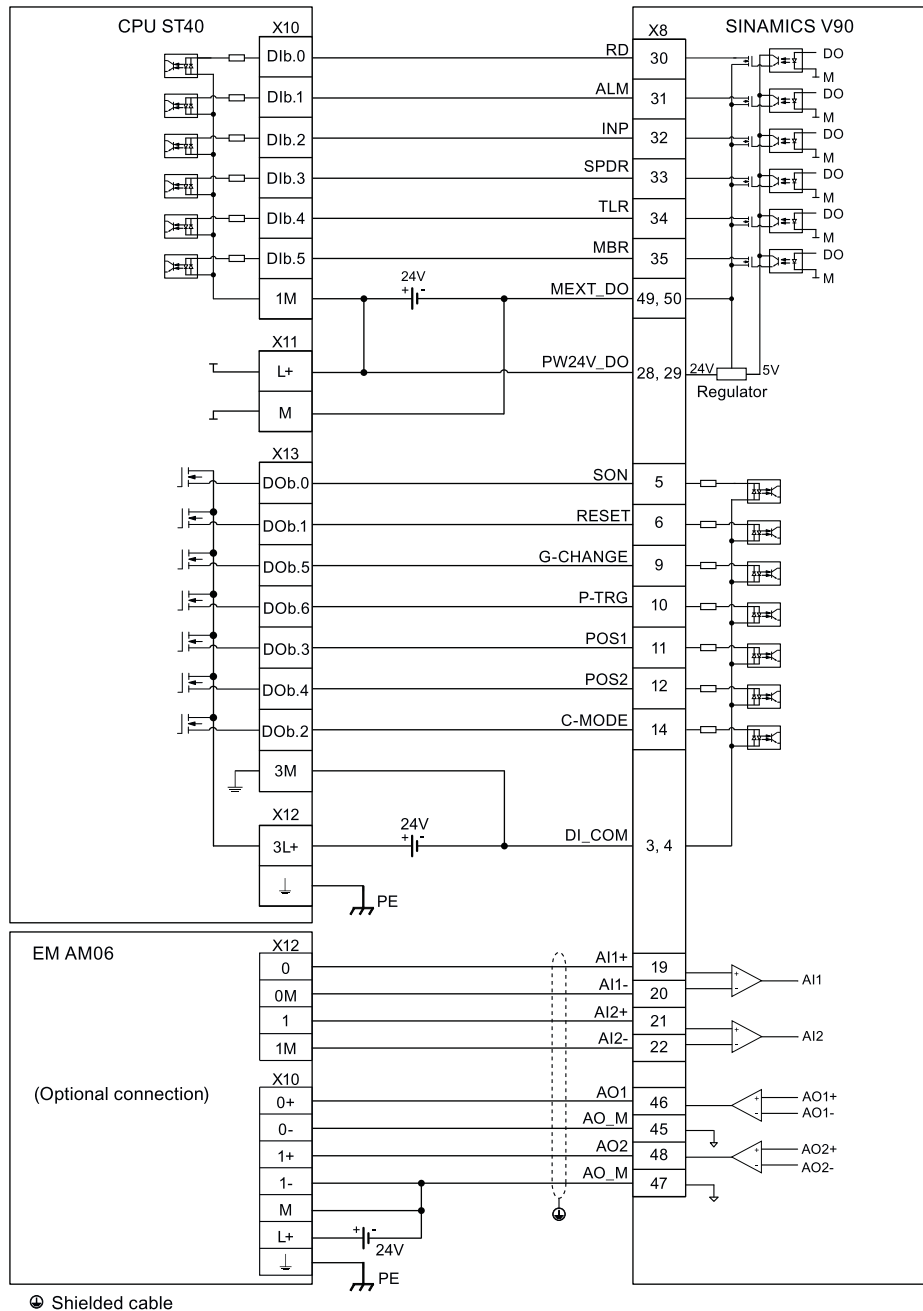

- Speed control (S)

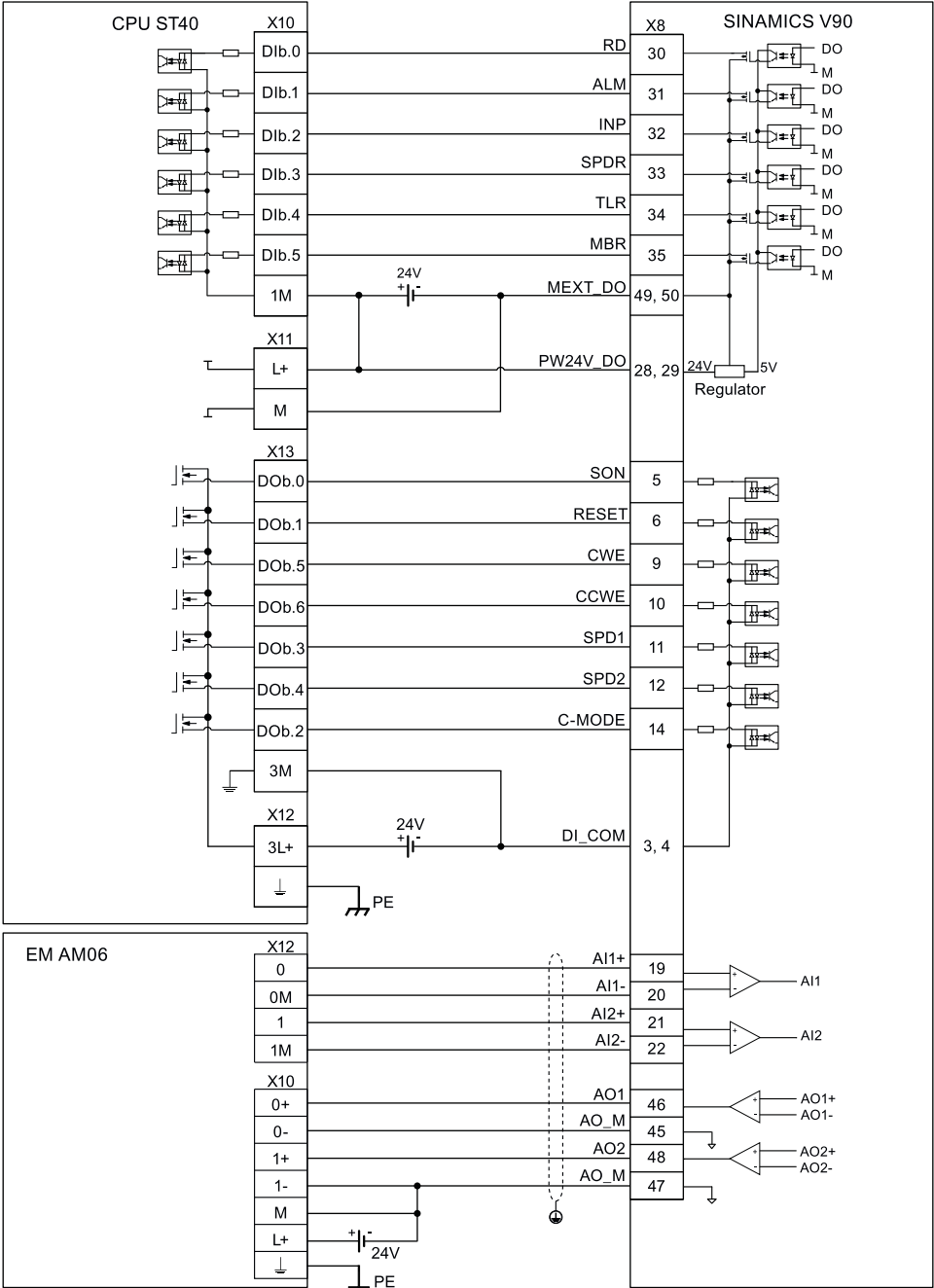

Ⓢ Shielded cable

- Torque control (T)

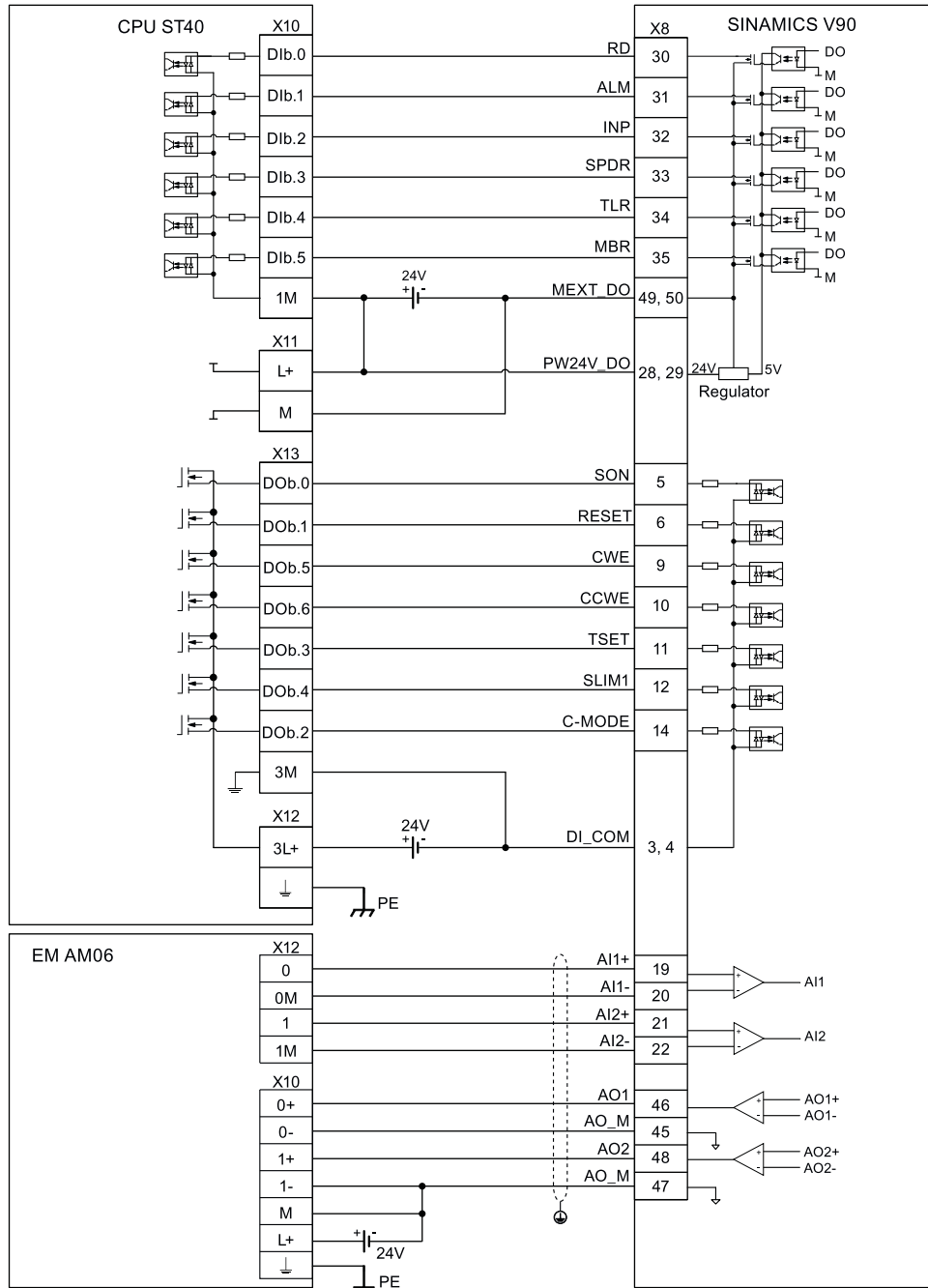

⊕ Shielded cable

4.3.5.2 SIMATIC S7-200

- Pulse train input position control (PTI)

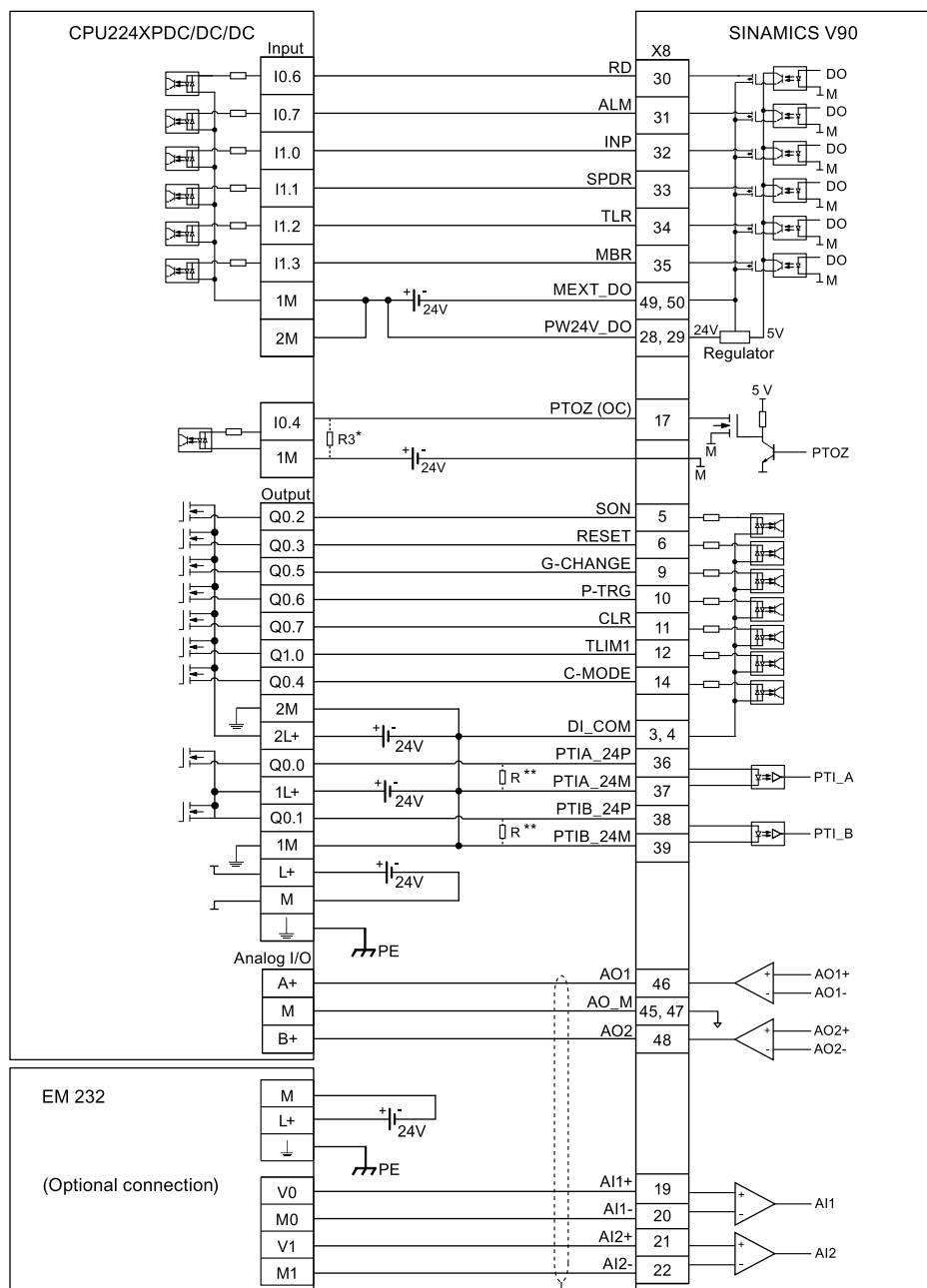

⊕ Shielded cable

- * The resistor R3 (200 Ohm to 500 Ohm) is required only if the speed for searching the zero position exceeds 300 rpm.
- ** The resistor R (200 Ohm to 500 Ohm, recommended power ≥ 5 W) is required only if the PTI input frequency exceeds 100 KHz.

- Internal position control (IPos)

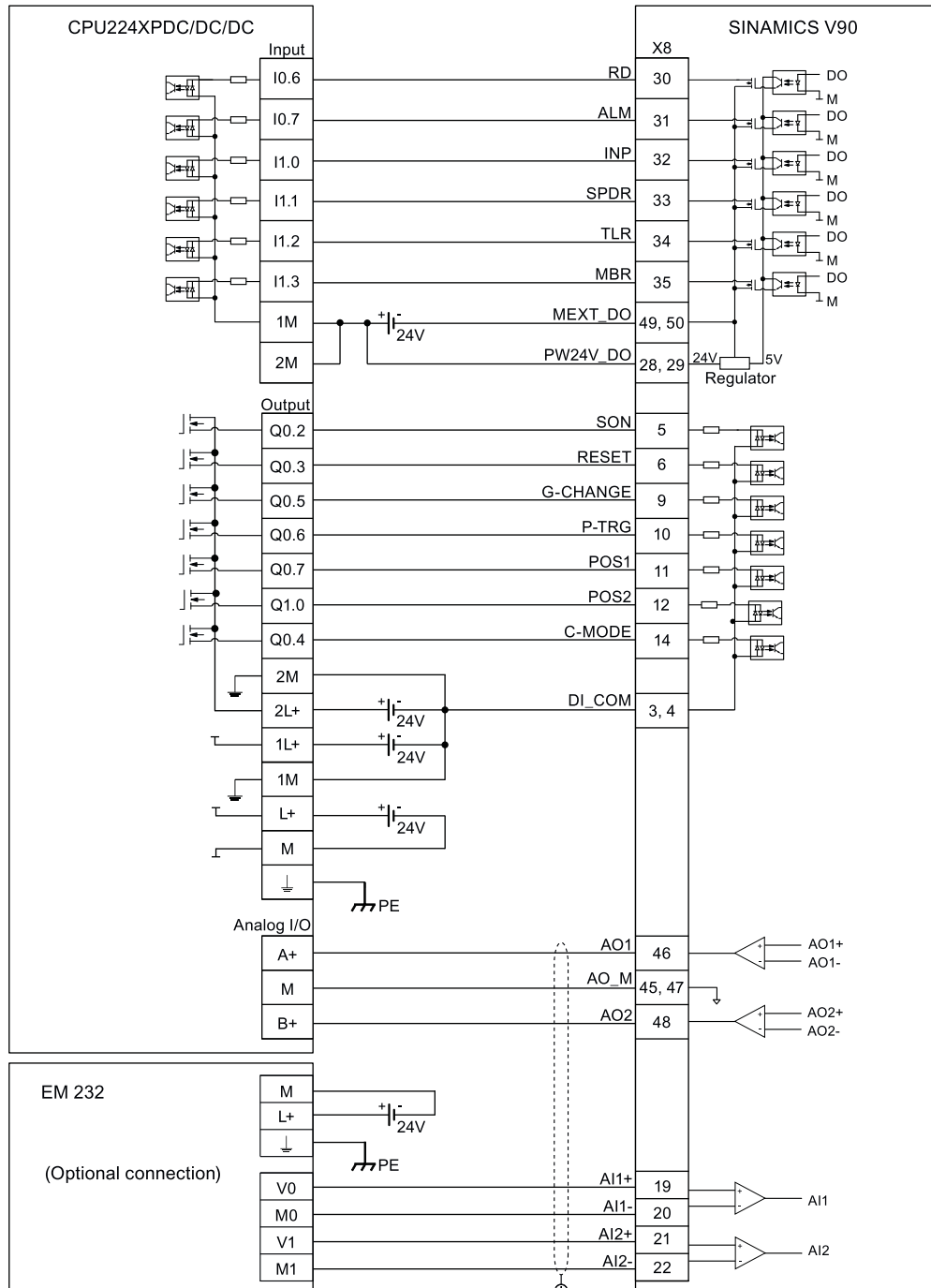

⊕ Shielded cable

- Speed control (S)

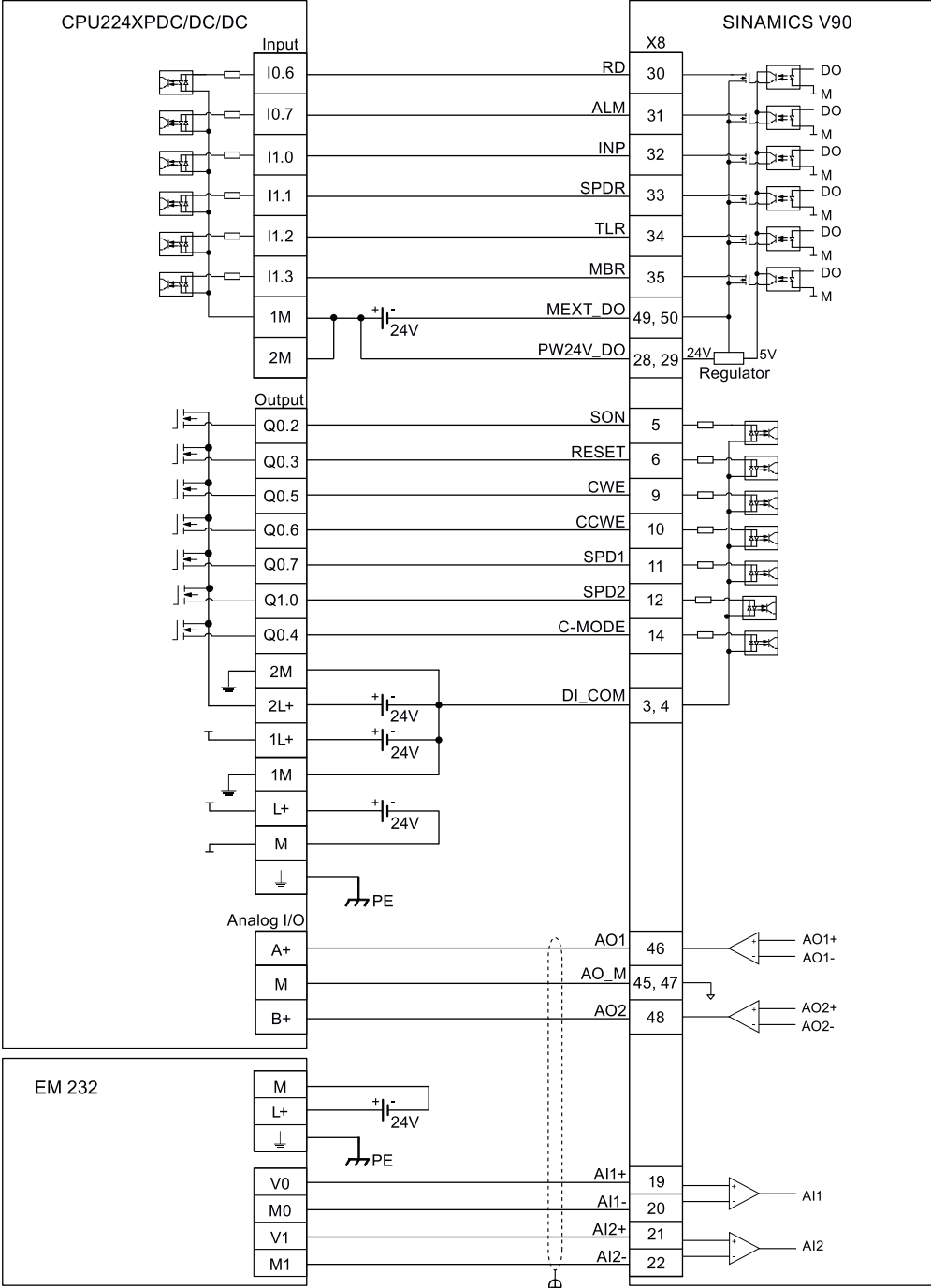

- Torque control (T)

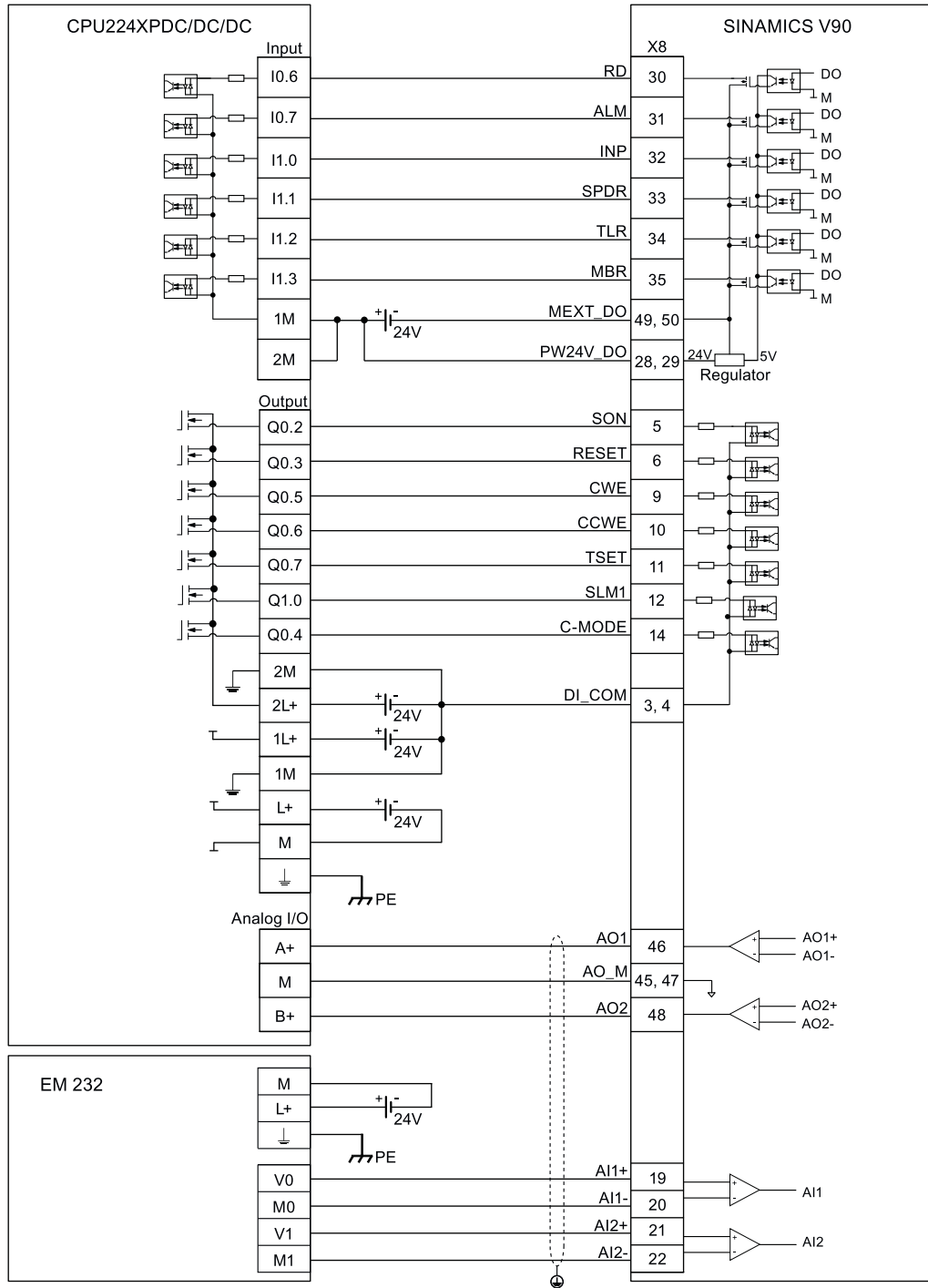

⊕ Shielded cable

4.3.5.3 SIMATIC S7-1200

- Pulse train input position control (PTI)

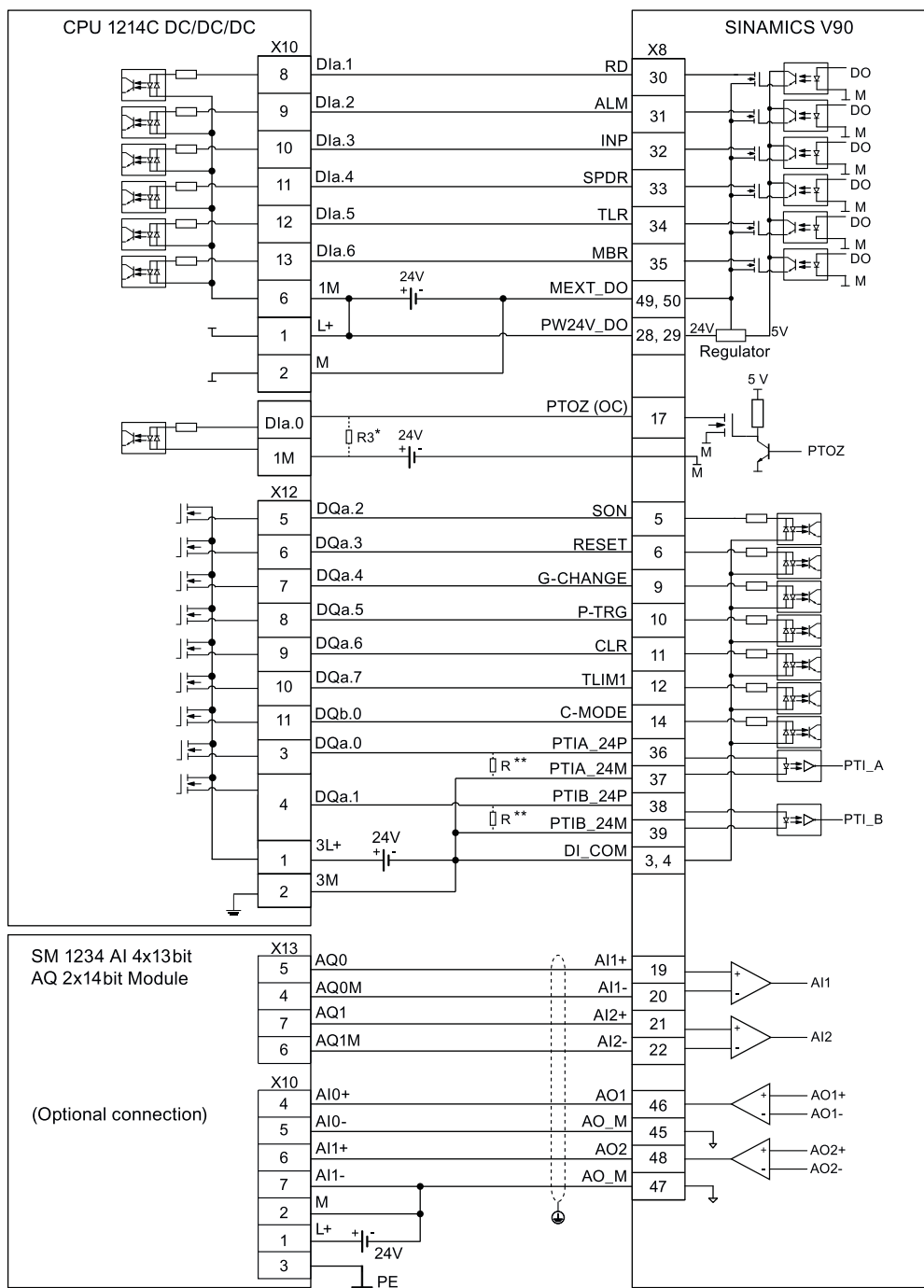

⊕ Shielded cable

* The resistor R3 (200 Ohm to 500 Ohm) is required only if the speed for searching the zero position exceeds 300 rpm.

** The resistor R (200 Ohm to 500 Ohm, recommended power ≥ 5 W) is required only if the PTI input frequency exceeds 100 KHz.

- Internal position control (IPos)

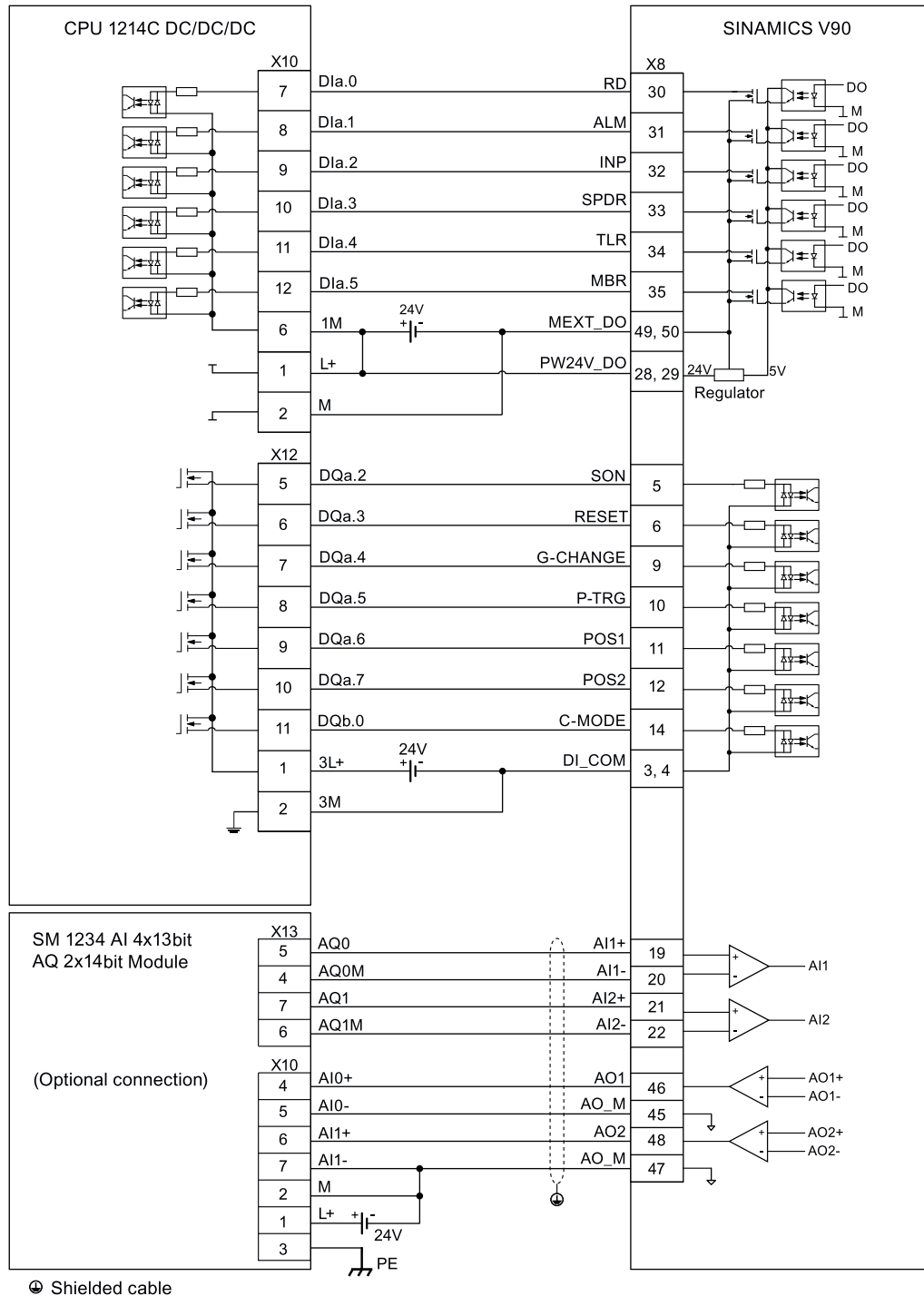

- Speed control (S)

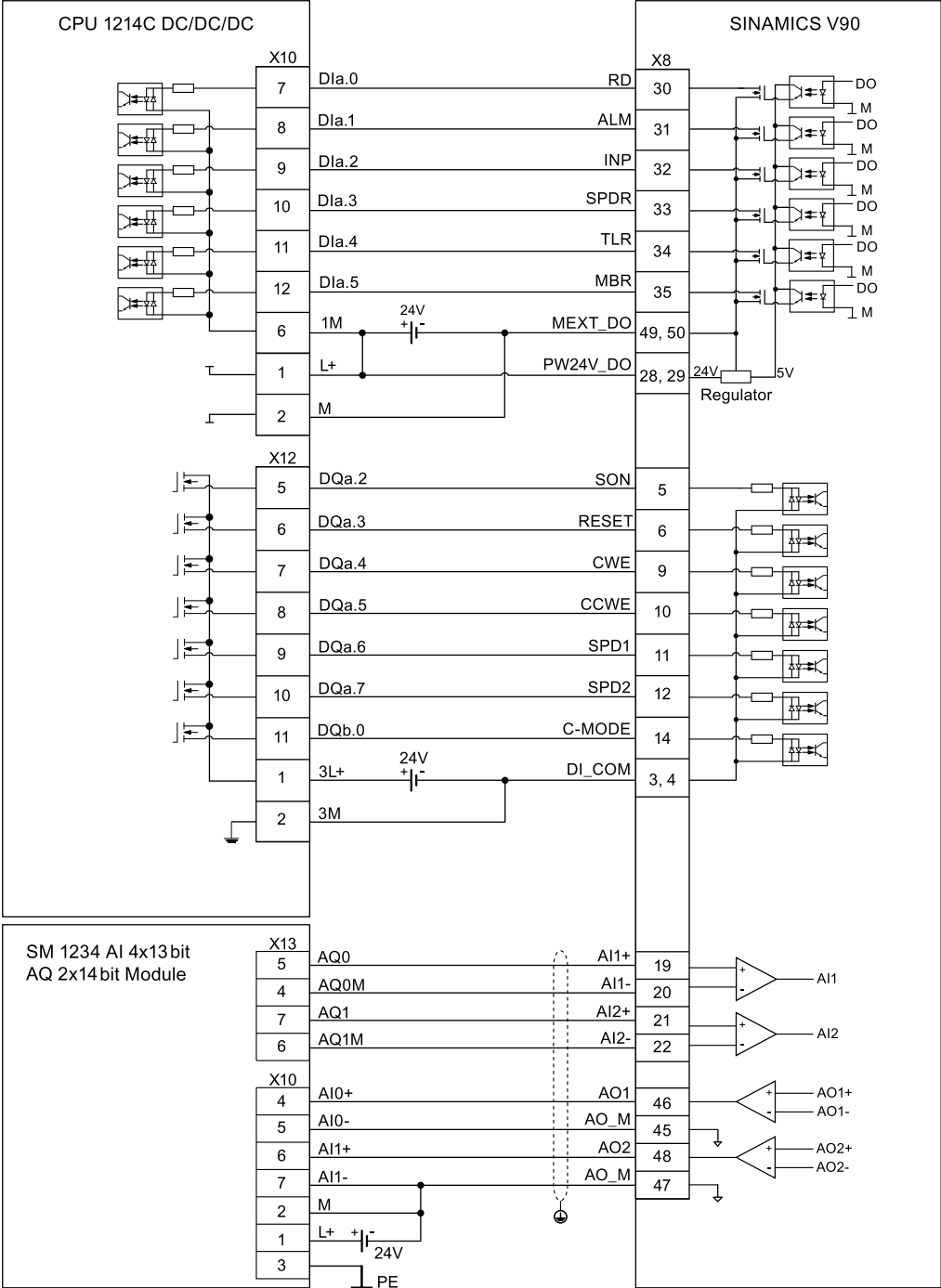

Ⓢ Shielded cable

- Torque control (T)

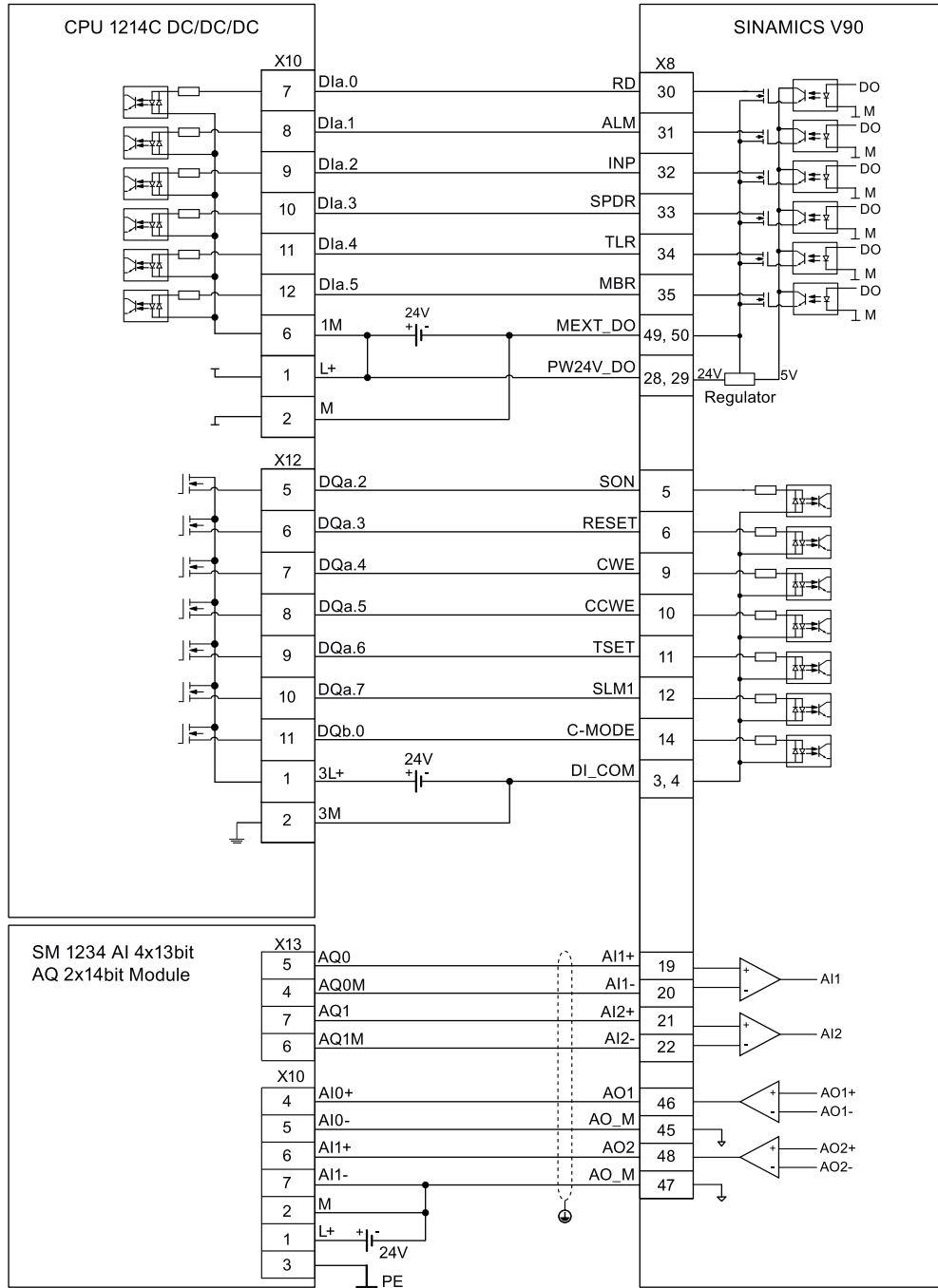

⊕ Shielded cable

4.4 24V power supply/STO - X6

The pin assignment for the X6 interface is shown as follows:

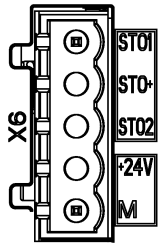
| Interface | Signal name | Description | Remarks |
|---|--|----------------------------------|---|
|  | STO 1 | Safe torque off channel 1 | - |
| | STO + | Power supply for safe torque off | - |
| | STO 2 | Safe torque off channel 2 | - |
| | +24 V | Power supply, 24 VDC | Voltage tolerance: <ul style="list-style-type: none"> • Without brake: -15% to +20% • With brake: -10% to +10% Maximum current consumption: <ul style="list-style-type: none"> • 1.6 A without brake power supply • 3.6 A with brake power supply |
| | M | Power supply, 0 VDC | |
| | Maximum conductor cross-section: 1.5 mm ² | | |

Wiring

WARNING

Material damages and personal injuries by the drop of a vertical axis

When the servo system is used as a vertical axis, the axis will drop if the positive and negative poles of the 24 V power supply are connected inversely. Unexpected drop of the vertical axis may cause material damages and personal injuries.

Make sure that the 24 V power supply is correctly connected.

WARNING

Material damages and personal injuries by the drop of a hanging axis

It is not allowed to use the STO with a hanging axis because the axis may drop. Unexpected drop of the hanging axis may cause material damages and personal injuries.

Note

Using the STO function

The STO1, STO+ and STO2 are short connected at the factory setting.

When the STO function is to be used, you must remove the short-circuit stick before connecting the STO interfaces. If you do not need to use it any more, you must reinsert the short-circuit stick; otherwise, the motor will not run.

For detailed information about the STO function, refer to "Safety Integrated basic functions (Page 193)".

4.5 Encoder interface - X9

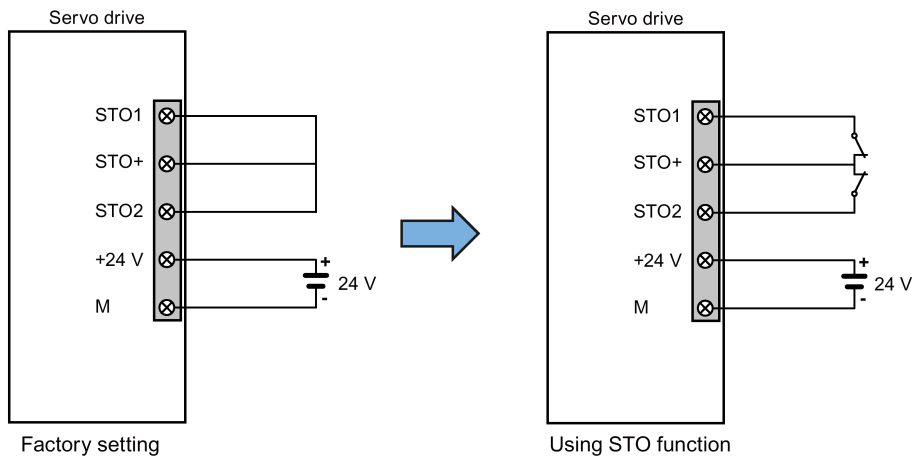

Plugging the 24 V power supply and STO cables

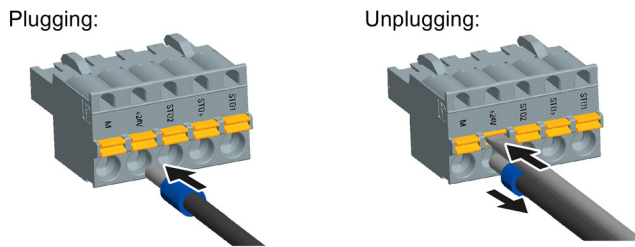

4.5 Encoder interface - X9

The SINAMICS V90 servo drive supports two kinds of encoders:

- Incremental encoder
- Absolute encoder

| |
|---|
| NOTICE |
| Cable shielding |
| The encoder cable must be shielded to meet the EMC requirements. |

Encoder interface - drive side

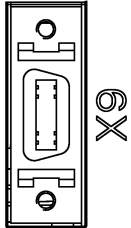
| Illustration | Pin | Signal name | Description |
|---|-----|-------------|---|
|  | 1 | Biss_DataP | Absolute encoder data signal, positive |
| | 2 | Biss_DataN | Absolute encoder data signal, negative |
| | 3 | Biss_ClockN | Absolute encoder clock signal, negative |
| | 4 | Biss_ClockP | Absolute encoder clock signal, positive |
| | 5 | P5V | Encoder power supply, +5V |
| | 6 | P5V | Encoder power supply, +5V |
| | 7 | M | Encoder power supply, grounding |
| | 8 | M | Encoder power supply, grounding |
| | 9 | Rp | Encoder R phase positive signal |
| | 10 | Rn | Encoder R phase negative signal |
| | 11 | Bn | Encoder B phase negative signal |
| | 12 | Bp | Encoder B phase positive signal |
| | 13 | An | Encoder A phase negative signal |
| | 14 | Ap | Encoder A phase positive signal |
| Screw type: UNC 4-40 (plug-in terminal block) | | | |
| Tightening torque: 0.5 - 0.6 Nm | | | |

Encoder connector - motor side

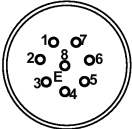
| Illustration | Pin No. | Incremental encoder | | Absolute encoder | |
|---|---------|---------------------|------------------|------------------|------------------|
| | | Signal | Description | Signal | Description |
|  | 1 | P_Supply | Power supply 5 V | P_Supply | Power supply 5 V |
| | 2 | M | Power supply 0 V | M | Power supply 0 V |
| | 3 | A+ | Phase A+ | n. c. | Not connected |
| | 4 | A- | Phase A- | Clock_N | Inverted clock |
| | 5 | B+ | Phase B+ | Data_P | Data |
| | 6 | B- | Phase B- | Clock_P | Clock |
| | 7 | R+ | Phase R+ | n. c. | Not connected |
| | 8 | R- | Phase R- | Data_N | Inverted data |

Wiring

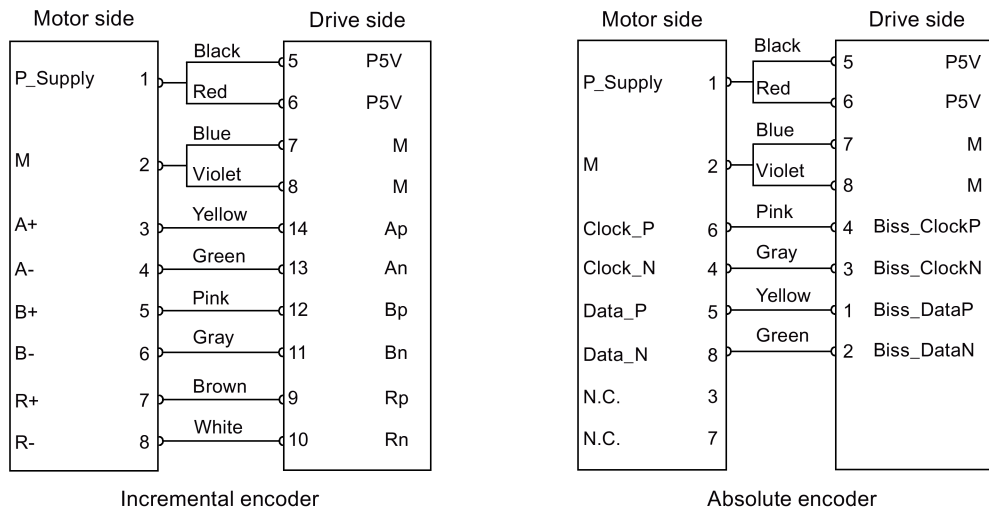

Grounding

To ensure better EMC effects, you are recommended to strip the encoder cable and connect the cable shield to earth, as shown in the following figure:

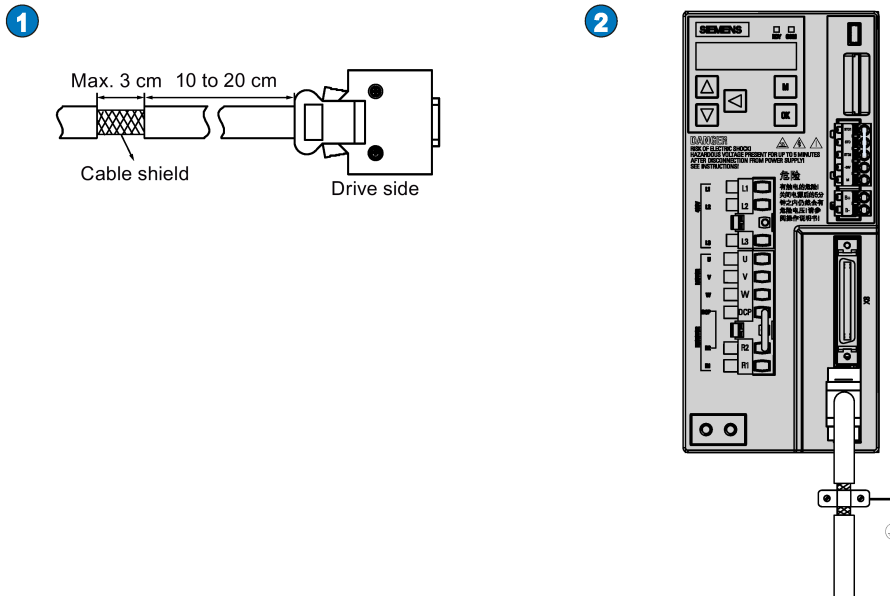

4.6 External braking resistor - DCP, R1

The SINAMICS V90 has been designed with an internal braking resistor to absorb regenerative energy from the motor. When the internal braking resistor cannot meet the braking requirements (e.g. the alarm A52901 is generated), you can connect an external braking resistor. For the selection of braking resistors, refer to Accessories (Page 31).

Connecting an external braking resistor

| |
|--|
|  WARNING |
| Damage to the drive |
| Before connecting an external resistor to DCP and R1, remove the short-circuit stick on the connectors. Otherwise, the drive may be damaged. |

For the connection of the external braking resistor, refer to System connection (Page 55).

4.7 Motor holding brake - X7

You can connect the SINAMICS V90 servo drive to a servo motor with brake to use the function of motor holding brake.

The relevant information about the interface and wiring is described as follows.

Note

Motor holding brake

For detailed information about the function of motor holding brake, refer to the section "Motor holding brake (Page 131)".

Motor holding brake - drive side

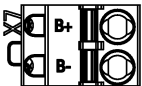
| Illustration | Signal | Description |
|---|--------|--------------------------------------|
|  | B+ | + 24 V, motor brake voltage positive |
| | B- | 0 V, motor brake voltage negative |
| Maximum conductor cross-section: 1.5 mm ² Input voltage tolerance: 24 V ± 10% | | |

Motor holding brake - motor side

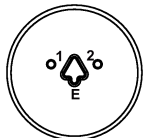
| Illustration | Pin No. | Signal | Description |
|---|---------|--------|--------------|
|  | 1 | Brake+ | Phase Brake+ |
| | 2 | Brake- | Phase Brake- |

Wiring

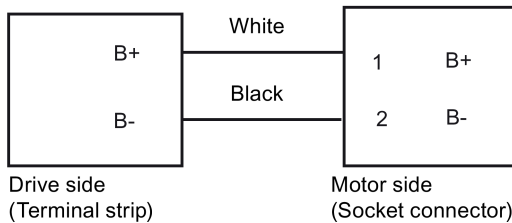

4.8 RS485 interface - X12

The SINAMICS V90 servo drives support communication with the PLCs through the RS485 interface (X12) over the USS protocol.

Pin assignment

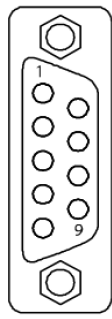
| Illustration | Pin | Signal name | Description |
|---|-----|-------------|--|
|  | 1 | Reserved | Do not use |
| | 2 | Reserved | Do not use |
| | 3 | 1RS_DP | RS485 differential signal |
| | 4 | Reserved | Do not use |
| | 5 | M | Ground to internal 3.3 V |
| | 6 | 3.3 V | 3.3 V power supply for internal signal |
| | 7 | Reserved | Do not use |
| | 8 | 1XRS_DP | RS485 differential signal |
| | 9 | Reserved | Do not use |

Type: 9-pin, Sub-D, female

Prior to commissioning, read "Basic operator panel (BOP) (Page 109)" for more information about the BOP operations. In case of any faults or alarms during commissioning, refer to Chapter "Diagnostics (Page 251)" for detailed description.

CAUTION

Carefully read the safety instructions

Before your commissioning or operation, read Section "General safety instructions (Page 11)" and the safety instructions on "**Commissioning/Operation**" in Section "Additional safety instructions (Page 16)" carefully. Failure to observe the instructions may cause serious effects.

WARNING

Material damages and personal injuries by the drop of a hanging axis

When the servo system is used as a hanging axis, the axis will drop if the positive and negative poles of the 24 V power supply are connected inversely. Unexpected drop of the hanging axis may cause material damages and personal injuries.

Before commissioning, a crosstie must be used to hold the hanging axis in prevention of an unexpected drop. In addition, make sure that the 24 V power supply is correctly connected.

NOTICE

Plugging or unplugging the SD card will cause startup failure.

Do not plug or unplug the SD card during startup; otherwise, the drive will fail to start up.

NOTICE

Existing setting data may be overwritten by the setting data on the SD card during startup.

- When a drive is switched on with an SD card containing user setting data, the existing setting data on the drive will be overwritten.
- When a drive is switched on with an SD card containing no user setting data, the drive will automatically save the existing user setting data onto the SD card.

Before starting up the drive with an SD card, check whether the SD card contains user setting data. Otherwise, the existing data on the drive may be overwritten.

Engineering tool - SINAMICS V-ASSISTANT

You can use the engineering tool SINAMICS V-ASSISTANT to perform the trial operation.

SINAMICS V-ASSISTANT is a software tool that can be installed on a PC and runs on the Windows operating system. It communicates with the SINAMICS V90 servo drive with a USB

5.1 Initial commissioning in JOG mode

cable. With SINAMICS V-ASSISTANT, you can change drive parameters and monitor drive working states in online mode.

For more information, refer to SINAMICS V-ASSISTANT Online Help. You can search and download SINAMICS V-ASSISTANT from Technical support website (<http://support.automation.siemens.com>).

5.1 Initial commissioning in JOG mode

Commissioning purpose

When the servo drive is powered on for the first time, you can perform a test run with the BOP or the engineering tool SINAMICS V-ASSISTANT to check:

- Whether the mains supply has been connected correctly
- Whether the 24 V power supply has been connected correctly
- Whether the cables (power cable, encoder cable, and brake cable) between the servo drive and the servo motor have been connected correctly
- Whether the motor speed and direction of rotation are correct.

Prerequisites

- The servo drive is connected to the servo motor without load.
- No PLC is connected to the drive system.

Operating sequence

Note

The digital signal EMGS **must** be kept at high level (1) to ensure normal operation.

| Step | Description | Remarks |
|------|---|--|
| 1 | Connect necessary units and check wiring. | <p>It is necessary to connect the following cables:</p> <ul style="list-style-type: none"> • Power cable • Encoder cable • Brake cable • Line supply cable • 24 VDC cable <p>Check:</p> <ul style="list-style-type: none"> • Is the device or cable damaged? • Do the connected cables have excessive pressure, load or tension? • Are the connected cables put on sharp edges? • Is the line supply within the permissible range? • Are all the terminals firmly and correctly connected? • Are all the connected system components well grounded? <p>Refer to "Connecting (Page 55)".</p> |
| 2 | Switch on the 24 V power supply. | |
| 3 | <p>Check the servo motor type.</p> <ul style="list-style-type: none"> • If the servo motor has an incremental encoder, input motor ID (p29000). • If the servo motor has an absolute encoder, the servo drive can identify the servo motor automatically. | <p>Fault F52984 occurs when the servo motor is not identified.</p> <p>You can find the motor ID from the motor rating plate. Go to "Motor components (Page 25)" for detailed descriptions about motor rating plate.</p> <p>Refer to "Basic operations (Page 115)" for information about how to change a parameter with the BOP.</p> |
| 4 | <p>Check the direction of motor rotation.</p> <p>The default direction of rotation is CW (clockwise). You can change it by setting the parameter p29001 if necessary.</p> | <p>p29001=0: CW</p> <p>p29001=1: CCW</p> |
| 5 | <p>Check the Jog speed.</p> <p>The default Jog speed is 100 rpm. You can change it by setting the parameter p1058.</p> | |
| 6 | Save parameters. | For detailed information about the parameter setting / saving with the BOP, refer to the sections "Basic operations (Page 115)" or "Saving parameters (RAM to ROM) (Page 121)". |
| 7 | Clear faults and alarms. | Refer to "Diagnostics (Page 251)". |
| 8 | <p>For the BOP, enter the Jog menu function and press the UP or DOWN button to run the servo motor.</p> <p>For the engineering tool, use the Jog function to run the servo motor.</p> | <p>For detailed information about Jog with the BOP, refer to Section "Jog (Page 120)".</p> <p>For detailed information about Jog with SINAMICS V-ASSISTANT, refer to SINAMICS V-ASSISTANT Online Help.</p> |

Note

When you run the servo motor with an incremental encoder in JOG mode, the servo motor makes a short buzzing sound indicating that it is identifying the magnetic pole position of the rotor.

5.2 Commissioning in pulse train position control mode (PTI)

| Step | Description | Comment |
|------|---|--|
| 1 | Switch off the mains supply. | |
| 2 | Power off the servo drive and connect it to the controller (for example, SIMATIC S7-200 SMART) with the signal cable. | The digital signals CWL, CCWL and EMGS must be kept at high level (1) to ensure normal operation. Refer to "Standard application wirings (factory setting) (Page 73)" and "Connection examples with PLCs (Page 81)". |
| 3 | Power on the servo drive. | |
| 4 | Check current control mode by viewing value of the parameter p29003. Pulse train input position control mode (p29003=0) is the factory setting of SINAMICS V90 servo drives. | Refer to "Compound controls (Page 127)". |
| 5 | Configure necessary digital input signals by setting the following parameters: <ul style="list-style-type: none"> • p29301[0]: DI1 • p29302[0]: DI2 • p29303[0]: DI3 • p29304[0]: DI4 • p29305[0]: DI5 • p29306[0]: DI6 • p29307[0]: DI7 • p29308[0]: DI8 | The factory settings are: <ul style="list-style-type: none"> • p29301[0]: 1 (SON) • p29302[0]: 2 (RESET) • p29303[0]: 3 (CWL) • p29304[0]: 4 (CCWL) • p29305[0]: 5 (G-CHANGE) • p29306[0]: 6 (P-TRG) • p29307[0]: 7 (CLR) • p99308[0]: 10 (TLIM1) Refer to "Digital inputs/outputs (DIs/DOs) (Page 60)". |
| 6 | Select a pulse input channel by setting parameter p29014. | <ul style="list-style-type: none"> • p29014=0: high-speed 5 V differential pulse train input • p29014=1: 24 V single end pulse train input 24 V single end pulse train input is the factory setting. Refer to "Selecting a setpoint pulse train input channel (Page 135)". |

| Step | Description | Comment |
|------|---|--|
| 7 | Select a setpoint pulse train input form by setting parameter p29010. | <ul style="list-style-type: none"> p29010=0: pulse + direction, positive logic p29010=1: AB track, positive logic p29010=2: pulse + direction, negative logic p29010=3: AB track, negative logic <p>The factory setting is p29010=0 (pulse + direction, positive logic).</p> <p>Refer to "Selecting a setpoint pulse train input form (Page 135)".</p> |
| 8 | Calculate the electronic gear ratio, then input values into parameters p29011, p29012, and p29013. | <ul style="list-style-type: none"> p29011: number of setpoint pulses per revolution. p29012: numerator of the electronic gear. Four numerators in total (p29012[0] to p29012[3]) are available. p29013: denominator of the electronic gear. <p>Refer to "Electronic gear ratio (Page 137)".</p> |
| 9 | Check the encoder type. If it is an absolute encoder, adjust the absolute encoder with the BOP menu function "ABS". | Refer to "Adjusting an absolute encoder (Page 126)". |
| 10 | Clear faults and alarms. | Refer to "Diagnostics (Page 251)". |
| 11 | Trigger SON to the high level, input the setpoint pulse train from the command device, and then the servo motor starts running. | Use a low pulse frequency at first to check the direction and speed of rotation. |
| 12 | The system commissioning in pulse train input position control mode ends. | You can check the system performance. If it is not ok, you can adjust it. Refer to "Tuning (Page 197)". |

5.3 Commissioning in internal position control mode (IPos)

| Step | Description | Remarks |
|------|---|--|
| 1 | Switch off the mains supply. | |
| 2 | Power off the servo drive and connect it to the controller (for example, SIMATIC S7-200 SMART) with the signal cable. | The digital signals CWL, CCWL and EMGS must be kept at high level (1) to ensure normal operation. Refer to "Standard application wirings (factory setting) (Page 73)" and "Connection examples with PLCs (Page 81)". |
| 3 | Power on the servo drive. | |
| 4 | Switch to the internal position control mode by setting p29003=1. | Refer to "Compound controls (Page 127)". |
| 5 | Save the parameter and restart the servo drive to apply the settings of the internal position control mode. | |

| Step | Description | Remarks |
|------|--|--|
| 6 | Configure necessary digital input signals by setting the following parameters: <ul style="list-style-type: none"> • p29301[1]: DI1 • p29302[1]: DI2 • p29303[1]: DI3 • p29304[1]: DI4 • p29305[1]: DI5 • p29306[1]: DI6 • p29307[1]: DI7 • p29308[1]: DI8 | The factory settings are: <ul style="list-style-type: none"> • p29301[1]: 1 (SON) • p29302[1]: 2 (RESET) • p29303[1]: 3 (CWL) • p29304[1]: 4 (CCWL) • p29305[1]: 5 (G-CHANGE) • p29306[1]: 6 (P-TRG) • p29307[1]: 21 (POS1) • p29308[1]: 22 (POS2) Refer to "Digital inputs/outputs (DIs/DOs) (Page 60)". NOTE: If your encoder is an incremental encoder, you must configure the digital input signal REF or SREF according to your selection of referencing mode. Refer to "Referencing (Page 153)". |
| 7 | Configure the fixed position setpoint (p2617[0] to p2617[7]) according to mechanism. | <ul style="list-style-type: none"> • Fixed position setpoint 1: p2617[0] • Fixed position setpoint 2: p2617[1] • Fixed position setpoint 3: p2617[2] • Fixed position setpoint 4: p2617[3] • Fixed position setpoint 5: p2617[4] • Fixed position setpoint 6: p2617[5] • Fixed position setpoint 7: p2617[6] • Fixed position setpoint 8: p2617[7] Refer to "Setting fixed position setpoint (Page 149)". |
| 8 | Check and select a positioning mode by setting parameter p29241. | <ul style="list-style-type: none"> • p29241=0: incremental • p29241=1: absolute • p29241=2: absolute, positive (only for a rotary axis with modulo correction) • p29241=3: absolute, negative (only for a rotary axis with modulo correction) Refer to "Selecting a positioning mode - absolute/incremental (Page 151)". |
| 9 | Check the encoder type and perform referencing: <ul style="list-style-type: none"> • For an incremental encoder, choose a referencing mode by setting parameter p29240 and perform referencing. • For an absolute encoder, adjust the encoder with the BOP menu function "ABS". Refer to "Adjusting an absolute encoder (Page 126)". | Five referencing modes are available for the incremental encoder: <ul style="list-style-type: none"> • p29240=0: with digital input signal REF • p29240=1 (default): external referencing cam (REF) and encoder zero mark • p29240=2: only encoder zero mark • p29240=3: external referencing cam (CCWL) and encoder zero mark • p29240=4: external referencing cam (CWL) and encoder zero mark. Refer to "Referencing (Page 153)". |

| Step | Description | Remarks |
|------|--|---|
| 10 | Clear faults and alarms. | Refer to "Diagnostics (Page 251)". |
| 11 | Trigger the digital signal SON to be high level. | |
| 12 | Select a fixed position setpoint by configuring the digital inputs POS1, POS2 and POS3, then start positioning with the triggering signal P-TRG. | POS3 : POS2 : POS1 0 : 0 : 0: fixed position setpoint 1 (p2617[0]) 0 : 0 : 1: fixed position setpoint 2 (p2617[1]) 0 : 1 : 0: fixed position setpoint 3 (p2617[2]) 0 : 1 : 1: fixed position setpoint 4 (p2617[3]) 1 : 0 : 0: fixed position setpoint 5 (p2617[4]) 1 : 0 : 1: fixed position setpoint 6 (p2617[5]) 1 : 1 : 0: fixed position setpoint 7 (p2617[6]) 1 : 1 : 1: fixed position setpoint 8 (p2617[7]) Refer to "Selecting a fixed position setpoint and starting positioning (Page 162)". |
| 13 | The system commissioning in internal position control mode ends. | You can check the system performance. If it is not ok, you can adjust it. Refer to "Tuning (Page 197)". |

5.4 Commissioning in speed control mode (S)

| Step | Description | Remarks |
|------|---|---|
| 1 | Switch off the mains supply. | |
| 2 | Power off the servo drive and connect it to the controller (for example, SIMATIC S7-200 SMART) with the signal cable. | The digital signals CWL, CCWL and EMGS must be kept at high level (1) to ensure normal operation. Refer to "Standard application wirings (factory setting) (Page 73)" and "Connection examples with PLCs (Page 81)". |
| 3 | Power on the servo drive. | |
| 4 | Switch to the speed control mode by setting p29003=2. | Refer to "Compound controls (Page 127)". |
| 5 | Restart the servo drive to apply the settings of the speed control mode. | |
| 6 | Configure necessary digital input signals by setting the following parameters: <ul style="list-style-type: none"> • p29301[2]: DI1 • p29302[2]: DI2 • p29303[2]: DI3 • p29304[2]: DI4 • p29305[2]: DI5 • p29306[2]: DI6 • p29307[2]: DI7 • p29308[2]: DI8 | The factory settings are: <ul style="list-style-type: none"> • p29301[2]: 1 (SON) • p29302[2]: 2 (RESET) • p29303[2]: 3 (CWL) • p29304[2]: 4 (CCWL) • p29305[2]: 12 (CWE) • p29306[2]: 13 (CCWE) • p29307[2]: 15 (SPD1) • p29308[2]: 16 (SPD2) Refer to "Digital inputs/outputs (DIs/DOs) (Page 60)". |

5.5 Commissioning in torque control mode (T)

| Step | Description | Remarks |
|------|---|---|
| 7 | Configure speed setpoint. | You can select the external analog speed setpoint or one of seven fixed speed setpoints by configuring the digital signals SPD3, SPD2 and SPD1. SPD3 : SPD2 : SPD1 0 : 0 : 0: external analog speed setpoint (analog input 1) 0 : 0 : 1: fixed speed setpoint 1 (p1001) 0 : 1 : 0: fixed speed setpoint 2 (p1002) 0 : 1 : 1: fixed speed setpoint 3 (p1003) 1 : 0 : 0: fixed speed setpoint 4 (p1004) 1 : 0 : 1: fixed speed setpoint 5 (p1005) 1 : 1 : 0: fixed speed setpoint 6 (p1006) 1 : 1 : 1: fixed speed setpoint 7 (p1007) Refer to "Configuring speed setpoint (Page 164)". |
| 8 | If the external analog speed setpoint is used, configure the maximum analog speed setpoint corresponding to 10 V by setting parameter p29060. | |
| 9 | Clear faults and alarms. | Refer to "Diagnostics (Page 251)". |
| 10 | Change SON status to be high level (1) and the servo motor starts running according to configured speed setpoint. | The actual speed of the servo motor can be viewed from the BOP operating display. The default display is the actual speed. Refer to "Actual status display (Page 114)". |
| 11 | The system commissioning in speed control mode ends. | You can check the system performance. If it is not ok, you can adjust it. Refer to "Tuning (Page 197)". |

5.5 Commissioning in torque control mode (T)

| Step | Description | Remarks |
|------|---|--|
| 1 | Switch off the mains supply. | |
| 2 | Power off the servo drive and connect it to the controller (for example, SIMATIC S7-200 SMART) with the signal cable. | The digital signals CWL, CCWL and EMGS must be kept at high level (1) to ensure normal operation. Refer to "Standard application wirings (factory setting) (Page 73)" and "Connection examples with PLCs (Page 81)". |
| 3 | Power on the servo drive. | |
| 4 | Switch to the torque control mode by setting p29003=3. | Refer to "Compound controls (Page 127)". |
| 5 | Restart the servo drive to apply the settings of the torque control mode. | |

| Step | Description | Remarks |
|------|---|--|
| 6 | Configure necessary digital input signals by setting the following parameters: <ul style="list-style-type: none"> • p29301[3]: DI1 • p29302[3]: DI2 • p29303[3]: DI3 • p29304[3]: DI4 • p29305[3]: DI5 • p29306[3]: DI6 • p29307[3]: DI7 • p29308[3]: DI8 | The factory settings are: <ul style="list-style-type: none"> • p29301[3]: 1 (SON) • p29302[3]: 2 (RESET) • p29303[3]: 3 (CWL) • p29304[3]: 4 (CCWL) • p29305[3]: 12 (CWE) • p29306[3]: 13 (CCWE) • p29307[3]: 18 (TSET) • p29308[3]: 19 (SLIM1) Refer to "Digital inputs/outputs (DIs/DOs) (Page 60)". |
| 7 | Select torque setpoint by configuring the digital input signal TSET. | <ul style="list-style-type: none"> • TSET = low level (0): external analog torque setpoint (analog input 2) • TSET = high level (1): fixed torque setpoint |
| 8 | If the external analog torque setpoint is used, configure the scaling (percentage of the rated torque) for analog torque setpoint corresponding to 10 V by setting parameter p29041[0]. | Refer to "Torque control with external analog torque setpoint (Page 171)". |
| 9 | If the fixed torque setpoint is used, input your desired torque setpoint value into parameter p29043. | Refer to "Torque control with fixed torque setpoint (Page 172)". |
| 10 | Clear faults and alarms. | Refer to "Diagnostics (Page 251)". |
| 11 | Change SON status to be high level (1) and the servo motor starts running according to configured torque setpoint. | The actual torque of the servo motor can be viewed from the BOP operating display. The default display is actual speed. You can change it by setting p29002=2. Refer to "Actual status display (Page 114)". |
| 12 | The system commissioning in torque control mode ends. | You can check the system performance. If it is not ok, you can adjust it. Refer to "Tuning (Page 197)". |

Basic operator panel (BOP)

6.1 BOP overview

The SINAMICS V90 servo drive is designed with a Basic Operator Panel (BOP) on the front panel of the servo drive:

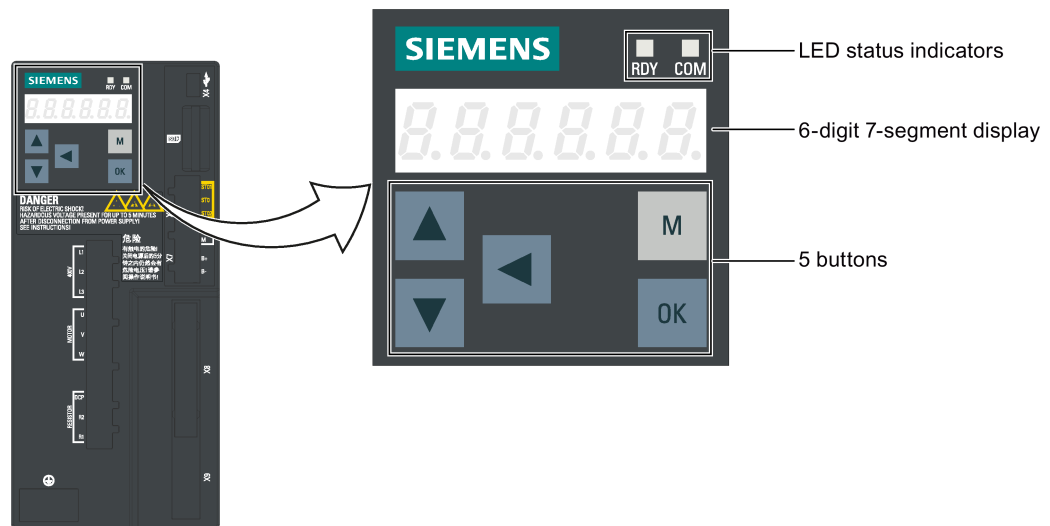

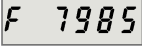

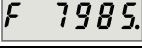

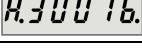

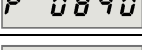

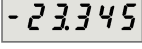



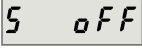

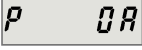

Figure 6-1 BOP overview

You can use the BOP for the following operations:











- Standalone commissioning
- Diagnosis
- Parameter access
- Parameter settings
- SD card operations
- Drive restart

6.1.1 BOP display

| Display | Example | Description | Remarks |
|--------------|---|---|--|
| 8.8.8.8.8.8. |  | Drive is in startup state | |
| ----- |  | Drive is busy | |
| Fxxxxx |  | Fault code | In the case of a single fault |
| F.xxxxx. |  | Fault code of the first fault | In the case of multiple faults |
| Fxxxxx. |  | Fault code | In the case of multiple faults |
| Axxxxx |  | Alarm code | In the case of a single alarm |
| A.xxxxx. |  | Alarm code of the first alarm | In the case of multiple alarms |
| Axxxxx. |  | Alarm code | In the case of multiple alarms |
| Rxxxxx |  | Parameter number | Read-only parameter |
| Pxxxxx |  | Parameter number | Editable parameter |
| P.xxxxx |  | Parameter number | Editable parameter; the dot means that at least one parameter has been changed |
| In xx |  | Indexed parameter | Figure after "In" indicates the number of indices. For example, "In 01" means that this indexed parameter is 1. |
| xxx.xxx |  | Negative parameter value | |
| xxx.xx<> |  | Current display can be moved to left or right | |
| xxxx.xx> |  | Current display can be moved to right | |
| xxxx.xx< |  | Current display can be moved to left | |
| S Off |  | Operating display: servo off | |
| Para |  | Editable parameter group | Refer to the section "Change a parameter value (Page 116)". |
| P 0x |  | Parameter group | Six groups are available: 1. P0A : basic 2. P0B : gain adjustment 3. P0C : speed control 4. P0D : torque control 5. P0E : position control 6. P0F : IO |

| Display | Example | Description | Remarks |
|---------|---------|---|---|
| Data | | Read-only parameter group | Refer to "Read a parameter value (Page 118)". |
| Func | | Function group | Refer to "Function overview (Page 119)". |
| Jog | | Jog function | Refer to "Jog (Page 120)". |
| Save | | Save data in drive | Refer to "Save parameters in the servo drive (Page 121)". |
| defu | | Restore drive to default settings | Refer to "Reset parameters to default values (Page 122)". |
| dr--sd | | Save data from drive to SD card | Refer to "Copy parameters from the servo drive to an SD card (Page 122)". |
| sd--dr | | Upload data from SD card to drive | Refer to "Copy parameters from an SD card to the servo drive (Page 123)". |
| Update | | Update firmware | Refer to "Update firmware (Page 124)". |
| A OFF1 | | Adjust AI1 offset | Refer to "Adjust AI offset (Page 124)". |
| A OFF2 | | Adjust AI2 offset | Refer to "Adjust AI offset (Page 124)". |
| ABS | | The zero position has not been set | Refer to "Set zero position (Page 126)". |
| A.B.S. | | The zero position has been set | Refer to "Set zero position (Page 126)". |
| r xxx | | Actual speed (positive direction) | |
| r -xxx | | Actual speed (negative direction) | |
| T x.x | | Actual torque (positive direction) | |
| T -x.x | | Actual torque (negative direction) | |
| DCxxx.x | | Actual DC link voltage | |
| Exxxx | | Position following error | |
| Con | | The communication between the SINAMICS V-ASSISTANT and the servo drive is established. In this case, the BOP is protected from any operations except clearing alarms and acknowledging faults. | |

6.1.2 Control buttons

| Button | Description | Functions |
|---|--|--|
|  | M button | <ul style="list-style-type: none"> Exits from the current menu Switches between operating modes in the top level menu |
|  | OK button | <p>Short-pressing:</p> <ul style="list-style-type: none"> Confirms selection or input Enters sub menu Acknowledges faults <p>Long-pressing: Activates auxiliary functions</p> <ul style="list-style-type: none"> Sets Drive Bus address Jog Saves parameter set in drive (RAM to ROM) Sets parameter set to default Transfers data (drive to SD card) Transfers data (SD card to drive) Updates firmware |
|  | UP button | <ul style="list-style-type: none"> Navigates to the next item Increases a value JOG in CW (clockwise) |
|  | DOWN button | <ul style="list-style-type: none"> Navigates to the previous item Decreases a value JOG in CCW (counter-clockwise) |
|  | SHIFT button | <p>Moves the cursor from digit to digit for single digit editing, including the digit of positive/negative sign</p> <p>Note: When the sign is edited, "_" indicates positive and "-" indicates negative.</p> |
|  | Press the key combination for four seconds to restart the drive | |
|  | Moves current display to the left page when  is displayed at the upper right corner, for example <i>00.000r</i> . | |
|  | Moves current display to the right page when  is displayed at the lower right corner, for example <i>00 10l</i> . | |

6.2 Parameter structure

The overall parameter structure of SINAMICS V90 BOP is designed as follows:

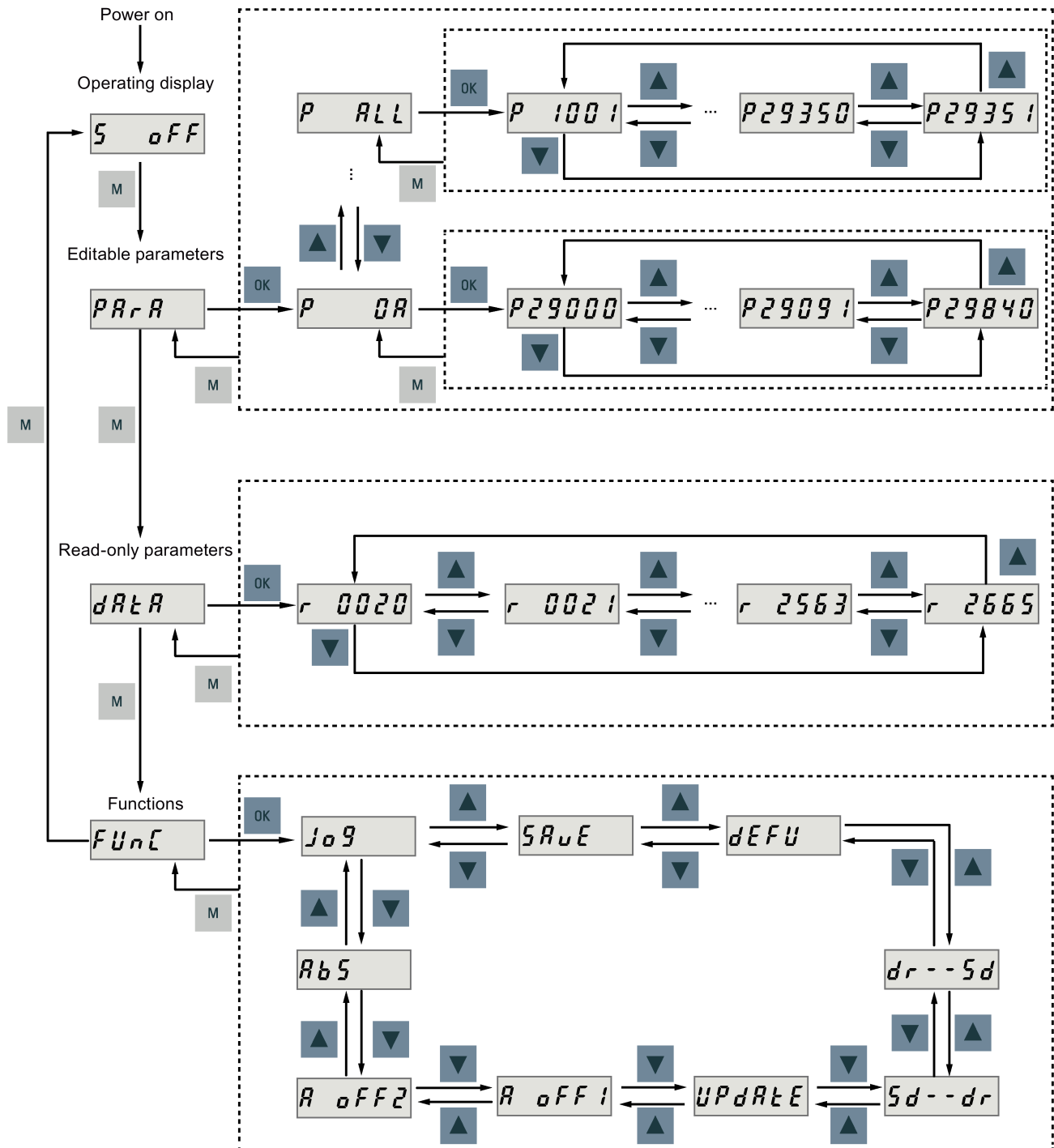

Note

There is no ABS menu function for a servo motor with an incremental encoder.

The ABS menu function is **only** available for a servo motor with an absolute encoder

6.3 Actual status display

The following drive states can be monitored using the operating panel after power-on:

- Servo off
- Actual speed
- Actual torque
- DC voltage
- Actual position
- Position offset

If servo enable signal is available, actual drive speed is displayed by default; otherwise, "**S OFF**" (servo off) is displayed.

With p29002, you define which of the following drive operating status data is to be displayed on the BOP.:

| Parameter | Value | Meaning |
|-----------|-------------|-----------------|
| p29002 | 0 (default) | Actual speed |
| | 1 | DC voltage |
| | 2 | Actual torque |
| | 3 | Actual position |
| | 4 | Position offset |

Note

Make sure you save p29002 after modification.

6.4 Basic operations

Overview

- Editable parameters: all **P** parameters under the "**Para**" menu are settable parameters. Seven groups in total are available:
 - **P0A**: basic
 - **P0B**: gain adjustment
 - **P0C**: speed control
 - **P0D**: torque control
 - **P0E**: position control
 - **P0F**: IO
 - **P All**: all parameters
- Read-only parameters: All **r** parameters under the "**Data**" menu are read-only parameters. You can only read values of these parameters.

Parameters with index

Some parameters have several indices. Each index has its own meaning and corresponding value.

Parameters without index

All parameters that do not have indices are parameters without index.

6.4.1 Editing parameters

You can edit a parameter value in two methods:

- Method 1: change the value directly with the **UP** or **DOWN** button
- Method 2: move the cursor to a digit with the **SHIFT** button, then change the digit value with the **UP** or **DOWN** button

If you edit a parameter value with Method 1, proceed as follows:

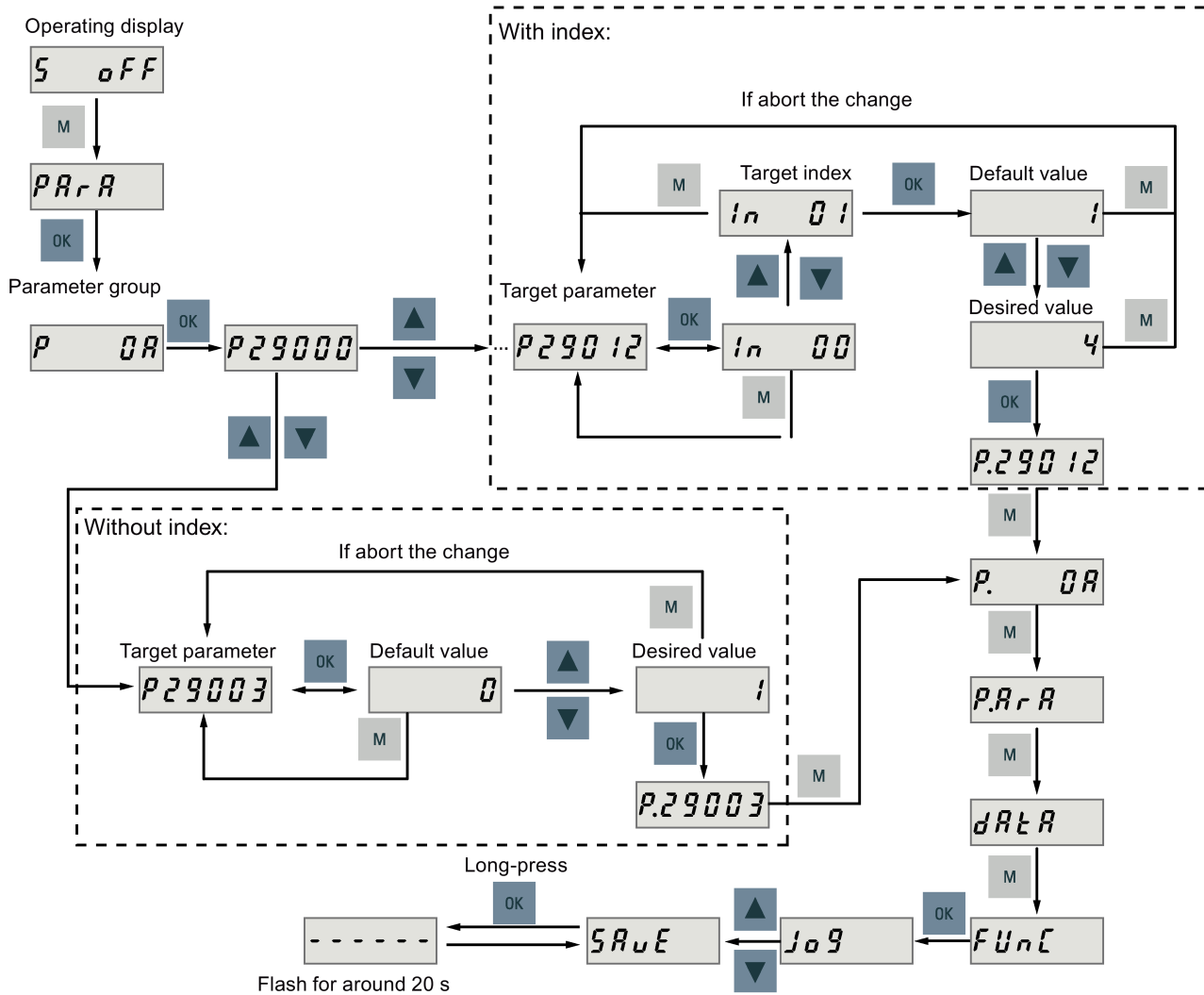

To edit a parameter value with Method 2, proceed as follows:

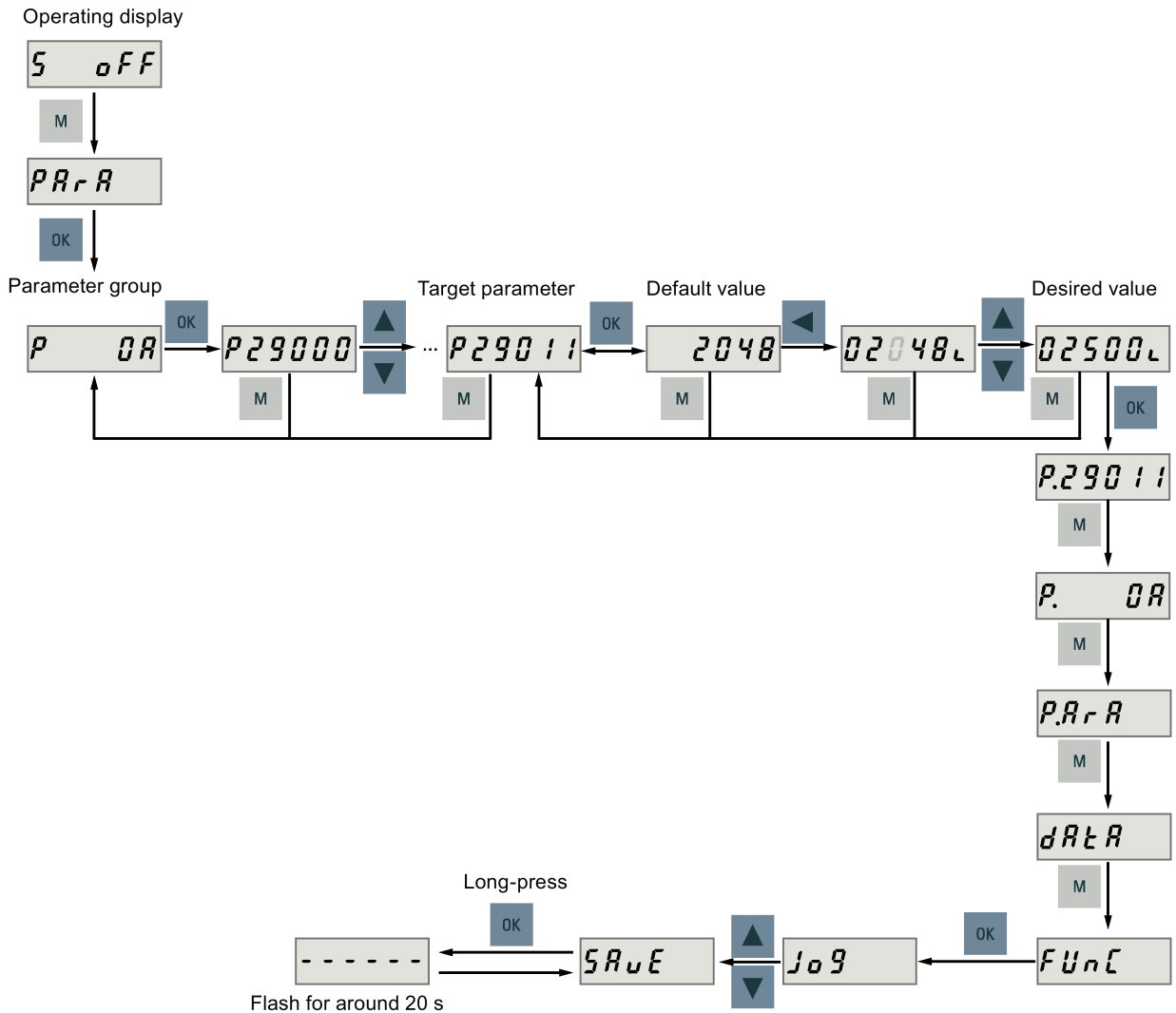

NOTICE

It is forbidden to use this function when the servo is ON.

Use this function when the servo is OFF.

Note

The parameters p1414 and p1656 cannot be changed using the **SHIFT** button.

6.4.2 Viewing parameters

To view a parameter, proceed as follows:

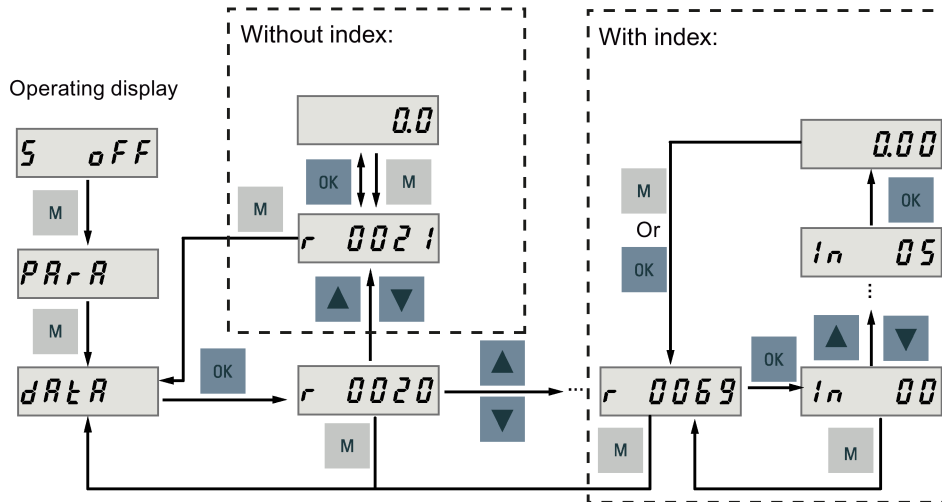

6.4.3 Searching parameters in "P ALL" menu

If you do not know which group that a parameter belongs to, you can find it in the "P ALL" menu.

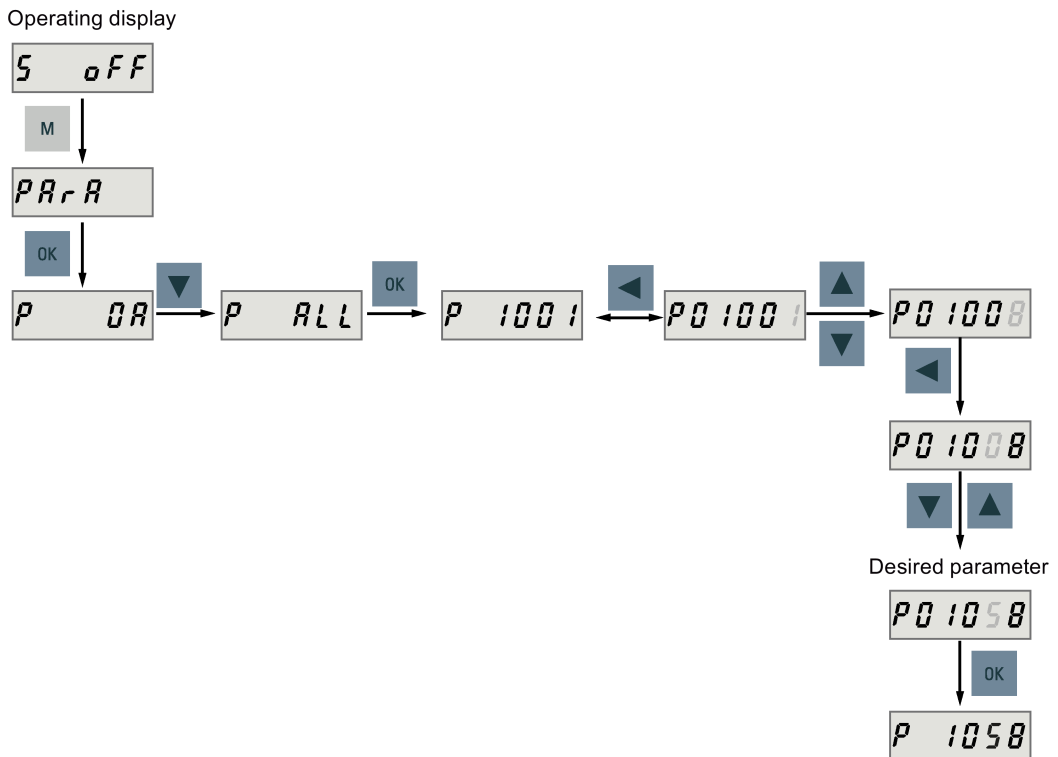

Note**Invalid parameter number**

If the input parameter number is unavailable, the nearest parameter number to the input value is displayed.

6.5 Auxiliary functions

In total, there are 9 BOP functions available:

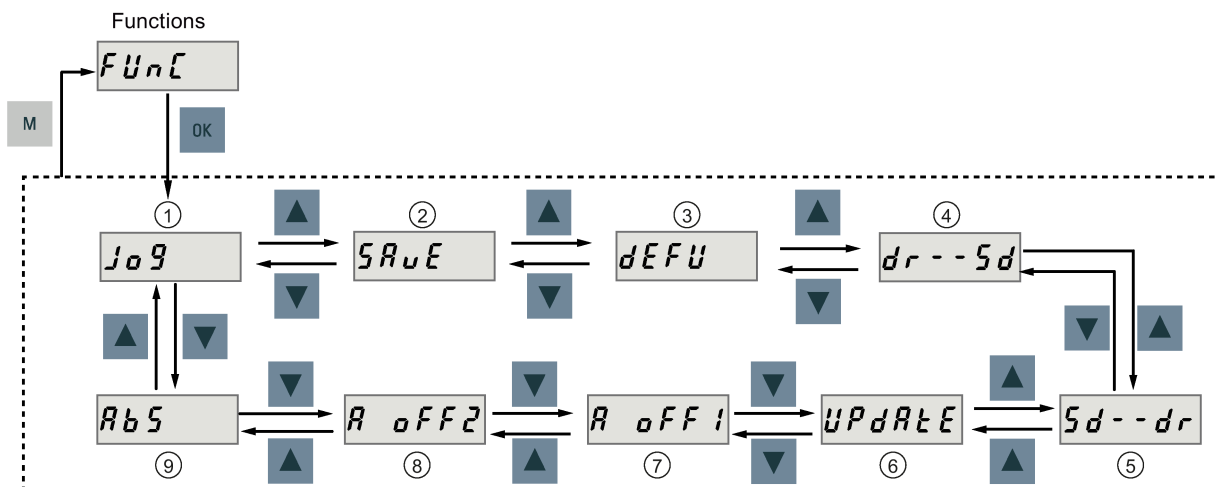

Figure 6-2 Overview of SINAMICS V90 BOP functions

- | | |
|---|---------------------------|
| ① Jog | ⑥ Update firmware |
| ② Save parameter set in drive | ⑦ Adjust AI1 offset |
| ③ Restore parameter values to default | ⑧ Adjust AI2 offset |
| ④ Copy parameter set from drive to an SD card | ⑨ Adjust absolute encoder |
| ⑤ Copy parameter set from an SD card to drive | |

NOTE:

This function is available only when the servo motor with an absolute encoder is connected.

6.5.1 Jog

Note

The digital signal EMGS **must** be kept at high level (1) to ensure normal operation.
The travel limit signals (CWL/CCWL) are disabled during Jog operation with the BOP.

With the Jog function, you can run the connected motor and view Jog speed or Jog torque.
To run the connected motor with the Jog function and view the Jog speed, proceed as follows:

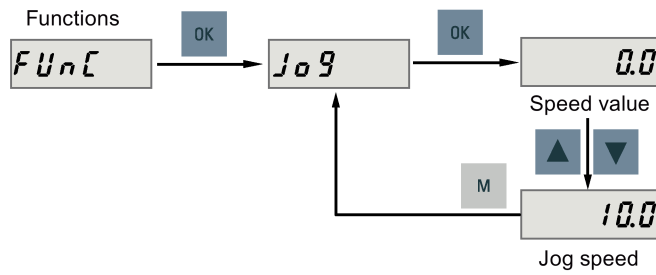

Figure 6-3 Jog in speed (example)

To run the connected motor with the Jog function and view the Jog torque, proceed as follows:

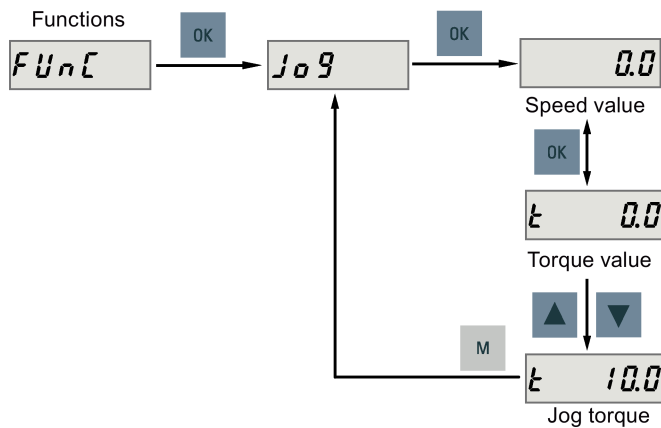

Figure 6-4 Jog in torque (example)

NOTICE

Exit the Jog mode after completing Jog run.

The servo motor cannot run if the servo drive is in the Jog mode.

6.5.2 Saving parameters (RAM to ROM)

This function is used for saving a parameter set from the drive RAM to drive ROM.

To use this function, proceed as follows:

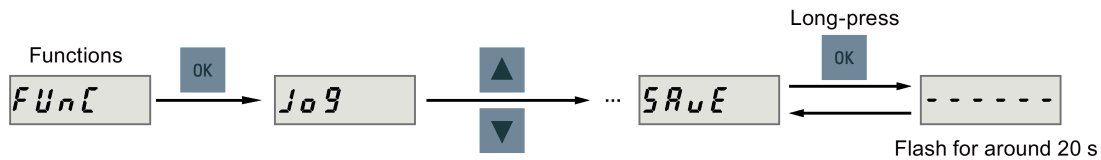

NOTICE

Plugging or unplugging the SD card will cause saving failure.

Do not plug or unplug the SD card during saving; otherwise, the saving operation will fail.

Note

- If an SD card has been inserted, the parameter set will be saved onto the SD card simultaneously.
- All signal functions become inactive during the saving process. Use the signal functions afterwards.

Reference

Editing parameters (Page 116)

6.5.3 Setting parameters to default

This function is used to reset all parameters to their default values.

To reset the parameters to their default values, proceed as follows:

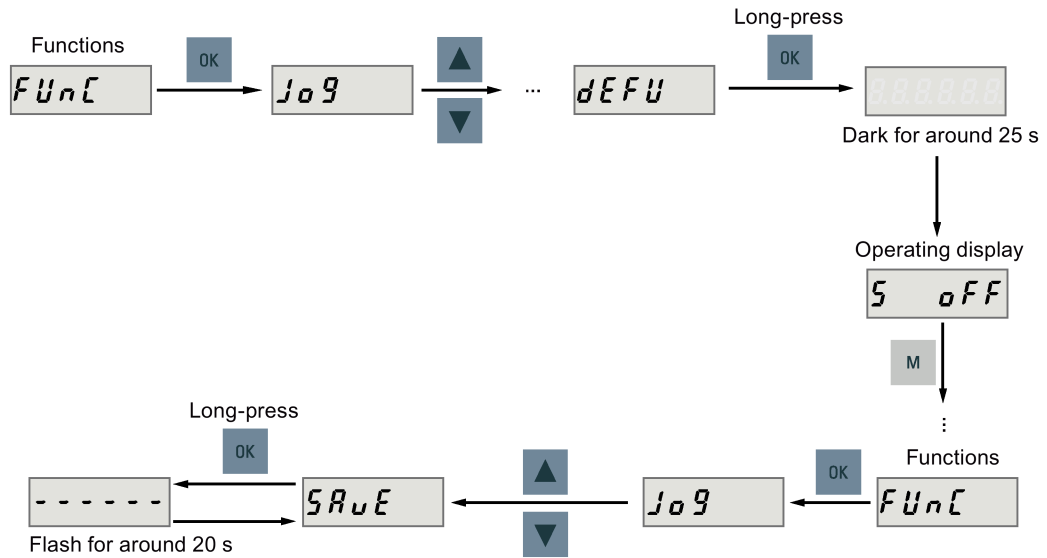

Note

You **must** save the parameter set after setting the parameter set to the default values; otherwise, the default values will not be activated.

Reference

Saving parameters (RAM to ROM) (Page 121)

6.5.4 Transferring data (drive to SD)

You can save the parameter set to an SD card with the BOP. To do this, proceed as follows:

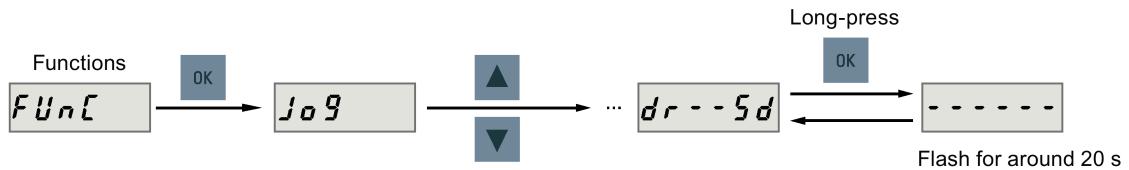

NOTICE

It is forbidden to use this function when the servo is ON.

Use this function when the servo is OFF.

NOTICE

Plugging or unplugging the SD card will cause copying failure.

Do not plug or unplug the SD card during copying; otherwise, the copying operation will fail.

Note

Write protection function is not supported by SINAMICS V90. Data in the SD card will be overwritten even if the write protection function of the SD card is enabled.

6.5.5 Transferring data (SD to drive)

You can also upload the parameters from an SD card to the servo drive. To do this, proceed as follows:

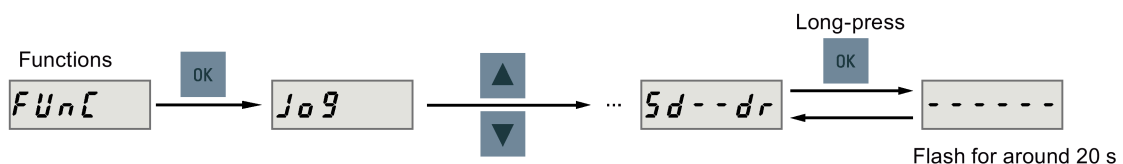
**NOTICE**

It is forbidden to use this function when the servo is ON.

Use this function when the servo is OFF.

NOTICE

Plugging or unplugging the SD card will cause copying failure.

Do not plug or unplug the SD card during copying; otherwise, the copying operation will fail.

Note**Parameter inconsistency**

If the parameters on the SD card are inconsistent with existing parameters in the drive memory, you **must** restart the servo drive to apply the changes.

6.5.6 Updating firmware

With the firmware update function of the BOP, you can update the drive firmware. To do this, you have to store proper firmware files on an SD card and insert it into the SD card slot. After that, proceed as follows:

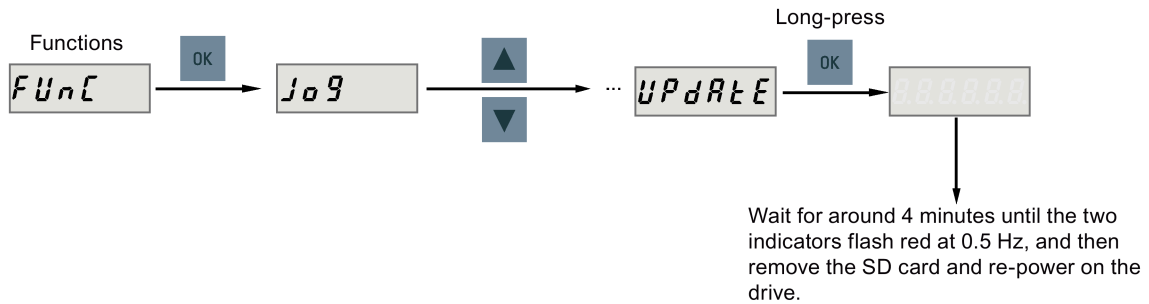

| |
|---|
| ⚠ CAUTION |
| Improper firmware files will cause update failure. |
| When the update fails, the RDY indicator flashes red at 2 Hz and the COM indicator becomes red on. An update failure is probably caused by improper firmware files or files missing. |
| <ul style="list-style-type: none">• If the firmware files on the SD card are corrupt, the servo drive cannot start up after power-on.• If the firmware on the SD card is the same with the current firmware of the servo drive, only a restart is performed. |
| When a failure occurs, try to update the firmware again using proper firmware files. If the failure persists, contact your local distributor. |

Note

Update the firmware by restarting the drive.

After inserting the SD card with proper firmware files, you can also update the firmware by restarting the drive.

6.5.7 Adjusting AI offsets

| |
|--|
| NOTICE |
| Connect to ground |
| You must firstly connect the AI1 or AI2 to ground and then adjust AI offset. |
| Refer to section "Analog inputs (Page 70)". |

With the BOP function menu "A OFF1" or "A OFF2", AI offset can be adjusted automatically. Proceed as follows to adjust AI offset:

- Adjust AI1 offset

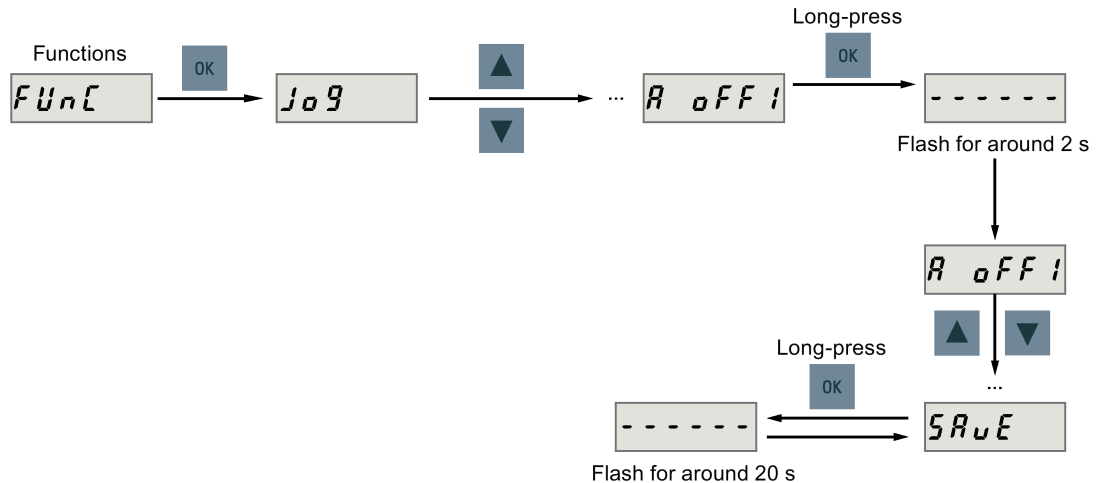

- Adjust AI2 offset

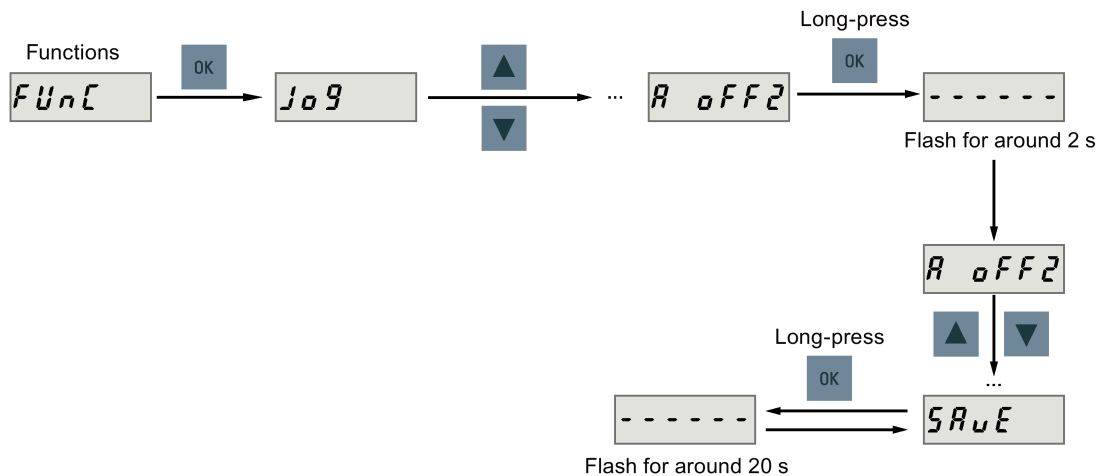

Note

Save parameter

Offset value is set into parameter p29042 (for AI1) or parameter p29061 (for AI2). You **must** perform parameter saving after the automatic adjustment of AI offset.

Parameter range

p29042 or p29061 ranges from -0.5 V to + 0.5 V. A value that is out of this range causes an alarm.

Refer to chapter "Parameter list (Page 219)".

6.5.8 Adjusting an absolute encoder

NOTICE

Motor type
This function is **only** available when you are using a servo motor with the absolute encoder.

Stop servo motor
You must stop servo motor before adjusting absolute encoder.

With the BOP function menu "**ABS**", you can set current position of absolute encoder to be zero position. To do this, proceed as follows:

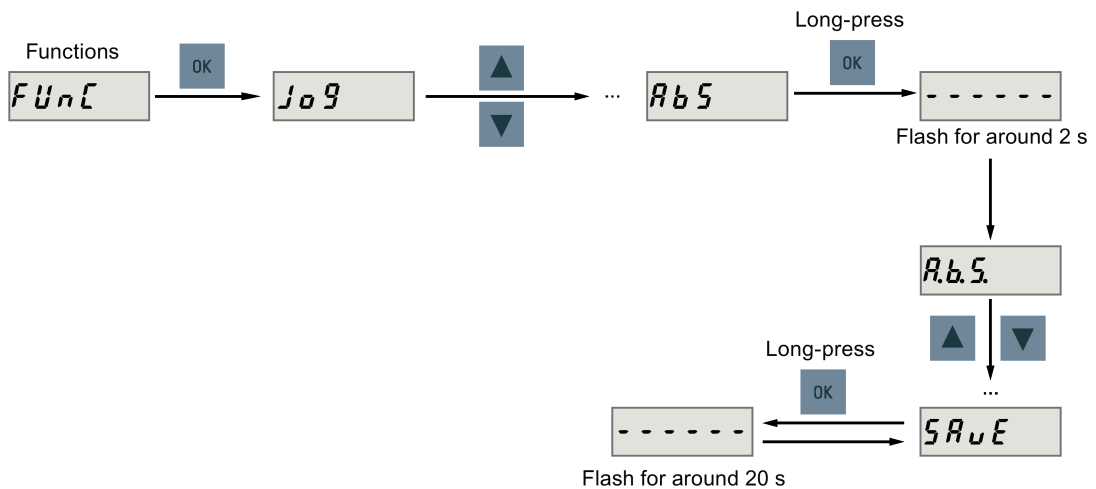

Note

Save parameter

The position value is set in parameter p2525. You **must** save the parameters after setting the zero position.

Control functions

7.1 Compound controls

Control modes

Nine control modes are available for the SINAMICS V90 servo drive:

| Control modes | | Abbreviation |
|------------------------|---|--------------|
| Basic control modes | Pulse train input position control mode (PTI) ¹⁾ | PTI |
| | Internal position control mode (IPos) | IPos |
| | Speed control mode (S) | S |
| | Torque control mode (T) | T |
| Compound control modes | Control change mode: PTI/S | PTI/S |
| | Control change mode: IPos/S | IPos/S |
| | Control change mode: PTI/T | PTI/T |
| | Control change mode: IPos/T | IPos/T |
| | Control change mode: S/T | S/T |

¹⁾ Default control mode

Selecting a basic control mode

You can select a basic control mode by directly setting parameter p29003:

| Parameter | Setting value | Description |
|-----------|---------------|---|
| p29003 | 0 (default) | Pulse train input position control mode |
| | 1 | Internal position control mode |
| | 2 | Speed control mode |
| | 3 | Torque control mode |

Control mode change for a compound control mode

For a compound control mode, you can change between two basic control modes by setting the parameter p29003 and configuring the level sensitive signal C-MODE on DI10:

| p29003 | C-MODE | |
|--------|----------------------------|-----------------------------|
| | 0 (the first control mode) | 1 (the second control mode) |
| 4 | PTI | S |
| 5 | IPos | S |
| 6 | PTI | T |

| p29003 | C-MODE | |
|--------|----------------------------|-----------------------------|
| | 0 (the first control mode) | 1 (the second control mode) |
| 7 | IPos | T |
| 8 | S | T |

Refer to Section "DIs (Page 61)" for detailed information about DIs.

Note

Note that if p29003 = 5 and the motor has been working in speed control mode for a certain period of time; or p29003 = 7 and the motor has been working in torque control mode for a certain period of time, the fault code F7493 might appear on the drive BOP. This, however, will not cause the motor to stop. The motor remains operative under this circumstance and you can clear the fault code manually.

Note

Fault F52904 occurs when the control mode is changed via p29003. You must save the parameter and then re-power on the servo drive to apply relevant configurations. For more information about the remedy and acknowledgement of this fault, refer to Section "List of faults and alarms (Page 255)".

Note

Switching conditions

For the switching from PTI or IPos to S or T, you are recommended to perform control mode switching after the INP (in position) signal is at high level.

For the switching from S or T to PTI or IPos, you can perform control mode switching only after the motor speed is lower than 30 rpm.

7.2 General functions

7.2.1 Servo ON

Servo ON signal (SON)

| Signal type | Signal name | Pin assignment | Setting | Description |
|-------------|-------------|------------------------|--------------------|--|
| DI | SON | X8-5 (factory setting) | ON = rising edge | Servo motor circuit is connected (servo is ON). Servo motor is ready to run. |
| | | | OFF = falling edge | Servo motor circuit is shut off (servo is OFF). Servo motor is not ready to run. |

Relevant parameter settings

| Parameter | Value setting | Description |
|-----------|---------------|--|
| p29301 | 1 | Signal SON (signal number: 1) is assigned to digital input 1 (DI1). |
| p29300 | bit 0 = 1 | Set SON at high level or rising edge forcedly. |



Note

Refer to Section "DIs (Page 61)" for detailed information about DI parameterization.

Refer to Chapter "Parameters (Page 219)" for detailed information about parameters.

7.2.2 Direction of motor rotation

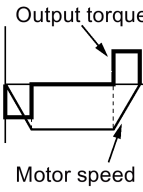
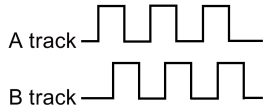
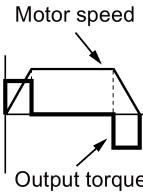
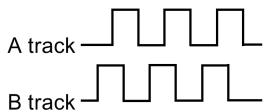
With parameter p29001, you can reverse the direction of rotation of the motor without changing the polarity of pulse train input setpoint and analog input setpoint. The polarity of output signals like pulse train encoder output (PTO) and analog monitoring remains unchanged at a reversal of direction.

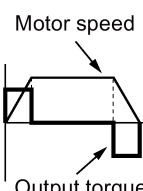
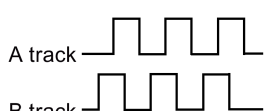
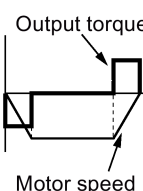
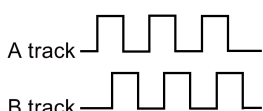
| Parameter | Value | Description | Setpoint | |
|-----------|-------|---|---|--|
| | | | Positive | Negative |
| p29001 | 0 | CW is forward direction (factory setting)  | <ul style="list-style-type: none"> Analog monitoring:  PTO:  | <ul style="list-style-type: none"> Analog monitoring:  PTO:  |
| | 1 | CCW is forward direction  | <ul style="list-style-type: none"> Analog monitoring:  PTO:  | <ul style="list-style-type: none"> Analog monitoring:  PTO:  |

 **WARNING**

The polarity of PTO cannot be changed at a reversal of the direction of motor rotation.

For an application of fully closed-loop position control using PTI and PTO, reverse wiring must be done for A track and B track of PTO.

Note

After modifying parameter p29001, you must save the parameter and then restart the drive to ensure normal operation. In this case, you must perform referencing again because the reference point will be lost after p29001 changes.

7.2.3 Over-travel

When the servo motor travels over distance limit, limit switch is turned on and servo motor then has an emergency stop.

Travel limit signals (CWL/CCWL)

NOTICE

Some important information about the travel limit signals (CWL/CCWL)

- Both of the signals **must** be at the high level when the servo drive is powered on.
- Operation is possible **only** when both **CWL** and **CCWL** are at the high level (logic 1).
- In all the modes, signal **CWL/CCWL** can be responded, which means when F7492 or F7491 happens, the motor can run over the travel limit if the fault is acknowledged.
 - For a positive traversing direction, if the STOP cam plus is reached, F7492 will happen. To clear the fault, acknowledge it with CLR, and then leave away from the STOP cam plus in the negative traversing direction to return the axis to the valid traversing range.
 - For a negative traversing direction, if the STOP cam minus is reached, F7491 will happen. To clear the fault, acknowledge it with CLR, and then leave away from the STOP cam minus in the positive traversing direction to return the axis to the valid traversing range.

Signal **CWL** functions as the clockwise travel limit while signal **CCWL** functions as the counter-clockwise travel limit. Both of them are level and edge sensitive signals.

| Signal type | Signal name | Pin assignment | Setting | Description |
|-------------|-------------|------------------------|--------------------|---|
| DI | CWL | X8-7 (factory setting) | Falling edge (1→0) | Servo motor has traveled to clockwise travel limit. Servo motor has an emergency stop after that. |
| DI | CCWL | X8-8 (factory setting) | Falling edge (1→0) | Servo motor has traveled to counter-clockwise travel limit. Servo motor has an emergency stop after that. |

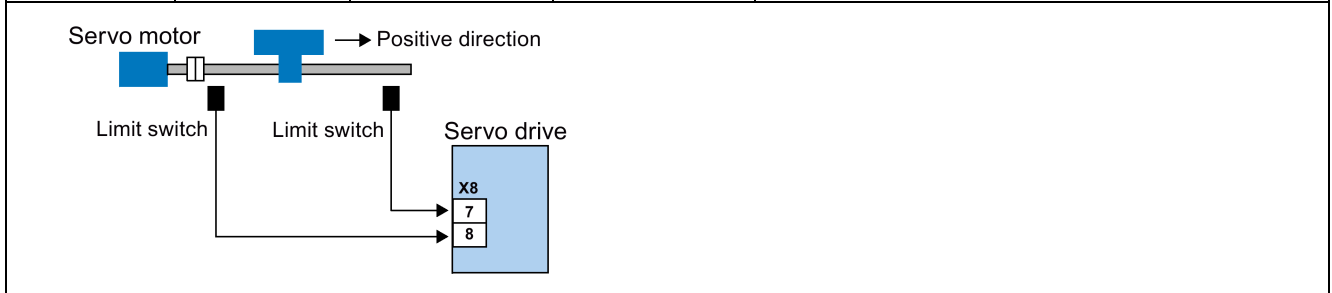

Relevant parameter settings

| Parameter | Value setting | Description |
|-----------|---------------|---|
| p29303 | 3 | Signal CWL (signal number: 3) is assigned to digital input 3 (DI3). |
| p29304 | 4 | Signal CCWL (signal number: 4) is assigned to digital input 4 (DI4). |
| p29300 | bit 1 = 1 | Set CWL at high level or rising edge forcedly. |
| | bit 2 = 1 | Set CCWL at high level or rising edge forcedly. |

Note

DI parameterization

Refer to Section "DIs (Page 61)" for detailed information about DI parameterization.

Refer to Chapter "Parameters (Page 219)" for detailed information about parameters.

7.2.4 Motor holding brake

A holding brake is used to hold the position of the servo motor when the motor power is cut off. The servo motor can move because of its own weight or an external force even the motor power has been cut off.

Holding brake is built in servo motors with brakes.

Note

- The brake built in the servo motor with brakes is a de-energization brake. It is used **only** to hold the servo motor and cannot be used for motor braking. Use the holding brake only to hold a stopped motor.
- The holding brake is activated at the same time when the motor power is cut off.
- Refer to Section "System connection (Page 55)" for the standard wiring of the holding brake.

DO setting

| Signal type | Signal name | Pin assignment | Setting | Description |
|-------------|-------------|-------------------------|---------------------|----------------------------------|
| DO | MBR | X8-35 (factory setting) | ON = high level (1) | Motor holding brake is closed. |
| | | | OFF = low level (0) | Motor holding brake is released. |

You can also change the assignment of the digital output signal MBR and assign it to any DO pin with one of the following parameters:

| Parameter | Range | Factory setting | Unit | Description |
|-----------|---------|-----------------|------|--------------------------------|
| p29330 | 1 to 13 | 1 (RDY) | - | Assignment of digital output 1 |
| p29331 | 1 to 13 | 2 (ALM) | - | Assignment of digital output 2 |
| p29332 | 1 to 13 | 3 (INP) | - | Assignment of digital output 3 |
| p29333 | 1 to 13 | 5 (SPDR) | - | Assignment of digital output 4 |
| p29334 | 1 to 13 | 6 (TLR) | - | Assignment of digital output 5 |
| p29335 | 1 to 13 | 8 (MBR) | - | Assignment of digital output 6 |

Note

Refer to Section "DOs (Page 66)" for detailed information about the digital outputs.

Braking sequence

The operating principle of the holding brake is configured during motor selection for motors with incremental encoders and configured automatically for motors with absolute encoders.

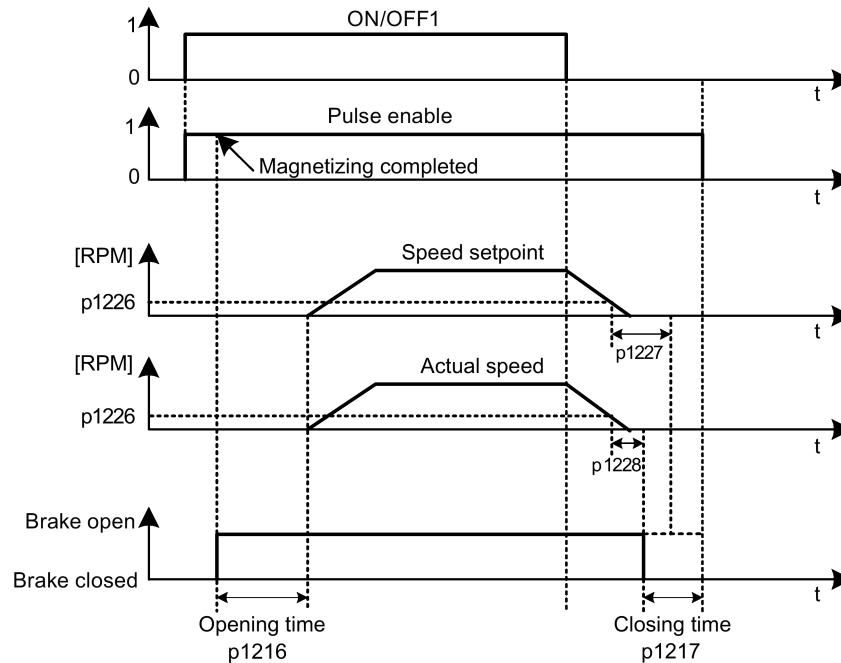

The start of the closing time for the brake depends on the expiration of the shorter of p1227 (zero speed detection monitoring time) and p1228 (pulse suppression delay time).

Parameter setting

You can configure the holding brake with the parameter p1215 according to the actual application.

| Parameter | Range | Factory setting | Unit | Description |
|-----------|--------|-----------------|------|--|
| p1215 | 0 to 3 | 0 | - | Configuration of the holding brake. <ul style="list-style-type: none"> • 0: No holding brake available • 1: Motor holding brake according to sequence control (SON) • 2: Motor holding brake always open • 3: SIEMENS internal use |

When you set p1215=1, the motor holding brake is open once the digital input signal SON has a rising edge and becomes closed once a falling edge comes to SON.

If the servo motor is used to control a vertical axis, the machine movable part can have a slight shift when the holding brake becomes open or closed simultaneously with the action of SON. To eliminate such slight shift, you can configure a delay time for the close or open time of the motor holding brake by setting the following parameters:

| Parameter | Range | Factory setting | Unit | Description |
|-----------|------------------|-----------------|------|---------------------------------------|
| p1216 | 0.00 to 10000.00 | 100 | ms | Motor holding brake open delay time. |
| p1217 | 0.00 to 10000.00 | 100 | ms | Motor holding brake close delay time. |

7.2.5 Stopping method at servo OFF

You can select a stopping method when the servo is OFF. The following stopping methods are available:

- Ramp-down (OFF1)
- Coast-down (OFF2)
- Emergency stop (OFF3)

Ramp-down (OFF1) and coast-down (OFF2)

The ramp-down and coast-down can be configured with the digital input signal SON:

SON in PTI, IPos or S mode

| Signal type | Signal name | Pin assignment | Setting | Description |
|-------------|-------------|------------------------|--------------------|--|
| DI | SON | X8-5 (factory setting) | Rising edge (0→1) | Power circuit is powered on and the servo drive is ready to run. |
| | | | Falling edge (1→0) | Motor ramps down. |

SON in T mode

| Signal type | Signal name | Pin assignment | Setting | Description |
|-------------|-------------|------------------------|--------------------|--|
| DI | SON | X8-5 (factory setting) | Rising edge (0→1) | Power circuit is powered on and the servo drive is ready to run. |
| | | | Falling edge (1→0) | Motor coasts down. |

Emergency stop (OFF3)

The emergency stop can be configured with the digital input signal EMGS.

| Signal type | Signal name | Pin assignment | Setting | Description |
|-------------|-------------|----------------|---------|------------------------------|
| DI | EMGS | X8-13 (fixed) | 1 | Servo drive is ready to run. |
| | | | 0 | Emergency stop. |

For detailed information about the digital input signals SON and EMGS, refer to Section "DIs (Page 61)".

7.3 Pulse train input position control (PTI)

7.3.1 Selecting a setpoint pulse train input channel

As mentioned before, the SINAMICS V90 servo drive supports two channels for the setpoint pulse train input:

- 24 V single end pulse train input
- High-speed 5 V differential pulse train input

You can select one of these two channels by setting the parameter p29014:

| Parameter | Value | Setpoint pulse train input channel | Default |
|-----------|-------|---|---------|
| p29014 | 0 | High-speed 5 V differential pulse train input | |
| | 1 | 24 V single end pulse train input | ✓ |

The position pulse train inputs come from either of the following two terminal groups:

- X8-1 (PTIA_D+), X8-2 (PTIA_D-), X8-26 (PTIB_D+), X8-27 (PTIB_D-)
- X8-36 (PTI_A_24P), X8-37 (PTI_A_24M), X8-38 (PTI_B_24P), X8-39 (PTI_B_24M)

For more information about wiring, refer to Section "PTIs (Page 69)".

7.3.2 Selecting a setpoint pulse train input form

The SINAMICS V90 servo drive supports two kinds of setpoint pulse train input forms:

- AB track pulse
- Pulse + Direction

For both forms, positive logic and negative logic are supported:

| Pulse train input form | Positive logic = 0 | | Negative logic = 1 | |
|------------------------|--------------------|---------------|--------------------|--------------|
| | Forward (CW) | Reverse (CCW) | Forward (CCW) | Reverse (CW) |
| AB track pulse | | | | |
| Pulse + Direction | | | | |

7.3 Pulse train input position control (PTI)

You can select one of the setpoint pulse train input forms by setting the parameter p29010:

| Parameter | Value | Setpoint pulse train input form | Default |
|-----------|-------|-----------------------------------|---------|
| p29010 | 0 | Pulse + Direction, positive logic | ✓ |
| | 1 | AB track, positive logic | |
| | 2 | Pulse + Direction, negative logic | |
| | 3 | AB track, negative logic | |

Note

After modifying parameter p29010, you must save the parameter and then restart the drive to ensure normal operation. In this case, you must perform referencing again because the reference point will be lost after p29010 changes.

7.3.3 In position (INP)

When the deviation between the position setpoint and the actual position is within the preset in-position range specified in p2544, the signal INP (in position) is output.

Parameter settings

| Parameter | Value range | Setting value | Unit | Description |
|-----------|-----------------|---------------|------|-------------------------------------|
| p2544 | 0 to 2147483647 | 40 (default) | LU | Position window (in-position range) |
| p29332 | 1 to 13 | 3 | - | Digital output 3 assignment |

DO configuration

| Signal type | Signal name | Pin assignment | Setting | Description |
|-------------|-------------|----------------|---------|---|
| DO | INP | X8-32 | 1 | Number of droop pulses is in the preset in-position range (parameter p2544) |
| | | | 0 | Droop pulses are beyond the in-position range |

7.3.4 Smoothing function

With the smoothing function, the position characteristics curve from the pulse train input setpoint can be transformed into an S-curve profile with a time constant specified in p2533.

Parameter setting

| Parameter | Range | Factory setting | Unit | Description |
|-----------|-----------|-----------------|------|---|
| p2533 | 0 to 1000 | 0 | ms | Smooths the parameter in response to a sudden position setpoint |

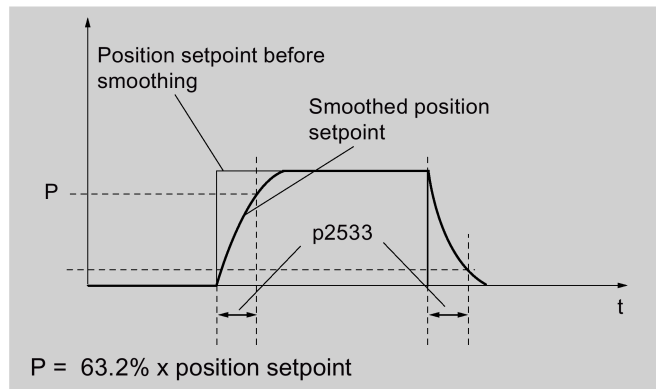

7.3.5 Electronic gear ratio

Encoder specifications

The encoder specifications are shown as follows:

1FL6□□□ -1A□61-0□□1



| Type | Specification | Resolution (ppr) |
|------|---------------------|------------------|
| A | Incremental encoder | 2500 |
| L | Absolute encoder | 20 bit |

Electronic gear

With the function of electronic gear, you can define the motor revolutions according to the number of setpoint pulses, and sequentially define the distance of mechanical movement. The minimum travelling distance of load shaft according to one setpoint pulse is called a length unit (LU); for example, one pulse results in 1 µm movement.

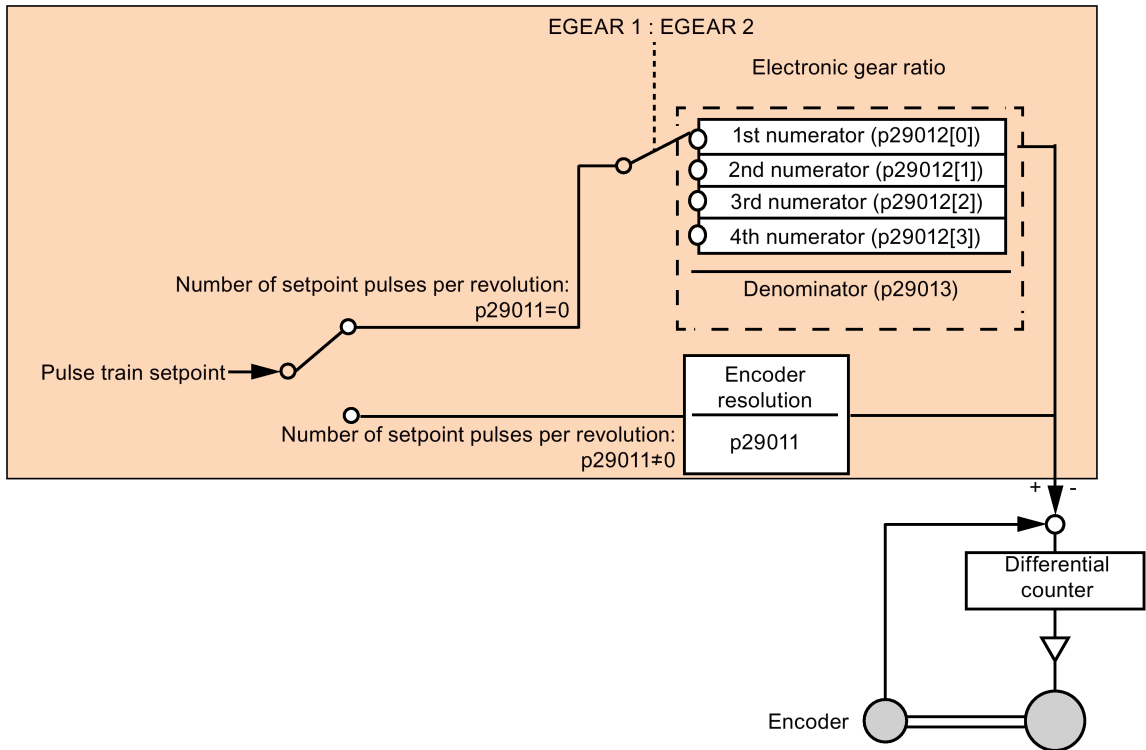

Benefits of electronic gear (example):

Move the workpiece for 10 mm:

LU: 1 µm

Encoder resolution: 2500 ppr

Pitch of ball screw: 6 mm

Workpiece

| Without electronic gear | With electronic gear |
|--|--|
| Required number of setpoint pulses: 2500 ppr × 4 × (10 mm/6 mm) = 16666 | Required number of setpoint pulses: (10 mm × 1000) / 1 LU = 10000 |

The electronic gear ratio is a multiplier factor to pulse train setpoint. It is realized with a numerator and a denominator. Four numerators (p29012[0], p29012[1], p29012[2], p29012[3]) and one denominator (p29013) are used for the four electronic gear ratios:

| Parameter | Range | Factory setting | Unit | Description |
|-----------|------------|-----------------|------|---|
| p29012[0] | 1 to 10000 | 1 | - | The first numerator of electronic gear |
| p29012[1] | 1 to 10000 | 1 | - | The second numerator of electronic gear |

| Parameter | Range | Factory setting | Unit | Description |
|-----------|------------|-----------------|------|--|
| p29012[2] | 1 to 10000 | 1 | - | The third numerator of electronic gear |
| p29012[3] | 1 to 10000 | 1 | - | The forth numerator of electronic gear |
| p29013 | 1 to 10000 | 1 | - | The denominator of electronic gear |

These four electronic gear ratios can be selected with the combination of the digital input signals EGEAR1 and EGEAR2 (refer to Section "DIs (Page 61)"):

| EGEAR2 : EGEAR1 | Electronic gear ratio | Ratio value |
|-----------------|-------------------------|--------------------|
| 0 : 0 | Electronic gear ratio 1 | p29012[0] : p29013 |
| 0 : 1 | Electronic gear ratio 2 | p29012[1] : p29013 |
| 1 : 0 | Electronic gear ratio 3 | p29012[2] : p29013 |
| 1 : 1 | Electronic gear ratio 4 | p29012[3] : p29013 |

Note

After a gear ratio is switched to another one via digital inputs, you need to wait five seconds and then perform **SERVO ON**.

Note

The range of electronic gear ratio is from 0.02 to 200.

The electronic gear ratio can be set at **SERVO OFF** state only.

Calculation formula for electronic gear ratio

The electronic gear ratio can be calculated from the formula below:

$$\frac{a}{b} = \frac{p29012}{p29013} : \text{electronic gear ratio}$$

c: pitch of ball screw

$$\frac{n}{m} : \text{deduction gear ratio}$$

$$\frac{c}{LU} \times \frac{a}{b} = r \times \frac{n}{m}$$

$$\frac{a}{b} = \frac{rLU}{c} \times \frac{n}{m}$$

Examples for calculating the electronic gear ratio

| Step | Description | Mechanism | |
|------|---|--|---|
| | | Ball screw | Disc table |
| | | LU: 1 μm Encoder resolution: 2500 ppr Pitch of ball screw: 6 mm | LU: 0.01° Encoder resolution: 2500 ppr |
| 1 | Identify mechanism | <ul style="list-style-type: none"> Pitch of ball screw: 6 mm Deduction gear ratio: 1:1 | <ul style="list-style-type: none"> Rotary angle: 360° Deduction gear ratio: 3:1 |
| 2 | Identify encoder resolution | 10000 | 10000 |
| 3 | Define LU | 1 LU=1 μm | 1 LU=0.01° |
| 4 | Calculate the travel distance per load shaft revolution | 6/0.001=6000 LU | 360°/0.01°=36000 LU |
| 5 | Calculate electronic gear ratio | $(1/6000) \times (1/1) \times 10000 = 10000/6000$ | $(1/36000) \times (3/1) \times 10000 = 10000/12000$ |
| 6 | Set parameters | p29012/p29013 $= 10000/6000 = 5/3$ | $= 10000/12000 = 5/6$ |

7.3.6 Inhibiting pulse train input setpoint (P-TRG)

Note

P-TRG in PTI mode

Note that the function "inhibiting pulse train by P-TRG in PTI mode" as described in this section and the rest of the manual is reserved for future use.

The digital input signal P-TRG is the default connection of DI6 in the position control mode. In the pulse train input position control mode, P-TRG is level sensitive and can be used to allow or inhibit positioning operation according to pulse train input setpoint:

- 0: positioning according to pulse train input setpoint
- 1: inhibit pulse train input setpoint

Timing diagram

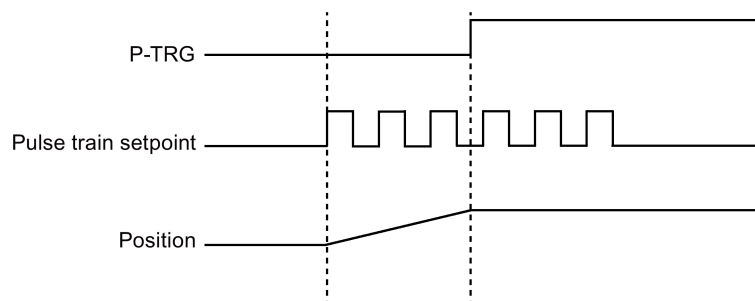

DI configuration

The signal P-TRG is the factory setting of DI6:

| Signal type | Signal name | Pin assignment | Setting | Description |
|-------------|-------------|-------------------------|----------------|---|
| DI | P-TRG | X8-10 (factory setting) | High level (1) | Inhibit pulse train input setpoint |
| | | | Low level (0) | Positioning according to pulse train input setpoint |

Note

Refer to Section "DIs (Page 61)" for detailed information about DI parameterization.

- The signal P-TRG is active only when the digital input signal SON is in OFF state.
 - When the signal P-TRG is active in the PTI mode or a compound mode with PTI, the alarm A7585 occurs.
-

7.3.7 Speed limit

Four sources in total are available for the speed limit. You can select one of them via a combination of digital input signals SLIM1 and SLIM2:

| Digital signal | | Speed limit |
|----------------|-------|---------------------------------------|
| SLIM2 | SLIM1 | |
| 0 | 0 | Internal speed limit 1 |
| 0 | 1 | External speed limit (analog input 1) |
| 1 | 0 | Internal speed limit 2 |
| 1 | 1 | Internal speed limit 3 |

Note

Control mode

The above four sources are valid in all control modes. You can switch among them when the servo drive is running.

Note

Fault F7901 occurs when the actual speed exceeds the positive speed limit + hysteresis speed (p2162) or the negative speed limit - hysteresis speed (p2162). Go to "List of faults and alarms (Page 255)" for information about the acknowledgment of this fault.

Refer to "DIs (Page 61)" for more information about the digital input signals SLIM1 and SLIM2.

Overall speed limit

Besides the above four channels, an overall speed limit is also available for all control modes.

The overall speed limit can be configured by setting the following parameters:

| Parameter | Value range | Default | Unit | Description |
|-----------|--------------|---------|------|--------------------------------|
| p1083 | 0 to 210000 | 210000 | rpm | Overall speed limit (positive) |
| p1086 | -210000 to 0 | -210000 | rpm | Overall speed limit (negative) |

Internal speed limit

Select an internal speed limit by setting the following parameters:

| Parameter | Value range | Default | Unit | Description | Digital input | |
|-----------|-------------|---------|------|-----------------------------------|---------------|-------|
| | | | | | SLIM2 | SLIM1 |
| p29070[0] | 0 to 210000 | 210000 | rpm | Internal speed limit 1 (positive) | 0 | 0 |
| p29070[1] | 0 to 210000 | 210000 | rpm | Internal speed limit 2 (positive) | 1 | 0 |
| p29070[2] | 0 to 210000 | 210000 | rpm | Internal speed limit 3 (positive) | 1 | 1 |

| Parameter | Value range | Default | Unit | Description | Digital input | |
|-----------|--------------|---------|------|-----------------------------------|---------------|-------|
| | | | | | SLIM2 | SLIM1 |
| p29071[0] | -210000 to 0 | -210000 | rpm | Internal speed limit 1 (negative) | 0 | 0 |
| p29071[1] | -210000 to 0 | -210000 | rpm | Internal speed limit 2 (negative) | 1 | 0 |
| p29071[2] | -210000 to 0 | -210000 | rpm | Internal speed limit 3 (negative) | 1 | 1 |

Note

After the motor is commissioned, p29070 and p29071 set to the maximum speed of the motor automatically.

External speed limit

Select an external speed limit by setting the following parameters:

| Parameter | Value range | Default | Unit | Description |
|-----------|---------------|---------|------|--|
| p29060 | 6 to 210000 | 3000 | rpm | Scaling for analog speed setpoint (maximum speed setpoint corresponding to 10 V) |
| p29061 | -0.50 to 0.50 | 0 | V | Offset adjustment for analog input 1 (speed setpoint) |

7.3.8 Torque limit

Four sources in total are available for the torque limit. You can select one of them via a combination of digital input signals TLIM1 and TLIM2:

| Digital signal | | Torque limit |
|----------------|-------|--|
| TLIM2 | TLIM1 | |
| 0 | 0 | Internal torque limit 1 |
| 0 | 1 | External torque limit (analog input 2) |
| 1 | 0 | Internal torque limit 2 |
| 1 | 1 | Internal torque limit 3 |

When the torque setpoint reaches torque limit, the torque is limited to the value selected by TLIM1/TLIM2.

Note**Control mode**

The above four sources are valid in the PTI mode, the IPos mode and the S mode. You can switch among them when the servo drive is running.

Refer to "DIs (Page 61)" for more information about the digital input signals TLIM1 and TLIM2.

Overall torque limit

Besides the above four sources, an overall torque limit is also available for **all** control modes. The overall torque limit takes effect when an emergency stop (OFF3) happens. In this case, the servo drive brakes with a maximum torque.

Parameter settings:

| Parameter | Value range | Default | Unit | Description |
|-----------|----------------------------|---------|------|---------------------------------|
| p1520 | -1000000.00 to 20000000.00 | 0 | Nm | Overall torque limit (positive) |
| p1521 | -20000000.00 to 1000000.00 | 0 | Nm | Overall torque limit (negative) |

Internal torque limit

Select an internal torque limit by setting the following parameters:

| Parameter | Value range | Default | Unit | Description | Digital input | |
|-----------|-------------|---------|------|------------------------------------|---------------|-------|
| | | | | | TLIM1 | TLIM2 |
| p29043 | -100 to 100 | 0 | % | Fixed torque setpoint | - | - |
| p29050[0] | -150 to 300 | 300 | % | Internal torque limit 1 (positive) | 0 | 0 |
| p29050[1] | -150 to 300 | 300 | % | Internal torque limit 2 (positive) | 1 | 0 |
| p29050[2] | -150 to 300 | 300 | % | Internal torque limit 3 (positive) | 1 | 1 |
| p29051[0] | -300 to 150 | -300 | % | Internal torque limit 1 (negative) | 0 | 0 |
| p29051[1] | -300 to 150 | -300 | % | Internal torque limit 2 (negative) | 1 | 0 |
| p29051[2] | -300 to 150 | -300 | % | Internal torque limit 3 (negative) | 1 | 1 |

The following diagram shows how the internal torque limit functions:

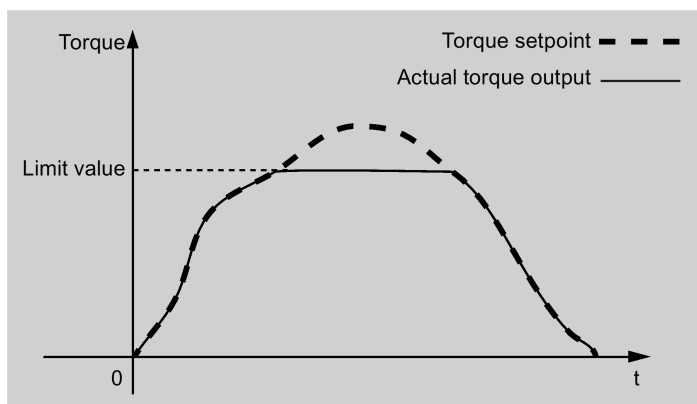

External torque limit

Parameter settings:

| Parameter | Value range | Default | Unit | Description | Digital input | |
|-----------|-------------|---------|------|--|---------------|-------|
| | | | | | TLIM1 | TLIM2 |
| p29041[1] | 0 to 300 | 300 | % | Analog torque limit scaling (value corresponding to 10V) | 0 | 1 |

p29041[1] is the scaling of analog input 2.

For example, if p29041[1] is 100%, the relationship between torque limit value and analog input is shown as follows:

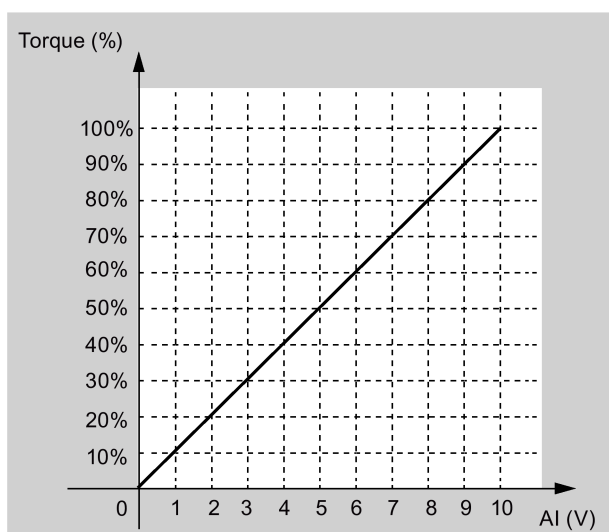

In this case, analog input of 5 V corresponds to 50% of rated torque and 10 V corresponds to 100% of rated torque.

Torque limit reached (TLR)

When the generated torque has nearly (internal hysteresis) reached the value of the positive torque limit, negative torque limit or analog torque limit, the signal TLR is output.

7.3.9 Clearing droop pulses (CLR)

The droop pulses can be cleared with the parameter p29242 or the digital input signal CLR.

Clearing droop pulses automatically with p29242

You can choose to clear the droop pulses automatically by setting the parameter p29242:

| Parameter | Range | Factory setting | Unit | Description |
|-----------|--------|-----------------|------|--|
| p29242 | 0 to 1 | 0 | - | Clear droop pulses automatically: <ul style="list-style-type: none"> 0: droop pulses are automatically cleared at servo ON 1: clear droop pulses manually with the DI signal CLR |

Clearing droop pulses manually with DI signal CLR

You can choose to clear the droop pulses manually with the DI signal CLR. The signal CLR is the factory setting of pin 11 (DI7) on the interface X8:

| Signal type | Signal name | Pin assignment | Setting | Description |
|-------------|-------------|----------------|---------|---|
| DI | CLR | X8-11 | 0 | Don't clear the position control droop pulses |
| | | | 1 | Always clear the position control droop pulses. |
| | | | | |

Note

- The signal CLR is active only when the digital input signal SON is in OFF state.
- When the signal CLR is active in the PTI mode or a compound mode with PTI, the alarm A7585 occurs.

7.3.10 Referencing (only for absolute encoder)

If an absolute encoder is used, you must adjust the absolute encoder with the BOP menu function "ABS". For detailed information about "ABS" menu function, refer to "Adjusting an absolute encoder (Page 126)".

7.3.11 PTO function

Function

A pulse train encoder output (PTO) which provides pulse signals can transmit the signals to the controller to realize a closed-loop control system inside the controller, or transmit them to another drive as pulse train setpoint for a synchronous axis.

Electronic gear

The electronic gear ratio is a multiplier factor to the PTO to a controller. It is realized with a numerator and a denominator. One numerator (p29031) and one denominator (p29032) are used for the PTO electronic gear ratio:

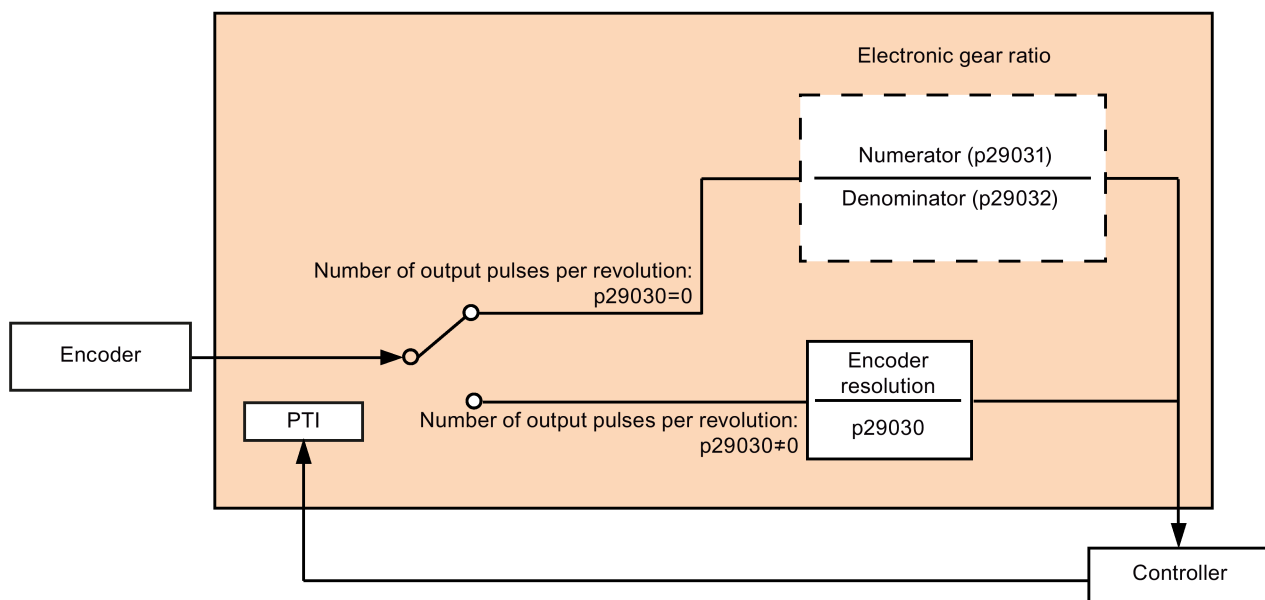

| Parameter | Range | Factory setting | Unit | Description |
|-----------|-----------------|-----------------|------|-----------------------------|
| p29031 | 1 to 2147000000 | 1 | - | Numerator of output pulse |
| p29032 | 1 to 2147000000 | 1 | - | Denominator of output pulse |

Note

The range of electronic gear ratio is from 0.02 to 200.

The electronic gear ratio can be set at **SERVO OFF** state only.

PTO zero mark

Make the servo motor rotate for more than one revolution before using PTO's zero mark for referencing.

7.4 Internal position control (IPos)

7.4.1 Setting mechanical system

By parameterizing the mechanical system, the link between the physical moving part and the length unit (LU) is established.

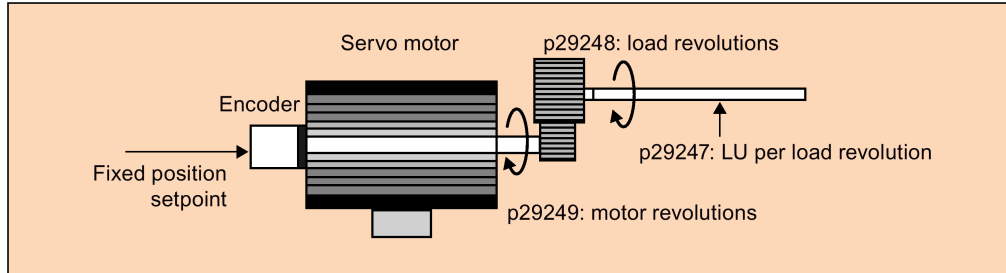

The unit of the fixed position setpoint is the Length Unit (LU). All subsequent position setpoint, related speed value, and acceleration value will maintain the LU as the unit in internal position control mode.

Taking a ball screw system for example, if the system has a pitch of 10 mm/revolution (10000 μm /revolution) and the resolution of the length unit is 1 μm (1 LU = 1 μm), one load revolution corresponds to 10000 LU (p29247 = 10000).

Note

If the value of p29247 increases by N times, the values of p2542, p2544 and p2546 should increase by N times accordingly. Otherwise, the fault F7450 or F7452 occur.

Relevant parameters

| Parameter | Range | Factory setting | Unit | Description |
|-----------|-----------------|-----------------|------|------------------------|
| p29247 | 1 to 2147483647 | 10000 | - | LU per load revolution |
| p29248 | 1 to 1048576 | 1 | - | Load revolutions |
| p29249 | 1 to 1048576 | 1 | - | Motor revolutions |

Examples for configuring mechanical system

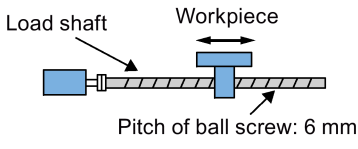
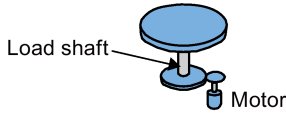
| Step | Description | Mechanical system | |
|------|--|--|---|
| | | Ball screw | Disc table |
| | |  |  |
| 1 | Identify the mechanical system | <ul style="list-style-type: none"> Pitch of ball screw: 6 mm Reduction gear ratio: 1:1 | <ul style="list-style-type: none"> Rotary angle: 360° Reduction gear ratio: 3:1 |
| 2 | Define LU | 1 LU = 1 µm | 1 LU = 0.01° |
| 3 | Calculate the LU per load shaft revolution | 6/0.001 = 6000 LU | 360/0.01 = 36000 LU |
| 4 | Set parameters | p29247 | 6000 |
| | | p29248 | 1 |
| | | p29249 | 1 |

7.4.2 Setting fixed position setpoint

Eight position setpoints in total are available. Each position setpoint comes from one group of position data:

| Fixed position setpoint | Corresponding parameters | |
|---------------------------|--------------------------|---|
| | Parameter | Description |
| Fixed position setpoint 1 | p2617[0] | Fixed position setpoint 1 (P_pos1) |
| | p2618[0] | Speed of fixed position setpoint 1 (P_pos_spd1) |
| | p2572 | IPos maximum acceleration |
| | p2573 | IPos maximum deceleration |
| Fixed position setpoint 2 | p2617[1] | Fixed position setpoint 2 (P_pos2) |
| | p2618[1] | Speed of fixed position setpoint 2 (P_pos_spd2) |
| | p2572 | IPos maximum acceleration |
| | p2573 | IPos maximum deceleration |
| Fixed position setpoint 3 | p2617[2] | Fixed position setpoint 3 (P_pos3) |
| | p2618[2] | Speed of fixed position setpoint 3 (P_pos_spd3) |
| | p2572 | IPos maximum acceleration |
| | p2573 | IPos maximum deceleration |
| Fixed position setpoint 4 | p2617[3] | Fixed position setpoint 4 (P_pos4) |
| | p2618[3] | Speed of fixed position setpoint 4 (P_pos_spd4) |
| | p2572 | IPos maximum acceleration |
| | p2573 | IPos maximum deceleration |

7.4 Internal position control (IPos)

| Fixed position setpoint | Corresponding parameters | |
|---------------------------|--------------------------|---|
| | Parameter | Description |
| Fixed position setpoint 5 | p2617[4] | Fixed position setpoint 5 (P_pos5) |
| | p2618[4] | Speed of fixed position setpoint 5 (P_pos_spd5) |
| | p2572 | IPos maximum acceleration |
| | p2573 | IPos maximum deceleration |
| Fixed position setpoint 6 | p2617[5] | Fixed position setpoint 6 (P_pos6) |
| | p2618[5] | Speed of fixed position setpoint 6 (P_pos_spd6) |
| | p2572 | IPos maximum acceleration |
| | p2573 | IPos maximum deceleration |
| Fixed position setpoint 7 | p2617[6] | Fixed position setpoint 7 (P_pos7) |
| | p2618[6] | Speed of fixed position setpoint 7 (P_pos_spd7) |
| | p2572 | IPos maximum acceleration |
| | p2573 | IPos maximum deceleration |
| Fixed position setpoint 8 | p2617[7] | Fixed position setpoint 8 (P_pos8) |
| | p2618[7] | Speed of fixed position setpoint 8 (P_pos_spd8) |
| | p2572 | IPos maximum acceleration |
| | p2573 | IPos maximum deceleration |

Parameter settings

| Parameter | Range | Factory setting | Unit | Description |
|----------------|---------------------------|-----------------|------------------------|---|
| p2617[0]...[7] | -2147482648 to 2147482647 | 0 | LU | Fixed position setpoint 1 to 8 |
| p2618[0]...[7] | 1 to 40000000 | 600 | 1000 LU/min | Speed of fixed position setpoint 1 to 8 |
| p2572 | 1 to 2000000 | Motor dependent | 1000 LU/s ² | IPos maximum acceleration |
| p2573 | 1 to 2000000 | Motor dependent | 1000 LU/s ² | IPos maximum deceleration |

7.4.3 Selecting a positioning mode - absolute/incremental

In the internal position control mode, you can select between absolute positioning mode and incremental positioning mode with the parameter p29241:

| Parameter | Range | Factory setting | Unit | Description |
|-----------|--------|-----------------|------|---|
| p29241 | 0 to 3 | 0 | - | Absolute or incremental positioning mode: <ul style="list-style-type: none"> • 0: incremental • 1: absolute • 2: absolute, positive (only for a rotary axis with modulo correction) • 3: absolute, negative (only for a rotary axis with modulo correction) |

NOTICE

Pre-conditions for using the absolute mode

The absolute mode can be used only after:

- the axis has been referenced for incremental measuring system. Refer to Section "Referencing (Page 153)" for detailed information about referencing.
- the axis has been adjusted for absolute measuring system. Refer to Section "Adjusting an absolute encoder (Page 126)" for reference.

Example

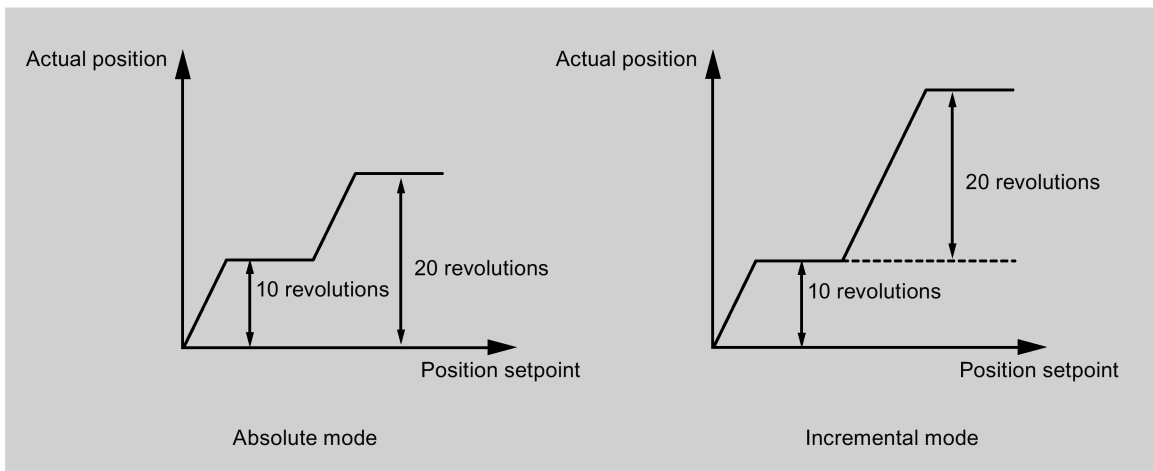

7.4.4 Configuring linear/modular axis

Linear axis or modular axis can be used depending on your actual application. The linear axis has a restricted traversing range and it is the factory setting of the SINAMICS V90 servo drive.

The modular axis has an unrestricted traversing range. The value range of the position repeats itself after a value specified in p29245. You can use the modular axis by setting the following parameters additionally:

| Parameter | Range | Unit | Default | Description |
|-----------|-----------------|------|---------|--|
| p29245 | 0 to 1 | - | 0 | <ul style="list-style-type: none"> 0: linear axis 1: modular axis activation |
| p29246 | 1 to 2147482647 | LU | 360000 | Modular range |

Note

After modifying parameter p29245, you must perform the referencing again.

7.4.5 Backlash compensation

Generally, backlash occurs when the mechanical force is transferred between a machine part and its drive:

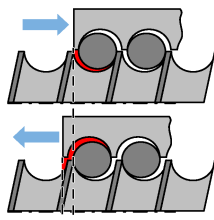

Backlash: p2583

If the mechanical system was to be adjusted/designed so that there was absolutely no backlash, this would result in high wear. Thus, backlash can occur between the machine component and the encoder. For axes with indirect position sensing, mechanical backlash results in a false traversing distance because the axis, at direction reversal, travels either too far or not far enough corresponding to the absolute value of the backlash.

Note

Pre-conditions for backlash compensation

The backlash compensation is active after

- the axis has been referenced for incremental measuring system. Refer to Section "Referencing (Page 153)" for detailed information about referencing.
- the axis has been adjusted for absolute measuring system. Refer to Section "Adjusting an absolute encoder (Page 126)" for reference.

In order to compensate the backlash, the determined backlash must be specified in p2583 with correct polarity. At each direction of rotation reversal, the axis actual value is corrected dependent on the actual traversing direction.

If the axis has been referenced or adjusted, then the setting of parameter p2604 (reference point approach, starting direction) is used to activate the compensation value:

| p2604 | Traversing direction | Activate compensation value |
|-------|----------------------|-----------------------------|
| 0 | Negative | Immediately |
| 1 | Positive | Immediately |

Parameter settings

| Parameter | Range | Unit | Default | Description |
|-----------|-------------------|------|---------|--|
| p2583 | -200000 to 200000 | LU | 0 | Backlash compensation |
| p2604 | 0 to 1 | - | 0 | Set signal source for start direction of searching cam: <ul style="list-style-type: none"> 0: start in positive direction 1: start in negative direction |

7.4.6 Referencing

Referencing modes

If the servo motor has an absolute encoder, you can adjust the absolute encoder (by setting current position as the zero position) with the BOP function "ABS". Refer to Section "Adjusting an absolute encoder (Page 126)" for details.

If the servo motor has an incremental encoder, five referencing modes in total are available:

- Setting reference point with the digital input signal REF
- External reference cam (signal REF) and encoder zero mark
- Encoder zero mark only
- External reference cam (signal CWL) and encoder zero mark
- External reference cam (signal CCWL) and encoder zero mark

You can select one of these referencing modes by setting the parameter p29240:

| Parameter | Value | Description |
|-----------|-------------|--|
| p29240 | 0 | Setting reference point with the digital input signal REF |
| | 1 (default) | External reference cam (signal REF) and encoder zero mark |
| | 2 | Encoder zero mark only |
| | 3 | External reference cam (signal CCWL) and encoder zero mark |
| | 4 | External reference cam (signal CWL) and encoder zero mark |

| |
|--|
| NOTICE |
| p29240 is inactive for absolute encoder |
| If an absolute encoder is connected, the parameter p29240 is inactive. |

Setting reference point with the digital input signal REF (p29240=0)

| |
|---|
| NOTICE |
| Preconditions for this referencing mode |
| <ul style="list-style-type: none">• The servo motor must be stopped.• The signal REF must be OFF under the following conditions:<ul style="list-style-type: none">– before power-on– when switching from another referencing mode to this referencing mode– when switching from another control mode to internal position control mode |

The current position is set to zero at a rising edge of the signal REF and the servo drive is referenced:

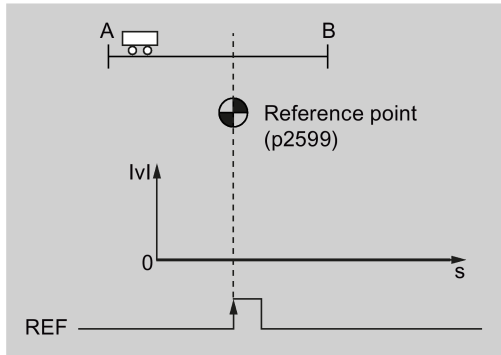

| |
|--|
| ⚠ CAUTION |
| The referencing point may not be fixed during referencing. |
| The servo motor must be in servo on state so that the referencing point is fixed during referencing. |

External reference cam (signal REF) and encoder zero mark (p29240=1)

The referencing is triggered by signal SREF. After that, the servo motor accelerates to the speed specified in p2605 to find the reference cam. The direction (CW or CCW) for searching the reference cam is defined by p2604. When the reference cam is reached (signal REF: 0→1), the servo motor decelerates to standstill. After that, the servo motor accelerates again to the speed specified in p2608 and the running direction is opposite to the direction defined by p2604. Then the signal REF should be switched off (1→0). When the servo motor reaches the first zero mark, it starts to travel towards the reference point defined in p2600 with the speed specified in p2611. When the servo motor reaches the reference point (p2599), the signal REFOK is output. Switch off the signal SREF (1→0) and the referencing finishes successfully.

The whole process is shown in the diagram below:

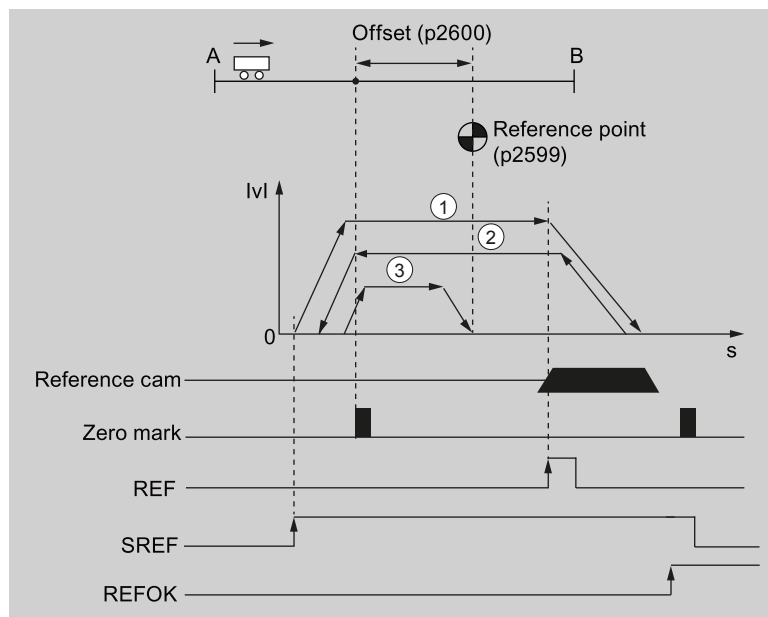

- ① Speed for searching the cam (p2605)
- ↓
- ② Speed for searching zero mark (p2608)
- ↓
- ③ Speed for searching reference point (p2611)

Follow the steps below to perform referencing with this mode:

1. Set relevant parameters:

| Parameter | Range | Factory setting | Unit | Description |
|-----------|---------------------------|-----------------|-------------|---|
| p2599 | 0 to 1000 | 0 | ms | Smooths parameter in response to a sudden position setpoint |
| p2600 | -2147482648 to 2147482647 | 0 | LU | Reference point offset |
| p2604 | 0 to 1 | 0 | - | Sets signal source for start direction of searching cam: <ul style="list-style-type: none"> • 0: start in positive direction • 1: start in negative direction |
| p2605 | 1 to 40000000 | 5000 | 1000 LU/min | Speed for searching the cam |
| p2606 | 0 to 2147482647 | 2147482647 | LU | Maximum distance for searching the cam |
| p2608 | 1 to 40000000 | 300 | 1000 LU/min | Speed for searching zero mark |
| p2609 | 0 to 2147482647 | 20000 | LU | Maximum distance for searching the zero mark |
| p2611 | 1 to 40000000 | 300 | 1000 LU/min | Speed for searching reference point |

2. Configure signals SREF and REF.

Refer to Chapter "Digital inputs/outputs (DIs/DOs) (Page 60)" for reference.

3. Trigger SREF to a rising edge to start referencing.

Note

During the referencing, if SREF is OFF, the referencing stops.

4. If the servo motor reaches the reference point, the signal REFOK (if configured) is output.
5. Switch off the signal SREF, and the referencing finishes successfully.

Encoder zero mark only (p29240=2)

In this mode, there is no cam available. The referencing is triggered by signal SREF. After that, the servo motor accelerates to the speed specified in p2608 and the direction (CW or CCW) is defined by p2604. When the servo motor reaches the first zero mark, it starts to travel towards the reference point defined in p2600 with the speed specified by p2611. When the servo motor reaches the reference point (p2599), the signal REFOK is output. Switch off the signal SREF (1→0) and the referencing finishes successfully.

The whole process is shown in the diagram below:

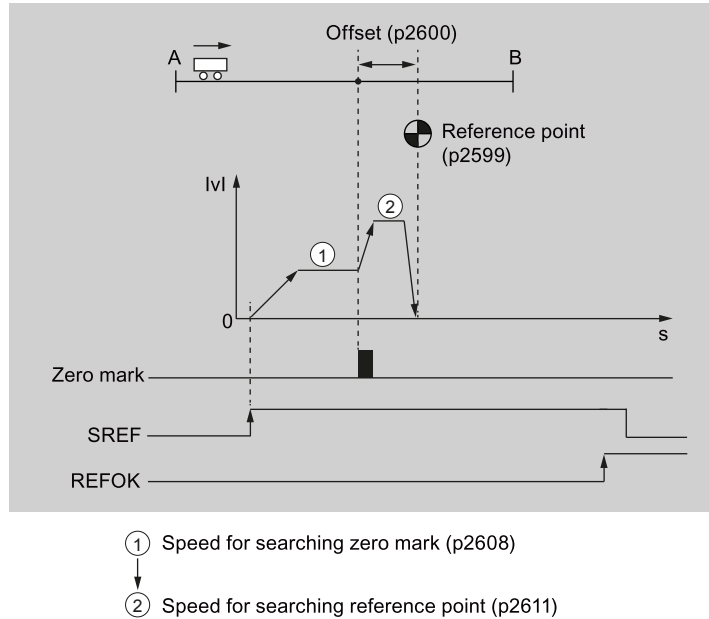

Follow the steps below to perform referencing with this mode:

1. Set relevant parameters:

| Parameter | Range | Factory setting | Unit | Description |
|-----------|---------------------------|-----------------|-------------|---|
| p2599 | 0 to 1000 | 0 | ms | Smooths parameter in response to a sudden position setpoint |
| p2600 | -2147482648 to 2147482647 | 0 | LU | Reference point offset |
| p2604 | 0 to 1 | 0 | - | Sets signal source for start direction of searching cam: <ul style="list-style-type: none"> 0: start in positive direction 1: start in negative direction |
| p2608 | 1 to 40000000 | 300 | 1000 LU/min | Speed for searching zero mark |
| p2609 | 0 to 2147482647 | 20000 | LU | Maximum distance for searching the zero mark |
| p2611 | 1 to 40000000 | 300 | 1000 LU/min | Speed for searching reference point |

2. Configure the signal SREF.

3. Trigger SREF to a rising edge to start referencing.

Note

During the referencing, if SREF is OFF, the referencing stops.

4. If the servo motor reaches the reference point, the signal REFOK (if configured) is output.
5. Switch off the signal SREF, and the referencing finishes successfully.

External reference cam (signal CCWL) and encoder zero mark (p29240=3)

The referencing is triggered by signal SREF. After that, the servo motor accelerates to the speed specified in p2605 to find the reference cam. The direction (CCW) for searching the reference cam is defined by p2604. When the signal CCWL is detected, the servo motor decelerates to standstill with maximum deceleration. Then the servo motor accelerates again to the speed specified in p2608 and the running direction (CW) is opposite to the direction defined by p2604. When the servo motor finds the first zero mark, it starts to travel towards the reference point defined in p2600 with the speed specified in p2611. When the servo motor reaches the reference point (p2599), the signal REFOK is output. Switch off the signal SREF (1→0) and the referencing finishes successfully.

The whole process is shown in the diagram below:

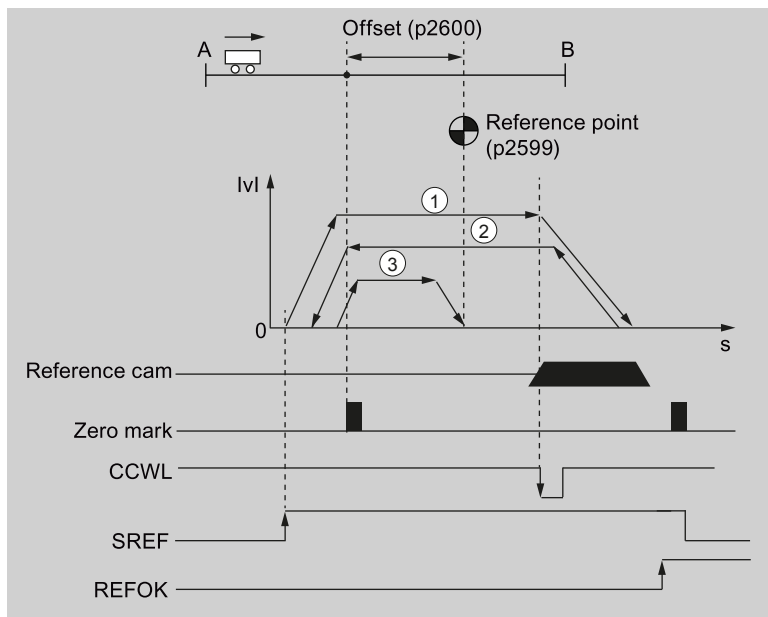

- ① Speed for searching the cam (p2605)
- ↓
- ② Speed for searching zero mark (p2608)
- ↓
- ③ Speed for searching reference point (p2611)

Note

- Once the referencing process is complete, the signal CCWL will act as limits signal again.
- For the safety purpose, the maximum distance for searching the cam (p2606) and the maximum distance for searching the zero mark (p2609) **must** be set.

Follow the steps below to perform referencing with this mode:

1. Set relevant parameters:

| Parameter | Range | Factory setting | Unit | Description |
|---------------------|---------------------------|-----------------|-------------|--|
| p2599 | 0 to 1000 | 0 | ms | Smooths parameter in response to a sudden position setpoint. |
| p2600 | -2147482648 to 2147482647 | 0 | LU | Reference point offset |
| p2604 ¹⁾ | 0 to 1 | 0 | - | Sets signal source for start direction of searching cam: <ul style="list-style-type: none"> • 0: start in positive direction (CW) • 1: start in negative direction (CCW) |
| p2605 | 1 to 40000000 | 5000 | 1000 LU/min | Speed for searching the cam |
| p2606 | 0 to 2147482647 | 2147482647 | LU | Maximum distance for searching the cam |
| p2608 | 1 to 40000000 | 300 | 1000 LU/min | Speed for searching zero mark |
| p2609 | 0 to 2147482647 | 20000 | LU | Maximum distance for searching the zero mark |
| p2611 | 1 to 40000000 | 300 | 1000 LU/min | Speed for searching reference point |

¹⁾ When p29240= 3, the direction for searching the reference cam must be CCW, that is p2604=1.

2. Configure the signal SREF and CCWL.
3. Trigger SREF to a rising edge to start referencing.

Note

During the referencing, if SREF is OFF, the referencing stops.

4. If the servo motor reaches the reference point, the signal REFOK (if configured) is output.
5. Switch off the signal SREF, and the referencing finishes successfully.

External reference cam (signal CWL) and encoder zero mark (p29240=4)

The referencing is triggered by signal SREF. After that, the servo motor accelerates to the speed specified in p2605 to find the reference cam. The direction (CW) for searching the reference cam is defined by p2604. When the signal CWL is detected, the servo motor decelerates to standstill with maximum deceleration. Then the servo motor accelerates again to the speed specified in p2608 and the running direction (CCW) is opposite to the direction defined by p2604. When the servo motor finds the first zero mark, it starts to travel towards the reference point defined in p2600 with the speed specified in p2611. When the servo motor reaches the reference point (p2599), the signal REFOK is output. Switch off the signal SREF (1→0) and the referencing finishes successfully.

The whole process is shown in the diagram below:

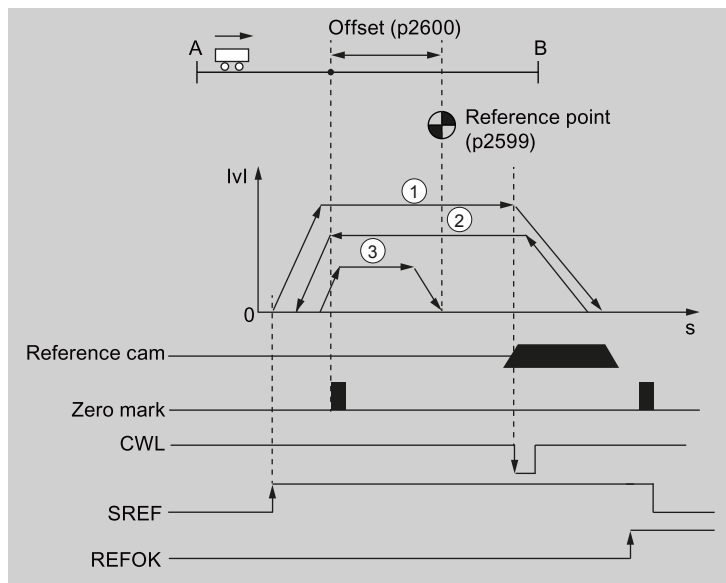

- ① Speed for searching the cam (p2605)
- ↓
- ② Speed for searching zero mark (p2608)
- ↓
- ③ Speed for searching reference point (p2611)

Note

- Once the referencing process is complete, the signal CWL will act as limits signal again.
- For the safety purpose, the maximum distance for searching the cam (p2606) and the maximum distance for searching the zero mark (p2609) **must** be set.

Follow the steps below to perform referencing with this mode:

1. Set relevant parameters:

| Parameter | Range | Factory setting | Unit | Description |
|---------------------|---------------------------|-----------------|-------------|---|
| p2599 | 0 to 1000 | 0 | ms | Smooths parameter in response to a sudden position setpoint. |
| p2600 | -2147482648 to 2147482647 | 0 | LU | Reference point offset |
| p2604 ¹⁾ | 0 to 1 | 0 | - | Sets signal source for start direction of searching cam: <ul style="list-style-type: none"> • 0: start in positive direction • 1: start in negative direction |
| p2605 | 1 to 40000000 | 5000 | 1000 LU/min | Speed for searching the cam |
| p2606 | 0 to 2147482647 | 2147482647 | LU | Maximum distance for searching the cam |
| p2608 | 1 to 40000000 | 300 | 1000 LU/min | Speed for searching zero mark |
| p2609 | 0 to 2147482647 | 20000 | LU | Maximum distance for searching the zero mark |
| p2611 | 1 to 40000000 | 300 | 1000 LU/min | Speed for searching reference point |

¹⁾ When p29240= 4, the direction for searching the reference cam must be CW, that is p2604=0.

2. Configure the signal SREF and CWL.
3. Trigger SREF to a rising edge to start referencing.

Note

During the referencing, if SREF is OFF, the referencing stops.

4. If the servo motor reaches the reference point, the signal REFOK (if configured) is output.
5. Switch off the signal SREF, and the referencing finishes successfully.

7.4.7 Software position limit

The following two software position limits are available in the internal position control mode:

- positive position limit
- negative position limit

The function of software position limit only becomes active after going to reference. When the actual position reaches one of the above-mentioned software position limits, motor speed decelerates to 0.

Parameter settings

| Parameter | Range | Factory setting | Unit | Description |
|-----------|---------------------------|-----------------|------|---|
| p2580 | -2147482648 to 2147482647 | -2147482648 | LU | Negative software position limit switch |
| p2581 | -2147482648 to 2147482647 | 2147482648 | LU | Positive software position limit switch |
| p2582 | 0 to 1 | 0 | - | Activation of software limit switch: <ul style="list-style-type: none"> • 0: deactivate • 1: activate |

7.4.8 Speed limit

Refer to "Speed limit (Page 142)" for details.

7.4.9 Torque limit

Refer to "Torque limit (Page 143)" for details.

7.4.10 Selecting a fixed position setpoint and starting positioning

In the IPos mode, two methods are available to select a fixed position setpoint and then start motor running according to selected fixed position setpoint:

- select a fixed position setpoint with the co-settings of signals POS1, POS2 and POS3 and then use the trigger signal P-TRG to start positioning
- use the rising edge of the signal STEPF, STEPB or STEPH

Refer to Chapter "Digital inputs/outputs (DIs/DOs) (Page 60)" for detailed information about the signals POS1, POS2, POS3, P-TRG, STEPF, STEPB, STEPH.

Selecting the target position with the signals POS1, POS2 and POS3, and starting the positioning with the trigger signal P-TRG

Select one of the eight fixed position setpoints with the co-settings of signals POS1, POS2 and POS3:

| Fixed position setpoint | Signal | | |
|---------------------------|--------|------|------|
| | POS3 | POS2 | POS1 |
| Fixed position setpoint 1 | 0 | 0 | 0 |
| Fixed position setpoint 2 | 0 | 0 | 1 |
| Fixed position setpoint 3 | 0 | 1 | 0 |
| Fixed position setpoint 4 | 0 | 1 | 1 |

| Fixed position setpoint | Signal | | |
|---------------------------|--------|------|------|
| | POS3 | POS2 | POS1 |
| Fixed position setpoint 5 | 1 | 0 | 0 |
| Fixed position setpoint 6 | 1 | 0 | 1 |
| Fixed position setpoint 7 | 1 | 1 | 0 |
| Fixed position setpoint 8 | 1 | 1 | 1 |

In the fixed position control mode, the signals POS1 and POS2 are default assignments of DI7 and DI8 while the signal POS3 is not assigned:

| Signal type | Signal name | Pin assignment | Description |
|-------------|-------------|----------------|-----------------------------------|
| DI | POS1 | X8-11 | Select a fixed position setpoint. |
| DI | POS2 | X8-12 | |
| DI | POS3 | To be assigned | |

Note

Configuration of POS3

If the POS3 is not assigned to any DI, its status is assumed to be 0, which means only the following fixed position setpoints can be used:

- Fixed position setpoint 1
- Fixed position setpoint 2
- Fixed position setpoint 3
- Fixed position setpoint 4

After selecting a fixed position setpoint, the servo motor can start positioning at a rising edge of the signal P-TRG.

The digital input signal P-TRG is the default assignment of DI6 in the internal position control mode:

| Signal type | Signal name | Pin assignment | Setting | Description |
|-------------|-------------|----------------|---------|--|
| DI | P-TRG | X8-10 | 0→1 | Starts positioning according to selected fixed position setpoint |

The timing diagram for starting positioning with the trigger signal P-TRG is shown as follows:

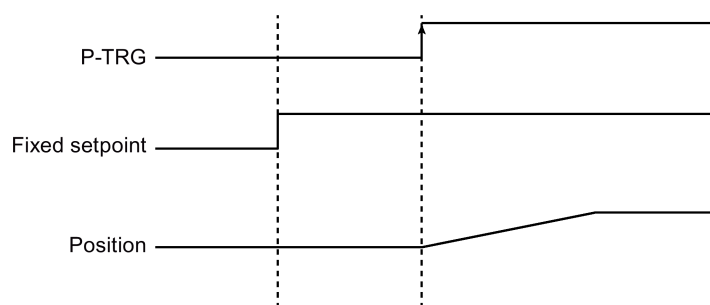

Selecting the target position and starting the positioning with the rising edge of the signal STEPF, STEPB or STEPH

If the signal STEPF is used, the servo motor, at a rising edge of STEPF, traverses to next fixed position setpoint. For example, if the servo motor currently locates at the fixed position setpoint 3, the servo motor traverses to the fixed position setpoint 4 at a rising edge of STEPF.

If the signal STEPB is used, the servo motor, at a rising edge of STEPB, traverses to previous fixed position setpoint.

If the signal STEPH is used, the servo motor, at a rising edge of STEPH, traverses to the fixed position setpoint 1.

Note

The servo drive can respond to the rising edge of the signal STEPF, STEPB or STEPH **only** when the servo motor is at a standstill.

If the servo motor is at fixed position 8, a rising edge of STEPF is not responded.

If motor is at fixed position 1, a rising edge of STEPH is responded, but a rising edge of STEPB is not responded.

7.5 Speed control (S)

7.5.1 Configuring speed setpoint

Eight sources in total are available for speed setpoint. You can select one of them with the combination of digital input signals SPD1, SPD2 and SPD3:

| Digital signal | | | Torque limit |
|----------------|------|------|---|
| SPD3 | SPD2 | SPD1 | |
| 0 | 0 | 0 | External analog speed setpoint (analog input 1) |
| 0 | 0 | 1 | Fixed speed setpoint 1 (p1001) |
| 0 | 1 | 0 | Fixed speed setpoint 2 (p1002) |
| 0 | 1 | 1 | Fixed speed setpoint 3 (p1003) |
| 1 | 0 | 0 | Fixed speed setpoint 4 (p1004) |
| 1 | 0 | 1 | Fixed speed setpoint 5 (p1005) |
| 1 | 1 | 0 | Fixed speed setpoint 6 (p1006) |
| 1 | 1 | 1 | Fixed speed setpoint 7 (p1007) |

Refer to "DIs (Page 61)" for more information about the digital signals SPD1, SPD2 and SPD3.

7.5.1.1 Speed control with external analog speed setpoint

In the S mode, when the digital input signals SPD1, SPD2 and SPD3 are all at low level (0), analog voltage from the analog input 1 is used as the speed setpoint.

The analog voltage from the analog input 1 corresponds to a parameterized speed value. Default speed value is rated motor speed. The analog voltage of 10 V corresponds to the maximum speed setpoint (V_{max}) and this maximum speed setpoint can be specified by parameter p29060.

| Parameter | Range | Factory setting | Unit | Description |
|-----------|-------------|-----------------|------|---|
| p29060 | 6 to 210000 | 3000 | rpm | Maximum analog speed setpoint corresponding to 10 V |

The relationship between the analog voltage and the speed setpoint is shown as follows:

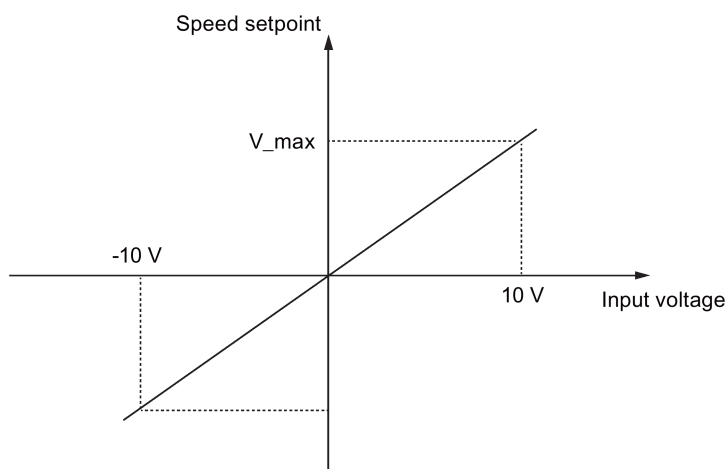

Offset adjustment for analog input 1

Offset exists for the input voltage from the analog input 1. You have two methods to adjust such offset:

- Automatic adjustment with BOP function: refer to "Adjusting AI offsets (Page 124)" for details.
- Manual input of an offset value (p29061)

| Parameter | Range | Factory setting | Unit | Description |
|-----------|---------------|-----------------|------|---|
| p29061 | -0.50 to 0.50 | 0 | V | Offset adjustment for analog input 1 (speed setpoint) |

7.5 Speed control (S)

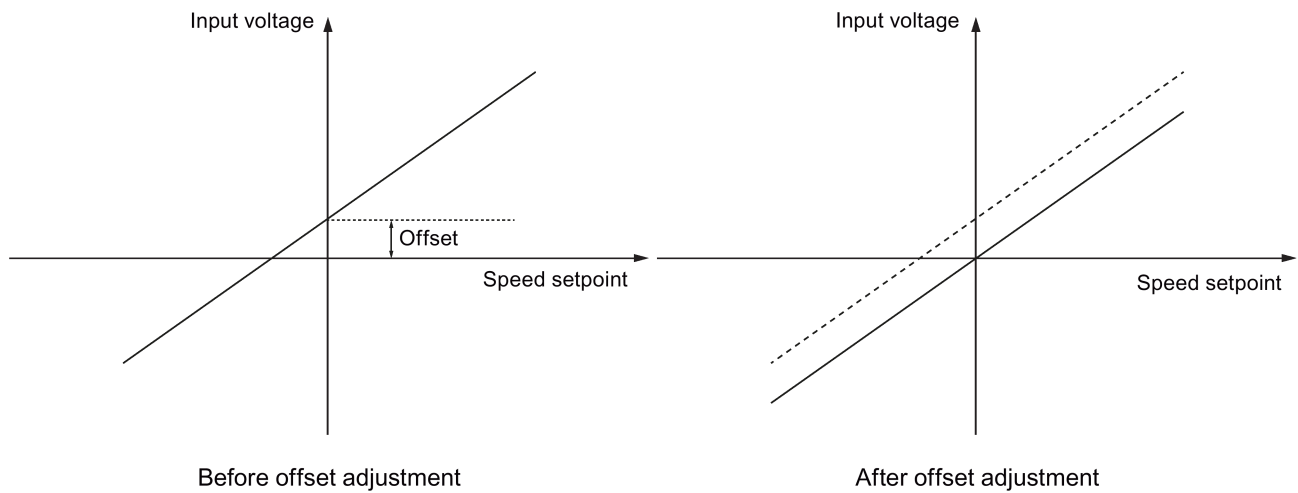

7.5.1.2 Speed control with fixed speed setpoint

Parameter settings

In the S mode, when at least one of the three digital input signals SPD1, SPD2 and SPD3 is at high level, one of the following parameter values is used as speed setpoint:

| Parameter | Value range | Default | Unit | Description | Digital input | | |
|-----------|-------------------|---------|------|------------------------|---------------|------|------|
| | | | | | SPD3 | SPD2 | SPD1 |
| p1001 | -210000 to 210000 | 0 | rpm | Fixed speed setpoint 1 | 0 | 0 | 1 |
| p1002 | -210000 to 210000 | 0 | rpm | Fixed speed setpoint 2 | 0 | 1 | 0 |
| p1003 | -210000 to 210000 | 0 | rpm | Fixed speed setpoint 3 | 0 | 1 | 1 |
| p1004 | -210000 to 210000 | 0 | rpm | Fixed speed setpoint 4 | 1 | 0 | 0 |
| p1005 | -210000 to 210000 | 0 | rpm | Fixed speed setpoint 5 | 1 | 0 | 1 |
| p1006 | -210000 to 210000 | 0 | rpm | Fixed speed setpoint 6 | 1 | 1 | 0 |
| p1007 | -210000 to 210000 | 0 | rpm | Fixed speed setpoint 7 | 1 | 1 | 1 |

7.5.2 Direction and stop

Two digital input signals are used to control motor direction and run/stop.

- CWE: clockwise enable
- CCWE: counter-clockwise enable

The following table shows you in details:

| Signal | | Fixed speed setpoint | Analog speed setpoint | | |
|--------|-----|----------------------|-----------------------|------------|------|
| CCWE | CWE | | + polarity | - polarity | 0 V |
| 0 | 0 | Stop | Stop | Stop | Stop |
| 0 | 1 | CW | CW | CCW | Stop |
| 1 | 0 | CCW | CCW | CW | Stop |
| 1 | 1 | Stop | Stop | Stop | Stop |

Note

For more information about signals CWE and CCWE, refer to "DIs (Page 61)".

7.5.3 Speed limit

Refer to "Speed limit (Page 142)" for details.

7.5.4 Torque limit

Refer to "Torque limit (Page 143)" for details.

7.5.5 Zero speed clamp

The function of zero speed clamp is used to stop motor and lock motor axis when motor speed setpoint is below a parameterized threshold level (p29075).

This function is available only when the analog input 1 is used as the source of speed setpoint. The digital input signal ZSCLAMP is used to activate this function. When both motor speed setpoint and motor actual speed are below the parameterized threshold level and signal ZSCLAMP is logic "1", the motor is locked. Drive exits from clamping state either when the motor speed setpoint is above the threshold level or when the signal ZSCLAMP is logic "0".

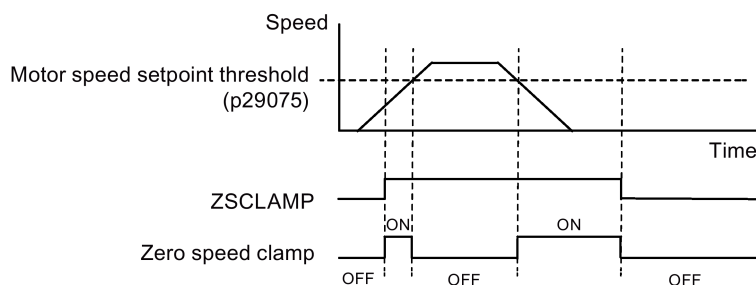

Parameter settings

| Parameter | Value range | Default | Unit | Description |
|-----------|-------------|---------|------|---|
| p29075 | 0 to 200 | 200 | rpm | Zero speed clamp threshold |
| p29060 | 6 to 210000 | 3000 | % | Maximum analog speed setpoint corresponding to 10 V |

DI configuration

| Signal type | Signal name | Pin assignment | Setting | Description |
|-------------|-------------|----------------|---------|---|
| DI | ZSCLAMP | To be assigned | 1 | When the motor speed setpoint is below zero speed clamp threshold, the motor is locked. |
| | | | 0 | No action |

Note

When p29003=4 and CMODE is "1", the drive is working in speed control mode. In this case if ZSCLAMP is activated, the drive will switch to PTI control mode and PTI pulse input will lead motor running under PTI control mode.

Note

For more information about the signal ZSCLAMP, refer to "DIs (Page 61)".

7.5.6 Ramp-function generator

The ramp-function generator is used to limit acceleration in the event of abrupt setpoint changes and thus helps prevent load surges during drive operation.

The ramp-up time p1120 and ramp-down time p1121 can be used to set acceleration and deceleration ramps separately. This allows a smoothed transition in the event of setpoint changes.

The maximum speed p1082 is used as the reference value for calculating the ramp-up and ramp-down times.

You can see the properties of the ramp-function generator from the diagram below:

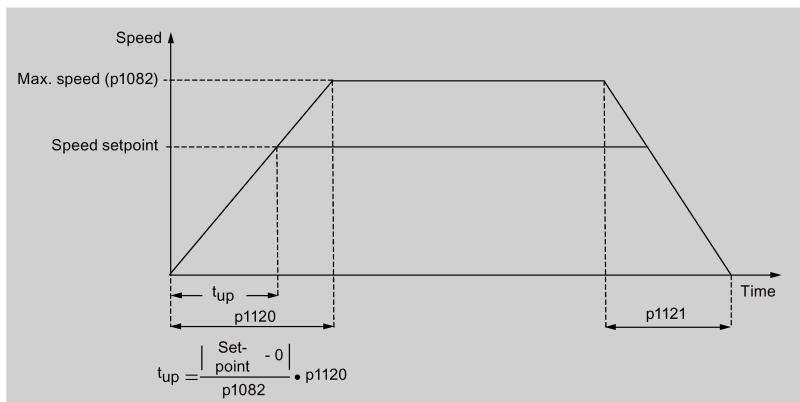

S-curve ramp-function generator

You can also use the S-curve ramp-function generator by setting p1115 to 1. The S-curve ramp-function generator is realized with:

- the acceleration (p1120) and deceleration (p1121) ramps
- the initial (p1130) and final (p1131) rounding-off times

You can see the properties of the S-curve ramp-function generator from the diagram below:

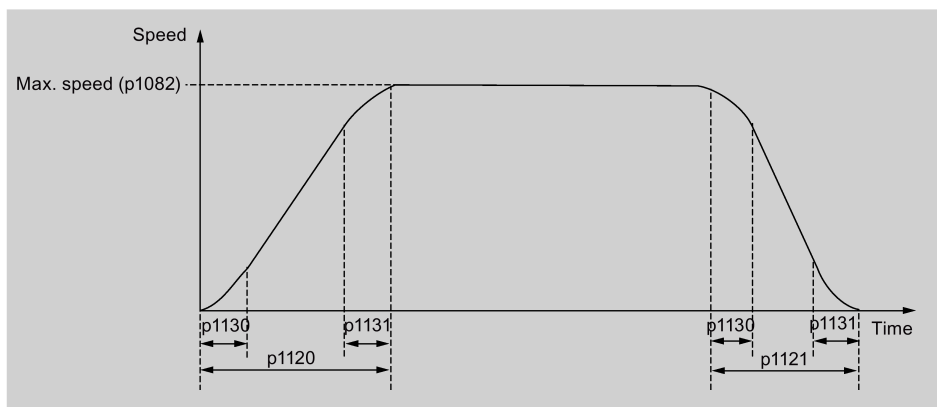

Parameter settings

| Parameter | Value range | Default | Unit | Description |
|-----------|-------------|---------|------|---|
| p1082 | 0 to 210000 | 1500 | rpm | Maximum motor speed |
| p1115 | 0 to 1 | 0 | - | Ramp-function generator selection |
| p1120 | 0 to 999999 | 1 | s | Ramp-function generator ramp-up time |
| p1121 | 0 to 999999 | 1 | s | Ramp-function generator ramp-down time |
| p1130 | 0 to 30 | 0 | s | Ramp-function generator initial rounding-off time |
| p1131 | 0 to 30 | 0 | s | Ramp-function generator final rounding-off time |

7.6 Torque control (T)

7.6.1 300% overload capacity

SINAMICS V90 servo drives can work with 300% overload capacity for a specific time period. The following diagrams show in details:

- Without load

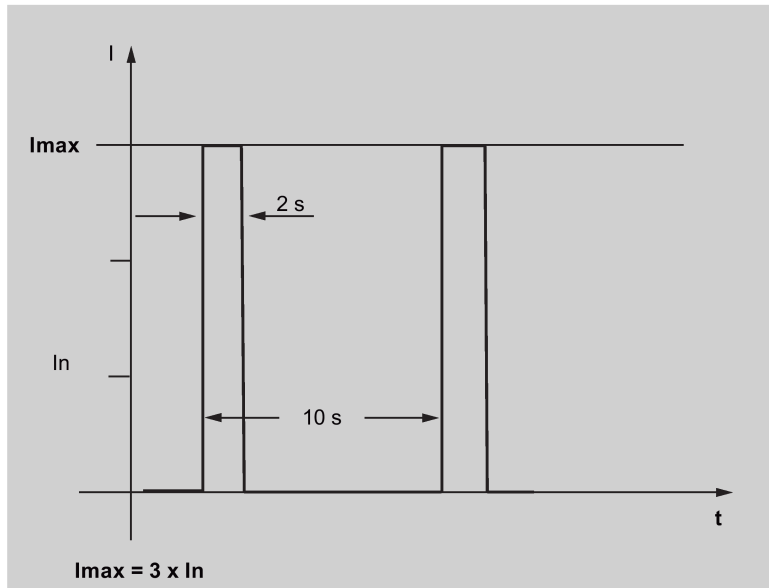

- With load

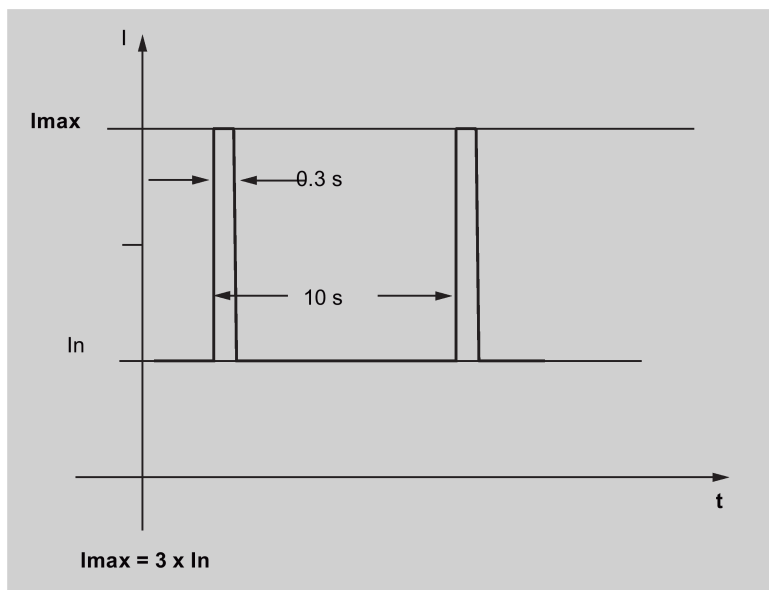

7.6.2 Torque setpoint

Two sources are available for torque setpoint:

- External setpoint: analog input 2
- Fixed setpoint: p29043

These two resources can be selected with the digital input signal TSET:

| Signal | Level | Source of torque setpoint |
|--------|-------------|---|
| TSET | 0 (default) | Analog torque setpoint (analog input 2) |
| | 1 | Fixed torque setpoint (p29043) |

Refer to "DIs (Page 61)" for detailed information about the signal TSET.

7.6.2.1 Torque control with external analog torque setpoint

In the T mode, when the digital input signal TSET is at low level, analog voltage from the analog input 2 is used as the torque setpoint.

The analog voltage from the analog input 2 corresponds to a parameterized torque value scaling (p29041[0]). If p29041[0] = 100%, analog input voltage of 10 V corresponds to rated torque; if p29041[0] = 50%, the analog input value of 10 V corresponds to 50% of the rated torque.

| Parameter | Range | Factory setting | Unit | Description |
|-----------|----------|-----------------|------|--|
| p29041[0] | 0 to 100 | 100 | % | Scaling for analog torque setpoint (corresponding to 10 V) |

Note

The value of analog input 2 can be monitored through parameter r0755.

Offset adjustment for analog input 2

Offset exists for the input voltage from the analog input 2. The motor can run at a very low speed even the current input voltage is 0 V. You have 2 methods to adjust such offset:

- Automatic adjustment with BOP function: refer to "Adjusting AI offsets (Page 124)" for details.
- Manual input of an offset value (p29042)

| Parameter | Range | Factory setting | Unit | Description |
|-----------|---------------|-----------------|------|--|
| p29042 | -0.50 to 0.50 | 0 | V | Offset adjustment for analog input 2 (torque setpoint) |

7.6 Torque control (T)

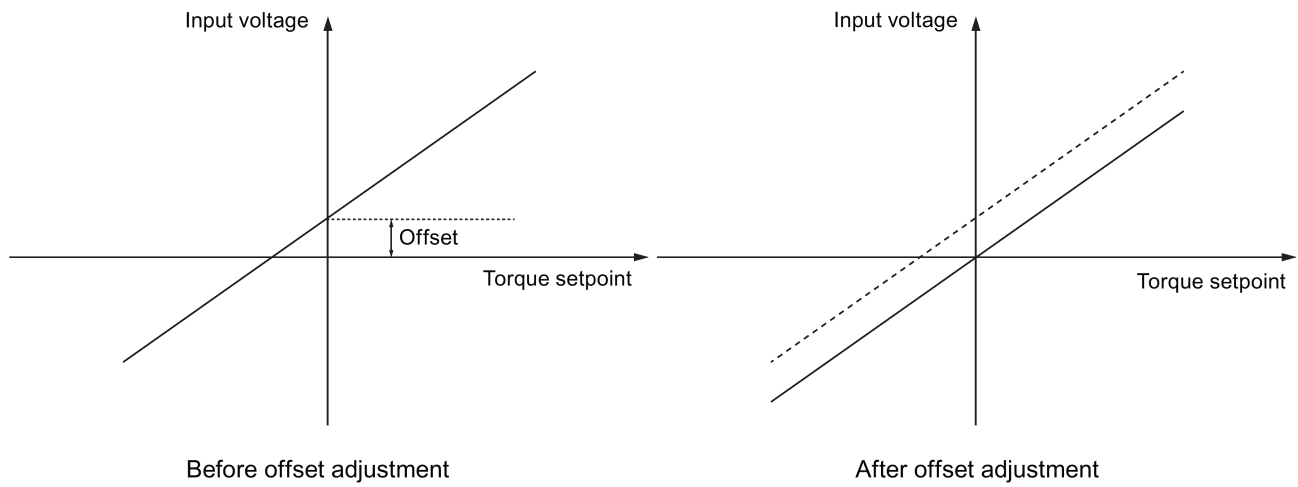

7.6.2.2 Torque control with fixed torque setpoint

Parameter settings

| Parameter | Range | Factory setting | Unit | Description |
|-----------|-------------|-----------------|------|-----------------------|
| p29043 | -100 to 100 | 0 | % | Fixed torque setpoint |

7.6.3 Direction and stop

Two digital input signals are used to control motor direction and run/stop:

- CWE: clockwise enable
- CCWE: counter-clockwise enable

The following table shows you in details:

| Signal | | Fixed torque setpoint | Analog torque setpoint | | |
|--------|-----|-----------------------|------------------------|------------|-----|
| CCWE | CWE | | + polarity | - polarity | 0 V |
| 0 | 0 | 0 | 0 | 0 | 0 |
| 0 | 1 | CW | CW | CCW | 0 |
| 1 | 0 | CCW | CCW | CW | 0 |
| 1 | 1 | 0 | 0 | 0 | 0 |

Note

For more information about the signals CWE and CCWE, refer to "DIs (Page 61)".

7.6.4 Speed limit

Refer to "Speed limit (Page 142)" for details.

7.7 Absolute position system

When the SINAMICS V90 servo drive uses a servo motor with an absolute encoder, the current absolute position can be detected and transmitted to the controller. With this function of absolute position system, you can perform motion control task immediately after the servo system is powered on, which means you do not have to carry out referencing or zero position operation beforehand.

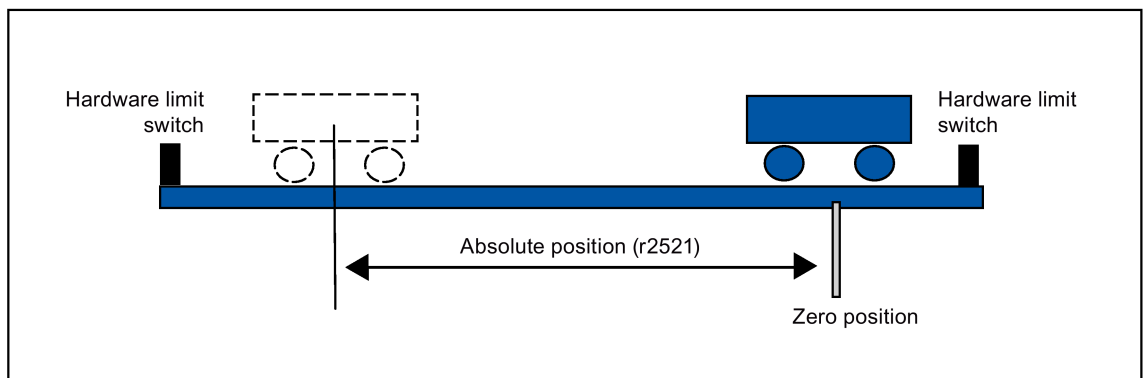

Restrictions

The absolute position system **cannot** be configured under the following conditions:

- Internal position control (IPos)
- Speed control (S)
- Torque control (T)
- Control change mode
- Strokeless coordinate system, for example, rotary shaft, infinitely long positioning operation
- Change of electronic gear after referencing
- Use of alarm code output

7.7.1 USS communication telegram

As mentioned before, the SINAMICS V90 servo drive communicates with the PLC through an RS485 cable and the standard USS communication protocol is used.

Telegram format

The telegram format is shown as follows:

| | | | | | | | |
|-----|-----|-----|-----|-----|-----|-----|-----|
| STX | LGE | ADR | PKE | IND | PWE | PWE | BCC |
|-----|-----|-----|-----|-----|-----|-----|-----|

STX: start of text

LGE: length

ADR: slave address

PKE: parameter ID

IND: sub-index

PWE: parameter value

BCC: block check character

7.7.2 Transmitting sequence for the absolute position data

The following table shows you the transmitting sequence for the absolute position data:

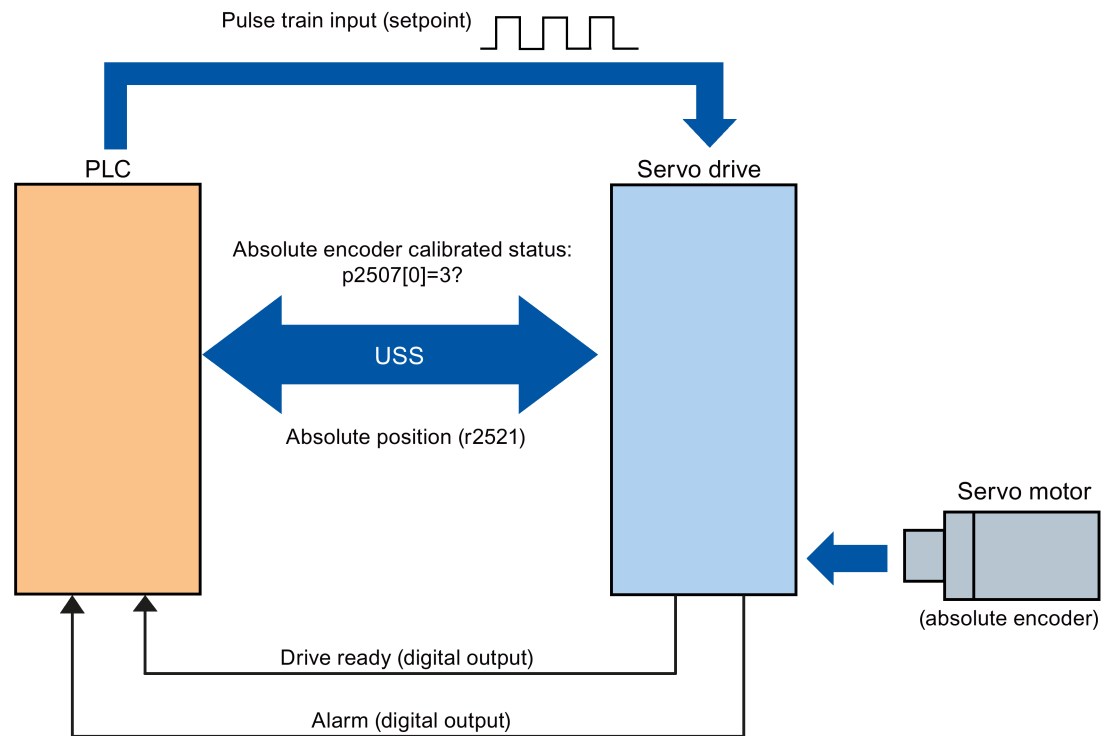

| Main step | | Sub step/comment |
|-----------|--|---|
| ① | Set PTI control mode. | Set p29003 = 0. |
| ② | Enable absolute position mode. | Set p29250 = 1. |
| ③ | Configure relative parameters. | <ol style="list-style-type: none"> 1. Set PTI input parameters (p29010 to p29014). 2. Set position control parameters (p29247 to p29249). 3. Set electrical gear p29012 and p29013. |
| ④ | Referencing with the BOP or SINAMICS V-ASSISTANT. NOTE: You must perform the referencing operation under the following conditions: <ul style="list-style-type: none"> • System setup is performed. • The servo drive has been changed. • The servo motor has been changed. • An alarm occurs. | <ol style="list-style-type: none"> 1. Run the servo motor for a proper distance. 2. Adjust the absolute encoder with the BOP menu function "ABS" or SINAMICS V-ASSISTANT. |
| ⑤ | Configure the parameters for the USS communication. | <ol style="list-style-type: none"> 1. Set RS485 address (p29004). 2. Set baud rate (38400 bps). |
| ⑥ | Start transmitting. | |
| ⑦ | Transmit the calibration status of the absolute encoder to the PLC. | <ol style="list-style-type: none"> 1. Turn on the servo-on enable signal (SON). 2. The PLC checks the standstill status and alarm status through the digital output of the servo drive. 3. If there is no alarm and the motor is in standstill status, the PLC sends a data request to the servo drive through the RS485 cable. 4. In response to the data request from PLC, the servo drive transmits calibration status (p2507[0]=3) of encoder to the PLC. |
| ⑧ | Transmit the absolute position data to the PLC. | <ol style="list-style-type: none"> 1. If the absolute encoder is calibrated, and meanwhile, the servo drive is ready (the digital output RDY is logic 1) and in standstill status (the digital output signal INP is logic 1), the PLC sends a data request to drive through the RS485 cable. 2. In response to the data request from the PLC, the servo drive transmits the absolute position data (r2521) to the PLC. |

Safety Integrated function

8.1 Standards and regulations

8.1.1 General information

8.1.1.1 Aims

Manufacturers and operating companies of equipment, machines, and products are responsible for ensuring the required level of safety. This means that plants, machines, and other equipment must be designed to be as safe as possible in accordance with the current state of the art. To ensure this, companies describe in the various standards the current state of the art covering all aspects relevant to safety. When the relevant Standards are observed, this ensures that state-of-the-art technology has been utilized and, in turn, the erector/builder of a plant or a manufacturer of a machine or a piece of equipment has fulfilled his appropriate responsibility.

Safety systems are designed to minimize potential hazards for both people and the environment by means of suitable technical equipment, without restricting industrial production and the use of machines more than is necessary. The protection of man and environment must be assigned equal importance in all countries, which is it is important that rules and regulations that have been internationally harmonized are applied. This is also designed to avoid distortions in the competition due to different safety requirements in different countries.

There are different concepts and requirements in the various regions and countries of the world when it comes to ensuring the appropriate degree of safety. The legislation and the requirements of how and when proof is to be given and whether there is an adequate level of safety are just as different as the assignment of responsibilities.

The most important thing for manufacturers of machines and companies that set up plants and systems is that the legislation and regulations in the country where the machine or plant is being operated apply. For example, the control system for a machine that is to be used in the US must fulfill local US requirements even if the machine manufacturer (OEM) is based in the European Economic Area (EEA).

8.1.1.2 Functional safety

Safety, from the perspective of the object to be protected, cannot be split-up. The causes of hazards and, in turn, the technical measures to avoid them can vary significantly. This is why a differentiation is made between different types of safety (e.g. by specifying the cause of possible hazards). "Functional safety" is involved if safety depends on the correct function. To ensure the functional safety of a machine or plant, the safety-related parts of the protection and control devices must function correctly. In addition, the systems must behave in such a way that either the plant remains in a safe state or it is brought into a safe state if a fault occurs. In this case, it is necessary to use specially qualified technology that fulfills the requirements described in the associated Standards. The requirements to achieve functional safety are based on the following basic goals:

- Avoiding systematic faults
- Controlling systematic faults
- Controlling random faults or failures

Benchmarks for establishing whether or not a sufficient level of functional safety has been achieved include the probability of hazardous failures, the fault tolerance, and the quality that is to be ensured by minimizing systematic faults. This is expressed in the Standards using different terms. In IEC/EN 61508, IEC/EN 62061 "Safety Integrity Level" (SIL) and EN ISO 13849-1 "Categories" and "Performance Level" (PL).

8.1.2 Safety of machinery in Europe

The EU Directives that apply to the implementation of products are based on Article 95 of the EU contract, which regulates the free exchange of goods. These are based on a new global concept ("new approach", "global approach"):

- EU Directives only specify general safety goals and define basic safety requirements.
- Technical details can be defined by means of standards by Standards Associations that have the appropriate mandate from the commission of the European Parliament and Council (CEN, CENELEC). These standards are harmonized in line with a specific directive and listed in the official journal of the commission of the European Parliament and Council. Legislation does not specify that certain standards have to be observed. When the harmonized Standards are observed, it can be assumed that the safety requirements and specifications of the Directives involved have been fulfilled.
- EU Directives specify that the Member States must mutually recognize domestic regulations.

The EU Directives are equal. This means that if several Directives apply for a specific piece of equipment or device, the requirements of all of the relevant Directives apply (e.g. for a machine with electrical equipment, the Machinery Directive and the Low-Voltage Directive apply).

8.1.2.1 Machinery Directive

The basic safety and health requirements specified in Annex I of the Directive must be fulfilled for the safety of machines.

The protective goals must be implemented responsibly to ensure compliance with the Directive.

Manufacturers of a machine must verify that their machine complies with the basic requirements. This verification is facilitated by means of harmonized standards.

8.1.2.2 Harmonized European Standards

The two Standards Organizations CEN (Comité Européen de Normalisation) and CENELEC (Comité Européen de Normalisation Électrotechnique), mandated by the EU Commission, drew-up harmonized European standards in order to precisely specify the requirements of the EC directives for a specific product. These standards (EN standards) are published in the official journal of the commission of the European Parliament and Council and must be included without revision in domestic standards. They are designed to fulfill basic health and safety requirements as well as the protective goals specified in Annex I of the Machinery Directive.

When the harmonized standards are observed, it is "automatically assumed" that the Directive is fulfilled. As such, manufacturers can assume that they have observed the safety aspects of the Directive under the assumption that these are also covered in this standard. However, not every European Standard is harmonized in this sense. Key here is the listing in the official journal of the commission of the European Parliament and Council.

The European Safety of Machines standard is hierarchically structured. It is divided into:

- A standards (basic standards)
- B standards (group standards)
- C standards (product standards)

Type A standards/basic standards

A standards include basic terminology and definitions relating to all types of machine. This includes EN ISO 12100-1 (previously EN 292-1) "Safety of Machines, Basic Terminology, General Design Principles".

A standards are aimed primarily at the bodies responsible for setting the B and C standards. The measures specified here for minimizing risk, however, may also be useful for manufacturers if no applicable C standards have been defined.

Type B standards/group standards

B standards cover all safety-related standards for various different machine types. B standards are aimed primarily at the bodies responsible for setting C standards. They can also be useful for manufacturers during the machine design and construction phases, however, if no applicable C standards have been defined.

A further sub-division has been made for B standards:

- Type B1 standards for higher-level safety aspects (e.g. ergonomic principles, safety clearances from sources of danger, minimum clearances to prevent parts of the body from being crushed).
- Type B2 standards for protective safety devices are defined for different machine types (e.g. EMERGENCY STOP devices, two-hand operating circuits, interlocking elements, contactless protective devices, safety-related parts of controls).

Type C standards/product standards

C standards are product-specific standards (e.g. for machine tools, woodworking machines, elevators, packaging machines, printing machines etc.). Product standards cover machine-specific requirements. The requirements can, under certain circumstances, deviate from the basic and group standards. Type C/product standards have the highest priority for machine manufacturers who can assume that it fulfills the basic requirements of Annex I of the Machinery Directive (automatic presumption of compliance). If no product standard has been defined for a particular machine, type B standards can be applied when the machine is constructed.

A complete list of the standards specified and the mandated draft standards are available on the Internet at the following address:

<http://www.newapproach.org/>

Recommendation: Due to the rapid pace of technical development and the associated changes in machine concepts, the standards (and C standards in particular) should be checked to ensure that they are up to date. Please note that the application of a particular standard may not be mandatory provided that all the safety requirements of the applicable EU directives are fulfilled.

8.1.2.3 Standards for implementing safety-related controllers

If the functional safety of a machine depends on various control functions, the controller must be implemented in such a way that the probability of the safety functions failing is sufficiently minimized. EN ISO 13849-1 (formerly EN 954-1) and EN IEC61508 define principles for implementing safety-related machine controllers which, when properly applied, ensure that all the safety requirements of the EC Machinery Directive are fulfilled. These standards ensure that the relevant safety requirements of the Machinery Directive are fulfilled.

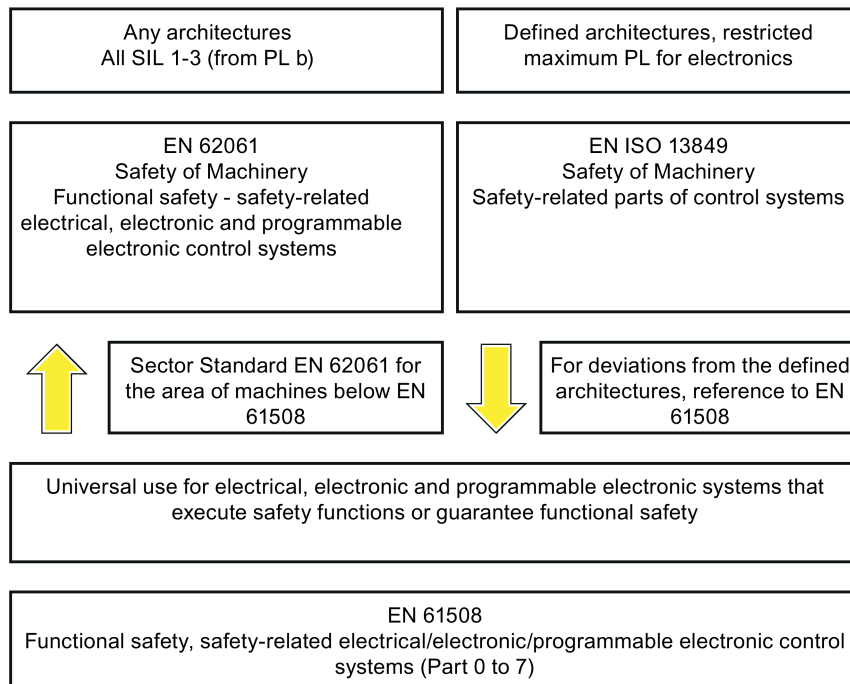

Figure 8-1 Standards for implementing safety-related controllers

The application areas of EN ISO 13849-1, EN 62061, and EN 61508 are very similar. To help users make an appropriate decision, the IEC and ISO associations have specified the application areas of both standards in a joint table in the introduction to the standards. EN ISO 13849-1 or EN 62061 should be applied depending on the technology (mechanics, hydraulics, pneumatics, electrics, electronics and programmable electronics), risk classification and architecture.

| Type | Systems for executing safety-related control functions | EN ISO 13849-1 | EN 62061 |
|------|---|--|--|
| A | Non-electrical (e.g. hydraulic, pneumatic) | X | Not covered |
| B | Electromechanical (e.g. relay and/or basic electronics) | Restricted to the designated architectures (see comment 1) and max. up to PL = e | All architectures and max. up to SIL 3 |
| C | Complex electronics (e.g. programmable electronics) | Restricted to the designated architectures (see comment 1) and max. up to PL = d | All architectures and max. up to SIL 3 |

| Type | Systems for executing safety-related control functions | EN ISO 13849-1 | EN 62061 |
|------|--|--|--|
| D | A standards combined with B standards | Restricted to the designated architectures (see comment 1) and max. up to PL = e | X See comment 3 |
| E | C standards combined with B standards | Restricted to the designated architectures (see comment 1) and max. up to PL = d | All architectures and max. up to SIL 3 |
| F | C standards combined with A standards or C standards combined with A standards and B standards | X See comment 2 | X See comment 3 |

"X" indicates that the point is covered by this standard.

Comment 1:

Designated architectures are described in Annex B of EN ISO 13849-1 and provide a simplified basis for the quantification.

Comment 2:

For complex electronics: Using designated architectures in compliance with EN ISO 13849-1 up to PL = d or every architecture in compliance with EN 62061.

Comment 3:

For non-electrical systems: Use components that comply with EN ISO 13849-1 as sub-systems.

8.1.2.4 DIN EN ISO 13849-1 (replaces EN 954-1)

A qualitative analysis according to DIN EN 13849-1 is not sufficient for modern control systems due to their technology. Among other things, DIN EN ISO 13849-1 does not take into account time behavior (e.g. test interval and/or cyclic test, lifetime). This results in the probabilistic approach in DIN EN ISO 13849-1 (probability of failure per unit time). DIN EN ISO 13849-1 is based on the known categories of EN 954-1. It now also takes into account complete safety functions and all the devices required to execute these. With DIN EN ISO 13849-1, safety functions are investigated from a quantitative perspective going beyond the qualitative basis of EN 954-1. Performance levels (PL), which are based on the categories, are used. The following safety-related characteristic quantities are required for devices/equipment:

- Category (structural requirement)
- PL: Performance level
- MTTF_d: Mean time to dangerous failure
- DC: Diagnostic coverage
- CCF: Common cause failure

The standard describes how the performance level (PL) is calculated for safety-related components of the controller on the basis of designated architectures. In the event of any deviations from this, EN ISO 13849-1 refers to EN 61508.

When combining several safety-related parts to form a complete system, the standard explains how to determine the resulting PL.

Note

DIN EN ISO 13849-1 and machinery directive

Since May 2007, DIN EN ISO 13849-1 has been harmonized as part of the Machinery Directive.

8.1.2.5 EN 62061

EN 62061 (identical to IEC 62061) is a sector-specific standard subordinate to IEC/EN 61508. It describes the implementation of safety-related electrical machine control systems and looks at the complete life cycle, from the conceptual phase to decommissioning. The standard is based on the quantitative and qualitative analyses of safety functions, whereby it systematically applies a top-down approach to implementing complex control systems (known as "functional decomposition"). The safety functions derived from the risk analysis are sub-divided into sub-safety functions, which are then assigned to real devices, sub-systems, and sub-system elements. Both the hardware and software are covered. EN 62061 also describes the requirements placed on implementing application programs.

A safety-related control system comprises different sub-systems. From a safety perspective, the sub-systems are described in terms of the SIL claim limit and PFHD characteristic quantities.

Programmable electronic devices (e.g. PLCs or variable-speed drives) must fulfill EN 61508. They can then be integrated in the controller as sub-systems. The following safety-related characteristic quantities must be specified by the manufacturers of these devices.

Safety-related characteristic quantities for subsystems:

- SIL CL: SIL claim limit
- PFHD: Probability of dangerous failures per hour
- T1: Lifetime

Simple sub-systems (e.g. sensors and actuators) in electromechanical components can, in turn, comprise sub-system elements (devices) interconnected in different ways with the characteristic quantities required for determining the relevant PFHD value of the sub-system.

Safety-related characteristic quantities for subsystem elements (devices):

- λ : Failure rate
- B10 value: For elements that are subject to wear
- T1: Lifetime

For electromechanical devices, a manufacturer specifies a failure rate λ with reference to the number of operating cycles. The failure rate per unit time and the lifetime must be determined using the switching frequency for the particular application.

Parameters for the sub-system, which comprises sub-system elements, that must be defined during the design phase:

- T2: Diagnostic test interval
- β : Susceptibility to common cause failure
- DC: Diagnostic coverage

The PFHD value of the safety-related controller is determined by adding the individual PFHD values for subsystems.

The user has the following options when setting up a safety-related controller:

- Use devices and sub-systems that already comply with EN ISO 13849-1, IEC/EN 61508, or IEC/EN 62061. The standard provides information specifying how qualified devices can be integrated when safety functions are implemented.
- Develop own subsystems:
 - Programmable, electronic systems and complex systems: Application of EN 61508 or EN 61800-5-2.
 - Simple devices and subsystems: Application of EN 62061.

EN 62061 does not include information about non-electric systems. The standard provides detailed information on implementing safety-related electrical, electronic, and programmable electronic control systems. EN ISO 13849-1 must be applied for non-electric systems.

Note

Function examples

Details of simple sub-systems that have been implemented and integrated are now available as "functional examples".

Note

EN 62061 and machinery directive

IEC 62061 has been ratified as EN 62061 in Europe and harmonized as part of the Machinery Directive.

8.1.2.6 Series of standards EN 61508 (VDE 0803)

This series of standards describes the current state of the art.

EN 61508 is not harmonized in line with any EU directives, which means that an automatic presumption of conformity for fulfilling the protective requirements of a directive is not implied. The manufacturer of a safety-related product, however, can also use EN 61508 to fulfill basic requirements of European directives in accordance with the latest conceptual design, for example, in the following cases:

- If no harmonized standard exists for the application in question. In this case, the manufacturer can use EN 61508, although no presumption of conformity exists here.
- A harmonized European standard (e.g. EN 62061, EN ISO 13849, EN 60204-1) references EN 61508. This ensures that the appropriate requirements of the directives are fulfilled ("standard that is also applicable"). When manufacturers apply EN 61508

properly and responsibly in accordance with this reference, they can use the presumption of conformity of the referencing standard.

EN 61508 covers all the aspects that must be taken into account when E/E/PES systems (electrical, electronic, and programmable electronic System) are used in order to execute safety functions and/or to ensure the appropriate level of functional safety. Other hazards (e.g. electric shock) are, as in EN ISO 13849, not part of the standard.

EN 61508 has recently been declared the "International Basic Safety Publication", which makes it a framework for other, sector-specific standards (e.g. EN 62061). As a result, this standard is now accepted worldwide, particularly in North America and in the automotive industry. Today, many regulatory bodies already stipulate it (e.g. as a basis for NRTL listing).

Another recent development with respect to EN 61508 is its system approach, which extends the technical requirements to include the entire safety installation from the sensor to the actuator, the quantification of the probability of hazardous failure due to random hardware failures, and the creation of documentation covering all phases of the safety-related lifecycle of the E/E/PES.

8.1.2.7 Risk analysis/assessment

Risks are intrinsic in machines due to their design and functionality. For this reason, the Machinery Directive requires that a risk assessment be performed for each machine and, if necessary, the level of risk reduced until the residual risk is less than the tolerable risk. To assess these risks, the following standards must be applied:

EN ISO 12100-1 "Safety of Machinery - basic terminology, general principles for design"

EN ISO 13849-1 (successor to EN 954-1) "Safety-related parts of control systems"

EN ISO 12100-1 focuses on the risks to be analyzed and the design principles for minimizing risk.

The risk assessment is a procedure that allows hazards resulting from machines to be systematically investigated. Where necessary, the risk assessment is followed by a risk reduction procedure. When the procedure is repeated, this is known as an iterative process. This can help eliminate hazards (as far as this is possible) and can act as a basis for implementing suitable protective measures.

The risk assessment involves the following:

- Risk analysis
 - Determines the limits of the machine (EN ISO 12100-1)
 - Identification of the hazards (EN ISO 12100-114)
 - Estimating the level of risk (EN 1050 Paragraph 7)
- Risk evaluation

As part of the iterative process to achieve the required level of safety, a risk assessment is carried out after the risk estimation. A decision must be made here as to whether the residual risk needs to be reduced. If the risk is to be further reduced, suitable protective measures must be selected and applied. The risk assessment must then be repeated.

determined in accordance with the risk assessment principle according to ISO 12100 (EN 1050). Annex A of the standard describes a method for determining the required Safety Integrity Level (SIL).

Regardless of which standard is applied, steps must be taken to ensure that all the machine controller components required for executing the safety-related functions fulfill these requirements.

8.1.2.9 Residual risk

In today's technologically advanced world, the concept of safety is relative. The ability to ensure safety to the extent that risk is ruled out in all circumstances – "zero-risk guarantee" – is practically impossible. The residual risk is the risk that remains once all the relevant protective measures have been implemented in accordance with the latest state of the art.

Residual risks must be clearly referred to in the machine/plant documentation (user information according to EN ISO 12100-2).

8.1.3 Machine safety in the USA

A key difference between the USA and Europe in the legal requirements regarding safety at work is that, in the USA, no legislation exists regarding machinery safety that is applicable in all of the states and that defines the responsibility of the manufacturer/supplier. A general requirement exists stating that employers must ensure a safe workplace.

8.1.3.1 Minimum requirements of the OSHA

The Occupational Safety and Health Act (OSHA) from 1970 regulates the requirement that employers must offer a safe place of work. The core requirements of OSHA are specified in Section 5 "Duties".

The requirements of the OSH Act are managed by the "Occupational Safety and Health Administration" (also known as OSHA). OSHA employs regional inspectors who check whether or not workplaces comply with the applicable regulations.

The OSHA regulations are described in OSHA 29 CFR 1910.xxx ("OSHA Regulations (29 CFR) PART 1910 Occupational Safety and Health"). (CFR: Code of Federal Regulations.)

<http://www.osha.gov>

The application of standards is regulated in 29 CFR 1910.5 "Applicability of standards". The concept is similar to that used in Europe. Product-specific standards have priority over general standards insofar as they cover the relevant aspects. Once the standards are fulfilled, employers can assume that they have fulfilled the core requirements of the OSH Act with respect to the aspects covered by the standards.

In conjunction with certain applications, OSHA requires that all electrical equipment and devices that are used to protect workers be authorized by an OSHA-certified, "Nationally Recognized Testing Laboratory" (NRTL) for the specific application.

In addition to the OSHA regulations, the current standards defined by organizations such as NFPA and ANSI must be carefully observed and the extensive product liability legislation that exists in the US taken into account. Due to the product liability legislation, it is in the

8.1 Standards and regulations

interests of manufacturing and operating companies that they carefully maintain the applicable regulations and are "forced" to fulfill the requirement to use state-of-the-art technology.

Third-party insurance companies generally demand that their customers fulfill the applicable standards of the standards organizations. Self-insured companies are not initially subject to this requirement but, in the event of an accident, they must provide verification that they have applied generally-recognized safety principles.

8.1.3.2 NRTL listing

To protect employees, all electrical equipment used in the USA must be certified for the planned application by a "Nationally Recognized Testing Laboratory" (NRTL) certified by the OSHA. NRTLs are authorized to certify equipment and material by means of listing, labeling, or similar. Domestic standards (e.g. NFPA 79) and international standards (e.g. IEC/EN 61508 for E/E/PES systems) are the basis for testing.

8.1.3.3 NFPA 79

Standard NFPA 79 (Electrical Standard for Industrial Machinery) applies to electrical equipment on industrial machines with rated voltages of less than 600 V. A group of machines that operate together in a coordinated fashion is also considered to be one machine.

For programmable electronics and communication buses, NFPA 79 states as a basic requirement that these must be listed if they are to be used to implement and execute safety-related functions. If this requirement is fulfilled, then electronic controls and communication buses can also be used for Emergency Stop functions, Stop Categories 0 and 1 (refer to NFPA 79 9.2.5.4.1.4). Like EN 60204-1, NFPA 79 no longer specifies that the electrical energy must be disconnected by electromechanical means for emergency stop functions.

The core requirements regarding programmable electronics and communication buses are: system requirements (see NFPA 79 9.4.3)

1. Control systems that contain software-based controllers must:

- In the event of a single fault
 - cause the system to switch to a safe shutdown mode
 - prevent the system from restarting until the fault has been rectified
 - prevent an unexpected restart
- Offer the same level of protection as hard-wired controllers
- Be implemented in accordance with a recognized standard that defines the requirements for such systems.

2. IEC 61508, IEC 62061, ISO 13849-1, ISO 13849 2 and IEC 61800-5-2 are specified as suitable standards in a note.

Underwriter Laboratories Inc. (UL) has defined a special category for "Programmable Safety Controllers" for implementing this requirement (code NRGF). This category covers control devices that contain software and are designed for use in safety-related functions.

A precise description of the category and a list of devices that fulfill this requirement can be found on the Internet at the following address:

<http://www.ul.com> → certifications directory → UL Category code/ Guide information → search for category "NRGF"

TUV Rheinland of North America, Inc. is also an NRTL for these applications.

8.1.3.4 ANSI B11

ANSI B11 standards are joint standards developed by associations such as the Association for Manufacturing Technology (AMT) and the Robotic Industries Association (RIA).

The hazards of a machine are evaluated by means of a risk analysis/assessment. The risk analysis is an important requirement in accordance with NFPA 79, ANSI/RIA 15.06, ANSI B11.TR-3 and SEMI S10 (semiconductors). The documented findings of a risk analysis can be used to select a suitable safety system based on the safety class of the application in question.

The situation in Japan is different from that in Europe and the US. Legislation such as that prescribed in Europe does not exist. Similarly, product liability does not play such an important role as it does in the US.

Instead of legal requirements to apply standards have been defined, an administrative recommendation to apply JIS (Japanese Industrial Standard) is in place: Japan bases its approach on the European concept and uses basic standards as national standards (see table).

Table 8- 1 Japanese standards

| ISO/IEC number | JIS number | Comment |
|----------------------|--------------|---|
| ISO12100-1 | JIS B 9700-1 | Earlier designation TR B 0008 |
| ISO12100-2 | JIS B 9700-2 | Earlier designation TR B 0009 |
| ISO14121- 1 / EN1050 | JIS B 9702 | |
| ISO13849- 1 | JIS B 9705-1 | |
| ISO13849- 2 | JIS B 9705-1 | |
| IEC 60204-1 | JIS B 9960-1 | Without annex F or route map of the European foreword |
| IEC 61508-0 to -7 | JIS C 0508 | |
| IEC 62061 | | JIS number not yet assigned |

In addition to the requirements of the guidelines and standards, company-specific requirements must be taken into account. Large corporations in particular (e.g. automobile manufacturers) make stringent demands regarding automation components, which are often listed in their own equipment specifications.

Safety-related issues (e.g. operating modes, operator actions with access to hazardous areas, EMERGENCY STOP concepts, etc.) should be clarified with customers early on so that they can be integrated in the risk assessment/risk reduction process.

8.1.4 Machine safety in Japan

The situation in Japan is different from that in Europe and the US. Legislation such as that prescribed in Europe does not exist. Similarly, product liability does not play such an important role as it does in the US.

Instead of legal requirements to apply standards have been defined, an administrative recommendation to apply JIS (Japanese Industrial Standard) is in place: Japan bases its approach on the European concept and uses basic standards as national standards (see table).

Table 8- 2 Japanese standards

| ISO/IEC number | JIS number | Comment |
|----------------------|--------------|---|
| ISO12100-1 | JIS B 9700-1 | Earlier designation TR B 0008 |
| ISO12100-2 | JIS B 9700-2 | Earlier designation TR B 0009 |
| ISO14121- 1 / EN1050 | JIS B 9702 | |
| ISO13849-1 | JIS B 9705-1 | |
| ISO13849-2 | JIS B 9705-1 | |
| IEC 60204-1 | JIS B 9960-1 | Without annex F or route map of the European foreword |
| IEC 61508-0 to -7 | JIS C 0508 | |
| IEC 62061 | | JIS number not yet assigned |

8.1.5 Equipment regulations

In addition to the requirements of the guidelines and standards, company-specific requirements must be taken into account. Large corporations in particular (e.g. automobile manufacturers) make stringent demands regarding automation components, which are often listed in their own equipment specifications.

Safety-related issues (e.g. operating modes, operator actions with access to hazardous areas, EMERGENCY STOP concepts, etc.) should be clarified with customers early on so that they can be integrated in the risk assessment/risk reduction process.

8.2 General information about SINAMICS Safety Integrated

Safety Integrated function - STO

The Safe Torque Off (STO) is a safety function that prevents the drive from restarting unexpectedly, in accordance with EN 60204-1:2006 Section 5.4.

The STO function is in conformance with the IEC 61508, SIL2 standard, in the operating mode with a high demand, Category 3 and Performance Level d (PL d) acc. to ISO 13849-1:2006, as well as IEC 61800-5-2.

Controlling the STO Function

The STO function can be controlled via terminals. For the details about STO wiring, refer to the chapter "24V power supply/STO - X6 (Page 93)".

8.3 System features

8.3.1 Certification

The safety function of the SINAMICS V90 drive system meets the following requirements:

- Category 3 according to ISO 13849-1:2006
- Performance Level (PL) d to EN ISO 13849-1:2006
- Safety integrity level 2 (SIL 2) to IEC 61508

In addition, the safety function of SINAMICS V90 has been certified by independent institutes. An up-to-date list of certified components is available on request from your local Siemens office.

8.3.2 Safety instructions

Note

Additional safety information and residual risks not specified in this section are included in the chapter "Safety instructions (Page 11)".

 **DANGER**

Safety Integrated can be used to minimize the level of risk associated with machines and plants.

Machines and plants can only be operated safely in conjunction with Safety Integrated, however, when the machine manufacturer is familiar with and observes every aspect of this technical user documentation, including the documented general conditions, safety information, and residual risks.

Precisely knows and observes this technical user documentation - including the documented limitations, safety information and residual risks;

Carefully constructs and configures the machine/plant. A careful and thorough acceptance test must then be performed by qualified personnel and the results documented.

Implements and validates all the measures required in accordance with the machine/plant risk analysis by means of the programmed and configured Safety Integrated functions or by other means.

The use of Safety Integrated does not replace the machine/plant risk assessment carried out by the machine manufacturer as required by the EC machinery directive.

In addition to using Safety Integrated functions, further risk reduction measures must be implemented.

| |
|--|
|  WARNING |
| <p>The Safety Integrated functions cannot be activated until the system has been completely powered up. System startup is a critical operating state with increased risk. No personnel may be present in the immediate danger zone in this phase.</p> <p>The drives of vertical axes must be in torque state.</p> <p>A complete forced dormant error detection cycle is required after power on.</p> |

| |
|---|
|  WARNING |
| <p>EN 60204-1:2006</p> <p>Emergency Stop function must bring the machine to a standstill in accordance with STO.</p> <p>The machine must not restart automatically after EMERGENCY STOP.</p> <p>When the safety function is deactivated, an automatic restart is permitted under certain circumstances depending on the risk analysis (except when Emergency Stop is reset). An automatic start is permitted when a protective door is closed, for example.</p> |

| |
|---|
|  WARNING |
| <p>After hardware and/or software components have been modified or replaced, all protective equipment must be closed prior to system startup and drive activation. Personnel shall not be present within the danger zone.</p> <p>Before allowing anybody to re-enter the danger zone, you should test steady control response by briefly moving the drives in forward and reverse direction (+/-).</p> <p>To observe during power on:</p> <p>The Safety Integrated functions are only available and can only be selected after the system has completely powered up.</p> |

8.3.3 Probability of failure of the safety function (PHF value)

Probability of failure

The probability of the failure of safety functions must be specified in the form of a PFH value (Probability of Failure per Hour) in accordance with IEC 61508, IEC 62061, and ISO 13849-1:2006. The PFH value of a safety function depends on the safety concept of the drive unit and its hardware configuration, as well as on the PFH values of other components used for this safety function.

Corresponding PFH values are provided for the SINAMICS V90 drive system, depending on the hardware configuration (number of drives, control type, number of encoders used). The various integrated safety functions are not differentiated.

The PHF values can be requested from your local sales office.

8.3.4 Response time

Response time means the time from the control via terminals until the response actually occurs. The worst response time for the STO function is 5 ms.

8.3.5 Residual risk

The fault analysis enables the machine manufacturer to determine the residual risk at this machine with regard to the drive unit. The following residual risks are known:

| |
|--|
|  WARNING |
| Due to the intrinsic potential of hardware faults, electrical systems are subject to additional residual risk, which can be expressed by means of the PFH value. |

| |
|--|
|  WARNING |
| Simultaneous failure of two power transistors (one in the upper and the other offset in the lower inverter bridge) in the inverter may cause brief movement of the drive, depending on the number of poles of the motor. Maximum value of this movement: Synchronous rotary motors: Max. movement = $180^\circ / \text{no. of pole pairs}$ |

8.4 Safety Integrated basic functions

8.4.1 Safe Torque Off (STO)

In conjunction with a machine function or in the event of a fault, the "Safe Torque Off" (STO) function is used to safely disconnect the torque-generating energy feed to the motor.

When the function is selected, the drive unit is in a "safe status". The switching on inhibited function prevents the drive unit from being restarted.

The two-channel pulse suppression function integrated in the Motor Modules/Power Modules is a basis for this function.

Functional features of "Safe Torque Off"

- This function is integrated in the drive; this means that a higher-level controller is not required.
- The function is drive-specific, i.e. it is available for each drive and must be individually commissioned.

- When the "Safe Torque Off" function is selected, the following applies:
 - The motor cannot be started accidentally.
 - The pulse suppression safely disconnects the torque-generating energy feed to the motor.
 - The power unit and motor are not electrically isolated.
- By selecting/deselecting STO, in addition to the fault messages, the safety messages are also automatically withdrawn.

The STO function can be used wherever the drive naturally reaches a standstill due to load torque or friction in a sufficiently short time or when "coasting down" of the drive will not have any relevance for safety.

| |
|---|
|  WARNING |
| Appropriate measures must be taken to ensure that the motor does not undesirably move once the energy feed has been disconnected, e.g. against coasting down. |

| |
|--|
|  CAUTION |
| If two power transistors simultaneously fail in the power unit (one in the upper and one in the lower bridge), then this can cause brief momentary movement. The maximum movement can be: Synchronous rotary motors: Max. movement = $180^\circ / \text{No. of pole pairs}$ Synchronous linear motors: Max. movement = pole width |

Note

Closing delay of the holding brake

The closing signal (low level) of the holding brake is output 30 ms after the STO is triggered.

Preconditions for using the STO function

When use the STO function, the following preconditions should be fulfilled:

- Each monitoring channel (STO1 and STO2) triggers safe pulse suppression with its switch off signal path.
- If a motor holding brake is connected and configured, the connected brake is not safe because there is no safety function for brake, such as safe brake.

Behaviors of the STO function

| Terminal | | State | Action |
|------------|------------|-------|---|
| STO1 | STO2 | | |
| High level | High level | Safe | The servo motor can normally run when you power on the servo drive. |
| Low level | Low level | Safe | The servo drive starts up normally but the servo motor cannot run. |

| Terminal | | State | Action |
|------------|------------|--------|---|
| STO1 | STO2 | | |
| High level | Low level | Unsafe | Alarm occurs and servo motor coasts down. |
| Low level | High level | Unsafe | Alarm occurs and servo motor coasts down. |

Selecting/deselecting "Safe Torque Off"

The following is executed when "Safe Torque Off" is selected:

- Each monitoring channel triggers safe pulse suppression via its switch-off signal path.
- A motor holding brake is closed (if connected and configured).

Note

If "Safe Torque Off" is selected and de-selected through one channel within 2 seconds, the pulses are suppressed without a message being output.

Restart after the "Safe Torque Off" function has been selected

1. Deselect the function in each monitoring channel via the input terminals.
2. Issue drive enable signals.
3. Switch the drive back on.
 - 1/0 edge at input signal "ON/OFF1"
 - 0/1 edge at input signal "ON/OFF1" (switch on drive)
4. Operate the drives again.

Response time for the "Safe Torque Off" function

The worst response time for the STO function is 5 ms.

8.4.2 Forced dormant error detection

Forced dormant error detection or test of the switch-off signal paths for Safety Integrated Basic Functions

The forced dormant error detection function at the switch-off signal paths is used to detect software/hardware faults at both monitoring channels in time and is automated by means of activation/deactivation of the "Safe Torque Off" function.

To fulfill the requirements of ISO 13849-1:2006 regarding timely error detection, the two switch-off signal paths must be tested at least once within a defined time to ensure that they are functioning properly. This functionality must be implemented by means of forced dormant error detection function, triggered either in manual mode or by the automated process.

A timer ensures that forced dormant error detection is carried out as quickly as possible.

8760 hours for the forced dormant error detection.

Once this time has elapsed, an alarm is output and remains present until forced dormant error detection is carried out.

The timer returns to the set value each time the STO function is deactivated.

When the appropriate safety devices are implemented (e.g. protective doors), it can be assumed that running machinery will not pose any risk to personnel. For this reason, only an alarm is output to inform the user that a forced dormant error detection run is due and to request that this be carried out at the next available opportunity. This alarm does not affect machine operation.

Examples of when to carry out forced dormant error detection:

- When the drives are at a standstill after the system has been switched on (POWER ON).
- When the protective door is opened.
- At defined intervals.
- In automatic mode (time and event dependent)

Note

The timer will be reset if the associated forced dormant error detection is executed. The corresponding alarm is not triggered.

The forced dormant error detection procedure of Safety Function (STO) always has to be executed through the terminals.

The mission time of the devices is 40000 hours.

Tuning

9.1 Controller overview

The SINAMICS V90 servo drive consists of three control loops:

- Current control
- Speed control
- Position control

The following block diagram shows the relationship between these three control loops:

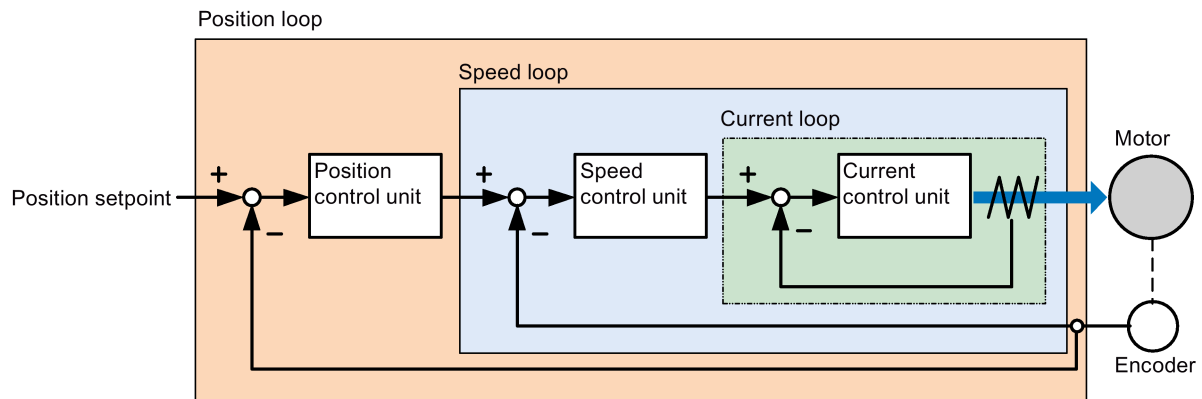

In theory, frequency width of the inside control loop **must** be wider than that of the outer control loop; otherwise, the whole control system can vibrate or have a low response level. The relationship between the frequency widths of these three control loops is as follows:

Current loop > speed loop > position loop

Since the current loop of SINAMICS V90 servo drive already has a perfect frequency width, it is only necessary for you to adjust the speed loop gain and the position loop gain.

Servo gains

- Position loop gain

Position loop gain directly influences the response level of the position loop. If the mechanical system does not vibrate or produce noises, you can increase the value of position loop gain so that the response level can be increased and positioning time can be shortened.

| Parameter | Value range | Default value | Unit | Description |
|-----------|----------------|-----------------|----------|----------------------|
| p29110[0] | 0.00 to 300.00 | Motor dependent | 1000/min | Position loop gain 1 |
| p29110[1] | 0.00 to 300.00 | 1.00 | 1000/min | Position loop gain 2 |

- Speed loop gain

Speed loop gain directly influences the response level of the speed loop. If the mechanical system does not vibrate or produce noises, you can increase the value of speed loop gain so that the response level can be increased.

| Parameter | Value range | Default value | Unit | Description |
|-----------|-------------|-----------------|---------|-------------------|
| p29120[0] | 0 to 999999 | Motor dependent | Nms/rad | Speed loop gain 1 |
| p29120[1] | 0 to 999999 | 0.3 | Nms/rad | Speed loop gain 2 |

- Speed loop integral gain

With adding integral component into speed loop, the servo drive can efficiently eliminate the steady-state error of speed and give response to a small change to speed.

Generally speaking, if the mechanical system does not vibrate or produce noises, you can decrease speed loop integral gain so that the system rigidity can be increased.

If the load inertia ratio is very high or the mechanical system has a resonance factor, it must be guaranteed that the speed loop integral time constant is big enough; otherwise, the mechanical system may have a resonance.

| Parameter | Value range | Default value | Unit | Description |
|-----------|-------------|---------------|------|------------------------------|
| p29121[0] | 0 to 100000 | 15 | ms | Speed loop integral time 1 |
| p29121[1] | 0 to 100000 | 20 | ms | Speed loop integral time 2 |
| p29022 | 1 to 10000 | 1 | - | Load moment of inertia ratio |

- Position loop feed forward gain

With position loop feed forward gain, the responsiveness level can be increased. If the position loop feed forward gain is too big, motor speed can have overshoots and the digital output signal INP can have a repeated on/off. You, therefore, must monitor the changes to speed waveform and the action of the digital output signal INP during adjustment. You can slowly adjust the position loop feed forward gain. The effect of feed forward function is not obvious if the position loop gain is too big.

| Parameter | Value range | Default value | Unit | Description |
|-----------|----------------|---------------|------|---------------------------------|
| p29111 | 0.00 to 200.00 | 0 | % | Position loop feed forward gain |

9.2 First time commissioning mode

Responsivity of a machine can be optimized by tuning. The responsivity is reflected by dynamic factor and determined by the servo gains that is set in the servo drive.

The servo gains are set by using a combination of parameters. These parameters influence each other so you must consider the balance between set values when setting these values.

Generally, the responsivity of a machine with high rigidity can be improved by increasing the servo gains; however, if the servo gains of a machine with low rigidity are increased, the machine can vibrate and the responsivity cannot be improved.

| |
|---|
| NOTICE |
| Effectiveness of servo gains |
| The tuning function only uses the first group of servo gains (position loop gain 1, speed loop gain 1 and speed loop integral time 1). |

The following tuning functions are available for the SINAMICS V90 servo drive.

Select a tuning mode by setting the parameter p29021:

| Parameter | Setting value | Description | Estimation of load inertia moment ratio |
|-----------|---------------|---|---|
| p29021 | 0 (default) | Auto tuning is disabled (manual tuning) without changing servo gains relevant parameters. | - |
| | 3 | Real-time auto tuning for positioning Identify load inertia moment ratio and automatically adjust servo gains when performing single servo drive positioning. | Always estimated |
| | 4 | Real-time auto tuning for interpolation Identify load inertia moment ratio and automatically adjust servo gains when performing interpolation operation of two or more servo drives. | Always estimated |
| | 5 | Auto tuning is disabled (manual tuning). All servo gains relevant parameters are set to default values. | - |

Tuning with SINAMICS V-ASSISTANT

You can also perform tuning with the engineering tool SINAMICS V-ASSISTANT. For more information, refer to SINAMICS V-ASSISTANT Online Help.

9.2.1 Basic tuning procedure

Proceed as follows to perform tuning for the SINAMICS V90 servo drive:

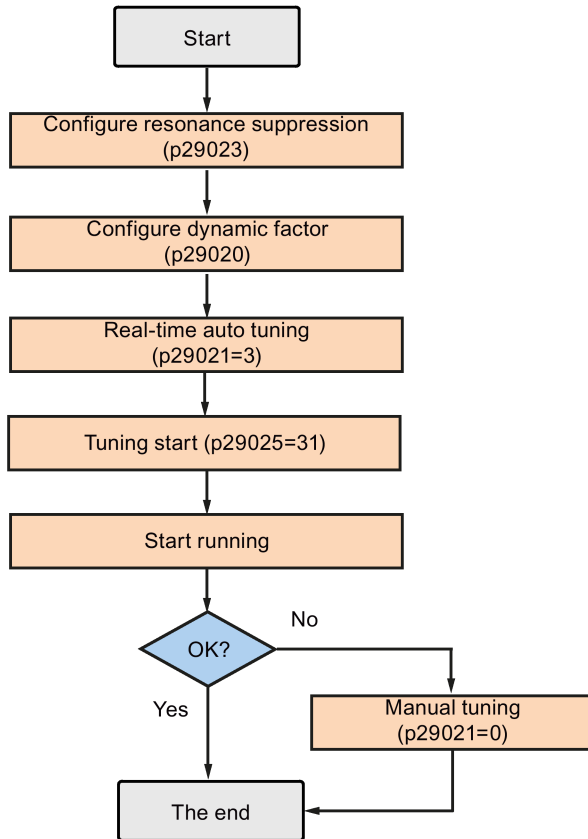

9.2.2 Configuration of dynamic factor

You can configure the dynamic factor of the servo system with the parameter p29020. Higher dynamic factor means higher tracking ability and shorter settling time but also higher possibility of resonance. You should find a desired dynamic factor within a resonance-free range.

31 dynamic factors are available for the SINAMICS V90 servo drive:

| Dynamic factor (p29020) | Machine rigidity |
|-------------------------|------------------|
| 1 | Low |
| 2 | |
| 3 | |
| 4 | |
| 5 | |
| 6 | |
| 7 | |
| 8 | |

| Dynamic factor (p29020) | Machine rigidity |
|-------------------------|------------------|
| 9 | ↑ |
| 10 | |
| 11 | |
| 12 | |
| 13 | |
| 14 | |
| 15 | |
| 16 | Middle |
| 17 | |
| 18 | ↓ |
| 19 | |
| 20 | |
| 21 | |
| 22 | |
| 23 | |
| 24 | |
| 25 | |
| 26 | |
| 27 | |
| 28 | |
| 29 | |
| 30 | |
| 31 | |

If the dynamic factor setting cannot be increased up to the desired level because of machine resonance beyond 250Hz, the function of resonance suppression can be used to suppress machine resonance and thus increase dynamic factor. Refer to Section "Resonance suppression (Page 204)" for detailed information about the function of resonance suppression.

9.3 Real-time auto tuning

Real-time auto tuning has two kinds of applications:

- for positioning (p29021=3): adjust servo gains when performing single servo drive positioning.
- for interpolation (p29021=4): adjust servo gains when performing interpolation operation of two or more servo drives. In this case, the tuning pre-control time constant p29028 must be set to an equal value in each drive.

With the real-time auto tuning, the servo drive can automatically estimate the load moment of inertia ratio and set the optimum gains accordingly at real time.

The following servo gains relevant parameters can be set automatically when you choose to use the real-time auto tuning:

| Parameter | Value range | Default Value | Unit | Description |
|-----------|----------------|-----------------|----------|---------------------------------|
| p29022 | 1 to 10000 | 1 | - | Load moment of inertia ratio |
| p29025 | 0 to 63 | 13 | - | Configuration of auto tuning |
| p29110[0] | 0.00 to 300.00 | Motor dependent | 1000/min | Position loop gain 1 |
| p29120[0] | 0 to 999999 | Motor dependent | Nms/rad | Speed loop gain 1 |
| p29121[0] | 0 to 100000 | 15 | ms | Speed loop integral time 1 |
| p29111 | 0.00 to 200.00 | 0.00 | % | Position loop feed forward gain |

Note

After the real-time auto tuning is activated, do not change other auto tuning related control/filter parameters since these parameters can be set automatically and your changes will not be accepted.

Note

Pre-conditions for the real-time auto tuning

The real-time auto tuning may not be performed properly if the following conditions are not satisfied:

- Time to reach 2000 rpm is the acceleration/deceleration time constant of 5s or less.
- Speed is 150 rpm or higher. The ratio of load inertia moment to servo motor inertia moment is 100 times or less.
- The acceleration/deceleration torque is 10% or more of the rated torque.

Under operating conditions that impose sudden disturbance torque during acceleration/deceleration or on a machine that is extremely loose, auto tuning may not function properly, either. In such cases, use the manual tuning to make gain adjustment.

9.4 Manual tuning

When the auto tuning cannot reach expected tuning results, you can disable the auto tuning function by setting the parameter p29021 and manually perform tuning:

- p29021=5: auto tuning function is disabled and all control parameters (servo gains) are reset to default values.
- p29021=0: auto tuning function is disabled without changing control parameters (servo gains).

Procedure for manual tuning

Follow the procedure below to perform manual tuning:

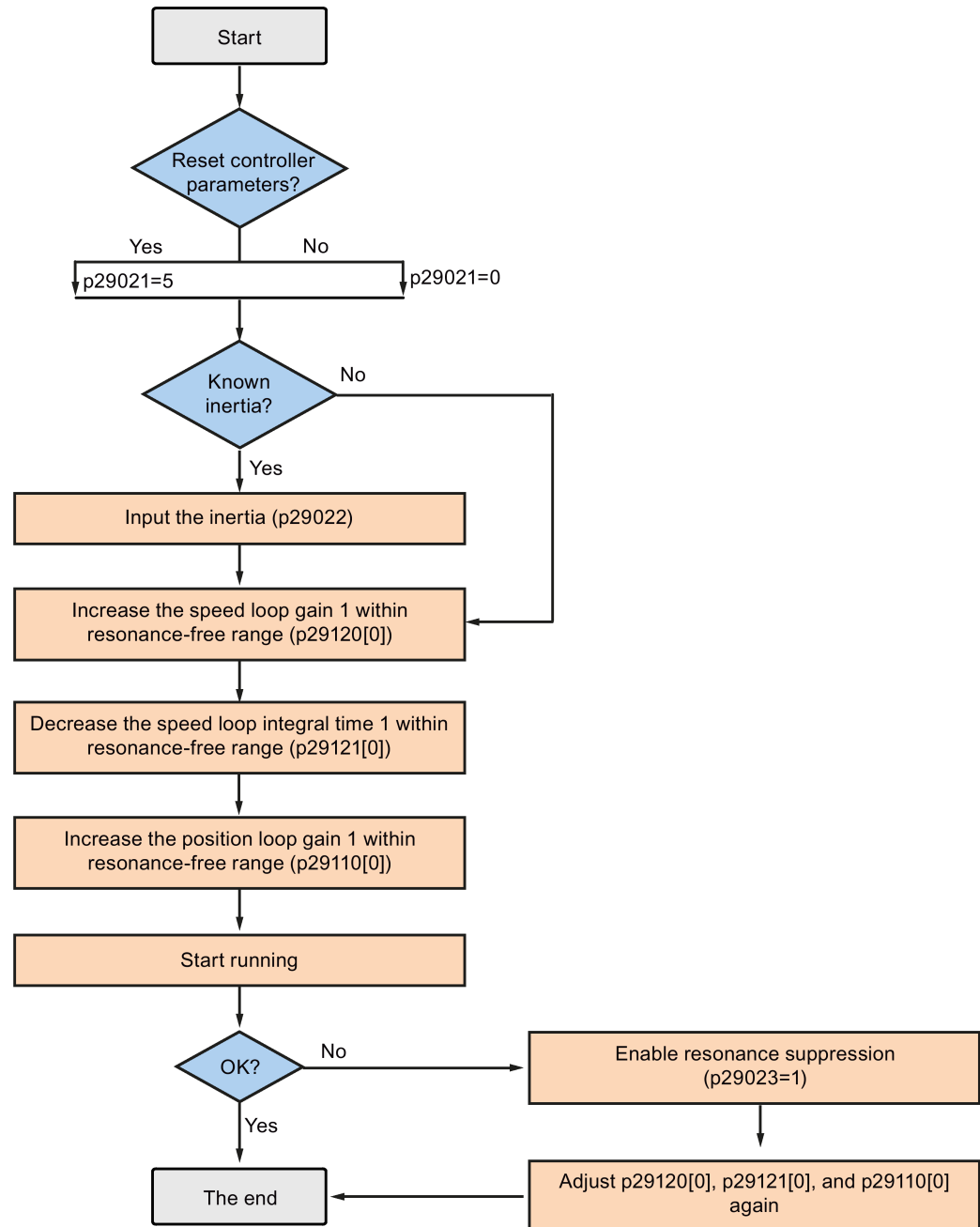

Note

Resonance suppression

For detailed information about the resonance suppression, refer to Section "Resonance suppression (Page 204)".

Parameter settings

You need to set the following parameters when using the manual tuning function:

| Parameter | Value range | Default value | Unit | Description |
|-----------|----------------|-----------------|----------|------------------------------|
| p29022 | 1 to 10000 | 1 | - | Load moment of inertia ratio |
| p29110[0] | 0.00 to 300.00 | Motor dependent | 1000/min | Position loop gain 1 |
| p29120[0] | 0 to 999999 | Motor dependent | Nms/rad | Speed loop gain 1 |
| p29121[0] | 0 to 100000 | 15 | ms | Speed loop integral time 1 |

9.5 Resonance suppression

The resonance suppression function is filter (notch filter) function. It detects mechanical resonance at a frequency between 250 Hz and 1500 Hz, and decreases the gain of specific frequency (by automatically setting notch filter) to suppress the mechanical resonance.

The gain decreasing frequency, width as well as depth can be set by setting the notch filter:

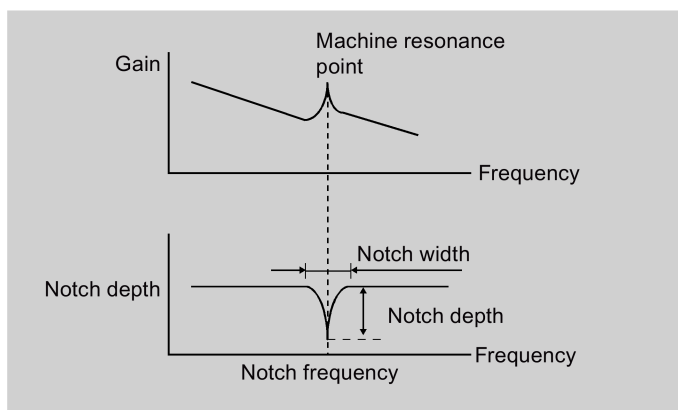

Selecting a resonance suppression mode

Three modes are available for this function. You can select one of them by setting the parameter p29023:

| Parameter | Value range | Value | Unit | Description |
|-----------|-------------|-------|------|---|
| p29023 | 0 to 2 | 0 | - | Resonance suppression mode: <ul style="list-style-type: none"> • 0: resonance suppression deactivated (manual input of resonance frequency) • 1: real-time resonance suppression • 2: one-time resonance frequency search with excitation |

Note

Perform manual tuning to increase the responsivity after executing this function.

The real-time resonance suppression can be used together with auto-tuning.

The basic operating sequence to use the function of resonance suppression is shown as follows:

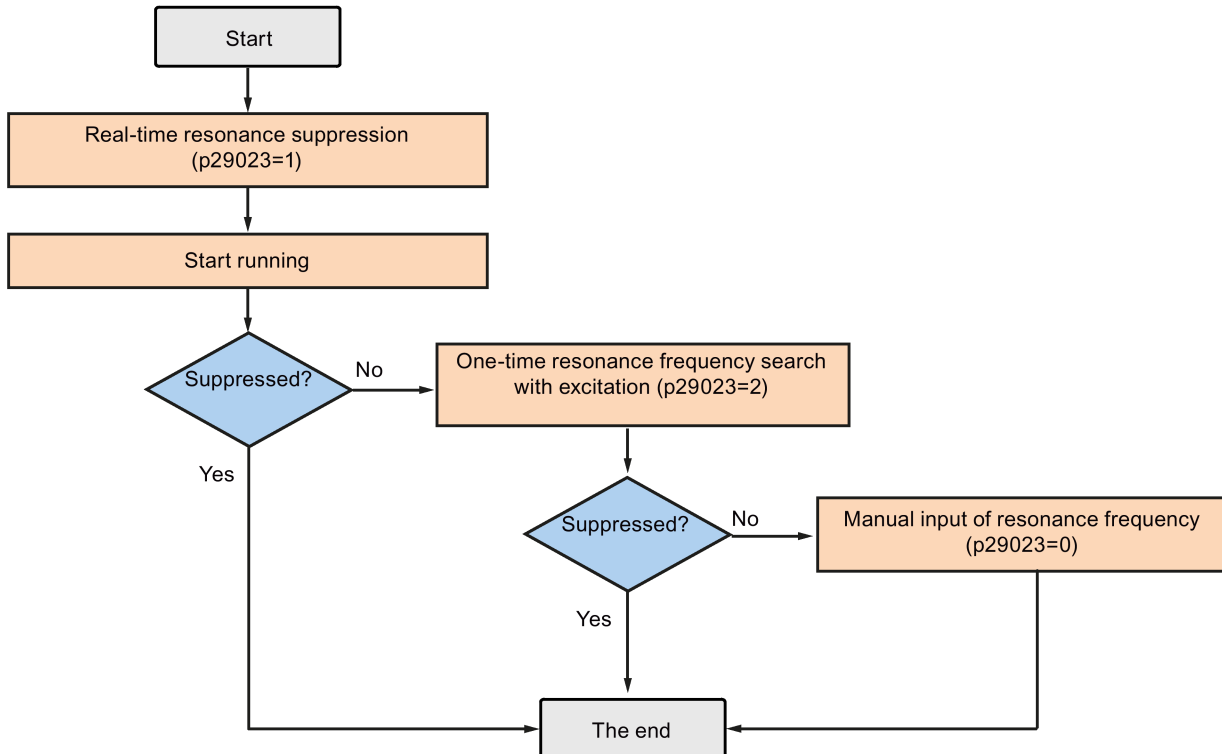

Real-time resonance suppression (p29023=1)

When you choose to use the real-time resonance suppression, the servo drive performs real-time detection of the resonance frequency and configures the following notch filter relevant parameters accordingly:

| Parameter | Value range | Value | Unit | Description |
|-----------|--------------|-------|------|--|
| p1662 | 1 to 2 | 1 | - | Current notch filter type: <ul style="list-style-type: none"> • 1: 2-step lowpass filter • 2: 2-step general filter |
| p1663 | 0.5 to 16000 | 1999 | - | Natural frequency of current notch filter (2-step lowpass filter or 2-step general filter) denominator. |
| p1664 | 0.001 to 10 | 0.7 | - | Damp of current notch filter (2-step lowpass filter or 2-step general filter) denominator. |

| Parameter | Value range | Value | Unit | Description |
|-----------|--------------|-------|------|--|
| p1665 | 0.5 to 16000 | 1999 | - | Natural frequency of current notch filter (2-step general filter) numerator. |
| p1666 | 0.001 to 10 | 0.7 | - | Damp of current notch filter (2-step general filter) numerator. |

One-time resonance frequency search with excitation (p29023=2)

Before you use the one-time resonance frequency search with excitation, make sure the load is mounted as required and the servo motor can rotate freely. When you choose to use the one-time resonance frequency search, the servo motor runs for 10 seconds. During this time, the servo drive generates a test signal that helps detect the most powerful mechanical resonance frequency. At the end of this time, the servo drive automatically sets the following notch filter relevant parameters and deactivates the resonance suppression function (p29023=0):

| Parameter | Value range | Value | Unit | Description |
|-----------|--------------|-------|------|---|
| p1662 | 1 to 2 | 1 | - | Current notch filter type: <ul style="list-style-type: none"> 1: 2-step lowpass filter 2: 2-step general filter |
| p1663 | 0.5 to 16000 | 1999 | - | Natural frequency of current notch filter (2-step lowpass filter or 2-step general filter) denominator. |
| p1664 | 0.001 to 10 | 0.7 | - | Damp of current notch filter (2-step lowpass filter or 2-step general filter) denominator. |
| p1665 | 0.5 to 16000 | 1999 | - | Natural frequency of current notch filter (2-step general filter) numerator. |
| p1666 | 0.001 to 10 | 0.7 | - | Damp of current notch filter (2-step general filter) numerator. |

Note

Notch filter remains active when the resonance suppression function is activated automatically.

You can deactivate the notch filter by setting the parameter p1656: bit 1 = 0.

Manual input of resonance frequency (p29023=0)

When both the real-time resonance suppression and the one-time resonance frequency search with excitation cannot reach the suppression effect, you can do the resonance suppression by manually setting the following parameters:

| Parameter | Value range | Value | Unit | Description |
|-----------|--------------|-------|------|---|
| p1662 | 1 to 2 | 1 | - | Current notch filter type: <ul style="list-style-type: none"> 1: 2-step lowpass filter 2: 2-step general filter |
| p1663 | 0.5 to 16000 | 1999 | - | Natural frequency of current notch filter (2-step lowpass filter or 2-step general filter) denominator. |

| Parameter | Value range | Value | Unit | Description |
|-----------|--------------|-------|------|--|
| p1664 | 0.001 to 10 | 0.7 | - | Damp of current notch filter (2-step lowpass filter or 2-step general filter) denominator. |
| p1665 | 0.5 to 16000 | 1999 | - | Natural frequency of current notch filter (2-step general filter) numerator. |
| p1666 | 0.001 to 10 | 0.7 | - | Damp of current notch filter (2-step general filter) numerator. |

Assume the notch frequency is f_{sp} , notch width is f_{BB} , and notch depth is K , then the filter parameters can be calculated as follows:

$$p1663=p1665=f_{sp}$$

$$p1664=f_{BB} / (2 \times f_{sp})$$

$$p1666=(f_{BB} \times 10^{(k/20)}) / (2 \times f_{sp})$$

9.6 Gain switching

Note

The Gain Switching function is **not** available in **T** mode (torque control mode).

The function of auto-tuning must be disabled so that the function of gain switching can be available.

With this function, you can:

- increase the gains during servo lock and decrease gains to reduce noise during rotation.
- increase the gains during settling to shorten the stop settling time.
- switch between two groups of gains using an external signal (G-CHANGE) to ensure stability of the servo system because the load inertia moment ratio varies greatly during a stop (for example, a large load is mounted on a carrier).

Selection of a gain switching mode

Five gain switching modes in total are available:

- Gain switching disabled
- Gain switching using digital input signal (G-CHANGE)
- Gain switching using position deviation
- Gain switching using position setpoint frequency
- Gain switching using actual speed

You can select one of the five modes by setting parameter p29130:

| Parameter | Value | Description |
|-----------|-------------|---|
| p29130 | 0 (default) | The function of gain switching is disabled. Only the first group of gains is valid and the function of PI to P switching of speed controller is enabled. |
| | 1 | Gain switching using digital input signal (G-CHANGE). When G-CHANGE is 0, the first group of gains is selected; when G-CHANGE is 1, the second one is selected. |
| | 2 | Gain switching using position deviation. In the position control mode, gain switching can be decided by position deviation. If the position deviation is less than preset value, the first group of gains is selected; otherwise, the second one is selected. |
| | 3 | Gain switching using position setpoint frequency. In the position control mode, gain switching can also be decided by position setpoint frequency. If the position setpoint frequency is less than preset value, the first group of gain is selected; otherwise, the second one is selected. |
| | 4 | In the speed control mode, gain switching can be decided by actual speed. If the actual speed is below preset value; otherwise, the second one is selected. |

9.6.1 Gain switching using an external digital input signal (G-CHANGE)

DI settings

- Position control mode

| Signal | Pin assignment | Setting | Description |
|----------|------------------------|---------|--|
| G-CHANGE | X8-9 (factory setting) | 0 | The first group of gains is selected. |
| | | 1 | The second group of gains is selected. |

- Speed control mode

| Signal | Pin assignment | Setting | Description |
|----------|----------------|---------|--|
| G-CHANGE | - | 0 | The first group of gains is selected. |
| | | 1 | The second group of gains is selected. |

Parameter settings (p29130 = 1)

| Parameter | Value range | Default value | Unit | Description |
|-----------|----------------|-----------------|----------|----------------------|
| p29110[0] | 0.00 to 300.00 | Motor dependent | 1000/min | Position loop gain 1 |
| p29110[1] | 0.00 to 300.00 | 1.00 | 1000/min | Position loop gain 2 |
| p29120[0] | 0 to 999999 | Motor dependent | Nms/rad | Speed loop gain 1 |
| p29120[1] | 0 to 999999 | 0.3 | Nms/rad | Speed loop gain 2 |

| Parameter | Value range | Default value | Unit | Description |
|-----------|-------------|---------------|------|---|
| p29121[0] | 0 to 100000 | 15 | ms | Speed loop integral time 1 |
| p29121[1] | 0 to 100000 | 20 | ms | Speed loop integral time 2 |
| p29139 | 8 to 1000 | 20 | ms | Time constant to smooth the switching between gain sets |

Timing diagram

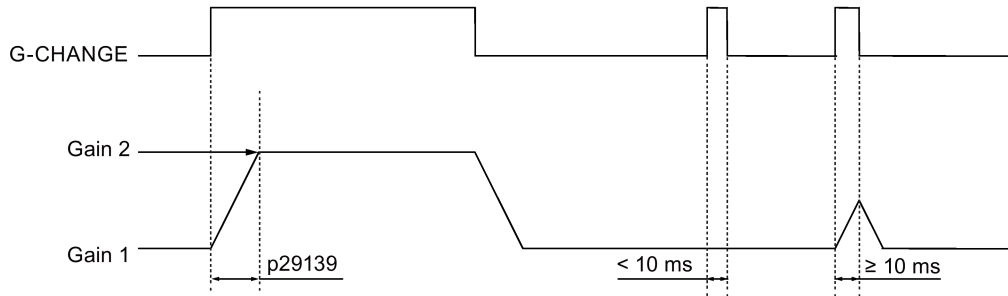

Note

If the pulse duration is shorter than 10 ms, there is no reaction.

9.6.2 Gain switching using position deviation

Parameter settings (p29130 = 2)

| Parameter | Value range | Default value | Unit | Description |
|-----------|-----------------|-----------------|----------|--|
| p29110[0] | 0.00 to 300.00 | Motor dependent | 1000/min | Position loop gain 1 |
| p29110[1] | 0.00 to 300.00 | 1.00 | 1000/min | Position loop gain 2 |
| p29120[0] | 0 to 999999 | Motor dependent | Nms/rad | Speed loop gain 1 |
| p29120[1] | 0 to 999999 | 0.3 | Nms/rad | Speed loop gain 2 |
| p29121[0] | 0 to 100000 | 15 | ms | Speed loop integral time 1 |
| p29121[1] | 0 to 100000 | 20 | ms | Speed loop integral time 2 |
| p29131 | 0 to 2147483647 | 100 | LU | Position deviation threshold for automatically triggering gain switching |
| p29139 | 8 to 1000 | 20 | ms | Time constant to smooth the switching between gain sets |

Timing diagram

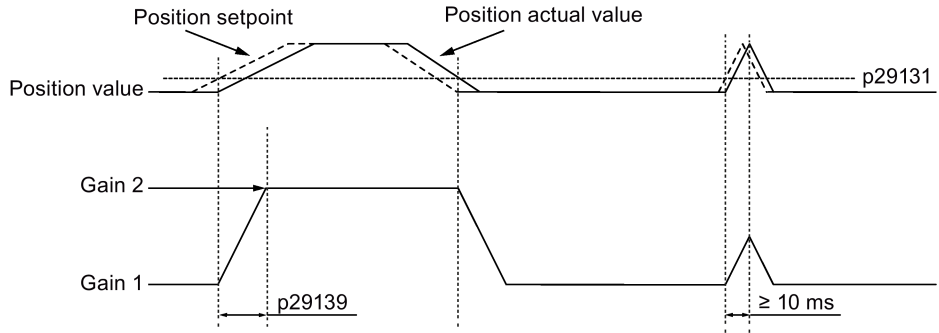

9.6.3 Gain switching using position setpoint frequency

Parameter settings (p29130 = 3)

| Parameter | Value range | Setting value | Unit | Description |
|-----------|-----------------|-----------------|-------------|---|
| p29110[0] | 0.00 to 300.00 | Motor dependent | 1000/min | Position loop gain 1 |
| p29110[1] | 0.00 to 300.00 | 1.00 | 1000/min | Position loop gain 2 |
| p29120[0] | 0 to 999999 | Motor dependent | Nms/rad | Speed loop gain 1 |
| p29120[1] | 0 to 999999 | 0.3 | Nms/rad | Speed loop gain 2 |
| p29121[0] | 0 to 100000 | 15 | ms | Speed loop integral time 1 |
| p29121[1] | 0 to 100000 | 20 | ms | Speed loop integral time 2 |
| p29132 | 0 to 2147000064 | 100 | 1000 LU/min | Position setpoint frequency threshold for automatically triggering gain switching |
| p29139 | 8 to 1000 | 20 | ms | Time constant to smooth the switching between gain sets |

Timing diagram

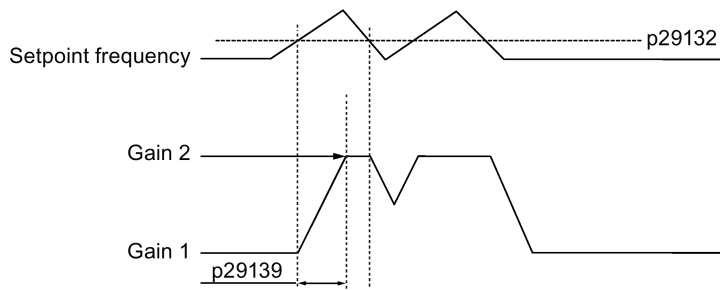

9.6.4 Gain switching using actual speed

Parameter settings (p29130 = 4)

| Parameter | Value range | Setting value | Unit | Description |
|-----------|-----------------|-----------------|----------|---|
| p29110[0] | 0.00 to 300.00 | Motor dependent | 1000/min | Position loop gain 1 |
| p29110[1] | 0.00 to 300.00 | 1.00 | 1000/min | Position loop gain 2 |
| p29120[0] | 0 to 999999 | Motor dependent | Nms/rad | Speed loop gain 1 |
| p29120[1] | 0 to 999999 | 0.3 | Nms/rad | Speed loop gain 2 |
| p29121[0] | 0 to 100000 | 15 | ms | Speed loop integral time 1 |
| p29121[1] | 0 to 100000 | 20 | ms | Speed loop integral time 2 |
| p29133 | 0 to 2147000064 | 100 | rpm | Speed threshold for automatically triggering gain switching |
| p29139 | 8 to 1000 | 20 | ms | Time constant to smooth the switching between gain sets |

Timing diagram

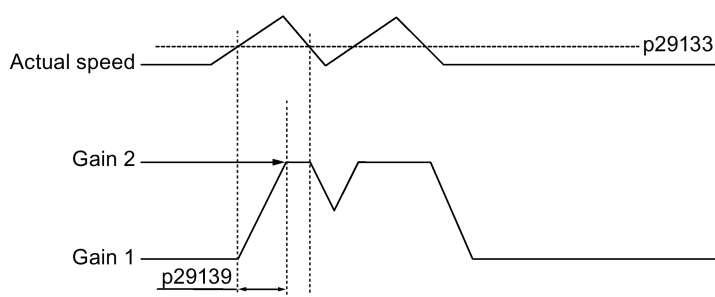

9.7 PI/P switching

Note

PI/P switching

Function of PI/P switching is **not** available for the **T** mode (torque control mode).

The functions of auto-tuning and gain switching must be disabled so that the function of PI/P switching can be available.

The PI/P switching will respond with a delay time of several milliseconds.

The function of PI/P switching is used to switch from **PI** (Proportional/Integral) control of speed controller to **P** (Proportional) control. With this function, you can:

- shorten the position setting time (for the position control mode).
- avoid overshooting of actual speed value during acceleration or deceleration (for the speed control mode).
- avoid unnecessary torque when the target position is at a mechanical limitation (for the position control mode).

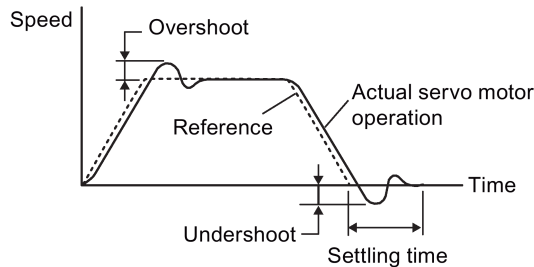

Selection of a switching mode for PI/P switching

Five switching modes in total are available for PI/P switching:

- using torque setpoint
- using an external digital input signal (G-CHANGE)
- using speed setpoint
- using acceleration setpoint
- using pulse deviation

You can select one of the switching modes by setting parameter p29140:

| Parameter | Value | Description |
|-----------|-------------|---|
| p29140 | 0 (default) | Disabled. |
| | 1 | Torque is higher than a parameterizable setting value. |
| | 2 | Using the digital input signal (G-CHANGE) |
| | 3 | Speed is higher than a parameterizable setting value. |
| | 4 | Acceleration is higher than a parameterizable setting value. |
| | 5 | Pulse deviation is higher than a parameterizable setting value. |

Example

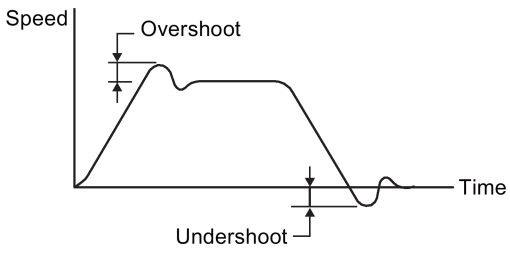
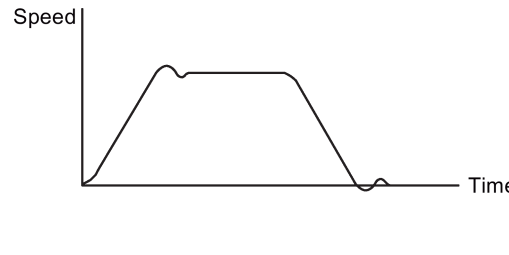
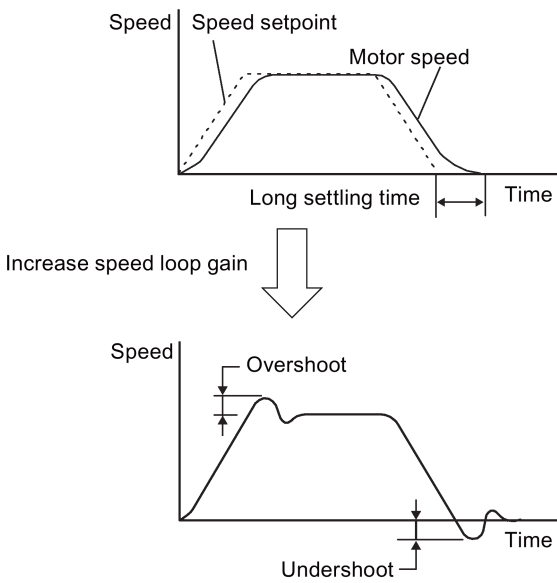
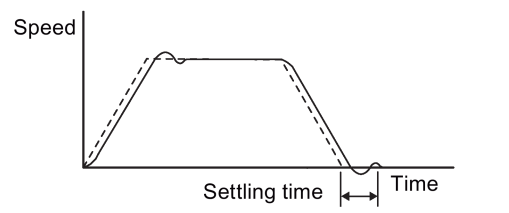
| Without the function of PI/P switching | With the function of PI/P switching |
|--|---|
| <p>Example 1: If the PI/P switching is not used, the speed of the motor may overshoot or undershoot due to torque saturation during acceleration or deceleration. The mode switching function suppresses torque saturation and eliminates the overshooting or undershooting of the motor speed.</p> | |
|  <p>Speed vs Time graph showing overshoot and undershoot.</p> |  <p>Speed vs Time graph showing smooth response with PI/P switching.</p> |
| <p>Example 2: The function of PI/P switching can be used to suppress overshooting and undershooting when speed loop gain is increased</p> | |
|  <p>Speed vs Time graph showing long settling time and overshoot/undershoot.</p> <p>Increase speed loop gain</p> |  <p>Speed vs Time graph showing reduced settling time with PI/P switching.</p> |

9.7.1 PI/P switching using torque setpoint

When torque setpoint exceeds preset torque value (p29141), the speed loop is switched from PI control to P control.

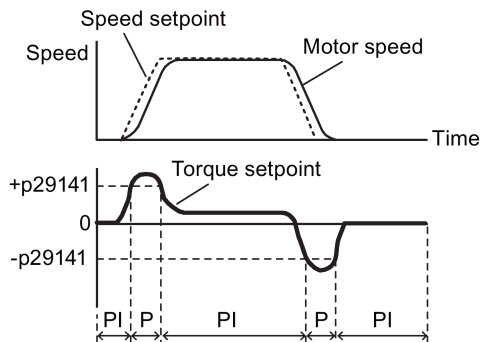

Parameter settings

| Parameter | Value range | Setting value | Unit | Description |
|-----------|-------------|---------------|---------|--|
| p29140 | 0 to 5 | 0 (default) | - | Switches PI control to P control using torque setpoint |
| p29141 | 0 to 300 | 200 (default) | % | Torque threshold for automatically triggering PI to P switch |
| p29120[0] | 0 to 999999 | 0.3 (default) | Nms/rad | Speed loop gain 1 |
| p29121[0] | 0 to 100000 | 15 (default) | ms | Speed loop integral time 1 |

Note

Speed setpoint

For detailed information about speed setpoint, refer to "Configuring speed setpoint (Page 164)".

Torque setpoint

For detailed information about torque setpoint, refer to "Torque setpoint (Page 171)".

9.7.2 PI/P switching using an external digital input signal (G-CHANGE)

DI settings

- Position control mode

| Signal | Pin assignment | Setting | Description |
|----------|------------------------|---------|--|
| G-CHANGE | X8-9 (factory setting) | 0 | The first group of gains is selected. |
| | | 1 | The second group of gains is selected. |

- Speed control mode

| Signal | Pin assignment | Setting | Description |
|----------|----------------|---------|--|
| G-CHANGE | - | 0 | The first group of gains is selected. |
| | | 1 | The second group of gains is selected. |

Parameter settings

| Parameter | Value range | Setting value | Unit | Description |
|-----------|-------------|---------------|---------|--|
| p29140 | 0 to 5 | 0 (default) | - | Switches PI control to P control using torque setpoint |
| p29120[0] | 0 to 999999 | 0.3 (default) | Nms/rad | Speed loop gain 1 |
| p29121[0] | 0 to 100000 | 15 (default) | ms | Speed loop integral time 1 |

Timing diagram

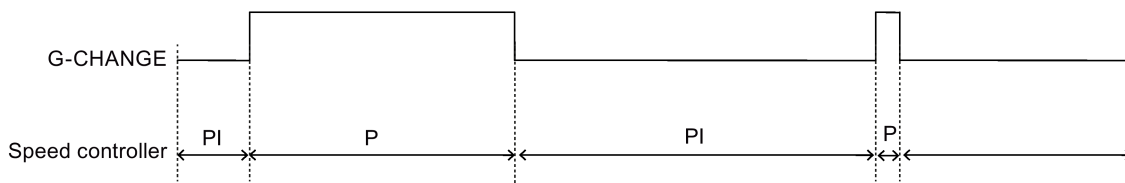

9.7.3 PI/P switching using speed setpoint

When the speed setpoint exceeds the preset speed value (p29142), the speed loop is switched from PI control to P control.

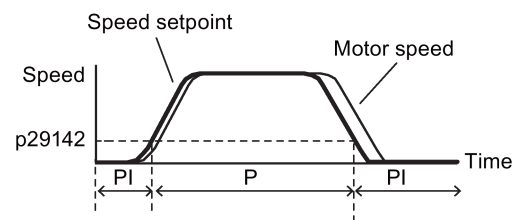

Parameter settings

| Parameter | Value range | Setting value | Unit | Description |
|-----------|-------------|----------------|---------|--|
| p29140 | 0 to 5 | 2 | - | Switches PI control to P control using speed setpoint. |
| p29142 | 0 to 210000 | 2000 (default) | rpm | Speed threshold for automatically triggering PI to P switch. |
| p29120[0] | 0 to 999999 | 0.3 (default) | Nms/rad | Speed loop gain 1 |
| p29121[0] | 0 to 100000 | 15 (default) | ms | Speed loop integral time 1 |

Note

For detailed information about speed setpoint, refer to "Configuring speed setpoint (Page 164)".

9.7.4 PI/P switching using acceleration setpoint

When the motor acceleration exceeds the preset acceleration rate (p29143), the speed loop is switched from PI control to P control.

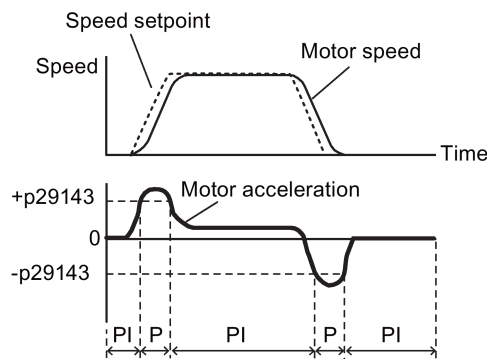

Parameter settings

| Parameter | Value range | Setting value | Unit | Description |
|-----------|-------------|---------------|--------------------|---|
| p29140 | 0 to 5 | 3 | - | Switches PI control to P control using acceleration setpoint. |
| p29143 | 0 to 30000 | 20 (default) | rev/s ² | Acceleration threshold for automatically triggering PI to P switch. |
| p29120[0] | 0 to 999999 | 0.3 (default) | Nms/rad | Speed loop gain 1 |
| p29121[0] | 0 to 100000 | 15 (default) | ms | Speed loop integral time 1 |

Note

Speed setpoint

For detailed information about speed setpoint, refer to "Configuring speed setpoint (Page 164)".

Acceleration

For detailed information about acceleration, refer to "Setting fixed position setpoint (Page 149)" of the internal position control mode.

9.7.5 PI/P switching using pulse deviation

The speed loop is switched from PI control to P control when the pulse deviation exceeds the preset value (p29144).

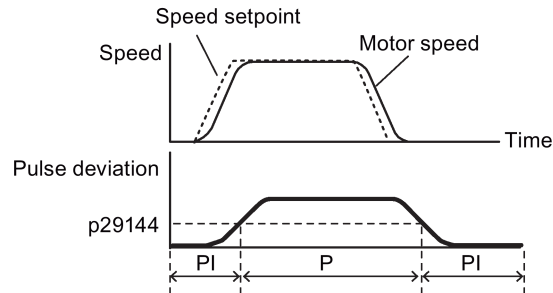

Parameter settings

| Parameter | Value range | Setting value | Unit | Description |
|-----------|-----------------|-----------------|---------|--|
| p29140 | 0 to 5 | 4 | - | Switches PI control to P control using pulse deviation |
| p29144 | 0 to 2147483647 | 30000 (default) | - | Pulse deviation threshold for automatically triggering PI to P switching |
| p29120[0] | 0 to 999999 | 0.3 (default) | Nms/rad | Speed loop gain 1 |
| p29121[0] | 0 to 100000 | 15 (default) | ms | Speed loop integral time 1 |

Note

Speed setpoint

For detailed information about speed setpoint, refer to "Configuring speed setpoint (Page 164)".

Parameters

10.1 Overview

Parameter number

Numbers prefixed with an "r" indicate that parameter is a read-only parameter.

Numbers prefixed with a "P" indicate that the parameter is an editable parameter.

Effective

Indicates the conditions for making parameterization effective. Two conditions are possible:

- IM (**I**mmediately): Parameter value becomes effective immediately after changing.
- RE (**R**eset): Parameter value becomes effective after repower-on.

Can be changed

This indicates when the parameter can be changed. Two states are possible:

- U (Run): Can be changed in the "**R**unning" state when the drive is in the servo on state. The "RDY" LED lights up green.
- T (Ready to run): Can be changed in the "**R**eady" state when the drive is in the servo off state. The "RDY" LED lights up red.

Note

When judging the state of the drive according to the "RDY" LED, ensure that no faults or alarms exist.

Data type

| Type | Description |
|--------|------------------------------|
| I16 | 16-bit integer |
| I32 | 32-bit integer |
| U16 | 16 bits without sign |
| U32 | 32 bits without sign |
| Uint16 | 16-bit unsigned integer |
| Uint32 | 32-bit unsigned integer |
| Float | 32-bit floating point number |

Parameter groups

The SINAMICS V90 parameters are divided into the following groups:

| Parameter group | Available parameters | Parameter group display on the BOP |
|------------------------------|--------------------------|------------------------------------|
| Basic parameters | p290xx | P 0A |
| Gain adjustment parameters | p291xx | P 0b |
| Speed control parameters | p10xx to p14xx, p21xx | P 0c |
| Torque control parameters | p15xx to p16xx | P 0d |
| Position control parameters | p25xx to p26xx, p292xx | P 0E |
| I/O parameters | p293xx | P 0F |
| Status monitoring parameters | All read-only parameters | dAtA |

10.2 Parameter list

Editable parameters

| Par. No. | Name | Min | Max | Factory Setting | Unit | Data type | Effective | Can be changed |
|----------|--|-------------|------------|---------------------|------|-----------|-----------|----------------|
| p1001 | Fixed speed setpoint 1 | -210000.000 | 210000.000 | 0.000 | rpm | Float | IM | T, U |
| | Description: Sets a value for the fixed speed / velocity setpoint 1. | | | | | | | |
| p1002 | Fixed speed setpoint 2 | -210000.000 | 210000.000 | 0.000 | rpm | Float | IM | T, U |
| | Description: Sets a value for the fixed speed / velocity setpoint 2. | | | | | | | |
| p1003 | Fixed speed setpoint 3 | -210000.000 | 210000.000 | 00.000 | rpm | Float | IM | T, U |
| | Description: Sets a value for the fixed speed / velocity setpoint 3. | | | | | | | |
| p1004 | Fixed speed setpoint 4 | -210000.000 | 210000.000 | 0.000 | rpm | Float | IM | T, U |
| | Description: Sets a value for the fixed speed / velocity setpoint 4. | | | | | | | |
| p1005 | Fixed speed setpoint 5 | -210000.000 | 210000.000 | 0.000 | rpm | Float | IM | T, U |
| | Description: Sets a value for the fixed speed / velocity setpoint 5. | | | | | | | |
| p1006 | Fixed speed setpoint 6 | -210000.000 | 210000.000 | 0.000 | rpm | Float | IM | T, U |
| | Description: Sets a value for the fixed speed / velocity setpoint 6. | | | | | | | |
| p1007 | Fixed speed setpoint 7 | -210000.000 | 210000.000 | 0.000 | rpm | Float | IM | T, U |
| | Description: Sets a value for the fixed speed / velocity setpoint 7. | | | | | | | |
| p1058 | Jog 1 speed setpoint | 0.00 | 210000.000 | 100.00 | rpm | Float | IM | T |
| | Description: Sets the speed/velocity for jog 1. Jogging is level-triggered and allows the motor to be incrementally moved. | | | | | | | |
| | Note: The parameter values displayed on the BOP are integers. | | | | | | | |
| p1082 * | Description: Maximum speed | 0.000 | 210000.000 | 1500.00 0 | rpm | Float | IM | T |
| | Description: Sets the highest possible speed. | | | | | | | |
| | Notice: After the value has been modified, no further parameter modifications can be made. | | | | | | | |
| | Note: The parameter values displayed on the BOP are integers. The parameter applies for both motor directions. The parameter has a limiting effect and is the reference quantity for all ramp-up and ramp-down times (e.g. down ramps, ramp-function generator and motor potentiometer). The range of the parameter is different when connect with different motors. | | | | | | | |
| | | | | | | | | |
| p1083 * | Speed limit in positive direction of rotation | 0.000 | 210000.000 | 210000. 000 | rpm | Float | IM | T, U |
| | Description: Sets the maximum speed for the positive direction. | | | | | | | |
| | Note: The parameter values displayed on the BOP are integers. | | | | | | | |
| p1086 * | Speed limit in negative direction of rotation | -210000.000 | 0.000 | - 210000. 000 | rpm | Float | IM | T, U |
| | Description: Sets the speed limit for the negative direction. | | | | | | | |
| | Note: The parameter values displayed on the BOP are integers. | | | | | | | |

10.2 Parameter list

| Par. No. | Name | Min | Max | Factory Setting | Unit | Data type | Effective | Can be changed |
|---|---|-------|------------|-----------------|------|-----------|-----------|----------------|
| p1115 | Ramp-function generator selection | 0 | 1 | 0 | - | I16 | IM | T |
| | Description: Sets the ramp-function generator type. | | | | | | | |
| | Note: Another ramp-function generator type can only be selected when the motor is at a standstill. | | | | | | | |
| p1120 | Ramp-function generator ramp-up time | 0.000 | 999999.000 | 1 | s | Float | IM | T, U |
| | Description: The ramp-function generator ramps-up the speed setpoint from standstill (setpoint = 0) up to the maximum speed (p1082) in this time. | | | | | | | |
| | Dependency: Refer to p1082 | | | | | | | |
| p1121 | Ramp-function generator ramp-down time | 0.000 | 999999.000 | 1 | s | Float | IM | T, U |
| | Description: Sets the ramp-down time for the ramp-function generator. The ramp-function generator ramps-down the speed setpoint from the maximum speed (p1082) down to standstill (setpoint = 0) in this time. Further, the ramp-down time is always effective for OFF1. | | | | | | | |
| | Dependency: Refer to p1082 | | | | | | | |
| p1130 | Ramp-function generator initial rounding-off time | 0.000 | 30.000 | 0.000 | s | Float | IM | T, U |
| | Description: Sets the initial rounding-off time for the extended ramp generator. The value applies to ramp-up and ramp-down. | | | | | | | |
| | Note: Rounding-off times avoid an abrupt response and prevent damage to the mechanical system. | | | | | | | |
| p1131 | Ramp-function generator final rounding-off time | 0.000 | 30.000 | 0.000 | s | Float | IM | T, U |
| | Description: Sets the final rounding-off time for the extended ramp generator. The value applies to ramp-up and ramp-down. | | | | | | | |
| | Note: Rounding-off times avoid an abrupt response and prevent damage to the mechanical system. | | | | | | | |
| p1215 * | Motor holding brake configuration | 0 | 3 | 0 | - | I16 | IM | T |
| | Description: Sets the holding brake configuration. | | | | | | | |
| | Dependency: Refer to p1216, p1217, p1226, p1227, p1228 | | | | | | | |
| | Caution: For the setting p1215 = 0, if a brake is used, it remains closed. If the motor moves, this will destroy the brake. | | | | | | | |
| | Notice: If p1215 was set to 1 or if p1215 was set to 3, then when the pulses are suppressed, the brake is closed even if the motor is still rotating. | | | | | | | |
| Note: If a holding brake integrated in the motor is used, then it is not permissible that p1215 is set to 3. The parameter can only be set to zero when the pulses are inhibited. | | | | | | | | |
| p1216 * | Motor holding brake opening time | 0 | 10000 | 100 | ms | Float | IM | T, U |
| | Description: Sets the time to open the motor holding brake. After controlling the holding brake (opens), the speed/velocity setpoint remains at zero for this time. After this, the speed/velocity setpoint is enabled. | | | | | | | |
| | Dependency: Refer to p1215, p1217 | | | | | | | |
| | Note: For a motor with integrated brake, this time is pre-assigned the value saved in the motor. For p1216 = 0 ms, the monitoring and the message A7931 "Brake does not open" are deactivated. | | | | | | | |

| Par. No. | Name | Min | Max | Factory Setting | Unit | Data type | Effective | Can be changed |
|----------|--|-------|-----------|-----------------|------|-----------|-----------|----------------|
| p1217 * | Motor holding brake closing time | 0 | 10000 | 100 | ms | Float | IM | T, U |
| | <p>Description: Sets the time to apply the motor holding brake. After OFF1 or OFF3 and the holding brake is controlled (the brake closes), then the drive remains closed-loop controlled for this time stationary with a speed setpoint/velocity setpoint of zero. The pulses are suppressed when the time expires.</p> | | | | | | | |
| | <p>Dependency: Refer to p1215, p1216</p> | | | | | | | |
| | <p>Note: For a motor with integrated brake, this time is pre-assigned the value saved in the motor. For p1217 = 0 ms, the monitoring and the message A07932 "Brake does not close" are deactivated.</p> | | | | | | | |
| p1226 | Threshold for zero speed detection | 0.00 | 210000.00 | 20.00 | rpm | Float | IM | T, U |
| | <p>Description: Sets the speed threshold for the standstill identification. Acts on the actual value and setpoint monitoring. When braking with OFF1 or OFF3, when the threshold is undershot, standstill is identified. The following applies when the brake control is activated: When the threshold is undershot, the brake control is started and the system waits for the brake closing time in p1217. The pulses are then suppressed. If the brake control is not activated, the following applies: When the threshold is undershot, the pulses are suppressed and the drive coasts down.</p> | | | | | | | |
| | <p>Dependency: Refer to p1215, p1216, p1217, p1227</p> | | | | | | | |
| | <p>Notice: For reasons relating to the compatibility to earlier firmware versions, a parameter value of zero in indices 1 to 31 is overwritten with the parameter value in index 0 when the drive boots.</p> | | | | | | | |
| | <p>Note: Standstill is identified in the following cases: - The speed actual value falls below the speed threshold in p1226 and the time started after this in p1228 has expired. - The speed setpoint falls below the speed threshold in p1226 and the time started after this in p1227 has expired. The actual value sensing is subject to measuring noise. For this reason, standstill cannot be detected if the speed threshold is too low.</p> | | | | | | | |
| | <p>Dependency: Refer to p1215, p1216, p1217, p1226</p> | | | | | | | |
| p1227 | Zero speed detection monitoring time | 0.000 | 300.000 | 300.000 | s | Float | IM | T, U |
| | <p>Description: Sets the monitoring time for the standstill identification. When braking with OFF1 or OFF3, standstill is identified after this time has expired, after the setpoint speed has fallen below p1226. After this, the brake control is started, the system waits for the closing time in p1217 and then the pulses are suppressed.</p> | | | | | | | |
| | <p>Dependency: Refer to p1215, p1216, p1217, p1226</p> | | | | | | | |
| | <p>Notice: The setpoint is not equal to zero dependent on the selected value. This can therefore cause the monitoring time in p1227 to be exceeded. In this case, for a driven motor, the pulses are not suppressed..</p> | | | | | | | |

| Par. No. | Name | Min | Max | Factory Setting | Unit | Data type | Effective | Can be changed |
|----------|--|----------|----------|-----------------|------|-----------|-----------|----------------|
| | <p>Note: Standstill is identified in the following cases:</p> <ul style="list-style-type: none"> - The speed actual value falls below the speed threshold in p1226 and the time started after this in p1228 has expired. - The speed setpoint falls below the speed threshold in p1226 and the time started after this in p1227 has expired. <p>For p1227 = 300.000 s, the following applies: Monitoring is de-activated.</p> <p>For p1227 = 0.000 s, the following applies: With OFF1 or OFF3 and a ramp-down time = 0, the pulses are immediately suppressed and the motor "coasts" down.</p> | | | | | | | |
| p1228 | Pulse suppression delay time | 0.000 | 299.000 | 0.000 | s | Float | IM | T, U |
| | <p>Description: Sets the delay time for pulse suppression. After OFF1 or OFF3, the pulses are canceled, if at least one of the following conditions is fulfilled:</p> <ul style="list-style-type: none"> - The speed actual value falls below the threshold in p1226 and the time started after this in p1228 has expired. - The speed setpoint falls below the threshold in p1226 and the time started after this in p1227 has expired. <p>Dependency: Refer to p1226, p1227</p> <p>Notice: When the motor holding brake is activated, pulse cancellation is additionally delayed by the brake closing time (p1217).</p> | | | | | | | |
| p1414 | Speed setpoint filter activation | 0000 bin | 0011 bin | 0000 bin | - | U16 | IM | T, U |
| | <p>Description: Setting for activating/de-activating the speed setpoint filter.</p> <p>Dependency: The individual speed setpoint filters are parameterized as of p1415.</p> <p>Note: The drive unit displays the value in hex format. To know the logic (high/low) assignment to each bit, you must convert the hex number to the binary number, for example, FF (hex) = 11111111 (bin).</p> | | | | | | | |
| p1415 | Speed setpoint filter 1 type | 0 | 2 | 0 | - | I16 | IM | T, U |
| | <p>Description: Sets the type for speed setpoint filter 1.</p> <p>Dependency: PT1 low pass: p1416 PT2 low pass: p1417, p1418 General filter: p1417 ... p1420</p> | | | | | | | |
| p1416 | Speed setpoint filter 1 time constant | 0.00 | 5000.00 | 0.00 | ms | Float | IM | T, U |
| | <p>Description: Sets the time constant for the speed setpoint filter 1 (PT1).</p> <p>Dependency: Refer to p1414, p1415</p> <p>Note: This parameter is only effective if the filter is set as a PT1 low pass.</p> | | | | | | | |
| p1417 | Speed setpoint filter 1 denominator natural frequency | 0.5 | 16000.0 | 1999.0 | Hz | Float | IM | T, U |
| | <p>Description: Sets the denominator natural frequency for speed setpoint filter 1(PT2, general filter).</p> <p>Dependency: Refer to p1414, p1415</p> <p>Note: This parameter is only effective if the speed filter is parameterized as a PT2 low pass or as general filter. The filter is only effective if the natural frequency is less than half of the sampling frequency.</p> | | | | | | | |

| Par. No. | Name | Min | Max | Factory Setting | Unit | Data type | Effective | Can be changed |
|----------|--|-------|---------|-----------------|------|-----------|-----------|----------------|
| p1418 | Speed setpoint filter 1 denominator damping | 0.001 | 10.000 | 0.700 | - | Float | IM | T, U |
| | Description: Sets the denominator damping for speed setpoint filter 1 (PT2, general filter). | | | | | | | |
| | Dependency: Refer to p1414, p1415 | | | | | | | |
| | Note: This parameter is only effective if the speed filter is parameterized as a PT2 low pass or as general filter. | | | | | | | |
| p1419 | Speed setpoint filter 1 numerator natural frequency | 0.5 | 16000.0 | 1999.0 | Hz | Float | IM | T, U |
| | Description: Sets the numerator natural frequency for speed setpoint filter 1 (general filter). | | | | | | | |
| | Dependency: Refer to p1414, p1415 | | | | | | | |
| | Note: This parameter is only effective if the speed filter is set as a general filter. The filter is only effective if the natural frequency is less than half of the sampling frequency. | | | | | | | |
| p1420 | Speed setpoint filter 1 numerator damping | 0.000 | 10.000 | 0.700 | - | Float | IM | T, U |
| | Description: Sets the numerator damping for speed setpoint filter 1 (general filter). | | | | | | | |
| | Dependency: Refer to p1414, p1415 | | | | | | | |
| | Note: This parameter is only effective if the speed filter is set as a general filter. | | | | | | | |
| p1421 | Speed setpoint filter 2 type | 0 | 2 | 0 | - | 16 | IM | T, U |
| | Description: Sets the type for speed setpoint filter 2. | | | | | | | |
| | Dependency: PT1 low pass: p1422 PT2 low pass: p1423, p1424 General filter: p1423 ... p1426 | | | | | | | |
| | | | | | | | | |
| p1422 | Speed setpoint filter 2 time constant | 0.00 | 5000.00 | 0.00 | ms | Float | IM | T, U |
| | Description: Sets the time constant for the speed setpoint filter 2 (PT1). | | | | | | | |
| | Dependency: Refer to p1414, p1421 | | | | | | | |
| | Note: This parameter is only effective if the speed filter is set as a PT1 low pass. | | | | | | | |
| p1423 | Speed setpoint filter 2 denominator natural frequency | 0.5 | 16000.0 | 1999.0 | Hz | Float | IM | T, U |
| | Description: Sets the denominator natural frequency for speed setpoint filter 2 (PT2, general filter). | | | | | | | |
| | Dependency: Refer to p1414, p1421 | | | | | | | |
| | Note: This parameter is only effective if the speed filter is parameterized as a PT2 low pass or as general filter. The filter is only effective if the natural frequency is less than half of the sampling frequency. | | | | | | | |
| p1424 | Speed setpoint filter 2 denominator damping | 0.001 | 10.000 | 0.700 | - | Float | IM | T, U |
| | Description: Sets the denominator damping for speed setpoint filter 2 (PT2, general filter). | | | | | | | |
| | Dependency: Refer to p1414, p1421 | | | | | | | |
| | Note: This parameter is only effective if the speed filter is parameterized as a PT2 low pass or as general filter. | | | | | | | |

10.2 Parameter list

| Par. No. | Name | Min | Max | Factory Setting | Unit | Data type | Effective | Can be changed |
|----------|---|--------------|-------------|-----------------|------|-----------|-----------|----------------|
| p1425 | Speed setpoint filter 2 numerator natural frequency | 0.5 | 16000.0 | 1999.0 | Hz | Float | IM | T, U |
| | Description: Sets the numerator natural frequency for speed setpoint filter 2 (general filter). | | | | | | | |
| | Dependency: Refer to p1414, p1421 | | | | | | | |
| | Note: This parameter is only effective if the speed filter is set as a general filter. The filter is only effective if the natural frequency is less than half of the sampling frequency. | | | | | | | |
| p1426 | Speed setpoint filter 2 numerator damping | 0.000 | 10.000 | 0.700 | - | Float | IM | T, U |
| | Description: Sets the numerator damping for speed setpoint filter 2 (general filter). | | | | | | | |
| | Dependency: Refer to p1414, p1421 | | | | | | | |
| | Note: This parameter is only effective if the speed filter is set as a general filter. | | | | | | | |
| p1520 * | Torque limit upper | -1000000.00 | 20000000.00 | 0.00 | Nm | Float | IM | T, U |
| | Description: Sets the fixed upper torque limit. | | | | | | | |
| | Danger: Negative values when setting the upper torque limit (p1520 < 0) can result in the motor accelerating in an uncontrollable fashion. | | | | | | | |
| | Notice: The maximum value depends on the maximum torque of the connected motor. | | | | | | | |
| p1521 * | Torque limit lower | -20000000.00 | 1000000.00 | 0.00 | Nm | Float | IM | T, U |
| | Description: Sets the fixed lower torque limit. | | | | | | | |
| | Danger: Positive values when setting the lower torque limit (p1521 > 0) can result in the motor accelerating in an uncontrollable fashion. | | | | | | | |
| | Notice: The maximum value depends on the maximum torque of the connected motor. | | | | | | | |
| p1656 * | Activates current setpoint filter | 0000 bin | 0011 bin | 0011 bin | - | U16 | IM | T, U |
| | Description: Setting for activating/de-activating the current setpoint filter. | | | | | | | |
| | Dependency: The individual current setpoint filters are parameterized as of p1657. | | | | | | | |
| | Note: If not all of the filters are required, then the filters should be used consecutively starting from filter 1. The drive unit displays the value in hex format. To know the logic (high/low) assignment to each bit, you must convert the hex number to the binary number, for example, FF (hex) = 11111111 (bin). | | | | | | | |
| p1657 * | Current setpoint filter 1 type | 1 | 2 | 1 | - | I16 | IM | T, U |
| | Description: Sets the current setpoint filter 1 as low pass (PT2) or general 2nd order filter. | | | | | | | |
| | Dependency: The current setpoint filter 1 is activated via p1656.0 and parameterized via p1657 ... p1661. | | | | | | | |
| | Note: For a general 2nd-order filter, by inserting the same natural frequency in both the numerator and in the denominator, i.e. bandstop frequency, a bandstop filter is implemented. If the numerator damping of zero is selected, the bandstop frequency is completely suppressed. The denominator damping can be determined from the equation for the 3 dB bandwidth: $f_{3dB \text{ bandwidth}} = 2 * D_{\text{denominator}} * f_{\text{bandstop frequency}}$ | | | | | | | |
| p1658 * | Current setpoint filter 1 denominator natural frequency | 0.5 | 16000.0 | 1000.0 | Hz | Float | IM | T, U |
| | Description: Sets the denominator natural frequency for current setpoint filter 1 (PT2, general filter). | | | | | | | |
| | Dependency: The current setpoint filter 1 is activated via p1656.0 and parameterized via p1657 ... p1661. | | | | | | | |

| Par. No. | Name | Min | Max | Factory Setting | Unit | Data type | Effective | Can be changed |
|----------|---|-------|---------|-----------------|------|-----------|-----------|----------------|
| p1659 * | Current setpoint filter 1 denominator damping | 0.001 | 10.000 | 0.700 | - | Float | IM | T, U |
| | Description: Sets the denominator damping for current setpoint filter 1. | | | | | | | |
| | Dependency: The current setpoint filter 1 is activated via p1656.0 and parameterized via p1657 ... p1661. | | | | | | | |
| p1660 | Current setpoint filter 1 numerator natural frequency | 0.5 | 16000.0 | 1000.0 | Hz | Float | IM | T, U |
| | Description: Sets the numerator natural frequency for current setpoint filter 1 (general filter). | | | | | | | |
| | Dependency: The current setpoint filter 1 is activated via p1656.0 and parameterized via p1657 ... p1661. | | | | | | | |
| p1661 | Current setpoint filter 1 numerator damping | 0.000 | 10.000 | 0.700 | - | Float | IM | T, U |
| | Description: Sets the numerator damping for current setpoint filter 1. | | | | | | | |
| | Dependency: The current setpoint filter 1 is activated via p1656.0 and parameterized via p1657 ... p1661. | | | | | | | |
| p1662 | Current setpoint filter 2 type | 1 | 2 | 2 | - | 116 | IM | T, U |
| | Description: Sets the current setpoint filter 2 as low pass (PT2) or general 2nd order filter. | | | | | | | |
| | Dependency: Current setpoint filter 2 is activated via p1656.1 and parameterized via p1662 ... p1666. | | | | | | | |
| | <p>Note: For a general 2nd-order filter, by inserting the same natural frequency in both the numerator and in the denominator, i.e. bandstop frequency, a bandstop filter is implemented. If the numerator damping of zero is selected, the bandstop frequency is completely suppressed.</p> <p>The denominator damping can be determined from the equation for the 3 dB bandwidth: $f_{3dB} \text{ bandwidth} = 2 * D_{denominator} * f_{bandstop} \text{ frequency}$</p> | | | | | | | |
| p1663 | Current setpoint filter 2 denominator natural frequency | 0.5 | 16000.0 | 500.0 | Hz | Float | IM | T, U |
| | Description: Sets the denominator natural frequency for current setpoint filter 2 (PT2, general filter). | | | | | | | |
| | Dependency: Current setpoint filter 2 is activated via p1656.1 and parameterized via p1662 ... p1666. | | | | | | | |
| p1664 | Current setpoint filter 2 denominator damping | 0.001 | 10.000 | 0.300 | - | Float | IM | T, U |
| | Description: Sets the denominator damping for current setpoint filter 2. | | | | | | | |
| | Dependency: Current setpoint filter 2 is activated via p1656.1 and parameterized via p1662 ... p1666. | | | | | | | |
| p1665 | Current setpoint filter 2 numerator natural frequency | 0.5 | 16000.0 | 500.0 | Hz | Float | IM | T, U |
| | Description: Sets the numerator natural frequency for current setpoint filter 2 (general filter). | | | | | | | |
| | Dependency: Current setpoint filter 2 is activated via p1656.1 and parameterized via p1662 ... p1666. | | | | | | | |
| p1666 | Current setpoint filter 2 numerator damping | 0.000 | 10.000 | 0.010 | - | Float | IM | T, U |
| | Description: Sets the numerator damping for current setpoint filter 2. | | | | | | | |
| | Dependency: Current setpoint filter 2 is activated via p1656.1 and parameterized via p1662 ... p1666. | | | | | | | |
| p2153 | Speed actual value filter time constant | 0 | 1000000 | 0 | ms | Float | IM | T, U |
| | <p>Description: Sets the time constant of the PT1 element to smooth the speed / velocity actual value.</p> <p>The smoothed actual speed/velocity is compared with the threshold values and is only used for messages and signals.</p> | | | | | | | |

| Par. No. | Name | Min | Max | Factory Setting | Unit | Data type | Effective | Can be changed |
|---|---|------|----------------|-----------------|------|-----------|-----------|----------------|
| p2161 * | Speed threshold 3 | 0.00 | 210000.00 | 10.00 | rpm | Float | IM | T, U |
| Description: Sets the speed threshold value for the signal " $ n_{act} < \text{speed threshold value } 3$ ". | | | | | | | | |
| p2162 * | Hysteresis speed $n_{act} > n_{max}$ | 0.00 | 60000.00 | 0.00 | rpm | Float | IM | T, U |
| Description: Sets the hysteresis speed (bandwidth) for the signal " $n_{act} > n_{max}$ ". | | | | | | | | |
| Note: For a negative speed limit, the hysteresis is effective below the limit value and for a positive speed limit above the limit value. If significant overshoot occurs in the maximum speed range (for example, due to load shedding), you are advised to increase the dynamic response of the speed controller (if possible). If this is insufficient, the hysteresis p2162 can only be increased by more than 10% of the rated speed when the maximum speed of the motor is sufficiently greater than the speed limit p1082. The range of the parameter is different when connect with different motors. | | | | | | | | |
| p2525 | LR encoder adjustment offset | 0 | 429496729 5 | 0 | LU | U32 | IM | T |
| Description: For the absolute encoder adjustment, a drive determines the position offset. | | | | | | | | |
| Note: The position offset is only relevant for absolute encoders. The drive determines it when making the adjustment and the user should not change it. | | | | | | | | |
| p2533 | LR position setpoint filter time constant | 0.00 | 1000.00 | 0.00 | ms | Float | IM | T, U |
| Description: Sets the time constant for the position setpoint filter (PT1). | | | | | | | | |
| Note: The effective Kv factor (position loop gain) is reduced with the filter. This allows a softer control behavior with improved tolerance with respect to noise/disturbances. Applications: - Reduces the pre-control dynamic response. - Jerk limiting. | | | | | | | | |
| p2542 * | LR standstill window | 0 | 214748364 7 | 1000 | LU | U32 | IM | T, U |
| Description: Sets the standstill window for the standstill monitoring function. After the standstill monitoring time expires, it is cyclically checked whether the difference between the setpoint and actual position is located within the standstill window and, if required, an appropriate fault is output. Value = 0: The standstill monitoring is deactivated. | | | | | | | | |
| Dependency: Refer to: p2543, p2544, and F07450 | | | | | | | | |
| Note: The following applies for the setting of the standstill and positioning window: Standstill window (p2542) \geq positioning window (p2544) | | | | | | | | |
| p2543 * | LR standstill monitoring time | 0.00 | 100000.00 | 200.00 | ms | Float | IM | T, U |
| Description: Sets the standstill monitoring time for the standstill monitoring function. After the standstill monitoring time expires, it is cyclically checked whether the difference between the setpoint and actual position is located within the standstill window and, if required, an appropriate fault is output. | | | | | | | | |
| Dependency: Refer to: p2542, p2545, and F07450 | | | | | | | | |
| Note: The following applies for the setting of the standstill and positioning monitoring time: Standstill monitoring time (p2543) \leq positioning monitoring time (p2545) | | | | | | | | |

| Par. No. | Name | Min | Max | Factory Setting | Unit | Data type | Effective | Can be changed |
|----------|---|------|------------|-----------------|-------------------------------|-----------|-----------|----------------|
| p2544 * | LR positioning window | 0 | 2147483647 | 40 | LU | U32 | IM | T, U |
| | <p>Description: Sets the positioning window for the positioning monitoring function. After the positioning monitoring time expires, it is checked once as to whether the difference between the setpoint and actual position lies within the positioning window and if required an appropriate fault is output. Value = 0 --> The positioning monitoring function is de-activated.</p> | | | | | | | |
| | <p>Dependency: Refer to F07451.</p> | | | | | | | |
| | <p>Note: The following applies for the setting of the standstill and positioning window: Standstill window (p2542) \geq positioning window (p2544)</p> | | | | | | | |
| p2545 * | LR positioning monitoring time | 0.00 | 100000.00 | 1000.00 | ms | Float | IM | T, U |
| | <p>Description: Sets the positioning monitoring time for the positioning monitoring. After the positioning monitoring time expires, it is checked once as to whether the difference between the setpoint and actual position lies within the positioning window and if required an appropriate fault is output.</p> | | | | | | | |
| | <p>Dependency: The range of p2545 depends on p2543. Refer to: p2543, p2544, F07451</p> | | | | | | | |
| | <p>Note: The tolerance bandwidth is intended to prevent the dynamic following error monitoring incorrectly responding due to operational control sequences (for example, during load surges).</p> | | | | | | | |
| p2546 * | LR dynamic following error monitoring tolerance | 0 | 2147483647 | 1000 | LU | U32 | IM | T, U |
| | <p>Description: Sets the tolerance for the dynamic following error monitoring. If the dynamic following error (r2563) exceeds the selected tolerance, then an appropriate fault is output. Value = 0 --> The dynamic following error monitoring is de-activated.</p> | | | | | | | |
| | <p>Dependency: Refer to r2563, F07452</p> | | | | | | | |
| | <p>Note: The tolerance bandwidth is intended to prevent the dynamic following error monitoring incorrectly responding due to operational control sequences (e.g. during load surges).</p> | | | | | | | |
| p2572 ** | IPOS maximum acceleration | 1 | 2000000 | Motor dependent | 100 0 LU/s ² | U32 | IM | T |
| | <p>Description: Sets the maximum acceleration for the "basic positioner" function (IPOS).</p> | | | | | | | |
| | <p>Note: The maximum acceleration appears to exhibit jumps (without jerk). "Traversing blocks" operating mode: The programmed acceleration override acts on the maximum acceleration. "Direct setpoint input/MDI" mode: The acceleration override is effective. "Jog" and "search for reference" modes: No acceleration override is active. The axis starts with the maximum acceleration.</p> | | | | | | | |
| p2573 ** | IPOS maximum deceleration | 1 | 2000000 | Motor dependent | 100 0 LU/s ² | U32 | IM | T |
| | <p>Description: Sets the maximum deceleration for the "basic positioner" function (IPOS).</p> | | | | | | | |

10.2 Parameter list

| Par. No. | Name | Min | Max | Factory Setting | Unit | Data type | Effective | Can be changed |
|----------|--|-------------|------------|-----------------|------|------------|-----------|----------------|
| | <p>Note: The maximum deceleration appears to exhibit jumps (without jerk). "Traversing blocks" operating mode: The programmed deceleration override acts on the maximum deceleration. "Direct setpoint input/MDI" mode: The deceleration override is effective. "Jog" and "search for reference" modes: No deceleration override is effective. The axis brakes with the maximum deceleration.</p> | | | | | | | |
| p2580 | EPOS software limit switch minus | -2147482648 | 2147482647 | - 2147482648 | LU | I32 | IM | T, U |
| | Description: Sets the software limit switch in the negative direction of travel. | | | | | | | |
| | Dependency: Refer to p2581, p2582 | | | | | | | |
| p2581 | EPOS software limit switch plus | -2147482648 | 2147482647 | 2147482647 | LU | I32 | IM | T, U |
| | Description: Sets the software limit switch in the positive direction of travel. | | | | | | | |
| | Dependency: Refer to p2580, p2582 | | | | | | | |
| p2582 | EPOS software limit switch activation | - | - | 0 | - | U32/Binary | IM | T |
| | Description: Sets the signal source to activate the "software limit switch". | | | | | | | |
| | Dependency: Refer to p2580, p2581 | | | | | | | |
| | <p>Caution: Software limit switch effective: - Axis is referenced. Software limit switch ineffective: - Modulo correction active. - Search for reference is executed.</p> | | | | | | | |
| | <p>Note: Target position for relative positioning outside software limit switch: The traversing block is started and the axis comes to a standstill at the software limit switch. An appropriate alarm is output and the traversing block is interrupted. Traversing blocks with valid position can be activated. Target position for absolute positioning outside software limit switch: In the "traversing blocks" mode, the traversing block is not started and an appropriate fault is output. Axis outside the valid traversing range: If the axis is already outside the valid traversing range, then an appropriate fault is output. The fault can be acknowledged at standstill. Traversing blocks with valid position can be activated.</p> | | | | | | | |
| | Note: The traversing range can also be limited using STOP cams. | | | | | | | |
| p2583 | EPOS backlash compensation | -200000 | 200000 | 0 | LU | I32 | - | T, U |
| | <p>Description: Sets the amount of play (backlash) for positive or negative play.</p> <ul style="list-style-type: none"> • = 0: The backlash compensation is de-activated. • > 0: Positive backlash (normal case) When the direction is reversed, the encoder actual value leads the actual value. • < 0: Negative backlash When the direction is reversed, the actual value leads the encoder actual value. | | | | | | | |

| Par. No. | Name | Min | Max | Factory Setting | Unit | Data type | Effective | Can be changed |
|----------|---|-------------|------------|-----------------|-------------|------------|-----------|----------------|
| | <p>Dependency: If a stationary axis is referenced by setting the reference point, or an adjusted with absolute encoder is powered up, then the setting of p2604 is relevant for entering the compensation value.</p> <p>p2604 = 1: Traveling in the positive direction -> A compensation value is immediately entered. Traveling in the negative direction -> A compensation value is not entered</p> <p>p2604 = 0: Traveling in the positive direction -> A compensation value is not entered Traveling in the negative direction -> A compensation value is immediately entered.</p> <p>When again setting the reference point (a referenced axis) or for "flying referencing", p2604 is not relevant but instead the history of the axis.</p> <p>Refer to p2604</p> | | | | | | | |
| p2599 | EPOS reference point coordinate value | -2147482648 | 2147482647 | 0 | LU | I32 | IM | T, U |
| | <p>Description: Sets the position value for the reference point coordinate. This value is set as the actual axis position after referencing or adjustment.</p> <p>Dependency: Refer to p2525</p> | | | | | | | |
| p2600 | EPOS search for reference point offset | -2147482648 | 2147482647 | 0 | LU | I32 | IM | T, U |
| | <p>Description: Sets the reference point offset for search for reference.</p> | | | | | | | |
| p2604 | EPOS search for reference start direction | - | - | 0 | - | U32/Binary | IM | T |
| | <p>Description: Sets the signal sources for the start direction of the search for reference.</p> <ul style="list-style-type: none"> • 1 signal: Start in the negative direction. • 0 signal: Start in the positive direction. <p>Dependency: Refer to p2583</p> | | | | | | | |
| p2605 | EPOS search for reference approach velocity reference cam | 1 | 40000000 | 5000 | 1000 LU/min | U32 | IM | T, U |
| | <p>Description: Sets the approach velocity to the reference cam for the search for reference.</p> <p>Dependency: The search for reference only starts with the approach velocity to the reference cam when there is a reference cam.</p> <p>Refer to p2604, p2606</p> <p>Note: When traversing to the reference cam, the velocity override is effective. If, at the start of the search for reference, the axis is already at the reference cam, then the axis immediately starts to traverse to the zero mark.</p> | | | | | | | |
| p2606 | EPOS search for reference reference cam maximum distance | 0 | 2147482647 | 2147482647 | LU | U32 | IM | T, U |
| | <p>Description: Sets the maximum distance after the start of the search for reference when traversing to the reference cam.</p> <p>Dependency: Refer to p2604, p2605, F07458</p> <p>Note: When using a reversing cam, the maximum distance must be set appropriately long.</p> | | | | | | | |

10.2 Parameter list

| Par. No. | Name | Min | Max | Factory Setting | Unit | Data type | Effective | Can be changed |
|----------|--|-------------|----------------|-----------------|------------------------|-----------|-----------|----------------|
| p2608 | EPOS search for reference approach velocity zero mark | 1 | 40000000 | 300 | 100 0 LU/ min | U32 | IM | T, U |
| | Description: Sets the approach velocity after detecting the reference cam to search for the zero mark for the search for reference. | | | | | | | |
| | Dependency: If there is no reference cam, the search for reference immediately starts with the axis traversing to the zero mark. Refer to p2604, p2609 | | | | | | | |
| | Caution: If the reference cam is not adjusted so that at each search for reference the same zero mark for synchronization is detected, then an "incorrect" axis reference point is obtained. After the reference cam has been left, the search for the zero mark is activated with a time delay due to internal factors. This is the reason that the reference cam should be adjusted in this center between two zero marks and the approach velocity should be adapted to the distance between two zero marks. Note: The velocity override is not effective when traversing to the zero mark. | | | | | | | |
| p2609 | EPOS search for reference max. distance ref. cam and zero mark | 0 | 214748264 7 | 20000 | LU | U32 | IM | T, U |
| | Description: Sets the maximum distance after leaving the reference cam when traversing to the zero mark. Dependency: Refer to p2604, p2608, F07459 | | | | | | | |
| p2611 | EPOS search for reference approach velocity reference point | 1 | 40000000 | 300 | 100 0 LU/ min | U32 | IM | T, U |
| | Description: Sets the approach velocity after detecting the zero mark to approach the reference point. | | | | | | | |
| | Dependency: Refer to p2604, p2609 Note: When traversing to the reference point, the velocity override is not effective. | | | | | | | |
| p2617 | EPOS traversing block position | -2147482648 | 214748264 7 | 0 | LU | I32 | IM | T, U |
| | Description: Sets the target position for the traversing block. | | | | | | | |
| | Dependency: Refer to p2618 Note: The target position is approached in either relative or absolute terms depending on p29241. | | | | | | | |
| p2618 | EPOS traversing block velocity | 1 | 40000000 | 600 | 100 0 LU/ min | I32 | IM | T, U |
| | Description: Sets the velocity for the traversing block. | | | | | | | |
| | Dependency: The number of indices depends on p2615. Refer to p2617 Note: The velocity can be influenced using the velocity override (p2646). | | | | | | | |
| p29000 * | Motor ID | 0 | 54251 | 0 | - | U16 | RE | T |
| | Description: Motor type number is printed on the motor rating plate as motor ID. For a motor with an incremental encoder, users need to manually input the parameter value, ranging from 18 to 39. For a motor with an absolute encoder, the drive automatically reads the parameter value, ranging from 10009 to 10048. | | | | | | | |

| Par. No. | Name | Min | Max | Factory Setting | Unit | Data type | Effective | Can be changed |
|----------|---|-----|-----|-----------------|------|-----------|-----------|----------------|
| p29001 | Reversal of motor direction | 0 | 1 | 0 | - | I16 | RE | T |
| | <p>Description: Reversal of motor running direction. By default, CW is the positive direction while CCW the negative direction. After changing of p29001, reference point will lost, A7461 will remind user to referencing again.</p> <ul style="list-style-type: none"> • 0: No reversal • 1: Reverse | | | | | | | |
| p29002 | BOP display selection | 0 | 4 | 0 | - | I16 | IM | U |
| | <p>Description: Selection of BOP operating display.</p> <ul style="list-style-type: none"> • 0: Actual speed (default) • 1: DC voltage • 2: Actual torque • 3: Actual position • 4: Position offset | | | | | | | |
| p29003 | Control mode | 0 | 8 | 0 | - | I16 | RE | T |
| | <p>Description: Selection of control mode.</p> <ul style="list-style-type: none"> • 0: Position control with pulse train input (PTI) • 1: Internal position control (IPos) • 2: Speed control (S) • 3: Torque control (T) • 4: Control change mode: PTI/S • 5: Control change mode: IPos/S • 6: Control change mode: PTI/T • 7: Control change mode: IPos/T • 8: Control change mode: S/T | | | | | | | |
| | <p>Note: The compound control mode can be controlled by the digital input signal C-MODE. When DI10 (C-MODE) is 0, the first control mode of control change mode is selected; otherwise, the second one is selected.</p> | | | | | | | |
| p29004 | RS485 address | 0 | 31 | 0 | - | U16 | RE | T |
| | <p>Description: Configuration of the RS485 bus address. The RS485 bus is used to transfer current absolute position of the servo drive to the controller/PLC.</p> | | | | | | | |
| p29005 | Braking resistor capacity percentage alarm threshold | 1 | 100 | 100 | % | Float | - | T |
| | <p>Description: Alarm triggering threshold for the capacity of the internal braking resistor. Alarm number: A52901</p> | | | | | | | |
| p29006 | Line supply voltage | 380 | 480 | [0] 400 | V | U16 | IM | T |
| | <p>Description: Nominal Line supply voltage, effective value of line to line voltage. Drive can operate within -15% to +10% error.</p> | | | | | | | |

10.2 Parameter list

| Par. No. | Name | Min | Max | Factory Setting | Unit | Data type | Effective | Can be changed |
|---|---|------|----------|-----------------|------|-----------|-----------|----------------|
| p29010 | PTI: Selection of input pulse form | 0 | 3 | 0 | - | I16 | RE | T |
| <p>Description: Selection of setpoint pulse train input form. After changing of p29010, reference point will lost, A7461 will remind user to referencing again.</p> <ul style="list-style-type: none"> 0: Pulse + direction, positive logic 1: AB phase, positive logic 2: Pulse + direction, negative logic 3: AB phase, negative logic | | | | | | | | |
| p29011 | PTI: Number of Setpoint Pulse Per Revolution | 0 | 16777215 | 0 | - | U32 | IM | T |
| <p>Description: The number of setpoint pulses per motor revolution. The servo motor rotates for one revolution when the number of the setpoint pulses reaches this value.</p> <p>When this value is 0, the number of required setpoint pulses is decided by the electronic gear ratio.</p> | | | | | | | | |
| p29012[0..3] | PTI: Numerator of Electronic Gear | 1 | 10000 | 1 | - | U32 | IM | T |
| <p>Description: The numerator of the electronic gear ratio for the setpoint pulses. For the servo system with an absolute encoder, the value range of p29012 is 1 to 10000.</p> <p>Four numerators in total are available. You can select one of the numerators by configuring the digital input signal EGEAR.</p> <p>For detailed information about the calculation of a numerator, refer to the SINAMICS V90 Operating Instructions or use SINAMICS V-ASSISTANT to do the calculation.</p> | | | | | | | | |
| p29013 | PTI: Denominator of Electronic Gear | 1 | 10000 | 1 | - | U32 | IM | T |
| <p>Description: The denominator of the electronic gear for the setpoint pulses.</p> | | | | | | | | |
| p29014 | PTI: Selection of Pulse input Electrical Level | 0 | 1 | 1 | - | I16 | IM | T |
| <p>Description: Selection of a logic level for the setpoint pulses.</p> <ul style="list-style-type: none"> 0: 5 V 1: 24 V | | | | | | | | |
| p29016 | PTI: Pulse Input Filter | 0 | 1 | [0] 0 | - | I16 | IM | T |
| <p>Description: Select filter for PTI input to get better EMC performance, 0 for low frequency PTI input, 1 for high frequency PTI input.</p> | | | | | | | | |
| p29020 | Tuning: Response Level | 1 | 31 | 16 | - | U16 | IM | T |
| <p>Description: The dynamic factor of auto tuning. 31 dynamic factors in total are available.</p> | | | | | | | | |
| p29021 | Tuning: Mode Selection | 0 | 5 | 0 | - | U16 | IM | T |
| <p>Description: Selection of a tuning mode.</p> <ul style="list-style-type: none"> 0: Disabled 3: Real-time tuning for positioning 4: Real-time tuning for interpolation 5: Disable with default controller parameters | | | | | | | | |
| p29022 | Tuning: Ratio of Total Inertia Moment to Motor Inertia Moment | 1.00 | 10000.00 | 1.00 | - | Float | IM | T, U |
| <p>Description: Ratio of total inertia moment to servo motor inertia moment.</p> | | | | | | | | |

| Par. No. | Name | Min | Max | Factory Setting | Unit | Data type | Effective | Can be changed |
|--------------|---|-------|--------------------|--------------------|------|-----------|-----------|----------------|
| p29023 | Resonance suppression enable | 0 | 2 | 0 | - | I16 | IM | T, U |
| | <p>Description: Activation of resonance suppression.</p> <ul style="list-style-type: none"> 0: Resonance suppression deactivated (manual input of resonance frequency) 1: Real-time resonance suppression 2: One-time resonance frequency search with excitation | | | | | | | |
| p29025 | Tuning start | 0 | 63 | 13 | - | U16 | IM | T, U |
| | <p>Description: The configuration of auto tuning.</p> <p>Note:</p> <ul style="list-style-type: none"> Bit 0: For significant differences between the motor and load moment of inertia, or for low dynamic performance of the controller, then the P controller becomes a PD controller in the position control loop. As a consequence, the dynamic performance of the position controller is increased. This function should only be set when the speed pre-control (bit 3 = 1) or the torque pre-control (bit 4 = 1) is active. Bit 1: At low speeds, the controller gain factors are automatically reduced in order to avoid noise and oscillation at standstill. This setting is recommended for incremental encoders. Bit 2: The estimated load moment of inertia is taken into account for the speed controller gain. Bit 3: Activates the speed pre-control for the position controller. Bit 4: Activates the torque pre-control for the position controller. Bit 5: Adapts acceleration limit. | | | | | | | |
| p29028 | Auto tuning pre-control time constant | 0.0 | 60.0 | 7.5 | ms | Float | IM | T, U |
| | <p>Description: Sets the time constant for the pre-control symmetrization for auto tuning. As a consequence, the drive is allocated a defined, dynamic response via its pre-control. For drives, which must interpolate with one another, the same value must be entered. The higher this time constant is, the smoother the drive will follow the position set point.</p> <p>Note: This time constant is only effective if p29021 = 4.</p> | | | | | | | |
| p29030 | PTO: Number of pulse per revolution | 0, 30 | 16384 | 1000 | - | U32 | IM | T |
| | <p>Description: Number of output pulses per motor revolution. If this value is 0, the number of required output pulses is decided by the electronic gear ratio.</p> | | | | | | | |
| p29031 | PTO: Numerator of electronic gear | 1 | 214700000 0 | 1 | - | U32 | IM | T |
| | <p>Description: The numerator of the electronic gear ratio for the output pulses. For detailed information about the calculation of the numerator, refer to SINAMICS V90 Operating Instructions or use the SINAMICS V-ASSISTANT to do the calculation.</p> | | | | | | | |
| p29032 | PTO: Denominator electronic gear | 1 | 214700000 0 | 1 | - | U32 | IM | T |
| | <p>Description: The denominator of the electronic gear ratio for the output pulses. For detailed information about the calculation of the denominator, refer to SINAMICS V90 Operating Instructions or use the SINAMICS V-ASSISTANT to do the calculation.</p> | | | | | | | |
| p29041[0..1] | Torque Scaling | 0 | [0] 100 [1] 300 | [0] 100 [1] 300 | % | Float | IM | T |

10.2 Parameter list

| Par. No. | Name | Min | Max | Factory Setting | Unit | Data type | Effective | Can be changed |
|----------------|--|---------|--------|-----------------|------|-----------|-----------|----------------|
| | Description: <ul style="list-style-type: none"> [0]The scaling for the analog torque setpoint. With this parameter, you can specify the torque setpoint corresponding to full analog input (10 V). [1]The scaling for the analog torque limit. With this parameter, you can specify the torque limit corresponding to full analog input (10 V). You can select the internal parameters or the analog input as the source of the torque limit with the combination of the digital input signals TLIM1 and TLIM2. Index: [0]: TORQUESETSCALE [1]: TORQUELIMITSCALE | | | | | | | |
| p29042 | Offset Adjustment for Analog input 2 | -0.50 | 0.50 | 0.00 | V | Float | IM | T |
| | Description: Offset adjustment for the analog input 2. | | | | | | | |
| p29043 | Fixed Torque Setpoint | -100 | 100 | 0 | % | Float | IM | T |
| | Description: Fixed torque setpoint. You can select the internal parameters or the analog input as the source of the torque setpoint by configuring the digital input signal TSET. | | | | | | | |
| p29050[0..2] | Torque limit upper | -150 | 300 | 300 | % | Float | IM | T |
| | Description: Positive torque limit. Three internal torque limits in total are available. You can select the internal parameters or the analog input as the source of the torque limit with the combination of the digital input signals TLIM1 and TLIM2. | | | | | | | |
| p29051[0..2] | Torque limit lower | -300 | 150 | -300 | % | Float | IM | T |
| | Description: Negative torque limit. Three internal torque limits in total are available. You can select the internal parameters or the analog input as the source of the torque limit with the combination of the digital input signals TLIM1 and TLIM2. | | | | | | | |
| p29060 * | Speed Scaling | 6 | 210000 | 3000 | rpm | Float | IM | T |
| | Description: The scaling for the analog speed setpoint. With this parameter, you can specify the speed setpoint corresponding to full analog input (10 V). | | | | | | | |
| p29061 | Offset Adjustment for Analog input 1 | -0.50 | 0.50 | 0.00 | V | Float | IM | T |
| | Description: Offset adjustment for the analog input 1. | | | | | | | |
| p29070[0..2] * | Speed limit positive | 0 | 210000 | [0] 210000 | rpm | Float | IM | T |
| | Description: Positive speed limit. Three internal speed limits in total are available. You can select the internal parameters or the analog input as the source of the speed limit with the combination of the digital input signals SLIM1 and SLIM2. | | | | | | | |
| p29071[0..2] * | Speed limit negative | -210000 | 0 | [0] - 210000 | rpm | Float | IM | T |
| | Description: Negative speed limit. Three internal speed limits in total are available. You can select the internal parameters or the analog input as the source of the speed limit with the combination of the digital input signals SLIM1 and SLIM2. | | | | | | | |

| Par. No. | Name | Min | Max | Factory Setting | Unit | Data type | Effective | Can be changed |
|-----------------|--|-------|-----------|----------------------------------|----------|-----------|-----------|----------------|
| p29075 | Speed Clamp Threshold | 0 | 200 | 200 | rpm | Float | IM | T |
| | Description: The threshold for the zero speed clamp. If the function of zero speed clamp has been enabled under the speed control mode, the motor speed is clamped to 0 when both the setpoint speed and the actual speed are below this threshold. | | | | | | | |
| p29078 | Speed Reach Threshold | 0.0 | 100.0 | 10 | rpm | Float | IM | T |
| | Description: Speed reached range (deviation between setpoint and motor speed) | | | | | | | |
| p29080 | Overload Threshold for Output Signal Triggering | 10 | 300 | 100 | % | Float | IM | T |
| | Description: Overload threshold for the output power. | | | | | | | |
| p29090 | Offset Adjustment for Analog output 1 | -0.50 | 0.50 | 0.00 | V | Float | IM | T |
| | Description: Offset adjustment for analog output 1. | | | | | | | |
| p29091 | Offset Adjustment for Analog output 2 | -0.50 | 0.50 | 0.00 | V | Float | IM | T |
| | Description: Offset adjustment for analog output 2. | | | | | | | |
| p29110[0..1] ** | Position Loop Gain | 0.000 | 300.000 | [0] Motor dependent [1] 1.000 | 1000/min | Float | IM | T, U |
| | Description: Position loop gain. Two position loop gains in total are available. You can switch between these two gains by configuring the digital input signal G-CHANGE or setting relevant condition parameters. The first position loop gain is the default setting. | | | | | | | |
| p29111 | Speed Pre-control Factor (Feed Forward) | 0.00 | 200.00 | 0.00 | % | Float | IM | T, U |
| | Description: Setting to activate and weight the speed pre-control value. Value = 0 % --> The pre-control is deactivated. | | | | | | | |
| p29120[0..1] ** | Speed Loop Gain | 0.00 | 999999.00 | [0] Motor dependent [1] 0.30 | Nms/rad | Float | IM | T, U |
| | Description: Speed loop gain. Two speed loop gains in total are available. You can switch between these two gains by configuring the digital input signal G-CHANGE or setting relevant condition parameters. The first speed loop gain is the default setting. | | | | | | | |
| p29121[0..1] * | Speed Loop Integral time | 0.00 | 100000.00 | [0] 15 [1] 20 | ms | Float | IM | T, U |
| | Description: Speed loop integral time. Two speed loop integral time values in total are available. You can switch between these two time values by configuring the digital input signal G-CHANGE or setting relevant condition parameters. The first speed loop integral time is the default setting. | | | | | | | |
| p29130 | Gain Switching: Mode Selection | 0 | 4 | 0 | - | 116 | IM | T |

| Par. No. | Name | Min | Max | Factory Setting | Unit | Data type | Effective | Can be changed |
|----------|---|-----|------------|-----------------|-------------|-----------|-----------|----------------|
| | <p>Description: Selects gain switching mode.</p> <ul style="list-style-type: none"> 0: Disabled 1: Switch through DI-G-CHANG 2: Position deviation as switch condition 3: Pulse input frequency as switch condition 4: Actual speed as switch condition <p>Note: Only when the auto tuning function (p20021=0) is disabled can the gain switching function be used.</p> | | | | | | | |
| p29131 | Gain Switching Condition: Pulse Deviation | 0 | 2147483647 | 100 | LU | I32 | IM | T |
| | <p>Description: Triggers position deviation threshold for gain switching. If the gain switching function is enabled and this condition is selected:</p> <ul style="list-style-type: none"> Switch from the first group of control parameters to the second group when the position deviation is larger than the threshold. Switch from the second group of control parameters to the first group when the position deviation is smaller than the threshold. | | | | | | | |
| p29132 | Gain Switching Condition: Position Setpoint Frequency | 0 | 2147000064 | 100 | 1000 LU/min | Float | IM | T |
| | <p>Description: Triggers pulse input frequency (PTI) threshold or internal position speed (IPos) threshold for gain switching. If the gain switching function is enabled and this condition is selected:</p> <ol style="list-style-type: none"> PTI <ul style="list-style-type: none"> Switch from the first group of control parameters to the second group when the pulse train input pulse is higher than the threshold. Switch from the second group of control parameters to the first group when the pulse train input is lower than the threshold. IPos <ul style="list-style-type: none"> Switch from the first group of control parameters to the second group when the speed of fixed position setpoint is larger than the threshold. Switch from the second group of control parameters to the first group when the IPos is smaller than the threshold. | | | | | | | |
| p29133 | Gain Switching Condition: Actual Speed | 0 | 2147000064 | 100 | rpm | Float | IM | T |
| | <p>Description: Triggers speed threshold for gain switching. If the gain switching function is enabled and this condition is selected:</p> <ul style="list-style-type: none"> Switch from the first group of control parameters to the second group when the actual motor speed is larger than the threshold. Switch from the second group of control parameters to the first group when the actual motor speed is smaller than the threshold. | | | | | | | |
| p29139 | Gain switching Time Constant | 8 | 1000 | 20 | ms | Float | IM | T |
| | <p>Description: Time constant for gain switching. Set this parameter to avoid frequent gain switches that reduces system reliability.</p> | | | | | | | |

| Par. No. | Name | Min | Max | Factory Setting | Unit | Data type | Effective | Can be changed |
|----------|--|-----|------------|-----------------|--------------------|-----------|-----------|----------------|
| p29140 | PI to P: Mode Selection | 0 | 5 | 0 | - | U16 | IM | T |
| | <p>Description: Selects a condition for the switch from PI control to P control under the speed loop.</p> <ul style="list-style-type: none"> 0: Disabled 1: Torque is higher than a parameterizable setting value. 2: Using the digital input signal (G-CHANGE). 3: Speed is higher than a parameterizable setting value. 4: Acceleration is higher than a parameterizable setting value. 5: Pulse deviation is higher than a parameterizable setting value. <p>Note: Only when the auto tuning function (p29021=0) and gain switching function are both disabled can the PI/P switching function be used.</p> | | | | | | | |
| p29141 | PI to P Switching Condition: Torque | 0 | 300 | 200 | % | Float | IM | T |
| | <p>Description: Triggers torque threshold for PI/P switching. If the PI/P switching function is enabled and this condition is selected:</p> <ul style="list-style-type: none"> Switch from the PI control to the P control when the actual torque is larger than the threshold. Switch from the P control to the PI control when the actual torque is smaller than the threshold. | | | | | | | |
| p29142 | PI to P Switching Condition: Speed | 0 | 210000 | 2000 | rpm | Float | IM | T |
| | <p>Description: Triggers speed threshold for PI/P switching. If the PI/P switching function is enabled and this condition is selected:</p> <ul style="list-style-type: none"> Switch from the PI control to the P control when the actual speed is larger than the threshold. Switch from the P control to the PI control when the actual speed is smaller than the threshold. | | | | | | | |
| p29143 | PI to P Switching Condition: Acceleration | 0 | 30000 | 20 | rev/s ² | Float | IM | T |
| | <p>Description: Triggers acceleration threshold for PI/P switching. If the PI/P switching function is enabled and this condition is selected:</p> <ul style="list-style-type: none"> Switch from the PI control to the P control when the actual acceleration is larger than the threshold. Switch from the P control to the PI control when the actual acceleration is smaller than the threshold. | | | | | | | |
| p29144 | PI to P Switching Condition: Pulse Deviation | 0 | 2147483647 | 30000 | LU | U32 | IM | T |
| | <p>Description: Triggers pulse deviation threshold for PI/P switching. If the PI/P switching function is enabled and this condition is selected:</p> <ul style="list-style-type: none"> Switch from the PI control to the P control when the actual pulse deviation is larger than the threshold. Switch from the P control to the PI control when the actual pulse deviation is smaller than the threshold. | | | | | | | |
| p29240 | Select Referencing Mode | 0 | 4 | 1 | - | I16 | RE | T |
| | <p>Description: Selects referencing mode.</p> <ul style="list-style-type: none"> 0: Referencing with external signal REF 1: Referencing with external reference cam (signal REF) 2: Referencing with zero mark only 3: Referencing with external reference cam (CCWL) and zero mark 4: Referencing with external reference cam (CWL) and zero mark | | | | | | | |

10.2 Parameter list

| Par. No. | Name | Min | Max | Factory Setting | Unit | Data type | Effective | Can be changed |
|----------|--|-----|----------------|-----------------|------|-----------|-----------|----------------|
| p29241 | Motion Mode | 0 | 3 | 0 | - | U16 | RE | T |
| | Description: Moves mode set for IPos: <ul style="list-style-type: none"> • 0: means relative moving • 1: means abs moving • 2: POS Mod • 3: NEG Mod | | | | | | | |
| p29242 | CLR Pulse Mode | 0 | 1 | 0 | - | U16 | IM | T |
| | Description: Indicates the mode for clear pulse. There are 4 bits for the setting, 3 is used and 1 is reserved. See below: bit 0: <ul style="list-style-type: none"> • 0: means automatically clear pulse when servo ON • 1: means clear pulse by the DI:CLR | | | | | | | |
| p29245 | Axis mode state | 0 | 1 | 0 | - | U32 | IM | T |
| | Description: Linear/modulo mode <ul style="list-style-type: none"> • 0: Linear axis • 1: Modulo axis | | | | | | | |
| p29246 * | Axis mode no | 1 | 429496729 5 | 360000 | - | U32 | IM | T |
| | Description: Modulo number, effective on modulo mode (P29245=1). | | | | | | | |
| p29247 * | Mechanical gear: pulse per revolution | 1 | 214748364 7 | 10000 | - | U32 | IM | T |
| | Description: LU per load revolution | | | | | | | |
| p29248 * | Mechanical gear: numerator | 1 | 1048576 | 1 | - | U32 | IM | T |
| | Description: (Load/Motor) Load revolutions | | | | | | | |
| p29249 * | Mechanical gear: denominator | 1 | 1048576 | 1 | - | U32 | IM | T |
| | Description: (Load/Motor) Motor revolutions | | | | | | | |
| p29250 | PTI Absolute Position Mode Enable | 0 | 1 | 0 | - | U32 | RE | T |
| | Description: Absolute Position Mode Enable. <ul style="list-style-type: none"> • =1 Enable Absolute Mode • =0 Disable Absolute Mode | | | | | | | |
| p29300 | Digital Input Forced Signals | 0 | 63 | 0 | - | U32 | IM | T, U |
| | Description: Input signals are forced to be high. 6 bits in total. <ul style="list-style-type: none"> • bit 0: SON • bit 1: CWL • bit 2: CCWL • bit 3: TLIM1 • bit 4: SPD1 • bit 5: TSET If one or more bits are set to be high, the corresponding input signals are forced to be logical high signals. | | | | | | | |

| Par. No. | Name | Min | Max | Factory Setting | Unit | Data type | Effective | Can be changed |
|--------------|---|-----|-----|-----------------|------|-----------|-----------|----------------|
| | Note: The drive unit displays the value in hex format. To know the logic (high/low) assignment to each bit, you must convert the hex number to the binary number, for example, FF (hex) = 11111111 (bin). | | | | | | | |
| p29301[0..3] | Digital Input 1 Assignment | 0 | 28 | 1 | - | l16 | IM | T |
| | <p>Description: Defines the function of digital input signal DI1 (PTI mode)</p> <ul style="list-style-type: none"> • SON 1 • RESET 2 • CWL 3 • CCWL 4 • G-CHANGE 5 • P-TRG 6 • CLR 7 • EGEAR1 8 • EGEAR2 9 • TLIMIT1 10 • TLIMIT2 11 • CWLE 12 • CCWLE 13 • ZSCLAMP 14 • SPD1 15 • SPD2 16 • SPD3 17 • TSET 18 • SLIMIT1 19 • SLIMIT2 20 • POS1 21 • POS2 22 • POS3 23 • REF 24 • SREF 25 • STEPF 26 • STEPB 27 • STEPH 28 <p>Index:</p> <ul style="list-style-type: none"> • [0]: DI1 for Control mode 0 • [1]: DI1 for Control mode 1 • [2]: DI1 for Control mode 2 • [3]: DI1 for Control mode 3 | | | | | | | |

10.2 Parameter list

| Par. No. | Name | Min | Max | Factory Setting | Unit | Data type | Effective | Can be changed |
|--------------|--|-----|-----|------------------------------|------|-----------|-----------|----------------|
| p29302[0..3] | Digital Input 2 Assignment | 0 | 28 | 2 | - | I16 | IM | T |
| | Description: Defines the function of digital input signal DI2 | | | | | | | |
| | Index: <ul style="list-style-type: none"> • [0]: DI2 for Control mode 0 • [1]: DI2 for Control mode 1 • [2]: DI2 for Control mode 2 • [3]: DI2 for Control mode 3 | | | | | | | |
| p29303[0..3] | Digital Input 3 Assignment | 0 | 28 | 3 | - | I16 | IM | T |
| | Description: Defines the function of digital input signal DI3 | | | | | | | |
| | Index: <ul style="list-style-type: none"> • [0]: DI3 for Control mode 0 • [1]: DI3 for Control mode 1 • [2]: DI3 for Control mode 2 • [3]: DI3 for Control mode 3 | | | | | | | |
| p29304[0..3] | Digital Input 4 Assignment | 0 | 28 | 4 | - | I16 | IM | T |
| | Description: Defines the function of digital input signal DI4 | | | | | | | |
| | Index: <ul style="list-style-type: none"> • [0]: DI4 for Control mode 0 • [1]: DI4 for Control mode 1 • [2]: DI4 for Control mode 2 • [3]: DI4 for Control mode 3 | | | | | | | |
| p29305[0..3] | Digital Input 5 Assignment | 0 | 28 | [0] 5; [1] 5; [2] 12; [3] 12 | - | I16 | IM | T |
| | Description: Defines the function of digital input signal DI5 | | | | | | | |
| | Index: <ul style="list-style-type: none"> • [0]: DI5 for Control mode 0 • [1]: DI5 for Control mode 1 • [2]: DI5 for Control mode 2 • [3]: DI5 for Control mode 3 | | | | | | | |
| p29306[0..3] | Digital Input 6 Assignment | 0 | 28 | [0] 6; [1] 6; [2] 13; [3] 13 | - | I16 | IM | T |
| | Description: Defines the function of digital input signal DI6 | | | | | | | |

| Par. No. | Name | Min | Max | Factory Setting | Unit | Data type | Effective | Can be changed |
|--------------|---|-----|-----|--------------------------------|------|-----------|-----------|----------------|
| | Index: <ul style="list-style-type: none"> • [0]: DI6 for Control mode 0 • [1]: DI6 for Control mode 1 • [2]: DI6 for Control mode 2 • [3]: DI6 for Control mode 3 | | | | | | | |
| p29307[0..3] | Digital Input 7 Assignment | 0 | 28 | [0] 7; [1] 21; [2] 15; [3] 18 | - | I16 | IM | T |
| | Description: Defines the function of digital input signal DI7 | | | | | | | |
| | Index: <ul style="list-style-type: none"> • [0]: DI7 for Control mode 0 • [1]: DI7 for Control mode 1 • [2]: DI7 for Control mode 2 • [3]: DI7 for Control mode 3 | | | | | | | |
| p29308[0..3] | Digital Input 8 Assignment | 0 | 28 | [0] 10; [1] 22; [2] 16; [3] 19 | - | I16 | IM | T |
| | Description: Defines the function of digital input signal DI8 | | | | | | | |
| | Index: <ul style="list-style-type: none"> • [0]: DI8 for Control mode 0 • [1]: DI8 for Control mode 1 • [2]: DI8 for Control mode 2 • [3]: DI8 for Control mode 3 | | | | | | | |
| p29330 | Digital Output 1 Assignment | 1 | 13 | 1 | - | U16 | IM | T |
| | Description: Defines the function of digital output signal DO1 <ul style="list-style-type: none"> • 1: RDY • 2: ALM • 3: INP • 4: ZSP • 5: SPDR • 6: TLR • 7: SPLR • 8: MBR • 9: OLL • 10: WRN1 • 11: WRN2 • 12: REFOK • 13: CM_STA | | | | | | | |

| Par. No. | Name | Min | Max | Factory Setting | Unit | Data type | Effective | Can be changed |
|----------|---|-----|-----|-----------------|------|-----------|-----------|----------------|
| p29331 | Digital Output 2 Assignment | 1 | 13 | 2 | - | U16 | IM | T |
| | Description: Defines the function of digital output signal DO2 | | | | | | | |
| p29332 | Digital Output 3 Assignment | 1 | 13 | 3 | - | U16 | IM | T |
| | Description: Defines the function of digital output signal DO3 | | | | | | | |
| p29333 | Digital Output 4 Assignment | 1 | 13 | 5 | - | U16 | IM | T |
| | Description: Defines the function of digital output signal DO4 | | | | | | | |
| p29334 | Digital Output 5 Assignment | 1 | 13 | 6 | - | U16 | IM | T |
| | Description: Defines the function of digital output signal DO5 | | | | | | | |
| p29335 | Digital Output 6 Assignment | 1 | 13 | 8 | - | U16 | IM | T |
| | Description: Defines the function of digital output signal DO6 | | | | | | | |
| p29340 | Warning 1 Assigned for Digital Output | 1 | 6 | 1 | - | U16 | IM | T |
| | Description: Defines conditions for WRN1. <ul style="list-style-type: none"> • 1: Motor overload protection warning: 85% of overload threshold has been reached. • 2: Holding brake power overload warning: 85% of overload threshold has been reached. • 3: Fan warning: fan has stopped for more than 1 s. • 4: Encoder warning • 5: Motor overtemperature warning: 85% of overtemperature threshold has been reached. • 6: Capacitor service life warning: The capacitor has reached its expiry, so replace it. | | | | | | | |
| p29341 | Warning 2 Assigned for Digital Output | 1 | 6 | 2 | - | U16 | IM | T |
| | Description: Defines conditions for WRN2. <ul style="list-style-type: none"> • 1: Motor overload protection warning: 85% of overload threshold has been reached. • 2: Holding brake power overload warning: 85% of overload threshold has been reached. • 3: Fan warning: life time of fan expired (40000 hours), replacement of fan needed. • 4: Encoder warning • 5: Motor overtemperature warning: 85% of overtemperature threshold has been reached. • 6: Capacitor service life warning: The capacitor has reached its expiry, so replace it. | | | | | | | |

| Par. No. | Name | Min | Max | Factory Setting | Unit | Data type | Effective | Can be changed |
|---|------------------------------------|-----|-----|-----------------|------|-----------|-----------|----------------|
| p29350 | Select sources for analog output 1 | 0 | 12 | 0 | - | U16 | IM | T |
| <p>Description: Selects signal source for analog output 1.</p> <ul style="list-style-type: none"> • 0: Actual speed (reference p29060) • 1: Actual torque (reference 3 × r0333) • 2: Speed setpoint (reference p29060) • 3: Torque setpoint (reference 3 × r0333) • 4: DC bus voltage (reference 1000 V) • 5: Pulse input frequency (reference 1k) • 6: Pulse input frequency (reference 10k) • 7: Pulse input frequency (reference 100k) • 8: Pulse input frequency (reference 1000k) • 9: Remaining number of pulses (reference 1k) • 10: Remaining number of pulses (reference 10k) • 11: Remaining number of pulses (reference 100k) • 12: Remaining number of pulses (reference 1000k) | | | | | | | | |
| p29351 | Select Signal Source for Analog 2 | 0 | 12 | 1 | - | U16 | IM | T |
| <p>Description: Selects signals for analog output 2.</p> <ul style="list-style-type: none"> • 0: Actual speed (reference p29060) • 1: Actual torque (reference 3 × r0333) • 2: Speed setpoint (reference p29060) • 3: Torque setpoint (reference 3 × r0333) • 4: DC bus voltage (reference 1000 V) • 5: Pulse input frequency (reference 1k) • 6: Pulse input frequency (reference 10k) • 7: Pulse input frequency (reference 100k) • 8: Pulse input frequency (reference 1000k) • 9: Remaining number of pulses (reference 1k) • 10: Remaining number of pulses (reference 10k) • 11: Remaining number of pulses (reference 100k) • 12: Remaining number of pulses (reference 1000k) | | | | | | | | |

* Note that the parameter value may be changed after commissioning. Make sure you back up the parameters first as required if you desire to replace the motor.

** Note that the parameter default values are motor dependent. They may have different default values when different motor connected.

Read-only parameters

| Par. No. | Name | Unit | Data type |
|----------|--|------|-----------|
| r0020 | Speed setpoint smoothed | rpm | Float |
| | Description: Displays the currently smoothed speed setpoint at the input of the speed controller or U/f characteristic (after the interpolator). | | |
| | Note: Smoothing time constant = 100 ms The signal is not suitable as a process quantity and may only be used as a display quantity. The speed setpoint is available smoothed (r0020) and unsmoothed. | | |
| r0021 | Actual speed smoothed | rpm | Float |
| | Description: Displays the smoothed actual value of the motor speed. | | |
| | Note: Smoothing time constant = 100 ms The signal is not suitable as a process quantity and may only be used as a display quantity. The speed actual value is available smoothed (r0021) and unsmoothed. | | |
| r0026 | DC link voltage smoothed | V | Float |
| | Description: Displays the smoothed actual value of the DC link voltage. | | |
| | Notice: When measuring a DC link voltage < 200 V, for the Power Module (e.g. PM340) a valid measured value is not supplied. In this case, when an external 24 V power supply is connected, a value of approx. 24 V is displayed in the display parameter. Note: Smoothing time constant = 100 ms The signal is not suitable as a process quantity and may only be used as a display quantity. The DC link voltage is available smoothed (r0026) and unsmoothed. | | |
| r0027 | Absolute actual current smoothed | Arms | Float |
| | Description: Displays the smoothed absolute actual current value. | | |
| | Notice: This smoothed signal is not suitable for diagnostics or evaluation of dynamic operations. In this case, the unsmoothed value should be used. Note: Smoothing time constant = 100 ms The signal is not suitable as a process quantity and may only be used as a display quantity. The absolute current actual value is available smoothed (r0027) and unsmoothed. | | |
| r0029 | Current actual value field-generating smoothed | Arms | Float |
| | Description: Displays the smoothed field-generating actual current. | | |
| | Note: Smoothing time constant = 100 ms The signal is not suitable as a process quantity and may only be used as a display quantity. The field-generating current actual value is available smoothed (r0029) and unsmoothed. | | |
| r0030 | Current actual value torque-generating smoothed | Arms | Float |
| | Description: Displays the smoothed torque-generating actual current. | | |
| | Note: Smoothing time constant = 100 ms The signal is not suitable as a process quantity and may only be used as a display quantity. The torque-generating current actual value is available smoothed. | | |
| r0031 | Actual torque smoothed | Nm | Float |
| | Description: Displays the smoothed torque actual value. | | |
| | Note: Smoothing time constant = 100 ms The signal is not suitable as a process quantity and may only be used as a display quantity. The torque actual value is available smoothed (r0031) and unsmoothed. | | |

| Par. No. | Name | Unit | Data type |
|--|--|------|-----------|
| r0033 | Torque utilization smoothed | % | Float |
| | <p>Description: Displays the smoothed torque utilization as a percentage. The torque utilization is obtained from the required smoothed torque in reference to the torque limit, scaled using p2196.</p> | | |
| | <p>Note: Smoothing time constant = 100 ms The signal is not suitable as a process quantity and may only be used as a display quantity. The torque utilization is available smoothed (r0033) and unsmoothed. For M_set total (r0079) > M_max offset, the following applies:</p> <ul style="list-style-type: none"> • demanded torque = M_set total - M_max offset • actual torque limit = M_max upper effective - M_max offset <p>For M_set total (r0079) <= M_max offset (p1532), the following applies:</p> <ul style="list-style-type: none"> • demanded torque = M_max offset - M_set total • actual torque limit = M_max offset - M_max lower effective <p>For the actual torque limit = 0, the following applies: r0033 = 100 % For the actual torque limit < 0, the following applies: r0033 = 0 %</p> | | |
| | | | |
| r0037[0...19] | Power unit temperatures | °C | Float |
| | <p>Description: Displays the temperatures in the power unit.</p> | | |
| | <p>Index:</p> <ul style="list-style-type: none"> • [0]: Inverter maximum value • [1]: Depletion layer maximum value • [2]: Rectifier maximum value • [3]: Air intake • [4]: Interior of power unit • [5]: Inverter 1 • [6]: Inverter 2 • [7]: Inverter 3 • [8]: Inverter 4 • [9]: Inverter 5 • [10]: Inverter 6 • [11]: Rectifier 1 • [12]: Rectifier 2 • [13]: Depletion layer 1 • [14]: Depletion layer 2 • [15]: Depletion layer 3 • [16]: Depletion layer 4 • [17]: Depletion layer 5 • [18]: Depletion layer 6 • [19]: Cooling unit liquid intake | | |
| | <p>Dependency: Refer to A01009</p> | | |
| <p>Notice: Only for internal Siemens troubleshooting.</p> | | | |

| Par. No. | Name | Unit | Data type |
|--------------|--|------|-----------|
| | <p>Note: The value of -200 indicates that there is no measuring signal.</p> <ul style="list-style-type: none"> r0037[0]: Maximum value of the inverter temperatures (r0037[5...10]). r0037[1]: Maximum value of the depletion layer temperatures (r0037[13...18]). r0037[2]: Maximum value of the rectifier temperatures (r0037[11...12]). <p>The maximum value is the temperature of the hottest inverter, depletion layer, or rectifier.</p> | | |
| r0079[0...1] | Torque setpoint total | Nm | Float |
| | <p>Description: Displays and connector output for the torque setpoint at the output of the speed controller (before clock cycle interpolation).</p> <p>Index:</p> <ul style="list-style-type: none"> [0]: Unsmoothed [1]: Smoothed | | |
| r0296 | DC link voltage undervoltage threshold | V | U16 |
| | <p>Description: Threshold to detect a DC link undervoltage. If the DC link voltage falls below this threshold, the drive unit is tripped due to a DC link undervoltage condition.</p> <p>Note: The value depends on the device type and the selected device rated voltage (p0210).</p> | | |
| r0297 | DC link voltage overvoltage threshold | V | U16 |
| | <p>Description: If the DC link voltage exceeds the threshold specified here, the drive unit is tripped due to DC link overvoltage.</p> <p>Dependency: Refer to F30002.</p> | | |
| r0311 | Rated motor speed | rpm | Float |
| | <p>Description: Displays the rated motor speed (rating plate).</p> | | |
| r0333 | Rated motor torque | Nm | Float |
| | <p>Description: Displays the rated motor torque. IEC drive: unit Nm NEMA drive: unit lbf ft</p> | | |
| r0482[0...2] | Encoder actual position value Gn_XIST1 | - | U32 |
| | <p>Description: Displays the encoder actual position value Gn_XIST1.</p> <p>Index:</p> <ul style="list-style-type: none"> [0]: Encoder 1 [1]: Encoder 2 [2]: Reserved | | |

| Par. No. | Name | Unit | Data type |
|--------------|--|------|-----------|
| | Note: <ul style="list-style-type: none"> In this value, the measuring gear is only taken into account when the position tracking is activated. The update time for the position control (EPOS) corresponds to the position controller clock cycle. The update time in isochronous operation corresponds to the bus cycle time. The update time in isochronous operation and with position control (EPOS) corresponds to the position controller clock cycle. The update time in non-isochronous operation or without position control (EPOS) comprises the following: <ul style="list-style-type: none"> Update time = 4 * least common multiple (LCM) of all current controller clock cycles in the drive group (infeed + drives). The minimum update time is 1 ms. Example 1: infeed, servo Update time = 4 * LCM(250 µs, 125 µs) = 4 * 250 µs = 1 ms Example 2: infeed, servo, vector Update time = 4 * LCM(250 µs, 125 µs, 500 µs) = 4 * 500 µs = 2 ms | | |
| r0632 | Motor temperature model, stator winding temperature | °C | Float |
| | Description: Displays the stator winding temperature of the motor temperature model. | | |
| r0722 | CU digital inputs status | - | U32 |
| | Description: Displays the status of the digital inputs. | | |
| | Note: DI: Digital Input DI/DO: Bidirectional Digital Input/Output The drive unit displays the value in hex format. You can convert the hex number to the binary number, for example, FF (hex) = 11111111 (bin). | | |
| r0747 | CU digital outputs status | - | U32 |
| | Description: Displays the status of digital outputs. | | |
| | Note: DI/DO: Bidirectional Digital Input/Output The drive unit displays the value in hex format. You can convert the hex number to the binary number, for example, FF (hex) = 11111111 (bin). | | |
| r2521[0...3] | LR position actual value | LU | I32 |
| | Description: Displays the actual position actual value determined by the position actual value preprocessing. | | |
| | Index: <ul style="list-style-type: none"> [0]: CI-loop pos ctrl [1]: Encoder 1 [2]: Encoder 2 [3]: Reserved | | |
| r2563 | LR following error dynamic model | LU | I32 |
| | Description: Displays the dynamic following error. | | |
| | This value is the deviation, corrected by the velocity-dependent component, between the position setpoint and the position actual value. | | |
| r2665 | EPOS position setpoint | LU | I32 |
| | Description: Displays the actual absolute position setpoint. | | |

Parameters

10.2 Parameter list



| Par. No. | Name | Unit | Data type |
|----------|---|------|-----------|
| r29015 | PTI: Pulse input frequency | Hz | Float |
| | Description: Displays the PTI input pulse frequency. | | |
| r29018 | OA version | - | Float |
| | Description: Firmware version | | |
| r29400 | Internal Control Signal Status Indicating | - | U32 |
| | Description: Control signal status identifiers bit00 SON bit01 RESET bit02 CWL bit03 CCWL bit04 G-CHANGE bit05 P-TRG bit06 CLR bit07 EGEAR1 bit08 EGEAR2 bit09 TLIMIT1 bit10 TLIMIT2 bit11 CWLE bit12 CCWLE bit13 ZSCLAMP bit14 SPD1 bit15 SPD2 bit16 SPD3 bit17 TSET bit18 SLIMIT1 bit19 SLIMIT2 bit20 POS1 bit21 POS2 bit22 POS3 bit23 REF bit24 SREF bit25 STEPF bit26 STEPB bit27 STEPH bit28 EMGS bit29 C-MODE | | |
| r29942 | DO signals status indicating | - | U32 |
| | Description: Indicates the status of DO signals. <ul style="list-style-type: none"> • bit 0: RD • bit 1: FAULT • bit 2: INP • bit 3: ZSP • bit 4: SPDR • bit 5: TLR • bit 6: SPLR • bit 7: MBR • bit 8: OLL • bit 9: WARNING1 • bit 10: WARNING2 • bit 11: REFOK • bit 12: MODE_SELECTED | | |
| r29979 | PStatus | - | U32 |
| | Description: Displays the status of position loop. <ul style="list-style-type: none"> • bit 0 - bit 1: actual EGear index | | |

Diagnostics

11.1 Overview

Differences between faults and alarms

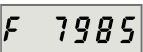
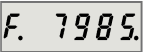
The differences between faults and alarms are shown as follows:

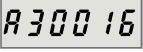
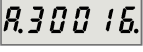
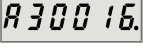
| Type | BOP display (example) | | Status indicator | | Reaction | Acknowledgement |
|-------|---|--|----------------------|-----|--|--|
| | | | RDY | COM | | |
| Fault |  | Single fault | Slow flashing in red | - | <ul style="list-style-type: none"> • NONE: no reaction • OFF1: servo motor ramps down • OFF2: servo motor coasts down • OFF3: servo motor stops quickly (emergency stop) • ENOCDER: Encoder fault causes OFF2. | <ul style="list-style-type: none"> • POWER ON: re-power on the servo drive to clear a fault after eliminating its cause. • IMMEDIATELY: the fault disappears immediately after eliminating its cause. • PULSE INHIBIT: The fault can only be acknowledged with a pulse inhibit. The same options are available for acknowledging as described under acknowledgment with IMMEDIATELY. |
| |  | The first fault in the case of multiple faults | | | | |
| |  | Non-first fault in the case of multiple faults | | | | |
| Alarm |  | Single alarm | Slow flashing in red | - | <ul style="list-style-type: none"> • NONE: no reaction | Self-acknowledgement |
| |  | The first alarm in the case of multiple alarms | | | | |
| |  | Non-first alarm in the case of multiple alarms | | | | |

NOTICE

Faults have higher display priority than alarms

In the case that both faults and alarms occur, only faults are displayed until they have been acknowledged.

BOP operations for faults and alarms

To view faults or alarms, proceed as follows:

- Faults

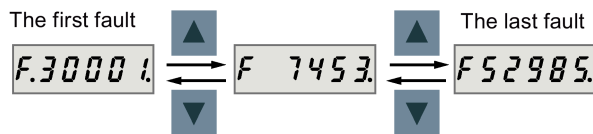

Figure 11-1 Viewing faults

- Alarms

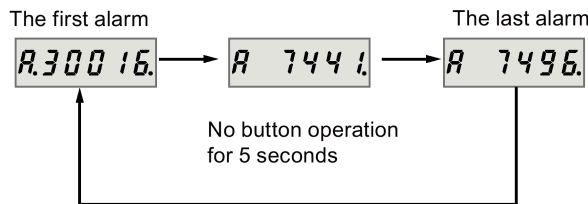

Figure 11-2 Viewing alarms

To exit from fault or alarm display, proceed as follows:

- Faults

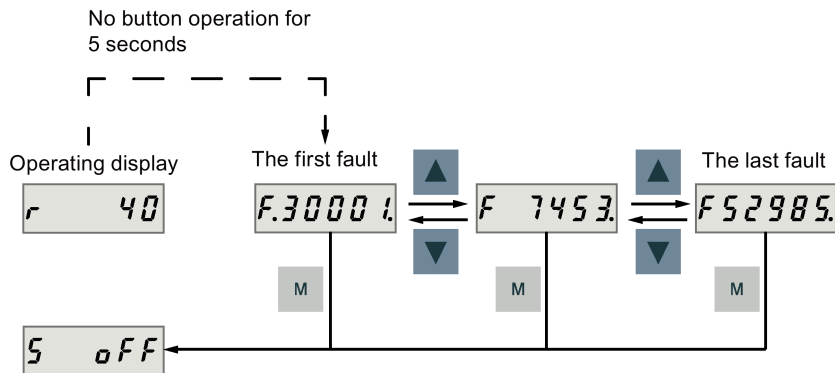

Figure 11-3 Exiting from fault display

- Alarms

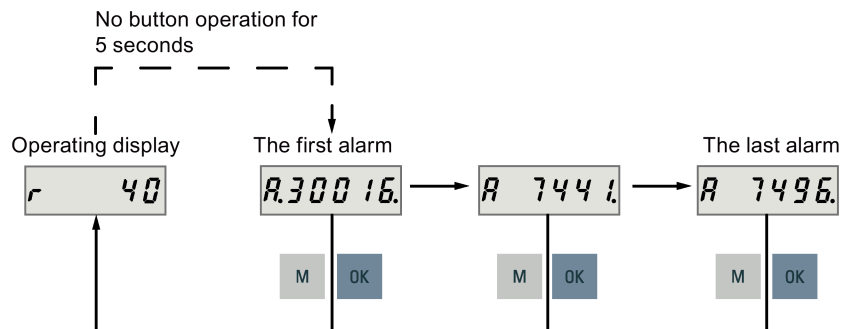

Figure 11-4 Exiting from alarm display

To acknowledge faults, proceed as follows:

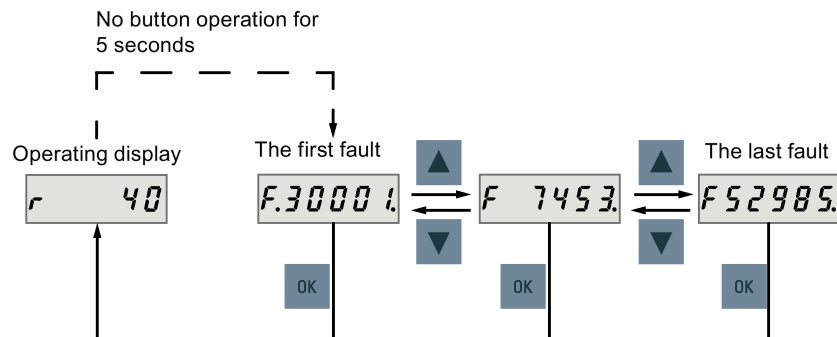
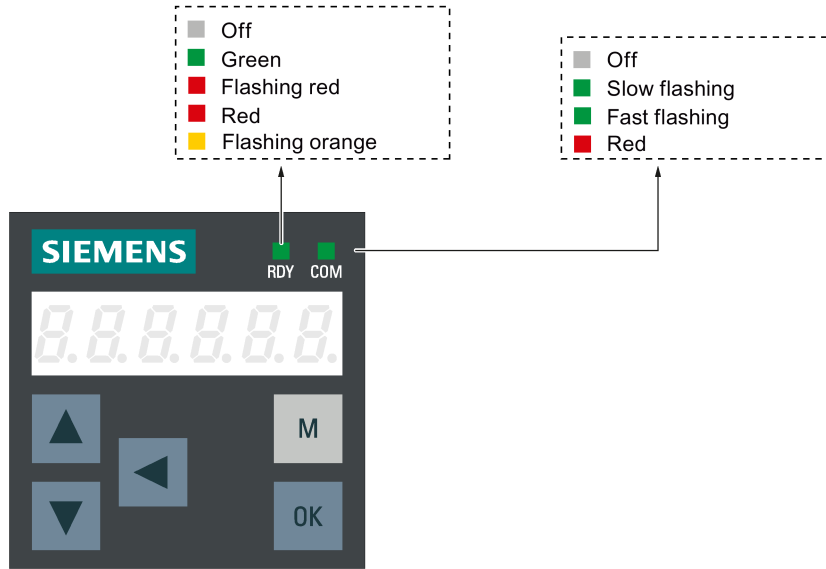

Figure 11-5 Acknowledging faults

Note

- If you do not eliminate the cause(s) of the fault, it can appear again after no button operation for five seconds. Make sure that you have eliminated the cause(s) of the fault.
- You can acknowledge faults using RESET signal. For details of the signal, refer to DIs (Page 61).
- You can acknowledge faults on the SINAMICS V-ASSISTANT. For details, refer to SINAMICS V-ASSISTANT Online Help.

Two LED status indicators (RDY and COM) are available to indicate drive status. Both LEDs are dual color (green/red).



You can find detailed information about the status indications in the table below:

| Status indicator | Color | Status | Description |
|------------------|----------------|---|---|
| RDY | - | Off | 24 V control board power supply is missing |
| | Green | Continuously lit | The drive is in the servo on state |
| | Red | Continuously lit | The drive is in the servo off state or in the startup state |
| | | Flash at 1 Hz | Alarms or faults occurs |
| | Red and orange | Flash alternatively at an interval of 0.5 s | The servo drive is located |
| COM | - | Off | Communication with PC is not active |
| | Green | Flash at 0.5 Hz | Communication with PC is active |
| | | Flash at 2 Hz | SD card operating (read or write) |
| | Red | Continuously lit | Communication with PC is in error |

11.2 List of faults and alarms

Fault list

| Fault | Cause | Remedy |
|---|---|--|
| F1000: Internal software error Reaction: OFF2 Acknowledgement: POWER ON | An internal software error has occurred. | <ul style="list-style-type: none"> Evaluate fault buffer. Carry out a POWER ON (power off/on) for all components. Upgrade firmware to later version. Contact the Hotline. Replace the Control Unit. |
| F1001: FloatingPoint exception Reaction: OFF2 Acknowledgement: POWER ON | An exception occurred during an operation with the FloatingPoint data type. | <ul style="list-style-type: none"> Carry out a POWER ON (power off/on) for all components. Upgrade firmware to the latest version. Contact the Hotline. |
| F1002: Internal software error Reaction: OFF2 Acknowledgement: IMMEDIATELY | An internal software error has occurred. | <ul style="list-style-type: none"> Carry out a POWER ON (power off/on) for all components. Upgrade firmware to the latest version. Contact the Hotline. |
| F1003: Acknowledgement delay when accessing the memory Reaction: OFF2 Acknowledgement: IMMEDIATELY | A memory area was accessed that does not return a "READY". | <ul style="list-style-type: none"> Carry out a POWER ON (power off/on). Contact the Hotline. |
| F1015: Internal software error Reaction: OFF2 Acknowledgement: POWER ON | An internal software error has occurred. | <ul style="list-style-type: none"> Carry out a POWER ON (power off/on) for all components. Upgrade firmware to the latest version. Contact the Hotline. |
| F1018: Booting has been interrupted several times Reaction: NONE Acknowledgement: POWER ON | Module booting was interrupted several times. As a consequence, the module boots with the factory setting. Possible reasons for booting being interrupted: <ul style="list-style-type: none"> Power supply interrupted. CPU crashed. Parameterization invalid. After this fault is output, then the module is booted with the factory settings. | <ul style="list-style-type: none"> Carry out a POWER ON (power off/on). After switching on, the module reboots from the valid parameterization (if available). Restore the valid parameterization Examples: <ul style="list-style-type: none"> Carry out a first commissioning, save, carry out a POWER ON (switch-off/switch-on). Load another valid parameter backup (e.g. from the memory card), save, carry out a POWER ON (switch-off/switch-on). Note: If the fault situation is repeated, then this fault is again output after several interrupted boots. |

11.2 List of faults and alarms

| Fault | Cause | Remedy |
|--|---|---|
| F1030: Sign-of-life failure for master control Reaction: OFF3 Acknowledgement: IMMEDIATELY | For active PC master control, no sign-of-life was received within the monitoring time. | Contact the Hotline. |
| F1611: SI CU: Defect detected Reaction: OFF2 Acknowledgement: IMMEDIATELY | The drive-integrated "Safety Integrated" (SI) function on the Control Unit (CU) has detected an error and initiated an STO | <ul style="list-style-type: none"> • Carry out a POWER ON (power off/on) for all components. • Upgrade software. • Replace the Control Unit. |
| F7011: Motor overtemperature Reaction: OFF2 Acknowledgement: IMMEDIATELY | <ul style="list-style-type: none"> • Motor overloaded • Motor surrounding temperature too high • Wire breakage or sensor not connected • Motor temperature model incorrectly parameterized | <ul style="list-style-type: none"> • Reduce the motor load. • Check the surrounding temperature and the motor ventilation. • Check the wiring and the connection. • Check the motor temperature model parameters. |
| F7085: Open-loop/closed-loop control parameters changed Reaction: NONE Acknowledgement: IMMEDIATELY | Open-loop/closed-loop control parameters have had to be changed for the following reasons: <ul style="list-style-type: none"> • As a result of other parameters, they have exceeded the dynamic limits. • They cannot be used due to the fact that the hardware detected not having certain features. | It is not necessary to change the parameters as they have already been correctly limited. |
| F7403: Lower DC link voltage threshold reached Reaction: OFF1 Acknowledgement: IMMEDIATELY | The DC link voltage monitoring is active and the lower DC link voltage threshold was reached in the "Operation" state. | <ul style="list-style-type: none"> • Check the line supply voltage. • Check the infeed. • Reduce the lower DC link threshold. • Switch out (disable) the DC link voltage monitoring. |
| F7404: Upper DC link voltage threshold reached Reaction: OFF2 Acknowledgement: IMMEDIATELY | The DC link voltage monitoring is active and the upper DC link voltage threshold was reached in the "Operation" state. | <ul style="list-style-type: none"> • Check the line supply voltage. • Check the infeed module or the brake module. • Increase the upper DC link voltage threshold. • Switch out (disable) the DC link voltage monitoring. |
| F7410: Current controller output limited Reaction: OFF2 Acknowledgement: IMMEDIATELY | The condition " $I_{act} = 0$ and $U_q_set_1$ longer than 16 ms at its limit" is present and can be caused by the following: <ul style="list-style-type: none"> • Motor not connected or motor contactor open. • No DC link voltage present. • Motor Module defective. | <ul style="list-style-type: none"> • Connect the motor or check the motor contactor. • Check the DC link voltage. • Check the Motor Module. |

| Fault | Cause | Remedy |
|--|--|--|
| F7412: Commutation angle incorrect (motor model) Reaction: ENCODER Acknowledgement: IMMEDIATELY | An incorrect commutation angle was detected that can result in a positive coupling in the speed controller. Possible causes: <ul style="list-style-type: none"> • The motor encoder is incorrectly adjusted with respect to the magnet position. • The motor encoder is damaged. • Data to calculate the motor model has been incorrectly set. • Pole position identification might have calculated an incorrect value when activated. • The motor encoder speed signal is faulted. • The control loop is instable due to incorrect parameterization. | <ul style="list-style-type: none"> • If the encoder mounting was changed, re-adjust the encoder. • Replace the defective motor encoder. • Correctly set the motor stator resistance, cable resistance and motor-stator leakage inductance. Calculate the cable resistance from the cross-section and length, check the inductance and stator resistance using the motor data sheet, measure the stator resistance, e.g. using a multimeter - and if required, again identify the values using the stationary motor data identification. • With pole position identification activated, check the procedure for pole position identification and force a new pole position identification procedure by means of de-selection followed by selection. |
| F7430: Changeover to open-loop torque controlled operation not possible Reaction: OFF2 Acknowledgement: POWER ON | For encoderless operation, the converter cannot change over to closed-loop torque-controlled operation. | <ul style="list-style-type: none"> • Do not attempt to change over to closed-loop torque-controlled operation. • Check the encoder cable connection. |
| F7431: Changeover to encoderless operation not possible Reaction: OFF2 Acknowledgement: POWER ON | For closed-loop torque control, the converter cannot change over to encoderless operation. | <ul style="list-style-type: none"> • Do not attempt to change over to encoderless operation. • Check the encoder cable connection. |
| F7442: LR: Multiturn does not match the modulo range Reaction: OFF1 (OFF2, OFF3) Acknowledgement: IMMEDIATELY | The ratio between the multiturn resolution and the modulo range (p29246) is not an integer number. This results in the adjustment being set back, as the position actual value cannot be reproduced after power-off/power-on. | Make the ration between the multiturn resolution and the modulo range an integer number. The ratio v is calculated as follows: $v = (4096 * p29247 * p29248) / (p29249 * p29246)$ |
| F7443: Reference point coordinate not in the permissible range Reaction: OFF1 (OFF2, OFF3) Acknowledgement: IMMEDIATELY | The reference point coordinate received when adjusting the encoder via connector input p2599 lies outside the half of the encoder range and cannot be set as actual axis position. | Set the reference point coordinate to a lower value than specified in the fault value. See also: p2599 (EPOS reference point coordinate value). For a motor with an absolute encoder, the maximum permissible encoder range is calculated by the formula $(4096 * p29247) / 2$. |

11.2 List of faults and alarms

| Fault | Cause | Remedy |
|---|--|--|
| <p>F7450: Standstill monitoring has responded Reaction: OFF1 Acknowledgement: IMMEDIATELY</p> | <p>After the standstill monitoring time expired, the drive left the standstill window.</p> <ul style="list-style-type: none"> • Position loop gain too low. • Position loop gain too high (instability/oscillation). • Mechanical overload. • Connecting cable, motor/drive converter incorrect (phase missing, interchange). | <p>Check the causes and resolve.</p> |
| <p>F7452: Following error too high Reaction: OFF1 Acknowledgement: IMMEDIATELY</p> | <p>The difference between the position setpoint and position actual value (following error dynamic model) is greater than the tolerance (p2546).</p> <ul style="list-style-type: none"> • The value of p2546 is too small. • The gain of position loop is too small. • The drive torque or accelerating capacity exceeded. • Position measuring system fault. • Position control sense incorrect. • Mechanical system locked. • Excessively high traversing velocity or excessively high position reference value (setpoint) differences. | <p>Check the causes and resolve.</p> |
| <p>F7453: Position actual value preprocessing error Reaction: OFF1 Acknowledgement: IMMEDIATELY</p> | <p>An error has occurred during the position actual value preprocessing.</p> | <p>Check the encoder for the position actual value preprocessing.</p> |
| <p>F7458: EPOS: Reference cam not found Reaction: OFF1 (OFF2, OFF3) Acknowledgement: IMMEDIATELY</p> | <p>After starting the search for reference, the axis moved through the maximum permissible distance to search for the reference cam without actually finding the reference cam.</p> | <ul style="list-style-type: none"> • Check the "reference cam" input. • Check the maximum permissible distance to the reference cam (p2606). <p>See also: p2606 (EPOS search for reference reference cam maximum distance)</p> |
| <p>F7459: Zero mark not detected Reaction: OFF1 Acknowledgement: IMMEDIATELY</p> | <p>After leaving the reference cam, the axis has traversed the maximum permissible distance (p2609) between the reference cam and the zero mark without finding the zero mark.</p> | <ul style="list-style-type: none"> • Check the encoder regarding zero mark. • Check the maximum permissible distance between the reference cam and zero mark (p2609). • Use an external encoder zero mark (equivalent zero mark). |

| Fault | Cause | Remedy |
|---|--|---|
| F7460: EPOS: End of reference cam not found Reaction: OFF1 (OFF2, OFF3) Acknowledgement: IMMEDIATELY | During the search for reference, when the axis reached the zero mark it also reached the end of the traversing range without detecting an edge at the binector input "reference cam". Maximum traversing range: -2147483648 [LU] ... -2147483647 [LU] | <ul style="list-style-type: none"> Check the "reference cam" input. Repeat the search for reference. |
| F7475: EPOS: Target position < start of traversing range Reaction: OFF1 (OFF2, OFF3) Acknowledgement: IMMEDIATELY | The target position for relative traversing lies outside the traversing range. | Correct the target position. |
| F7476: EPOS: Target position > end of the traversing range Reaction: OFF1 (OFF2, OFF3) Acknowledgement: IMMEDIATELY | The target position for relative traversing lies outside the traversing range. | Correct the target position. |
| F7481: EPOS: Axis position < software limit switch minus Reaction: OFF1 (OFF2, OFF3) Acknowledgement: IMMEDIATELY | The actual position of the axis is less than the position of the software limit switch minus. | <ul style="list-style-type: none"> Correct the target position. Change software limit switch minus (CI: p2580). |
| F7482: EPOS: Axis position > software limit switch plus Reaction: OFF1 (OFF2, OFF3) Acknowledgement: IMMEDIATELY | The actual position of the axis is greater than the position of the software limit switch plus. | <ul style="list-style-type: none"> Correct the target position. Change software limit switch plus (CI: p2581). |
| F7490: Enable signal withdrawn while traversing Reaction: OFF1 Acknowledgement: IMMEDIATELY | <ul style="list-style-type: none"> For a standard assignment, another fault may have occurred as a result of withdrawing the enable signals. The drive is in the "switching on inhibited" state (for a standard assignment). | <ul style="list-style-type: none"> Set the enable signals or check the cause of the fault that first occurred and then result (for a standard assignment). Check the assignment to enable the basic positioning function. |
| F7491: STOP cam minus reached Reaction: OFF3 Acknowledgement: IMMEDIATELY | The STOP cam minus was reached. For a positive traversing direction, the STOP cam minus was reached, i.e. the wiring of the STOP cam is incorrect. | <ul style="list-style-type: none"> Leave the STOP cam minus in the positive traversing direction and return the axis to the valid traversing range. Check the wiring of the STOP cam. |
| F7492: STOP cam plus reached Reaction: OFF3 Acknowledgement: IMMEDIATELY | The STOP cam plus was reached. For a negative traversing direction, the STOP cam plus was reached, i.e. the wiring of the STOP cam is incorrect. | <ul style="list-style-type: none"> Leave the STOP cam plus in the negative traversing direction and return the axis to the valid traversing range. Check the wiring of the STOP cam. |

| Fault | Cause | Remedy |
|---|--|--|
| <p>F7493: LR: Overflow of the value range for position actual value Reaction: OFF1 (OFF2, OFF3) Acknowledgement: IMMEDIATELY</p> | <p>The value range (-2147483648 ... 2147483647) for the position actual value representation was exceeded. When the overflow occurs, the "referenced" or "adjustment absolute measuring system" status is reset.</p> <ul style="list-style-type: none"> • The position actual value (r2521) has exceeded the value range. • The encoder position actual value has exceeded the value range. • The maximum encoder value times the factor to convert the absolute position from increments to length units (LU) has exceeded the value range for displaying the position actual value. | <p>If required, reduce the traversing range or position resolution p29247. Note for case = 3: If the value for the maximum possible absolute position (LU) is greater than 4294967296, then it is not possible to make an adjustment due to an overflow. For rotary encoders, the maximum possible absolute position (LU) is calculated as follows: Motor encoder without position tracking:</p> <ul style="list-style-type: none"> • IPOS: $p29247 * p29248 * 4096 / p29249$ for multiturn encoders • PTI: $1048576 * p29012[X] * 4096 / p29013$ for multiturn encoders |
| <p>F7599: Encoder 1: Adjustment not possible Reaction: OFF1 (NONE, OFF2, OFF3) Acknowledgement: IMMEDIATELY</p> | <p>The maximum encoder value times the factor to convert the absolute position from increments to length units (LU) has exceeded the value range (-2147483648 ... 2147483647) for displaying the position actual value.</p> | <p>If the value for the maximum possible absolute position (LU) is greater than 4294967296, then it is not possible to make an adjustment due to an overflow. For rotary encoders, the maximum possible absolute position (LU) is calculated as follows: Motor encoder without position tracking:</p> <ul style="list-style-type: none"> • IPOS: $p29247 * p29248 * 4096 / p29249$ for multiturn encoders • PTI: $1048576 * p29012[X] * 4096 / p29013$ for multiturn encoders |
| <p>F7800 Drive: No power unit present Reaction: NONE Acknowledgement: IMMEDIATELY</p> | <p>The power unit parameters cannot be read or no parameters are stored in the power unit.</p> | <ul style="list-style-type: none"> • Carry out a POWER ON (power off/on) for all components. • Change the module. |
| <p>F7801: Motor overcurrent Reaction: OFF2 Acknowledgement: IMMEDIATELY</p> | <p>The permissible motor limit current was exceeded.</p> <ul style="list-style-type: none"> • Effective current limit set too low. • Current controller not correctly set. • Motor was braked with an excessively high stall torque correction factor. • Up ramp was set too short or the load is too high. • Short-circuit in the motor cable or ground fault. • Motor current does not match the current of Motor Module. | <ul style="list-style-type: none"> • Reduce the stall torque correction factor. • Increase the up ramp or reduce the load. • Check the motor and motor cables for short-circuit and ground fault. • Check the Motor Module and motor combination. |

| Fault | Cause | Remedy |
|---|---|---|
| F7802: Infeed or power unit not ready Reaction: OFF2 Acknowledgement: IMMEDIATELY | After an internal power-on command, the infeed or drive does not signal ready because of one of the following reasons: <ul style="list-style-type: none"> • Monitoring time is too short. • DC link voltage is not present. • Associated infeed or drive of the signaling component is defective. | <ul style="list-style-type: none"> • Ensure that there is a DC link voltage. Check the DC link busbar. Enable the infeed. • Replace the associated infeed or drive of the signaling component. |
| F7815: Power unit has been changed Reaction: NONE Acknowledgement: IMMEDIATELY | The code number of the actual power unit does not match the saved number. | Connect the original power unit and power up the Control Unit again (POWER ON). |
| F7900: Motor blocked/speed controller at its limit Reaction: OFF2 Acknowledgement: IMMEDIATELY | The servo motor has been operating at the torque limit longer than 1s and below the speed threshold of 120 rpm . This signal can also be initiated if the speed actual value is oscillating and the speed controller output repeatedly goes to its limit. | <ul style="list-style-type: none"> • Check whether the servo motor can rotate freely or not. • Check the torque limit. • Check the inversion of the actual value. • Check the motor encoder connection. • Check the encoder pulse number. |
| F7901: Motor overspeed Reaction: OFF2 Acknowledgement: IMMEDIATELY | The maximumly permissible speed has been exceeded. | Check and correct the maximum speed (p1082). Check if there are any peaks of actual speed. If the value of the peak is especially large, contact the hotline. |
| F7995: Motor identification failure Reaction: OFF2 Acknowledgement: IMMEDIATELY | For incremental motor, needs pole position identification when first SON. If motor already in run (i.e. by external force) position identification may failure. | Stop motor before SON. |
| F30001: Power unit: Overcurrent Reaction: OFF2 Acknowledgement: IMMEDIATELY | The power unit has detected an overcurrent condition. <ul style="list-style-type: none"> • Closed-loop control is incorrectly parameterized. • Controller parameters are not proper. • Motor has a short-circuit or fault to ground (frame). • Power cables are not correctly connected. • Power cables exceed the maximum permissible length. • Power unit defective. • Line phase interrupted. | <ul style="list-style-type: none"> • Check the motor data - if required, carry out commissioning. • Modify speed loop Kp (p29120), position loop Kv (p29110). • Check the motor circuit configuration (star-delta). • Check the power cable connections. • Check the power cables for short-circuit or ground fault. • Check the length of the power cables. • Replace power unit. • Check the line supply phases. • Check the external braking resistor connection. |

11.2 List of faults and alarms

| Fault | Cause | Remedy |
|---|--|--|
| <p>F30002: DC link voltage, overvoltage Reaction: OFF2 Acknowledgement: IMMEDIATELY</p> | <p>The power unit has detected overvoltage in the DC link.</p> <ul style="list-style-type: none"> • Motor regenerates too much energy. • Device connection voltage too high. • Line phase interrupted. | <ul style="list-style-type: none"> • Increase the ramp-down time. • Activate the DC link voltage controller. • Use a braking resistor. • Increase the current limit of the infeed or use a larger module. • Check the device supply voltage. • Check the line supply phases. |
| <p>F30003: DC link voltage, undervoltage Reaction: OFF2 Acknowledgement: IMMEDIATELY</p> | <p>The power unit has detected an undervoltage condition in the DC link.</p> <ul style="list-style-type: none"> • Line supply failure • Line supply voltage below the permissible value. • Line supply infeed failed or interrupted. • Line phase interrupted. | <ul style="list-style-type: none"> • Check the line supply voltage • Check the line supply infeed and observe the fault messages relating to it (if there are any) • Check the line supply phases. • Check the line supply voltage setting. |
| <p>F30004: Drive heat sink over-temperature Reaction: OFF2 Acknowledgement: IMMEDIATELY</p> | <p>The temperature of the power unit heat sink has exceeded the permissible limit value.</p> <ul style="list-style-type: none"> • Insufficient cooling, fan failure. • Overload. • Surrounding temperature too high. • Pulse frequency too high. | <ul style="list-style-type: none"> • Check whether the fan is running. • Check the fan elements. • Check whether the surrounding temperature is in the permissible range. • Check the motor load. • Reduce the pulse frequency if this is higher than the rated pulse frequency. |
| <p>F30005: Power unit: Overload I^{2t} Reaction: OFF2 Acknowledgement: IMMEDIATELY</p> | <p>The power unit was overloaded.</p> <ul style="list-style-type: none"> • The permissible rated power unit current was exceeded for an inadmissibly long time. • The permissible load duty cycle was not maintained. | <ul style="list-style-type: none"> • Reduce the continuous load. • Adapt the load duty cycle. • Check the motor and power unit rated currents. |
| <p>F30011: Line phase failure in main circuit Reaction: OFF2 Acknowledgement: IMMEDIATELY</p> | <p>At the power unit, the DC link voltage ripple has exceeded the permissible limit value.</p> <p>Possible causes:</p> <ul style="list-style-type: none"> • A line phase has failed. • The 3 line phases are inadmissibly unsymmetrical. • The fuse of a phase of a main circuit has ruptured. • A motor phase has failed. | <ul style="list-style-type: none"> • Check the main circuit fuses. • Check whether a single-phase load is distorting the line voltages. • Check the motor feeder cables. |

| Fault | Cause | Remedy |
|--|--|---|
| F30015: Phase failure motor cable Reaction: OFF2 Acknowledgement: IMMEDIATELY | A phase failure in the motor feeder cable was detected. The signal can also be output in the following case: The motor is correctly connected, however the closed-speed control is instable and therefore an oscillating torque is generated. | <ul style="list-style-type: none"> • Check the motor feeder cables. • Check the speed controller settings. |
| F30021: Ground fault Reaction: OFF2 Acknowledgement: IMMEDIATELY | Power unit has detected a ground fault. <ul style="list-style-type: none"> • Ground fault in the power cables. • Winding fault or ground fault at the motor. | <ul style="list-style-type: none"> • Check the power cable connections. • Check the motor. |
| F30027: Precharging DC link time monitoring Reaction: OFF2 Acknowledgement: IMMEDIATELY | <ul style="list-style-type: none"> • The power unit DC link was not able to be pre-charged within the expected time. There is no line supply voltage connected. • The line contactor/line side switch has not been closed. • The line supply voltage is too low. • The pre-charging resistors are overheated as there were too many pre-charging operations per time unit • The pre-charging resistors are overheated as the DC link capacitance is too high. • The pre-charging resistors are overheated. • The pre-charging resistors are overheated as the line contactor was closed during the DC link fast discharge through the Braking Module. • The DC link has either a ground fault or a short-circuit. • The pre-charging circuit is possibly defective. | Check the line supply voltage at the input terminals. |
| F30036: Internal overtemperature Reaction: OFF2 Acknowledgement: IMMEDIATELY | The temperature inside the drive converter has exceeded the permissible temperature limit. <ul style="list-style-type: none"> • Insufficient cooling, fan failure. • Overload. • Surrounding temperature too high. | <ul style="list-style-type: none"> • Check whether the fan is running. • Check the fan elements. • Check whether the surrounding temperature is in the permissible range. Notice: This fault can only be acknowledged once the permissible temperature limit minus 5 K has been fallen below. |

11.2 List of faults and alarms

| Fault | Cause | Remedy |
|--|--|--|
| F30050: 24 V supply over-voltage Reaction: OFF2 Acknowledgement: POWER ON | The voltage monitor signals an overvoltage fault on the module. | <ul style="list-style-type: none"> • Check the 24 V power supply. • Replace the module if necessary. |
| F31100: Zero mark distance error Reaction: ENCODER Acknowledgement: PULSE INHIBIT | The measured zero mark distance does not correspond to the parameterized zero mark distance. For distance-coded encoders, the zero mark distance is determined from zero marks detected pairs. This means that if a zero mark is missing, depending on the pair generation, this cannot result in a fault and also has no effect in the system. | <ul style="list-style-type: none"> • Check that the encoder cables are routed in compliance with EMC. • Check the plug connections • Replace the encoder or encoder cable |
| F31101: Zero mark failed Reaction: ENCODER Acknowledgement: PULSE INHIBIT | The 1.5 x parameterized zero mark distance was exceeded. | <ul style="list-style-type: none"> • Check that the encoder cables are routed in compliance with EMC. • Check the plug connections. • Replace the encoder or encoder cable. |
| F31110: Serial communications error Reaction: ENCODER Acknowledgement: PULSE INHIBIT | Serial communication protocol transfer error between the encoder and evaluation module. | <ul style="list-style-type: none"> • Check the encoder cable and shielding connection. • Replace the encoder cable/encoder. |
| F31112: Error bit set in the serial protocol Reaction: ENCODER Acknowledgement: PULSE INHIBIT | The encoder sends a set error bit via the serial protocol. | <ul style="list-style-type: none"> • Check the encoder cable and shielding connection. • Replace the encoder cable/encoder. |
| F31117: Inversion error signals A/B/R Reaction: ENCODER Acknowledgement: PULSE INHIBIT | For a square-wave encoder (bipolar, double ended) signals A*, B* and R* are not inverted with respect to signals A, B and R. | <ul style="list-style-type: none"> • Check the encoder and cable and the connection of them. • Does the encoder supply signals and the associated inverted signals? |
| F31130: Zero mark and position error from the coarse synchronization Reaction: ENCODER Acknowledgement: PULSE INHIBIT | After initializing the pole position using track C/D, Hall signals or pole position identification routine, the zero mark was detected outside the permissible range. For distance-coded encoders, the test is carried out after passing 2 zero marks. Fine synchronization was not carried out. | <ul style="list-style-type: none"> • Check that the encoder cables are routed in compliance with EMC. • Check the plug connections • If the Hall sensor is used as an equivalent for track C/D, check the connection. • Check the connection of track C or D. • Replace the encoder or encoder cable. |
| F31150: Initialization error Reaction: ENCODER Acknowledgement: PULSE INHIBIT | Encoder functionality is not operating correctly. | <ul style="list-style-type: none"> • Check the encoder type used (incremental/absolute) and the encoder cable. • If relevant, note additional fault messages that describe the fault in detail. |

| Fault | Cause | Remedy |
|--|--|--|
| F52903: Fault inconsistency between fault status and fault buffer Reaction: OFF2 Acknowledgement: IMMEDIATELY | Fault status and fault number buffer are inconsistent. | Repower on. |
| F52904: Control mode change Reaction: OFF2 Acknowledgement: POWER ON | When the control mode is changed, the drive must be saved and restarted. | Save and restart the drive. |
| F52911: Positive torque limitation value error Reaction: OFF2 Acknowledgement: IMMEDIATELY | One of positive torque limitation values (P29050) becomes less than 0. | Configure all of positive torque limitation values (P29050) not less than 0. |
| F52912: Negative torque limitation value error Reaction: OFF2 Acknowledgement: IMMEDIATELY | One of negative torque limitation values (P29051) becomes greater than 0. | Configure all of negative torque limitation values (P29051) not greater than 0. |
| F52931: Gear box limit Reaction: OFF1 Acknowledgement: IMMEDIATELY | The electronic gear ratio (p29012[x] / p29013[x]) exceeds the range from 0.02 to 200. | Adjust the electronic gear ratio within the permissible range from 0.02 to 200. |
| F52933: PTO gear box limit Reaction: OFF1 Acknowledgement: IMMEDIATELY | The electronic gear ratio (p29031[0] / p29032[0]) exceeds the range from 0.02 to 200. | Adjust the electronic gear ratio within the permissible range from 0.02 to 200. |
| F52980: Absolute encoder motor changed Reaction: OFF1 Acknowledgement: IMMEDIATELY | The servo motor with absolute encoder is changed. Actual motor ID is different from commissioned motor ID. | The servo motor will be automatically configured after the acknowledgement of this fault. |
| F52981: Absolute encoder motor mismatched Reaction: OFF1 Acknowledgement: IMMEDIATELY | Connected absolute encoder motor cannot be operated. The servo drive in use does not support the Motor ID. | Use a suitable absolute encoder motor. |
| F52983: No encoder detected Reaction: OFF1 Acknowledgement: IMMEDIATELY | The servo drive in use does not support encoderless operation. | <ul style="list-style-type: none"> • Check the encoder cable connection between the servo drive and the servo motor. • Use a servo motor with encoder. |

11.2 List of faults and alarms

| Fault | Cause | Remedy |
|---|---|---|
| F52984: Incremental encoder motor not configured Reaction: OFF1 Acknowledgement: IMMEDIATELY | <ul style="list-style-type: none"> Commissioning of the servo motor has failed. The incremental encoder motor is connected but fails to commission. | Configure the motor ID by setting the parameter p29000. |
| F52985: Absolute encoder motor wrong Reaction: OFF1 Acknowledgement: IMMEDIATELY | <ul style="list-style-type: none"> Motor ID is downloaded wrong during manufacture. The software of the servo drive does not support the Motor ID. | <ul style="list-style-type: none"> Update the firmware. Use a correct absolute encoder motor. |
| F52987: Absolute encoder replaced Reaction: OFF1 Acknowledgement: IMMEDIATELY | Incorrect absolute encoder data. | Contact the Hotline. |

Alarm list

| Alarm | Cause | Remedy |
|---|--|---|
| A1009: Control module over-temperature | The temperature of the control module (Control Unit) has exceeded the specified limit value. | <ul style="list-style-type: none"> Check the air intake for the Control Unit. Check the Control Unit fan. Note: The alarm automatically disappears after the limit value has been undershot. |
| A1019: Writing to the removable data medium unsuccessful | The write access to the removable data medium was unsuccessful. | Remove and check the removable data medium. Then run the data backup again. |
| A1032: All parameters must be saved | The parameters of an individual drive object were saved, although there is still no backup of all drive system parameters. The saved object-specific parameters are not loaded the next time that the system powers up. For the system to successfully power up, all of the parameters must have been completely backed up. | Save all parameters. |
| A1045: Configuring data invalid | An error was detected when evaluating the parameter files saved in the non-volatile memory. Because of this, under certain circumstances, several of the saved parameter values were not able to be accepted. | Save the parameterization in SINAMICS V-ASSISTANT using the "Copy RAM to ROM" function or on the BOP. This overwrites the incorrect parameter files in the non-volatile memory – and the alarm is withdrawn. |
| A1920: Drive Bus: Receive setpoints after To | Output data of Drive Bus master (setpoints) received at the incorrect instant in time within the Drive Bus clock cycle. | <ul style="list-style-type: none"> Check bus configuration. Check parameters for clock cycle synchronization (ensure $T_o > T_{dx}$). Note: To: Time of setpoint acceptance Tdx: Data exchange time |

| Alarm | Cause | Remedy |
|--|---|---|
| A1932: Drive Bus clock cycle synchronization missing for DSC | There is no clock synchronization or clock synchronous sign of life and DSC is selected. Note: DSC: Dynamic Servo Control | Set clock synchronization across the bus configuration and transfer clock synchronous sign-of-life. |
| A5000: Drive heat sink overtemperature | Cause: The alarm threshold for overtemperature at the inverter heat sink has been reached. If the temperature of the heat sink increases by an additional 5 K, then fault F30004 is initiated. | Check the following: <ul style="list-style-type: none"> • Is the surrounding temperature within the defined limit values? • Have the load conditions and the load duty cycle been appropriately dimensioned? • Has the cooling failed? |
| A7012: Motor temperature model 1/3 overtemperature | The motor temperature model 1/3 identified that the alarm threshold was exceeded. | <ul style="list-style-type: none"> • Check the motor load and reduce it if required. • Check the motor surrounding temperature. |
| A7441: LR: Save the position offset of the absolute encoder adjustment | The status of the absolute encoder adjustment has changed. In order to permanently save the determined position offset (p2525) it must be saved. | Not necessary. This alarm automatically disappears after the offset has been saved. |
| A7456: EPOS: Setpoint velocity limited | The actual setpoint velocity is greater than the parameterized maximum velocity and is therefore limited. | Decrease the actual setpoint velocity. |
| A7461: EPOS: Reference point not set | When starting a traversing block/direct setpoint input, a reference point is not set. | Reference the system (search for reference, flying referencing, set reference point). |
| A7469: EPOS: Traversing block < target position < software limit switch minus | In the traversing block the specified absolute target position lies outside the range limited by the software limit switch minus. | <ul style="list-style-type: none"> • Correct the traversing block. • Change software limit switch minus (p2580). |
| A7470: EPOS: Traversing block > target position > software limit switch plus | In the traversing block the specified absolute target position lies outside the range limited by the software limit switch plus. | <ul style="list-style-type: none"> • Correct the traversing block. • Change software limit switch plus (p2581). |
| A7471: EPOS: Traversing block target position outside the modulo range | In the traversing block the target position lies outside the modulo range. | <ul style="list-style-type: none"> • In the traversing block, correct the target position. • Change the modulo range (p29246). |
| A7472: EPOS: Traversing block ABS_POS/ABS_NEG not possible | In the traversing block the positioning mode ABS_POS or ABS_NEG were parameterized with the modulo correction not activated. | Correct the traversing block. |
| A7473: EPOS: Beginning of traversing range reached | When traversing, the axis has moved to the traversing range limit. | Move away in the positive direction. |

| Alarm | Cause | Remedy |
|--|--|---|
| A7474: EPOS: End of traversing range reached | When traversing, the axis has moved to the traversing range limit. | Move away in the negative direction. |
| A7477: EPOS: Target position < software limit switch minus | In the actual traversing operation, the target position is less than the software limit switch minus. | <ul style="list-style-type: none"> • Correct the target position. • Change software limit switch minus (CI: p2580). |
| A7478: EPOS: Target position > software limit switch plus | In the actual traversing operation, the target position is greater than the software limit switch plus. | <ul style="list-style-type: none"> • Correct the target position. • Change software limit switch plus (CI: p2581). |
| A7479: EPOS: Software limit switch minus reached | The axis is at the position of the software limit switch minus. An active traversing block was interrupted. | <ul style="list-style-type: none"> • Correct the target position. • Change software limit switch minus (CI: p2580). |
| A7480: EPOS: Software limit switch plus reached | The axis is at the position of the software limit switch plus. An active traversing block was interrupted. | <ul style="list-style-type: none"> • Correct the target position. • Change software limit switch plus (CI: p2581). |
| A7496: SON enable missing | In the PTI mode or a compound mode with PTI, the drive is in the servo off state. | Enable servo on for the drive. |
| A7576: Encoder- less operation due to a fault active | Encoderless operation is active due to a fault. | <ul style="list-style-type: none"> • Remove the cause of a possible encoder fault. • Carry out a POWER ON (power off/on) for all components. |
| A7585: P-TRG or CLR active | In the PTI mode or a compound mode with PTI, the P-TRG or CLR function is activated. | In the PTI mode, deactivate the P-TRG or CLR function; in the compound mode with PTI, do not switch to other modes. |
| A7805: Power unit overload I²t | Alarm threshold for I ² t overload of the power unit exceeded. | <ul style="list-style-type: none"> • Reduce the continuous load. • Adapt the load duty cycle. • Check the assignment of the rated currents of the motor and motor module. |
| A7965: Save required | The angular commutation offset was re-defined and has still not been saved. In order to permanently accept the new value, it must be saved in a non-volatile fashion. | This alarm automatically disappears after the data has been saved. |
| A7971: Angular commutation offset determina- tion activated | The automatic determination of the angular commutation offset (encoder adjustment) is activated. The automatic determination is carried out at the next power-on command. | The alarm automatically disappears after determination. |
| A7991: Motor data identification activated | The motor data ident. routine is activated. The motor data identification routine is carried out at the next power-on command. | <p>The alarm automatically disappears after the motor data identification routine has been successfully completed.</p> <p>If a POWER ON or a warm restart is performed with motor data identification selected, the motor data identification request will be lost. If motor data identification is required, it will need to be selected again manually following ramp-up.</p> |

| Alarm | Cause | Remedy |
|---|---|--|
| A30016: Load supply switched off | The DC link voltage is too low. | <ul style="list-style-type: none"> • Switch on the load supply. • Check the line supply if necessary. |
| A30031: Hardware current limiting in phase U | <p>Hardware current limit for phase U responded. The pulsing in this phase is inhibited for one pulse period.</p> <ul style="list-style-type: none"> • Closed-loop control is incorrectly parameterized. • Fault in the motor or in the power cables. • The power cables exceed the maximum permissible length. • Motor load too high. • Power unit defective. <p>Note: Alarm A30031 is always output if, for a Power Module, the hardware current limiting of phase U, V or W responds.</p> | <p>Check the motor data. As an alternative, run a motor data identification.</p> <ul style="list-style-type: none"> • Check the motor circuit configuration (star-delta) • Check the motor load. • Check the power cable connections. • Check the power cables for short-circuit or ground fault. • Check the length of the power cables. |
| A31411: Absolute encoder signals internal alarms | The absolute encoder fault word includes alarm bits that have been set. | Replace the encoder. |
| A31412: Error bit set in the serial protocol | The encoder sends a set error bit via the serial protocol. | <ul style="list-style-type: none"> • Carry out a POWER ON (power off/on) for all components. • Check that the encoder cables are routed in compliance with EMC. • Check the plug connections. • Replace the encoder. |
| A52900: Failure during data copying | <ul style="list-style-type: none"> • Copying is halted. • The SD card was plugged out. • The drive is not in the stop state. | <ul style="list-style-type: none"> • Re-plug in the SD card. • Make sure the drive is in the stop state. |
| A52901: Braking resistor reaches alarm threshold | The heat capacity reaches the threshold (p29005) of the braking resistor capacity. | <ul style="list-style-type: none"> • Change the external braking resistor. • Increase deceleration time. |
| A52902: Emergency missing | Implement servo on when the emergency input (EMGS) is switched off. | Switch on the emergency input (EMGS) and then implement servo on. |
| A52932: PTO max limit | <p>For incremental encoder, when PTO frequency exceeds 280K, drive will output A52932 to remind that exceed limitation.</p> <p>For absolute encoder, when PTO frequency exceeds 120K, drive will output A52932 to remind that exceed limitation.</p> | Change PTO ratio. |

Appendix

A.1 Order numbers

Siemens provides various drive package alternatives. You can order the desired package according to your particular demands. When placing a purchase order, you only need to indicate the package order number.

SINAMICS V90 servo drives

| Maximum supported motor power (kW) | Order number |
|------------------------------------|--------------------|
| 0.4 | 6SL3210-5FE10-4UA0 |
| 0.75 | 6SL3210-5FE10-8UA0 |
| 1.0 | 6SL3210-5FE11-0UA0 |
| 1.75 | 6SL3210-5FE11-5UA0 |
| 2.5 | 6SL3210-5FE12-0UA0 |
| 3.5 | 6SL3210-5FE13-5UA0 |
| 5.0 | 6SL3210-5FE15-0UA0 |
| 7.0 | 6SL3210-5FE17-0UA0 |

SIMOTICS S-1FL6 servo motors

| Rated torque (Nm) | Shaft height (mm) | Order number | | | |
|--|-------------------|-----------------|--------------------------|--------------------------|--------------------------|
| 1.27 | 45 | 1FL6042-1AF61-0 | <input type="checkbox"/> | <input type="checkbox"/> | 1 |
| 2.39 | | 1FL6044-1AF61-0 | <input type="checkbox"/> | <input type="checkbox"/> | 1 |
| 3.58 | 65 | 1FL6061-1AC61-0 | <input type="checkbox"/> | <input type="checkbox"/> | 1 |
| 4.78 | | 1FL6062-1AC61-0 | <input type="checkbox"/> | <input type="checkbox"/> | 1 |
| 7.16 | | 1FL6064-1AC61-0 | <input type="checkbox"/> | <input type="checkbox"/> | 1 |
| 8.36 | | 1FL6066-1AC61-0 | <input type="checkbox"/> | <input type="checkbox"/> | 1 |
| 9.55 | | 1FL6067-1AC61-0 | <input type="checkbox"/> | <input type="checkbox"/> | 1 |
| 11.90 | | 90 | 1FL6090-1AC61-0 | <input type="checkbox"/> | <input type="checkbox"/> |
| 16.70 | 1FL6092-1AC61-0 | | <input type="checkbox"/> | <input type="checkbox"/> | 1 |
| 23.90 | 1FL6094-1AC61-0 | | <input type="checkbox"/> | <input type="checkbox"/> | 1 |
| 33.40 | 1FL6096-1AC61-0 | | <input type="checkbox"/> | <input type="checkbox"/> | 1 |
| Incremental encoder | | | | A | |
| Absolute encoder | | | L | | |
| Plain shaft end, without brake | | | | G | |
| Plain shaft end, with brake | | | | H | |
| Half key balanced shaft end, without brake | | | | A | |
| Half key balanced shaft end, with brake | | | | B | |

MOTION-CONNECT 300 cables

| Name | Order number | Length (m) |
|--|--------------------|------------|
| MOTION-CONNECT 300 power cable (for FSAA and FSA) | 6FX3002-5CL01-1AD0 | 3 |
| | 6FX3002-5CL01-1AF0 | 5 |
| | 6FX3002-5CL01-1AH0 | 7 |
| | 6FX3002-5CL01-1BA0 | 10 |
| | 6FX3002-5CL01-1CA0 | 20 |
| MOTION-CONNECT 300 power cable (for FSB and FSC) | 6FX3002-5CL11-1AD0 | 3 |
| | 6FX3002-5CL11-1AF0 | 5 |
| | 6FX3002-5CL11-1AH0 | 7 |
| | 6FX3002-5CL11-1BA0 | 10 |
| | 6FX3002-5CL11-1CA0 | 20 |
| MOTION-CONNECT 300 absolute encoder cable (for absolute encoder) | 6FX3002-2DB10-1AD0 | 3 |
| | 6FX3002-2DB10-1AF0 | 5 |
| | 6FX3002-2DB10-1AH0 | 7 |
| | 6FX3002-2DB10-1BA0 | 10 |
| | 6FX3002-2DB10-1CA0 | 20 |
| MOTION-CONNECT 300 incremental encoder cable (for incremental encoder) | 6FX3002-2CT10-1AD0 | 3 |
| | 6FX3002-2CT10-1AF0 | 5 |
| | 6FX3002-2CT10-1AH0 | 7 |
| | 6FX3002-2CT10-1BA0 | 10 |
| | 6FX3002-2CT10-1CA0 | 20 |
| MOTION-CONNECT 300 brake cable (for holding brake) | 6FX3002-5BL02-1AD0 | 3 |
| | 6FX3002-5BL02-1AF0 | 5 |
| | 6FX3002-5BL02-1AH0 | 7 |
| | 6FX3002-5BL02-1BA0 | 10 |
| | 6FX3002-5BL02-1CA0 | 20 |

Connectors

| Connector | Order number |
|--|---------------|
| Power connector (motor side) | 6FX2003-0LL11 |
| Absolute encoder connector (motor side) | 6FX2003-0DB11 |
| Incremental encoder connector (motor side) | 6FX2003-0SL11 |
| Brake connector (motor side) | 6FX2003-0LL51 |
| Encoder connector (drive side) | 6FX2003-0SB14 |

Cable and connector (between V90 drive and controller)

| Name | Order number | Length (m) |
|--|--------------------|------------|
| Option 1 | | |
| Setpoint connector (50 pins) | 6SL3260-2NA00-0VA0 | - |
| Setpoint cable (50 pins) | 6SL3260-4NA00-1VB0 | 1 |
| Option 2 | | |
| Setpoint cable with terminal block (50 pins) | 6SL3260-4NA00-1VA5 | 0.5 |

User documentation

| Name | Language version | Order number |
|-------------------------------|------------------|--------------------|
| <i>Operating Instructions</i> | English | 6SL3298-0AV60-0BP0 |
| | Chinese | 6SL3298-0AV60-0FP0 |
| | Italian | 6SL3298-0AV60-0CP0 |

A.2 Assembly of cable connectors on the motor side

Power connector assembly

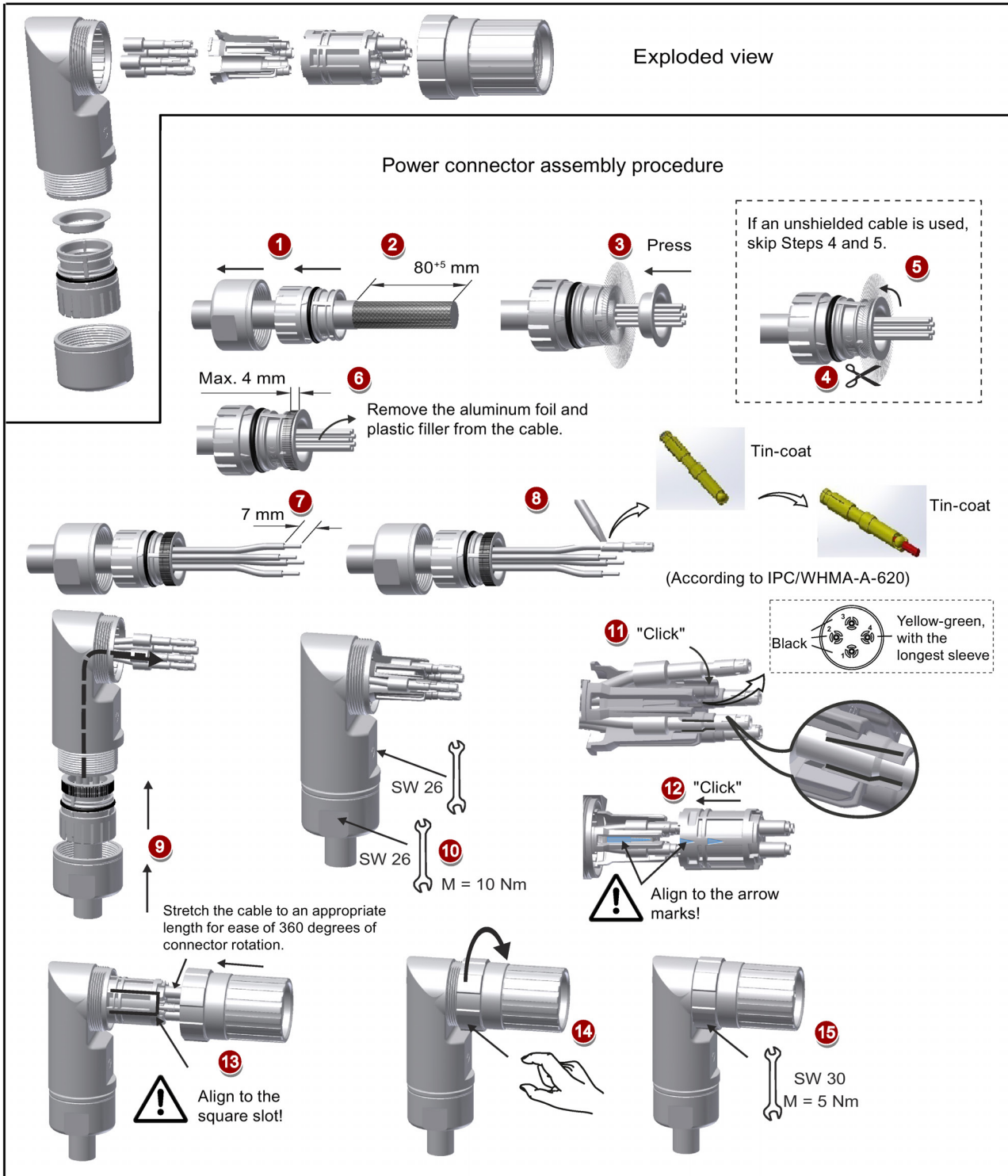

Encoder connector assembly

The connector assembly procedures for incremental and absolute encoders are the same.

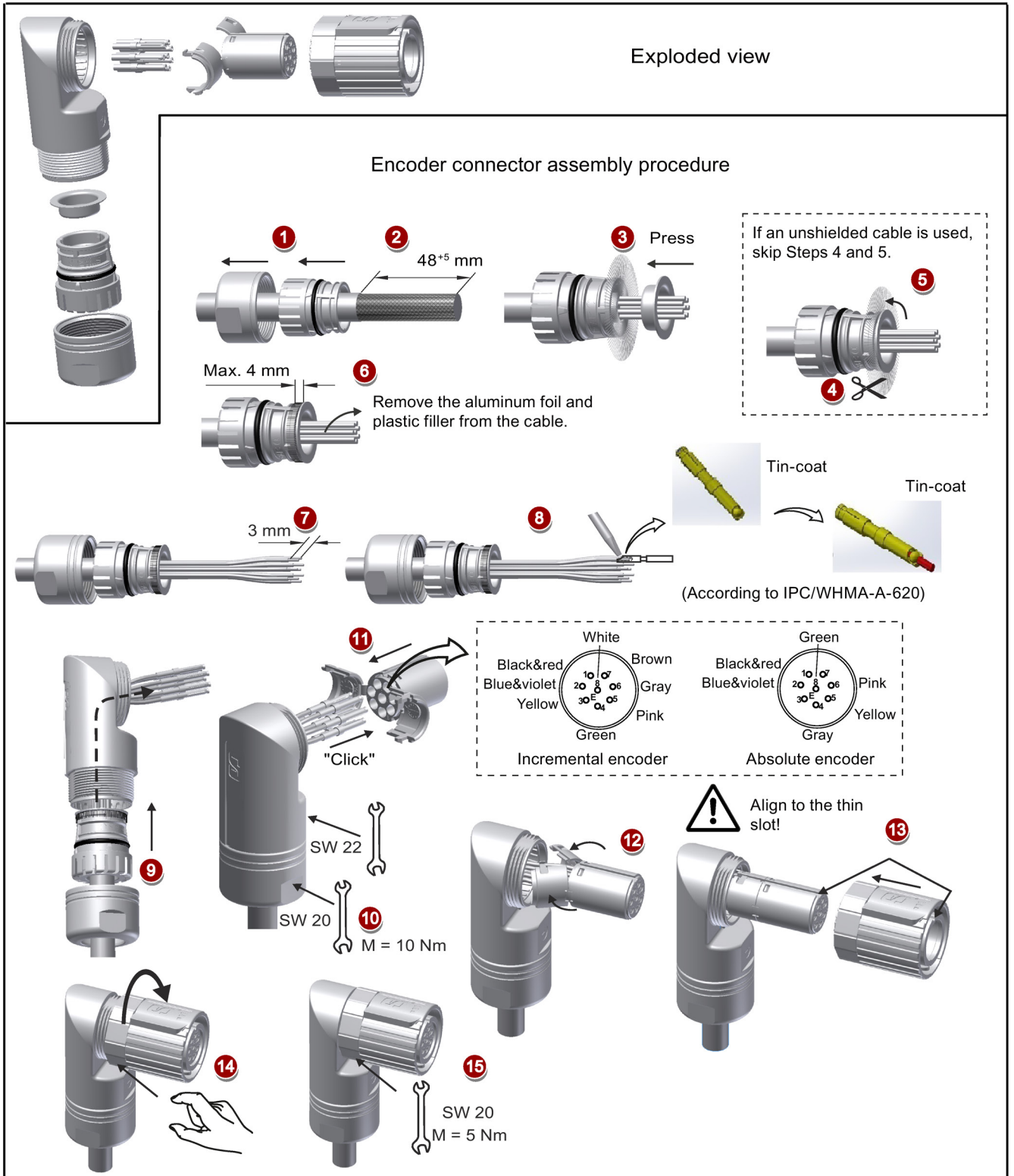

Brake connector assembly

The assembly of a brake connector follows the procedure as described in the figure above for an encoder connector.

A.3 Assembly of cable terminals on the drive side

Power terminal assembly

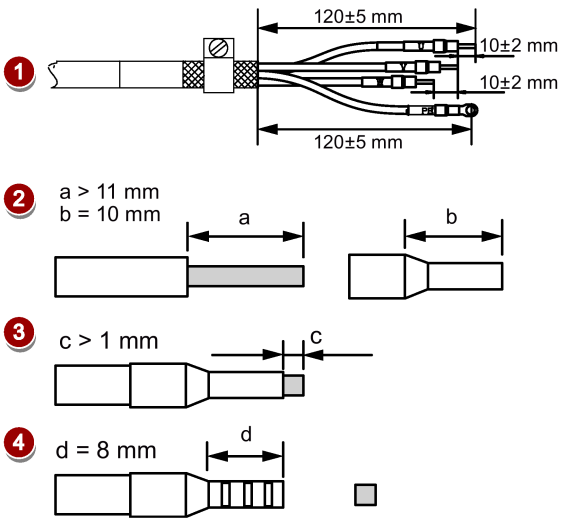
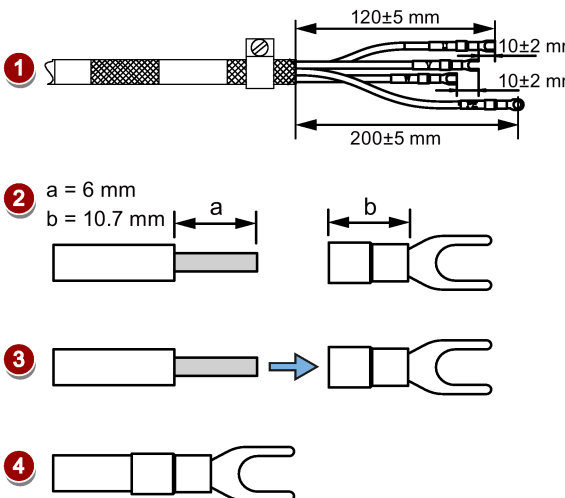
| Drive type | Procedure | Illustration |
|------------|---|--|
| FSA/FSAA | <p>Terminal assembly procedure:</p> <ol style="list-style-type: none"> 1. Remove the outer sheath of the cable. 2. Remove the insulation from the wire. 3. Insert the stripped end into the cable end sleeve. 4. Crimp the cable end sleeve using a crimp tool for end sleeves. |  <p>The illustration shows a cable with a sleeve and four steps of crimping:</p> <ul style="list-style-type: none"> 1. Cable with sleeve, dimensions: 120 ± 5 mm (total length), 10 ± 2 mm (wire length), 10 ± 2 mm (sleeve length). 2. Dimensions: $a > 11$ mm, $b = 10$ mm. 3. Dimension: $c > 1$ mm. 4. Dimension: $d = 8$ mm. |
| FSB/FSC | <p>Terminal assembly procedure:</p> <ol style="list-style-type: none"> 1. Remove the outer sheath of the cable. 2. Remove the insulation from the wire. 3. Insert the stripped end into the spade terminal. 4. Crimp the spade terminal using a crimp tool for cable lugs. (Note: Coat any exposed wires with tin.) |  <p>The illustration shows a cable with a spade terminal and four steps of crimping:</p> <ul style="list-style-type: none"> 1. Cable with spade terminal, dimensions: 120 ± 5 mm (total length), 10 ± 2 mm (wire length), 10 ± 2 mm (spade length), 200 ± 5 mm (total length). 2. Dimensions: $a = 6$ mm, $b = 10.7$ mm. 3. Arrow pointing to the spade terminal. 4. Final assembly with spade terminal. |

Encoder terminal assembly

The terminal assembly procedures for incremental and absolute encoders are the same.

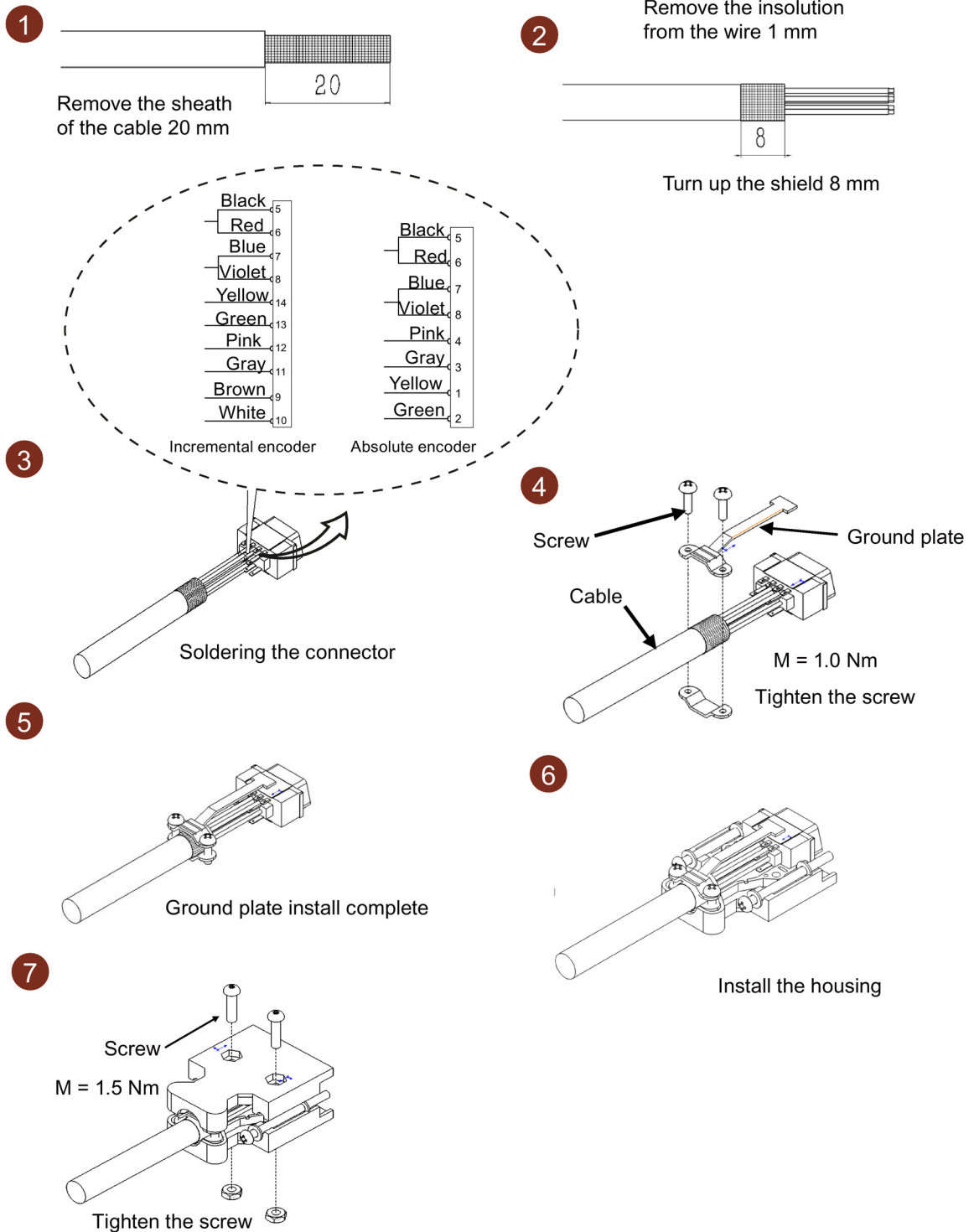

Brake terminal assembly

The assembly of a brake terminal follows the procedure as described in the figure above for a power terminal.

A.4 Motor selection

A.4.1 Selection procedure

1. Determine the mechanism type as well as the detailed data of the related mechanical parts, such as ball screw lead, diameter, lead, and gear diameter. Three mechanism types are shown below:

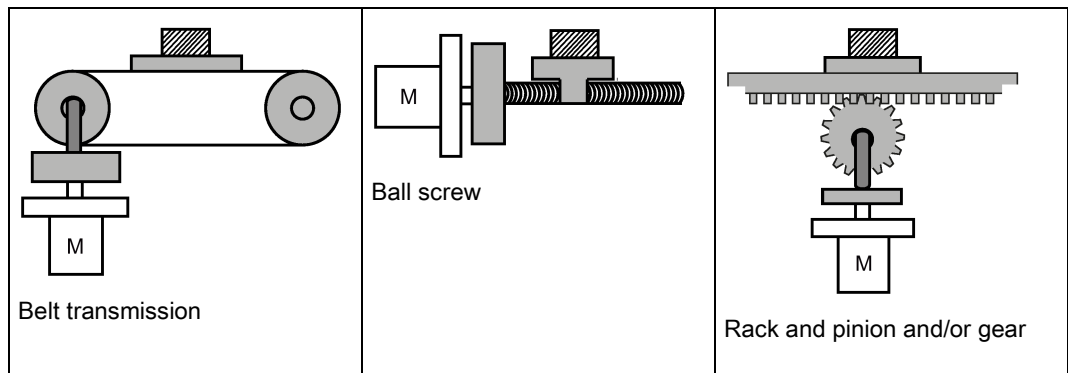

2. Determine the operation pattern including such parameters as acceleration time (t_a), constant motion time (t_u), deceleration time (t_d), stopping time (t_s), cycle time (t_c), and travel distance (L).

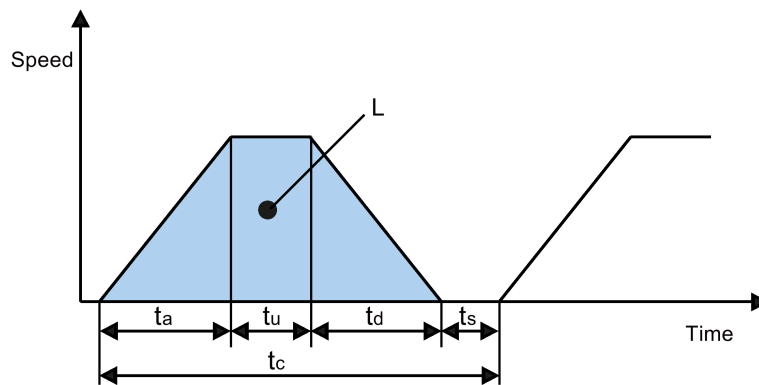

3. Calculate load inertia and inertia ratio.

The inertia ratio can be obtained by dividing the load inertia by the rotor inertia of the selected motor. The unit of inertia is $\times 10^{-4} \text{ kg}\cdot\text{m}^2$.
4. Calculate the speed.

Calculate the speed according to the travel distance, acceleration time, deceleration time, and constant motion time.

5. Calculate the torque.
Calculate the torque according to the load inertia, acceleration time, deceleration time, and constant motion time.
6. Select the motor.
Select the motor that matches the data in step 3 to step 5.

A.4.2 Parameter description

Torque

- Summit torque: It refers to the maximum torque required by a motor in operation, which is generally less than 80% of the motor's maximum torque. When the torque is a negative value, regenerative resistors may be needed.
- Moving torque and hold torque in standstill: It refers to the torque required by a motor in long-term operation, which is generally less than 80% of the motor's rated torque. When the torque is a negative value, regenerative resistors may be needed.
Torque calculation methods of two major mechanism types:

$$T_m = \frac{P_b}{2\pi\eta} (\mu g W + F)$$

W: Mass [kg]

P_b: Ball screw lead [m]

F: External force [N]

η: Mechanical efficiency

μ: Friction coefficient

g: Gravitational acceleration 9.8 [m/s²]

$$T_m = \frac{P_d}{2\eta} (\mu g W + F)$$

W: Mass [kg]

P_d: Belt transmission lead [m]

F: External force [N]

η: Mechanical efficiency

μ: Friction coefficient

g: Gravitational acceleration 9.8 [m/s²]

- Effective torque: It refers to the continuous effective load torque converted into the equivalent value on the servo motor shaft, which is generally less than 80% of the motor's rated torque.

$$T_{rms} = \sqrt{\frac{T_a^2 \times t_a + T_m^2 \times t_u + T_d^2 \times t_d}{t_c}}$$

T_a: Acceleration torque [N·m] t_a: Acceleration time [s]

T_m: Moving torque [N·m] t_u: Constant motion time [s]

T_d: Deceleration torque [N·m] t_d: Deceleration time [s]

t_c: Cycle time [s]

Speed

Maximum speed: It refers to the motor's maximum speed in operation, which is generally lower than the rated speed. When a motor operates at the maximum speed, pay attention to its torque and temperature rise.

Inertia and inertia ratio

Inertia refers to the force required to keep a certain physical state. Inertia ratio indicates dynamic response performance of motors. The smaller the inertia ratio is, the better response performance a motor has.

Typical load inertia equations

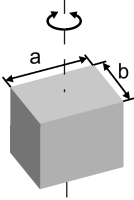
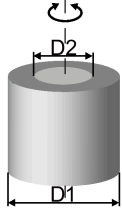
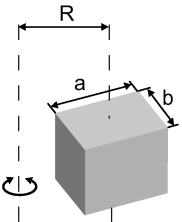
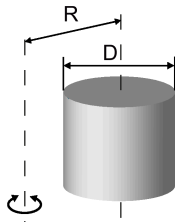
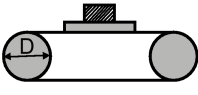
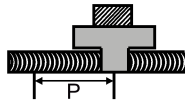
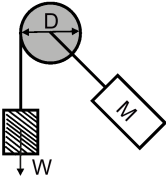
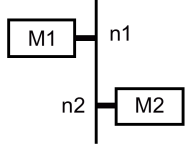
| Mechanism | Equation | Mechanism | Equation |
|--|--|--|--|
|  <p>Axis of rotation on center</p> | $J = \frac{W}{12} (a^2 + b^2)$ <p>W: Mass (kg) a: Length (m) b: Width (m)</p> |  <p>Axis of rotation on center</p> | $J = \frac{W}{8} (D_1^2 + D_2^2)$ <p>W: Mass (kg) D₁: External diameter (m) D₂: Internal diameter (m)</p> |
|  <p>Axis of rotation off center</p> | $J = W \cdot \left(\frac{a^2 + b^2}{3} + R^2 \right)$ <p>W: Mass (kg) a: Length (m) b: Width (m) R: Rotational diameter (m)</p> |  <p>Axis of rotation off center</p> | $J = \frac{W}{8} (D^2 + 8R^2)$ <p>W: Mass (kg) D: Workpiece diameter (m) R: Rotational diameter (m)</p> |
|  <p>Conveyor</p> | $J = \frac{W \cdot D^2}{4}$ <p>W: Mass (kg) D: Pulley wheel diameter (m)</p> |  <p>Ball screw</p> | $J = \frac{W \cdot P^2}{4\pi^2} + J_b$ <p>W: Mass (kg) P: Lead (m) J_b: Ball screw inertia (kg·m²)</p> |
|  <p>Object hung with pulley</p> | $J = W \cdot \left(\frac{D}{2} \right)^2 + J_p$ <p>W: Mass (kg) D: Pulley wheel diameter (m) J_p: Pulley inertia (kg·m²)</p> |  <p>Reducer</p> | $J = J_1 \cdot \frac{n_1^2}{n_2^2} \cdot J_2$ <p>W: Mass (kg) n₁/n₂: Speed of each motor (rpm) J₁/J₂: Inertia of each motor (kg·m²)</p> |

A.4.3 Selection examples

This section uses a ball screw mechanism as an example to illustrate the motor selection procedure.

Exemplary data

The following table lists the data related to the ball screw mechanism and operation pattern.

| Mechanism | | Operation pattern | |
|---|---|--|--------|
| Workpiece weight (W) | 40 kg | Acceleration time (t _a) | 0.15 s |
| Ball screw length (B _l) | 2 m | Constant motion time (t _u) | 0.7 s |
| Ball screw diameter (B _d) | 0.04 m | Deceleration time (t _d) | 0.15 s |
| Ball screw pitch (B _p) | 0.04 m | Cycle time (t _c) | 2 s |
| Mechanical efficiency (B _η) | 0.9 | Travel distance (L) | 0.5 m |
| Coupler inertia (J _c) | 20 x 10 ⁻⁶ kg·m ² (refer to the supplier's product catalog) | - | |

1. **Ball screw weight**

$$B_w = \rho \times \pi \times (B_d/2)^2 \times B_l = 19.85 \text{ kg}$$

2. **Load inertia**

$$J_l = J_c + J_b = J_c + 1/8 \times B_w \times B_d^2 + W \times B_p^2 / 4\pi^2 = 5.61 \times 10^{-3} \text{ kg}\cdot\text{m}^2$$

3. **Preselection**

If a 1000 W motor is selected, J_m (motor inertia) = 1.57 x 10⁻³ kg·m²

Therefore, J_l / J_m (inertia ratio) = 3.57 < 5 times

4. **Maximum rotational speed**

$$V_{\max} \text{ (maximum travelling speed)} = 2L / (t_a + 2t_u + t_d) = 5.89 \text{ m/s}$$

$$N_{\max} \text{ (maximum rotational speed)} = 60 \times V_{\max} / B_p = 882 \text{ rpm} < 2000 \text{ rpm (rated speed)}$$

5. **Effective torque**

$$T_m \text{ (moving torque)} = (\mu g W + F) \times B_p / 2\pi B_\eta = 0.069 \text{ Nm}$$

$$T_a \text{ (acceleration torque)} = [(J_l + J_m) \times 2 \pi N / T_a] + T_m = 4.49 \text{ Nm}$$

$$T_d \text{ (deceleration torque)} = [(J_l + J_m) \times 2 \pi N / T_d] - T_m = 4.35 \text{ Nm}$$

Therefore, T_{rms} (effective torque) = $\sqrt{(T_a^2 \times t_a + T_m^2 \times t_b + T_d^2 \times t_d)} / t_c = 1.71 \text{ Nm} < 4.78 \text{ Nm}$ (rated torque)

6. **Final selection**

According to the above calculated speed, torque, and inertia ratio, you are recommended to select 1000 W motors, i.e. 1FL6062.

A.5 Replacing fans

Proceed as illustrated below to remove the fan from the SINAMICS V90 drive. To re-assemble the fan, proceed in reverse order. When re-assembling the fan for FSC, make sure that the arrow symbol ("A" in the illustration) on the fan points to the drive rather than the fan housing.

Replacing the fans from frame size B

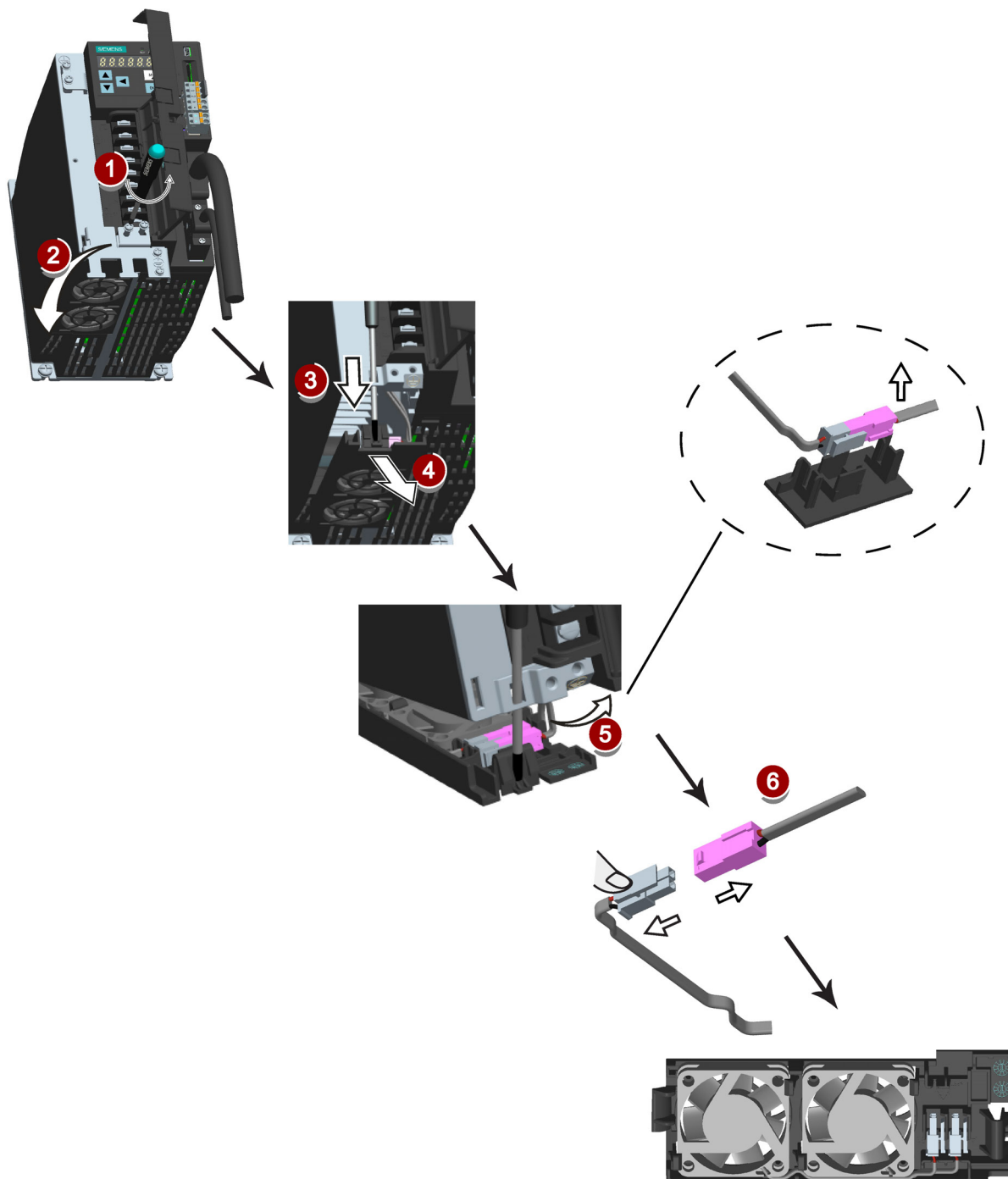

Replacing the fan from frame size C

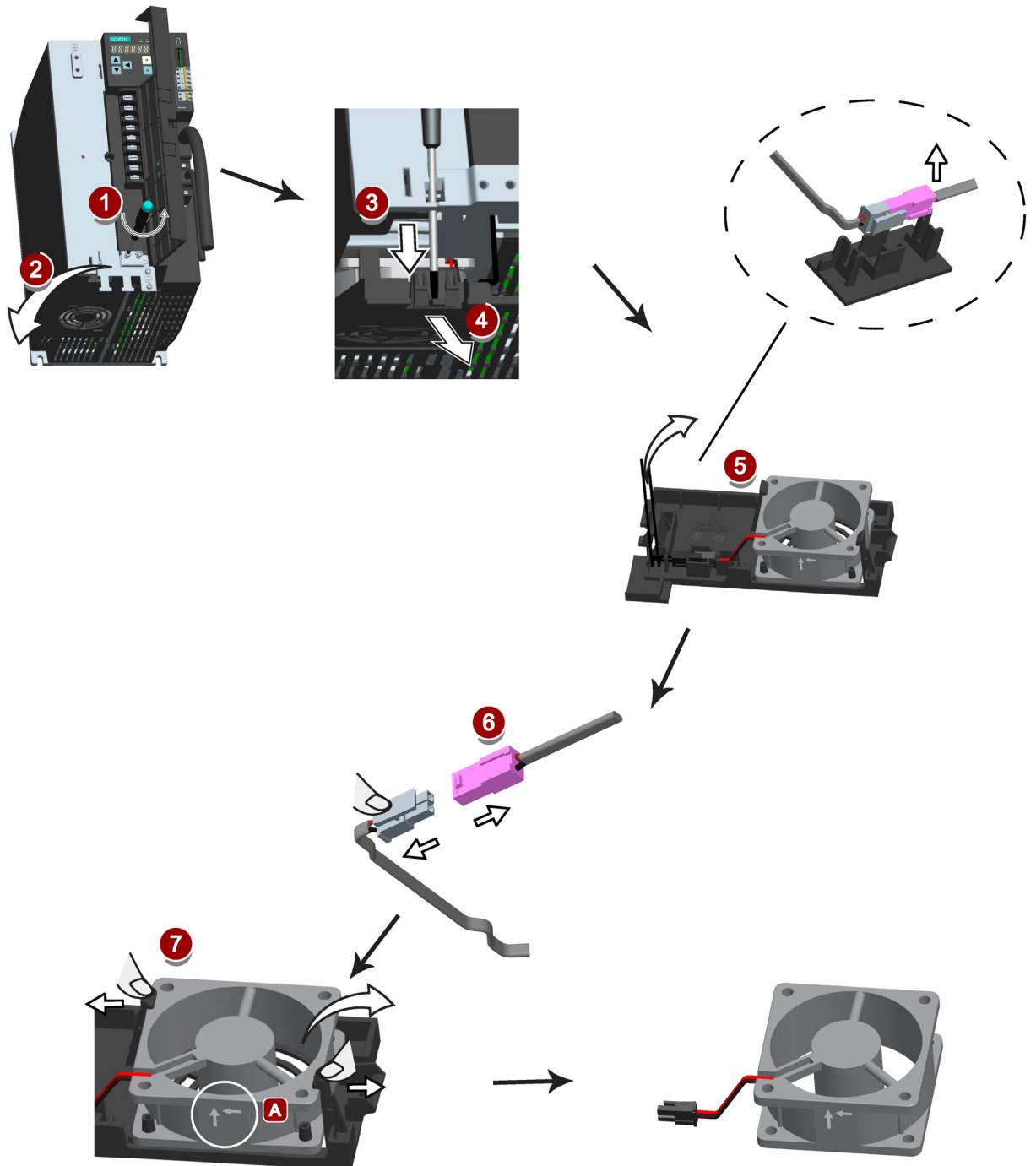

Index

A

- Absolute position system
 - Telegram format, 174
- Accessories
 - Braking resistor, 33
 - Cables and connectors, 31
 - External 24 VDC power supply, 32
 - Filter, 34
 - Fuse/Circuit breaker, 33
 - SD card, 35
- Aims, 177
- Ajust AI offset, 125
- analog inputs, 70
- Analog inputs
 - Command voltage, 71
- analog outputs, 71
- Analog outputs
 - Parameterization, 71
 - Wiring, 72
- ANSI B11, 189

B

- Backlash compensation, 152
- BOP operations
 - Button functions, 112
- BOP operations for faults and alarms, 252
 - Acknowledging faults, 253
 - Exiting from alarm display, 253
 - Exiting from fault display, 252
 - Viewing alarms, 252
 - Viewing faults, 252
- BOP overview, 109

C

- Certification, 191
- Change a parameter value, 116
 - Parameter setting with shift function, 117
- Commissioning
 - SINAMICS V-ASSISTANT, 99
- Connecting 24 V power supply/STO, 93
- Connecting an external braking resistor, 97
- Connecting the RS485 interface, 98

- Connecting the SIMATIC S7-1200
 - For internal position control (IPos), 90
 - For pulse train input position control (PTI), 89
 - For speed control (S), 91
 - For torque control (T), 92
- Connecting the SIMATIC S7-200
 - For internal position control (IPos), 86
 - For pulse train input position control (PTI), 85
 - For speed control, 87
 - For torque control, 88
- Connecting the SIMATIC S7-200 SMART
 - For internal position control (IPos), 82
 - For pulse train input position control (PTI), 81
 - For speed control (S), 83
 - For torque control (T), 84
- Copy parameter set from an SD card to drive, 123
- Copy parameters from the servo drive to an SD card, 122

D

- Device combination, 27
- Differences between faults and alarms, 251
- Digital inputs, 61
 - Direct signal map, 65
 - Wiring, 65
- Digital outputs, 66
 - Assigning warning signals to digital outputs, 68
- DIN EN ISO 13849-1, 182
- Direction of motor rotation, 129
- Drive components, 23
- Drive rating plate, 24

E

- EN 61508, 184
- EN 62061, 183
- Equipment regulations, 190

F

- Function list, 35
- Functional safety, 178

- G**
 - Gain switch, 207
 - Gain switching using actual speed, 211
 - Gain switching using an external digital input signal, 208
 - Gain switching using position deviation, 209
 - Gain switching using position setpoint frequency, 210

- H**
 - Harmonized European Standards, 179

- I**
 - Internal position control mode (IPos)
 - Linear/modular axis, 152
 - Position setpoint, 149
 - Selecting a fixed position setpoint and starting positioning, 162
 - Selecting a positioning mode, 151
 - Setting mechanical system, 148
 - Software position limit, 161

- J**
 - JOG, 100
 - Jog function, 120
 - Jog in speed, 120
 - Jog in torque, 120

- L**
 - LED status indicators, 254

- M**
 - Machine safety in Japan, 190
 - Machine safety in the USA, 187
 - Machinery directive, 179
 - Main circuit wirings
 - Connecting the motor power - U, V, W, 58
 - Motor holding brake, 131
 - DO setting, 132
 - Parameter setting, 133
 - Motor selection method, 278
 - Mounting the motor
 - Motor dimensions, 49
 - Mounting orientation, 49

- N**
 - NFPA 79, 188
 - NRTL, 188

- O**
 - Operating display, 114
 - OSHA, 187
 - Over-travel, 130
 - Overview of absolute position system, 173
 - Restrictions, 173
 - Overview of SINAMICS V90 BOP functions, 119

- P**
 - PI to P switching using torque setpoint, 214
 - PI/P switching, 211
 - PI/P switching using acceleration setpoint, 216
 - PI/P switching using an external digital input signal, 214
 - PI/P switching using pulse deviation, 217
 - PI/P switching using speed setpoint, 215
 - Preface
 - Documentation components, 3
 - Target group, 3
 - Technical support, 3
 - Probability of failure, 192
 - PTO
 - Wiring, 70
 - Pulse train encoder outputs, 70
 - Pulse train input position control mode (PTI)
 - Calculating electronic gear ratio, 138
 - Clearing droop pulses, 146
 - In position (INP), 136
 - P-TRG, 141
 - Selecting a setpoint pulse train input channel, 135
 - Selecting a setpoint pulse train input form, 135
 - Smoothing function, 136
 - Pulse train inputs
 - Wiring, 69

- R**
 - Referencing
 - Referencing modes, 153
 - Residual risk, 187
 - Resonance suppression, 204
 - Manual input of resonance frequency (p29023=0), 206

- One-time resonance frequency search with excitation (p29023=2), 206
 - Real-time resonance suppression (p29023=1), 205
 - Select a resonance suppression mode, 204
 - Response time, 193
 - Risk analysis, 185
 - Risk reduction, 186
- S**
- Safe Torque Off
 - functional features, 193
 - response time, 195
 - selecting/deselecting STO, 195
 - Safety Integrated function, 190
 - Safety of machinery in Europe, 178
 - Save parameters in the servo drive, 121
 - Search a parameter in "P ALL" menu, 118
 - Selection of control mode
 - Control mode change for a compound control mode, 127
 - Control modes, 127
 - Selection of a basic control mode, 127
 - Servo ON signal, 128
 - Relevant parameter settings, 129
 - Set parameter set to default, 122
 - Set zero position, 126
 - Speed control mode
 - Direction and stop, 167
 - External speed setpoint, 165
 - Offset adjustment, 165
 - Parameter settings for fixed speed setpoint, 166
 - Ramp-function generator, 168
 - Speed setpoint, 164
 - Zero speed clamp, 167
 - Speed limit, 142
 - Overall speed limit, 142
 - Standards for implementing safety-related controllers, 181
 - Stopping method at servo OFF, 134
 - Coast-down (OFF2), 134
 - Emergency stop (OFF3), 134
 - Ramp-down (OFF1), 134
 - System connection, 55
- T**
- Technical data
 - Cables, 44
 - servo motors, 39
- Torque control mode
 - 300% overload capacity, 170
 - Direction and stop, 172
 - External analog torque setpoint, 171
 - External speed limit, 143
 - Internal speed limit, 142
 - Offset adjustment, 171
 - Torque control with fixed setpoint, 172
 - Torque setpoint, 171
 - Torque limit, 143
 - External torque limit, 145
 - Internal torque limit, 144
 - Overall torque limit, 144
 - Torque limit reached (TLR), 145
 - Transmitting sequence for the absolute position data, 174
 - Tuning
 - Basic tuning procedure, 200
 - Configuration of dynamic factor, 200
 - Manual tuning, 202
 - Real-time auto tuning, 201
 - Servo gains, 198
 - Tuning methods, 199
 - Tuning with SINAMICS V-ASSISTANT, 199
- U**
- Update firmware, 124
 - Usage of the shielding plate, 56
- W**
- Wiring and connecting
 - Adjusting cable orientations, 57
 - Wiring and connection
 - Connecting the encoder - X9, 94
 - Connecting the motor holding brake - X7, 97