



PowerFlex 755/755T Integrated Safety - Safe Torque Off Option Module

Catalog Numbers 20-750-S3, 20-750-S3-XT



Allen-Bradley

by ROCKWELL AUTOMATION

User Manual

Original Instructions

Important User Information

Read this document and the documents listed in the additional resources section about installation, configuration, and operation of this equipment before you install, configure, operate, or maintain this product. Users are required to familiarize themselves with installation and wiring instructions in addition to requirements of all applicable codes, laws, and standards.

Activities including installation, adjustments, putting into service, use, assembly, disassembly, and maintenance are required to be carried out by suitably trained personnel in accordance with applicable code of practice.

If this equipment is used in a manner not specified by the manufacturer, the protection provided by the equipment may be impaired.

In no event will Rockwell Automation, Inc. be responsible or liable for indirect or consequential damages resulting from the use or application of this equipment.

The examples and diagrams in this manual are included solely for illustrative purposes. Because of the many variables and requirements associated with any particular installation, Rockwell Automation, Inc. cannot assume responsibility or liability for actual use based on the examples and diagrams.

No patent liability is assumed by Rockwell Automation, Inc. with respect to use of information, circuits, equipment, or software described in this manual.

Reproduction of the contents of this manual, in whole or in part, without written permission of Rockwell Automation, Inc., is prohibited.

Throughout this manual, when necessary, we use notes to make you aware of safety considerations.



WARNING: Identifies information about practices or circumstances that can cause an explosion in a hazardous environment, which may lead to personal injury or death, property damage, or economic loss.



ATTENTION: Identifies information about practices or circumstances that can lead to personal injury or death, property damage, or economic loss. Attentions help you identify a hazard, avoid a hazard, and recognize the consequence.

IMPORTANT Identifies information that is critical for successful application and understanding of the product.

These labels may also be on or inside the equipment to provide specific precautions.



SHOCK HAZARD: Labels may be on or inside the equipment, for example, a drive or motor, to alert people that dangerous voltage may be present.



BURN HAZARD: Labels may be on or inside the equipment, for example, a drive or motor, to alert people that surfaces may reach dangerous temperatures.



ARC FLASH HAZARD: Labels may be on or inside the equipment, for example, a motor control center, to alert people to potential Arc Flash. Arc Flash will cause severe injury or death. Wear proper Personal Protective Equipment (PPE). Follow ALL Regulatory requirements for safe work practices and for Personal Protective Equipment (PPE).

The following icon may appear in the text of this document.



Identifies information that is useful and can help to make a process easier to do or easier to understand.

Rockwell Automation recognizes that some of the terms that are currently used in our industry and in this publication are not in alignment with the movement toward inclusive language in technology. We are proactively collaborating with industry peers to find alternatives to such terms and making changes to our products and content. Please excuse the use of such terms in our content while we implement these changes.

	Preface	
	Summary of Changes	7
	Conventions	7
	Terminology	8
	Product Firmware and Release Notes	9
	Additional Resources	9
	Chapter 1	
Safety Concept	What Is the Integrated Safety - Safe Torque Off Option Module?	11
	Compatible Drives	12
	Compatible Safety Controllers	13
	Network Mode	13
	Hardwired Mode	13
	Safety Application Requirements	13
	Safety Certification	13
	Important Safety Considerations	14
	Stop Category Definitions	14
	Performance Level and Safety Integrity Level (SIL) CL3	15
	Functional Proof Tests	15
	PFDavg and PFH Definitions	15
	PFDavg and PFH Data	15
	Safety Reaction Time	16
	Reaction Time in Network STO Mode	16
	Reaction Time in Hardwired STO Mode	16
	Considerations for Safety Ratings	17
	Contact Information If Safety Option Failure Occurs	17
	Chapter 2	
Installation and Wiring	Remove Power from the Drive System	20
	Access the Control Pod	20
	Set the SAFETY and Hardware ENABLE Jumpers	21
	Install the Safety Option Module	22
	Chapter 3	
Configuration	Description of Operation	25
	Out-of-Box State	25
	Recognize Out-of-Box State	26
	Restore the Drive to Out-of-Box State	26
	Chapter 4	
Standard I/O - Network STO Programming and Operation	Description of Integrated Operation	29
	Safe Torque Off Assembly Tags	30
	Configure Safe Torque Off in the Logix Designer Application	31
	Add a PowerFlex 755/755T Drive Product to the Controller Project	32

Add an Option Module to a PowerFlex 755/755T Drive Product in I/O Mode	33
Generate the Safety Network Number (SNN).	33
Configure Safety Connections.	35
Using a 20-750-ENETR Dual-port EtherNet/IP Option Module with a 20-750-S3 Option Module	39
Safety Configuration Signature and Ownership	41
Reset Ownership	41
Safe Torque Off – Stop Category 0 Example Program	41
Safe Torque Off – Stop Category 1 Example Program	42
Falling Edge Reset.	42
Safety Tags in Standard Routines.	43
Standard Tags in Safety Routines (tag mapping)	43
Safe Torque Off Fault Reset	44
Understand Integrated Safety Drive Replacement.	45
Replace an Integrated Safety Drive in a GuardLogix System	45

Integrated Motion – Network STO Programming and Operation

Chapter 5

Requirements	47
Description of Operation	47
Safe Torque Off Assembly Tags	48
Configure Safe Torque Off in the Logix Designer Application.	49
Add a PowerFlex 755 Drive to the Controller Project	50
Configure an Option Card on a PowerFlex 755 Drive in Integrated Motion on EtherNet/IP Network Applications	51
Generate the Safety Network Number (SNN).	52
Configure Safety Connections.	53
Safety Configuration Signature and Ownership	54
Reset Ownership	54
Safe Torque Off – Stop Category 0 Example Program	55
Safe Torque Off – Stop Category 1 Example Program	55
Falling Edge Reset.	56
Safety Tags in Standard Routines.	56
Standard Tags in Safety Routines (tag mapping)	56
STO Fault Reset	57
Troubleshoot the Safe Torque Off Function	58
Understand Integrated Safety Drive Replacement	58
Replace an Integrated Safety Drive in a GuardLogix System	58
Motion Direct Commands in Motion Control Systems.	60

Chapter 6

Hardwired STO Wiring and Operation

Wiring.	67
Cabling	68
Power Supply Requirements	68
Description of Hardwired Operation.	68
Selection of Hardwired Operation.	68
Configure the Drive with Hardwired Safety Connections.	68
Timing Diagrams.	69

	Chapter 7	
Monitoring and Troubleshooting	Monitor STO Status	73
	Module Status Indicator (DS1)	73
	Network Status Indicator (DS2)	74
	Motion Output Status Indicator (DS3)	74
	Monitor STO With a HIM or Software	74
	Fault Messages on HIM, Drive Module, and Connected Components Workbench Software	74
	Safety Supervisor State	77
	Safe Torque Off Faults	77
	Appendix A	
Specifications, Certifications, CE, and UKCA Conformity	Integrated Safety - Safe Torque Off Option Module Specifications	79
	Environmental Specifications	80
	Certifications	81
	Appendix B	
STO Option Module Replacement Considerations	Installation Considerations	83
	Option Module Slots	83
	Wiring	83
	Safe Torque Off Option Module	83
	Integrated Safety - Safe Torque Off Option Module	84
	Appendix C	
Parameter Data	Parameters and Settings in a Linear List	85
	Device Config Parameters	85
	Host Config Parameters	86
	Appendix D	
History of Changes	Change Log	89
	Index	91

Notes:

Topic	Page
Summary of Changes	7
Conventions	7
Terminology	8
Product Firmware and Release Notes	9
Additional Resources	9

This user manual explains how to use PowerFlex® 755 drives and PowerFlex 755T drive products in safety integrity level (SIL) 3, Performance Level (PL) PLe, Category (CAT) 3 applications.

This user manual is intended for people that design, install, configure, or troubleshoot safety applications that use the Integrated Safety - Safe Torque Off option modules

- 20-750-S3 (standard safety option card version)
- 20-750-S3-XT (safety option card version with enhanced corrosive gas protection)

IMPORTANT You must have a basic understanding of electrical circuitry and familiarity with PowerFlex 755 drives and PowerFlex 755T drive products. You must also be trained and experienced in the creation, operation, and maintenance of safety systems.

This user manual describes the safety requirements, including probability of a dangerous failure on demand (PFD_{avg}) and average frequency of a dangerous failure (PFH) values and application verification information (see [PFDavg and PFH Data on page 15](#)).

Rockwell Automation recognizes that some of the terms that are currently used in our industry and in this publication are not in alignment with the movement toward inclusive language in technology. We are proactively collaborating with industry peers to find alternatives to such terms and making changes to our products and content. Please excuse the use of such terms in our content while we implement these changes.

Summary of Changes

This manual contains new and updated information as indicated in the following table.

Topic	Page
PowerFlex 755TR liquid cooled drive, frame 7L added to Table 2.	16
PowerFlex 755TR liquid cooled drive, frame 7L added to Table 4.	17

Conventions

This manual lists parameter names followed by the number in brackets. For example, STO Fault Type [P7]. Both Host Config and Device Config parameters exist for this option module and the parameter numbers overlap. For example, there is a Device Config Identity Status [P1], and a Host Config Guard Status [P1].

Throughout this manual, the PowerFlex 755 Integrated Safety - Safe Torque Off option module is also referred to as the Integrated Safety - Safe Torque Off option module. Throughout this manual, the PowerFlex 755TL low harmonic drives, PowerFlex 755TR regenerative drives, PowerFlex 755TS drives, and PowerFlex 755TM drive systems are also referred to as PowerFlex 755T drive products. The PowerFlex 755 drive is used for the examples in this manual.

[Table on page 8](#) defines the abbreviations that are used in this manual.

Terminology

Abbreviations and Definitions

Abbreviation	Full Term	Definition
1oo2	One out of Two	Refers to the behavioral design of a dual-channel safety system.
CAT	Category	Classification of the safety-related parts of a control system in respect of their resistance to faults and their subsequent behavior in the fault condition, and which is achieved by the structural arrangement of the parts, fault detection, and/or by their reliability (source ISO 13849).
CL	Claim Limit	The maximum SIL rating that can be claimed for a safety-related electrical control system subsystem in relation to architectural constraints and systematic safety integrity (source IEC 62061).
DeviceID	Device ID	A unique identifier, comprised of the module number and SNN, to make sure that duplicate module numbers do not compromise communication between the correct safety devices.
EN	European Norm	The official European Standard.
ESD	Emergency Shutdown Systems	A system, usually independent of the main control system, which is designed to safely shut down an operating system.
ESPE	Electro-sensitive Protective Equipment	An assembly of devices and/or components working together for protective tripping or presence-sensing purposes and includes as a minimum: <ul style="list-style-type: none"> • A sensing device. • Controlling/monitoring devices. • Output signal-switching devices (OSSD).
HFT	Hardware Fault Tolerance	The HFT equals n , where $n+1$ faults could cause the loss of the safety function. An HFT of one means that two faults are required before safety is lost.
HIM	Human Interface Module	A module that is used to configure a device.
IEC	International Electrotechnical Commission	The International Electrotechnical Commission (IEC) is the organization that prepares and publishes international standards for all electrical, electronic, and related technologies.
IGBT	Insulated Gate Bipolar Transistors	Typical power switch that is used to control main current.
ISO	International Organization for Standardization	The International Organization for Standardization is an international standard-setting body that is composed of representatives from various national standards organizations.
NC	Normally Closed	A set of contacts on a relay or switch that are closed when the relay is de-energized or the switch is de-activated.
NO	Normally Open	A set of contacts on a relay or switch that are open when the relay is de-energized or the switch is de-activated.
OSSD	Output Signal Switching Device	The component of the electro-sensitive protective equipment (ESPE) connected to the control system of a machine. When the sensing device is actuated during normal operation, the device responds by going to the OFF-state.
PELV	Protective Extra Low Voltage	An electrical system where the voltage cannot exceed ELV under normal conditions, and under single-fault conditions, except earth faults in other circuits.
PFD_{avg}	Probability of a Dangerous Failure on Demand	The average probability of a system to fail to perform its design function on demand.
PFH	Average Frequency of a Dangerous Failure per hour	The average frequency of a system to have a dangerous failure occur per hour.
PL	Performance Level	EN ISO 13849-1 safety rating
PM	Permanent Magnet	In permanent magnet (PM) motors, magnets mounted on or embedded in the rotor, couple with the current-induced internal magnetic fields of the motor generated by electrical input to the stator.
SELV	Safety Extra Low Voltage Circuit	A secondary circuit that is designed and protected so that, under normal and single fault conditions, its voltages do not exceed a safe value.
SIL	Safety Integrity Level	A measure of a products ability to lower the risk that a dangerous failure could occur.
SSN	Safety Network Number	A unique number that identifies a section of a safety network.
STO	Safe Torque Off	The Safe Torque Off (STO) function is used to help prevent unexpected motor rotation during an emergency while the drive remains connected to the power supply. When STO is activated, the torque power cannot reach the drive, which stops and helps prevent any motor shaft rotation.

Product Firmware and Release Notes

Product firmware and release notes are available online within the Product Compatibility and Download Center.

1. Go to rok.auto/pcdc.
2. Search for your product.

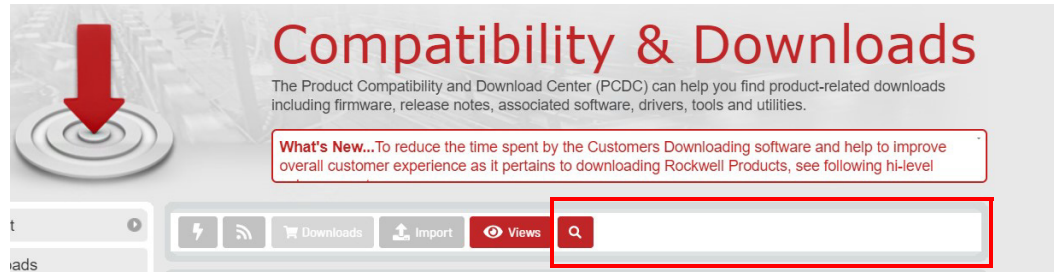

3. On the search results page, find the firmware and release notes for your product. If no firmware/release notes are available, the module is still shipping with its original firmware release.

Additional Resources

These documents contain additional information concerning related Rockwell Automation products.

Resource	Description
PowerFlex 750-Series Products with TotalFORCE® Control Installation Instructions, publication 750-IN100	Provides the basic steps to install PowerFlex 755TL low harmonic drives, PowerFlex 755TR regenerative drives, and PowerFlex 755TM drive systems.
PowerFlex 755TM IP00 Open Type Kits Installation Instructions, publication 750-IN101	Provides instructions to install IP00 Open Type kits in user-supplied enclosures.
PowerFlex Drives with TotalFORCE Control Programming Manual, publication 750-PM100	Provides detailed information on: <ul style="list-style-type: none"> • I/O, control, and feedback options • Parameters and programming • Faults, alarms, and troubleshooting
PowerFlex 750-Series AC Drive Installation Instructions, publication 750-IN001	Provides information on how to install the Safe Torque Off option module in a PowerFlex 750-Series drive.
PowerFlex 755TS Products with TotalFORCE Control Installation Instructions, publication 750-IN119	Provides the basic steps to install PowerFlex 755TS drives.
PowerFlex 750-Series AC Drives Programming Manual, publication 750-PM001	Provides information on how to mount, install, and configure PowerFlex 750-Series drives.
Enhanced PowerFlex 7-Class Human Interface Module (HIM) User Manual, publication 20HIM-UM001	Provides information for using the 20-HIM-A6 HIM to configure PowerFlex 750-Series drives and the Safe Torque Off option module.
Connected Components Workbench Online Help	Online Help that provides a description of the different elements of the Connected Components Workbench™ software.
GuardLogix 5570 and Compact GuardLogix 5370 Controller Systems Safety Reference Manual, publication 1756-RM099	Provides information on safety application requirements for GuardLogix® 5570 and Compact GuardLogix 5370 controllers in Studio 5000 Logix Designer® applications. Also provides details on how to calculate system reaction times.
System Design for Control of Electrical Noise Reference Manual, publication 6MC-RM001	Information, examples, and techniques that are designed to minimize system failures caused by electrical noise.
Safety Guidelines for the Application, Installation, and Maintenance of Solid-State Control, publication SGI-1.1	Describes important differences between solid-state control and hardwired electromechanical devices.
GuardLogix 5580 and Compact GuardLogix 5380 Controller Systems Safety Reference, publication 1756-RM012	Provides information on safety application requirements for GuardLogix 5580 and Compact GuardLogix 5380 controllers in Studio 5000 Logix Designer applications. Also provides details on how to calculate system reaction times.
GuardLogix 5570 Controllers User Manual, publication 1756-UM022	Provides information on how to use standard Guard Logix 5570 controllers.
ControlLogix 5580 Controllers User Manual, publication 1756-UM543	Provides information on how to use standard ControlLogix® 5580 controllers.

Resource	Description
Compact GuardLogix 5370 Controllers User Manual, publication 1769-UM022	Provides information on how to use Compact GuardLogix 5370 controllers.
CompactLogix 5380 and Compact GuardLogix 5380 Controllers User Manual, publication 5069-UM001	Provides information on how to use CompactLogix™ 5380 and Compact GuardLogix 5380 controllers.
Product Certifications website, rok.auto/certifications	Provides declarations of conformity, certificates, and other certification details

You can view or download publications at rok.auto/literature.

Safety Concept

This chapter provides information on safety considerations for the Integrated Safety - Safe Torque Off option module.

Topic	Page
What Is the Integrated Safety - Safe Torque Off Option Module?	11
Compatible Drives	12
Compatible Safety Controllers	13
Safety Application Requirements	13
Safety Certification	13
Functional Proof Tests	15
PFDavg and PFH Definitions	15
PFDavg and PFH Data	15
Safety Reaction Time	16
Considerations for Safety Ratings	17
Contact Information If Safety Option Failure Occurs	17

What Is the Integrated Safety - Safe Torque Off Option Module?

The Integrated Safety - Safe Torque Off (STO) option module provides either a hardwired or a networked STO function via an EtherNet/IP® network. See [Chapter 6](#) for detailed information on hardwired operation.

With networked Safe Torque Off, a GuardLogix® safety controller issues the Safe Torque Off command over the EtherNet/IP network, and the PowerFlex® drive executes the command. The Integrated Safety - Safe Torque Off option module includes these features:

- Is designed to remove power from the gate firing circuits of the drive output power devices (IGBTs). With the power removed, the drive output power devices cannot turn on to generate AC power to the motor.
- Can be used in combination with other safety devices to satisfy the requirements of IEC 61508, EN/IEC 61800-5-2 SIL 3, ISO 13849-1 PL_e, and Category 3 for Safe Torque Off (STO).

IMPORTANT The Integrated Safety - Safe Torque Off option module is suitable for performing mechanical work on the drive train or affected area of a machine only. It does not provide electrical safety.

IMPORTANT The Integrated Safety - Safe Torque Off option module does not remove dangerous voltages at the drive output. Before performing any electrical work on the drive or motor, turn off the input power to the drive, and follow all safety procedures. See [Remove Power from the Drive System on page 20](#) for more information.

-
- IMPORTANT** You cannot install multiple safety option modules simultaneously. Only one of these safety option modules can be installed in the drive:
- PowerFlex 750-Series Safe Torque Off option module (catalog numbers 20-750-S, 20-750-S-XT)
 - PowerFlex 750-Series Safe Speed Monitor option module (catalog numbers 20-750-S1, 20-750-S1-XT)
 - PowerFlex 755 Integrated Safety - Safe Torque Off option module (catalog numbers 20-750-S3, 20-750-S3-XT)
 - PowerFlex 755 Integrated Safety Functions option module (catalog numbers 20-750-S4, 20-750-S4-XT)
-



ATTENTION: If two output IGBTs fail in the drive, when the Integrated Safety - Safe Torque Off option module has controlled the drive outputs to the Off state, the drive can provide stored energy for up to 180° of rotation in a 2-pole motor before torque production in the motor stops.



ATTENTION: The STO function only disables motor torque. A mechanical force on the motor shaft, such as suspended loads or back pressure in a pump or fan, can cause motor rotation.

-
- IMPORTANT** Do not use this option module as a control for starting or stopping the drive.
-

Compatible Drives

The Integrated Safety - Safe Torque Off option module is compatible with these PowerFlex 755 drives and PowerFlex 755T drive products:

- PowerFlex 755 drives (firmware revision 13 or later)
- PowerFlex 755TL low harmonic drives
- PowerFlex 755TR regenerative drives
- PowerFlex 755TM drive systems
- PowerFlex 755TS low power drives

Integrated STO is via the embedded Ethernet port on the drive only. Device Level Ring (DLR) capability is supported for the PowerFlex 755 when a 20-750-ENETR Dual Port EtherNet/IP option module is used in Tap mode. The PowerFlex 755T has DLR capability standard with its two embedded Ethernet ports.

-
- IMPORTANT** The Integrated Safety - Safe Torque Off option module is not compatible with PowerFlex 753 drives.
-

For use with the Studio 5000 Logix Designer® application, you need the following drive Add-on Profiles (AOPs) for I/O mode:

- For PowerFlex 755 drives, AOP version 4.09 (or later)
- For PowerFlex 755T drive products, all AOP versions
- For PowerFlex 755TS drive products, AOP version 15.01 (or later)

The following Integrated Motion AOPs are needed:

- For PowerFlex 755 drives, Integrated Motion AOP version 18.00.00 (or later)
- PowerFlex 755T drive products do not support Integrated Motion at this time.

Compatible Safety Controllers

Network Mode

A GuardLogix safety controller is required for use of the Integrated Safety - Safe Torque Off option module that is used in Network mode control ('Safety', 'Standard and Safety', or 'Motion and Safety' used for Connection type). The following GuardLogix controllers may be used:

Controller	Controller Firmware Revision	Studio 5000 Logix Designer Version
GuardLogix 5570 safety controller	30.00	30.00.00
GuardLogix 5580 safety controller	31.00	31.00.00
Compact GuardLogix 5370 safety controller	30.00	30.00.00
Compact GuardLogix 5380 safety controller	31.00	31.00.00

IMPORTANT Integrated Motion support of the Integrated Safety - Safe Torque Off option module (catalog number 20-750-S3) is only available with GuardLogix 5580 and Compact GuardLogix 5380 safety controllers.

The GuardLogix 5570 controller requires a 1756 EtherNet/IP adapter for network communication, but the other controllers have built-in EtherNet/IP ports. See the user and safety reference manuals listed in [Additional Resources on page 9](#) for details on using these controllers.

Hardwired Mode

Various safety controllers or other safety devices can be used with the Integrated Safety - Safe Torque Off option module when it is used in Hardwired mode control.

Safety Application Requirements

Create, record, and verify the safety signature as part of the required safety application development process. The safety controller creates the safety signature. The safety signature consists of an identification number, date, and time that uniquely identifies the safety portion of a project. This signature covers all safety logic, data, and safety I/O configuration.

For safety system requirements, including information on the safety network number (SNN), verifying the safety signature, and functional verification tests, see the GuardLogix Controller Systems Safety Reference Manuals listed in the [Additional Resources on page 9](#).

Safety Certification

The PowerFlex 755 Integrated Safety - Safe Torque Off option module (catalog number 20-750-S3) is certified by TÜV Rheinland as suitable for use in hardwired or integrated safety applications:

- Up to and including SIL 3 according to EN 62061/IEC 61508
- Up to and including SIL CL3 according to EN/IEC 61800-5-2/ EN 62061/IEC 61508
- Up to and including Performance Level PL_e (Category 3) according to EN ISO 13849-1.

In these applications, the removal of motion-producing power is considered to be the safe state.

All components in the system must be chosen and applied correctly to achieve the desired level of operator safeguarding.

Important Safety Considerations

You are responsible for these system safety considerations:

- Set-up, safety rating, and validation of any sensors or actuators connected to the system.
- Complete a system-level risk assessment, and reassess the system any time a change is made.
- Certification of the system to the desired safety Performance Level.
- Project management and proof testing.
- Programming the application software and the safety option module configurations in accordance with the information in this manual.
- Access control to the system.
- Analyze all configuration settings and choose the proper setting to achieve the required safety rating.

IMPORTANT Only qualified, authorized personnel that are trained and experienced in functional safety can plan, implement, and apply functional safety systems.



ATTENTION: When designing your system, consider how personnel exit the machine if the door locks while they are in the machine. Additional safeguard devices can be required for your specific application.



ATTENTION: In circumstances where external influences (for example, suspended loads that can fall) are present, additional measures (for example, mechanical brakes) can be necessary to help prevent any hazard.

Stop Category Definitions

Perform a risk assessment to select a stop category for each stop function:

- Stop Category 0 is achieved with immediate removal of power to the machine actuators, which results in an uncontrolled coast-to-stop. Safe Torque Off accomplishes a Stop Category 0 stop. See [Safe Torque Off – Stop Category 0 Example Program on page 55](#).
- Stop Category 1 is achieved with a ramp to stop followed with immediate removal of power to the machine actuators. Additional logic is required in the safety task and main program for this stop function. See [Safe Torque Off – Stop Category 1 Example Program on page 55](#).

IMPORTANT The Integrated Safety - Safe Torque Off option module does not directly support Stop Category 2. Stop Category 2 is a controlled stop with power left available to the machine actuators.

IMPORTANT When designing the machine application, consider timing and distance for a coast-to-stop (Stop Category 0 or Safe Torque Off). For more information on stop categories and Safe Torque Off, see EN 60204-1 and EN 61800-5-2.

Performance Level and Safety Integrity Level (SIL) CL3

For safety-related control systems, Performance Level (PL), according to ISO 13849-1, and SIL levels, according to IEC 61508 and EN 62061, include a rating of the ability of the system to perform its safety functions. All safety-related components of the control system must be included in both a risk assessment and the determination of the achieved levels.

See the ISO 13849-1, IEC 61508, and EN 62061 standards for complete information on requirements for PL and SIL determination.

Functional Proof Tests

The functional safety standards require that functional proof tests be performed on the equipment that is used in the system. Proof tests are performed at user-defined intervals and are dependent upon PFD and PFH values.

IMPORTANT The time frame for the proof test interval depends on the specific application.

PFD_{avg} and PFH Definitions

Safety-related systems can be classified as operating in either a Low Demand mode, or in a High Demand/Continuous mode.

- Low Demand mode: where the frequency of demands for operation, made on a safety-related system, is no greater than one per year, or no greater than twice the proof test frequency.
- High Demand/Continuous mode: where the frequency of demands for operation, made on a safety-related system, is greater than once per year, or greater than twice the proof test interval.

The SIL value for a low-demand safety-related system is directly related to order-of-magnitude ranges of its average probability of failure to perform its safety function on demand or, simply, the probability of a dangerous failure on demand (PFD_{avg}).

The SIL value for a High Demand/Continuous mode safety-related system is directly related to the average frequency of a dangerous failure (PFH) per hour.

PFD_{avg} and PFH Data

These PFD_{avg} and PFH calculations are based on the equations from Part 6 of EN 61508 and show worst-case values.

This table provides data for a 20-year proof test interval and demonstrates the worst-case effect of various configuration changes on the data.

Table 1 - PFD_{avg} and PFH for PowerFlex 755 Drives

Attribute	Frames 1...7	Frame 8	Frame 9	Frame 10
PFD _(average)	1.44E-4	2.84E-4	3.76E-4	4.67E-4
PFH (1/hour)	1.79E-9	3.41E-9	4.46E-9	5.51E-9
SIL	3	3	3	3
PL	e	e	e	e
Category	3	3	3	3
MTTF _D years	193.4 (high)	91.0 (high)	67.8 (high)	54.3 (high)
DC _{avg} %	90.3% (medium)	94.1% (high)	95.0% (high)	95.5% (high)
HFT	1(1002)	1(1002)	1(1002)	1(1002)
Mission time	20 years	20 years	20 years	20 years

Table 2 - PFD and PFH for PowerFlex 755T Drive Products

Attribute	Frames 5, 6, and 6L	Frames 7, 7L, and 8	Frame 9	Frame 10	Frame 11	Frame 12	Frame 13	Frame 14	Frame 15
PFD _(average)	1.48E-4	3.59E-4	3.85E-4	4.11E-4	4.37E-4	4.63E-4	4.89 E-4	5.41 E-4	5.93 E-4
PFH (1/hour)	1.84E-9	4.28E-9	4.57E-9	4.87E-9	5.17E-9	5.47E-9	5.76 E-9	6.36 E-9	6.96 E-9
SIL	3	3	3	3	3	3	3	3	3
PL	e	e	e	e	e	e	e	e	e
Category	3	3	3	3	3	3	3	3	3
MTTF _D years	178.4 (high)	99.9 (high)	85.7 (high)	75.1 (high)	66.8 (high)	60.2 (high)	54.8 (high)	46.4 (high)	40.2 (high)
DC _{avg} %	90.7% (medium)	93.3% (medium)	93.8% (medium)	94.2% (high)	94.5% (high)	94.7% (high)	94.9% (high)	95.2% (high)	95.4% (high)
HFT	1(1002)	1(1002)	1(1002)	1(1002)	1(1002)	1(1002)	1(1002)	1(1002)	1(1002)
Mission time	20 years	20 years	20 years	20 years	20 years	20 years	20 years	20 years	20 years

Table 3 - PFDavg and PFH for PowerFlex 755TS Drive Products

Attribute	Frames 1...7, and 7A
PFD _(average)	1.44E-04
PFH (1/hour)	1.79E-09
SIL	3
PL	e
Category	3
MTTF _D years	191.7
DC _{avg} %	90.4 (medium)
HFT	1(1002)
Mission time	20 years

Safety Reaction Time

The safety reaction time is the length of time from a safety-related event as input to the system until the system is in the safe state.

[Table 4 on page 17](#) shows the safety reaction time from an input signal condition that triggers a safe stop, to the initiation of the configured Stop Type.

Reaction Time in Network STO Mode

Reaction Time in Network STO Mode is the delay between the time when the drive STO function receives the STO request, and when power that produces the motion is removed from the motor.

Reaction Time in Hardwired STO Mode

Reaction time in hardwired STO mode is a combination of the STO hardwired input reaction time and STO reaction time.

For details on how to calculate system reaction times with GuardLogix controllers, see the GuardLogix Controller Systems Safety Reference Manuals listed in the [Additional Resources on page 9](#).

Table 4 - Safety Reaction Time

Drive Product	Network STO Reaction Time, Max	Hardwired STO Reaction Time, Max
PowerFlex 755 drives (firmware revision 13 or later) Frames 1...10	15 ms	25 ms
PowerFlex 755TL drives, PowerFlex 755TR drives, PowerFlex 755TM drive systems Frames 7...15		
PowerFlex 755TR drives Frame 7L		
PowerFlex 755TS drives Frames 1...7, and 7A	26 ms	36 ms
PowerFlex 755TL drives Frames 5 and 6		
PowerFlex 755TR drives Frames 5, 6, and 6L		

IMPORTANT An input signal condition that is present for less than the reaction time may not result in the safety function being performed. Repeated requests of the safety function for less than the reaction time can result in a spurious detection of a fault.

IMPORTANT In network STO Mode, the safety reaction time in [Table 4 on page 17](#) does not include the connection reaction time limit. See the GuardLogix Controller Systems Safety Reference Manuals, listed in the [Additional Resources on page 9](#), for details.

Considerations for Safety Ratings

The achievable safety rating of an application that uses the Integrated Safety - Safe Torque Off option module that is installed in PowerFlex 755 drives (firmware revision 13 or later), and PowerFlex 755T drive products are dependent upon many factors, drive options, and the type of motor.

For applications that immediately remove power to the actuator, which results in an uncontrolled coast-to-stop, a safety rating up to and including SIL CL3, PL e, and Category 3 can be achieved.

Contact Information If Safety Option Failure Occurs

If you experience a failure with any safety-certified device, contact your local Rockwell Automation sales office or Allen-Bradley® distributor. With this contact, you can do the following:

- Return the device to Rockwell Automation so the failure is appropriately logged for the catalog number that is affected and a record is made of the failure.
- Request a failure analysis (if necessary) to determine the probable cause of the failure.

Notes:

Installation and Wiring

This chapter provides installation, jumper settings, and wiring for the Integrated Safety - Safe Torque Off option module.

Topic	Page
Remove Power from the Drive System	20
Access the Control Pod	20
Set the SAFETY and Hardware ENABLE Jumpers	21
Install the Safety Option Module	22



ATTENTION: The following information is a guide for proper installation. Rockwell Automation does not assume responsibility for the compliance or the noncompliance to any code, national, local, or otherwise for the proper installation of this equipment. A hazard of personal injury and/or equipment damage exists if codes are ignored during installation.

IMPORTANT

Installation must be in accordance with the instructions in this user manual and the installation instructions for your drive.

Only qualified, authorized personnel that are trained and experienced in functional safety can plan, implement, and apply functional safety systems.

IMPORTANT

During installation and maintenance, check your drive firmware release notes for known anomalies and verify that there are not safety-related anomalies.

The Integrated Safety - Safe Torque Off option module is intended to be part of the safety-related control system. Before installation, perform a risk assessment that compares the Integrated Safety - Safe Torque Off option module specifications and all foreseeable operational and environmental characteristics of the control system.

A safety analysis is required to determine how often to test the safety function for proper operation during the life of the machine.

Remove Power from the Drive System

Before performing any work on the drive, remove all power to the system.



ATTENTION:

- Electrical Shock Hazard. Verify that all sources of AC and DC power are de-energized and locked out or tagged out in accordance with the requirements of ANSI/NFPA 70E, Part II.
- To avoid an electric shock hazard, verify that the voltage on the bus capacitors has discharged before performing any work on the drive. Measure the DC bus voltage at the +DC and -DC terminals or test points. The voltage must be zero. For the location of the terminal block and test point sockets, see the manual for your drive:
 - PowerFlex® 750-Series AC Drive Installation Instructions, publication [750-IN001](#)
 - PowerFlex 750-Series Products with TotalFORCE™ Control Installation Instructions, publication [750-IN100](#)
 - PowerFlex 755TM IP00 Open Type Kits Installation Instructions, publication [750-IN101](#)
 - PowerFlex 755TS Products with TotalFORCE Control Installation Instructions, publication [750-IN119](#)
- In Safe Torque Off mode, hazardous voltages may still be present at the motor. To avoid an electric shock hazard, disconnect power to the motor and verify that the voltage is zero before performing any work on the motor.

Access the Control Pod

The option module is installed in the drive control pod. Different drives have different ways to access the control pod.

To access the control pod, follow these steps.

1. Remove the door or cover.
2. Loosen the retention screw on the HIM cradle.
3. Lift the cradle until the latch engages.

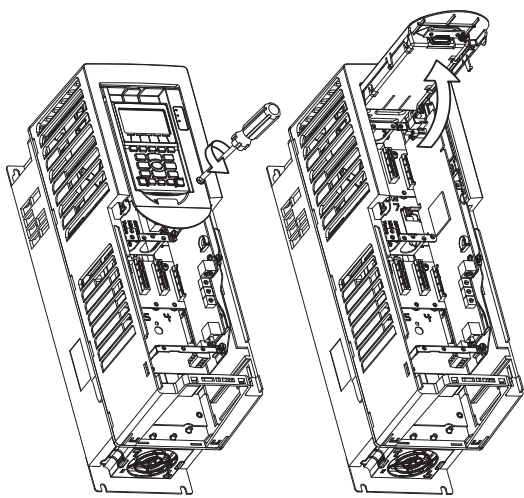

Panel-mounted Drives

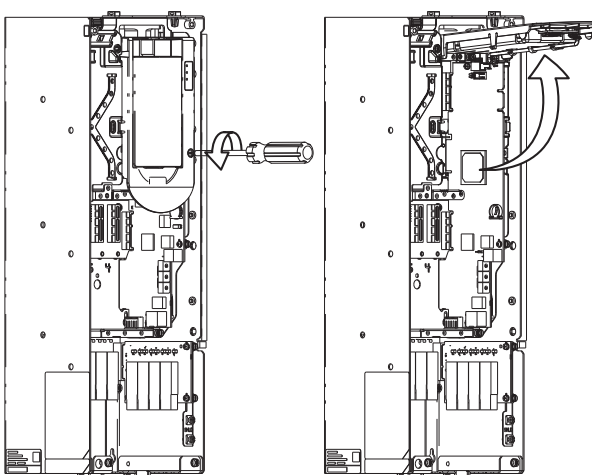

Drives in Cabinet Enclosures

See the installation instructions for your drive for more information.

Set the SAFETY and Hardware ENABLE Jumpers

The drive ships with the SAFETY enable jumper and the hardware ENABLE jumper installed. Both of these jumpers are on the main control board.

IMPORTANT PowerFlex 755 drives (frames 8...10) control boards do not have a SAFETY enable jumper.

To configure the product to use the PowerFlex 755/755T Integrated Safety - Safe Torque Off option module, complete the following steps.

1. Access the control pod.
2. Locate and remove the SAFETY enable jumper on the main control board.
If the SAFETY enable jumper is installed when using a safety option the drive will fault.
3. Locate and make sure that the hardware ENABLE jumper is installed.

Figure 1 - PowerFlex 755 Drives Jumper Locations (frames 1...7)

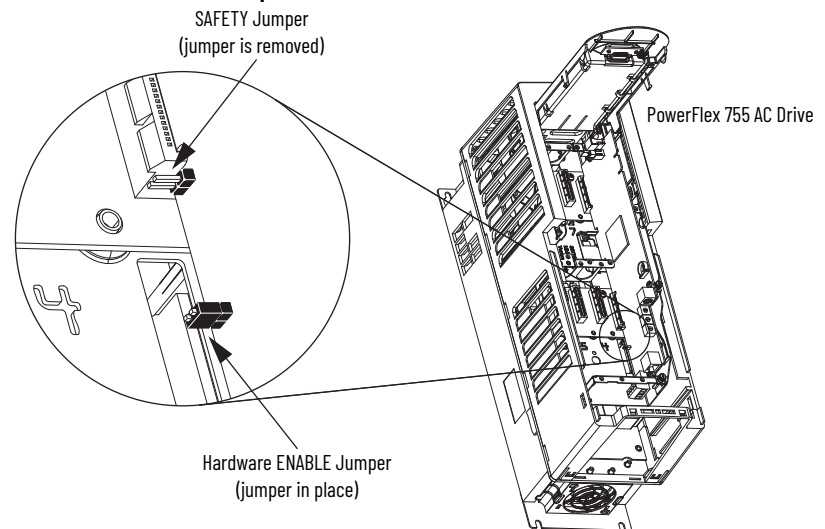

Figure 2 - PowerFlex 755T Drive Products Jumper Locations (all frame sizes)

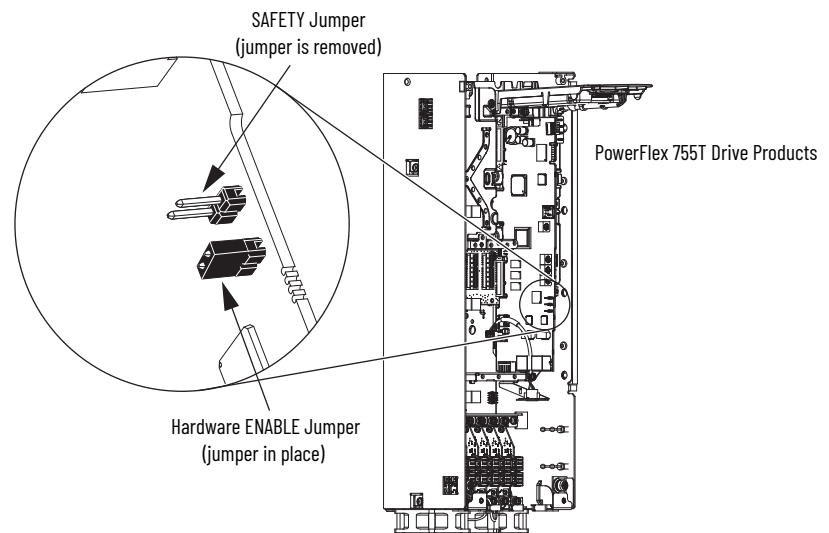
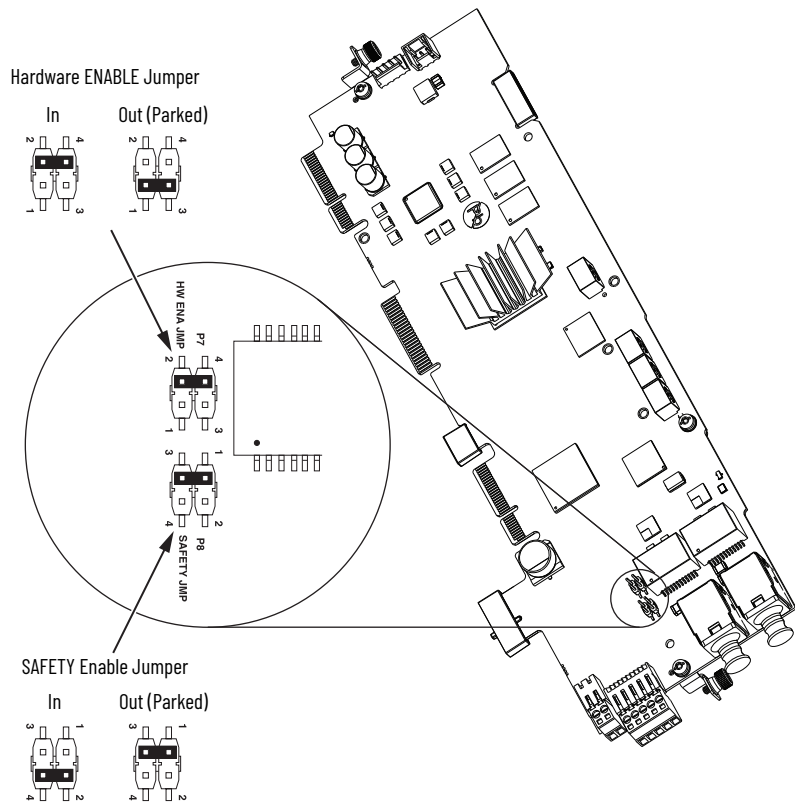

Figure 3 - PowerFlex 755TS Drive Jumper Location



Install the Safety Option Module

To install the Integrated Safety - Safe Torque Off option module in a drive port, follow these steps:

1. Firmly press the module edge connector into the desired port.

IMPORTANT The Integrated Safety - Safe Torque Off option module can be installed in ports 4, 5, or 6.

2. Tighten the top and bottom retaining screws.
 - Recommended torque = 0.45 N•m (4.0 lb•in)
 - Recommended screwdriver = T15 Hexalobular

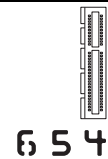

IMPORTANT Do not over-tighten the retaining screws.

IMPORTANT Only one safety option module can be installed at a time. Multiple or duplicate safety option module installations are not supported.

Figure 4 - Tighten Screws

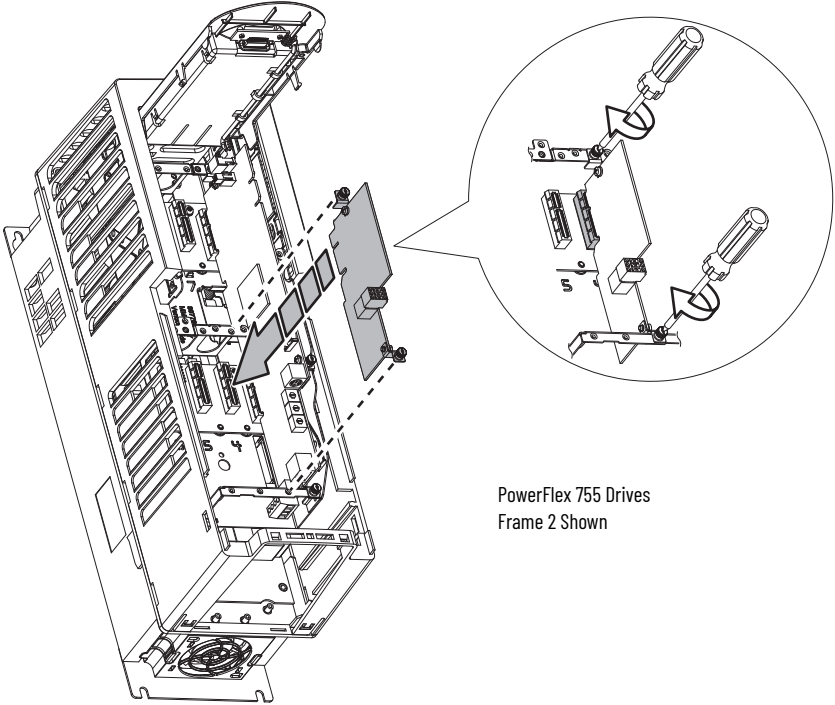

PowerFlex 755 Drives
Frame 2 Shown

Notes:

Configuration

This chapter provides information on how to configure the Integrated Safety - Safe Torque Off option module.

Topic	Page
Description of Operation	25
Out-of-Box State	25

Description of Operation

Safe Torque Off (STO) disables the power transistors so that the probability of torque producing switching is sufficiently low for SIL 3. This STO results in a condition where the motor is coasting (stop category 0). Disabling the power transistor output does not provide mechanical isolation of the electrical output that is required for some applications.

If STO is performed, the Start Inhibits parameter indicates the IGBTs are inhibited, and the HIM indicates that the drive is not enabled. The Start Inhibits parameter is parameter 933 in PowerFlex® 755 drives and parameter 603 in PowerFlex 755T drive products.

You can use the Safe Torque Off circuit in combination with other safety devices to achieve the stop and protection-against-restart as specified in IEC 60204-1.



ATTENTION: If two output IGBTs fail in the drive, when the Integrated Safety - Safe Torque Off option module has controlled the drive outputs to the Off state, the drive can provide stored energy for up to 180° of rotation in a 2-pole motor before torque production in the motor stops.

IMPORTANT

The Integrated Safety - Safe Torque Off option module is suitable for performing mechanical work on the drive train or affected area of a machine only. It does not provide electrical safety.
Do not use this option as a control for starting and/or stopping the drive.

IMPORTANT

The Integrated Safety - Safe Torque Off option module does not remove dangerous voltages at the drive output. Before performing any electrical work on the drive or motor, turn off the input power to the drive, and follow all safety procedures. See [Remove Power from the Drive System on page 20](#) for more information.

Out-of-Box State

When the drive is in the out-of-box state with the SAFETY jumper removed, the STO function is in hardwired mode. See [Chapter 6](#) for hardwired information.

IMPORTANT

Out-of-box state = hardwired mode.
All other states = network mode.

Recognize Out-of-Box State

You can determine if the drive is in the out-of-box state by using a diagnostic parameter or by using the Logix Designer application.

IMPORTANT Only authorized personnel can reset ownership. The safety connection must be inhibited before the reset. If any active connection is detected, the safety reset is rejected.

The safety control state can be read from the Host Config Safety State [P3] parameter via the HIM or Connected Components Workbench™ software. You can also use an MSG command in the Studio 5000 Logix Designer® application to read the Safety Supervisor Status.

If the state is 'Waiting' (8) or 'Wait w Trq' (51), then the safety control is in the out-of-box state.

Restore the Drive to Out-of-Box State

Use the Safety Reset [#14] Diagnostic Item (only online)

Before you can reset the drive to out-of-box state, the value of the Safety Reset [#14] diagnostic item must be 'Ready' (1) or the reset is not allowed. Set the Safety Reset [#14] diagnostic item to 'Reset' (2) by using a HIM or Connected Components Workbench software.

Reset the Drive by Using the Logix Designer Application

After the integrated safety connection configuration is applied to the PowerFlex 755 drive at least once, you can follow these steps to restore your PowerFlex 755 drive to the out-of-box state while online.

1. Right-click the PowerFlex 755 drive you created, and choose Properties.

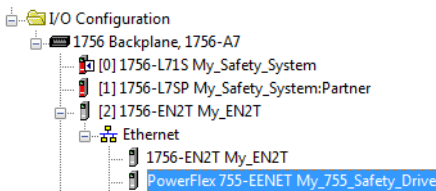

2. Select Connection.

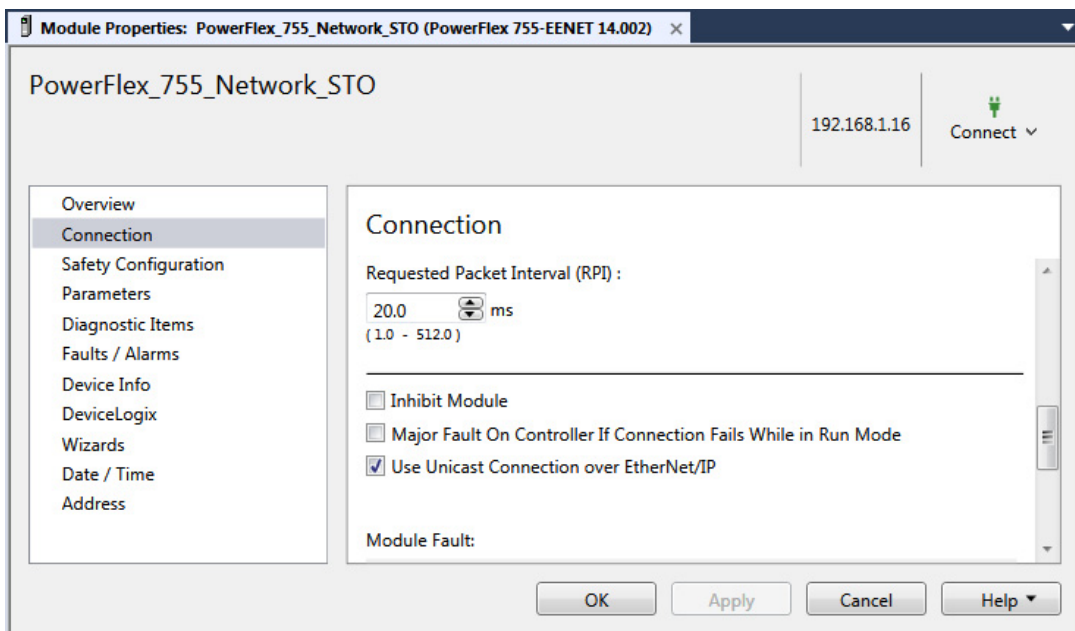

3. Select the Inhibit Module check box.
4. Click Apply.
5. Select Safety Configuration.

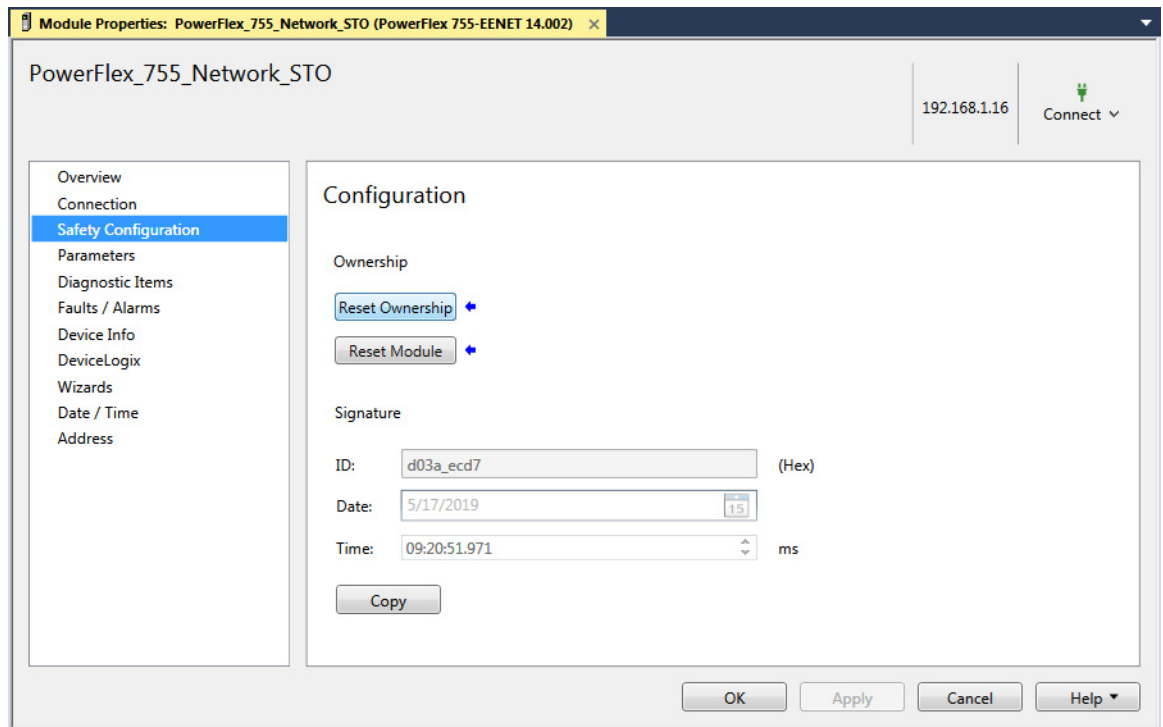

6. Click Reset Ownership.
7. Select Connection.
8. Clear the Inhibit Module check box.
9. Click Apply.
10. Click OK.

Notes:

Standard I/O – Network STO Programming and Operation

This chapter provides information for the programming and operation of the Integrated Safety - Safe Torque Off option module when used in Standard I/O mode.

Topic	Page
Description of Integrated Operation	29
Safe Torque Off Assembly Tags	30
Configure Safe Torque Off in the Logix Designer Application	31
Safe Torque Off – Stop Category 0 Example Program	41
Safe Torque Off – Stop Category 1 Example Program	42
Safe Torque Off Fault Reset	44
Understand Integrated Safety Drive Replacement	45
Replace an Integrated Safety Drive in a GuardLogix System	45

Description of Integrated Operation

The Safe Torque Off (STO) feature provides a method, with sufficiently low probability of failure, to force the power-transistor control signals to a disabled state. When the command to execute the STO function is received from the GuardLogix® controller, all the drive output-power transistors are released from the ON-state. This results in a condition where the drive is coasting. Disabling the power transistor output does not provide mechanical isolation of the electrical output that is required for some applications.

You can use the Safe Torque Off circuit in combination with other safety devices to achieve the stop and protection-against-restart as specified in IEC 60204-1. These conditions must be met for integrated control of the STO function:

- You must have a GuardLogix safety controller project with an EtherNet/IP network connection configured.
- You must add the PowerFlex® drive to the Ethernet network connection in the safety controller I/O tree.

The PowerFlex 755 drives and PowerFlex 755T drive product STO function reaction time is 15 ms maximum. Reaction time is the delay between the time when the drive STO function receives the STO request, and when power that produces the motion is removed from the motor.

Table 5 - Safe Torque Off Network Specifications

Attribute	Value
Safety connection RPI, min	6 ms
Input assembly connections	1
Output assembly connections	1

Safe Torque Off Assembly Tags

In Network mode, the safety controller controls the integrated STO function through the SO.SafeTorqueOff tag in the safety output assembly:

- The SO.Command tags are sent from the controller safety output assembly to the drive safety output assembly to control the Safe Torque Off function.
- The SI.Status tags are sent from the drive to the controller safety input assembly and indicate the safety control status of the drive.
- The SI.ConnectionStatus tags indicate the safety input connection status.

Table 5 on page 29 and Table 6 list the safety tags added to the controller tags when a drive is added to a controller I/O configuration and the connection is configured for safety-only, or standard and safety. The attribute values that are listed are the Assembly Object attribute values.

IMPORTANT Only the data listed in Table 7 are safety data with SIL 3 integrity.

Table 6 - Integrated STO Specifications

Logix Designer Tag Name	Attribute [bit]	Type	Description		
SI.ConnectionStatus ⁽¹⁾⁽²⁾ ₍₃₎		DINT	RunMode Status	Connection Fault Status	Safety Connection Operation
SI.RunMode SI.ConnectionFault	[0] [1]	BOOL BOOL	1 = Run	0 = Valid	Data is being controlled by the producing device. The producing device is in Run mode.
			0 = Idle	0 = Valid	The connection is active and the producing device is in the Idle state. The safety data is reset to zero.
			0 = Idle	1 = Faulted	The safety connection is faulted. The state of the producing device is unknown. The safety data is reset to zero.
			1	1	Invalid state.
SI.Status ⁽¹⁾⁽⁴⁾	0x1A0	DINT			
SI.TorqueDisabled	[0]	BOOL	0 = Torque Permitted 1 = Torque Disabled		
SI.SafetyFault	[6]	BOOL	1 = STO fault present		
SI.ResetRequired	[7]	BOOL	1 = Reset is required		
SO.Command ⁽¹⁾⁽⁵⁾	0x180	DINT			
SO.SafeTorqueOff	[0]	BOOL	0 = Disable Torque 1 = Permit Torque		
SO.Reset	[7]	BOOL	0 --> 1 = Reset STO fault		

(1) Bits not listed are always zero.

(2) The Safety Validator in the safety controller determines the Connection Status.

(3) The first 2 bits of SI.ConnectionStatus contain the SI.RunMode and SI.ConnectionFault status bits of the device. The table describes the combinations of the RunMode and ConnectionFault states.

(4) Status is sent from the drive to the controller by using integrated safety protocol.

(5) Commands are sent from the controller to the drive by using integrated safety protocol.



ATTENTION: Safety I/O connections and produced/consumed connections cannot be automatically configured to fault the controller if a connection is lost and the system transitions to the safe state. Therefore, if you must detect a module fault to be sure that the system maintains SIL 3, you must monitor the SI.ConnectionStatus bits and initiate the fault via program logic.

Configure Safe Torque Off in the Logix Designer Application

This chapter provides instructions for how to add and configure an Integrated Safety - Safe Torque Off option module in a PowerFlex 755 drive or PowerFlex 755T drive product in an existing project in the Logix Designer application. This chapter is specific to safety and does not cover all aspects of drive configuration.

Before you can configure your option module in the Logix Designer application:

- You must have a safety controller project with an EtherNet/IP® network connection configured and Time Sync enabled. See the documentation for your controller, drive, and Ethernet adapter for information on configuring those products (see [Additional Resources on page 9](#)).
- You must add a drive and option card to your project.

To set up your drive with the 20-750-S3 option module, you must configure the following attributes, in addition to the drive's IP address, revision, ratings, and power structure settings:

Port	4, 5, or 6
Electronic Keying	
Exact Match	Indicates that all keying attributes must match to establish communication. If any attribute does not match precisely, communication with the device does not occur.
Compatible Module	Lets the installed device accept the key of the device that is defined in the project when the installed device can emulate the defined device. With Compatible Module, you can typically replace a device with another device that has the following characteristics: <ul style="list-style-type: none"> Same catalog number Same or higher Major Revision Minor Revision as follows: <ul style="list-style-type: none"> If the Major Revision is the same, the Minor Revision must be the same or higher. If the Major Revision is higher, the Minor Revision can be any number.
Disable Keying	Indicates that the keying attributes are not considered when attempting to communicate with a device. With Disable Keying, communication can occur with a device other than the type specified in the project. <div style="text-align: center; border: 1px solid black; padding: 5px;">  <p>ATTENTION: Disable Keying is not permitted for safety devices.</p> </div>

Connection	Description	Requires Controller Firmware Revision
Standard	Control is managed by this controller. Safety is managed by another controller and can be either networked or hardwired.	30.011 or later
Standard and Safety	Both control and network safety connections are managed by this controller. A Standard and Safety connection can only be made from a GuardLogix® controller.	30.012 or later
Safety Only	Network safety connection is managed by this controller. Control is managed by another controller. A Safety connection can only be made from a GuardLogix controller.	30.011 or later

The Enable Automatic Device Configuration and Fail Drive Connection on Peripheral Error check boxes cannot be selected, as ADC is not needed to download configuration to the 20-750-S3 option module. This is handled automatically in the Safety Forward open each time the safety connection gets established with the option module.

Depending on the type of drive that you choose, the configuration options may appear on different dialog boxes in the programming software.

Add a PowerFlex 755/755T Drive Product to the Controller Project

1. Right-click Ethernet network and choose New Module.

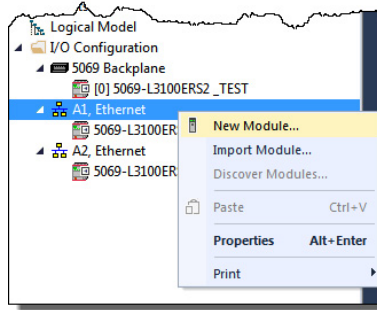

2. Choose one of the following, and then click Create:
 - PowerFlex 755 HiPwr-EENET
 - PowerFlex 755-EENET
 - PowerFlex 755T



If you want to use a 20-750-ENETR Dual-port EtherNet/IP option module with the Integrated Safety - Safe Torque Off option module, you must select PowerFlex 755-EENET or PowerFlex 755 HiPwr-EENET from this list. Later in this procedure, you will use the Synchronize command so that the module reflects an ENETR module and will work with the Integrated Safety - Safe Torque Off module.

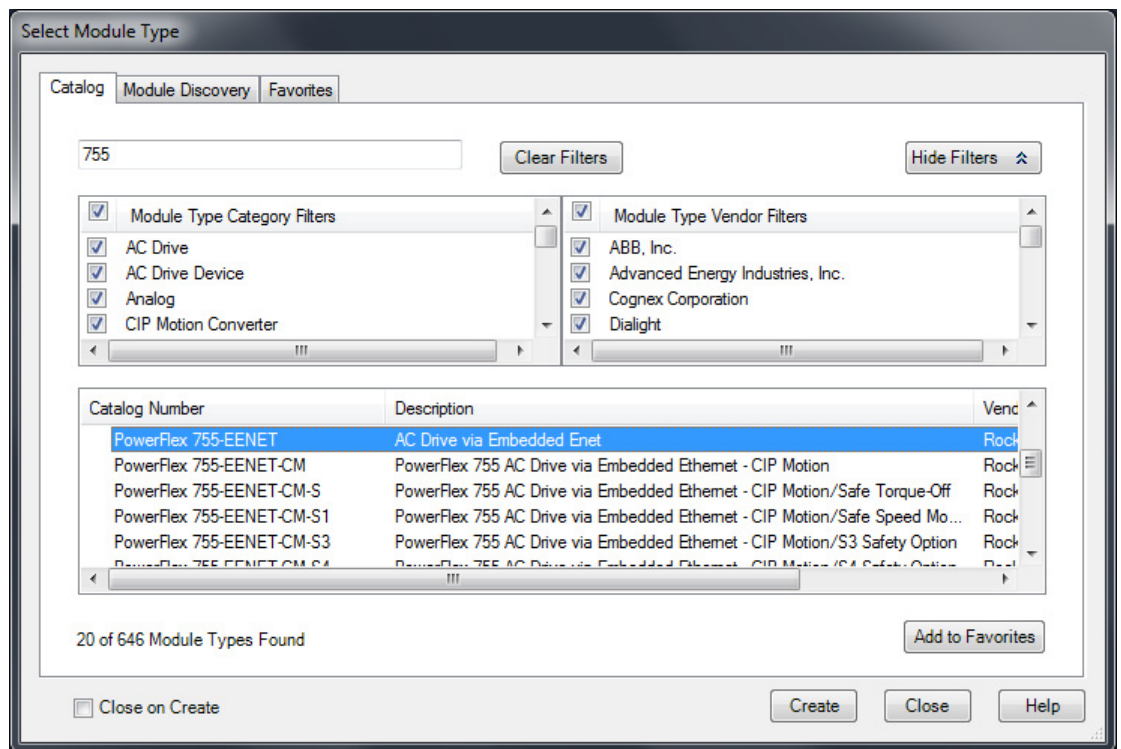

Add an Option Module to a PowerFlex 755/755T Drive Product in I/O Mode

1. In the Device Definition dialog box, under Identity, enter the Connection type that you want to use. Select from one of the following types. The 'Standard and Safety' connection is used in this example.

Connection Type	Description	Requires Controller Firmware Revision
Standard	Control is managed by this controller. Safety is managed by another controller.	V31 or later
Standard and Safety	Both control and network safety connections are managed by this controller. A Standard and Safety connection can only be made from a GuardLogix 5580 or Compact GuardLogix 5380 controller.	V31.012 or later
Safety Only	Network safety connection is managed by this controller. Control is managed by another controller. A Safety connection can only be made from a GuardLogix 5580 or Compact GuardLogix 5380 controller.	V31 or later

The screenshot shows the 'New Module' dialog box with the 'Device Definition' tab selected. The 'Identity' section is active, and the 'Connection' dropdown menu is set to 'Standard and Safety', which is highlighted with a red rectangular box. The 'Type' is 'PowerFlex 755'. Other fields include 'Safety Peripheral' set to '20-750-S3', 'Safety Instance 1' set to 'Stop Torque Only', 'Vendor' set to 'Allen-Bradley', 'Name', 'Parent', and 'Description' fields are empty. The 'Ethernet Address' is set to 'IP Address', 'Safety Network Number' is '4388_0481_E98C', and 'Revision' is '14 - 002'. There are 'OK', 'Cancel', and 'Help' buttons at the bottom.



When the Connection type is 'Standard and Safety' or 'Safety Only', 20-750-S3 appears as the default Safety Peripheral. This is the correct selection for the Integrated Safety - Safe Torque Off option module.

2. Enter additional Device Definition data (such as Name, Description, and Ethernet Address) for the drive product being used.

Generate the Safety Network Number (SNN)

The assignment of a time-based SNN is automatic when you create a GuardLogix safety controller project and add new Safety I/O devices.

Manual manipulation of an SNN is required in the following situations:

- If safety consumed tags are used
- If the project consumes safety input data from a device whose configuration is owned by some other device
- If a safety project is copied to another hardware installation within the same routable Safety system

If an SNN is assigned manually, the SNN has to be unique.

IMPORTANT If you assign an SNN manually, make sure that the system expansion does not result in duplication of SNN and node address combinations.

A warning appears if your project contains duplicate SNN and node address combinations. You can still verify the project, but Rockwell Automation recommends that you resolve the duplicate combinations.

To edit the SNN, follow these steps:

1. In the Device Definition dialog box, click Edit next to the Safety Network Number.

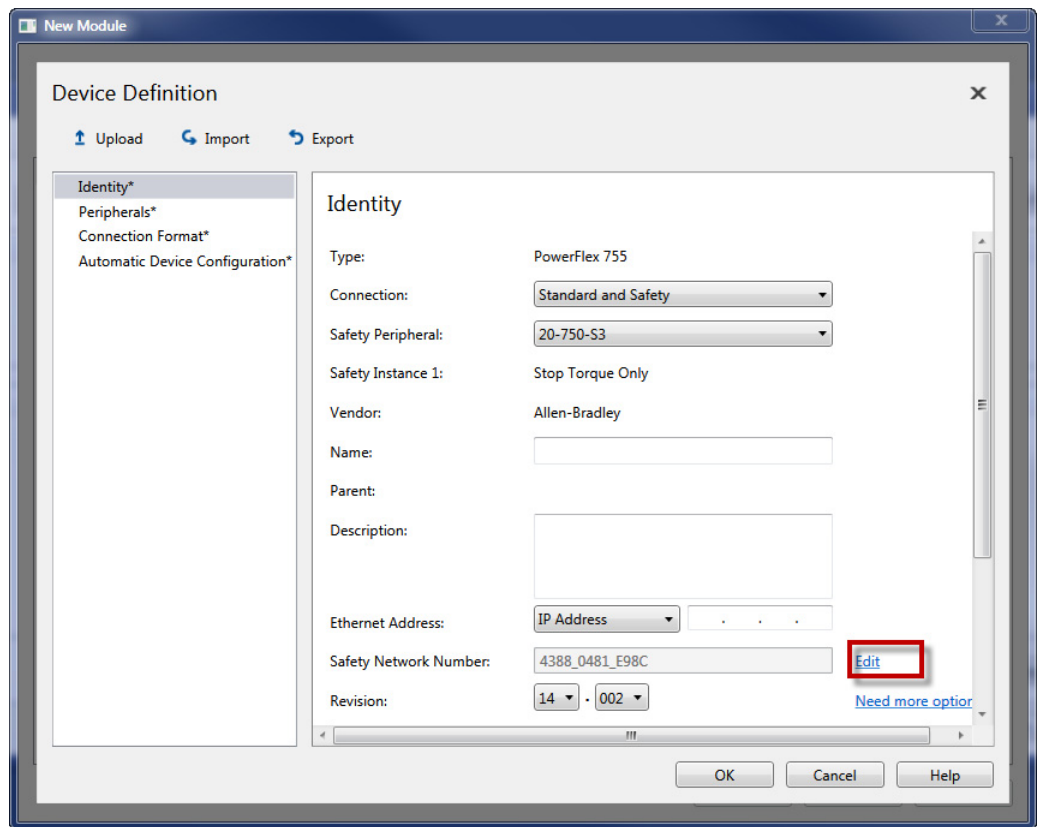

2. Select either Time-based or Manual.
 - If you select Manual, enter a value from 1...9999 decimal.
 - If you select Time-based, click Generate SNN.
 - Click Copy to copy the SNN from the controller, which owns the safety configuration for the drive module.
 - Click Paste to paste the SNN from the configuration owner to the drive module.

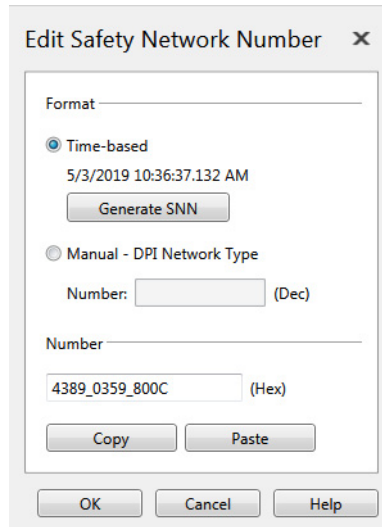

The dialog box is titled "Edit Safety Network Number" and contains the following elements:

- Format:**
 - Time-based: Shows a timestamp "5/3/2019 10:36:37.132 AM" and a "Generate SNN" button.
 - Manual - DPI Network Type: Includes a "Number:" label and an empty text box with "(Dec)" to its right.
- Number:**
 - Shows a text box containing "4389_0359_800C" with "(Hex)" to its right.
 - Buttons for "Copy" and "Paste" are located below the text box.
- Buttons for "OK", "Cancel", and "Help" are at the bottom of the dialog.

3. Click OK on the Edit Safety Network Number dialog box, then click OK on the Device Definition dialog box to add the drive to the project.

Configure Safety Connections

After performing the steps in the preceding sections, additional options are available on the Overview page.

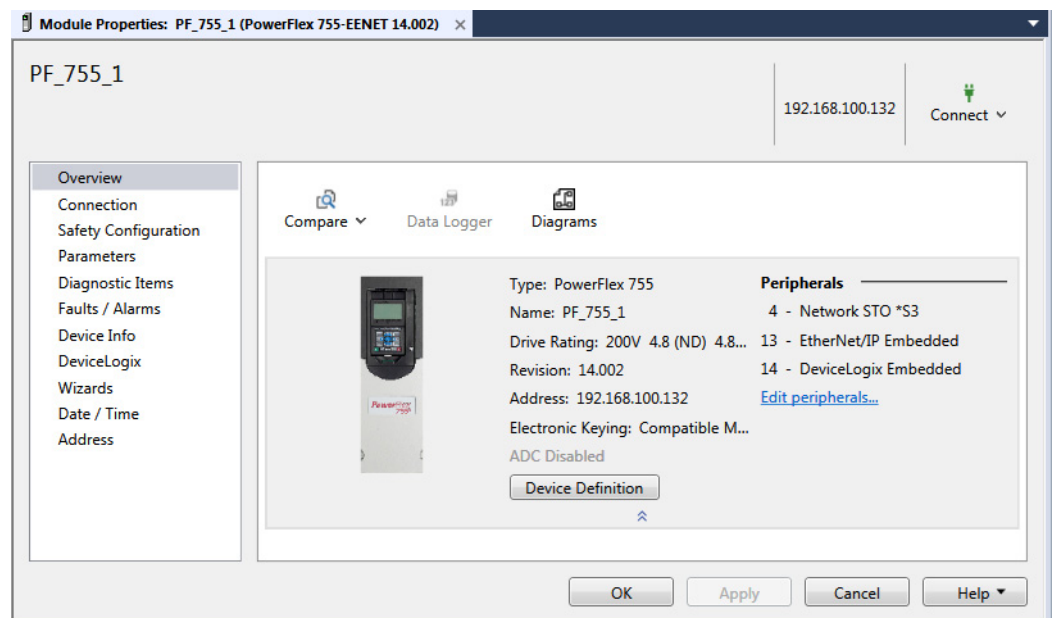

The screenshot shows the "Module Properties" dialog box for a PowerFlex 755 drive module. The title bar reads "Module Properties: PF_755_1 (PowerFlex 755-EENET 14.002)".

The main window displays the following information:

- Module Name:** PF_755_1
- Address:** 192.168.100.132
- Connect:** A green status icon and a "Connect" button with a dropdown arrow.
- Navigation:** Buttons for "Compare", "Data Logger", and "Diagrams".
- Overview Panel (Left):** A list of tabs including Overview, Connection, Safety Configuration, Parameters, Diagnostic Items, Faults / Alarms, Device Info, DeviceLogix, Wizards, Date / Time, and Address.
- Device Information (Center):**
 - Type: PowerFlex 755
 - Name: PF_755_1
 - Drive Rating: 200V 4.8 (ND) 4.8...
 - Revision: 14.002
 - Address: 192.168.100.132
 - Electronic Keying: Compatible M...
 - ADC Disabled
 - Device Definition button
- Peripherals (Right):**
 - 4 - Network STO *S3
 - 13 - EtherNet/IP Embedded
 - 14 - DeviceLogix Embedded
 - [Edit peripherals...](#)

Buttons for "OK", "Apply", "Cancel", and "Help" are located at the bottom of the dialog.

This section describes changes that you can make on the Connection page.

1. Select Connection.
2. Adjust the Safety Input Requested Packet Interval (RPI) as desired for your safety system.

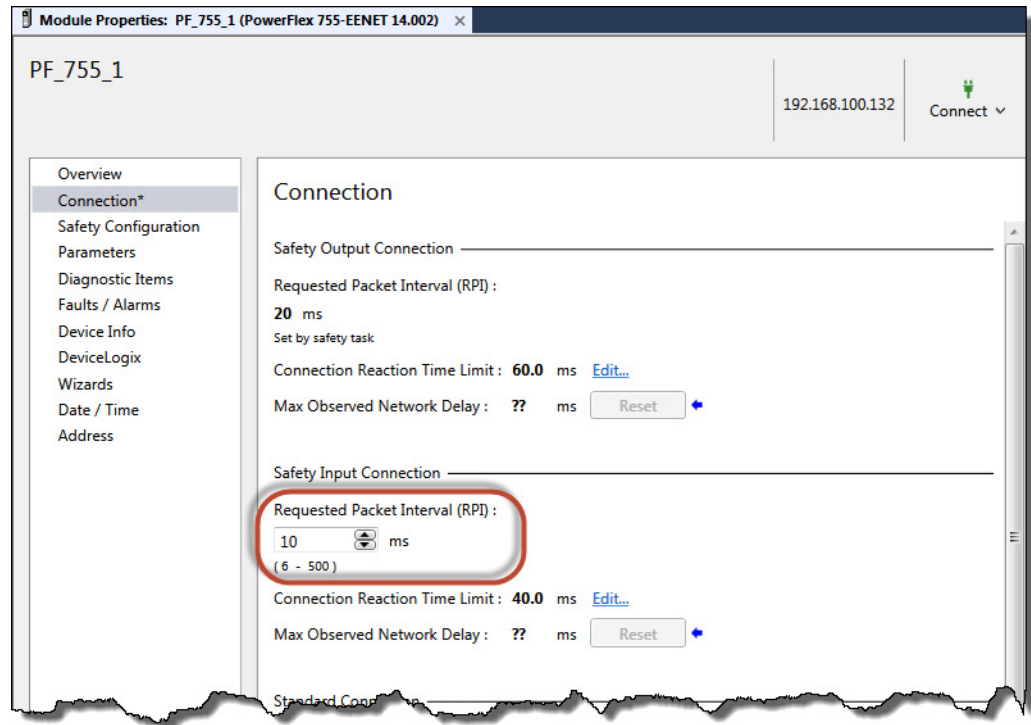

IMPORTANT

If the drive is used with an induction motor, there is a general rule of no repeated (three or more) start/stops with less than 10 seconds between them (assumes the highest RPI of 500 ms is used). Otherwise a safety connection loss can occur. If less than 10 seconds is needed, a lower RPI can be used per the following formula:

$$\text{RPI (ms)} * 19 = \text{Min. Repeated Start/Stop time (seconds)}$$

For example, a 50 ms RPI equates to a minimum of 0.95 seconds required between repeated start/stops.

- Specify additional settings for the Safety Output and Safety Input Connections by clicking Edit next to the Connection Reaction Time Limit.

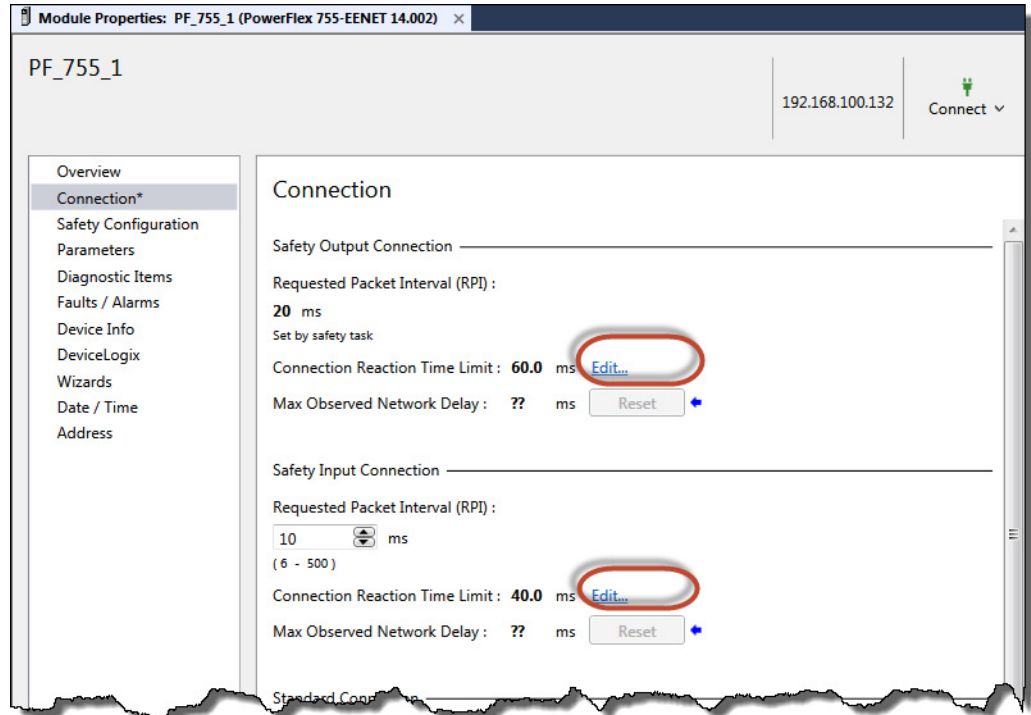

- In the Connection Reaction Time Limit dialog box, specify additional settings as required.

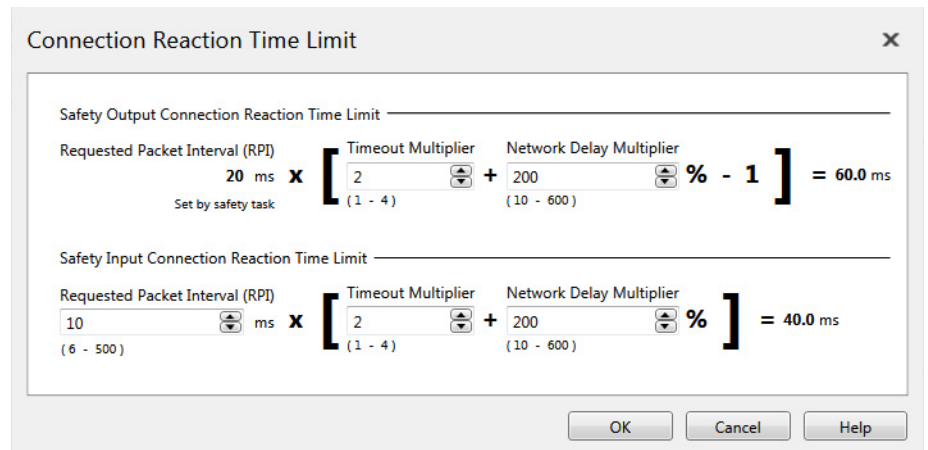

Advanced Reaction Connection Time Limit Configuration Settings	Description
Requested Packet Interval (RPI)	<p>The RPI specifies the period that data updates over a connection. For example, an input module produces data at the RPI that you assign. For safety input connections, you can set the RPI on the Safety tab of the Module Properties dialog box. The RPI is entered in 1 ms increments, with a range of 6...500 ms. The default is 10 ms.</p> <p>The Connection Reaction Time Limit is adjusted immediately when the RPI is changed via the Logix Designer application.</p> <p>For safety output connections, the RPI is fixed at the safety task period. If the corresponding Connection Time Reaction Limit is not satisfactory, you can adjust the safety task period via the Safety Task Properties dialog box of the safety controller. See the user manual for the controller.</p> <p>For typical applications, the default RPI is sufficient. If you are experiencing nuisance connection timeouts, you can either increase the RPI or increase the Time Multiplier.</p>
Timeout Multiplier	<p>The Timeout Multiplier determines the number of RPIs to wait for a packet before declaring a connection timeout. This value translates into the number of messages that can be lost before a connection error is declared. For example, a Timeout Multiplier of 1 indicates that messages must be received during each RPI interval. A Timeout Multiplier of 2 indicates that one message can be lost as long as at least one message is received in two times the RPI (2 x RPI).</p> <p>If you are experiencing nuisance connection timeouts, you can either increase the Time Multiplier or increase the RPI.</p>
Network Delay Multiplier	<p>The Network Delay Multiplier defines the message transport time that the safety protocol enforces. The Network Delay Multiplier specifies the round-trip delay from the producer to the consumer and the acknowledge back to the producer. You can use the Network Delay Multiplier to reduce or increase the Connection Reaction Time Limit in cases where the enforced message transport time is significantly less or more than the RPI. For example, to adjust the Network Delay Multiplier is helpful when the RPI of an output connection is the same as a lengthy safety task period.</p>
Connection Reaction Time Limit	<p>The Connection Reaction Time Limit is the maximum age of safety packets on the associated connection. If the age of the data that is used by the consuming device exceeds the Connection Reaction Time Limit, a connection fault occurs. The following equations determine the Connection Reaction Time Limit:</p> <p>Input Connection Reaction Time Limit = Input RPI x [Timeout Multiplier + Network Delay Multiplier]</p> <p>Output Connection Reaction Time Limit = Safety Task Period x [Timeout Multiplier + Network Delay Multiplier - 1]</p>

5. Click OK to close the Connection Reaction Time Limit dialog box.

Using a 20-750-ENETR Dual-port EtherNet/IP Option Module with a 20-750-S3 Option Module

When using a PowerFlex 755 drive with 20-750-ENETR and 20-750-S3 option modules, the drive must be added to the Controller Organizer as a PowerFlex 755-EENET module instead of a PowerFlex 755-ENETR module. See [page 32](#) for more information.

1. Make sure that the jumper on the 20-750-ENETR option module is in the Tap position.
2. Click Synchronize from the Connect menu. (The Connection to the PowerFlex 755/755T drive product must be 'Standard' or 'Standard and Safety' in order for Synchronize option to be selectable.)

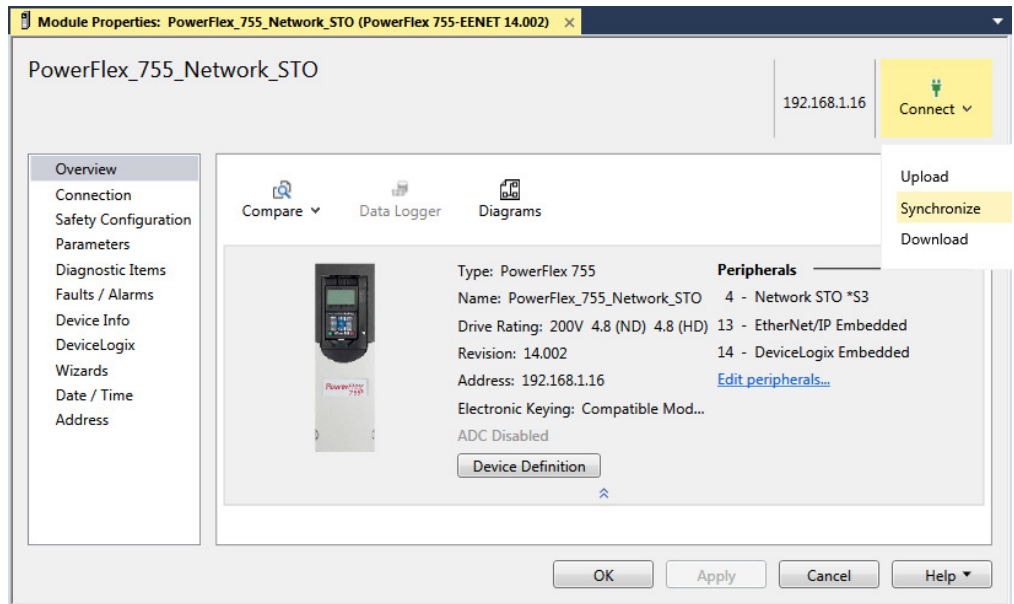

3. If necessary, select your drive in the Synchronize - Identifying Device dialog box, and then click Continue.

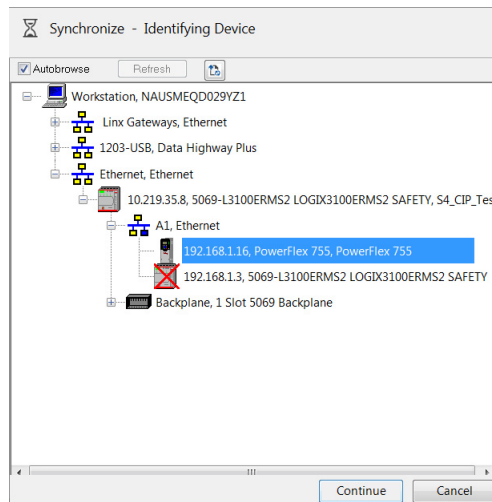

- After selecting Synchronize, select the check box for Use Physical. This matches the project's configuration to the physical configuration of the drive.

If you have already configured parameters offline, you can select the Use Project check box associated with the Parameters Category so that your parameters will not be overwritten during the synchronization. Selecting Use Project sets the parameters in the drive to match the parameter configuration of the offline project.

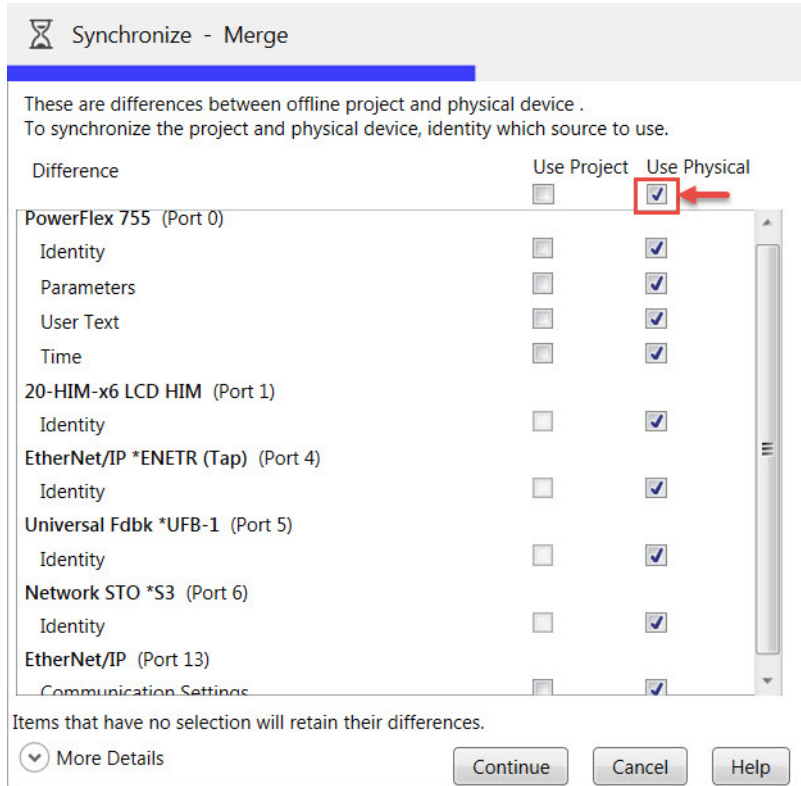

- Click Continue.
- After the synchronization is completed, verify that the 20-750-ENETR option module appears as EtherNet/IP *ENETR (TAP), indicating that the option module is in tap mode.

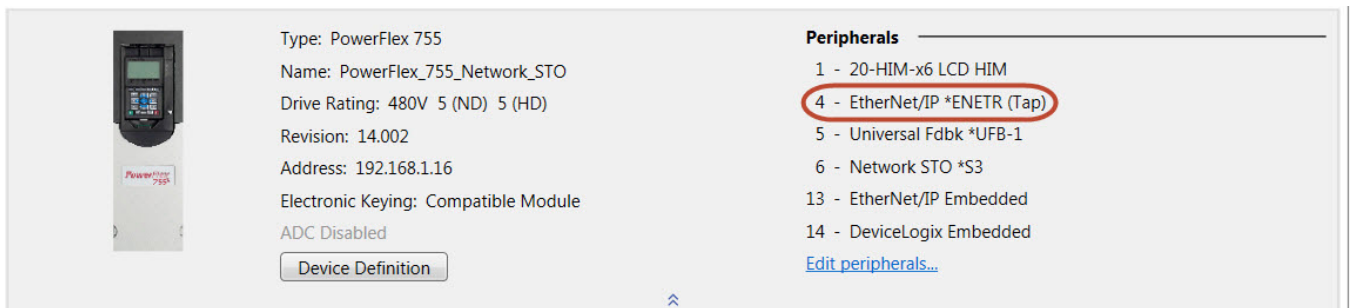

Safety Configuration Signature and Ownership

The connection between the controller and the drive is based on the following criteria:

- Drive catalog number must be for PowerFlex 755 drives, PowerFlex 755TL low harmonic drives, PowerFlex 755TR regenerative drives, or PowerFlex 755TM drive systems
- Drive Safety Network Number (SNN) (displayed on the General tab of the drive's Module Properties dialog box)
- GuardLogix slot number
- GuardLogix safety network number
- Path from the GuardLogix safety controller to the PowerFlex 755 drive or PowerFlex 755T drive product
- Configuration signature (displayed on the Safety tab of the drive's Module Properties dialog box)

If any differences are detected, the safety connection between the safety controller and the drive is not established (new drive/system) or lost (existing drive/system), and a yellow icon appears next to the drive in the controller project tree. Configuration Ownership has to be reset to establish (new) or re-establish (existing) the connection.

Reset Ownership

To reset ownership, see [Restore the Drive to Out-of-Box State on page 26](#).

Safe Torque Off – Stop Category 0 Example Program

This safety task code is an example for a category 0 stop. The STO output is energized if the safety interlocks are satisfied, there are no faults, there is a valid connection, and there is a falling edge on the 'Safety_Reset' button.

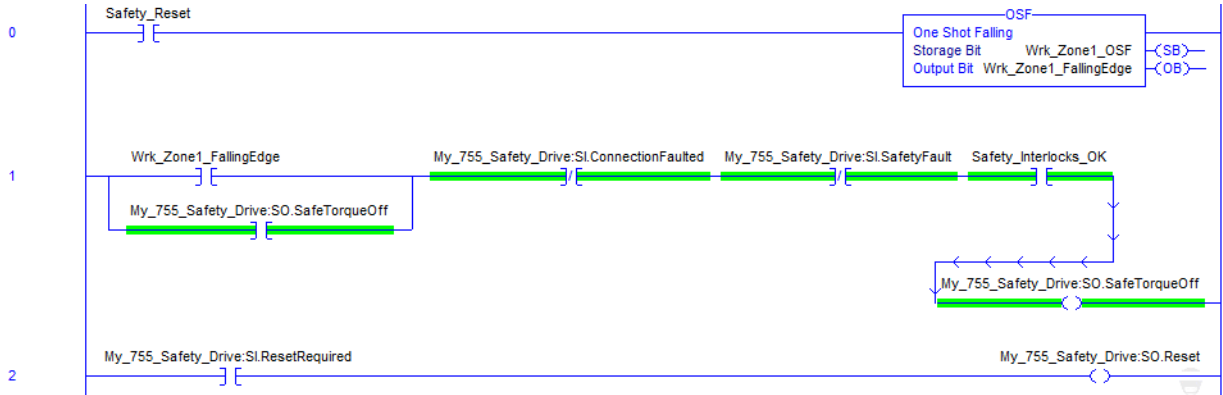

'Safety_Reset' and 'Safety_Interlocks_OK' come from elsewhere in the safety program:

- 'Safety_Reset' is the user-initiated manual reset action that is used in the safety system
- 'Safety_Interlocks_OK' are the safety interlocks that are used with this safety function

The accumulated 'Safety_Interlocks_OK' tag is used in the seal-in rung to drive the STO tag. When a demand is placed on safety interlocks and 'Safety_Interlocks_OK' goes to low (0), then the 20-750-S3 STO output immediately goes to low (0) as well. 'Safe Torque Off' (STO) remains off until a manual reset action is completed after the safety interlocks are satisfied.

Safe Torque Off – Stop Category 1 Example Program

This safety task code is an example for a category 1 stop. The STO output is energized if the safety interlocks are satisfied, there are no faults, there is a valid connection, and there is a falling edge on the 'Safety_Reset' button.

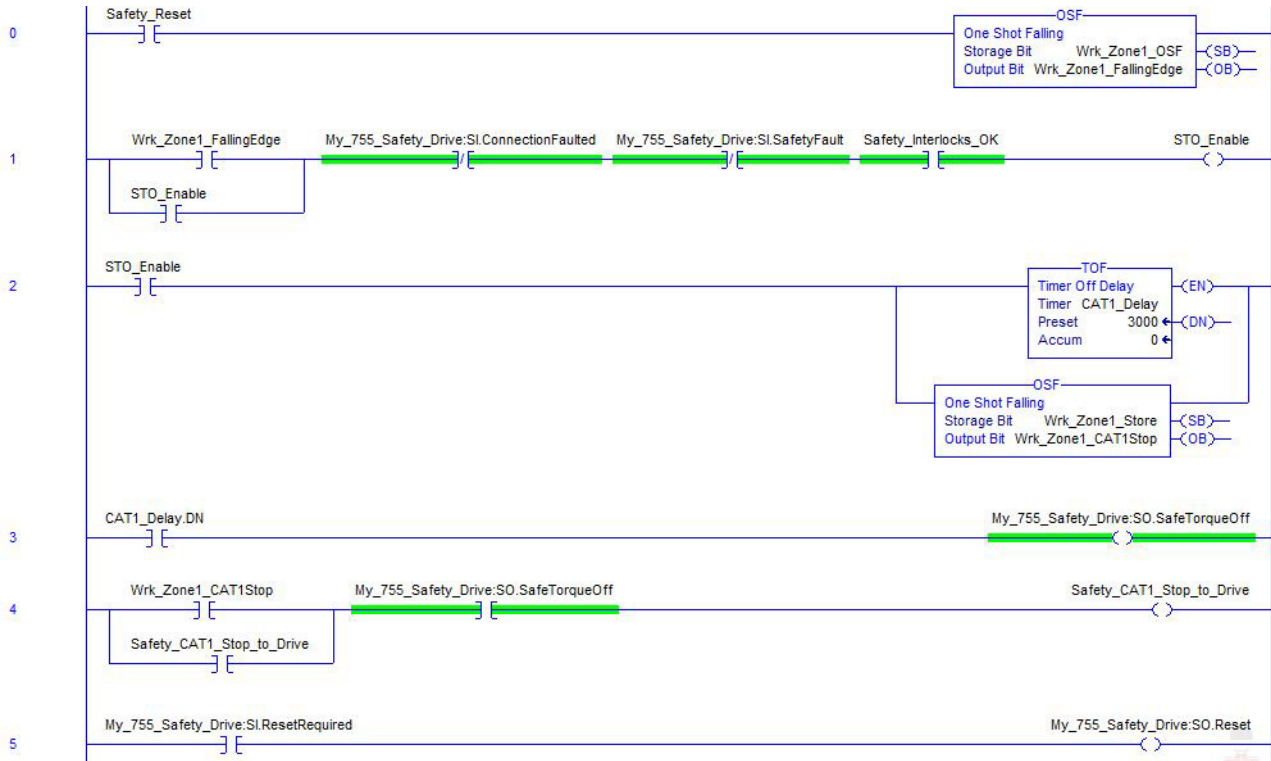

'Safety_Reset' and 'Safety_Interlocks_OK' come from elsewhere in the safety program:

- 'Safety_Reset' is the user-initiated manual reset action that is used in the safety system
- 'Safety_Interlocks_OK' are the safety interlocks that are used with this safety function

The accumulated 'Safety_Interlocks_OK' tag is used in the seal-in rung to drive the STO tag. When a demand is placed on the safety interlocks, then the 20-750-S3 STO output goes to low (0) after a three-second delay. The risk assessment determines the length of the delay. During the three-second delay, the 'Safety_CAT1_Stop_to_Drive' tag can be used in parallel with other main program stop logic to stop the drive in the main program.



'Safe Torque Off' (STO) remains off until a manual reset action is completed after the safety interlocks are satisfied.

Falling Edge Reset

ISO 13849-1 stipulates that instruction reset functions must occur on falling edge signals. To comply with this requirement, a One Shot Falling (OSF) instruction is used on the reset rung. Then, the OSF instruction Output Bit tag is used as the reset bit for the STO output or enable rungs.

Safety Tags in Standard Routines

Tags that are classified as safety tags are either controller-scoped or program-scoped.

- Controller-scoped safety tags are read by either standard or safety logic or other communication devices.
- Controller-scoped safety tags are written only by safety logic or another GuardLogix safety controller.

Program-scoped safety tags are accessible only by local safety routines. These routines reside within the safety program.

Standard Tags in Safety Routines (tag mapping)

Controller-scoped standard tags can be mapped into safety tags, providing a mechanism to synchronize standard and safety actions. In the Logix Designer application, click Logic > Map Safety Tags... to open the Safety Tag Mapping window.

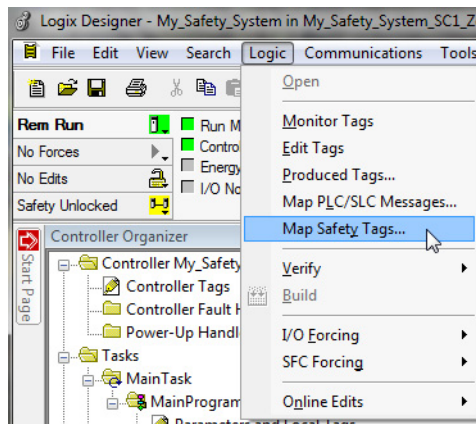

ATTENTION: When using standard data in a safety routine, you are responsible to verify that the data is used in an appropriate manner. The use of standard data in a safety tag does not make it safety data. Do not directly control a safety output with standard tag data.

Safe Torque Off Fault Reset

To clear the STO Fault condition, a transition from logic 0 to 1 of the S0.Reset tag is required.

If the drive safety controller detects a fault, the input assembly tag SI.SafetyFault is set to 1.

IMPORTANT All PowerFlex 755 drives and PowerFlex 755T drive products enter the faulted state if any STO function fault is detected. See [Table 16 on page 74](#) for integrated safety troubleshooting.

See [Figure 5 on page 44](#) for an understanding of the PowerFlex 755 drive and PowerFlex 755T drive products state restart functionality.

Figure 5 - Reset Safe Torque Off Fault Diagram

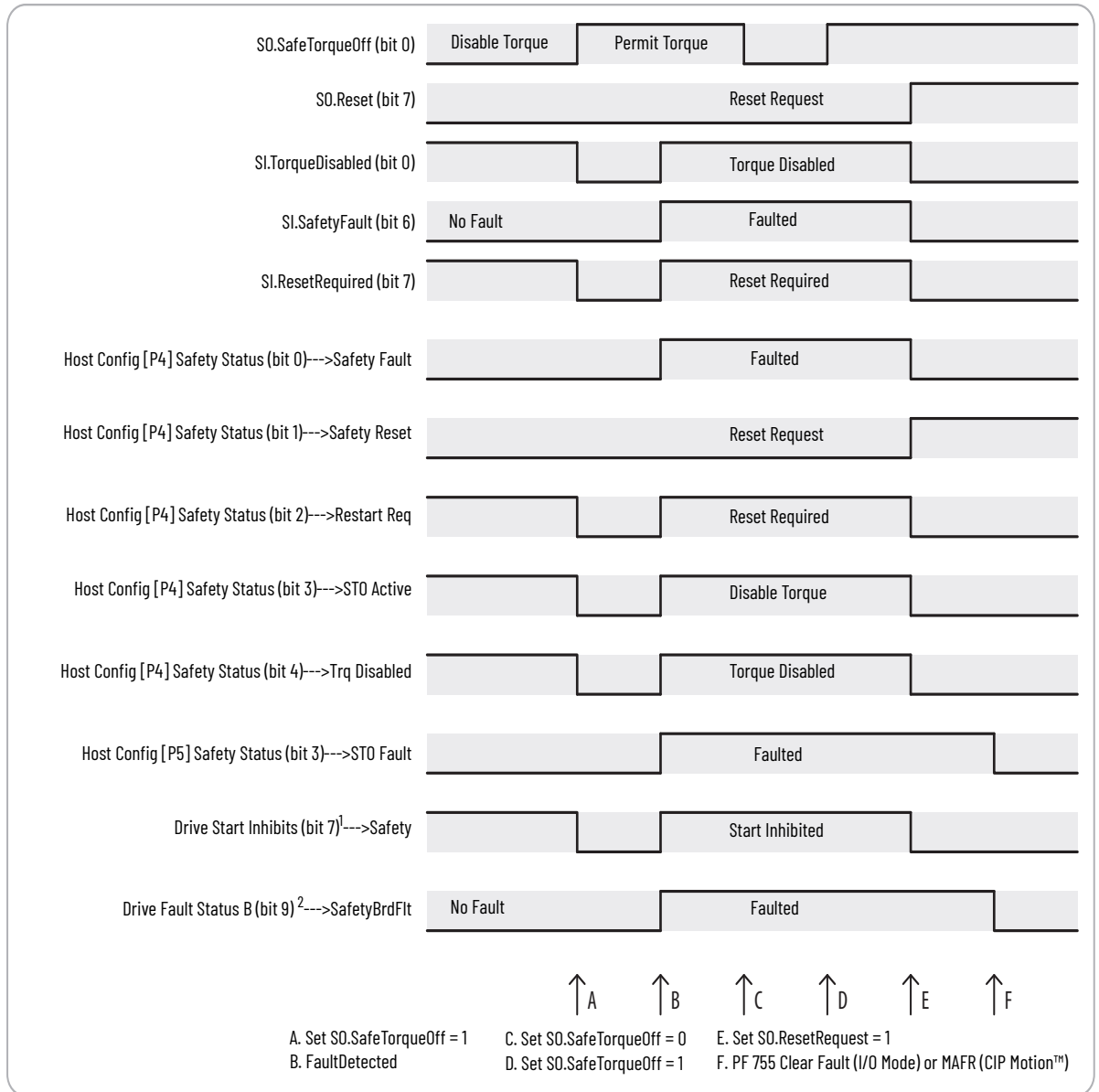

¹ Drive Start Inhibits is parameter 933 in PowerFlex 755 drives and parameter 603 in PowerFlex 755T drive products.

² Drive Fault Status B is parameter 953 in PowerFlex 755 drives and parameter 462 in PowerFlex 755T drive products.

Understand Integrated Safety Drive Replacement

GuardLogix controllers retain I/O device configuration onboard and are able to download the configuration to the replacement device.

IMPORTANT If the replacement card/module was used before, clear the existing configuration before installing the card/module on a safety network by resetting the card/module to Hardwired Safe Torque Off mode. See [Out-of-Box State on page 25](#) for more information.

Replacing an entire PowerFlex 755 drive or PowerFlex 755T drive product on an integrated safety network is more involved than replacing standard devices because of the safety network number (SNN). The device number and SNN is the safety Device ID of the device. Safety devices require this complex identifier to make sure that duplicate device numbers do not compromise communication between the safety devices. The SNN is also used to provide integrity on the initial download to the PowerFlex 755 drive or PowerFlex 755T drive product.

When the Logix Designer application is online, the Safety tab of the Module Properties dialog box displays the current configuration ownership. When the opened project owns the configuration, Local is displayed.

Configuration Ownership: Local

A communication error is displayed if the module read fails. See [Replace an Integrated Safety Drive in a GuardLogix System on page 45](#) for integrated safety drive replacement examples.

Replace an Integrated Safety Drive in a GuardLogix System



ATTENTION: During replacement or functional testing of a device, the safety of the system must not rely on any portion of the affected device.

IMPORTANT The replacement of safety devices requires that the replacement device is properly configured, and that the proper operation of the replacement device is verified.

Two options for I/O device replacement are available on the Safety tab of the Controller Properties dialog box in the Logix Designer application:

- Configure Only When No Safety Signature Exists
- Configure Always

Figure 6 - Safety I/O Replacement Options

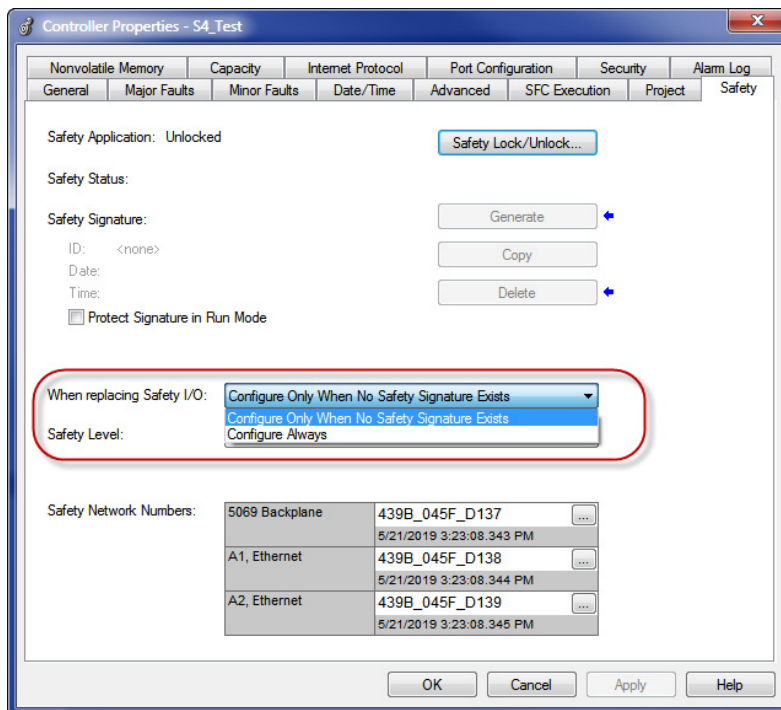

Configure Only When No Safety Signature Exists

This setting instructs the GuardLogix controller to configure a safety device only when the safety task does not have a safety task signature, and the replacement device is in out-of-box condition. Therefore, a safety network number does not exist in the safety device.

If the safety task has a safety task signature, the GuardLogix controller only configures the replacement Safety I/O device if the following is true:

- The device already has the correct safety network number.
- The device electronic keying is correct.
- The node or IP address is correct.

For detailed information on how to replace a safety I/O device, see the user manual for the safety controllers listed in the [Additional Resources on page 9](#).

Configure Always

The GuardLogix controller always attempts to configure a replacement Safety I/O device if the device is in an out-of-box condition, meaning that a safety network number does not exist in the replacement safety device, and the node number and I/O device keying matches the configuration of the controller.



ATTENTION: Enable the Configure Always feature only if the entire safety control system is not being relied on to maintain SIL 3 behavior during the replacement and functional testing of a device. If other parts of the Safety control system are being relied upon to maintain SIL 3, make sure that the 'Configure Always' feature in the controller is disabled.

It is your responsibility to implement a process to make sure that proper safety functionality is maintained during device replacement.



ATTENTION: If you place any devices in the out-of-box condition on any safety network when the Configure Always feature is enabled, follow the device replacement procedure in the respective controller user manual listed in the [Additional Resources on page 9](#).

Integrated Motion – Network STO Programming and Operation

This chapter provides information for network installation and operation of the Integrated Safety - Safe Torque Off option module when used with Integrated Motion.

Topic	Page
Requirements	47
Description of Operation	47
Configure Safe Torque Off in the Logix Designer Application	49
Safe Torque Off – Stop Category 0 Example Program	55
Safe Torque Off – Stop Category 1 Example Program	55

Requirements

The following items are required:

- GuardLogix® 5580 or Compact GuardLogix 5380 controller
- Studio 5000 Logix Designer® application version 31 (or later)
- PowerFlex® 755 v14 firmware (or later)
- PowerFlex Integrated Motion profile version 19.00.00 (or later)
- PowerFlex 755TS v11 firmware (or later)

Integrated Motion support for PowerFlex 755T drive products is planned for a future drive firmware release.

Description of Operation

The Safe Torque Off (STO) feature provides a method, with sufficiently low probability of failure, to force the power-transistor control signals to a disabled state. When the command to execute the STO function is received from the GuardLogix controller, all the drive output-power transistors are released from the ON-state. This results in a condition where the drive is coasting. Disabling the power transistor output does not provide mechanical isolation of the electrical output that is required for some applications.

You can use the Safe Torque Off circuit in combination with other safety devices to achieve the stop and protection-against-restart as specified in IEC 60204-1. These conditions must be met for integrated control of the STO function:

- You must have a GuardLogix safety controller project with an EtherNet/IP® network connection configured.
- You must add the PowerFlex drive to the Ethernet network connection in the safety controller I/O tree.

The PowerFlex 755 drive STO function response time is less than 15 ms. Response time for the drive is the delay between the time the drive STO command receives the CIP Safety™ packet with an STO request and the time when motion producing power is removed from the motor.

Table 7 - Safe Torque Off Network Specifications

Attribute	Value
Safety connection RPI, min	6 ms
Input assembly connections ⁽¹⁾	1
Output assembly connections ⁽¹⁾	1

(1) Motion and Safety and Safety-only connections with the inverter uses 1 input assembly connection and 1 output assembly connection.

Safe Torque Off Assembly Tags

In Integrated Safe Torque Off (STO) mode, a GuardLogix 5580 or Compact GuardLogix 5380 safety controller controls the PowerFlex 755 Safe Torque Off function through the SO.SafeTorqueOff tag in the safety output assembly.

The SO.Command tags are sent from the GuardLogix safety output assembly to the PowerFlex 755 safety output assembly to control the Safe Torque Off function.

The SI.Status tags are sent from the PowerFlex 755 to the GuardLogix safety input assembly and indicate the PowerFlex 755 safety control status.

The SI.ConnectionStatus tags indicate the safety input connection status.

Table 9 lists the safety tags added to the controller tags when a PowerFlex 755 drive is added to a GuardLogix I/O configuration and the connection is configured for Motion and Safety or Safety-only.

The attribute values listed are the Assembly Object attribute values.

Table 8 - Integrated STO Specifications

Logix Designer Tag Name	Attribute [bit]	Type	Description
SI.ConnectionStatus ⁽¹⁾⁽²⁾		DINT	The ConnectionStatus data type contains RunMode and ConnectionFault status bits.
SI.RunMode	[0]	BOOL	See Table 9 on page 49 for descriptions of the combinations of the RunMode and ConnectionFault states.
SI.ConnectionFault	[1]	BOOL	
SI.Status ⁽¹⁾⁽³⁾	0x1A0	SINT	
SI.TorqueDisabled	[0]	BOOL	0 = Torque Permitted 1 = Torque Disabled
SI.SafetyFault	[6]	BOOL	1 = STO fault present
SI.ResetRequired	[7]	BOOL	1 = Reset is required
SO.Command ⁽¹⁾⁽⁴⁾	0x180	SINT	
SO.SafeTorqueOff	[0]	BOOL	0 = Disable Permit 1 = Permit Torque
SO.Reset	[7]	BOOL	0 --> 1 = Reset STO fault

- (1) Bits not listed are always zero.
- (2) ConnectionStatus is determined by the Safety Validator in the GuardLogix controller.
- (3) Status is sent from the drive to the controller using integrated safety protocol.
- (4) Commands are sent from the controller to the drive using integrated safety protocol.

IMPORTANT Only the data listed in [Table 8](#) is safety data with SIL 3 integrity.

Table 9 – Safety Connection Status

RunMode Status	ConnectionFaulted Status	Safety Connection Operation
1 = Run	0 = Valid	Data is actively being controlled by the producing device. The producing device is in Run mode.
0 = Idle	0 = Valid	The connection is active and the producing device is in the Idle state. The safety data is reset to zero.
0 = Idle	1 = Faulted	The safety connection is faulted. The state of the producing device is unknown. The safety data is reset to zero.
1	1	Invalid state.

Configure Safe Torque Off in the Logix Designer Application

This chapter provides instructions for how to add and configure an Integrated Safety - Safe Torque Off option module in a PowerFlex 755 drive in an existing project in the Logix Designer application. This chapter is specific to safety and does not cover all aspects of drive configuration.

Before you can configure your option module in the Logix Designer application:

- You must have a safety controller project with an EtherNet/IP network connection configured and Time Sync enabled. See the documentation for your controller, drive, and Ethernet adapter for information on configuring those products (see [Additional Resources on page 9](#)).
- You must add a drive and option card to your project.

To set up your drive with the 20-750-S3 option card, you must configure the following attributes, in addition to the drive's IP address, revision, ratings, and power structure settings:

Port	Integrated Motion: Port 6 only
-------------	--------------------------------

Electronic Keying

Exact Match	Indicates that all keying attributes must match to establish communication. If any attribute does not match precisely, communication with the device does not occur.
Compatible Module	<p>Lets the installed device accept the key of the device that is defined in the project when the installed device can emulate the defined device. With Compatible Module, you can typically replace a device with another device that has the following characteristics:</p> <ul style="list-style-type: none"> Same catalog number Same or higher Major Revision Minor Revision as follows: <ul style="list-style-type: none"> If the Major Revision is the same, the Minor Revision must be the same or higher. If the Major Revision is higher, the Minor Revision can be any number.
Disable Keying	<p>Indicates that the keying attributes are not considered when attempting to communicate with a device. With Disable Keying, communication can occur with a device other than the type specified in the project.</p> <div style="border: 1px solid black; padding: 5px; display: flex; align-items: center;">  <p>ATTENTION: Disable Keying is not permitted for safety devices.</p> </div>

Connection	Description	Requires Controller Firmware Revision
Motion	Integrated Motion on an EtherNet/IP network is managed by this controller. Safety is managed by another controller and can be either networked or hardwired.	31.000 ⁽¹⁾ or later for ControlLogix 5570 and GuardLogix 5580 31.000 ⁽¹⁾ or later for Compact Logix 5370 and Compact GuardLogix 5380
Motion and Safety	Integrated Motion on an EtherNet/IP network and integrated STO are managed by this controller. A Motion and Safety connection can only be made from a GuardLogix controller.	31.000 or later for GuardLogix 5580 and Compact GuardLogix 5380
Safety Only	Network safety connection is managed by this controller. Control is managed by another controller. A Safety connection can only be made from a GuardLogix controller.	

(1) Firmware revision 30.001 can be used if the drive is used in Standard I/O Mode.

Add a PowerFlex 755 Drive to the Controller Project

1. Right-click EtherNet network and choose New Module.

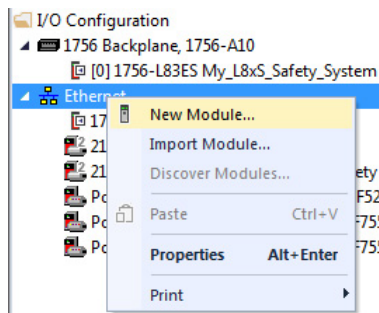

2. Select a PowerFlex 755 drive for Integrated Motion on EtherNet/IP networks (selection catalog number ends in -CM-S3 for drives with network STO option).

Catalog Number	Description	Vendor	Category
PowerFlex 755 HiPwr PMM-EENET	High Power AC Drive, Permanent Magnet Motor, Deep Well	Rockwell Autom...	Drive
PowerFlex 755 HiPwr-EENET	AC Drive via Embedded Enet (Frame 8 and higher)	Rockwell Autom...	Drive
PowerFlex 755 HiPwr-ENETR	AC Drive via ENETR (Frame 8 and higher)	Rockwell Autom...	Drive
PowerFlex 755 HiPwr-NET-E	AC Drive via 20-COMM-E (Frame 8 and higher)	Rockwell Autom...	Drive
PowerFlex 755 PMM-EENET	AC Drive, Permanent Magnet Motor, Deep Well	Rockwell Autom...	Drive
PowerFlex 755-EENET	AC Drive via Embedded Enet	Rockwell Autom...	Drive
PowerFlex 755-EENET-CM	PowerFlex 755 AC Drive via Embedded Ethernet - CIP Motion	Rockwell Autom...	Drive, Motion
PowerFlex 755-EENET-CM-S	PowerFlex 755 AC Drive via Embedded Ethernet - CIP Motion/Safe Torque-Off	Rockwell Autom...	Drive, Motion
PowerFlex 755-EENET-CM-S1	PowerFlex 755 AC Drive via Embedded Ethernet - CIP Motion/Safe Speed Monitor	Rockwell Autom...	Safety, Drive, Mot...
PowerFlex 755-EENET-CM-S3	PowerFlex 755 AC Drive via Embedded Ethernet - CIP Motion/S3 Safety Option	Rockwell Autom...	Safety, Drive, Mot...
PowerFlex 755-EENET-CM-S4	PowerFlex 755 AC Drive via Embedded Ethernet - CIP Motion/S4 Safety Option	Rockwell Autom...	Safety, Drive, Mot...
PowerFlex 755-ENETR	AC Drive via ENETR	Rockwell Autom...	Drive
PowerFlex 755-HiPwr-EENET-CM	PowerFlex 755 High Power AC Drive via Embedded Ethernet - CIP Motion	Rockwell Autom...	Drive, Motion
PowerFlex 755-HiPwr-EENET-CM-S	PowerFlex 755 High Power AC Drive via Embedded Ethernet - CIP Motion/Safe T...	Rockwell Autom...	Drive, Motion
PowerFlex 755-HiPwr-EENET-CM-S1	PowerFlex 755 High Power AC Drive via Embedded Ethernet - CIP Motion/Safe S...	Rockwell Autom...	Safety, Drive, Mot...
PowerFlex 755-HiPwr-EENET-CM-S3	PowerFlex 755 High Power AC Drive via Embedded Ethernet - CIP Motion/S3 Saf...	Rockwell Autom...	Safety, Drive, Mot...
PowerFlex 755-HiPwr-EENET-CM-S4	PowerFlex 755 High Power AC Drive via Embedded Ethernet - CIP Motion/S4 Saf...	Rockwell Autom...	Safety, Drive, Mot...
PowerFlex 755-NET-E	AC Drive via 20-COMM-E	Rockwell Autom...	Drive

3. Configure an Option Card on a PowerFlex 755 Drive in Integrated Motion on EtherNet/IP Network Applications as described in the following section.

Configure an Option Card on a PowerFlex 755 Drive in Integrated Motion on EtherNet/IP Network Applications

1. On the New Module dialog box, name the drive.
2. Type the IP Address.

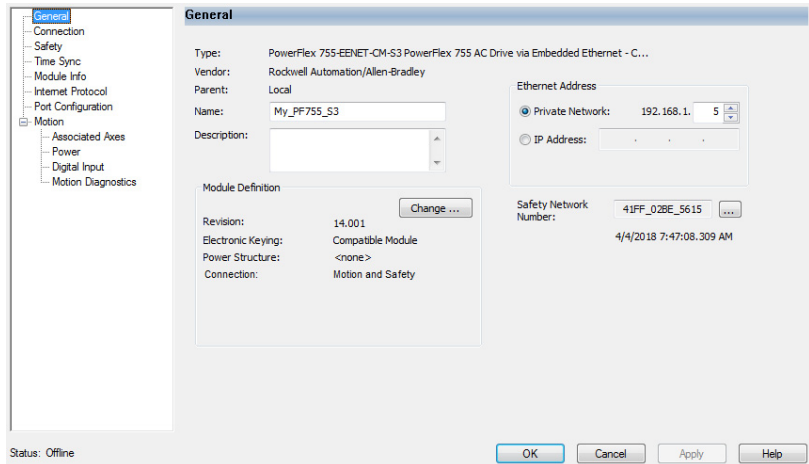

3. Click Change to edit the Module Definition.

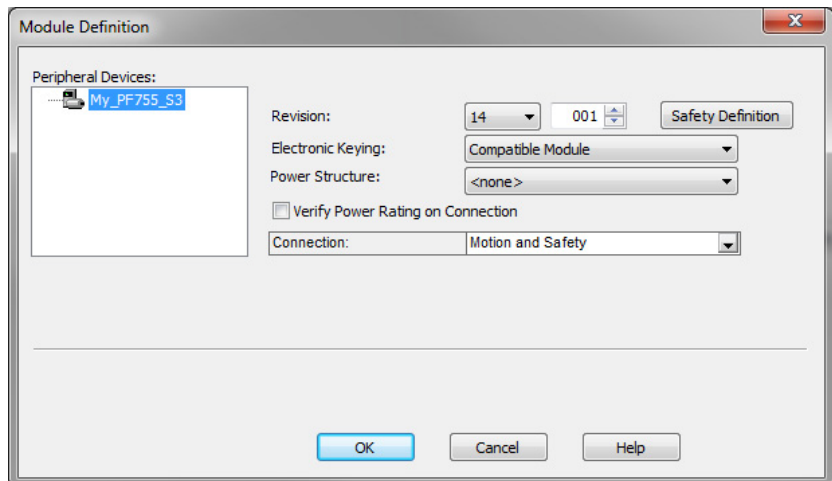

4. On the Module Definition dialog box, configure the drive's properties:
 - a. Revision
 - b. Electronic Keying
 - c. Power Structure
 - d. Connection Type
5. If desired, select the Verify Power Rating on Connection check box to verify the power rating on connection.
6. Click Safety Definition to configure 20-750-S3 revision and Electronic Keying.

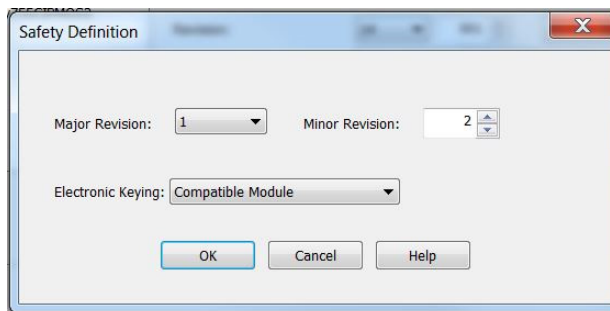

7. Click OK to close the Safety Definition dialog box.

8. Click OK to close the Module Definition dialog box.
Note that the Safety Network Number (SNN) is on the General page and that there is a Safety page.
9. Continue with Generate the SNN as described in the following section.

Generate the Safety Network Number (SNN)

The assignment of a time-based SNN is automatic when you create a GuardLogix safety controller project and add new Safety I/O devices.

Manual manipulation of an SNN is required in the following situations:

- If safety consumed tags are used
- If the project consumes safety input data from a device whose configuration is owned by some other device
- If a safety project is copied to another hardware installation within the same routable Safety system

If an SNN is assigned manually, the SNN has to be unique.

IMPORTANT If you assign an SNN manually, make sure that the system expansion does not result in duplication of SNN and node address combinations. A warning appears if your project contains duplicate SNN and node address combinations. You can still verify the project, but Rockwell Automation recommends that you resolve the duplicate combinations.

To edit the SNN, follow these steps.

1. To open the Safety Network Number dialog box, click  to the right of the Safety Network Number.
2. Select either Time-based or Manual.
If you select Manual, enter a value from 1...9999 decimal.
3. Click Generate.
4. Click OK.

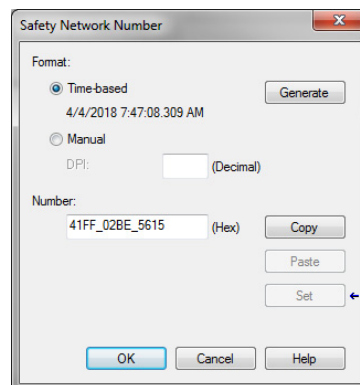

Configure Safety Connections

To configure the safety tab, follow these steps.

1. Click the Safety tab in the drive Module Properties.
2. Adjust the Safety Input Requested Packet Interval (RPI) as desired for your safety system.

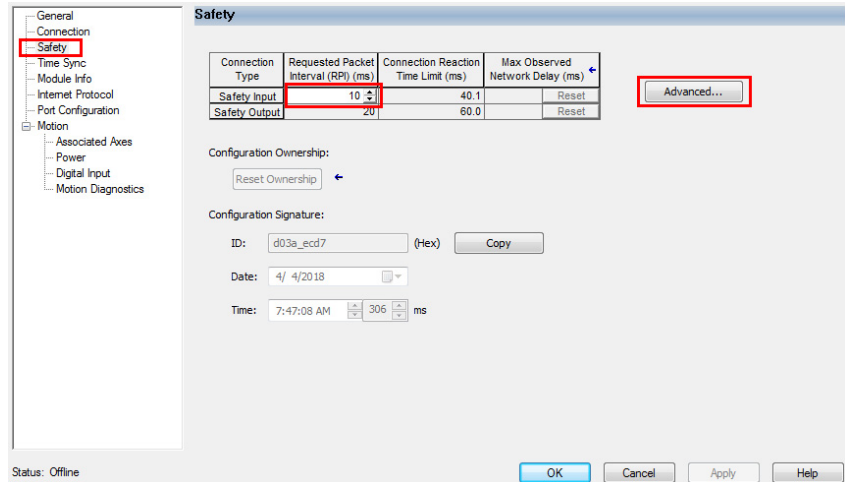

IMPORTANT

If the drive is used with an induction motor, there is a general rule of no repeated (three or more) start/stops with less than 10 seconds between them (assumes the highest RPI of 500 ms is used). Otherwise a safety connection loss can occur. If less than 10 seconds is needed, a lower RPI can be used per the following formula:

$$\text{RPI (ms)} * 19 = \text{Min. Repeated Start/Stop time (seconds)}$$

For example, a 50 ms RPI equates to a minimum of 0.95 seconds required between repeated start/stops.

3. Click Advanced... for more advanced settings.
4. Configure the advanced settings as desired.

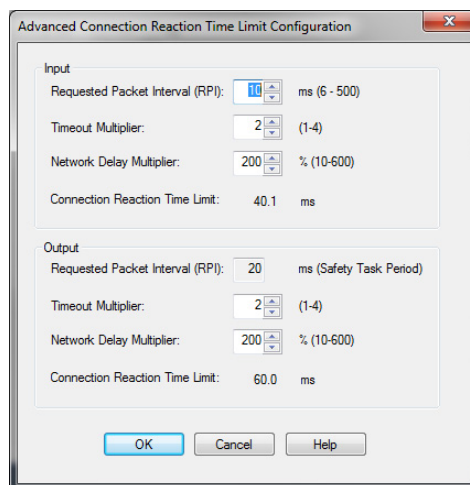

Advanced Reaction Connection Time Limit Configuration Settings	Description
Requested Packet Interval (RPI)	<p>The RPI specifies the period that data updates over a connection. For example, an input module produces data at the RPI that you assign. For safety input connections, you can set the RPI on the Safety tab of the Module Properties dialog box. The RPI is entered in 1 ms increments, with a range of 6...500 ms. The default is 10 ms.</p> <p>The Connection Reaction Time Limit is adjusted immediately when the RPI is changed via the Logix Designer application.</p> <p>For safety output connections, the RPI is fixed at the safety task period. If the corresponding Connection Time Reaction Limit is not satisfactory, you can adjust the safety task period via the Safety Task Properties dialog box of the safety controller. See the user manual for the controller.</p> <p>For typical applications, the default RPI is sufficient.</p>
Timeout Multiplier	<p>The Timeout Multiplier determines the number of RPIs to wait for a packet before declaring a connection timeout. This value translates into the number of messages that can be lost before a connection error is declared. For example, a Timeout Multiplier of 1 indicates that messages must be received during each RPI interval. A Timeout Multiplier of 2 indicates that one message can be lost as long as at least one message is received in two times the RPI (2 x RPI).</p>
Network Delay Multiplier	<p>The Network Delay Multiplier defines the message transport time that the safety protocol enforces. The Network Delay Multiplier specifies the round-trip delay from the producer to the consumer and the acknowledge back to the producer. You can use the Network Delay Multiplier to reduce or increase the Connection Reaction Time Limit in cases where the enforced message transport time is significantly less or more than the RPI. For example, to adjust the Network Delay Multiplier is helpful when the RPI of an output connection is the same as a lengthy safety task period.</p>
Connection Reaction Time Limit	<p>The Connection Reaction Time Limit is the maximum age of safety packets on the associated connection. If the age of the data that is used by the consuming device exceeds the Connection Reaction Time Limit, a connection fault occurs. The following equations determine the Connection Reaction Time Limit:</p> <p>Input Connection Reaction Time Limit = Input RPI x [Timeout Multiplier + Network Delay Multiplier]</p> <p>Output Connection Reaction Time Limit = Safety Task Period x [Timeout Multiplier + Network Delay Multiplier - 1]</p>

5. Click OK.

Safety Configuration Signature and Ownership

The connection between the controller and the drive is based on the following criteria:

- Drive catalog number must be for PowerFlex 755 drives
- Drive Safety Network Number (SNN) (displayed in the drive’s Module Properties dialog box.)
- GuardLogix slot number
- GuardLogix safety network number
- Path from the GuardLogix 5580 safety controller or Compact GuardLogix 5380 safety controller to the PowerFlex 755 drive
- Configuration signature (displayed on the Safety tab of the drive Module Properties dialog box)

If any differences are detected, the safety connection between the safety controller and the drive is not established (new drive/system) or lost (existing drive/system), and a yellow icon appears next to the drive in the controller project tree. Configuration Ownership has to be reset to establish (new) or re-establish (existing) the connection.

Reset Ownership

To reset ownership, see [Restore the Drive to Out-of-Box State on page 26](#).

Safe Torque Off – Stop Category 0 Example Program

This safety task code is an example for a category 0 stop. The STO output is energized if the safety interlocks are satisfied, there are no faults, there is a valid connection, and there is a falling edge on the 'Safety_Reset' button.

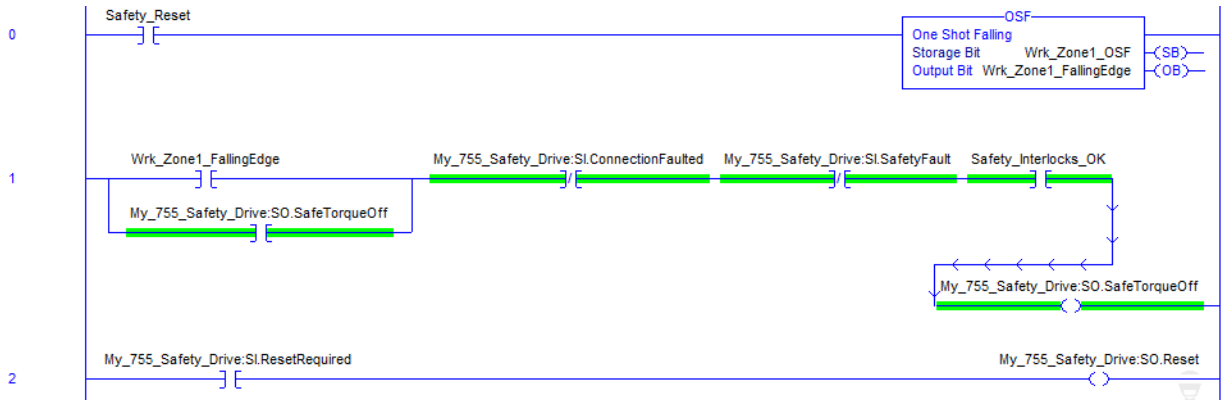

'Safety_Reset' and 'Safety_Interlocks_OK' come from elsewhere in the safety program:

- 'Safety_Reset' is the user-initiated manual reset action that is used in the safety system
- 'Safety_Interlocks_OK' are the safety interlocks that are used with this safety function

The accumulated 'Safety_Interlocks_OK' tag is used in the seal-in rung to drive the STO tag. When a demand is placed on safety interlocks and 'Safety_Interlocks_OK' goes to low (0), then the 20-750-S3 STO output immediately goes to low (0) as well. 'Safe Torque Off' (STO) remains off until a manual reset action is completed after the safety interlocks are satisfied.

Safe Torque Off – Stop Category 1 Example Program

This safety task code is an example for a category 1 stop. The STO output is energized if the safety interlocks are satisfied, there are no faults, there is a valid connection, and there is a falling edge on the 'Safety_Reset' button.

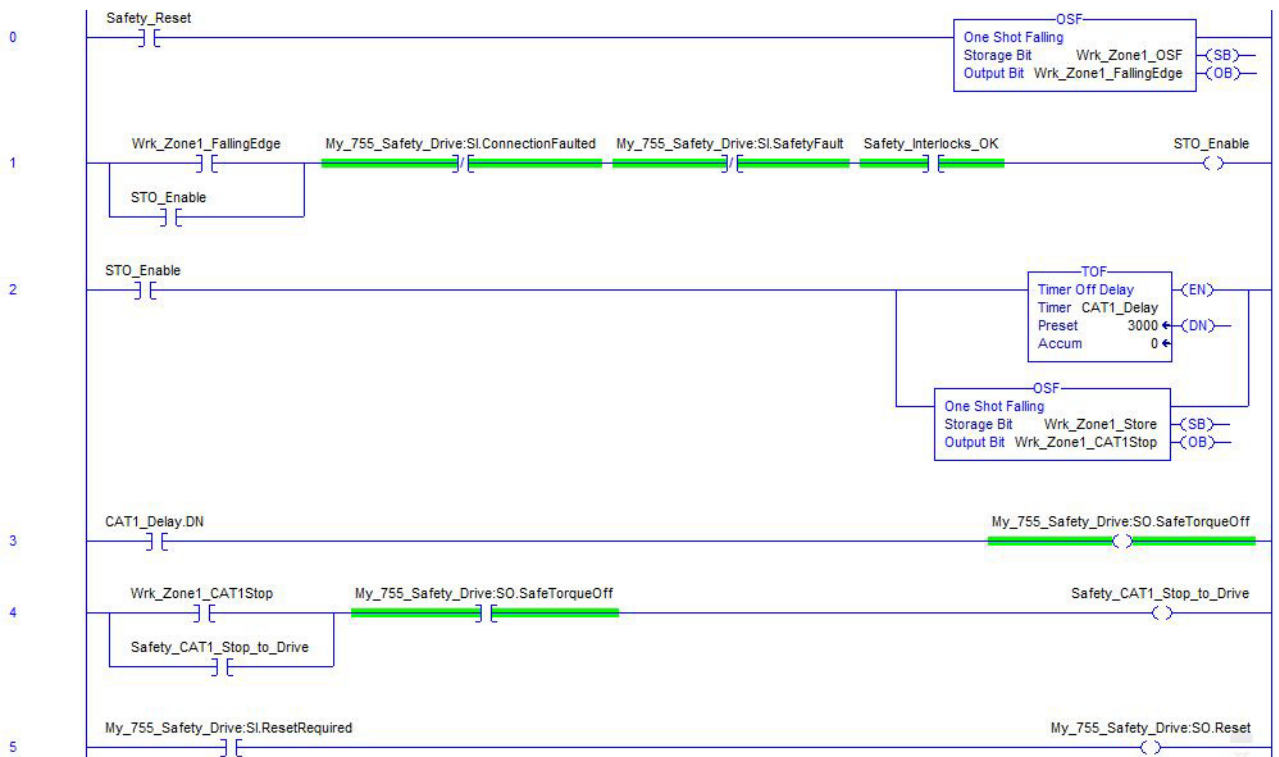

'Safety_Reset' and 'Safety_Interlocks_OK' come from elsewhere in the safety program:

- 'Safety_Reset' is the user-initiated manual reset action that is used in the safety system
- 'Safety_Interlocks_OK' are the safety interlocks that are used with this safety function

The accumulated 'Safety_Interlocks_OK' tag is used in the seal-in rung to drive the STO tag. When a demand is placed on the safety interlocks, then the 20-750-S3 STO output goes to low (0) after a three-second delay. The risk assessment determines the length of the delay. During the three-second delay, the 'Safety_CAT1_Stop_to_Drive' tag can be used in parallel with other main program stop logic to stop the drive in the main program.

'Safe Torque Off' (STO) remains off until a manual reset action is completed after the safety interlocks are satisfied.

Falling Edge Reset

ISO 13849-1 stipulates that instruction reset functions must occur on falling edge signals. To comply with this requirement, a One Shot Falling (OSF) instruction is used on the reset rung. Then, the OSF instruction Output Bit tag is used as the reset bit for the STO output or enable rungs.

Safety Tags in Standard Routines

Tags that are classified as safety tags are either controller-scoped or program-scoped.

- Controller-scoped safety tags are read by either standard or safety logic or other communication devices.
- Controller-scoped safety tags are written only by safety logic or another GuardLogix safety controller.

Program-scoped safety tags are accessible only by local safety routines. These routines reside within the safety program.

Standard Tags in Safety Routines (tag mapping)

Controller-scoped standard tags can be mapped into safety tags, providing a mechanism to synchronize standard and safety actions. In the Logix Designer application, click Logic > Map Safety Tags... to open the Safety Tag Mapping window.

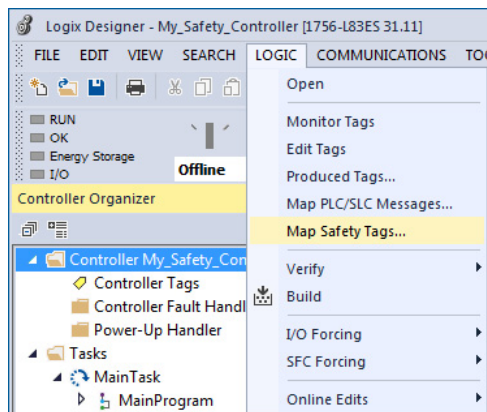

ATTENTION: When using standard data in a safety routine, you are responsible to verify that the data is used in an appropriate manner. The use of standard data in a safety tag does not make it safety data. Do not directly control a safety output with standard tag data.

STO Fault Reset

To clear the STO Fault condition, a transition from logic 0 to 1 of the S0.Reset tag is required.

If the PowerFlex 755 drive safety controller detects a fault, the input assembly tag SI.SafetyFault is set to 1.

To reset an Axis.SafetyFault, a Motion Axis Fault Reset (MAFR) command must be issued.

IMPORTANT The PowerFlex drive will enter the faulted state if a STO function fault is detected. See [Table 10 on page 58](#) for integrated safety troubleshooting.

See [Figure 7 on page 57](#) for an understanding of the PowerFlex 755 STO state restart functionality.

Figure 7 - Reset Safe Torque Off Fault Diagram

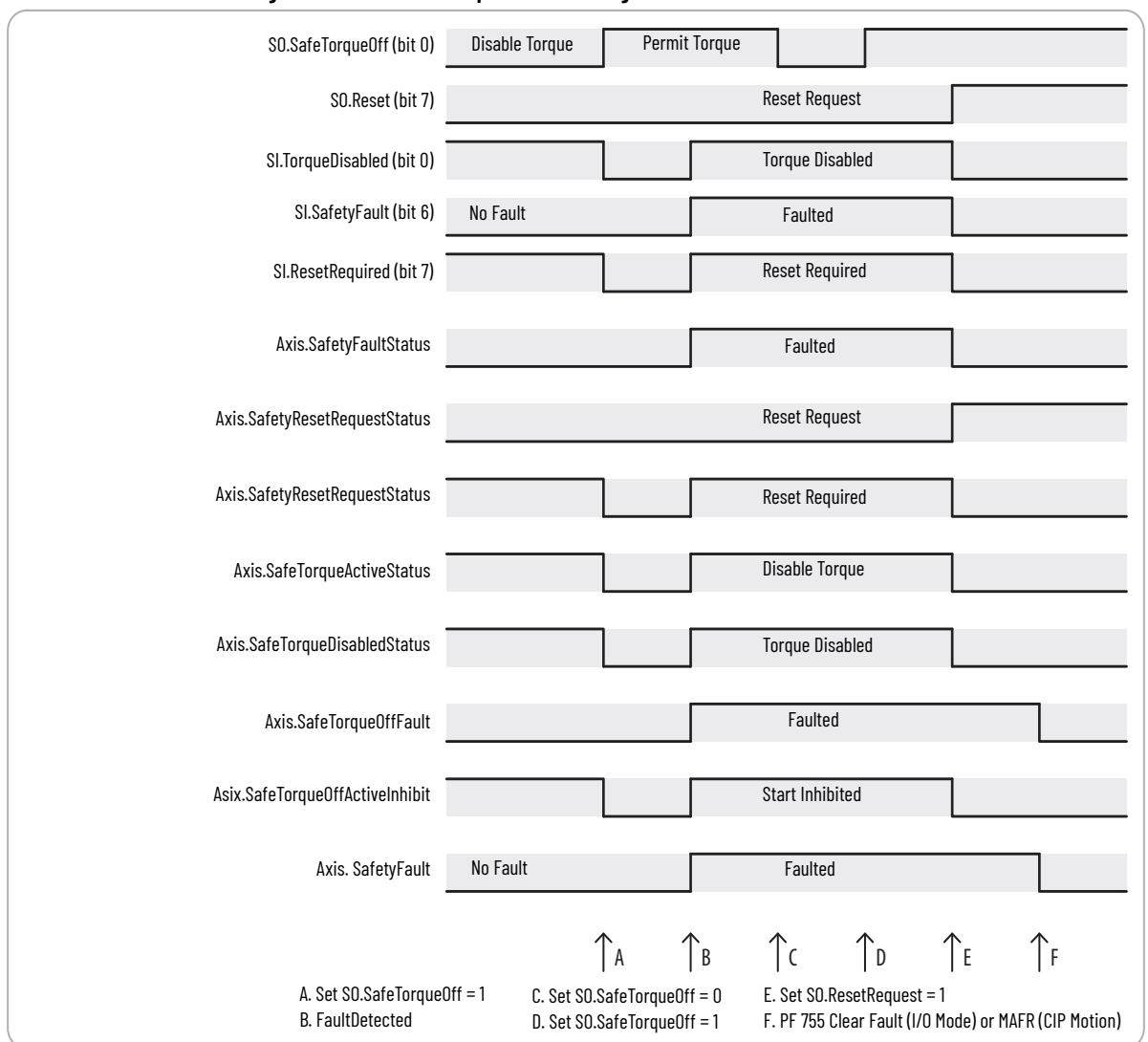

Troubleshoot the Safe Torque Off Function

Table 10 - PowerFlex 755 Integrated STO

Fault Message Logix Designer	Problem	Possible Solutions
SafetyFault	Drive safety diagnostic detected internal STO design failure.	<ul style="list-style-type: none"> • Cycle drive control power • Return drive and/or option module for repair if fault continues
SafeTorqueOffFault ⁽¹⁾	Drive safety diagnostic detected internal STO design failure or hardwired input received while in integrated safety mode.	<ul style="list-style-type: none"> • Check the cause of the fault using an MSG instruction. See Safe Torque Off Faults on page 77. • Remove any connection to the hardwired safety inputs and reset using the STO Fault Reset procedure. See STO Fault Reset on page 57. • Execute STO function. • Return drive and/or option module for repair if fault continues.
InvalidSafetyFirmwareFault ⁽²⁾	Invalid safety firmware.	<ul style="list-style-type: none"> • Cycle control power. • Upgrade the drive firmware. • Call Technical Support. • Return drive for repair if fault continues.

(1) Displayed in the Quick View Pane as Safety Fault.
 (2) Displayed in the Quick View Pane as Initialization Fault.

Understand Integrated Safety Drive Replacement

GuardLogix controllers retain I/O device configuration onboard and are able to download the configuration to the replacement device.

IMPORTANT If the replacement option module was used previously, clear the existing configuration before installing it on a safety network. See [Out-of-Box State](#) on [page 25](#).

Replacing a PowerFlex 755 drive that is on an integrated safety network is more complicated than replacing standard devices because of the safety network number (SNN). The device number and SNN make up the safety device’s DeviceID. Safety devices require this more complex identifier to make sure that duplicate device numbers do not compromise communication between the correct safety devices. The SNN is also used to provide integrity on the initial download to the drive.

When the Logix Designer application is online, the Safety tab of the Module Properties dialog box displays the current configuration ownership. When the opened project owns the configuration, Local is displayed.



A communication error is displayed if the module read fails. See [Replace an Integrated Safety Drive in a GuardLogix System](#) on [page 58](#) for integrated safety drive replacement information.

Replace an Integrated Safety Drive in a GuardLogix System

When you replace an integrated safety drive, the replacement device must be configured properly and the replacement drives operation be user-verified.



ATTENTION: During drive replacement or functional test, the safety of the system must not rely on any portion of the affected drive.

Two options for safety drive replacement are available on the Safety tab of the Controller Properties dialog box in the Logix Designer application:

- Configure Only When No Safety Signature Exists
- Configure Always

Figure 8 - Safety Drive Replacement Options

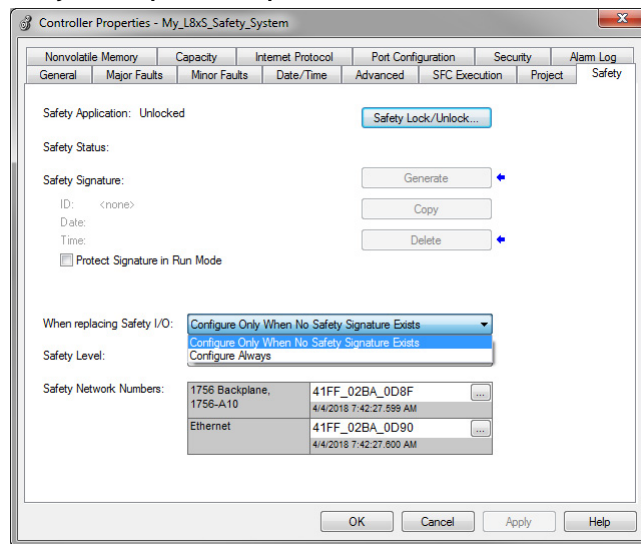

Configure Only When No Safety Signature Exists

This setting instructs the GuardLogix controller to automatically configure a safety drive only when the safety task does not have a safety task signature, and the replacement drive is in an out-of-box condition, meaning that a safety network number does not exist in the safety drive.

If the safety task has a safety task signature, the GuardLogix controller automatically configures the replacement CIP Safety I/O device only if the following is true:

- The device already has the correct safety network number.
- The device electronic keying is correct.
- The node or IP address is correct.

For details, see information about replacing a safety I/O device in the GuardLogix 5580 Controllers User Manual, publication [1756-UM543](#) or Compact GuardLogix 5380 Controllers User Manual, publication [5069-UM001](#).

Configure Always

When the Configure Always feature is enabled, the controller automatically checks for and connects to a replacement drive that meets all of the following requirements:

- The controller has configuration data for a compatible drive at that network address
- The drive is in Hardwired STO mode or has an SNN that matches the configuration



ATTENTION: Enable the Configure Always feature only if the entire integrated safety control system is not being relied on to maintain SIL 3 behavior during the replacement and functional testing of a PowerFlex 755 drive.

If other parts of the integrated safety control system are being relied upon to maintain SIL 3, make sure that the controller's Configure Always feature is disabled.

It is your responsibility to implement a process to make sure proper safety functionality is maintained during device replacement.



ATTENTION: Do not place any devices in the out-of-box condition on any integrated safety network when the Configure Always feature is enabled, except while following the device replacement procedure in the GuardLogix user manual appropriate for your Logix5000 controller:

- GuardLogix 5580 Controllers User Manual, publication [1756-UM543](#)
- Compact GuardLogix 5580 Controllers User Manual, publication [5069-UM001](#)

Motion Direct Commands in Motion Control Systems

You can use the Motion Direct Command (MDC) feature to initiate motion while the controller is in Program mode, independent of application code that is executed in Run mode. These commands let you perform various functions, for example, move an axis, jog an axis, or home an axis.

A typical use might involve a machine integrator testing different parts of the motion system while the machine is being commissioned or a maintenance engineer, under certain restricted scenarios in accordance with safe machine operating procedures, wanting to move an axis (like a conveyor) to clear a jam before resuming normal operation.



ATTENTION: To avoid personal injury or damage to equipment, follow these rules regarding Run mode and Program mode.

- Only authorized, trained personnel with knowledge of safe machine operation should be allowed to use Motion Direct Commands
- Additional supervisory methods, like removing the controller key switch, should be used to maintain the safety integrity of the system after returning the safety controller to RUN mode

Understand STO Bypass When Using Motion Direct Commands

If a Safety-only connection between the GuardLogix safety controller and the PowerFlex 755 drive was established at least once after the drive was received from the factory, the drive does not allow motion while the safety controller is in Program mode by default.

This is because the safety task is not executed while the GuardLogix safety controller is in Program mode. This applies to applications running in a single-safety controller (with Motion and Safety connections). When an integrated safety drive has a Motion connection to a standard controller and a separate Safety connection to a dual-safety controller, the standard controller can transition to Program mode while the safety controller stays in Run mode and continues to execute the safety task.

However, PowerFlex 755 drive systems are designed with a bypass feature for the STO function in single-safety controller configurations. You can use the MDC feature to allow motion while following all the necessary and prescribed steps per your machine's safety operating procedures.



ATTENTION: Consider the consequences of allowing motion through the use of MDC when the controller is in Program mode. You must acknowledge warning messages in the Logix Designer application that warn of the drive bypassing the STO function and unintended motion can occur. The integrated safety drive does not respond to requests of the STO function if MDC mode is entered.

It is your responsibility to maintain machine safety integrity while executing motion direct commands. One alternative is to provide ladder logic for Machine Maintenance mode that leaves the controller in Run mode with safety functions executing.

Logix Designer Application Warning Messages

When the controller is in Run mode, executing safety functions, the PowerFlex 755 drive follows the commands that it receives from the safety controller. The controller reports Safety State = Running and Axis State = Stopped/Running, as shown in [Figure 9 on page 61](#).

Figure 9 - Safety State Indications When Controller is in Run Mode (safety task executing)

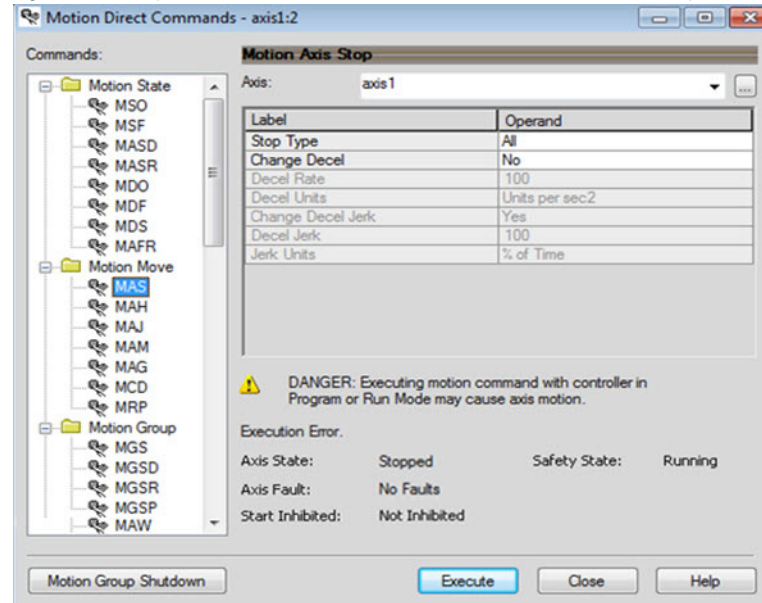

When the controller transitions to Program mode, the integrated safety drive is in the safe state (torque is not permitted). The controller reports Safety State = Not Running and Axis State = Start Inhibited, as shown in [Figure 10](#).

Figure 10 - Safety State Indications After Controller Transitions to Program Mode

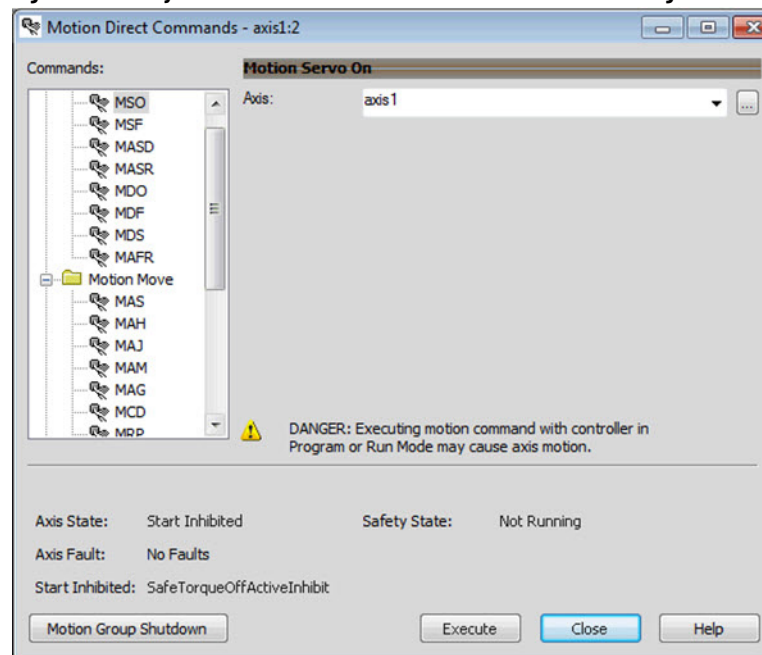

When you issue a motion direct command to an axis to produce torque in Program mode, for example MSO or MDS, with the safety connection present to the drive, a warning message is presented before the motion direct command is executed, as shown in [Figure 11 on page 62](#).

Figure 11 - STO Bypass Prompt When the Safety Controller is in Program Mode

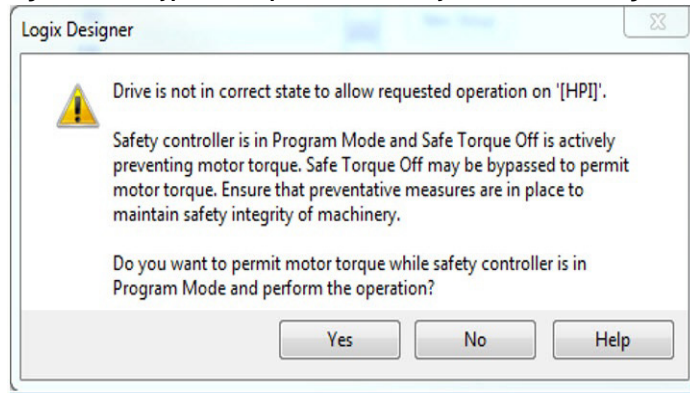

IMPORTANT The warning in [Figure 11 on page 62](#) is displayed only the first time a motion direct command is issued.

After you acknowledge the warning message by clicking Yes, torque is permitted by the drive and a warning message is indicated in the software as shown in [Figure 12 on page 62](#). The controller reports Safety State = Not Running (Torque Permitted), Axis State = Stopped/Running and Persistent Warning = Safe Torque Off Bypassed.

IMPORTANT Switch the controller to Run mode to exit Motion Direct Command mode and end the STO function bypass.

Figure 12 - Safety State Indications After Controller Transitions to Program Mode (MDC executing)

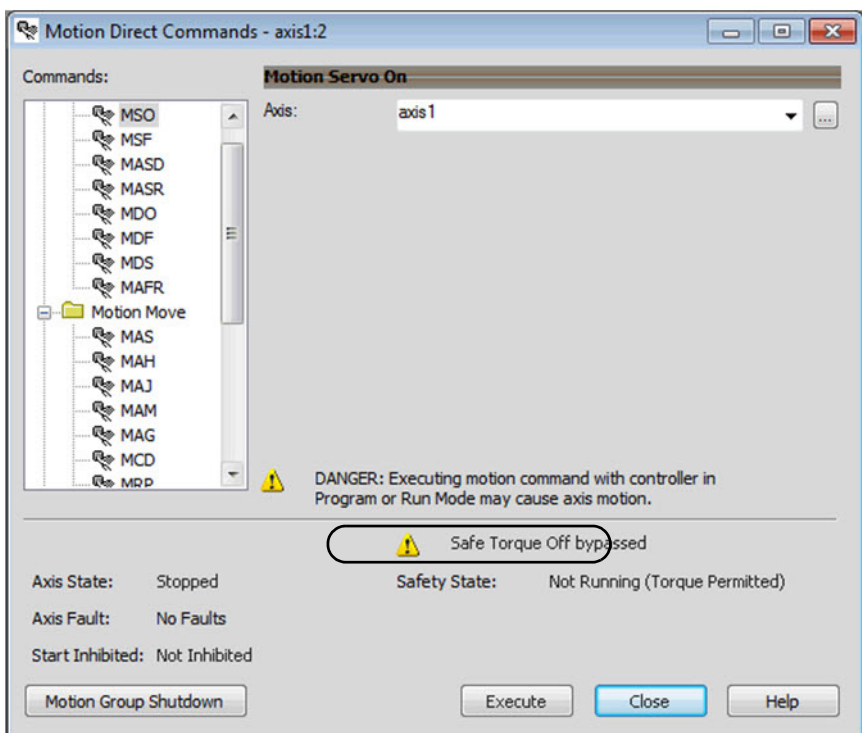

IMPORTANT

The persistent warning message text Safe Torque Off bypassed appears when a motion direct command is executed.

The warning message persists even after the dialog is closed and reopened as long as the integrated safety drive is in STO Bypass mode.

The persistent warning message is removed only after the integrated safety drive's Safety State is restored to the Running state.

Torque Permitted in a Multi-workstation Environment

The warning in [Figure 13 on page 63](#) is displayed to notify a second user working in a multi-workstation environment that the first user has placed the integrated safety drive in the STO state and that the current action is about to bypass the STO state and permit torque.

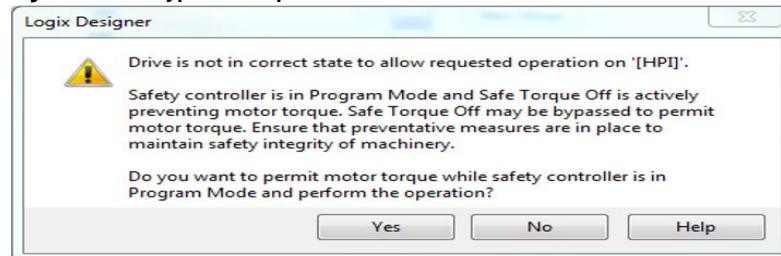
Figure 13 - STO Bypass Prompt When MDC is Issued in Multi-workstation Environment*Warning Icon and Text in Axis Properties*

In addition to the other warnings that require your acknowledgement, the Logix Designer application also provides warning icons and persistent warning messages in other Axis Properties dialog boxes when the integrated safety drive is in STO Bypass mode.

Figure 14 - Axis and Safe State Indications on the Hookup Services Dialog Box

Figure 15 - Axis and Safe State Indications on Motion Direct Commands Dialog Box

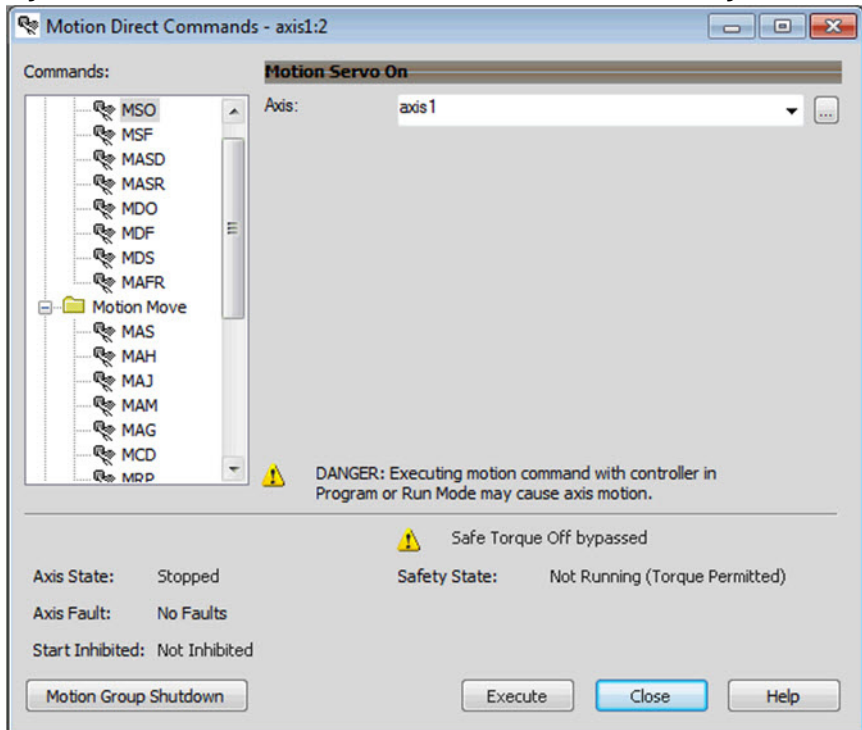
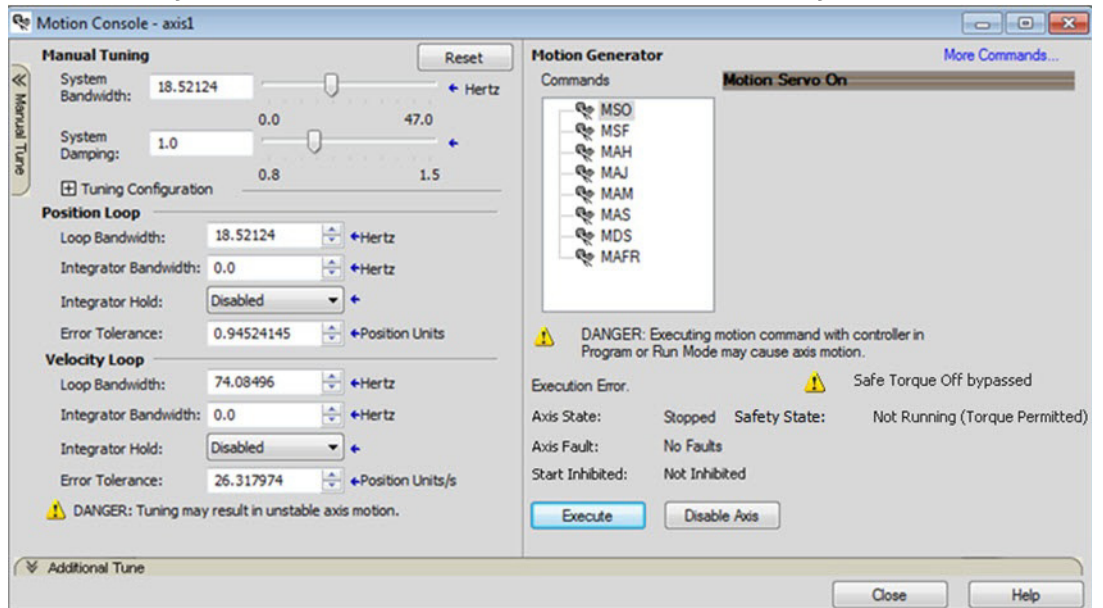

Figure 16 - Axis and Safe State Indications on the Motion Console Dialog Box



Functional Safety Considerations



ATTENTION: Before maintenance work can be performed in Program mode, the developer of the application must consider the implications of allowing motion through motion direct commands and should consider developing logic for runtime maintenance operations to meet the requirements of machine safety operating procedures.



ATTENTION: Motion is allowed and the STO function is not available when motion direct commands are used in Program mode. Motion direct commands issued when the controller is in Program mode cause the drive to bypass the STO Active condition. It is your responsibility to implement additional preventive measures to maintain safety integrity of the machinery during execution of motion direct commands in Program mode.



ATTENTION: To avoid personal injury and damage to equipment in the event of unauthorized access or unexpected motion during authorized access, return the controller to Run mode and remove the key before leaving the machine unattended.

Notes:

Hardwired STO Wiring and Operation

This chapter provides information for hardwired installation and operation of the Integrated Safety - Safe Torque Off option module.

Topic	Page
Wiring	67
Description of Hardwired Operation	68
Selection of Hardwired Operation	68
Configure the Drive with Hardwired Safety Connections	68
Timing Diagrams	69

Wiring

Observe these wiring guidelines when installing the safety option module:

- Use copper wire with an insulation rating of 600V or greater.
- Separate control wires from power wires by at least 0.3 m (1 ft).

Table 11 - Safety Option Module Terminal Block Specifications

Wire Size Range		Wire Type	Strip Length
Max	Min		
0.8 mm ² (18 AWG)	0.3 mm ² (28 AWG)	Multi-conductor shielded cable	10 mm (0.39 in.)

Integrated Safety - Safe Torque Off Option Module
(catalog numbers 20-750-S3, 20-750-S3-XT)

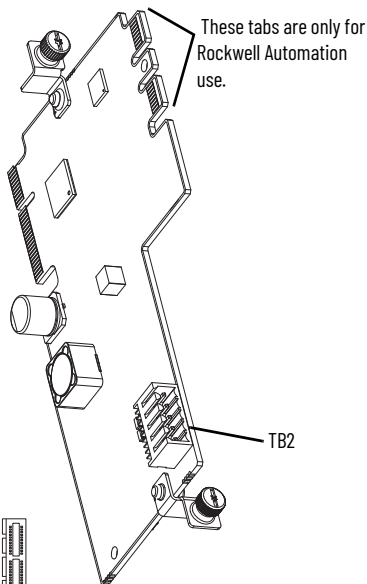

Table 12 - TB2 Terminal Designation

Terminal	Name	Description
Si0	Safety input 0	Safety input 0
SC	Safety common	Safety power common
Si1	Safety input 1	Safety input 1
SC	Safety common	Safety power common
SP	Safety power	+24V DC from customer-supplied SELV/PELV safety power

Safety Input	Connection Example
Power supply	

6 5 4

IMPORTANT The National Electrical Code and local electrical codes take precedence over the values and methods provided.

Cabling

- Safety input wiring must be protected against external damage by cable ducts, conduit, armored cable, or other means.
- Shielded cable is required. For proper shield termination, follow the installation requirements that are related to EN 61800-3 and the EMC Directive as described in these publications:
 - PowerFlex® 755 AC Drive Installation Instructions, publication [750-IN001](#)
 - PowerFlex 750-Series Products with TotalFORCE™ Control Installation Instructions, publication [750-IN100](#)
 - PowerFlex 755TS Products with TotalFORCE Control Installation Instructions, publication [750-IN119](#)

Power Supply Requirements

- The external power supply must conform to the Directive 2006/95/EC Low Voltage, by applying the requirements of EN61131-2 Programmable Controllers, Part 2 - Equipment Requirements and Tests, and one of the following:
 - EN 60950-1 or EN 62368-1 - SELV (Safety Extra Low Voltage)
 - EN 60204-1 - PELV (Protective Extra Low Voltage)
 - IEC 60536 Safety Class III (SELV or PELV)
 - UL 508 Limited Voltage Circuit
 - 24V DC $\pm 10\%$ must be supplied by a power supply that complies with IEC 60204-1 and EN 61558-1.

For more information, see the guidelines in Industrial Automation Wiring and Grounding Guidelines, publication [1770-4.1](#).

Description of Hardwired Operation

The Safe Torque Off feature provides a method, with sufficiently low probability of failure, to force the power-transistor control signals to a disabled state. If either hardwired safety input is de-energized, the drive output-power transistors are released from the On state. This release results in a condition where the drive coasts (stop category 0). Disabling the power transistor output does not provide mechanical isolation of the electrical output that is required for some applications.

Under normal operation, the Safe Torque Off inputs are energized. If either of the safety enable inputs are de-energized, then the output power transistors turn off. Parameter 933 [Start Inhibits] will indicate that IGBTs are inhibited and the HIM will indicate that the drive is not enabled.



ATTENTION: If any of the safety enable inputs de-energize, the Start Inhibit field indicates SafeTorqueOffInhibit. The input must be de-energized within 1 second and re-energized within 1 second to avoid a fault condition. See [Figure 7 on page 57](#).

Selection of Hardwired Operation

To select hardwired control of Safe Torque Off:

- The safety control must be in the out-of-box state. See [Restore the Drive to Out-of-Box State on page 26](#).
- An appropriate safety device must be connected to terminals Si0, Si1, and SP.

Configure the Drive with Hardwired Safety Connections

To add the 20-750-S3 peripheral device, and configure the safety connection, see these sections:

- [Add an Option Module to a PowerFlex 755/755T Drive Product in I/O Mode on page 33](#)
- [Generate the Safety Network Number \(SNN\) on page 33](#)

Timing Diagrams

Figure 17 on page 69 is a timing diagram for normal operation.

Figure 17 - System Operation When Inputs Are Meeting Timing Requirements

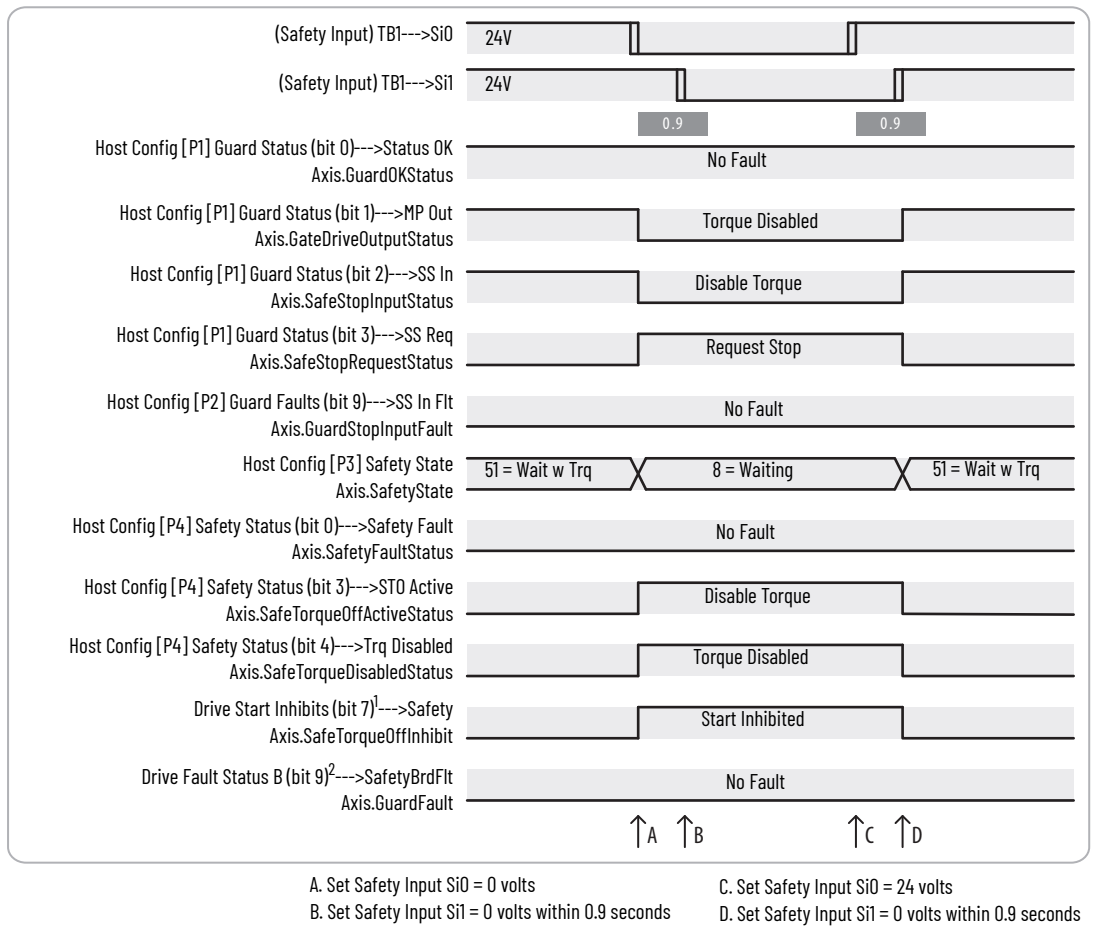

¹Drive Start Inhibits is parameter 933 in PowerFlex 755 drives and parameter 603 in PowerFlex 755T drive products.

²Drive Fault Status B is parameter 953 in PowerFlex 755 drives and parameter 462 in PowerFlex 755T drive products.

Figure 18 on page 70 demonstrates when a Safe Torque Off safety input mismatch is detected and a Fault is posted.

Figure 18 - System Operation in the Event That the Safety Enable Inputs Mismatch

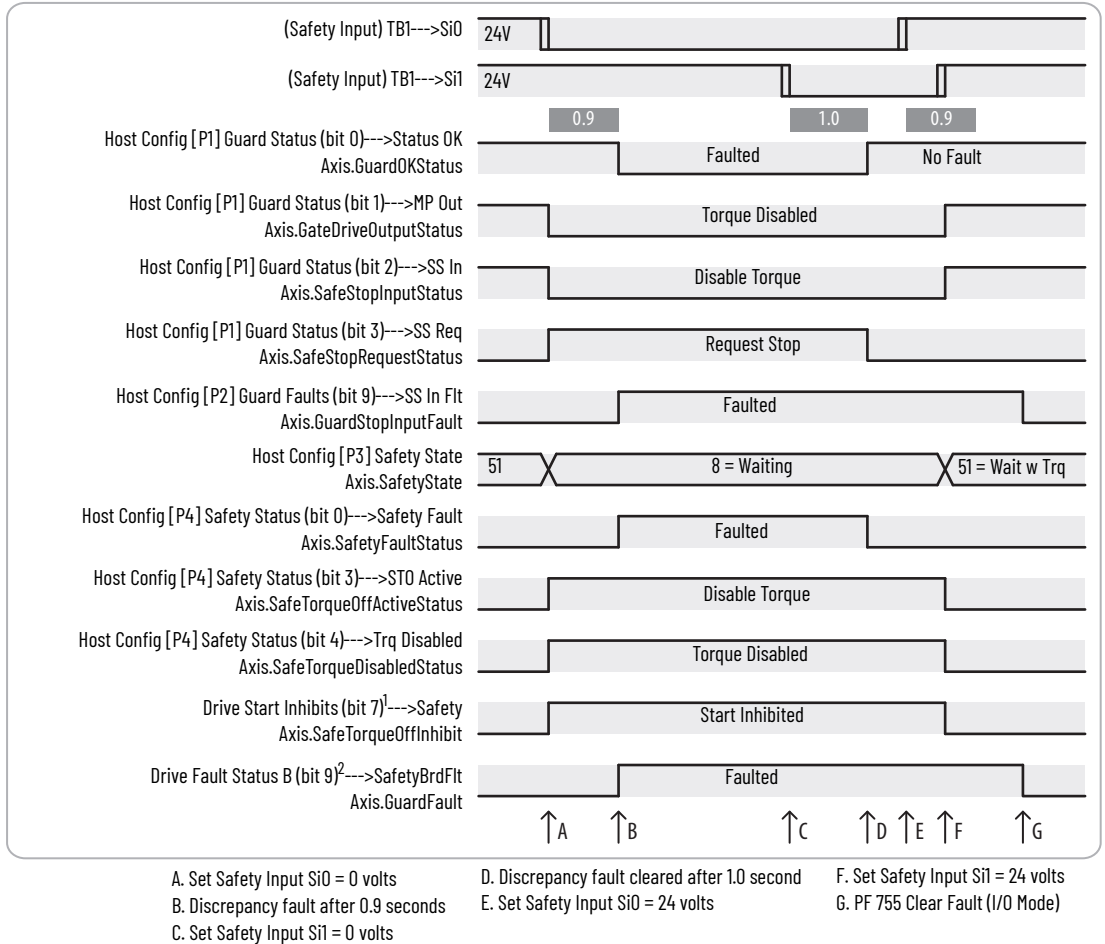

¹ Drive Start Inhibits is parameter 933 in PowerFlex 755 drives and parameter 603 in PowerFlex 755T drive products.

² Drive Fault Status B is parameter 953 in PowerFlex 755 drives and parameter 462 in PowerFlex 755T drive products.

Both Safe Torque Off safety inputs must turn off together, otherwise a fault is asserted. Figure 19 on page 71 shows the timing diagram when the safety inputs mismatch momentarily. A fault will be asserted even if the first safety input gets turned on again.

Figure 19 - System Operation in the Event That the Safety Enable Inputs Mismatch Momentarily

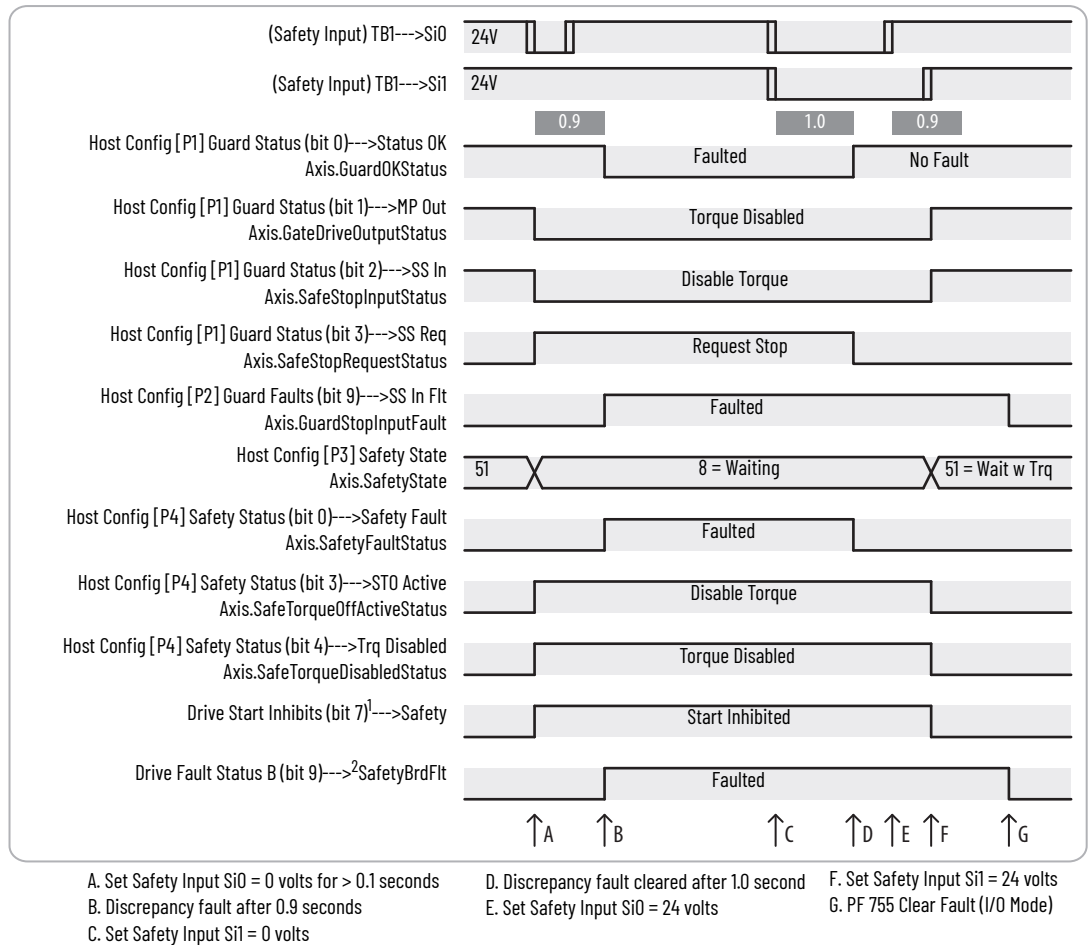

¹ Drive Start Inhibits is parameter 933 in PowerFlex 755 drives and parameter 603 in PowerFlex 755T drive products.
² Drive Fault Status B is parameter 953 in PowerFlex 755 drives and parameter 462 in PowerFlex 755T drive products.



ATTENTION: The STO fault is detected upon demand of the STO function. After troubleshooting, a safety function must be executed to verify correct operation.

IMPORTANT

A discrepancy STO fault type (102) can be reset by placing both inputs in the off state for more than one second. Any other STO fault types can only be cleared in hardwired STO mode by power cycling or resetting the device.

Notes:

Monitoring and Troubleshooting

This chapter provides information for monitoring and troubleshooting the Integrated Safety - Safe Torque Off option module.

Topic	Page
Monitor STO Status	73
Monitor STO With a HIM or Software	74

Monitor STO Status

The option module has three status indicators to provide status of the module, safety network, and motion output of the drive. When viewing the installed option module, the status indicators are arranged in this order (top to bottom):

- Module status (DS1)
- Network status (DS2)
- Motion output status (DS3)

IMPORTANT Status indicators are not reliable for safety functions. Use status indicators only for general diagnostics during commissioning or troubleshooting. Do not attempt to use status indicators to determine operational status.

Module Status Indicator (DS1)

[Table 13](#) provides information for the module status.

Table 13 - Module Status LED (DS1)

For Safety Supervisor State ⁽¹⁾	Status Indicator	Problem
No power	Off	No power is applied to drive.
Executing (4)	Green	Drive is operational. No faults or failures.
Idle state (2)	Flashing green	Standby (drive not configured).
Abort (5)	Flashing red	Major recoverable fault. The drive detected a recoverable fault.
Critical fault (6)	Red	The drive detected a non-recoverable fault.
Device self-test (1) Waiting (8) Configuring	Flashing red/ green	The drive performs self-test during power-up.
Firmware update in progress	Flashing red	Firmware update in progress.

(1) The numbers in parentheses are the values in the Host Config P[3] Safety State parameter.

Network Status Indicator (DS2)

[Table 14](#) provides information for the network status.

Table 14 - Network Status LED (DS2)

State	Status Indicator	Problem
Not powered/not online	Off	Device is not online.
No connections	Flashing green	Device is online but has no connections in the established state.
Connected	Green	Device is online and connections in the established state.
Connection timeout	Flashing red	One or more I/O connections are in the Timed-Out state.
Critical link failure	Red	Failed communication device. The device has detected an error that has rendered it incapable of communicating on the network.
Self-test	Flashing red/green	The device is performing its power-on test.
Firmware update in progress	Flashing red	Firmware update in progress.

Motion Output Status Indicator (DS3)

[Table 15](#) provides information for the motion output status.

Table 15 - Motion Output Status LED (DS3)

State	Status Indicator	Problem
Torque disabled	Off	Torque is disabled.
Torque permitted	Solid green	The STO circuit is permitting torque.
Circuit fault	Flashing red	The STO circuit is faulted.

Monitor STO With a HIM or Software

This section describes safety-related status information available for viewing with a HIM, drive module properties in the Logix Designer application, or Connected Components Workbench™ software.

Fault Messages on HIM, Drive Module, and Connected Components Workbench Software

The only message displayed for any fault originating from the module is 'SAFETY BRD FAULT' with a fault code of 211 for PowerFlex 755 drives and a code of F87 for PowerFlex 755T drives. This fault is displayed by the HIM, drive module, and Connected Components Workbench software. To determine the cause of the fault, read the value from STO Fault Type [P7] and see [Table 16](#) to determine possible troubleshooting steps based on fault type.

Table 16 - STO Fault Messages

STO Fault Type (Value)	Problem	Possible Solutions
Circuit Err(3)	Internal STO diagnostics has found an issue with STO circuitry.	<ul style="list-style-type: none"> • Cycle power (or perform fault reset if in network mode). • Execute STO function • Return module for repair if fault persists.
Stuck Low(4)	Internal STO Health and/or Power input stuck low.	<ul style="list-style-type: none"> • Cycle power (or perform fault reset if in network mode). • Execute STO function • Return module for repair if fault persists.

Table 16 - STO Fault Messages

STO Fault Type (Value)	Problem	Possible Solutions
Stuck High(5)	Internal STO Health and/or Power input stuck high.	<ul style="list-style-type: none"> • Cycle power (or perform fault reset if in network mode) • Execute STO function • Return module for repair if fault persists.
Discrepancy(102)	Difference detected between safety input values.	<ul style="list-style-type: none"> • Put both Safety inputs low for more than 1s to clear fault. • Check wiring of safety inputs if issue persists.
Mode Conflict(104)	Hardwired inputs are detected in network mode.	<ul style="list-style-type: none"> • Cycle Power (or perform fault reset). • Check to make sure there are no connections to the safety inputs.



ATTENTION: The status data that are described in this section is STANDARD data (not SAFETY data) and cannot be used as part of a safety function.

IMPORTANT Guard Status [P1] and Guard Faults [P2] only function in Hardwired mode (for backwards compatibility with previous hardwired safety modules).

For diagnostic purposes, you can also view status attributes by accessing these Host Config parameters (note: these are different than the 'Device Config' parameters) from a HIM, Connected Components Workbench software, or the Logix Designer application:

- Guard Status [P1]
- Guard Faults [P2]
- Safety State [P3]
- Safety Status [P4]
- Safety Faults [P5]

See [Table 17](#) through [Table 21 on page 76](#) for a description of these parameters.

Table 17 - Guard Status [P1]

Bit	Display Text	Description
0	Status OK	This bit indicates when there are no faults. This bit is set to 1 when the Fault Status bits 1...31 are 0 (no faults). This bit is 0 if any Fault Status bit from 1...31 indicates a fault (1).
2	MP Out	This bit shows the status of the safety option module Motion Power command to the drive. 1 = indicates that Motion Power is enabled. 0 = indicates that Motion Power is disabled.
3	SS In	This bit displays the logical value evaluated for the dual-channel SS_In input. 0 = Off 1 = On
4	SS Req	This bit indicates the status of the safe stop request. 0 = Inactive 1 = Active

Table 18 - Guard Faults [P2]

Value	Display Text	Description
1	Critical Flt	A nonrecoverable microprocessor error has occurred.
3	MP Out Flt	An MP Output fault occurs if an error is detected in the Motion Power command to the drive. An MP Out fault is cleared at power down or by a successful reconfiguration.
9	SS In Flt	An error was detected in the safe stop input.

Table 19 - Safety State [P3]

Value	Display Text	Description	Mode
1	Testing	Device is performing test diagnostics	Networked/Hardwired
2	Idle	No active connections	Networked
3	Test Flt	A fault has occurred while executing test diagnostics	Networked/Hardwired
4	Executing	Normal running state	Networked
5	Abort	A major recoverable fault has occurred	Networked/Hardwired
6	Critical Flt	A critical fault has occurred	Networked/Hardwired
7	Configuring	Transition state.	Networked
8	Waiting	Out-of-box state	Hardwired
51	Wait w Trq	Out-of-box state	Hardwired
52	Exec w Trq	STO bypass state (Not currently supported. Reserved for future revision for CIP Motion™.)	Networked

Table 20 - Safety Status [P4]

Bit	Display Text	Description
0	Safety Fault	Indicates the existence of a safety fault 0 = no fault 1 = faulted
1	Safety Reset	A transition from 0 to 1 resets the safety function.
2	Restart Req	Indicates whether a manual restart is required following a stop function, 0 = restart not required 1 = restart required
3	STO Active	Indicates whether STO control is active. 0 = Not Active (Permit Torque) 1 = Active (Disable Torque)
4	Trq Disable	Displays the status of STO control 0 = Torque Permitted 1 = Torque Disabled
30	Conn Closed	No active connection of an output assembly from the safety controller exists.
31	Conn Idle	An active output assembly connection exists but the safety controller is in Program mode.

Table 21 - Safety Faults [P5]

Bit	Display Text	Description
1	Core Fault	Internal STO circuitry fault
3	STO Fault	This bit indicates the fault status of the STO function. 0 = no fault 1 = faulted The cause of the fault is recorded in the Device Config STO Fault Type [P7] status parameter.

IMPORTANT If the STO Fault bit is set, you can read the value of the Device Config STO Fault Type [P7] parameter to determine the type of fault.

A hardwired input discrepancy occurs when the values of the two hardwired inputs differ for greater than 1 second. To recover from this fault, de-energize both inputs for 1 second and issue a drive fault clear command to clear the latched fault in the drive.

A hardwired safety input that is detected while in network mode causes a fault. Only one mode, hardwired or safety, can be used. If network safety is used, no wiring should be present on the terminal block of 20-750-S3.

Safety Supervisor State

The Safety Supervisor State provides information on the state of the safety connection and the mode of operation. It can be read in the user's Logix program via the MSG instruction.

Table 22 - Safety Supervisor State: MSG

Parameter	Value	Description
Service Code	0x0E	Get Attribute Single
Class	0x39	Safety Supervisor
Instance	1	-
Attribute	0x0B	Device Status
Data Type	SINT	Unsigned Short Integer

For Safety State [P3] information, see [Table 19 on page 76](#).

Safe Torque Off Faults

When a safety fault is indicated in the SI.SafetyFault tag, you can also use an MSG instruction to read the cause of the fault.

Table 23 - Safe Torque Off Fault Type: MSG

Parameter	Value	Description
Service Code	0x0E	Get Attribute Single
Class	0x5A	Safety Stop Functions
Instance	1	Axis number
Attribute	0x108	STO Fault Type
Data Type	SINT	Unsigned Short Integer

Notes:

Specifications, Certifications, CE, and UKCA Conformity

This appendix provides general specifications for the Integrated Safety - Safe Torque Off option module.

Topic	Page
Integrated Safety - Safe Torque Off Option Module Specifications	79
Environmental Specifications	80
Certifications	81

Integrated Safety - Safe Torque Off Option Module Specifications

These specifications apply to the Integrated Safety - Safe Torque Off option module. For additional specifications, see these publications:

- PowerFlex® 755 AC Drives Technical Data, publication [750-TD001](#)
- PowerFlex 750-Series Products with TotalFORCE™ Control Technical Data, publication [750-TD100](#)
- PowerFlex 755TS Products with TotalFORCE Control Technical Data, publication [750-TD104](#)

General Specifications

Attribute	Value
Standards (when used with PowerFlex 755)	EN 61800-5-2, EN 61800-5-1, EN 61800-3, EN ISO 13849-1, EN 62061, EN 60204-1, IEC 61508 parts 1-7
Safety ratings (when used with PowerFlex 755)	SIL 3 according to EN 62061 / IEC 61508 SIL CL 3 according to EN 61800-5-2 / EN 62061 / IEC 61508 Cat. 3 and PL e according to EN ISO 13849-1
Standards (when used with PowerFlex 755T)	EN 61800-5-2, EN 61800-5-1, EN 61800-3, EN ISO 13849-1, EN 62061, EN 60204-1, IEC 61508 parts 1-7
Safety ratings (when used with PowerFlex 755T)	SIL 3 according to EN 62061 / IEC 61508 SIL CL 3 according to EN 61800-5-2 / EN 62061 / IEC 61508 Cat. 3 and PL e according to EN ISO 13849-1
Power supply (user I/O)	24V DC ±10%, 0.8...1.1 x rated voltage ⁽²⁾ PELV or SELV
Input type	Current sinking
Voltage, on-state input	11...30V, 3.5 mA DC
Voltage, off-state input, max	5V, 3.5 mA DC
Current, on-state input, min	3.3 mA
Current, off-state, max	1.5 mA
IEC 61131-2 (input type)	Type 3
Conductor type	Multi-conductor shielded cable
Conductor size ⁽¹⁾	0.3...0.8 mm ² (28...18 AWG)
Strip length	10 mm (0.39 in.)
Recovery time (approximate time before drive can start after the torque enable request is made)	Hardwired STO mode: 200 ms Network STO mode: 100 ms

(1) See the Industrial Automation Wiring and Grounding Guidelines, publication [1770-4.1](#).

(2) Safety outputs need additional fuse for reverse voltage protection of the control circuit. Install a 6 A slow-blow or 10 A fast-acting fuse.

Environmental Specifications

The installation must comply with all environmental, pollution degree, and drive enclosure rating specifications required for the operating environment.

Category	Specification
Ambient temperature	For detailed information on environmental, pollution degree, and drive enclosure rating specifications, see the technical data publication for your drive. <ul style="list-style-type: none"> • PowerFlex 750-Series AC Drives Technical Data, publication 750-TD001 • PowerFlex 750-Series Products with TotalFORCE Control Technical Data, publication 750-TD100 • PowerFlex 755TM IP00 Open Type Kits Technical Data, publication 750-TD101 • PowerFlex 755TS Products with TotalFORCE Control Technical Data, publication 750-TD104
Storage temperature	
Shock Operating Packaged for shipment	
Vibration Operating Packaged for shipment Sinusoidal loose load Random secured	
Surrounding environment	
Corrosive Atmosphere (20-750-S3-XT) <ul style="list-style-type: none"> • ASTM B845-97 Method K Accelerated Test (30 day exposure) • Plus additional Rockwell Automation proprietary accelerated corrosion testing protocol for specific industries with sources of gaseous sulfur compounds, including tire and rubber. 	Severity Level GX per ANSI/ISA 71.03-2013, airborne contaminants-gases. Severity level GX is defined as up to 2100 angstroms of film growth per 30 days of copper or silver reactivity. Severity Level CX per IEC 60721-3-3: 2019, Chemically Active Substances. For the product to meet the corrosive atmosphere rating, these conditions must be met: <ul style="list-style-type: none"> • The PowerFlex 755T product has the Corrosive Gas Protection (XT) option. • Protective covers must remain installed in unused connectors during storage and operation. • The product or kit must be stored in the original packaging.



ATTENTION: Failure to maintain the specified ambient temperature can result in a failure of the safety function.

IMPORTANT

Products with a safety function installed must be protected against conductive contamination by one of the following methods:

- Select a product with an enclosure type of at least IP54, NEMA/UL Type 12
- Provide an environmentally controlled location for the product that does not contain conductive contamination

Environmental Pollution Degree Description (EN 61800-5-1)

Surrounding Environment Pollution Degree	Conductive Contamination Allowed by Pollution Degree	Acceptable Enclosures
Pollution degree 1 and 2	No possibility of conductive dust.	All enclosures are acceptable.
Pollution degree 3 and 4	The possibility of conductive dust is allowed.	Enclosure that meets or exceeds IPS4, NEMA/UL Type 12 is required.

Certifications

See the Product Certifications website, rok.auto/certifications for Declarations of Conformity, Certificates, and other certifications details.

Certification ⁽¹⁾	Value
cULus ⁽²⁾	UL Listed, certified for US and Canada
CE	European Union and 2014/30/EU EMC Directive, compliant with: EN 61800-3; PowerFlex 750-Series AC Drive, Emissions and Immunity EN 62061; Safety Function, Immunity European Union 2006/42/EC Machinery Directive: EN ISO 13849-1; Safety Function EN ISO 13849-2; Safety Function EN 60204-1; Safety Function EN 62061; Safety Function EN 61800-5-2; Safety Function
UKCA	UK Electromagnetic Compatibility Regulations (EMC) 2016 No. 1091, compliant with: EN 61800-3; PowerFlex 750-Series EN 62061; Safety Function, Immunity AC Drive, Emissions, and Immunity UK Supply of Machinery (Safety) Regulations (MD) 2008 No. 1597: EN ISO 13849-1; Safety Function EN ISO 13849-2; Safety Function EN 60204-1; Safety Function EN 62061; Safety Function EN 61800-5-2; Safety Function
RCM	Australian Radiocommunications Act, compliant with: EN 61800-3; categories C2 and C3
TÜV Rheinland	Certified by TÜV Rheinland for Functional Safety: Up to SIL 3, according to EN 61800-5-2 and IEC 61508, and SIL CL3 according to EN IEC 62061; Up to Performance Level PLe and Category 3, according to EN ISO 13849-1; When used as described in this PowerFlex 755 Integrated Safety - Safe Torque Off User Manual.

(1) See the Product Certification link at rok.auto/certifications for Declarations of Conformity, Certificates, and other certifications details.

(2) Underwriters Laboratories Inc. has not evaluated the Integrated Safety - Safe Torque Off, or Safe Speed Monitor option modules for functional safety.

Waste Electrical and Electronic Equipment (WEEE)



At the end of its life, this equipment should be collected separately from any unsorted municipal waste.

Notes:

STO Option Module Replacement Considerations

This appendix provides a comparison of the differences between the Safe Torque Off option module (catalog number 20-750-S) and the new Integrated Safety - Safe Torque Off option module (catalog numbers 20-750-S3, 20-750-S3-XT).

Topic	Page
Installation Considerations	83
Wiring	83

Installation Considerations

This section provides information for differences between the Safe Torque Off option modules.

Option Module Slots

The Integrated Safety - Safe Torque Off option module (catalog numbers 20-750-S3, 20-750-S3-XT) can be installed in slots 4, 5, or 6.

The Safe Torque Off option module (catalog number 20-750-S) can be installed in slots 4...8.

Wiring

The wiring and terminal blocks for the option modules are different.

Safe Torque Off Option Module

This section describes the terminal block and power supply for the Safe Torque Off option module.

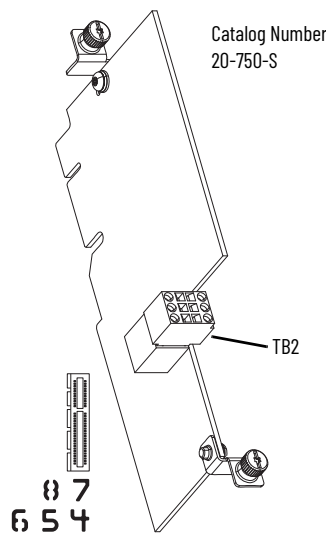

TB2 Terminal Designation

Terminal	Name	Description
SP+	+24 Volt Safety Power	User-supplied power: 24 volt \pm 10% 45 mA typical
SP-	Safety Power Common	
SE+	+24 Volt Safety Enable	User-supplied power: 24 volt \pm 10% 25 mA typical
SE-	Safety Enable Common	
Sd	Shield	Terminating point for wiring shields when an EMC plate or conduit box is not installed.
Sd	Shield	

Safety Input

Connection Example

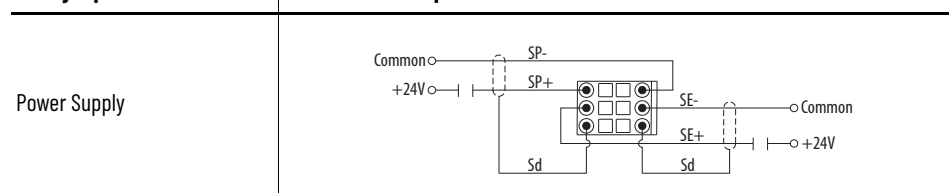

Integrated Safety - Safe Torque Off Option Module

This section describes the terminal block and power supply for the Integrated Safety - Safe Torque Off option module.

Catalog Numbers 20-750-S3, 20-750-S3-XT

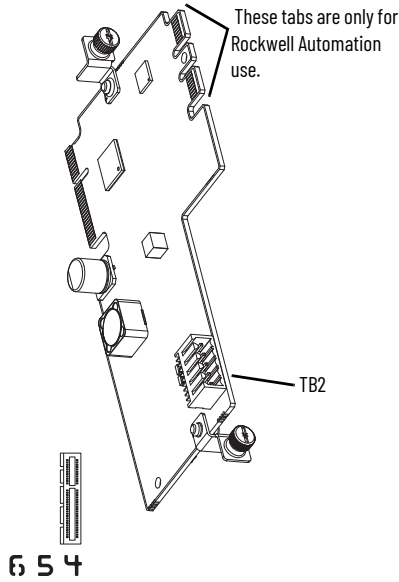

TB2 Terminal Designation

	Terminal	Name	Description
	Si0	Safety input 0	Safety input 0
	SC	Safety common	Safety power common
	Si1	Safety input 1	Safety input 1
	SC	Safety common	Safety power common
	SP	Safety power	+24V DC from customer-supplied SELV/PELV safety power

Safety Input	Connection Example
Power Supply Safety Input 0 Safety Common Safety Input 1 Safety Common Safety Power	

Parameter Data

This appendix provides a description of the device config parameters and host config parameters.

Parameters and Settings in a Linear List

This section lists the configurable parameters and their valid settings in numerical order.

Device Config Parameters

These parameters are part of the device configuration parameters.

Device Config Parameters

No.	Display Name Full Name Description	Values	Description	Data Type
1	Identity Status Describes the status of the module.	"Owned" (0)	Indicates whether the safety option module has an owner. 1 = owned 0 = not owned	DWORD
		"Configured" (2)	Indicated whether the safety option module has a configuration other than out-of-box. 1 = configured 0 = out of box configuration	
		"Min Rec Flt" (8)	If set (1), the safety option module has detected a minor recoverable fault. The device does not enter a faulted state.	
		"Min Unr Flt" (9)	If set (1), the safety option module has detected a minor unrecoverable fault. The device does not enter a faulted state.	
		"Maj Rec Flt" (10)	If set (1), the safety option module has detected a major recoverable fault and is in the major recoverable fault state.	
		"Maj Unr Flt" (11)	If set (1), the safety option module has detected a major unrecoverable fault is in the major unrecoverable fault state.	
2	Extended Status Detailed description of the module status based on Identity State.	"Self Test" (0)	A self test is in progress.	USINT
		"FW Update" (1)	A firmware update is in progress.	
		"IO Faulted" (2)	At least one I/O connection is faulted.	
		"No IO Conect" (3)	No I/O connections are established.	
		"Config Err" (4)	Non-volatile configuration is bad.	
		"Major Flt" (5)	A major fault has occurred.	
		"IO In Run" (6)	At least one I/O connection is in Run mode.	
"IO In Idle" (7)	At least one I/O connection is in Idle mode.			

Device Config Parameters (Continued)

No.	Display Name Full Name Description	Values	Description	Data Type
3	Identity State State of the module.	"Invalid" (0)	The device is without power.	USINT
		"Self Test" (1)	The device is executing self tests.	
		"Standby" (2)	The device has incorrect or incomplete configuration.	
		"Operational" (3)	The device is currently operating in normal fashion.	
		"Maj Rec Flt" (4)	The device has experienced a fault that is recoverable.	
		"Maj Unr Flt" (5)	Device has encountered a fault that is unrecoverable.	
4	Max Data Age Maximum data age	-	Holds the largest data age detected in 128 µs increments.	UINT
5	Cons Flt Count Consumer connection fault count	-	The number of faults detected in this hour from the consumer connection.	UINT
6	Prod Flt Count Producer connection fault count	-	The number of faults detected in this hour from the producer connection.	UINT
7	STO Fault Code Indicates the current STO fault type of the module.	"No Fault" (1)	STO functions are not faulted.	USINT
		"Circuit Err" (3)	Internal STO circuitry error.	
		"Stuck Low" (4)	Internal STO Health and/or Power input stuck low.	
		"Stuck High" (5)	Internal STO Health and/or Power input stuck high.	
		"Discrepancy" (102)	Hardwired input discrepancy.	
		"Mode Conflict" (104)	Hardwired input is detected in Network mode.	
8	Safety In Values Current value of the safety inputs.	"In0 Value" (0)	Safety Input 0 Value 0 = Off 1 = On	BYTE
		"In1 Value" (1)	Safety Input 1 Value 0 = Off 1 = On	
9	Safety In Status Current status of the safety inputs.	"In0 Status" (0)	Safety Input 0 Status 0 = Fault/Alarm has occurred 1 = OK	BYTE
		"In1 Status" (1)	Safety Input 1 Status 0 = Fault/Alarm has occurred 1 = OK	

Host Config Parameters

These parameters are part of the host configuration parameters.

Notes:

History of Changes

Change Log

This appendix contains the new or updated information for each revision of this publication. These lists include substantive updates only and are not intended to reflect all changes. Translated versions are not always available for each revision.

750-UM004B-EN-P, October 2018

Change

Added information about Integrated Motion

750-UM004C-EN-P, August 2019

Change

Added additional frame sizes to Table 3 and Table 4

Updated screen captures to reflect latest add-on profile (AOP)

Added additional information about using the 20-750-ENETR Dual-port EtherNet/IP option module with the Integrated Safety - Safe Torque Off option module

750-UM004D-EN-P, February 2021

Change

Added attention statement regarding ambient temperature to Environmental Specifications in Appendix A

750-UM004E-EN-P, December 2021

Change

Added catalog number 20-750-S3-XT to preface

Added Corrosive Atmosphere (20-750-S3-XT) information row to the Environment specification table

750-UM004F-EN-P, April 2022

Change

Changed PFD to PFD_{avg}

Added PowerFlex 755 TS drives to Conventions section

Added PowerFlex 755TS Products with TotalFORCE Control Installation Instructions, publication 750-IN119 to the Additional Resources table

Added PowerFlex 755TS low power single drive to Compatible Drives section

Added PowerFlex 755TS drive products, AOP version 15.01 (or later) to Compatible Drives section

Added new table for PFD_{avg} and PFH for PowerFlex 755TS Drive Products to PFD_{avg} and PFH Data section

Added row for PowerFlex TS drives to Safety Reaction Time table in Reaction Time in Network STO Mode section

Added PowerFlex 755TS Drive Jumper Location figure to Set the Safety Jumper section

Added PowerFlex 755TS v11 firmware (or later) row to Requirements section

750-UM004G-EN-P, October 2022

Change

Updated Power Supply Requirements certification information

Updated fault message between PowerFlex 755 and PowerFlex 755T

Updated General Specification information to change IEC to EN where applicable

Added UKCA certification information, and changed C-Tick to RCM

750-UM004H-EN-P, July 2023

Change

Updated configuration steps for the hardware enable and safety enable jumpers

This publication was updated to include information for the PowerFlex 755TS drive and the safety option card version with enhanced corrosive gas protection, catalog number 20-750-S3-XT

750-UM004I-EN-P, January 2025

Change

PowerFlex 755TR liquid cooled drive, frame 6L added to Table 2

PowerFlex 755TS frame 7A added to Table 3

PowerFlex 755TR liquid cooled drive, frame 6L added to Table 4

PowerFlex 755TS frame 7A added to Table 4

Numerics

20-750-S 12, 83
20-750-S1 12
20-750-S3 12, 67, 83, 84
20-750-S3-XT 67, 83, 84

A

additional resources 9

assembly

connections
 input 48
 output 48
tags
 SI.ConnectionStatus tags 30
 SI.Status tags 30
 S0.Command tags 30

C

cable 68
category 0 stop 41, 55
category 1 stop 42, 55
coast to stop 17
compatible drives 12
configuration ownership 41, 45, 54
Configure Always feature 46
connection reaction time limit 38, 54
connection type
 description 31, 50
controllers
 Compact GuardLogix 5370 13
 Compact GuardLogix 5380 13
 GuardLogix 5570 13
 GuardLogix 5580 13

D

diagnostics 75
documentation
 additional resources 9
drive replacement
 integrated safety 45, 58
DS1 73
DS2 73
DS3 73
duplicate device numbers 45

E

encoder wiring 83
external power supply 68

F

failure analysis 17
falling edge signals 42, 56

fault

code
 211 74
condition
 STO 44
detection
 spurious 17
messages 74

firmware revision 9

function response time 29

functional proof test 15

G

gate firing circuits 11

H

hazard prevention 14

I

IGBT 11

failure 12, 25

input

assembly connections 48
assembly tag 44
power
 turn off before maintenance 11, 25

integrated STO mode

drive replacement 45, 58
operation 47
STO bypass 60
STO state reset 57

IP address 51

J

jumper

locations
 PowerFlex 755 drives 21
 PowerFlex 755T drive products 21
settings 19

L

LEDs

module status 73
motion output status 74
network status 74

Logix Designer tag name 30, 48

M

maintenance

turn input power off 11, 25

mapping

safety tags 43, 56

mechanical brakes 14

mechanical force

- back pressure 12
- suspended loads 12

mission time 15**motion and safety connection** 50**motion connection** 50**motion direct commands**

- STO bypass 60
- warning messages 61

MSG command 26**N****network delay multiplier** 38, 54**new**

- module definition 32, 51

O**Off state** 12, 25**On state** 68**One Shot Falling instruction** 42, 56**out-of-box state**

- restore 26
- verify 26

output assembly connections 48**P****diagnostic parameters**

- guard status 75
- guard faults 76
- safety state 76
- safety status 76
- safety faults 76

parameters

- device 85
- host 86

PFD 15**PFD and PFH**

- PowerFlex 755 drives 15
- PowerFlex 755T drive products 16

power supply

- external 68

product compatibility and download center 9**proof test interval** 15**proof testing** 14**R****reaction times** 16**release note** 9**replace**

- PowerFlex 755 drive
 - on an integrated safety network 45
- safety devices 45
- safety I/O device 46

requested packet interval 36, 53**risk assessment** 14, 15, 19**RPI** 36, 38, 48, 53, 54**S****safe torque off**

- fault type
 - MSG 77

safe torque-off

- integrated STO mode
 - STO bypass 60
 - STO state reset 57
 - troubleshooting 58

safeguarding devices 14**safety**

- analysis 19
- category 79
- control state 26
- DeviceID 45
- fault 77
- function testing 19
- network number 13, 45
- network number, edit 52
- performance level 14
- rating 14, 17
- reaction time 16, 17
- reset 26
- routines 43, 56
- signature 13
- supervisor state 77
 - MSG 77
- supervisor status 26
- system requirements 13
- tag mapping 43, 56
- tags 30, 43, 48, 56
- task 46
- task signature 46

SAFETY BRD FAULT 74**safety only connection** 31, 50**shielded cable** 68**SI.ConnectionStatus tags** 30, 48**SI.Status tags** 30, 48**SIL 3 integrity safety data** 30, 48**SNN** 33, 45, 52**S0.Command tags** 30, 48**S0.SafeTorqueOff** 48**spurious fault detection** 17**standard**

- tags 43, 56

standard and safety connection 31**standard connection** 31**standard data**

- in a safety routine 43, 56
- in a safety tag 43, 56

start inhibits 25**status**

- attributes 75
- indicators 73
- LEDs
 - module status (DS1) 73
 - motion output status (DS3) 74
 - network status (DS2) 74

STO

- fault
 - condition 44
 - reset 44
- fault messages 74
 - Circuit Err(3) 74
 - Discrepancy(102) 75

- Mode Conflict(104) 75
- Stuck High(5) 75
- Stuck Low(4) 74
- fault type 74
- function response time 29, 47
- stop category**
 - 0 14, 25, 68
 - 1 14
 - 2 14
- stored energy** 12, 25
- suspended loads** 14
- synchronize actions** 43, 56
- system**
 - reaction times 16
 - safety considerations 14

T

- timeout multiplier** 38, 54
- troubleshooting**
 - safe torque-off
 - integrated STO mode 58

W

- Wait w Trq** 26
- Waiting** 26
- wiring** 19, 68
 - encoder 83
- wiring guidelines** 67

Notes:

Rockwell Automation Support

Use these resources to access support information.

Technical Support Center	Find help with how-to videos, FAQs, chat, user forums, Knowledgebase, and product notification updates.	rok.auto/support
Local Technical Support Phone Numbers	Locate the telephone number for your country.	rok.auto/phonesupport
Technical Documentation Center	Quickly access and download technical specifications, installation instructions, and user manuals.	rok.auto/techdocs
Literature Library	Find installation instructions, manuals, brochures, and technical data publications.	rok.auto/literature
Product Compatibility and Download Center (PCDC)	Download firmware, associated files (such as AOP, EDS, and DTM), and access product release notes.	rok.auto/pcdc

Documentation Feedback

Your comments help us serve your documentation needs better. If you have any suggestions on how to improve our content, complete the form at rok.auto/docfeedback.

Waste Electrical and Electronic Equipment (WEEE)



At the end of life, this equipment should be collected separately from any unsorted municipal waste.





Rockwell Automation maintains current product environmental compliance information on its website at rok.auto/pec.

Allen-Bradley, Connected Components Workbench, CompactLogix, ControlLogix, expanding human possibility, GuardLogix, PowerFlex, Rockwell Automation, Studio 5000 Logix Designer, and TotalFORCE are trademarks of Rockwell Automation, Inc.

CIP Motion, CIP Safety, and EtherNet/IP are trademarks of ODVA, Inc.

Trademarks not belonging to Rockwell Automation are property of their respective companies.

Rockwell Otomasyon Ticaret A.Ş. Kar Plaza İş Merkezi E Blok Kat:6 34752, İçerenköy, İstanbul, Tel: +90 (216) 5698400 EEE Yönetmeliğine Uygundur

Connect with us.    

rockwellautomation.com ————— **expanding human possibility®**

AMERICAS: Rockwell Automation, 1201 South Second Street, Milwaukee, WI 53204-2496 USA, Tel: (1) 414.382.2000

EUROPE/MIDDLE EAST/AFRICA: Rockwell Automation NV, Pegasus Park, De Kleetlaan 12a, 1831 Diegem, Belgium, Tel: (32) 2663 0600

ASIA PACIFIC: Rockwell Automation SEA Pte Ltd, 2 Corporation Road, #04-05, Main Lobby, Corporation Place, Singapore 618494, Tel: (65) 6510 6608

UNITED KINGDOM: Rockwell Automation Ltd., Pitfield, Kiln Farm, Milton Keynes, MK11 3DR, United Kingdom, Tel: (44)(1908) 838-800

Publication 750-UM004J-EN-P - January 2026

Supersedes 750-UM004I-EN-P - January 2025

Copyright © 2026 Rockwell Automation, Inc. All rights reserved. Printed in the U.S.A.