



Replacement Guidelines: Logix 5000 Controllers

ControlLogix 5580 to ControlLogix 5590

ControlLogix 5570 to ControlLogix 5580

ControlLogix 5570 Redundant to ControlLogix 5580 Redundant

GuardLogix 5570 to GuardLogix 5580

CompactLogix 5370 to CompactLogix 5380

Compact GuardLogix 5370 to Compact GuardLogix 5380

CompactLogix 1768-L4 to CompactLogix 5380

Compact GuardLogix 1768-L4 to Compact GuardLogix 5380

CompactLogix 1769-L3 to CompactLogix 5380



Allen-Bradley

by ROCKWELL AUTOMATION

Reference Manual

Original Instructions

Important User Information

Read this document and the documents listed in the additional resources section about installation, configuration, and operation of this equipment before you install, configure, operate, or maintain this product. Users are required to familiarize themselves with installation and wiring instructions in addition to requirements of all applicable codes, laws, and standards.

Activities including installation, adjustments, putting into service, use, assembly, disassembly, and maintenance are required to be carried out by suitably trained personnel in accordance with applicable code of practice.

If this equipment is used in a manner not specified by the manufacturer, the protection provided by the equipment may be impaired.

In no event will Rockwell Automation, Inc. be responsible or liable for indirect or consequential damages resulting from the use or application of this equipment.

The examples and diagrams in this manual are included solely for illustrative purposes. Because of the many variables and requirements associated with any particular installation, Rockwell Automation, Inc. cannot assume responsibility or liability for actual use based on the examples and diagrams.

No patent liability is assumed by Rockwell Automation, Inc. with respect to use of information, circuits, equipment, or software described in this manual.

Reproduction of the contents of this manual, in whole or in part, without written permission of Rockwell Automation, Inc., is prohibited.

Throughout this manual, when necessary, we use notes to make you aware of safety considerations.



WARNING: Identifies information about practices or circumstances that can cause an explosion in a hazardous environment, which may lead to personal injury or death, property damage, or economic loss.



ATTENTION: Identifies information about practices or circumstances that can lead to personal injury or death, property damage, or economic loss. Attentions help you identify a hazard, avoid a hazard, and recognize the consequence.

IMPORTANT

Identifies information that is critical for successful application and understanding of the product.

These labels may also be on or inside the equipment to provide specific precautions.



SHOCK HAZARD: Labels may be on or inside the equipment, for example, a drive or motor, to alert people that dangerous voltage may be present.



BURN HAZARD: Labels may be on or inside the equipment, for example, a drive or motor, to alert people that surfaces may reach dangerous temperatures.



ARC FLASH HAZARD: Labels may be on or inside the equipment, for example, a motor control center, to alert people to potential Arc Flash. Arc Flash will cause severe injury or death. Wear proper Personal Protective Equipment (PPE). Follow ALL Regulatory requirements for safe work practices and for Personal Protective Equipment (PPE).

The following icon may appear in the text of this document.



Identifies information that is useful and can help to make a process easier to do or easier to understand.

Rockwell Automation recognizes that some of the terms that are currently used in our industry and in this publication are not in alignment with the movement toward inclusive language in technology. We are proactively collaborating with industry peers to find alternatives to such terms and making changes to our products and content. Please excuse the use of such terms in our content while we implement these changes.

	Preface	
	About This Manual	9
	Download Firmware, AOP, EDS, and Other Files	9
	Summary of Changes	10
	Additional Resources	11
	Chapter 1	
Before You Begin a Migration	ControlLogix 5590 Controllers	14
	Enhanced Performance and Capacity	14
	Security Certification	14
	EtherNet/IP Network Functionality	14
	Safety Applications	14
	Harsh Environments	15
	Process Applications	15
	Migrate to 5590 Controller Applications	15
	Considerations	16
	Features on ControlLogix Controllers	17
	Features on CompactLogix Controllers	20
	Integrated Architecture Tools	22
	Migration Services	22
	Chapter 2	
Replacement Considerations with ControlLogix 5580 and GuardLogix 5580 Systems	Minimum Requirements	24
	ControlLogix Controllers Minimum Requirements	24
	GuardLogix Controllers Minimum Requirements	24
	Product Comparison	24
	ControlLogix Controllers	24
	GuardLogix Controllers	26
	Controller Dimensions	29
	ControlLogix 5570 Dimensions	29
	ControlLogix 5580 Dimensions	29
	GuardLogix 5570 Dimensions	30
	GuardLogix 5580 Dimensions	30
	Connectors and Status Indicators	31
	Configure the Controller	33
	Connections Overview	33
	Nodes on an EtherNet/IP Network	33
	New Project Dialog Box	35
	Controller Properties	36
	Controller Reset	46
	5570 Controllers	46
	5580 Controllers	46
	Memory Card Behavior	47
	Communication Options	48
	Communication Throughput	49
	Download the Program to the Controller	50

**Replacement Considerations
with
ControlLogix 5590 Systems**

Project Size 50
 Build Button 50
 Downloading Workflow Change 51
 Upload Fidelity Change 51
 Thermal Monitoring and Thermal Fault Behavior 51

Chapter 3

Minimum Requirements 54
 ControlLogix Controllers Minimum Requirements 54
 GuardLogix Controllers Minimum Requirements 54
 Product Comparison 55
 ControlLogix 5580 and ControlLogix 5590 Controllers 55
 GuardLogix 5580 and Safety-enabled ControlLogix 5590 Controllers 57
 Controller Dimensions 59
 ControlLogix 5580 Dimensions 59
 GuardLogix 5580 Dimensions 59
 ControlLogix 5590 Dimensions 60
 Connectors and Status Indicators 61
 Configure the Controller 63
 New Project Dialog Box 63
 Controller Properties 64
 Memory Card Behavior 75
 Communication Options 76
 Communication Throughput 76
 EtherNet/IP Modes 77
 Dual-IP Mode 77
 Linear/DLR Mode 78
 Thermal Monitoring and Thermal Fault Behavior 79

**Replacement Considerations
with CompactLogix and
Compact GuardLogix Systems**

Chapter 4

Minimum Requirements 82
 CompactLogix Controllers Minimum Requirements 82
 Compact GuardLogix Controllers Minimum Requirements 82
 Product Comparison 82
 CompactLogix Controllers 82
 Compact GuardLogix Controllers 84
 Controller Spacing 86
 CompactLogix 5370 L3 and Compact GuardLogix 5370 L3 Spacing 86
 CompactLogix 5380 Spacing 86
 Compact GuardLogix 5380 Spacing 87
 Controller Dimensions 87
 CompactLogix 5370 L3 Dimensions 87
 CompactLogix 5380 Dimensions 88
 Compact GuardLogix 5370 Dimensions 88
 Compact GuardLogix 5380 SIL 2 Controller Dimensions 89
 Compact GuardLogix 5380 SIL 3 Controller Dimensions 89
 Connectors and Status Indicators 90
 Power the Controller 93
 Project Size 93

Configure the Controller	94
Connections Overview	94
Nodes on an EtherNet/IP Network	94
New Project Dialog Box	95
Controller Properties	96
Controller Reset Button	102
SD Card Behavior	103
Communication Options.....	104
Communication Throughput	105
EtherNet/IP Modes	106
Dual-IP Mode	106
Linear/DLR Mode.....	107
Use Compact I/O and Compact 5000 I/O Modules in CompactLogix Systems	108
CompactLogix 5370 L3 System	109
CompactLogix 5380 System	109
Local I/O Module Performance	110
Event Task Triggers	111
Scheduled Outputs	111
Download the Program to the Controller.....	112
Build Button.....	112
Downloading Workflow Change.....	112
Upload Fidelity Change.....	112
Thermal Monitoring and Thermal Fault Behavior	113

Chapter 5

Replacement Considerations with Safety Applications

Perform Risk Assessment	115
Firmware Upgrade Guidelines for Safety Controllers.....	115
Applications with	
1734-AENTR Series A Modules	117
Safety Signature	117
GSV of Safety Attributes.....	117
Safety Signature in Run Mode	118
Safety Level Configuration	118
Safety Network Number.....	119
Produce/Consume Safety Tags.....	120
Safety Application Conversion	120
Compact GuardLogix 5380 Controllers.....	120
GuardLogix 5580 Controllers.....	121
Exporting and importing Safety Add-on Instructions.....	121
Convert a Safety Application	121
Replace the Producer Controller.....	127

Chapter 6

Replacement Considerations with High Availability Systems

Overview	129
Product Comparison Redundancy	130
Product Comparison Logix SIS	131
Front Port Crossload	132
Data Transfer	132

Standard Application Conversion

Chapter 7

Converting Logix Designer Projects	133
Produce and Consume Tags	134
RPI of Multicast Tags	134
Data Structures	134
Late Binding of I/O Data	139
Standard Native I/O Data Types and Tags	139
I/O Data Manipulation	139
Controller Memory Usage	140
Unconnected Message Buffers	140
Motion Applications	141
ControlLogix 5590, ControlLogix 5580, and GuardLogix 5580 Controllers	141
CompactLogix 5380 and Compact GuardLogix 5380 Controllers	142
Axis Position References in Move Instructions	142
Pending Edits	143
AXIS_CIP_Drive Data Type	143

Chapter 8

Instruction Execution

Math-related Instructions	145
TRN Instruction Changes	146
Improved Math Instruction Accuracy	146
SQR/SQRT Adjustment	147
X Mod 0	148
AND, NOT, OR, and XOR Support for REAL	148
Floating Point Literals	150
XPY Instruction	151
0.0 div 0.0	152
Structural Changes to Execution	152
JSR Nesting Level Limit	153
Max Number of Inputs or Outputs for a Program JSR/RET	154
Max Number of InOut Parameters for an Add-On Instruction	155
Jump to Label Must Be Present	156
MCR Placement	157
Data Alignment and Memory Allocation Rules for User-defined Data Types (UDTs) That Contain LINTs	158
SFC Reset Affect on Active Step	159
Instruction Error and Fault Changes	160
Subscript Expressions	160
TRN Operator and Math Status Flags	161
Math Status Flags are Valid Only in One Rung	162
AVE and STD Instruction Accuracy	163
BTD, FAL, FSC, and CMP No Longer Generate Math Status	164
Math Status Flags Not Permitted in Structured Text	165
Minor Fault on Overflow	166
Manually Set Math Overflow	167
TOD Instruction Flags and Math Status Flags	168
Add-On Instructions Do Not Propagate Math Status Flags	168
Subroutines Do Not Affect Math Status Flags	169
Carry Flag	170

Store NAN in an Integer	171
Compare NAN Values	171
Operand Changes	172
Converting +/- Infinity	172
Copy/File Instructions	173
COP and CPS Into Structures	173
JSR and RET Parameters Passing Into Structures	174
JSR Passing Atomic Data Type into an Array or Structure.	175
Instructions That Operate On Arrays	177
GSV/SSV Instructions	178
MCT/MCTP Instructions	178

Chapter 9

Diagnostics and Status

Indicators with ControlLogix Systems

Controller Status Display and Indicators	179
4-Character Display	179
Status Indicators	181
MOD Status Indicator - 5590 Controllers	181
OK Status Indicator - 5580 and 5570 Controllers	181
Ethernet Indicators	182
Controller Web Pages	183
Home Web Page	184
Faults Web Page	186
Tasks Web Page	187
Diagnostics Web Pages	188
Ethernet Port Web Page - 5590 Controllers Only.	189
Advanced Diagnostics Web Pages	190
Advanced Diagnostics - Ethernet Ports Web Pages - 5590 Controllers Only.	191
Browse Chassis Web Page	192

Chapter 10

Diagnostics and Status

Indicators with CompactLogix Systems

Controller Status Display and Indicators	194
4-Character Display	194
Controller Status Indicators	196
EtherNet/IP Status Indicators	196
Power Status Indicators	197
Controller Web Pages	198
Differences Between 5380 and 5370 Controllers	198
EtherNet/IP Mode Affect on 5380 Controller Web Pages	198
Home Web Page	199
Tasks Web Page	200
Diagnostics Web Pages	201
Ethernet Port A1/A2 Web Pages	202
Advanced Diagnostics Web Pages	203
Browse Chassis Web Page	204

Appendix A

Replacement Considerations for 1768-L4 and 1769-L3 Controllers

Minimum Requirements	205
CompactLogix Controllers Minimum Requirements	205

Compact GuardLogix Controllers Minimum Requirements	205
Product Comparison	206
CompactLogix Controllers Product Comparison	206
Compact GuardLogix Controllers Product Comparison	209
Controller Spacing	211
CompactLogix 1769-L3 Spacing	211
CompactLogix 1768-L4 and Compact GuardLogix 1768-L4 Spacing	211
CompactLogix 5380 Spacing	212
Compact GuardLogix 5380 Spacing	212
Controller Dimensions	213
CompactLogix 1769-L3 Dimensions	213
CompactLogix 1768-L4 Dimensions	213
CompactLogix 5380 Dimensions	214
Compact GuardLogix 1768-L4 Dimensions	214
Compact GuardLogix 5380 SIL 2 Controller Dimensions	215
Connectors and Status Indicators	215
Power the Controller	218
Nonvolatile Memory	219
Communication Options	220
EtherNet/IP Communication	220
ControlNet Communication	221
Serial Communication	221

Migrate a PIDE Instruction to a PPID Instruction

Appendix B

Equivalent Input Parameters	224
Alternative Input Parameters	235
Equivalent or Alternative Input Parameters	236
No Equivalent Input Parameters	238
Equivalent Output Parameters	240
Alternative Output Parameters	245
No Equivalent Output Parameters	247
Differences In Alarming	248
Timing Mode Parameters That Are Not Available In PPID Instruction	253
Zero Crossing Deadband and Process Variable Deviation Deadband	254
Control Variable Rate of Change Limiting	256
Control Variable Manual Limiting	258
Differences In Control Variable Related Inputs	259
Differences in Override	259
Differences in Operator Mode	262
Differences in Cascade	265
Differences in PV Clamping	265
Differences in Control Variable Scaling and Limits Configuration	266
Autotuning is Not Available In the PPID Instruction	266

History of Changes

Appendix C

Change Log	267
------------------	-----

Index	269
--------------------	-----

About This Manual

This manual is intended to offer guidelines when you replace the following:

- ControlLogix® 5580 controller with a ControlLogix 5590 controller
- ControlLogix 5580 redundancy with ControlLogix 5590 redundancy
- Logix SIS update: GuardLogix® 5580 redundancy with safety-enabled ControlLogix 5590 controllers (5590 controllers are safety-enabled by default)
- ControlLogix 5570 controller with a ControlLogix 5580 controller
- Guidelines that reference a ControlLogix 5570 controller also apply to a ControlLogix 5560 controller
- ControlLogix® 5570 redundancy with a ControlLogix 5580 redundancy
- GuardLogix® 5560 or GuardLogix 5570 controller with a GuardLogix 5580 controller
- CompactLogix® 5370 L3 controller with a CompactLogix 5380 controller
- Compact GuardLogix 5370 L3 controller with a Compact GuardLogix 5380 SIL 2 or SIL 3 controller
- CompactLogix 1769-L3 controller with a CompactLogix 5380 controller
- CompactLogix 1768-L4 controller with a CompactLogix 5380 controller
- Compact GuardLogix 1768-L4 controller with a Compact GuardLogix 5380 controller

Rockwell Automation recognizes that some of the terms that are currently used in our industry and in this publication are not in alignment with the movement toward inclusive language in technology. We are proactively collaborating with industry peers to find alternatives to such terms and making changes to our products and content. Please excuse the use of such terms in our content while we implement these changes.

Download Firmware, AOP, EDS, and Other Files

Download firmware, associated files (such as AOP, EDS, and DTM), and access product release notes from the Product Compatibility and Download Center at rok.auto/pcdc.

Summary of Changes

This manual contains new and updated information. This list includes substantive updates only and is not intended to reflect all changes. Change bars identify changes in the manual.

Topic	Page
Added information to the list of controller replacements	9
Added to the Additional Resources list	11
Added a description of ControlLogix 5590 controllers	14
Updates to the controller Considerations section	16
Added ControlLogix 5590 controllers to the Features on ControlLogix Controllers section	17
Updated information for CompactLogix 5380 and Compact GuardLogix 5380 controller specifications	22
Added content to the initial descriptions of ControlLogix 5580 and GuardLogix 5580 systems description	23
Updated information in the ControlLogix 5570 and ControlLogix 5580 controllers product comparison table	24
Updated information in the GuardLogix 5570 and GuardLogix 5580 controllers product comparison table	26
Updated the differences between Controller Properties tabs between ControlLogix 5570 and ControlLogix 5580 controllers, and GuardLogix 5570 and GuardLogix 5580 controllers	36
Added information to the Advanced tab in the Controller Properties dialog box description for ControlLogix 5580 controllers	37
Updated the screenshot of the Advanced tab in the Controller Properties dialog box for ControlLogix 5580 controllers	37
Updated the screenshot of the Capacity tab in the Controller Properties dialog box for ControlLogix 5580 controllers	39
Updated the information about the Safety tab in the Controller Properties dialog box for ControlLogix 5570 and 5580 controllers	44
Added information about the OPC UA tab in the Controller Properties dialog box for ControlLogix 5580 controllers	45
Added Chapter 3, Replacement Considerations with ControlLogix 5590 Systems, to describe difference between ControlLogix 5580 systems and ControlLogix 5590 systems	53
Updated information in the CompactLogix Controllers product comparison table	82
Added information about Safety Signature in Run Mode	118
Added information about Safety Level Configuration	118
Added information about Safety Network Number with ControlLogix 5590 controllers	119
Updated the Redundancy chapter to add Logix SIS and redundancy systems information with ControlLogix 5590 controller information	129
Added information about Front Port Crossload with ControlLogix 5590 controllers	132
Added information to the Data Transfer section	132
Added information to section Unconnected Message Buffers	140
Added information to section Motion Applications	141
Added information to the 4-character display message list	180
Added a new message for the 4-character display on ControlLogix 5590 controllers	180
Updated information about the MOD status indicator on ControlLogix 5590 controllers	181
Updated information about the OK status indicator on ControlLogix 5570 and 5580 controllers	181
Added information about ControlLogix 5590 controllers to the Controller Web Pages section	183
Added information about the ControlLogix 5590 controllers' Home web pages	185
Added information to the Diagnostics web page description	188
Added information about the ControlLogix 5590 controllers' Diagnostics web pages	188
Added information about the ControlLogix 5590 controllers' Ethernet Port web page	189
Added information about the ControlLogix 5590 controllers' Advanced Diagnostics web page	190
Added information about the ControlLogix 5590 controllers' Advanced Diagnostics - Ethernet Ports web pages	191
Added information on how to migrate a PIDE instruction to a PPID instruction	223
Added a History of Changes	267

Additional Resources

These documents contain additional information concerning related products from Rockwell Automation. You can view or download publications at rok.auto/literature.

Resource	Description
EtherNet/IP Network Devices User Manual, publication ENET-UM006 ControlLogix EtherNet/IP Network Devices User Manual, publication 1756-UM004 ControlNet Network Configuration User Manual, publication CNET-UM001 ControlNet to EtherNet/IP Migration Reference Manual, publication CNET-RM001 DeviceNet Network Configuration User Manual, publication DNET-UM004	EtherNet/IP™, ControlNet®, and DeviceNet® Networks
Logix 5000 Controllers Common Procedures Programming Manual, publication 1756-PM001 Logix Controllers Instructions Reference Manual, publication 1756-RM009 Logix 5000 Controllers Advanced Process Control and Drives Instructions Reference Manual, publication 1756-RM006 Logix 5000 Controllers Motion Instructions Reference Manual, publication MOTION-RM002 Logix 5000 Controllers Import/Export Reference Manual, publication 1756-RM084	Logix 5000® Software and Programming
1756 ControlLogix Controllers Technical Data, publication 1756-TD001 ControlLogix 5590 Controllers Installation Instructions, publication 1756-IN900 ControlLogix 5590 Controller User Manual, publication 1756-UM900 ControlLogix 5580 Controllers Installation Instructions, publication 1756-IN043 Logix SIS Reference Manual, publication 1756-RM015 ControlLogix 5590 High Availability Systems User Manual, publication 1756-UM901 ControlLogix 5580 and GuardLogix 5580 Controllers User Manual, publication 1756-UM543 ControlLogix 5580 Redundant Controller User Manual, publication 1756-UM015 ControlLogix 5570 Redundancy User Manual, publication 1756-UM535 High Availability System Reference Manual, publication HIGHAV-RM002 ControlLogix Power Supply Installation Instructions, publication 1756-IN619 ControlLogix Redundant Power Supply Installation Instructions, publication 1756-IN620 ControlLogix Chassis Installation Instructions, publication 1756-IN621 1756 ControlLogix Chassis Specifications Technical Data, publication 1756-TD006	ControlLogix and GuardLogix, Controllers, Chassis, and Power Supply
CompactLogix 5380 Controller Specifications Technical Data, publication 5069-TD002 CompactLogix 5380 Controllers Installation Instructions, publication 5069-IN013 CompactLogix 5380 and Compact GuardLogix 5380 Controllers User Manual, publication 5069-UM001 CompactLogix 5370 Controllers User Manual, publication 1769-UM021 CompactLogix 5370 L3 Controllers Quick Start, publication IASIMP-QS023 1768 CompactLogix Controller User Manual, publication 1768-UM001 Compact GuardLogix User Controllers Manual, publication 1768-UM002	CompactLogix and Compact GuardLogix Controllers
Industrial Automation Wiring and Grounding Guidelines, publication 1770-4.1	Provides general guidelines for installing a Rockwell Automation industrial system.
Product Certifications website, rok.auto/certifications .	Provides declarations of conformity, certificates, and other certification details.
Technical Documentation Center website, rok.auto/techdocs .	Quickly access and download technical specifications, installation instructions, and user manuals.
Product Compatibility and Download Center (PCDC) website, rok.auto/pcdc	Download firmware, associated files (such as AOP, EDS, and DTM), and access product release notes.

Notes:

Before You Begin a Migration

This publication features these controllers, and where applicable, the controllers are known as:

Controller Family	Includes these controllers
5590 controllers	ControlLogix® 5590 controllers
5580 controllers	ControlLogix 5580 and GuardLogix® 5580 controllers
5380 controllers	CompactLogix® 5380, Compact GuardLogix 5380 SIL 2, and Compact GuardLogix 5380 SIL 3 controllers
5570 controllers	ControlLogix 5570 and GuardLogix 5570 controllers
5370 controllers	CompactLogix 5370 and Compact GuardLogix 5370 controllers
1769-L3 controllers	CompactLogix 1769-L31, 1769-L32C, 1769-L32E, 1769-L35CR, 1769-L35E controllers
1768-L4 controllers	1768 CompactLogix and 1768 Compact GuardLogix L4 controllers

This publication provides a reference to controller capabilities and how:

- 5590 controller capabilities differ from the 5580/5570 controllers.
- 5580 controller capabilities differ from 5570 controllers.
- 5380 controller capabilities differ from the 5370 controllers.

IMPORTANT

Any user or third-party developer of communications software to a ControlLogix or CompactLogix controller must fully follow the Logix 5000® Data Access Programming Manual, [1756-PM020](#).

Beginning with Logix controller families 5380 and 5580, the full implementation and enforcement of the CIP™ specification standard for ANSI Extended Symbolic Ox91 is required, as documented in the above referenced publication and the ODVA CIP specification.

Any custom or third-party communications software, which previously only supported ANSI Extended Symbolic Ox61, must be updated to communicate to these new controllers.

Previous Logix controller families CompactLogix L1, L2, L3, 5370 and ControlLogix 5550, 5560, 5570 continue to support both the Ox91 CIP Standard and the older, no longer in use, Ox61.

ControlLogix 5590 Controllers

All 5590 controllers support the following applications:

- Standard
- Safety
- High availability (redundancy and Logix SIS applications)

Select catalogs also offer Process capabilities in addition to the features above.

Supporting the Integrated Architecture® and FactoryTalk® ecosystem, the 5590 controllers are designed for faster performance, enhanced capacity and optimized productivity.

IMPORTANT ControlLogix 5590 controllers require a NEMA 1 or equivalent, windowless, metal enclosure.

Enhanced Performance and Capacity

5590 controllers have enhanced performance and capacity compared to all previous generation controllers. Enhancements include:

- Faster scan times for both non-redundant and high availability (HA) applications.
- All 5590 controllers include both standard and safety memory.
- There are increased memory offerings. As a result, 5590 controllers offer larger and smaller memory options to meet your specific needs.
- Second Ethernet port for EtherNet/IP™ network connection.
- Increased EtherNet/IP node limits.
- Improved performance in Integrated Motion over EtherNet/IP networks.
- Improved redundancy performance with the new EtherNet/IP front port crossload functionality.
- Designed and built for use in harsh environments.

Security Certification

5590 controllers are CIP Security-capable and are IEC-62443-4-2 SL 1 security certified.

EtherNet/IP Network Functionality

5590 controllers have two 1 Gb, RJ45 network ports. You no longer need a 1756 ControlLogix EtherNet/IP communication module in the same chassis or a 1783-ETAP to connect the controllers to DLR or Linear networks.

Additionally, Dual-IP mode lets you simultaneously connect 5590 controllers to enterprise-level networks via one port 1 and to device-level networks via port 2.

IMPORTANT When Redundancy is enabled on a 5590 controller, the front port is disabled except for front port crossload.

Safety Applications

ControlLogix 5590 controllers are IEC 61508 SIL 2/PLd-certified. They are also IEC 61508 SIL 3/PLe-certified in the following applications:

- Logix SIS applications
- With a ControlLogix 5590 safety partner in non-Logix SIS safety applications

IMPORTANT ControlLogix 5590 controllers are safety-enabled by default. If you don't want to use safety features, you can disable safety in the Studio 5000 Logix Designer® software project Controller Properties dialog box but are not required to do so.

Comparisons to GuardLogix 5580 controllers throughout this publication represent the ControlLogix 5590 controllers' functionality and performance when they are safety-enabled.

Harsh Environments

ControlLogix-XT™ 5590 controllers are designed for use harsh environments. You use 5590 controllers with XT in the catalog number in these environments.

Process Applications

ControlLogix-XT 5590 Process controllers let you design ControlLogix systems that focus on plant-wide process control. You use 5590 controllers with a P in the catalog number for process control.

Migrate to 5590 Controller Applications

You can migrate from any previous ControlLogix controller family to 5590 controllers.

However, there are differences between 5570 controllers and 5580 controllers and differences between 5580 controllers and 5590 controllers that you should be aware of before migrating.

Those differences are described in the Replacement Considerations chapters later in this publication. We strongly recommend that you complete the following path to convert to 5590 controllers.

Table 1 - Replacement Considerations Chapters to Read

Controller Application	Target Migration Application	Relevant Replacement Considerations Chapters
5570 controllers	5590 controllers	Chapter 2 Chapter 3
5580 controllers	5590 controllers	Chapter 3
GuardLogix 5570 controllers	5590 controllers (safety-enabled)	Chapter 2 Chapter 3 Chapter 5
GuardLogix 5580 controllers	5590 controllers (safety-enabled)	Chapter 3 Chapter 5
5570 controllers redundancy	5590 controller redundancy	Chapter 2 Chapter 3 Chapter 6
5580 controller redundancy	5590 controller redundancy	Chapter 3 Chapter 6
5580 controller Logix SIS	5590 controller Logix SIS	Chapter 3 Chapter 6

Considerations

Throughout this manual, the following apply:

- Catalog numbers followed by a "K" indicate a conformal coating option.
- Guidelines that reference a ControlLogix 5570 controller also apply to a ControlLogix 5560 controller.
- There are references to controller project versions. Controller project versions 20 or earlier are created in RSLogix 5000® software. Controller project versions 21 or later are created in the Studio 5000 Logix Designer® environment, referred to as the Logix Designer application throughout this publication.
- Not all controllers are available with all versions of RSLogix 5000 software or the Logix Designer application.

For example, CompactLogix 5370 L3 controllers are available in RSLogix 5000 software, version 20 and the Logix Designer application, version 21 or later.

- Unless otherwise indicated, the graphics that are used throughout manual are the same for 5380 and 5580 controllers.
- ControlLogix 5580 and GuardLogix 5580 controllers use Secure Digital (SD) cards and ControlLogix 5590 controllers use microSD™ cards. Throughout this manual, the term memory card means either type. Where necessary, the card type is specified.

For more information on what memory cards the controllers support, see the ControlLogix and GuardLogix Controller Specification Technical Data, publication [1756-TD001](#).

Product compatibility information and release notes are available online within the Product Compatibility and Download Center (PCDC) website, rok.auto/pcdc

Features on ControlLogix Controllers

The following table indicates the Studio 5000 Logix Designer environment version in which product features are available on 5570, 5580 and 5590 controllers.

Table 2 - Features - ControlLogix Controllers Features

Feature	Controllers		
	ControlLogix 5570 GuardLogix 5570	ControlLogix 5580 GuardLogix 5580	ControlLogix 5590
Hardware support	<p>New controllers in version 18:</p> <ul style="list-style-type: none"> • 1756-L73 • 1756-L75 <p>New controllers in version 19:</p> <ul style="list-style-type: none"> • 1756-L72 • 1756-L74 <p>New controllers in version 20.011:</p> <ul style="list-style-type: none"> • 1756-L71 • 1756-L73XT • 1756-L72S • 1756-L73S, 1756-L73SXT • 1756-L7SP <p>New controller in version 20.12: 1756-L71S</p>	<p>New controllers in version 28:</p> <ul style="list-style-type: none"> • 1756-L83E • 1756-L85E <p>New controllers in version 29:</p> <ul style="list-style-type: none"> • 1756-L81E • 1756-L82E • 1756-L84E <p>New controllers in version 31:</p> <ul style="list-style-type: none"> • 1756-L81ES • 1756-L82ES • 1756-L83ES • 1756-L84ES • 1756-L8SP <p>New controllers in version 33:</p> <ul style="list-style-type: none"> • 1756-L81E-NSE, 1756-L82E-NSE, 1756-L83E-NSE, 1756-L84E-NSE, 1756-L85E-NSE • 1756-L81EXT, 1756-L82EXT, 1756-L83EXT, 1756-L84EXT, 1756-L85EXT • 1756-L81EP/1756-L81EPXT, 1756-L83EP/1756-L83EPXT, 1756-L85EP/1756-L85EPXT <p>New controllers in version 35:</p> <ul style="list-style-type: none"> • 1756-L81EXTS/1756-L81ESXT • 1756-L82EXTS/1756-L82ESXT • 1756-L83EXTS/1756-L83ESXT • 1756-L84EXTS/1756-L84ESXT • 1756-L8XTSP/1756-L8SPXT 	<p>New controllers in version 38:</p> <ul style="list-style-type: none"> • 1756-L902TS, 1756-L905TS, 1756-L908TS, 1756-L915TS, 1756-L925TS, 1756-L950TS, 1756-L980TS, 1756-L9SP • 1756-L902TSXT, 1756-L905TSXT, 1756-L908TSXT, 1756-L915TSXT, 1756-L925TSXT, 1756-L950TSXT, 1756-L980TSXT, 1756-L9SPXT • 1756-L905TPSXT, 1756-L915TPSXT, 1756-L950TPSXT, 1756-L980TPSXT, 1756-L9SPXT
1 Gbps Ethernet port	Not applicable	Single embedded Ethernet port that supports up to 1 Gbps communication rate	Dual, embedded Ethernet ports that each support up to 1 Gbps communication rate
EtherNet/IP™ modes: <ul style="list-style-type: none"> • Dual-IP mode • DLR/Linear mode 	Not applicable	Not supported	Version 38 or later support Dual-IP mode and DLR/Linear mode
Instruction-based alarms (ALMA, ALMD)	All versions	Version 29 or later	Version 38 or later
Tag-based Alarms	Not applicable	Version 31 or later	Version 38 or later
Integrated Motion on EtherNet/IP	All versions	Version 28 or later	Version 38 or later
SERCOS motion	All versions	Version 31 or later	Version 38 or later
Analog motion	All versions	Version 31 or later	Version 38 or later

Table 2 - Features - ControlLogix Controllers Features

Feature	Controllers		
	ControlLogix 5570 GuardLogix 5570	ControlLogix 5580 GuardLogix 5580	ControlLogix 5590
Integrated safety SIL 2/PLd	<p>Version 20 or later for ControlLogix 5570 controllers only, along with components of the ControlLogix system that are type-approved and certified for use in SIL 2 applications, according to IEC 61508. ⁽¹⁾ For more information, see the Using ControlLogix in SIL 2 Applications Safety Reference Manual, publication 1756-RM001.</p> <p>Version 28 or later with these GuardLogix 5570 controllers and safety partner:</p> <ul style="list-style-type: none"> • 1756-L7IS and 1756-L7SP • 1756-L72S and 1756-L7SP • 1756-L73S and 1756-L7SP 	<p>Version 31 or later with these GuardLogix 5580 controllers:</p> <ul style="list-style-type: none"> • 1756-L81ES • 1756-L82ES • 1756-L83ES • 1756-L84ES <p>Achieve SIL 2/PLd with the use of a primary safety controller, the safety task, and safety I/O.</p> <p>Version 35 or later with these GuardLogix-XT™ 5580 controllers:</p> <ul style="list-style-type: none"> • 1756-L81EXTS • 1756-L82EXTS • 1756-L83EXTS • 1756-L84EXTS <p>Achieve SIL 2/PLd with the use of a primary safety controller, the safety task, and safety I/O.</p>	Version 38 or later
Integrated safety SIL 3/PLe	<p>Version 28 or later with these GuardLogix 5570 controllers and safety partner:</p> <ul style="list-style-type: none"> • 1756-L7IS and 1756-L7SP • 1756-L72S and 1756-L7SP • 1756-L73S and 1756-L7SP 	<p>Version 31 or later with these GuardLogix 5580 controllers and safety partner:</p> <ul style="list-style-type: none"> • 1756-L81ES • 1756-L82ES • 1756-L83ES • 1756-L84ES • 1756-L8SP <p>Version 35 or later with these GuardLogix XT 5580 controllers:</p> <ul style="list-style-type: none"> • 1756-L81EXTS • 1756-L82EXTS • 1756-L83EXTS • 1756-L84EXTS • 1756-L8XTSP 	Version 38 or later when used with a safety partner in non-redundant safety applications or without the partner in Logix SIS applications
PanelView™ 5000 graphic terminal support	Version 27 or later	Version 29 or later	Version 38 or later

Table 2 - Features - ControlLogix Controllers Features

Feature	Controllers		
	ControlLogix 5570 GuardLogix 5570	ControlLogix 5580 GuardLogix 5580	ControlLogix 5590
High Availability Systems			
Redundancy	ControlLogix 5570 controllers - Versions 19, 20, 24, and 30 or later	Version 33 or later for ControlLogix 5580 controllers ⁽²⁾	Version 38 or later
Logix SIS	Not supported	Version 37 or later for GuardLogix 5580 controllers	Version 38 or later
Front Port Crossload - Redundancy and Logix SIS	Not supported	Not supported	Version 38 or later
PhaseManager™	All versions	Version 32 or later	Version 38 or later
SequenceManager™	Version 28 or later	Version 35 or later ⁽³⁾	Version 38 or later
Drive-based CIP Safety™ stopping functions (STO ⁽⁴⁾ , monitored/timed SS1)	Version 30 or later	Version 31 or later	Version 38 or later
Controller-based CIP Safety stopping and monitoring functions (SS1, SS2, SOS, SLS, SLP, SDI)	Not applicable	Version 31 or later	Version 38 or later
Secured Data Exchange	Version 30 or later	Version 32 or later	Version 38 or later
Controller-based Audit Log	Version 30 or later	Version 32 or later	Version 38 or later
Controller Change Detection	Version 30 or later	Version 32 or later	Version 38 or later
Emulate	All versions	—	—
FactoryTalk® Logix Echo	Not supported	Version 33 or later for ControlLogix 5580 controllers Version 35 or later for GuardLogix 5580 controllers	Version 38 or later

(1) ControlLogix 5580 or 5590 controllers do not support this type of SIL 2 application.

(2) ControlLogix 5590 and ControlLogix 5580 controllers who are enabled for redundancy experience no reduction in memory from a standard use ControlLogix 5590 and ControlLogix 5580 controller, respectively.

(3) For ControlLogix-XT 5590 Process controllers, ControlLogix 5580 Process controllers and CompactLogix 5380 Process controllers only.

(4) Only the safety-enabled ControlLogix 5590, GuardLogix 5570, GuardLogix 5580, Compact GuardLogix 5370, and Compact GuardLogix 5380 controllers support drive-based CIP Safety.

Features on CompactLogix Controllers

The following table indicates the Studio 5000 Logix Designer environment version in which product features are available on 5380 controllers.

Table 3 - Features - CompactLogix Controllers

Feature	CompactLogix Controllers	
	CompactLogix 5370 L3 Compact GuardLogix 5370 L3	CompactLogix 5380 Compact GuardLogix 5380
Hardware support	<p>New controllers in version 28:</p> <ul style="list-style-type: none"> • 1769-L30ERMS • 1769-L33ERMS • 1769-L36ERMS <p>New controllers in version 31:</p> <ul style="list-style-type: none"> • 1769-L37ERM • 1769-L37ERMS • 1769-L38ERM • 1769-L38ERMS • 1769-L38ERMO • 1769-L38ERMOS 	<p>New controllers in version 28:</p> <ul style="list-style-type: none"> • 5069-L320ER • 5069-L340ERM <p>New controllers in version 29:</p> <ul style="list-style-type: none"> • 5069-L306ER, 5069-L306ERM • 5069-L310ER, 5069-L310ER-NSE, 5069-L310ERM • 5069-L320ERM • 5069-L330ER, 5069-L330ERM • 5069-L340ER • 5069-L350ER <p>New controllers in version 30:</p> <ul style="list-style-type: none"> • 5069-L350ERM • 5069-L380ERM • 5069-L3100ERM <p>New controllers in version 31:</p> <ul style="list-style-type: none"> • 5069-L306ERS2 • 5069-L306ERMS2 • 5069-L310ERS2 • 5069-L310ERMS2 • 5069-L320ERS2 • 5069-L320ERMS2 • 5069-L330ERS2 • 5069-L330ERMS2 • 5069-L340ERS2 • 5069-L340ERMS2 • 5069-L350ERS2 • 5069-L350ERMS2 • 5069-L380ERS2 • 5069-L380ERMS2 • 5069-L3100ERS2 • 5069-L3100ERMS2 <p>New controllers in version 32:</p> <ul style="list-style-type: none"> • 5069-L306ERMS3 • 5069-L310ERMS3 • 5069-L320ERMS3 • 5069-L330ERMS3 • 5069-L340ERMS3 • 5069-L350ERMS3 • 5069-L380ERMS3 • 5069-L3100ERMS3 <p>New controllers in version 33:</p> <ul style="list-style-type: none"> • 5069-L320ERP • 5069-L340ERP <p>No new controllers in versions 34 or later</p>

Table 3 - Features - CompactLogix Controllers

Feature	CompactLogix Controllers	
	CompactLogix 5370 L3 Compact GuardLogix 5370 L3	CompactLogix 5380 Compact GuardLogix 5380
1 Gbps Ethernet port	Not supported	Dual, embedded Ethernet ports that each support up to 1 Gbps communication rate
EtherNet/IP™ modes: <ul style="list-style-type: none"> Dual-IP mode DLR/Linear mode 	DLR/Linear mode in all versions that support CompactLogix 5370 L3 controllers	CompactLogix 5380 Controllers Version 28 or later - DLR/Linear mode CompactLogix 5380 Controllers Version 29 or later - Dual-IP mode and DLR/Linear Compact GuardLogix 5380 Controllers Version 31 or later - Dual-IP mode and DLR/Linear
Instruction-based alarms (ALMA, ALMD)	All versions	Version 29 or later
Tag-based Alarms	Not applicable	Version 31 or later
Integrated Motion on EtherNet/IP	All versions ⁽¹⁾	Version 28 or later ⁽¹⁾
SERCOS motion	Not supported	Not supported
Analog motion	Not supported	Not supported
Integrated safety SIL 2/PLd	Not supported	Version 31 or later with these Compact GuardLogix 5380 controllers: <ul style="list-style-type: none"> 5069-L306ERS2 5069-L306ERMS2 5069-L310ERS2 5069-L310ERMS2 5069-L320ERS2 5069-L320ERMS2 5069-L330ERS2 5069-L330ERMS2 5069-L340ERS2 5069-L340ERMS2 5069-L350ERS2 5069-L350ERMS2 5069-L380ERS2 5069-L380ERMS2 5069-L3100ERS2 5069-L3100ERMS2 Achieve SIL 2/PLd with the use of the SIL2/PLd capable safety controller, the safety task, and safety I/O.
Integrated safety SIL 3/PLe	Version 28 or later with these Compact GuardLogix 5370 L3 controllers: <ul style="list-style-type: none"> 1769-L30ERMS 1769-L33ERMS 1769-L36ERMS 1769-L36ERMOS 1769-L37ERMS 1769-L37ERMOS 1769-L38ERMS 1769-L38ERMOS 	Version 32 or later with these Compact GuardLogix 5380 controllers: <ul style="list-style-type: none"> 5069-L306ERMS3 5069-L310ERMS3 5069-L320ERMS3 5069-L330ERMS3 5069-L340ERMS3 5069-L350ERMS3 5069-L380ERMS3 5069-L3100ERMS3 Achieve SIL 3/PLe with the use of the SIL3/PLe capable safety controller, the safety task, and safety I/O.

Table 3 - Features - CompactLogix Controllers

Feature	CompactLogix Controllers	
	CompactLogix 5370 L3 Compact GuardLogix 5370 L3	CompactLogix 5380 Compact GuardLogix 5380
PanelView™ 5000 graphic terminal support	Version 27 or later	Version 29 or later
Redundancy	Not supported	Not supported
PhaseManager™	All versions	Version 32 or later
SequenceManager™	Version 28 or later	Version 35 or later ⁽³⁾
Drive-based CIP Safety™ stopping functions (STO ⁽²⁾ , monitored/timed SSI)	Version 30 or later	Version 31 or later
Controller-based CIP Safety stopping and monitoring functions (SS1, SS2, SOS, SLS, SLP, SDI)	Not applicable	Version 31 or later
Secured Data Exchange	Version 30 or later	Version 32 or later
Controller-based Audit Log	Version 30 or later	Version 32 or later
Controller Change Detection	Version 30 or later	Version 32 or later
Emulate	All versions	—
FactoryTalk® Logix Echo	Not supported	CompactLogix 5380 - Version 35 or later Compact GuardLogix 5380 - Version 36 and later

(1) Not all CompactLogix 5370 L3 or CompactLogix 5380 controllers support Integrated Motion on an EtherNet/IP network.
 (2) Only the safety-enabled ControlLogix 5590, GuardLogix 5570, GuardLogix 5580, Compact GuardLogix 5370, and Compact GuardLogix 5380 controllers support the CIP Safety protocol that is needed for the Safe Torque Off (STO) function.

Integrated Architecture Tools

The Integrated Architecture® system can help you plan and configure a system, and migrate system architectures. For more information, go to [Product Selection and Configuration](#) on the Rockwell Automation website.

Migration Services

Rockwell Automation can help you in the following ways:

- To get the most out of your current equipment.
- To determine your next steps.
- To plan for the transition to newer technology.

You can migrate all at once or use our unique, phased approach. The phased approach helps you minimize the costs, risks, and complexities that are present when you manage legacy products and systems. Regardless of the migration approach that you take, Rockwell Automation has the tools and the experience to guide you through the transition.

For more information, see Migration Solutions Brochure, publication [MIGRAT-BRO02](#).

Replacement Considerations with ControlLogix 5580 and GuardLogix 5580 Systems

This chapter describes features and functions that are associated with the ControlLogix® 5580 and GuardLogix® 5580 controllers.

This chapter features these controllers, and where applicable, the controllers are known as:

Controller Family	Includes these controllers
5580 controllers	ControlLogix 5580 and GuardLogix 5580 controllers
5570 controllers	ControlLogix 5570 and GuardLogix 5570 controllers

It is not an exhaustive list of the features and functions available with the controllers.

- Embedded 10/100/1000 Mbps Ethernet port
- Higher performance and capacity including:
 - Motion Processing: 256 total axes
 - Total I/O packets processing: 128,000 pps
 - 320 unconnected message buffers
 - 256 simultaneous cached message instructions in the running state
 - Support for up to 300 EtherNet/IP™ nodes
- Support for standard and safety I/O modules over an EtherNet/IP™ network
Safety I/O modules are only supported with GuardLogix 5570 and GuardLogix 5580 controllers
- Change Ethernet port speed without a module reset

Minimum Requirements

The 5570 and 5580 controllers have these minimum requirements.

ControlLogix Controllers Minimum Requirements

Requirement, Minimum	ControlLogix 5570 Controller	ControlLogix 5580 Controller
Chassis	1756-A4, 1756-A7, 1756-A10, 1756-A13, 1756-A17 Series A, Series B, and Series C	1756-A4, 1756-A4K, 1756-A7, 1756-A7K, 1756-A10, 1756-A10K, 1756-A13, 1756-A13K, 1756-A17, 1756-A17K 0 °C < Ta < +60 °C (+32 °F < Ta < +140 °F) for Series C Chassis 0 °C < Ta < +50 °C (+32 °F < Ta < +122 °F) for Series B Chassis
Programming Software	Studio 5000 Logix Designer® Application, Version 21.00.00 or later RSLogix 5000® Software Version 20.00.00 or earlier	Studio 5000 Logix Designer Application, Version 28.00.00 or later

GuardLogix Controllers Minimum Requirements

Requirement, Minimum	GuardLogix 5570 Controller	GuardLogix 5580 Controller
Chassis	1756-A4, 1756-A7, 1756-A10, 1756-A13, 1756-A17 Series A, Series B, and Series C	1756-A4, 1756-A4K, 1756-A7, 1756-A7K, 1756-A10, 1756-A10K, 1756-A13, 1756-A13K, 1756-A17, 1756-A17K Operating in SIL 2/PL d Configuration: 0 °C < Ta < +60 °C (+32 °F < Ta < +140 °F) for Series C Chassis 0 °C < Ta < +50 °C (+32 °F < Ta < +122 °F) for Series B Chassis Note: If operating above +55 °C (+131 °F), modules greater than 6.2 W shall not be installed in slots adjacent to the controller. Operating in SIL 3/PL e Configuration: 0 °C < Ta < +60 °C (+32 °F < Ta < +140 °F) for Series C Chassis 0 °C < Ta < +50 °C (+32 °F < Ta < +122 °F) for Series B Chassis
Programming Software	Studio 5000 Logix Designer Application, Version 21.00.00 or later RSLogix 5000 Software Version 20.00.00 or earlier	Studio 5000 Logix Designer Application Version 31.00.00 or later

Product Comparison

This section compares:

- ControlLogix 5580 controllers to ControlLogix 5570 controllers
- GuardLogix 5580 controllers and GuardLogix 5570 controllers

ControlLogix Controllers

The ControlLogix 5580 controllers and ControlLogix 5570 controllers operate similarly, with some differences.

Attribute	ControlLogix 5570 Controller	ControlLogix 5580 Controller
Controller Memory	4...32 MB user memory	<ul style="list-style-type: none"> • 1756-L81E, 1756-L81E-NSE, 1756-L81EXT, 1756-L81EP: 3 MB • 1756-L82E, 1756-L82E-NSE, 1756-L82EXT: 5 MB • 1756-L83E, 1756-L83E-NSE, 1756-L83EXT, 1756-L83EP: 10 MB • 1756-L84E, 1756-L84E-NSE, 1756-L84EXT: 20 MB • 1756-L85E, 1756-L85E-NSE, 1756-L85EXT, 1756-L85EP: 40 MB
I/O Memory	0.98 MB	Not applicable ⁽¹⁾
Remote I/O modules supported	<ul style="list-style-type: none"> • 1794 FLEX™ I/O • 1769 Compact I/O™ • 1756 ControlLogix I/O • 1734 POINT I/O™ • 1732E ArmorBlock® • 1715 Redundant I/O 	<ul style="list-style-type: none"> • 5094 FLEX 5000® I/O⁽²⁾ • 5069 Compact 5000® I/O⁽³⁾ • 5034 PointMax™ I/O⁽⁴⁾ • 5032 ArmorBlock 5000® I/O⁽⁵⁾ • 5015 FLEXHA 5000™ I/O⁽⁵⁾ • 1794 FLEX I/O • 1769 Compact I/O • 1756 ControlLogix I/O • 1734 POINT I/O • 1732E ArmorBlock • 1715 Redundant I/O

Attribute	ControlLogix 5570 Controller	ControlLogix 5580 Controller
Ethernet performance	Not applicable	10/100/1000 Mbps
EtherNet/IP nodes supported, max	Controller connections: a total of 500 connections that are used for Ethernet I/O and Ethernet Messaging.	Count the number of Ethernet nodes included in the I/O configuration section of the Logix Designer application project. For more information, see Nodes on an EtherNet/IP Network on page 33 . Logix Designer application, version 28: <ul style="list-style-type: none"> 1756-L83E: 100 1756-L85E: 300⁽⁶⁾ Logix Designer application, version 29: <ul style="list-style-type: none"> 1756-L81E: 60 1756-L82E: 80 1756-L83E: 100 1756-L84E: 150 1756-L85E: 300⁽⁶⁾ Logix Designer application, version 30 or later: <ul style="list-style-type: none"> 1756-L81E, 1756: 100 1756-L82E: 175 1756-L83E: 250 1756-L84E: 250 1756-L85E: 300⁽⁶⁾ Logix Designer application, version 33 or later: <ul style="list-style-type: none"> 1756-L81E-NSE, 1756-L81EXT, 1756-L81EP: 100 1756-L82E-NSE, 1756-L82EXT: 175 1756-L83E-NSE, 1756-L83EXT, 1756-L83EP: 250 1756-L84E-NSE, 1756-L84EXT: 250 1756-L85E-NSE, 1756-L85EXT, 1756-L85EP: 300⁽⁶⁾
I/O Capacity (Class 0/1) - packets/second ^{(7) (8)}	Not applicable	<ul style="list-style-type: none"> 128,000 without CIP Security™ 40,000 with integrity 20,000 with integrity and confidentiality
Message Rate Capacity HMI/MSG (Class 3) - messages/second ^{(7) (8)(9)}		
front port	Not applicable	<ul style="list-style-type: none"> 2000 without CIP Security 1500 with integrity 900 with integrity and confidentiality
backplane ⁽¹⁰⁾		<ul style="list-style-type: none"> 4000 via local communication modules
backplane in Logix redundancy ⁽¹⁰⁾		<ul style="list-style-type: none"> 2000 via local communication modules
Unconnected message buffers	20 outgoing buffers, configurable to 40 4 incoming buffers	320 incoming buffers 448 outgoing buffers
Concurrent cached message instructions in the running state	32, drawn from the 500 total connections supported by the controller	256 dedicated buffers
HMI and Messaging (Class 3)	Drawn from the 500 total connections supported by the controller	512 dedicated messages (256 incoming messages and 256 outgoing messages)
Integrated motion	<ul style="list-style-type: none"> EtherNet/IP network SERCOS interface Analog options (encoder input, LDT input, SSI input) 	<ul style="list-style-type: none"> EtherNet/IP network SERCOS interface⁽³⁾ Analog options (encoder input, LDT input, SSI input)⁽³⁾
Motion axes	128, any combination of these supported axis types: <ul style="list-style-type: none"> CIP™ Consumed Virtual Position loop drives Servo Servo drive Generic 	256, any combination of these supported axis types: <ul style="list-style-type: none"> CIP Consumed Virtual Position loop drives
Axes/ms over backplane	8	19

Attribute	ControlLogix 5570 Controller	ControlLogix 5580 Controller
Axes/ms over EtherNet/IP port	Not applicable	20 when you use the built-in EtherNet/IP port at 1 Gbps. Rockwell Automation recommends that you use the built-in EtherNet/IP port for high-performance motion applications.
Voltage and current ratings	800 mA @ 5.1V DC 5.0 mA @ 1.2V DC	1.2 A @ 5.1V DC 5.0 mA @ 1.2V DC
Energy storage module	<ul style="list-style-type: none"> 1756-ESMCAP capacitor energy storage module (removable) 1756-ESMNSE capacitor energy storage module (removable) 1756-ESMNRM capacitor energy storage module (nonremovable) 	Embedded in controller, nonremovable
Weight, approx	0.25 kg (0.55 lb)	0.394 kg (.868 lb)
Wire category ⁽¹¹⁾	3 - on USB port	3 - on USB port 2 - on Ethernet port
Wire size	Not applicable	Ethernet cabling and installation according to IEC 61918 and IEC 61784-5-2
Reset Button	Not applicable	<ul style="list-style-type: none"> A stage 1 reset clears the user application program and memory, but retains the controller IP address. A stage 2 reset returns the controller to out-of-box settings (including firmware), and clears all network settings.

- (1) The 5580 controllers allocate memory as needed, so there is no dedicated I/O memory space.
- (2) With Studio 5000 Logix Designer application, version 32.00.00 or later.
- (3) With Studio 5000 Logix Designer application, version 31.00.00 or later.
- (4) With Studio 5000 Logix Designer application, version 36.00.00 or later.
- (5) With Studio 5000 Logix Designer application, version 35.00.00 or later.
- (6) This is the recommended maximum. Additional EtherNet/IP nodes may be possible depending on remaining controller resources.
- (7) I/O numbers are maximums; they assume no HMI/MSG. HMI/MSG numbers are maximums, they assume no I/O. Maximums assume that the processor is the target, not the originator. Packet rates vary depending on packet size. For more details, see Troubleshoot EtherNet/IP Application Technique, publication [ENET-AT003](#), and the EDS file for a specific catalog number.
- (8) For information on integrity and confidentiality, see the CIP Security with Rockwell Automation Products Application Technique, publication [SECURE-AT001](#).
- (9) Maximums assume that the processor is the target, not the originator.
- (10) Controller performance not impacted by CIP Security.
- (11) Use this conductor category information for planning conductor routing. See the Industrial Automation Wiring and Grounding Guidelines, publication [1770-4.1](#).

GuardLogix Controllers

The GuardLogix 5580 controllers operate similarly to the GuardLogix 5570 controllers, with some differences.

Attribute	GuardLogix 5570 Controller	GuardLogix 5580 Controller
Instruction-based alarms (ALMA, ALMD)	Yes	Yes
Tag-based alarms	Not applicable	Yes
PanelView™ 5000	Not supported	Full support
User and Safety Memory	<ul style="list-style-type: none"> 1756-L71S: 2 MB + 1 MB Safety 1756-L72S: 4 MB + 2 MB Safety 1756-L73S: 8 MB + 4 MB Safety 	<ul style="list-style-type: none"> 1756-L81ES, 1756-L81EXTS: 3 MB + 1.5 MB Safety 1756-L82ES, 1756-L82EXTS: 5 MB + 2.5 MB Safety 1756-L83ES, 1756-L83EXTS: 10 MB + 5.0 MB Safety 1756-L84ES, 1756-L84EXTS: 20 MB + 6.0 MB Safety
I/O Memory	0.98 MB	Not applicable ⁽¹⁾
1756 ControlLogix Digital Safety I/O modules supported	Not supported	Full support with Studio 5000 Logix Designer Application, version 32.00.00 or later, with Add-on Profile.

Attribute	GuardLogix 5570 Controller	GuardLogix 5580 Controller
Remote I/O modules supported	<ul style="list-style-type: none"> • 1794 FLEX I/O • 1769 Compact I/O • 1756 ControlLogix I/O • 1734 POINT I/O • 1734 POINT Guard I/O • 1732E ArmorBlock • 1715 Redundant I/O 	<ul style="list-style-type: none"> • 5094 FLEX 5000 I/O⁽²⁾ • 5069 Compact 5000 I/O⁽³⁾ • 5034 PointMax I/O⁽⁴⁾ • 5032 ArmorBlock 5000 I/O⁽⁵⁾ • 5015 FLEXHA 5000 I/O⁽⁵⁾ • 1794 FLEX I/O • 1769 Compact I/O • 1756 ControlLogix I/O • 1734 POINT I/O • 1732E ArmorBlock • 1715 Redundant I/O
Embedded Ethernet	Not applicable	10/100/1000 Mbps
EtherNet/IP nodes supported, max	Controller connections: a total of 500 connections that are used for Ethernet I/O and Ethernet Messaging.	Count the number of Ethernet nodes included in the I/O configuration section of the Logix Designer application project. For more information, see Nodes on an EtherNet/IP Network on page 33 . <ul style="list-style-type: none"> • 1756-L81ES, 1756-L81EXTS: 100 • 1756-L82ES, 1756-L82EXTS: 175 • 1756-L83ES, 1756-L83EXTS: 250 • 1756-L84ES, 1756-L84EXTS: 250
I/O Capacity (Class 0/1) - packets/second ⁽⁶⁾⁽⁷⁾	Not applicable	<ul style="list-style-type: none"> • 128,000 without CIP Security™ • 40,000 with integrity • 20,000 with integrity and confidentiality
Message Rate Capacity HMI/MSG (Class 3) - messages/second ⁽⁶⁾⁽⁷⁾		
front port without safety partner	Not applicable	<ul style="list-style-type: none"> • 2000 without CIP Security • 1500 with integrity • 900 with integrity and confidentiality
front port with safety partner		<ul style="list-style-type: none"> • 1000 without CIP Security • 750 with integrity • 450 with integrity and confidentiality
backplane without safety partner ⁽⁸⁾		• 4000 via local communication modules
backplane with safety partner ⁽⁸⁾		• 2000 via local communication modules
backplane in Logix redundancy ⁽⁸⁾		• 2000 via local communication modules
Unconnected message buffers	20 outgoing buffers, configurable to 40 4 incoming buffers	320 incoming buffers 448 outgoing buffers
Concurrent cached message instructions in the running state	32, drawn from the 500 total connections supported by the controller.	256 dedicated buffers.
HMI and Messaging (Class 3)	Drawn from the 500 total connections supported by the controller.	512 dedicated messages (256 incoming messages and 256 outgoing messages)
Integrated motion	<ul style="list-style-type: none"> • SERCOS interface • Analog options (encoder input, LDT input, SSI input) • EtherNet/IP network 	<ul style="list-style-type: none"> • SERCOS interface • Analog options (encoder input, LDT input, SSI input) • EtherNet/IP network
Drive Safety Instructions with Kinetix® 5700 ERS4 Drives	Not applicable	Yes
Networked Safe Torque Off for Drives (CIP Mode/IO Mode)	Full support	Full support
Networked Safe Torque Off for Kinetix® (CIP Mode)	Full support	Full support

Attribute	GuardLogix 5570 Controller	GuardLogix 5580 Controller
Motion axes	100, any combination of these supported axis types: <ul style="list-style-type: none"> • CIP • Consumed • Virtual • Position loop drives • Servo • Servo drive • Generic 	256, any combination of these supported axis types: <ul style="list-style-type: none"> • CIP • Consumed • Virtual • Position loop drives
Axes/ms over backplane	8	19
Axes/ms over EtherNet/IP port	Not applicable	32 when you use the built-in EtherNet/IP port at 1 Gbps. Rockwell Automation recommends that you use the built-in EtherNet/IP port for high-performance motion applications.
Voltage and current ratings	800 mA @ 5.1V DC 5.0 mA @ 1.2V DC	1.2 A @ 5.1V DC 5.0 mA @ 1.2V DC
Energy storage module	<ul style="list-style-type: none"> • 1756-ESMCAP capacitor energy storage module (removable) • 1756-ESMNSE capacitor energy storage module (removable) • 1756-ESMNRM capacitor energy storage module (nonremovable) 	Embedded in controller, nonremovable
Weight, approx	0.25 kg (0.55 lb)	0.394 kg (.868 lb)
Wire category ⁽⁹⁾	3 - on USB port	3 - on USB port 2 - on Ethernet port
Wire size	Not applicable	Ethernet cabling and installation according to IEC 61918 and IEC 61784-5-2
Reset Button	Not applicable	<ul style="list-style-type: none"> • A controller stage 1 reset clears the user application program and memory, but retains the controller IP address. • A controller stage 2 reset returns the controller to out-of-box settings (including firmware), and clears all network settings. On a GuardLogix 5580 controller, the stage 2 reset also clears safety settings and the safety signature/safety locked state. • The Safety Partner reset returns the 1756-L8SP Safety Partner to the out-of-box settings (including firmware). • In a SIL 3 application, when you reset the GuardLogix Controller you must also reset the 1756-L8SP Safety Partner.

(1) The 5580 controllers allocate memory as needed, so there is no dedicated I/O memory space.

(2) With Studio 5000 Logix Designer application, version 32.00.00 or later.

(3) With Studio 5000 Logix Designer application, version 31.00.00 or later.

(4) With Studio 5000 Logix Designer application, version 36.00.00 or later.

(5) With Studio 5000 Logix Designer application, version 35.00.00 or later.

(6) I/O numbers are maximums; they assume no HMI/MSG. HMI/MSG numbers are maximums, they assume no I/O. Packet rates vary depending on packet size. For more details, see Troubleshoot EtherNet/IP Application Technique, publication [ENET-AT003](#), and the EDS file for a specific catalog number.

(7) For information on integrity and confidentiality, see the CIP Security with Rockwell Automation Products Application Technique, publication [SECURE-AT001](#).

(8) Controller performance not impacted by CIP Security.

(9) Use this conductor category information for planning conductor routing. See the Industrial Automation Wiring and Grounding Guidelines, publication [1770-4.1](#).

Controller Dimensions

This section shows dimensional differences.

ControlLogix 5570 Dimensions

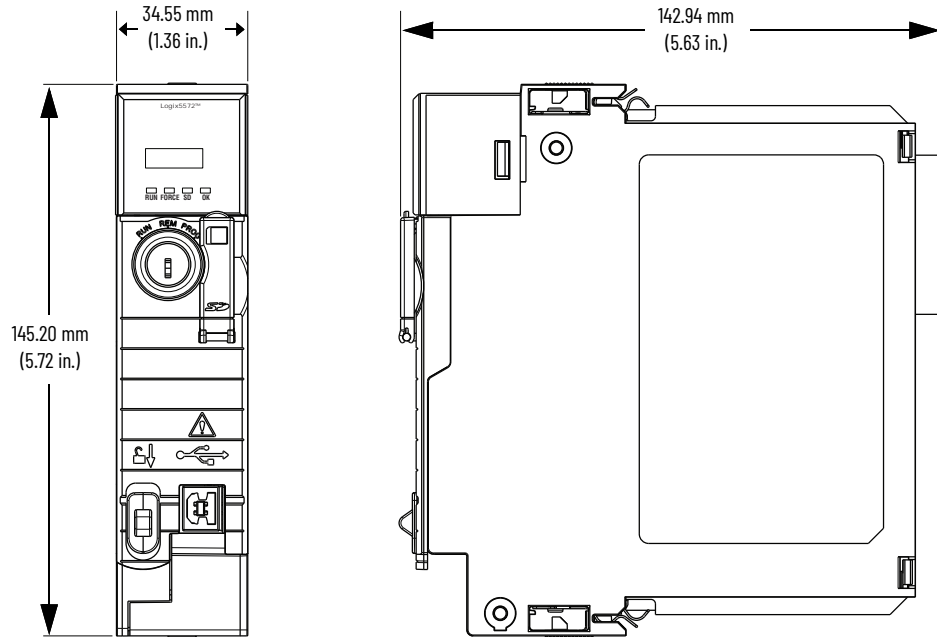

ControlLogix 5580 Dimensions

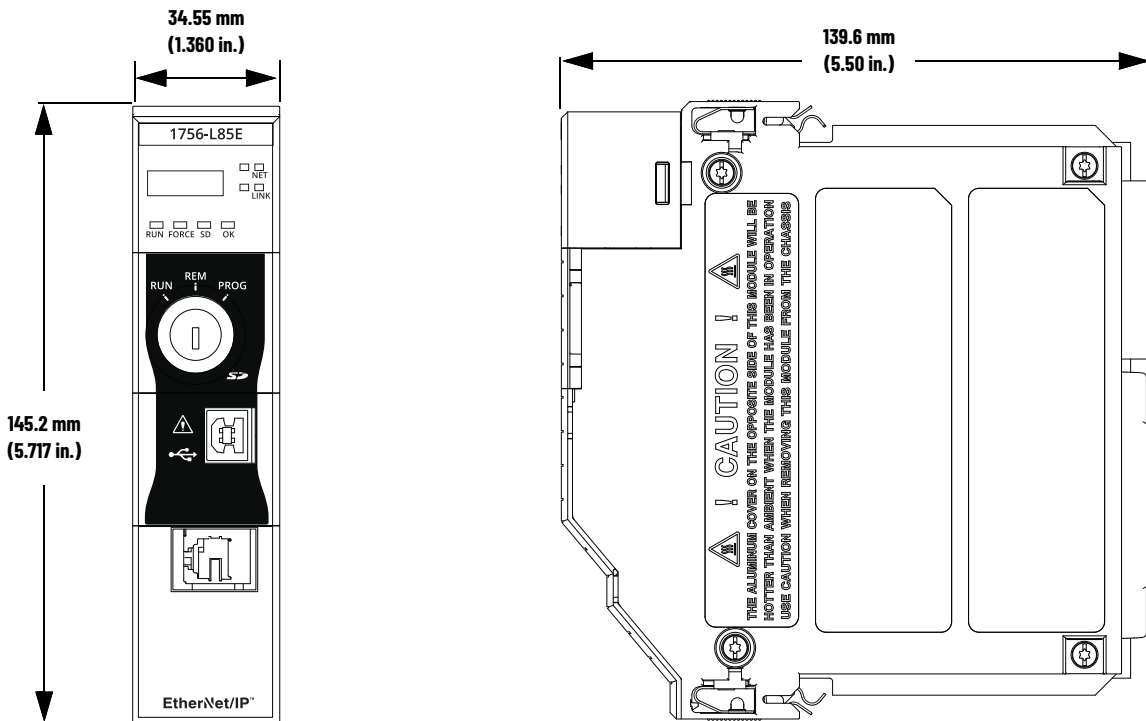

GuardLogix 5570 Dimensions

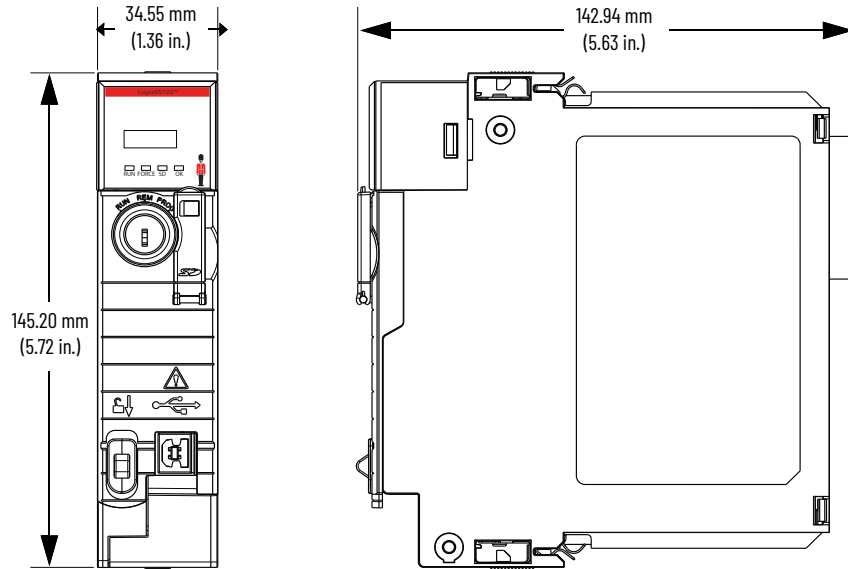

GuardLogix 5580 Dimensions

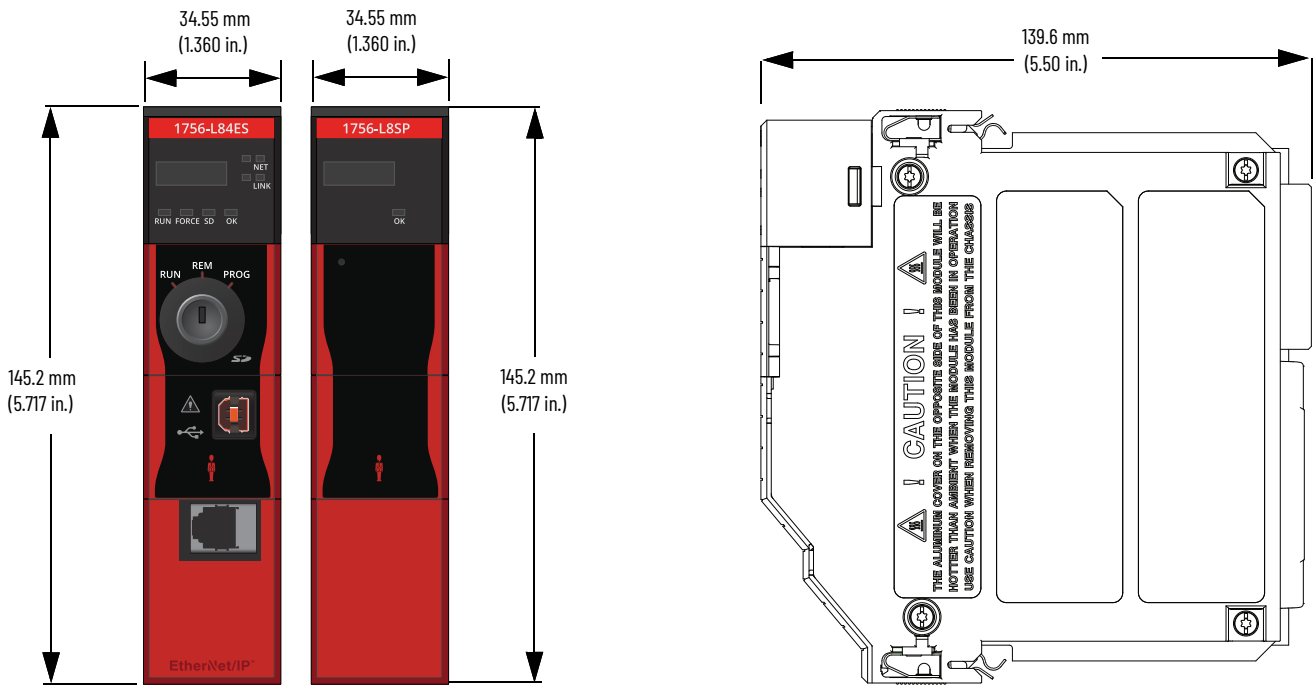

Connectors and Status Indicators

This section shows the front plate differences. For more information on the status indicators and reset button, see Chapter 9, [Diagnostics and Status Indicators with ControlLogix Systems on page 179.](#)

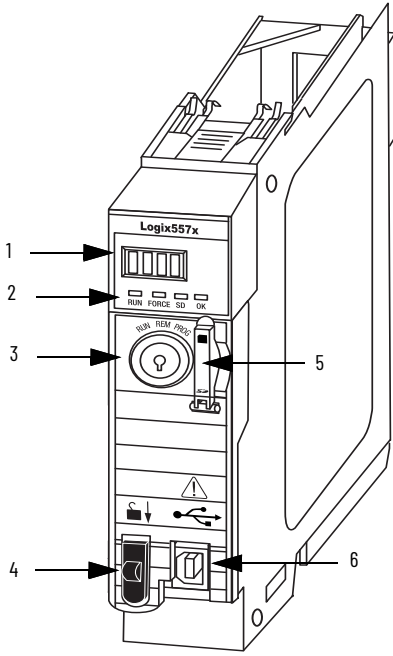
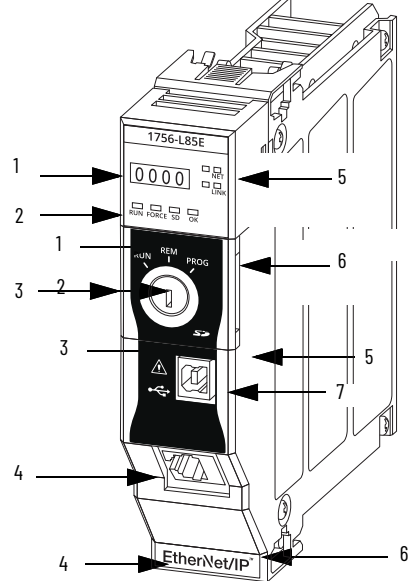
ControlLogix 5570	ControlLogix 5580																														
																															
<table border="1" style="width: 100%; border-collapse: collapse;"> <thead> <tr> <th style="width: 10%;">Item</th> <th style="width: 90%;">Description</th> </tr> </thead> <tbody> <tr> <td>1</td> <td>4-character Display</td> </tr> <tr> <td>2</td> <td>Status Indicators</td> </tr> <tr> <td>3</td> <td>REM RUN PROG Keyswitch</td> </tr> <tr> <td>4</td> <td>Energy Storage Module Release</td> </tr> <tr> <td>5</td> <td>SD Card slot behind the door⁽¹⁾</td> </tr> <tr> <td>6</td> <td>USB Port</td> </tr> </tbody> </table> <p>(1) The door opens from top to bottom.</p>	Item	Description	1	4-character Display	2	Status Indicators	3	REM RUN PROG Keyswitch	4	Energy Storage Module Release	5	SD Card slot behind the door ⁽¹⁾	6	USB Port	<table border="1" style="width: 100%; border-collapse: collapse;"> <thead> <tr> <th style="width: 10%;">Item</th> <th style="width: 90%;">Description</th> </tr> </thead> <tbody> <tr> <td>1</td> <td>4-character Display</td> </tr> <tr> <td>2</td> <td>Status Indicators</td> </tr> <tr> <td>3</td> <td>REM RUN PROG Keyswitch</td> </tr> <tr> <td>4</td> <td>Ethernet Port</td> </tr> <tr> <td>5</td> <td>Ethernet Status Indicators</td> </tr> <tr> <td>6</td> <td>SD Card slot and Reset button are behind the door.⁽¹⁾</td> </tr> <tr> <td>7</td> <td>USB Port</td> </tr> </tbody> </table> <p>(1) First remove the key, then open the door from right to left.</p>	Item	Description	1	4-character Display	2	Status Indicators	3	REM RUN PROG Keyswitch	4	Ethernet Port	5	Ethernet Status Indicators	6	SD Card slot and Reset button are behind the door. ⁽¹⁾	7	USB Port
Item	Description																														
1	4-character Display																														
2	Status Indicators																														
3	REM RUN PROG Keyswitch																														
4	Energy Storage Module Release																														
5	SD Card slot behind the door ⁽¹⁾																														
6	USB Port																														
Item	Description																														
1	4-character Display																														
2	Status Indicators																														
3	REM RUN PROG Keyswitch																														
4	Ethernet Port																														
5	Ethernet Status Indicators																														
6	SD Card slot and Reset button are behind the door. ⁽¹⁾																														
7	USB Port																														

GuardLogix 5570

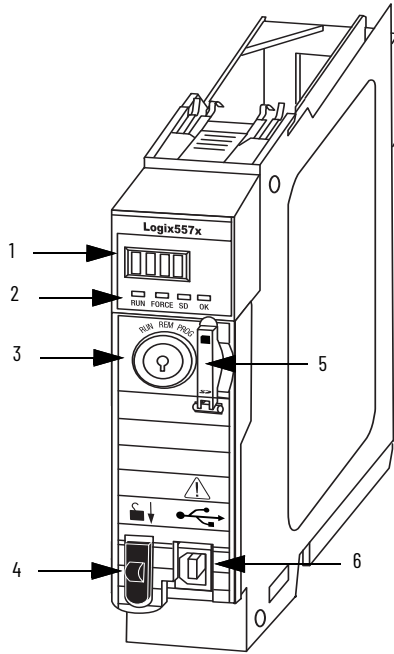

Item	Description
1	4-character Display
2	Status Indicators
3	REM RUN PROG Keyswitch
4	Energy Storage Module Release
5	Memory Card slot behind the door ⁽¹⁾
6	USB Port

(1) The door opens from top to bottom.

GuardLogix 5580 and Safety Partner

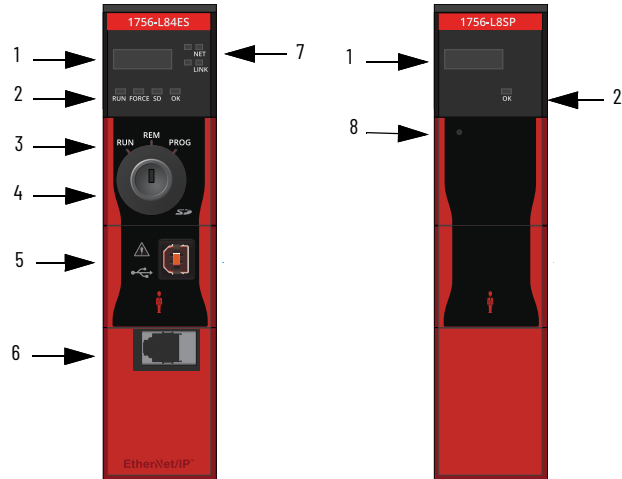

Item	Description
1	4-character display
2	Status Indicators
3	REM RUN PROG Keyswitch
4	SD card slot and Reset Button behind the door ⁽¹⁾
5	USB Port
6	Ethernet Port
7	Ethernet Status Indicators
8	Safety Partner Reset Button

(1) First remove the key, then open the door from right to left.

Configure the Controller

You must consider how to best use controller resources when ControlLogix controllers communicate over an EtherNet/IP network. There are limitations concerning how much EtherNet/IP communication the controller supports.

Consider the following:

- Connections
- Ethernet Nodes

Connections Overview

A Logix 5000® controller provides connection resources whenever communications are established between two devices.

Connections are used when the system contains the following conditions or activities:

- I/O modules, communication modules, and adapters are present in the I/O configuration of the user project
- Produced or Consumed tags are configured in the user project
- Connected Messages are executed in the user application
- External devices, programming terminals, or HMIs communicate with the controller

You must track the number of connections that are used when you configure a ControlLogix 5570 control system.

Nodes on an EtherNet/IP Network

When used in a Logix Designer application project, version 28 or later, 5580 controllers offer a simplified method for counting controller resources. 5590 controllers offer the same method.

When you configure a 5590 or 5580 control system, you simply count the number of Ethernet nodes that you include in the I/O configuration section of your Logix Designer application project.

On the Controller Properties dialog box, the Logix Designer application project displays the updated number of nodes that are used as you add Ethernet nodes to the project.

To see an example of how the project displays the node count, see [Figure 3 on page 39](#). [Table 4](#) lists the EtherNet/IP node limits for 5580 controllers.

Table 4 - ControlLogix 5580 and GuardLogix 5580 Controllers EtherNet/IP Node Guidelines

Cat. No.	Maximum Number of EtherNet/IP Nodes Supported			
	Logix Designer Application, Version 28	Logix Designer Application, Version 29	Logix Designer Application, Version 30	Logix Designer Application, Version 31 or later
1756-L81E	Not applicable	60	100	100
1756-L82E	Not applicable	80	175	175
1756-L83E	100	100	250	250
1756-L84E	Not applicable	150	250	250
1756-L85E	300 ⁽¹⁾	300 ⁽¹⁾	300 ⁽¹⁾	300 ⁽¹⁾
1756-L81ES	Not applicable			100
1756-L82ES	Not applicable			175
1756-L83ES	Not applicable			250
1756-L84ES	Not applicable			250

(1) This is the recommended maximum. Additional EtherNet/IP nodes may be possible depending on remaining controller resources.

Devices Included in the Node Count

Any devices that you add directly to the I/O configuration section are counted toward the node limits of the controller. The following are example devices that must be counted:

- Remote communication adapters
- Devices with an embedded EtherNet/IP port, such as I/O modules, drives, and linking devices
- EtherNet/IP devices that are connected to a communication module in the local chassis
- Remote controllers when a produce/consume connection is established between the two controllers
- HMI devices that are included in the I/O configuration tree
- Third-party devices that are directly connected to the EtherNet/IP network

Devices Excluded from the Node Count

Ethernet devices that exist on the EtherNet/IP network but are not added to the I/O configuration of the project do not count as nodes. These items are not added to the I/O configuration and are not considered nodes:

- Computer
- EtherNet/IP communication modules that reside in the local chassis with the controller
- HMI that is not added to the I/O configuration section
- MSG instruction
- Standard Ethernet devices for which the controller uses a socket interface to communicate

New Project Dialog Box

When you create a project with a 5580 controller, the Module Definition dialog box appears. The dialog box provides standard controller settings, along with additional security settings. The information that is entered in this dialog box displays on the Controller Properties General tab and Security tab.

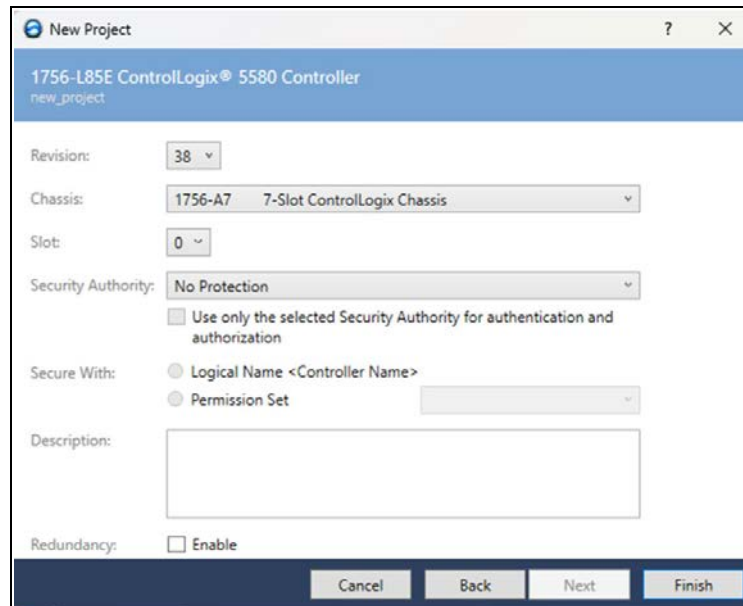

The screenshot shows the 'New Project' dialog box for a '1756-L85E ControlLogix® 5580 Controller'. The dialog box has a title bar with a question mark and a close button. Below the title bar, the controller model and a project name 'new_project' are displayed. The main area contains several configuration options:

- Revision:** A dropdown menu set to '38'.
- Chassis:** A dropdown menu set to '1756-A7 7-Slot ControlLogix Chassis'.
- Slot:** A dropdown menu set to '0'.
- Security Authority:** A dropdown menu set to 'No Protection'. Below it is a checkbox labeled 'Use only the selected Security Authority for authentication and authorization', which is currently unchecked.
- Secure With:** Two radio buttons: 'Logical Name <Controller Name>' (selected) and 'Permission Set'. A dropdown menu is visible next to the 'Permission Set' option.
- Description:** A large empty text box.
- Redundancy:** A checkbox labeled 'Enable', which is currently unchecked.

At the bottom of the dialog box, there are four buttons: 'Cancel', 'Back', 'Next', and 'Finish'.

Controller Properties

This table compares the Controller Properties Tab.

Controller Properties Tab	Comments
General	Same functionality as 5570 controllers
Major Faults	Same functionality as 5570 controllers
Minor Faults	Same functionality as 5570 controllers
Date/Time	Same functionality as 5570 controllers
Advanced	New parameter to enable Minor Overflow fault reporting. See Advanced Tab on page 37
SFC Execution	Same functionality as 5570 controllers
Project	Same functionality as 5570 controllers
Redundancy	Available in version 33 or later with the same functionality as the ControlLogix 5570 controllers Not available on GuardLogix 5570 controllers.
Nonvolatile Memory	Same functionality as 5570 controllers
Memory (Logix Designer application, version 28) Capacity (Logix Designer application, version 29 and later)	The tabs indicate the same information but are named differently between the Logix Designer application versions. Indicates data usage. Data usage is indicated with one value that combines Data and Logic memory usage and I/O memory usage. See Memory Tab on page 38 or Capacity Tab on page 39 .
Internet Protocol	New for 5580 controllers. See Internet Protocol Tab on page 41 .
Port Configuration	New for 5580 controllers. See Port Configuration Tab on page 42 .
Security	Additional security parameters. See Security Tab on page 43 .
Alarm Log	Not available for 5580 controllers in version 28. Available in version 29 or later with the same functionality as the 5570 controllers.
Safety (GuardLogix controllers only)	5580 controllers let you choose a safety level and set a safety network number for the Ethernet port.
OPC UA	New for 5580 controllers. See Internet Protocol Tab on page 41 .

Advanced Tab

The Advanced tab provides a way to assign the Controller Fault Handler and Power-up Handler. You can also match a project to a specific controller by serial number.

- Report Overflow Faults is a new parameter that lets you control Minor Overflow fault reporting. When you create a project, the default setting is disabled. When you import or open a legacy project, the default setting is enabled. For more information, see [Minor Fault on Overflow on page 166](#).
- System Overhead Time Slice is no longer required for 5580 controllers, and the parameter is removed.
- Enable Automatic Diagnostics is available on 5580 controllers.

Figure 1 - Controller Properties Dialog Box - Advanced Tab

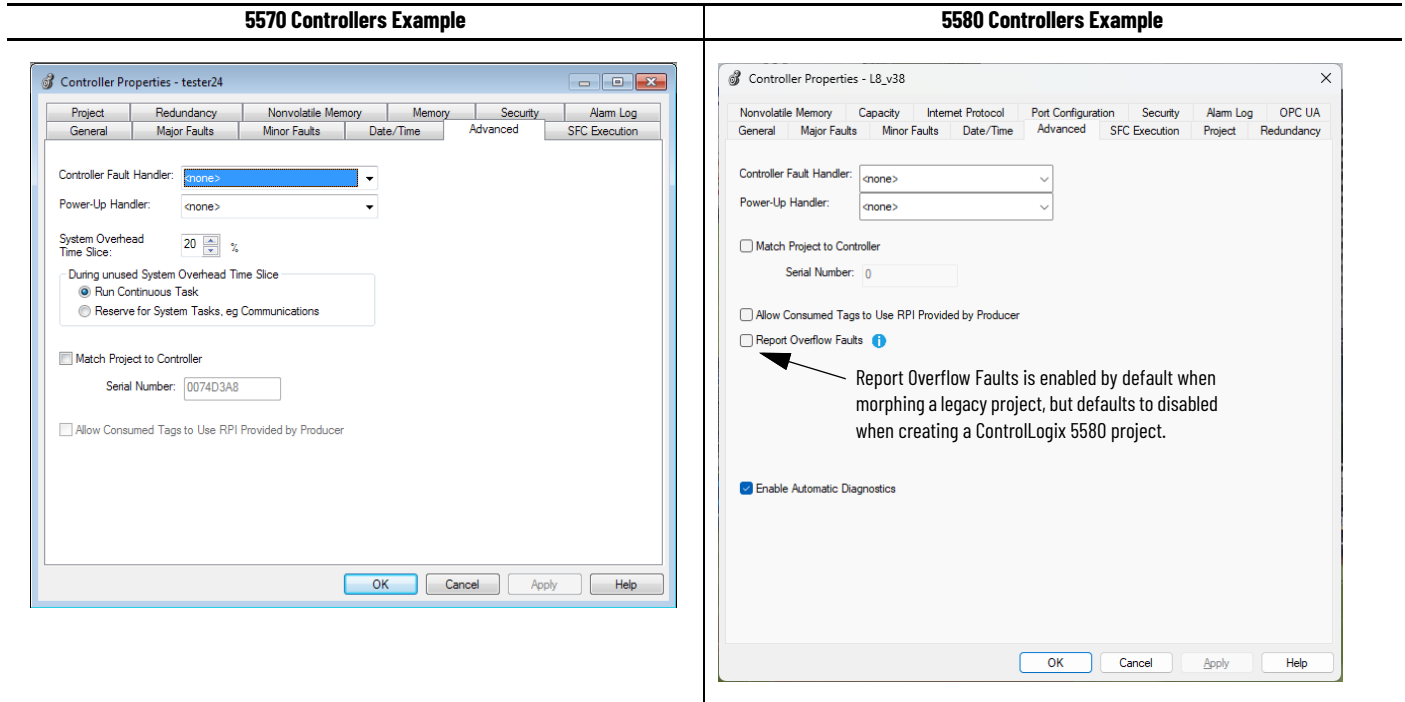

Memory Tab

In the Logix Designer application, version 28 or earlier, the Memory tab indicates data usage.

- **5570 controllers** - Data usage is indicated with two values. The tab shows I/O memory and Data and Logic memory separately.

As you change the project, you can click Estimate to see the estimated memory usage and remaining available memory.

- **5580 controllers** - Data usage is indicated with one value that combines Data and Logic memory usage and I/O memory usage.

As you change the project, the data values are automatically updated to indicate the estimated memory usage and remaining available memory.

IMPORTANT Programmatic access to memory is not supported for 5580 controllers, see [Controller Memory Usage on page 140](#).

Figure 2 - ControlLogix Controller Properties Dialog Box - Memory Tab

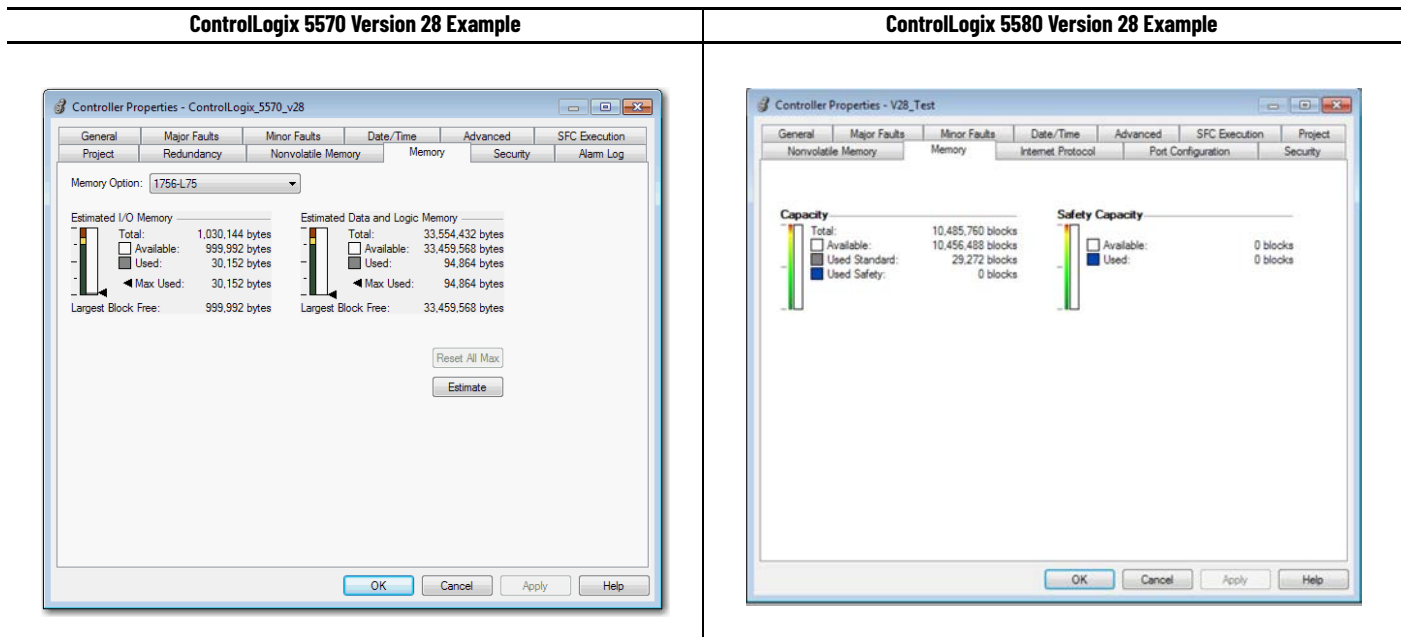

Capacity Tab

In the Logix Designer application, version 29 or later, the Capacity tab indicates data usage.

- 5570 controllers** - Two values show data usage. The tab shows I/O memory and Data and Logic memory separately. GuardLogix 5570 controllers also show the Safety memory.

As you change the project, you can click Estimate to see the estimated memory usage and remaining available memory.

- 5580 controllers** - Data usage is indicated with one value that combines Data and Logic memory usage and I/O memory usage. The tab also shows the number of Ethernet nodes that are used. GuardLogix 5580 controllers also show the Safety capacity.

As you change the project, the data values are automatically updated to indicate the estimated memory usage and remaining available memory. The number of Ethernet nodes is also updated automatically.

As you change the project, the data values are automatically updated.

Figure 3 - ControlLogix Controller Properties Dialog Box - Capacity Tab

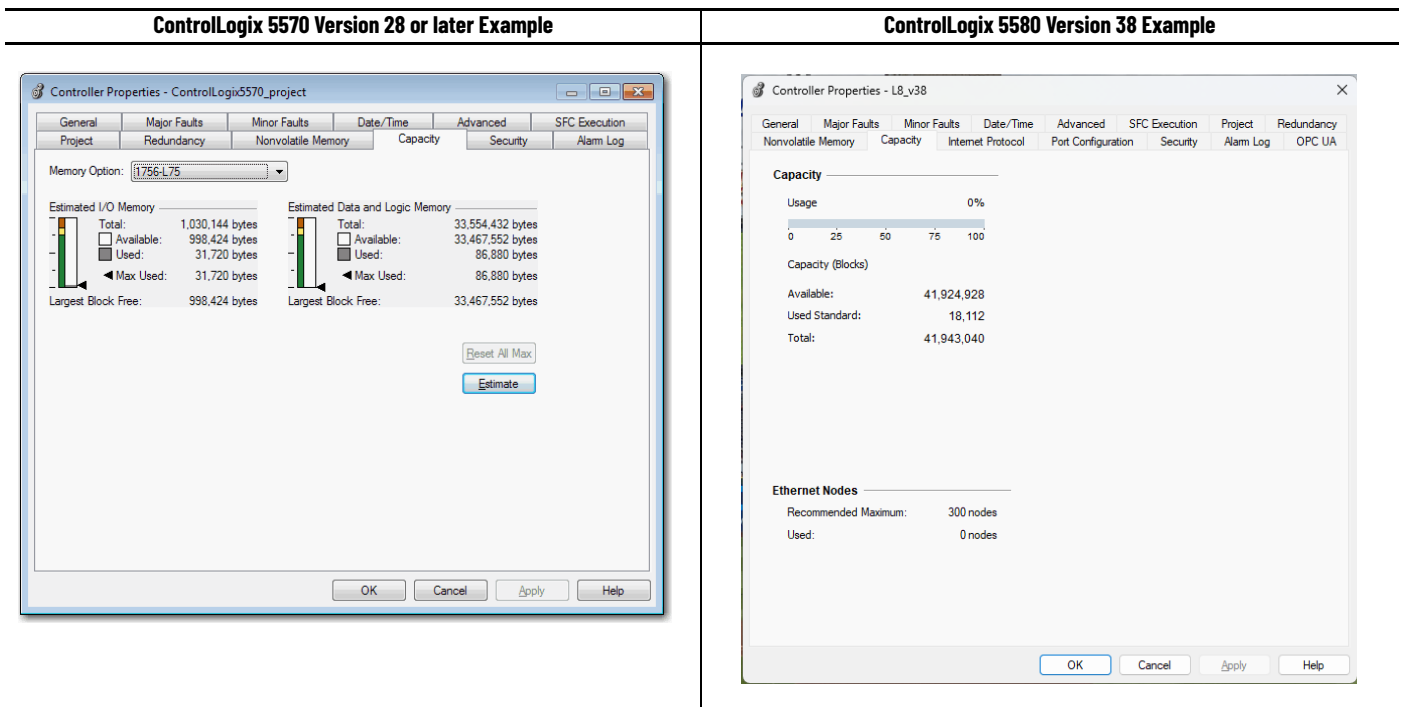
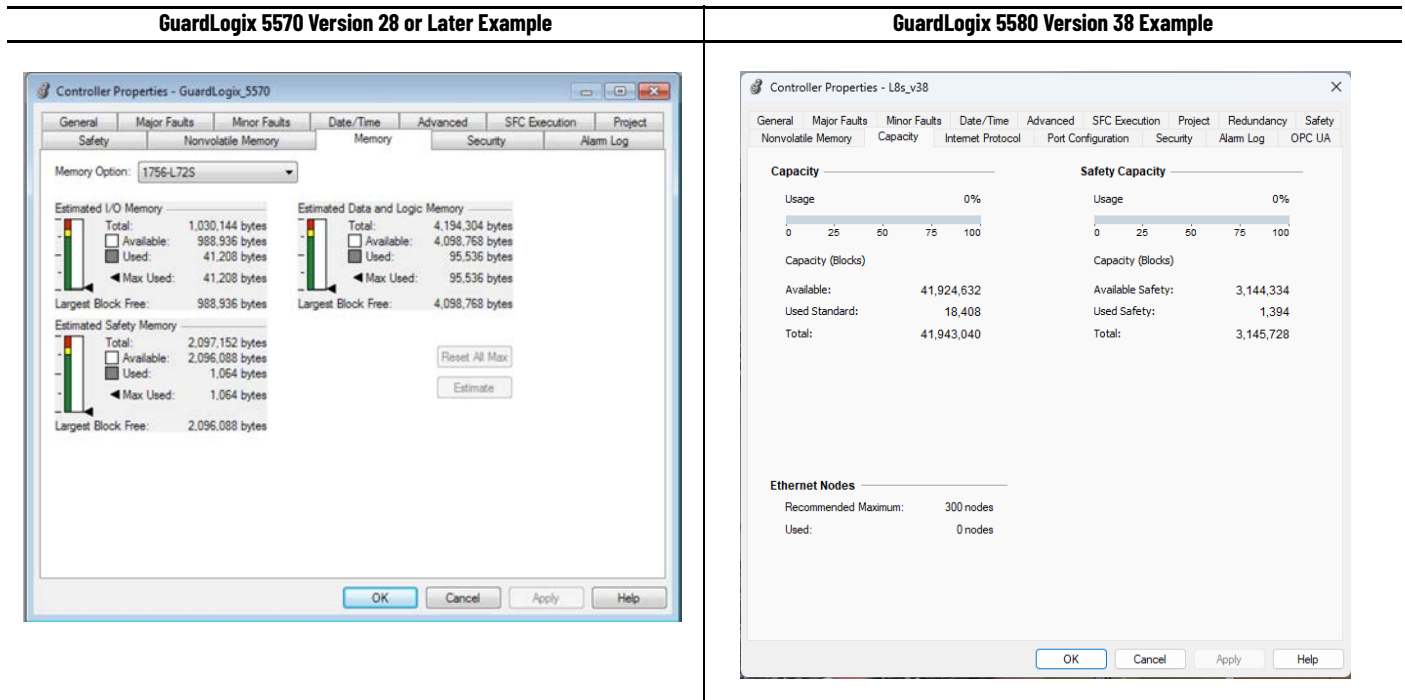

Figure 4 - GuardLogix Controller Properties Dialog Box - Capacity Tab



Internet Protocol Tab

When online with the controller, the Internet Protocol tab lets you configure the IP Settings. These settings are not available offline.

Figure 5 - Controller Properties Dialog Box - Internet Protocol Tab - Online

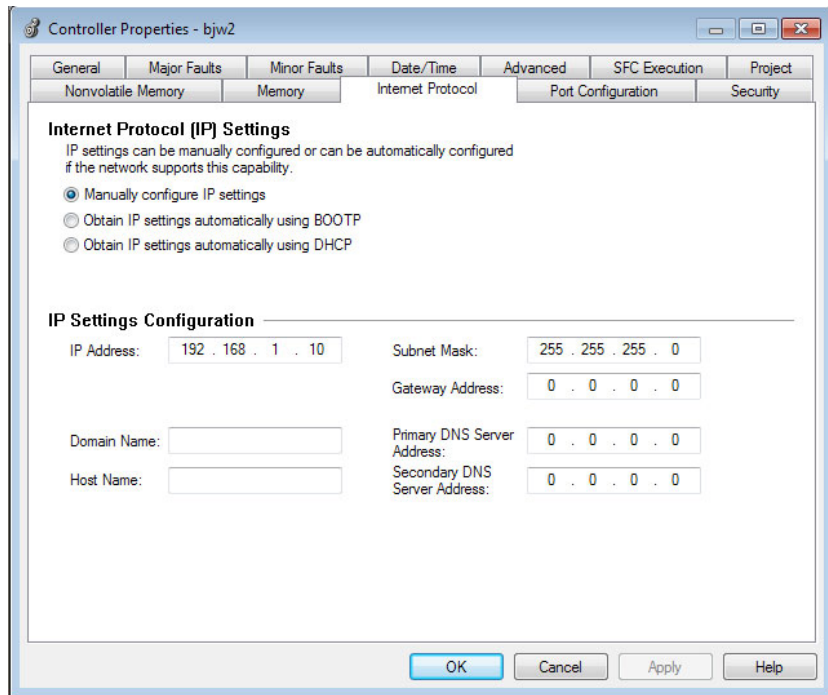

When online, configurable settings include the following:

- Source of IP Settings (DHCP, BOOTP, or manual configuration)
- Physical Module IP Address
- Subnet Mask
- Gateway Address
- Domain Name
- Host Name, Primary DNS Server Address
- Secondary DNS Server Address

IMPORTANT The Internet Protocol tab is not available with 5570 controllers.

Port Configuration Tab

When online, the Port Configuration tab lets you view and configure the Ethernet port settings:

- View Link Status
- Enable/Disable the Ethernet port
- Configure Auto-Negotiate
- Configure Selected Speed up to 1 Gbps (or set to auto-negotiate)
- View Current Speed
- Configure Selected Duplex
The 5580 controllers only support full-duplex.
- View Current Duplex
- Access the Port Diagnostics dialog

You can change the Port Configuration parameters without resetting the controller.

Figure 6 - Controller Properties Dialog Box - Port Configuration Tab

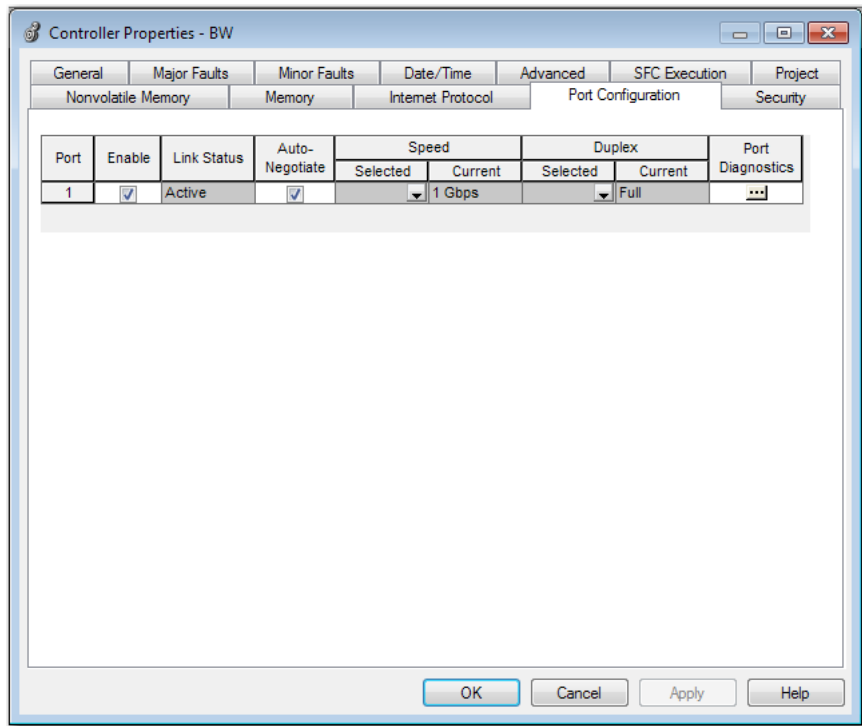

IMPORTANT The Port Configuration tab is not available with 5570 controllers.

Port Diagnostics

On the Port Configuration category, click the Port Diagnostics button to view information for the Ethernet port. For parameter descriptions, see the ControlLogix 5580 and GuardLogix 5580 Controllers User Manual, publication [1756-UM543](#).

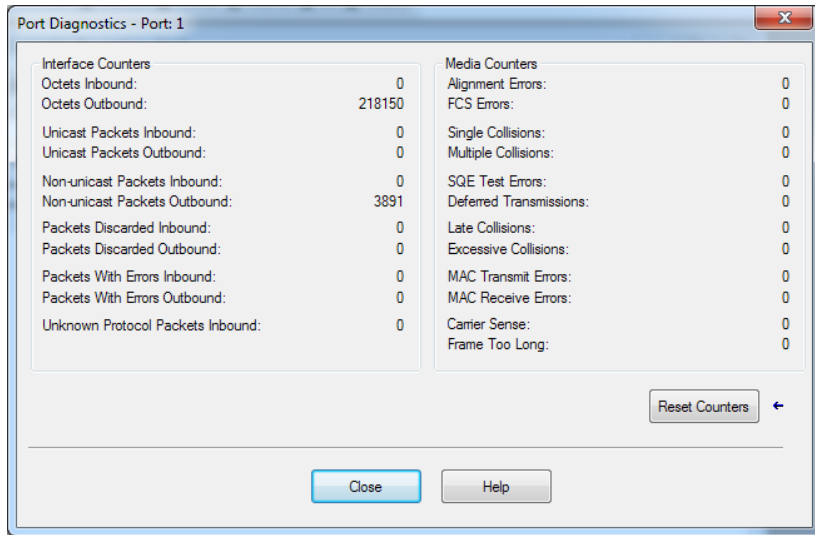

Security Tab

The Security Tab lets you see the controller security settings, for example, the Security Authority choice. Security settings are configured when you create the project.

With the Logix Designer application, version 28 or later, the 5580 controllers support additional parameters in the Security Authority section.

Figure 7 - Controller Properties Dialog Box - Security Tab

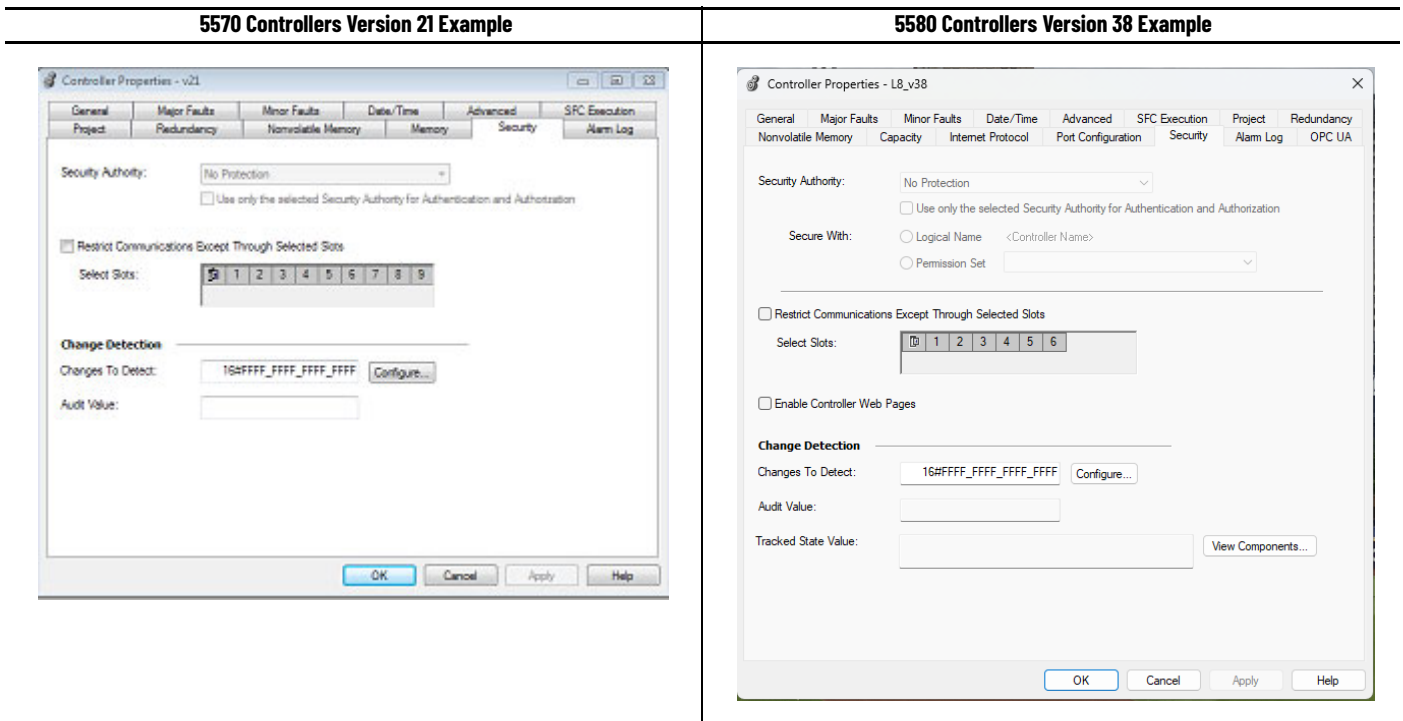

Safety Tab

The Safety tab lets you configure safety parameters based on system conditions. There are a few differences between the GuardLogix 5570 and GuardLogix 5580 controllers.

- Safety Level - GuardLogix 5580 controllers let you choose the Safety Level--SIL2/PLd or SIL3/PL3. GuardLogix 5570 controllers can only be used in SIL 2 applications.
- Safety Network Numbers - You can set a safety network number on GuardLogix 5580 controllers' built-in Ethernet port.
- Safety Signature - With firmware revision 38.011 or later, GuardLogix 5580 controllers can be in Remote Run, Program/Remote Program, or Remote Test mode to generate a safety signature.

With firmware revision 37 or earlier, the controllers must be in Program/Remote Program mode to generate a safety signature.

IMPORTANT The Safety tab is not available with ControlLogix 5580 or 5570 controllers.

Figure 8 - Controller Properties Dialog Box - Safety Tab

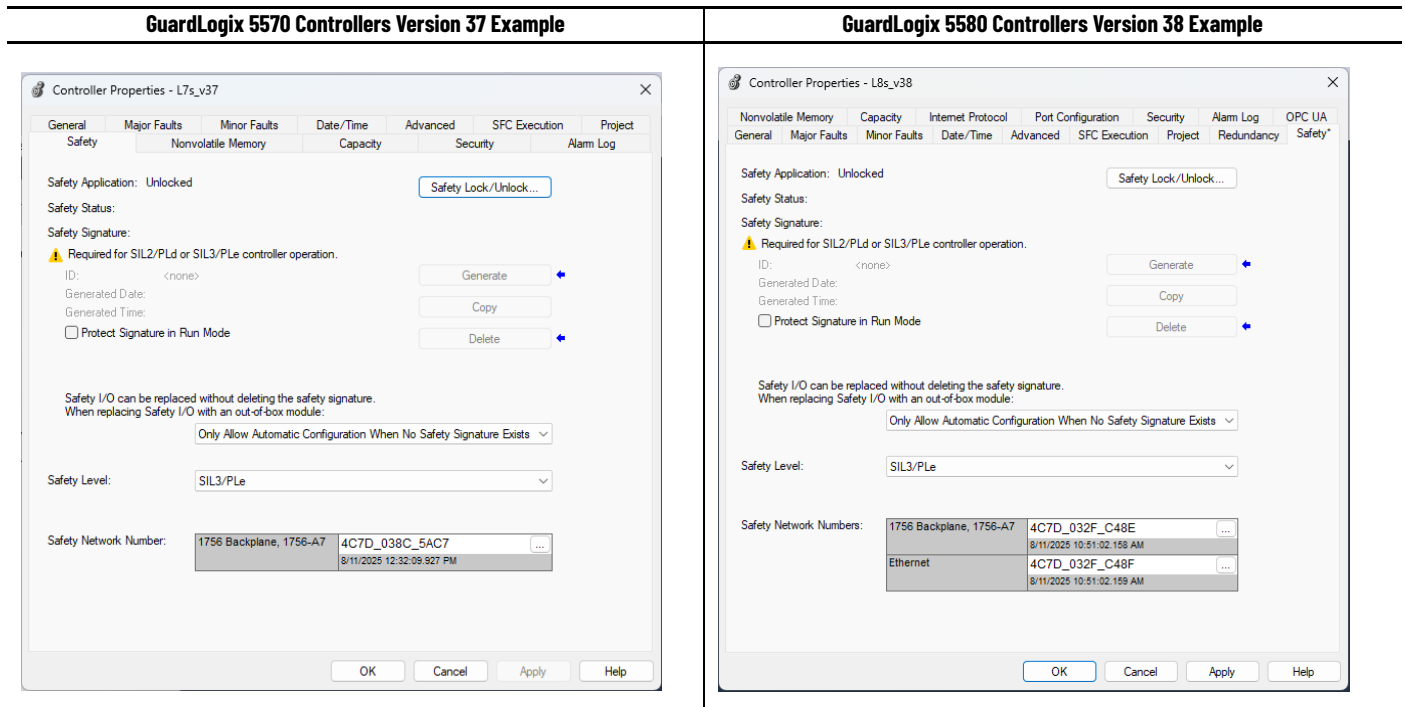

OPC UA Tab

You can enable OPC UA on a 5580 controller's Ethernet port.

Figure 9 - Controller Properties Dialog Box - OPC UA Tab - Online

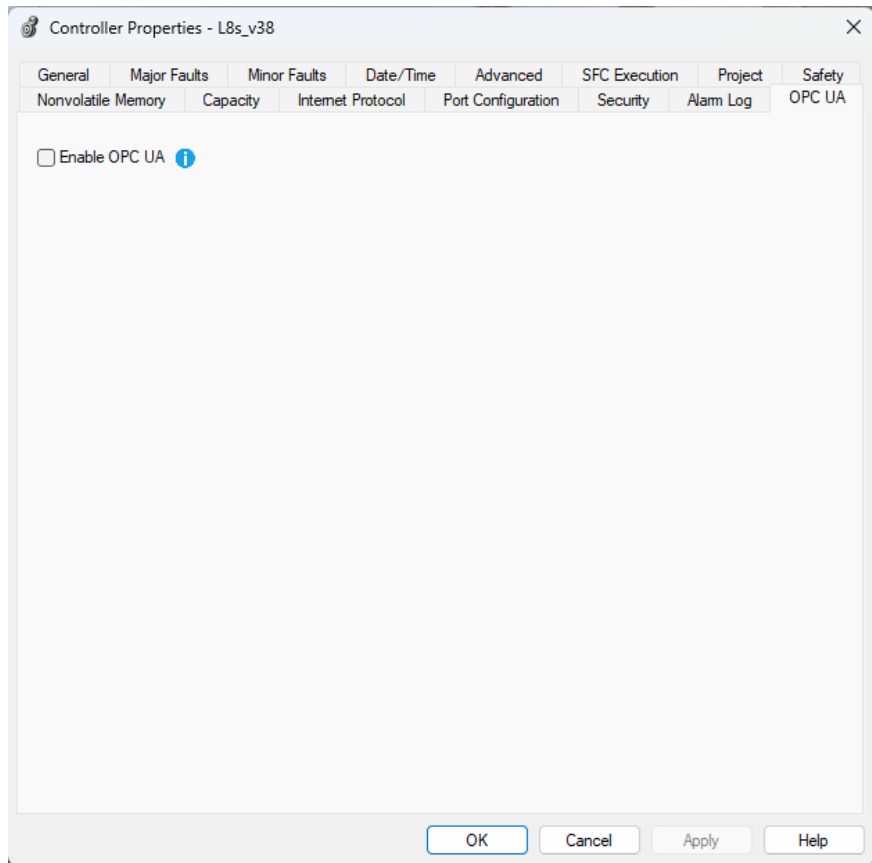

Controller Reset

You can clear the program from memory on the 5570 controllers. On 5580 controllers, you can clear the program from memory and reset the controller to factory default settings.

5570 Controllers

Clearing the program from the onboard NVS memory on the 5570 controllers and the 1756-L7SP Safety Partner, involves removing the Energy Storage Module.

For information on how to perform this procedure, see Knowledgebase Article [1756-L7x: Clearing Memory/Resetting Processor to Factory Default](#).

IMPORTANT When you clear the program on a GuardLogix 5570 Controller, you must also clear the 1756-L7SP Safety Partner.

5580 Controllers

You can clear the program from memory and reset the 5580 controllers and the 1756-L8SP Safety Partner with the reset button.

For information on how to use the reset button, see the ControlLogix 5580 and GuardLogix 5580 Controllers User Manual, publication [1756-UM543](#).

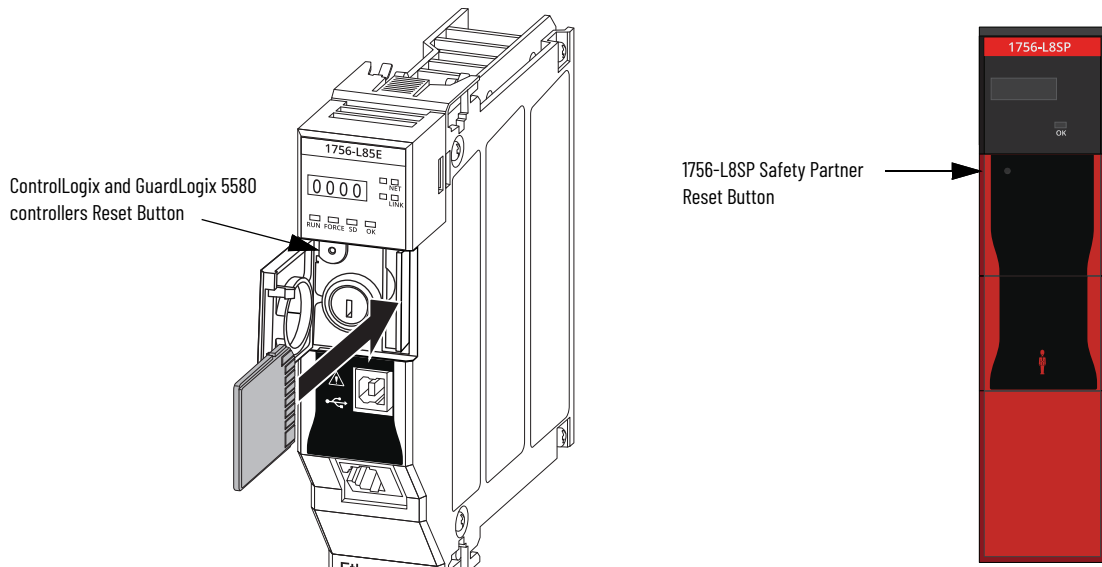

WARNING: When you press the reset button while power is on, an Electric Arc can occur. This could cause an explosion in hazardous location installations. Be sure that power is removed or the area is nonhazardous before proceeding.

IMPORTANT In a SIL 3 application, when you reset the GuardLogix 5580 Controller you must also reset the 1756-L8SP Safety Partner.

Memory Card Behavior

The controller has changed some behaviors when loading a project from the memory card into a controller. These changes facilitate a better workflow for easier commissioning of brand new out of box controllers. All Logix 5000® controllers ship from the factory with firmware revision 1.x.

With 5580 controllers, the Load Image setting On Uninitialized Memory is available. This setting replaces the On Corrupt Memory setting that is available with 5570 controllers.

The general behavior is the same for both settings. The only difference is the controller behavior when it is in the out-of-box condition, as described in [Table 5](#).

You can install a memory card that uses On Uninitialized Memory in an out-of-the box controller, that is, one that uses firmware revision 1.x. In this case, at power-up the image loads both the controller firmware and controller application.

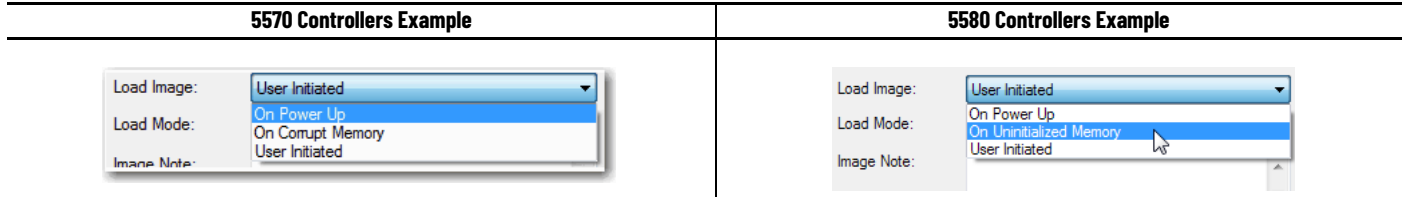

When you use a memory card with an image in an out-of-box controller (firmware revision 1.x), at power-up that controller updates its firmware to the revision stored on the card. The update happens regardless of the Load Image setting that you made when you transferred the image to the memory card.

The On Power Up, and On Initialized Memory settings also load the controller application into an out of box controller.

This table shows what happens at power-up when you insert a memory card that contains an image into a 5580 controller.

Table 5 - Memory Card Settings and Controller Power-up Behavior

Image Setting	Controller is in Out-of-Box Condition (v1.x firmware)	Firmware > 1.x and Internal Nonvolatile Memory is not Valid ⁽¹⁾	Firmware > 1.x and Internal Nonvolatile Memory is Valid ⁽¹⁾
User Initiated	Loads Firmware Only ⁽²⁾	Does Nothing	Does Nothing
On Power Up	Loads both Firmware and Application	<ul style="list-style-type: none"> Loads Firmware if there is a revision mismatch Loads Application 	<ul style="list-style-type: none"> Loads Firmware if there is a revision mismatch Loads Application
On Uninitialized Memory	Loads both Firmware and Application ⁽²⁾	<ul style="list-style-type: none"> Loads Firmware if there is a revision mismatch Loads Application 	Does Nothing

(1) "Valid" includes the No Project condition.

(2) Indicates change in behavior from ControlLogix 5570 and older controllers.

Communication Options

Several communication networks are available for use. This table describes typical network applications that are used, and lists the networks available to support such applications.

Application Type	5570 Controllers - Supported Networks	5580 Controllers - Supported Networks
Communication options	<ul style="list-style-type: none"> • EtherNet/IP • ControlNet® • DeviceNet® • Data Highway Plus™ (DH+) • Remote I/O • SynchLink™ (ControlLogix only) • USB 	
Integrated Motion	<ul style="list-style-type: none"> • EtherNet/IP • SERCOS interface • Analog options: <ul style="list-style-type: none"> - Encoder input - LDT input - SSI input 	<ul style="list-style-type: none"> • EtherNet/IP • SERCOS interface⁽¹⁾ • Analog options:⁽¹⁾ <ul style="list-style-type: none"> - Encoder input - LDT input - SSI input
Time Synchronization	EtherNet/IP - Available with Integrated Motion and non-motion applications	
Control of distributed I/O	<ul style="list-style-type: none"> • ControlNet • DeviceNet • EtherNet/IP • Foundation Fieldbus • HART • Universal Remote I/O 	
Produce/consume data between controllers	<ul style="list-style-type: none"> • ControlNet • EtherNet/IP 	
Messaging to and from other devices, including access to the controller via Logix Designer application	<ul style="list-style-type: none"> • ControlNet • DeviceNet (only to devices) • Data Highway Plus (DH+) • DH-485 • EtherNet/IP 	

(1) With Studio 5000 Logix Designer Application Version 31.00.00 or later.

Communication Throughput

Unlike 5570 controllers, which share the main core between application code and communications, 5580 controllers run communications asynchronously from the user application.

This implementation provides better communications throughput in both the bandwidth and speed of data the 5580 controllers can deliver to and from, for example, HMIs, Historians, and MES systems. It also improves the overall application performance as the controller no longer has to task switch and pause application execution to handle HMI or other class 3 traffic.

For 5570 and 5580 controllers, the controller runs communication asynchronously to the application, making sure communication that is delivered to the controller is complete before the application executes on the newly delivered data. This applies to both data that comes into the controller and data that goes out.

For example, if the HMI is writing a large block of recipe data to the controller, application code can start executing on that recipe data before the data writing process finishes. This action results in half of the current recipe and half of the last recipe in the application space.

Traditionally, programmers have used the following techniques to control the effects of asynchronous communications:

- UID/UIE pairs
- Periodic tasks
- Moving data with CPS instructions

The techniques all rely on controlling when the main core can switch tasks. This helps to prevent the communications task from changing data while the control task used it. Because the controller processes communications on an independent core of the CPU, then UID/UIE pairs and Periodic Tasks are not as effective in all cases.

The items that are highlighted in this table are where controller behavior differs.

Tag Read/Write Source	UID/UIE		CPS		Periodic Task	
	5580 Controllers	5570 Controllers	5580 Controllers	5570 Controllers	5580 Controllers	5570 Controllers
HMI	Allows	Blocks	Blocks	Blocks	Allows	Blocks
MSG	Allows	Blocks	Blocks	Blocks	Allows	Blocks
I/O Update	Allows	Allows	Blocks	Blocks	Allows	Allows
Produce/Consume	Allows	Allows	Blocks	Blocks	Allows	Allows
Other User Tasks	Blocks	Blocks	Blocks	Blocks	Allows	Allows
Motion Planner	Allows	Allows	Blocks	Blocks	Allows	Allows

Blocks - Stops source data values from changing by communications during application execution.

Allows - Communications can change source data values during application execution.

Because the ControlLogix 5570, ControlLogix 5580 and GuardLogix 5580 controllers have 32-bit data integrity, this only applies to data structures larger than 32 bits. If word-level integrity is your primary concern, the 32-bit data integrity does not impact your data use.

Good programming practice dictates the use of two unique words at the beginning and the end of data. The controller validates the words to assure the entire structure has data integrity. We recommend that the handshake data is changed and the application code validates it every transaction before the controller application code or higher-level system reading controller data acts on it.

Download the Program to the Controller

The first time that you download a program, it can take longer than subsequent downloads. These situations can affect download/compile times:

- The capability of the personal computer or laptop.
- You download the project immediately after a project import or upload, but before Logix Designer has compiled the project once.
- You edit a User Defined Tag (UDT), Add-On Instruction (AOI), or an object that is used in many places.
- Increased load when Logix Designer compiles and generates code.

Project Size

The size of the .ACD file does not reflect the size of your project that downloads to the controller. The .ACD file contains multiple components. Not all components are downloaded to the controller.

Build Button

The new Build button in Logix Designer creates binary files that are compiled from user subroutines, and caches them in the project .ACD file.



If these files are present in the project during a download, then Logix Designer does not have to recompile them, and saves time during the download process.

Every download requires that only the changed subroutines must be recompiled. You can perform a build offline, save the project .ACD file, and later distribute it to many controllers without recompilation.

This manual build step is optional. If you do not use the build button, Logix Designer builds all necessary files when you initiate a download.

An imported project requires a complete rebuild, and extends the download process the first time you attempt a download.

[Downloading Workflow Change on page 51](#) provides an explanation of the download changes.

Downloading Workflow Change

Offline builds can save time when doing subsequent downloads.

5580 Controllers	5570 Controllers
Only changed source code is recompiled on a download.	All source code is recompiled on every project download.

Mitigation

Adjust your workflow to save workstations from having to rebuild the project. You can do offline builds, save the project file, and distribute it to other workstations to minimize your download times.

Upload Fidelity Change

When you upload, projects that contain program parameters and aliases now are consistently reproduced. The uploaded ladder diagram source code is an exact replica of what was downloaded. This was not the case in 5570 controller ladder diagram subroutines, which referenced aliases or program parameters.

Thermal Monitoring and Thermal Fault Behavior

The controllers can monitor internal module temperatures and respond as the temperature increases.

Figure 10 - Controller Thermal Fault Behavior

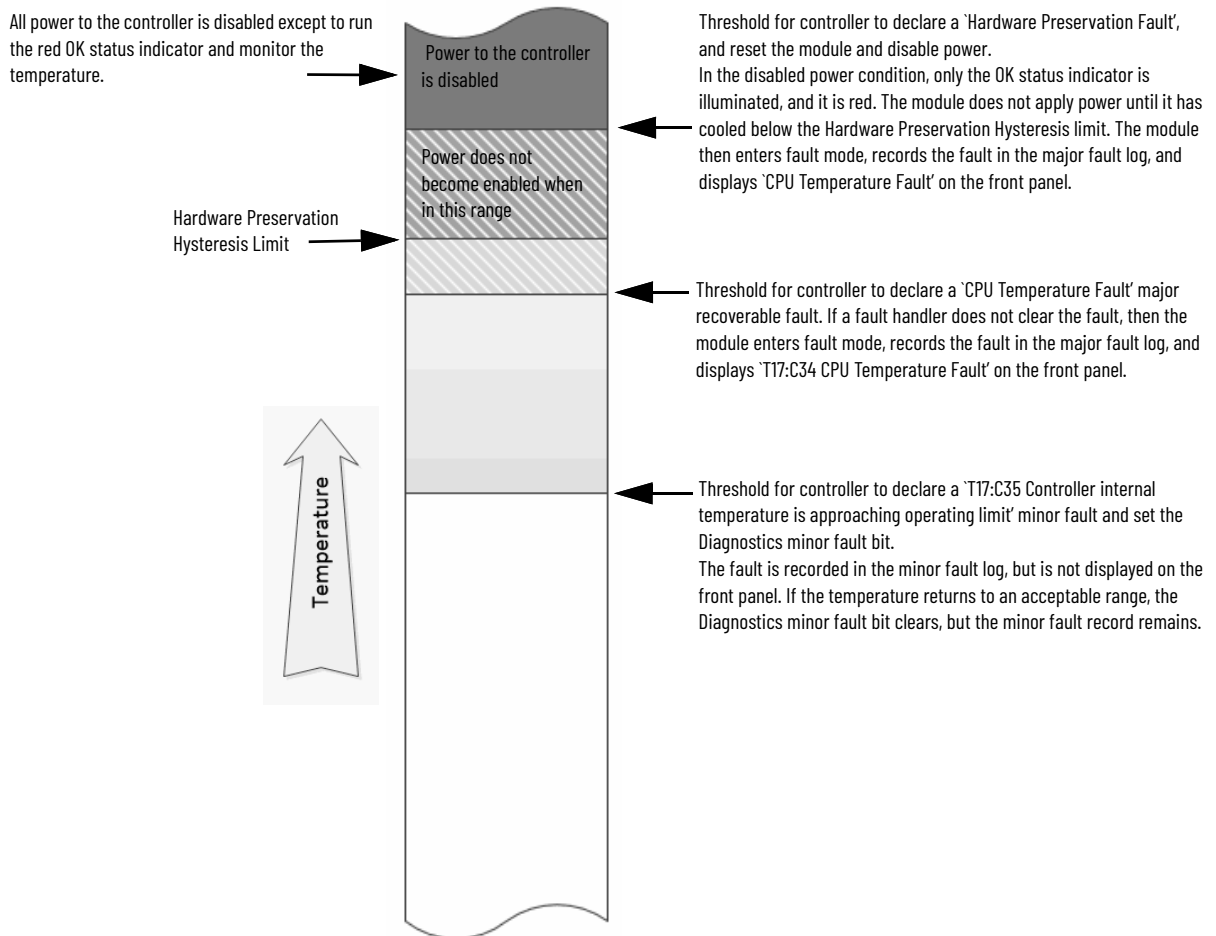

Notes:

Replacement Considerations with ControlLogix 5590 Systems

This chapter describes features and functions that are associated with the ControlLogix® 5590, ControlLogix 5580, and GuardLogix® 5580 controllers.

This chapter features these controllers, and where applicable, the controllers are known as:

Controller Family	Includes these controllers
5590 controllers	ControlLogix 5590 standard, ControlLogix-XT™ 5590 controllers, and ControlLogix-XT 5590 Process Controllers
5580 controllers	ControlLogix 5580 and GuardLogix 5580 controllers

IMPORTANT This chapter assumes that if you are migrating from 5570 controllers or earlier to 5590 controllers, you first read Chapter 2, [Replacement Considerations with ControlLogix 5580 and GuardLogix 5580 Systems on page 23](#).

It is not an exhaustive list of the features and functions available with the controllers.

- Embedded 10/100/1000 Mbps Ethernet port
- Higher performance and capacity including:
 - 5580 controllers:**
 - Motion Processing: 256 total axes
 - Total I/O packets processing: 128,000 pps
 - 320 unconnected message buffers
 - 256 simultaneous cached message instructions in the running state
 - Support for standard and safety I/O modules over an EtherNet/IP™ network
Safety I/O modules are only supported with GuardLogix 5580 controllers
 - 5590 controllers:**
 - Motion Processing: 512 total axes
 - Total I/O packets processing: 164,000 pps
 - 448 unconnected message buffers
 - 384 simultaneous cached message instructions in the running state
 - Support for standard and safety I/O modules over an EtherNet/IP™ network
 - Change Ethernet port speed without a module reset

Minimum Requirements

The 5580 and 5590 controllers have these minimum requirements.

ControlLogix Controllers Minimum Requirements

Requirement, Minimum	ControlLogix 5580 Controller	ControlLogix 5590 Controller (not safety-enabled)
Chassis	1756-A4, 1756-A4K, 1756-A7, 1756-A7K, 1756-A10, 1756-A10K, 1756-A13, 1756-A13K, 1756-A17, 1756-A17K 0 °C < Ta < +60 °C (+32 °F < Ta < +140 °F) for Series C Chassis 0 °C < Ta < +50 °C (+32 °F < Ta < +122 °F) for Series B Chassis	ControlLogix 5590 Standard Controllers: 1756-A4, 1756-A4K, 1756-A7, 1756-A7K, 1756-A10, 1756-A10K, 1756-A13, 1756-A13K, 1756-A17, 1756-A17K 0 °C < Ta < +60 °C (+32 °F < Ta < +140 °F) for Series C chassis 0 °C < Ta < +50 °C (+32 °F < Ta < +122 °F) for Series B ControlLogix-XT 5590 Controllers and ControlLogix-XT 5590 Process Controllers 1756-A7XT, 1756-A10XT, Series C 1756-A7ZXT, 1756-A10ZXT -25 °C < Ta < +70 °C (-13 °F < Ta < +158 °F)
Programming Software	Studio 5000 Logix Designer® Application Version 28.00.00 or later	Studio 5000 Logix Designer Application Version 38.00.00 or later

GuardLogix Controllers Minimum Requirements

Requirement, Minimum	GuardLogix 5580 Controller	ControlLogix 5590 Controllers (when safety-enabled)
Chassis	1756-A4, 1756-A4K, 1756-A7, 1756-A7K, 1756-A10, 1756-A10K, 1756-A13, 1756-A13K, 1756-A17, 1756-A17K Operating in SIL 2/PL d Configuration: 0 °C < Ta < +60 °C (+32 °F < Ta < +140 °F) for Series C Chassis 0 °C < Ta < +50 °C (+32 °F < Ta < +122 °F) for Series B Chassis Note: If operating above +55 °C (+131 °F), modules greater than 6.2 W shall not be installed in slots adjacent to the controller. Operating in SIL 3/PL e Configuration: 0 °C < Ta < +60 °C (+32 °F < Ta < +140 °F) for Series C Chassis 0 °C < Ta < +50 °C (+32 °F < Ta < +122 °F) for Series B Chassis	ControlLogix 5590 Standard Controllers: 1756-A4, 1756-A4K, 1756-A7, 1756-A7K, 1756-A10, 1756-A10K, 1756-A13, 1756-A13K, 1756-A17, 1756-A17K 0 °C < Ta < +60 °C (+32 °F < Ta < +140 °F) for Series C chassis 0 °C < Ta < +50 °C (+32 °F < Ta < +122 °F) for Series B ControlLogix-XT 5590 Controllers and ControlLogix-XT 5590 Process Controllers 1756-A7XT, 1756-A10XT, Series C 1756-A7ZXT, 1756-A10ZXT -25 °C < Ta < +70 °C (-13 °F < Ta < +158 °F)
Programming Software	Studio 5000 Logix Designer Application Version 31.00.00 or later	Studio 5000 Logix Designer Application Version 38.00.00 or later

Product Comparison

This section compares:

- ControlLogix 5590 controllers to ControlLogix 5580 controllers
- ControlLogix 5590 (safety-enabled) controllers to GuardLogix 5580 controllers

ControlLogix 5580 and ControlLogix 5590 Controllers

The 5580 controllers and 5590 controllers operate similarly, with these differences. The following table applies when safety is disabled on the 5590 controllers.

Attribute	ControlLogix 5580 Controllers	ControlLogix 5590 Controllers
Controller Memory	<ul style="list-style-type: none"> • 1756-L81E, 1756-L81E-NSE, 1756-L81EXT, 1756-L81EP: 3 MB • 1756-L82E, 1756-L82E-NSE, 1756-L82EXT: 5 MB • 1756-L83E, 1756-L83E-NSE, 1756-L83EXT, 1756-L83EP: 10 MB • 1756-L84E, 1756-L84E-NSE, 1756-L84EXT: 20 MB • 1756-L85E, 1756-L85E-NSE, 1756-L85EXT, 1756-L85EP: 40 MB 	<ul style="list-style-type: none"> • 1756-L902TS, 1756-L902TSXT: 2 MB standard + 2 MB safety • 1756-L905TS, 1756-L905TSXT, 1756-L905TPSXT: 5 MB standard + 5 MB safety • 1756-L908TS, 1756-L908TSXT: 8 MB standard + 8 MB safety • 1756-L915TS, 1756-L915TSXT, 1756-L915TPSXT: 15 MB standard + 12 MB safety • 1756-L925TS, 1756-L925TSXT: 25 MB standard + 12 MB safety • 1756-L950TS, 1756-L950TSXT, 1756-L950TPSXT: 50 MB standard + 12 MB safety • 1756-L980TS, 1756-L980TSXT, 1756-L980TPSXT: 80 MB standard + 12 MB safety
Remote I/O modules supported	<ul style="list-style-type: none"> • 5094 FLEX 5000[®] I/O⁽¹⁾ • 5069 Compact 5000[®] I/O⁽²⁾ • 5034 PointMax[™] I/O⁽³⁾ • 5032 ArmorBlock 5000[®] I/O⁽⁴⁾ • 5015 FLEXHA 5000[™] I/O⁽⁴⁾ • 1794 FLEX[™] I/O • 1769 Compact I/O[™] • 1756 ControlLogix I/O • 1734 POINT I/O[™] • 1732E ArmorBlock[®] • 1715 Redundant I/O 	<ul style="list-style-type: none"> • 5094 FLEX 5000 I/O • 5069 Compact 5000 I/O • 5034 PointMax I/O • 5032 ArmorBlock 5000 I/O • 5015 FLEXHA 5000 I/O • 1794 FLEX I/O • 1769 Compact I/O • 1756 ControlLogix I/O • 1734 POINT I/O • 1732E ArmorBlock I/O • 1715 Redundant I/O
Ethernet performance	10 Mbps/100 Mbps/1000 Mbps	10 Mbps/100 Mbps/1000 Mbps
EtherNet/IP modes	Not supported	<ul style="list-style-type: none"> • DLR/Linear • Dual-IP
EtherNet/IP nodes supported, max	<p>Logix Designer application, version 28:</p> <ul style="list-style-type: none"> • 1756-L83E: 100 • 1756-L85E: 300⁽⁵⁾ <p>Logix Designer application, version 29:</p> <ul style="list-style-type: none"> • 1756-L81E: 60 • 1756-L82E: 80 • 1756-L83E: 100 • 1756-L84E: 150 • 1756-L85E: 300⁽⁵⁾ <p>Logix Designer application, version 30 or later:</p> <ul style="list-style-type: none"> • 1756-L81E, 1756: 100 • 1756-L82E: 175 • 1756-L83E: 250 • 1756-L84E: 250 • 1756-L85E: 300⁽⁵⁾ <p>Logix Designer application, version 33 or later:</p> <ul style="list-style-type: none"> • 1756-L81E-NSE, 1756-L81EXT, 1756-L81EP: 100 • 1756-L82E-NSE, 1756-L82EXT: 175 • 1756-L83E-NSE, 1756-L83EXT, 1756-L83EP: 250 • 1756-L84E-NSE, 1756-L84EXT: 250 • 1756-L85E-NSE, 1756-L85EXT, 1756-L85EP: 300⁽⁵⁾ 	<ul style="list-style-type: none"> • 1756-L902TS, 1756-L902TSXT: 30 • 1756-L905TS, 1756-L905TSXT, 1756-L905TPSXT: 100 • 1756-L908TS, 1756-L908TSXT: 200 • 1756-L915TS, 1756-L915TSXT, 1756-L915TPSXT: 300 • 1756-L925TS, 1756-L925TSXT: 400 • 1756-L950TS, 1756-L950TSXT, 1756-L950TPSXT: 500 • 1756-L980TS, 1756-L980TSXT, 1756-L980TPSXT: 600⁽⁵⁾

Attribute	ControlLogix 5580 Controllers	ControlLogix 5590 Controllers
I/O capacity (Class 0/1) - packets/second ⁽⁶⁾⁽⁷⁾	<ul style="list-style-type: none"> • 128,000 without CIP Security™ • 40,000 with integrity • 20,000 with integrity and confidentiality 	<ul style="list-style-type: none"> • 164,000 without CIP Security • 60,000 with integrity • 30,000 with integrity and confidentiality
Message rate capacity HMI/MSG (Class 3) - messages/second ⁽⁶⁾⁽⁷⁾		
front port	<ul style="list-style-type: none"> • 2000 without CIP Security • 1500 with integrity • 900 with integrity and confidentiality 	<ul style="list-style-type: none"> • 4000 without CIP Security • 3000 with integrity • 2700 with integrity and confidentiality
backplane ⁽⁸⁾	<ul style="list-style-type: none"> • 4000 via local communication modules 	<ul style="list-style-type: none"> • 7000 via local communication modules
backplane in Logix redundancy ⁽⁸⁾	<ul style="list-style-type: none"> • 2000 via local communication modules 	<ul style="list-style-type: none"> • 2000
Unconnected message buffers	320 incoming buffers 320 outgoing buffers	448 incoming buffers 448 outgoing buffers
Concurrent cached message instructions in the running state	256 dedicated buffers	384 dedicated buffers
HMI and Messaging (Class 3)	512 dedicated messages (256 incoming messages and 256 outgoing messages)	768 dedicated messages (384 incoming messages and 384 outgoing messages)
Integrated motion	<ul style="list-style-type: none"> • EtherNet/IP network • SERCOS interface ⁽²⁾ • Analog options (encoder input, LDT input, SSI input) ⁽²⁾ 	<ul style="list-style-type: none"> • EtherNet/IP network • SERCOS interface • Analog options (encoder input, LDT input, SSI input)
Motion axes	256, any combination of these supported axis types: <ul style="list-style-type: none"> • CIP • Consumed • Virtual • Position loop drives 	512, any combination of these supported axis types: <ul style="list-style-type: none"> • CIP • Consumed • Virtual • Position loop drives
Axes/ms over backplane	---	---
Axes/ms over EtherNet/IP port	20/ms when you use the built-in EtherNet/IP port at 1 Gbps. For fastest motion performance, connect motion drives to the embedded EtherNet/IP port.	120 axes in 4 ms 256 axes in 12 ms 512 axes in 26 ms For fastest motion performance, connect motion drives to the embedded EtherNet/IP port.
Front Port Crossload	—	Full support (used in redundancy applications)
Voltage and current ratings	1.2 A @ 5.1V DC 5.0 mA @ 1.2V DC	1.2 A @ 5.1V DC 5.0 mA @ 1.2V DC
Energy storage module	Embedded in controller, nonremovable	Embedded in controller, nonremovable
Weight, approx	0.394 kg (.868 lb)	0.394 kg (.868 lb)
Wire category ⁽⁹⁾	3 - on USB port 2 - on Ethernet port	3 - on USB port 2 - on Ethernet ports
Wire size	Ethernet cabling and installation according to IEC 61918 and IEC 61784-5-2	Ethernet cabling and installation according to IEC 61918 and IEC 61784-5-2 ⁽¹⁰⁾
Reset Button	<ul style="list-style-type: none"> • A stage 1 reset clears the user application program and memory, retains the IP address and all network settings. • A stage 2 reset returns the controller to out-of-box settings (including firmware), and clears all network settings. 	<ul style="list-style-type: none"> • A stage 1 reset clears the application program and memory, retains the IP address and all network settings. • A stage 2 reset returns the controller to out-of-box settings (including firmware), and clears all network settings.

(1) With Studio 5000 Logix Designer application, version 32.00.00 or later.
(2) With Studio 5000 Logix Designer application, version 31.00.00 or later.
(3) With Studio 5000 Logix Designer, application, version 36.00.00 or later, applications.
(4) With Studio 5000 Logix Designer, application, version 35.00.00 or later, applications.
(5) This is the recommended maximum. Additional EtherNet/IP nodes may be possible depending on remaining controller resources.
(6) I/O numbers are maximums; they assume no HMI/MSG. HMI/MSG numbers are maximums, they assume no I/O. Maximums assume that the processor is the target, not the originator. Packet rates vary depending on packet size. For more details, see Troubleshoot EtherNet/IP Application Technique, publication [ENET-AT003](#), and the EDS file for a specific catalog number.
(7) For information on integrity and confidentiality, see the CIP Security with Rockwell Automation Products Application Technique, publication [SECURE-AT001](#).
(8) Controller performance not impacted by CIP Security.
(9) Use this conductor category information for planning conductor routing. See the Industrial Automation Wiring and Grounding Guidelines, publication [1770-4.1](#).
(10) If the operating temperature exceeds 60 °C (140 °F), the maximum supported cable length is 20 m (65 ft).

GuardLogix 5580 and Safety-enabled ControlLogix 5590 Controllers

The GuardLogix 5580 controllers operate similarly to the 5590 controllers, with some differences. Remember, to use 5590 controllers in safety applications, the controller must be safety-enabled. They are safety-enabled by default.

Attribute	GuardLogix 5580 Controller	ControlLogix 5590 Controllers (safety-enabled)
Instruction-based alarms (ALMA, ALMD)	Yes	Yes
Tag-based alarms	Yes	Yes
PanelView™ 5000	Full support	Full support
User and Safety Memory	<ul style="list-style-type: none"> 1756-L81ES, 1756-L81EXTS: 3 MB + 1.5 MB Safety 1756-L82ES, 1756-L82EXTS: 5 MB + 2.5 MB Safety 1756-L83ES, 1756-L83EXTS: 10 MB + 5.0 MB Safety 1756-L84ES, 1756-L84EXTS: 20 MB + 6.0 MB Safety 	<ul style="list-style-type: none"> 1756-L902TS, 1756-L902TSXT: 2 MB standard + 2 MB safety 1756-L905TS, 1756-L905TSXT, 1756-L905TPSXT: 5 MB standard + 5 MB safety 1756-L908TS, 1756-L908TSXT: 8 MB standard + 8 MB safety 1756-L915TS, 1756-L915TSXT, 1756-L915TPSXT: 15 MB standard + 12 MB safety 1756-L925TS, 1756-L925TSXT: 25 MB standard + 12 MB safety 1756-L950TS, 1756-L950TSXT, 1756-L950TPSXT: 50 MB standard + 12 MB safety 1756-L980TS, 1756-L980TSXT, 1756-L980TPSXT: 80 MB standard + 12 MB safety
I/O Memory	Not applicable ⁽¹⁾	Not applicable ⁽¹⁾
Remote I/O modules supported	<ul style="list-style-type: none"> 5094 FLEX 5000 I/O⁽²⁾ 5069 Compact 5000⁽³⁾ 5034 PointMax I/O⁽⁴⁾ 5032 ArmorBlock 5000⁽⁵⁾ 5015 FLEXHA 5000 I/O⁽⁵⁾ 1794 FLEX I/O 1769 Compact I/O 1756 ControlLogix I/O 1734 POINT I/O 1734 POINT Guard I/O™ 1732E ArmorBlock® 1715 Redundant I/O 	<ul style="list-style-type: none"> 5094 FLEX 5000 I/O 5069 Compact 5000 5034 PointMax I/O 5032 ArmorBlock 5000 5015 FLEXHA 5000 I/O 1794 FLEX I/O 1769 Compact I/O 1756 ControlLogix I/O 1734 POINT I/O 1734 POINT Guard I/O 1732E ArmorBlock 1715 Redundant I/O
1756 ControlLogix Digital Safety I/O modules supported	Full support with Studio 5000 Logix Designer Application, version 32.00.00 or later, with Add-on Profile.	Full support
Embedded Ethernet	10/100/1000 Mbps	10/100/1000 Mbps
EtherNet/IP nodes supported, max	<ul style="list-style-type: none"> 1756-L81ES, 1756-L81EXTS: 100 1756-L82ES, 1756-L82EXTS: 175 1756-L83ES, 1756-L83EXTS: 250 1756-L84ES, 1756-L84EXTS: 250 	Logix Designer application, version 38 or later: <ul style="list-style-type: none"> 1756-L902TS, 1756-L902TSXT: 30 1756-L905TS, 1756-L905TSXT, 1756-L905TPSXT: 100 1756-L908TS, 1756-L908TSXT: 200 1756-L915TS, 1756-L915TSXT, 1756-L915TPSXT: 300 1756-L925TS, 1756-L925TSXT: 400 1756-L950TS, 1756-L950TSXT, 1756-L950TPSXT: 500 1756-L980TS, 1756-L980TSXT, 1756-L980TPSXT: 600⁽⁶⁾
I/O Capacity (Class 0/1) - packets/second ⁽⁷⁾⁽⁸⁾	<ul style="list-style-type: none"> 128,000 without CIP Security™ 40,000 with integrity 20,000 with integrity and confidentiality 	<ul style="list-style-type: none"> 164,000 without CIP Security 60,000 with integrity 30,000 with integrity and confidentiality
Message Rate Capacity HMI/MSG (Class 3) - messages/second ⁽⁷⁾⁽⁸⁾		
front port without safety partner	<ul style="list-style-type: none"> 2000 without CIP Security 1500 with integrity 900 with integrity and confidentiality 	<ul style="list-style-type: none"> 4000 without CIP Security 3000 with integrity 2700 with integrity and confidentiality
front port with safety partner	<ul style="list-style-type: none"> 1000 without CIP Security 750 with integrity 450 with integrity and confidentiality 	<ul style="list-style-type: none"> 2000 without CIP Security 1500 with integrity 900 with integrity and confidentiality
backplane without safety partner ⁽⁹⁾	• 4000 via local communication modules	• 7000 via local communication modules
backplane with safety partner ⁽⁹⁾	• 2000 via local communication modules	• 2000 via local communication modules
backplane in Logix redundancy ⁽⁹⁾	• 2000 via local communication modules	• 2000 via local communication modules
Unconnected message buffers	320 incoming unconnected messages 448 incoming unconnected messages	320 incoming unconnected messages 448 incoming unconnected messages

Attribute	GuardLogix 5580 Controller	ControlLogix 5590 Controllers (safety-enabled)
Concurrent cached message instructions in the running state	256 dedicated buffers	384 dedicated buffers
HMI and Messaging (Class 3)	512 dedicated messages (256 incoming messages and 256 outgoing messages)	768 dedicated messages (384 incoming messages and 384 outgoing messages)
Integrated motion	<ul style="list-style-type: none"> EtherNet/IP network SERCOS interface Analog options (encoder input, LDT input, SSI input) 	<ul style="list-style-type: none"> EtherNet/IP network SERCOS interface Analog options (encoder input, LDT input, SSI input)
Drive Safety Instructions with Kinetix® 5700 ERS4 Drives	Yes	Yes
Networked Safe Torque Off for Drives (CIP Mode/IO Mode)	Full support	Full support
Networked Safe Torque Off for Kinetix® (CIP Mode)	Full support	Full support
Motion axes	256, any combination of these supported axis types: <ul style="list-style-type: none"> CIP Consumed Virtual Position loop drives 	512, any combination of these supported axis types: <ul style="list-style-type: none"> CIP Consumed Virtual Position loop drives
Axes/ms over backplane	19	120 axes in 4 ms 256 axes in 12 ms 512 axes in 26 ms
Axes/ms over EtherNet/IP port	20/ms when you use the built-in EtherNet/IP port at 1 Gbps. Rockwell Automation recommends that you use the built-in EtherNet/IP port for high-performance motion applications.	---
Front Port Crossload	—	Full support (used in redundancy applications) ⁽¹⁰⁾
Voltage and current ratings	1.2 A @ 5.1V DC 5.0 mA @ 1.2V DC	1.2 A @ 5.1V DC 5.0 mA @ 1.2V DC
Energy storage module	Embedded in controller, nonremovable	Embedded in controller, nonremovable
Weight, approx	0.394 kg (.868 lb)	
Wire category ⁽¹¹⁾	3 - on USB port 2 - on Ethernet port	3 - on USB port 2 - on Ethernet ports
Wire size	Ethernet cabling and installation according to IEC 61918 and IEC 61784-5-2	Ethernet cabling and installation according to IEC 61918 and IEC 61784-5-2 ⁽¹²⁾
Reset Button	<ul style="list-style-type: none"> A stage 1 reset clears the user application program and memory, retains the IP address and all network settings. A controller stage 2 reset returns the controller to out-of-box settings (including firmware), and clears all network settings. On a GuardLogix 5580 controller, the stage 2 reset also clears safety settings and the safety signature/safety locked state. The Safety Partner reset returns the 1756-L8SP Safety Partner to the out-of-box settings (including firmware). In a SIL 3 application, when you reset the GuardLogix Controller you must also reset the 1756-L8SP Safety Partner. 	<ul style="list-style-type: none"> A stage 1 reset clears the user application program and memory, retains the IP address and all network settings. A controller stage 2 reset returns the controller to out-of-box settings (including firmware), and clears all network settings. On a safety-enabled controller, the controller stage 2 reset also clears safety settings and the safety signature/safety locked state. The Safety Partner reset returns the 1756-L9SP Safety Partner to the out-of-box settings (including firmware). In a SIL 3 application, when you reset the safety-enabled controller you must also reset the 1756-L9SP Safety Partner.

(1) The 5590 and 5580 controllers allocate memory as needed, so there is no dedicated I/O memory space.

(2) With Studio 5000 Logix Designer application, version 32.00.00 or later.

(3) With Studio 5000 Logix Designer application, version 31.00.00 or later.

(4) With Studio 5000 Logix Designer application, version 36.00.00 and later.

(5) With Studio 5000 Logix Designer application, version 35.00.00 and later.

(6) This is the recommended maximum. Additional EtherNet/IP nodes may be possible depending on remaining controller resources.

(7) I/O numbers are maximums; they assume no HMI/MSG. HMI/MSG numbers are maximums, they assume no I/O. Packet rates vary depending on packet size. For more details, see Troubleshoot EtherNet/IP Application Technique, publication [ENET-AT003](#), and the EDS file for a specific catalog number.

(8) For information on integrity and confidentiality, see the CIP Security with Rockwell Automation Products Application Technique, publication [SECURE-AT001](#).

(9) Controller performance not impacted by CIP Security.

(10) You still must use the 1756-RM3 Redundancy module when you use the Front Port Crossload.

(11) Use this conductor category information for planning conductor routing. See the Industrial Automation Wiring and Grounding Guidelines, publication [1770-4.1](#).

(12) If the operating temperature exceeds 60 °C (140 °F), the maximum supported cable length is 20 m (65 ft).

Controller Dimensions

This section shows controller dimensions.

ControlLogix 5580 Dimensions

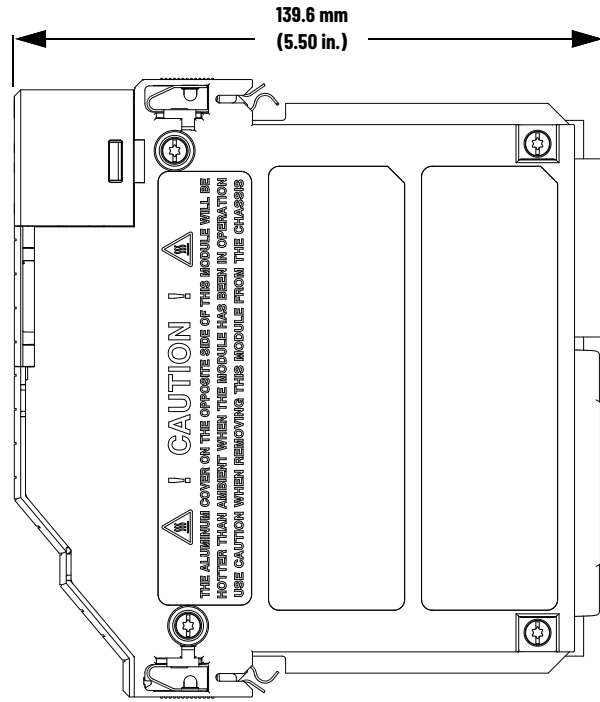
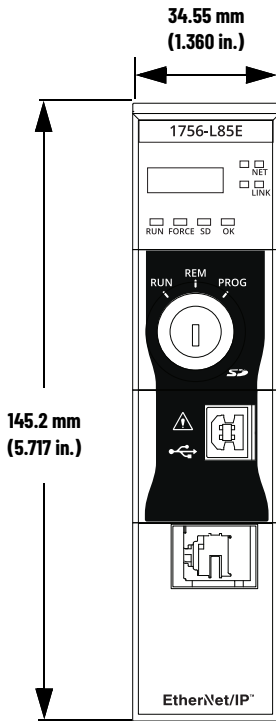

GuardLogix 5580 Dimensions

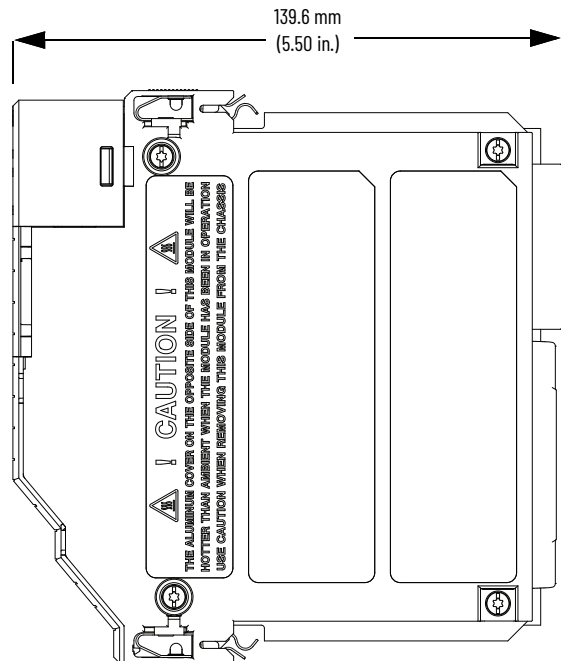
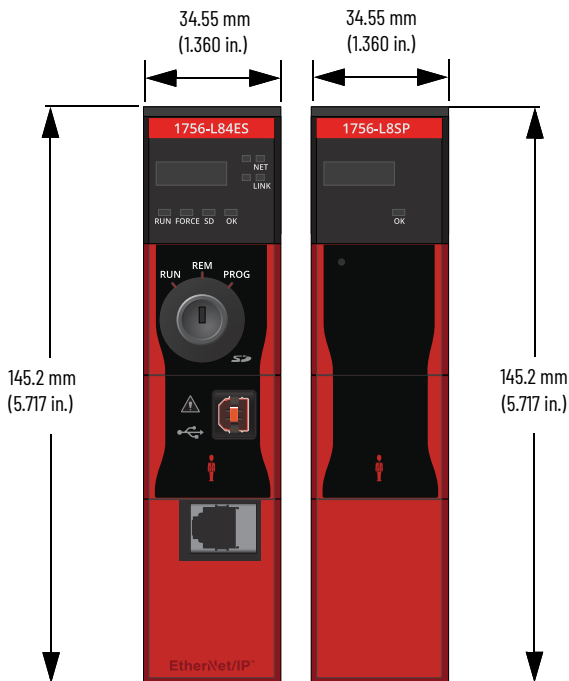

ControlLogix 5590 Dimensions

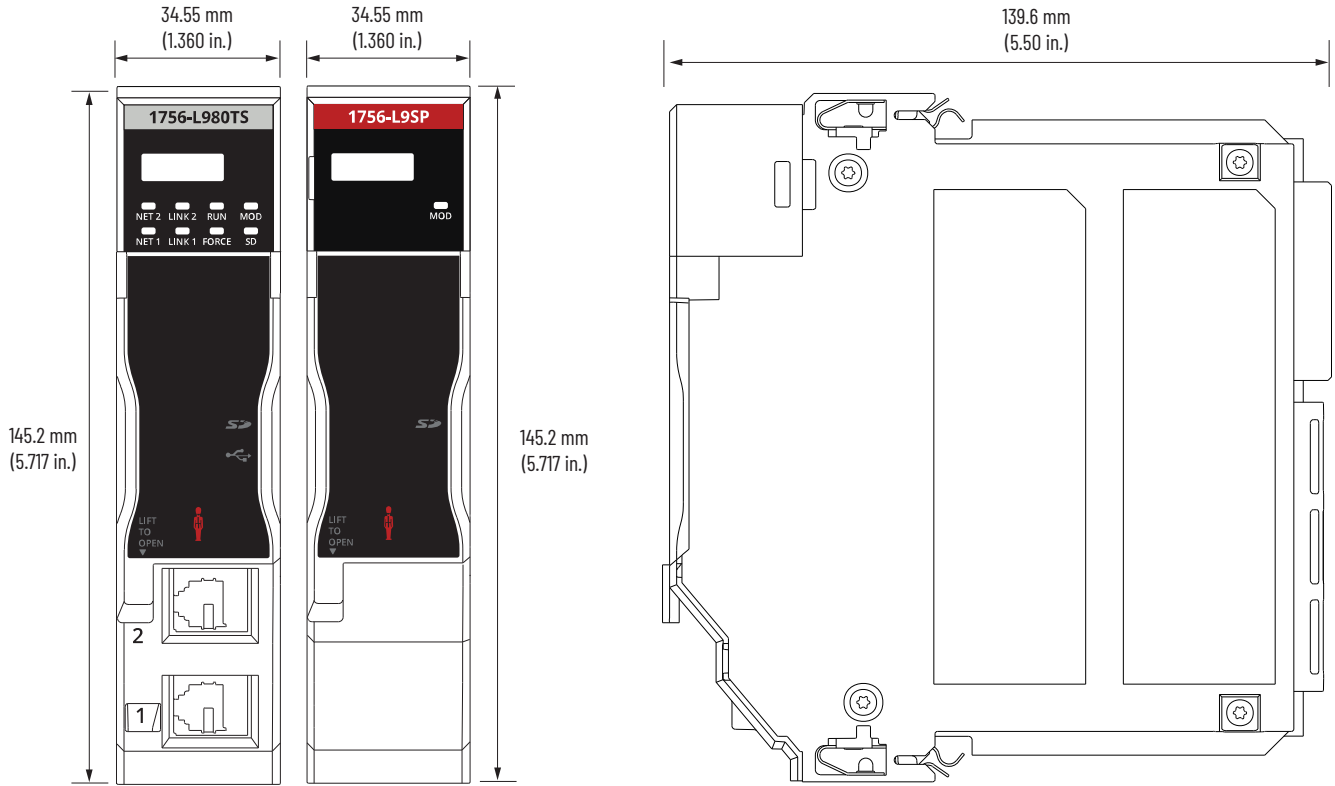

Connectors and Status Indicators

This section shows the front plate differences. For more information on the status indicators and reset button, see Chapter 9, [Diagnostics and Status Indicators with ControlLogix Systems on page 179](#).

ControlLogix 5580

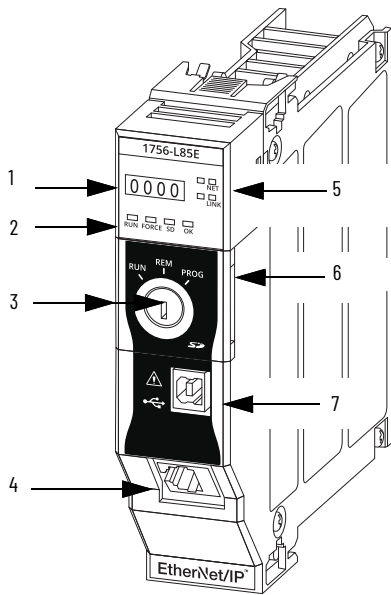

Item	Description
1	4-character Display
2	Status Indicators
3	REM RUN PROG mode switch
4	Ethernet Port
5	Ethernet Status Indicators
6	SD Card slot and Reset button are behind the door. ⁽¹⁾
7	USB Port

(1) First remove the key, then open the door from right to left.

ControlLogix 5590

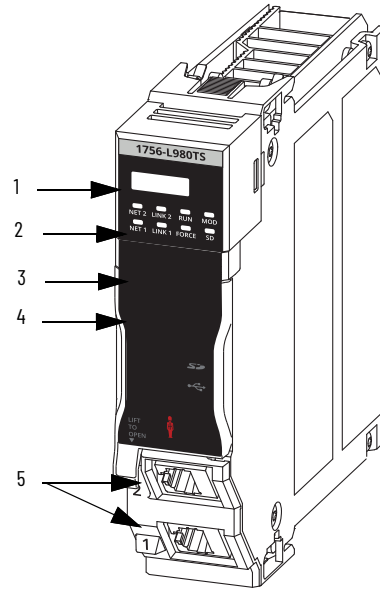

Item	Description
1	4-character Display
2	Status Indicators
3	Door ⁽¹⁾
4	The following are behind the door: <ul style="list-style-type: none"> • Reset button • QR Code • REM RUN PROG mode switch • microSD™ card slot • USB-C port
5	Ethernet Ports 1 and 2

(1) The door opens from bottom to top.

GuardLogix 5580 and Safety Partner

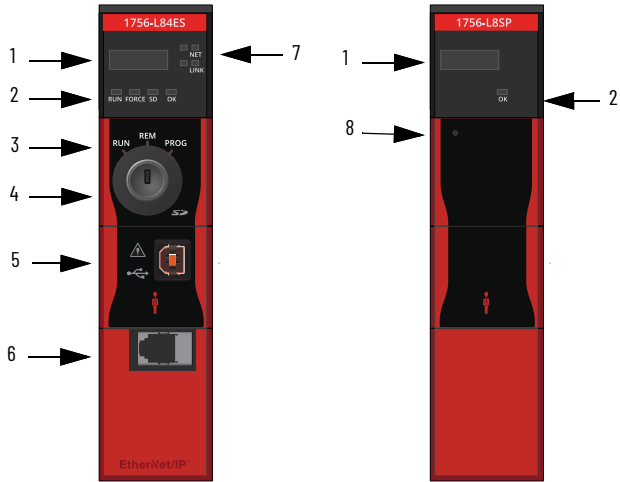

Item	Description
1	4-character display
2	Status Indicators
3	REM RUN PROG mode switch
4	SD card slot and Reset Button behind the door ⁽¹⁾
5	USB Port
6	Ethernet Port
7	Ethernet Status Indicators
8	Safety Partner Reset Button

(1) First remove the key, then open the door from right to left.

ControlLogix 5590 Safety Partner

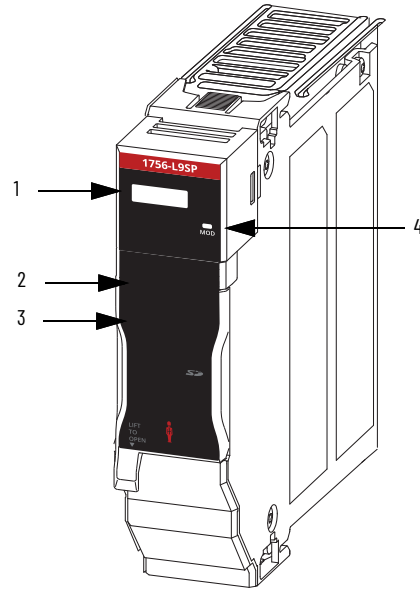

Item	Description
1	4-character Display
2	Door ⁽¹⁾
3	The following are behind the door: <ul style="list-style-type: none"> • Reset button • QR Code • microSD card slot
4	MOD status indicator

(1) The door opens from top to bottom.

Configure the Controller

New Project Dialog Box

When you create a project with a 5590 controller, the Module Definition dialog box appears. The dialog box provides standard controller settings, along with additional security settings. The information that is entered in this dialog box displays on the Controller Properties General tab and Security tab.

The screenshot shows the 'New Project' dialog box for a 1756-L902TS ControlLogix 5590 Controller. The dialog is titled 'New Project' and contains the following fields and options:

- Revision:** 38
- Chassis:** 1756-A17 17-Slot ControlLogix Chassis
- Slot:** 0. A note indicates: 'Project default will be SIL2/PLd with no safety partner.'
- Security Authority:** No Protection. A checkbox option is present: 'Use only the selected Security Authority for authentication and authorization'.
- Secure With:** Logical Name <Controller Name> (selected). A radio button option is present: 'Permission Set'.
- Description:** A text input field.
- Redundancy:** Enable

At the bottom of the dialog, there are four buttons: Cancel, Back, Next, and Finish.

Controller Properties

This table compares the Controller Properties tab for 5580 and 5590 controllers.

Controller Properties Tab	Comments
General	EtherNet/IP Mode parameter is available on 5590 controllers. See General Tab on page 65
Major Faults	Safety Task Major Fault is the same on GuardLogix 5580 controllers and safety-enabled 5590 controllers. It is not available on ControlLogix 5580 controllers. See Major Faults Tab on page 66
Minor Faults	Same functionality
Date/Time	Same functionality
Advanced	Same functionality
SFC Execution	Same functionality
Project	Same functionality
Redundancy	Front Port Crossload is available on 5590 controllers. See Redundancy Tab on page 67
Safety (GuardLogix controllers and 5590 safety-enabled controllers only)	You can set a separate safety network number for each Ethernet port on 5590 controllers. See Safety Tab on page 68 .
Nonvolatile Memory	Same functionality (5580 controllers use an SD card. 5590 controllers use a MicroSD™ card)
Capacity	Capacity and Safety Capacity are shown on safety-enabled 5590 controllers. Only Capacity is available for ControlLogix 5580 controllers. See Capacity Tab on page 69
Internet Protocol	You can configure separate values for each Ethernet port on 5590 controllers. See Internet Protocol Tab on page 70 .
Port Configuration	You can configure separate values for each Ethernet port on 5590 controllers. See Port Configuration Tab on page 71 .
Network	New for 5590 controllers. See Network Tab on page 73 .
Security	Now has additional security parameters. See Security Tab on page 74 .
Alarm Log	Same functionality
OPC UA	The option to enable OPC UA on each Ethernet port is available for 5590 controllers. In this case, EtherNet/IP Mode is Dual-IP.

General Tab

The General tab provides basic information about the project, such as, controller firmware revision, project name, and chassis type.

The EtherNet/IP Mode parameter is available with ControlLogix 5590 controllers but not with 5580 controllers.

Figure 11 - Controller Properties Dialog Box - General Tab

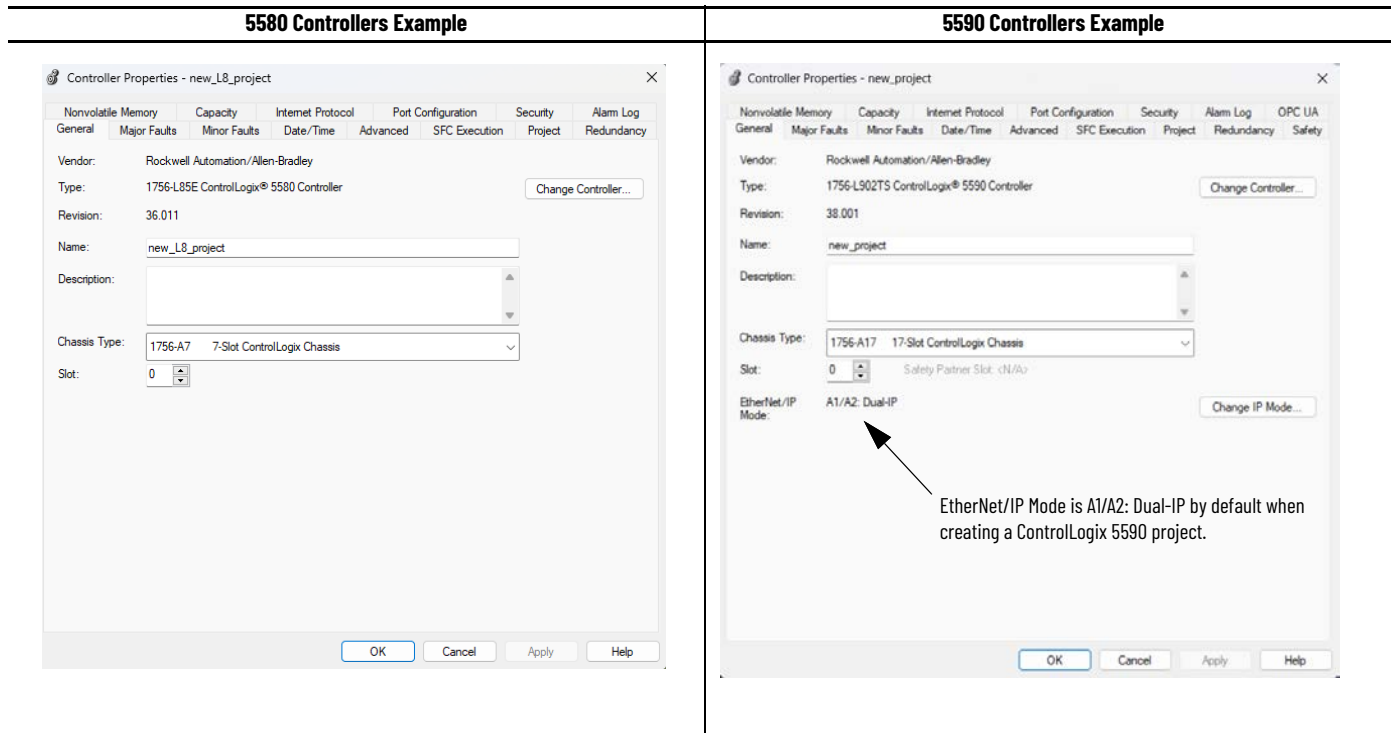

Major Faults Tab

The Major Faults tab provides information about major faults that have occurred on the controller and the option to clear them. The project must be online to use this tab.

With ControlLogix 5590 and GuardLogix 5580 controllers, there is an indication that Safety Task major fault has occurred when the project is online.

Figure 12 - Controller Properties Dialog Box - Redundancy Tab

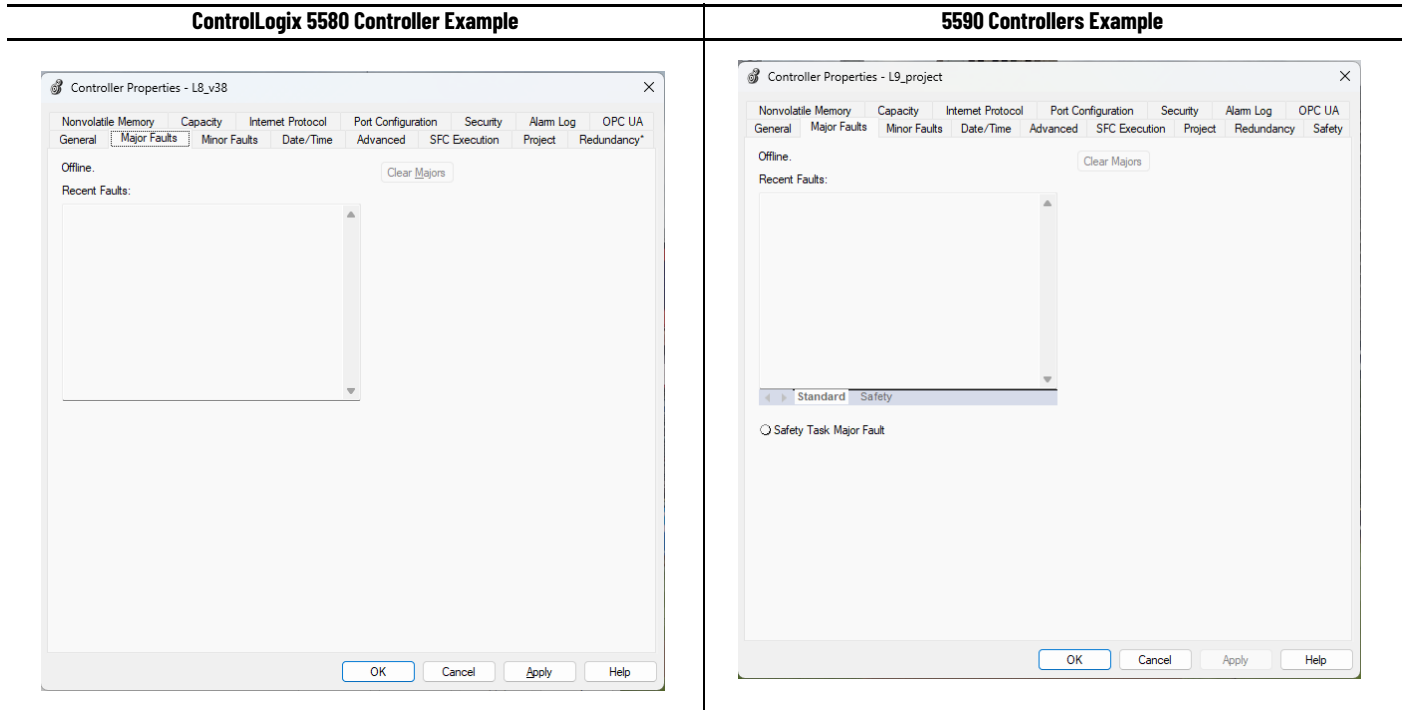

Redundancy Tab

The Redundancy tab lets you configure Redundancy parameters.

You can configure 5590 controllers to use Front Port Crossload. For more information on Front Port Crossload, see [page 132](#).

Figure 13 - Controller Properties Dialog Box - Redundancy Tab

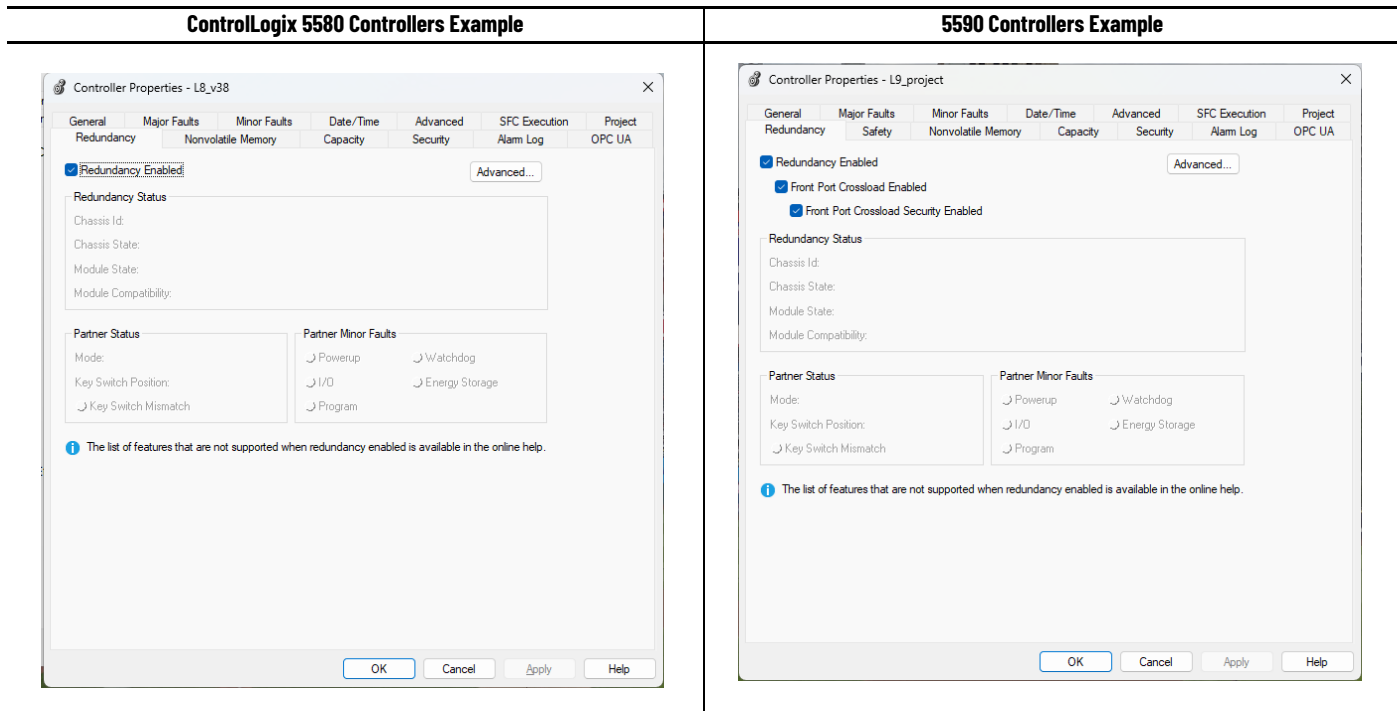

Safety Tab

The Safety tab lets you configure safety parameters based on system conditions. For 5590 controllers, you can set a separate safety network number for each Ethernet port. The option is available when EtherNet/IP Mode is Dual-IP.

Figure 14 - Controller Properties Dialog Box - Safety Tab

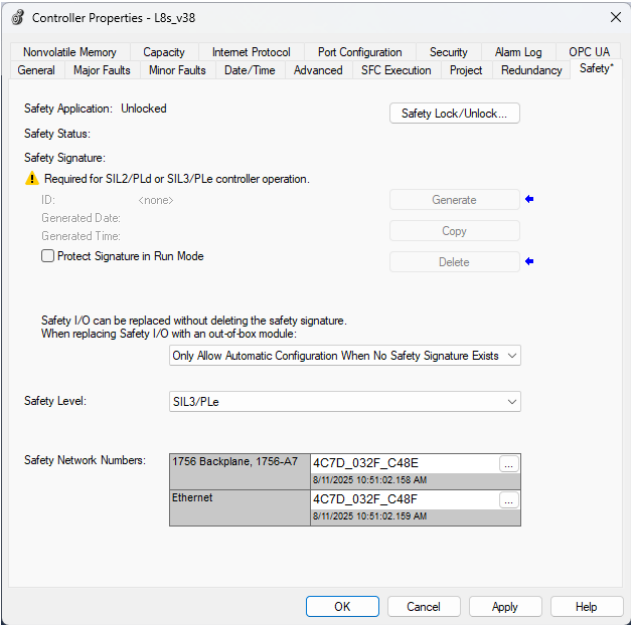
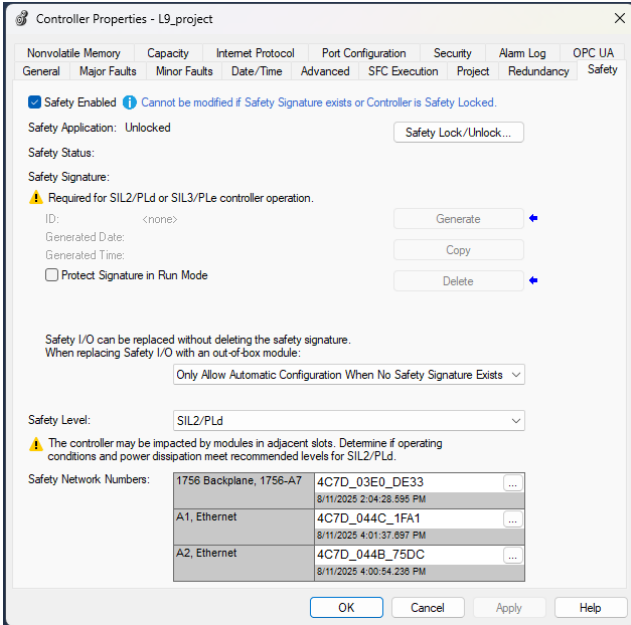
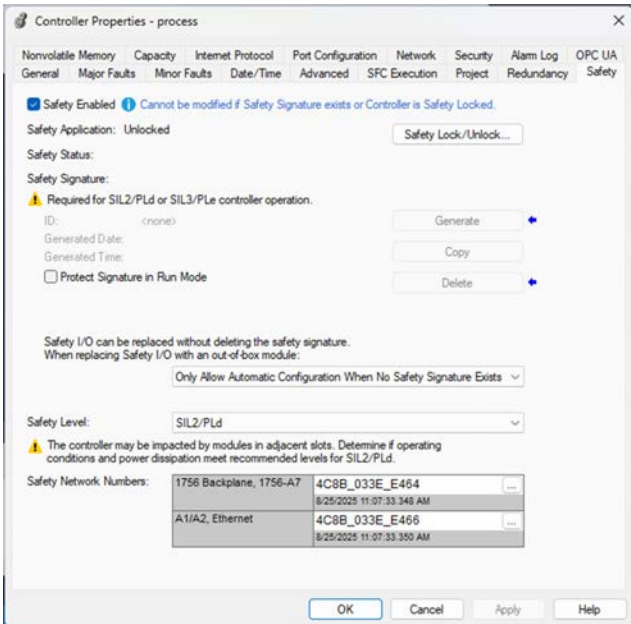
5580 Controllers Example	5590 Controllers Example										
 <p>Controller Properties - L8s_y38</p> <p>Safety Application: Unlocked</p> <p>Safety Status: Unlocked</p> <p>Safety Signature: <none></p> <p>Required for SIL2/PLd or SIL3/PLe controller operation.</p> <p>Safety Level: SIL3/PLe</p> <table border="1"> <tr> <td>1756 Backplane, 1756-A7</td> <td>4C7D_032F_C48E</td> </tr> <tr> <td>Ethernet</td> <td>4C7D_032F_C48F</td> </tr> </table>	1756 Backplane, 1756-A7	4C7D_032F_C48E	Ethernet	4C7D_032F_C48F	<p style="text-align: center;">DualIP Mode</p>  <p>Controller Properties - L9_project</p> <p><input checked="" type="checkbox"/> Safety Enabled</p> <p>Safety Application: Unlocked</p> <p>Safety Status: Unlocked</p> <p>Safety Signature: <none></p> <p>Required for SIL2/PLd or SIL3/PLe controller operation.</p> <p>Safety Level: SIL2/PLd</p> <table border="1"> <tr> <td>1756 Backplane, 1756-A7</td> <td>4C7D_03E0_DE33</td> </tr> <tr> <td>A1, Ethernet</td> <td>4C7D_044C_1FA1</td> </tr> <tr> <td>A2, Ethernet</td> <td>4C7D_044B_75DC</td> </tr> </table>	1756 Backplane, 1756-A7	4C7D_03E0_DE33	A1, Ethernet	4C7D_044C_1FA1	A2, Ethernet	4C7D_044B_75DC
1756 Backplane, 1756-A7	4C7D_032F_C48E										
Ethernet	4C7D_032F_C48F										
1756 Backplane, 1756-A7	4C7D_03E0_DE33										
A1, Ethernet	4C7D_044C_1FA1										
A2, Ethernet	4C7D_044B_75DC										
 <p>Controller Properties - process</p> <p><input checked="" type="checkbox"/> Safety Enabled</p> <p>Safety Application: Unlocked</p> <p>Safety Status: Unlocked</p> <p>Safety Signature: <none></p> <p>Required for SIL2/PLd or SIL3/PLe controller operation.</p> <p>Safety Level: SIL2/PLd</p> <table border="1"> <tr> <td>1756 Backplane, 1756-A7</td> <td>4C8B_033E_E464</td> </tr> <tr> <td>A1/A2, Ethernet</td> <td>4C8B_033E_E466</td> </tr> </table>	1756 Backplane, 1756-A7	4C8B_033E_E464	A1/A2, Ethernet	4C8B_033E_E466							
1756 Backplane, 1756-A7	4C8B_033E_E464										
A1/A2, Ethernet	4C8B_033E_E466										

Capacity Tab

In the Logix Designer application, version 29 or later, the Capacity tab indicates data usage. The tab also shows the number of Ethernet nodes that are used.

- ControlLogix 5580 controllers - One value shows data usage. It combines Data and Logic memory usage and I/O memory usage.
- Safety-enabled 5590 controllers and GuardLogix 5580 controllers - Two values show data usage. One value shows available Data and Logic memory usage and I/O memory usage. The other value shows the Safety memory usage.

IMPORTANT

5590 controllers are safety-enabled by default. If you disable safety, the Capacity tab matches the ControlLogix 5580 controllers Capacity tab:

- If you are converting from a GuardLogix 5580 controller to a 5590 controller, safety is enabled.
- If you are converting from a ControlLogix 5580 controller to a 5590 controller, safety is automatically disabled.

As you change the project, the data values are automatically updated to indicate the estimated memory usage and remaining available memory.

Figure 15 - ControlLogix Controller Properties Dialog Box - Capacity Tab

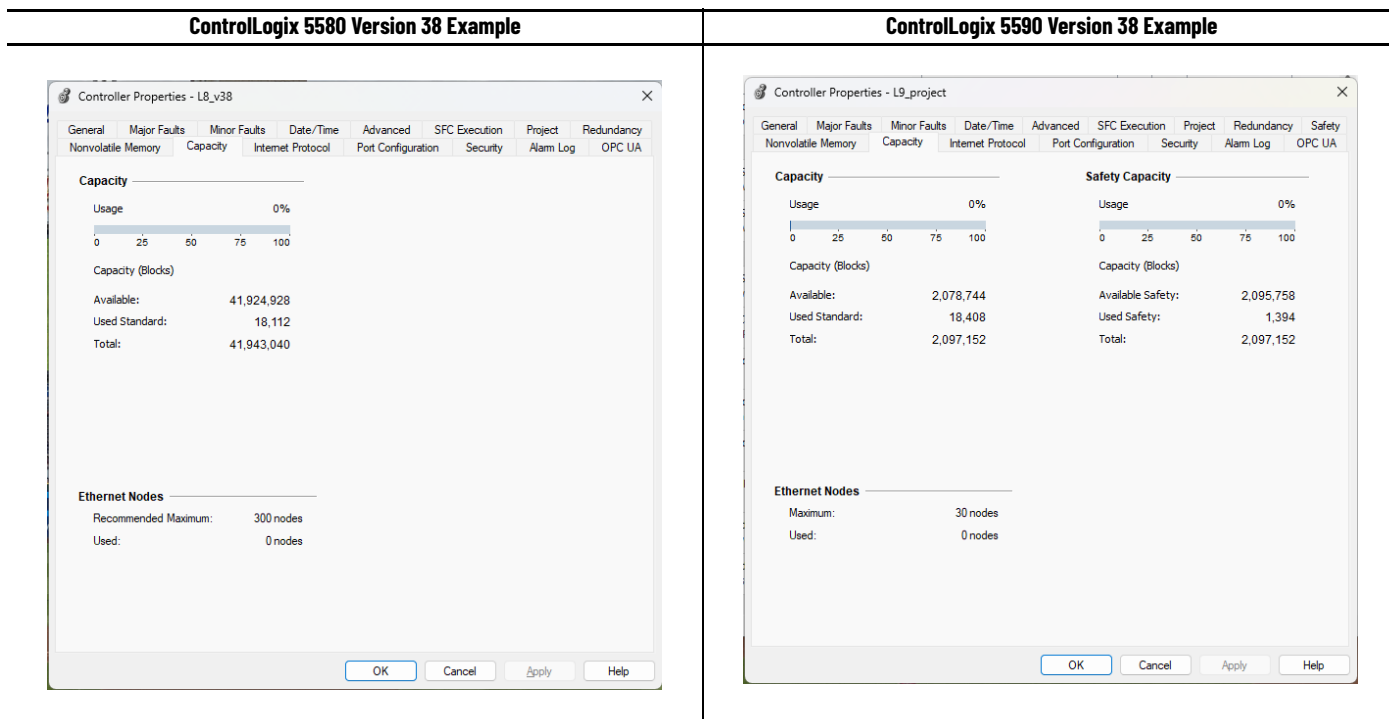

Internet Protocol Tab

When online with a 5590 controller, the Internet Protocol tab lets you configure the IP Settings. These settings are not available offline.

- If EtherNet/IP mode is Dual-IP, you configure the settings for each Ethernet port separately.
- If EtherNet/IP mode is Linear/DLR, you configure one value for setting and it applies to both Ethernet ports as Port A1/A2.

Figure 16 - Controller Properties Dialog Box - Internet Protocol Tab - Online

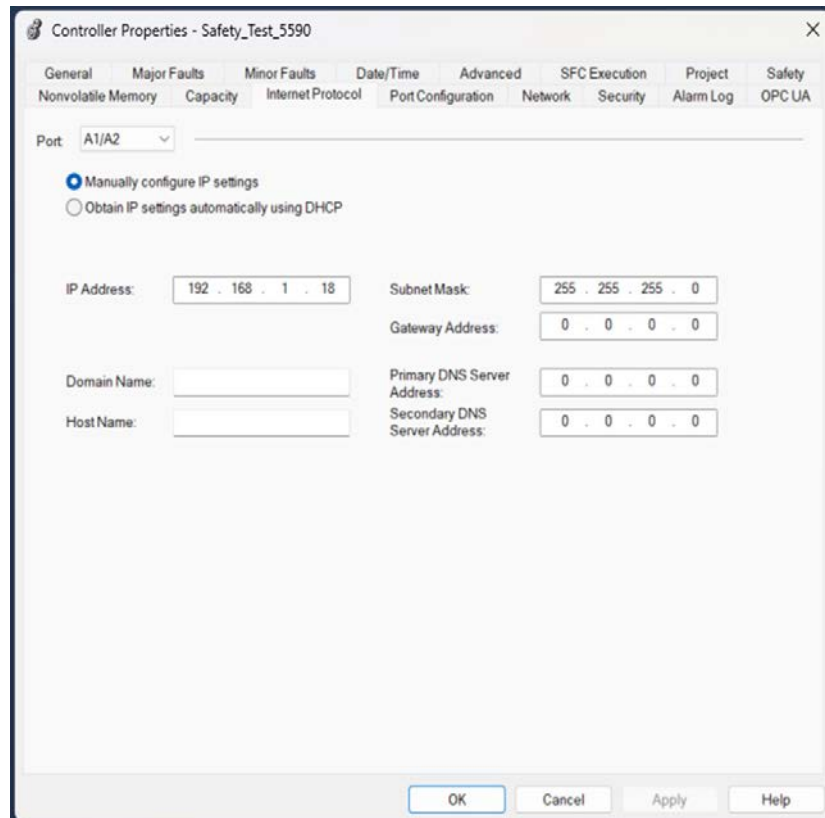

When online, configurable settings include the following:

- Source of IP Settings (DHCP, BOOTP, or manual configuration)
- Physical Module IP Address
- Subnet Mask
- Gateway Address
- Domain Name
- Host Name, Primary DNS Server Address
- Secondary DNS Server Address

Port Configuration Tab

When online, the Port Configuration tab lets you view and configure the Ethernet port settings:

- View Link Status
- Enable/Disable the Ethernet port
- Configure Auto-Negotiate
- Configure Selected Speed up to 1 Gbps (or set to auto-negotiate)
- View Current Speed
- Configure Selected Duplex - 5580 controllers only support full-duplex.
- View Current Duplex
- Access the Port Diagnostics dialog

You can change the Port Configuration parameters without resetting the controller. You configure the settings for each Ethernet port separately.

IMPORTANT When you configure the Ethernet ports, only port 1 connect to enterprise-level networks; it can also connect to device-level networks if necessary.
Port 2 can only connect to device-level networks.

Figure 17 - Controller Properties Dialog Box - Port Configuration Tab

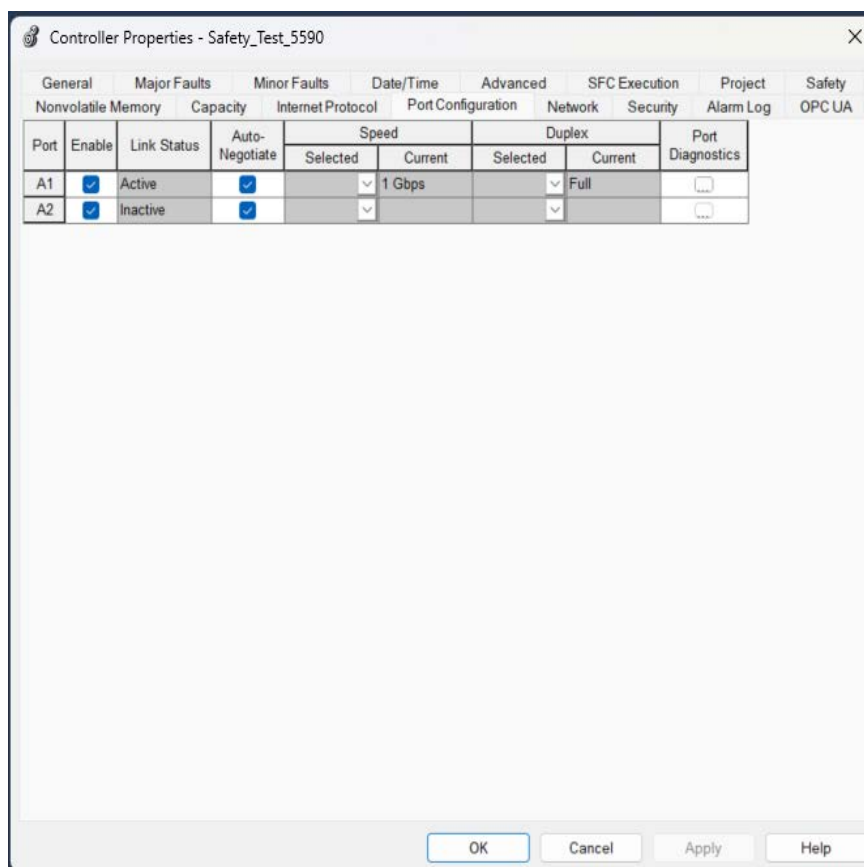

Port Diagnostics

On the Port Configuration category, click the Port Diagnostics button to view information for the Ethernet port.

For parameter descriptions, see the ControlLogix 5590 Controllers User Manual, publication [1756-UM900](#) or the Logix Designer online help.

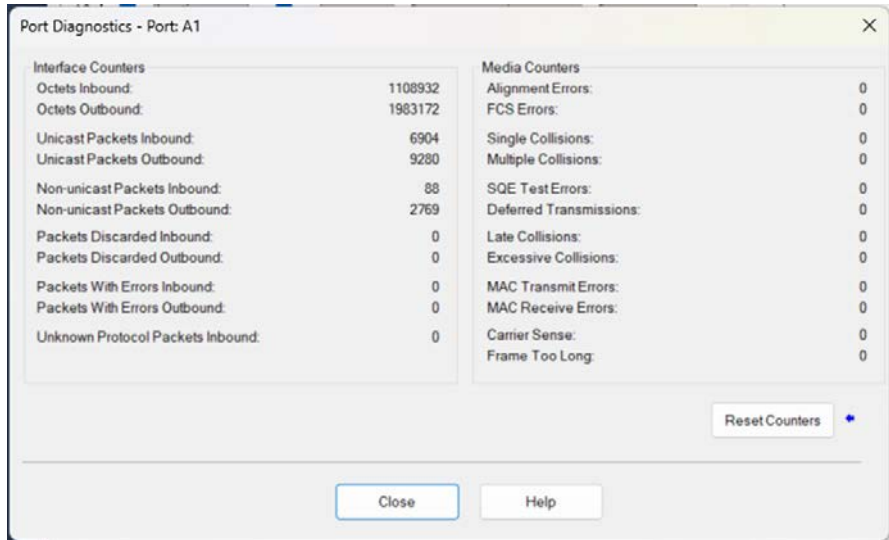

Network Tab

The Network tab is available on 5590 controllers but not 5580 controllers. When online, this tab shows network status and faults, if any exist. It is only available when EtherNet/IP Mode is Linear/DLR.

Figure 18 - Controller Properties Dialog Box - Network Tab

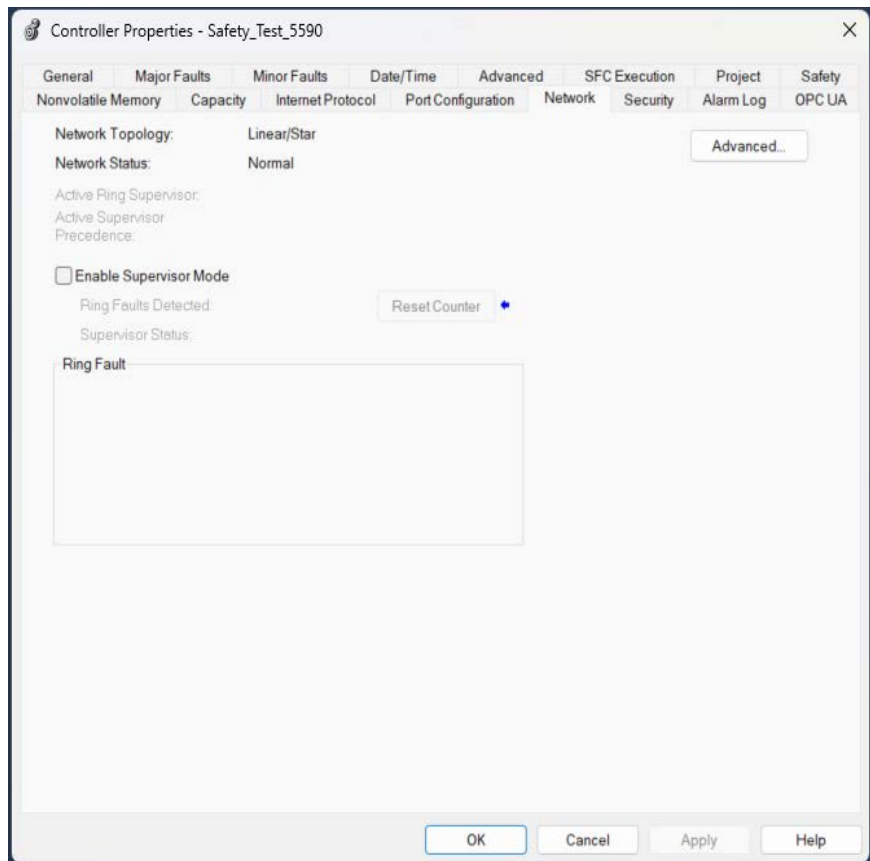

Security Tab

The Security Tab lets you see the controller security settings, for example, the Security Authority choice. Security settings are configured when you create the project.

With the Logix Designer application, version 28 or later, the 5580 controllers support additional parameters in the Security Authority section.

Figure 19 - Controller Properties Dialog Box - Security Tab

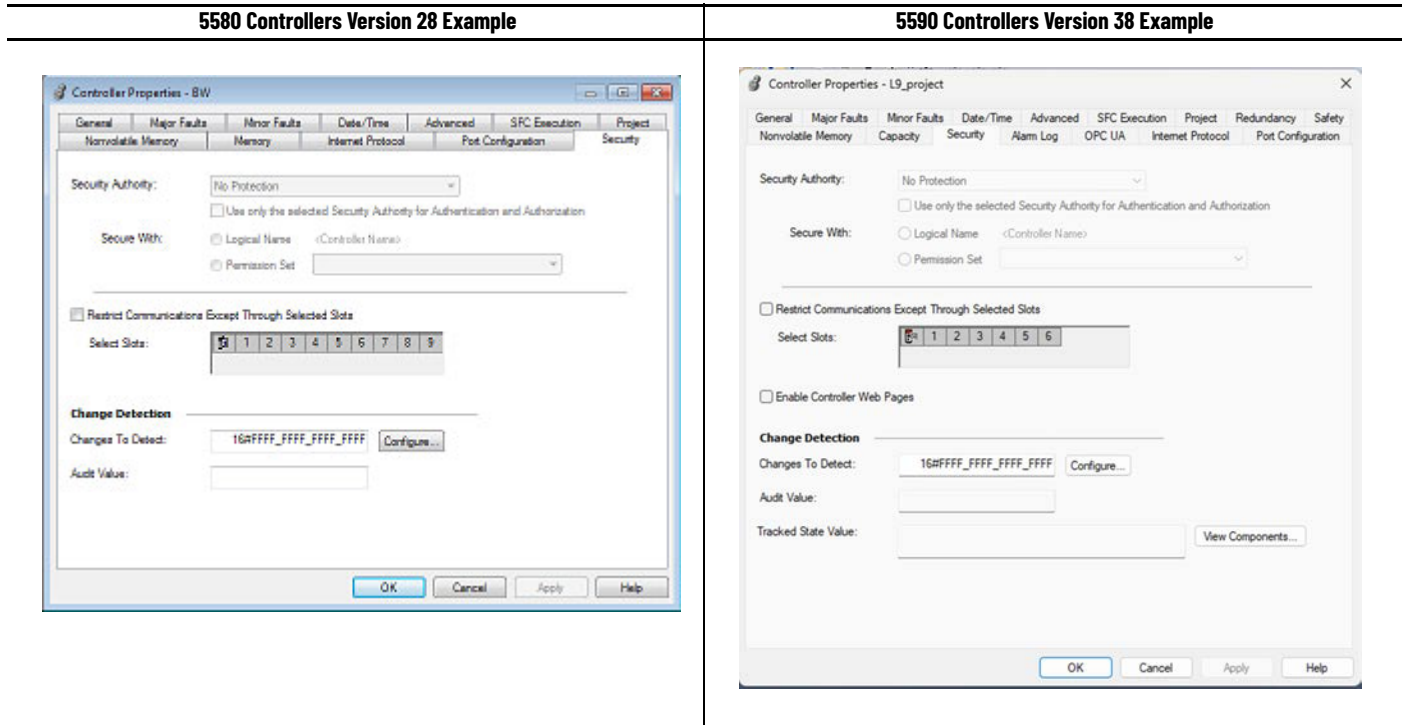

Memory Card Behavior

With 5590 controllers, memory card behavior has changed slightly when loading a project from the memory card onto a controller.

The table below shows what happens at power-up when you insert a memory card that contains an image into a 5590 controller in the different application types.

IMPORTANT

The difference with 5590 controllers, compared to previous ControlLogix and GuardLogix controllers, is when the controller is used in a SIL 3 safety application, the safety partner is installed, the Image Setting is User Initiated, and the controller is in out-of-box condition.

Table 6 - Memory Card Settings and Controller Power-up Behavior

Controller Application Type	Image Setting	Controller is in Out-of-Box Condition (v1.x firmware)	Firmware > 1.x and Internal Nonvolatile Memory is not Valid ⁽¹⁾	Firmware > 1.x and Internal Nonvolatile Memory is Valid ⁽¹⁾
<ul style="list-style-type: none"> Standard control High Availability (Redundancy and Logix SIS) SIL 2 safety 	User Initiated	Loads Firmware Only	Does Nothing	Does Nothing
		Loads both Firmware and Application ⁽²⁾		
SIL 3 safety with Safety Partner installed				
Any	On Power Up	Loads both Firmware and Application	<ul style="list-style-type: none"> Loads Firmware if there is a revision mismatch Loads Application 	<ul style="list-style-type: none"> Loads Firmware if there is a revision mismatch Loads Application
Any	On Uninitialized Memory	Loads both Firmware and Application	<ul style="list-style-type: none"> Loads Firmware if there is a revision mismatch Loads Application 	Does Nothing

(1) "Valid" includes the No Project condition.

(2) Indicates a change in behavior from previous ControlLogix and GuardLogix controllers.

Communication Options

Several communication networks are available for use. This table describes typical network applications that are used, and lists the networks available to support such applications.

Application Type	5580 Controllers - Supported Networks	5590 Controllers - Supported Networks
Communication options	<ul style="list-style-type: none"> • EtherNet/IP • ControlNet® • DeviceNet® • Data Highway Plus™ (DH+™) • Remote I/O • SynchLink™ • USB 	
Integrated Motion	<ul style="list-style-type: none"> • EtherNet/IP • SERCOS interface⁽¹⁾ • Analog options:⁽¹⁾ <ul style="list-style-type: none"> - Encoder input - LDT input - SSI input 	<ul style="list-style-type: none"> • EtherNet/IP • SERCOS interface • Analog options: <ul style="list-style-type: none"> - Encoder input - LDT input - SSI input
Time Synchronization	EtherNet/IP - Available with Integrated Motion and non-motion applications	
Control of distributed I/O	<ul style="list-style-type: none"> • EtherNet/IP - Primary network used • ControlNet • DeviceNet • Foundation Fieldbus • HART • Universal remote I/O 	
Produce/consume data between controllers	<ul style="list-style-type: none"> • ControlNet • EtherNet/IP 	
Messaging to and from other devices, including access to the controller via Logix Designer application	<ul style="list-style-type: none"> • ControlNet • DeviceNet (only to devices) • EtherNet/IP 	

(1) With Studio 5000 Logix Designer Application Version 31.00.00 or later.

Communication Throughput

5590 and 5580 controllers run communications the same except for moving data with CPS instructions and tag access as described below.

Tag Read/Write Source	CPS	
	5580 Controllers	5590 Controllers
Other User Tasks	Blocks	Allows
Motion Planner	Blocks	Allows

Blocks - Stops source data values from changing by communications during application execution.
 Allows - Communications can change source data values during application execution.

EtherNet/IP Modes

5590 controllers support the following EtherNet/IP modes:

- Dual-IP Mode
- Linear/DLR Mode

Dual-IP Mode

Dual-IP mode lets you configure the controller embedded Ethernet ports to connect to separate networks. That is, port 1 connect an enterprise-level Ethernet network and a port 2 can connect device-level network.

The following graphic shows a ControlLogix 5590 controller that uses Dual-IP mode in a star topology.

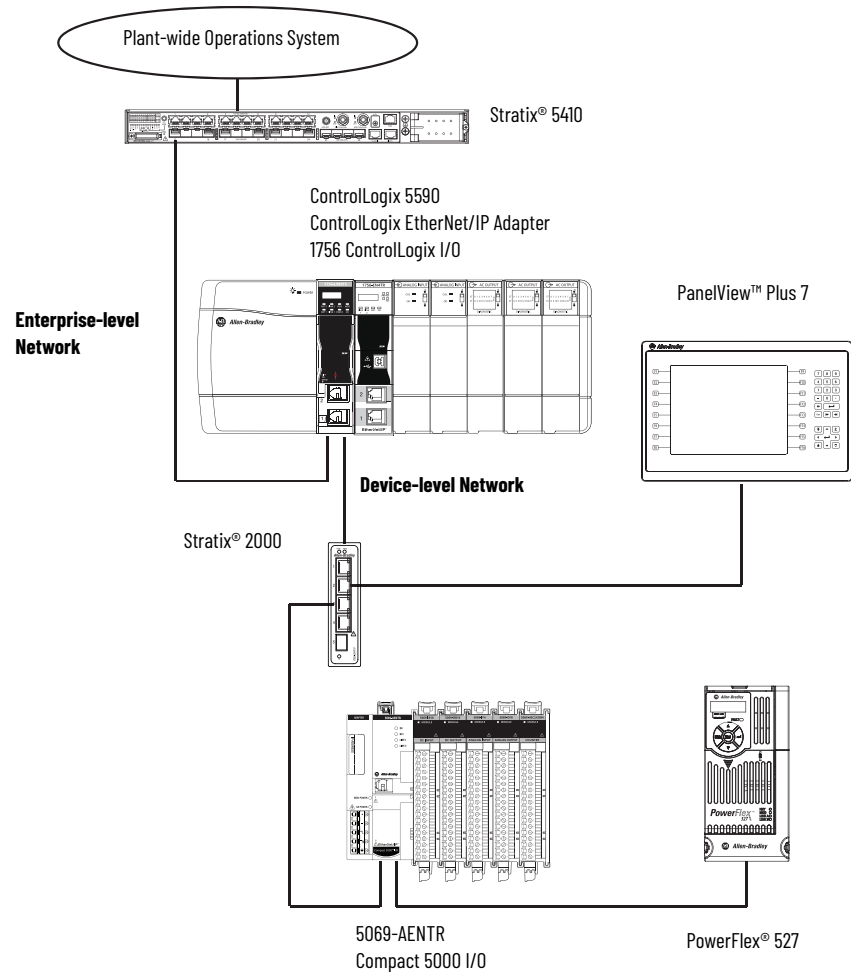

Linear/DLR Mode

When the controllers operate in Linear/DLR mode, they can only connect to one network and have only one network configuration. The controllers can connect to any EtherNet/IP topology.

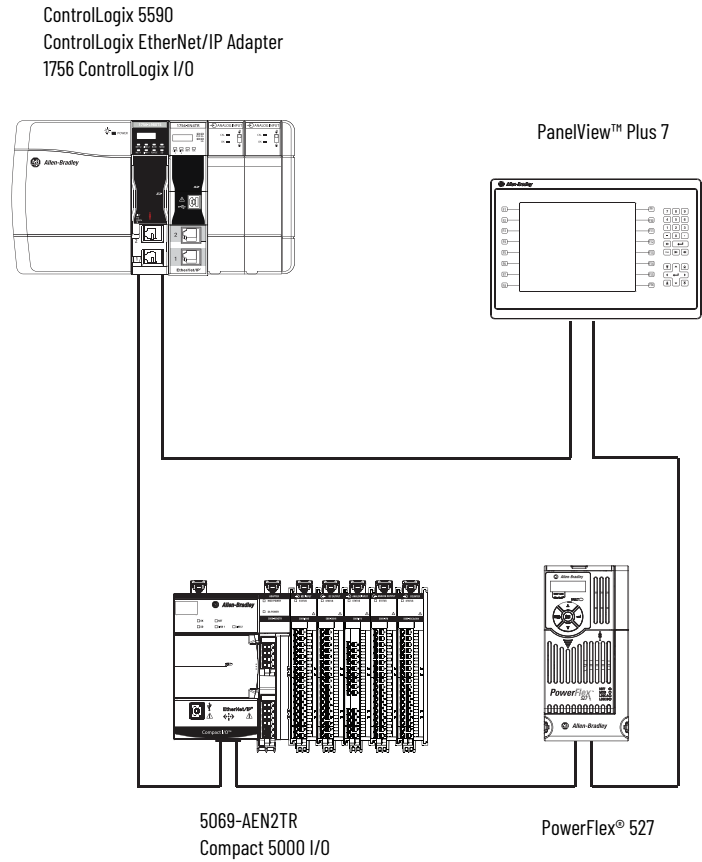

For more information on how to use EtherNet/IP modes, see the ControlLogix 5590 Controllers User Manual, publication [1756-UM900](#).

Thermal Monitoring and Thermal Fault Behavior

The controllers can monitor internal module temperatures and respond as the temperature increases.

Figure 20 - Controller Thermal Fault Behavior

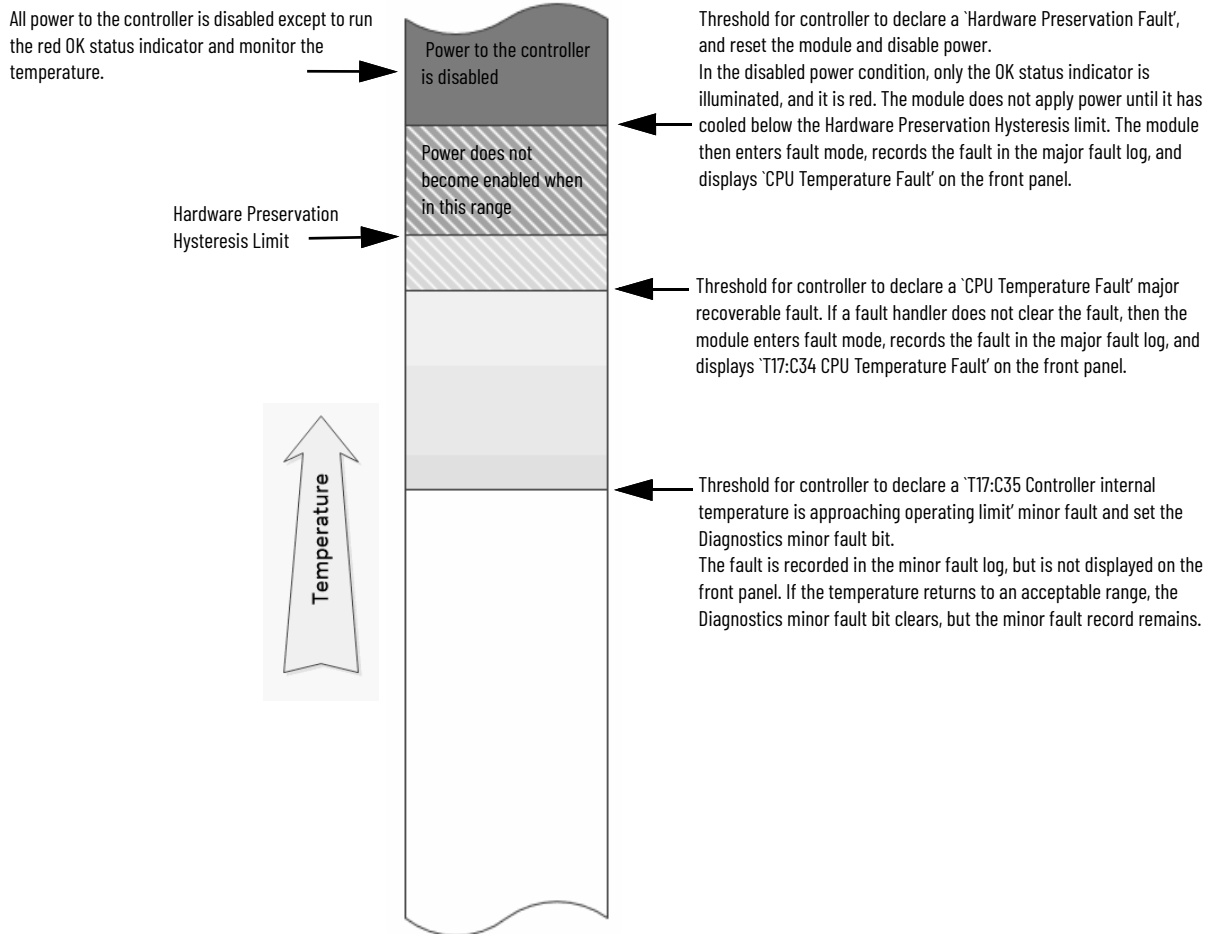

Notes:

Replacement Considerations with CompactLogix and Compact GuardLogix Systems

This chapter describes features and functions that are associated these controllers:

- CompactLogix™ 5380 controllers when used with the Studio 5000 Logix Designer® application, version 28 or later.
- Compact GuardLogix® 5380 SIL 2 controllers when used with the Studio 5000 Logix Designer application, version 31 or later.
- Compact GuardLogix® 5380 SIL 3 controllers when used with the Studio 5000 Logix Designer application, version 32 or later.

For information on replacing CompactLogix 1769-L3 or CompactLogix 1768-L4 controllers, see [Replacement Considerations for 1768-L4 and 1769-L3 Controllers on page 205](#).

This chapter features these controllers, and where applicable, the controllers are known as:

Controller Family	Includes These Controllers
5380 controllers	CompactLogix 5380, Compact GuardLogix 5380 SIL 2, and Compact GuardLogix 5380 SIL 3 controllers
5370 controllers	CompactLogix 5370 and Compact GuardLogix 5370 controllers

The features and functions that are described in this chapter are not an exhaustive list of the features and functions available with the controller. Instead, they provide a picture of what is new or changed in the controller at this release, including the following:

- Dual embedded 10/100/1000 Mbps Ethernet ports
- Dual-IP mode
- Higher performance and capacity including:
 - Total Motion processing: Support for up to 32 axes (limit differs by controller catalog number)
 - Total I/O packets processing: 128,000 pps
 - 320 unconnected message buffers
 - 256 simultaneous cached message instructions in the running state
 - Support for up to 180 Ethernet nodes (limit differs by controller catalog number)
- Support for Compact 5000® I/O modules as local and remote I/O modules
- Support for FLEX 5000® I/O modules as remote I/O modules
- Change Ethernet port speed without a module reset

Minimum Requirements

The controllers have these minimum requirements.

CompactLogix Controllers Minimum Requirements

Requirement, Minimum	CompactLogix 5370 L3 Controller	CompactLogix 5380 Controller
Programming Software	Studio 5000 Automation Engineering & Design Environment®, Version 20.00.00 or later	Studio 5000 Logix Designer Application, Version 28.00.00 or later ⁽¹⁾

(1) Most CompactLogix 5380 controllers are first available in version 29.00.00. Also, you must use version 29 or later to use Dual-IP mode with CompactLogix 5380 controllers.

Compact GuardLogix Controllers Minimum Requirements

Requirement, Minimum	Compact GuardLogix 5370 Controller	Compact GuardLogix 5380 Controller
Programming Software	Studio 5000 Automation Engineering & Design Environment, Version 28.00.00 or later	Compact GuardLogix 5380 SIL 2 Controller: Studio 5000 Logix Designer Application, Version 31.00.00 or later Compact GuardLogix 5380 SIL 3 Controller: Studio 5000 Logix Designer Application, Version 32.00.00 or later

Product Comparison

The 5380 controllers operate similar to the 5370 controllers, with these differences.

CompactLogix Controllers

Attribute	CompactLogix 5370 L3 Controller	CompactLogix 5380 Controller
Memory	1769-L30ER, 1769-L30ER-NSE, 1769-L30ERM: 1 MB 1769-L33ER, 1769-L33ERM: 2 MB 1769-L36ERM: 3 MB 1769-L37ERM: 4 MB 1769-L38ERM: 5 MB	5069-L306ER, 5069-L306ERM: 0.6 MB 5069-L310ER, 5069-L310ER-NSE, 5069-L310ERM: 1 MB 5069-L320ER, 5069-L320ERM, 5069-L320ERP: 2 MB 5069-L330ER, 5069-L330ERM: 3 MB 5069-L340ER, 5069-L340ERM, 5069-L340ERP: 4 MB 5069-L350ERM: 5 MB 5069-L380ERM: 8 MB 5069-L3100ERM: 10 MB
Local I/O modules supported	1769 Compact I/O™ only Number of local I/O modules that are supported varies by controller catalog number	Compact 5000 I/O standard modules only Number of local I/O modules that are supported varies by controller catalog number
Remote I/O modules supported	<ul style="list-style-type: none"> • 1794 FLEX™ I/O • 1769 Compact I/O™ • 1756 ControlLogix® I/O • 1734 POINT I/O™ • 1732E ArmorBlock® 	<ul style="list-style-type: none"> • 5094 FLEX 5000® I/O⁽¹⁾ • 5069 Compact 5000® I/O⁽²⁾ • 5034 PointMax™ I/O⁽³⁾ • 5032 ArmorBlock 5000® I/O⁽⁴⁾ • 1794 FLEX I/O • 1769 Compact I/O • 1756 ControlLogix I/O • 1734 POINT I/O • 1732E ArmorBlock
Embedded Ethernet	10/100 Mbps	10/100/1000 Mbps
EtherNet/IP™ nodes supported, max	1769-L30ER, 1769-L30ER-NSE, 1769-L30ERM: 16 1769-L33ER, 1769-L33ERM: 32 1769-L36ERM: 48 1769-L37ERM: 64 1769-L38ERM: 80	5069-L306ER, 5069-L306ERM: 16 5069-L310ER, 5069-L310ER-NSE, 5069-L310ERM: 24 5069-L320ER, 5069-L320ERM, 5069-L320ERP: 40 5069-L330ER, 5069-L330ERM: 60 5069-L340ER, 5069-L340ERM, 5069-L340ERP: 90 5069-L350ERM: 120 5069-L380ERM: 150 5069-L3100ERM: 180
Ethernet performance	I/O Capacity (Class 0/1): 10,000 packets per second max Message Rate Capacity HMI/MSG (Class 3): 400 packets per second max	I/O Capacity (Class 0/1) ⁽⁵⁾ : 128,000 packets per second Message Rate Capacity HMI/MSG (Class 3) ⁽⁵⁾ : 2000 messages per second ⁽⁶⁾
Dual-IP mode	Not supported	Supported with the Logix Designer application, version 29 or later
Unconnected message buffers	No fixed limits, as long as the controller can allocate the buffer it will.	320 - Any combination of outgoing or incoming unconnected messages.
Concurrent cached message instructions in the running state	32, drawn from the 250 total connections supported by the controller.	256 dedicated buffers
HMI and Messaging (Class 3)	Drawn from the 250 total connections supported by the controller.	512 dedicated messages (256 incoming messages and 256 outgoing messages)
Integrated motion	EtherNet/IP™ network	

Attribute	CompactLogix 5370 L3 Controller	CompactLogix 5380 Controller
Motion axes ⁽⁷⁾	<p>Position Loop:</p> <ul style="list-style-type: none"> 1769-L30ERM - As many as 4 axes 1769-L33ERM- As many as 8 axes 1769-L36ERM, 1769-L37ERM, 1769-L38ERM - As many as 16 axes <p>Other Loop Types:</p> <ul style="list-style-type: none"> Up to 100 <p>Integrated Motion Drives:</p> <ul style="list-style-type: none"> Up to 80 max nodes, depending on controller catalog number 	<p>Position Loop:</p> <ul style="list-style-type: none"> 5069-L306ERM: As many as 2 axes 5069-L310ERM: As many as 4 axes 5069-L320ERM, 5069-L320ERP: As many as 8 axes 5069-L330ERM: As many as 16 axes 5069-L340ERM, 5069-L340ERP: As many as 20 axes 5069-L350ERM: As many as 24 axes 5069-L380ERM: As many as 28 axes 5069-L3100ERM: As many as 32 axes <p>Other Loop Types:</p> <ul style="list-style-type: none"> Up to 256 <p>Integrated Motion Drives:</p> <ul style="list-style-type: none"> Up to 180 max nodes, depending on controller catalog number and firmware revision
Axes/ms over EtherNet/IP™ port	<p>As many as 2 (2 ms coarse update period and 50% controller load)</p> <p>IMPORTANT: Not all CompactLogix 5370 controllers support Integrated Motion over an EtherNet/IP network.</p>	<p>As many as 32 when you use the built-in EtherNet/IP port at 1 Gbps</p> <p>IMPORTANT: Not all CompactLogix 5380 controllers support Integrated Motion over an EtherNet/IP network.</p>
Voltage and current ratings	<p>Controller power: 500 mA @ 5.1V DC and 225 mA @ 24V DC</p>	<p>MOD Power: 450 mA @ 18...32V DC MOD Power Inrush: 850 mA for 125 ms SA Power: 10 mA @ 0...32V DC 25 mA @ 0...240V AC, 47...63 Hz ATEX/IECEX, 125V AC Max MOD Power (Passthrough)⁽⁸⁾: 9.55 A @ 18...32V DC SA Power (Passthrough)⁽⁹⁾: 9.95 A @ 0...32V DC 9.975 A @ 0...240V AC, 47...63 Hz ATEX/IECEX, 125V AC Max</p>
Energy storage module	Nonremovable	Nonremovable
Weight, approx	0.31 kg (0.68 lb)	0.394 kg (.868 lb)
Wire category ⁽¹⁰⁾	<p>3 - on USB port</p> <p>2 - on Ethernet port</p>	<p>3 - on USB port</p> <p>1 - on power ports</p> <p>2 - on Ethernet port</p>
Wire size	<p>RJ45 connector according to IEC 60603-7, 2 or 4 pair Category 5e minimum cable according to TIA 568-B.1 or Category 5 cable according to ISO/IEC 24702</p>	<p>Ethernet connections: Ethernet Cabling and Installation according to IEC 61918 and IEC 61784-5-2</p>
Removable terminal block	Not Applicable	<p>Kit 5069-RTB64-SCREW or kit 5069-RTB64-SPRING You must order the kit separately. RTBs do not ship with the controller. 5069-RTB4-SCREW, 5069-RTB6-SCREW connections: 0.5...1.5 mm² (22...16 AWG) solid or stranded copper wire rated at 105 °C (221 °F), or greater, 3.5 mm (0.14 in.) max diameter including insulation, single wire connection only 5069-RTB4-SPRING, 5069-RTB6-SPRING connections: 0.5...1.5 mm² (22...16 AWG) solid or stranded copper wire rated at 105 °C (221 °F), or greater, 2.9 mm (0.11 in.) max diameter including insulation, single wire connection only</p>
Reset Button	<p>Clears the user application and memory but retains the firmware revision and all network settings</p>	<p>A stage 1 reset clears the user application program and memory, but retains the controller IP address. A stage 2 reset returns the controller to out-of-box settings (including firmware), and clears all network settings.</p>

(1) With Studio 5000 Logix Designer application, version 32.00.00 or later.
 (2) With Studio 5000 Logix Designer application, version 31.00.00 or later.
 (3) With Studio 5000 Logix Designer, application, version 36 or later, applications.
 (4) With Studio 5000 Logix Designer, application, version 35 or later, applications.
 (5) I/O numbers are maximums; they assume no HMI/MSG. HMI/MSG numbers are maximums, they assume no I/O. HMI/MSG maximums assume that the processor is target, not originator. Packet rates vary depending on packet size. For more details, see Troubleshoot EtherNet/IP Application Technique, publication [ENET-AT003](#), and the EDS file for a specific catalog number.
 (6) Data size = 32-bits / 1-DINT
 (7) For information on motion axes and Integrated Motion on an EtherNet/IP network, see the Integrated Motion on the EtherNet/IP Network: Configuration and Startup User Manual, publication [MOTION-UM003](#).
 (8) Maximum level of MOD Power current that the module can pass through to the next module in the system. The specific level of current passed through varies based on system configuration.
 (9) Maximum level of SA Power current that the module can pass through to the next module in the system. The specific level of current passed through varies based on system configuration.
 (10) Use this conductor category information for planning conductor routing. See the Industrial Automation Wiring and Grounding Guidelines, publication [1770-4.1](#).

Compact GuardLogix Controllers

Attribute	Compact GuardLogix 5370 Controller	Compact GuardLogix 5380 Controller
Controller Memory	1769-L30ERMS: 1 MB standard, 0.5 MB safety 1769-L33ERMS: 2 MB standard, 1 MB safety 1769-L36ERMS: 3 MB standard, 1.5 MB safety 1769-L37ERMS: 4 MB + 1.5 MB safety 1769-L38ERMS: 5 MB + 1.5 MB safety	5069-L306ERS2, 5069-L306ERMS2, 5069-L3100ERMS3: 0.6 MB + 0.3 MB Safety 5069-L310ERS2, 5069-L310ERMS2, 5069-L310ERMS3: 1 MB + 0.5 MB Safety 5069-L320ERS2, 5069-L320ERMS2, 5069-L320ERMS3: 2 MB + 1 MB Safety 5069-L330ERS2, 5069-L330ERMS2, 5069-L330ERMS3: 3 MB + 1.5 MB Safety 5069-L340ERS2, 5069-L340ERMS2, 5069-L340ERMS3: 4 MB + 2 MB Safety 5069-L350ERS2, 5069-L350ERMS2, 5069-L350ERMS3: 5 MB + 2.5 MB Safety 5069-L380ERS2, 5069-L380ERMS2, 5069-L380ERMS3: 8 MB + 4 MB Safety 5069-L3100ERS2, 5069-L3100ERMS2, 5069-L3100ERMS3: 10 MB + 5 MB Safety
Local I/O modules supported	<ul style="list-style-type: none"> 1769 Compact I/O only Number of local I/O modules that are supported varies by controller catalog number 	<ul style="list-style-type: none"> Compact 5000 I/O Standard and Safety modules only Number of local I/O modules that are supported varies by controller catalog number
Remote I/O modules supported	<ul style="list-style-type: none"> 1794 FLEX I/O 1769 Compact I/O 1756 ControlLogix I/O 1734 POINT I/O 1732E ArmorBlock 	<ul style="list-style-type: none"> 5094 FLEX 5000 I/O⁽¹⁾ 5069 Compact 5000 I/O⁽²⁾ 5034 PointMax I/O⁽³⁾ 5032 ArmorBlock 5000 I/O⁽⁴⁾ 1794 FLEX I/O 1769 Compact I/O 1756 ControlLogix I/O 1734 POINT I/O 1732E ArmorBlock
Safety I/O support	<ul style="list-style-type: none"> 1734 POINT Guard I/O™, 1732 ArmorBlock® Guard I/O, 1791 CompactBlock™ Guard I/O™ Can only communicate to safety I/O through the embedded Ethernet ports. 	<ul style="list-style-type: none"> Compact 5000 I/O Safety modules, 1734 POINT Guard I/O, 1732 ArmorBlock Guard I/O, 1791 CompactBlock Guard I/O, 1756 ControlLogix Digital Safety I/O Can communicate to local Compact 5000 I/O safety modules through the backplane, and also communicate to distributed safety I/O through the embedded Ethernet ports. Can communicate to DeviceNet® safety I/O nodes with the 1788-EN2DNR Ethernet to DeviceNet linking device.
Embedded Ethernet	10/100 Mbps	10/100/1000 Mbps
EtherNet/IP nodes supported, max	1769-L30ERMS: 16 1769-L33ERMS: 32 1769-L36ERMS: 48 1769-L37ERMS: 64 1769-L38ERMS: 80	5069-L306ERS2, 5069-L306ERMS2, 5069-L306ERMS3: 16 5069-L310ERS2, 5069-L310ERMS2, 5069-L310ERMS3: 24 5069-L320ERS2, 5069-L320ERMS2, 5069-L320ERMS3: 40 5069-L330ERS2, 5069-L330ERMS2, 5069-L330ERMS3: 60 5069-L340ERS2, 5069-L340ERMS2, 5069-L340ERMS3: 90 5069-L350ERS2, 5069-L350ERMS2, 5069-L350ERMS3: 120 5069-L380ERS2, 5069-L380ERMS2, 5069-L380ERMS3: 150 5069-L3100ERS2, 5069-L3100ERMS2, 5069-L3100ERMS3: 180
Ethernet performance	Ethernet I/O (Class 0/1): 10,000 packets per second max Ethernet Messaging (Class 3): 400 packets per second max	Ethernet I/O (Class 0/1): 128,000 packets per second Ethernet Messaging (Class 3): 2000 messages per second ⁽⁵⁾
Dual-IP mode	Not supported	<ul style="list-style-type: none"> Compact GuardLogix 5380 SIL 2 controllers are supported with the Logix Designer application, version 31 or later Compact GuardLogix 5380 SIL 3 controllers are supported with the Logix Designer application, version 32 or later
Unconnected message buffers	No fixed limits, as long as the controller can allocate the buffer it will.	320 - Any combination of outgoing or incoming unconnected messages.
Concurrent cached message instructions in the running state	32, drawn from the 250 total connections supported by the controller.	256 dedicated buffers
HMI and Messaging (Class 3)	Drawn from the 250 total connections supported by the controller.	512 dedicated messages (256 incoming messages and 256 outgoing messages)
Integrated motion	EtherNet/IP network	

Attribute	Compact GuardLogix 5370 Controller	Compact GuardLogix 5380 Controller
Motion axes ⁽⁶⁾	Position Loop: <ul style="list-style-type: none"> • 1769-L30ERMS - As many as 4 axes • 1769-L33ERMS - As many as 8 axes • 1769-L36ERMS, 1769-L37ERMS, 1769-L38ERMS - As many as 16 axes Other Loop Types: <ul style="list-style-type: none"> • Up to 100 Integrated Motion Drives: <ul style="list-style-type: none"> • Up to 80 max nodes, depending on controller catalog number 	Position Loop: <ul style="list-style-type: none"> 5069-L306ERMS2, 5069-L306ERMS3: As many as 2 axes 5069-L310ERMS2, 5069-L310ERMS3: As many as 4 axes 5069-L320ERMS2, 5069-L320ERMS3: As many as 8 axes 5069-L330ERMS2, 5069-L330ERMS3: As many as 16 axes 5069-L340ERMS2, 5069-L340ERMS3: As many as 20 axes 5069-L350ERMS2, 5069-L350ERMS3: As many as 24 axes 5069-L380ERMS2, 5069-L380ERMS3: As many as 28 axes 5069-L3100ERMS2, 5069-L3100ERMS3: As many as 32 axes Other Loop Types: <ul style="list-style-type: none"> • Up to 256 Integrated Motion Drives: <ul style="list-style-type: none"> • Up to 180 max nodes, depends on controller catalog number and firmware revision
Axes/ms over EtherNet/IP port	As many as 2 (2 ms coarse update period and 50% controller load)	As many as 32 when you use the built-in EtherNet/IP port at 1 Gbps IMPORTANT: Not all Compact GuardLogix 5380 controllers support Integrated Motion over an EtherNet/IP network.
Voltage and current ratings	Controller power: 850 mA @ 5.1V DC and 700 mA @ 24V DC	Compact GuardLogix 5380 SIL 2 controllers: <ul style="list-style-type: none"> • MOD Power: 475 mA @ 18...32V DC • MOD Power Inrush: 1200 mA for 125 ms • SA Power: 10 mA @ 0...32V DC • MOD Power (Passthrough)⁽⁷⁾: 4.525 A @ 18...32V DC • SA Power (Passthrough)⁽⁸⁾: 9.99 A @ 0...32V DC Compact GuardLogix 5380 SIL 3 controllers: <ul style="list-style-type: none"> • MOD Power: 950 mA @ 18...32V DC • MOD Power Inrush: 2.375 A • SA Power: 10 mA @ 0...32V DC • MOD Power (Passthrough)⁽⁷⁾: 4.05 A @ 18...32V DC • SA Power (Passthrough)⁽⁸⁾: 9.99 A @ 0...32V DC
Energy storage module	Nonremovable	Nonremovable
Weight, approx	0.54 kg (1.18 lb)	Compact GuardLogix 5380 SIL 2 controllers: 0.768 kg (1.693 lb) Compact GuardLogix 5380 SIL 3 controllers: 1.2 kg (2.645 lb)
Wire category ⁽⁹⁾	3 - on USB port 2 - on Ethernet port	3 - on USB port 1 - on power ports 2 - on Ethernet port
Wire size	RJ45 connector according to IEC 60603-7, 2 or 4 pair Category 5e minimum cable according to TIA 568-B.1 or Category 5 cable according to ISO/IEC 24702	Ethernet connections: Ethernet Cabling and Installation according to IEC 61918 and IEC 61784-5-2
Removable terminal block	Not applicable	Kit 5069-RTB64-SCREW or kit 5069-RTB64-SPRING You must order the kit separately. RTBs do not ship with the controller. 5069-RTB4-SCREW, 5069-RTB6-SCREW connections: 0.5...1.5 mm ² (22...16 AWG) solid or stranded copper wire rated at 105 °C (221 °F), or greater, 3.5 mm (0.14 in.) max diameter including insulation, single wire connection only 5069-RTB4-SPRING, 5069-RTB6-SPRING connections: 0.5...1.5 mm ² (22...16 AWG) solid or stranded copper wire rated at 105 °C (221 °F), or greater, 2.9 mm (0.11 in.) max diameter including insulation, single wire connection only
Reset Button	Clears the user application and memory but retains the firmware revision and all network settings	A stage 1 reset clears the user application program and memory, but retains the controller IP address. A stage 2 reset returns the controller to out-of-box settings (including firmware), and clears all network settings.

(1) With Studio 5000 Logix Designer application, version 32.00.00 or later.
 (2) With Studio 5000 Logix Designer application, version 31.00.00 or later.
 (3) With Studio 5000 Logix Designer, application, version 36 or later, applications.
 (4) With Studio 5000 Logix Designer, application, version 35 or later, applications.
 (5) Data size = 32-bits / 1-DINT
 (6) For information on motion axes and Integrated Motion on an EtherNet/IP network, see the Integrated Motion on the EtherNet/IP Network: Configuration and Startup User Manual, publication [MOTION-UM003](#).
 (7) Maximum level of MOD Power current that the module can pass through to the next module in the system. The specific level of current passed through varies based on system configuration.
 (8) Maximum level of SA Power current that the module can pass through to the next module in the system. The specific level of current passed through varies based on system configuration.
 (9) Use this conductor category information for planning conductor routing. See the Industrial Automation Wiring and Grounding Guidelines, publication [1770-4.1](#).

Controller Spacing

Controller spacing differs between the 5370 controllers and the 5380 controllers. The graphics in this section are not to scale.

CompactLogix 5370 L3 and Compact GuardLogix 5370 L3 Spacing

Maintain spacing from enclosure walls, wireways, and adjacent equipment.

Leave 50.80 mm (2.00 in.) of space on all sides, as shown. This spacing provides ventilation and electrical isolation.

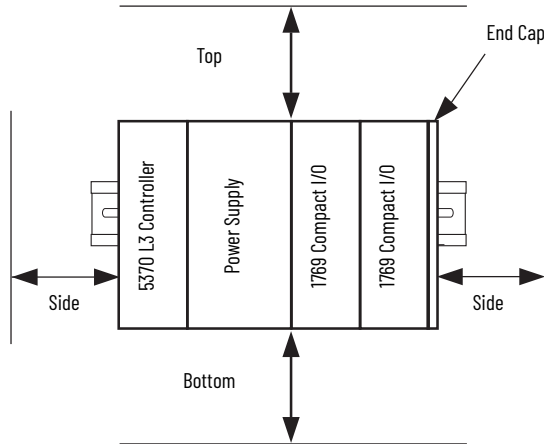

CompactLogix 5380 Spacing

Maintain spacing from enclosure walls, wireways, and adjacent equipment.

The minimum distance on all sides of the CompactLogix 5380 system varies based on the operating temperature, as follows:

- 50.80 mm (2.00 in.) at 55 °C (131 °F)
- 101.60 mm (4.00 in.) at 60 °C (140 °F)

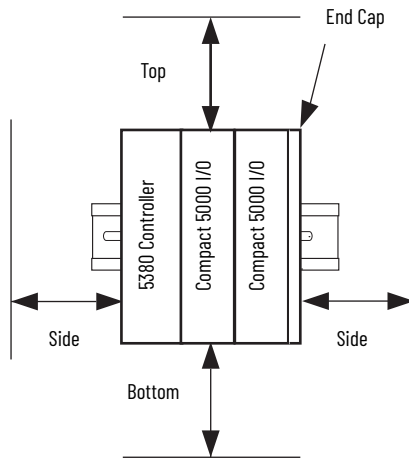

Compact GuardLogix 5380 Spacing

Maintain spacing from enclosure walls, wireways, and adjacent equipment. The minimum distance on all sides of the Compact GuardLogix 5380 system varies based on the operating temperature, as follows:

Compact GuardLogix SIL 2 Controllers	Series A catalog numbers: <ul style="list-style-type: none"> • 50.80 mm (2.00 in.) at 50 °C (131 °F) • 101.60 mm (4.00 in.) at 55 °C (122 °F) • 152.40 mm (6.00 in.) at 60 °C (140 °F) Series B catalog numbers: <ul style="list-style-type: none"> • 50.8 mm (2.00 in.) at 55 °C (131 °F) • 101.6 mm (4.00 in.) at 60 °C (140 °F)
Compact GuardLogix SIL 3 Controllers	<ul style="list-style-type: none"> • 50.8 mm (2.00 in.) at 55 °C (131 °F) • 101.6 mm (4.00 in.) at 60 °C (140 °F)

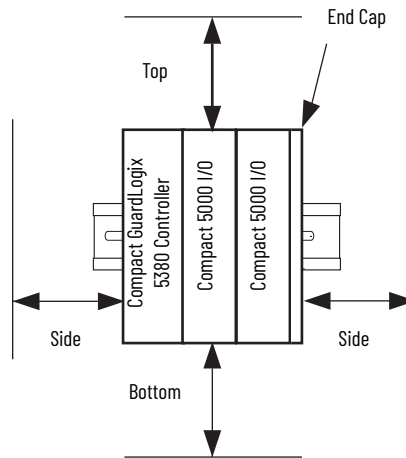

Controller Dimensions

This section shows dimensional differences.

CompactLogix 5370 L3 Dimensions

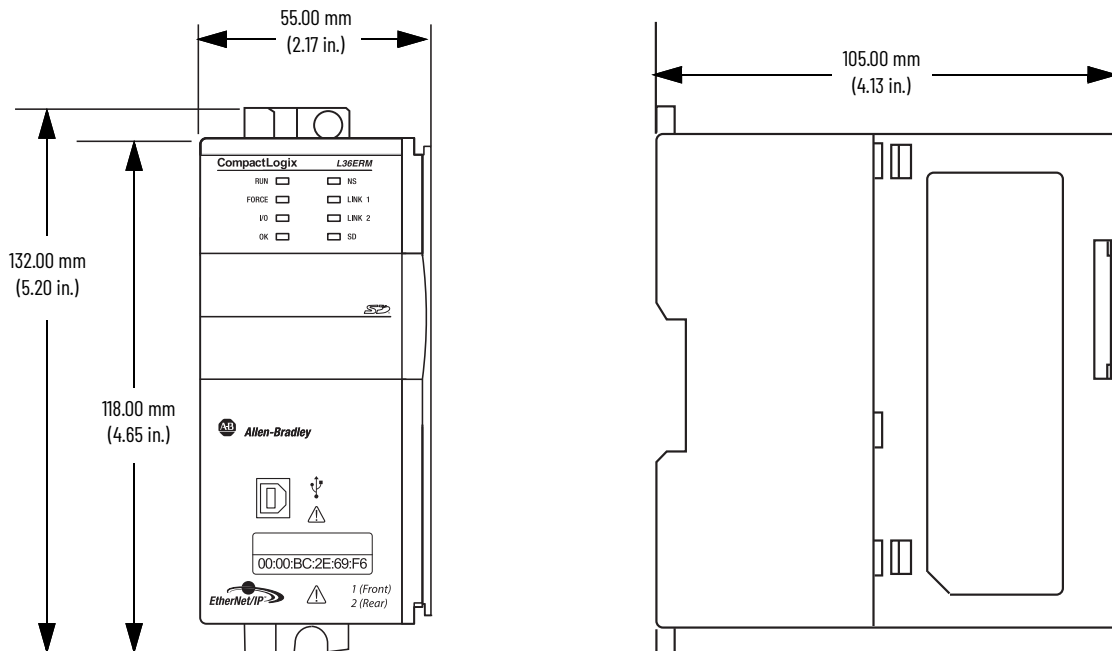

CompactLogix 5380 Dimensions

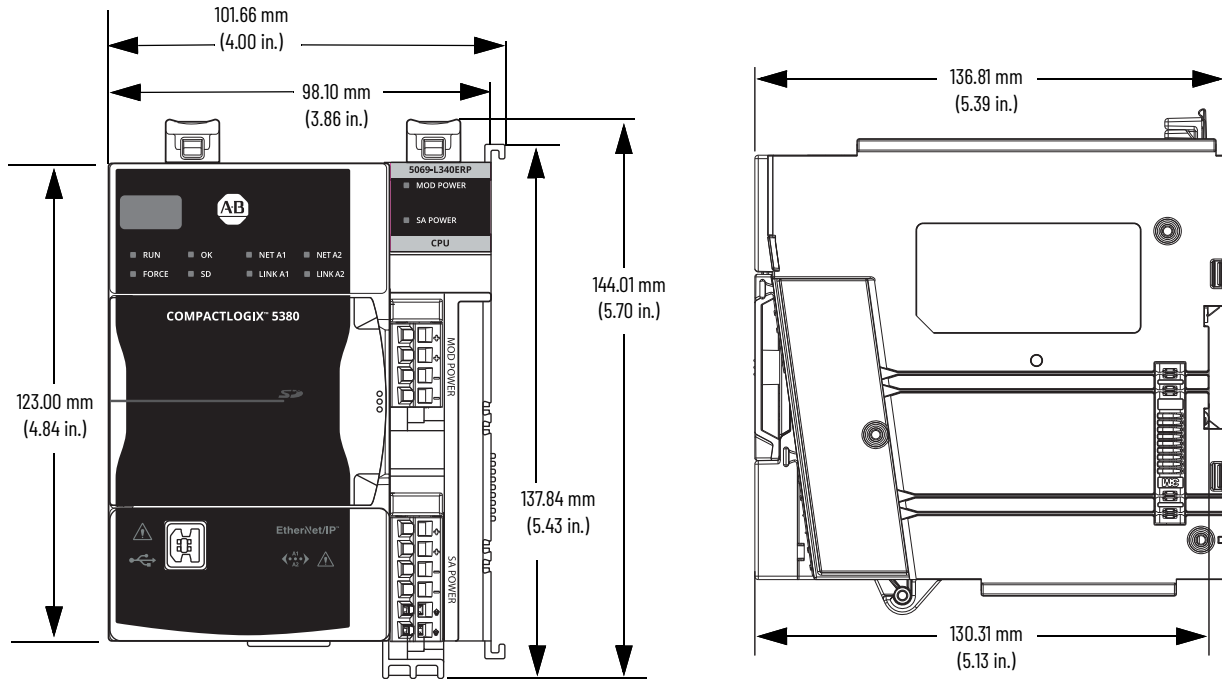

Compact GuardLogix 5370 Dimensions

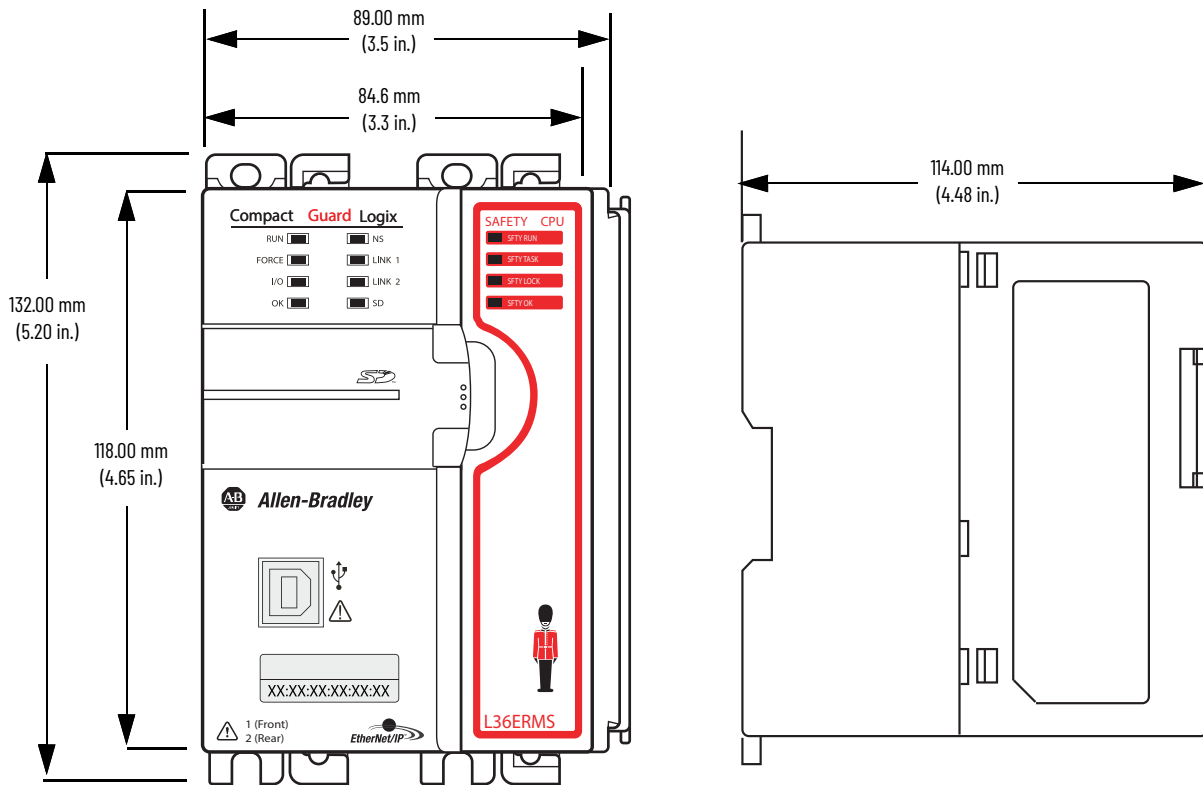

Compact GuardLogix 5380 SIL 2 Controller Dimensions

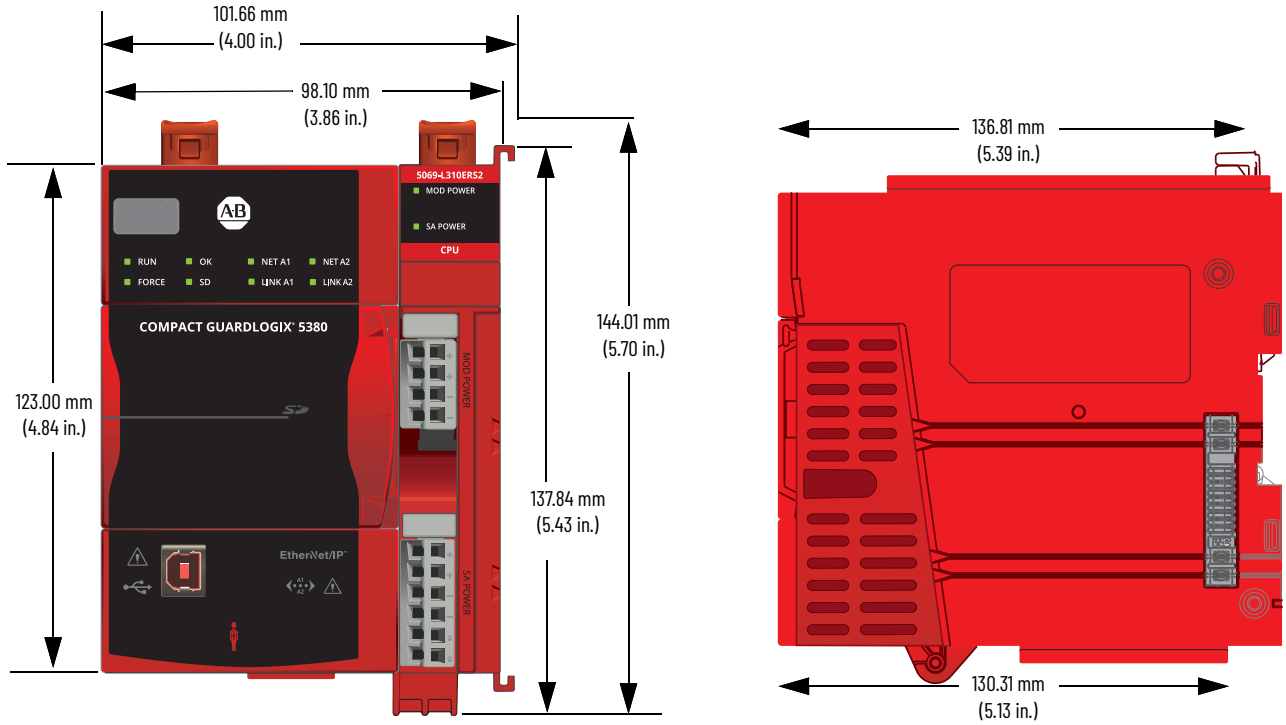

Compact GuardLogix 5380 SIL 3 Controller Dimensions

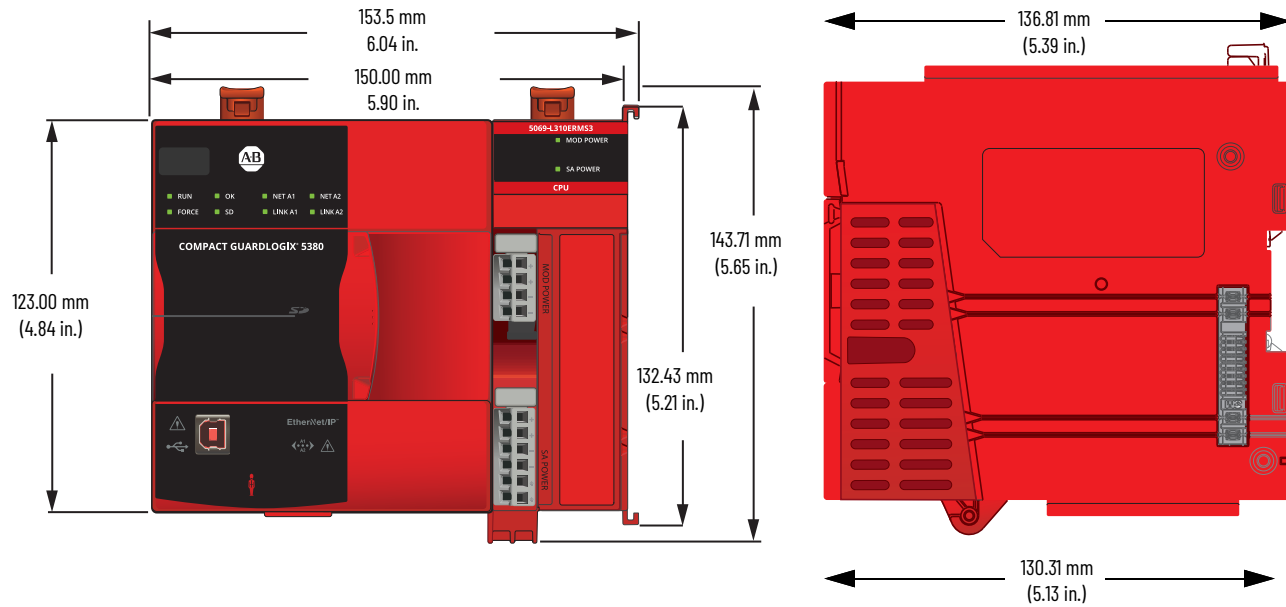

Connectors and Status Indicators

The following tables show the differences between the connectors and status indicators.

For more information on the controller status indicators and reset button, see Chapter 10, [Diagnostics and Status Indicators with CompactLogix Systems on page 193](#).

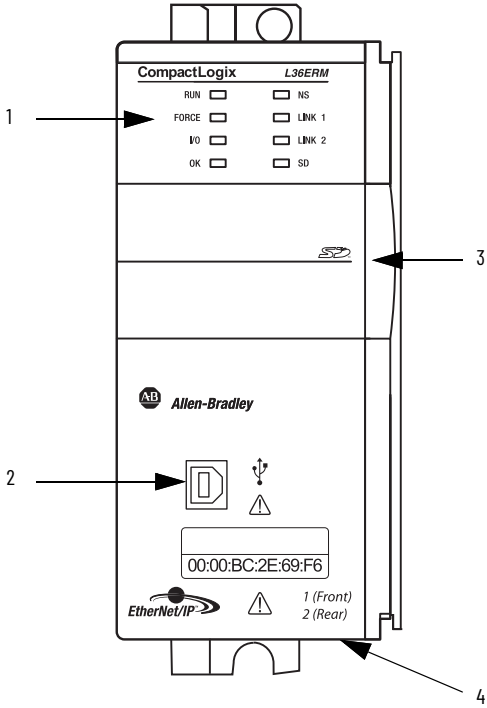
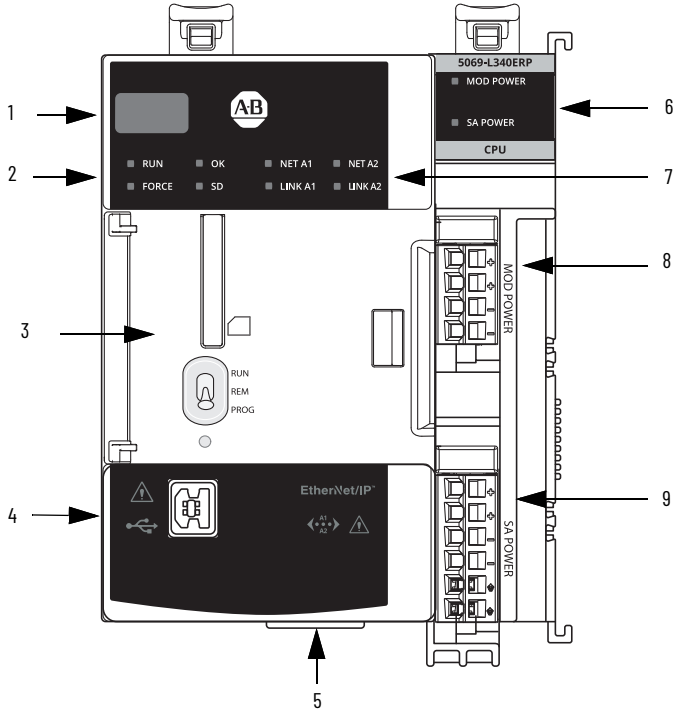
CompactLogix 5370 L3	CompactLogix 5380																														
 <p>The diagram shows the front panel of the CompactLogix 5370 L3 controller. It features a 4-character display at the top, followed by a row of status indicators (RUN, FORCE, I/O, OK, NS, LINK 1, LINK 2, SD). Below these is a USB port and an SD card slot. At the bottom, there are Ethernet ports 1 and 2. A door is shown partially open, revealing a mode switch and a reset button.</p>	 <p>The diagram shows the front panel of the CompactLogix 5380 controller. It features a 4-character display at the top, followed by a row of status indicators (RUN, FORCE, OK, SD, NET A1, LINK A1, NET A2, LINK A2). Below these is a mode switch and a reset button. To the right, there are power connections for MOD POWER and SA POWER. At the bottom, there are Ethernet ports 1 and 2.</p>																														
<table border="1" style="width: 100%; border-collapse: collapse;"> <thead> <tr> <th style="width: 10%;">Item</th> <th style="width: 90%;">Description</th> </tr> </thead> <tbody> <tr> <td>1</td> <td>Status Indicators</td> </tr> <tr> <td>2</td> <td>USB port</td> </tr> <tr> <td>3</td> <td>Behind the door: <ul style="list-style-type: none"> • RUN REM PROG mode switch • Reset button • SD card slot </td> </tr> <tr> <td>4</td> <td>Ethernet ports 1 and 2</td> </tr> </tbody> </table>	Item	Description	1	Status Indicators	2	USB port	3	Behind the door: <ul style="list-style-type: none"> • RUN REM PROG mode switch • Reset button • SD card slot 	4	Ethernet ports 1 and 2	<table border="1" style="width: 100%; border-collapse: collapse;"> <thead> <tr> <th style="width: 10%;">Item</th> <th style="width: 90%;">Description</th> </tr> </thead> <tbody> <tr> <td>1</td> <td>4-character display</td> </tr> <tr> <td>2</td> <td>Controller Status Indicators</td> </tr> <tr> <td>3</td> <td>Behind the door: <ul style="list-style-type: none"> • RUN REM PROG mode switch • Reset button • SD card slot </td> </tr> <tr> <td>4</td> <td>USB port</td> </tr> <tr> <td>5</td> <td>Ethernet ports 1 and 2</td> </tr> <tr> <td>6</td> <td>Power Status Indicators</td> </tr> <tr> <td>7</td> <td>EtherNet/IP Status Indicators</td> </tr> <tr> <td>8</td> <td>MOD power connection</td> </tr> <tr> <td>9</td> <td>SA power connection</td> </tr> </tbody> </table>	Item	Description	1	4-character display	2	Controller Status Indicators	3	Behind the door: <ul style="list-style-type: none"> • RUN REM PROG mode switch • Reset button • SD card slot 	4	USB port	5	Ethernet ports 1 and 2	6	Power Status Indicators	7	EtherNet/IP Status Indicators	8	MOD power connection	9	SA power connection
Item	Description																														
1	Status Indicators																														
2	USB port																														
3	Behind the door: <ul style="list-style-type: none"> • RUN REM PROG mode switch • Reset button • SD card slot 																														
4	Ethernet ports 1 and 2																														
Item	Description																														
1	4-character display																														
2	Controller Status Indicators																														
3	Behind the door: <ul style="list-style-type: none"> • RUN REM PROG mode switch • Reset button • SD card slot 																														
4	USB port																														
5	Ethernet ports 1 and 2																														
6	Power Status Indicators																														
7	EtherNet/IP Status Indicators																														
8	MOD power connection																														
9	SA power connection																														

Compact GuardLogix 5370

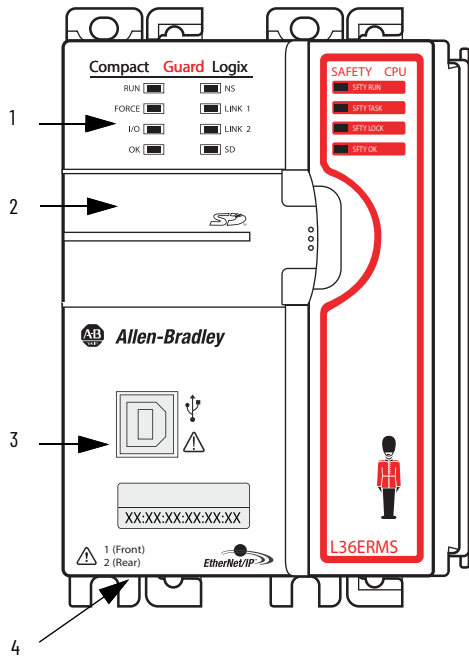

Item	Description
1	Status Indicators
2	Behind the door: • RUN REM PROG mode switch • Reset button • SD card slot
3	USB port
4	Ethernet ports 1 and 2

Compact GuardLogix 5380 SIL 2

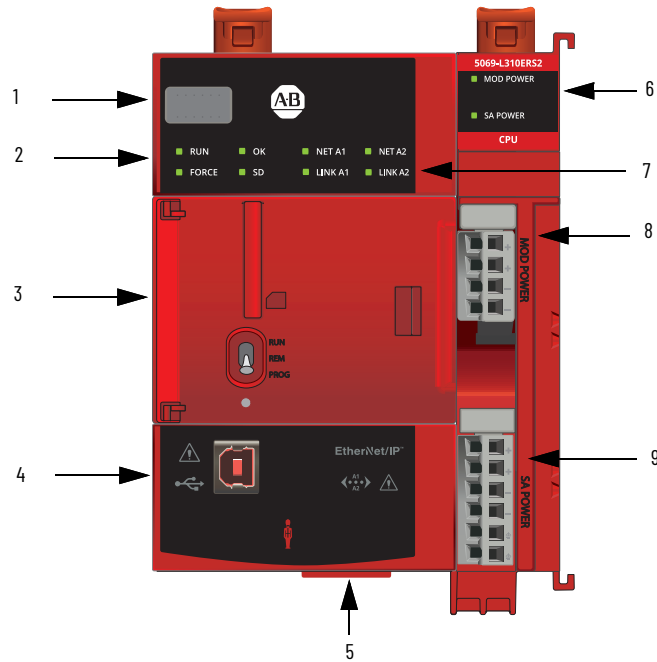

Item	Description
1	4-character display
2	Controller Status Indicators
3	Behind the door: • RUN REM PROG mode switch • Reset button • SD card slot
4	USB port
5	Ethernet ports 1 and 2
6	Power Status Indicators
7	EtherNet/IP Status Indicators
8	MOD power connection
9	SA power connection

Compact GuardLogix 5380 SIL 3

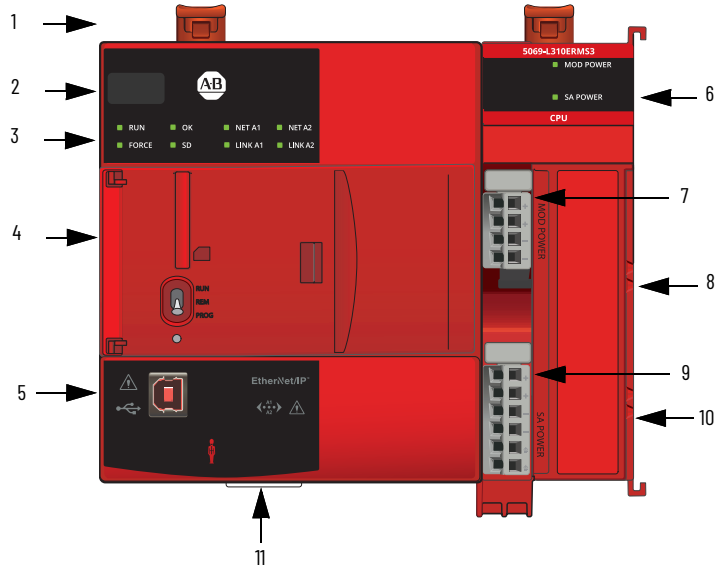

1	DIN Rail Latches
2	Four-character Display
3	Status Indicators
4	Behind the door: <ul style="list-style-type: none"> • RUN REM PROG mode switch • Reset button • SD card slot
5	USB Port
6	Module Power and Sensor Actuator Power Status Indicators
7	MOD Power RTB
8	MOD Power Bus Connector
9	SA Power RTB
10	SA Power Bus Connector
11	Ethernet ports (bottom of controller)

Power the Controller

There are differences in how to power the 5380 controllers versus the 5370 controllers. [Table 7](#) highlights some of the power differences.

For information on how to power your system, see the CompactLogix 5380 and Compact GuardLogix 5380 Controllers User Manual, publication [5069-UM001](#).

Table 7 - Power Differences

	CompactLogix 5370 L3 System, Compact GuardLogix 5370 L3 System	CompactLogix 5380 System	Compact GuardLogix 5380 System
Power source	Compact I/O power supply	External power supply	
Power source location	Power supply that is installed in the system The power supply location is based on the requirements of the modules in the system.	Separate from the system and connected to RTBs on controller The modules that are installed in the system do not impact the power supply location. Power is transferred to the system via removable terminal blocks (RTBs) on the controller.	
Power types provided	System-side power only	<ul style="list-style-type: none"> System-side power via MOD Power RTB Field-side power via SA Power RTB IMPORTANT: RTBs do not ship with the controller. The RTBs are available in kits that you must order separately. Kit 5069-RTB64-SCREW contains screw-type RTBs that are used for MOD power and SA power. Kit 5069-RTB64-SPRING contains spring-type RTBs that are used for MOD power and SA power.	
Current type provided	AC or DC as dictated by system design	<ul style="list-style-type: none"> System-side power - DC only Field-side power - AC or DC as dictated by system design 	<ul style="list-style-type: none"> System-side power - DC only Field-side power - DC only at the controller, AC only by using a local 5069-FPD, Field Potential Distributor module.
Special requirement	<ul style="list-style-type: none"> Must meet Power Supply Distance Rating requirements Must track power consumption in the local bank and on both sides of the power supply 	<ul style="list-style-type: none"> Must track the system-side and field-side power consumption to properly size the external power supplies that provide each power type. Must use 5069-FPD, Field Potential Distributor if SA Power consumption is exceeded before reaching max of 31 local I/O modules. Must use Field Potential Distribution module to change SA Power potential between AC and DC. 	

Project Size

The Logix Designer application uses the .ACD file format type with controller projects. The project file size does not reflect the size of your project that downloads to the controller. The .ACD file contains multiple components. Not all components are downloaded to the controller.

Configure the Controller

You must consider the best way to use controller resources when CompactLogix controllers communicate over an EtherNet/IP network. There are limitations regarding how much EtherNet/IP communication the controller supports.

Consider the following:

- Connections
- Ethernet Nodes

Connections Overview

A Logix 5000® controller provides connection resources whenever communications are established between two devices.

Connections are used when the system contains the following conditions or activities:

- I/O modules, communication modules, and adapters are present in the I/O configuration of the user project
- Produced or Consumed tags are configured in the user project
- Connected Messages are executed in the user application
- External devices, programming terminals, or HMIs communicate with the controller

Nodes on an EtherNet/IP Network

When used in a Logix Designer application project, 5380 and 5370 controllers offer a simplified method for counting controller resources.

When you configure a 5380 control system, you simply count the number of Ethernet nodes that you include in the I/O configuration section of your Logix Designer application project.

On the Controller Properties dialog box, the Logix Designer application project displays the updated number of nodes that are used as you add Ethernet nodes to the project.

To see an example of how the project displays the node count, see [Figure 24 on page 100](#).

For the EtherNet/IP node limits for 5380 and 5370 controllers, see:

- [CompactLogix Controllers on page 82](#)
- [Compact GuardLogix Controllers on page 84](#)

Devices Included in the Node Count

Any devices that you add directly to the I/O configuration section are counted toward the node limits of the controller. The following are example devices that must be counted:

- Remote communication adapters
- Devices with an embedded EtherNet/IP port, such as I/O modules, drives, and linking devices
- Remote controllers when a produce/consume connection is established between the two controllers
- HMI devices that are included in the I/O configuration tree
- Third-party devices that are directly connected to the EtherNet/IP network

Devices Excluded from the Node Count

When you calculate the EtherNet/IP node limitation of a controller, do not count devices that exist on the EtherNet/IP network but are not added to the I/O configuration section.

The following devices are **not added** to the I/O configuration section and are **not counted** among the number of nodes:

- Computer
- HMI that is not added to the I/O configuration section
- MSG instruction
- Standard Ethernet devices for which the controller uses a socket interface to communicate

New Project Dialog Box

When you create a project with a 5380 controller, the New Project dialog box appears. The dialog box provides standard controller settings, including security settings. The information that is entered in this dialog box displays on the Controller Properties General tab and Security Tab.

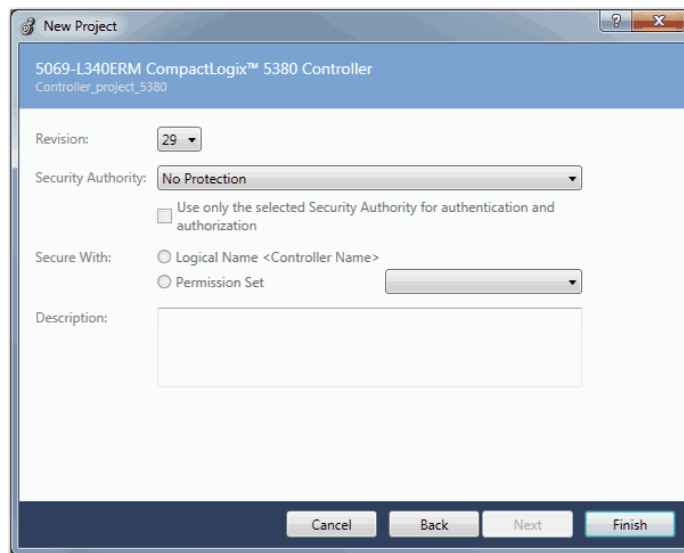

Controller Properties

This table lists Controller Properties dialog box tabs and indicates how a tab is different on a CompactLogix 5380 controller compared to a CompactLogix 5370 L3 controller.

Controller Properties Tab	Comments
General	Same functionality as the 5370 controllers.
Major Faults	Same functionality as the 5370 controllers.
Minor Faults	Same functionality as the 5370 controllers.
Date/Time	Same functionality as the 5370 controllers.
Advanced	New parameter to enable Minor Overflow fault reporting. The System Overhead Time Slice parameter was removed. For more information, see page 97 .
SFC Execution	Same functionality as the 5370 controllers.
Project	Option to download custom properties when you download project documentation and extended properties. For more information, see page 98 .
Nonvolatile Memory	Same functionality as the 5370 controllers.
Memory (Logix Designer application, version 28) Capacity (Logix Designer application, version 29 and later)	The tabs indicate the same information but are named differently between the Logix Designer application versions. Indicates data usage. Data usage is indicated with one value that combines Data and Logic memory usage and I/O memory usage. See Memory Tab on page 99 or Capacity Tab on page 100 .
Internet Protocol	Same functionality as the 5370 controllers.
Port Configuration	Same functionality as the 5370 controllers.
Network	Same functionality as the 5370 controllers.
Security	Now has additional security parameters. For more information, see page 101 .
Alarm Log	Not available for 5380 controllers in version 28. Available in version 29 or later with the same functionality as the 5370 controllers.

Advanced Tab

The Advanced tab provides a way to assign the Controller Fault Handler and Power-up Handler. You can also match a project to a specific controller by serial number. The tab is used when the project is offline.

- Report Overflow Faults is a new parameter that lets you control Minor Overflow fault reporting. When you create a project, the default setting is disabled. When you import or open a legacy project, the default setting is enabled. For more information, see [Minor Fault on Overflow on page 166](#).
- System Overhead Time Slice is no longer required for 5380 controllers, and the parameter is removed.

Figure 21 - Controller Properties Dialog Box - Advanced Tab

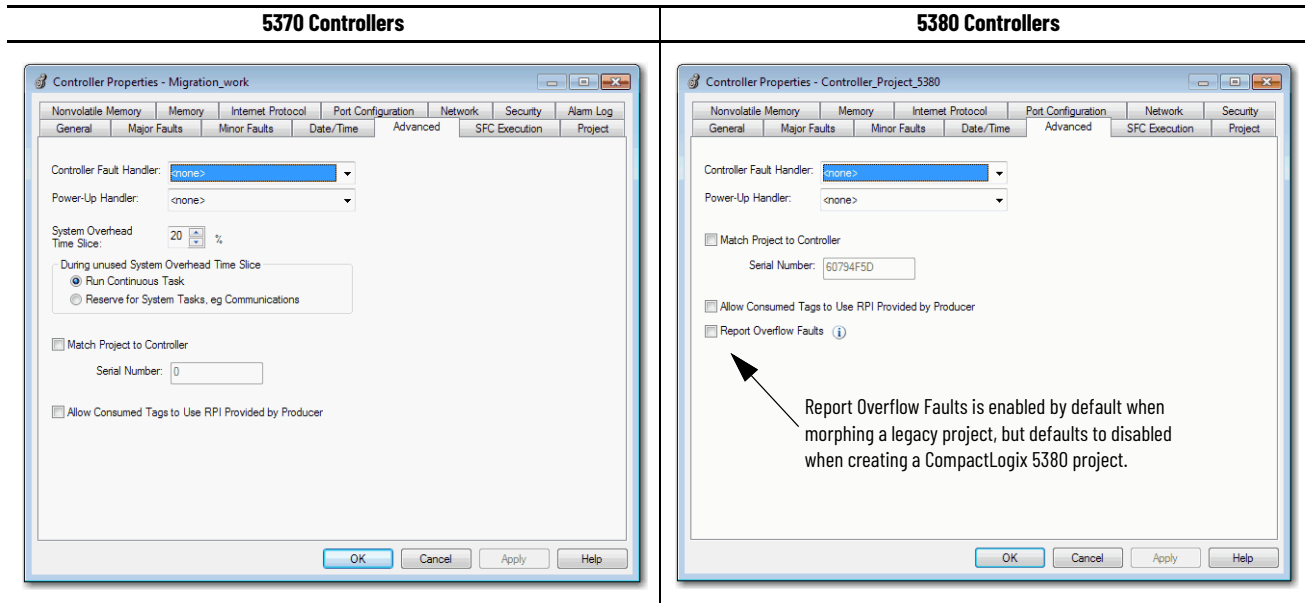

Project Tab

The Project tab provides general project information and lets you configure project download and pass-through display parameters.

The tab is used when the project is offline.

Figure 22 - Controller Properties Dialog Box - Project Tab

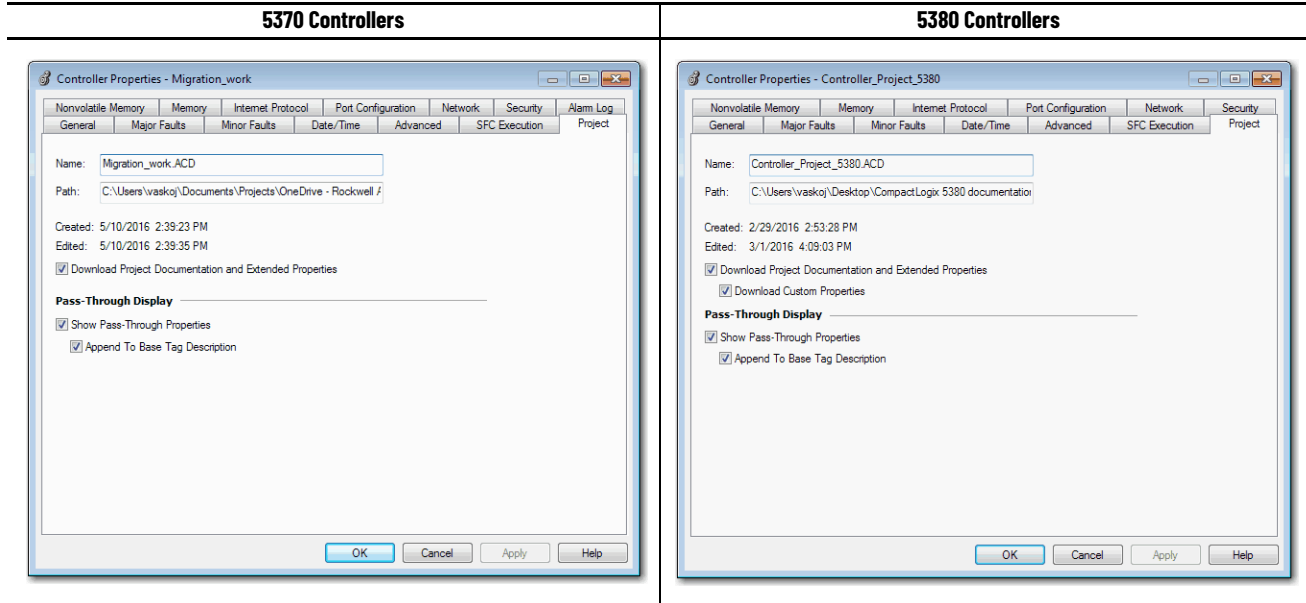

Memory Tab

In the Logix Designer application, version 28 or earlier, the Memory tab indicates data usage.

- **5370 controllers** - Data usage is indicated with two values. The tab shows I/O memory and Data and Logic memory separately.

As you change the project, you can click Estimate to see the estimated memory usage and remaining available memory.

- **5380 controllers** - Data usage is indicated with one value that combines Data and Logic memory usage and I/O memory usage.

As you change the project, the data values are automatically updated to indicate the estimated memory usage and remaining available memory.

IMPORTANT Programmatic access to memory is not supported for 5380 controllers, see [Controller Memory Usage on page 140](#).

Figure 23 - Controller Properties Dialog Box - Memory Tab

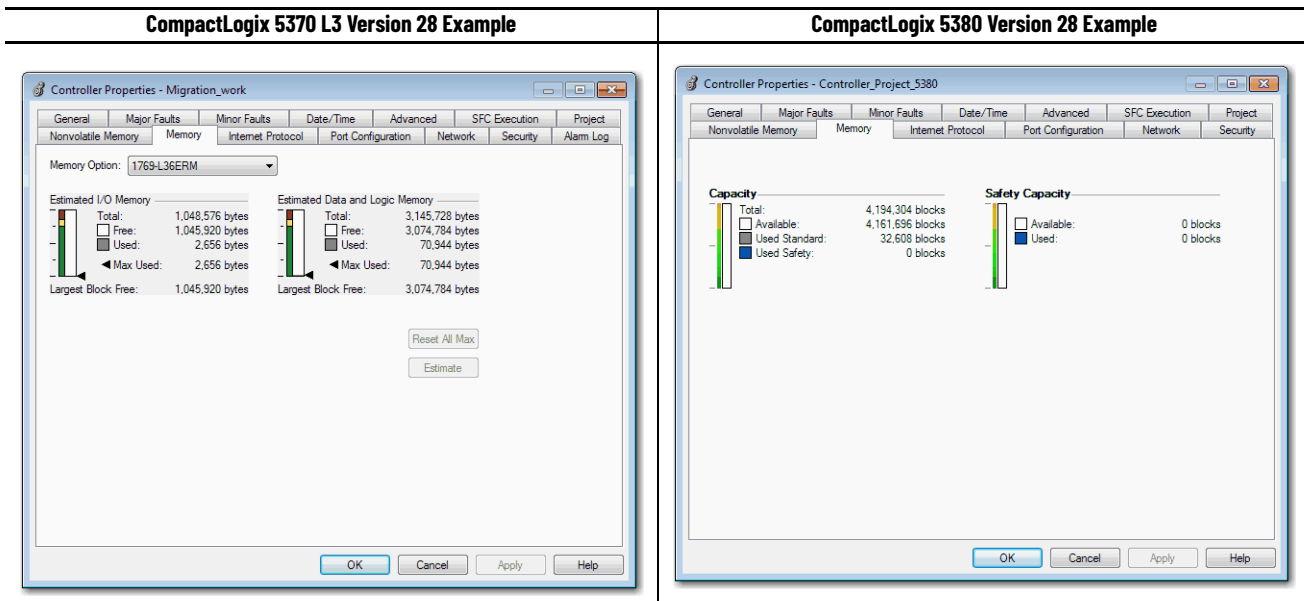

Capacity Tab

In the Logix Designer application, version 29 or later, the Capacity tab indicates data and Ethernet node usage. This tab was named Memory in previous versions of the Logix Designer application.

- 5370 controllers** - Data usage is indicated with two values. The tab shows I/O memory and Data and Logic memory separately. The tab also shows the number of Ethernet nodes that are used.

As you change the project, you can click Estimate to see the estimated memory usage and remaining available memory. The number of Ethernet nodes is updated automatically, however.

- 5380 controllers** - Data usage is indicated with one value that combines Data and Logic memory usage and I/O memory usage. The tab also shows the number of Ethernet nodes that are used.

As you change the project, the data values are automatically updated to indicate the estimated memory usage and remaining available memory. The number of Ethernet nodes is also updated automatically.

As you change the project, the data values are automatically updated.

Figure 24 - Controller Properties Dialog Box - Capacity Tab

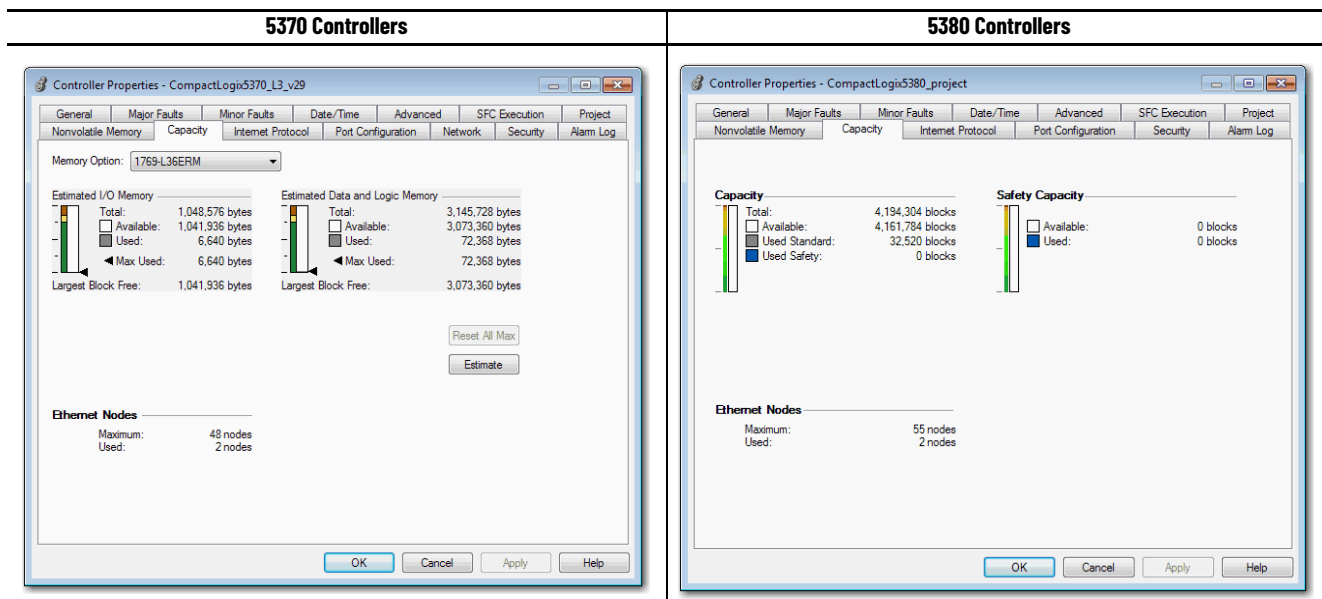

Security Tab

The Security Tab lets you see the controller security settings, for example, the Security Authority choice. Security settings are configured when you create the project.

With the Logix Designer application, version 28 or later, the controllers support additional parameters in the Security Authority section.

Figure 25 - Controller Properties Dialog Box - Security Tab

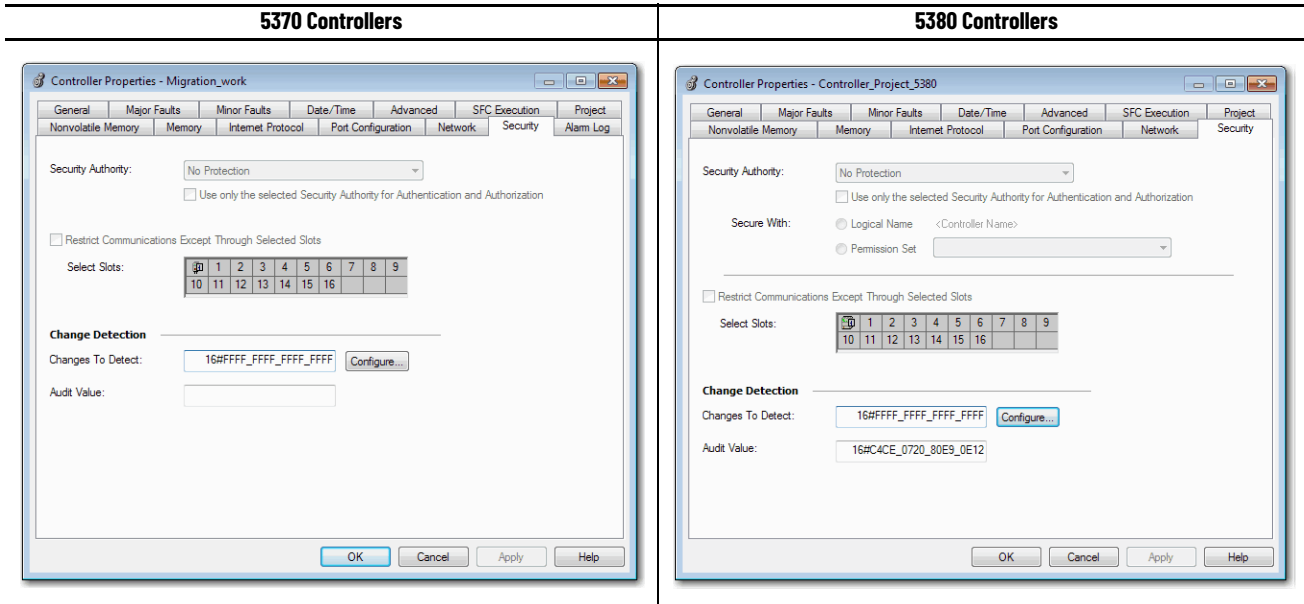

Click the Configure button to access the Configure Changes to Detect dialog box. Use the dialog box to choose the events you wish to monitor or ignore in the controller.

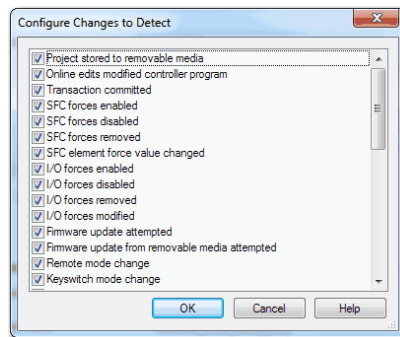

For more information on Security settings, see the FactoryTalk® Security System Configuration Guide, publication [FTSEC-0S001](#).

Controller Reset Button

You can reset the controller with the reset button behind the front door on the controller. You press the button in and hold it during a controller power-up sequence to reset the controller.



WARNING: When you press the reset button while power is on, an Electric Arc can occur. This could cause an explosion in hazardous location installations. Be sure that power is removed or the area is nonhazardous before proceeding.

Table 8 - Reset Button Descriptions

Reset Stage	Definition	5370 Controllers	5380 Controllers
Stage 1	A Stage 1 reset clears the application program and memory, but retains the IP address and all object attributes designated as non-volatile. A Stage 1 reset occurs only if the controller contains a user application.	Supported	Supported
Stage 2	A Stage 2 reset returns the controller to out-of-box settings, including firmware, and clears all network settings. A Stage 2 reset occurs only if the controller does not contain a user application, and the current controller firmware is not a 1.x revision.	Not supported	Supported

IMPORTANT

Remember the following:

- Because port enable/disable status is associated with the application program, ports become enabled after a Stage 1 reset.
- A reset occurs only when you hold the button while the module powers up. If you press the reset button during runtime, there is no effect.

Figure 26 - 5380 Controllers - Reset Button

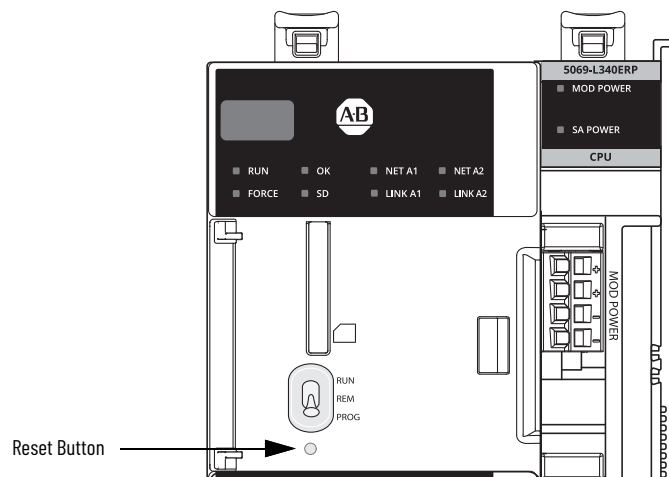

For information on how to use the reset button, see the CompactLogix 5380 and Compact GuardLogix 5380 Controllers User Manual, publication [5069-UM001](#).

SD Card Behavior

The controller has changed some behavior when loading a project from the SD card into a controller. The changes facilitate an easier commissioning of new, out-of-box controllers. All Logix 5000® controllers ship from the factory with firmware revision 1.x.

With 5380 controllers, the Load Image setting On Uninitialized Memory is available. This setting replaces the On Corrupt Memory setting that is available with 5370 controllers.

The general behavior is the same for both settings. The only difference is the controller behavior when it is in the out-of-box condition, as described in [Table 9](#).

You can install a memory card that uses On Uninitialized Memory in an out-of-box controller, that is, one that uses firmware revision 1.x. In this case, at power-up, the image loads both the controller firmware and controller application.

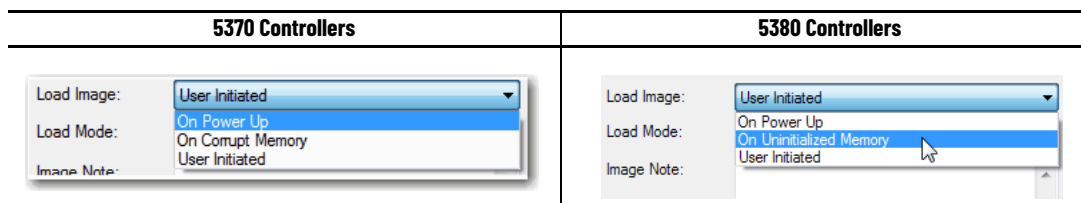

When you use a memory card with an image in an out-of-box controller (firmware revision 1.x), at power-up that controller updates its firmware to the revision stored on the card. The update occurs regardless of the Load Image setting for the image on the SD card.

The On Power Up, and On Initialized Memory settings also load the controller application into an out-of-box controller.

This table shows what happens at power-up when you insert a memory card that contains an image into a CompactLogix 5380 and Compact GuardLogix 5380 controller.

Table 9 - SD Card Settings and Controller Power-up Behavior

Image Setting	Controller is in Out-of-Box Condition (Firmware Revision 1.x)	Firmware > 1.x and Internal Nonvolatile Memory is Not Valid ⁽¹⁾	Firmware > 1.x and Internal Nonvolatile Memory is Valid ⁽¹⁾
User Initiated	Loads Firmware Only ⁽²⁾	Does Nothing	Does Nothing
On Power Up	Loads both Firmware and Application	<ul style="list-style-type: none"> Loads Firmware if there is a revision mismatch Loads Application 	<ul style="list-style-type: none"> Loads Firmware if there is a revision mismatch Loads Application
On Uninitialized Memory	Loads both Firmware and Application ⁽²⁾	<ul style="list-style-type: none"> Loads Firmware if there is a revision mismatch Loads Application 	Does Nothing

(1) "Valid" includes the No Project condition.

(2) Indicates change in behavior from CompactLogix 5370 L3 and older controllers.

Communication Options

CompactLogix 5380 and Compact GuardLogix 5380 controllers can operate on EtherNet/IP networks.

CompactLogix 5370 L3 and Compact GuardLogix 5370 L3 controllers can operate on EtherNet/IP and DeviceNet networks.

IMPORTANT Be aware of the following:

- The 5380 controllers do not support for half-duplex communications on Ethernet at any speed.

Application Type	5370 Controllers Support	5380 Controllers Support
Network communication option	<ul style="list-style-type: none"> EtherNet/IP DeviceNet via a 1769-SDN scanner 1769-ASCII module for an ASCII serial interface to RS-232, RS-422 and RS-485 devices 1769-SM2 module for a Modbus RTU serial interface MV169-MNET for Modbus TCP/IP interface 	EtherNet/IP
EtherNet/IP mode options	Can be used in linear, DLR, and star topologies. Does not support for Dual-IP mode.	<ul style="list-style-type: none"> Linear/DLR mode Dual-IP mode - Available with the Logix Designer application, version 29 or later Both modes can be used in linear, DLR, and star topologies.
Integrated Motion	EtherNet/IP	
Time Synchronization	EtherNet/IP - Available with Integrated Motion and non-motion applications	
Control of distributed I/O	<ul style="list-style-type: none"> EtherNet/IP DeviceNet 	EtherNet/IP
Produce/consume data between controllers	EtherNet/IP	
Messaging to and from other devices, including access to the controller via Logix Designer application	<ul style="list-style-type: none"> EtherNet/IP DeviceNet (only to devices) 	EtherNet/IP

Communication Throughput

Unlike 5370 controllers, which share the main core between application code and communications, the 5380 controllers run communications asynchronously from the user application.

This implementation provides better communications throughput in both the bandwidth and speed of data the 5380 controller can deliver to and from, for example, HMIs, Historians, and MES systems. It also improves the overall application performance as the controller no longer has to task switch and pause application execution to handle HMI or other class 3 traffic.

Because the controller runs communications asynchronously to the application, make sure communications that are delivered to the controller are complete before the application executes on the newly delivered data. This practice applies to both data that comes into the controller and data that goes out.

For example, if the HMI is writing a large block of recipe data to the controller, application code can start executing on that recipe data before the data writing process finishes. This action results in half of the current recipe and half of the last recipe in the application space.

Traditionally, programmers have used the following techniques to control the effects of asynchronous communications:

- UID/UIE pairs
- Periodic tasks
- Moving data with CPS instructions

The techniques all rely on controlling when the main core can switch tasks, thus helping to prevent the communications task from changing data while the control task used it. Because the 5380 controller processes communications on an independent core of the CPU, then UID/UIE pairs and Periodic Tasks are not as effective in all cases.

The items that are highlighted in this table are where 5370 and older controllers and the 5380 controllers behavior differ.

Table 10 - Behavior Differences

Tag Read/ Write Source	Tag Access					
	UID/UIE		CPS		Periodic Task	
	5380 Controllers	5370 Controllers	5380 Controllers	5370 Controllers	5380 Controllers	5370 Controllers
HMI	Allows	Blocks	Blocks	Blocks	Allows	Blocks
MSG	Allows	Blocks	Blocks	Blocks	Allows	Blocks
I/O Update	Allows	Allows	Blocks	Blocks	Allows	Allows
Produce/ Consume	Allows	Allows	Blocks	Blocks	Allows	Allows
Other User Tasks	Blocks	Blocks	Blocks	Blocks	Allows	Allows
Motion Planner	Allows	Allows	Blocks	Blocks	Allows	Allows

Blocks - Prevents source data values from changing by communications during application execution.

Allows - Communications can change source data values during application execution.

Because the 5370 and 5380 controllers have 32-bit data integrity, this only applies to data structures larger than 32 bits. If word-level integrity is your primary concern, the 32-bit data integrity does not impact your data use.

Good programming practice dictates the use of two unique words at the beginning and the end of data. The controller validates the words to assure the entire structure has data integrity. We recommend that the handshake data is changed and the application code validates it every transaction before the controller application code or higher-level system reading controller data acts on it.

EtherNet/IP Modes

With the Logix Designer application, version 29 or later, 5380 controllers support the following EtherNet/IP modes:

- [Dual-IP Mode](#)
- [Linear/DLR Mode](#)

For more information on how to use EtherNet/IP modes, see the CompactLogix 5380 and Compact GuardLogix 5380 Controllers User Manual, publication [5069-UM001](#).

Dual-IP Mode

With the Logix Designer application, version 29 or later, you can use Dual-IP mode.

Dual-IP mode lets you configure the controller embedded Ethernet ports to connect to separate networks, that is, an enterprise-level Ethernet network and a device-level network.

The following graphic shows a CompactLogix 5380 controller that uses Dual-IP mode in a star topology.

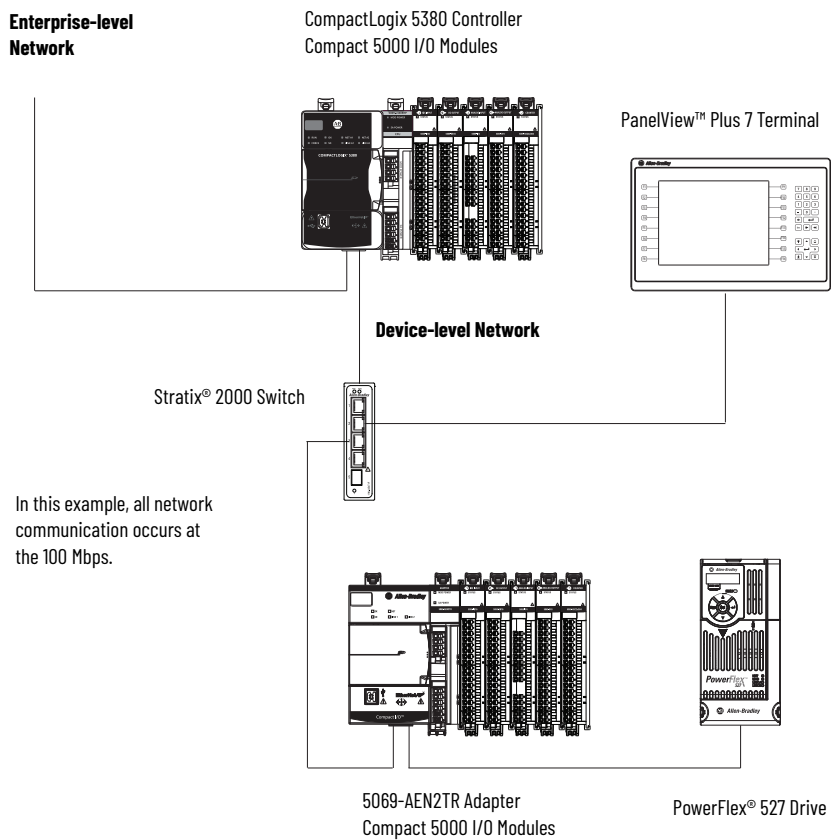

Linear/DLR Mode

When the controllers operate in Linear/DLR mode, they can only connect to one network and have only one network configuration. The controllers can connect to any EtherNet/IP topology.

In this example, all network communication occurs at the 100 Mbps.

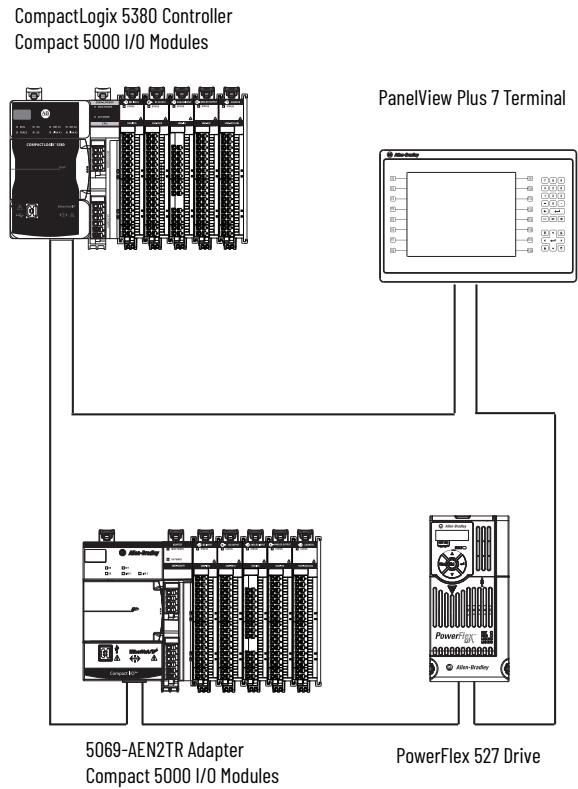

Use Compact I/O and Compact 5000 I/O Modules in CompactLogix Systems

You can use local and remote I/O modules with the controllers.

The following is information about how you can use I/O modules in different applications.

	5370 Application	5380 Application
Local I/O modules	1769 Compact I/O modules across up to three banks	Compact 5000 I/O modules in one bank
Number of local I/O modules supported, max	<ul style="list-style-type: none"> 1769-L30ER, 1769-L30ER-NSE, 1769-L30ERM, 1769-L30ERMS: 8 1769-L33ER, 1769-L33ERM, 1769-L33ERMS: 16 1769-L36ERM, 1769-L36ERMS: 30 	<ul style="list-style-type: none"> 5069-L306ER, 5069-L306ERS2, 5069-L306ERM, 5069-L306ERMS2, 5069-L306ERMS3, 5069-L310ER, 5069-L310ERS2, 5069-L310ER-NSE, 5069-L310ERM, 5069-L310ERMS2, 5069-L310ERMS3: 8 5069-L320ER, 5069-L320ERS2, 5069-L320ERM, 5069-L320ERMS2, 5069-L320ERMS3, 5069-L320ERP: 16 5069-L330ER⁽¹⁾, 5069-L330ERS2, 5069-L330ERM, 5069-L330ERMS2, 5069-L330ERMS3, 5069-L340ER, 5069-L340ERS2, 5069-L340ERM, 5069-L340ERMS2, 5069-L340ERMS3, 5069-L340ERP, 5069-L350ERS2, 5069-L350ERM, 5069-L350ERMS2, 5069-L350ERMS3, 5069-L380ERM, 5069-L380ERMS2, 5069-L380ERMS3, 5069-L3100ERS2, 5069-L3100ERM, 5069-L3100ERMS2, 5069-L3100ERMS3: 31
Installation location of local I/O modules	Across as many as three banks, the bank containing the controller and two expansion banks	Same bank as the controller
Installation orientation of local I/O modules	<ul style="list-style-type: none"> I/O modules are only installed in the local bank - Horizontal only I/O modules are installed in multiple banks - Horizontal or vertical 	Horizontal only
Spacing on all sides of system, min For more information see, Controller Spacing on page 86	50 mm (2 in.) of space on all sides	<p>Varies based on the operating temperature:</p> <p>Compact GuardLogix 5380 SIL 2 Series A catalog numbers:</p> <ul style="list-style-type: none"> 50.80 mm (2.00 in.) at 50 °C (131 °F) 101.60 mm (4.00 in.) at 55 °C (122 °F) 152.40 mm (6.00 in.) at 60 °C (140 °F) <p>Compact GuardLogix 5380 SIL 2 Series B catalog numbers:</p> <ul style="list-style-type: none"> 50.8 mm (2.00 in.) at 55 °C (131 °F) 101.6 mm (4.00 in.) at 60 °C (140 °F) <p>Compact GuardLogix 5380 SIL 3 catalog numbers:</p> <ul style="list-style-type: none"> 50.8 mm (2.00 in.) at 55 °C (131 °F) 101.6 mm (4.00 in.) at 60 °C (140 °F)
Remote I/O modules	Accessible over the following: <ul style="list-style-type: none"> EtherNet/IP network DeviceNet network via 1769-SDN adapter The controllers cannot access Compact 5000 I/O.	Accessible over an EtherNet/IP network For optimal CompactLogix 5380 control system performance, we recommend that you use Compact 5000 I/O modules as the remote I/O modules.
Special considerations	<ul style="list-style-type: none"> Consider the number and type of 1769 Compact I/O modules in a system when you set the requested packet interval (RPI) rate Track collective system power use by the local I/O modules Consider the power supply distance rating when you plan the slot location for local I/O modules 	Track collective SA power use by the local I/O modules in a system

(1) When you use this controller with the Logix Designer application, version 29.00.00, the application limits the number of local I/O modules in the project to 16. For more information, see Knowledgebase Article [CompactLogix controllers limited to 16 local 5069 modules in V29 of Studio 5000®](#).
 With the Logix Designer application, version 30.00.00 or later, the controller supports as many as 31 local I/O modules.

CompactLogix 5370 L3 System

The following shows I/O modules that are used in CompactLogix 5370 L3 system.

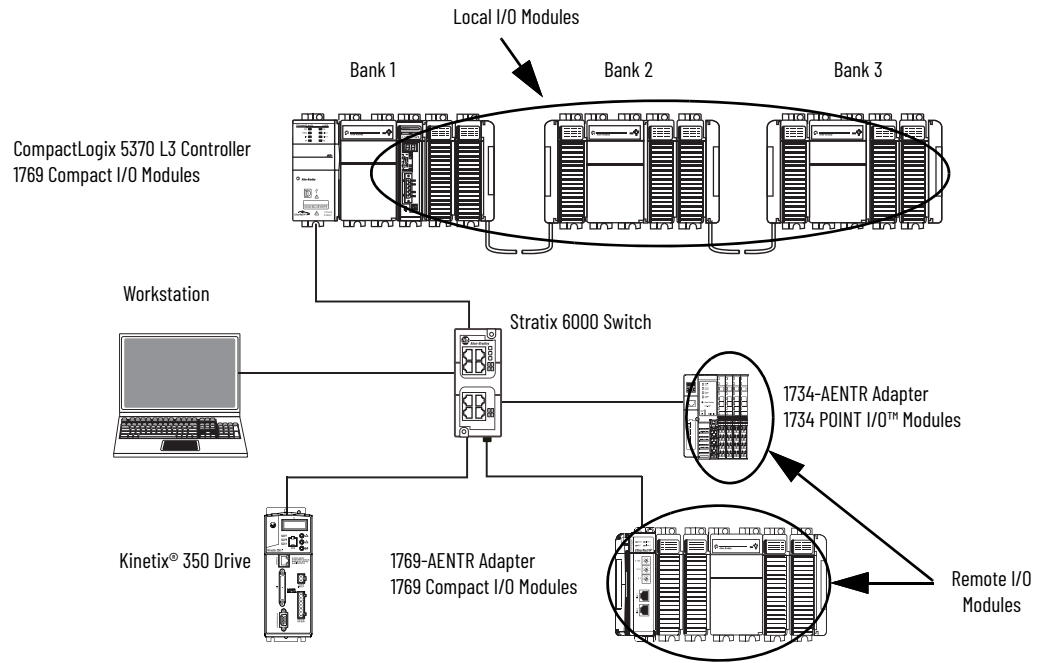

CompactLogix 5380 System

The following shows I/O modules in a CompactLogix 5380 system.

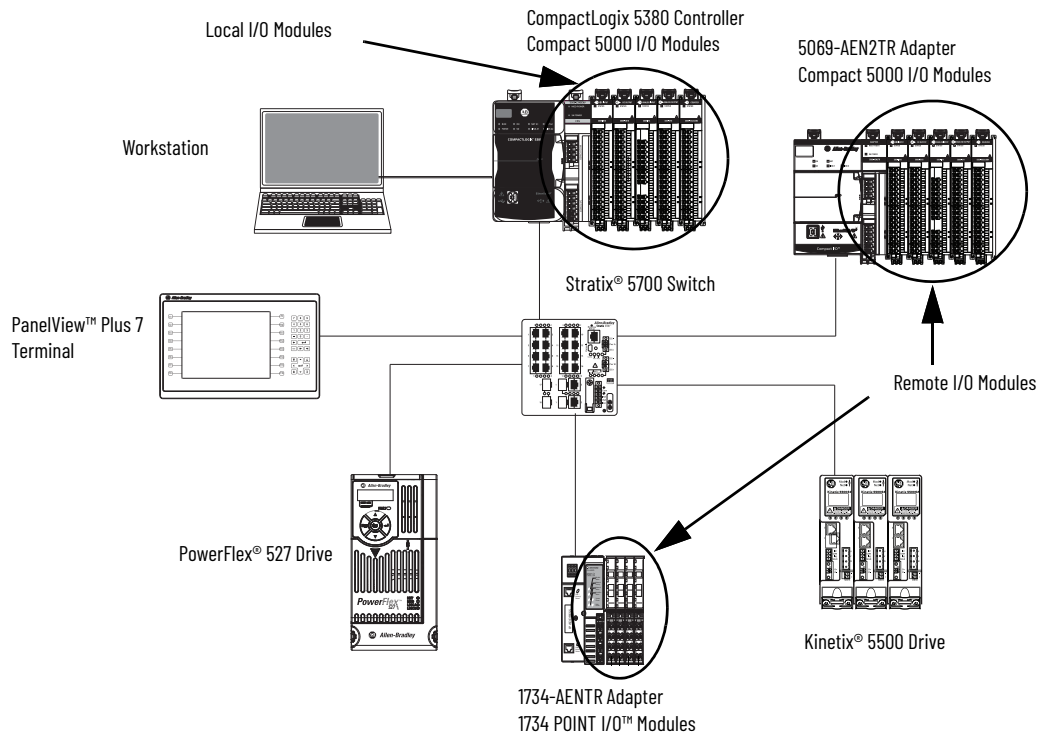

Local I/O Module Performance

Local I/O module performance is significantly improved in 5380 systems when compared to 5370 systems. The improved performance results from the following:

- A high-performance, multi-core processor architecture
- High-speed Compact 5000 I/O system backplane supports faster transfer rates

In 5370 systems, local I/O module updates are transferred to the controller via the 1769 CompactBus at the specified requested packet interval (RPI). The controller uses a dedicated I/O task to update internal I/O tag data. The task is internally set to a priority of level 6. You must carefully arrange user task priorities so that important local I/O updates are not interrupted by scanning of lower-level tasks in the controller.

With the high-performance 5380 controller, you are no longer required to arrange task priorities around the dedicated I/O task. The I/O tag data is updated as part of an internal task on its own processor core and does not affect the user tasks running on the controller processor core.

System performance is also improved because you can configure much faster RPI rates with Compact 5000 I/O modules. For example, you can configure the RPI to occur as fast as every 200 μ s. You cannot use the same rate with the 1769 Compact I/O modules that are used in 5370 systems.

Finally, the backplane is optimized to move larger amounts of data in one packet than is possible on the 1769 CompactBus backplane.

Logix 5000 controllers still scan for I/O updates at the RPI asynchronously to the program scan. The 5380 system handles controller multi-tasking and I/O updates more efficiently and faster than 5370 systems, though. The enhanced performance results from improvements to the architecture, hardware, and system backplane.

When you use 5380 systems, there are fewer configuration considerations and a much better screw-to-screw I/O performance compared to 5370 systems that use local 1769 Compact I/O.

Event Task Triggers

You can use event task triggers in 5380 systems to optimize local I/O performance and screw-to-screw times. An event task, if configured correctly, interrupts all other tasks for the minimum amount of time that is required to respond to the event.

You can now configure event triggers on I/O data change of state with Compact 5000 I/O fast input modules. This option is not available with 5370 controllers because the 1769 Compact I/O modules do not support event triggers on I/O data change of state. If the controller executes the Immediate Output instruction (IOT) at the end of the event task, the output data is transmitted immediately. The controller does not have to wait for processing at the next RPI.

The table shows an updated comparison of event triggers with 5380 and 5370 controllers. Consult Logix 5000 Controllers Tasks, Programs, and Routines Programming Manual, publication [1756-PM005](#).

Controllers	Event task triggers supported					
	Module Input Data State Change	Consumed Tag	Axis Registration 1 or 2	Axis Watch	Motion Group Execution	EVENT instruction
5370 controllers		X	X	X	X	X
5380 controllers	X	X	X	X	X	X

For more information on how to use event triggers with Compact 5000 I/O fast input modules, see the 5000 Series Digital I/O Modules in Logix 5000 Control Systems User Manual, publication [5000-UM004](#).

Scheduled Outputs

New with 5380 controllers and Compact 5000 I/O fast modules is the option to schedule outputs and time stamp inputs to a grandmaster clock within a CIP Sync™ system. CIP Sync technology supports highly distributed applications that require the following:

- Timestamping
- Sequence of Events recording
- Distributed motion control
- Increased control coordination

This level of control is not available with 5370 controllers because you cannot configure 1769 Compact I/O modules with scheduled outputs or timestamped inputs.

For more information on how to use scheduled outputs with Compact 5000 I/O fast output modules, see the 5000 Series Digital I/O Modules in Logix 5000 Control Systems User Manual, publication [5000-UM004](#).

You can use the following to obtain an ideal midrange solution for applications that use Integrated Motion Over an EtherNet/IP network:

- 5380 controllers
- Compact 5000 I/O fast I/O modules
- Kinetix® 5500 servo drives

Download the Program to the Controller

The first time that you download a program, it can take longer than subsequent downloads. These situations can affect download/compile times:

- The capability of the personal computer or laptop.
- You download the project immediately after a project import or upload, but before Logix Designer has compiled the project once.
- You edit a User Defined Tag (UDT), Add-On Instruction (AOI), or an object that is used in many places.
- Increased load when Logix Designer compiles and generates code.

Build Button

The new Build button in Logix Designer creates binary files that are compiled from user subroutines, and caches them in the project .ACD file.



If these files are present in the project during a download, then Logix Designer does not have to recompile them, and saves time during the download process.

Every download requires that only the changed subroutines must be recompiled. You can perform a build offline, save the project .ACD file, and later distribute it to many controllers without recompilation.

This manual build step is optional. If you do not use the build button, Logix Designer builds all necessary files when you initiate a download.

An imported project requires a complete rebuild, and extends the download process the first time you attempt a download.

[Downloading Workflow Change on page 112](#) provides an explanation of the download changes for 5380 controllers.

Downloading Workflow Change

Offline builds can save time when doing subsequent downloads.

5380 Controllers	5370 Controller
Only changed source code is recompiled on a download.	All projects had their source code recompiled on every download.

Mitigation

Adjust your workflow to save workstations from having to rebuild the project. You can do offline builds, save the project file, and distribute it to other workstations to minimize your download times.

Upload Fidelity Change

When you upload, projects that contain program parameters and aliases now are faithfully reproduced. The uploaded RLL source code is an exact replica of what was downloaded. 5370 controller RLL subroutines that referenced aliases or program parameters are not reproduced as faithfully.

Thermal Monitoring and Thermal Fault Behavior

The controllers monitor internal module temperatures and respond as the temperature increases.

Figure 27 - Thermal Fault Behavior

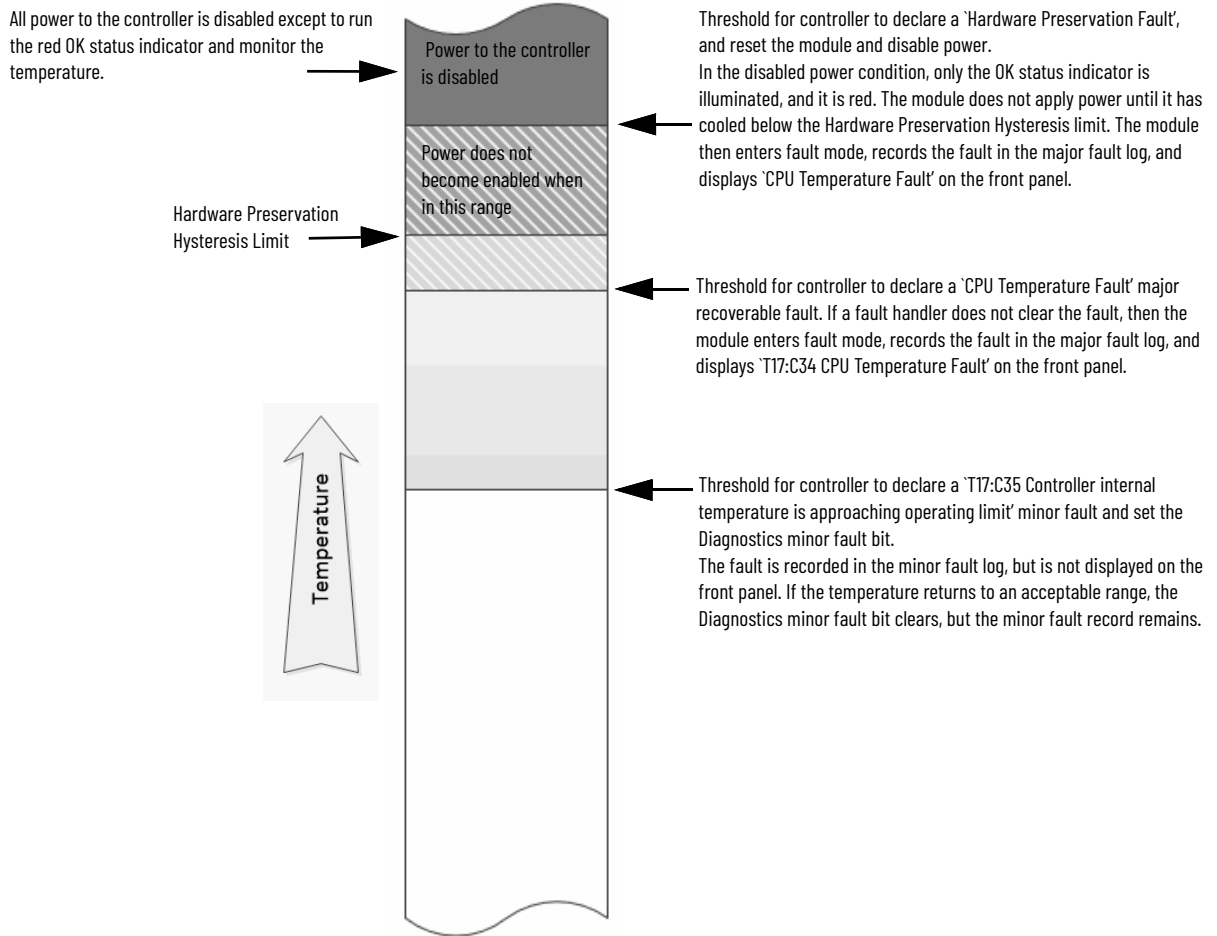

Notes:

Replacement Considerations with Safety Applications

This chapter describes features and functions that are associated with the ControlLogix 5590, GuardLogix® 5580, and Compact GuardLogix 5380 controllers, and the differences in safety functionality from previous safety controllers.

IMPORTANT	<p>In this chapter:</p> <ul style="list-style-type: none"> • “Compact GuardLogix 5380 controllers” refers to both Compact GuardLogix 5380 SIL 2 and Compact GuardLogix 5380 SIL 3 controllers. • References to ControlLogix 5590 assume that the controllers are safety-enabled.
------------------	--

Perform Risk Assessment

A proper safety strategy consists of risk assessment and risk reduction.

- Risk Assessment – understand the machine limits and functions and tasks that may be required to be performed at the machine throughout its life.
- Risk Reduction – performed if necessary and safety measures are selected based on the information derived from the risk assessment stage. The manner in which this is done is the basis of the Safety Strategy for the Machine.

For guidance on how to assess the impact of a product change as part of the risk assessment process, see IEC 61508 Part 1:2010, Section 7.16 (Overall modification and retrofit).

See the Machinery Safebook 5 - Safety Related Control Systems For Machinery Reference Manual, publication [SAFEBK-RM002C-EN-P](#).

Firmware Upgrade Guidelines for Safety Controllers

IMPORTANT	<p>Safety Consideration</p> <p>You cannot update a controller that is safety locked.</p>
------------------	--

The IEC 61508 functional safety standard requires impact analysis before upgrading or modifying components in a certified, functional safety system. This section provides high-level guidance on how you can perform the impact analysis for safety controller hardware/ firmware upgrades. Reference the standard to make sure you fulfill all of the requirements as they relate to your application.

When you upgrade controller firmware to a newer version, consider the following:

- All major and minor firmware releases for ControlLogix 5590, GuardLogix 5580 and Compact GuardLogix 5380 controller systems are certified for use in safety applications. As part of the certification process, Rockwell Automation tests the safety-related firmware functions (for example the CIP Safety™ communication subsystems, embedded safety instruction execution, and safety-related diagnostic functions). The firmware release notes identify changes to safety-related functions.
- Perform an impact analysis of the planned firmware upgrade.
 - Review of the firmware release notes for changes in safety-related functionality.
 - Review of hardware and firmware compatibility in the Product Compatibility and Download site to identify potential compatibility conflicts.
 - Any modification, enhancement, or adaptation of your validated software must be planned and analyzed for any impact to the functional safety system as described in the 'Edit Your Safety Application' section in the safety reference manual for your controller.
- You must remove and re-generate the safety signature as part of the firmware upgrade process. Use the online and offline edit process described in the safety reference manual for your controller.

For more controller-specific information, see the following:

- ControlLogix 5590 Controllers User Manual, publication [1756-UM900](#)
- GuardLogix 5580 and Compact GuardLogix 5380 Safety Reference Manual, publication [1756-RM012](#).

IMPORTANT ControlLogix 5590, GuardLogix 5580, and Compact GuardLogix 5380 controllers have a different compiler than earlier controllers. You must revalidate that applications on earlier controllers compile correctly on ControlLogix 5590, GuardLogix 5580 and Compact GuardLogix 5380 controllers.

For product change management guidelines and definitions of how Rockwell Automation manages product versions, see System Security Design Guidelines Reference Manual, publication [SECURE-RM001](#).

For Example:

1. From the Product Compatibility and Download Center:
 - a. Review all firmware release notes, starting with the original firmware revision through the new firmware revision, to identify any changes that impact the safety-related implementation of the application.
 - b. Review hardware and firmware compatibility to identify any restrictions between the original system components and the new system components.
2. Perform a hazard and risk assessment for any changes identified during the impact analysis and determine what additional testing is necessary.
3. Perform the online and offline edit process described in the safety reference manual for your controller. You can restrict the 'Test the Application' block to the testing identified by the hazard and risk assessment.

Applications with 1734-AENTR Series A Modules

Safety Signature

If your system includes 1734-AENTR Series A modules and you update to a GuardLogix 5580 controller, reconnection events can result in a failure to connect. The modules display error code 16#203 (connection time out) or 16#117 (invalid connection POINT). Rockwell Automation recommends that you upgrade to 1734-AENTR Series B or later modules.

The safety signature consists of an ID number, date, and time that uniquely identifies the safety portion of a project. This signature includes safety logic, data, and configuration.

- Compact GuardLogix 5370 and GuardLogix 5570 controllers in SIL1 or SIL2 configuration did not require safety signature.
- Compact GuardLogix 5370 and GuardLogix 5570 controllers in a SIL3 configuration, required a safety signature.
- For Compact GuardLogix 5380 and GuardLogix 5580 controllers in a SIL2 configuration (safety controller only), a safety signature is required for up to SIL2.
- For GuardLogix 5580 controllers in a SIL3 configuration (primary safety controller and separate safety partner), a safety signature is required.
- For Compact GuardLogix 5380 SIL 3 Controllers (safety controller with internal safety partner), a safety signature is required.

For Compact GuardLogix 5380 and GuardLogix 5580 controllers, the safety signature ID is now 256-bit.

Compact GuardLogix 5370 and GuardLogix 5570 Controllers Safety Signature ID	Compact GuardLogix 5380 and GuardLogix 5580 Controllers Safety Signature ID
	

GSV of Safety Attributes

The two attributes below generate errors when imported into a Compact GuardLogix 5380 or GuardLogix 5580 Controller project. These attributes no longer exist in the Compact GuardLogix 5380 and GuardLogix 5580 Controllers.

Compact GuardLogix 5370 and GuardLogix 5570 Controllers only

SafetySignatureID (DINT)	32-bit identification number
SafetySignature (String)	ID number plus date and time stamp

SafetySignatureID is changed to SafetySignatureIDLong or SafetySignatureIDHex in the Compact GuardLogix 5380 and GuardLogix 5580 Controllers.

Compact GuardLogix 5380 and GuardLogix 5580 Controllers only

SafetySignatureIDLong (SINT [33])	The first byte is the size of the safety signature ID in bytes, and the remaining 32 bytes contain the content of the 32-byte safety signature ID.
SafetySignatureIDHex (String)	64 character hexadecimal string representation of the safety signature ID.
SafetySignatureDateTime (String)	27 character date time of a safety signature in the format of mm/dd/yyyy, hh:mm:ss.iii<Am or PM>

This example shows the SafetySignature after the import, and what to change it to.

1. Compact GuardLogix 5370 and GuardLogix 5570 controllers have a safety attribute called SafetySignature. Since this attribute does not exist in Compact GuardLogix 5380 and GuardLogix 5580 controllers, this is how the rung appears after the import.



2. When you change the SafetySignature attribute to the SafetySignatureDateTime attribute, the rung compiles.



Safety Signature in Run Mode

With firmware revision 38.011 or later, safety controllers can be in Remote Run, Program/Remote Program or Remote Test mode to generate a safety signature.

With firmware revision 37 or earlier, the controllers must be in Program/Remote Program mode to generate a safety signature.

Safety Level Configuration

In Logix SIS applications, the safety level on the Safety tab of the Controller Properties dialog box, must be set appropriately for the firmware revision that you are using.

Logix Designer Application Version	Safety Level
38 or later	SIL2/PLd when disqualified. SIL3/PLe when synchronized or disqualified within MRT
37	SL2/PLd

IMPORTANT

- With firmware revision 38 or later, the GSV SafetySIL Configuration attribute always shows a SIL 3 value even when your system complies with a SIL 2 safety function.
- With firmware revision 37, the GSV SafetySIL Configuration attribute always shows a SIL 2 value even when your system complies with a SIL 3 safety function. A SIL2/PLd safety level is the required configuration for controllers that are enabled for redundancy.

Safety Network Number

The safety network number (SNN) uniquely identifies CIP Safety™ subnets within a routable safety network. The combination of the SNN + Node Address uniquely identifies each CIP Safety port on each device in the routable safety network.

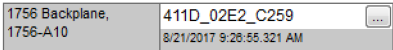
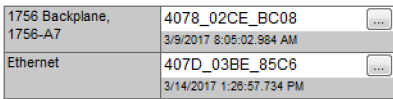
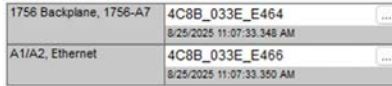
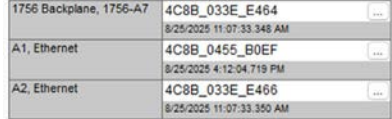
GuardLogix 5570	GuardLogix 5580	ControlLogix 5590 (safety-enabled)
 <p>GuardLogix 5570 controllers have one SNN for the backplane communications.</p>	 <p>The GuardLogix 5580 requires two SNNs, one for the embedded Ethernet port, and one for the backplane communications</p>	 <p>When operating in Linear/DLR mode, the 5590 controller requires two SNNs, one for the embedded Ethernet port, and one for the backplane communications</p>  <p>When operating in Dual-IP mode, the 5590 controller requires three SNNs, two for the embedded Ethernet ports, and one for the backplane communications</p>

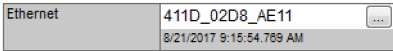
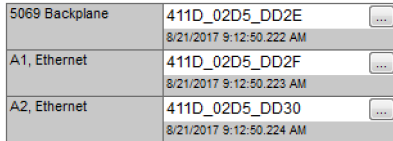
Compact GuardLogix 5370	Compact GuardLogix 5380
 <p>Compact GuardLogix 5370 controllers have one SNN for the embedded Ethernet ports.</p>	 <p>The Compact GuardLogix 5380 controllers have a SNN for each embedded Ethernet port, and one for the backplane communications</p>

For an explanation of the Safety Network Number, see the GuardLogix 5580 and Compact GuardLogix 5380 Controller Systems Safety Reference Manual, publication [1756-RM012](#).

Produce/Consume Safety Tags

GuardLogix 5580 and Compact GuardLogix 5380 controllers can produce standard tags as unicast or multicast, but they can only produce safety tags as unicast. The controllers can consume safety tags as either unicast or multicast.

When you configure a produced safety tag, you are only allowed to configure unicast connection options. Studio 5000 Logix Designer® does not allow you to configure multicast connection options.

When you configure a consumed tag, you must consider the capabilities of the producer:

- If the producer in the I/O tree of this controller is a GuardLogix 5580 or Compact GuardLogix 5380 controller, and you are consuming a safety tag, you must configure the consumed tag to use unicast.
- If the producer in the I/O tree of this controller is a GuardLogix 5570 or 5560 controller, or a Compact GuardLogix 5370 controller, the safety consumed tag can be configured as either unicast or multicast.
- Produce/Consume from GuardLogix 5570 (V28) to GuardLogix 5570 (V28) in local chassis; and change the Producer to GuardLogix 5580 (SIL2 or SIL3)
- The GuardLogix 5580 can only produce safety tags that use Unicast connections. An older safety controller (such as GuardLogix 5570) in the same chassis as the GuardLogix 5580 will not be able to consume safety tags, because backplane consumed tags cannot be configured as Unicast.
- For multi-controller Produce/Consume safety systems in the same chassis, you must upgrade all the safety controllers to Studio 5000 Logix Designer version 31 or later. This works because V31 allows the backplane safety consumed tags to be configured as Unicast.

The fault code for these unicast/multicast issues is Code 0124 / Connection Request error / Invalid input network connection type.

Safety Application Conversion

When you import a Logix Designer project that was created in an earlier version of Logix Designer application, the project is converted to the later version.

IMPORTANT The standard side of Compact GuardLogix 5380 and GuardLogix 5580 controllers operate the same as standard CompactLogix™ 5380 and ControlLogix® 5580 controllers.

The other chapters in this publication cover the standard side of the controllers. Before you convert your safety application, make sure you read and understand the rest of the chapters in this publication.

Compact GuardLogix 5380 Controllers

- During import from Compact GuardLogix 5370 to Compact GuardLogix 5370 version 31 application; the application remains a SIL3 project.
- When you change the controller from Compact GuardLogix 5370 to Compact GuardLogix 5380, 1769 modules will be deleted, since 1769 modules no longer communicate to Compact GuardLogix 5380 controllers.
- For a Compact GuardLogix 5380 SIL 2 controller, the project also changes from a SIL 3 project in 5370 to a SIL 2/PLD project (only SIL 3 is possible in Compact GuardLogix 5370).
- For a Compact GuardLogix 5380 SIL3 controller, the SIL 3 project in 5370 remains a SIL3 project in 5380.
- The safety signature is deleted during the application conversion.

GuardLogix 5580 Controllers

- During import from GuardLogix 5570 (V20 to V30) to GuardLogix 5570 V31, it remains a SIL3 project. The safety controller and safety partner remain in the same two slots.
- When you change the controller from GuardLogix 5570 to GuardLogix 5580, it remains a SIL3 project. To change the GuardLogix 5580 from a SIL3 to SIL2 project, just change the safety level in the safety tab. The application then deletes the safety partner.
- The safety signature is deleted during the application conversion.

Exporting and importing Safety Add-on Instructions

To help optimize the internal memory structures:

- Import the version 30 or earlier project from an ASCII.L5K or an XML .L5X file to create the version 31 or later project.
- Import rungs, routines, programs, equipment phases, UDTs, tags, and Add-On Instructions into a version 31 or later project.

For more information on how to import your project, see:

- Logix 5000® Controllers Import/Export Reference Manual, publication 1756-RM084.
- Logix 5000 Controllers Import/Export Project Components Programming Manual, publication 1756-PM019.

Convert a Safety Application

To convert from a Compact GuardLogix 5370 or GuardLogix 5570 controller to a Compact GuardLogix 5380 or GuardLogix 5580 controller, follow this procedure:



The example in this procedure converts a 1756-L72S controller to a 1756-L84ES controller.

1. Export the project to an ASCII .L5K or XML .L5X file.

In a pre-version 31 Release, export the project to an ASCII .L5K or XML .L5X file. You can only export a project if you have the project file open.

- c. From the File menu, choose Save As.

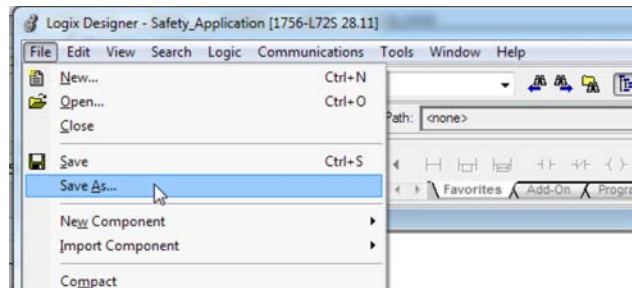

- d. In the File name field, enter a name for the export file. You do not need to add a file extension, but if you do, you must use the .L5K extension.

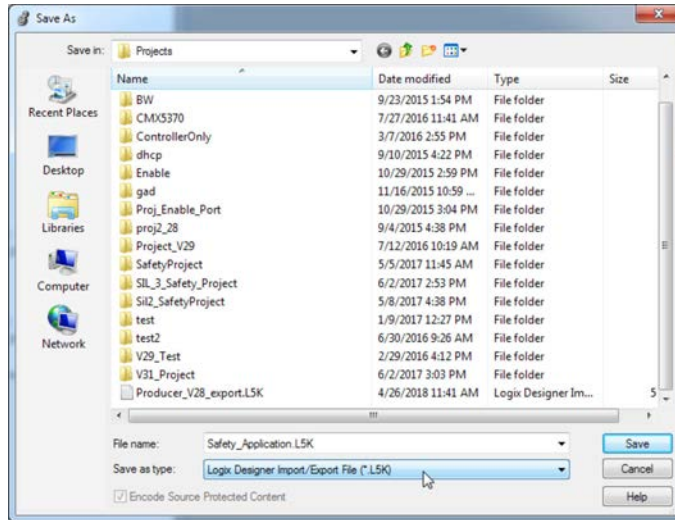

- e. Choose Logix Designer Import/Export File (*.L5K, .L5X) from the Save As Type field. Note that you can skip this step if you entered the extension (.L5K or .L5X) in step b.
- f. Click Save to export the project file.

IMPORTANT

- If you are offline, and there are one or more properties dialog boxes with pending edits, the edits are automatically applied.
- If you are online, you are prompted to apply the edits.
- If you are online, you are prompted to upload tag values from the controller before exporting. This allows you to decide whether you want the current tag values exported.
- If Force Masks are set in your project, they are exported. Upon import, any Force Masks are input to the project, and the Online Bar indicator is set to Forces Installed.
- The state of the Online Bar Forces Enabled indicator is not exported; upon import, it is set to Forces Disabled. We do not recommend editing force values in the export file.

2. Import the project from an ASCII .L5K or an XML .L5X file into Studio 5000 Logix Designer version 31.00.00 or later.
- a. Launch the Studio 5000 Logix Designer application version 31.00.00 or later.
- b. Choose Create > From Import.



c. Select the project file you want to open.

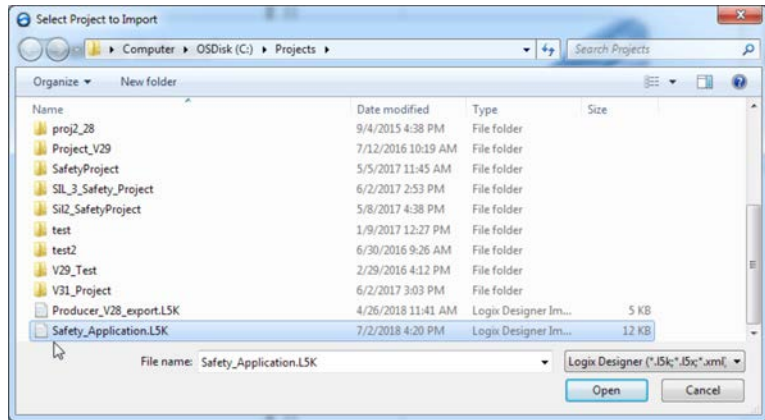

d. Click Open.

e. The Save Imported Project As dialog opens.

The import process must create a project file - you must specify the name, location and revision of the project file to create.

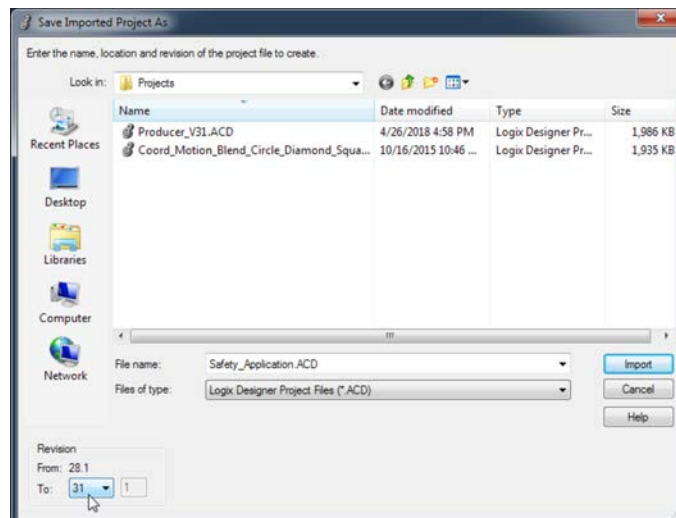

- f. Click Import to open the project file.

Once the project file is opened, the Controller Organizer appears, and shows everything in the controller as of the time when the project file was last saved.

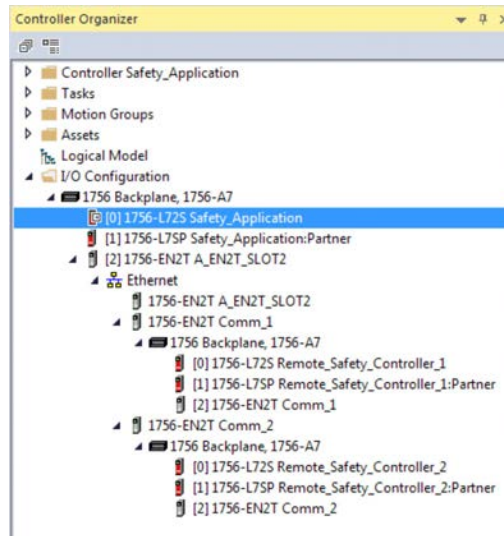

IMPORTANT If you import an .L5K or .L5X file that contains Serial Port, DF1, or ASCII elements into a project that uses a controller with no serial ports results in an import error. The import then continues to completion.

3. Change the GuardLogix 5570/Compact GuardLogix 5570 controller to a GuardLogix 5580/Compact GuardLogix 5380 controller.

IMPORTANT

- If you change from a GuardLogix 5570 safety controller with a SIL 3/PLe application to a Compact GuardLogix 5380 controller, the application changes to SIL 2/PLd.
- If you change from a GuardLogix 5570 safety controller with a SIL 3/PLe application to a Compact GuardLogix 5380 SIL 3 controller, the application remains SIL 3/PLe.
- If you change from a GuardLogix 5570 safety controller with a SIL 3/PLe application to a GuardLogix 5580 controller, it defaults to a SIL 3/PLe configuration. The safety controller and safety partner remain in the same two slots in the I/O tree. If you want to change the GuardLogix 5580 from a SIL 3/PLe to SIL 2/PLd safety project, then change the safety level in the Safety tab on the Controller Properties dialog box.

a. Open the Controller Properties, and click Change Controller.

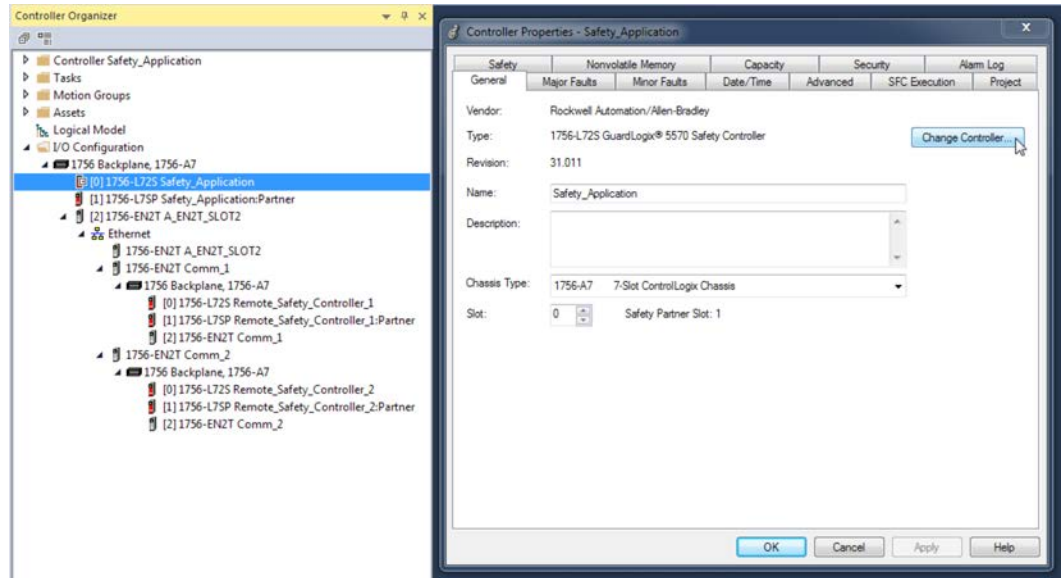

b. Select your safety controller in the Change Controller dialog box, and click OK.

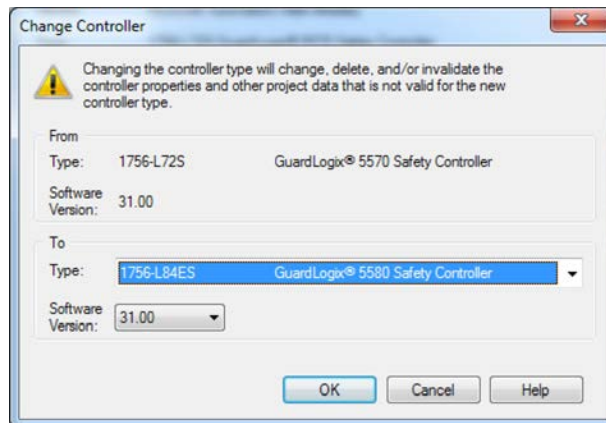

- c. On the confirmation dialog, read the and be aware of the warning messages.
- d. On the confirmation dialog, click Yes.

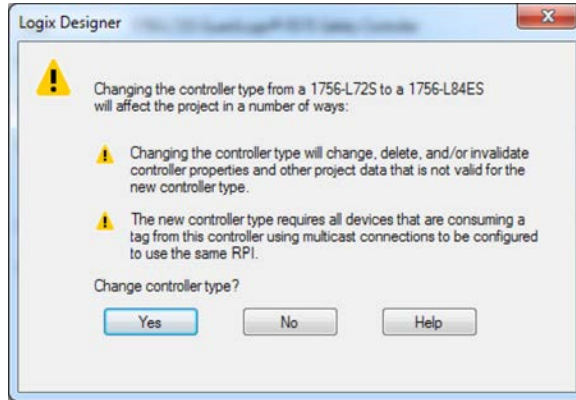

- e. Verify Errors and Warnings.

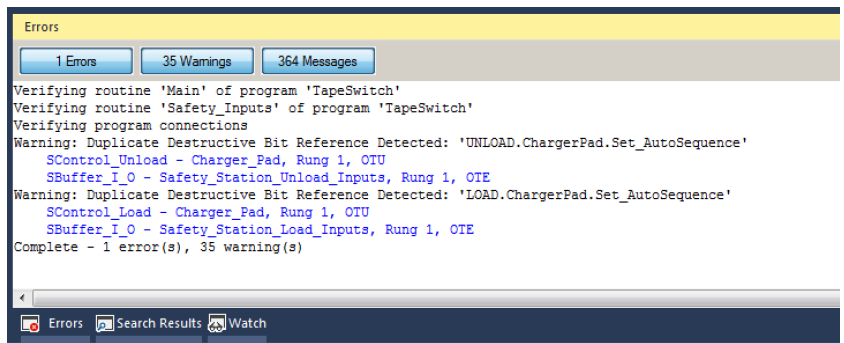

- f. The 1756-L84ES safety controller retains the SIL 3/PLe configuration.

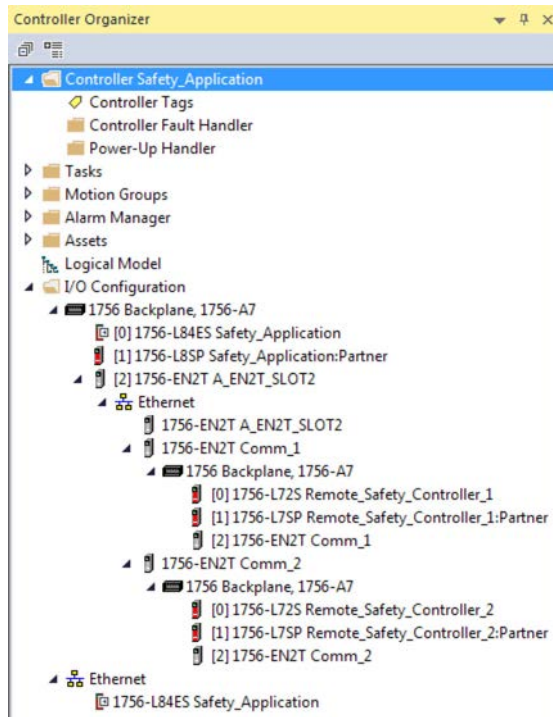

Replace the Producer Controller

If the producer controller has changed to a GuardLogix 5580 SIL 2 application (1-slot solution without a safety partner), while the consumer controller is a GuardLogix 5570 or earlier, the consumer controller can fault due to the missing safety partner in the producer.

The data appears properly, but there is a yellow yield sign (signifying a fault) next to the partner because the partner does not exist. Since there are no single-slot safety controllers available in the Studio 5000 Logix Designer application version 28, you cannot resolve the issue by selecting another controller to represent the single-slot GuardLogix 5580 controller in the SIL 2 application.

Here is the fault for the non-existent partner:

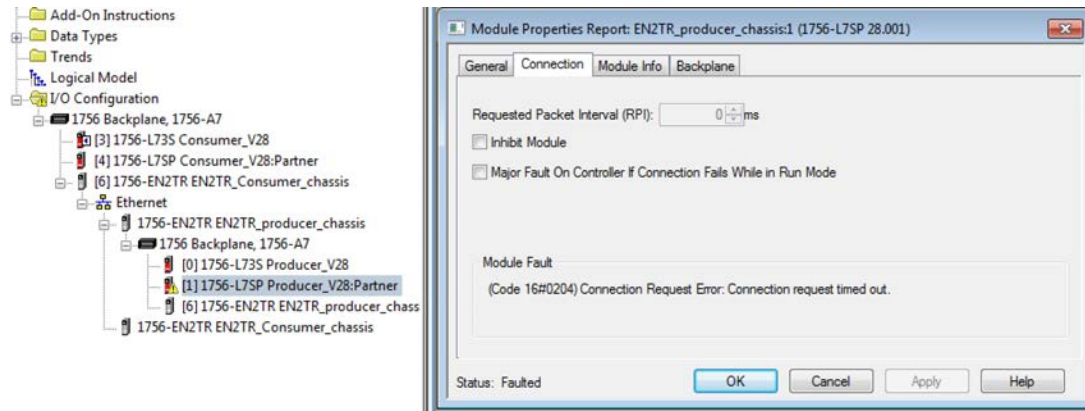

To help eliminate faults:

- In the version 31 producer project, do not place any hardware in the slot to the right of the GuardLogix 5580 SIL 2 controller.
- In the consumer version 28 project, send an SSV to the 1756-L73S to programmatically inhibit the partner module. Place the SSV in the standard routine. The '4' represents bit 2 of the attribute. To un-inhibit the module, set bit 2 back to 0. The partner cannot be inhibited from the I/O tree. The SSV is needed to inhibit the partner only.

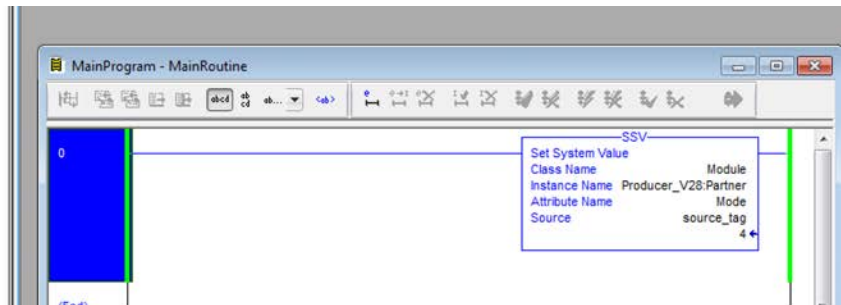
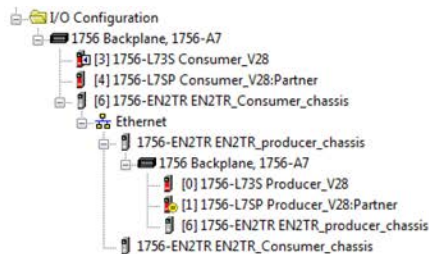

If only standard tags are being produced by the GuardLogix 5580 SIL2 controller, then the existing GuardLogix 5570 controller in the consumer project can be replaced by a ControlLogix 5570 controller. Since the GuardLogix 5570 version 28 controller is consuming standard tags, there is no need for the device in the I/O tree to be a [2-slot] safety controller. Replacing it with any single-slot controller can help eliminate the connection fault.

Notes:

Replacement Considerations with High Availability Systems

Overview

This chapter describes features and functions that are associated with controllers when they are used in high availability systems and the differences in high availability functionality from previous redundant controllers.

You can configure the following types of control systems for high availability:

- Logix SIS (safety instrumented system) - Logix SIS redundancy is designed for safety applications that require high availability. The following support Logix SIS:
 - GuardLogix® 5580 controllers, versions 37.011 and later
 - Safety-enabled 5590 controllers, all versions
- Redundancy - ControlLogix® redundancy is designed for non-safety applications that require high availability. The following support redundancy:
 - ControlLogix 5590 controllers
 - ControlLogix 5580 controllers
 - ControlLogix 5570 controllers

For more information, see:

- High Availability System Reference Manual, publication [HIGHAV-RM002](#)
- ControlLogix Redundancy User Manual, publication [1756-UM015](#)
- ControlLogix 5590 High Availability Systems User Manual, publication [1756-UM901](#)

A high availability system uses a redundant chassis pair to maintain process operation when events occur that stop process operation on non-redundant systems, such as a fault on a controller.

The redundant chassis pair includes two synchronized ControlLogix chassis with specific, identical components in each. For example, one redundancy module and at least one EtherNet/IP™ communication module are required.

Controllers are typically used in redundancy systems, but are not required if your application only requires communication redundancy. Your application operates from a primary chassis, but can switch over to the secondary chassis and components if necessary.

Redundant controllers are required in Logix SIS systems.

Product Comparison Redundancy

This section compares redundancy systems.

	Feature	ControlLogix 5570 Redundancy ⁽¹⁾	ControlLogix 5580 Redundancy	ControlLogix 5590 Redundancy
Chassis Specifications	Up to seven communication modules per chassis	Fully supported	Fully supported ⁽²⁾	Fully supported
	Two controllers per chassis	Fully supported	Not supported	Not supported
	Transparent switchover	Fully supported	Fully supported ⁽²⁾	Fully supported
	Compatible with 1756-RM2 ControlLogix redundancy modules	Fully supported	Fully supported ⁽²⁾	Not supported
	Compatible with 1756-RM3 ControlLogix redundancy modules	Fully supported	Fully supported ⁽²⁾	Fully supported
Process	PhaseManager™ software support	Fully supported	Fully supported ⁽²⁾	Fully supported
	SequenceManager™ software support	Not supported	Partially supported ⁽³⁾	Partially supported ⁽³⁾
	SIL 2 process safety solution with 1715 redundant I/O modules	Fully supported	Not supported	Not supported
	Process controller support with embedded process objects	Not supported	Fully supported ⁽²⁾	Fully supported
Networks	EtherNet/IP™ support	Fully supported	Fully supported ⁽²⁾	Fully supported
	ControlNet® and DeviceNet® support	Fully supported	Not supported ⁽⁴⁾	Not supported ⁽⁴⁾
	Legacy networks and controllers communication: <ul style="list-style-type: none"> Data Highway Plus™ Remote I/O PLC-2®, PLC-5® SLC™ 	Fully supported	Not supported	Not supported
	Support of Gigabit Ethernet	Not supported	Fully supported ⁽²⁾	Fully supported
	Use of the embedded Ethernet port	Not supported	Not supported	Support for Front Port Crossload only
I/O and Devices	5094 FLEX 5000® I/O	Not supported	Fully supported ⁽⁵⁾	Fully supported
	5034 PointMax™ I/O	Not supported	Fully supported ⁽⁶⁾	Fully supported
	5032 ArmorBlock 5000® I/O	Not supported	Fully supported ⁽⁶⁾	Fully supported
	5015 FLEXHA 5000™ I/O	Not supported	Fully supported ⁽⁶⁾	Fully supported
	1756 ControlLogix I/O	Fully supported	Fully supported ⁽²⁾	Fully supported
	1715 Redundant I/O	Fully supported	Fully supported ⁽²⁾	Fully supported
	1794 FLEX™ I/O	Fully supported	Fully supported ⁽²⁾	Fully supported
	1734 POINT I/O™	Fully supported	Fully supported ⁽²⁾	Fully supported
	Drives (non-motion)	Fully supported	Fully supported ⁽²⁾	Fully supported
Security	CIP Security™ support	Not supported	Partially supported ⁽⁷⁾	Partially supported ⁽⁷⁾
	IEC 62443-4-2 SL1 security certification	Not supported	Fully supported ⁽⁸⁾	Not supported
Alarms	Logix instruction-based alarms	Fully supported	Fully supported ⁽²⁾	Fully supported
	Logix-based tag alarms	Not supported	Fully supported ⁽²⁾	Fully supported
Communication	Front Port Crossload mode	Not supported	Not supported	Fully supported

(1) If you use ControlLogix 5570 redundancy for SIL 2 and want to move to Logix SIS redundancy for SIL 2/3, there is no direct migration path. Logix SIS uses different hardware components and programming than ControlLogix 5570 redundancy.

(2) Fully supported with firmware revision 33.011 or later.

(3) Supported with Process controllers only.

(4) DeviceNet modules are supported if accessed across an Ethernet bridge, but can experience a bump during a ControlLogix Redundancy switchover.

(5) Supported with Studio 5000 Logix Designer application projects, version 36 or later.

(6) Supported with Studio 5000 Logix Designer application projects, version 35 or later.

(7) Support for class 3 messaging security only.

(8) Supported in Logix Designer application projects, version 37 or later.

Product Comparison

Logix SIS

This section compares Logix SIS.

	Feature	Logix SIS (GuardLogix 5580 controllers)	Logix SIS (safety-enabled 5590 controllers)
Chassis Specifications	Up to seven communication modules per chassis	Fully supported	Fully supported
	Two controllers per chassis	Not supported	Not supported
	Transparent switchover	Fully supported	Fully supported
	Compatible with 1756-RM2 ControlLogix redundancy modules	Fully supported	Not supported
	Compatible with 1756-RM3 ControlLogix redundancy modules	Fully supported	Fully supported
Process	PhaseManager™ software support	Fully supported	Fully supported
	SequenceManager software support	Not supported	Partially supported ⁽¹⁾
	SIL 2 process safety solution with 1715 redundant I/O modules	Not supported	Not supported
	Process controller support with embedded process objects	Not supported	Partially supported ⁽¹⁾
Networks	EtherNet/IP support	Fully supported	Fully supported
	ControlNet and DeviceNet support	Not supported ⁽²⁾	Not supported ⁽²⁾
	Legacy networks and controllers communication: <ul style="list-style-type: none"> • Data Highway Plus • Remote I/O • PLC-2, PLC-5 • SLC 	Not supported	Not supported
	Support of Gigabit Ethernet	Fully supported	Fully supported
	Use of the embedded Ethernet port	Not supported	Support for Front Port Crossload only
I/O and Devices	5094 FLEX 5000 safety I/O	Fully supported	Fully supported
	5094 FLEX 5000 I/O	Fully supported	Fully supported
	5034 PointMax	Fully supported	Fully supported
	5032 ArmorBlock 5000 I/O	Fully supported	Fully supported
	5015 FLEXHA 5000 I/O	Fully supported	Fully supported
	1756 ControlLogix I/O	Fully supported	Fully supported
	1715 Redundant I/O	Fully supported	Fully supported
	1794 FLEX I/O	Fully supported	Fully supported
	1734 POINT I/O™	Fully supported	Fully supported
Drives (non-motion)	Fully supported	Fully supported	
Security	CIP Security support	Partially supported ⁽³⁾	Partially supported ⁽³⁾
	IEC 62443-4-2 SL1 security certification	Fully supported	Not supported
Alarms	Logix instruction-based alarms	Fully supported	Fully supported
	Logix-based tag alarms	Fully supported	Fully supported
Communication	Front Port Crossload mode	Not supported	Fully supported

(1) Supported with Process controllers only.

(2) DeviceNet modules are supported if accessed across an Ethernet bridge, but can experience a bump during a ControlLogix Redundancy switchover.

(3) Support for class 3 messaging security only.

Front Port Crossload

ControlLogix 5590 controllers support Front Port Crossload mode. It is a communication mode that improves scan time performance by crossloading task data through the front Ethernet ports on the controller. Scan time decreases by 2x when data is crossloaded through the front ports compared to the backplane.

Data Transfer

ControlLogix 5590, ControlLogix 5580, and GuardLogix 5580 controllers use 4K byte pages for data transfer, while ControlLogix 5570 controllers use 256-byte grains for data transfer.

This table shows how much data is transferred from the primary controller to the secondary controller, assuming each tag is a DINT.

Scenario	ControlLogix 5570 transfer size range (bytes)	ControlLogix 5580 transfer size range (bytes)	ControlLogix 5590 transfer size range (bytes)
Change 1 tag	256	4096	4096
Change 2 adjacent tags	256	4096	4096
Change 2 non-adjacent tags	256...512	4,096...8,192	4,096...8,192
Change 10 adjacent tags	256...512	4,096...8,192	4,096...8,192
Change 10 non-adjacent tags	256...2,560	4,096...40,960	4,096...40,960
Change 16 non-adjacent tags	256...4,096	4,096...65,536	4,096...65,536
Change 1000 tags	4,096...256,000	4,096...4,096,000	4,096...4,096,000

IMPORTANT

We recommend keeping data that changes at similar frequencies adjacent to minimize impacts on crossloading. For this and additional information, see the following:

- ControlLogix Redundancy User Manual, publication [1756-UM015](#)
- ControlLogix 5590 High Availability Systems User Manual, publication [1756-UM901](#)
- High Availability System Reference Manual, publication [HIGHAV-RM002](#)

Standard Application Conversion

This chapter describes application conversions for the controllers. This chapter features these controllers, and where applicable, the controllers are known as:

Controller Family	Includes these controllers
5590 controllers	ControlLogix® 5590 controllers
5580 controllers	ControlLogix 5580 and GuardLogix® 5580 controllers
5380 controllers	CompactLogix® 5380, Compact GuardLogix 5380 SIL 2, and Compact GuardLogix 5380 SIL 3 controllers
5570 controllers	ControlLogix 5570 and GuardLogix 5570 controllers
5370 controllers	CompactLogix 5370 and Compact GuardLogix 5370 controllers

Converting Logix Designer Projects

When you open a Studio 5000 Logix Designer® project to open a project that was created in an earlier version of Logix Designer application, the project is converted to the higher version. After the conversion, the Logix Designer application can fail to use internal memory structures in the most efficient manner.

To help optimize the internal memory structures, you can complete the following:

- Import the version 27 or earlier project from an ASCII.L5K or an XML .L5K file to create the version 28 or later project.
- Import rungs, routines, programs, equipment phases, UDTs, tags, and Add-On Instructions into a version 28 or later project.

For information on how to import your project, see:

- Logix 5000® Controllers Import/Export Reference Manual, publication [1756-RM084](#).
- Logix 5000 Controllers Import/Export Project Components Programming Manual, publication [1756-PM019](#).

Produce and Consume Tags

The recommendations in this section provide techniques for establishing produced or consumed tag communication between the following:

- 5590, 5580 and 5570 controllers
- 5380 and 5370 controllers

RPI of Multicast Tags

In version 27 or earlier projects, a produced tag produces data at the RPI of the fastest requesting consumer. This lets multiple consumers with different RPIs successfully connect to a producer.

In version 28 or later projects, the first consumer of a produce tag determines the RPI rate at which data is produced. All subsequent consumers must request the same RPI value as the first consumer. Otherwise, the subsequent consumers fail to connect.

When you migrate a Logix Designer project, version 27 or earlier, to a later version of the application, verify that the multicast consumers of a produce tag are configured properly in the original project. [Table 11](#) provides more information.

Table 11 - Proper Configuration of Multicast Consumers of a Produced Tag

Consuming Controller	Producing Controller	Description
Any controller, version 17 or earlier		Verify that all multicast consumed tags of a produced tag are configured with the same RPI. If they are not, some of the consumers can fail to connect.
Any controller, version 18 or later	ControlLogix 5580 controller, version 28 or later	Verify that one of the following exists: <ul style="list-style-type: none"> • All multicast consumers of a produced tag are configured with the same RPI. • All consumers are configured to Allow Consumed Tags To Use RPI Provided By Producer.
Any controller, version 20 or later	CompactLogix 5380 controller, version 28 or later	Verify that one of the following exists: <ul style="list-style-type: none"> • All multicast consumers of a produced tag are configured with the same RPI. • All consumers are configured to Allow Consumed Tags To Use RPI Provided By Producer.

Data Structures

The Logix Designer application has requirements for data type use. The requirements differ based on the Logix Designer application version that you use.

Logix Designer Application Version	Requirement
Version 26 or earlier	Logix 5000 controllers require all data types to be placed on 4-byte address boundaries in RAM.
Version 27 or later	Logix 5000 controllers require 8-byte (64-bit) data types (LINTs) to be placed on 8-byte address boundaries in RAM.

The Logix Designer application manages the requirement automatically, and the change has no effect on individual LINT tags, regardless of application version.

The requirement change between Logix Designer application, version 26, and version 27 is fundamental to the application and applies to all Logix 5000 controllers. The fact that the requirement was changed does not alone require action on your part.

Conditions can exist within which the change between Logix Designer application, versions 26, and version 27 contributes to the need for action on your part.

If you migrate a Logix Designer project, version 26 or earlier, to a Logix Designer project, version 27 or later, LINTs inside a UDT can be misaligned. Additional pad bytes are added to the data structure to account for the misalignment. The pad bytes can cause an increase in the size of the UDT.

The possible effects of data structure changes, and subsequent actions that you can take as a result, are described in the rest of this section.

IMPORTANT You must act when in the following conditions:

- You migrate a project, version 26 or earlier, to project, version 27 or later, and you have LINT tags inside a UDT.
- Your application includes Logix 5000 controllers, version 26 or earlier, that communicate with Logix 5000 controllers, version 27 or later.

Possible Impact of Requirement Change

You can adapt your project to accommodate larger structure sizes, if necessary. You can see the following effects due to the larger size:

- Message instruction data lengths can require changes to complete successfully.
- Copy lengths of data structures can change.
- Produce/Consume connections to other Logix controller types can have data type mismatches and require changes to complete successfully.

To correct Produce/Consume errors that are caused by UDT alignment changes, modify the tag structures in both projects so that they match.

- Produce/Consume with Status requires an exact match of the UDT definition (including the name of the UDT definition).
- Produce/Consume without Status requires the Size of the UDT to match.

We recommend that you copy and paste the UDT definition from one project to the other to cover both of these cases. Use the Data Type editor to check the Data Type Size in both projects:

Figure 28 - Data Type Editor

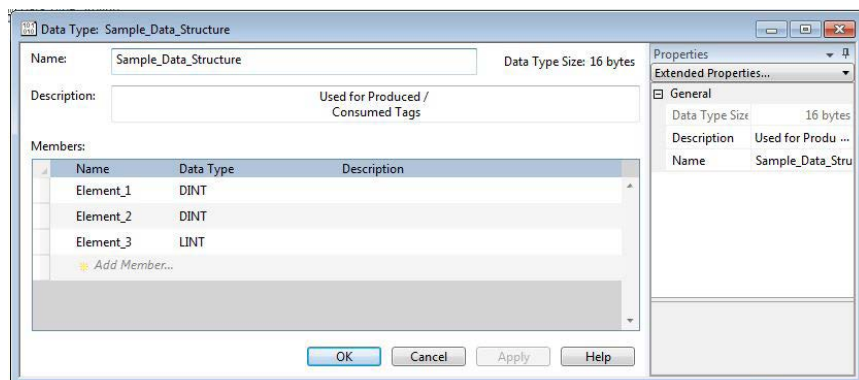

If the data type size is different between the two projects, modify the UDT to produce the same internal data structure.

The following sample UDT illustrates how the 8-byte allocation rule and the 8-byte alignment rule cause a UDT to have another size.

Figure 29 - UDT Sample - Needs Additional Memory Allocation and Alignment

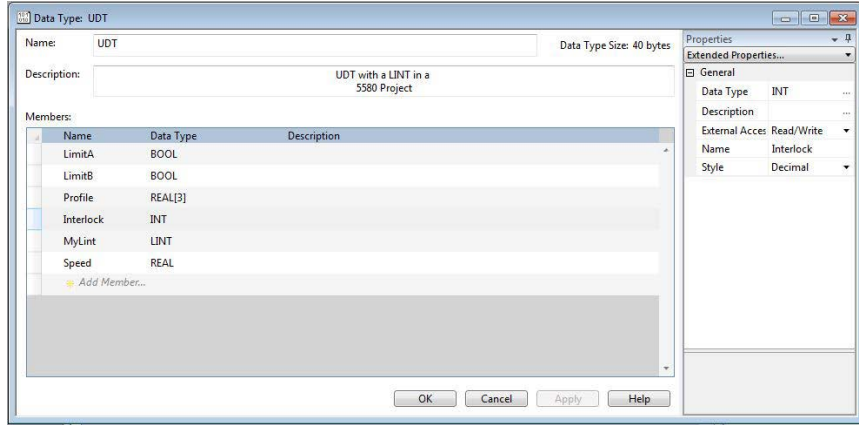

Table 12 illustrates how this data structure maps in a Logix Designer project, version 26 or earlier. MyLint is split across two 64-bit words, and the total size is only 32 bytes.

Table 12 - Data Structure for Logix Designer Projects, Version 26 or Earlier

Word	Elements	Byte Mapping Table				64-Bit Boundaries
0	LimitA and LimitB	Pad	Pad	Pad	Hidden SINT	0
1	Profile (Real [3])	Map	Map	Map	Map	
2		Map	Map	Map	Map	1
3		Map	Map	Map	Map	
4	Interlock (Int)	Pad	Pad	Map	Map	2
5	MyLint (LINT)	Map	Map	Map	Map	
6		Map	Map	Map	Map	
7	Speed (REAL)	Map	Map	Map	Map	3

Table 13 illustrates the hidden padding bytes that the Logix Designer application automatically adds to achieve the 8-byte alignment and allocation rules for a Logix Designer project, version 27 or later.

Consider the following:

- Padding is added in Word 5 so that MyLint starts at an 8-byte boundary.
- Padding is added in Word 9 so that the entire structure is a multiple of 8 bytes.

Table 13 - Hidden Padding Added for Logix Designer Projects, Version 27 or Later

Word	Elements	Byte Mapping Table				64-Bit Boundaries
0	LimitA and LimitB	Pad	Pad	Pad	Hidden SINT	0
1	Profile (Real [3])	Map	Map	Map	Map	
2		Map	Map	Map	Map	1
3		Map	Map	Map	Map	
4	Interlock (Int)	Pad	Pad	Map	Map	2
5	Padding for 8-byte alignment	Pad	Pad	Pad	Pad	
6	MyLint (LINT)	Map	Map	Map	Map	3
7		Map	Map	Map	Map	
8	Speed (REAL)	Map	Map	Map	Map	4
9	Padding for 8-byte allocation	Pad	Pad	Pad	Pad	

To create a UDT that is the same size in all types of projects, insert additional data elements so that hidden padding bytes are not necessary.

The following sample UDT illustrates how UnusedDint1 and UnusedDint2 were added to create a UDT with the same size in a Logix Designer project, version 26 or earlier compared to a Logix Designer project, version 27 or later.

Figure 30 - UDT Sample - Memory Allocation and Alignment OK

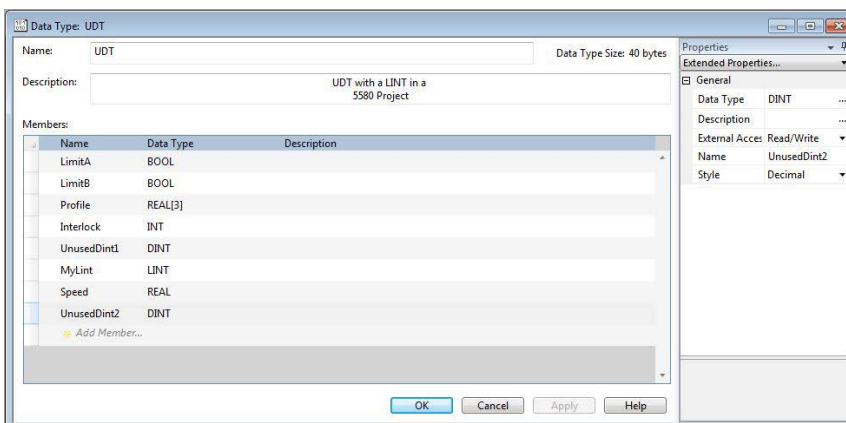

[Table 14](#) illustrates how this data structure maps in all types of Logix 5000 controller projects:

Table 14 - Memory Map in All Project Types

Word	Elements	Byte Mapping Table				64-Bit Boundaries
0	Bools and 2	Pad	Pad	Pad	Hidden SINT	0
1	Profile (Real [3])	Map	Map	Map	Map	
2		Map	Map	Map	Map	1
3		Map	Map	Map	Map	
4	Interlock (Int)	Pad	Pad	Map	Map	2
5	UnusedDint1	Map	Map	Map	Map	
6	MyLint (LINT)	Map	Map	Map	Map	3
7		Map	Map	Map	Map	
8	Speed (REAL)	Map	Map	Map	Map	4
9	UnusedDint2	Map	Map	Map	Map	

The concept is the same for nested UDTs. If the lower-level UDT is an 8-byte type (that is, it contains at least one 8-byte data element), you must align it to start at an 8-byte boundary.

To correct any mismatched UDTs, complete the following tasks in either project:

1. Start at the deepest nesting level of any multi-level UDT.
2. Work from the beginning of each structure and look for LINT data types.
3. For each LINT data type or 8-byte UDT encountered, map out the sizes of the prior UDT elements, to determine the byte offset at the start of the element.

For more information, see [Instruction Error and Fault Changes on page 160](#).

If the byte offset for the first 8-byte element is not divisible by 8 bytes (64 bits), insert a DINT tag element just above the 8-byte element. You can use any name. Instructions do not need to reference this element.

4. Repeat the process until all 8-byte elements are aligned on 8-byte (64-bit) boundaries.
5. If needed, add a DINT at the end of the UDT to satisfy the 8-byte allocation rule.
6. Continue up through nested UDTs until the top level is correct.

When the tasks are completed, the UDTs are the same size in the Logix Designer project, version 26 or earlier and the Logix Designer project, version 27 or later.

You can use the padded UDTs in the Logix Designer project, version 26 or earlier and the Logix Designer project, version 27 or later.

A useful technique when creating UDTs is to start with the largest data types first, and work down through 8-byte, 4-byte, 2-byte, 1-byte, and finally single-bit data types. The resultant mapping is 64-bit-aligned in all controller types, so no manual padding is required.

Produce/Consume with Status and Safety Produce/Consume tags require an adjustment to this technique. For these cases, the UDT must start with a 4-byte 'COMMAND_STATUS' element; therefore, one more 4-byte element (DINT or REAL) must be added before placing any 8-byte elements.

Late Binding of I/O Data

The Compact 5000® I/O module family is the first set of Allen-Bradley® I/O modules use the following:

- A high-speed backplane that is optimized for performance that significantly exceeds previous I/O module families.
- A standard design for I/O tags based on module type that can be replicated in the development of other I/O modules.

The standard design can simplify how you use modules from different I/O module families in a Studio 5000 Logix Designer application project.

Standard Native I/O Data Types and Tags

When you add I/O modules to a Logix Designer application project, the application automatically creates native I/O data types and tags. Historically, the native I/O data types and tags differed between I/O module families because the module designs differed.

With the introduction of the standard design by module type, the Logix Designer application creates standard native I/O data types and tags for modules of the same type irrespective of their families. Standard native I/O data types and tags make possible the concept of “late binding” of I/O data in Logix 5000 controllers.

You can write programs, routines, and Add-On instructions that operate on a set of standard I/O tags. The programs, routines, and Add-On instructions can then be applied, regardless of the I/O module family that is connected to the controller, early in the design phase and at any point in the implementation process, and use the same syntax.

The standard I/O data types and tags remove the task of changing or updating programming code modules based on the specific I/O module family that is used. As more I/O modules that use the standard design are developed, the use of multiple I/O module platforms in a Logix Designer gets progressively easier.

I/O Data Manipulation

When you address Compact 5000® I/O modules in a Logix Designer application project, many instructions that previously permitted a direct reference to an entire input or output word now report an invalid data type error.

You can encounter the invalid data type error when you migrate programs that are written for older Logix 5000 controllers and I/O platforms to programs written for 5580 and 5380 controllers with Compact 5000 I/O modules. The error is the result of the new structure that was implemented with the Compact 5000 I/O platform, as described in the previous section. The I/O data is grouped by “channel” by default, and no longer shown at the word level as an INT or DINT data type.

To get around this error a “Packed Data” type can be selected at the I/O configuration screen when adding the I/O module in the Logix Designer application. You can use a Copy File (COP) instruction or Synchronous Copy File (CPS) instruction to move the packed data into an interim tag. You can then use the tag in the user program for word-level manipulation.

We recommend that you only use CPS instructions when you need data integrity with copying produce/consume tag and I/O tag data. Overuse of the CPS instruction can have unintended consequences on task execution and program scan time.

When encountered with this error in converting your programs, follow closely the guidelines in Knowledgebase Article [Invalid data type error when using 5069 I/O modules](#) for a suitable migration path forward.

Controller Memory Usage

Data usage is indicated with one value that combines Data and Logic memory usage and I/O memory usage. As you change the project, the data values are automatically updated to indicate the estimated memory usage and remaining available memory.

The available memory-used attributes are not supported with ControlLogix 5590, ControlLogix 5580, CompactLogix 5380, and CompactLogix 5480 controllers, as these controllers use memory differently and contain a new updated memory architecture.

You can no longer programmatically monitor a controllers' available memory via a MSG instruction, as the controller's memory no longer changes after a project is downloaded. To verify available controller memory, view the Controller Properties Memory Tab in the Logix Designer application.

For more information on controller memory, see:

- ControlLogix 5580 controller Memory Tab on [page 38](#).
- CompactLogix 5380 controller Memory Tab on [page 99](#).
- Logix 5000 Controllers Design Considerations Reference Manual, publication [1756-RM094](#).

Unconnected Message Buffers

5580 and 5380 controllers have 320 unconnected message buffers to support any combination of outgoing or incoming unconnected messages.

5590 controllers have 448 unconnected message buffers to support any combination of outgoing or incoming unconnected messages.

These controllers no longer support the ability to use a CIP Generic message to increase or decrease the number of unconnected message buffers. When migrating to a 5590, 5580, or 5380 controller, you should remove any code that changes the number of unconnected buffers.

Motion Applications

The use of integrated motion is slightly different between controllers. For example, not all CompactLogix 5380 and Compact GuardLogix 5380 controllers support Integrated Motion over an EtherNet/IP™ network.

ControlLogix 5590, ControlLogix 5580, and GuardLogix 5580 Controllers

5590 controllers support up to 512 axes, and 5580 controllers support up to 256 axes of integrated motion.

The number of axes that a controller supports is based on the Ethernet node limit for the specific controller. The axes can be any combination of the following axis types:

- CIP™
- Virtual
- Consumed

You can add all axes to one Motion Group, and you can assign any combination of axes to different axis update schedules.



We recommend that you use the built-in EtherNet/IP port for high-performance motion applications.

Table 15 - Available Motion Networks for ControlLogix Controllers

Motion Networks	5590 Controllers	5580 Controllers	5570 Controllers
EtherNet/IP	Yes	Yes	Yes
Analog Motion	Yes	Yes ⁽¹⁾	Yes
SERCOS	Yes	Yes ⁽¹⁾	Yes

(1) With Studio 5000 Logix Designer application, version 31 or later.

You can associate Integrated Motion axes with any appropriate drive. You can make the association regardless of whether the communication path to the drive is via the embedded Ethernet port, or over the 1756 backplane through an Ethernet bridge.

Table 16 - New Axis Menu

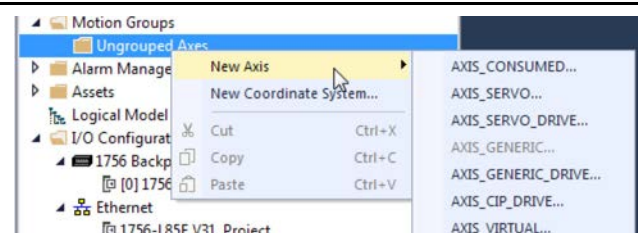
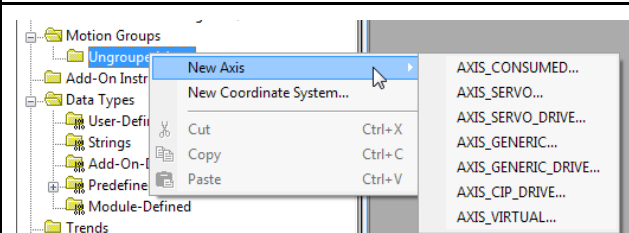
5590 Controllers and 5580 Controllers	5570 Controllers
	

For more information on axis limits and scheduling, see the Integrated Motion on the EtherNet/IP Network User Manual, publication [MOTION-UM003](#).

CompactLogix 5380 and Compact GuardLogix 5380 Controllers

Some CompactLogix 5380 and Compact GuardLogix 5380 controllers support integrated motion. For information on the controllers that support motion, see the CompactLogix 5380 and Compact GuardLogix 5380 Controllers User Manual, publication [5069-UM001](#).

The controllers support up to 32 axes of integrated motion. The 32 axes can be any combination of the following axis types:

- CIP - Up to 32 Position Loop axes are supported
- Virtual Axes

The number of total axes that a controller supports is based on the Ethernet node limit for the specific controller. These axes types include velocity loop, torque loop, feedback only, frequency control, and others.

You can add all axes to one Motion Group, and you can assign any combination of axes to different axis update schedules.

The 5380 and 5370 controllers only support integrated motion on an EtherNet/IP network.

For information on motion axes and Integrated Motion on an EtherNet/IP network, see the Integrated Motion on the EtherNet/IP Network: Configuration and Startup User Manual, publication [MOTION-UM003](#).

You can associate Integrated Motion axes to any appropriate drive. The Axis menu is the same for the 5380 and 5370 controllers:

Figure 31 - Axis Menu

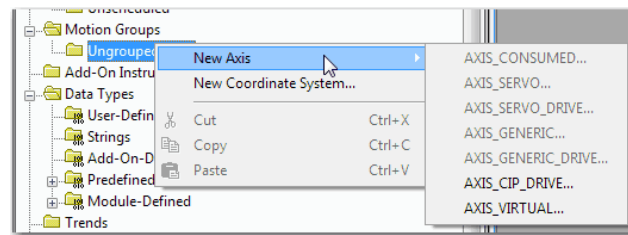

Axis Position References in Move Instructions

When you use Feedback Only or Torque Loop Configured axes in the following Motion instructions, the available position data updates are different based on the Logix Designer projects within which they are used:

- Motion Axis Gear (MAG)
- Motion Arm Output Cam (MAOC)
- Motion Axis Position Cam (MAPC)
- Master Driven Speed Control (MDSC)

If you use a Logix Designer project, version 25 or earlier, the Motion Planner provides Actual Position and Command Position data updates.

If you use a Logix Designer project, version 26 or later, the Motion Planner provides only Actual Position data updates.

If you migrate a Logix Designer project, version 25 or earlier, to a Logix Designer project, version 26 or later, update your project where necessary to use the Actual Position data reference and not the Command Position data reference.

Pending Edits

Online edits now help you avoid unintentionally leaving routines in an inconsistent state. Accept Pending Edits is now blocked if any pending edits have verification errors.

Language	Affected
Ladder Logic (RLL)	Yes
Structured Text (ST)	Yes
Function Blocks (FBD)	Yes
Sequential Function Chart (SFC)	Yes

This implementation affects all instructions in the instruction set.

5590/5580/5380 Controllers	5570/5370 Controllers
If you edit multiple rungs and choose Accept Pending Edits, Logix Designer does the following. <ul style="list-style-type: none"> • Accepts all rungs if there are no verification errors. • Accepts none of the rungs if errors occur. 	You can accept and download individual Pending Edits to controller, while edits that error out are not downloaded to the controller.

IMPORTANT Manually determine the impact to your application and correct accordingly.

AXIS_CIP_Drive Data Type

Starting with the Studio 5000 Logix Designer application version 31, some Axis Safety Fault tags in the AXIS_CIP_DRIVE data type are renamed. See [Table 17](#).

Table 17 - Axis Safety Fault Tags

Pre-version 31 Tag	Version 31 or Later Tag
SafeStop1Fault	SS1Fault
SafeStop2Fault	SS2Fault
SafeOperatingStopFault	SOSFault
SafeBrakeFault	SBCFault
SafeMotorOverttemperatureFault	SMTFault
SafeSpeedMonitorFault	SSMFault
SafeLimitedSpeedFault	SLSFault
SafeLimitedAccelFault	SLAFault
SafeLimitedDirectionFault	SDIFault

When you convert to a version 31 or later project, the updates are applied automatically.

If you import a pre-version 31 program or routine that uses these tag names, your project can experience errors.

Notes:

Instruction Execution

This chapter features these controllers, and where applicable, the controllers are known as:

Controller Family	Includes these controllers
5590 controllers	ControlLogix® 5590 controllers
5580 controllers	ControlLogix® 5580 and GuardLogix® 5580 controllers
5380 controllers	CompactLogix® 5380, Compact GuardLogix 5380 SIL 2, and Compact GuardLogix 5380 SIL 3 controllers
5570 controllers	ControlLogix 5570 and GuardLogix 5570 controllers
5370 controllers	CompactLogix 5370 and Compact GuardLogix 5370 controllers

This chapter describes the changes in instructions, and the comparisons between the 5590/5580/5380 controllers and the 5570/5370 controllers.

Math-related Instructions

This section describes the changes in math-related instructions and apply to the following:

- [TRN Instruction Changes](#)
- [Improved Math Instruction Accuracy](#)
- [SOR/SORT Adjustment](#)
- [X Mod 0](#)
- [AND, NOT, OR, and XOR Support for REAL](#)
- [Floating Point Literals](#)
- [XPY Instruction](#)
- [0.0 div 0.0](#)

IMPORTANT Manually determine the impact to your application and correct accordingly.

TRN Instruction Changes

Language	Affected
Ladder Logic (RLL)	Yes
Structured Text (ST)	Yes
Function Blocks (FBD)	No
Sequential Function Chart (SFC)	Yes ⁽¹⁾

(1) Only affects embedded Structured Text.

Previously, if a large real number was truncated, overflow of the internal math that the instructions performs was possible. As a result, the instruction returned a zero. Some large reals that failed and returned a zero when truncated now return a value.

In RLL, S:V is set properly when the value that is truncated is too large to be stored in the destination. With this implementation, the truncation of real values to real destinations is more likely to complete without errors.

5590/5580/5380 Controllers	5570/5370 Controllers

Mitigation

Modify any existing code that relied on obtaining a zero result instead of range-checking the input value.

Improved Math Instruction Accuracy

Language	Affected
Ladder Logic (RLL)	Yes
Structured Text (ST)	Yes
Function Blocks (FBD)	Yes
Sequential Function Chart (SFC)	Yes ⁽¹⁾

(1) Only affects embedded Structured Text.

The implementation changed from a proprietary implementation of a commonly found polynomial algorithm to invoking a function in a standard, commercial off-the-shelf, C math library. The algorithm change, along with hardware improvements, help to improve overall accuracy for the controllers.

This implementation affects these instructions: ACS/ACOS, ASN/ASIN, ATN/ATAN, COS, LN, LOG, SIN, SQR, TAN, XPY.

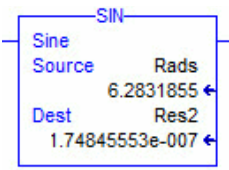
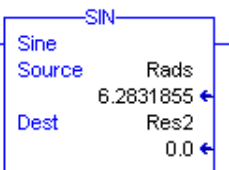
5590/5580/5380 Controllers	5570/5370 Controllers
 <p>Because 2*PI is an estimated value for Rads, the result does not equal 0.0.</p>	

Reverify any existing code that expects an exact result whenever the input is close to values that produce zero, infinity, or asymptotic results.

SQR/SQRT Adjustment

Language	Affected
Ladder Logic (RLL)	Yes
Structured Text (ST)	Yes
Function Blocks (FBD)	Yes
Sequential Function Chart (SFC)	Yes

The SQR/SQRT instruction now uses round-to-even type conversion of the floating point result to integer destination. Previously, this operation truncated the floating point result.

The new implementation results in behavior from the SQR instruction that better matches the IEC standard math expectations.

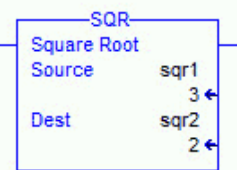
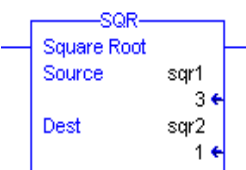
5590/5580/5380 Controllers	5570/5370 Controllers
 <p>Source - DINT Dest - DINT</p>	 <p>Source - DINT Dest - DINT</p>

Mitigation

N/A

X Mod 0

Language	Affected
Ladder Logic (RLL)	Yes
Structured Text (ST)	Yes
Function Blocks (FBD)	Yes
Sequential Function Chart (SFC)	No

This instruction was updated to conform to IEC 61131-3 ed. 2 table 28 for MOD function. In this case, anything Mod 0 results in 0.

This implementation affects the MOD instruction.

5590/5580/5380 Controllers	5570/5370 Controllers

Mitigation

N/A

AND, NOT, OR, and XOR Support for REAL

Language	Affected
Ladder Logic (RLL)	Yes
Structured Text (ST)	Yes
Function Blocks (FBD)	No
Sequential Function Chart (SFC)	No

The verification rules for these instructions now let you use REAL operands in RLL routines that are based on existing behavior in non-RLL languages.

This implementation helps to make programming for these instructions consistent across all languages.

5590/5580/5380 Controllers

Also supported in RLL.

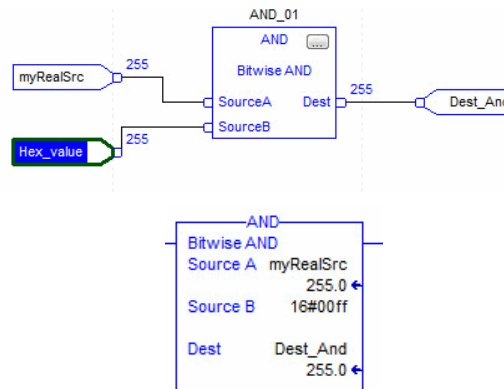

5590/5570/5370 Controllers

Bitwise arithmetic operations for reals only in FBD.

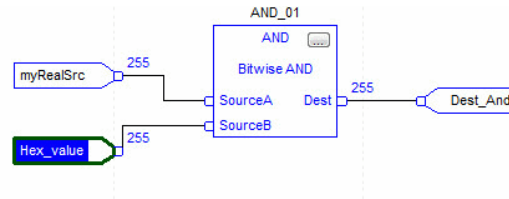

When used in RLL, you get this error: Invalid Data Type. Argument must match parameter data type.

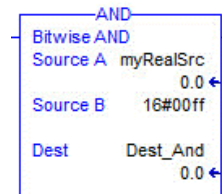

```
Error: Rung 4, AND, Operand 0: Invalid data type. Argument must match parameter data type.
Error: Rung 4, AND, Operand 2: Invalid data type. Argument must match parameter data type.
```

Mitigation

N/A

XPY Instruction

Language	Affected
Ladder Logic (RLL)	Yes
Structured Text (ST)	Yes
Function Blocks (FBD)	Yes
Sequential Function Chart (SFC)	Yes ⁽¹⁾

(1) Only affects embedded Structured Text.

This implementation matches the industry standard behavior for raising X to the power of Y.

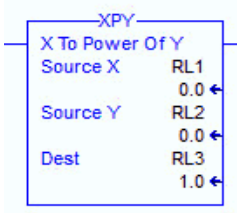
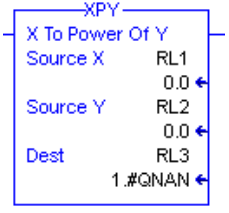
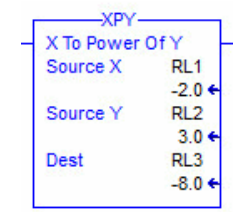
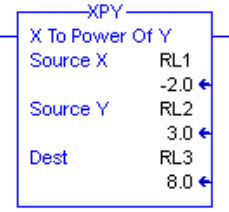
5590/5580/5380 Controllers	5570/5370 Controllers
	
	

Mitigation

N/A

0.0 div 0.0

Language	Affected
Ladder Logic (RLL)	Yes
Structured Text (ST)	Yes
Function Blocks (FBD)	Yes
Sequential Function Chart (SFC)	Yes ⁽¹⁾

(1) Only affects embedded Structured Text.

The special case of a floating point divide of zero by zero now results in a NAN value. Legacy controllers produced infinity.

This implementation affects the DIV instruction.

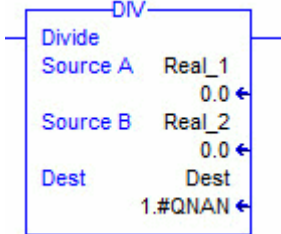
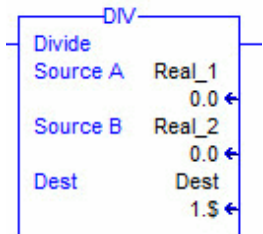
5590/5580/5380 Controllers	5570/5370 Controllers
<p>DIV(0.0, 0.0, dest) now produces NAN.</p> 	<p>DIV(0.0, 0.0, dest) used to produce infinity.</p> 

Mitigation

Inspect your applications for the Divide operation and correct accordingly.

Structural Changes to Execution

This section describes the structural changes to execution, and apply to the following:

- [JSR Nesting Level Limit](#)
- [Max Number of Inputs or Outputs for a Program JSR/RET](#)
- [Max Number of InOut Parameters for an Add-On Instruction](#)
- [Jump to Label Must Be Present](#)
- [MCR Placement](#)
- [Data Alignment and Memory Allocation Rules for User-defined Data Types \(UDTs\) That Contain LINTs](#)
- [SFC Reset Affect on Active Step](#)

IMPORTANT Manually determine the impact to your application and correct accordingly.

JSR Nesting Level Limit

Language	Affected
Ladder Logic (RLL)	Yes
Structured Text (ST)	Yes
Function Blocks (FBD)	Yes
Sequential Function Chart (SFC)	Yes ⁽¹⁾

(1) Only affects embedded Structured Text.

When you nest routines, the controller reserves enough memory to execute to a maximum of 25 nesting levels. Previously, controllers let you continue to nest until they ran out of stack space and faulted.

The major fault 'Nesting limits exceeded' signifies that you have exceeded the nesting limit.

This implementation affects the JSR instruction.

5590/5580/5380 Controllers	5570/5370 Controllers
<p>1 major fault since last cleared.</p> <p>Recent Faults:</p> <pre>1/19/2015 5:56:57 PM (Type 04) Program Fault (Code 94) Nesting limits exceeded. Task: MainTask Program: MainProgram Routine: structural_changes Location: Rung 4</pre>	<p>1 major fault since last cleared.</p> <p>Recent Faults:</p> <pre>1/4/1998 3:19:48 AM (Type 04) Program Fault (can be trapped by a fault routine) (Code 84) Stack overflow. Stack too small to perform operation. Task: MainTask Program: MainProgram Routine: structural_changes Location: Rung 4</pre>

Mitigation

Restructure your project to avoid excessive subroutine nesting. Resolve any verification errors that occur when you open and import projects in the Logix Designer application, version 28 or later.

Max Number of Inputs or Outputs for a Program JSR/RET

Language	Affected
Ladder Logic (RLL)	Yes
Structured Text (ST)	Yes
Function Blocks (FBD)	Yes
Sequential Function Chart (SFC)	Yes ⁽¹⁾

(1) Only affects embedded Structured Text.

JSR calls are now limited to 40 input parameters and 40 output parameters. With this limit, the controller is less likely to run out of memory at runtime. If you exceed this limit, you get a verification error.

Previously, there was no limit on the number of parameters you could define as an input or output parameter. The absence of a limit can cause the controller to run out of stack space at runtime and fault.

This implementation affects these instructions: JSR, RET, SBR.

5590/5580/5380 Controllers	5570/5370 Controllers
<p>Error: 6, JSR: Too many operands specified.</p>	

Mitigation

Resolve any verification errors that occur when you open and import projects in the Logix Designer application, version 28 or later.

Max Number of InOut Parameters for an Add-On Instruction

When an Add-On Instruction is called, the number of InOut parameters that you can pass into or out of the Add-On Instruction is as follows:

- Logix Designer application, version 28 or earlier - 40
- Logix Designer application, version 29 or later - 64

If you exceed the limits indicated, verification error occurs. There is no imposed limit on inputs or output parameters. You cannot access the limits inside an Add-On Instruction.

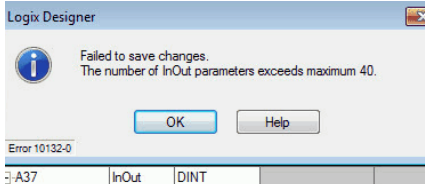
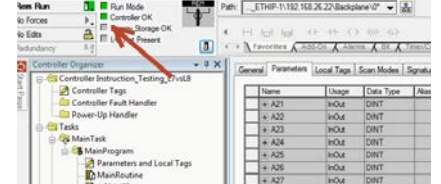
5590/5580/5380 Controllers	5570/5370 Controllers
	

Mitigation

Resolve any verification errors that occur when you open and import projects in the Logix Designer application, version 28 or later.

Add-On Instruction Nesting Level Limit

When you nest Add-On Instructions, the number of levels to which you are limited is as follows:

- Logix Designer application, version 28 or earlier - 25
- Logix Designer application, version 29 or later - 16

The controller has reserved enough memory to execute to the nesting level specified above. You cannot access the limits inside an Add-On Instruction. The major fault 'Nesting limits exceeded' signifies that you have exceeded the nesting limit.

5590/5580/5380 Controllers	5570/5370 Controllers
When you nest Add-On Instructions, the number of levels to which you are limited is as follows: <ul style="list-style-type: none"> • Logix Designer application, version 28 or earlier - 25 • Logix Designer application, version 29 or later - 16 	Previously, controllers let you continue to nest until they ran out of stack space and faulted.

Mitigation

Resolve any verification errors that occur when you open and import projects in the Logix Designer application, version 28 or later.

Jump to Label Must Be Present

Language	Affected
Ladder Logic (RLL)	Yes
Structured Text (ST)	No
Function Blocks (FBD)	No
Sequential Function Chart (SFC)	No

Previously, a jump to label request could reference a label that did not exist and cause a fault. The 5580 and 5380 controllers require the label to exist before the following:

- You download the project to the controller if you are working offline.
- You accept edits if you are working online.

Project verification now detects missing LBLs to help lower the risk of unexpected runtime faults.

```
Verifying routine 'MainRoutine' of program 'MainProgram'
Error: Rung 1, JMP: JMP instruction has no target label (Label_1).
```

This implementation affects these instructions: JMP, LBL.

5590/5580/5380 Controllers	5570/5370 Controllers
<p>The controllers now require the label to exist before:</p> <ul style="list-style-type: none"> • Downloading if working offline. • Accepting edits if working online. 	<p>Missing LBLs are not detected until the corresponding JMPs are executed. Depending on input logic, the project can appear to run OK until conditions trigger a JMP to a missing target.</p> <div style="border: 1px solid #ccc; padding: 5px; margin-top: 10px;"> <p>1 major fault since last cleared.</p> <p>Recent Faults:</p> <p>1/4/1998 3:32:57 AM (Type 04) Program Fault (can be trapped by a fault routine) (Code 42) JMP to a label that did not exist or was deleted. Task: MainTask Program: MainProgram Routine: structural_changes Location: Rung 0</p> </div>

Mitigation

Resolve any verification errors that occur when you open and import projects in the Logix Designer application, version 28 or later.

MCR Placement

Language	Affected
Ladder Logic (RLL)	Yes
Structured Text (ST)	No
Function Blocks (FBD)	No
Sequential Function Chart (SFC)	No

The MCR instruction must be the last instruction on any rung. Otherwise, the project generates an error upon verification.

`Error: Rung 2, MCR: MCR instruction must be last instruction on rung.`

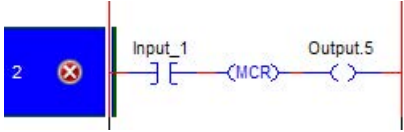
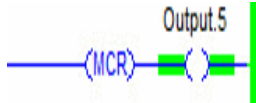
5590/5580/5380 Controllers	5570/5370 Controllers
<p>Project generates error on verification.</p>  <p>The diagram shows a blue box with the number '2' and a red 'X' icon. To its right is a rung starting with a normally open contact labeled 'Input_1'. This is followed by an MCR instruction (a blue circle with 'MCR' inside) and then a coil labeled 'Output.5'. The MCR instruction is not the final element on the rung.</p>	<p>No error is shown. However, it is difficult for programmers to know how the MCR can affect any instructions following it on the rung.</p>  <p>The diagram shows a blue line representing a rung. It starts with an MCR instruction (a blue circle with 'MCR' inside) and ends with a coil labeled 'Output.5'. The MCR instruction is the final element on the rung.</p>

Mitigation

N/A

Data Alignment and Memory Allocation Rules for User-defined Data Types (UDTs) That Contain LINTs

Language	Affected
Ladder Logic (RLL)	Yes
Structured Text (ST)	Yes
Function Blocks (FBD)	Yes
Sequential Function Chart (SFC)	Yes

LINT data types are aligned on 64-bit boundaries in Logix 5000® controllers that use a Logix Designer project, version 27 or later. UDTs that contain LINTs allocate memory in multiples of 8 bytes.

In 5570 and 5370 controllers that use a Logix Designer project, version 26 or earlier, alignment and allocation used 4-byte boundaries. Proper alignment of data improves data integrity and performance.

This implementation affects UDTs that contain LINT data types, including LINTs that are in nested UDTs.

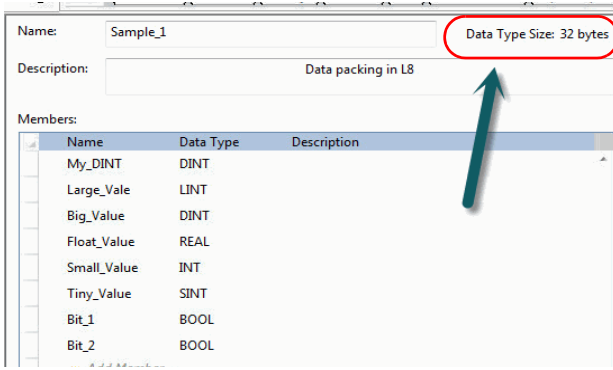
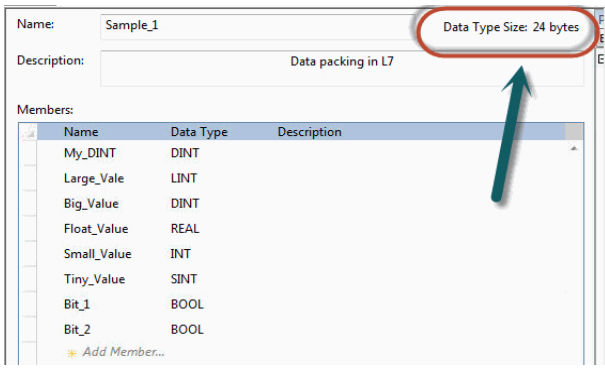
	5590/5580/5380 Controllers		5570/5370 Controllers																																																																																																																										
<p>Data Type Size - 32 bytes</p> 	<p style="text-align: center;">5590/5580/5380 controllers - 64-Bit Boundary</p> <table border="1" style="width: 100%; border-collapse: collapse;"> <thead> <tr> <th rowspan="2">Word</th> <th rowspan="2">Elements</th> <th colspan="5">Data Type</th> </tr> <tr> <th colspan="5">Mapping Table (8 bits each column)</th> </tr> </thead> <tbody> <tr> <td>0</td> <td>My_DINT</td> <td>DINT</td> <td>MAP</td> <td>MAP</td> <td>MAP</td> <td>MAP</td> </tr> <tr> <td>1</td> <td>Padding Bytes</td> <td></td> <td>PAD</td> <td>PAD</td> <td>PAD</td> <td>PAD</td> </tr> <tr> <td>2</td> <td>Large_Value</td> <td>LINT</td> <td>MAP</td> <td>MAP</td> <td>MAP</td> <td>MAP</td> </tr> <tr> <td>3</td> <td></td> <td></td> <td>MAP</td> <td>MAP</td> <td>MAP</td> <td>MAP</td> </tr> <tr> <td>4</td> <td>Big_Value</td> <td>DINT</td> <td>MAP</td> <td>MAP</td> <td>MAP</td> <td>MAP</td> </tr> <tr> <td>5</td> <td>Float_Value</td> <td>REAL</td> <td>MAP</td> <td>MAP</td> <td>MAP</td> <td>MAP</td> </tr> <tr> <td>6</td> <td>Small_Value Tiny_Value, Bit 1 Bit_2</td> <td>INT, SINT, BOOL, BOOL</td> <td>MAP</td> <td>MAP</td> <td>MAP</td> <td>MAP</td> </tr> <tr> <td>7</td> <td>Padding Bytes</td> <td></td> <td>PAD</td> <td>PAD</td> <td>PAD</td> <td>PAD</td> </tr> </tbody> </table>	Word	Elements	Data Type					Mapping Table (8 bits each column)					0	My_DINT	DINT	MAP	MAP	MAP	MAP	1	Padding Bytes		PAD	PAD	PAD	PAD	2	Large_Value	LINT	MAP	MAP	MAP	MAP	3			MAP	MAP	MAP	MAP	4	Big_Value	DINT	MAP	MAP	MAP	MAP	5	Float_Value	REAL	MAP	MAP	MAP	MAP	6	Small_Value Tiny_Value, Bit 1 Bit_2	INT, SINT, BOOL, BOOL	MAP	MAP	MAP	MAP	7	Padding Bytes		PAD	PAD	PAD	PAD	<p>Data Type Size - 24 bytes</p> 	<p style="text-align: center;">5570/5370 controllers - 32-Bit Boundary</p> <table border="1" style="width: 100%; border-collapse: collapse;"> <thead> <tr> <th rowspan="2">Word</th> <th rowspan="2">Elements</th> <th colspan="5">Data Type</th> </tr> <tr> <th colspan="5">Mapping Table (8 bits each column)</th> </tr> </thead> <tbody> <tr> <td>0</td> <td>My_DINT</td> <td>DINT</td> <td>MAP</td> <td>MAP</td> <td>MAP</td> <td>MAP</td> </tr> <tr> <td>1</td> <td>Large_Value</td> <td>LINT</td> <td>MAP</td> <td>MAP</td> <td>MAP</td> <td>MAP</td> </tr> <tr> <td>2</td> <td></td> <td></td> <td>MAP</td> <td>MAP</td> <td>MAP</td> <td>MAP</td> </tr> <tr> <td>3</td> <td>Big_Value</td> <td>DINT</td> <td>MAP</td> <td>MAP</td> <td>MAP</td> <td>MAP</td> </tr> <tr> <td>4</td> <td>Float_Value</td> <td>REAL</td> <td>MAP</td> <td>MAP</td> <td>MAP</td> <td>MAP</td> </tr> <tr> <td>5</td> <td>Small_Value Tiny_Value, Bit 1 Bit_2</td> <td>INT, SINT, BOOL, BOOL</td> <td>MAP</td> <td>MAP</td> <td>MAP</td> <td>MAP</td> </tr> </tbody> </table>	Word	Elements	Data Type					Mapping Table (8 bits each column)					0	My_DINT	DINT	MAP	MAP	MAP	MAP	1	Large_Value	LINT	MAP	MAP	MAP	MAP	2			MAP	MAP	MAP	MAP	3	Big_Value	DINT	MAP	MAP	MAP	MAP	4	Float_Value	REAL	MAP	MAP	MAP	MAP	5	Small_Value Tiny_Value, Bit 1 Bit_2	INT, SINT, BOOL, BOOL	MAP	MAP	MAP	MAP
Word	Elements			Data Type																																																																																																																									
		Mapping Table (8 bits each column)																																																																																																																											
0	My_DINT	DINT	MAP	MAP	MAP	MAP																																																																																																																							
1	Padding Bytes		PAD	PAD	PAD	PAD																																																																																																																							
2	Large_Value	LINT	MAP	MAP	MAP	MAP																																																																																																																							
3			MAP	MAP	MAP	MAP																																																																																																																							
4	Big_Value	DINT	MAP	MAP	MAP	MAP																																																																																																																							
5	Float_Value	REAL	MAP	MAP	MAP	MAP																																																																																																																							
6	Small_Value Tiny_Value, Bit 1 Bit_2	INT, SINT, BOOL, BOOL	MAP	MAP	MAP	MAP																																																																																																																							
7	Padding Bytes		PAD	PAD	PAD	PAD																																																																																																																							
Word	Elements	Data Type																																																																																																																											
		Mapping Table (8 bits each column)																																																																																																																											
0	My_DINT	DINT	MAP	MAP	MAP	MAP																																																																																																																							
1	Large_Value	LINT	MAP	MAP	MAP	MAP																																																																																																																							
2			MAP	MAP	MAP	MAP																																																																																																																							
3	Big_Value	DINT	MAP	MAP	MAP	MAP																																																																																																																							
4	Float_Value	REAL	MAP	MAP	MAP	MAP																																																																																																																							
5	Small_Value Tiny_Value, Bit 1 Bit_2	INT, SINT, BOOL, BOOL	MAP	MAP	MAP	MAP																																																																																																																							

Mitigation

See [Produce and Consume Tags on page 134](#), if you Produce/Consume tags in UDTs between the following:

- 5580 and 5570 controllers that use Logix Designer projects, version 26 or earlier
- 5380 and 5370 controllers that use Logix Designer projects, version 26 or earlier

For more information about mapping, see [Data Structures on page 134](#).

If you use COP or CPS instructions to move data between UDT-based tags and simple arrays, review your logic. Make sure that the COP/CPS instructions are the correct length, and the logic matches the position of the data within the array.

For example, when you use a CPS instruction to copy a SINT[32] array that is obtained from an external device into a UDT that contains LINTs.

SFC Reset Affect on Active Step

Language	Affected
Ladder Logic (RLL)	No
Structured Text (ST)	No
Function Blocks (FBD)	No
Sequential Function Chart (SFC)	Yes

When equipment phase logic performs an SFC Reset on itself while in the same action performing a PSC (Phase State Complete), the phase logic will scan again before the transition to the next phase and update the Active Step to the step specified by the SFC Reset. Previously, the Active Step would remain on the last step that was executed until the next scan of the phase, at which point the step that is specified by the SFC Reset would begin execution.

The logical execution is the same, however if the Active Step is monitored before execution a difference will be observed.

This implementation affects the behavior of the Active Step following a self-referenced SFC Reset

5590/5580/5380 Controllers	5570/5370 Controllers
The Active Step appears as the step specified by the SFC Reset before the next execution	The Active Step appears as the last step executed before the next execution.

Mitigation

If logic is monitoring the active step within an SFC, make sure that this behavior is considered.

Instruction Error and Fault Changes

This section describes the instruction error and fault changes that apply to the following:

- [Subscript Expressions](#)
- [TRN Operator and Math Status Flags](#)
- [Math Status Flags are Valid Only in One Rung](#)
- [AVE and STD Instruction Accuracy](#)
- [BTD, FAL, FSC, and CMP No Longer Generate Math Status](#)
- [Math Status Flags Not Permitted in Structured Text](#)
- [Minor Fault on Overflow](#)
- [Manually Set Math Overflow](#)
- [TOD Instruction Flags and Math Status Flags](#)
- [Add-On Instructions Do Not Propagate Math Status Flags](#)
- [Subroutines Do Not Affect Math Status Flags](#)
- [Carry Flag](#)
- [Store NAN in an Integer](#)
- [Compare NAN Values](#)

IMPORTANT Manually determine the impact to your application and correct accordingly.

Subscript Expressions

Language	Affected
Ladder Logic (RLL)	Yes
Structured Text (ST)	Yes ⁽¹⁾
Function Blocks (FBD)	No
Sequential Function Chart (SFC)	No

(1) Structured Text does not update math flags but REALs in the expression and the major fault is not permitted if the calculated index that is out of range affects ST.

Subscript expressions are treated separately from instructions. If an overflow occurs during their evaluation, the overflow can be recorded as a minor overflow fault but always generates a major fault. The major fault indicates that an out-of-range condition exists.

Subscript expressions behave much more predictably:

- REAL operands/operators are no longer permitted.
- Calculation of subscript expressions no longer silently produces invalid results.
- Overflow conditions are detected and produce a Major Recoverable Fault.

5580/5380 Controllers	5570/5370 Controllers
In these controllers, math errors in subscript calculations do not impact math status flags in any way. Overflow minor faults for subscript expressions are reported if enabled. A major fault is generated if an overflow occurs to indicate that the index was not computed normally.	In these controllers, a subscript calculation changes the value of a math status flag. The change makes it impossible to identify if the instructions or evaluation of a subscript expression that is used with the instruction during operand address processing caused the actual error.

Mitigation

Review all subscript expressions in your application to make sure that they cannot produce an overflow result, for example, a divide-by-zero. Update any major fault recovery logic in your application to handle this new fault appropriately.

TRN Operator and Math Status Flags

Language	Affected
Ladder Logic (RLL)	Yes
Structured Text (ST)	Yes
Function Blocks (FBD)	No
Sequential Function Chart (SFC)	No

TRN operators always produce a 32-bit integer value. When attempting to store that value into a destination too small to hold it, an overflow condition occurs.

While a 5570 or 5370 controller causes a minor overflow fault, it does not set the overflow flag.

CPT instructions that use a TRN operator now produce correct math status.

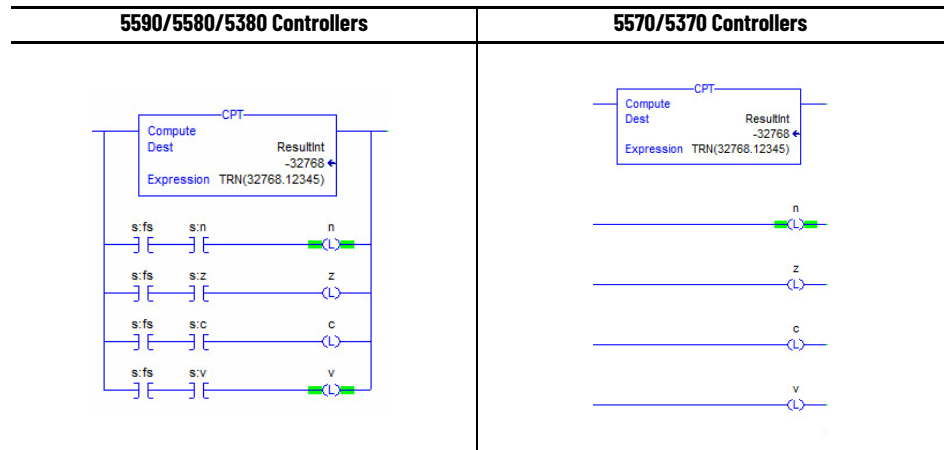

Mitigation

N/A

Math Status Flags are Valid Only in One Rung

Language	Affected
Ladder Logic (RLL)	Yes
Structured Text (ST)	No
Function Blocks (FBD)	No
Sequential Function Chart (SFC)	No

On 5570 and 5370 controllers, the math status flag reflects any math event that occurs anywhere in the routine that performs the evaluation. The ability to identify the instruction that caused the error is a challenge. Also, other instructions that execute correctly after the offending instruction can clear any math status flag errors.

On 5580 and 5380 controllers, the math status flag must reside after an instruction that can set the math status flag. The math status flag reflects the math status that occurred only on the previous instruction that can set the flag within this rung.

This removes the ambiguity as to which instruction caused the math status flag result. The controller does not waste CPU time generating math status flag values if they are not examined.

This implementation affects all math status producer/consumer instructions.

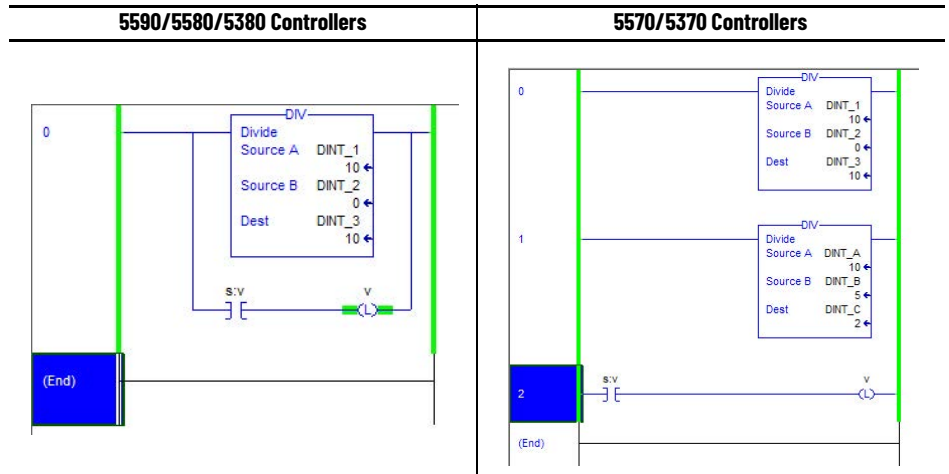

Mitigation

Rearrange logic that evaluates math status flags so that the logic is on the same rung as the flag-generating instruction, and there are no intervening instructions that could affect the flags.

AVE and STD Instruction Accuracy

Language	Affected
Ladder Logic (RLL)	Yes
Structured Text (ST)	No
Function Blocks (FBD)	No
Sequential Function Chart (SFC)	No

The internal data type used for internal calculations of AVE and STD instruction now has greater precision. This improves the accuracy of the results that the AVE and STD instructions generate.

5590/5580/5380 Controllers	5570/5370 Controllers
	<p>(Type 04) Program Fault (Code 04) Arithmetic overflow. Result of an arithmetic instruction out of range. Task: MainTask Program: MainProgram Routine: Inst_Error_faulting_changes Location: Rung 9</p>

Mitigation

N/A

BTD, FAL, FSC, and CMP No Longer Generate Math Status

Language	Affected
Ladder Logic (RLL)	Yes
Structured Text (ST)	No
Function Blocks (FBD)	No
Sequential Function Chart (SFC)	No

The BTD, FAL, FSC, and CMP instructions no longer impact math status flags (S:Z, S:N, S:V) because they do not write a value to a discrete destination. If the minor overflow reporting feature is enabled, BTD, FSC, and CMP instructions report this kind of fault. The FAL no longer generates a minor fault on overflow because the ER bit is set and the operation is aborted.

This removes the expectation that math status has a value for BTD, FAL, FSC, and CMP instructions.

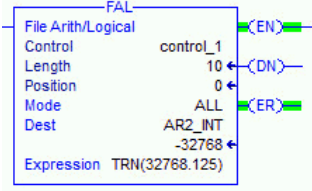
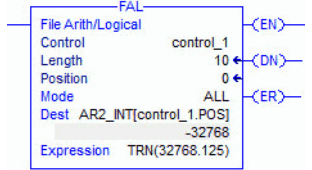
5590/5580/5380 Controllers	5570/5370 Controllers
	<p>There are several situations in which math status flags are generated but you cannot determine exactly where they were generated. One case is with the FAL instruction. If the expression is repeated 10 times, you cannot tell which instance caused the flag.</p>  <pre> 1/3/1998 7:47:09 PM (Type 04) Program Fault (Code 04) Arithmetic overflow. Result of an arithmetic instruction out of range. Task: MainTask Program: MainProgram Routine: Inst_Error_faulting_changes Location: Rung 4 </pre>

Mitigation

N/A

Math Status Flags Not Permitted in Structured Text

Language	Affected
Ladder Logic (RLL)	No
Structured Text (ST)	Yes
Function Blocks (FBD)	No
Sequential Function Chart (SFC)	Yes ⁽¹⁾

(1) Only affects embedded Structured Text.

Math status flags are no longer permitted in ST. Use of math status flags in ST fails verification.

This implementation affects all math status producer/consumer instructions.

5590/5580/5380 Controllers	5570/5370 Controllers
<pre> Tag_1:=(Tag_2/Tag_3)* 25; IF(S:V)Then Status_Flag := 1; Else Status_Flag:=0; End_If; </pre> <p><small>Verifying routine 'LBT93' of program 'MainProgram' Error: Line 2: Math status flag can only be used with Ladder routines.</small></p>	<pre> Tag_1:=(Tag_2/Tag_3)* 25; IF(S:V)Then Status_Flag := 1; Else Status_Flag:=0; End_If; </pre>

Mitigation

Move legacy ST code into an Add-On Instruction that contains equivalent RLL code to emulate math status behavior. Also use Add-On Instruction output parameters to return math status flag-specific values for client to test.

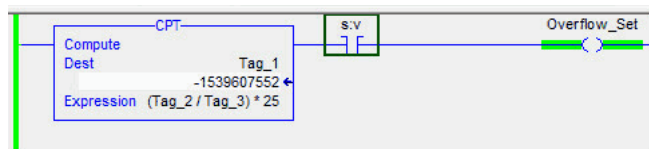

```

STX_Example(STX_AOI,1,Tag_2,Tag_3);
Overflow := STX_AOI.Overflow_Set;
                
```

+ Tag		1	
+ Tag		0	
AOI		0	
Overflow	Local	1	

Minor Fault on Overflow

Language	Affected
Ladder Logic (RLL)	Yes
Structured Text (ST)	Yes
Function Blocks (FBD)	Yes
Sequential Function Chart (SFC)	Yes ⁽¹⁾

(1) Only affects embedded Structured Text.

You can now generate overflow minor faults. Report Overflow Faults is a new parameter that lets you enable Minor Overflow fault reporting.

Report Overflow Faults appears on the Controller Properties Advanced Tab:

- If you convert a legacy project to a 5580 or 5380 project, this parameter defaults to enabled to keep legacy behavior.
- If you create a 5580 or 5380 controller project, this parameter defaults to enabled since numerical overflows have serious impacts on the project functionality.
- In either case, you can override the default by changing the checkbox in the Controller Properties Advanced tab.

Not monitoring overflow events in the minor fault log can reduce controller overhead.

This implementation affects all instructions that can overflow.

5590/5580/5380 Controllers	5570/5370 Controllers
By default, these controllers do NOT trigger a minor fault. <ul style="list-style-type: none"> • If you expect a minor fault condition that you must monitor, use the S:V math status flag following candidate instructions. • If you want to monitor all overflow minor faults, then enable the Report Overflow Faults property on the controller Advanced tab. 	In these controllers, the controller always triggers a minor fault condition when a math overflow occurred.

Mitigation

If you want to monitor overflow conditions for specific instructions capable of generating a minor overflow fault, insert XIC(S:V) immediately following each instruction.

If you want to monitor all possible minor overflow conditions, set Report Overflow Faults on the Controller Properties Advanced Tab and check the minor fault log for their occurrence.



ATTENTION: Enabling Report Overflow Faults can slow down your program scan times.

Manually Set Math Overflow

Language	Affected
Ladder Logic (RLL)	Yes
Structured Text (ST)	No
Function Blocks (FBD)	No
Sequential Function Chart (SFC)	No

You can use overflow flags to help debug your code. Create math overflow conditions where appropriate in your code.

If you used an OTE or OTL instruction to set the overflow flag (S:V), the instruction did not always generate a minor fault with 5570 and 5370 controllers.

When you use an OTE or OTL instruction to set the overflow flag (S:V), the instruction causes an overflow minor fault with 5580 and 5380 controllers:

The fault occurs regardless of the state of the flag before the instruction was executed.

This implementation affects the OTE and OTL instructions.

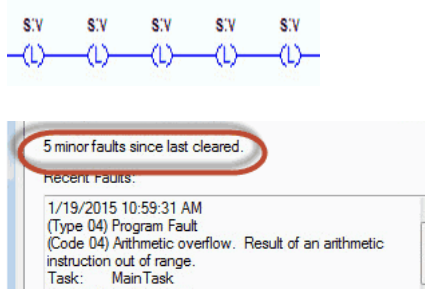
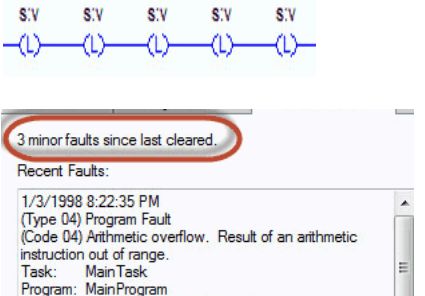
5590/5580/5380 Controllers	5570/5370 Controllers
	

Mitigation

N/A

TOD Instruction Flags and Math Status Flags

Language	Affected
Ladder Logic (RLL)	Yes
Structured Text (ST)	No
Function Blocks (FBD)	No
Sequential Function Chart (SFC)	No

This implementation sets math status flags in a consistent manner across instructions, and offers more complete math status flags for the TOD instruction.

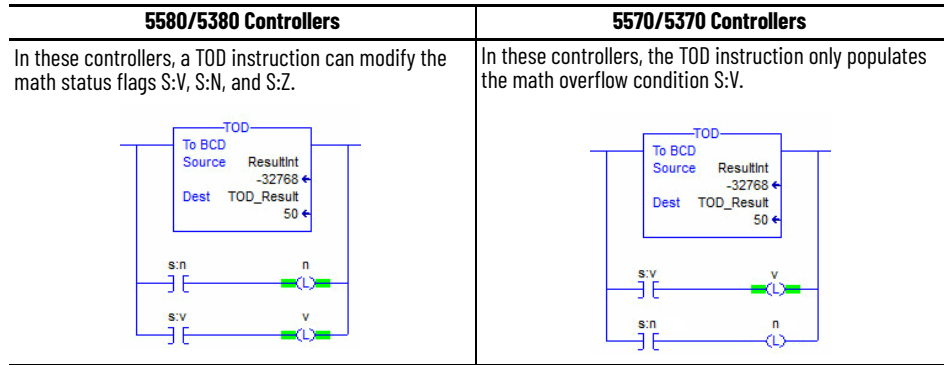

Mitigation

N/A

Add-On Instructions Do Not Propagate Math Status Flags

Language	Affected
Ladder Logic (RLL)	Yes
Structured Text (ST)	No
Function Blocks (FBD)	No
Sequential Function Chart (SFC)	Yes ⁽¹⁾

(1) Only affects embedded Structured Text.

When the content of an Add-On Instruction generates a math status flag, the status is not propagated to the routine or other Add-On Instructions that call the offending Add-On Instruction. Add-On Instructions are not considered producers of Math Status Flags. Math status flags can be evaluated in the Add-On Instruction, but not by the caller.

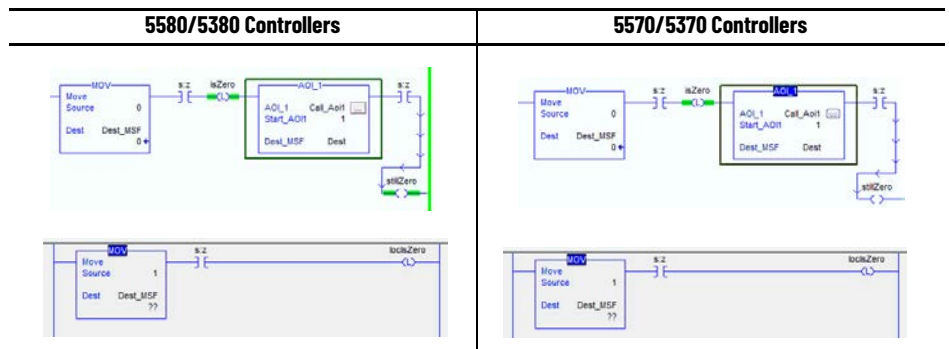

Mitigation

If you want the Add-On Instruction to return math status flags, then use Boolean output parameters.

Subroutines Do Not Affect Math Status Flags

Language	Affected
Ladder Logic (RLL)	Yes
Structured Text (ST)	No
Function Blocks (FBD)	No
Sequential Function Chart (SFC)	Yes ⁽¹⁾

(1) Only affects embedded Structured Text.

Subroutines are not considered MSF producers, so they do not preserve math status flags across calls. The JSR, SBR, RET, FOR, BRK instructions are not math status flags producers. FOR and BRK instructions do not affect math status flags because they do not pass any parameters.

The JSR instruction saves (and reinitializes) the flags on entry and restores them after the subroutine returns. Also, the SBR, RET, FOR, and BRK instructions do not change the flags.

This implementation affects the JSR and FOR instructions. FOR is only available in RLL.

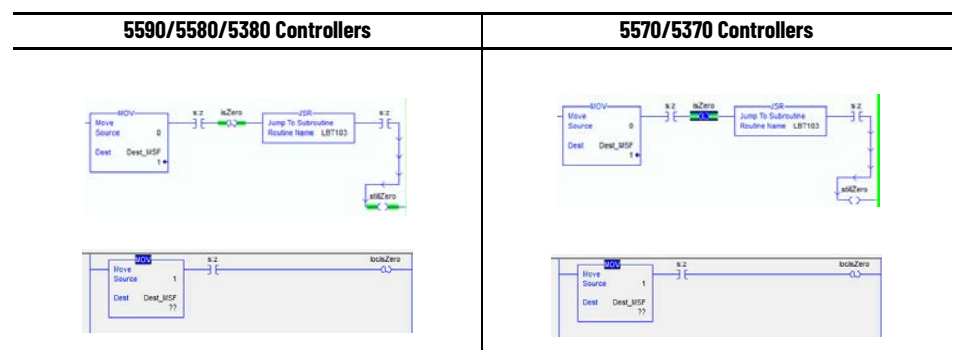

Mitigation

N/A

Carry Flag

Language	Affected
Ladder Logic (RLL)	Yes
Structured Text (ST)	Yes
Function Blocks (FBD)	No
Sequential Function Chart (SFC)	Yes ⁽¹⁾

(1) Only affects embedded Structured Text.

Only the ADD and SUB instructions that specify integer operands can affect the carry bit. This lets you perform chain calculations to support larger (unsupported) data types (Add_low, Add_with_carry high).

The carry flag is limited to only those operations that are relevant. This simplifies its use and that of math status flags in general.

This implementation affects all instructions that can set math status flags.

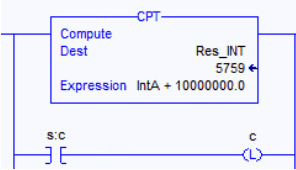
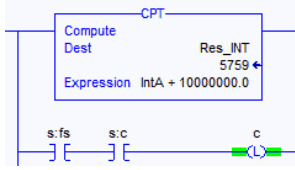
5590/5580/5380 Controllers	5570/5370 Controllers
<p>Use of the ADD and SUB operators has no effect on the carry bit. Only ADD and SUB instructions with integer operands can affect the Carry flag.</p> 	<p>Many math instructions can set the carry bit.</p> 

Mitigation

Look for references to s:c in the user project and verify that the logic functions as intended.

Store NAN in an Integer

Language	Affected
Ladder Logic (RLL)	Yes
Structured Text (ST)	Yes
Function Blocks (FBD)	Yes
Sequential Function Chart (SFC)	Yes ⁽¹⁾

(1) Only affects the embedded Structured Text.

When writing/propagating NAN values, 5590, 5580, and 5380 controllers offer standardized results. This implementation affects all instructions that can produce a Floating Point value and store in an integer location.

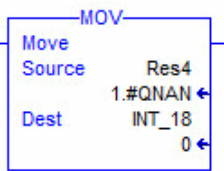
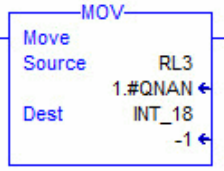
5590/5580/5380 Controllers	5570/5370 Controllers
<p>Writing +/- NAN to an integer always results in the value 0 be stored.</p> 	<p>Writing NAN to an integer results in either -1 or 0 depending on the sign bit for NAN.</p> 

Mitigation

Revise your application if it was checking for the special value of '-1' to indicate a '-NAN' result.

Compare NAN Values

Language	Affected
Ladder Logic (RLL)	Yes
Structured Text (ST)	No
Function Blocks (FBD)	Yes
Sequential Function Chart (SFC)	No

NAN does not compare true with ANY value (even another NAN). Any EQU, GEQ, GRT, LEQ, or LES comparison with at least one NAN input is always false, and any NEQ input with at least one NAN input is always true. Now offers standardized results when you use NAN in comparisons.

This implementation affects these instructions: CMP, EQU, GEQ, GRT, LEQ, LES, NEQ.

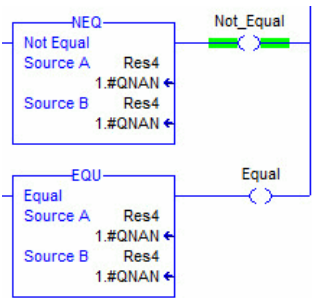
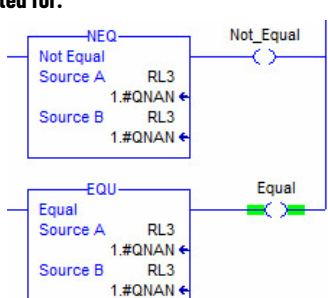
5590/5580/5380 Controllers	5570/5370 Controllers
<p>All compares with NAN are false except for NEQ.</p> 	<p>NAN values compare as equals and their signs are accounted for.</p> 

Mitigation

Revise any logic that relies on the old, non-standard result from a NAN comparison. Also, it is now easier to test for a NAN result. This value is the only value that provides a true result for a 'NEQ TagA TagA' comparison.

Operand Changes

This section describes the changes to operands.

IMPORTANT Manually determine the impact to your application and correct accordingly.

Converting +/- Infinity

Language	Affected
Ladder Logic (RLL)	Yes
Structured Text (ST)	Yes
Function Blocks (FBD)	Yes
Sequential Function Chart (SFC)	Yes ⁽¹⁾

(1) Only affects the embedded Structured Text.

Converting +/-Infinity to an integer results in MAX signed integer value with MS flags set based on the value. For 32-bit integer machines, this means 2147483647 for +Inf and -2147483648 for -Inf. Overflow (V) is always set.

When writing/propagating +/- infinity values, 5590, 5580 and 5380 controllers offer more standardized results.

MAX/MIN values are less common than 0 or -1 meaning there is less conflict with common program results.

This implementation affects all instructions that store floating point values into integer locations. Applicable to all languages.

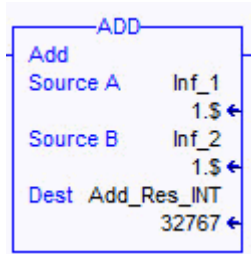
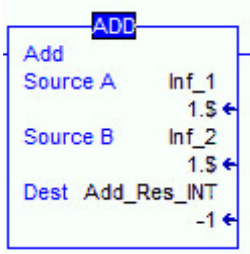
5590/5580/5380 Controllers	5570/5370 Controllers
<p>Writing infinity to an integer is the MAX signed value that is permitted.</p> 	<p>Writing +infinity to an integer is -1 value whereas -infinity is stored as 0 in an integer.</p> 

Mitigation

N/A

Copy/File Instructions

This section describes the changes to copy/file instructions that apply to the following:

- [COP and CPS Into Structures](#)
- [JSR and RET Parameters Passing Into Structures](#)
- [JSR Passing Atomic Data Type into an Array or Structure](#)
- [Instructions That Operate On Arrays](#)

IMPORTANT Manually determine the impact to your application and correct accordingly.

COP and CPS Into Structures

Language	Affected
Ladder Logic (RLL)	Yes
Structured Text (ST)	Yes
Function Blocks (FBD)	Yes
Sequential Function Chart (SFC)	Yes ⁽¹⁾

(1) Only affects embedded Structured Text.

Copying a 10-element array into a 100-element array now moves 10 elements (limited by the source). As always, copying a 100-element array into a 10-element array only moves the first 10 elements of the source (limited by the destination).

5590/5580/5380 Controllers		5570/5370 Controllers	
<p>The ControlLogix 5590 (safety-enabled), GuardLogix 5580, and Compact GuardLogix 5380 controllers remove the possibility of a major fault due to a memory miscompare between the primary controller and the safety partner.</p>		<p>These random values can cause a major fault in the GuardLogix 5570 and Compact GuardLogix 5370 controllers due to a memory miscompare between the primary controller and the safety partner.</p>	

Mitigation

N/A

JSR and RET Parameters Passing Into Structures

Language	Affected
Ladder Logic (RLL)	Yes
Structured Text (ST)	Yes
Function Blocks (FBD)	Yes
Sequential Function Chart (SFC)	Yes ⁽¹⁾

(1) Only affects embedded Structured Text.

Parameters that pass from JSR (into subroutine) and RET (back to JSR) only use the size of the smaller structure (either source or destination) for the copy. Copies that are made into smaller destinations no longer overrun target arrays or structures.

5590/5580/5380 Controllers	5570/5370 Controllers																																																																																																																																																																																				
JSR Return Par = Return_Par_Array[5] RET Return Par = Test_Array[10]	JSR Return Par = Return_Par_Array[5] RET Return Par = Test_Array[10]																																																																																																																																																																																				
<table border="1"> <thead> <tr> <th>Test_Array</th> <th>Local</th> <th>(...)</th> <th>(</th> </tr> </thead> <tbody> <tr><td>+ Test_Array[0]</td><td></td><td>1</td><td></td></tr> <tr><td>+ Test_Array[1]</td><td></td><td>2</td><td></td></tr> <tr><td>+ Test_Array[2]</td><td></td><td>3</td><td></td></tr> <tr><td>+ Test_Array[3]</td><td></td><td>4</td><td></td></tr> <tr><td>+ Test_Array[4]</td><td></td><td>5</td><td></td></tr> <tr><td>+ Test_Array[5]</td><td></td><td>6</td><td></td></tr> <tr><td>+ Test_Array[6]</td><td></td><td>7</td><td></td></tr> <tr><td>+ Test_Array[7]</td><td></td><td>8</td><td></td></tr> <tr><td>+ Test_Array[8]</td><td></td><td>9</td><td></td></tr> <tr><td>+ Test_Array[9]</td><td></td><td>10</td><td></td></tr> <tr><td>- Return_Par</td><td>Local</td><td>(...)</td><td>(</td></tr> <tr><td>- Return_Par Array</td><td></td><td>(...)</td><td>(</td></tr> <tr><td>+ Return_Par Array[0]</td><td></td><td>1</td><td></td></tr> <tr><td>+ Return_Par Array[1]</td><td></td><td>2</td><td></td></tr> <tr><td>+ Return_Par Array[2]</td><td></td><td>3</td><td></td></tr> <tr><td>+ Return_Par Array[3]</td><td></td><td>4</td><td></td></tr> <tr><td>+ Return_Par Array[4]</td><td></td><td>5</td><td></td></tr> <tr><td>+ Return_Par Dint2</td><td></td><td>0</td><td></td></tr> <tr><td>+ Return_Par Dint3</td><td></td><td>0</td><td></td></tr> <tr><td>+ Return_Par Dint4</td><td></td><td>0</td><td></td></tr> <tr><td>+ Return_Par Dint5</td><td></td><td>0</td><td></td></tr> </tbody> </table>	Test_Array	Local	(...)	(+ Test_Array[0]		1		+ Test_Array[1]		2		+ Test_Array[2]		3		+ Test_Array[3]		4		+ Test_Array[4]		5		+ Test_Array[5]		6		+ Test_Array[6]		7		+ Test_Array[7]		8		+ Test_Array[8]		9		+ Test_Array[9]		10		- Return_Par	Local	(...)	(- Return_Par Array		(...)	(+ Return_Par Array[0]		1		+ Return_Par Array[1]		2		+ Return_Par Array[2]		3		+ Return_Par Array[3]		4		+ Return_Par Array[4]		5		+ Return_Par Dint2		0		+ Return_Par Dint3		0		+ Return_Par Dint4		0		+ Return_Par Dint5		0		<table border="1"> <thead> <tr> <th>Test_Array</th> <th>Local</th> <th>(...)</th> <th>(</th> </tr> </thead> <tbody> <tr><td>+ Test_Array[0]</td><td></td><td>1</td><td></td></tr> <tr><td>+ Test_Array[1]</td><td></td><td>2</td><td></td></tr> <tr><td>+ Test_Array[2]</td><td></td><td>3</td><td></td></tr> <tr><td>+ Test_Array[3]</td><td></td><td>4</td><td></td></tr> <tr><td>+ Test_Array[4]</td><td></td><td>5</td><td></td></tr> <tr><td>+ Test_Array[5]</td><td></td><td>6</td><td></td></tr> <tr><td>+ Test_Array[6]</td><td></td><td>7</td><td></td></tr> <tr><td>+ Test_Array[7]</td><td></td><td>8</td><td></td></tr> <tr><td>+ Test_Array[8]</td><td></td><td>9</td><td></td></tr> <tr><td>+ Test_Array[9]</td><td></td><td>10</td><td></td></tr> <tr><td>- Return_Par</td><td>Local</td><td>(...)</td><td>(</td></tr> <tr><td>- Return_Par Array1</td><td></td><td>(...)</td><td>(</td></tr> <tr><td>+ Return_Par Array1</td><td></td><td>1</td><td></td></tr> <tr><td>+ Return_Par Array1</td><td></td><td>2</td><td></td></tr> <tr><td>+ Return_Par Array1</td><td></td><td>3</td><td></td></tr> <tr><td>+ Return_Par Array1</td><td></td><td>4</td><td></td></tr> <tr><td>+ Return_Par Array1</td><td></td><td>5</td><td></td></tr> <tr><td>+ Return_Par Dint2</td><td></td><td>7</td><td></td></tr> <tr><td>+ Return_Par Dint3</td><td></td><td>8</td><td></td></tr> <tr><td>+ Return_Par Dint4</td><td></td><td>9</td><td></td></tr> <tr><td>+ Return_Par Dint5</td><td></td><td>10</td><td></td></tr> <tr><td>- Return_Par Real1</td><td></td><td>6.40179019e+043</td><td></td></tr> </tbody> </table>	Test_Array	Local	(...)	(+ Test_Array[0]		1		+ Test_Array[1]		2		+ Test_Array[2]		3		+ Test_Array[3]		4		+ Test_Array[4]		5		+ Test_Array[5]		6		+ Test_Array[6]		7		+ Test_Array[7]		8		+ Test_Array[8]		9		+ Test_Array[9]		10		- Return_Par	Local	(...)	(- Return_Par Array1		(...)	(+ Return_Par Array1		1		+ Return_Par Array1		2		+ Return_Par Array1		3		+ Return_Par Array1		4		+ Return_Par Array1		5		+ Return_Par Dint2		7		+ Return_Par Dint3		8		+ Return_Par Dint4		9		+ Return_Par Dint5		10		- Return_Par Real1		6.40179019e+043	
Test_Array	Local	(...)	(
+ Test_Array[0]		1																																																																																																																																																																																			
+ Test_Array[1]		2																																																																																																																																																																																			
+ Test_Array[2]		3																																																																																																																																																																																			
+ Test_Array[3]		4																																																																																																																																																																																			
+ Test_Array[4]		5																																																																																																																																																																																			
+ Test_Array[5]		6																																																																																																																																																																																			
+ Test_Array[6]		7																																																																																																																																																																																			
+ Test_Array[7]		8																																																																																																																																																																																			
+ Test_Array[8]		9																																																																																																																																																																																			
+ Test_Array[9]		10																																																																																																																																																																																			
- Return_Par	Local	(...)	(
- Return_Par Array		(...)	(
+ Return_Par Array[0]		1																																																																																																																																																																																			
+ Return_Par Array[1]		2																																																																																																																																																																																			
+ Return_Par Array[2]		3																																																																																																																																																																																			
+ Return_Par Array[3]		4																																																																																																																																																																																			
+ Return_Par Array[4]		5																																																																																																																																																																																			
+ Return_Par Dint2		0																																																																																																																																																																																			
+ Return_Par Dint3		0																																																																																																																																																																																			
+ Return_Par Dint4		0																																																																																																																																																																																			
+ Return_Par Dint5		0																																																																																																																																																																																			
Test_Array	Local	(...)	(
+ Test_Array[0]		1																																																																																																																																																																																			
+ Test_Array[1]		2																																																																																																																																																																																			
+ Test_Array[2]		3																																																																																																																																																																																			
+ Test_Array[3]		4																																																																																																																																																																																			
+ Test_Array[4]		5																																																																																																																																																																																			
+ Test_Array[5]		6																																																																																																																																																																																			
+ Test_Array[6]		7																																																																																																																																																																																			
+ Test_Array[7]		8																																																																																																																																																																																			
+ Test_Array[8]		9																																																																																																																																																																																			
+ Test_Array[9]		10																																																																																																																																																																																			
- Return_Par	Local	(...)	(
- Return_Par Array1		(...)	(
+ Return_Par Array1		1																																																																																																																																																																																			
+ Return_Par Array1		2																																																																																																																																																																																			
+ Return_Par Array1		3																																																																																																																																																																																			
+ Return_Par Array1		4																																																																																																																																																																																			
+ Return_Par Array1		5																																																																																																																																																																																			
+ Return_Par Dint2		7																																																																																																																																																																																			
+ Return_Par Dint3		8																																																																																																																																																																																			
+ Return_Par Dint4		9																																																																																																																																																																																			
+ Return_Par Dint5		10																																																																																																																																																																																			
- Return_Par Real1		6.40179019e+043																																																																																																																																																																																			

Mitigation

N/A

JSR Passing Atomic Data Type into an Array or Structure

Language	Affected
Ladder Logic (RLL)	Yes
Structured Text (ST)	Yes
Function Blocks (FBD)	Yes
Sequential Function Chart (SFC)	Yes ⁽¹⁾

(1) Only affects embedded Structured Text.

If a JSR passed an atomic data element as an input to a subroutine, and that subroutine stores it in an array or structure, then only parts of the target array were populated with 5570 and 5370 controllers:

4 bytes are always copied regardless of the atomic data type with these controllers. The exception is if the destination is less than 4 bytes. Then the entire destination is copied over for 5580 and 5380 controllers.

This implementation affects the JSR and SBR instructions.

5590/5580/5380 Controllers	5570/5370 Controllers
<div style="text-align: center;"> </div> <div style="text-align: center;"> </div> <p>4 bytes are always copied unless the destination structure is smaller than 4 bytes. MyAtomic (SINT) = -1 MyArray Before the copy MyArray[0] = 100 MyArray[1] = 100 MyArray[2] = 100 MyArray[3] = 100 MyArray[4] = 100 MyArray[5] = 100 MyArray[6] = 100</p> <p>If MyArray = SINT structure After the copy MyArray[0] = -1 MyArray[1] = 100 MyArray[2] = 100 MyArray[3] = 100 MyArray[4] = 100 MyArray[5] = 100 MyArray[6] = 100</p>	<div style="text-align: center;"> </div> <div style="text-align: center;"> </div> <p>Only the first number of the array is stored.</p> <ul style="list-style-type: none"> • If the destination array is bool array, bool_array[0] is updated, this is only 1 bit. • If the destination array is sint array, sint_array[0] is updated, this is 1 byte. • If the destination array is int array, int_array[0] is updated, this is 2 bytes. • If the destination array is dint array, dint_array[0] is updated, this is 4 bytes. • If the destination array is real array, real_array[0] is updated, this is 4 bytes. <p>MyAtomic (SINT) = -1 MyArray Before the copy MyArray[0] = 100 MyArray[1] = 100 MyArray[2] = 100 MyArray[3] = 100 MyArray[4] = 100 MyArray[5] = 100 MyArray[6] = 100</p> <p>If MyArray = SINT structure After the copy MyArray[0] = -1 MyArray[1] = 100 MyArray[2] = 100 MyArray[3] = 100 MyArray[4] = 100 MyArray[5] = 100 MyArray[6] = 100</p>

5590/5580/5380 Controllers	5570/5370 Controllers
If MyAtomic (DINT) = -1 If MyArray = SINT structure After the copy MyArray[0] = -1 MyArray[1] = -1 MyArray[2] = -1 MyArray[3] = -1 MyArray[4] = 100 MyArray[5] = 100 MyArray[6] = 100 If MyAtomic (DINT) = -1 If MyArray = Bool structure After the copy MyArray[0] = 1 MyArray[1] = 1 MyArray[2] = 1 MyArray[3] = 1 MyArray[4] = 1 MyArray[5] = 1 MyArray[6] = 1 MyArray[7] = 1 MyArray[8] = 1 MyArray[9] = 1 MyArray[10] = 1 MyArray[11] = 1 MyArray[12] = 1 MyArray[13] = 1 MyArray[31] = 1	If MyAtomic (DINT) = -1 If MyArray = SINT structure After the copy MyArray[0] = -1 MyArray[1] = 100 MyArray[2] = 100 MyArray[3] = 100 MyArray[4] = 100 MyArray[5] = 100 MyArray[6] = 100 If MyAtomic (DINT) = -1 If MyArray = Bool structure After the copy MyArray[0] = 1 MyArray[1] = 0 MyArray[2] = 0 MyArray[3] = 0 MyArray[4] = 0 MyArray[5] = 0 MyArray[6] = 0 MyArray[7] = 0 MyArray[8] = 0 MyArray[9] = 0 MyArray[10] = 0 MyArray[11] = 0 MyArray[12] = 0 MyArray[13] = 0 MyArray[31] = 0

Mitigation

N/A

Instructions That Operate On Arrays

Language	Affected
Ladder Logic (RLL)	Yes
Structured Text (ST)	No
Function Blocks (FBD)	No
Sequential Function Chart (SFC)	No

Instruction actions are limited to member array boundaries. If any of these instructions attempt to access past the end of a member array, they set the ER bit and close the operation.

AVE, BSL, BSR, DDT, FBC, FFL, FFU, LFL, LFU, SQL, SRT, and STD now respect boundaries when reading.

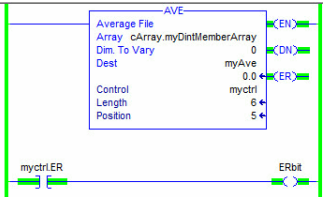
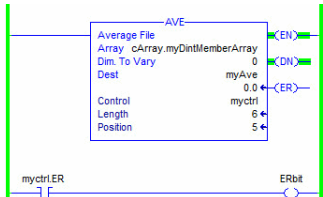
5590/5580/5380 Controllers	5570/5370 Controllers
<p>These instructions are now limited to member array boundaries.</p> 	<p>In previous controllers, these instructions could overwrite member boundaries if the array was within a UDT.</p> 

Mitigation

N/A

GSV/SSV Instructions

GSV and SSV instructions that access unused attributes in 5580 and 5380 controller projects display this verification warning.

IMPORTANT Rung <n>, GSV, Operand 2: Attribute is not used for this controller type. Instruction has no effect.

Figure 32 - GSV/SSV of Controller Attributes

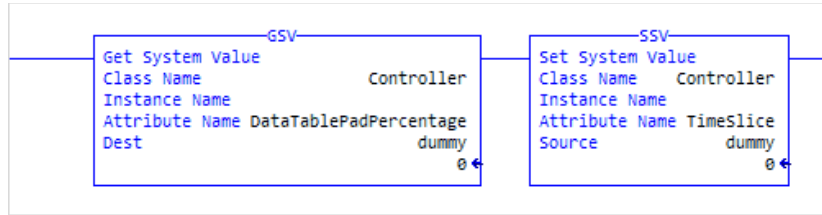

The warning occurs for the following controller attributes:

- DataTablePadPercentage. (GSV only)
- TimeSlice (GSV/SSV)
- ShareUnusedTimeSlice (GSV / SSV)

MCT/MCTP Instructions

The Motion Coordinated Transform (MCT) and Motion Calculate Transform Position (MCTP) instructions are different regarding source and target transform dimensions.

With version 29 or earlier, the controllers allowed the following MCT/MCTP associations:

- Cartesian-Cartesian (TD=[1,2],[1,3],[2,3])
- Cartesian-Articulated independent and dependent (TD=[2,3])

Version 30 or later does not support cases where the Coordinate System Dimension is not Equal to the Transform Dimension, and checks to make sure the dimensions match.

If the dimensions do not match, the Motion Instruction Status shows Error Code 61, with extended Error Code 17: "Make sure the Transform Dimension attribute on the Source and Target are equal."

Diagnostics and Status Indicators with ControlLogix Systems

This chapter features these controllers, and where applicable, the controllers are known as:

Controller Family	Includes these controllers
5590 controllers	ControlLogix® 5590 controllers
5580 controllers	ControlLogix 5580 and GuardLogix® 5580 controllers
5570 controllers	ControlLogix 5570 and GuardLogix 5570 controllers

You can diagnose and troubleshoot the 5590, 5580, and 5570 Controllers with:

- [Controller Status Display and Indicators on page 179](#)
- [Controller Web Pages on page 183](#)

Controller Status Display and Indicators

5590, 5580, and 5570 controllers have the following:

- 5590 controllers - 4-character display, four status indicators and four Ethernet indicators (two each for Network and Link, respectively)
- 5580 controllers - 4-character display, four status indicators and four Ethernet indicators (two each for Network and Link, respectively)
- 5570 controllers - 4-character display, and four status indicators

4-Character Display

The 4-character display on the 5590 controllers shows the same messages as the 5580 and 5570 controllers and some that are specific to 5590 controllers.

IMPORTANT

Because the 5590 controllers have two Ethernet ports, some of the messages are slightly different with those controllers. For example, when a 5590 controller operates in Dual-IP mode, it has a unique IP address for each port. In that case, the IP Address message indicates the IP address for each port. If IP addresses are not assigned to the ports, the 5590 controllers' messages show separate MAC addresses, one for each port.

The table below lists some of the general status messages that can scroll across the display. For information about more detailed controller conditions and a full list of messages, see the following:

- ControlLogix 5590 Controllers User Manual, publication [1756-UM900](#).
- ControlLogix 5580 and GuardLogix 5580 Controllers User Manual, publication [1756-UM543](#).

Message	Interpretation
Link Down	The message appears when the EtherNet/IP port does not have a connection. The message scrolls continuously during operation. IMPORTANT: When a 5590 controller operates in Dual-IP mode, this information is provided for each link, that is, Link A1 and Link A2. The link name appears before the information.
Link Disabled	The message appears when you have disabled the EtherNet/IP port. The message scrolls continuously during operation. IMPORTANT: When a 5590 controller operates in Dual-IP mode, this information is provided for each link, that is, Link A1 and Link A2. The link name appears before the information.
DHCP- 00:00:XX:XX:XX:XX	The message appears when the controller is set for DHCP, but not configured on a network. The message shows the MAC address of the controller. The message scrolls continuously during operation if no IP address is set. IMPORTANT: When a 5590 controller operates in Dual-IP mode, this information is provided for Port 1 and Port 2. The port name appears before the information.
Ethernet Port Rate/Duplex State	The current port rate and duplex state when the EtherNet/IP port has a connection. The message scrolls continuously during operation. IMPORTANT: When a 5590 controller operates in Dual-IP mode, this information is provided for each link, that is, Link A1 and Link A2. The link name appears before the information.
IP address	The IP address of the controller. Appears on powerup, then scrolls continuously during operation. If the IP address is not yet set, then the MAC address appears. IMPORTANT: When a 5590 controller operates in Dual-IP mode, this information is provided for Port 1 and Port 2. The port name appears before the information.
Duplicate IP - 00:00:XX:XX:XX:XX	The message appears when the controller detects a device on the network that has the same IP address as the controller Ethernet port. The message shows the MAC address of the device with the duplicate IP address. The message scrolls continuously during operation. IMPORTANT: When a 5590 controller operates in Dual-IP mode, this information is provided for Port 1 and Port 2. The port name appears before the information.
Backup Energy HW Failure - Save Project	A failure with the embedded storage circuit has occurred, and the controller is incapable of saving the program if a powerdown occurs. If you see this message, then save your program to the SD card before you remove power, and then replace the controller.
Backup Energy Low - Save Project	The embedded storage circuit does not have sufficient energy to enable the controller to save the program if a powerdown occurs. If you see this message, then save your program to the SD card before you remove power, and then replace the controller.
5590 Controller only	
Link <x>:crossload-redund-en	The message appears when the controller is configured for front port synchronization and shows the relevant Ethernet ports (1 or 1/2). The message scrolls continuously during operation.

Status Indicators

5590 controllers use a MOD status indicator instead of the OK status indicators that is used on 5580 controllers.

The Run, Force, and SD status indicators function the same as the 5580 controllers.

MOD Status Indicator - 5590 Controllers

The MOD status indicator on 5590 controllers shows the state of the controller.

State	Description
Off	No power is applied to the controller.
Steady red	The controller has a Major Unrecoverable Fault
Flashing red	The controller has a Major Recoverable Fault.
Steady green	The controller is operating normally.
Flashing green	The device is in one of the following states: <ul style="list-style-type: none"> The device is not configured. The module requires a firmware update. Firmware update in progress. The module is saving a project to internal or external non-volatile memory. The charge of the capacitor in the ESM is being discharged upon powerdown. The module is experiencing a Hardware Preservation Fault due to a high internal module temperature. In this condition, only the status indicator receives power. Once the module cools down to an acceptable temperature, then full power is applied.
Flashing green/red	The device is performing its power up testing.

OK Status Indicator - 5580 and 5570 Controllers

The OK status indicator on 5580 and 5570 controllers shows the state of the controller.

State	Description
Off	No power is applied to the controller.
Steady red	One of the following is true: <ul style="list-style-type: none"> The controller is completing power-up diagnostics. The charge of the capacitor in the ESM is being discharged upon powerdown. The controller is powered, but is inoperable. The controller is loading a project to nonvolatile memory. 5580 controllers only - The controller is experiencing a Hardware Preservation Fault due to a high internal module temperature. In this condition, only the status indicator receives power. Once the controller cools down to an acceptable temperature, then full power is applied.
Flashing red	One of the following is true: <ul style="list-style-type: none"> It is a new controller, out of the box, and it requires a firmware update. If a firmware update is required, the status display indicates Firmware Installation Required. It is a previously used or in-use controller and a major fault has occurred. All user tasks, standard and safety, are stopped. For details about major recoverable and nonrecoverable faults, see the Logix 5000 Major, Minor, and I/O Fault Codes Programming Manual, publication 1756-PM014 .
Steady green	The controller is operating normally.

Ethernet Indicators

IMPORTANT The 5570 controllers do not have Ethernet indicators because they do not have a built-in Ethernet port.

The Ethernet indicators show the state of the Ethernet port and communications activity. There are two NET and two LINK indicators on the controllers. The indicators are the same between the 5580 controllers and the 5590 controllers with the exception of those noted below.

Indicator	State	Description
NET	Off	<ul style="list-style-type: none"> The controller is not configured, or does not have an IP address. The port is administratively disabled. With the 5590 controllers, the EtherNet/IP mode Linear/DLR mode. In this case, the NET A2 indicator is off. The NET A1 indicator remains on.
	Flashing green	The controller has an IP address, but no active connections are established.
	Steady green	The controller has an IP address and at least one established active connection.
	Steady red	Duplicate IP Address or invalid configuration.
LINK	Off	No activity. One of these conditions exists: <ul style="list-style-type: none"> No link exists on the port. Verify that the RJ45 cables are properly seated in the adapter and connected devices. The port is administratively disabled. With the 5590 controllers, on LINK A2 only, the controller is the active ring supervisor in a DLR network and has detected a rapid ring fault.
	Flashing green	All of these conditions exist: <ul style="list-style-type: none"> The port is enabled. A link exists. That is, the cable is properly connected to an enabled controller Ethernet port on to another device. There is activity on the port.
	Steady green	With 5590 controllers, all of the following conditions exist: <ul style="list-style-type: none"> The port is enabled. A link exists. That is, the cable is properly connected to an enabled controller Ethernet port and to another device. LINK A2 only - The controller is the active ring supervisor in a DLR network, and the ring is not broken. This is normal operation. There is no activity on the port.

Controller Web Pages

The 5590 and 5580 controllers provide diagnostic web pages that track controller performance, network performance, and backplane performance.

The 5590 controllers' web pages differ in appearance based on the EtherNet/IP™ mode selection, that is, Dual-IP mode or Linear/DLR mode.

The 5570 controllers do not provide controller web pages because they do not have a built-in Ethernet port.

IMPORTANT

With the Studio 5000 Logix Designer® application version 33.00.00 and later, controller web pages are disabled by default.

- To enable the controller web pages, select the checkbox on the Logix Designer Controller Properties Security tab.

This example shows the Controller Properties dialog box for a 5590 controller, Logix Designer application, version 38. The dialog box might appear slightly different for 5580 controllers and different Logix Designer application versions.

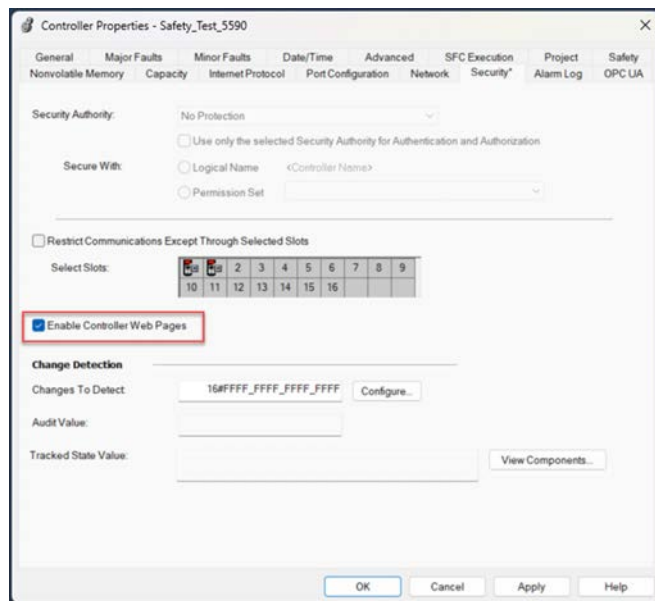

- For CIP Security™ applications, you can also use FactoryTalk® Policy Manager to enable or disable the webpages (this overrides the Controller Properties checkbox).

To access the diagnostic web pages, follow these steps.

1. Open your web browser.
2. In the Address field, type the IP address of the controller and press Enter.

To access the diagnostic web pages, open the Diagnostics folder in the leftmost navigation bar, and click the link for each diagnostic web page that you want to monitor.

- The Diagnostics web pages provide communications and messaging data for the controller.
- The Advanced diagnostics web pages provide data about the TCP/IP Network and Precision Time Protocol.

Home Web Page

The Home page provides device information and controller status.

5580 Controllers

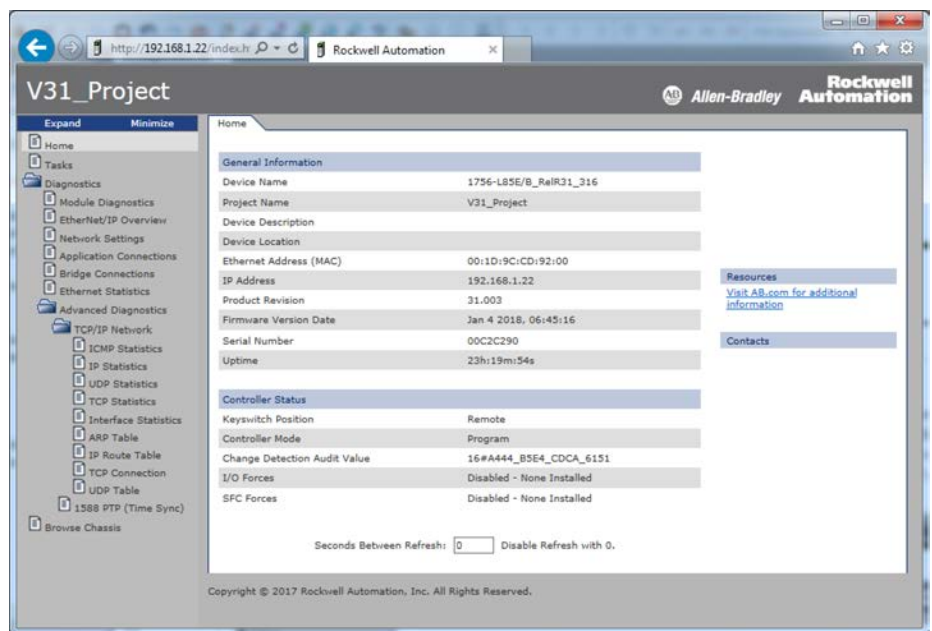

5590 Controllers

Dual-IP Mode

The screenshot shows the Rockwell Automation web interface for a ControlLogix 5590 controller in Dual-IP Mode. The browser address is 192.168.120/index.html. The left sidebar shows a navigation tree with 'Diagnostics' expanded to 'Ethernet Port 1' and 'Ethernet Port 2'. The main content area displays the following information:

General Information		Resources
Device Name	ControlLogix 5590 Controller	Visit AB.com for additional information
Project Name	Safety_Test_5590	
Device Description		Contacts
Device Location		
Product Revision	38.011	
Firmware Version Date	Aug 21 2025, 19:25:57	
Serial Number	0167A672	
Uptime	00h:57m:47s	
Port 1 Ethernet Address (MAC)	08-61:95:E8:93:97	
Port 1 IP Address	192.168.1.20	
Port 2 Ethernet Address (MAC)	08-61:95:E8:93:98	
Port 2 IP Address	192.168.2.1	

Controller Diagnostics	
Keyswitch Position	Run
Controller Mode	Run
Change Detection Audit Value	16#25FC_BF75_522A_FA67
I/O Forces	Disabled - None Installed
SFC Forces	Disabled - None Installed

Safety Controller Diagnostics	
Safety Signature	Non-existing
Safety Locked Status	Unlocked
Safety Status	SIL-3 Safety Task OK

Status Indicators	
Controller Status	<input checked="" type="checkbox"/> Run <input type="checkbox"/> Force <input type="checkbox"/> SD <input type="checkbox"/> Mod
EtherNet/IP Status	<input checked="" type="checkbox"/> Net 1 <input checked="" type="checkbox"/> Link 1 <input checked="" type="checkbox"/> Net 2 <input checked="" type="checkbox"/> Link 2
Safety_Test_5590	
Link 2 - Down	
NET 2 - Dual-IP 192.168.2.1	
Link 1 - 1Gb/FULL	
NET 1 - Dual-IP 192.168.1.20	
No Safety Signature	

4-Character Display Messages

NET 1 - Dual-IP 192.168.1.20
No Safety Signature

Linear/DLR Mode

The screenshot shows the Rockwell Automation web interface for a ControlLogix 5590 controller in Linear/DLR Mode. The browser address is 192.168.1.18/index.html. The left sidebar shows a navigation tree with 'Diagnostics' expanded to 'Ethernet Port 1/2'. The main content area displays the following information:

General Information		Resources
Device Name	ControlLogix 5590 Controller	Visit AB.com for additional information
Project Name	Safety_Test_5590	
Device Description		Contacts
Device Location		
Product Revision	38.011	
Firmware Version Date	Aug 21 2025, 19:25:57	
Serial Number	0167A672	
Uptime	04h:04m:31s	
Port 1/2 Ethernet Address (MAC)	08-61:95:E8:93:97	
Port 1/2 IP Address	192.168.1.18	

Controller Diagnostics	
Keyswitch Position	Remote
Controller Mode	Program
Change Detection Audit Value	16#2C5F_598E_CAA8_28C0
I/O Forces	Disabled - None Installed
SFC Forces	Disabled - None Installed

Safety Controller Diagnostics	
Safety Signature	Non-existing
Safety Locked Status	Unlocked
Safety Status	SIL-3 Safety Task OK

Status Indicators	
Controller Status	<input type="checkbox"/> Run <input type="checkbox"/> Force <input type="checkbox"/> SD <input type="checkbox"/> Mod
EtherNet/IP Status	<input checked="" type="checkbox"/> Net 1 <input type="checkbox"/> Link 1 <input checked="" type="checkbox"/> Net 2 <input type="checkbox"/> Link 2
Safety_Test_5590	
Link 2 - Down	
Link 1 - 1Gb/FULL	
NET 1/2 - Linear/DLR 192.168.1.18	

4-Character Display Messages

NET 1/2 - Linear/DLR 192.168.1.18

Seconds Between Refresh: Disable Refresh with 0.

Faults Web Page

The Faults page shows if any major or minor faults exist. This page is the same for 5580 controllers and 5590 controllers.

For 5590 controllers, the page is the same regardless of which EtherNet/IP™ mode the controller is using.

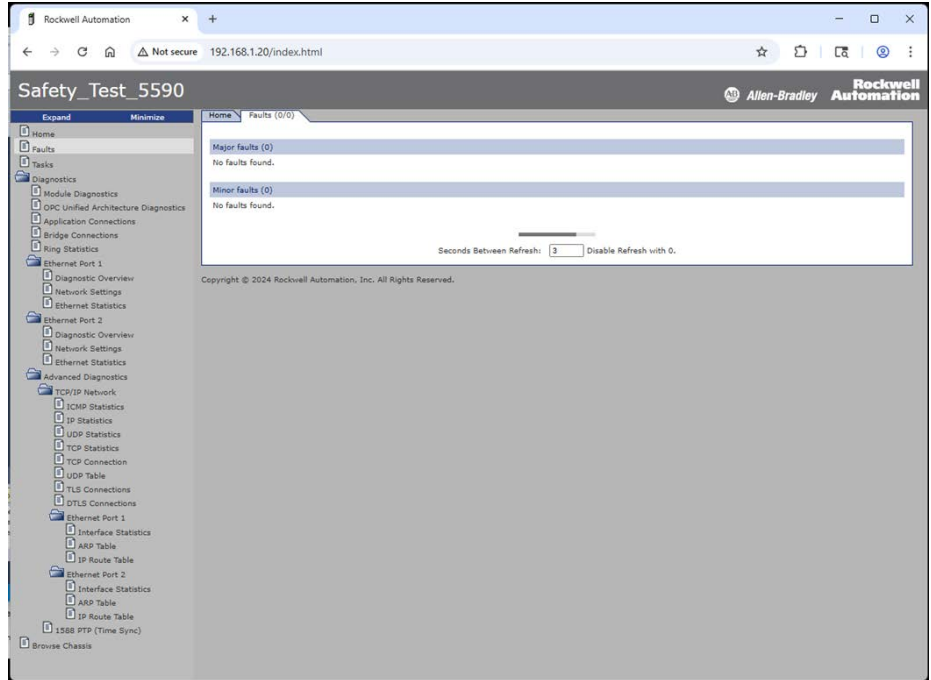

Tasks Web Page

On the Tasks web page, the pie chart shows the percentage of the control core's CPU consumed by the tasks that are on that core. The gauges show the CPU utilization of the control and communications cores. The table shows the tasks that are running on the Control core (all system tasks are summarized as one task).

This page is the same for 5580 controllers and 5590 controllers.

With 5590 controllers, the page is the same regardless of which EtherNet/IP mode the controller is using.

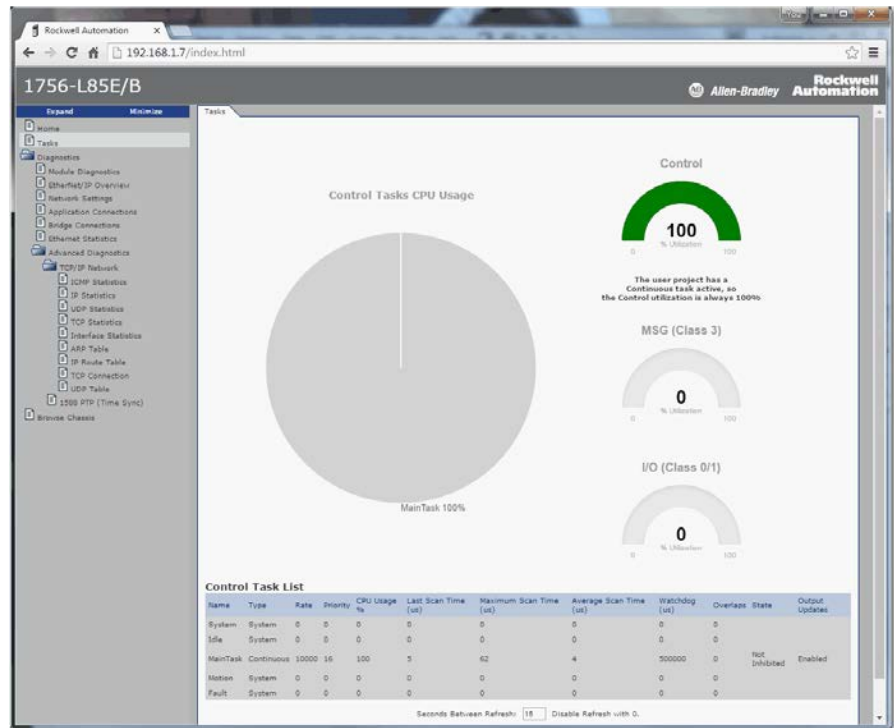

Diagnostics Web Pages

The Diagnostics web pages use a series of tabs to provide information about the following:

- Module Diagnostics
- EtherNet/IP™ Overview
- Network Settings
- Application Connections
- Bridge Connections
- Ethernet Statistics



The 5590 controllers have a few more fields. For example the I/O and Prod/Cons Packets Per Second (All Ports) is on the 5590 controllers' page but not the 5580 controllers' page.

5580 Controllers



5590 Controllers

The page is the same regardless of which EtherNet/IP mode the controller is using.

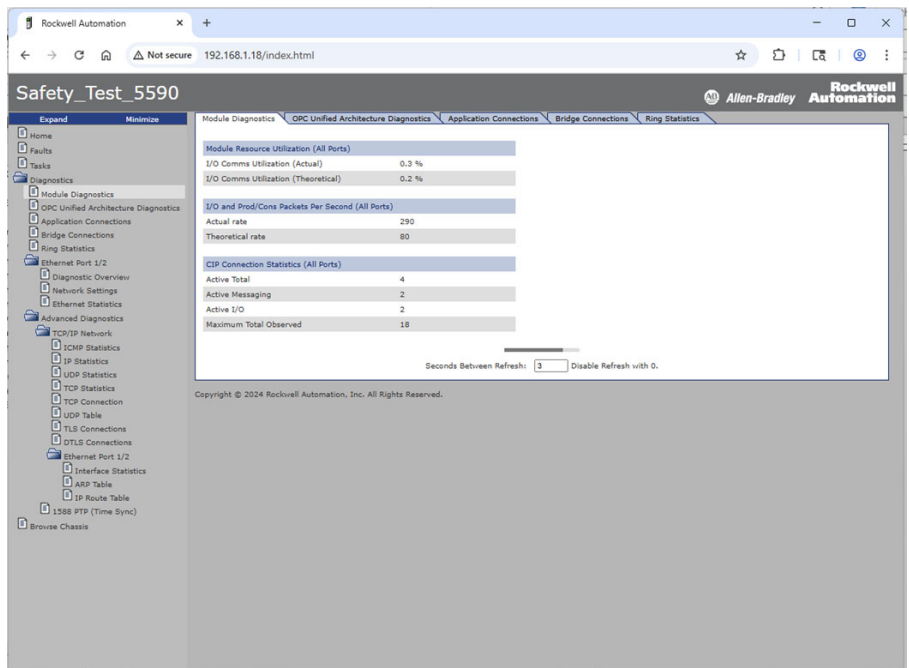

Ethernet Port Web Page - 5590 Controllers Only

This page shows Ethernet port information.

Dual-IP Mode

The screenshot shows the 'Ethernet Statistics' page for a controller in Dual-IP Mode. The left sidebar contains a navigation tree with 'Ethernet Port 1' selected. The main content area displays statistics for two Ethernet ports.

TCP Connections (Ethernet/IP Port)		I/O and Prod/Cons Packets Per Second (Ethernet/IP Port)	
Active	0	Total	0
Maximum Observed	32	Sent	0
Guaranteed	16	Received	0
Maximum Allowed	384	I/O and Prod/Cons Packet Counts (Ethernet/IP Port)	
Total Pool Size	1000	Total	0
HMI/MSG Unconnected (Ethernet/IP Port)		Sent	0
Sent Packets Per Second	0	Received	0
Received Packets Per Second	0	Rejected	0
Sent Packet Count	64	Missed	0
Received Packet Count	64	Multicast Producers (Ethernet/IP Port)	
HMI/MSG Connected (Ethernet/IP Port)		Active	0
Sent Packets Per Second	0	Maximum Observed	0
Received Packets Per Second	0	Maximum Supported	32
Sent Bytes Per Second	0	Base Address	239.192.3.96
Received Bytes Per Second	0		
Sent Packet Count	0		
Received Packet Count	0		

Seconds Between Refresh: 3 Disable Refresh with 0.

Copyright © 2015 Rockwell Automation, Inc. All Rights Reserved.

Linear/DLR Mode

The screenshot shows the 'Ethernet Statistics' page for a controller in Linear/DLR Mode. The left sidebar contains a navigation tree with 'Ethernet Port 1/2' selected. The main content area displays statistics for two Ethernet ports.

TCP Connections (Ethernet/IP Port)		HMI/MSG Connected (Ethernet/IP Port)	
Active	1	Sent Packets Per Second	3
Maximum Observed	34	Received Packets Per Second	3
Guaranteed	16	Sent Bytes Per Second	831
Maximum Allowed	1000	Received Bytes Per Second	532
Total Pool Size	1000	Sent Packet Count	12017
HMI/MSG Unconnected (Ethernet/IP Port)		Received Packet Count	12017
Sent Packets Per Second	0	I/O and Prod/Cons Packets Per Second (Ethernet/IP Port)	
Received Packets Per Second	0	Total	0
Sent Packet Count	748	Sent	0
Received Packet Count	748	Received	0
		Rejected	0
		Missed	0
		Multicast Producers (Ethernet/IP Port)	
		Active	0
		Maximum Observed	0
		Maximum Supported	32
		Base Address	239.192.3.32

Seconds Between Refresh: 3 Disable Refresh with 0.

Copyright © 2024 Rockwell Automation, Inc. All Rights Reserved.

Advanced Diagnostics Web Pages

The Advanced Diagnostics web pages provide information about the following.

- TCP/IP information
- 1588 PTP (Time Sync) information



The 5590 controllers have more tabs on the left-side navigation bar. For example the TLS Connections is on the 5590 controllers' page but not the 5580 controllers' page.

5580 Controllers

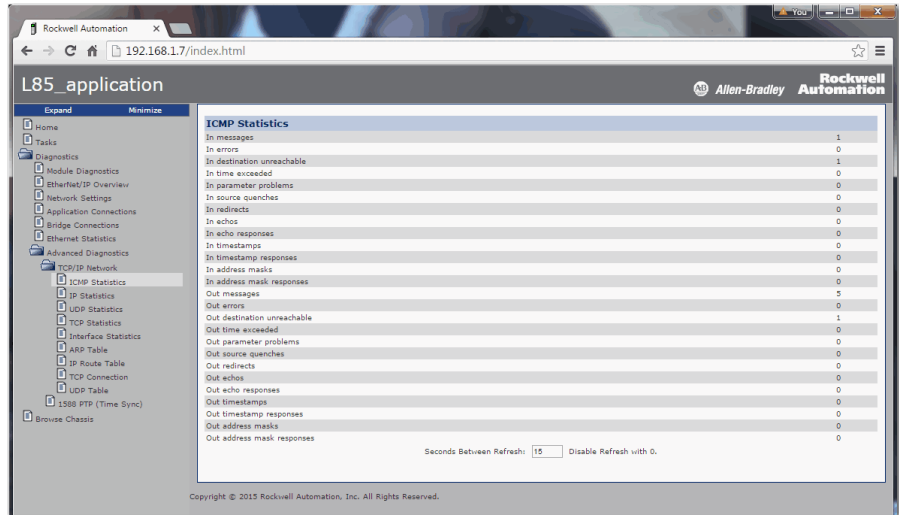

5590 Controllers

The page is the same regardless of which EtherNet/IP mode the controller is using.

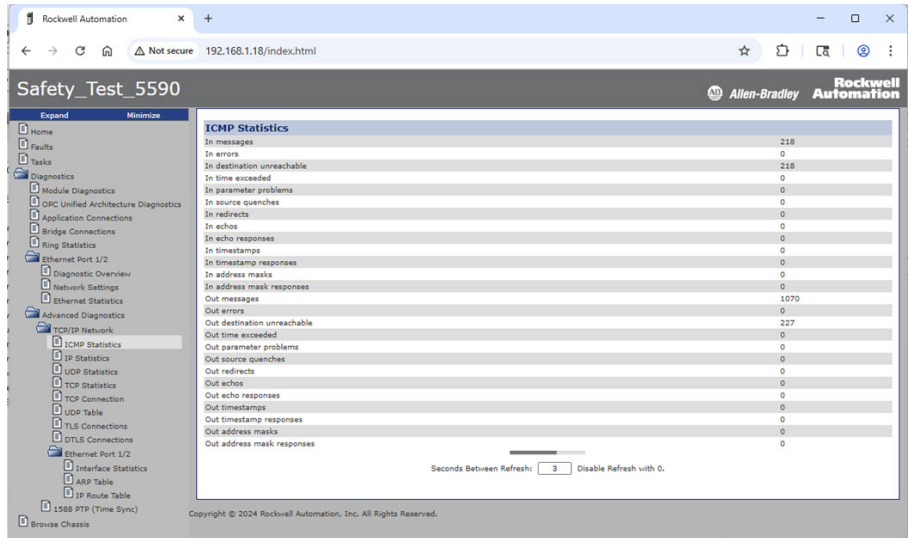

Advanced Diagnostics - Ethernet Ports Web Pages - 5590 Controllers Only

The Advanced Diagnostics web pages provide information about the following:

The page is the same regardless of which EtherNet/IP mode the controller is using.

The screenshot shows the 'Interface Statistics' page for an Ethernet port. The page title is 'Safety_Test_5590'. The left navigation menu includes options like Home, Faults, Tasks, Diagnostics, and Ethernet Port 1/2. The main content area displays the following statistics:

Interface Statistics	
Description	Dem0Com0
MTU	1500
Bandwidth	1000000000
MAC address	08:61:95:68:93:97
In bytes	4433328
In unicast packets	26455
In non-unicast packets	251
In discards	0
In packet drops	0
In errors	0
In unknown protocols	0
Out octets	8712620
Out unicast packets	37561
Out nonunicast packets	3353
Out discards	0
Out errors	0
Outset packet queue length	0

At the bottom of the statistics table, there is a refresh control: 'Seconds Between Refresh: 3 Disable Refresh with 0.'

Copyright © 2024 Rockwell Automation, Inc. All Rights Reserved.

Browse Chassis Web Page

Browse Chassis lets you view module information, backplane statistics, and connection statistics for modules in the local chassis. This page is the same for 5580 controllers and 5590 controllers.

Click on the catalog number to see more information for that device.

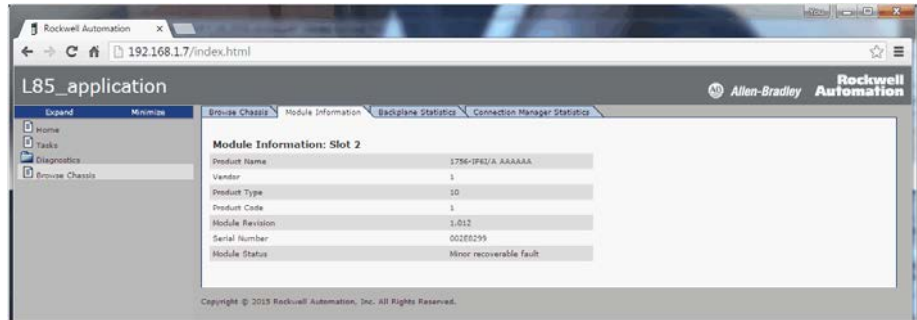

Diagnostics and Status Indicators with CompactLogix Systems

This chapter features these controllers, and where applicable, the controllers are known as:

Controller Family	Includes these controllers
5380 controllers	CompactLogix® 5380, Compact GuardLogix® 5380 SIL 2, and Compact GuardLogix 5380 SIL 3 controllers
5370 controllers	CompactLogix 5370 and Compact GuardLogix 5370 controllers

For information on replacing CompactLogix 1769-L3 or CompactLogix 1768-L4 controllers, see [Replacement Considerations for 1768-L4 and 1769-L3 Controllers on page 205](#).

The status indicators on the 5380 controllers differ from status indicators on the 5370 controllers. 5380 controllers provide the following:

- 4-character display that shows messages to provide information about the controller, for example, the firmware revision
- MOD Power and SA Power status indicators

Figure 33 - Status Display and Indicator

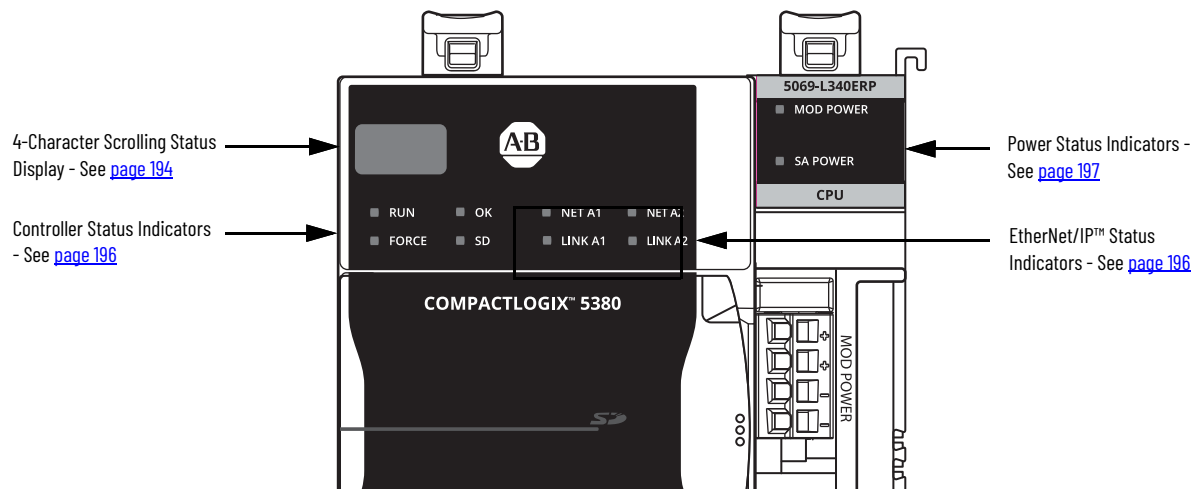

You can diagnose and troubleshoot the 5380 Controllers with:

- [Controller Status Display and Indicators on page 194](#)
- [Controller Web Pages on page 198](#)

Controller Status Display and Indicators

The 5380 controllers provide the following:

- [4-Character Display](#)
- [Controller Status Indicators](#)
- [EtherNet/IP Status Indicators](#)
- [Power Status Indicators](#)

4-Character Display

The 5380 controllers use a 4-character display that scrolls messages about the controller. The display provides easy access to information that you can use to monitor or troubleshoot the controller operation

IMPORTANT The 5370 controllers do not have a 4-character display.

The 4-character display messages provide information about the following:

- General controller status
- General fault information, if a fault has occurred on the controller
- Major fault information, if a major fault has occurred on the controller
- I/O fault codes, if an I/O fault has occurred in the 5380 system

This table lists the general status messages that can scroll across the display. For information about more detailed controller conditions, see the CompactLogix 5380 and Compact GuardLogix 5380 Controllers User Manual, publication [5069-UM001](#).

Table 18 - General Status Messages

Message	Interpretation
No message is indicated	The controller is Off. <ul style="list-style-type: none"> • Check the MOD power status indicator to see if power is applied to the system. • Check the OK indicator to determine if the controller is powered and to determine the state of the controller.
TEST	The controller is conducting power-up tests.
CHRG	The embedded energy storage circuit is charging.
PASS	Power-up tests have completed successfully.
Saving...Do Not Remove SD Card	The controller is about to save an image to the SD card.
SAVE	A project is being saved to the SD card. Let the save operation complete before you take the following actions: <ul style="list-style-type: none"> • Remove the SD card. • Disconnect the power. IMPORTANT: Do not remove the SD card while the controller is saving to the SD card. Let the save complete without interruption. If you interrupt the save, data corruption or loss can occur.
One of the following: <ul style="list-style-type: none"> • LOAD • Loading . . . Do Not Remove SD Card 	A project is being loaded from the SD card. Let the load operation complete before doing the following: <ul style="list-style-type: none"> • Remove the SD card • Disconnect the power IMPORTANT: Do not remove the SD card while the controller is loading from the SD card. Let the load complete without interruption. If you interrupt the load, data corruption or loss can occur.
UPDT	A firmware update is being conducted from the SD card upon powerup. If you do not want the firmware to update upon powerup, change the Load Image property of the controller.
Rev XX.xxx	The firmware major and minor revision of the controller.
5069-L3xxx	The controller catalog number and series.
Link Ax Down	Message appears when an Ethernet port does not have a network connection. Message scrolls continuously during operation. IMPORTANT: When the controller operates in Dual-IP mode, this information is provided for each link, that is, Link A1 and Link A2. The link name appears before the information.
Link Ax Disabled	Message appears when you have disabled an Ethernet port. Message scrolls continuously during operation. IMPORTANT: When the controller operates in Dual-IP mode, this information is provided for each link, that is, Link A1 and Link A2. The link name appears before the information.
DHCP- 00:00:XX:XX:XX:XX	Message appears when the controller is set for DHCP, but not configured on a network. The message shows the MAC address of the controller. Message scrolls continuously during operation if no IP address is set. IMPORTANT: When the controller operates in Dual-IP mode, this information is provided for each port, that is, Port A1 and Port A2. The port name appears before the information.

Table 18 - General Status Messages (Continued)

Message	Interpretation
Ethernet Port Rate/Duplex State	The current port rate and duplex state when an Ethernet port has a connection. Message scrolls continuously during operation. IMPORTANT: When the controller operates in Dual-IP mode, this information is provided for each link, that is, Link A1 and Link A2. The link name appears before the information.
IP Address	The IP address of the controller. Appears on powerup and scrolls continuously during operation. If the IP address is not yet set, the MAC address appears. IMPORTANT: When the controller operates in Dual-IP mode, this information is provided for each port, that is, Port A1 and Port A2. The port name appears before the information.
Duplicate IP - 00:00:XX:XX:XX:XX	Message appears when the controller detects a device with the same IP Address on the network. The message shows the MAC address of the device with the duplicate IP Address. Message scrolls continuously during operation. IMPORTANT: When the controller operates in Dual-IP mode, this information is provided for each port, that is, Port A1 and Port A2. The port name appears before the information.
DHCP-Address Lost	The controller has communicated with the DHCP server to renew the IP address. The server either did not reply or did not renew the IP address. The controller continues to operate, but with no Ethernet connectivity out of this port. IMPORTANT: When the controller operates in Dual-IP mode, this information is provided for each port, that is, Port A1 and Port A2. The port name appears before the information.
IP Address/Mask/Gateway/DNS Invalid	The DHCP server responded with an unusable combination. IMPORTANT: When the controller operates in Dual-IP mode, this information is provided for each port, that is, Port A1 and Port A2. The port name appears before the information.
IP Address Invalid	The IP address that is used in the port configuration is not valid. IMPORTANT: When the controller operates in Dual-IP mode, this information is provided for each port, that is, Port A1 and Port A2. The port name appears before the information.
Mask Invalid	The Subnet/Network Mask used in the port configuration is not valid. IMPORTANT: When the controller operates in Dual-IP mode, this information is provided for each port, that is, Port A1 and Port A2. The port name appears before the information.
Gateway Invalid	The Gateway address that is used in the port IP configuration is not valid. IMPORTANT: When the controller operates in Dual-IP mode, this information is provided for each port, that is, Port A1 and Port A2. The port name appears before the information.
DNS Invalid	The DNS used in the port IP configuration is not valid.
No Project	No project is loaded on the controller. To load a project, complete one of the following tasks: <ul style="list-style-type: none"> • Use the Studio 5000 Logix Designer® application to download the project to the controller • Use a memory card to load a project to the controller
Project Name	The name of the project that is loaded on the controller.
BUSY	The I/O modules that are associated with the controller are not yet fully powered. Let powerup and I/O module self-testing complete.
Corrupt Certificate Received	The security certificate that is associated with the firmware is corrupted. Go to http://www.rockwellautomation.com/support/ and download the firmware revision to which you are trying to update. Replace the firmware revision that you have previously installed with that posted on the Technical Support website.
Corrupt Image Received	The firmware file is corrupted. Go to http://www.rockwellautomation.com/support/ and download the firmware revision to which you are trying to update. Replace the firmware revision that you have previously installed with that posted on the Technical Support website.
Backup Energy HW Failure - Save Project	A failure with the embedded storage module has occurred. If power is lost to the controller, the controller cannot save the program. If you see this message, save your program to the SD card before you remove power and replace the controller.
Backup Energy Low - Save Project	The embedded storage module does not have sufficient energy to enable the controller to save the program if power is lost to the controller. If you see this message, save your program to the SD card before you remove power and replace the controller.
Flash in Progress	A firmware update that is initiated via ControlFLASH™, ControlFLASH Plus™, or AutoFlash utilities is in progress. Let the firmware update complete without interruption.
Firmware Installation Required	The controller currently uses boot firmware, that is, revision 1.xxx, and requires a firmware update.
SD Card Locked	An SD card that is locked is installed.

Controller Status Indicators

The controller status indicators on the 5380 controllers are the same as the controller status indicators on the 5370 controllers. The controller status indicators include the following:

- RUN
- FORCE
- OK
- SD

Controller status indicators function the same on 5380 and 5370 controllers.

EtherNet/IP Status Indicators

The 5380 and 5370 controllers provide status indicators for EtherNet/IP™ network status and EtherNet/IP link status.

EtherNet/IP Network Status

The EtherNet/IP network status indicators on the 5380 controllers and the 5370 controllers differ in appearance.

- 5380 controllers have a separate EtherNet/IP network status indicator for each EtherNet/IP port on the controller. The indicators are NET A1 and NET A2.

IMPORTANT The NET A1 and NET A2 indicators are used when the controller operates in Dual-IP mode. Only the NET A1 indicator is used when the controller operates in DLR/Linear mode.

- 5370 controllers have one EtherNet/IP network status indicator. The indicator is NS.

The EtherNet/IP network status indicators function the same way on the 5380 controllers as the 5370 controllers.

For example, if the 5380 controller NET A1 status indicator is steady green, the controller has an IP address and at least one connection is established. The same is true for the 5370 controller NS status indicator.

EtherNet/IP Link Status

The EtherNet/IP link status indicators on the 5380 controllers are slightly different from the EtherNet/IP link status indicators on the 5370 controller in appearance.

On the 5380 controller, the EtherNet/IP link status indicators are labeled LINK A1 and LINK A2. The same indicators on the 5370 controllers are labeled LINK 1 and LINK 2.

The EtherNet/IP link status indicators function the same way on the 5380 controllers as the 5370 controllers.

For example, if the 5380 controller LINK A1 or the 5370 controller LINK 1 status indicator is flashing green, an EtherNet/IP link exists and there is activity.

Power Status Indicators

The 5380 controllers use power status indicators show the status of MOD power and SA power.

MOD Power Indicator

[Table 19](#) describes the MOD Power indicator on a 5380 controller.

Table 19 - MOD Power Indicator

State	Description
Off	Module Power is not present
Steady green	Module Power is present ⁽¹⁾

(1) Although unlikely, it is possible that there is enough Module Power present for the indicator to turn steady green but the power is not valid. Valid power is 18...32V DC to operate a 5380 system. If the system does not power up and operate successfully, Module Power can be invalid. If Module Power is invalid, we recommend that you make sure that the external power supply is working correctly, properly sized for your application and that all wiring is correct.

SA Power Indicator

[Table 20](#) describes the SA Power indicator on a 5380 controller.

Table 20 - SA Power Indicator

State	Description
Off	One of the following: <ul style="list-style-type: none"> • Sensor Actuator Power is not present • Status of Sensor Actuator power is unknown
Steady green	Sensor Actuator Power is present ⁽¹⁾

(1) Although unlikely, it is possible that there is enough Sensor/Actuator Power present for the indicator to turn steady green but the power is not valid. Valid power is 18...32V DC in applications that require DC voltage and 18...240V AC in applications that require AC voltage. If Sensor/Actuator Power is invalid, we recommend that you make sure that the external power supply is working correctly, properly sized for your application and that all wiring is correct.

Controller Web Pages

The 5380 controllers and 5370 controllers provide diagnostic web pages that track controller performance, network performance, and backplane performance.

- IMPORTANT** With the Studio 5000 Logix Designer application version 33.00.00 and later, controller web pages are disabled by default.
- To enable the controller web pages, select the checkbox on the Logix Designer Controller Properties Security tab.

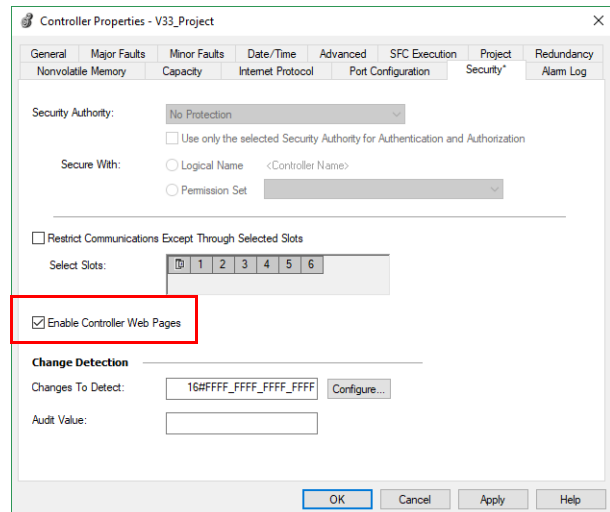

Differences Between 5380 and 5370 Controllers

The primary difference between the 5380 and 5370 controller web pages is the organization of content on the browser.

For example, the Diagnostic Overview tab is in the Ethernet Port A1/A2 folder for 5380 controllers. The same tab is in the Diagnostics folder for 5370 controllers.

The new Tasks web page shows the control tasks that are running on the control core, usage of the control core's CPU consumed by the tasks that are on that core, and the CPU utilization of the control and communications cores.

EtherNet/IP Mode Affect on 5380 Controller Web Pages

The 5380 controller web pages look different and provide different information based on the EtherNet/IP mode that is used.

For example, consider the following:

- When the controller operates in Linear/DLR mode, the left-side navigation bar displays an Ethernet Port A1/A2 folder with three tabs.
- There is one Ethernet Port web page for both ports, and the controller web pages provide one set of Ethernet data.
- When the controller operates in Dual-IP mode, the left-side navigation bar displays an Ethernet Port A1 folder and an Ethernet Port A2 folder. Each folder has three tabs.
- There is an Ethernet Port web page for each port. The controller web pages provide one set of Ethernet data for port A1 and another set of Ethernet data for port A2.

To access the diagnostic web pages, follow these steps.

- Open your web browser.
- In the Address field, type the IP address of the controller and press Enter.
- To access the information that you need, use the links in the left-side navigation bar.

Home Web Page

The Home web page provides device information and controller status.

Linear/DLR Mode

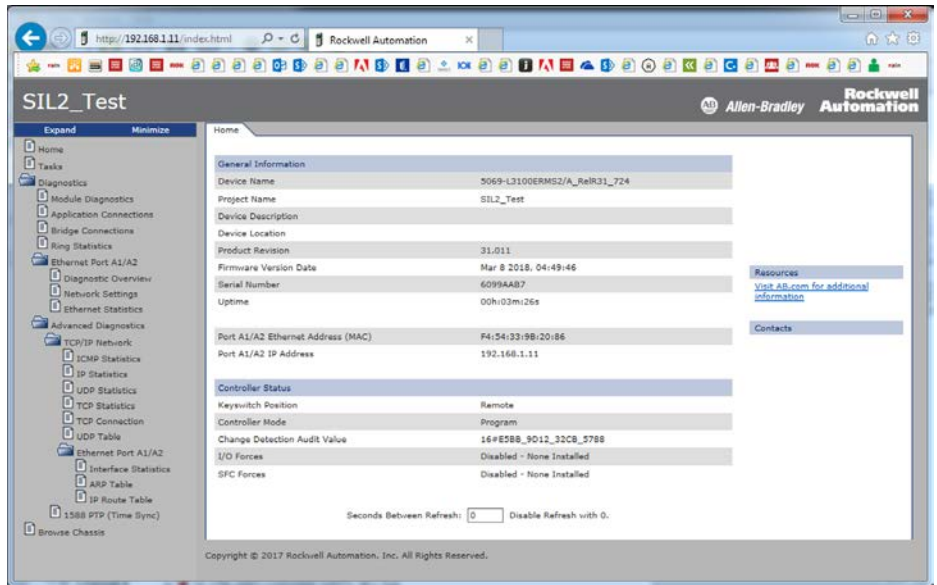

Dual-IP Mode

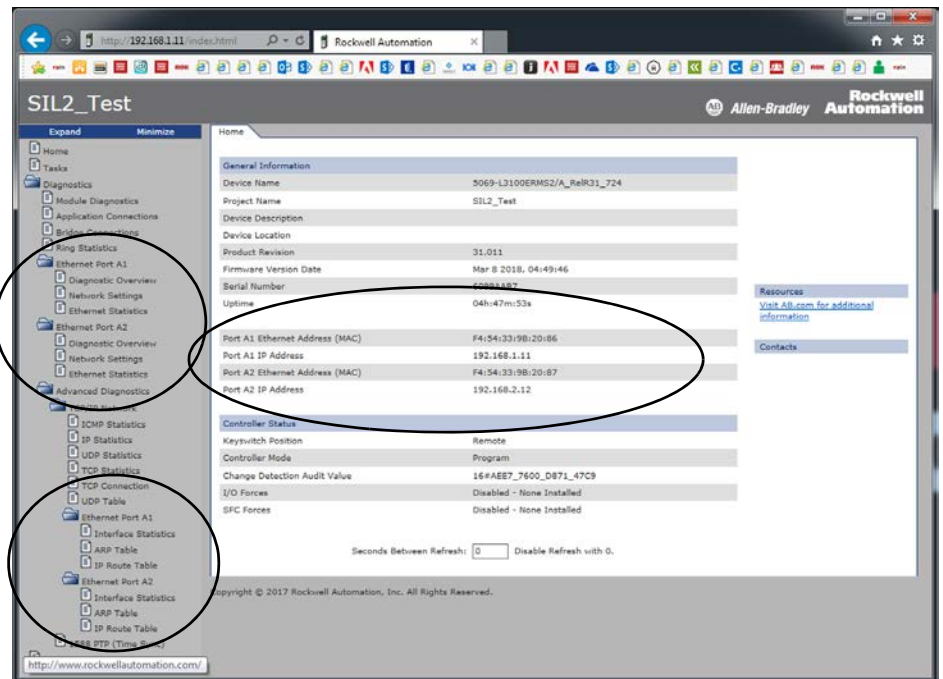

Tasks Web Page

IMPORTANT This web page is not available with the 5370 controllers.

On the Tasks web page, the pie chart shows the percentage of the control core's CPU consumed by the tasks that are on that core. The gauges show the CPU utilization of the control and communications cores.

The table shows the tasks that are running on the Control core (all system tasks are summarized as one task).

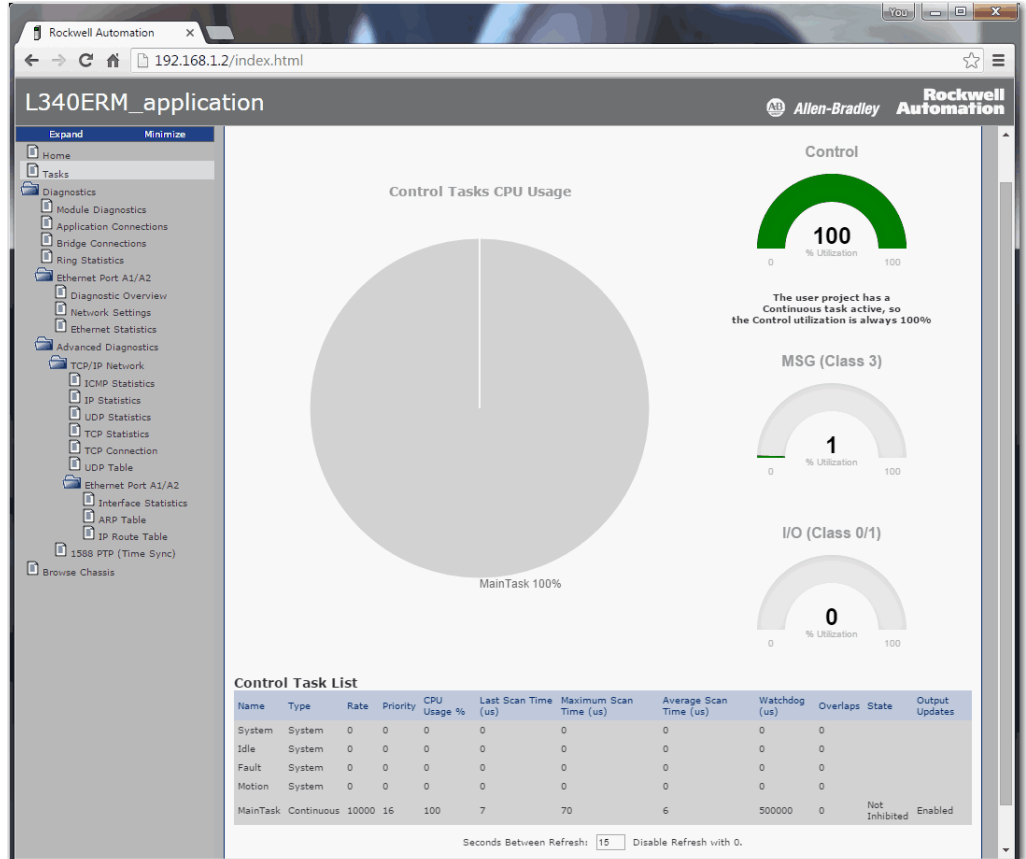

Diagnostics Web Pages

The Diagnostics web pages use a series of tabs to provide information about the following:

- Module Diagnostics
- Application Connections
- Bridge Connections
- Ring Statistics

The screenshot displays the Rockwell Automation web interface for an L340ERM application. The browser address bar shows the URL 192.168.1.2/index.html. The page title is "L340ERM_application" and the Rockwell Automation logo is visible in the top right corner. The interface features a navigation menu on the left with options like Home, tasks, diagnostics, and various network-related settings. The main content area is divided into tabs: Module Diagnostics, Application Connections, Bridge Connections, and Ring Statistics. The "Module Diagnostics" tab is active, showing the following data:

Module Resource Utilization (All Ports)	
I/O Comms Utilization (Actual)	0.5 %
I/O Comms Utilization (Theoretical)	0.5 %

CIP Connection Statistics (All Ports)	
Active Total	6
Active Messaging	1
Active I/O	5
Maximum-Total Observed	7

Below the tables, there is a "Seconds Between Refresh" input field set to 15 and a "Disable Refresh with 0" checkbox. The footer of the page contains the copyright notice: "Copyright © 2015 Rockwell Automation, Inc. All Rights Reserved."

Ethernet Port A1/A2 Web Pages

The Ethernet Port A1/A2 web pages use a series of tabs to provide information about the following:

- Diagnostic Overview
- Network Settings
- Ethernet Statistics

Linear/DLR Mode

The screenshot shows the 'Ethernet Statistics' tab for Ethernet Port A1/A2. The data is as follows:

TCP Connections (Ethernet/IP Port)		HMI/MSG Connected (Ethernet/IP Port)	
Active	2	Sent Packets Per Second	3
Maximum Observed	2	Received Packets Per Second	3
Guaranteed	5	Sent Bytes Per Second	1500
Maximum Allowed	512	Received Bytes Per Second	598
Total Pool Size	512	Sent Packet Count	9197
		Received Packet Count	9197

HMI/MSG Unconnected (Ethernet/IP Port)		I/O and Prod/Cons Packets Per Second (Ethernet/IP Port)	
Sent Packets Per Second	0	Total	428
Received Packets Per Second	0	Sent	214
Sent Packet Count	122	Received	214
Received Packet Count	122		

I/O and Prod/Cons Packet Counts (Ethernet/IP Port)	
Total	963537
Sent	481772
Received	481765
Rejected	0
Missed	0

Multicast Producers (Ethernet/IP Port)	
Active	0
Maximum Observed	0
Maximum Supported	32
Base Address	239.192.1.32

Seconds Between Refresh: 15 Disable Refresh with 0.

Dual-IP Mode

The screenshot shows the 'Ethernet Statistics' tab for Ethernet Port A1 and Ethernet Port A2. The data is as follows:

TCP Connections (Ethernet/IP Port)		HMI/MSG Connected (Ethernet/IP Port)	
Active	0	Sent Packets Per Second	0
Maximum Observed	1	Received Packets Per Second	0
Guaranteed	16	Sent Bytes Per Second	0
Maximum Allowed	496	Received Bytes Per Second	0
Total Pool Size	512	Sent Packet Count	0
		Received Packet Count	0

HMI/MSG Unconnected (Ethernet/IP Port)		I/O and Prod/Cons Packets Per Second (Ethernet/IP Port)	
Sent Packets Per Second	0	Total	0
Received Packets Per Second	0	Sent	0
Sent Packet Count	9	Received	0
Received Packet Count	9		

I/O and Prod/Cons Packet Counts (Ethernet/IP Port)	
Total	0
Sent	0
Received	0
Rejected	0
Missed	0

Multicast Producers (Ethernet/IP Port)	
Active	0
Maximum Observed	0
Maximum Supported	32
Base Address	239.192.1.32

Seconds Between Refresh: 15 Disable Refresh with 0.

Copyright © 2015 Rockwell Automation, Inc. All Rights Reserved.

Advanced Diagnostics Web Pages

The Advanced Diagnostics web pages provide information about the following:

- TCP/IP Network - Provide information about the following:
 - ICMP Statistics
 - IP Statistics
 - UDP Statistics
 - TCP Statistics
 - TCP Connection
 - UDP Table
- Ethernet Port A1/A2- Provide information about the following:
 - Interface Statistics
 - ARP Table
 - IP Route Table
- 1588 PTP (Time Sync)

Linear/DLR Mode

ICMP Statistics	
In messages	1
In errors	0
In destination unreachable	1
In time exceeded	0
In parameter problems	0
In source quenches	0
In redirects	0
In echos	0
In echo responses	0
In timestamps	0
In timestamp responses	0
In address masks	0
In address mask responses	0
Out messages	3
Out errors	0
Out destination unreachable	1
Out time exceeded	0
Out parameter problems	0
Out source quenches	0
Out redirects	0
Out echos	0
Out echo responses	0
Out timestamps	0
Out timestamp responses	0
Out address masks	0
Out address mask responses	0

Seconds Between Refresh: Disable Refresh with 0.

Copyright © 2015 Rockwell Automation, Inc. All Rights Reserved.

Dual-IP Mode

ICMP Statistics	
In messages	1
In errors	0
In destination unreachable	1
In time exceeded	0
In parameter problems	0
In source quenches	0
In redirects	0
In echos	0
In echo responses	0
In timestamps	0
In timestamp responses	0
In address masks	0
In address mask responses	0
Out messages	3
Out errors	0
Out destination unreachable	1
Out time exceeded	0
Out parameter problems	0
Out source quenches	0
Out redirects	0
Out echos	0
Out echo responses	0
Out timestamps	0
Out timestamp responses	0
Out address masks	0
Out address mask responses	0

Seconds Between Refresh: Disable Refresh with 0.

Copyright © 2015 Rockwell Automation, Inc. All Rights Reserved.

Browse Chassis Web Page

The Browse Chassis provides information about the devices in the system. You can click the link for each catalog number to access more information about that device.

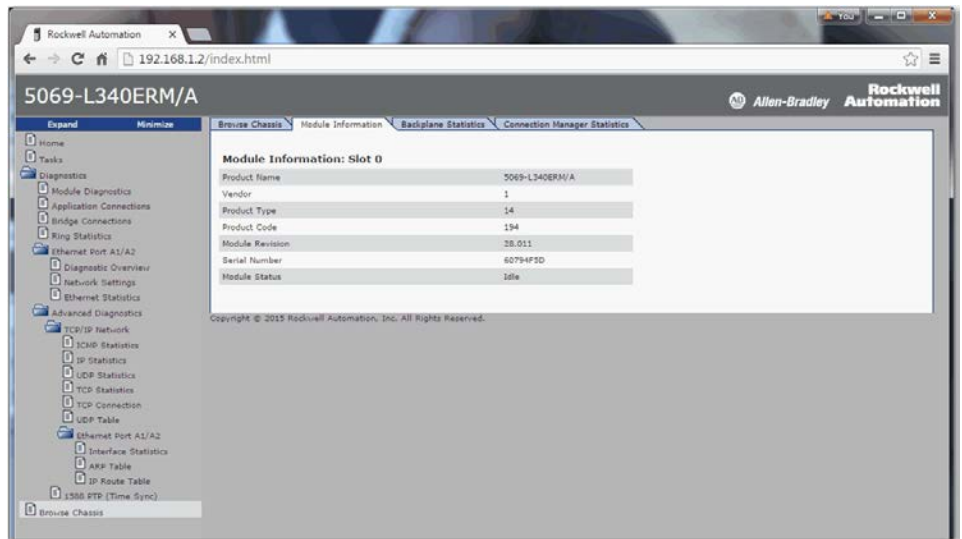
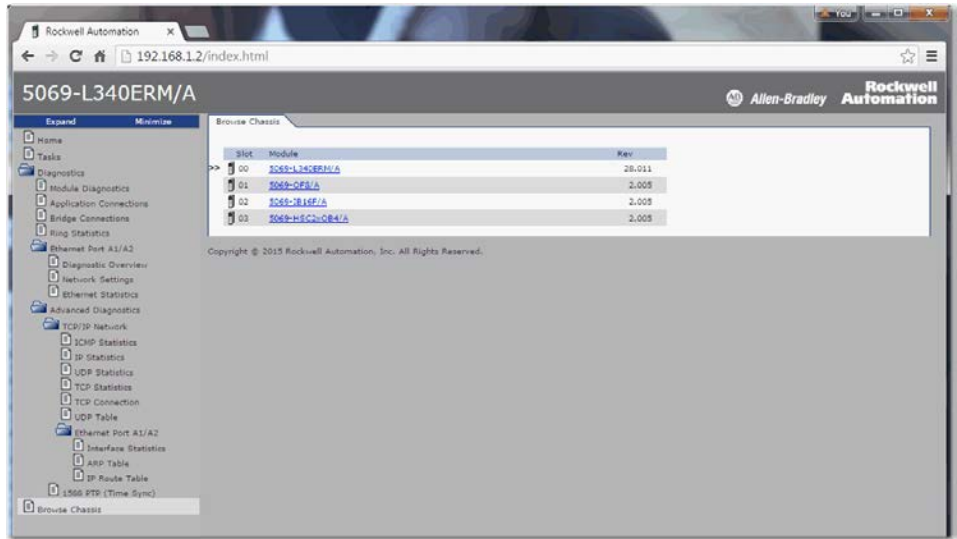

Replacement Considerations for 1768-L4 and 1769-L3 Controllers

This chapter features these controllers, and where applicable, the controllers are known as:

Controller Family	Includes These Controllers
5380 controllers	CompactLogix™ 5380 and Compact GuardLogix® 5380 controllers
1769-L3 controllers	CompactLogix 1769-L31, 1769-L32C, 1769-L32E, 1769-L32EK, 1769-L35CR, 1769-L35E controllers
1768-L4 controllers	CompactLogix L4 and Compact GuardLogix L4 controllers

The content in the previous chapters that describes features and functions of CompactLogix 5380 and Compact GuardLogix 5380 controllers applies when migrating. This appendix provides specific considerations for 1769-L3 and 1768-L4 controllers.

Replacing a 1769-L3 and 1768-L4 controller with a 5380 controller is an engineering replacement. This requires engineering changes to existing applications. Form, fit, or function have changed and are NOT backward-compatible, requiring engineering effort that can include additional software/hardware tools and products or architectural modifications.

Minimum Requirements

The controllers have these minimum requirements.

CompactLogix Controllers Minimum Requirements

Requirement, Minimum	CompactLogix 1769-L3 controllers	CompactLogix 1768-L4 Controllers	CompactLogix 5380 Controllers
Programming Software	Studio 5000 Automation Engineering & Design Environment®, Versions 16.00.00 ...20.00.00	Studio 5000 Automation Engineering & Design Environment, Versions 16.00.00 ...20.00.00	Studio 5000 Logix Designer® Application, Version 28.00.00 or later ⁽¹⁾

(1) Most CompactLogix 5380 controllers are first available in version 29.00.00. Also, you must use version 29 or later to use Dual-IP mode with CompactLogix 5380 controllers.

Compact GuardLogix Controllers Minimum Requirements

Requirement, Minimum	Compact GuardLogix 1768-L4 Controllers	Compact GuardLogix 5380 Controllers
Programming Software	Studio 5000 Automation Engineering & Design Environment, Versions 18.00.00 ...20.00.00	Studio 5000 Logix Designer Application, Version 31.00.00 or later

Product Comparison

The 5380 controllers operate similar to the 1769-L3 and 1768-L4 controllers, with these differences.

CompactLogix Controllers Product Comparison

Table 21 - Technical Specification

Attribute	CompactLogix 1769-L3 Controller	CompactLogix 1768-L4 Controller	CompactLogix 5380 Controller
Memory	1769-L31: 512 Kbytes 1769-L32C, 1769-L32E: 750 Kbytes 1769-L35CR, 1769-L35E: 1.5 Mbytes	1768-L43: 2 MB 1768-L45: 3 MB	5069-L306ER, 5069-L306ERM: 0.6 MB 5069-L310ER, 5069-L310ER-NSE, 5069-L310ERM: 1 MB 5069-L320ER, 5069-L320ERM: 2 MB 5069-L330ER, 5069-L330ERM: 3 MB 5069-L340ER, 5069-L340ERM: 4 MB 5069-L350ERM: 5 MB 5069-L380ERM: 8 MB 5069-L3100ERM: 10 MB
Local I/O modules supported	1769 Compact I/O™ Number of local I/O modules that are supported varies by controller catalog number	1768 communication modules, 1769 Compact I/O Number of local I/O modules that are supported varies by controller catalog number	Compact 5000™ I/O Standard modules only Number of local I/O modules that are supported varies by controller catalog number
Remote I/O modules supported	<ul style="list-style-type: none"> • 1794 FLEX™ I/O • 1769 Compact I/O™ • 1756 ControlLogix® I/O • 1734 POINT I/O™ • 1732E ArmorBlock® 	<ul style="list-style-type: none"> • 1794 FLEX I/O • 1769 Compact I/O • 1756 ControlLogix I/O • 1734 POINT I/O • 1732E ArmorBlock 	<ul style="list-style-type: none"> • 5094 FLEX 5000® I/O⁽¹⁾ • 5069 Compact 5000® I/O⁽²⁾ • 5034 PointMax™ I/O⁽³⁾ • 5032 ArmorBlock 5000® I/O⁽⁴⁾ • 1794 FLEX I/O • 1769 Compact I/O • 1756 ControlLogix I/O • 1734 POINT I/O • 1732E ArmorBlock
Communication options	1769-L31: Serial 1769-L32C, 1769-L35CR: ControlNet®, Serial 1769-L32E, 1769-L35E: EtherNet/IP™, Serial	1768-CNET: ControlNet 1768-EN2T, 1769-EWEB: EtherNet/IP	Embedded EtherNet/IP port
Unconnected message buffers	3 incoming unconnected buffers. 10 outgoing unconnected buffers. You can increase this to 40 by using a CIP™ Generic message instruction.	No fixed limits, as long as the controller can allocate the buffer it will.	320 - Any combination of outgoing or incoming unconnected messages.
Concurrent cached message instructions in the running state	32, drawn from the 250 total connections supported by the controller.	32, drawn from the 250 total connections supported by the controller.	256 dedicated buffers
HMI and Messaging (Class 3)	Drawn from the 100 total connections supported by the controller.	Drawn from the 250 total connections supported by the controller.	512 dedicated messages (256 incoming messages and 256 outgoing messages)
Integrated motion	Not supported	SERCOS	EtherNet/IP network

Table 21 - Technical Specification

Attribute	CompactLogix 1769-L3 Controller	CompactLogix 1768-L4 Controller	CompactLogix 5380 Controller
Motion axes	Not supported	1768-L43: As many as 4 axes with the use of two SERCOS modules 1768-L45: As many as 8 axes with the use of four SERCOS modules	5380 controllers supports from 2 to 32 axes depending on catalog number. Any combination of these supported axis types: <ul style="list-style-type: none"> • CIP • Consumed • Virtual • Position loop drives As many as 32 Axes/ms when you use the built-in EtherNet/IP port at 1 Gbps. IMPORTANT: Not all CompactLogix 5380 controllers support Integrated Motion over an EtherNet/IP network.
Voltage and current ratings	1769-L31: 330 mA@ 5V DC, 40 mA@ 24V DC 1769-L32C: 650 mA@ 5V DC, 40 mA@ 24V DC 1769-L32E: 660 mA@ 5V DC, 90 mA@ 24V DC 1769-L35CR: 680 mA@ 5V DC, 40 mA@ 24V DC 1769-L35E: 660 mA@ 5V DC, 90 mA@ 24V DC	1768-L43 Backplane current: 1.3 A @ 24V DC 1768 backplane current output: 2.8 A @ 5.2V DC 1769 backplane current output: 2.0 A @ 5.2V DC Total 1768 and 1769 backplane current output: 4.8 A @ 5.2V DC 1768-L45 Backplane current: 2 A @ 24V DC 1768 backplane current output: 5.6 A @ 5.2V DC 1769 backplane current output: 2.0 A @ 5.2V DC Total 1768 and 1769 backplane current output: 7.6 A @ 5.2V DC	MOD Power: 450 mA @ 18...32V DC MOD Power Inrush: 850 mA for 125 ms SA Power: 10 mA @ 0...32V DC 25 mA @ 0...240V AC, 47...63 Hz ATEX/IECEX, 125V AC Max MOD Power (Passthrough) ⁽⁵⁾ : 9.55 A @ 18...32V DC SA Power (Passthrough) ⁽⁶⁾ : 9.95 A @ 0...32V DC 9.975 A @ 0...240V AC, 47...63 Hz ATEX/IECEX, 125V AC Max
Energy storage module	1769-BA Battery	Not applicable. Energy stored in the 1768 power supply maintains controller power long enough to store the program to internal flash memory (not the external CompactFlash card).	Non-removable
Weight, approx	1769-L31: 0.30 kg (0.66 lb) 1769-L32C: 0.32 kg (0.70 lb) 1769-L32E: 0.30 kg (0.66 lb) 1769-L35CR: 0.32 kg (0.70 lb) 1769-L35E: 0.30 kg (0.66 lb)	0.34 kg (0.75 lb)	0.394 kg (.868 lb)
Wire category ⁽⁷⁾	2 - on communication ports	2 - on communication ports	3 - on USB port 1 - on power ports 2 - on Ethernet port

Table 21 - Technical Specification

Attribute	CompactLogix 1769-L3 Controller	CompactLogix 1768-L4 Controller	CompactLogix 5380 Controller
Wire size	1756-CP3 or 1747-CP3, right angle connector to controller, straight to serial port, 3 m	1756-CP3 or 1747-CP3, right angle connector to controller, straight to serial port, 3 m	Ethernet connections: Ethernet Cabling and Installation according to IEC 61918 and IEC 61784-5-2
Removable terminal block	Not Applicable	Not Applicable	Kit 5069-RTB64-SCREW or kit 5069-RTB64-SPRING You must order the kit separately. RTBs do not ship with the controller. 5069-RTB4-SCREW, 5069-RTB6-SCREW connections: 0.5...1.5 mm ² (22...16 AWG) solid or stranded copper wire rated at 105 °C (221 °F), or greater, 3.5 mm (0.14 in.) max diameter including insulation, single wire connection only 5069-RTB4-SPRING, 5069-RTB6-SPRING connections: 0.5...1.5 mm ² (22...16 AWG) solid or stranded copper wire rated at 105 °C (221 °F), or greater, 2.9 mm (0.11 in.) max diameter including insulation, single wire connection only
Reset Button	If press the Channel 0 default communication push button after power is applied to the controller, the controller resets the RS-232 configuration setting to the defaults.	If you access the button after power is applied to the controller, the controller resets the RS-232 configuration setting to the defaults If you access the button while the controller is powering up, the controller clears the user program from controller memory.	A Stage 1 reset clears the application program and memory, but retains the IP address and all object attributes designated as non-volatile. A Stage 1 reset occurs only if the controller contains a user application. A Stage 2 reset returns the controller to out-of box settings, including firmware, and clears all network settings. A Stage 2 reset occurs only if the controller does not contain a user application, and the current controller firmware is not a 1.x revision. For information on how to use the reset button, see the CompactLogix 5380 and Compact GuardLogix 5380 Controllers User Manual, publication 5069-UM001 .

- (1) With Studio 5000 Logix Designer application, version 32.00.00 or later.
- (2) With Studio 5000 Logix Designer application, version 31.00.00 or later.
- (3) With Studio 5000 Logix Designer application, version 36.00.00 or later.
- (4) With Studio 5000 Logix Designer application, version 35.00.00 or later.
- (5) Maximum level of MOD Power current that the module can pass through to the next module in the system. The specific level of current passed through varies based on system configuration.
- (6) Maximum level of SA Power current that the module can pass through to the next module in the system. The specific level of current passed through varies based on system configuration.
- (7) Use this conductor category information for planning conductor routing. See the Industrial Automation Wiring and Grounding Guidelines, publication [1770-4.1](#).

Compact GuardLogix Controllers Product Comparison

Table 22 - Technical Specifications

Attribute	Compact GuardLogix 1768-L4 Controller	Compact GuardLogix 5380 Controller
Memory	1768-L43S: 2 MB + 0.5 MB Safety 1768-L45S: 3 MB + 1 MB Safety	5069-L306ERS2, 5069-L306ERMS2, 5069-L3100ERMS3: 0.6 MB + 0.3 MB Safety 5069-L310ERS2, 5069-L310ERMS2, 5069-L310ERMS3: 1 MB + 0.5 MB Safety 5069-L320ERS2, 5069-L320ERMS2, 5069-L320ERMS3: 2 MB + 1 MB Safety 5069-L330ERS2, 5069-L330ERMS2, 5069-L330ERMS3: 3 MB + 1.5 MB Safety 5069-L340ERS2, 5069-L340ERMS2, 5069-L340ERMS3: 4 MB + 2 MB Safety 5069-L350ERS2, 5069-L350ERMS2, 5069-L350ERMS3: 5 MB + 2.5 MB Safety 5069-L380ERS2, 5069-L380ERMS2, 5069-L380ERMS3: 8 MB + 4 MB Safety 5069-L3100ERS2, 5069-L3100ERMS2, 5069-L3100ERMS3: 10 MB + 5 MB Safety
Local I/O modules supported	<ul style="list-style-type: none"> 1769 Compact I/O only Number of local I/O modules that are supported varies by controller catalog number 	<ul style="list-style-type: none"> Compact 5000 I/O Standard and Safety modules only Number of local I/O modules that are supported varies by controller catalog number
Remote I/O modules supported	<ul style="list-style-type: none"> 1794 FLEX I/O 1769 Compact I/O 1756 ControlLogix I/O 1734 POINT I/O 1732E ArmorBlock 	<ul style="list-style-type: none"> 5094 FLEX 5000 I/O⁽¹⁾ 5069 Compact 5000 I/O⁽²⁾ 5034 PointMax I/O⁽³⁾ 5032 ArmorBlock 5000 I/O⁽⁴⁾ 1794 FLEX I/O 1769 Compact I/O 1756 ControlLogix I/O 1734 POINT I/O 1732E ArmorBlock
Safety I/O support	<ul style="list-style-type: none"> 1734 POINT Guard I/O™, 1732 ArmorBlock® Guard I/O™, 1791 CompactBlock™ Guard I/O™ Can only communicate to safety I/O through the embedded Ethernet ports. 	<ul style="list-style-type: none"> Compact 5000 I/O Safety modules, 1734 POINT Guard I/O, 1732 ArmorBlock Guard I/O, 1791 CompactBlock Guard I/O, FLEX 5000 I/O Safety modules, 1756 ControlLogix® Digital Safety I/O Can communicate to local safety I/O through the backplane, and also communicate to distributed safety I/O through the embedded Ethernet ports. Can communicate to DeviceNet® safety I/O nodes with the 1788-EN2DNR Ethernet to DeviceNet linking device.
Ethernet performance	<ul style="list-style-type: none"> No embedded Ethernet port, you must use a 1768 EtherNet/IP communication module. The communication rate of 1768 EtherNet/IP communication modules is 10/100 Mbps. Dual -IP moder is not supported. 1768-L4 controllers use connections, not Ethernet nodes. Each 1768-ENBT or 1768-EWEB module in an EtherNet/IP network can provide messaging support for 128 Logix connections and 64 TCP/IP connections. 	<ul style="list-style-type: none"> Embedded EtherNet/IP port 10/100/1000 Mbps communication rate Support for Dual-IP mode with the Logix Designer application, version 31 or later EtherNet/IP nodes, instead of connections. For information on EtherNet/IP nodes, see Nodes on an EtherNet/IP Network on page 33.
Unconnected message buffers	No fixed limits, as long as the controller can allocate the buffer it will.	320 - Any combination of outgoing or incoming unconnected messages.
Concurrent cached message instructions in the running state	32, drawn from the 250 total connections supported by the controller.	256 dedicated buffers
HMI and Messaging (Class 3)	Drawn from the 250 total connections supported by the controller.	512 dedicated messages (256 incoming messages and 256 outgoing messages)
Integrated motion	Not supported	EtherNet/IP network
Motion axes	Not supported	<p>5380 controllers supports from 2 to 32 axes depending on catalog number. Any combination of these supported axis types:</p> <ul style="list-style-type: none"> CIP Consumed Virtual Position loop drives <p>As many as 32 Axes/ms when you use the built-in EtherNet/IP port at 1 Gbps. IMPORTANT: Not all CompactLogix 5380 controllers support Integrated Motion over an EtherNet/IP network.</p>

Table 22 - Technical Specifications

Attribute	Compact GuardLogix 1768-L4 Controller	Compact GuardLogix 5380 Controller
Voltage and current ratings	<p>1768-L43S Backplane current: 1.4 A @ 24V DC 1768 backplane current output: 2.8 A @ 5.2V DC 1769 backplane current output: 2.0 A @ 5.2V DC Total 1768 and 1769 backplane current output: 4.8 A @ 5.2V DC</p> <p>1768-L45S Backplane current: 2.1 A @ 24V DC 1768 backplane current output: 5.6 A @ 5.2V DC 1769 backplane current output: 2.0 A @ 5.2V DC Total 1768 and 1769 backplane current output: 7.6 A @ 5.2V DC</p>	<p>Compact GuardLogix 5380 SIL 2 controllers:</p> <ul style="list-style-type: none"> • MOD Power: 475 mA @ 18...32V DC • MOD Power Inrush: 1200 mA for 125 ms • SA Power: 10 mA @ 0...32V DC • MOD Power (Passthrough)⁽⁵⁾: 4.525 A @ 18...32V DC • SA Power (Passthrough)⁽⁶⁾: 9.99 A @ 0...32V DC <p>Compact GuardLogix 5380 SIL 3 controllers:</p> <ul style="list-style-type: none"> • MOD Power: 475 mA @ 18...32V DC • MOD Power Inrush: 1200 mA for 125 ms • SA Power: 10 mA @ 0...32V DC • MOD Power (Passthrough)⁽⁷⁾: 4.525 A @ 18...32V DC • SA Power (Passthrough)⁽⁸⁾: 9.99 A @ 0...32V DC
Energy storage module	Not applicable. Energy stored in the 1768 power supply maintains controller power long enough to store the program to internal flash memory (not the external CompactFlash card).	Non-removable
Weight, approx	0.45 kg (0.99 lb)	<p>Compact GuardLogix 5380 SIL 2 controllers: 0.768 kg (1.693 lb)</p> <p>Compact GuardLogix 5380 SIL 3 controllers: 1.2 kg (2.645 lb)</p>
Wire category ⁽⁹⁾	2 - on communication ports	<p>3 - on USB port</p> <p>1 - on power ports</p> <p>2 - on Ethernet port</p>
Wire size	1756-CP3 or 1747-CP3, right angle connector to controller, straight to serial port, 3 m	Ethernet connections: Ethernet Cabling and Installation according to IEC 61918 and IEC 61784-5-2
Removable terminal block	Not applicable	<p>Kit 5069-RTB64-SCREW or kit 5069-RTB64-SPRING You must order the kit separately. RTBs do not ship with the controller. 5069-RTB4-SCREW, 5069-RTB6-SCREW connections: 0.5...1.5 mm² (22...16 AWG) solid or stranded copper wire rated at 105 °C (221 °F), or greater, 3.5 mm (0.14 in.) max diameter including insulation, single wire connection only 5069-RTB4-SPRING, 5069-RTB6-SPRING connections: 0.5...1.5 mm² (22...16 AWG) solid or stranded copper wire rated at 105 °C (221 °F), or greater, 2.9 mm (0.11 in.) max diameter including insulation, single wire connection only</p>
Reset Button	<p>If you access the button after power is applied to the controller, the controller resets the RS-232 configuration setting to the defaults</p> <p>If you access the button while the controller is powering up, the controller clears the user program from controller memory.</p>	<p>A Stage 1 reset clears the application program and memory, but retains the IP address and all object attributes designated as non-volatile. A Stage 1 reset occurs only if the controller contains a user application.</p> <p>A Stage 2 reset returns the controller to out-of box settings, including firmware, and clears all network settings. A Stage 2 reset occurs only if the controller does not contain a user application, and the current controller firmware is not a 1.x revision.</p> <p>For information on how to use the reset button, see the CompactLogix 5380 and Compact GuardLogix 5380 Controllers User Manual, publication 5069-UM001.</p>

(1) With Studio 5000 Logix Designer application, version 32.00.00 or later.

(2) With Studio 5000 Logix Designer application, version 31.00.00 or later.

(3) With Studio 5000 Logix Designer application, version 36.00.00 or later.

(4) With Studio 5000 Logix Designer application, version 35.00.00 or later.

(5) Maximum level of MOD Power current that the module can pass through to the next module in the system. The specific level of current passed through varies based on system configuration.

(6) Maximum level of SA Power current that the module can pass through to the next module in the system. The specific level of current passed through varies based on system configuration.

(7) Maximum level of MOD Power current that the module can pass through to the next module in the system. The specific level of current passed through varies based on system configuration.

(8) Maximum level of SA Power current that the module can pass through to the next module in the system. The specific level of current passed through varies based on system configuration.

(9) Use this conductor category information for planning conductor routing. See the Industrial Automation Wiring and Grounding Guidelines, publication [1770-4.1](#).

Controller Spacing

Controller spacing differs between the 1769-L3 and 1768-L4 controllers and the 5380 controllers. The graphics in this section are not to scale.

CompactLogix 1769-L3 Spacing

Maintain spacing from enclosure walls, wireways, and adjacent equipment. Allow 50 mm (2 in.) of space on all sides, as shown. This provides ventilation and electrical isolation.

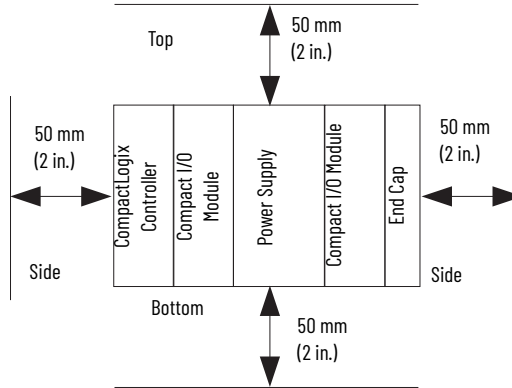

CompactLogix 1768-L4 and Compact GuardLogix 1768-L4 Spacing

Allow for the minimum clearance from enclosure walls, wireways, and other equipment.

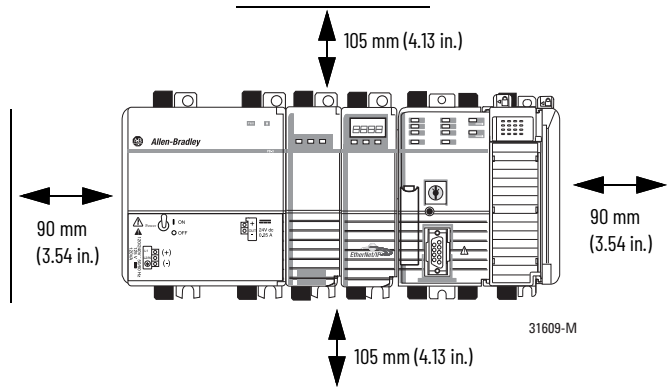

CompactLogix 5380 Spacing

Maintain spacing from enclosure walls, wireways, and adjacent equipment.

The minimum distance on all sides of the CompactLogix 5380 system varies based on the operating temperature, as follows:

- 50.80 mm (2.00 in.) at 55 °C (131 °F)
- 101.60 mm (4.00 in.) at 60 °C (140 °F)

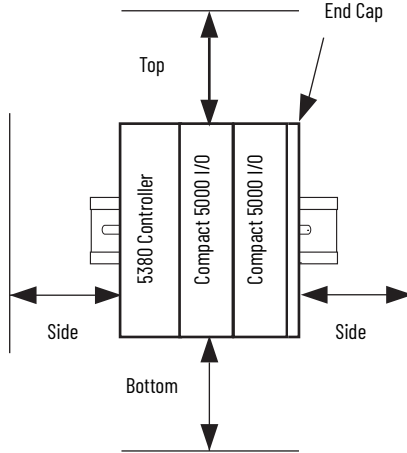

Compact GuardLogix 5380 Spacing

Maintain spacing from enclosure walls, wireways, and adjacent equipment. The minimum distance on all sides of the Compact GuardLogix 5380 system varies based on the operating temperature, as follows:

Compact GuardLogix SIL2 Controllers	<p>Series A catalog numbers:</p> <ul style="list-style-type: none"> • 50.80 mm (2.00 in.) at 50 °C (131 °F) • 101.60 mm (4.00 in.) at 55 °C (122 °F) • 152.40 mm (6.00 in.) at 60 °C (140 °F) <p>Series B catalog numbers:</p> <ul style="list-style-type: none"> • 50.8 mm (2.00 in.) at 55 °C (131 °F) • 101.6 mm (4.00 in.) at 60 °C (140 °F)
-------------------------------------	---

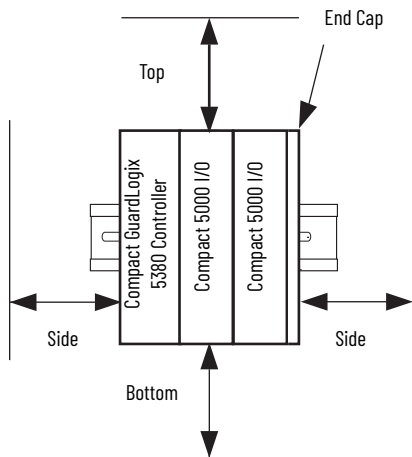

Controller Dimensions

This section shows dimensional differences.

CompactLogix 1769-L3 Dimensions

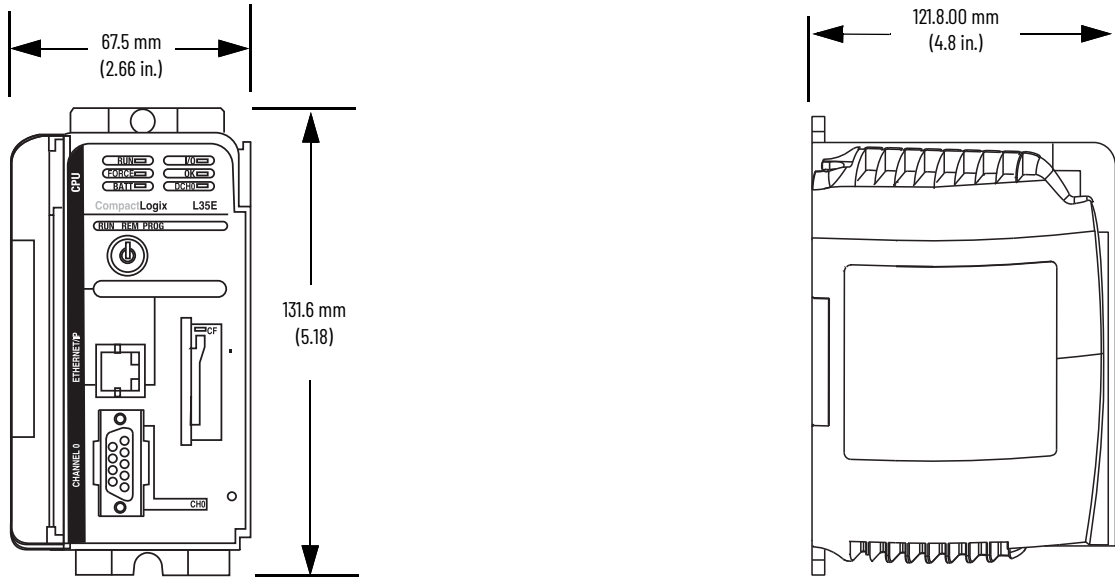

CompactLogix 1768-L4 Dimensions

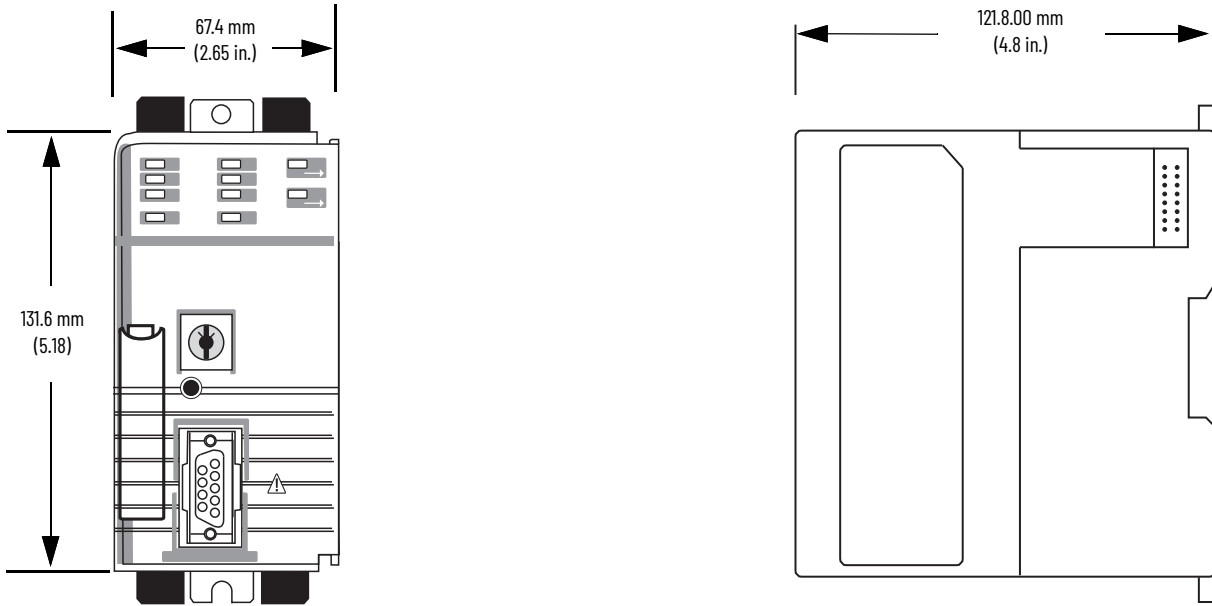

CompactLogix 5380 Dimensions

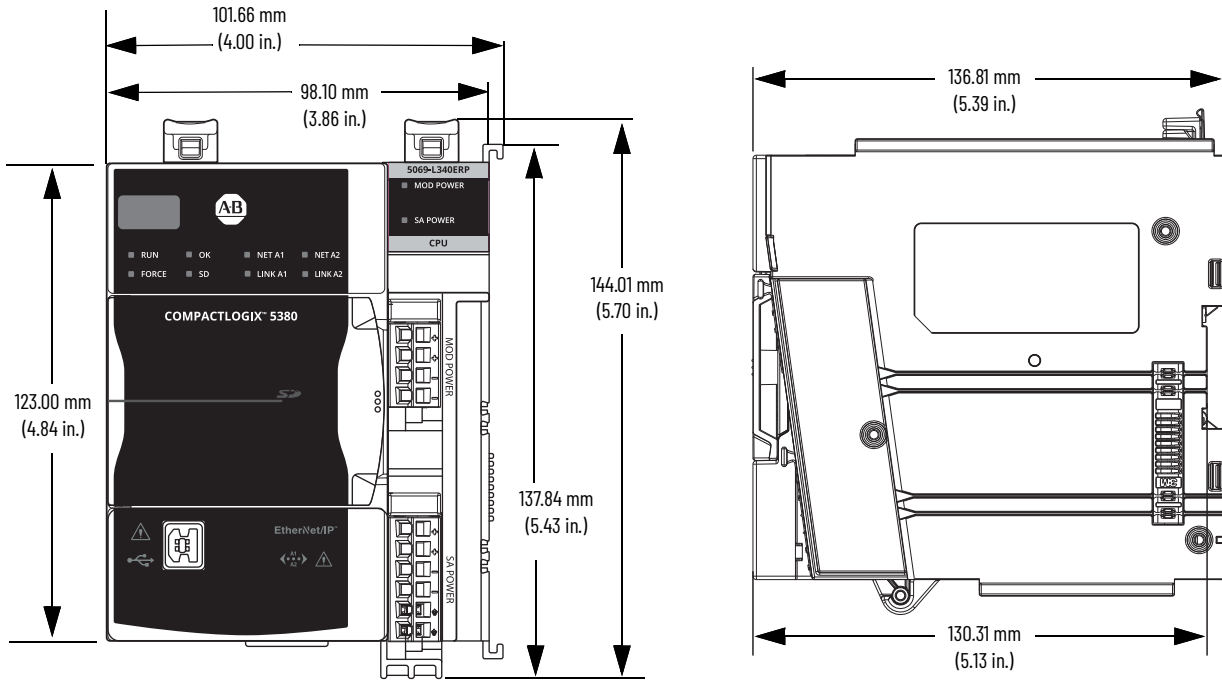

Compact GuardLogix 1768-L4 Dimensions

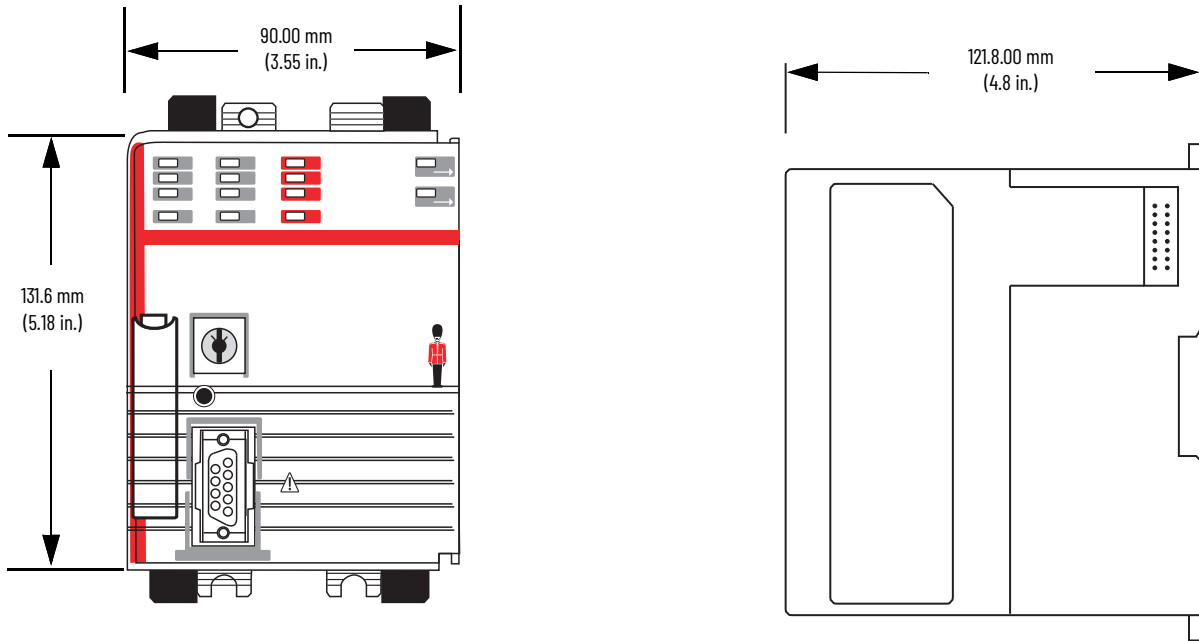

Compact GuardLogix 5380 SIL 2 Controller Dimensions

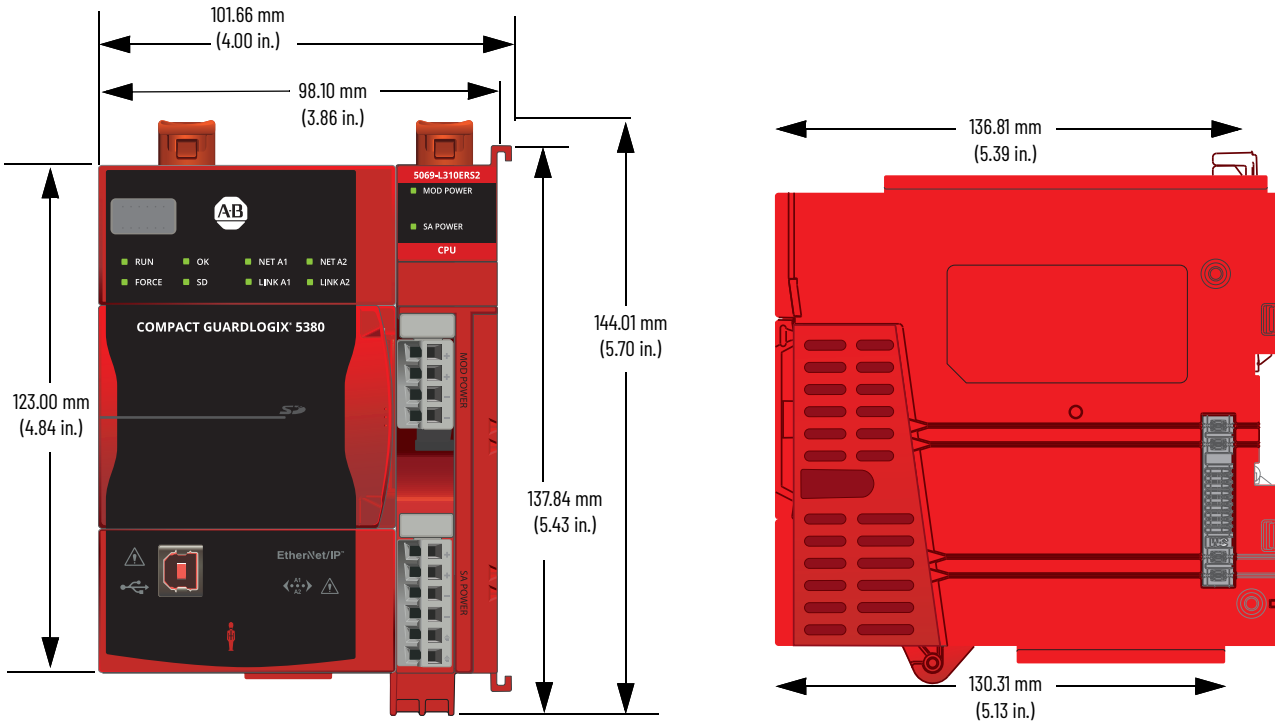

Connectors and Status Indicators

The following tables shows the differences between the connectors and status indicators. For more information on the controller status indicators and reset button, see Chapter 10, [Diagnostics and Status Indicators with CompactLogix Systems on page 193](#).

CompactLogix 1769-L3		CompactLogix 1768-L4	
Item	Description	Item	Description
1	Status Indicators	1	Status Indicators
2	Communication port (Ethernet or ControlNet depending on catalog number).	2	Reset button
3	RUN REM PROG mode switch	3	Compact Flash card slot behind the door
4	Compact Flash card slot	4	RUN REM PROG mode switch
5	Serial Port	5	Serial Port

CompactLogix 5380

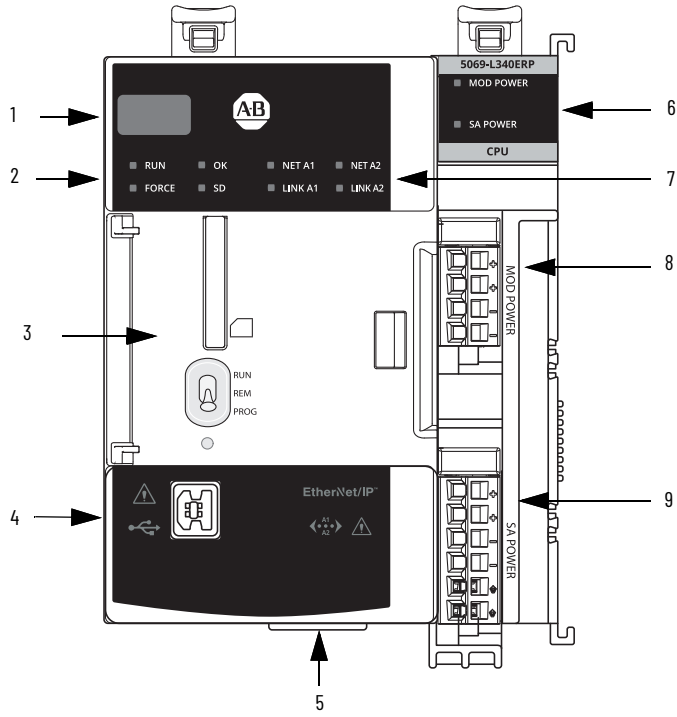

Item	Description
1	4-character display
2	Controller Status Indicators
3	Behind the door: <ul style="list-style-type: none"> • RUN REM PROG mode switch • Reset button • SD card slot
4	USB port
5	Ethernet ports 1 and 2
6	Power Status Indicators
7	EtherNet/IP Status Indicators
8	MOD power connection
9	SA power connection

Compact GuardLogix 1768-L4

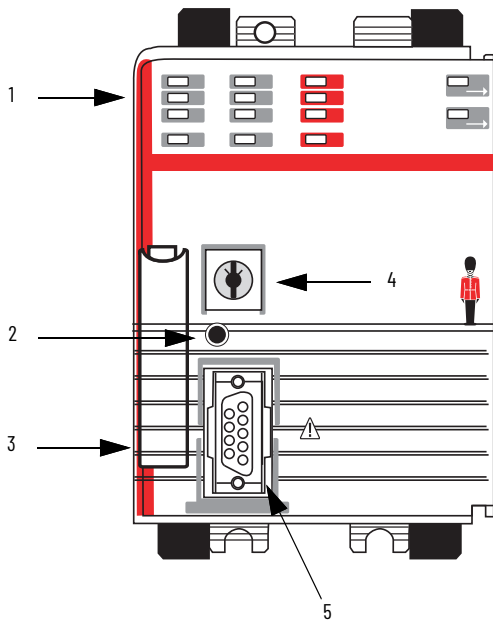

Item	Description
1	Status Indicators
2	Reset button
3	Compact Flash card slot behind the door
4	RUN REM PROG mode switch
5	Serial Port

Compact GuardLogix 5380 SIL 2

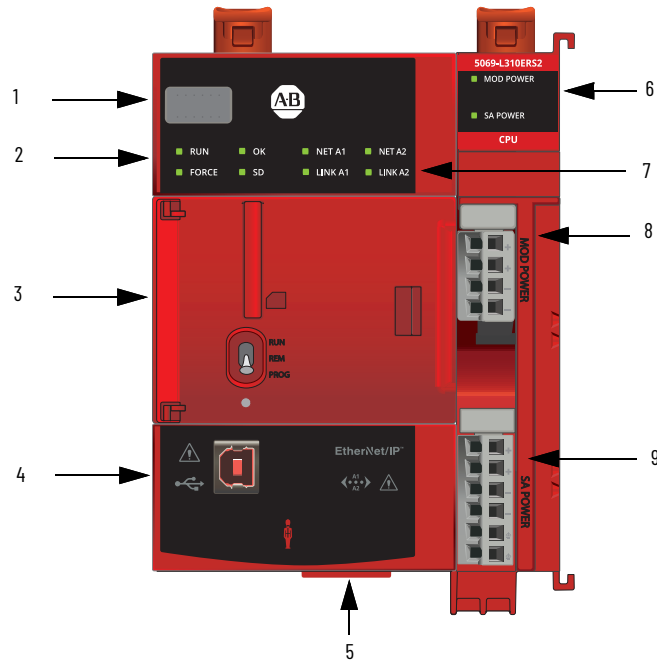

Item	Description
1	4-character display
2	Controller Status Indicators
3	Behind the door: • RUN REM PROG mode switch • Reset button • SD card slot
4	USB port
5	Ethernet ports 1 and 2
6	Power Status Indicators
7	EtherNet/IP Status Indicators
8	MOD power connection
9	SA power connection

Power the Controller

There are differences in how to power the 5380 controllers versus the 1769-L3 and 1768-L4 controllers. [Table 23](#) highlights some of the power differences.

For information on how to power your system, see the CompactLogix 5380 and Compact GuardLogix 5380 Controllers User Manual, publication [5069-UM001](#).

Table 23 - Power Differences

	CompactLogix 1769-L3 System	CompactLogix 1768-L4 System, Compact GuardLogix 1768-L4 System	CompactLogix 5380 System	Compact GuardLogix 5380 System
Power source	External power supply	External power supply	External power supply	
Power source location	Compact I/O power supplies distribute power from either side of the power supply.	The 1768 CompactLogix power supply distributes power from the right side of the supply and must be the leftmost module in the system.	Separate from the system and connected to RTBs on controller The modules installed in the system do not impact the power supply location. Power is transferred to the system via removable terminal blocks (RTBs) on the controller.	
Power types provided	System-side power.	System-side power. With a 1768-L4 controller installed, the 1768-PA3 and 1768-PB3 power supplies also offer a 24V DC external power source. <ul style="list-style-type: none"> The power supply sends 24V DC to the controller in slot 0. The controller converts the 24V DC to 5V DC and 24V DC, and distributes the power as needed. <ul style="list-style-type: none"> 5V/24V power to 1769 I/O modules on the right side of the controller 5V power to communication or motion modules on the left side of the controller 	<ul style="list-style-type: none"> System-side power via MOD Power RTB Field-side power via SA Power RTB IMPORTANT: RTBs do not ship with the controller. The RTBs are available in kits that you must order separately. Kit 5069-RTB64-SCREW contains screw-type RTBs that are used for MOD power and SA power. Kit 5069-RTB64-SPRING contains spring-type RTBs that are used for MOD power and SA power.	
Current type provided	Field-side power - AC or DC as dictated by system design.	DC only.	<ul style="list-style-type: none"> System-side power - DC only Field-side power - AC or DC as dictated by system design 	<ul style="list-style-type: none"> System-side power - DC only Field-side power - DC only at the controller, AC only through the use of a local 5069-FPD, Field Potential Distributor module.
Special requirement	<ul style="list-style-type: none"> The CompactLogix 1769-L3 controller has a power supply distance-rating of four modules. The controller must be the leftmost module in the first bank of the system. 	<ul style="list-style-type: none"> 1769 modules have a power supply distance rating from 4...8 modules, depending on the module. 1768 modules do not have a distance rating to the 1768 power supply. Place 1769 modules to the right of the 1768 backplane. Place 1768 modules between the power supply and the controller. 	<ul style="list-style-type: none"> Must track the system-side and field-side power consumption to properly size the external power supplies that provide each power type. Must use 5069-FPD, Field Potential Distributor if SA Power consumption is exceeded before reaching max of 31 local I/O modules. Must use Field Potential Distribution module to change SA Power potential between AC and DC. 	

Nonvolatile Memory

5380 controllers use a Secure Digital (SD) card, while 1769-L3 and 1768-L4 controllers use a Compact Flash card.

The 5380 controller has changed some behavior when loading a project from the memory card into a controller. The changes facilitate an easier commissioning of new, out-of-box controllers. All Logix 5000® controllers ship from the factory with firmware revision 1.x.

With 5380 controllers, the Load Image setting On Uninitialized Memory is available. This setting replaces the On Corrupt Memory setting that is available with 1769-L3 and 1768-L4 controllers.

The general behavior is the same for both settings. The only difference is the controller behavior when it is in the out-of-box condition.

[Table 24](#) shows what happens at power-up when you insert a memory card that contains an image into a 5380 controller.

Table 24 - 5380 Memory Card Settings and Controller Power-up Behavior

Image Setting	Controller is in Out-of-Box Condition (Firmware Revision 1.x)	Firmware > 1.x and Internal Nonvolatile Memory is Not Valid ⁽¹⁾	Firmware > 1.x and Internal Nonvolatile Memory is Valid ⁽¹⁾
User Initiated	Loads Firmware Only ⁽²⁾	Does Nothing	Does Nothing
On Power Up	Loads both Firmware and Application	<ul style="list-style-type: none"> Loads Firmware if there is a revision mismatch Loads Application 	<ul style="list-style-type: none"> Loads Firmware if there is a revision mismatch Loads Application
On Uninitialized Memory	Loads both Firmware and Application ⁽²⁾	<ul style="list-style-type: none"> Loads Firmware if there is a revision mismatch Loads Application 	Does Nothing

(1) "Valid" includes the No Project condition.

(2) Indicates change in behavior from 1769-L3 and 1768-L4 controllers.

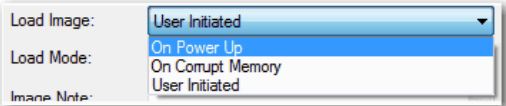
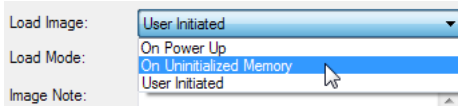
1769-L3, 1768-L4 Controllers	5380 Controllers
	

Communication Options

The 5380 controllers can operate on EtherNet/IP networks. 1769-L3 and 1768-L4 controllers can operate on EtherNet/IP, ControlNet, and DeviceNet networks.

- IMPORTANT** Be aware of the following:
- The 5380 controllers do not support for half-duplex communications on Ethernet at any speed.

Application Type	1769-L3, 1768-L4 Controllers Support	5380 Controllers Support
Network communication option	<ul style="list-style-type: none"> EtherNet/IP ControlNet DeviceNet (1769-L3 controllers and standard 1768-L4 controllers only) 	EtherNet/IP
EtherNet/IP mode options	Can be used in linear and star topologies. Does not support for Dual-IP mode.	<ul style="list-style-type: none"> Linear/DLR mode Dual-IP mode - Available with the Logix Designer application, version 29 or later Both modes can be used in linear, DLR, and star topologies.
Integrated Motion	1769-L3 controllers: Not Supported 1768-L4 standard controllers: SERCOS	EtherNet/IP
Control of distributed I/O	<ul style="list-style-type: none"> EtherNet/IP ControlNet DeviceNet (1769-L3 controllers and standard 1768-L4 controllers only) 	EtherNet/IP
Produce/consume data between controllers	<ul style="list-style-type: none"> EtherNet/IP ControlNet 	EtherNet/IP
Messaging to and from other devices, including access to the controller via Logix Designer application	<ul style="list-style-type: none"> EtherNet/IP DeviceNet, only to devices (1769-L3 controllers and standard 1768-L4 controllers only) ControlNet network Serial networks DH-485 networks 	EtherNet/IP

EtherNet/IP Communication

Attribute	CompactLogix 1769-L3 Controller	CompactLogix 1768-L4 Controller	CompactLogix 5380 Controller
Ethernet performance	<ul style="list-style-type: none"> Embedded EtherNet/IP port 10/100 Mbps communication rate Can be used in linear and star topologies. Does not support Dual-IP mode. 1769-L3 controllers use connections, not Ethernet nodes. 	<ul style="list-style-type: none"> No embedded Ethernet port, you must use a 1768 EtherNet/IP communication module. The communication rate of 1768 EtherNet/IP communication modules is 10/100 Mbps. Dual-IP mode is not supported. 1768-L4 controllers use connections, not Ethernet nodes. Each 1768-ENBT or 1768-EWEB module in an EtherNet/IP network can provide messaging support for 128 Logix connections and 64 TCP/IP connections. Can be used in linear and star topologies. Does not support for Dual-IP mode. 	<ul style="list-style-type: none"> Embedded EtherNet/IP port 10/100/1000 Mbps communication rate Support for Dual-IP mode with the Logix Designer application, version 29 or later EtherNet/IP nodes, instead of connections. For information on EtherNet/IP nodes, see Nodes on an EtherNet/IP Network on page 94. Linear/DLR mode Dual-IP mode - Available with the Logix Designer application, version 29 or later Both modes can be used in linear, DLR, and star topologies.

ControlNet Communication

The 5380 controllers do not support ControlNet communication, you must redesign your application to use EtherNet/IP communication.

For more information, see these publications:

- ControlNet to EtherNet/IP Migration Reference Manual, publication [CNET-RM001](#).
- For EtherNet/IP information, see the CompactLogix 5380 and Compact GuardLogix 5380 Controllers User Manual, publication [5069-UM001](#)

Serial Communication

The 5380 controllers do not have a serial port, so you must add a 5069-SERIAL module for serial communication.

For how to use the 5069-Serial Module, see the Compact 5000 I/O Serial Module User Manual, publication [5069-UM003](#).

Notes:

Migrate a PIDE Instruction to a PPID Instruction

The 5590 controllers do not support the Enhanced PID (PIDE) instruction. When you convert a 5580 controller project with PIDE instructions to a 5590 controller project, you must convert PIDE instructions to Process Proportional + Integral + Derivative (PPID) instructions.

The PPID instruction is not identical to the PIDE instruction, but it provides equivalent functionality and some enhancements.

Consider the following before you convert PIDE instructions to PPID instructions.

Consideration	More Information, See
Both instructions are available in the following programming languages: <ul style="list-style-type: none"> Function Block Structured Text The PPID instruction is also available in Ladder Logic.	—
With 5580 controllers, the PPID instruction is only available to Process controllers. You can use the PPID instruction with any 5590 controller. IMPORTANT: When a project that contains the PIDE instruction is opened with a 5590 controller, it fails verification, and an error message is displayed. The message is as follows: <i>Invalid instruction reference, PIDE is not available for this controller type. Using PPID is recommended.</i>	—
Some parameters that are available in the PIDE instruction have a one-to-one equivalent parameter in the PPID instruction	<ul style="list-style-type: none"> Equivalent Input Parameters on page 224 Equivalent Output Parameters on page 240
Some parameters that are available in the PIDE instruction have an alternative parameter that is available in the PPID instruction.	<ul style="list-style-type: none"> Alternative Input Parameters on page 235 Alternative Output Parameters on page 245
Some input parameters that are available in the PIDE instruction can be used in an equivalent way in the PPID instruction or, depending on application specifics, can be used in the PPID instruction in an alternative approach	Equivalent or Alternative Input Parameters on 236
Some parameters that are available in the PIDE instruction have no equivalent in the PPID instruction.	<ul style="list-style-type: none"> No Equivalent Input Parameters on page 238 No Equivalent Output Parameters on page 247
The PPID instruction uses Alarming differently from the PIDE instruction.	Differences In Alarming on page 248
The PPID operates in Periodic mode. Oversample and Real Time Sampling are not available. As a result, some time mode parameters are not available with the PPID instructions.	Timing Mode Parameters That Are Not Available In PPID Instruction on page 253
The zero crossing deadband in the PIDE instruction is the PV deviation deadband in the PPID instruction.	Zero Crossing Deadband and Process Variable Deviation Deadband on page 254
The PIDE instruction configures control variable (CV) rate of change in percent per second, and the PPID instruction configures it in CVEU per second.	Control Variable Rate of Change Limiting on page 256
CV manual limiting in the PIDE instruction is functionally opposite of CV manual limiting in the PPID instruction.	Control Variable Manual Limiting on page 258
Some CV-related inputs are handled differently in the PPID instruction than in the PIDE instruction.	Differences In Control Variable Related Inputs on page 259
Override is slightly different in the PPID instruction compared to the PIDE instruction.	Differences in Override on page 259
In the PPID instruction, operator inputs and commands are available only as private members, unlike PIDE instruction.	Differences in Operator Mode on page 262
The PIDE instruction uses operator mode members differently.	Differences in Operator Mode on page 262

Consideration	More Information, See
The cascade mode behaves slightly differently in the PPID instruction than in the PIDE instruction.	Differences in Cascade on page 265
The PPID instruction handles process variable (PV) value outside engineering units (EU) differently from the PIDE instruction.	Differences in PV Clamping on page 265
There are differences between parameters related to CV scaling and limits in the PIDE and PPID instructions.	Differences in Control Variable Scaling and Limits Configuration on 266
The PPID instruction does not support autotuning.	Autotuning is Not Available In the PPID Instruction on page 266

Equivalent Input Parameters

The following table describes the equivalent input parameters between the PIDE instruction and the PPID instruction. The parameters are a one-to-one match when you migrate from the PIDE instruction to the PPID instruction.

Table 25 - Equivalent Input Parameters - PIDE Instruction and PPID Instruction

PIDE Instruction			PPID Instruction		Comment
Parameter	Data Type	Description	Parameter	Description	
EnableIn	BOOL	Enable input. If false, the instruction does not execute, and outputs are not updated. Default is true.	EnableIn	Enable input. Ladder Diagram: Corresponds to the rung condition. Default is true.	—
PV	REAL	Scaled process variable (PV) input. This value is typically read from an analog input module. Valid = any float Default = 0.0	Inp_PV	Process Variable (PVEU). Valid any float Default = 0.0	—
PVFault	BOOL	PV bad health indicator. If PV is read from an analog input, then PVFault is normally controlled by the analog input fault status. When PVFault is true, it indicates that the input signal has an error. Default is false = good health	Inp_PVBad	1 = PV quality or PV I/O communications status bad 0 = OK Default is false.	—
PVEUMax	REAL	Maximum scaled value for PV. The value of PV and setpoint (SP) that corresponds to 100 percent span of the Process Variable. Valid = PVEUMin < PVEUMax ≤ maximum positive float Default = 100.0	Cfg_PVEUMax	PV maximum value for scaling from engineering units to %, PV at 100% (PVEU). Valid any float > Cfg_PVEUMin. Default is 100.0.	PPID parameters Cfg_PVEUMax and Cfg_PVEUMin are used for clamping of Inp_PV so they must be set according to the real Inp_PV span. For more information, see Differences in PV Clamping on page 265 .
PVEUMin	REAL	Minimum scaled value for PV. The value of PV and SP corresponds to 0 percent span of the Process Variable. Valid = maximum negative float ≤ PVEUMin < PVEUMax Default = 0.0	Cfg_PVEUMin	PV minimum value for scaling from engineering units to %, PV at 0% (PVEU). Valid any float < Cfg_PVEUMax. Default is 0.0.	
SPProg	REAL	SP program value scaled in PV units. SP is set to this value when in Program control and not Cascade/Ratio mode. If the value of SPProg < SPLLimit or > SPHLimit, the instruction sets the appropriate bit in Status and limits the value that is used for SP. Valid = SPLLimit to SPHLimit Default = 0.0	PSet_SP	Program setting for SP, loop mode Auto (PVEU). Valid any float. Default is 0.0.	The tag description contains a difference in: <ul style="list-style-type: none"> • PIDE: Valid = SPLLimit to SPHLimit • PPID: Valid any float. There is no difference in the clamping function, so PPID setpoint is also clamped between Cfg_SPLoLim and Cfg_SPHiLim. There is no specific status bit for Inp_CascSP outside the setpoint limits in the PPID instruction. There is a general status Sts_SPclamped when setpoint from any source is clamped.

Table 25 - Equivalent Input Parameters - PIDE Instruction and PPID Instruction (Continued)

PIDE Instruction			PPID Instruction		Comment
Parameter	Data Type	Description	Parameter	Description	
SPCascade	REAL	SP Cascade value scaled in PV units. If CascadeRatio is true and UseRatio is false, then SP = SPCascade. This is typically the CVEU of a primary loop. If CascadeRatio and UseRatio are true, then SP = (SPCascade x Ratio). If the value of SPCascade < SPLLlimit or > SPHlimit, set the appropriate bit in Status and limit the value that is used for SP. Valid = SPLLlimit to SPHlimit Default = 0.0	Inp_CascSP	SP in Cascade loop mode, independent PV in Ratio loop mode (PVEU). Valid any float. Default is 0.0.	There is a difference in valid range. • PIDE: Valid = SPLLlimit to SPHlimit • PPID: Valid any float. There is no difference in the clamping function, so PPID setpoint is also clamped between Cfg_SPLoLim and Cfg_SPHiLim. There is no specific status bit for Inp_CascSP outside the setpoint limits in the PPID instruction, there is a general status Sts_SPClamped when setpoint from any source is clamped. For more information, see: Differences in Cascade on page 265
SPHlimit	REAL	SP high limit value scaled in PV units. If SPHlimit > PVEUMax, the instruction sets the appropriate bit in Status. Valid = SPLLlimit to PVEUMax Default = 100.0	Cfg_SPHiLim	Maximum allowed SP value (PVEU). Valid any float \geq Cfg_SPLoLim and \leq Cfg_PVEUMax. Default is 100.0.	There is a difference how the PPID handles invalid configuration when Cfg_SPHiLim < Cfg_SPLoLim. For more information, see the SP Handling section in the PPID instruction online help.
SPLLlimit	REAL	SP low limit value scaled in PV units. If SPLLlimit < PVEUMin, the instruction sets the appropriate bit in Status. If SPHlimit < SPLLlimit, the instruction sets the appropriate bit in Status and limits SP using the value of SPLLlimit. Valid = PVEUMin to SPHlimit Default = 0.0	Cfg_SPLoLim	Minimum allowed SP value (PVEU). Valid any float \leq Cfg_SPHiLim and \geq Cfg_PVEUMin. Default is 0.0.	
UseRatio	BOOL	Allow ratio control permissive. Set to true to enable ratio control when in Cascade/ Ratio mode. Default is false.	Cfg_HasRatio	1 = Cascade loop mode is Ratio 0 = Cascade loop mode is Cascade. Default is false.	For more information, see Differences in Cascade on page 265
RatioProg	REAL	Ratio program multiplier. Ratio and RatioOper are set equal to this value when in Program control. If RatioProg < RatioLLimit or > RatioHlimit, the instruction sets the appropriate bit in Status and limits the value that is used for Ratio. Valid = RatioLLimit to RatioHlimit Default = 1.0	PSet_Ratio	Program setting for Ratio, loop mode Cascade/Ratio and Ratio enabled (unitless). Valid = 0.0 to maximum positive float. Default is 1.0.	The tag description contains a difference in: • PIDE: Valid = RatioLLimit to RatioHlimit • PPID: Valid 0.0 to maximum positive float. There is no difference in the clamping function, so PPID ratio is also clamped between Cfg_RatioLoLim and Cfg_RatioHiLim. There is no specific status bit for PSet_Ratio outside the ratio limits in the PPID instruction, there is a general status Sts_RatioClamped when ratio from any source is clamped.
RatioHlimit	REAL	Ratio high limit value. Limits the value of Ratio obtained from RatioProg or RatioOper. If RatioHlimit < RatioLLimit, the instruction sets the appropriate bit in Status and limits Ratio using the value of RatioLLimit. Valid = RatioLLimit to maximum positive float Default = 1.0	Cfg_RatioHiLim	Maximum allowed Ratio value (unitless). Valid any float \geq Cfg_RatioLoLim. Default is 1.0.	There is a difference between instructions when ratio limits are not valid. • PIDE: Limits ratio using the value of RatioLLimit • PPID: Sets ratio equal to 1.0

Table 25 - Equivalent Input Parameters - PIDE Instruction and PPID Instruction (Continued)

PIDE Instruction			PPID Instruction		Comment
Parameter	Data Type	Description	Parameter	Description	
RatioLLimit	REAL	Ratio low limit value. Limits the value of Ratio obtained from RatioProg or RatioOper. If RatioLLimit < 0, the instruction sets the appropriate bit in Status and limits the value to zero. If RatioHLimit < RatioLLimit, the instruction sets the appropriate bit in Status and limits Ratio using the value of RatioLLimit. Valid = 0.0 to RatioHLimit Default = 1.0	Cfg_RatioLoLim	Minimum allowed Ratio value (unitless). Valid any float ≤ Cfg_RatioHiLim Default is 0.0	<p>There is a difference in valid range:</p> <ul style="list-style-type: none"> • PIDE: Valid = 0.0 to RatioHLimit • PPID: Valid any float ≤ Cfg_RatioHiLim. <p>There is no status set in the PPID instruction if Cfg_RatioLoLim < 0. There is a difference in default value:</p> <ul style="list-style-type: none"> • PIDE: Default = 1.0 • PPID: Default is 0.0. <p>There is a difference when ratio limits are not valid:</p> <ul style="list-style-type: none"> • PIDE: Limits ratio using the value of RatioLLimit • PPID: Sets ratio equal to 1.0
CVFault	BOOL	Control variable bad health indicator. If CVEU controls an analog output, then CVFault normally comes from the analog output's fault status. When true, CVFault indicates an error on the output module and the instruction sets the appropriate bit in Status. Default is false = good health	Inp_CVIOFault	1 = CV I/O communications status bad 0 = OK Default is false	—
CVProg	REAL	CV program manual value. CV equals this value when in Program Manual mode. If CVProg < 0 or > 100, or < CVLLimit or > CVHLimit when CVManLimiting is true, the instruction sets the appropriate bit in Status and limits the CV value. Valid = 0.0...100.0 Default = 0.0	PSet_CV	Program setting for CV when loop mode is Manual (CVEU). Valid any float. Default is 0.0	<p>The tag description contains differences in units and valid range.</p> <ul style="list-style-type: none"> • PIDE: <ul style="list-style-type: none"> - Uses percent - Valid = 0.0...100.0 • PPID: <ul style="list-style-type: none"> - Has CVEU - Valid any float <p>There is no status set in the PPID instruction when PSet_CV is outside Cfg_CVEUMin and Cfg_CVEUMax limits (these correspond to PIDE 0% and 100%). There is no specific status bit for PSet_CV outside the Cfg_CVLoLim and Cfg_CVHiLim limits in the PPID instruction, there is a general status Sts_CVClamped when CV from any source is clamped. The input value that is used for PIDE must be scaled from % to CVEU to be used in the PPID instruction.</p> <p>For more information, see Differences In Control Variable Related Inputs on page 259.</p>

Table 25 - Equivalent Input Parameters - PIDE Instruction and PPID Instruction (Continued)

PIDE Instruction			PPID Instruction		Comment
Parameter	Data Type	Description	Parameter	Description	
CVOverride	REAL	CV override value. CV equals this value when in override mode. This value should correspond to a safe state output of the PID loop. If CVOverride < 0 or >100, the instruction sets the appropriate bit in Status and limits the CV value. Valid = 0.0...100.0 Default = 0.0	Inp_OvrCV	Loop Manual CV in Override (CVEU). Valid any float. Default is 0.0.	<p>The tag description contains differences in units and valid range.</p> <ul style="list-style-type: none"> • PIDE: <ul style="list-style-type: none"> - Uses percent - Valid = 0.0...100.0 • PPID: <ul style="list-style-type: none"> - Has CVEU - Valid any float <p>There is no status set in the PPID instruction when Inp_OvrCV is outside Cfg_CVEUMin and Cfg_CVEUMax limits (these correspond to PIDE 0% and 100%). There is a difference in clamping, Inp_OvrCV is clamped between Cfg_CVLoLim and Cfg_CVHiLim limits in the PPID instruction if Cfg_SkipManLim is set to 0, while it is never clamped in the PIDE instruction.</p> <p>The input value that is used for PIDE must be scaled from % to CVEU to be used in the PPID instruction.</p> <p>For more information, see Differences in Override on page 259.</p>
CVPrevious	REAL	CV _{n-1} value. If CVSetPrevious is set, CV _{n-1} equals this value. CV _{n-1} is the value of CV from the previous execution. CVPrevious is ignored when in manual, override, or hand mode or when CVInitializing is set. If CVPrevious < 0 or > 100, or < CVLLimit or > CVHLimit when in Auto or cascade/ratio mode, the instruction sets the appropriate bit in Status and limits the CV _{n-1} value. Valid = 0.0...100.0 Default = 0.0	Inp_CVPrev	Previous scan CV, Val_CVOut (CVEU). Valid any float between Cfg_CVEUMin and Cfg_CVEUMax. Default is 0.0	<p>The tag description contains differences in units and valid range.</p> <ul style="list-style-type: none"> • PIDE: <ul style="list-style-type: none"> - Uses percent - Valid = 0.0...100.0 • PPID: <ul style="list-style-type: none"> - Has CVEU - Valid any float between Cfg_CVEUMin...Cfg_CVEUMax. <p>The input value that is used for PIDE must be scaled from % to CVEU to be used in the PPID instruction.</p> <p>For more information, see Differences In Control Variable Related Inputs on page 259.</p>
CVSetPrevious	BOOL	Request to use CVPrevious. If true, CV _{n-1} = CVPrevious Default is false.	Inp_UseCVPrev	1 = Use Inp_CVPrev as previous CV value, 0 = Use last scan value. Default is false	—

Table 25 - Equivalent Input Parameters - PIDE Instruction and PPID Instruction (Continued)

PIDE Instruction			PPID Instruction		Comment
Parameter	Data Type	Description	Parameter	Description	
CVManLimiting	BOOL	Limit CV in manual mode request. If Manual mode and CVManLimiting are true, CV is limited by the CVHLimit and CVLLimit values. Default is false.	Cfg_SkipCVManLim	1 = Skip CV clamping in Manual loop mode and for CV from shed 0 = Always apply CV clamping.	CV limiting in manual mode in the PIDE instruction is functionally opposite of CV manual limiting in the PPID instruction. There is a difference in default value, which means the default setting of CV manual limiting is the same and CV manual limiting is skipped by default.
			Cfg_SkipCVManRoC	1 = Skip CV rate-of-change limiting in Manual loop mode and for CV from shed 0 = Always apply CV rate-of-change limiting.	CVManLimiting configuration parameter is also used to configure CV rate of change limiting in manual mode in the PIDE instruction. In the PPID, there is a dedicated Cfg_SkipCVManRoC parameter. This parameter has also inverse function.
CVEUMax	REAL	Maximum value for CVEU. The value of CVEU, which corresponds to 100 percent CV. If CVEUMax = CVEUMin, the instruction sets the appropriate bit in Status. Valid = any float Default = 100.0	Cfg_CVEUMax	CV maximum value for scaling from % to engineering units (CVEU). Valid any float > Cfg_CVEUMin.	There is a difference in valid range: <ul style="list-style-type: none"> • PIDE: Valid = any float • PPID: Valid any float > Cfg_CVEUMin. This means that it is not possible in the PPID instruction to have Cfg_CVEUMin > Cfg_CVEUMax. For more information, see Differences in Control Variable Scaling and Limits Configuration on page 266 .
CVEUMin	REAL	Minimum value of CVEU. The value of CVEU, which corresponds to 0 percent CV. If CVEUMax = CVEUMin, the instruction sets the appropriate bit in Status. Valid = any float Default = 0.0	Cfg_CVEUMin	CV minimum value for scaling from % to engineering units (CVEU). Valid any float < Cfg_CVEUMax. Default is 0.0	There is a difference in valid range: <ul style="list-style-type: none"> • PIDE: Valid = any float • PPID: Valid any float > Cfg_CVEUMin. This means that it is not possible in the PPID instruction to have Cfg_CVEUMin > Cfg_CVEUMax. For more information, see Differences in Control Variable Scaling and Limits Configuration on page 266 .
CVHLimit	REAL	CV high limit value. This is used to set the CVHAlarm output. It is also used for limiting CV when in Auto or Cascade/Ratio mode, or Manual mode if CVManLimiting is true. If CVHLimit > 100 or < CVLLimit, the instruction sets the appropriate bit in Status. If CVHLimit < CVLLimit, the instruction limits CV using the value of CVLLimit. Valid = CVLLimit < CVHLimit ≤ 100.0 Default = 100.0	Cfg_CVHiLim	Maximum allowed CV value (CVEU). Valid any float ≥ to Cfg_CVLoLim and ≤ Cfg_CVEUMax. Default is 100.0	There is a difference in units and valid range: <ul style="list-style-type: none"> • PIDE: <ul style="list-style-type: none"> - Uses percent - Valid = CVLLimit < CVHLimit ≤ 100.0 • PPID: <ul style="list-style-type: none"> - Uses CVEU - Valid = any float ≥ Cfg_CVLoLim and ≤ Cfg_CVEUMax. There is a difference in CV limits error if Cfg_CVHiLim < Cfg_CVLoLim: <ul style="list-style-type: none"> • PIDE: Limits CV using CVLLimit and no error is set • PPID: Sets Sts_ErrCVLim The input value that is used for PIDE must be scaled from % to CVEU to use in the PPID instruction. For more information, see Differences in Control Variable Scaling and Limits Configuration on page 266 .

Table 25 - Equivalent Input Parameters - PIDE Instruction and PPID Instruction (Continued)

PIDE Instruction			PPID Instruction		Comment
Parameter	Data Type	Description	Parameter	Description	
CVLLimit	REAL	CV low limit value. This is used to set the CVLAlarm output. It is also used for limiting CV when in Auto or Cascade/Ratio mode, or Manual mode if CVManLimiting is true. If CVLLimit < 0 or CVHLimit < CVLLimit, the instruction sets the appropriate bit in Status. If CVHLimit < CVLLimit, the instruction limits CV using the value of CVLLimit. Valid = 0.0 ≤ CVLLimit < CVHLimit Default = 0.0	Cfg_CVLoLim	Minimum allowed CV value (CVEU). Valid any float ≤ Cfg_CVHiLim and ≥ Cfg_CVEUMin. Default is 0.0	<p>There is a difference in units and valid range:</p> <ul style="list-style-type: none"> PIDE: <ul style="list-style-type: none"> Use percent Valid = 0.0 ≤ CVLLimit < CVHLimit PPID: <ul style="list-style-type: none"> Uses CVEU Valid = Any float ≤ Cfg_CVHiLim and ≥ Cfg_CVEUMin. <p>There is a difference in CV limits error if Cfg_CVHiLim < Cfg_CVLoLim.</p> <ul style="list-style-type: none"> PIDE: Limits CV using CVLLimit and no error is set PPID: Sets Sts_ErrCVLim <p>The input value used for PIDE must be scaled from % to CVEU to use in the PPID instruction. For more information, see Differences in Control Variable Scaling and Limits Configuration on page 266</p>
CVROCLimit	Real	CV rate of change limit, in percent per second. Rate of change limiting is only used when in Auto or Cascade/Ratio modes or Manual mode if CVManLimiting is true. Enter 0 to disable CV ROC limiting. If CVROCLimit < 0, the instruction sets the appropriate bit in Status and disables CV ROC limiting. Valid = 0.0 to maximum positive float Default = 0.0	Cfg_CVRoCIncrLim	Maximum allowed CV rate of change increasing value (CVEU/second). The CV rate of change is unlimited when increasing if Cfg_CVRoCIncrLim = 0.0 Valid = 0.0 to maximum positive float. Default is 0.0.	<p>PPID has 2 different parameters for limiting increasing and decreasing rate of change Cfg_CVRoCIncrLim and Cfg_CVRoCDecrLim.</p> <p>There is a difference in units:</p> <ul style="list-style-type: none"> PIDE: Uses percent PPID: Uses CVEU <p>There is a special parameter in the PPID instruction for switching CV rate of change limiting in manual mode Cfg_SkipCVManRoC. PIDE controls both CV value and rate of change limiting in manual mode using one parameter CVManLimiting.</p> <p>The input value used for PIDE must be scaled from % to CVEU in order to be used in the PPID instruction. For more information, see Control Variable Rate of Change Limiting on page 256.</p>
			Cfg_CVRoCDecrLim	Maximum allowed CV rate of change decreasing value (CVEU/second). The CV rate of change is unlimited when decreasing if Cfg_CVRoCDecrLim = 0.0. Valid = 0.0 to maximum positive float. Default is 0.0.	
FF	REAL	Feed forward value. The value of feed forward is summed with CV after the zero-crossing deadband limiting has been applied to CV. Therefore changes in FF are always reflected in the final output value of CV. If FF < -100 or > 100, the instruction sets the appropriate bit in Status and limits the value used for FF. Valid = -100.0...100.0 Default = 0.0	Inp_FF	FeedForward term (CVEU). Valid any float between -(Cfg_CVEUMax-Cfg_CVEUMin) and (Cfg_CVEUMax-Cfg_CVEUMin). Default is 0.0	<p>There are differences in units and valid range.</p> <ul style="list-style-type: none"> PIDE: <ul style="list-style-type: none"> Uses percent Valid = -100.0...100.0 PPID: <ul style="list-style-type: none"> Uses CVEU Valid any float between -(Cfg_CVEUMax-Cfg_CVEUMin) and (Cfg_CVEUMax-Cfg_CVEUMin). <p>The input value that is used for PIDE must be scaled from % to CVEU to use in the PPID instruction. For more information, see Differences In Control Variable Related Inputs on page 259.</p>

Table 25 - Equivalent Input Parameters - PIDE Instruction and PPID Instruction (Continued)

PIDE Instruction			PPID Instruction		Comment
Parameter	Data Type	Description	Parameter	Description	
FFPrevious	REAL	FF _{n-1} value. If FF SetPrevious is set, the instruction sets FF _{n-1} = FFPrevious. FF _{n-1} is the value of FF from the previous execution. If FFPrevious < -100 or > 100, the instruction sets the appropriate bit in Status and limits value that is used for FF _{n-1} . Valid = -100.0...100.0 Default = 0.0	Inp_FFPrev	Previous scan FeedForward (CVEU) when Inp_UseFFPrev = 1. Valid any float between -(Cfg_CVEUMax-Cfg_CVEUMin) and (Cfg_CVEUMax-Cfg_CVEUMin). Default is 0.0	There are differences in units and valid range. • PIDE: - Uses percent - Valid = -100.0...100.0 • PPID: - Uses CVEU - Valid = Any float between -(Cfg_CVEUMax-Cfg_CVEUMin) and (Cfg_CVEUMax-Cfg_CVEUMin). The input value that is used for PIDE must be scaled from % to CVEU to use in the PPID instruction. For more information, see Differences In Control Variable Related Inputs on page 259 .
FFSetPrevious	BOOL	Request to use FFPrevious. If true, FF _{n-1} = FFPrevious. Default is false.	Inp_UseFFPrev	1 = Use Inp_FFPrev as previous FF value, 0 = Use last scan Inp_FF value as previous FF value. Default is false.	—
HandFB	REAL	CV Hand feedback value. CV equals this value when in Hand mode and HandFBFault is false (good health). This value typically comes from the output of a field mounted hand/ auto station and is used to generate a bumpless transfer out of hand mode. If HandFB < 0 or > 100, the instruction sets the appropriate bit in Status and limits the value that is used for CV. Valid = 0.0...100.0 Default = 0.0	Inp_HandFdbk	CV feedback used when owner is Hand (CVEU). Valid = Any float. Default is 0.0.	There are differences in units and valid range. • PIDE: - Uses percent - Valid = -100.0...100.0 • PPID: - Uses CVEU - Valid = any float. The value is limited between Cfg_CVEUMin and Cfg_CVEUMax in the PPID instruction. There is no status set in the PPID instruction when Inp_HandFdbk is outside this range. The input value that is used for PIDE must be scaled from % to CVEU to use in the PPID instruction. For more information, see Differences In Control Variable Related Inputs on page 259 .
HandFBFault	BOOL	HandFB value bad health indicator. If the HandFB value is read from an analog input, then HandFBFault is typically controlled by the status of the analog input channel. When true, HandFBFault indicates an error on the input module and the instruction sets the appropriate bit in Status. Default is false = good health	Inp_HandFdbkBad	1 = CV hand feedback quality or CV hand feedback I/O communications status bad, 0 = OK. Default is false.	—
WindupHIn	BOOL	Windup high request. When true, the CV cannot integrate in a positive direction. The signal is typically obtained from the WindupHOut output from a secondary loop. Default is false.	Inp_WindupHi	Windup high signal. When true, the CV cannot integrate in a positive direction. The signal is typically obtained from the Windup hi output from an inner loop. Default is false.	—

Table 25 - Equivalent Input Parameters - PIDE Instruction and PPID Instruction (Continued)

PIDE Instruction			PPID Instruction		Comment
Parameter	Data Type	Description	Parameter	Description	
WindupLIn	BOOL	Windup low request. When true, the CV cannot integrate in a negative direction. This signal is typically obtained from the WindupLOut output from a secondary loop. Default is false.	Inp_WindupLo	Windup low signal. When true, the CV cannot integrate in a negative direction. The signal is typically obtained from the Windup low output from an inner loop. Default is false.	—
ControlAction	BOOL	Control action request. Set to true to calculate error as $E = PV - SP$; clear to false to calculate error as $E = SP - PV$. Default is false.	Cfg_CtrlAction	1 = Control action on $E = PV - SP$, direct action 0 = Control action on $E = SP - PV$, reverse action. Default is false.	—
DependInpenden d	BOOL	Dependent/independent control request. When true, use the dependent form of the PID equation; when false, use the independent form of the equations. Default is false.	Cfg_Dependent	1 = Dependent gains equation, 0 = Independent gains equation. Default is false.	—
PGain	REAL	Proportional gain. When the independent form of the PID algorithm is selected, enter the unitless proportional gain into this value. When the dependent PID algorithm is selected, enter the unitless controller gain into this value. Enter 0 to disable the proportional control. If $PGain < 0$, the instruction sets the appropriate bit in Status and uses a value of $PGain = 0$. Valid = 0.0 to maximum positive float. Default = 0.0	Cfg_PGain	Proportional gain K_p for independent gains or loop gain K_c for dependent gains (unitless). Valid = 0.0 to maximum positive float. Default is 0.0.	The are difference between instructions is that in case of $PGain < 0$: <ul style="list-style-type: none"> • PIDE: <ul style="list-style-type: none"> - Uses $PGain = 0$ - Computes PID algorithm with this setting • PPID: <ul style="list-style-type: none"> - Sets CV fail status - Applies configured CV fail actions For more information, see the PPID instruction online help.
IGain	REAL	Integral gain. When the independent form of the PID algorithm is selected, enter the integral gain in units of 1/minutes into this value. When the dependent PID algorithm is selected, enter the integral time constant in units of minutes/repeat into this value. Enter 0 to disable the integral control. If $IGain < 0$, the instruction sets the appropriate bit in Status and uses a value of $IGain = 0$. Valid = 0.0 to maximum positive float. Default = 0.0	Cfg_IGain	Integral gain K_i (1/minute) for independent or reset time T_i (minutes/repeat) for dependent gains. Valid = 0.0 to maximum positive float. Default is 0.0.	The difference is that in case of $IGain < 0$: <ul style="list-style-type: none"> • PIDE: <ul style="list-style-type: none"> - Uses $IGain = 0$ - Computes PID algorithm with this setting • PPID: <ul style="list-style-type: none"> - Sets CV fail status - Applies configured CV fail actions. For more information, see the PPID instruction online help.
DGain	REAL	Derivative gain. When the independent form of the PID algorithm is selected, enter the derivative gain in units of minutes into this value. When the dependent PID algorithm is used, enter the derivative time constant in units of minutes into this value. Enter 0 to disable the derivative control. If $DGain < 0$, the instruction sets the appropriate bit in Status and uses a value of $DGain = 0$. Valid = 0.0 to maximum positive float. Default = 0.0	Cfg_DGain	Derivative gain K_d (minute) for independent or rate time T_d (minute) for dependent gains. Valid = 0.0 to maximum positive float. Default is 0.0.	The difference is that in case of $DGain < 0$: <ul style="list-style-type: none"> • PIDE: <ul style="list-style-type: none"> - Uses $DGain = 0$ - Computes PID algorithm with this setting • PPID: <ul style="list-style-type: none"> - Sets CV fail status - Applies configured CV fail actions For more information, see the PPID instruction online help.
DSmoothing	BOOL	Derivative Smoothing request. When true, changes in the derivative term are smoothed. Derivative smoothing causes less output "jitters" as a result of a noisy PV signal but also limits the effectiveness of high derivative gains. Default is false.	Cfg_UseDSmoothing	1 = Use derivative smoothing. Default is false.	—
PVTracking	BOOL	SP track PV request. Set to true to cause SP to track PV when in manual mode. Ignored when in Cascade/Ratio or Auto mode. Default is false.	Cfg_PVTrack	1 = SP tracks PV in Manual 0 = No PV tracking. Default is false.	—

Table 25 - Equivalent Input Parameters - PIDE Instruction and PPID Instruction (Continued)

PIDE Instruction			PPID Instruction		Comment
Parameter	Data Type	Description	Parameter	Description	
DevHHLimit	REAL	Deviation high-high alarm limit value, scaled in PV units. Deviation is the difference in value between the PV and the SP. Deviation alarming alerts the operator to a discrepancy between the process variable and the setpoint value. If DevHHLimit < 0.0, the instruction sets the appropriate bits in Status and sets DevHHLimit = 0.0. Valid = 0.0 to maximum positive float Default = maximum positive float	Cfg_HiHiDevLim	High-High PV deviation status threshold (PVEU). Valid = 0.0 to maximum positive float. Default is 1.5e+38.	There is a difference in default value. <ul style="list-style-type: none"> PIDE: Default = Maximum positive float PPID = Default is 1.5e+38. There is difference in action if Cfg_HiHiDevLim < 0.0. PIDE sets the limit to 0.0 in this case, while PPID continues to operate with the negative value.
DevHLimit	REAL	Deviation high alarm limit value, scaled in PV units. Deviation is the difference in value between the PV and the SP. Deviation alarming alerts the operator to a discrepancy between the process variable and the setpoint value. If DevHLimit < 0.0, the instruction sets the appropriate bit in Status and sets DevHLimit = 0.0. Valid = 0.0 to maximum positive float Default = maximum positive float	Cfg_HiDevLim	High PV deviation status threshold (PVEU). Valid = 0.0 to maximum positive float. Default is 1.5e+38.	There is a difference in default value. <ul style="list-style-type: none"> PIDE: Default = Maximum positive float PPID: Default is 1.5e+38. There is difference in action if Cfg_HiDevLim < 0.0. PIDE sets the limit to 0.0 in this case, while PPID continues to operate with the negative value.
DevLLimit	REAL	Deviation low alarm limit value, scaled in PV units. Deviation is the difference in value between the PV and the SP. Deviation alarming alerts the operator to a discrepancy between the process variable and the setpoint value. If DevLLimit < 0.0, the instruction sets the appropriate bit in Status and sets DevLLimit = 0.0. Valid = 0.0 to maximum positive float Default = maximum positive float	Cfg_LoDevLim	Low PV deviation status threshold (PVEU). Valid = -maximum positive float to 0.0. Default is -1.5e+38.	There are differences in valid range and default values: <ul style="list-style-type: none"> PIDE: <ul style="list-style-type: none"> Valid = 0.0...Maximum positive float Default = Maximum positive float PPID: <ul style="list-style-type: none"> Valid range = Maximum positive float...0.0. Default is -1.5e+38. There is difference in action if Cfg_LoDevLim > 0.0 (equivalent to DevLLimit < 0.0 in the PIDE instruction). PIDE sets the limit to 0.0 in this case, while PPID continues to operate with the positive value.
DevLLLimit	REAL	Deviation low-low alarm limit value, which is scaled in PV units. Deviation is the difference in value between the PV and the SP. Deviation alarming alerts the operator to a discrepancy between the process variable and the setpoint value. If DevLLLimit < 0.0, the instruction sets the appropriate bit in Status and sets DevLLLimit = 0.0. Valid = 0.0 to maximum positive float Default = maximum positive float	Cfg_LoLoDevLim	Low-Low PV deviation status threshold (PVEU). Valid = -maximum positive float to 0.0. Default is -1.5e+38.	There are differences in valid range and default values: <ul style="list-style-type: none"> PIDE: <ul style="list-style-type: none"> Valid range = 0.0...Maximum positive float Default = Maximum positive PPID: <ul style="list-style-type: none"> Valid range = Maximum positive float...0.0 Default is -1.5e+38 There is difference in action if Cfg_LoDevLim > 0.0 (equivalent to DevLLimit < 0.0 in the PIDE instruction). PIDE sets the limit to 0.0 in this case, while PPID continues to operate with the positive value.

Table 25 - Equivalent Input Parameters - PIDE Instruction and PPID Instruction (Continued)

PIDE Instruction			PPID Instruction		Comment
Parameter	Data Type	Description	Parameter	Description	
DevDeadband	REAL	The deadband value for the Deviation alarm limits, which are scaled in PV units. Deadband is the delta value between the turn-on and turn-off value for each of the Deviation alarm limits. If DevDeadband < 0.0, the instruction sets the appropriate bit in Status and sets DevDeadband = 0.0. Valid = 0.0 to maximum positive float Default = 0.0	Cfg_HiHiDevDB	High-High PV deviation status deadband (PVEU). Valid = 0.0 to Cfg_HiHiDevLim. Default is 0.0.	Each deviation alarm in the PPID instruction has its own deadband configuration parameter. The tag description contains difference in valid range: <ul style="list-style-type: none"> • PIDE: Valid range = 0.0...Maximum positive float • PPID: Valid range = 0.0...Corresponding limit absolute value
			Cfg_HiDevDB	High PV deviation status deadband (PVEU). Valid = 0.0 to Cfg_HiDevLim. Default is 0.0.	
			Cfg_LoDevDB	Low PV deviation status deadband (PVEU). Valid = 0.0 to abs (Cfg_LoDevLim). Default is 0.0.	
			Cfg_LoLoDevDB	Low-Low PV deviation status deadband (PVEU). Valid = 0.0 to abs (Cfg_LoLoDevLim). Default is 0.0.	
AllowCasRat	BOOL	Allow cascade/ratio mode permissive. Set to true to allow Cascade/Ratio mode to be selected using either ProgCasRatReq or OperCasRatReq. Default is false.	Cfg_HasCasc	1 = Enable the loop to be placed into Cascade/Ratio mode. Default is false.	—
ManualAfterInit	BOOL	Manual mode after initialization request. When true, the instruction is placed in Manual mode when CVinitializing is true, unless the current mode is Override or Hand. When ManualAfterInit is false, the instruction's mode is not changed, unless requested to do so. Default is false.	Cfg_InitializeToMan	1 = Go to Manual loop mode when initialization is requested (Inp_UseCVInitialVal=1). Default is false.	Command source works differently in the PPID instruction, Manual mode is switched on independently of Override or Hand.
ProgProgReq	BOOL	Program program request. Set to true by the user program to request Program control. Ignored if ProgOperReq is true. Holding this true and ProgOperReq false locks the instruction in Program control. When ProgValueReset is true, the instruction clears this input to false at each execution. Default is false.	PCmd_Prog	Program command to select Program (Operator to Program). The instruction clears this operand automatically. Default is false.	There is a difference in ProgProgReq and ProgOperReq priority in the PIDE instruction vs PCmd_Prog and PCmd_Oper priority in the PPID instruction. <ul style="list-style-type: none"> • PIDE: ProgOperReq wins • PPID: PCmd_Prog wins PPID has a command PCmd_Lock for locking the instruction in program control. There is a difference in clearing of the parameter. PIDE clears or does not clear in each scan based on ProgValueReset parameter value. PPID always clears the input parameter in each scan.

Table 25 - Equivalent Input Parameters - PIDE Instruction and PPID Instruction (Continued)

PIDE Instruction			PPID Instruction		Comment
Parameter	Data Type	Description	Parameter	Description	
ProgOperReq	BOOL	Program operator request. Set to true by the user program to request Operator control. Holding this true locks the instruction in Operator control. When ProgValueReset is true, the instruction clears this input to false at each execution. Default is false.	PCmd_Oper	Program command to select Operator (Program to Operator). The instruction clears this operand automatically. Default is false.	<p>The tag description contains a difference in clearing of the parameter:</p> <ul style="list-style-type: none"> • PIDE: Clears or does not clear in each scan based on ProgValueReset parameter value. • PPID: Always clears the input parameter in each scan.
ProgCasRatReq	BOOL	Program cascade/ratio mode request. Set to true by the user program to request Cascade/Ratio mode. When ProgValueReset is true, the instruction clears this input to false at each execution. Default is false.	PCmd_Casc	Program command to select Cascade/Ratio loop mode. The instruction clears this operand automatically. Default is false.	
ProgAutoReq	BOOL	Program auto mode request. Set to true by the user program to request Auto mode. When ProgValueReset is true, the instruction clears this input to false at each execution. Default is false.	PCmd_Auto	Program command to select Auto loop mode. The instruction clears this operand automatically. Default is false.	
ProgManualReq	BOOL	Program manual mode request. Set to true by the user program to request Manual mode. When ProgValueReset is true, the instruction clears this input to false. Default is false.	PCmd_Man	Program command to select Manual loop mode. The instruction clears this operand automatically. Default is false.	
ProgOverrideReq	BOOL	Program override mode request. Set to true by the user program to request Override mode. When ProgValueReset is true, the instruction clears this input to false at each execution. Default is false.	Inp_Ovrd	1 = Acquire Override (higher priority program logic) 0 = Release Override. Default is false.	<p>PIDE uses this parameter as request to acquire Override, and when the parameter is false, the instruction stays in Override mode until next request.</p> <p>PPID uses Override input as level, which means that if set to true, Override is requested in each scan, and when false, Override is released in each scan.</p> <p>For more information, see Differences in Override on page 259.</p>
ProgHandReq	BOOL	Program hand mode request. Set to true by the user program to request Hand mode. This value is usually read as a digital input from a hand/auto station. When ProgValueReset is true, the instruction clears this input to false at each execution. Default is false.	Inp_Hand	1 = Acquire Hand 0 = Release Hand Default is false.	<p>PIDE uses this parameter as request to acquire Hand, and when the parameter is false, the instruction stays in Hand mode until next request.</p> <p>PPID uses Hand input as level, which means that if set to true, Hand is requested in each scan, and when false, Hand is released in each scan.</p>

Alternative Input Parameters

The following table describes input parameters in the PIDE instruction for which there are alternative input parameters in the PPID instruction that you can use.

Table 26 - Alternative Input Parameters - PIDE Instruction and PPID Instruction

PIDE Instruction			PPID Instruction		Comment
Parameter	Data Type	Description	Parameter	Description	
PVEProportional	BOOL	Proportional PV control request. When true, calculate the proportional term (DeltaPTerm) using the change in process variable (PVPercent). When false, use the change in error (EPercent). Default is false.	Cfg_PSPWeight	Weight on SP in proportional term in 2DOF PID, beta gain. Valid = 0.0...1.5 Default is 1.0.	PPID uses 2DOF PID algorithm and weight on SP in proportional term is configured using Cfg_PSPWeight parameter which is a REAL data type. Setting Cfg_PSPWeight = 1.0 is equivalent to PVEProportional=True. Cfg_PSPWeight = 0.0 is equivalent to PVEProportional = False
PVEDerivative	BOOL	Derivative PV control request. When true, calculate the derivative term (DeltaDTerm) using the change in process variable (PVPercent). When false, use the change in error (EPercent). Default is true.	Cfg_DSPWeight	Weight on SP in derivative term in 2DOF PID, gamma gain. Valid = 0.0...1.5 Default is 0.0.	PPID uses 2DOF PID algorithm and weight on SP in derivative term is configured using Cfg_DSPWeight parameter which is a REAL data type. Setting Cfg_DSPWeight = 1.0 is equivalent to PVEDerivative = True. Cfg_DSPWeight = 0.0 is equivalent to PVEDerivative = False
ZCDeadband	REAL	Zero crossing deadband range scaled in PV units. Defines the zero crossing deadband range. Enter 0 to disable the zero crossing deadband checking. If ZCDeadband < 0, the instruction sets the appropriate bit in Status and disables zero crossing deadband checking. Valid = 0.0 to maximum positive float Default = 0.0	Cfg_DevDB	PV deviation deadband for PV going away from SP (PVEU). Valid = 0.0 to maximum positive float.	The PIDE instruction uses the Zero Crossing deadband. The PPID instruction uses the PV deviation deadband instead. For more information, see Zero Crossing Deadband and Process Variable Deviation Deadband on page 254 .
ZCoff	BOOL	Zero crossing disable request. Set to true to disable zero crossing for the deadband calculation. Default is false.	Cfg_DevDBEnter	PV deviation deadband for PV approaching SP (PVEU). Valid = 0.0 to Cfg_DevDB.	

Equivalent or Alternative Input Parameters

The following table describes input parameters that can be used as follows between PIDE and PPID instructions:

- If the PIDE instruction parameter is used one way, the new parameter in the PPID instruction can be used the same.
- If the parameter is used another way, then an alternative approach in the PPID instruction must be used. This is typical for the operator inputs or commands - if they are currently set from HMI and not accessed via Logix Designer, the operator commands of PPID can be used instead.

If they are connected to other tags in Logix Designer, then an alternative must be used, for example, external commands.

Table 27 - Equivalent/Alternative Input Parameters - PIDE Instruction and PPID Instruction

PIDE Instruction			PPID Instruction		Comment
Parameter	Data Type	Description	Parameter	Description	
SPOper	REAL	SP operator value, scaled in PV units. SP is set to this value when in Operator control and not Cascade/Ratio mode. If the value of SPOper < SPLLimit or > SPHLimit, the instruction sets the appropriate bit in Status and limits the value that is used for SP. Valid = SPLLimit to SPHLimit Default = 0.0	OSet_SP	Operator setting for Setpoint, loop mode Auto (PVEU). Valid any float. Default is 0.0.	The tag description contains difference in valid range. <ul style="list-style-type: none"> • PIDE valid value = SPLLimit to SPHLimit • PPID valid value is any float. There is no difference in the clamping function, so PPID setpoint is also clamped between Cfg_SPLoLim and Cfg_SPHLim. There is no specific status bit for OSet_SP outside the setpoint limits in the PPID instruction, there is a general status Sts_SPClamped when setpoint from any source is clamped. OSet_SP is a local tag member; it is not available to be used in Logix Designer application. For more information, see Differences in Operator Mode on page 262 .
RatioOper	REAL	Ratio operator multiplier. Ratio is set equals this value when in Operator control. If RatioOper < RatioLLimit or > RatioHLimit, the instruction sets the appropriate bit in Status and limits the value that is used for Ratio. Valid = RatioLLimit to RatioHLimit Default = 1.0	OSet_Ratio	Operator setting for Ratio, loop mode Cascade/Ratio and Ratio enabled (unitless). Valid = 0.0 to maximum positive float. Default is 1.0.	The tag description contains difference in valid range. <ul style="list-style-type: none"> • PIDE valid value = RatioLLimit to RatioHLimit • PPID valid is 0.0 to maximum positive float. There is no difference in the clamping function, so PPID ratio is also clamped between Cfg_RatioLoLim and Cfg_RatioHiLim. There is no specific status bit for OSet_Ratio outside the ratio limits in the PPID instruction, there is a general status Sts_RatioClamped when ratio from any source is clamped. OSet_Ratio is a local tag member, it is not available to be used in Logix Designer application. For more information, see Differences in Operator Mode on page 262 .
CVInitReq	BOOL	CV initialization request. This signal is normally controlled by the "In Hold" status on the analog output module controlled by CVEU or from the InitPrimary output of a secondary PID loop. Default is false.	Inp_UseCVInitialVal	1 = Initialize CV to Inp_CVInitialVal Default is false	Inp_UseCVInitialVal is used identically for CV initialization. In the PPID instruction, there is a different recommended way of connecting primary and secondary loop using Sts_CascAvailable and Inp_InnerAvailable. For more information, see Differences in Cascade on page 265 .

Table 27 - Equivalent/Alternative Input Parameters - PIDE Instruction and PPID Instruction (Continued)

PIDE Instruction			PPID Instruction		Comment
Parameter	Data Type	Description	Parameter	Description	
CVInitVal	REAL	CVEU initialization value, scaled in CVEU units. When CVinitializing is true, CVEU = CVInitValue and CV equals the corresponding percentage value. CVInitValue comes from the feedback of the analog output controlled by CVEU or from the setpoint of a secondary loop. Instruction initialization is disabled when CVFaulted or CVEUSpanInv is true. Valid = any float Default = 0.0	Inp_CVInitialVal	Value to initialize the CV to per request Inp_UseCVInitialVal=1 (CVEU). Valid any float. Default is 0.0	Inp_CVInitialVal is used identically for CV initialization. In the PPID instruction, there is a different recommended pin for setpoint of a secondary loop Inp_CVTrack. For more information, see Differences in Cascade on page 265
CVOper	REAL	CV operator manual value. CV equals this value when in Operator Manual mode. If not Operator Manual mode, the instruction sets CVOper = CV at the end of each instruction execution. If CVOper < 0 or > 100, or < CVLLimit or > CVHLimit when CVManLimiting is true, the instruction sets the appropriate bit in Status and limits the CV value. Valid = 0.0...100.0 Default = 0.0	OSet_CV	Operator setting for CV, loop mode Manual (CVEU). Valid any float. Default is 0.0	The tag description contains differences in units and valid range. <ul style="list-style-type: none"> • PIDE uses percent and valid values = 0.0...100.0 • PPID has CVEU and valid values are any float. There is no status set in the PPID instruction when OSet_CV is outside Cfg_CVEUMin and Cfg_CVEUMax limits (these correspond to PIDE 0% and 100%). There is no specific status bit for OSet_CV outside the Cfg_CVLoLim and Cfg_CVHiLim limits in the PPID instruction, there is a general status Sts_CVClamped when CV from any source is clamped. OSet_CV is a local tag member, it is not available to be used in Logix Designer application. For a workaround, see Differences in Operator Mode on page 262 . The input value that is used for PIDE must be scaled from % to CVEU to use in the PPID instruction. For more information, see Differences In Control Variable Related Inputs on page 259 .
OperProgReq	BOOL	Operator program request. Set to true by the operator interface to request Program control. The instruction clears this input to false at each execution. Default is false.	OCmd_Prog	Operator command to select Program (Operator to Program). The instruction clears this operand automatically. Default is 0.	Operator commands are local tag members in the PPID instruction. They are not available to use in Logix Designer application. For more information, see Differences in Operator Mode on page 262 .
OperOperReq	BOOL	Operator operator request. Set to true by the operator interface to request Operator control. The instruction clears this input to false at each execution. Default is false.	OCmd_Oper	Operator command to select Operator (Program to Operator). The instruction clears this operand automatically. Default is 0.	
OperCasRatReq	BOOL	Operator cascade/ratio mode request. Set to true by the operator interface to request Cascade/ Ratio mode. The instruction clears this input to false at each execution. Default is false.	OCmd_Casc	Operator command to select Cascade/ Ratio loop mode. The instruction clears this operand automatically. Default is 0.	
OperAutoReq	BOOL	Operator auto mode request. Set to true by the operator interface to request Auto mode. The instruction clears this input to false at each execution. Default is false.	OCmd_Auto	Operator command to select Automatic loop mode. The instruction clears this operand automatically. Default is 0.	
OperManualReq	BOOL	Operator manual mode request. Set to true by the operator interface to request Manual mode. The instruction clears this input to false at each execution. Default is false.	OCmd_Man	Operator command to select Manual loop mode. The instruction clears this operand automatically. Default is 0.	

No Equivalent Input Parameters

The following table describes input parameters in the PIDE instruction that have no equivalent in the PPID instruction.

Table 28 - No Equivalent Input Parameters - PIDE Instruction and PPID Instruction

PIDE Instruction			Comment
Parameter	Data Type	Description	
ProgValueReset	BOOL	Reset program control values. When true, all program request inputs are cleared to false by the instruction at each execution. When true and in Operator control, the instruction sets SPProgram = SP and CVProgram = CV. Default is false.	There is no configuration parameter for turning clearing of program command parameters on and off in the PPID instruction, they are always cleared, unless Cfg_PCcmdProgAsLevel or Cfg_PCcmdLockAsLevel is set. ProgValueReset also tracks Operator SP and CV values by program inputs. This is configured using the Cfg_SetTrack parameter in the PPID instruction. This setting not only affects tracking the Operator value by Program but also makes sure that the values from active command source are tracked by the inactive ones for Program, Operator and External command sources. Valid values for the Cfg_SetTrack parameter in the PPID instruction are: 1 = Program/Operator/External settings tracking, 0 = No settings tracking. Default is true.
PVHHLimit	REAL	PV high-high alarm limit value, scaled in PV units. Valid = any float Default = maximum positive float	Replaced using tag-based alarms if alarm is needed in HMI. Replaced using external logic if alarm indicator is needed in your application's logic. For more information, see Differences In Alarming on page 248 .
PVHLimit	REAL	PV high alarm limit value, scaled in PV units. Valid = any float Default = maximum positive float	
PVLLimit	REAL	PV low alarm limit value, scaled in PV units. Valid = any float Default = maximum negative float	
PVLLLimit	REAL	PV low-low alarm limit value, scaled in PV units. Valid = any float Default = maximum negative float	
PVDeadband	REAL	PV alarm limit deadband value, scaled in PV units. Deadband is the delta value between the turn-on and turn-off value for each of the PV alarm limits. If PVDeadband < 0.0, the instruction sets the appropriate bit in Status and limits PVDeadband to zero. Valid = 0.0 to maximum positive float Default = 0.0	
PCROCPoSLimit	REAL	PV positive rate of change alarm limit. The limit value for a positive (increasing) change in PV, scaled in PV units per seconds. Enter 0.0 to disable positive PVROC alarm checking. If PVROCPoSLimit < 0.0, the instruction sets the appropriate bit in Status and disables positive PVROC checking. Valid = 0.0 to maximum positive float Default = 0.0 PV/second	
PVROCNegLimit	REAL	PV negative rate of change alarm limit. The limit value for a negative (decreasing) change in PV, scaled in PV units per seconds. Enter 0.0 to disable negative PVROC alarm checking. If PVROCNegLimit < 0, the instruction sets the appropriate bit in Status and disables negative PVROC checking. Valid = 0.0 to maximum positive float Default = 0.0	

Table 28 - No Equivalent Input Parameters - PIDE Instruction and PPID Instruction (Continued)

PIDE Instruction			Comment
Parameter	Data Type	Description	
PVROCPeiod	REAL	PV rate of change sample period. The time period, in seconds, over which the rate of change for PV is evaluated. Enter 0 to disable PVROC alarm checking. If PVROCPeiod < 0.0, the instruction sets the appropriate bit in Status, and disables positive and negative PVROC checking. Valid = any float ≥ 0.0 Default = 0.0 seconds	This parameter can be used as input of external logic if alarm indicator is needed.
TimingMode	DINT	Selects timing execution mode. 0 = Periodic mode 1 = Oversample mode 2 = Real time sampling mode For more information about timing modes, see Function Block Attributes. Valid = 0..2 Default = 0	In the PPID instruction, only periodic execution mode is available. The execution period of the PID algorithm is configured by using the Cfg_ExecTime tag. <ul style="list-style-type: none"> If the scan time is ≥ to Cfg_ExecTime, the PID algorithm is executed every scan, effectively using the scan time as its execution period. If Cfg_ExecTime is > the scan time, the PID algorithm is executed with the execution interval equal to the time elapsed since its last execution if the elapsed time is greater or equal to Cfg_ExecTime.
OversampleDT	REAL	Execution time for oversample mode. Valid = 0..4194.303 seconds Default = 0	
RTSTime	DINT	Module update period for real time sampling mode Valid = 1..32,767ms Default = 1	
RTTimeStamp	DINT	Module time stamp value for real time sampling mode. Valid = 0..32,767ms Default = 0	This configuration affects only the execution of the PIDE algorithm. Commands and parameter updates are processed on every scan, regardless of the Cfg_ExecTime setting.
AtuneAcquire	BOOL	Acquire PIDE AtuneData request. Default is false.	
AtuneStart	BOOL	Start Autotune request. Default is false.	There is no autotuner built-in functionality available for PPID in Logix Designer application. We recommend that you use third-party tuning software when performing tuning with the PPID instruction.
AtuneUseGains	BOOL	Use Autotune gains request. Default is false.	
AtuneAbort	BOOL	Abort Autotune request. Default is false.	
AtuneUnacquire	BOOL	Unacquire PIDE AtuneData request. Default is false.	

Equivalent Output Parameters

The following table describes the equivalent output parameters between the PIDE instruction and the PPID instruction. The parameters are a one-to-one match when you migrate from the PIDE instruction to the PPID instruction.

Table 29 - Equivalent Output Parameters - PIDE Instruction and PPID Instruction

PIDE Instruction			PPID Instruction		Comment
Parameter	Data Type	Description	PPID Parameter	Description	
EnableOut	BOOL	Indicates if instruction is enabled. Cleared to false if CVEU overflows.	EnableOut	Enable output. This output state always reflects EnableIn input state.	PPID Val_CVOut cannot overflow, so EnableOut always tracks EnableIn.
CVEU	REAL	Scaled control variable output. Scaled using CVEUMax and CVEUMin, where CVEUMax corresponds to 100 percent and CVEUMin corresponds to 0 percent. This output typically controls an analog output module or a secondary loop. $CVEU = (CV \times CVEUSpan/100) + CVEUMin$ CVEU span calculation: $CVEUSpan = (CVEUMax - CVEUMin)$	Val_CVOut	Loop CV after clamping and ramping (CVEU).	—
CV	REAL	Control variable output. This value is expressed as 0 to 100 percent. CV is limited by CVHLimit and CVLLimit when in auto or cascade/ratio mode or manual mode if CVManLimiting is true. Otherwise this value is limited by 0 and 100 percent.	Val_CVOutPercent	Loop CV after ramping and clamping (percent of span).	—
CVInitializing	REAL	Initialization mode indicator. CVInitializing is set to true when CVInitReq is true, during instruction first scan, and on a true to false transition of CVHealth (bad to good). CVInitializing is cleared to false after the instruction has been initialized and CVInitReq is false.	Sts_Initializing	1 = CV is initializing because of request Inp_UseCVInitialVal or when Inp_InnerAvailable=0.	There is a difference in the condition when the status is set. PPID only sets it when Inp_UseCVInitialVal=1. It is not set in the PPID instruction when Inp_InnerAvailable=0, this is an issue in the parameter description.
CVROCArm	BOOL	CV rate of change alarm indicator. Set to true when the calculated rate of change for CV exceeds CVROCLimit.	Sts_CVRamping	1 = CV is ramping toward Val_CVSet, 0 = Ramp complete.	The PPID instruction status Sts_CVRamping is set when rate of change of Val_CVSet is limited by Cfg_CVROcIncrLim or Cfg_CVROcDecrLim, while PPID only uses one parameter CVROCLimit for both directions. There is a difference between the instructions when current CV rate of change is equal to the rate of change limit: <ul style="list-style-type: none"> • PIDE: Sets CVROCArm status (although the parameter description claims that it is set when CVROCLimit is exceeded) • PPID: Clears Sts_CVRamping status
SP	REAL	Current setpoint value. The value of SP is used to control CV when in Auto or Cascade/ Ratio mode.	Val_SP	Value of SP being used after clamping and ramping (PVEU).	—
SPPercent	REAL	The value of SP expressed in percent of span of PV. $SPPercent = ((SP - PVEUMin) \times 100) / PVSpan$ PV Span calculation: $PVSpan = (PVEUMax - PVEUMin)$	Val_SPPercent	Loop SP (percent of span).	—

Table 29 - Equivalent Output Parameters - PIDE Instruction and PPID Instruction (Continued)

PIDE Instruction			PPID Instruction		Comment
Parameter	Data Type	Description	PPID Parameter	Description	
SPHAlarm	BOOL	SP high alarm indicator. Set to true when the SP > SPHLimit.	Sts_SPHiClamped	1 = Selected SP is being clamped at high limit.	The PPID instruction status Sts_SPHiClamped is equivalent to SPHAlarm status in the PIDE instruction. The difference is behavior when there is an exceptional condition. <ul style="list-style-type: none"> • PIDE: SPHAlarm is not evaluated when the SP limits configuration is invalid (SPLimitsInv is set) • PPID: Sts_SPHiClamped is not evaluated if SP is not held by shed (Sts_SPHeld=0), and SP is not set to interlock SP by shed (Sts_IntlkSP=0), and SP clamping limits are valid (Sts_ErrSPLim=0) For more information, see Differences in Alarming on page 248
SPLAlarm	BOOL	SP low alarm indicator. Set to true when the SP < SPLLimit.	Sts_SPLoClamped	1 = Selected SP is being clamped at low limit.	The PPID instruction status Sts_SPLoClamped is equivalent to SPLAlarm status in the PIDE instruction. The difference is behavior when there is an exceptional condition. <ul style="list-style-type: none"> • PIDE: SPLAlarm is not evaluated when the SP limits configuration is invalid (SPLimitsInv is set) • PPID: Sts_SPLoClamped is not evaluated if SP is not held by shed (Sts_SPHeld=0), and SP is not set to interlock SP by shed (Sts_IntlkSP=0), and SP clamping limits are valid (Sts_ErrSPLim=0) For more information, see Differences in Alarming on page 248
PVPercent	REAL	PV expressed in percent of span. $PVPercent = ((PV - PVEUMin) \times 100) / PVSpan$ PV Span calculation: $PVSpan = (PVEUMax - PVEUMin)$	Val_PVPercent	Loop PV (percent of span).	The difference between instructions: <ul style="list-style-type: none"> • PIDE: value can be out of range 0, 100% • PPID: value is clamped to range 0, 100%
E	REAL	Process error. Difference between SP and PV, scaled in PV units.	Val_E	Loop error, SP-PV for reverse action Cfg_CtrlAction = 0, PV-SP for direct action Cfg_CtrlAction = 1 (PVEU).	—
EPercent	REAL	The error expressed as a percent of span.	Val_EPercent	Loop error, SP-PV for reverse action Cfg_CtrlAction = 0, PV-SP for direct action Cfg_CtrlAction = 1 (percent of span).	The difference between instructions: <ul style="list-style-type: none"> • PIDE: value can be out of range - 100%, 100% • PPID: value is clamped to range - 100%, 100%
InitPrimary	BOOL	Initialize primary loop command. Set to true when not in Cascade/Ratio mode or when CVInitializing is true. This signal is normally used by the CVInitReq input of a primary PID loop.	Sts_CascAvailable	1 = PID inner loop is available for cascade control with an outer loop. 0 = PID inner loop is not available, initialize outer loop to Val_SP.	In the PPID instruction, there is a different recommended way of connecting primary and secondary loop using Sts_CascAvailable and Inp_InnerAvailable. Sts_CascAvailable values have inverse meaning compared to InitPrimary output parameter of PIDE. For more information, see Differences in Cascade on page 265 .

Table 29 - Equivalent Output Parameters - PIDE Instruction and PPID Instruction (Continued)

PIDE Instruction			PPID Instruction		Comment
Parameter	Data Type	Description	PPID Parameter	Description	
WindupHOut	BOOL	Windup high indicator. Set to true when CV high or CV low limit (depending on the control action) or SP high limit has been reached. This signal is typically used by the WindupHIn input to prevent the windup of the CV output on a primary loop.	Sts_WindupHi	1 = This loop winding up High, usually connects to Inp_WindupHi of outer loop.	—
WindupLOut	BOOL	Windup low indicator. Set to true when CV high or CV low limit (depending on the control action) or SP low limit has been reached. This signal is typically used by the WindupLIn input to prevent the windup of the CV output on a primary loop.	Sts_WindupLo	1 = This loop winding up Low, usually connects to Inp_WindupLo of outer loop.	—
Ratio	REAL	Current ratio multiplier.	Val_Ratio	Value of loop Ratio (unitless).	The difference between instructions: <ul style="list-style-type: none"> • PIDE: Input ratio is written to the output value in every mode • PPID: Input ratio is written to the output value only in Casc/Ratio mode
DevHHiAlarm	BOOL	Deviation high-high alarm indicator. Set to true when $PV \geq (SP + DevHHLimit)$. Cleared to false when $PV < (SP + DevHHLimit - DevDeadband)$	Sts_HiHiDev	1 = PV deviation > High-High limit, $(Val_{PV} - Val_{SP}) > Cfg_HiHiDevLim$, for gate open. There is a predefined default discrete tag-based alarm for the status. Set standard configuration members of the discrete tag-based alarm. Access alarm elements using this format: <code>PPIDTag.@Alarms.Alm_HiHiDev.AlarmElement</code>	There is a difference in condition triggering the alarm status. <ul style="list-style-type: none"> • PIDE: The deviation \geq the limit • PPID: The deviation > the limit Another difference is that in PPID the status remains set at least for 2.5 seconds for the tag-based alarm and alarm set to be able to process it.
DevHAlarm	BOOL	Deviation high alarm indicator. Set to true when $PV \geq (SP + DevHLimit)$. Cleared to false when $PV < (SP + DevHLimit - DevDeadband)$	Sts_HiDev	1 = PV deviation > High limit, $(Val_{PV} - Val_{SP}) > Cfg_HiDevLim$, for gate open. There is a predefined default discrete tag-based alarm for the status. Set standard configuration members of the discrete tag-based alarm. Access alarm elements using this format: <code>PPIDTag.@Alarms.Alm_HiDev.AlarmElement</code>	
DevLAlarm	BOOL	Deviation low alarm indicator. Set to true when $PV \leq (SP - DevLLimit)$. Cleared to false when $PV > (SP - DevLLimit + DevDeadband)$	Sts_LoDev	1 = PV deviation (loop error) is < Low limit, $(Val_{PV} - Val_{SP}) < Cfg_LoDevLim$, for gate open. There is a predefined default discrete tag-based alarm for the status. Set standard configuration members of the discrete tag-based alarm. Access alarm elements using this format: <code>PPIDTag.@Alarms.Alm_LoDev.AlarmElement</code>	There is a difference in condition triggering the alarm status. <ul style="list-style-type: none"> • PIDE: The deviation \leq the negative of the limit • PPID: The deviation < the limit This is because the limit value in the PIDE instruction is set as positive value, while in the PPID instruction as negative value. Another difference is that in the PPID instruction, the status remains set at least for 2.5 seconds for the tag-based alarm and alarm set to be able to process it.
DevLLAlarm	BOOL	Deviation low-low alarm indicator. Set to true when $PV \leq (SP - DevLLLimit)$. Cleared to false when $PV > (SP - DevLLLimit + DevDeadband)$	Sts_LoLoDev	1 = PV deviation (loop error) is < Low-Low limit, $(Val_{PV} - Val_{SP}) < Cfg_LoLoDevLim$, for gate open. There is a predefined default discrete tag-based alarm for the status. Set standard configuration members of the discrete tag-based alarm. Access alarm elements using this format: <code>PPIDTag.@Alarms.Alm_LoLoDev.AlarmElement</code>	

Table 29 - Equivalent Output Parameters - PIDE Instruction and PPID Instruction (Continued)

PIDE Instruction			PPID Instruction		Comment
Parameter	Data Type	Description	PPID Parameter	Description	
CasRat	BOOL	Cascade/ratio mode indicator. Set to true when in the Cascade/Ratio mode.	Sts_Casc	1 = Loop is in Cascade/Ratio mode.	—
Auto	BOOL	Auto mode indicator. Set to true when in the Auto mode.	Sts_Auto	1 = Loop is in Auto mode.	—
Manual	BOOL	Manual mode indicator. Set to true when in the Manual mode.	Sts_Man	1 = Loop is in Manual mode.	—
Override	BOOL	Override mode indicator. Set to true when in the Override mode.	Sts_Ovrd	1 = Override is selected, supersedes Ext, Prog, Oper.	Override is different in the PPID instruction. For more information, see Differences in Override on page 259
Hand	BOOL	Hand mode indicator. Set to true when in the Hand mode.	Sts_Hand	1 = Hand is selected, supersedes OoS, Maint, Ovrd, Ext, Prog, Oper.	—
DeltaT	REAL	Elapsed time between updates. This is the elapsed time in seconds used by the control algorithm to calculate the process output.	Val_ExecTime	Actual PID algorithm execution period (second).	—
PVFaulted (Status1. 1)	BOOL	Process variable (PV) health bad.	Sts_PVBad	1 = PV input value, communications, quality or EU limit is bad.	Sts_PVBad status in the PPID instruction is not only set when Inp_PVBad = 1 (similar to the PIDE instruction and PVFault). There are also other conditions which are not in PIDE. For more information, see the PV bad status section in the PPID instruction online help.
CVFaulted (Status1. 2)	BOOL	Control variable (CV) health bad.	Sts_CVBad	1 = CV value quality is bad or invalid or CV comms fault.	—
HandFBFaulted (Status1. 3)	BOOL	HandFB value health bad.	Sts_HandFdbkBad	1 = Hand FB (Tieback) value quality is bad or invalid or communication fault.	Sts_HandFdbkBad in the PPID instruction is not only set when Inp_HandFdbkBad=1, but also if Inp_HandFdbk value is Inf, -Inf or NaN.
PVSpanInv (Status1. 4)	BOOL	Invalid span of PV. PVEUMax \leq PVEUMin.	Sts_ErrPVEU	1 = Error in the PPID instruction configuration: PV scaling limits invalid. Cfg_PVEUMin \geq Cfg_PVEUMax or Cfg_PVEUMin is +-Inf.	There is a difference between PIDE and PPID because PPID sets Sts_ErrPVEU also when Cfg_PVEUMin or Cfg_PVEUMax is Inf, -Inf or NaN.
SPLimitsInv (Status1. 8)	BOOL	Limits invalid: SPLLimit < PVEUMin, SPHLimit > PVEUMax, or SPHLimit < SPLLimit. If SPHLimit < SPLLimit, the instruction limits the value using SPLLimit	Sts_ErrSPLim	1 = Error in PPID configuration: SP clamping limits invalid. Cfg_SPLoLim < Cfg_PVEUMin or Cfg_SPHiLim > Cfg_PVEUMax or Cfg_SPLoLim > Cfg_SPHiLim.	There is a difference how the PPID handles invalid configuration when Cfg_SPHiLim < Cfg_SPLoLim. For more information, see the SP Handling section in the PPID instructions online help.
RatioLimitsInv (Status1. 11)	BOOL	RatioLLimit < 0 or RatioHLimit < RatioLLimit.	Sts_ErrRatioLim	1 = Error in the PPID instruction configuration: Ratio clamping limits invalid. Cfg_RatioLoLim > Cfg_RatioHiLim.	There is a difference in the condition when the status is set. PPID does not set ratio error when Cfg_RatioLoLim < 0.
CVPreviousInv (Status1. 15)	BOOL	CVPrevious < 0 or CVPrevious > 100, or CVPrevious < CVLLimit or CVPrevious > CVHLimit when in Auto or Cascade/Ratio mode. The instruction limits the value of CV _{n-1} .	Sts_CVPrevBad	1 = Inp_CVPrev value is invalid.	There is a difference between the instructions: <ul style="list-style-type: none"> • PIDE: Status CVPreviousInv is set regardless of the request CVSetPrevious value • PPID: Status Sts_CVPrevBad is set only if Inp_UseCVPrev = 1 There is also a difference that in the allowed range: <ul style="list-style-type: none"> • PIDE: Allowed range of CVPrevious changes based on mode • PPID: Allowed range is always between Cfg_CVEUMin and Cfg_CVEUMax

Table 29 - Equivalent Output Parameters - PIDE Instruction and PPID Instruction (Continued)

PIDE Instruction			PPID Instruction		Comment
Parameter	Data Type	Description	PPID Parameter	Description	
CVEUSpanInv (Status1. 16)	BOOL	Invalid CVEU span. The instruction uses a value of CVEUMax = CVEUMin.	Sts_ErrCVEU	1 = Error in the PPID instruction configuration: CV scaling limits invalid. Cfg_CVEUMin ≥ Cfg_CVEUMax or Cfg_CVEUMin is +-Inf.	There is a difference between PIDE and PPID because PPID does not allow Cfg_CVEUMin > Cfg_CVEUMax and sets Sts_ErrCVEU also when Cfg_CVEUMin or Cfg_CVEUMax is Inf, -Inf or NaN.
CVLimitsInv (Status1. 17)	BOOL	CVLLimit < 0, CVHLimit > 100, or CVHLimit < CVLLimit. If CVHLimit < CVLLimit, the instruction limits CV using CVLLimit.	Sts_ErrCVLim	1 = Error in the PPID instruction configuration: CV clamping limits invalid. Cfg_CVLoLim < Cfg_CVEUMin or Cfg_CVHiLim > Cfg_CVEUMax or Cfg_CVLoLim > Cfg_CVHiLim.	—
CVROCLimitInv (Status1. 18)	BOOL	CVROCLimit < 0. The instruction disables ROC limiting.	Sts_ErrCVRoCIncrLim	1 = Error in PPID configuration: Maximum allowed CV rate of change increasing value invalid, Cfg_CVRoCIncrLim < 0.	PPID has 2 different parameters for limiting increasing and decreasing rate of change and each of them has error status.
			Sts_ErrCVRoCDecrLim	1 = Error in PPID configuration: Maximum allowed CV rate of change decreasing value invalid, Cfg_CVRoCDecrLim < 0.	
FFInv (Status1. 19)	BOOL	FF < -100 or FF > 100. The instruction uses the limited value for FF.	Sts_FFBad	1 = Feedforward term Inp_FF value is invalid.	
FFPreviousInv (Status 1. 20)	BOOL	FFPrevious < - 100 or FFPrevious > 100. The instruction uses the limited value for FF _{n-1} .	Sts_FFPrevBad	1 = Feedforward term Inp_FFPrev value is invalid.	In the PIDE instruction status FFPreviousInv is set regardless of the FFSetPrevious value. In the PPID instruction status Sts_FFPrevBad is set only if Inp_UseFFPrev = 1.
PGainInv (Status 1. 22)	BOOL	PGain < 0. The instruction uses a value of PGain = 0.	Sts_ErrPGain	1 = Error in the PPID instruction configuration: PGain invalid, Cfg_PGain < 0.	—
IGainInv (Status1. 23)	BOOL	IGain < 0. The instruction uses a value of IGain = 0.	Sts_ErrIGain	1 = Error in the PPID instruction configuration: IGain invalid, Cfg_IGain < 0.	—
DGainInv (Status1. 24)	BOOL	DGain < 0. The instruction uses a value of DGain = 0.	Sts_ErrDGain	1 = Error in the PPID instruction configuration: DGain invalid, Cfg_DGain < 0.	—
DevHLLimitsInv (Status1. 28)	BOOL	Deviation high-low limits invalid. Low-low limit < 0, low limit < 0, high limit < 0, or high-high limit < 0. The instruction uses 0 for the invalid limit.	Sts_ErrHiHiDevLim	1 = Error in PPID configuration: High-High PV deviation threshold invalid, Cfg_HiHiDevLim < 0.	Each definition alarm limit in the PPID instruction has an error status.
			Sts_ErrHiDevLim	1 = Error in PPID configuration: High PV deviation threshold invalid, Cfg_HiDevLim < 0.0.	
			Sts_ErrLoDevLim	1 = Error in PPID configuration: Low PV deviation threshold invalid, Cfg_LoDevLim > 0.	
			Sts_LoLoDevLim	1 = Error in PPID configuration: Low-Low PV deviation threshold invalid, Cfg_LoLoDevLim > 0.0.	
DevDeadbandInv (Status1. 29)	BOOL	Deviation deadband < 0. The instruction uses a value of DevDeadband = 0.	Sts_ErrHiHiDevDB	1 = Error in PPID configuration: High-High PV deviation deadband invalid, Cfg_HiHiDevDB < 0 or Cfg_HiHiDevDB > Cfg_HiHiDevLim.	Each deviation alarm in the PPID instruction has its own deadband configuration parameter and there are also individual error statuses.
			Sts_ErrHiDevDB	1 = Error in PPID configuration: High PV deviation deadband invalid, Cfg_HiDevDB < 0 or Cfg_HiDevDB > Cfg_HiDevLim.	
			Sts_ErrLoDevDB	1 = Error in PPID configuration: Low PV deviation deadband invalid, Cfg_LoDevDB < 0, or > -Cfg_LoDevLim.	
			Sts_ErrLoLoDevDB	1 = Error in PPID configuration: Low-Low PV deviation deadband invalid, Cfg_LoLoDevDB < 0, or > -Cfg_LoLoDevLim.	

Alternative Output Parameters

The following table describes output parameters in the PIDE instruction for which there are alternative output parameters in the PPID instruction that you can use.

Table 30 - Alternative Output Parameters - PIDE Instruction and PPID Instruction

PIDE Instruction			PPID Instruction		Comment
Parameter	Data Type	Description	PPID Parameter	Description	
CVHAlarm	BOOL	CV high alarm indicator. Set to true when the calculated value of CV > 100 or CVHLimit.	Sts_CVRamping	1 = CV is ramping toward Val_CVSet 0 = Ramp complete.	The PPID instruction status Sts_CVHiClamped indicates that the calculated CV value is limited by Cfg_CVHiLim. It can be used as alternative if Cfg_SkipCVManLim=0, otherwise the indication is turned off when in Manual, Hand, CV initializing or CV shed. The CVHAlarm status is always indicated in the PIDE instruction. Additional logic is required for exact replacement. For more information, see Differences In Alarming on page 248 .
CVLAlarm	BOOL	CV low alarm indicator. Set to true when the calculated value of CV < 0 or CVLLimit.	Sts_CVLoClamped	1 = CV is being clamped at low limit.	The PPID instruction status Sts_CVLoClamped indicates that calculated CV value is limited by Cfg_CVLoLim. It can be used as alternative if Cfg_SkipCVManLim=0, otherwise the indication is turned off when in Manual, Hand, CV initializing or CV shed. The CVLAlarm status is always indicated in PIDE. Additional logic is required for exact replacement. For more information, see Differences In Alarming on page 248 .
ZCDeadbandOn	BOOL	Zero crossing deadband indicator. When true the value of CV does not change. If ZCOff is true, then ZCDeadbandOn is set to true when E is within the ZCDeadband range. If ZCOff is false, then ZCDeadbandOn is set to true when E crosses zero and remains within the ZCDeadband range. ZCDeadbandOn is cleared to false when E exceeds the deadband range or when ZCDeadband = 0.	Sts_DevDBAct	1 = PV deviation deadband active.	The PIDE instruction uses the Zero Crossing deadband. The PPID instruction uses the PV deviation deadband instead. For more information, see Zero Crossing Deadband and Process Variable Deviation Deadband on page 254 .
ProgOper	BOOL	Program/operator control indicator. Set to true when in Program control. Cleared to false when in Operator control.	Sts_Prog	1 = Program is selected.	PPID has separate statuses for Program and Operator command source.
			Sts_Oper	1 = Operator is selected.	
InstructFault (Status1. 0)	BOOL	The instruction detected one of the following execution errors. This is not a minor or major controller error. Check the remaining status bits to determine what occurred.	Sts_NotRdy	1 = PPID is not ready, see detail bits for reason.	Sts_NotRdy can be used as a general status indicating there is an issue with PPID instruction.
SPProgInv (Status1. 5)	BOOL	SPProg < SPLLimit or SPProg > SPHLimit. The instruction uses the limited value for SP.	Sts_SPClamped	1 = Selected SP is being clamped, for faceplate animation.	Status Sts_SPClamped is common for all command sources and indicates that the setpoint coming from the selected source is out of limits and is clamped.
SPOperInv (Status1. 6)	BOOL	SPOper < SPLLimit or SPOper > SPHLimit. The instruction uses the limited value for SP.			
SPCascadeInv (Status1. 7)	BOOL	SPCascade < SPLLimit or SPCascade > SPHLimit. The instruction uses the limited value for SP.			

Table 30 - Alternative Output Parameters - PIDE Instruction and PPID Instruction (Continued)

PIDE Instruction			PPID Instruction		Comment
Parameter	Data Type	Description	PPID Parameter	Description	
RatioProgInv (Status1. 9)	BOOL	RatioProg < RatioLLimit or RatioProg > RatioHLimit. The instruction limits the value for Ratio.	Sts_RatioClamped	1 = Selected Ratio is being clamped, used in faceplate animation.	Status Sts_RatioClamped is common for all command sources and indicates that the ratio coming from the selected source is out of limits and is clamped.
RatioOperInv (Status1. 10)	BOOL	RatioOper < RatioLLimit or RatioOper > RatioHLimit. The instruction limits the value for Ratio.			
CVProgInv (Status1. 12)	BOOL	CVProg < 0 or CVProg > 100, or CVProg < CVLLimit or CVProg > CVHLimit when CVManLimiting is true. The instruction limits the value for CV.	Sts_CVClamped	1 = Selected CV is being clamped, used in faceplate animation.	Status Sts_CVClamped is common for all command sources and indicates that the CV coming from the selected source is out of limits and is clamped. The CV clamped status is not set in the PPID instruction when CV is outside Cfg_CVEUMin and Cfg_CVEUMax limits (these correspond to PIDE 0% and 100%).
CVOperInv (Status1. 13)	BOOL	CVOper < 0 or CVOper > 100, or CVOper < CVLLimit or CVOper > CVHLimit when CVManLimiting is true. The instruction limits the value for CV.			
CVOverrideInv (Status 1. 14)	BOOL	CVOverride < 0 or CVOverride > 100. The instruction limits the value for CV.			
ZCDeadbandInv (Status1. 25)	BOOL	ZCDeadband < 0. The instruction disables zero crossing deadband.	Sts_ErrDevDB	1 = Error in the PPID instruction configuration: PV deviation deadband invalid. Cfg_DevDBEnter > Cfg_DevDB, or Cfg_DevDB < 0, or Cfg_DevDBEnter < 0.	The PIDE instruction uses the Zero Crossing deadband. The PPID instruction uses the PV deviation deadband instead. For more information, see Zero Crossing Deadband and Process Variable Deviation Deadband on page 254 .

No Equivalent Output Parameters

The following table describes output parameters in the PIDE instruction that have no equivalent in the PPID instruction.

Table 31 - No Equivalent Output Parameters - PIDE Instruction and PPID Instruction

PIDE Instruction			Comment
Parameter	Data Type	Description	
RatioHAlarm	BOOL	Ratio high alarm indicator. Set to true when Ratio > RatioHLimit.	RatioHAlarm and RatioLAlarm statuses can be replaced using additional logic. For more information, see Differences In Alarming on page 248 .
RatioLAlarm	BOOL	Ratio low alarm indicator. Set to true when Ratio < RatioLLimit.	
PVHHighAlarm	BOOL	PV high-high alarm indicator. Set to true when PV ≥ PVHHLimit. Cleared to false when PV < (PVHHLimit - PVDeadband)	Replaced using tag-based alarms if alarm is needed in HMI. Replaced using external logic if alarm indicator is needed in logic. For more information, see Differences In Alarming on page 248
PVHAlarm	BOOL	PV high alarm indicator. Set to true when PV ≥ PVHLimit. Cleared to false when PV < (PVHLimit - PVDeadband)	
PVLowAlarm	BOOL	PV low alarm indicator. Set to true when PV ≤ PVLLimit. Cleared to false when PV > (PVLLimit + PVDeadband)	
PVLLAlarm	BOOL	PV low-low alarm indicator. Set to true when PV ≤ PVLLLimit. Cleared to false when PV > (PVLLLimit + PVDeadband)	
PVROCPosAlarm	BOOL	PV positive rate-of-change alarm indicator. Set to true when calculated PV rate-of-change ≥ PVROCPosLimit.	
PVROCNegAlarm	BOOL	PV negative rate-of-change alarm indicator. Set to true when calculated PV rate-of-change ≤ (PVROCNegLimit x -1).	
AtuneReady	BOOL	Set to true when the specified AtuneData has been acquired by the PIDE instruction.	Autotuning statuses have no equivalent in the PPID instruction.
AtuneOn	BOOL	Set to true when auto tuning has been initiated.	
AtuneDone	BOOL	Set true when auto tuning has completed.	
AtuneAborted	BOOL	Set to true when auto tuning has been aborted by the user or due to errors that occurred during the auto tuning operation.	
AtuneBusy	BOOL	Set to true when the specified AtuneData could not be acquired because it is acquired by another PIDE instruction.	
Status1	BOOL	Status of the function block.	There is no status DINT in the PPID instruction where the individual bits are aliased as error statuses.
HandFBInv (Status1. 21)	BOOL	HandFB < 0 or HandFB > 100. The instruction uses the limited value for CV.	There is no status in the PPID instruction for Hand feedback out of limits.
PVDeadbandInv (Status1. 26)	BOOL	PVDeadband < 0. The instruction limits PVDeadband to zero.	These error statuses are related to PIDE alarms and do not have an equivalent in the PPID instruction.
PVROCLimitsInv (Status 1. 27)	BOOL	PVROCPosLimit < 0, PVROCNegLimit < 0, or PVROCPeriod < 0.	
Status2	DINT	Timing status of the function block.	Statuses related to timing modes. There is no equivalent.
TimingModeInv (Status2.27)	BOOL	Invalid TimingMode value. For more information about timing modes, see Function Block Attributes.	
RTSMissed (Status2. 28)	BOOL	Only used in real time sampling mode. Set to true when $ABS \Delta T - RTSTime > 1 (.001 \text{ second})$.	
RTSTimeInv (Status2. 29)	BOOL	Invalid RTSTime value.	
RTSTimeStampInv (Status2. 30)	BOOL	Invalid RTSTimeStamp value.	
DeltaTInv (Status2. 31)	BOOL	Invalid DeltaT value.	

Differences In Alarming

Alarming is different with the PPID instruction compared to the PIDE instruction.

- The PIDE instruction offers the following alarms:
 - CV
 - SP
 - Ratio
 - PV
 - Deviation
- The PPID instruction only offers tag-based alarms. You use the Logix Alarm Manager for:
 - High high deviation
 - High deviation
 - Low deviation
 - Low Low deviation
 - Interlock trip
 - Instruction failure

The PPID configurations that are proposed as alternatives for PIDE alarms are as follows.

Table 32 - Differences in Alarms



Alarm	PIDE Alarm Indicator	PPID Alarm	PPID Alternative/Comment
CV high	CVHAlarm	—	<p>Sts_CVHiClamped indicates that calculated CV value is limited by Cfg_CVHiLim. This status is always cleared in Manual, Hand, CV initializing or CV shed if Cfg_SkipCVManLim is set. If the alarm indicator is required under these conditions, additional logic is needed.</p> 
CV low	CVLAlarm	—	<p>Sts_CVLoClamped indicates that calculated CV value is limited by Cfg_CVLoLim. This status is always cleared in Manual, Hand, CV initializing or CV shed if Cfg_SkipCVManLim is set. If the alarm indicator is required under these conditions, additional logic is needed.</p> 

Table 32 - Differences in Alarms (Continued)



Alarm	PIDE Alarm Indicator	PPID Alarm	PPID Alternative/Comment
CV rate-of-change	CVROCAAlarm	—	<p>Sts_CVRamping can be used as an equivalent.</p> <p>There is a difference between the instructions when actual CV rate of change is equal to the rate of change limit:</p> <ul style="list-style-type: none"> • PIDE: sets CVROCAAlarm status (although the parameter description claims that it is set when CVROCLimit is exceeded) • PPID: clears Sts_CVRamping status
SP high	SPHAlarm	—	<p>Sts_SPHiClamped can be used as an equivalent.</p> <p>The only difference is behavior when there is an exceptional condition.</p> <ul style="list-style-type: none"> • PIDE: SPHAlarm is not evaluated when the SP limits configuration is invalid (SPLimitsInv is set) • PPID: Sts_SPHiClamped is not evaluated if SP is not held by shed (Sts_SPHeld=0), and SP is not set to interlock SP by shed (Sts_IntlkSP=0), and SP clamping limits are valid (Sts_ErrSPLim=0)
SP low	SPLAlarm	—	<p>Sts_SPLoClamped can be used as an equivalent.</p> <p>The only difference is behavior when there is an exceptional condition.</p> <ul style="list-style-type: none"> • PIDE: SPLAlarm is not evaluated when the SP limits configuration is invalid (SPLimitsInv is set) • PPID: Sts_SPLoClamped is not evaluated if SP is not held by shed (Sts_SPHeld=0), and SP is not set to interlock SP by shed (Sts_IntlkSP=0), and SP clamping limits are valid (Sts_ErrSPLim=0).
Ratio high	RatioHAlarm	—	<p>Sts_RatioClamped indicates that the ratio coming from the selected source is out of limits and is clamped. The information whether it is clamped at high limit is missing in the instruction, so additional logic is needed to get this information in the alarm indicator.</p> 
Ratio low	RatioLAlarm	—	<p>Sts_RatioClamped indicates that the ratio coming from the selected source is out of limits and is clamped. The information whether it is clamped at high limit is missing in the instruction, so additional logic is needed to get this information in the alarm indicator.</p> 

Table 32 - Differences in Alarms (Continued)

Alarm	PIDE Alarm Indicator	PPID Alarm	PPID Alternative/Comment
PV high-high	PVHHAAlarm	—	<p>The PV high-high alarm indicator is not available in the PPID instruction and additional logic is required to implement an alternative.</p> <p>The PVHHAAlarm indicator is set to true when $Inp_PV \geq PVHHLimit$ and cleared to false when $PV < (PVHHLimit - PVDeadband)$ or if the quality of PV input is bad.</p> 
PV high	PVHAAlarm	—	<p>The PV high alarm indicator is not available in the PPID instruction and additional logic is required to implement an alternative.</p> <p>The PVHAAlarm indicator is set to true when $Inp_PV \geq PVHLimit$ and cleared to false when $PV < (PVHLimit - PVDeadband)$ or if the quality of PV input is bad.</p> 
PV low	PVLAAlarm	—	<p>The PV low alarm indicator is not available in the PPID instruction and additional logic is required to implement an alternative.</p> <p>The PVLAAlarm indicator is set to true when $PV \leq PVLLimit$ and cleared to false when $PV > (PVLLimit + PVDeadband)$ or if the quality of PV input is bad.</p> 
PV low-low	PVLLAlarm	—	<p>The PV low-low alarm indicator is not available in the PPID instruction and additional logic is required to implement an alternative.</p> <p>The PVLLAlarm indicator is set to true when $PV \leq PVLLLimit$ and cleared to false when $PV > (PVLLLimit + PVDeadband)$ or if quality of PV input is bad.</p> 

Table 32 - Differences in Alarms (Continued)

Alarm	PIDE Alarm Indicator	PPID Alarm	PPID Alternative/Comment
PV positive rate-of-change	PVROCPoSAlarm	—	<p>The PV positive rate-of-change alarm indicator and the PV negative rate-of-change alarm indicator are not available in the PPID instruction and additional logic is required to implement an alternative. Configuration parameters PVROCPoSLimit, PVROCNegLimit and PVROCPeiod are used in the same way as in the PIDE instruction.</p> <ul style="list-style-type: none"> PVROCPoSAlarm is set to true when calculated PV rate-of-change \geq PVROCPoSLimit. PVROCNegAlarm is set to true when calculated PV rate-of-change \leq -PVROCNegLimit.
PV negative rate-of-change	PVROCNegAlarm	—	
Deviation high-high	DevHHAAlarm	Alm_HiHiDev	<p>The PPID instruction has an Alm_HiHiDev tag-based alarm that is defined for the Sts_HiHiDev alarm indicator. The threshold, deadband, gating, and timing are set in configuration. Once triggered, the Sts_HiHiDev alarm stays On for at least 2.5s, which is the time required for correct function of tag-based alarms and alarm set.</p> <p>The Sts_HiHiDevCmp output parameter can be used as alternative if deviation high-high alarm indicator is needed in logic without gating functionality and the minimum On time</p>
Deviation high	DevHAAlarm	Alm_HiDev	<p>The PPID instruction has an Alm_HiDev tag-based alarm that is defined for the Sts_HiDev alarm indicator. The threshold, deadband, gating, and timing are set in configuration. Once triggered, the Sts_HiDev alarm stays On for at least 2.5s, which is the time required for correct function of tag-based alarms and alarm set.</p> <p>The Sts_HiDevCmp output parameter can be used as alternative if deviation high-high alarm indicator is needed in logic without gating functionality and the minimum On time.</p>
Deviation low	DevLAlarm	Alm_LoDev	<p>The PPID instruction has an Alm_LoDev tag-based alarm that is defined for the Sts_LoDev alarm indicator. The threshold, deadband, gating, and timing are set in configuration. Once triggered, the Sts_LoDev alarm stays On for at least 2.5s, which is the time required for correct function of tag-based alarms and alarm set.</p> <p>Sts_LoDevCmp output parameter can be used as alternative if deviation high-high alarm indicator is needed in logic without gating functionality and the minimum On time.</p>

Table 32 - Differences in Alarms (Continued)

Alarm	PIDE Alarm Indicator	PPID Alarm	PPID Alternative/Comment
Deviation low-low	DevLLAlarm	Alm_LoLoDev	The PPID instruction has an Alm_LoLoDev tag-based alarm that is defined for the Sts_LoLoDev alarm indicator. The threshold, deadband, gating, and timing are set in configuration. Once triggered, the Sts_LoLoDev alarm stays On for at least 2.5s, which is the time required for correct function of tag-based alarms and alarm set. The Sts_LoLoDevCmp output parameter can be used as alternative if deviation high-high alarm indicator is needed in logic without gating functionality and the minimum On time.
Instruction failure	—	Alm_Fail	The PPID instruction has an Alm_Fail tag-based alarm that is defined for the Sts_Fail alarm indicator. It is raised when the PPID instruction reports an Instruction Fault. The fault is reported under any of these conditions: <ul style="list-style-type: none"> • Setpoint (SP) bad quality, Sts_SPBad = 1 • Process variable (PV) bad quality, Sts_PVBad = 1 • Control variable (CV) bad quality, Sts_CVBad = 1 • Hand feedback (HandFdbk) bad quality, Sts_HandFdbkBad = 1
Interlock trip	—	Alm_IntlkTrip	The PPID instruction has an Interlock Trip tag-based alarm that is defined for Sts_IntlkTrip. It is raised when non-bypassable interlocks are not OK or bypassable interlocks are not OK when not bypassed.

You configure the Deviation alarms parameters on the Parameters tab of the instruction properties dialog box.

Table 33 - Alarm Parameters

PIDE - Deviation Alarms Configuration	PPID - Deviation Alarms Configuration																																				
	<table border="1"> <thead> <tr> <th>Use</th> <th>Alarm</th> <th>Gate delay</th> <th>Limit</th> <th>Deadband</th> <th>State</th> </tr> </thead> <tbody> <tr> <td><input type="checkbox"/></td> <td>High high devia...</td> <td>0.000</td> <td>1.50000000e+038</td> <td>0.0</td> <td>...</td> </tr> <tr> <td><input type="checkbox"/></td> <td>High deviation</td> <td>0.000</td> <td>1.50000000e+038</td> <td>0.0</td> <td>...</td> </tr> <tr> <td><input type="checkbox"/></td> <td>Low deviation</td> <td>0.000</td> <td>-1.50000000e+038</td> <td>0.0</td> <td>...</td> </tr> <tr> <td><input type="checkbox"/></td> <td>Low low deviation</td> <td>0.000</td> <td>-1.50000000e+038</td> <td>0.0</td> <td>...</td> </tr> <tr> <td><input type="checkbox"/></td> <td>Interlock trip</td> <td></td> <td></td> <td></td> <td>...</td> </tr> </tbody> </table>	Use	Alarm	Gate delay	Limit	Deadband	State	<input type="checkbox"/>	High high devia...	0.000	1.50000000e+038	0.0	...	<input type="checkbox"/>	High deviation	0.000	1.50000000e+038	0.0	...	<input type="checkbox"/>	Low deviation	0.000	-1.50000000e+038	0.0	...	<input type="checkbox"/>	Low low deviation	0.000	-1.50000000e+038	0.0	...	<input type="checkbox"/>	Interlock trip				...
Use	Alarm	Gate delay	Limit	Deadband	State																																
<input type="checkbox"/>	High high devia...	0.000	1.50000000e+038	0.0	...																																
<input type="checkbox"/>	High deviation	0.000	1.50000000e+038	0.0	...																																
<input type="checkbox"/>	Low deviation	0.000	-1.50000000e+038	0.0	...																																
<input type="checkbox"/>	Low low deviation	0.000	-1.50000000e+038	0.0	...																																
<input type="checkbox"/>	Interlock trip				...																																

Timing Mode Parameters That Are Not Available In PPID Instruction

The PPID instruction operates in Periodic mode. Oversample and Real Time Sampling are not included. The following graphic shows where to configure the Periodic timing mode parameters in the PPID instruction.

Figure 34 - PPID Instruction Timing Mode Parameters in Logix Designer

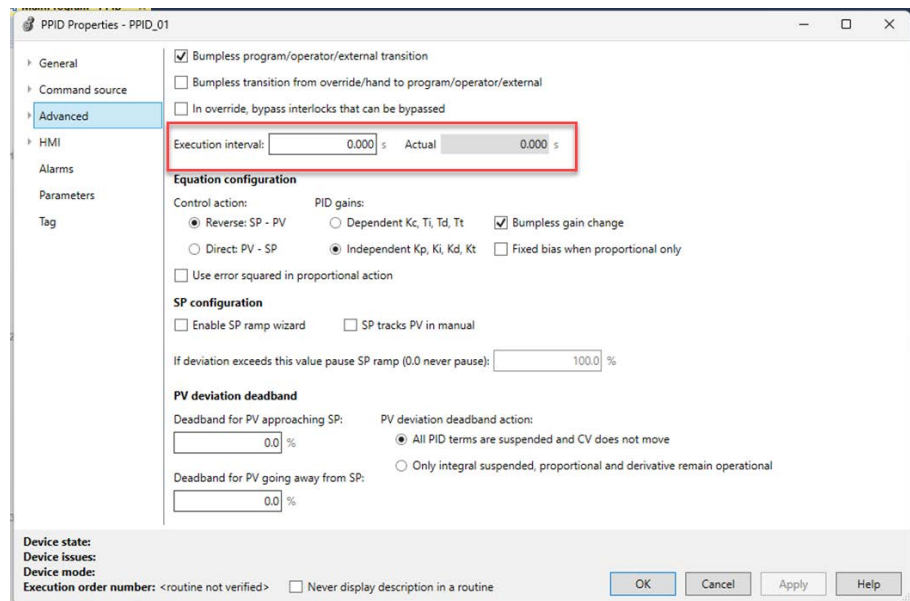

Zero Crossing Deadband and Process Variable Deviation Deadband

An adjustable deadband lets you select an error range above and below the SP where output does not change as long as the error remains within this range. The deadband lets you control how closely the PV matches the SP without changing the output.

The PPID instruction uses the PV deviation deadband instead that is more general than the Zero Crossing deadband used in the PIDE instruction. To get the same behavior, use the following settings.

Always set `PPID.Cfg_UseIntegDevDB = 0`, and `PPID.Cfg_DevDB = PIDE.ZCDeadband`. Set `PPID.Cfg_DevDBEnter` as follows:

- If `PIDE.ZCOff = 0` set `PPID.Cfg_DevDBEnter = 0`.
- If `PIDE.ZCOff = 1` set `PPID.Cfg_DevDBEnter = PIDE.ZCDeadband`.
- Output indicator `PPID.Sts_DevDBAct` is equivalent to `PIDE.ZCDeadbandOn`.

The PIDE PV deviation deadband parameters are defined as follows.

Parameter		Description
Name	Type	
ZCDeadband	Input	Zero crossing deadband range scaled in PV units. Defines the zero crossing deadband range. Enter 0 to disable the zero crossing deadband checking. If <code>ZCDeadband < 0</code> , the instruction sets the appropriate bit in Status and disables zero crossing deadband checking. Valid = 0.0 to maximum positive float Default = 0.0
ZCOff	Input	Zero crossing disable request. Set to true to disable zero crossing for the deadband calculation. Default is false.
ZCDeadbandOn	Output	Zero crossing deadband indicator. When true the value of CV does not change. If <code>ZCOff</code> is true, then <code>ZCDeadbandOn</code> is set to true when $ E $ is within the <code>ZCDeadband</code> range. If <code>ZCOff</code> is false, then <code>ZCDeadbandOn</code> is set to true when $ E $ crosses zero and remains within the <code>ZCDeadband</code> range. <code>ZCDeadbandOn</code> is cleared to false when $ E $ exceeds the deadband range or when <code>ZCDeadband = 0</code> .
ZCDeadbandInv	Output	<code>ZCDeadband < 0</code> . The instruction disables zero crossing deadband.

The PPID PV deviation deadband parameters are defined as follows.

Parameter		Description
Name	Type	
<code>Cfg_UseIntegDevDB</code>	Input	1 = Only integral term is suspended when PV deviation deadband status is active, proportional, and derivative terms remain operational, 0 = All PID terms are suspended and CV does not move when PV deviation deadband status is active. Default is false.
<code>Cfg_DevDBEnter</code>	Input	PV deviation deadband for PV approaching SP (PVEU). Valid = 0.0 to <code>Cfg_DevDB</code> .
<code>Cfg_DevDB</code>	Input	PV deviation deadband for PV going away from SP (PVEU). Valid = 0.0 to maximum positive float.
<code>Sts_DevDBAct</code>	Output	1 = PV deviation deadband active.
<code>Sts_ErrDevDB</code>	Output	1 = Error in the PPID instruction configuration: PV deviation deadband invalid. <code>Cfg_DevDBEnter > Cfg_DevDB</code> , or <code>Cfg_DevDB < 0</code> , or <code>Cfg_DevDBEnter < 0</code> .

For the PIDE instruction, you configure the Zero-Crossing deadband parameters on the Parameters tab of the instruction properties dialog box.

For the PPID instruction, you configure the Deviation deadband parameters on the Advanced tab.

Table 34 - Deadband Parameters

PIDE Instruction - Zero-Crossing Deadband

Vis	Name	Value	Type	Description
<input type="checkbox"/>	PVTracking	0	BOOL	SP track PV request. Set TRUE to enable ...
<input checked="" type="checkbox"/>	ZCDeadband	0.0	REAL	Zero crossing deadband range, scaled in P...
<input type="checkbox"/>	ZCOff	0	BOOL	Zero crossing control action request. Whe...
<input checked="" type="checkbox"/>	PVHHLimit	3.40282347e+038	REAL	PV high-high alarm limit value, scaled in PV...
<input type="checkbox"/>	PVHLimit	3.40282347e+038	REAL	PV high alarm limit value, scaled in PV units...
<input type="checkbox"/>	PVLLimit	-3.40282347e+038	REAL	PV low limit value, scaled in PV units...
<input type="checkbox"/>	PVLLLimit	-3.40282347e+038	REAL	PV low-low alarm limit value, scaled in P...
<input type="checkbox"/>	PVDeadband	0.0	REAL	PV deadband alarm limit value, scaled in P...
<input type="checkbox"/>	PVROCPosLimit	0.0	REAL	PV positive rate of change alarm limit. Th...
<input type="checkbox"/>	PVROCNegLimit	0.0	REAL	PV negative rate of change alarm limit. Th...
<input type="checkbox"/>	PVROCPeriod	0.0	REAL	PV rate of change sample period. The time...
<input type="checkbox"/>	DevHHLimit	3.40282347e+038	REAL	Deviation high-high alarm limit value, scale...
<input type="checkbox"/>	DevHLimit	3.40282347e+038	REAL	Deviation high alarm limit value, scaled in P...
<input type="checkbox"/>	DevLLimit	3.40282347e+038	REAL	Deviation low alarm limit value, scaled in P...
<input type="checkbox"/>	DevLLLimit	3.40282347e+038	REAL	Deviation low-low alarm limit value, scaled i...

PPID - PV Deviation Deadband

PPID Properties - PPID_01

Advanced

Execution interval: 0.000 Actual: 0.000

Equation configuration

Control action: Reverse: SP - PV Dependent Kc, Ti, Td, Tt Bumpless gain change

Alarms: Direct: PV - SP Independent Kp, Ki, Kd, Kt Fixed bias when proportional only

SP configuration

Enable SP ramp wizard SP tracks PV in manual

If deviation exceeds this value pause SP ramp (0.0 never pause): 100.0 %

PV deviation deadband

Deadband for PV approaching SP: 0.0 %

PV deviation deadband action: All PID terms are suspended and CV does not move

Deadband for PV going away from SP: 0.0 %

Only integral suspended, proportional and derivative remain operational

Control Variable Rate of Change Limiting

The PIDE instruction lets you configure the CV rate of change limit in percent per second. The PPID instruction lets you configure the CV rate of change in an increasing limit and decreasing limit in CVEU per second.

For conversion from percent per second to CVEU per second use the following formula:

$$\text{ROC (EU)} = \text{ROC (\%)} * (\text{CVEUMax} - \text{CVEUMin}) / 100$$

The PIDE Control Variable Rate of Change Limiting parameters are defined as follows.

Parameter		Description
Name	Type	
CVROCLimit	Input	CV rate of change limit, in percent per second. Rate of change limiting is only used when in Auto or Cascade/Ratio modes or Manual mode if CVManLimiting is true. Enter 0 to disable CV ROC limiting. If CVROCLimit < 0, the instruction sets the appropriate bit in Status and disables CV ROC limiting. Valid = 0.0 to maximum positive float Default = 0.0
CVROCLimitInv	Output	CVROCLimit < 0. The instruction disables ROC limiting.

The PPID instruction Control Variable Rate of Change Limiting parameters are defined as follows.

Parameter		Description
Name	Type	
Cfg_CVRoCDecrLim	Input	Maximum allowed CV rate of change decreasing value (CVEU/second). The CV rate of change is unlimited when decreasing if this value is 0.0. Valid value = Any positive floating point value up to the maximum value (default = 0.0)
Cfg_CVRoCIncrLim	Input	Maximum allowed CV rate of change increasing value (CVEU/second). The CV rate of change is unlimited when decreasing if this value is 0.0. Valid value = 0.0 to maximum positive float Default = 0.0
Sts_ErrCVRoCIncrLim	Output	1 = Error in the PPID instruction configuration: Maximum allowed CV rate of change increasing value invalid, Cfg_CVRoCIncrLim < 0.
Sts_ErrCVRoCDecrLim	Output	1 = Error in the PPID instruction configuration: Maximum allowed CV rate of change decreasing value invalid, Cfg_CVRoCDecrLim < 0.

You configure the Control Variable Rate of Change Limiting parameters on the Parameters tab of the PPID instruction properties dialog box.

Table 35 - CV Rate of Change Parameters

PIDE Instruction - CV Rate of Change

Vis	Name	Value	Type	Description
<input type="checkbox"/>	CVLimit	0.0	REAL	CV low limit value. This is used to set the C...
<input checked="" type="checkbox"/>	CVROCLimit	0.0	REAL	CV rate of change limit, in percent per seco...
<input type="checkbox"/>	FF	0.0	REAL	Feed forward value. The value of feed for...
<input type="checkbox"/>	FFPrevious	0.0	REAL	FFn-1 initialization value. If FFSetPrevious ...
<input type="checkbox"/>	FFSetPrevious	0	BOOL	FFn-1 initialization request. If TRUE, set FF...
<input type="checkbox"/>	HandFB	0.0	REAL	CV HandFeedback value. CV set to this v...
<input type="checkbox"/>	HandFBFault	0	BOOL	HandFB value bad health indicator. If the ...
<input type="checkbox"/>	WindupHIn	0	BOOL	Windup high request. When TRUE, CV will ...
<input type="checkbox"/>	WindupLin	0	BOOL	Windup low request. When TRUE, CV will ...
<input type="checkbox"/>	ControlAction	0	BOOL	Control action request. Set TRUE to calcul...
<input type="checkbox"/>	DependIndepend	0	BOOL	Dependent/Independent control request. ...
<input type="checkbox"/>	PGain	0.0	REAL	Proportional gain, no units (scalar).
<input type="checkbox"/>	IGain	0.0	REAL	Integral gain.
<input type="checkbox"/>	DGain	0.0	REAL	Derivative gain.
<input type="checkbox"/>	PVProportional	0	BOOL	Proportional PV control request.

PPID - CV Rate of Change

Vis	Name	Value	Type	Description
<input type="checkbox"/>	Cfg_CVHLim	100.0	REAL	Maximum allowed CV value (CVEU). Valid any float greater than or equal to Cfg...
<input checked="" type="checkbox"/>	Cfg_CVROCLim	0.0	REAL	Maximum allowed CV rate of change increasing value (CVEU)/second. The CV ...
<input type="checkbox"/>	Cfg_CVROCLim	0.0	REAL	Maximum allowed CV rate of change decreasing value (CVEU)/second. The CV ...
<input type="checkbox"/>	Cfg_MaxInactiveCV	0.0	REAL	When Val_CVOut is greater than this value, set Sts_Active for HMI (CVEU). Valid...
<input type="checkbox"/>	Cfg_SPInterk	0.0	REAL	SP value to use with interlock / bad value SP action (PVEU). Valid any float bet...
<input type="checkbox"/>	Cfg_CVInterk	0.0	REAL	CV value to use with interlock / bad value CV action (CVEU). Valid any float bet...
<input type="checkbox"/>	Cfg_SPPwrUp	0.0	REAL	Loop SP on Powerup (PVEU) used when Cfg_PwrUpLM is not 0. The value is cle...
<input type="checkbox"/>	Cfg_CVPerUp	0.0	REAL	Loop CV on Powerup (CVEU) used when Cfg_PwrUpLM is not 0. The value is cle...
<input type="checkbox"/>	Cfg_CVPerUpSet	0	SINT	Selection of Powerup (first run) CV in Auto or Cascade. 0 = Ignore Inp_InnerAva...
<input type="checkbox"/>	Cfg_HHDevLim	1.50000	REAL	High-High PV deviation status threshold (PVEU). Valid = 0.0 to maximum positi...
<input type="checkbox"/>	Cfg_HHDevDB	0.0	REAL	High-High PV deviation status deadband (PVEU). Valid = 0.0 to Cfg_HHDevLim.
<input type="checkbox"/>	Cfg_HHDevGateDly	10.0	REAL	High-High PV deviation status gate delay (second). Valid = 0.0 to 2147483.0 sec...
<input type="checkbox"/>	Cfg_HDevLim	1.50000	REAL	High PV deviation status threshold (PVEU). Valid = 0.0 to maximum positive floa...
<input type="checkbox"/>	Cfg_HDevDB	0.0	REAL	High PV deviation status deadband (PVEU). Valid = 0.0 to Cfg_HDevLim.
<input type="checkbox"/>	Cfg_HDevGateDly	0.0	REAL	High PV deviation status gate delay (second). Valid = 0.0 to 2147483.0 second...
<input type="checkbox"/>	Cfg_LoDevLim	-1.50000	REAL	Low PV deviation status threshold (PVEU). Valid = -maximum positive float to 0.0...
<input type="checkbox"/>	Cfg_LoDevDB	0.0	REAL	Low PV deviation status deadband (PVEU). Valid = 0.0 to abs(Cfg_LoDevLim).

Scaling limits

PV limits: Max: 100.0%, Min: 0.0%

CV limits: Max: 100.0%, Min: 0.0%

When the scaled CV out is greater than this value, the device is "active": 0.0%

Clamping limits

SP limits: High: 100.0%, Low: 0.0%

CV limits: High: 100.0%, Low: 0.0%

Ratio limits: High: 1.0, Low: 0.0

Rate of change limits

SP limits: Increasing: 0.0 %/s, Decreasing: 0.0 %/s

CV limits: Increasing: 0.0 %/s, Decreasing: 0.0 %/s

Skip SP rate of change limiting in interlock, maintenance and override

Skip CV clamping in manual or CV shed

Skip CV rate of change limiting in manual or CV shed

Control Variable Manual Limiting

CV manual limiting in the PIDE instruction is functionally opposite of CV manual limiting in the PPID instruction.

The PIDE Control Variable Manual Limiting parameter is defined as follows.

Parameter	Description
CVManLimiting	Limit CV in manual mode request. If Manual mode and CVManLimiting are true, CV is limited by the CVHLimit and CVLLimit values. Default is false.

The PPID Control Variable Manual Limiting parameter is defined as follows.

Parameter	Description
Cfg_SkipCVManLim	1 = Skip CV clamping in Manual loop mode and for CV from shed 0 = Always apply CV clamping.

You configure the Control Variable Manual Limiting parameters on the Parameters tab of the PPID instruction properties dialog box.

Table 36 - CV Limiting Parameters

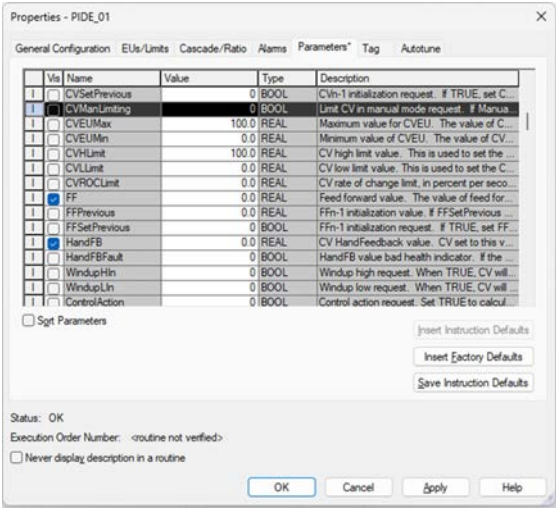
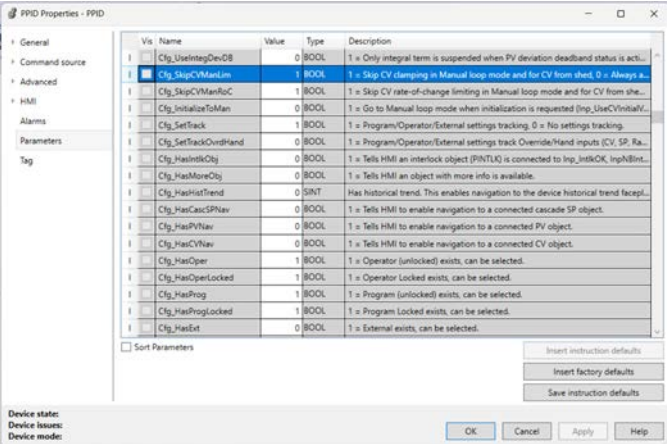
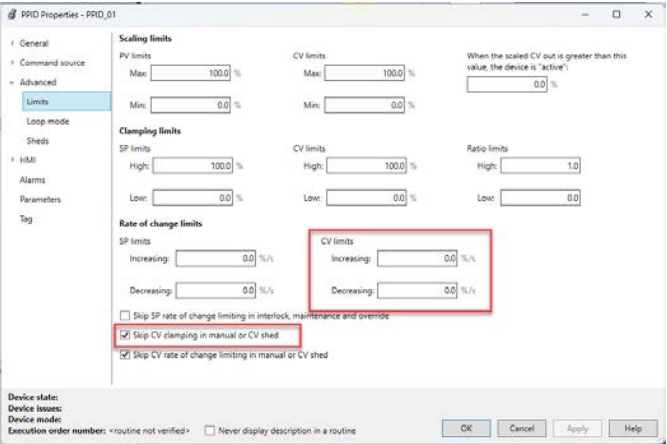
PIDE Instruction - CV Limiting in Manual Mode	PPID - CV Limiting in Manual Mode
 <p>The screenshot shows the 'Properties - PIDE_01' dialog box with the 'Parameters' tab selected. A table lists various parameters. The 'CVManLimiting' parameter is highlighted in blue. Its value is 0, type is BOOL, and description is 'Limit CV in manual mode request. If Manual mode and CVManLimiting are true, CV is limited by the CVHLimit and CVLLimit values. Default is false.'</p>	 <p>The screenshot shows the 'PPID Properties - PPID' dialog box with the 'Parameters' tab selected. A table lists various parameters. The 'Cfg_SkipCVManLim' parameter is highlighted in blue. Its value is 1, type is BOOL, and description is '1 = Skip CV clamping in Manual loop mode and for CV from shed, 0 = Always apply CV clamping.'</p>
 <p>The screenshot shows the 'PPID Properties - PPID_01' dialog box with the 'Scaling limits' tab selected. Under the 'Rate of change limits' section, the checkbox 'Skip CV clamping in manual or CV shed' is checked and highlighted with a red box. Other parameters like 'CV limits' and 'SP limits' are also visible.</p>	

Differences In Control Variable Related Inputs

Some CV-related inputs are handled differently in the PPID instruction than in the PIDE instruction. The following inputs are in % of span in the PIDE while their equivalent PPID inputs are in CV EU units.

PIDE Input	PPID Input
CVProg	PSet_CV
CVOper	OSet_CV
CVOverride	Inp_OvrCV
CVPrevious	Inp_CVPrev
FF	Inp_FF
FFPrevious	Inp_FFPrev
HandFB	Inp_HandFdbk

To get the same behavior, the original value entering PIDE instruction must be converted to CV EU units before entering PPID instruction as follows.

$$\text{PPID_Input (EU)} = \text{CVEUMin} + \text{PIDE_Input (\%)} * (\text{CVEUMax} - \text{CVEUMin})/100$$

Override is slightly different in the PPID instruction compared to the PIDE instruction:

- Both instructions use Override parameters in the instruction properties.
- The PPID instruction also uses an Override command source in the instruction properties.

To get the same behavior, use the following settings.

If PIDE.ProgOverrideReq = 1, set PPID.Inp_Ovr = 1 and Inp_OverCmd = 1. PIDE.CVOverride is in % while PPID.Inp_OvrCV is in EU units. So the original CVOverride value must be converted to CV EU units.

$$\text{Inp_OvrCV (EU)} = \text{CVEUMin} + \text{CVOverride (\%)} * (\text{CVEUMax} - \text{CVEUMin})/100$$

The PIDE instruction Override parameters are defined as follows.

Table 37 - PIDE Instruction Override Parameters

Parameter		Description
Name	Type	
CVOverride	Input	CV override value. CV equals this value when in override mode. This value should correspond to a safe state output of the PID loop. If CVOverride < 0 or >100, the instruction sets the appropriate bit in Status and limits the CV value. Valid = 0.0...100.0 Default = 0.0
ProgOverrideReq	Input	Program override mode request. Set to true by the user program to request Override mode. When ProgValueReset is true, the instruction clears this input to false at each execution. Default is false.
Override	Output	Override mode indicator. Set to true when in the Override mode.
CVOverrideInv	Output	CVOverride < 0 or CVOverride > 100. The instruction limits the value for CV.

The PPID instruction Override parameters are defined as follows.

Table 38 - PPID Instruction Override Parameters

Parameter		Description
Name	Type	
Inp_OvrD	Input	1 = Acquire Override (higher priority program logic) 0 = Release Override. Default is false.
Inp_OvrDCmd	Input	Loop mode command in Override: 0 = None, 1 = Manual, 2 = Auto, 3 = Cascade, 4 = Normal, 5 = Start SP ramp, 6 = Stop SP ramp. Default is 0.
Inp_OvrDSP	Input	Loop Auto SP in Override (PVEU). Valid any float. Default is 0.0.
Inp_OvrDSPTarget	Input	Override setting for SP target in ramp wizard (PVEU). Valid any float. Default is 0.0.
Inp_OvrSPRampTime	Input	Override setting for time to reach SP target in ramp wizard (seconds). Valid = 0.0...28800.0 seconds. Default is 0.0.
Inp_OvrRatio	Input	Loop Ratio in Override (unitless). Valid = 0.0 to maximum positive float. Default is 1.0.
Inp_OvrCV	Input	Loop Manual CV in Override (CVEU). Valid any float. Default is 0.0.
Cfg_SetTrackOvrHand	Input	1 = Program/Operator/External settings track Override/Hand inputs (CV, SP, Ratio). Default is false.
Cfg_OvrOverLock	Input	1 = Override supersedes Program/Operator Lock, 0 = Do not override Lock. Default is true.
Cfg_OvrIntlk	Input	1 = Override bypasses (ignores) bypassable interlocks. 0 = Override abides by all interlock conditions. Default is false.
Sts_OvrD	Output	1 = Override is selected, supersedes Ext, Prog, Oper.

You monitor Override parameters as shown.

Table 39 - Override Parameters

PIDE Instruction - Override Parameters

Val	Name	Value	Type	Description
<input type="checkbox"/>	CVOver	0.0	REAL	CV Operator Manual value. CV is set to this value when CV is in manual mode.
<input checked="" type="checkbox"/>	CVOverride	0.0	REAL	CV Override value. CV set to this value when CV is in manual mode.
<input type="checkbox"/>	CVPrevious	0.0	REAL	CVn-1 initialization value. If CVSetPrevious is TRUE, set CV to this value.
<input type="checkbox"/>	CVSetPrevious	0	BOOL	CVn-1 initialization request. If TRUE, set CV to this value.
<input type="checkbox"/>	CVManLimiting	0	BOOL	Limit CV in manual mode request. If Manual Limiting is enabled, CV is limited to the value of CVLimit.
<input type="checkbox"/>	CVEUMax	100.0	REAL	Maximum value of CVEU. The value of CVEU cannot exceed this value.
<input type="checkbox"/>	CVEUMin	0.0	REAL	Minimum value of CVEU. The value of CVEU cannot be less than this value.
<input type="checkbox"/>	CVHLimit	100.0	REAL	CV high limit value. This is used to set the CV high limit.
<input type="checkbox"/>	CVLLimit	0.0	REAL	CV low limit value. This is used to set the CV low limit.
<input type="checkbox"/>	CVROCLimit	0.0	REAL	CV rate of change limit, in percent per second.
<input type="checkbox"/>	FF	0.0	REAL	Feed forward value. The value of feed forward is added to the CV output.
<input type="checkbox"/>	FFPrevious	0.0	REAL	FFn-1 initialization value. If FFSetPrevious is TRUE, set FF to this value.
<input type="checkbox"/>	FFSetPrevious	0	BOOL	FFn-1 initialization request. If TRUE, set FF to this value.
<input checked="" type="checkbox"/>	HandFB	0.0	REAL	CV HandFeedback value. CV set to this value when HandFB is enabled.
<input type="checkbox"/>	HandFBFault	0	BOOL	HandFB value bad health indicator. If the value is TRUE, the HandFB value is not used.

PPID - Override Command Source and Parameters

PPID Properties - PPID

Status: Hand Out of Service Maintenance **Override** External Program Operator

Source configuration: Program Operator Operator Lock

Exceptions: Loop mode ownership: Follow source; SP ownership: Follow source; CV ownership: Follow source; Ratio ownership: Follow source

Val	Name	Value	Type	Description
<input type="checkbox"/>	Inp_HandFBBad	0	BOOL	1 = CV hand feedback quality or CV hand feedback I/O communications status is bad.
<input checked="" type="checkbox"/>	Inp_Override	0	BOOL	1 = Acquire Override (higher priority program logic), 0 = Release Override.
<input type="checkbox"/>	Inp_OverrideCmd	0	SINT	Loop mode command in Override: 0 = None, 1 = Manual, 2 = Auto, 3 = Cascade.
<input type="checkbox"/>	Inp_OverrideSP	0.0	REAL	Loop Auto SP in Override (PVEU). Valid any float.
<input type="checkbox"/>	Inp_OverrideSPTarget	0.0	REAL	Override setting for SP target in ramp wizard (PVEU). Valid any float.
<input type="checkbox"/>	Inp_OverrideSPRampTime	0.0	REAL	Override setting for time to reach SP target in ramp wizard (seconds). Valid = 0.0 to 65535.0.
<input type="checkbox"/>	Inp_OverrideRatio	1.0	REAL	Loop Ratio in Override (unitless). Valid = 0.0 to maximum positive float.
<input type="checkbox"/>	Inp_OverrideCV	0.0	REAL	Loop Manual CV in Override (CVEU). Valid any float.
<input type="checkbox"/>	Inp_ExtInh	0	BOOL	1 = Inhibit External acquisition, 0 = Allow External acquisition.
<input checked="" type="checkbox"/>	Inp_Reset	0	BOOL	1 = Reset shed latches and latched alarms whose conditions have returned to normal.
<input type="checkbox"/>	Cfg_AllowDisable	1	BOOL	1 = Allow Maintenance to disable alarms.
<input type="checkbox"/>	Cfg_AllowShelve	1	BOOL	1 = Allow Operator to shelve alarms.
<input type="checkbox"/>	Cfg_HasRatio	0	BOOL	1 = Cascade loop mode is Ratio, 0 = Cascade loop mode is Cascade.
<input type="checkbox"/>	Cfg_HasCasc	0	BOOL	1 = Enable the loop to be placed into Cascade/Ratio mode.
<input type="checkbox"/>	Cfg_HasAuto	1	BOOL	1 = Enable the loop to be placed into Auto mode.
<input type="checkbox"/>	Cfg_HasMan	1	BOOL	1 = Enable the loop to be placed into Manual mode.
<input type="checkbox"/>	Cfg_HasSPRamp	0	BOOL	1 = Enable the SP ramp wizard function.

Differences in Operator Mode

In the PIDE instruction, operator mode related members are standard input parameters. In the PPID instruction, operator mode related members are private members that are not accessible in Logix Designer application. Their primary purpose is to be connected to operator faceplate objects.

PIDE instruction Operator inputs can be used in Logix program. In such a situation, a different setup should be implemented for PPID, for example, using External mode. For more information, see the PPID instruction help for details.

The PIDE instruction Operator parameters are defined as follows.

Table 40 - PIDE Instruction Input Parameters Related to Operator Mode

Parameter	Description
SPOper	SP operator value, which is scaled in PV units. SP is set to this value when in Operator control and not Cascade/Ratio mode. If the value of SPOper < SPLLimit or > SPHLimit, the instruction sets the appropriate bit in Status and limits the value that is used for SP. Valid = SPLLimit to SPHLimit Default = 0.0
RatioOper	Ratio operator multiplier. Ratio is set equal to this value when in Operator control. If RatioOper < RatioLLimit or > RatioHLimit, the instruction sets the appropriate bit in Status and limits the value that is used for Ratio. Valid = RatioLLimit to RatioHLimit. Default = 1.0
CVOper	CV operator manual value. CV equals this value when in Operator Manual mode. If not Operator Manual mode, the instruction sets CVOper = CV at the end of each instruction execution. If CVOper < 0 or > 100, or < CVLLimit or > CVHLimit when CVManLimiting is true, the instruction sets the appropriate bit in Status and limits the CV value. Valid = 0.0...100.0. Default = 0.0
OperProgReq	Operator program request. Set to true by the operator interface to request Program control. The instruction clears this input to false at each execution. Default is false.
OperOperReq	Operator operator request. Set to true by the operator interface to request Operator control. The instruction clears this input to false at each execution. Default is false.
OperCasRatReq	Operator cascade/ratio mode request. Set to true by the operator interface to request Cascade/ Ratio mode. The instruction clears this input to false at each execution. Default is false.
OperAutoReq	Operator auto mode request. Set to true by the operator interface to request Auto mode. The instruction clears this input to false at each execution. Default is false.
OperManualReq	Operator manual mode request. Set to true by the operator interface to request Manual mode. The instruction clears this input to false at each execution. Default is false.

The PPID instruction Operator parameters are defined as follows.

Table 41 - PPID Instruction Private Input Parameters Related to Output Mode

Parameter	Description
OSet_Ratio	Operator setting for Ratio, loop mode Cascade/Ratio and Ratio enabled (unitless). Valid = 0.0 to maximum positive float. Default is 1.0.
OSet_SP	Operator setting for Setpoint, loop mode Auto (PVEU). Valid any float. Default is 0.0.
OSet_CV	Operator setting for CV, loop mode Manual (CVEU). Valid any float. Default is 0.0.
OCmd_Oper	Operator command to select Operator (Program to Operator). The instruction clears this operand automatically. Default is 0.
OCmd_Prog	Operator command to select Program (Operator to Program). The instruction clears this operand automatically. Default is 0.
OCmd_Auto	Operator command to select Automatic loop mode. The instruction clears this operand automatically. Default is 0.
OCmd_Casc	Operator command to select Cascade/Ratio loop mode. The instruction clears this operand automatically. Default is 0.
OCmd_Man	Operator command to select Manual loop mode. The instruction clears this operand automatically. Default is 0.

You monitor Operator parameters as shown.

Table 42 - Operator Parameters

PIDE Instruction - Operator Parameters

Vis	Name	Value	Type	Description
<input type="checkbox"/>	ProgOverrideReq	0	BOOL	Program-Override mode request. Set TRUE by...
<input type="checkbox"/>	ProgHandReq	0	BOOL	Program-Hand mode request. Set TRUE by...
<input type="checkbox"/>	OpenProgReq	0	BOOL	Operator Program Request. Set TRUE by t...
<input type="checkbox"/>	OpenOperatorReq	0	BOOL	Operator Operator Request. Set TRUE by t...
<input type="checkbox"/>	OpenCascadeReq	0	BOOL	Operator-Cascade/Ratio mode request. Set...
<input type="checkbox"/>	OpenAutoReq	0	BOOL	Operator-Auto mode request. Set TRUE by...
<input type="checkbox"/>	OpenManualReq	0	BOOL	Operator-Manual mode request. Set TRUE b...
<input type="checkbox"/>	ProgValueReset	0	BOOL	Reset Program control values. When TRU...
<input type="checkbox"/>	TimingMode	0	DINT	Selects time base execution mode.
<input type="checkbox"/>	OversampleDT	0.0	REAL	Execution time for Oversample mode.
<input type="checkbox"/>	RSTTime	0	DINT	Module update period for Real Time Sampl...
<input type="checkbox"/>	RSTTimeStamp	0	DINT	Module time stamp value for Real Time Sa...
<input type="checkbox"/>	AcquireAcquire	0	BOOL	Acquire PIDE.AcquireData request.
<input type="checkbox"/>	AcquireStart	0	BOOL	Use Autotune request.
<input type="checkbox"/>	AcquireUseGains	0	BOOL	Use Autotune gains request.

Vis	Name	Value	Type	Description
<input type="checkbox"/>	SPOper	0.0	REAL	SP Operator value, scaled in PV units. SP
<input type="checkbox"/>	SPCascade	0.0	REAL	SP Cascade value, scaled in PV units. If C...
<input type="checkbox"/>	SPHLimit	100.0	REAL	SP high limit value, scaled in PV units.
<input type="checkbox"/>	SPLLimit	0.0	REAL	SP low limit value, scaled in PV units.
<input type="checkbox"/>	UseRatio	0	BOOL	Allow Ratio control permissive. Set TRUE i...
<input type="checkbox"/>	RatioProg	1.0	REAL	Ratio Program multiplier, no units (i.e. scala...
<input type="checkbox"/>	RatioOper	1.0	REAL	Ratio Operator multiplier, no units (i.e. scala...
<input type="checkbox"/>	RatioHLimit	1.0	REAL	Ratio high limit value, no units (i.e. scala...
<input type="checkbox"/>	RatioLLimit	1.0	REAL	Ratio low limit value, no units (i.e. scala...
<input type="checkbox"/>	CVFault	0	BOOL	Control variable bad health indicator. If CV...
<input type="checkbox"/>	CVInitReq	0	BOOL	CV initialization request. This signal will nor...
<input type="checkbox"/>	CVInitValue	0.0	REAL	CVEU initialization value, scaled in CVEU u...
<input type="checkbox"/>	CVProg	0.0	REAL	CV Program-Manual value. CV is set to thi...
<input type="checkbox"/>	CVOper	0.0	REAL	CV Operator-Manual value. CV is set to thi...
<input type="checkbox"/>	CVOverride	0.0	REAL	CV Override value. CV set to this value wh...

PPID - Operator Parameters Fields

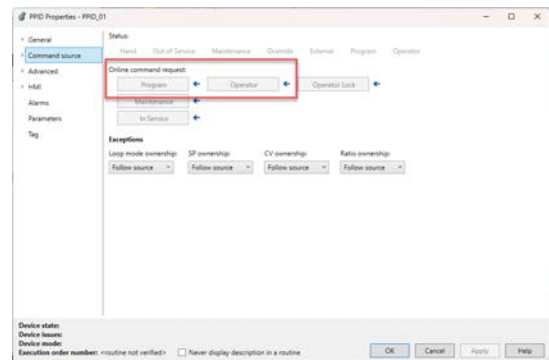
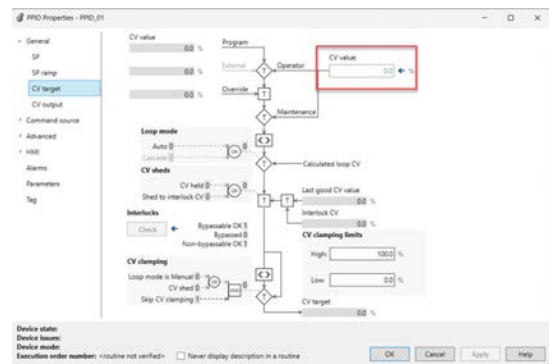
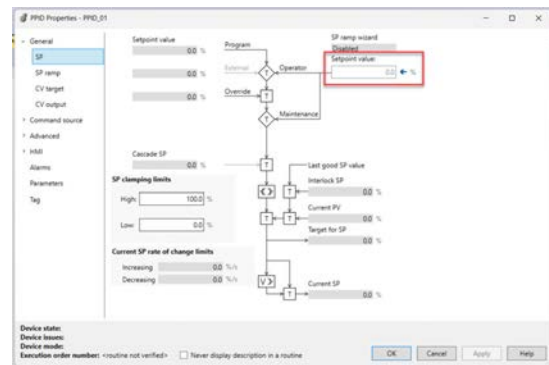
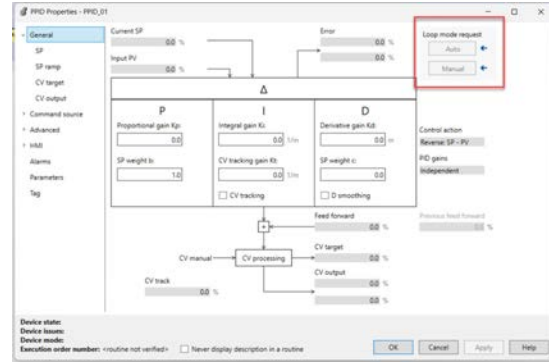

Differences in Cascade

The cascade mode behaves slightly differently in the PPID instruction than in the PIDE instruction.

PPID uses `Inp_CascSP` instead of `SPCascade` in the PIDE instruction. To enable Cascade mode, set `Cfg_HasCasc` instead of `AllowCasRat` in the PIDE instruction. To select Cascade mode use `PCmd_Casc`, `OCmd_Casc` or `XCmd_Casc` instead of `ProgCasRat` or `OperCasRat` in the PIDE instruction.

Use `Cfg_HasRatio` instead of `UseRatio` and `PSet_Ratio`, `OSet_Ratio` or `XSet_Ratio` instead of `RatioProg` and `RatioOper` in the PIDE instruction.

Windup in the PPID instruction is handled by `Sts_WindupLo` and `Sts_WindupHi` connected to `Inp_WindupLo` and `Inp_WindupHi` analogously to use of `WindupLOut`, `WindupHOut`, `WindupLIn`, and `WindupHIn` in the PIDE instruction.

To ensure bumpless transfer, the outer loop CV tracks the inner loop SP when the inner loop does not accept the cascade SP. This is implemented by connecting `Sts_CascAvailable` and `Val_SP` from the inner loop with `Inp_InnerAvailable` and `Inp_CVTrack` from the outer loop. This mechanism replaces connection of `InitPrimary` and `SP` with `CVInitReq` and `CVInitValue` in the PIDE instruction.

The Cascade mode is indicated by `Sts_Cas` instead of `CasRat` in the PIDE instruction.

For more information, and examples, see the online help for the PPID instruction.

Differences in PV Clamping

The PV value outside EU limits is handled differently in the PPID instruction than in the PIDE instruction. Any PV value outside the PV EU scaling limits is clamped by the EU limits in the PPID instruction so the percentage value `Val_PVPercent` used for CV output calculation is always between 0% and 100%.

The PIDE does not clamp the PV value and therefore the percentage value `PVPercent` can be outside the 0% and 100% range. If your PIDE was designed so that PV value regularly exceeds EU limits, then you must extend PV limits when converting to PPID.

Keep in mind that when changing EU scaling limits, PID gains must be changed accordingly to get equivalent output calculation. Conversion formulas are as follows.

$$\text{Gain}_{\text{new}} = \text{Gain}_{\text{old}} * (\text{PVEUMax}_{\text{new}} - \text{PVEUMin}_{\text{new}}) / (\text{PVEUMax}_{\text{old}} - \text{PVEUMin}_{\text{old}})$$

Differences in Control Variable Scaling and Limits Configuration

There are two differences between parameters related to CV scaling and limits in the PIDE and PPID instructions.

- CV high and low limits are set in percent in the PIDE instruction and in EU in the PPID instruction.
- In the PIDE instruction, it is allowed to set CVEUMax to be less than CVEUMin.

CV scaling parameters and limits in the PPID instruction should be set in the following way based on the corresponding PIDE instruction parameters, depending on the configuration of CVEUMin and CVEUMax parameters in the PIDE instruction.

If $CVEUMin < CVEUMax$, then set the parameters of the PPID instruction as follows:

- $Cfg_CVEUMin = CVEUMin$
- $Cfg_CVEUMax = CVEUMax$
- $Cfg_CtrlAction = ControlAction$
- $Cfg_CVLoLim = CVEUMin + CVLLimit (\%) * (CVEUMax - CVEUMin)/100$
- $Cfg_CVHiLim = CVEUMin + CVHLimit (\%) * (CVEUMax - CVEUMin)/100$

If $CVEUMin > CVEUMax$, then set the parameters of the PPID instruction as follows:

- $Cfg_CVEUMin = CVEUMax$
- $Cfg_CVEUMax = CVEUMin$
- $Cfg_CtrlAction = \text{inverse of ControlAction}$
- $Cfg_CVLoLim = CVEUMin - CVHLimit (\%) * (CVEUMin - CVEUMax)/100$
- $Cfg_CVHiLim = CVEUMin - CVLLimit (\%) * (CVEUMin - CVEUMax)/100$

The CV output in engineering units in the PPID instruction parameter Val_CVOut will be equal to CVEU in the PIDE instruction, but CV in percent Val_CVOutPercent will be equal to $100 - CV$.

Autotuning is Not Available In the PPID Instruction

With Logix Designer application, version 38.00.00, the PPID instruction does not support Autotuning.

We recommend that you use third-party tuning software when performing tuning in the PPID instruction.

History of Changes

This appendix contains the new or updated information for each revision of this publication. These lists include substantive updates only and are not intended to reflect all changes. Translated versions are not always available for each revision.

Change Log

1756-RM100L-EN-P, November 2022

Change

Added GuardLogix XT catalog numbers

Updated unconnected message buffers information

Updated Minor Fault on Overflow

1756-RM100K-EN-P, March 2022

Change

Added in support for FLEX 5000[®] I/O Page

Added FactoryTalk[®] Logix Echo ControlLogix 5580

Added SFC Reset Affect on Active Step

Updated the redundant systems Product Comparisons table with support for Gigabit Ethernet and CIP Security™

1756-RM100J-EN-P, December 2020

Change

Add Controller Memory Usage

1756-RM100I-EN-P, December 2020

Change

Added ControlLogix 5580 and Compact Logix 5380 Process controller catalog numbers.

Added ControlLogix 5580 No Stored Energy (NSE) and ControlLogix-XT 5580 controllers catalog numbers.

Added Firmware Upgrade Guidelines for Safety Controllers.

Added Replacement Considerations with Redundant Systems.

1756-RM100H-EN-P, May 2020

Change

Added information regarding Compact GuardLogix 5380 SIL 3 controllers.

Additional Resources moved to a new page.

1756-RM100G-EN-P, October 2019**Change**

Corrected number of supported axes for 5380 controller (supported number is 32).

Added Appendix A: Replacement Considerations for 1768-L4 and 1769-L3 Controllers

1756-RM100F-EN-P, October 2018**Change**

Added information regarding GuardLogix 5580 and Compact GuardLogix 5380 controllers.

Added Chapter 4: Replacement Considerations with Safety Applications

Added information on the AXIS_CIP_Drive Data Type for Studio 5000 Logix Designer® V31.00.00

1756-RM100E-EN-P, December 2016**Change**

Additional new features and future features

Information about the 5069-L350ERM, 5069-L380ERM, and 5069-L3100ERM controllers

1756-RM100D-EN-P, September 2016**Change**

New and Future Features in Studio 5000 Logix Designer

Replacement Considerations with CompactLogix Systems

EtherNet/IP Modes with CompactLogix 5380 controllers

Late Binding of I/O Data

I/O Data Manipulation

Diagnostics and Status Indicators with CompactLogix Systems

Examples of CompactLogix 5380 System Configurations

1756-RM100C-EN-P, November 2015**Change**

Updated the Axes/ms over EtherNet/IP port specification

1756-RM100B-EN-P, November 2015**Change**

Added product comparison between ControlLogix 5580 and ControlLogix 5570 controllers

Added controller dimension information

Added connector and status indicator information

Added information on how to configure the controller

Added controller reset button information

Added communication options information

Removed installation information

Numerics

10/100/1000 Mbps

EtherNet/IP network communication rates
23, 25, 27, 53, 55, 57, 81, 82, 84,
209

4-character display

Compact GuardLogix 5380 controller 194
CompactLogix 5380 controller 194
ControlLogix 5580 controller 179
ControlLogix 5590 controller 179
GuardLogix 5580 controller 179

A

add-on instruction

does not propagate math status flags 168
InOut parameters 155
maximum InOut parameters 155
nested 168
nesting level limit 155

Advanced Diagnostics web page

Compact GuardLogix 5380 controller 203
CompactLogix 5380 controller 203
ControlLogix 5580 controller 190
ControlLogix 5590 controllers 190
GuardLogix 5580 controller 190

AND 148

array 175, 177

atomic data type 175

auto-negotiate 42, 71

AVE

instruction accuracy 163

axes 25, 28, 56, 58, 83, 85, 207, 209

CIP 141, 142
consumed 141
virtual 141

Axis Safety Fault tags 143

AXIS_CIP_DRIVE data type 143

B

behavior

DINT 150

binary files

Logix Designer application 50, 112

BTD

does not generate math status 164

build button 50, 112

C

cached messages 23, 81

ControlLogix 5580 controllers 53
ControlLogix 5590 controllers 53

carry flag 170

CMP

does not generate math status 164

communication

allow

Compact GuardLogix controller 105
CompactLogix controller 105
ControlLogix controllers 49
GuardLogix controllers 49

block

Compact GuardLogix controller 105
CompactLogix controller 105
ControlLogix controller 49
GuardLogix controller 49

connections 33, 94

communication options

Compact GuardLogix 5370 L3 controller 104
Compact GuardLogix 5380 controller 104,
220

CompactLogix 1768-L4 controller 220

CompactLogix 1769-L3 controller 220

CompactLogix 5370 L3 controller 104

CompactLogix 5380 controller 104

ControlLogix 5570 controllers 48, 76

ControlLogix 5580 controllers 48, 76

ControlLogix 5590 controllers 76

GuardLogix 5570 controllers 48, 76

GuardLogix 5580 controllers 48, 76

communication throughput 49, 105

Compact GuardLogix 1768-L4

dimensions 214

Compact GuardLogix 1768-L4 controller 210

connectors 217

controller spacing 211

status indicators 215

Compact GuardLogix 5370 L3 controller

allow communication 105

block communication 105

communication options 104

connectors 91

dimensions 88

status indicators 90

Compact GuardLogix 5380 controller

- allow communication 105
- block communication 105
- communication options 104, 220
- configure the controller 94
- connectors 91, 92, 217
- controller spacing 87, 212
- dimensions 89, 215
- EtherNet/IP indicators 196
- EtherNet/IP modes 106
- EtherNet/IP nodes supported 94
- properties 96, 98
 - Advanced tab 97
 - Capacity tab 100
 - Security tab 101
- reset button 102
- status indicators 90, 196, 215
 - 4-character display 194
- web pages 198

Compact GuardLogix controllers

- minimum requirements 82, 205
- product comparison 84, 209

CompactLogix 1768-L4 controller 208

- communication options 220
- connectors 215
- controller spacing 211
- dimensions 213
- EtherNet/IP communication 220
- nonvolatile memory 219
- power 218
- serial communication 221
- status indicators 215

CompactLogix 1769-L3 controller

- communication options 220
- connectors 215
- controller spacing 211
- dimensions 213
- EtherNet/IP communication 220
- nonvolatile memory 219
- power 218
- serial communication 221
- status indicators 215

CompactLogix 5370 L3 controller

- allow communication 105
- block communication 105
- communication options 104
- connectors 90
- dimensions 87
- status indicators 90

CompactLogix 5380 controller

- allow communication 105
- block communication 105
- communication options 104, 220
- configure the controller 94
- connectors 90, 216

- controller spacing 86, 212
- dimensions 88, 214
- EtherNet/IP indicators 196
- EtherNet/IP modes 106
- EtherNet/IP nodes supported 94
- properties 96
 - Advanced tab 97
 - Capacity tab 100
 - Memory tab 99
 - Project tab 98
 - Security tab 101
- reset button 102
- status indicators 90, 196, 215
 - 4-character display 194
- web pages 198

CompactLogix controllers

- minimum requirements 82, 205
- product comparison 82, 206

connections 33, 94**connectors**

- Compact GuardLogix 1768-L4 controller 217
- Compact GuardLogix 5370 L3 controller 91
- Compact GuardLogix 5380 controller 91, 92, 217
- CompactLogix 1768-L4 controller 215
- CompactLogix 1769-L3 controller 215
- CompactLogix 5370 L3 controller 90
- CompactLogix 5380 controller 90, 216
- GuardLogix 5570 controller 32
- GuardLogix 5580 controller 32

controller behavior

- Compact GuardLogix controllers 105
- CompactLogix controllers 105

controller spacing

- Compact GuardLogix 1768-L4 controller 211
- Compact GuardLogix 5380 controller 87, 212
- CompactLogix 1768-L4 controller 211
- CompactLogix 1769-L3 controller 211
- CompactLogix 5380 controller 86, 212

controller web pages

- Advanced Diagnostics web page 190
 - Compact GuardLogix 5380 controller 203
 - CompactLogix 5380 controller 203
 - ControlLogix 5580 controller 190
 - ControlLogix 5590 controller 190, 191
 - GuardLogix 5580 controller 190
- Diagnostics web page
 - Compact GuardLogix 5380 controller 201
 - CompactLogix 5380 controller 201
 - ControlLogix 5580 controller 188
 - ControlLogix 5590 controller 188
 - GuardLogix 5580 controller 188

- Ethernet Port A1/A2 web page
 - Compact GuardLogix 5380 controller 202
 - CompactLogix 5380 controller 202
 - Ethernet Port web page
 - ControlLogix 5590 controller 189
 - Faults web page
 - ControlLogix 5580 controller 186
 - ControlLogix 5590 controller 186
 - Home web page
 - Compact GuardLogix 5380 controller 199
 - CompactLogix 5380 controller 199
 - ControlLogix 5580 controller 184
 - ControlLogix 5590 controller 185
 - GuardLogix 5580 controller 184
 - Tasks web page
 - Compact GuardLogix 5380 controller 200
 - CompactLogix 5380 controller 200
 - ControlLogix 5580 controller 187
 - ControlLogix 5590 controller 187
 - GuardLogix 5580 controller 187
 - ControlLogix 5570 controller**
 - allow communication 49
 - block communication 49
 - dimensions 29
 - status indicators 31
 - supported networks 48, 76
 - ControlLogix 5580 controller**
 - allow communication 49
 - block communication 49
 - configure the controller 33
 - diagnostics and status indicators 179
 - dimensions 29, 59
 - EtherNet/IP indicators 182
 - EtherNet/IP nodes supported 33
 - properties 36, 64
 - Advanced tab 37, 44
 - Capacity tab 39
 - Internet Protocol tab 41
 - Memory tab 38
 - Port Configuration tab 42
 - Port Diagnostics 43
 - Security tab 43
 - reset button 46
 - status display 179
 - status indicators 31, 61, 181
 - 4-character display 179
 - supported networks 48, 76
 - web pages 183
 - ControlLogix 5590 controller**
 - configure the controller 63
 - diagnostics and status indicators 179
 - dimensions 60
 - EtherNet/IP indicators 182
 - EtherNet/IP modes 77
 - properties 64
 - Capacity tab 69
 - General tab 65
 - Internet Protocol tab 70
 - Major Faults tab 66
 - Network tab 73
 - Port Configuration tab 71
 - Port Diagnostics 72
 - Redundancy tab 67
 - Safety tab 68
 - Security tab 74
 - status display 179
 - status indicators 61, 181
 - 4-character display 179
 - supported networks 76
 - ControlLogix 5590 controller web pages** 183
 - ControlLogix controllers**
 - minimum requirements 24, 54
 - product comparison 24, 55
 - SD card 47
 - Converting +/- Infinity** 172
 - COP** 173
 - copy/file instructions** 173, 177
 - COP and CPS into structures 173
 - JSR passing atomic data type into array 175
 - JSR passing atomic data type into structure 175
 - JSR passing into structures 174
 - RET parameters passing into structures 174
 - CPS** 173
 - current speed** 42, 71
- ## D
- DataTablePadPercentage** 178
 - diagnostics**
 - with the Logix Designer application 43, 72
 - Diagnostics web page**
 - Compact GuardLogix 5380 controller 201
 - CompactLogix 5380 controller 201
 - ControlLogix 5580 controller 188
 - ControlLogix 5590 controller 188
 - GuardLogix 5580 controller 188

dimensions

- Compact GuardLogix 1768-L4 controller 214
- Compact GuardLogix 5370 L3 controller 88
- Compact GuardLogix 5380 controller 89, 215
- CompactLogix 1768-L4 controller 213
- CompactLogix 1769-L3 controller 213
- CompactLogix 5370 L3 controller 87
- CompactLogix 5380 controller 88, 214
- ControlLogix 5570 controller 29
- ControlLogix 5580 controller 29, 59
- ControlLogix 5590 controller 60
- GuardLogix 5570 controller 30
- GuardLogix 5580 controller 30, 59

distributed I/O

- Compact GuardLogix controllers 104
- CompactLogix controllers 104
- ControlLogix controllers 48, 76
- GuardLogix controllers 48, 76

Dual-IP mode 77, 106**duplex** 42, 71**E****Ethernet A1/A2 ports**

- Dual-IP mode 77, 106
- Linear/DLR mode 78, 107
- web page 202

Ethernet port

- Compact GuardLogix 5380 controller 81
- CompactLogix 5380 controller 81
- ControlLogix 5580 controller 23, 53
- ControlLogix 5590 controller 53
- GuardLogix 5580 controller 23, 53
- speed changes 53, 81

Ethernet Port web page

- ControlLogix 5590 controller 189

EtherNet/IP communication

- CompactLogix 1768-L4 controller 220
- CompactLogix 1769-L3 controller 220

EtherNet/IP modes

- Compact GuardLogix 5380 controller 106
- CompactLogix 5380 controller 106
- ControlLogix 5590 controller 77
- Dual-IP mode 77, 106
- Linear/DLR mode 78, 107

EtherNet/IP network

- available network communication rates 23, 25, 27, 53, 55, 57, 81, 82, 84, 209

EtherNet/IP status indicators

- Compact GuardLogix 5380 controller
 - LINK A1 and LINK A2 indicators 196
 - NET A1 and NET A2 indicators 196
- CompactLogix 5380 controller
 - LINK A1 and LINK A2 indicators 196
 - NET A1 and NET A2 indicators 196

execution

- structural 152

F**FAL**

- does not generate math status 164

fault

- cpu temperature 51, 79, 113
- hardware preservation 51, 79, 113
- recoverable 51, 79, 113

faults

- minor overflow 37, 97, 166

Faults web page

- ControlLogix 5580 controller 186
- ControlLogix 5590 controller 186

floating point literals 150**FSC**

- does not generate math status 164

G**GSV** 117**GuardLogix 5570 controller**

- allow communication 49
- block communication 49
- connectors 32
- dimensions 30
- status indicators 31
- supported networks 48, 76

GuardLogix 5580 controller

- allow communication 49
- block communication 49
- configure the controller 33
- connectors 32
- diagnostics and status indicators 179
- dimensions 30, 59
- EtherNet/IP indicators 182
- EtherNet/IP nodes supported 33
- properties 36, 64

- Advanced tab 37, 44

- Capacity tab 39

- Internet Protocol tab 41

- Port Configuration tab 42

- Port Diagnostics 43

- Security tab 43

- reset button 46

- status display 179

- status indicators 31, 61, 181
 - 4-character display 179

- supported networks 48, 76

- web pages 183

GuardLogix 5590 controller

- properties

- Capacity tab 69

GuardLogix controllers

- minimum requirements 24, 54

- product comparison 26

- SD card 47

GuardLogix controllers/ControlLogix 5590 controllers

- product comparison 57

H**Home web page**

Compact GuardLogix 5380 controller 199
 CompactLogix 5380 controller 199
 ControlLogix 5580 controller 184
 ControlLogix 5590 controller 185
 GuardLogix 5580 controller 184

I

import project 50, 112

InOut parameters

maximum number for AIOs 155

instruction

ACOS 147
 ACS 147
 ADD 170
 ASIN 147
 ASN 147
 ATAN 147
 ATN 147
 AVE 163, 177
 BRK 169
 BSL 177
 BSR 177
 BTD 164
 CMP 164, 171
 COP 173
 COS 147
 CPS 173
 CPT 161
 DDT 177
 DIV 152
 EQU 171
 FAL 164
 FBC 177
 FFL 177
 FFU 177
 FOR 169
 FSC 164
 GEQ 171
 GRT 171
 GSV 178
 JSR 153, 154, 169, 174, 175
 LBL 156
 LEQ 171
 LES 171
 LFL 177
 LFU 177
 LN 147
 LOG 147
 MAG 150
 MAJ 150
 MAM 150
 MAPC 150
 MCR 157

MEQ 150
 MOD 148
 NEQ 171
 OTE 167
 OTL 167
 RET 154, 169, 174
 SBR 154, 169, 175
 SIN 147
 SQL 177
 SQR 147
 SORT 147
 SRT 177
 SSV 178
 STD 163, 177
 SUB 170
 TAN 147
 TOD 168
 TRN 146, 161
 XPY 147, 151

instruction error and fault changes

AIOs do not propagate math status flags 168
 AVE and STD instruction accuracy 163
 BTD, FAL, FSC, CMP do not generate math status 164
 carry flag 170
 compare NAN values 171
 manually set math overflow 167
 math status flags valid only in one rung 162
 minor fault on overflow 166
 no math status flags in structured text 165
 store NAN in an integer 171
 subroutines do not affect math status flags 169
 subscript expressions 160
 TOD instruction flags and math status flags 168
 TRN operator and math status flags 161

instruction set

copy/file instructions 173
 GSV/SSV instructions 178
 instruction error and fault changes 160
 math-related instructions 145
 operand changes 172
 structural changes to execution 152

instructions that operate on arrays 177**integrated motion**

Compact GuardLogix controllers 104
 CompactLogix controllers 104
 ControlLogix controllers 48, 76
 GuardLogix controllers 48, 76

IP addresses

Dual-IP mode 77, 106

J

- JSR** 174
 - max inputs or outputs 154
 - passing atomic data type into a structure 175
 - passing atomic data type into an array 175
- JSR nesting level limit** 153
- jump to label** 156

L

- Linear/DLR mode** 78, 107
- LINK A1 and LINK A2 status indicators**
 - Compact GuardLogix 5380 controller 196
 - CompactLogix 5380 controller 196
- link status** 42, 71
- LINT** 158
- Logix Designer application** 258
 - Advanced tab 37, 44, 97
 - alarm parameter differences
 - PIDE to PPID instruction migration 252
 - binary files 50, 112
 - build button 50, 112
 - Capacity tab 39, 69, 100
 - controller properties 36, 64, 95, 96
 - import project 50, 112
 - Internet Protocol tab 41, 70
 - Memory tab 38, 99
 - minor overflow faults 37, 97
 - module definition dialog box 95
 - Network tab 73
 - new project dialog box 35, 63, 95
 - PIDE and PPID control limiting parameters 258
 - PIDE and PPID control variable rate of
 - change parameters 257
 - PIDE and PPID deadband parameters 255
 - PIDE and PPID operator parameters 264
 - PIDE and PPID override parameters 261
 - Port Configuration tab 42, 71
 - auto-negotiate 42, 71
 - current speed 42, 71
 - duplex 42, 71
 - link status 42, 71
 - port diagnostics 42, 71
 - PPID timing mode parameters 253
 - project size 50, 93
 - Project tab 98
 - project upload fidelity 51, 112
 - report overflow faults 37, 97
 - Security tab 43, 74, 101
 - system overhead time slice 37, 97
 - UDT 50, 112

M

- mapping** 136, 137, 138, 158
- math overflow** 166, 167, 168
- math status flags** 161, 168, 169
 - not allowed in structured text 165
 - valid only in one rung 162
- math-related instructions** 145
 - 0.0 div 0.0 152
 - AND, NOT, OR, XOR support for REAL 148
 - floating point literals 150
 - improved math instruction accuracy 146
 - SQR/SQRT adjustment 147
 - TRN instruction changes 146
 - X Mod 0 148
 - XPY instruction 151
- MCR** 157
- memory**
 - Compact GuardLogix controllers 84, 209
 - CompactLogix controllers 82, 206
 - ControlLogix controllers 24, 55, 57
 - GuardLogix controllers 26, 57
- message**
 - buffers 23, 81
 - ControlLogix 5580 controllers 53
 - ControlLogix 5590 53
 - cached 23, 81
 - ControlLogix 5580 controllers 53
 - ControlLogix 5590 controllers 53
- minimum requirements**
 - Compact GuardLogix controllers 82, 205
 - CompactLogix controllers 82, 205
 - ControlLogix controllers 24, 54
 - GuardLogix controllers 24, 54
- minor fault on overflow** 166
- MOD power indicator**
 - Compact GuardLogix 5380 controller 197
 - CompactLogix 5380 controller 197
- module definition dialog box** 95
- motion**
 - number of axes
 - Compact GuardLogix controller 85, 209
 - CompactLogix controller 83, 207
 - ControlLogix 5590 controllers 58
 - ControlLogix controller 25, 56
 - GuardLogix controller 28, 58

N

- NAN** 152
 - compare NAN values 171
 - store NAN in an integer 171
- nesting**
 - JSR level limit 153
 - level limit for A0Is 155
- NET A1 and NET A2 status indicators**
 - Compact GuardLogix 5380 controller 196
 - CompactLogix 5380 controller 196
- new project dialog box** 35, 63, 95
- nonvolatile memory**
 - CompactLogix 1768-L4 controller 219
 - CompactLogix 1769-L3 controller 219
- NOT** 148

O

- operand changes**
 - converting +/- infinity 172
- OR** 148

P

- packet processing** 23, 81
 - ControlLogix 5580 controllers 53
 - ControlLogix 5590 controllers 53
- PIDE to PPID instruction migration**
 - alarm parameter differences 252
 - alternative input parameters 235
 - alternative output parameters 245
 - control variable manual limiting 258
 - control variable rate of change limiting 256
 - differences in alarming 248
 - differences in cascade 265
 - differences in control variable related inputs 259
 - differences in control variable scaling and limits configuration 266
 - differences in operator mode 262
 - differences in override 259
 - differences in pv clamping 265
 - equivalent input parameters 224
 - equivalent or alternative input parameters 236
 - equivalent output parameters 240
 - parameters unavailable in PPID instruction 253

- PIDE instruction
 - control limiting parameters 258
 - control variable rate of change parameters 257
 - operator parameters 264
 - override parameters 261
 - zero crossing deadband parameters 255
- PPID instruction
 - control limiting parameters 258
 - control variable rate of change parameters 257
 - operator parameters 264
 - override parameters 261
 - PV deviation deadband parameters 255
 - PPID timing mode parameters 253
 - zero crossing deadband and process variable deviation deadband 254
- port configuration category** 43, 72
- port diagnostics** 42, 71
 - with Logix Designer application 43, 72
- power status indicators**
 - Compact GuardLogix 5380 controller
 - MOD power indicator 197
 - SA power indicator 197
 - CompactLogix 5380 controller
 - MOD power indicator 197
 - SA power indicator 197
- power the controller**
 - CompactLogix 1768-L4 controller 218
 - CompactLogix 1769-L3 controller 218
- produce/consume** 48, 76, 104, 120, 220
 - safety tags 120
- product comparison**
 - Compact GuardLogix controllers 84, 209
 - CompactLogix controllers 82, 206
 - ControlLogix controllers 24, 55
 - GuardLogix controllers 26
 - GuardLogix controllers/ControlLogix 5590 controllers 57
- project size** 50, 93
- project upload fidelity** 51, 112

R

- Rads** 147
- REAL** 150
 - AND, NOT, OR, XOR support 148
 - subscript expressions 160
- redundant systems** 129
- report overflow faults** 37, 97
- reset button**
 - Compact GuardLogix 5380 controller 85, 210
 - CompactLogix 5380 controller 83, 208
 - ControlLogix 5580 controller 26, 56
 - ControlLogix 5590 controller 56
 - ControlLogix 5590 controllers 58
 - GuardLogix 5580 controller 28, 58
- RET** 174
 - max inputs or outputs 154

S

- SA power indicator**
 - Compact GuardLogix 5380 controller 197
 - CompactLogix 5380 controller 197
- safety application** 115
 - conversion 120
 - replace producer controller 127
 - with 1734-AENTR Series A modules 117
- safety attributes** 117
- safety network number** 119
- safety signature**
 - description 117
 - GSV of safety attributes 117
- safety tags** 120
 - produce/consume 120
- SBR**
 - JSR/RET max inputs or outputs 154
- SD card** 47
- serial communication**
 - CompactLogix 1768-L4 controller 221
 - CompactLogix 1769-L3 controller 221
- ShareUnusedTimeSlice** 178
- software**
 - configure the controller
 - Compact GuardLogix 5380 94
 - CompactLogix 5380 94
 - ControlLogix 5580 33
 - ControlLogix 5590 controller 63
 - GuardLogix 5580 33
 - Logix Designer application
 - Advanced tab 37, 44, 97
 - binary files 50, 112
 - Capacity tab 39, 69, 100
 - controller properties 36, 64, 96
 - import project 50, 112
 - Internet Protocol tab 41, 70
 - Memory tab 38, 99
 - Network tab 73
 - new project dialog box 35, 63, 95
 - Port Configuration tab 42, 71
 - Project tab 98
 - project upload fidelity 51, 112
 - Security tab 43, 74, 101
 - UDT 50, 112

specifications

- Ethernet 25, 27, 55, 57, 82, 84, 209
- EtherNet/IP nodes supported
 - Compact GuardLogix 5380 controller 94
 - CompactLogix 5380 controller 94
 - ControlLogix 5580 controller 33
 - ControlLogix 5590 controllers 55
 - GuardLogix 5580 controller 33
- memory
 - Compact GuardLogix controllers 84, 209
 - CompactLogix controllers 82, 206
 - ControlLogix controllers 24, 55
 - GuardLogix controllers 26, 57
- motion
 - Compact GuardLogix controllers 85, 209
 - CompactLogix controllers 83, 207
 - ControlLogix 5590 controllers 58
 - ControlLogix controllers 25, 56
 - GuardLogix controllers 28, 58
- wire category
 - Compact GuardLogix controllers 85, 210
 - CompactLogix controllers 83, 207
 - ControlLogix controllers 26, 56
 - GuardLogix controllers 28, 58
- wire size
 - Compact GuardLogix controllers 85, 210
 - CompactLogix controllers 83, 208
 - ControlLogix controllers 26, 56
 - GuardLogix controllers 28, 58
- speed change**
 - Ethernet ports 53, 81
- SQR** 147
- SQRT** 147
- status indicators**
 - Compact GuardLogix 1768-L4 controller 215
 - Compact GuardLogix 5370 L3 controller 90
 - Compact GuardLogix 5380 controller 90, 196, 215
 - LINK A1 and LINK A2 indicators 196
 - MOD power indicator 197
 - NET A1 and NET A2 indicators 196
 - SA power indicator 197
 - CompactLogix 1768-L4 controller 215
 - CompactLogix 1769-L3 controller 215
 - CompactLogix 5370 L3 controller 90
 - CompactLogix 5380 controller 90, 196, 215
 - LINK A1 and LINK A2 indicators 196
 - MOD power indicator 197
 - NET A1 and NET A2 indicators 196
 - SA power indicator 197
 - ControlLogix 5570 controller 31
 - ControlLogix 5580 controller 31, 61, 181
 - ControlLogix 5590 controller 61, 181
 - GuardLogix 5570 controller 31
 - GuardLogix 5580 controller 31, 61, 181
- STD**
 - instruction accuracy 163

structural changes to execution

- AOI nesting level limit 155
- JSR nesting level limit 153
- JSR/RET max inputs or outputs 154
- jump to label 156
- maximum InOut parameters for AOIs 155
- MCR placement 157
- UDTs that contain Lints 158

structured text

- status flags not allowed 165

subroutines

- do not affect math status flags 169

subscript expressions 160**system overhead time slice** 37, 97**T****tags**

- produce 134

Tasks web page

- Compact GuardLogix 5380 controller 200
- CompactLogix 5380 controller 200
- ControlLogix 5580 controller 187
- ControlLogix 5590 controller 187
- GuardLogix 5580 controller 187

temperature

- warning 51, 79, 113

time slice 37, 97, 178**TOD**

- instruction flags and math status flags 168

TRN

- instruction changes 146
- math status flags 161

troubleshoot

- Advanced Diagnostics web page
 - Compact GuardLogix 5380 controller 203
 - CompactLogix 5380 controller 203
 - ControlLogix 5590 controller 190
 - ControlLogix 5580 controller 190
 - ControlLogix 5590 controller 190, 191
 - GuardLogix 5580 controller 190
 - GuardLogix 5590 controller 190
- Diagnostics web page
 - Compact GuardLogix 5380 controller 201
 - CompactLogix 5380 controller 201
 - ControlLogix 5580 controller 188
 - ControlLogix 5590 controller 188
 - GuardLogix 5580 controller 188
- Ethernet Port A1/A2 web page
 - Compact GuardLogix 5380 controller 202
 - CompactLogix 5380 controller 202

- Ethernet Port web page
 - ControlLogix 5590 controller 189

- Faults web page
 - ControlLogix 5580 controller 186
 - ControlLogix 5590 controller 186

- Home web page
 - Compact GuardLogix 5380 controller 199

- CompactLogix 5380 controller 199
- ControlLogix 5580 controller 184
- ControlLogix 5590 controller 185
- GuardLogix 5580 controller 184

- Tasks web page
 - Compact GuardLogix 5380 controller 200

- CompactLogix 5380 controller 200
- ControlLogix 5580 controller 187
- GuardLogix 5580 controller 187

U**UDT** 50, 112, 158**unconnected message buffers** 23, 81

- ControlLogix 5580 controllers 53
- ControlLogix 5590 controllers 53

W**web pages** 183, 198**wire**

category

- Compact GuardLogix controllers 85, 210
- CompactLogix controllers 83, 207
- ControlLogix controllers 26, 56
- GuardLogix controllers 28, 58

size

- Compact GuardLogix controllers 85, 210
- CompactLogix controllers 83, 208
- ControlLogix controllers 26, 56
- GuardLogix controllers 28, 58

X**X Mod O** 148**XOR** 148**XPY** 151

Notes:

Rockwell Automation Support

Use these resources to access support information.

Technical Support Center	Find help with how-to videos, FAQs, chat, user forums, Knowledgebase, and product notification updates.	rok.auto/support
Local Technical Support Phone Numbers	Locate the telephone number for your country.	rok.auto/phonesupport
Technical Documentation Center	Quickly access and download technical specifications, installation instructions, and user manuals.	rok.auto/techdocs
Literature Library	Find installation instructions, manuals, brochures, and technical data publications.	rok.auto/literature
Product Compatibility and Download Center (PCDC)	Download firmware, associated files (such as AOP, EDS, and DTM), and access product release notes.	rok.auto/pcdc

Documentation Feedback

Your comments help us serve your documentation needs better. If you have any suggestions on how to improve our content, complete the form at rok.auto/docfeedback.

Waste Electrical and Electronic Equipment (WEEE)



At the end of life, this equipment should be collected separately from any unsorted municipal waste.





Rockwell Automation maintains current product environmental compliance information on its website at rok.auto/pec.

Allen-Bradley, ArmorBlock, Compact 5000, Compact I/O, CompactBlock, CompactLogix, ControlFLASH, ControlFLASH Plus, ControlLogix, ControlLogix-XT, Data Highway Plus, DH+, expanding human possibility, FactoryTalk, FLEX, FLEX 5000, FLEXHA 5000, Guard I/O, GuardLogix, GuardLogix-XT, Integrated Architecture, Kinetix, Logix 5000, PanelView, PhaseManager, PLC-2, PLC-5, POINT I/O, POINT Guard I/O, PointMax I/O, PowerFlex, Rockwell Automation, Rockwell Software, RSLogix 5000, SequenceManager, SLC, Stratix, Studio 5000, Studio 5000 Automation Engineering & Design Environment, Studio 5000 Logix Designer, and SynchLink are trademarks of Rockwell Automation, Inc.

CIP, CIP Safety, CIP Security, CIP Sync, ControlNet, DeviceNet, and EtherNet/IP are trademarks of ODVA, Inc.

Trademarks not belonging to Rockwell Automation are property of their respective companies.

Rockwell Otomasyon Ticaret A.Ş. Kar Plaza İş Merkezi E Blok Kat:6 34752, İçerenköy, İstanbul, Tel: +90 (216) 5698400 EEE Yönetmeliğine Uygundur

Connect with us.    

rockwellautomation.com — expanding human possibility®

AMERICAS: Rockwell Automation, 1201 South Second Street, Milwaukee, WI 53204-2496 USA, Tel: (1)414.382.2000

EUROPE/MIDDLE EAST/AFRICA: Rockwell Automation NV, Pegasus Park, De Kleetlaan 12a, 1831 Diegem, Belgium, Tel: (32) 2663 0600

ASIA PACIFIC: Rockwell Automation SEA Pte Ltd, 2 Corporation Road, #04-05, Main Lobby, Corporation Place, Singapore 618494, Tel: (65) 6510 6608

UNITED KINGDOM: Rockwell Automation Ltd., Pitfield, Kiln Farm, Milton Keynes, MK11 3DR, United Kingdom, Tel: (44)(1908) 838-800

Publication 1756-RM100M-EN-P - October 2025

Supersedes Publication 1756-RM100L-EN-P - November 2022

Copyright © 2025 Rockwell Automation, Inc. All rights reserved. Printed in the U.S.A.