

# Installation Instructions

Original Instructions



**Allen-Bradley**  
by ROCKWELL AUTOMATION



## 440J-N Enabling Switch

Catalog Numbers 440J-N21TNPM, 440J-N21TNPM-NP, 440J-N2NTNPM-NE

Installation must be in accordance with the following steps and stated specifications and implemented by suitably competent personnel. This device is intended to be part of the safety-related control system.

Before installation, perform a risk assessment to determine whether the specifications of this device are suitable for all foreseeable operational and environmental characteristics of the machine to which it is to be fitted.

At regular intervals during the life of the unit, check whether these characteristics foreseen remain valid. Inspect this device for evidence of accelerated wear, material degradation, or tampering. If necessary, replace the device. The manufacturer cannot accept responsibility for a failure of this device if the procedures are not implemented or if it is used outside the recommended specifications.

Adherence to the recommended maintenance instructions forms part of the warranty.



**ATTENTION:** Turn off the power to the enabling switch before installation, removal, wiring, maintenance, and inspection. Use correct size wires to meet voltage and current requirements. Tighten the terminal screws to the recommended tightening torque.



**WARNING:** Do not defeat, tamper, remove, or bypass this unit. Severe injury to personnel could result.

### Summary of Changes

This publication contains the following new or updated information. This list includes substantive updates only and is not intended to reflect all changes.

Topic	Page
Updated Operation Precautions section	1
Updated Wiring section	1
Updated Specifications section	2
Added Approximate Dimensions section	3
Updated Declaration of Conformity section	4

### Product Overview

This enabling switch is a device that allows for manually teaching a machine (for example, a robot) to operate while in a hazardous area.

Configure the enabling system so that the machine can operate when the switch is in position 2 (see [Contact Operation \(Press Center of Button\) on page 2](#)).

### Operation Precautions

Do not apply excessive shock to the switch. Wire the switch correctly after reading this publication. To help maintain the safety of the control system, connect each pair of contacts of the three-position switch (terminals 1-2 and 3-4) to a discrepancy detection circuit such as a safety relay module.

Do not wrap the enabling switch with tape, string, wire, rope, elastic bands, and so on, in an attempt to tie down the button to keep the switch in position 2 preventing the original function of the switch from being used as intended. Doing so causes a great risk of danger. If used in wet locations this device must be installed with cables and practices suitable for wet locations.

### Wiring

- To insert a wire into the back of the wire port, push the wire into the terminal.
- To remove the wire, press the pusher, and pull out the wire.

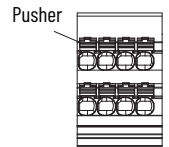

**ATTENTION:**

- After inserting the wiring, pull lightly to make sure that the wire is properly connected.
- When wiring, disconnect the power source.
- Operate the pusher with a force of 20 N (4.5 lbf). Do not press with a force of >40 N (9 lbf).
- Do not pull out the wire without pressing the pusher. When you pull the wire, be sure to pull straight out. Otherwise, the socket can be damaged.
- Cut the wire carefully to get a flat end.
- Make sure that the ferrule sleeve is completely filled by the conductor. Depending on the cross section, the conductor must protrude 0...1 mm (0...0.04 in.) from the ferrule sleeve.

### Applicable Wire Size in Terminal

- Direct wiring  
0.2...1.5 mm<sup>2</sup> (0.005...0.06 in.<sup>2</sup>) X 1 pc  
Wire the enabling switch according to IEC60204-1

**IMPORTANT**

- When using a stranded wire, make sure that the terminals are not short circuited.
- Do not solder the core wires. Use copper wire 60/75 °C (140/167 °F) only (UL 508).
- This device has only been investigated for shock and fire to UL 508.

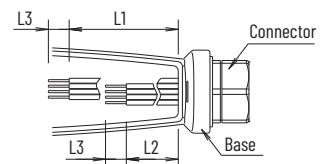
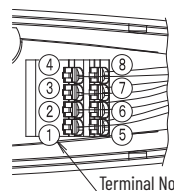

	Terminals 1...4	Terminals 5...8
Wire length	L1 = 35 mm (1.38 in.)	L2 = 30 mm (1.18 in.)
Wire stripping length	L3 = 8...9 mm (0.31...0.35 in.)	

Ferrules

When using stranded wire, insulated ferrule should be used.

- Insulated ferrule: 0.2...0.75 mm<sup>2</sup> (24...18 AWG)
- Crimp Width (a): 1.7 mm (0.07 in.) max
- Height (b): 1.5 mm (0.06 in.) max
- Conductor length (c): 8...9 mm (0.31...0.35 in.)

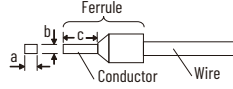

Type	Applicable Wires
S3TL-H025-12WJ	0.25 mm <sup>2</sup> (24 AWG)
S3TL-H034-12WT	0.34 mm <sup>2</sup> (22 AWG)
S3TL-H05-14WA	0.5 mm <sup>2</sup> (20 AWG)
S3TL-H075-14WW	0.75 mm <sup>2</sup> (18 AWG)

Example of Safety Category 4 Wiring Diagram

Figure 1 - Three Position Switch, Manual Reset, Monitored Output

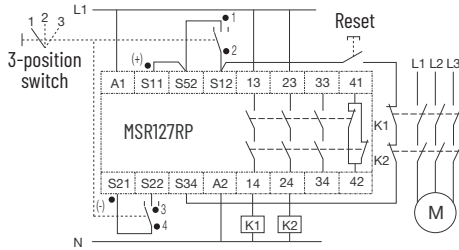

The external wiring is performed according to the protection measures against contact of dangerous potentials, such as double isolation or ground wire connection.

Twin screened and sheathed cable 3-position Enabling Switch

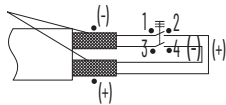

One example of the circuit; Allen-Bradley® Guardmaster® MSR127RP safety relay.

IMPORTANT

Use the monitoring device (safety relay module) providing that it has the capacity to detect a cross-short circuit. Wire channels 1 and 2 of the three-position switch as shown in the diagrams.

Electromechanical switches must be wired with the control unit.

Contact Operation (Press Center of Button)

Figure 2 - Catalog Number 440J-N21TNPM, 440J-N21TNPM-NP

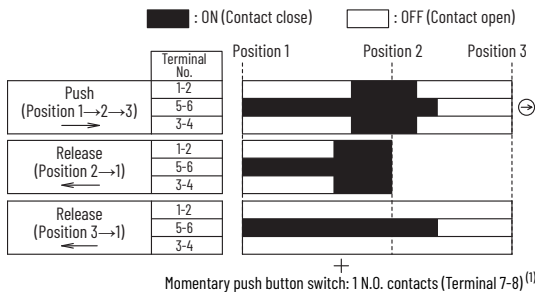

(1) 440J-N21TNPM-NP only.

Figure 3 - Catalog Number 440J-N21TNPM-NE

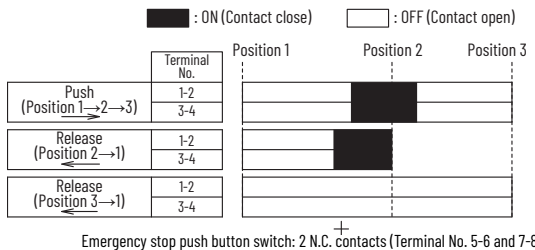

IMPORTANT

- The push monitor switch (terminals 5-6 of 440J-N21TNPM, 440J-N21TNPM-NP) is a positive opening circuit (⊖) when the switch operates from position 2 to 3.
- Use the contacts of terminals 1-2 and 3-4 for the output of the enabling system.
- The characteristics illustrate the performance when the center of the yellow button is pressed. Pressing the edge activates one of the two three-position switches inside earlier than the other, and causes a delay in the operation of the enabling switch.

Specifications

Table 1 - Specifications

Attribute	Value					
Applicable standards	IEC 60947-5-1, EN 60947-5-1, GS-ET-22, JIS C 8201-5-1, UL 508, CSA C22.2 No. 14, IEC 60947-5-8, EN 60947-5-8, GB/T14048.5					
Standards for use	ISO 12100/EN ISO 12100, IEC 60204-1/EN 60204-1, ISO 11616/EN ISO 11616, ISO 10218-1/EN ISO 10218-1, ANSI/RIA/ISO 10218-1, ANSI/RIA R15.06, ANSI B11.19, ISO 13849-1/EN ISO 13849-1					
Certifications	CE Marked for all applicable directives, UKCA Marked for all applicable regulations, cULus Listed, TÜV Certified, CCC Marked					
Contact configuration 3-position switch	Two contacts					
Auxiliary contacts	1 N.C.					
E-stop contacts	2 N.C.					
Push button contact	1 N.O.					
Rated operational voltage (U <sub>e</sub> )	30V    125V    250V					
Rated operating current (I <sub>e</sub> )	3-position switch	AC	Resistive load (AC-12)	—	1 A	0.5 A
			Inductive load (AC-15)	—	0.7 A	0.5 A
		DC	Resistive load (DC-12)	1 A	0.2 A	—
			Inductive load (DC-13)	0.7 A	0.1 A	—
	Auxiliary switch	AC	Resistive load (AC-12)	—	2.5 A	1.5 A
			Inductive load (AC-15)	—	1.5 A	0.75 A
		DC	Resistive load (DC-12)	2.5 A	1.1 A	0.55 A
			Inductive load (DC-13)	2.3 A	0.55 A	0.27 A
	E-stop switch	AC	Resistive load (AC-12)	—	2.5 A	2.5 A
			Inductive load (AC-15)	—	2.5 A	1.5 A
		DC	Resistive load (DC-12)	2 A	0.44 A	0.2 A
			Inductive load (DC-13)	1 A	0.22 A	0.1 A
Push button switch	AC	Resistive load (AC-12)	—	0.5 A	—	
		Inductive load (AC-15)	—	0.3 A	—	
	DC	Resistive load (DC-12)	1 A	0.2 A	—	
		Inductive load (DC-13)	0.7 A	0.1 A	—	
Minimum current	3V, 5 mA AC/DC					
Short-circuit protection device	250V, 10 A fuse (IEC 60127-1)					
Thermal current (I <sub>th</sub> )	2.5 A					
Rated insulation voltage (U <sub>i</sub> )	250V (push button switch: 125V)					
Rated impulse withstand voltage (U <sub>imp</sub> )	2500V (except push button switch)					
Pollution degree	3					
Operating force (dependent on the ambient temperature)	• Position 2: 15 N approximate • Position 3: 50 N maximum					
Actuation frequency, max	1200 operations per hour					

Table 1 - Specifications (Continued)

Attribute	Value
Protection	<ul style="list-style-type: none"> <li>IP66: 440J-N21TNPM</li> <li>IP65: 440J-N21TNPM-NP, 440J-N21TNPM-NE</li> </ul>
Conduit entry	1 x M20 (enclosed within the switch)
Applicable cable diameter	7...13 mm (0.27...0.51 in.)
Insulation resistance, min	100 MΩ
Contact resistance, max	100 Ω
Temperature rise - contact, max	30 °C (86 °F)
Temperature rise - terminal, max	30 °C (86 °F)
Actuator strength, min	500 N
Direct opening force, min	70 N (15.7 lbf) – Push monitor switch
Direct opening travel, min	4.7 mm (0.2 in.) – Push monitor switch
Weight	<ul style="list-style-type: none"> <li>440J-N21TNPM: 195 g (6.88 oz)</li> <li>440J-N21TNPM-NP: 205 g (7.23 oz)</li> <li>440J-N21TNPM-NE: 210 g (7.41 oz)</li> </ul>
Color	Black/gray
Case material of switch body	PA66
Rubber boot material	NBR/PVC
Operating temperature	-10...+60 °C (14...140 °F)
Mechanical life - enabling switch	<ul style="list-style-type: none"> <li>Position 1 - 2 - 1: 1,000,000 operations</li> <li>Position 1 - 2 - 3 - 1: 100,000 operations</li> </ul>
Electrical life	<ul style="list-style-type: none"> <li>Enabling switch: 100,000 operations</li> <li>E-stop: 100,000 operations</li> <li>Push button: 100,000 operations</li> </ul>

**Torque Settings**

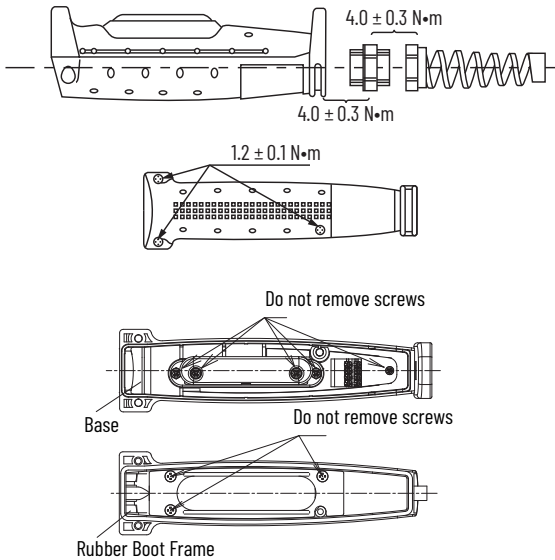

**Repair**

If there is any malfunction or damage, no attempts at repair should be made. The unit should be replaced before machine operation is allowed.

**IMPORTANT** Do not dismantle the unit.

**Approximate Dimensions**

Figure 4 - Enabling Switch [mm (in.)]

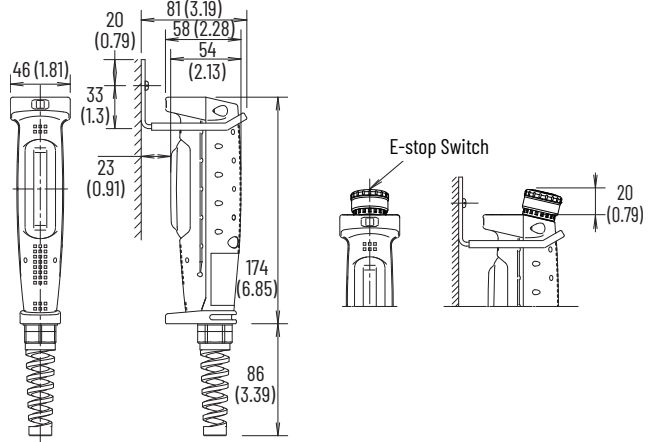

Figure 5 - 440J-AOON Mounting Bracket (Option) [mm (in.)]

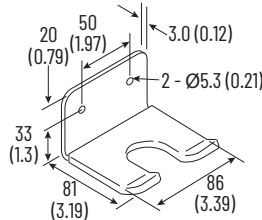
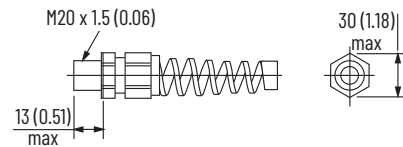

Figure 6 - Connector (One Connector is Included with Enabling Switch) [mm (in.)]



**Maintenance**

Frequency	Description
Every week	<ul style="list-style-type: none"> <li>Check the correct operation of the switching circuit.</li> <li>Check for signs of abuse or tampering.</li> <li>Inspect the switch casing for damage that can cause loss of sealing at the lid or conduit entry.</li> <li>Replace the unit if damage is apparent.</li> </ul>
At least every 6 months	<ol style="list-style-type: none"> <li>Isolate the power.</li> <li>Remove the lid.</li> <li>Inspect all terminals for tightness.</li> <li>Clean out any accumulation of fine dirt.</li> <li>Check for any sign of wear or damage, for example, rubber boot wear or contact oxidization.</li> <li>Replace if wear, damage, or oxidization is apparent.</li> <li>Replace cover and tighten screws to specified settings.</li> <li>Reinstate the power.</li> <li>Check for correct operation.</li> <li>Reapply tamper evident varnish or similar compound to mountings.</li> </ol>

## Declaration of Conformity

### CE Conformity

The Declaration of Conformity declares that the products that are shown in this document conform with Low Voltage Directive (2014/35/EU), Machinery Directive (2006/42/EC), and Restriction of the Use of Certain Hazardous Substances (RoHS) Directive (2011/65/EU and (EU)2015/863).

These products have a third-party approval to the relevant applicable standards EN 60947-5-1 and GS-ET-22 and also conform to the standard EN IEC 63000.

For a comprehensive CE certificate, visit [rok.auto/certifications](http://rok.auto/certifications).

### UKCA Conformity

The Declaration of Conformity declares that the products that are shown in this document conform Electrical Equipment (Safety) Regulation (2016 No. 1101), Supply of Machinery (Safety) Regulations (2008 No. 1597), and Restriction of the Use of Certain Hazardous Substances in Electrical and Electronic Equipment Regulations (2012 No. 3032).

These products have a third-party approval to the relevant applicable standard EN 60947-5-1 and also conform to the standards DIN EN ISO 13849-1 related to GS-ET-22 as the representative and EN IEC 63000.

For a comprehensive UKCA certificate, visit [rok.auto/certifications](http://rok.auto/certifications).

## Additional Resources

To download publications, visit [rok.auto/literature](http://rok.auto/literature) and search for the following publication numbers.

Resource	Description
<a href="#">Industrial Automation Wiring and Grounding Guidelines, publication 1770-4.1</a>	Provides general guidelines for installing a Rockwell Automation industrial system.
<a href="http://rok.auto/certifications">Product Certifications website, rok.auto/certifications</a>	Provides declarations of conformity, certificates, and other certification details.

## Waste Electrical and Electronic Equipment (WEEE)







At the end of life, this equipment should be collected separately from any unsorted municipal waste.

Rockwell Automation maintains current product environmental compliance information on its website at [rok.auto/pec](http://rok.auto/pec).

Your comments help us serve your documentation needs better. If you have any suggestions on how to improve our content, complete the form at [rok.auto/docfeedback](http://rok.auto/docfeedback).

For technical support, visit [rok.auto/support](http://rok.auto/support).

Rockwell Otomasyon Ticaret A.Ş. Kar Plaza İş Merkezi E Blok Kat:6 34752 İçerenköy, İstanbul, Tel: +90 (216) 5698400 EEE Yönetmeliğine Uygundur

Connect with us.    

[rockwellautomation.com](http://rockwellautomation.com)

expanding **human possibility**<sup>®</sup>

AMERICAS: Rockwell Automation, 1201 South Second Street, Milwaukee, WI 53204-2496 USA, Tel: (1) 414.382.2000

EUROPE/MIDDLE EAST/AFRICA: Rockwell Automation NV, Pegasus Park, De Kleetlaan 12a, 1831 Diegem, Belgium, Tel: (32) 2663 0600

ASIA PACIFIC: Rockwell Automation SEA Pte Ltd, 2 Corporation Road, #04-05, Main Lobby, Corporation Place, Singapore 618494, Tel: (65) 6510 6608

UNITED KINGDOM: Rockwell Automation Ltd., Pitfield, Kiln Farm, Milton Keynes, MK11 3DR, United Kingdom, Tel: (44)(1908) 838-800

Allen-Bradley, expanding human possibility, Guardmaster, and Rockwell Automation are trademarks of Rockwell Automation, Inc. Trademarks not belonging to Rockwell Automation are property of their respective companies.

Publication 440J-IN001C-EN-P - December 2025 | Supersedes Publication 440J-IN001B-EN-P - April 2016

Copyright © 2025 Rockwell Automation, Inc. All rights reserved. Printed in the U.S.A.

09279 Ver 05