



# PowerFlex 750-Series Safe Torque Off Option Module

Catalog Numbers 20-750-S, 20-750-S-XT



**Allen-Bradley**

by ROCKWELL AUTOMATION

User Manual

Original Instructions

# Important User Information

Read this document and the documents listed in the additional resources section about installation, configuration, and operation of this equipment before you install, configure, operate, or maintain this product. Users are required to familiarize themselves with installation and wiring instructions in addition to requirements of all applicable codes, laws, and standards.

Activities including installation, adjustments, putting into service, use, assembly, disassembly, and maintenance are required to be carried out by suitably trained personnel in accordance with applicable code of practice.

If this equipment is used in a manner not specified by the manufacturer, the protection provided by the equipment may be impaired.

In no event will Rockwell Automation, Inc. be responsible or liable for indirect or consequential damages resulting from the use or application of this equipment.

The examples and diagrams in this manual are included solely for illustrative purposes. Because of the many variables and requirements associated with any particular installation, Rockwell Automation, Inc. cannot assume responsibility or liability for actual use based on the examples and diagrams.

No patent liability is assumed by Rockwell Automation, Inc. with respect to use of information, circuits, equipment, or software described in this manual.

Reproduction of the contents of this manual, in whole or in part, without written permission of Rockwell Automation, Inc., is prohibited.

Throughout this manual, when necessary, we use notes to make you aware of safety considerations.



**WARNING:** Identifies information about practices or circumstances that can cause an explosion in a hazardous environment, which may lead to personal injury or death, property damage, or economic loss.

---



**ATTENTION:** Identifies information about practices or circumstances that can lead to personal injury or death, property damage, or economic loss. Attentions help you identify a hazard, avoid a hazard, and recognize the consequence.

---

**IMPORTANT**

Identifies information that is critical for successful application and understanding of the product.

---

These labels may also be on or inside the equipment to provide specific precautions.



**SHOCK HAZARD:** Labels may be on or inside the equipment, for example, a drive or motor, to alert people that dangerous voltage may be present.

---



**BURN HAZARD:** Labels may be on or inside the equipment, for example, a drive or motor, to alert people that surfaces may reach dangerous temperatures.

---



**ARC FLASH HAZARD:** Labels may be on or inside the equipment, for example, a motor control center, to alert people to potential Arc Flash. Arc Flash will cause severe injury or death. Wear proper Personal Protective Equipment (PPE). Follow ALL Regulatory requirements for safe work practices and for Personal Protective Equipment (PPE).

---

The following icon may appear in the text of this document.



Identifies information that is useful and can help to make a process easier to do or easier to understand.

	<b>Preface</b>	
	Summary of Changes .....	5
	Conventions.....	5
	Terminology.....	6
	Additional Resources .....	7
	<b>Chapter 1</b>	
<b>Safety Concept</b>	Certification .....	9
	Important Safety Considerations .....	9
	Safety Category 3 Performance Definition .....	10
	Stop Category Definitions .....	10
	Performance Level and Safety Integrity Level (SIL) 3.....	10
	Proof Tests .....	10
	PFDavg and PFH Definitions .....	11
	Safety Data .....	11
	Safe State .....	12
	Safety Reaction Time.....	13
	Considerations for Safety Ratings .....	13
	Contact Information if Safety Option Failure Occurs.....	13
	<b>Chapter 2</b>	
<b>Installation and Wiring</b>	Remove Power to the System .....	16
	Access the Control Pod .....	16
	Set the SAFETY and Hardware ENABLE Jumpers .....	17
	Install the Safety Option Module .....	19
	Wire the Safety Option Module .....	21
	Cabling .....	21
	Power Supply Requirements .....	21
	Verify Operation .....	22
	<b>Chapter 3</b>	
<b>Safe Torque Off Option Module Operation</b>	Operation.....	23
	Stop Category Wiring Examples .....	25
	<b>Appendix A</b>	
<b>Specifications, Certifications, CE Conformity, and UKCA Conformity</b>	Specifications.....	29
	Environmental Specifications.....	30
	Certifications.....	31
	CE Conformity .....	31
	Machinery Directive (2006/42/EC) .....	31
	EMC Directive (2014/30/EU).....	31
	UKCA Conformity.....	32
	UK Supply of Machinery (Safety) Regulation (MD) 2008 No. 1597.....	32
	UK Electromagnetic Compatibility Regulation (EMC) 2016 No. 1091.....	32

<b>History of Changes</b>	<b>Appendix B</b>	
	Change Log .....	33
	<b>Index</b> .....	37

This manual explains how the PowerFlex® 750-Series Safe Torque Off option module can be used in Safety Integrity Level (SIL) 3, Performance Level [PLe], or Category (cat.) 3 applications. It describes the safety requirements, including PFD<sub>avg</sub> and PFH values and application verification information, and provides information on installing, configuring, and troubleshooting the Safe Torque Off option module.

Use this manual if you are responsible for designing, installing, configuring, or troubleshooting safety applications that use the PowerFlex 750-Series Safe Torque Off option modules:

- 20-750-S (standard safety option module version)
- 20-750-S-XT (safety option module version with corrosive gas protection)

The 20-750-S Safe Torque Off option module applies to the following PowerFlex 750-Series drives:

- PowerFlex 755TL low harmonic standalone AC drives
- PowerFlex 755TR regenerative standalone drives
- PowerFlex 755TM drive systems with regenerative bus-supplies and common-bus inverters
- PowerFlex 755TS six-pulse rectifier standalone AC drives
- PowerFlex 755 AC drives
- PowerFlex 753 AC drives

Throughout this manual, **PowerFlex 755T drive products** is used to refer to PowerFlex 755TL drives, PowerFlex 755TR drives, PowerFlex 755TM drive systems and, PowerFlex 755TS drives.

We recommend that you have a basic understanding of the electrical circuitry and familiarity with these products. You must also be trained and experienced in the creation, operation, and maintenance of safety systems.

Rockwell Automation recognizes that some of the terms that are currently used in our industry and in this publication are not in alignment with the movement toward inclusive language in technology. We are proactively collaborating with industry peers to find alternatives to such terms and making changes to our products and content. Please excuse the use of such terms in our content while we implement these changes.

## Summary of Changes

This manual contains new and updated information as indicated in the following table.

Topic	Page
PowerFlex 755TR liquid cooled drive, frame 7L added to Table 2.	11
PowerFlex 755TR liquid cooled drive, frame 7L added to Table 4.	13
PowerFlex 755TR liquid cooled drive, frame 7L added to Stop Category Wiring Examples.	25

## Conventions

In this manual, configuration parameters are product-specific.

Product	Parameter Example
PowerFlex 753/755 AC drives	933 [Start Inhibits]
PowerFlex 755T drive products	10:351 [M Start Inhibits]

## Terminology

This table defines abbreviations that are used in this manual.

Abbreviation	Full Term	Definition
1oo2	One out of Two	Refers to the behavioral design of a dual-channel safety system.
cat.	Category	Classification of the safety-related parts of a control system in respect of their resistance to faults and their subsequent behavior in the fault condition, and which is achieved by the structural arrangement of the parts, fault detection, and/or by their reliability (source EN ISO 13849-1).
CL	Claim Limit	The maximum SIL rating that can be claimed for a Safety-Related Electrical Control System subsystem in relation to architectural constraints and systematic safety integrity (source IEC 62061).
DCavg%	Diagnostic Coverage	Ratio between the failure rate of detected dangerous failures and the failure rate of total dangerous failures. (source IEC 61508).
EN	European Norm	The official European Standard.
ESD	Emergency Shutdown Systems	A system, usually independent of the main control system, that is designed to shut down an operating system safely.
HFT	Hardware Fault Tolerance	The HFT equals $n$ , where $n+1$ faults could cause the loss of the safety function. An HFT of 1 means that 2 faults are required before safety is lost.
HIM	Human Interface Module	A module used to configure a device.
IEC	International Electrotechnical Commission	The International Electrotechnical Commission (IEC) is the world's leading organization that prepares and publishes International Standards for all electrical, electronic, and related technologies.
IGBT	Insulated Gate Bi-polar Transistors	Typical power switch used to control main current.
ISO	International Organization for Standardization	The International Organization for Standardization is an international standard-setting body that is composed of representatives from various national standards organizations.
MTTF <sub>D</sub>	Mean Time to Failure	The average length of time before a device has a dangerous failure.
PELV	Protective Extra Low Voltage	An electrical system where the voltage cannot exceed ELV under normal conditions, and under single-fault conditions, except earth faults in other circuits. PELV is defined in IEC 61131-2.
PFD <sub>avg</sub>	Probability of a dangerous failure on demand	The average probability of a system to fail to perform its design function on demand.
PFH	Average Frequency of a Dangerous Failure per Hour	The average frequency of a system to have a dangerous failure occur per hour.
PL	Performance Level	EN ISO 13849-1 safety rating.
SELV	Safety Extra Low Voltage Circuit	A secondary circuit that is designed and protected so that, under normal and single fault conditions, its voltages do not exceed a safe value. SELV is defined in IEC 61010-2-201.
SIL	Safety Integrity Level	A measure of a products ability to lower the risk that a dangerous failure could occur.
STO	Safe Torque Off	The Safe Torque Off (STO) function is used to prevent unexpected motor rotation if there is an emergency while the drive remains connected to the power supply. When STO is activated, the torque power cannot reach the drive, thus stopping and preventing any motor shaft rotation.
UKCA	UK Conformity Assessment	Certification mark that indicates conformity with the applicable requirements for products sold within Great Britain.

## Additional Resources

These documents contain additional information concerning related Rockwell Automation products. You can view or download publications at [rok.auto/literature](http://rok.auto/literature).

Resource	Description
PowerFlex Safe Speed Monitor Safety Reference Manual, publication <a href="#">750-RM001</a>	Provides information on installing and configuring the safe speed monitor option module with PowerFlex 750-Series drives.
System Design for Control of Electrical Noise Reference Manual, publication <a href="#">6MC-RM001</a>	Information, examples, and techniques that are designed to minimize system failures caused by electrical noise.
Safety Guidelines for the Application, Installation, and Maintenance of Solid State Control, publication <a href="#">SGI-11</a>	Describes important differences between solid-state control and hardwired electromechanical devices.
Enhanced PowerFlex 7-Class Human Interface Module (HIM) User Manual, publication <a href="#">20HIM-UM001</a>	Provides information for using the 20-HIM-A6 Human Interface Module to configure PowerFlex 750-Series drives and the Safe Torque Off option module.
Connected Components Workbench Online Help	Online Help that provides a description of the different elements of the Connected Components Workbench™ software.
PowerFlex 750-Series Products with TotalFORCE® Control Technical Data, publication <a href="#">750-TD100</a>	Provides detailed information on: <ul style="list-style-type: none"> <li>• Drive and bus supply specifications</li> <li>• Option specifications</li> <li>• Fuse and circuit breaker ratings</li> </ul>
PowerFlex 750-Series Products with TotalFORCE Control Installation Instructions, publication <a href="#">750-IN100</a>	Provides the basic steps to install PowerFlex 755TL drives, PowerFlex 755TR drives, and PowerFlex 755TM bus supplies.
PowerFlex 755TM IP00 Open Type Kits Installation Instructions, publication <a href="#">750-IN101</a>	Provides instructions to install IP00 Open Type kits in user-supplied enclosures.
PowerFlex 755TS Products with TotalFORCE Control Installation Instructions, publication <a href="#">750-IN119</a>	Provides the basic steps to install PowerFlex 755TS drives.
PowerFlex 755TS Products with TotalFORCE Control Technical Data, publication <a href="#">750-TD104</a>	Provides detailed information on: <ul style="list-style-type: none"> <li>• Drive specifications</li> <li>• Option specifications</li> <li>• Fuse and circuit breaker ratings</li> </ul>
PowerFlex TotalFORCE Firmware Revisions 10.xxx and Later Documentation Set: <ul style="list-style-type: none"> <li>• PowerFlex Drives with TotalFORCE Control Programming Manual, publication <a href="#">750-PM101</a></li> <li>• PowerFlex Drives with TotalFORCE Control Parameters Reference Data, publication <a href="#">750-RD101</a></li> <li>• PowerFlex Drives with TotalFORCE Control Conditions Reference Data, publication <a href="#">750-RD102</a></li> </ul>	Provides detailed information on: <ul style="list-style-type: none"> <li>• Startup, control algorithms, and status indicators</li> <li>• Parameters and programming</li> <li>• Faults, alarms, events, and troubleshooting</li> </ul>
PowerFlex Drives with TotalFORCE Control Programming Manual Firmware Revisions 6.xxx and Earlier, publication <a href="#">750-PM100</a>	Provides detailed information on: <ul style="list-style-type: none"> <li>• I/O, control, and feedback options</li> <li>• Parameters and programming</li> <li>• Faults, alarms, and troubleshooting</li> </ul>
PowerFlex 755TM IP00 Open Type Kits Technical Data, publication <a href="#">750-TD101</a>	Provides detailed information on: <ul style="list-style-type: none"> <li>• Kit selection</li> <li>• Kit ratings and specifications</li> <li>• Option specifications</li> </ul>
PowerFlex 750-Series AC Drives Technical Data, publication <a href="#">750-TD001</a>	Provides detailed information on: <ul style="list-style-type: none"> <li>• Packaged drive specifications</li> <li>• Option specifications</li> <li>• Fuse and circuit breaker ratings</li> </ul>
PowerFlex 750-Series AC Drive Installation Instructions, publication <a href="#">750-IN001</a>	Provides information on installing the Safe Torque Off option module in PowerFlex 750-Series drive.
PowerFlex 750-Series AC Drives Programming Manual, publication <a href="#">750-PM001</a>	Provides information on mounting, installing, and configuring PowerFlex 750-Series drives.
Product Certifications website, <a href="http://rok.auto/certifications">rok.auto/certifications</a>	Provides declarations of conformity, certificates, and other certification details.

**Notes:**

## Safety Concept

This chapter describes the safety Performance Level concept and how the PowerFlex® 750-Series Safe Torque Off option module meets the requirements for SIL 3, or cat. 3, PLe applications.

Topic	Page
Certification	9
Proof Tests	10
PFDavg and PFH Definitions	11
Safety Data	11
Safe State	12
Safety Reaction Time	13
Considerations for Safety Ratings	13
Contact Information if Safety Option Failure Occurs	13

## Certification

The PowerFlex 750-Series Safe Torque Off option module is certified for use in safety applications up to and including SIL 3 according to EN/IEC 61800-5-2, IEC 61508, and SIL CL3 according to EN 62061, Performance Level PLe, and Category 3 according to EN ISO 13849-1. Safety requirements are based on the standards current at the time of certification.

The TÜV Rheinland group has approved the PowerFlex 750-Series Safe Torque Off option module for use in safety-related applications where the de-energized state is considered to be the safe state. The examples in this manual are based on achieving de-energization as the safe state for typical Machine Safety and Emergency Shutdown (ESD) systems.

## Important Safety Considerations

The system user is responsible for the following:

- Set-up, safety rating, and validation of any sensors or actuators connected to the system
- Complete system-level risk assessment and reassess the system any time a change is made
- Certification of the system to the desired safety Performance Level
- Project management and proof testing
- Program the application software and the safety option module configurations in accordance with the information in this manual
- Access control to the system
- Analyze all configuration settings and choose the proper setting to achieve the required safety rating

---

**IMPORTANT** When applying Safety, restrict access to qualified, authorized personnel who are trained and experienced.

---



**ATTENTION:** When designing your system, consider how personnel exit the machine if the door locks while they are in the machine. Additional safeguarding devices may be required for your specific application.

## Safety Category 3 Performance Definition

To achieve Safety Category 3, according to EN ISO 13849-1, design the safety-related parts according to these guidelines:

- The safety-related parts of machine control systems and/or their protective equipment, and their components, shall be designed, constructed, selected, assembled, and combined in accordance with relevant standards so that they can withstand expected conditions
- Basic safety principles shall be applied
- A single fault in any of its parts does not lead to a loss of safety function.
- The average diagnostic coverage of the safety-related parts of the control system shall be medium
- The mean-time to dangerous failure of each of the redundant channels shall be high
- Measures against common cause failure shall be applied

## Stop Category Definitions

Conduct a risk assessment to determine the selection of a stop category for each stop function.

- Stop Category 0 is achieved with immediate removal of power to the actuator. This results in an uncontrolled coast-to-stop. Safe Torque Off accomplishes a Stop Category 0 stop.
- Stop Category 1 is achieved with power available to the machine actuators to achieve the stop. Power is removed from the actuators when the stop is achieved.

**IMPORTANT** When designing the machine application, consider timing and distance for a coast-to-stop (Stop Category 0 or Safe Torque Off). For more information regarding stop categories and Safe Torque Off, see EN 60204-1 and EN/IEC 61800-5-2, respectively.

## Performance Level and Safety Integrity Level (SIL) 3

For safety-related control systems, Performance Level (PL), according to EN ISO 13849-1, and SIL levels, according to IEC 61508 and EN 62061, include a rating of the ability of the system to perform its safety functions. All safety-related components of the control system must be included in both a risk assessment and the determination of the achieved levels.

See the EN ISO 13849-1, IEC 61508, and EN 62061 standards for complete information on requirements for PL and SIL determination.

## Proof Tests

The safety standards require that proof tests be performed on the equipment that is used in the system. Proof tests are performed at user-defined intervals and are dependent upon  $PFD_{avg}$  and PFH values.

**IMPORTANT** Your specific application determines the time frame for the proof test interval.  
Verify operation of safety function after drive installation, modification, or maintenance. See [Verify Operation](#) on [page 22](#) for more information.

## PFD<sub>avg</sub> and PFH Definitions

Safety-related systems can be classified as operating in either a Low Demand mode, or in a High Demand/Continuous mode.

- Low Demand mode: where the frequency of demands for operation that are made on a safety-related system is no greater than one per year or no greater than twice the proof test frequency.
- High Demand/Continuous mode: where the frequency of demands for operation that are made on a safety-related system is greater than once per year or greater than twice the proof test interval.

The SIL value for a low-demand safety-related system is directly related to order-of-magnitude ranges of its average probability of failure to perform its safety function satisfactorily on demand or, simply, average probability of a dangerous failure on demand (PFD<sub>avg</sub>). The SIL value for a High Demand/continuous mode safety-related system is directly related to the average frequency of a dangerous failure occurring per hour (PFH).

## Safety Data

PFD<sub>avg</sub> and PFH calculations are based on the equations from Part 6 of IEC 61508.

These tables provide data for a 20-year proof test interval and demonstrate the worst-case effect of various configuration changes on the data.

**IMPORTANT** Determination of safety parameters is based on the assumptions that the system operates in High-demand mode and that the safety function is requested at least once every year.

Table 1 - PFD<sub>avg</sub> and PFH for PowerFlex 753 and PowerFlex 755 Drives

Attribute	PowerFlex 753 and PowerFlex 755 Frames 1...7	PowerFlex 755 Frame 8	PowerFlex 755 Frame 9	PowerFlex 755 Frame 10
PFD <sub>avg</sub>	3.29E-5	1.73E-4	2.65E-4	3.56E-4
PFH (1/hour)	3.75E-10	1.99E-9	3.04E-9	4.09E-9
SIL	3	3	3	3
PL	e	e	e	e
Category	3	3	3	3
MTTF <sub>D</sub> years	143	171.9	104.4	75.5
DC <sub>avg</sub> %	99 (high)	97.4 (high)	97.5 (high)	97.5 (high)
HFT	1(1002)	1(1002)	1(1002)	1(1002)
Mission time	20 years	20 years	20 years	20 years

Table 2 - PFD<sub>avg</sub> and PFH for PowerFlex 755T Drive Products

Attribute	Frames 5, 6, and 6L	Frames 7, 7L, and 8	Frame 9	Frame 10	Frame 11	Frame 12	Frame 13	Frame 14	Frame 15
PFD <sub>avg</sub>	3.70E-5	2.48E-4	2.74E-4	3.00E-4	3.26E-4	3.52E-4	3.77 E-4	4.29 E-4	4.81 E-4
PFH (1/hour)	4.22E-10	2.86E-9	3.15E-9	3.45E-9	3.75E-9	4.05E-9	4.34 E-9	4.94 E-9	5.54 E-9
SIL	3	3	3	3	3	3	3	3	3
PL	e	e	e	e	e	e	e	e	e
Category	3	3	3	3	3	3	3	3	3
MTTF <sub>D</sub> years	1055.5 (high)	186.7 (high)	142.7 (high)	115.5 (high)	97.0 (high)	83.7 (high)	73.5 (high)	59.2 (high)	49.5 (high)
DC <sub>avg</sub> %	94.8 (high)	96.3 (high)	96.4 (high)	96.6 (high)	96.6 (high)	96.6 (high)	96.7 (high)	96.7 (high)	96.7 (high)
HFT	1(1002)	1(1002)	1(1002)	1(1002)	1(1002)	1(1002)	1(1002)	1(1002)	1(1002)
Mission time	20 years	20 years	20 years	20 years	20 years	20 years	20 years	20 years	20 years

**Table 3 - PFD<sub>avg</sub> and PFH for PowerFlex 755TS Drives**

Attribute	Frames 1...7, and 7A
PFD <sub>avg</sub>	3.33E-05
PFH (1/hour)	3.79E-10
SIL	3
PL	e
Category	3
MTTF <sub>D</sub> years	1792.3
DC <sub>avg</sub> %	94.5 (high)
HFT	1(1002)
Mission time	20 years

## Safe State

The safe state encompasses all operation that occurs outside of the other monitoring and stopping behavior that is defined as part of the Safe Torque Off option module.

If a Safe State fault is detected, the safety option module transitions to the safe state. This includes faults that are related to the integrity of hardware or firmware. The drive safe state is defined as preventing force-producing power from being provided to the motor. For more information on the safe state, see EN/IEC 61800-5-2.

---

**IMPORTANT** The drive is in the safe state if the safety function is installed and the drive status is 'Not Enabled'. Drive 'Ready' is NOT a safe state even if there is no motion.

---



**ATTENTION:** In circumstances where external influences (for example, falling of suspended loads) are present, additional measures (for example, mechanical brakes) can be necessary to help prevent a hazard.

---

## Safety Reaction Time

The safety reaction time is the length of time from a safety-related event as input to the system until the system is in the safe state.

The safety reaction time from an input signal condition that triggers a safe stop, to the initiation of the configured Stop Type, is shown in [Table 4](#).

**Table 4 - Safety Reaction Time**

Drive Family	Value, Max
PowerFlex 753 drives Frames 1...7	10 ms
PowerFlex 755 drives Frames 1...10	
PowerFlex 755TL drives, PowerFlex 755TR drives, PowerFlex 755TM drive systems Frames 7...15	
PowerFlex 755TR drives Frame 7L	
PowerFlex 755TS drives Frames 1...7, and 7A	
PowerFlex 755TL drives, Frames 5 and 6	20 ms
PowerFlex 755TR drives Frames 5, 6, and 6L	

**IMPORTANT** An input signal condition that is present for less than the reaction time cannot result in the safety function being performed. Repeated requests of the safety function for less than the reaction time can result in a spurious detection of a fault.

**Figure 1 - Safety Reaction Timing Diagram**

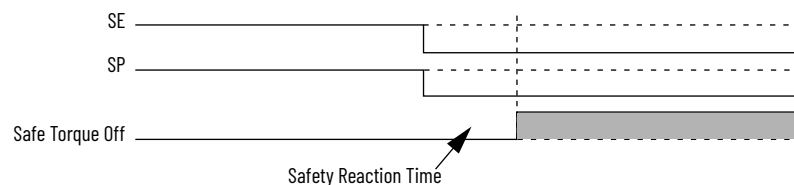

## Considerations for Safety Ratings

The achievable safety rating of an application using the safety option module installed in PowerFlex 750-Series drives is dependent upon many factors, drive options, and the type of motor.

For applications that rely on the immediate removal of power to the actuator, which results in an uncontrolled coast-to-stop, a safety rating up to and including SIL 3, PLe, and Category 3 can be achieved.

## Contact Information if Safety Option Failure Occurs

If you experience a failure with any safety-certified device, contact your local Rockwell Automation sales office or Allen-Bradley® distributor. With this contact, you can do the following:

- Return the device to Rockwell Automation so the failure is appropriately logged for the catalog number that is affected and a record is made of the failure.
- Request a failure analysis (if necessary) to determine the probable cause of the failure.

**Notes:**

## Installation and Wiring

This chapter provides installation, jumper settings, and wiring for the PowerFlex® 750-Series Safe Torque Off option module.

Topic	Page
Remove Power to the System	16
Access the Control Pod	16
Set the SAFETY and Hardware ENABLE Jumpers	17
Install the Safety Option Module	19
Wire the Safety Option Module	21
Verify Operation	22



**ATTENTION:** The following information is merely a guide for proper installation. Rockwell Automation cannot assume responsibility for the compliance or the noncompliance to any code, national, local, or otherwise for the proper installation of this equipment. A hazard of personal injury and/or equipment damage exists if codes are ignored during installation.

**IMPORTANT** Installation must be in accordance with the instructions in this user manual and the installation instructions for your drive. Only qualified, authorized personnel that are trained and experienced in safety can plan, implement, and apply safety systems.

**IMPORTANT** During installation and maintenance, check your drive firmware release notes for known anomalies and verify that there are no safety-related anomalies.

The PowerFlex 750-Series Safe Torque Off option module is intended to be part of the safety-related control system. Before installation, perform a risk assessment that compares the PowerFlex 750-Series Safe Torque Off option module specifications and all foreseeable operational and environmental characteristics of the control system.

A safety analysis of the machine section that is controlled by the drive is required to determine how often to test the safety function for proper operation during the life of the machine.

## Remove Power to the System

Before performing any work on this drive, remove all power to the system.



### ATTENTION:

- Electrical Shock Hazard. Verify that all sources of AC and DC power are de-energized and locked out or tagged out in accordance with the requirements of ANSI/NFPA 70E, Part II.
- To avoid an electric shock hazard, verify that the voltage on the bus capacitors has discharged before performing any work on the drive. Measure the DC bus voltage at the +DC and -DC terminals or test points. The voltage must be zero.

For the location of the terminal block and test point sockets, see the manual for your drive:

- PowerFlex 750-Series AC Drives Installation Instructions, publication [750-IN001](#).
- PowerFlex 750-Series Products with TotalFORCE Control Installation Instructions, publication [750-IN100](#).
- PowerFlex 755TM IPO0 Open Type Kits Installation Instructions, publication [750-IN101](#).
- PowerFlex 750TS Products with TotalFORCE Control Installation Instructions, publication [750-IN119](#).
- In Safe Torque Off mode, hazardous voltages may still be present at the motor. To avoid an electric shock hazard, disconnect power to the motor and verify that the voltage is zero before performing any work on the motor.

## Access the Control Pod

The option module is installed in the drive control pod. Different drives have different ways to access the control pod.

To access the control pod, follow these steps.

1. Open the door or remove cover.
2. Loosen the retention screw on the HIM cradle.
3. Lift the cradle until the latch engages.

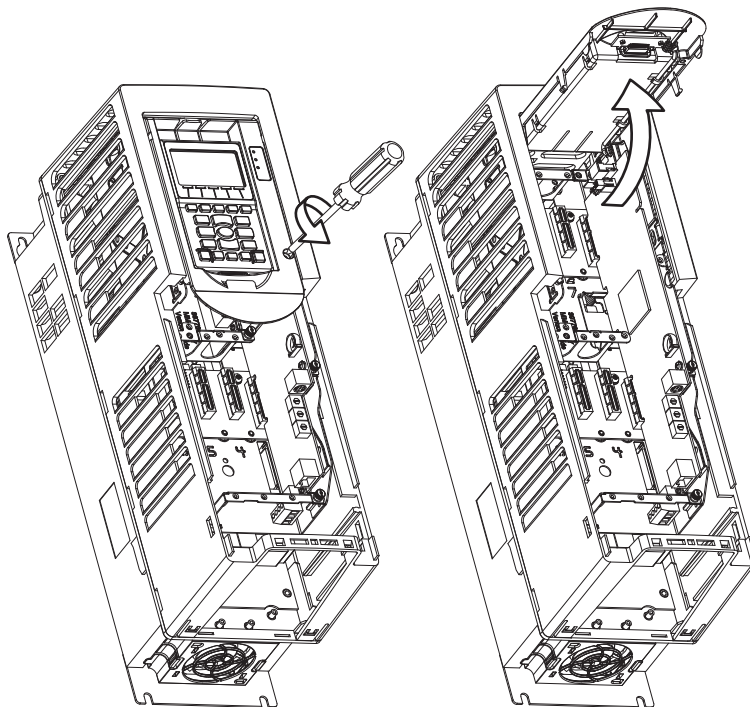

Panel-mounted Drives

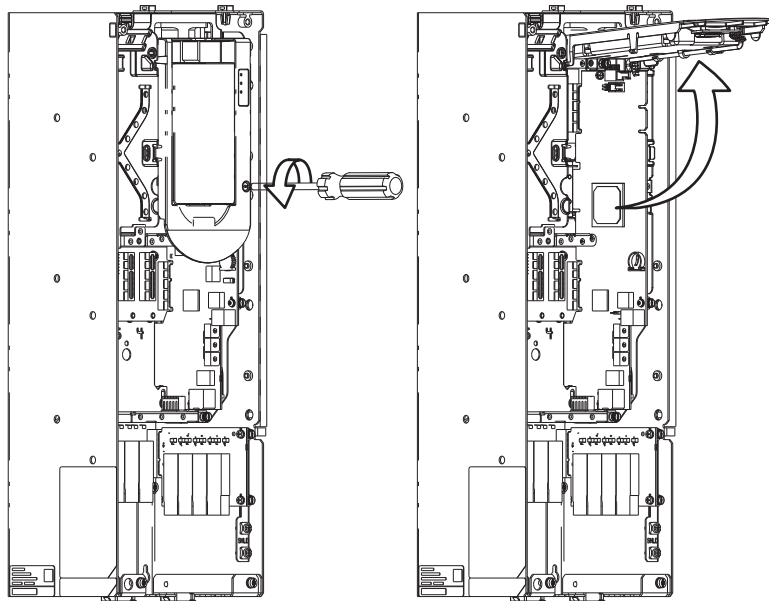

Drives in Cabinet Enclosures

See the installation instructions for your drive for more information.

## Set the SAFETY and Hardware ENABLE Jumpers

The drive ships with the SAFETY enable jumper and the hardware ENABLE jumper installed. Both of these jumpers are on the main control board.

---

**IMPORTANT** PowerFlex 755 drives (frames 8...10) control boards do not have a SAFETY enable jumper.

---

To configure the product to use the PowerFlex 750-Series Safe Torque Off option module, complete the following steps.

1. Access the control pod.
2. Locate and remove the SAFETY enable jumper on the main control board.  
If the SAFETY enable jumper is installed when using a safety option the drive will fault.
3. Locate and make sure that the hardware ENABLE jumper is installed.

**Figure 2 - PowerFlex 753 Drives Jumper Locations**

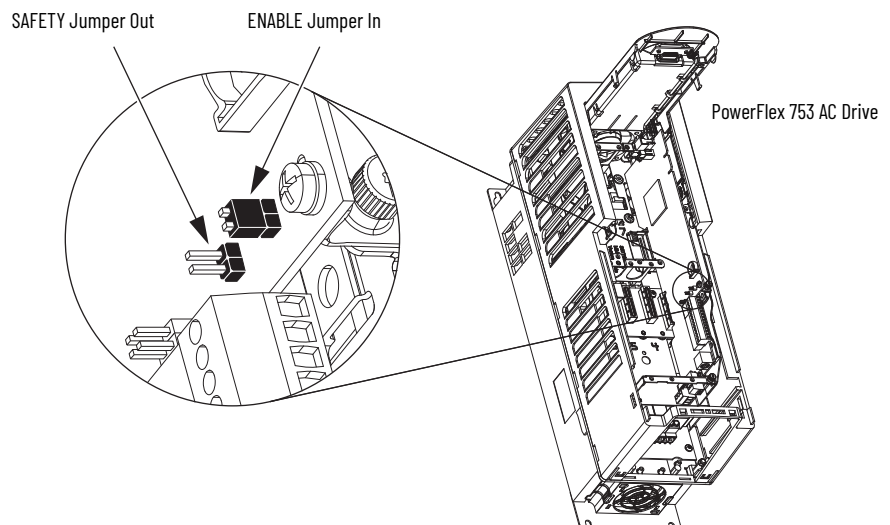

Figure 3 - PowerFlex 755 Drives Jumper Locations (Frames 1...7 only)

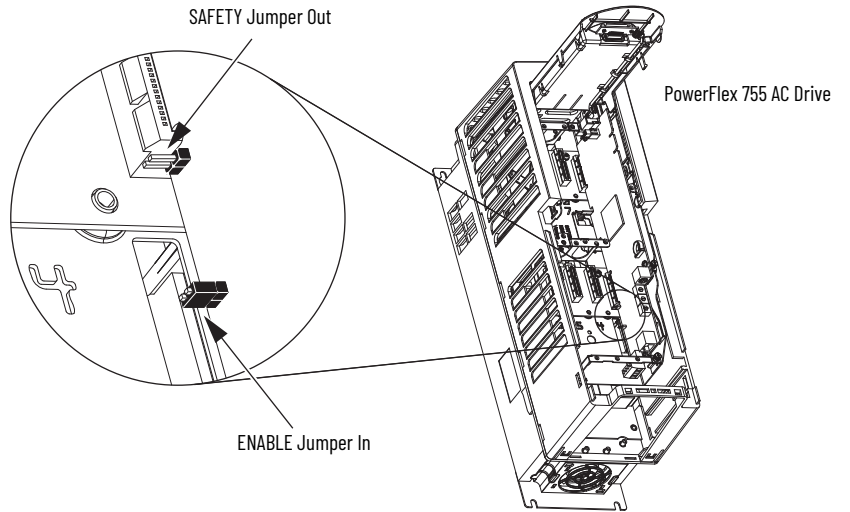

Figure 4 - PowerFlex 755T Products Jumper Locations

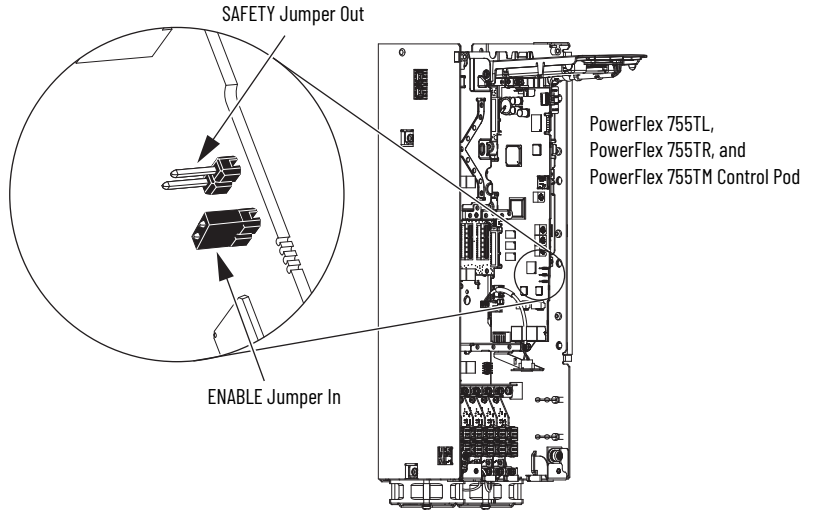
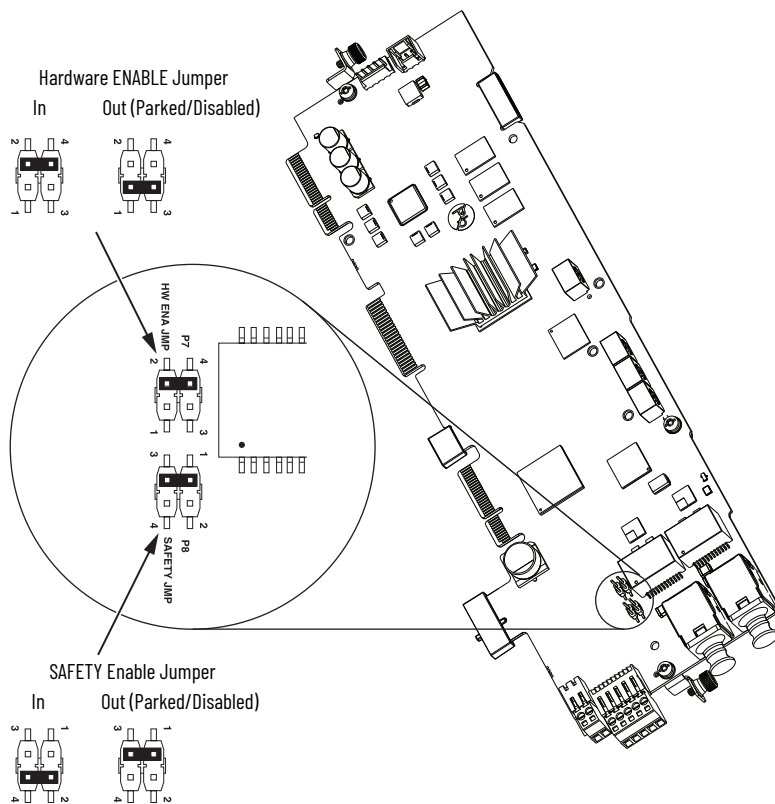

Figure 5 - PowerFlex 755TS Drives Jumper Locations



## Install the Safety Option Module

To install the Safe Torque Off option module:

1. Firmly press the module edge connector into the desired port.

---

**IMPORTANT** The Safe Torque Off option module can be installed in any drive port. However, when used in an integrated motion application, the module must be installed in port 6.

---



---

**IMPORTANT** Only one safety option module can be installed at a time. Installing multiple or duplicate safety option modules is not supported.

---

2. Tighten the top and bottom retaining screws.
  - Recommended torque = 0.45 N•m (4.0 lb•in)
  - Recommended screwdriver = T15 Hexalobular





---

**IMPORTANT** Do not overtighten retaining screws.

---

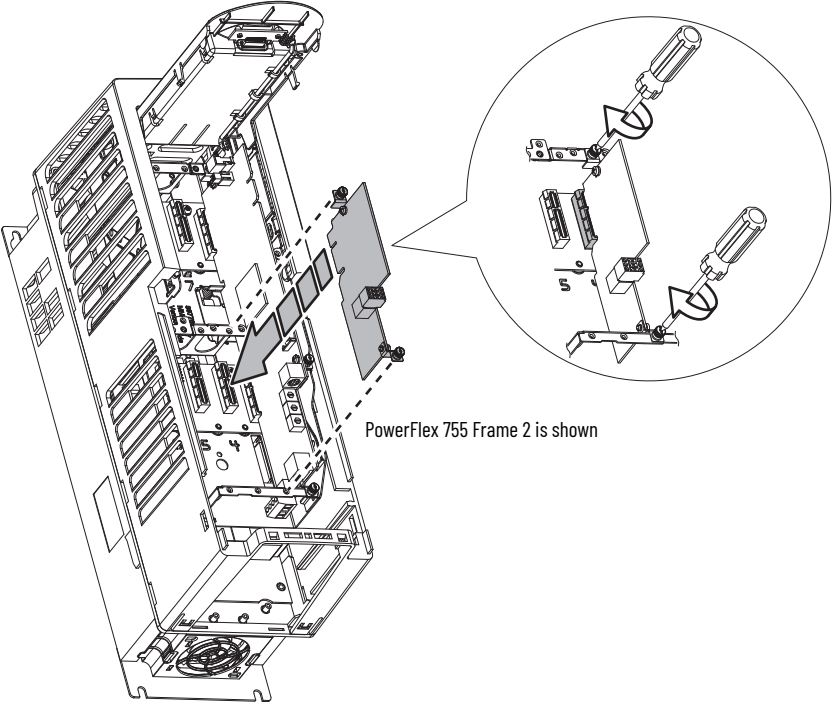
Figure 6 - Install Safety Option Module



## Wire the Safety Option Module

Observe these wiring guidelines when installing the safety option module:

- Use copper wire with an insulation rating of 600V or greater is recommended.
- Separate control wires from power wires by at least 0.3 m (1 ft).

**Table 5 - Safety Option Module Terminal Block Specifications**

Wire Size Range		Wire Type	Strip Length
Maximum	Minimum		
0.8 mm <sup>2</sup> (18 AWG)	0.3 mm <sup>2</sup> (28 AWG)	Multi-conductor shielded cable	10 mm (0.39 in.)

**Table 6 - TB2 Terminal Designations**

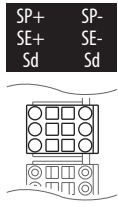
	Terminal	Name	Description
	SP+	+24 Volt Safety Power	User-supplied power: 24 volt ±10% 45 mA typical
	SP-	Safety Power Common	
	SE+	+24 Volt Safety Enable	User-supplied power: 24 volt ±10% 25 mA typical
	SE-	Safety Enable Common	
	Sd	Shield	Terminating point for wiring shields when an EMC plate or conduit box is not installed.
	Sd	Shield	

Safe Torque Off Option Modules  
20-750-S and 20-750-S-XT

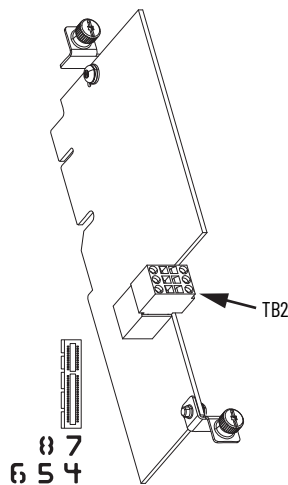

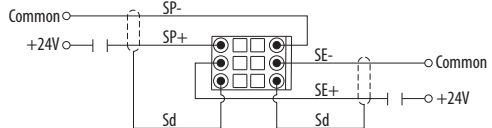
Safety Input	Connection Example
Dedicated Power Supply	

## Cabling

Safety input wiring must be protected against external damage by cable ducting, conduit, armored cable, or other means.

Shielded cable is required. For proper shield termination, follow the installation requirements that are related to EN 61800-3 and the EMC Directive as described in these publications:

- PowerFlex 750-Series AC Drive Installation Instructions, publication [750-IN001](#).
- PowerFlex 750-Series Products with TotalFORCE Control Installation Instructions, publication [750-IN100](#).
- PowerFlex 750TS Products with TotalFORCE Control Installation Instructions, publication [750-IN119](#).

## Power Supply Requirements

The external power supply must conform to the Directive 2014/35/EU Low Voltage, by applying the requirements of EN61131-2 Programmable Controllers, Part 2 - Equipment Requirements and Tests and one of the following:

- EN60950 - SELV (Safety Extra Low Voltage)
- EN60204 - PELV (Protective Extra Low Voltage)
- IEC 60536 Safety Class III (SELV or PELV)
- UL 508 Limited Voltage Circuit
- 24V DC ±10% must be supplied by a power supply that complies with IEC 60204 and IEC 61558-1.

For specific power supply recommendations, refer to your drive installation instructions:

- PowerFlex 750-Series Products with TotalFORCE Control Installation Instructions, publication [750-IN100](#).
- PowerFlex 750-Series AC Drives Installation Instructions, publication [750-IN001](#).
- PowerFlex 750TS Products with TotalFORCE Control Installation Instructions, publication [750-IN119](#).

For planning information, see the guidelines in Industrial Automation Wiring and Grounding Guidelines, publication [1770-4.1](#).

## Verify Operation

Test the safety function for proper operation after initial installation of the safety option module. Retest the safety function at the intervals that are determined by the safety analysis that is described on [page 15](#).

Verify that both safety channels are functioning according to [Table 7](#).

**Table 7 - Channel Operation and Verification**

Safety Function Status	Drive Not Enabled	Drive Not Enabled	Drive Not Enabled	Drive Enabled (Ready)
<b>Safety Channel Operation</b>				
<b>Safety Option Module Terminals</b> SP+ & SP- (safety power)	No Power Applied	Power Applied	No Power Applied	Power Applied
<b>Safety Option Module Terminals</b> SE+ & SE- (safety enable)	No Power Applied	No Power Applied	Power Applied	Power Applied

**IMPORTANT**

If an external fault is present on the wiring or circuitry controlling the Safety Enable or Safety Power inputs for a period of time, the safety option module does not detect this condition. When the external fault condition is removed, the safety option module allows an enable condition.

To achieve maximum safety rating, both safety inputs SP and SE must be activated by appropriate dual-channel equipment. The repeated activation of the safety function by only one input at a time can result in a spurious detection of a fault.



There is no safe-status output provided on the safety option module.

## Safe Torque Off Option Module Operation

This chapter provides operation and Stop Category example wiring diagrams for the PowerFlex® 750-Series Safe Torque Off option module.

Topic	Page
Operation	23
Stop Category Wiring Examples	25

### Operation

The PowerFlex 750-Series Safe Torque Off option module (see [Figure 7](#)) disables the drive's output IGBTs by disconnecting power to the gate control driver IC, or disabling the output of the gate-control driver IC. This helps prevent the drive's output power devices from switching in the pattern necessary to generate AC power to the motor.

The safety option module can be used in combination with other safety devices to satisfy the requirements of IEC 61508, EN/IEC 61800-5-2 SIL 3, EN ISO 13849-1 PLe, and Category 3 for Safe Torque Off (STO).

---

**IMPORTANT** The safety option module is suitable for performing mechanical work on the drive system or affected area of a machine only. It does not provide electrical safety.  
Do not use the safety option module as a control for starting and/or stopping the drive.

---



---

**IMPORTANT** The safety option module does not eliminate dangerous voltages at the drive output. Input power to the drive must be turned off and safety procedures followed before performing any electrical work on the drive or motor. See [Remove Power to the System](#) on [page 16](#) for more information.

---



**ATTENTION:** In the event of the failure of two output IGBTs in the drive, when the safety option module has controlled the drive outputs to the OFF state, the drive can provide energy for up to 180° of rotation in a 2-pole motor before torque production in the motor ceases.

---

Under normal operation, 24V DC is applied to both the Safety Power and Safety Enable inputs of the safety option module. If the Safety Enable or Safety Power is de-energized, the outputs of the gate-control driver IC are disabled and IGBT firing is disabled. For PowerFlex 753/755 drives, parameter 933 [Start Inhibits] indicates that IGBTs are inhibited and the HIM indicates that the drive is not enabled. For PowerFlex 755T drive products, this is indicated in parameter 10:351 [M Start Inhibits].

---



**ATTENTION:** By itself, the safety option module initiates a coast-to-stop action. Additional protective measures must be applied when an application requires a different stopping action.

---

Figure 7 - Drive Safe Torque Off Circuitry

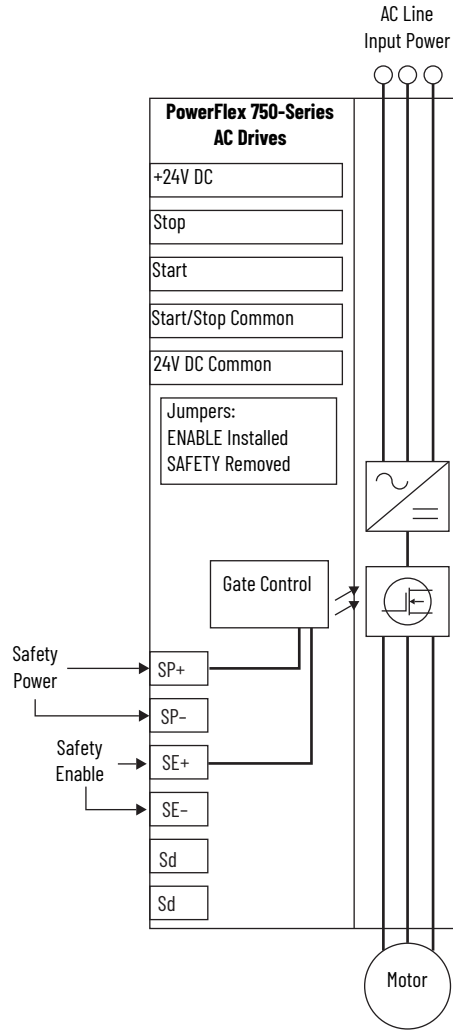

# Stop Category Wiring Examples

The following diagrams illustrate Stop Category 0 and Stop Category 1 dual-channel wiring examples for PowerFlex 750-Series drives with Guardmaster® safety relays. Examples include the following drive families:

- PowerFlex 753 and PowerFlex 755 Drives, Frames 1...10
- PowerFlex 755T Products, Frames 5, 6, 6L, 7, 7L, and 8...15
- PowerFlex 755TS Drives, Frames 1...7, and 7A

Figure 8 - Stop Category 0

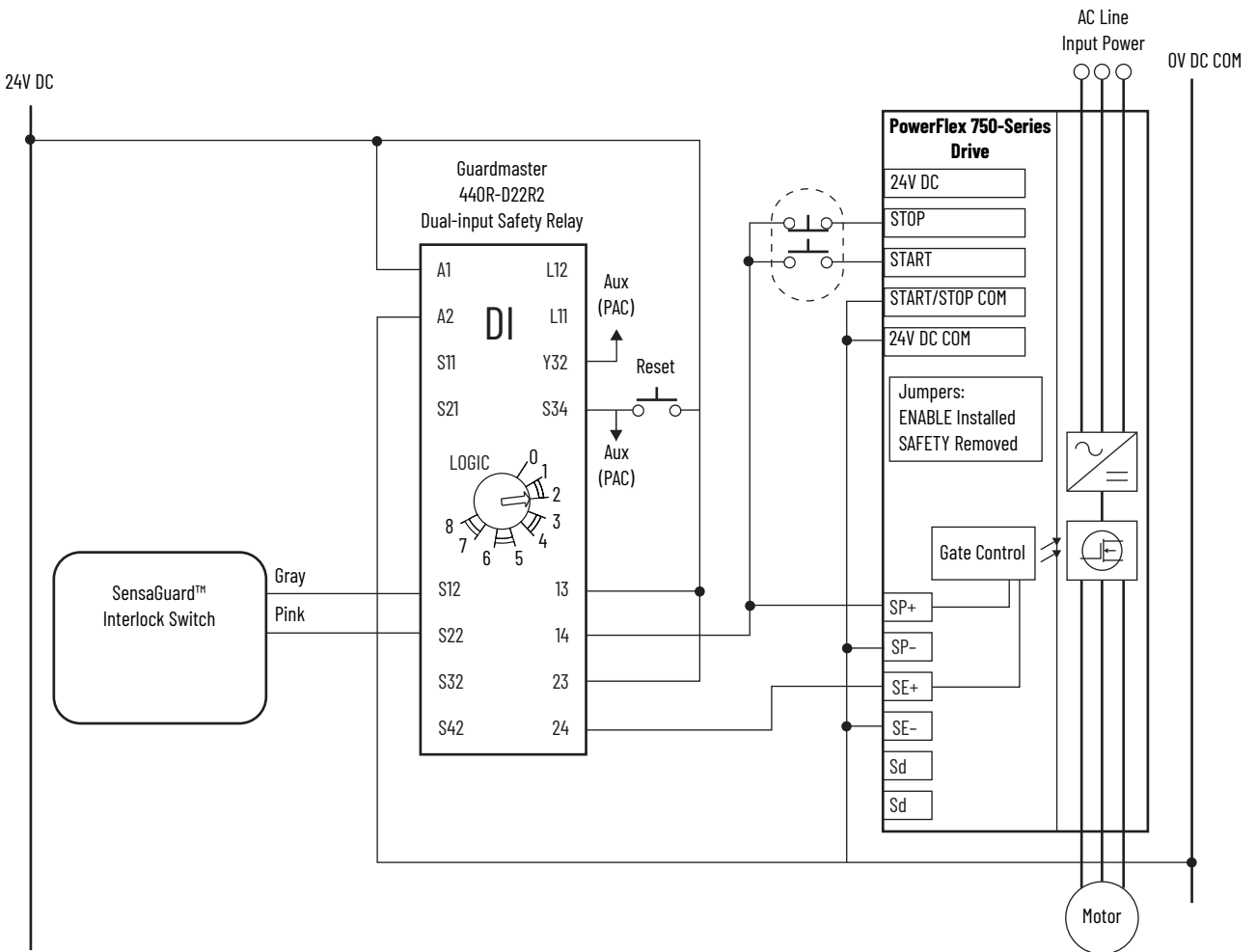

Table 8 - Guardmaster DI Example Summary

Attribute	Description
Circuit status	Circuit is shown with guard door closed and system ready for normal drive operation.
Operating principle	This is a dual-channel system with monitoring of the Safe Torque Off circuit and drive. Opening the guard door switches the input circuits (S12 and S22) to the Guardmaster monitoring safety relay. The output circuits (13, 14 and 23, 24) cause the safety option module and drive Enable circuit to trip and the motor coast-to-stop. To restart the drive, the Guardmaster safety relay must first be reset followed by a valid start command to the drive.
Fault detection	A single fault that is detected on the Guardmaster safety input circuits results in the lockout of the system at the next operation and does not cause loss of the safety function.

Figure 9 - Stop Category 0

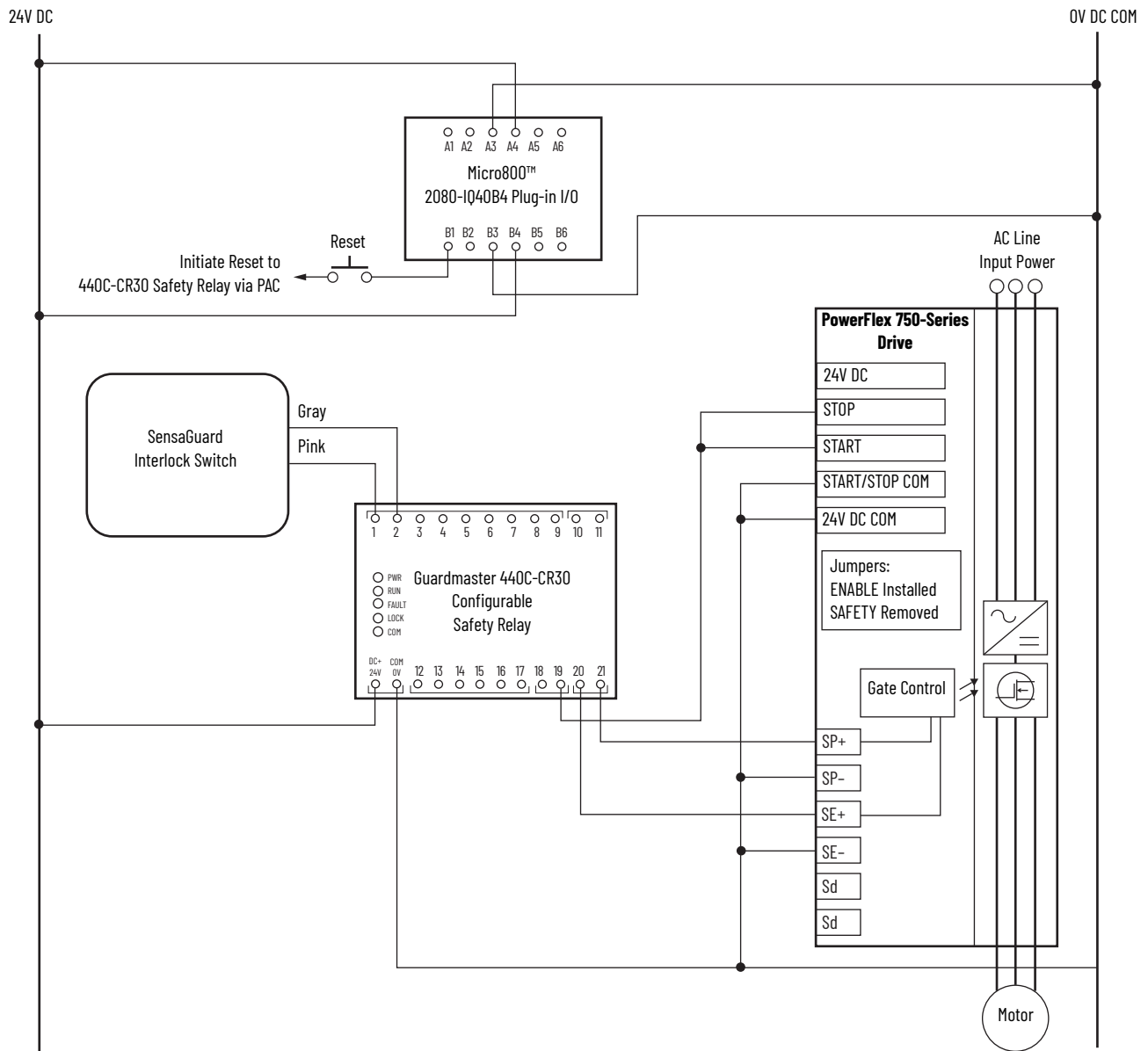

Table 9 - Guardmaster Configurable Relay Example Summary

Attribute	Description
Circuit status	Circuit is shown with guard door closed and system ready for normal drive operation.
Operating principle	This is a dual-channel system with monitoring of the Safe Torque Off circuit and drive. Monitoring is software configurable by using Connected Components Workbench software. Opening the guard door switches the input circuits (1 and 2) to the Guardmaster monitoring safety relay. The output circuits (19, 20, and 21) cause the drive Enable circuit to trip and the motor coast-to-stop. To restart the drive, the Guardmaster safety relay must first be reset followed by a valid start command to the drive.
Application Considerations	When the hazard analysis for the overall machine determines the need for external mechanical brakes or other stopping means, the external means shall be activated after the removal of power for Stop Category 0. If the safety option module sticks ON, the motor stops on command due to the enable input. The system cannot be reset when this fault condition exists.

Figure 10 - Stop Category 1

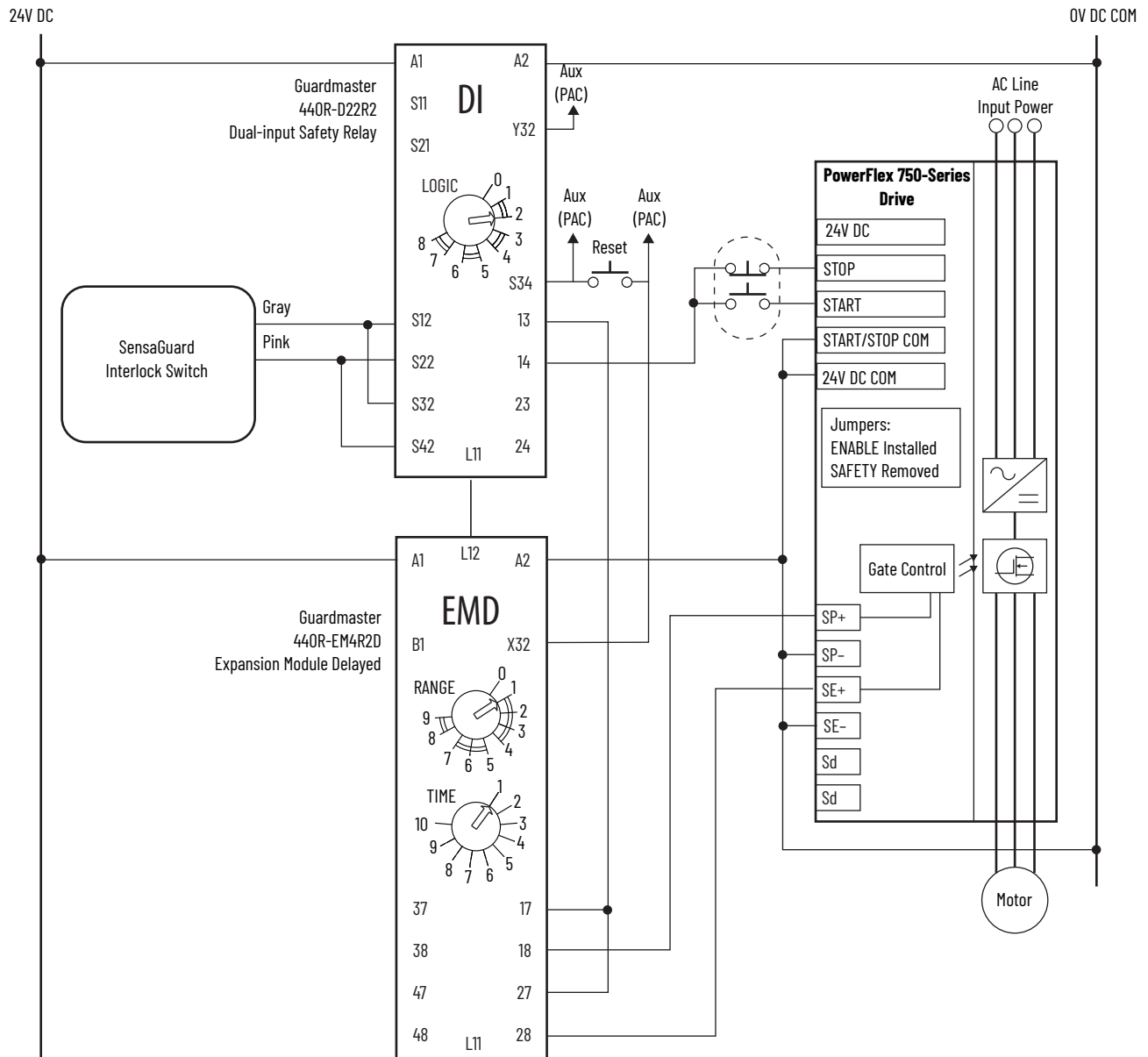

Table 10 - Guardmaster DI and EMD Example Summary

Attribute	Description
Circuit status	Circuit is shown with guard door closed and system ready for normal drive operation.
Operating principle	This is a dual-channel system with monitoring of the Safe Torque Off circuit and drive. Opening the guard door switches the input circuits (S12, S22, and S32, S42) to the Guardmaster monitoring safety relay. The output circuits (13, 14) issue a Stop command to the drive and cause a controlled deceleration. After the programmed delay, the timed output circuits (17, 18 and 27, 28) cause the Safe Torque Off option module and the drive Enable circuit to trip. If the motor is rotating when the trip occurs, it will coast-to-stop. To restart the drive, the Guardmaster safety relay must first be reset followed by a valid start command to the drive.
Fault detection	A single fault that is detected on the Guardmaster safety input circuits results in the lockout of the system at the next operation and does not cause loss of the safety function. If the safety option module sticks ON, the motor stops on command due to the enable input. The system cannot be reset when this fault condition exists.

Figure 11 - Stop Category 0

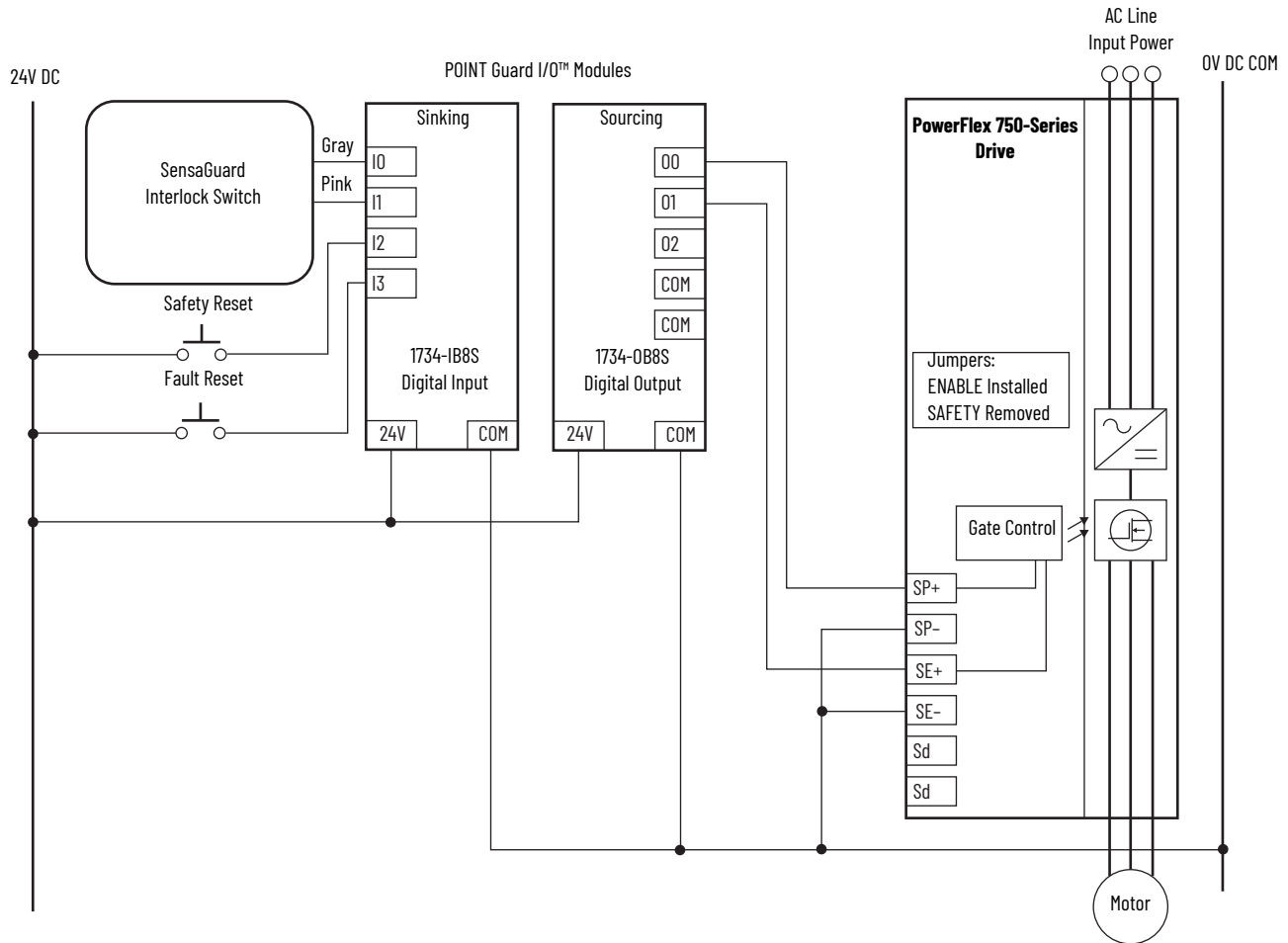

Table 11 - POINT Guard I/O Example Summary

Attribute	Description
Circuit status	Circuit is shown with guard door closed and system ready for normal drive operation.
Operating principle	When a partial-access guard door is opened, the safety system initiates and maintains a stop command to stop hazardous motion before a person can reach the hazardous area. The safety system cannot be reset, and hazardous motion cannot be restarted while the guard door is open. Once the guard door is closed and the stop command is reset, a valid start command is required before hazardous motion can resume.
Fault detection	The GuardLogix® controller-logic monitors the system for valid status and faults. When it receives a safety demand on its inputs or an invalid status or fault is detected, the GuardLogix controller-logic deactivates its safety outputs and sends a safety stop command. The PowerFlex drive monitors its internal safety circuits for valid status and faults. When the GuardLogix controller de-energizes the drive Safe Torque Off (STO) inputs, or an invalid state or fault is detected, the STO feature on the drive forces the drive output power transistors to a disabled state. The hazardous motion that is controlled by the drive coasts or ramps to a stop. This feature does not provide electrical power isolation.

## Specifications, Certifications, CE Conformity, and UKCA Conformity

This appendix provides general specifications for the PowerFlex® 750-Series Safe Torque Off option module.

Topic	Page
Specifications	29
Certifications	31
CE Conformity	31
UKCA Conformity	32

### Specifications

These specifications apply to the Safe Torque Off option module. For additional specifications, refer to the following publications:

- PowerFlex 750-Series AC Drives Technical Data, publication [750-TD001](#).
- PowerFlex 750-Series Products with TotalFORCE Control Technical Data, publication [750-TD100](#).
- PowerFlex 755TS Products with TotalFORCE Control Technical Data, publication [750-TD104](#).

**Table 12 - General Specifications**

Attribute	Value
Standards when used with PowerFlex 750-Series	IEC 61800-5-2, EN 61800-5-1, EN 61800-3, EN ISO 13849-1, EN 62061, EN 60204-1, IEC 61508 parts 1-7
Safety category when used with PowerFlex 750-Series	SIL 3 according to EN 62061 / IEC 61508 SIL CL 3 according to IEC 61800-5-2 / EN 62061 / IEC 61508 Cat. 4 and PL e according to EN ISO 13849-1
Standards when used with PowerFlex 750-Series with TotalFORCE Control	EN 61800-5-2, EN 61800-5-1, EN 61800-3, EN ISO 13849-1, EN 62061, EN 60204-1, IEC 61508 parts 1-7
Safety category when used with PowerFlex 750-Series with TotalFORCE Control	SIL 3 according to EN 62061 / IEC 61508 SIL CL 3 according to EN 61800-5-2 / EN 62061 / IEC 61508 Cat. 3 and PL e according to EN ISO 13849-1
Power supply (user I/O)	24V DC $\pm 10\%$ , 0.8...1.1 x rated voltage <sup>(1)</sup> PELV or SELV
Power consumption	4.4 W
Safety enable SE+, SE-	24V DC, 25 mA
Safety power SP+, SP-	24V DC, 45 mA
Input ON Voltage, min	24V DC $\pm 10\%$ , 21.6...26.4V DC
Input OFF Voltage, max	5V
Input OFF Current, max	2.5 mA @ 5V DC
Conductor type	Multi-conductor shielded cable
Conductor size <sup>(2)</sup>	0.3...0.8 mm <sup>2</sup> (28...18 AWG)
Strip length	10 mm (0.39 in.)

(1) Safety outputs need additional fuse for reverse voltage protection of the control circuit. Install a 6 A slow-blow or 10 A fast-acting fuse.

(2) See Industrial Automation Wiring and Grounding Guidelines, publication [1770-4.1](#).

## Environmental Specifications

The installation must comply with all environmental, pollution degree, and drive enclosure rating specifications required for the operating environment.

Category	Specification
Ambient temperature	For detailed information on environmental, pollution degree, and drive enclosure rating specifications, see the technical data publication for your drive. <ul style="list-style-type: none"> <li>PowerFlex 750-Series AC Drives Technical Data, publication <a href="#">750-TD001</a></li> <li>PowerFlex 750-Series Products with TotalFORCE Control Technical Data, publication <a href="#">750-TD100</a></li> <li>PowerFlex 755TM IPO0 Open Type Kits Technical Data, publication <a href="#">750-TD101</a></li> <li>PowerFlex 755TS Products with TotalFORCE Control Technical Data, publication <a href="#">750-TD104</a></li> </ul>
Storage temperature	
Shock Operating Packaged for shipment	
Vibration Operating Packaged for shipment Sinusoidal loose load Random secured	
Surrounding environment	
Corrosive Atmosphere (20-750-S-XT) <ul style="list-style-type: none"> <li>ASTM B845-97 Method K Accelerated Test (30 day exposure)</li> <li>Plus additional Rockwell Automation proprietary accelerated corrosion testing protocol for specific industries with sources of gaseous sulfur compounds, including tire and rubber.</li> </ul>	Severity Level GX per ANSI/ISA 71.03-2013, airborne contaminants-gases. Severity level GX is defined as up to 2100 angstroms of film growth per 30 days of copper ofr silver reactivity. Severity Level CX per IEC 60721-3-3: 2019, Chemically Active Substances. For the product to meet the corrosive atmosphere rating, these conditions must be met: <ul style="list-style-type: none"> <li>The PowerFlex 755T product has the Corrosive Gas Protection (XT) option.</li> <li>Protective covers must remain installed in unused connectors during storage and operation.</li> <li>The product or kit must be stored in the original packaging.</li> </ul>



**ATTENTION:** Failure to maintain the specified ambient temperature can result in a failure of the safety function.

**IMPORTANT** Products with a safety function installed must be protected against conductive contamination by one of the following methods:

- Select a product with an enclosure type of at least IP54, NEMA/UL Type 12
- Provide an environmentally controlled location for the product that does not contain conductive contamination

**Table 13 - Environmental Pollution Degree Description (EN 61800-5-1)**

Surrounding Environment Pollution Degree	Conductive Contamination Allowed by Pollution Degree	Acceptable Enclosures
Pollution degree 1 and 2	No possibility of conductive dust.	All enclosures are acceptable.
Pollution degree 3 and 4	The possibility of conductive dust is allowed.	Enclosure that meets or exceeds IPS4, NEMA/UL Type 12 is required.

## Certifications

See the Product Certifications website, [rok.auto/certifications](http://rok.auto/certifications) for Declarations of Conformity, Certificates, and other certifications details.

Certification <sup>(1)</sup>	Value
cULus <sup>(2)</sup>	UL Listed, certified for US and Canada.
CE	European Union 2014/30/EU EMC Directive, compliant with: EN 61800-3; PowerFlex 750-Series AC Drive, Emissions, and Immunity European Union 2006/42/EC Machinery Directive: EN ISO 13849-1; Safety Function EN ISO 13849-2; Safety Function EN 60204-1; Safety Function EN 62061; Safety Function EN 61800-5-2; Safety Function
RCM	Australian Radiocommunications Act, compliant with: EN 61800-3; categories C2 and C3
TÜV	Certified by TÜV Rheinland for Safety: Up to SIL 3, according to EN 61800-5-2, and IEC 61508, and SIL CL3 according to EN IEC 62061; up to Performance Level PLe and Category 3, according to EN ISO 13849-1; when used as described in this PowerFlex 750-Series Safe Torque Off User Manual, publication <a href="#">750-UM002</a> .
UKCA	UK Electromagnetic Compatibility Regulations (EMC) 2016 No. 1091, compliant with: EN 61800-3; PowerFlex 750-Series AC Drive, Emissions, and Immunity UK Supply of Machinery (Safety) Regulations (MD) 2008 No. 1597: EN ISO 13849-1; Safety Function EN ISO 13849-2; Safety Function EN 60204-1; Safety Function EN 62061; Safety Function EN 61800-5-2; Safety Function

(1) When product is marked, refer to [rok.auto/certifications](http://rok.auto/certifications) for Declarations of Conformity Certificates.

(2) Underwriters Laboratories Inc. has not evaluated the Safe Torque Off, or Safe Speed Monitor option modules for safety.

## CE Conformity

CE Declarations of Conformity are available online at: the Product Certifications website, [rok.auto/certifications](http://rok.auto/certifications).

The 20-750-S and 20-750-S-XT Safe Torque Off option modules are in conformity with the essential requirements of the 2006/42/EC Machinery Directive and the 2014/30/EU EMC Directive when installed and maintained in accordance with the instructions that are contained in this document. The following standards have been applied to demonstrate conformity:

### Machinery Directive (2006/42/EC)

- EN ISO 13849-1 Safety of machinery - Safety-related parts of control systems - Part 1: General principles for design
- EN 60204-1 Safety of machinery - Electrical equipment of machines - Part 1: General requirements
- EN 62061 Safety of machinery - Functional safety of safety-related electrical, electronic, and programmable electronic control systems
- EN 61800-5-2 Adjustable speed electrical power drive systems - Part 5-2: Safety requirements - Functional
- IEC 61508 Part 1...7 Functional safety of electrical/electronic/programmable electronic safety-related systems

### EMC Directive (2014/30/EU)

- EN 61800-3 - Adjustable speed electric power drive systems - Part 3: EMC requirements and specific test methods

## UKCA Conformity

UKCA Declarations of Conformity are available online at: the Product Certifications website, [rok.auto/certifications](http://rok.auto/certifications).

The 20-750-S and 20-750-S-XT Safe Torque Off option modules are in conformity with the UK Supply of Machinery (Safety) Regulation (MD) 2008 No. 1597 and the UK Electromagnetic Compatibility Regulations (EMC) 2016 No. 1091 when installed and maintained in accordance with the instructions that are contained in this document. The following standards have been applied to demonstrate conformity:

### **UK Supply of Machinery (Safety) Regulation (MD) 2008 No. 1597**

- EN ISO 13849-1 Safety of machinery - Safety-related parts of control systems - Part 1: General principles for design
- EN 60204-1 Safety of machinery - Electrical equipment of machines - Part 1: General requirements
- EN 62061 Safety of machinery - Functional safety of safety-related electrical, electronic, and programmable electronic control systems
- EN 61800-5-2 Adjustable speed electrical power drive systems - Part 5-2: Safety requirements - Functional
- IEC 61508 Part 1...7 Functional safety of electrical/electronic/programmable electronic safety-related systems

### **UK Electromagnetic Compatibility Regulation (EMC) 2016 No. 1091**

- EN 61800-3 - Adjustable speed electric power drive systems - Part 3: EMC requirements and specific test methods

## History of Changes

### Change Log

This appendix contains the new or updated information for each revision of this publication. These lists include substantive updates only and are not intended to reflect all changes. Translated versions are not always available for each revision.

#### 750-UM002B-EN-P, March 2009

---

**Change**

---

Safety concept section added

---

Figure 3 corrected

---

Figure 4 corrected

---

Certificate updated

---

Appendix A added

---

#### 750-UM002C-EN-P, December 2010

---

**Change**

---

PowerFlex® Frame 8 drive information added

---

PFD and PFH for 20-year Proof Test Interval table updated

---

Details on hardware enable jumper added

---

Port 6 installation requirement for Integrated Motion applications added to Important statement

---

Tip added explaining how module operation is verified

---

Required jumper settings added to connection examples

---

#### 750-UM002D-EN-P, September 2011

---

**Change**

---

PFD and PFH for 20-year Proof Test Interval table updated

---

Indicated shielded conductors required

---

#### 750-UM002E-EN-P, February 2012

---

**Change**

---

Drive Frames 1 and 10 added

---

PFD and PFH for 20-year Proof Test Interval table updated

---

Important installation notes added

---

Environmental Specifications added

---

Compliance clarified under CE in Certifications section

---

Evaluations and Certifications are not listed in this publication

---

#### 750-UM002F-EN-P, July 2013

---

**Change**

---

Accumulation of faults statement removed from Safety Category 3 performance definition

---

Stop Category 2 removed from Stop Category definitions

---

PFD and PFH values adjusted for Frame 8 drives

---

Important note added to Safety Reaction Time section

---

Power Supply Requirements added to Wiring section

---

Information added to Important statement under Verify Operation

---

Standards expanded under General Specifications

---

**750-UM002G-EN-P, February 2016****Change**

Revised Environmental Specifications to include 477 A rating

Revised figures in Chapter 4 to show SP- and SE- wired to the external power supply +24V DC

**750-UM002H-EN-P, February 2017****Change**

Added safety specifications (including PFD and PFH values) for PowerFlex 755T drive products

Updated the Safe State information and added Safety Reaction Time specifications for PowerFlex 755T drive products

Updated Access the Drive Control Pod with references to PowerFlex 755T drive products

Updated jumper setting figures and added figure for PowerFlex 755T drive products

Added Remove Power From the Drive System

Updated Stop Category Wiring Examples with Guardmaster® safety relays

Added Stop Category Wiring Example with POINT Guard I/O™ modules

Updated Environmental Specifications table

**750-UM002I-EN-P, August 2019****Change**

Added definitions for DCavg%, and MTTFD to the Terminology table

Updated the definitions of PELV, PFH, and SELV in the Terminology table

Added the PowerFlex 750-Series AC Drives Technical Data publication to the Additional Resources table

Updated the definition of PFH in PFD and PFH Definitions section

Changed the PFD and PFH data section to Safety Data section

Added IMPORTANT statement to Safety Data section for determination of safety parameters

Added rows for MTTFDyears and DCavg% data to PFD and PFH for PowerFlex 753 and PowerFlex 755 Drives table and PFD and PFH for PowerFlex 755T Drive Products table

Added columns for Drive Frames 5 and 6, Drive Frames 7 and 8, Drive Frame 13, Drive Frame 14, and Drive Frame 15 to PFD and PFH for PowerFlex 755T Drive Products table

Updated the list of supported drive families in the Safety Reaction Time table

Updated the Remove Power to the System section in the Installation and Wiring chapter

Updated the Access the Control Pod section

Updated the Set the Safety Enable Jumper section - mentioned Safety Jumper In fault (F213)

Added an Important note to the Install the Safety Option Module section

Added parameter 10:351 [M Start Inhibits] for the PowerFlex 755T to the Operation section

Updated the drive families examples in Stop Category Wiring Examples section

Updated Standards and Safety Categories in the General Specifications table to show card certifications when used with the PowerFlex 750-Series and when used with the PowerFlex 750-Series with TotalFORCE Control

Updated Certifications table to show latest Directive number

**750-UM002J-EN-P, February 2021****Change**

Updated Important statement in the Set the Safety Enable Jumper section to describe behavior if jumper is not set correctly and list drives which do not have the jumper

Added Environmental Pollution Degree Description (EN 61800-5-1) table to Appendix A

**750-UM002K-EN-P, December 2021****Change**

Added catalog number 20-750-S-XT to preface

Added Corrosive Atmosphere (20-750-S-XT) information row to the Environment specification table

**750-UM002L-EN-P, April 2022****Change**

---

Updated name of PFD to PFDavg

---

Added PowerFlex 755TS AC drives to applicable drives in Preface

---

Added PowerFlex 755TS Products with TotalFORCE Control Installation Instructions, publication 750-IN119 to the Additional Resources table

---

Added PowerFlex 755TS Products with TotalFORCE Control Technical Data, publication 750-TD104 to the Additional Resources table

---

Added PFDavg and PFH for PowerFlex 755TS Drives table to Safety Data section

---

Added PowerFlex 755TS Drive Products Jumper Locations figure to the Set the Safety Enable Jumper section

---

**750-UM002M-EN-P, November 2022****Change**

---

Parameter conventions clarified

---

Added the PowerFlex TotalFORCE Firmware Revisions 10.xxx and Later Documentation Set to the Additional Resources table

---

Clarified the PowerFlex 755TS Drives Jumper Locations graphic

---

UKCA added to Certifications

---

UKCA conformity section added

---

**750-UM002N-EN-P, July 2023****Change**

---

Updated configuration steps for the hardware enable and safety enable jumpers

---

**750-UM002O-EN-P, January 2025****Change**

---

PowerFlex 755TR liquid cooled drive, frame 6L added to Table 2

---

PowerFlex 755TS, frame 7A added to Table 3

---

PowerFlex 755TR liquid cooled drive, frame 6L added to Table 4

---

PowerFlex 755TS, frame 7A added to Table 4

---

PowerFlex 755TR liquid cooled drive, frame 6L added to Stop Category Wiring Examples

---

PowerFlex 755TS, frame 7A added to Stop Category Wiring Examples

---

**Notes:**

**A**

**additional resources** 7  
**Australian Radiocommunications Act** 31

**C**

**cat. 3** 5  
**CE** 31  
**certification**  
     cat. 3 5  
     CE 31  
     cULus 31  
     PLe 5  
     RCM 31  
     SIL CL3 5  
     TÜV 31  
     UKCA 32  
**cULus** 31

**D**

**documentation**  
     additional resources 7

**E**

**electrical shock hazard** 16  
**EMC Directive**  
     2014/30/EU 31  
     2016 No. 1091 32  
**EN 61508-5-2** 31  
**encoder wire** 21  
**European Norm**  
     definition 6

**F**

**functional proof test** 10

**G**

**guidelines**  
     wire 21

**H**

**hardware enable jumper** 17  
**hazard**  
     electrical shock 16

**I**

**ISO 13849-1** 31

**J**

**jumper**  
     hardware enable 17

**M**

**Machinery Directive (2006/42/EC)** 31

**P**

**parameter**  
     10 351 M Start Inhibits 23  
     933 Start Inhibits 23  
**PFD**  
     definition 6  
**PFH**  
     definition 6  
**PL**  
     definition 6  
**PLe** 5, 31  
**probability of failure on demand** 6  
**probability of failure per hour** 6  
**proof test**  
     20 year interval 11  
     functional 10  
     interval 10

**R**

**RCM** 31

**S**

**Safe State** 12  
**Safety Integrity Level**  
     SIL CL3 5  
**safety reaction time** 13  
**SIL CL3** 5, 31

**T**

**TÜV** 31

**U**

**UK Supply of Machinery Reg 2008 No. 1597** 32  
**UKCA** 32

**W**

**wire**  
     encoder 21  
**wire guidelines** 21

**Notes:**



# Rockwell Automation Support

Use these resources to access support information.

<b>Technical Support Center</b>	Find help with how-to videos, FAQs, chat, user forums, Knowledgebase, and product notification updates.	<a href="http://rok.auto/support">rok.auto/support</a>
<b>Local Technical Support Phone Numbers</b>	Locate the telephone number for your country.	<a href="http://rok.auto/phonesupport">rok.auto/phonesupport</a>
<b>Technical Documentation Center</b>	Quickly access and download technical specifications, installation instructions, and user manuals.	<a href="http://rok.auto/techdocs">rok.auto/techdocs</a>
<b>Literature Library</b>	Find installation instructions, manuals, brochures, and technical data publications.	<a href="http://rok.auto/literature">rok.auto/literature</a>
<b>Product Compatibility and Download Center (PCDC)</b>	Download firmware, associated files (such as AOP, EDS, and DTM), and access product release notes.	<a href="http://rok.auto/pcdc">rok.auto/pcdc</a>

## Documentation Feedback

Your comments help us serve your documentation needs better. If you have any suggestions on how to improve our content, complete the form at [rok.auto/docfeedback](http://rok.auto/docfeedback).

## Waste Electrical and Electronic Equipment (WEEE)



At the end of life, this equipment should be collected separately from any unsorted municipal waste.





Rockwell Automation maintains current product environmental compliance information on its website at [rok.auto/pec](http://rok.auto/pec).

Allen-Bradley, Connected Components Workbench, expanding human possibility, GuardLogix, Guardmaster, Micro800, POINT Guard I/O, PowerFlex, Rockwell Automation, SensaGuard, and TotalFORCE are trademarks of Rockwell Automation, Inc.

EtherNet/IP is a trademark of ODVA, Inc.

Trademarks not belonging to Rockwell Automation are property of their respective companies.

Rockwell Otomasyon Ticaret A.Ş. Kar Plaza İş Merkezi E Blok Kat:6 34752, İçerenköy, İstanbul, Tel: +90 (216) 5698400 EEE Yönetmeliğine Uygundur

Connect with us.    

**rockwellautomation.com** ————— **expanding human possibility®**

AMERICAS: Rockwell Automation, 1201 South Second Street, Milwaukee, WI 53204-2496 USA, Tel: (1) 414.382.2000

EUROPE/MIDDLE EAST/AFRICA: Rockwell Automation NV, Pegasus Park, De Kleetlaan 12a, 1831 Diegem, Belgium, Tel: (32) 2663 0600

ASIA PACIFIC: Rockwell Automation SEA Pte Ltd, 2 Corporation Road, #04-05, Main Lobby, Corporation Place, Singapore 618494, Tel: (65) 6510 6608

UNITED KINGDOM: Rockwell Automation Ltd., Pitfield, Kiln Farm, Milton Keynes, MK11 3DR, United Kingdom, Tel: (44)(1908) 838-800

Publication 750-UM002P-EN-P - January 2026

Supersedes Publication 750-UM0020-EN-P - January 2025

Copyright © 2026 Rockwell Automation, Inc. All rights reserved. Printed in the U.S.A.