

Installation Instructions

Original Instructions



Allen-Bradley

by ROCKWELL AUTOMATION

FLEX 5000 Interconnect Cable

Catalog Numbers 5094-CE05, 5094-CE07, 5094-CE10, 5094-CE30

| Topic | Page |
|---------------------------------------|------|
| Summary of Changes | 1 |
| Product Overview | 1 |
| About the Cable | 4 |
| Mounting Requirements | 4 |
| Install the Cable | 6 |
| Remove the Cable | 9 |
| Install End Anchors onto the DIN Rail | 11 |
| Specifications | 11 |
| Additional Resources | 11 |

Summary of Changes

This publication contains the following new or updated information. This list includes substantive updates only and is not intended to reflect all changes.

| Topic | Page |
|-------------------------|------|
| Updated section Spacing | 5 |

Product Overview

The FLEX 5000® interconnect cable performs the following functions:

- Separate the FLEX 5000 I/O system into two banks of modules.
- Provide system-side power to FLEX 5000 I/O modules.



ATTENTION: Read this document and the documents listed in the Additional Resources section about installation, configuration and operation of this equipment before you install, configure, operate or maintain this product. Users are required to familiarize themselves with installation and wiring instructions in addition to requirements of all applicable codes, laws, and standards.

Activities including installation, adjustments, putting into service, use, assembly, disassembly, and maintenance are required to be carried out by suitably trained personnel in accordance with applicable code of practice. If this equipment is used in a manner not specified by the manufacturer, the protection provided by the equipment may be impaired.

注意：在安装、配置、操作和维护本产品前，请阅读本文档以及“其他资源”部分列出的有关设备安装、配置和操作的相应文档。除了所有适用规范、法律和标准的相关要求之外，用户还必须熟悉安装和接线说明。

安装、调整、投运、使用、组装、拆卸和维护等各项操作必须由经过适当训练的专业人员按照适用的操作规范实施。

如果未按照制造商指定的方式使用该设备，则可能会损害设备提供的保护。

ATENCIÓN: Antes de instalar, configurar, poner en funcionamiento o realizar el mantenimiento de este producto, lea este documento y los documentos listados en la sección Recursos adicionales acerca de la instalación, configuración y operación de este equipo. Los usuarios deben familiarizarse con las instrucciones de instalación y cableado y con los requisitos de todos los códigos, leyes y estándares vigentes.

El personal debidamente capacitado debe realizar las actividades relacionadas a la instalación, ajustes, puesta en servicio, uso, ensamblaje, desensamblaje y mantenimiento de conformidad con el código de práctica aplicable. Si este equipo se usa de una manera no especificada por el fabricante, la protección provista por el equipo puede resultar afectada.

ATENÇÃO: Leia este e os demais documentos sobre instalação, configuração e operação do equipamento que estão na seção Recursos adicionais antes de instalar, configurar, operar ou manter este produto. Os usuários devem se familiarizar com as instruções de instalação e fiação além das especificações para todos os códigos, leis e normas aplicáveis.

É necessário que as atividades, incluindo instalação, ajustes, colocação em serviço, utilização, montagem, desmontagem e manutenção sejam realizadas por pessoal qualificado e especializado, de acordo com o código de prática aplicável.

Caso este equipamento seja utilizado de maneira não estabelecida pelo fabricante, a proteção fornecida pelo equipamento pode ficar prejudicada.

ВНИМАНИЕ: Перед тем как устанавливать, настраивать, эксплуатировать или обслуживать данное оборудование, прочитайте этот документ и документы, перечисленные в разделе «Дополнительные ресурсы». В этих документах изложены сведения об установке, настройке и эксплуатации данного оборудования. Пользователи обязаны ознакомиться с инструкциями по установке и прокладке соединений, а также с требованиями всех применимых норм, законов и стандартов.

Все действия, включая установку, наладку, ввод в эксплуатацию, использование, сборку, разборку и техническое обслуживание, должны выполняться обученным персоналом в соответствии с применимыми нормами и правилами.

Если оборудование используется не предусмотренным производителем образом, защита оборудования может быть нарушена.

注意：本製品を設置、構成、稼働または保守する前に、本書および本機器の設置、設定、操作についての参考資料の該当箇所に記載されている文書に目を通してください。ユーザーは、すべての該当する条例、法律、規格の要件に加えて、設置および配線の手順に習熟している必要があります。

設置調整、運転の開始、使用、組立て、解体、保守を含む諸作業は、該当する実施規則に従って訓練を受けた適切な作業員が実行する必要があります。

本機器が製造メーカーにより指定されていない方法で使用されている場合、機器により提供されている保護が損なわれる恐れがあります。

ACHTUNG: Lesen Sie dieses Dokument und die im Abschnitt „Weitere Informationen“ aufgeführten Dokumente, die Informationen zu Installation, Konfiguration und Bedienung dieses Produkts enthalten, bevor Sie dieses Produkt installieren, konfigurieren, bedienen oder warten. Anwender müssen sich neben den Bestimmungen aller anwendbaren Vorschriften, Gesetze und Normen zusätzlich mit den Installations- und Verdrahtungsanweisungen vertraut machen.

Arbeiten im Rahmen der Installation, Anpassung, Inbetriebnahme, Verwendung, Montage, Demontage oder Instandhaltung dürfen nur durch ausreichend geschulte Mitarbeiter und in Übereinstimmung mit den anwendbaren Ausführungsvorschriften vorgenommen werden.

Wenn das Gerät in einer Weise verwendet wird, die vom Hersteller nicht vorgesehen ist, kann die Schutzfunktion beeinträchtigt sein.

ATTENTION : Lisez ce document et les documents listés dans la section Ressources complémentaires relatifs à l'installation, la configuration et le fonctionnement de cet équipement avant d'installer, configurer, utiliser ou entretenir ce produit. Les utilisateurs doivent se familiariser avec les instructions d'installation et de câblage en plus des exigences relatives aux codes, lois et normes en vigueur. Les activités relatives à l'installation, le réglage, la mise en service, l'utilisation, l'assemblage, le démontage et l'entretien doivent être réalisées par des personnes formées selon le code de pratique en vigueur.

Si cet équipement est utilisé d'une façon qui n'a pas été définie par le fabricant, la protection fournie par l'équipement peut être compromise.

주의：본 제품 설치, 설정, 작동 또는 유지 보수하기 전에 본 문서를 포함하여 설치, 설정 및 작동에 관한 참고 자료 섹션의 문서들을 반드시 읽고 숙지하십시오. 사용자는 모든 관련 규정, 법규 및 표준에서 요구하는 사항에 대해 반드시 설치 및 배선 지침을 숙지해야 합니다.

설치, 조정, 가동, 사용, 조립, 분해, 유지보수 등 모든 작업은 관련 규정에 따라 적절한 교육을 받은 사용자가 통해서만 수행해야 합니다.

본 장비를 제조사가 명시하지 않은 방법으로 사용하면 장비의 보호 기능이 손상될 수 있습니다.

ATTENZIONE Prima di installare, configurare ed utilizzare il prodotto, o effettuare interventi di manutenzione su di esso, leggere il presente documento ed i documenti elencati nella sezione "Altre risorse", riguardanti l'installazione, la configurazione ed il funzionamento dell'apparecchiatura. Gli utenti devono leggere e comprendere le istruzioni di installazione e cablaggio, oltre ai requisiti previsti dalle leggi, codici e standard applicabili.

Le attività come installazione, regolazioni, utilizzo, assemblaggio, disassemblaggio e manutenzione devono essere svolte da personale adeguatamente addestrato, nel rispetto delle procedure previste. Qualora l'apparecchio venga utilizzato con modalità diverse da quanto previsto dal produttore, la sua funzione di protezione potrebbe venire compromessa.

DIKKAT: Bu ürünün kurulumu, yapılandırılması, işletilmesi veya bakımı öncesinde bu dokümanı ve bu ekipmanın kurulumu, yapılandırılması ve işletimi ile ilgili ilave Kaynaklar bölümünde yer listelenmiş dokümanları okuyun. Kullanıcılar yürürlükteki tüm yönetmelikler, yasalar ve standartların gereksinimlerine ek olarak kurulum ve kablolama talimatlarını da öğrenmek zorundadır.

Kurulum, ayarlama, hizmete alma, kullanma, parçaları birleştirme, parçaları sökme ve bakım gibi aktiviteler sadece uygun eğitimleri almış kişiler tarafından yürürlükteki uygulama yönetmeliklerine uygun şekilde yapılabilir.

Bu ekipman üretici tarafından belirlenmiş amacın dışında kullanılırsa, ekipman tarafından sağlanan koruma bozulabilir.

注意事項：在安装、設定、操作或維護本產品前，請先閱讀此文件以及列於「其他資源」章節中有關安裝、設定與操作此設備的文件。使用者必須熟悉安裝和配線指示，並符合所有法規、法律和標準要求。

包括安裝、調整、交付使用、使用、組裝、拆卸和維護等動作都必須交由已經過適當訓練的人員進行，以符合適用的實作法規。

如果將設備用於非製造商指定的用途時，可能會造成設備所提供的保護功能受損。

POZOR: Než začnete instalovat, konfigurovat či provázovat tento výrobek nebo provádět jeho údržbu, přečtěte si tento dokument a dokumenty uvedené v části Dodatečné zdroje ohledně instalace, konfigurace a provozu tohoto zařízení. Uživatelé se musejí vedle požadavků všech relevantních vyhlášek, zákonů a norem nutně seznámit také s pokyny pro instalaci a elektrické zapojení.

Činnost zahrnující instalaci, nastavení, uvedení do provozu, užívání, montáž, demontáž a údržbu musí vykonávat vhodně proškolený personál v souladu s příslušnými prováděcími předpisy.

Pokud se toto zařízení používá způsobem neodpovídajícím specifikaci výrobce, může být narušena ochrana, kterou toto zařízení poskytuje.

UWAGA: Przed instalacją, konfiguracją, użytkowaniem lub konserwacją tego produktu należy przeczytać niniejszy dokument oraz wszystkie dokumenty wymienione w sekcji Dodatkowe źródła omawiające instalację, konfigurację i procedury użytkowania tego urządzenia. Użytkownicy mają obowiązek zapoznać się z instrukcjami dotyczącymi instalacji oraz oprzewodowania, jak również z obowiązującymi kodeksami, prawem i normami.

Działania obejmujące instalację, regulację, przekazanie do użytkowania, użytkowanie, montaż, demontaż oraz konserwację muszą być wykonywane przez odpowiednio przeszkolony personel zgodnie z obowiązującym kodeksem postępowania.

Jeśli urządzenie jest użytkowane w sposób inny niż określony przez producenta, zabezpieczenie zapewniane przez urządzenie może zostać ograniczone.

OBES! Läs detta dokument samt dokumentet, som står listat i avsnittet Övriga resurser, om installation, konfigurering och drift av denna utrustning innan du installerar, konfigurerar eller börjar använda eller utföra underhållsarbete på produkten. Användare måste bekanta sig med instruktioner för installation och kabeldragning, förutom krav enligt gällande koder, lagar och standarder.

Åtgärder som installation, justering, service, användning, montering, demontering och underhållsarbete måste utföras av personal med lämplig utbildning enligt lämpligt bruk.

Om denna utrustning används på ett sätt som inte anges av tillverkaren kan det hända att utrustningens skyddsanordningar försätts ur funktion.

LET OP: Lees dit document en de documenten die genoemd worden in de paragraaf Aanvullende informatie over de installatie, configuratie en bediening van deze apparatuur voordat u dit product installeert, configureert, bedient of onderhoudt. Gebruikers moeten zich vertrouwd maken met de installatie en de bedringsinstructies, naast de vereisten van alle toepasselijke regels, wetten en normen.

Activiteiten zoals het installeren, afstellen, in gebruik stellen, gebruiken, monteren, demonteren en het uitvoeren van onderhoud mogen uitsluitend worden uitgevoerd door hiervoor opgeleid personeel en in overeenstemming met de geldende praktijkregels.

Indien de apparatuur wordt gebruikt op een wijze die niet is gespecificeerd door de fabrikant, dan bestaat het gevaar dat de beveiliging van de apparatuur niet goed werkt.





ATTENTION: Personnel responsible for the application of safety-related programmable electronic systems (PES) shall be aware of the safety requirements in the application of the system and shall be trained in using the system.

IMPORTANT

Any illustrations, charts, sample programs, and layout examples that are shown in this publication are intended solely for the purposes of example. Since there are many variables and requirements that are associated with any particular installation, Rockwell Automation does not assume responsibility or liability for actual use based on the examples that are shown in this publication.

North American Hazardous Location Approval

| The following information applies when operating this equipment in hazardous locations. | Informations sur l'utilisation de cet équipement en environnements dangereux. |
|--|--|
| <p>Products marked "CL I, DIV 2, GP A, B, C, D" are suitable for use in Class I Division 2 Groups A, B, C, D, Hazardous Locations and nonhazardous locations only. Each product is supplied with markings on the rating nameplate indicating the hazardous location temperature code. When combining products within a system, the most adverse temperature code (lowest "T" number) may be used to help determine the overall temperature code of the system. Combinations of equipment in your system are subject to investigation by the local Authority Having Jurisdiction at the time of installation.</p> | <p>Les produits marqués "CL I, DIV 2, GP A, B, C, D" ne conviennent qu'à une utilisation en environnements de Classe I Division 2 Groupes A, B, C, D dangereux et non dangereux. Chaque produit est livré avec des marquages sur sa plaque d'identification qui indiquent le code de température pour les environnements dangereux. Lorsque plusieurs produits sont combinés dans un système, le code de température le plus défavorable (code de température le plus faible) peut être utilisé pour déterminer le code de température global du système. Les combinaisons d'équipements dans le système sont sujettes à inspection par les autorités locales qualifiées au moment de l'installation.</p> |
| <div style="display: flex; align-items: center;">  <div> <p>WARNING: Explosion Hazard -</p> <ul style="list-style-type: none"> Do not disconnect equipment unless power has been removed or the area is known to be nonhazardous. Do not disconnect connections to this equipment unless power has been removed or the area is known to be nonhazardous. Secure any external connections that mate to this equipment by using screws, sliding latches, threaded connectors, or other means provided with this product. Substitution of components may impair suitability for Class I Division 2. </div> </div> | <div style="display: flex; align-items: center;">  <div> <p>AVERTISSEMENT: Risque d'Explosion -</p> <ul style="list-style-type: none"> Couper le courant ou s'assurer que l'environnement est classé non dangereux avant de débrancher l'équipement. Couper le courant ou s'assurer que l'environnement est classé non dangereux avant de débrancher les connecteurs. Fixer tous les connecteurs externes reliés à cet équipement à l'aide de vis, loquets coulissants, connecteurs filetés ou autres moyens fournis avec ce produit. La substitution de composants peut rendre cet équipement inadapté à une utilisation en environnement de Classe I Division 2. </div> </div> |

UK and European Hazardous Location Approval

| |
|--|
| <p>The following applies to products marked  II 3 G:</p> <ul style="list-style-type: none"> Are Equipment Group II, Equipment Category 3, and comply with the Essential Health and Safety Requirements relating to the design and construction of such equipment that is given in Schedule 1 of UKEX Regulation 2016 No. 1107 and Annex II of EU Directive 2014/34/EU. See the UKEx and EU Declaration of Conformity at rok.auto/certifications for details. The type of protection is Ex ec IIC T4 Gc according to EN IEC 60079-0:2018, EXPLOSIVE ATMOSPHERES - PART 0: EQUIPMENT - GENERAL REQUIREMENTS and EN IEC 60079-7:2015+A1:2018, Explosive atmospheres - Equipment protection by increased safety "e". Comply with Standard EN IEC 60079-0:2018, EXPLOSIVE ATMOSPHERES - PART 0: EQUIPMENT - GENERAL REQUIREMENTS, EN IEC 60079-7:2015+A1:2018 Explosive atmospheres - Equipment protection by increased safety "e", reference certificate number DEMK017ATEX1898X & UL22UKEX2654X. Are intended for use in areas in which explosive atmospheres caused by gases, vapors, mists, or air are unlikely to occur, or are likely to occur only infrequently and for short periods. Such locations correspond to Zone 2 classification according to UKEX regulation 2016 No. 1107 and ATEX directive 2014/34/EU. |
|--|

IEC Hazardous Location Approval

| |
|--|
| <p>The following applies to products with IECEx certification: Such modules:</p> <ul style="list-style-type: none"> Are intended for use in areas in which explosive atmospheres caused by gases, vapors, mists, or air are unlikely to occur, or are likely to occur only infrequently and for short periods. Such locations correspond to Zone 2 classification to IEC 60079-0. The type of protection is Ex ec IIC T4 Gc according to IEC 60079-0 and IEC 60079-7. Comply with Standards IEC 60079-0, Explosive atmospheres Part 0: Equipment - General requirements, Edition 7, Revision Date 2017, IEC 60079-7, 5.1 Edition revision date 2017, Explosive atmospheres - Part 7: Equipment protection by increased safety "e", reference IECEx certificate number IECEx UL17.0047X. |
|--|

Special Conditions for Safe Use

| |
|---|
| <div style="display: flex; align-items: center;">  <div> <p>WARNING:</p> <ul style="list-style-type: none"> This equipment shall be mounted in a UKEX/ATEX/IECEx Zone 2 certified enclosure with a minimum ingress protection rating of at least IP54 (in accordance with EN/IEC 60079-0) and used in an environment of not more than Pollution Degree 2 (as defined in EN/IEC 60664-1) when applied in Zone 2 environments. The enclosure must be accessible only by the use of a tool. This equipment shall be used within its specified ratings that are defined by Rockwell Automation. Transient protection shall be provided that is set at a level not exceeding 140% of the peak rated voltage value at the supply terminals to the equipment. The instructions in the user manual shall be observed. This equipment must be used only with UKEX/ATEX/IECEx certified Rockwell Automation backplanes. Secure any external connections that mate to this equipment by using screws, sliding latches, threaded connectors, or other means provided with this product. Do not disconnect equipment unless power has been removed or the area is known to be nonhazardous. Earthing is accomplished through mounting of modules on rail. The installer shall ensure that the service temperature of the suitably certified enclosure and the "maximum ambient" temperature of the module when installed is not exceeded. </div> </div> |
|---|

Prevent Electrostatic Discharge

| |
|--|
| <div style="display: flex; align-items: center;">  <div> <p>ATTENTION: This equipment is sensitive to electrostatic discharge, which can cause internal damage and affect normal operation. Follow these guidelines when you handle this equipment:</p> <ul style="list-style-type: none"> Touch a grounded object to discharge potential static. Wear an approved grounding wriststrap. Do not touch connectors or pins on component boards. Do not touch circuit components inside the equipment. Use a static-safe workstation, if available. Store the equipment in appropriate static-safe packaging when not in use. </div> </div> |
|--|



ATTENTION: This equipment is intended for use in a Pollution Degree 2 industrial environment, in overvoltage Category II applications (as defined in EN/IEC 60664-1), at altitudes up to 2000 m (6562 ft) without derating. This equipment is not intended for use in residential environments and may not provide adequate protection to radio communication services in such environments.

This equipment is supplied as open-type equipment for indoor use. It must be mounted within an enclosure that is suitably designed for those specific environmental conditions that will be present and appropriately designed to prevent personal injury resulting from accessibility to live parts. The enclosure must have suitable flame-retardant properties to prevent or minimize the spread of flame, complying with a flame spread rating of 5VA or be approved for the application if nonmetallic. The interior of the enclosure must be accessible only by the use of a tool. Subsequent sections of this publication may contain additional information regarding specific enclosure type ratings that are required to comply with certain product safety certifications.

In addition to this publication, see the following:

- Industrial Automation Wiring and Grounding Guidelines, publication [1770-4.1](#), for more installation requirements.
- NEMA Standard 250 and EN/IEC 60529, as applicable, for explanations of the degrees of protection provided by enclosures.

About the Cable

Dimensions

Measurements are in mm (in.)

5094-CE05, 5094-CE10, 5094-CE30
With fixed ferrite core

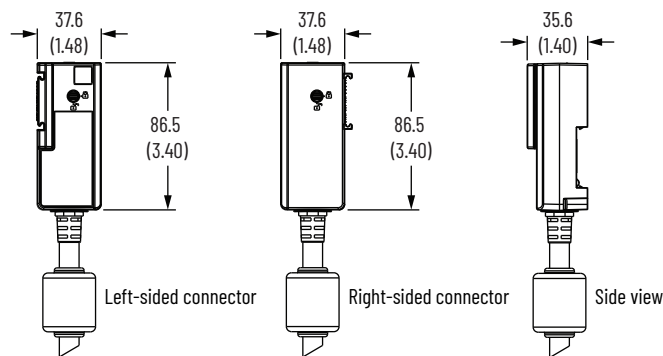

5094-CE07
With snap-on ferrite core
In cabinet use only

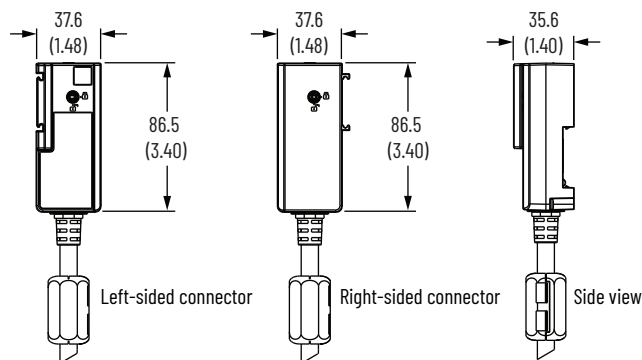

FLEX 5000 interconnect cable comes in four cable lengths: 0.5 meter (1.6 feet), 0.7 meter (2.3 feet), 1 meter (3.3 feet), and 3 meters (10 feet).

Mounting Requirements

Follow these requirements when installing a FLEX 5000 interconnect cable in your FLEX 5000 I/O system.

- A FLEX 5000 I/O system supports up to two banks of modules up to the maximum supported by the adapter, which are connected with the cable.
- Tie excess cable lengths into a loop, and route it in the wireways or secure them to the panel.
- For 5094-CE05, 5094-CE10, and 5094-CE30:
 - Do not bend the cable to a radius smaller than 50 mm (2 in.).
 - Make sure that there is a minimum cable length of 80 mm (3.1 in.) from the base of either connector to the closest bend.
- For 5094-CE07:



ATTENTION: Use only with a FLEX 5000 I/O system that is installed in a grounded and closed metal enclosure.

- Do not bend the cable to a radius smaller than 40 mm (1.6 in.).
- Make sure that there is a minimum cable length of 5 mm (0.2 in.) from the base of either ferrite core to the closest bend.

Measurements are in mm (in.)

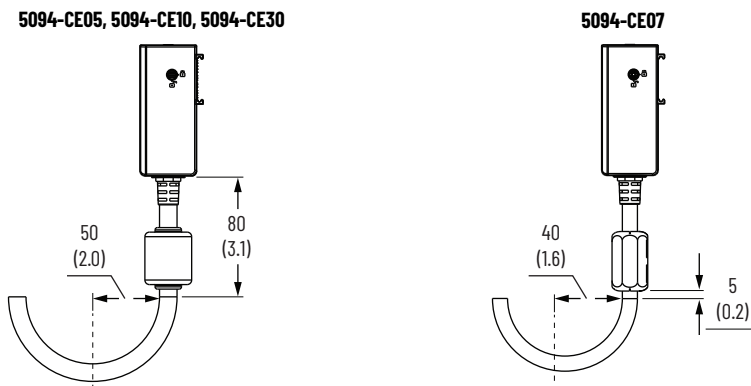

Reposition the Snap-on Ferrite Core

The 5094-CE07 interconnect cable ships with the snap-on ferrite cores installed. You can adjust the position of the ferrite cores as required for your system installation.

Measurements are in mm (in.)



1. To open the ferrite core, release the latch on the housing.
2. Position the ferrite core 25.4...76.2 mm (1.0...3.0 in.) from the base of the connector.
3. Close the ferrite core and verify that it is locked in place.

Spacing

Maintain spacing from enclosure walls, wireways, and adjacent equipment. Allow 25.4 mm (1.00 in.) of space on all sides of the system for adequate ventilation. Accessories such as the shield bar (5094-STB) and interconnect cable (5094-CEx) do not affect ventilation and are not included in the clearance requirement.

You can mount the DIN rail horizontally or vertically.

FLEX 5000 I/O Mounting Clearance Requirements

Measurements are in mm (in.)

Horizontal Mounting

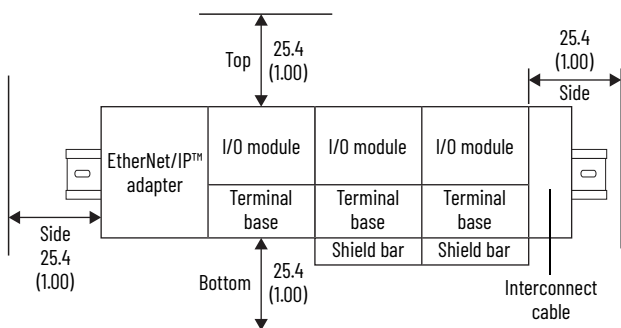

Vertical Mounting

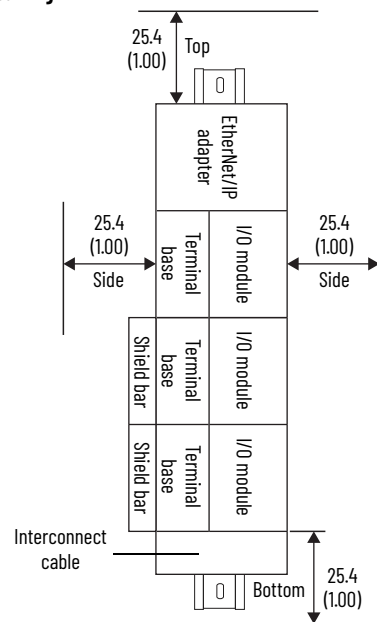

Ground Considerations

You must ground DIN rails according to the Industrial Automation Wiring and Grounding Guidelines, publication [1770-4.1](#).



ATTENTION: This product is grounded through the DIN rail to chassis ground. Use zinc-plated chromate-passivated steel DIN rail to assure proper grounding. The use of other DIN rail materials (for example, aluminum or plastic) that can corrode, oxidize, or are poor conductors, can result in improper or intermittent grounding. Secure DIN rail to mounting surface approximately every 200 mm (7.8 in.) and use end-anchors appropriately. Be sure to ground the DIN rail properly. See Industrial Automation Wiring and Grounding Guidelines, Rockwell Automation publication [1770-4.1](#) for more information.

You can use a zinc-plated chromated steel DIN rail such as the Allen-Bradley® 199-DRT; 46277-3; EN 60715 - 35 x 7.5 mm (1.38 x 0.30 in.) with your FLEX 5000 I/O system.

Remove the End Cap



ATTENTION: Do not discard the end cap. Use this end cap to cover the exposed interconnections on the last terminal base on the DIN rail. Failure to do so could result in equipment damage or injury from electric shock.

1. Make sure that the end cap is unlocked.
If the end cap is locked, pull the tab until it clicks.

Locked

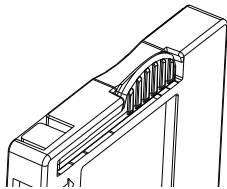

Unlocked

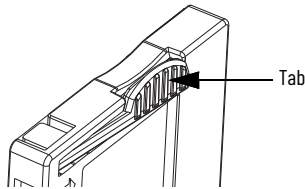

2. Slide the end cap away from the DIN rail.

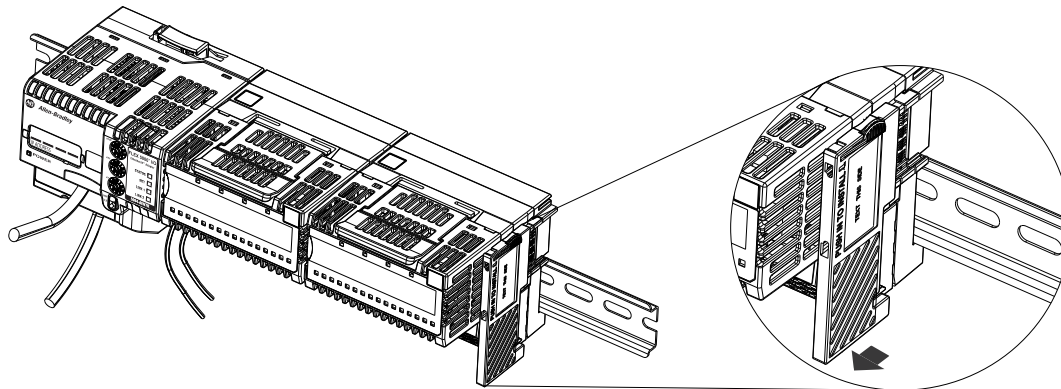

Install the Cable

The FLEX 5000 interconnect cable is installed on existing DIN rail-mounted modules. The procedure to install the cable is different depending on whether the system is powered on or off.



The 5094-CE05 cable is shown in the following examples, however the steps to install the cable are identical for all catalogs.

To install the cable while:

- The system is off, see [Install the Cable to a System Without Power on page 7](#).
- The system is on, see [Install the Cable to a System With Power on page 8](#).

Install the Cable to a System Without Power

1. Remove backplane power from the two banks of modules that you want to connect with the cable.
2. For the first bank of modules, slide the left-sided connector onto the mating connector on the right side of the last terminal base assembly. Press firmly until the connector clicks onto the DIN rail and the locking screw is in the lock position.

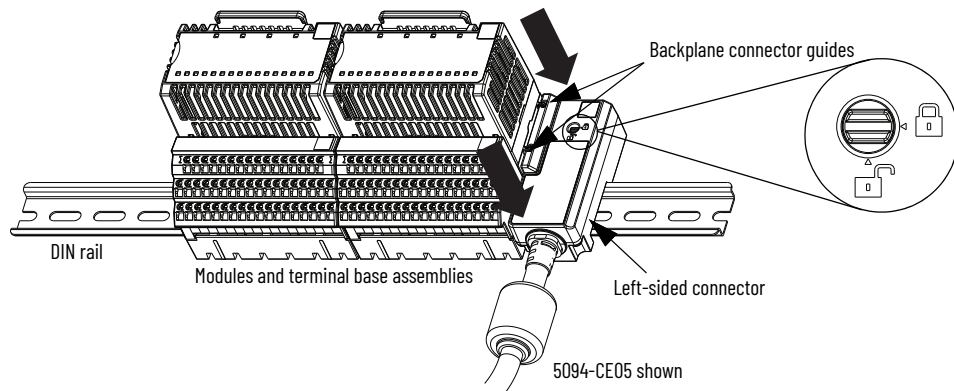

3. For the second bank of modules, remove the I/O module from the first terminal base assembly.
4. Slide the right-sided connector onto the mating connector on the left side of the first terminal base assembly. Press firmly until the connector clicks onto the DIN rail and the locking screw is in the lock position.

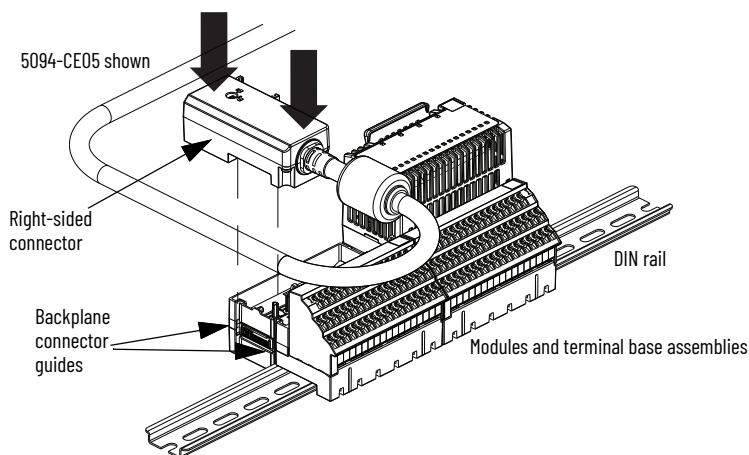

5. Remount the I/O module onto the terminal base assembly.

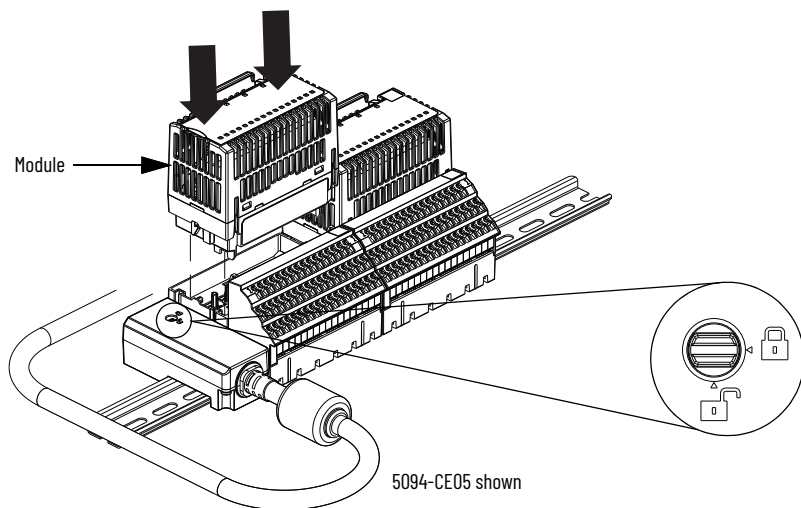

6. Route excess cable lengths in the wireways or secure them to the panel.

Install the Cable to a System With Power



WARNING:

When you insert or remove the module while backplane power is on, an electric arc can occur. This could cause an explosion in hazardous location installations. Be sure that power is removed or the area is nonhazardous before proceeding. Repeated electric arcing causes excessive wear to contacts on both the module and its mating connector. Worn contacts may create electrical resistance that can affect module operation.

1. For the first bank of modules, slide the left-sided connector onto the mating connector on the right side of the last terminal base assembly. Press firmly until the connector clicks onto the DIN rail and the locking screw is in the lock position.

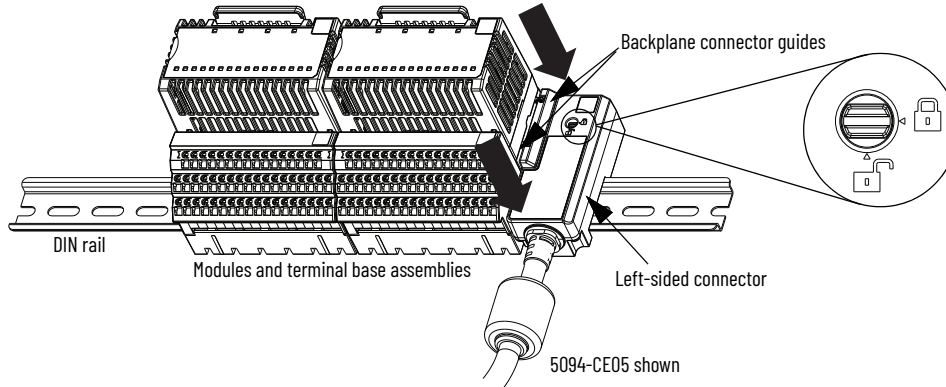

2. For the second bank of modules, remove all I/O modules before proceeding.
3. Slide the right-sided connector onto the mating connector on the left side of the first terminal base assembly. Press firmly until the connector clicks onto the DIN rail and the locking screw is in the lock position.

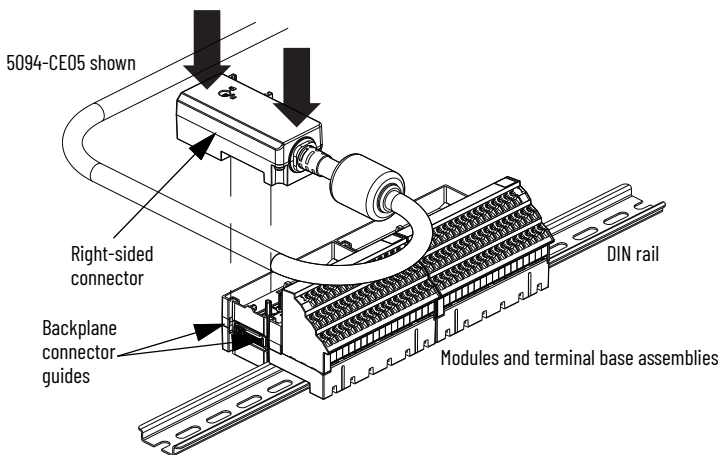

4. Remount the I/O module onto the terminal base assembly.

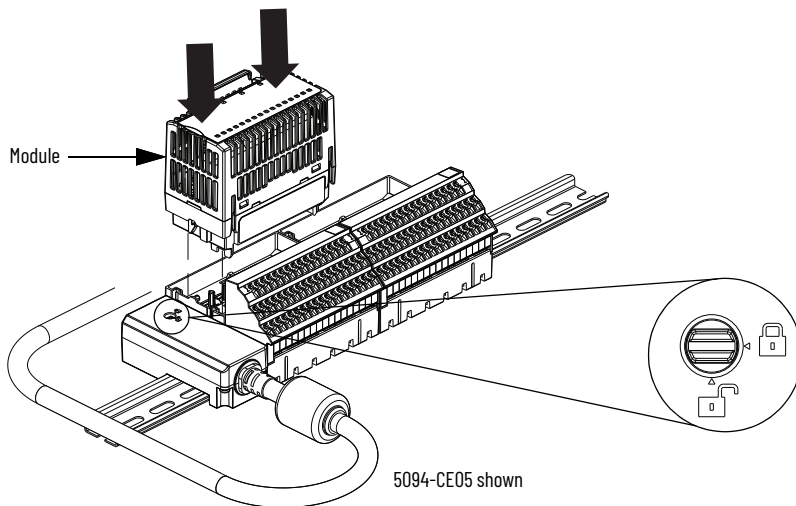

5. Route excess cable lengths in the wireways or secure them to the panel.
6. Remount the remaining I/O modules in the second bank.

Remove the Cable

The procedure to remove the cable is different depending on whether the system is powered on or off.



The 5094-CE05 cable is shown in the following examples, however the steps to remove the cable are identical for all catalogs.

To remove the cable while:

- The system is off, see [Remove the Cable from a System Without Power on page 9.](#)
- The system is on, see [Remove the Cable from a System With Power on page 10.](#)

Remove the Cable from a System Without Power

1. Remove backplane power from both banks of modules.
2. Remove the I/O module from the first terminal base assembly in the second bank.
3. Turn the locking screw on the right-sided connector to the unlock position with a flat-tip screwdriver.

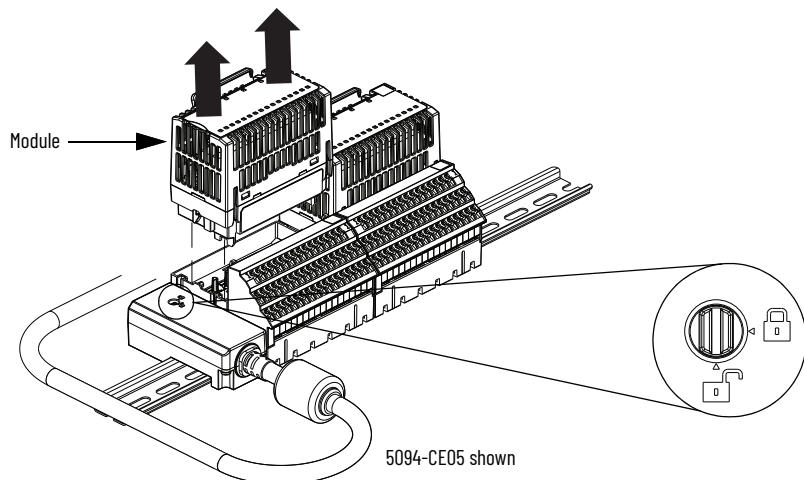

4. Remove the right-sided connector from the terminal base assembly.

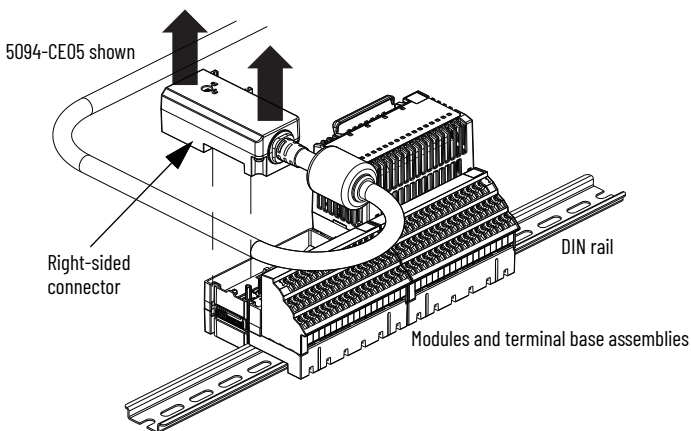

5. Turn the locking screw on the left-sided connector to the unlock position with a flat-tip screwdriver.

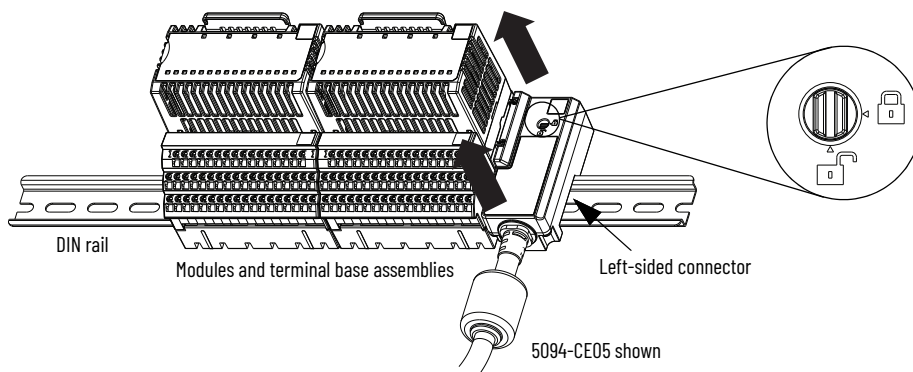

6. Remove the left-sided connector from the terminal base assembly.
7. Install an end cap onto the terminal base assembly.

Remove the Cable from a System With Power



WARNING: When you insert or remove the module while backplane power is on, an electric arc can occur. This could cause an explosion in hazardous location installations. Be sure that power is removed or the area is nonhazardous before proceeding. Repeated electric arcing causes excessive wear to contacts on both the module and its mating connector. Worn contacts may create electrical resistance that can affect module operation.

1. Remove all I/O modules from the second bank.
2. Turn the locking screw on the right-sided connector to the unlock position with a flat-tip screwdriver.

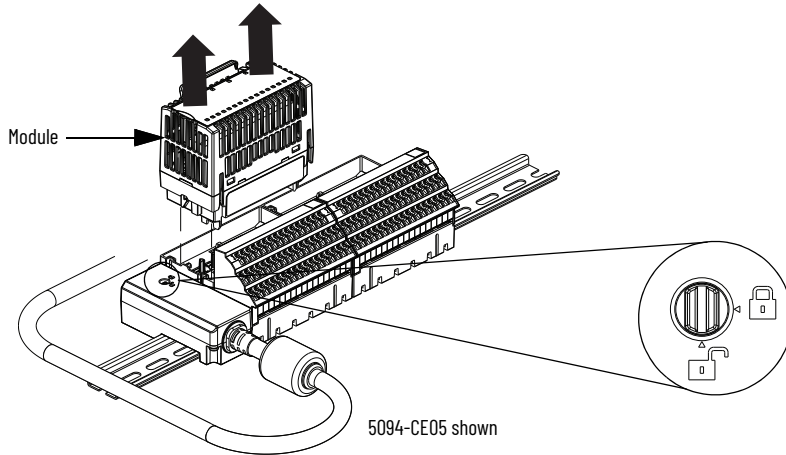

3. Remove the right-sided connector from the terminal base assembly.

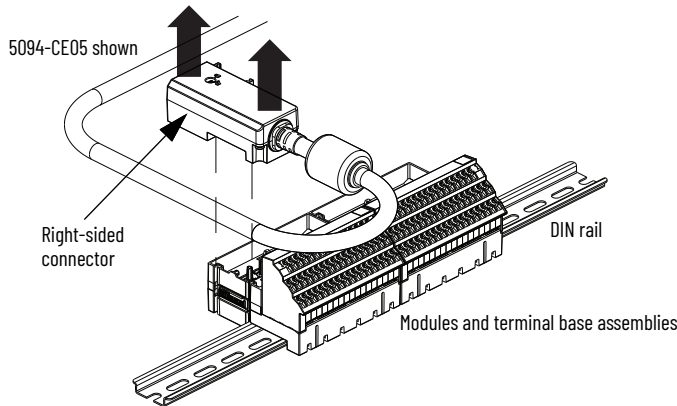

4. Turn the locking screw on the left-sided connector to the unlock position with a flat-tip screwdriver.

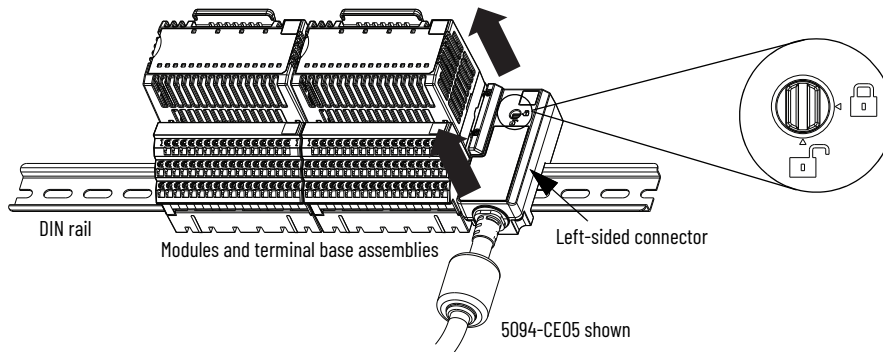

5. Remove the left-sided connector from the terminal base assembly.
6. Install an end cap onto the terminal base assembly.

Install End Anchors onto the DIN Rail

Use DIN rail end anchors (Allen-Bradley part number 1492-EAJ35 or 1492-EAHJ35) for vibration or shock environments. You must install an end anchor on both ends of your system to hold the modules firmly in position on the DIN rail.

1. Make sure that the end cap is installed on the last module in the second bank.
2. Slide an end anchor along the left-side of the DIN rail until it touches the adapter in the first bank.
3. Slide an end anchor along the right-side of the DIN rail until it touches the left-sided connector in the first bank.
4. Slide an end anchor along the left-side of the DIN rail until it touches the right-sided connector in the second bank.
5. Slide an end anchor along the right-side of the DIN rail until it touches the end cap on the last module in the second bank.
6. Tighten the screw of each end anchor.

Specifications

The following table lists a subset of the cable specifications. For a complete list of specifications, see the FLEX 5000 Module Specifications Technical Data, publication [5094-TD001](#).

Table 1 - FLEX 5000 Interconnect Cables General Specifications - 5094-CE05, 5094-CE07, 5094-CE10, 5094-CE30

| Attribute | 5094-CE05, 5094-CE10, 5094-CE30 | 5094-CE07 |
|---|--|--|
| Temperature, operating IEC 60068-2-1 (Test Ad, Operating Cold) IEC 60068-2-2 (Test Bd, Operating Dry Heat) IEC 60068-2-14 (Test Nb, Operating Thermal Shock) | -40 °C ≤ Ta ≤ +70 °C (-40 °F ≤ Ta ≤ +158 °F) | |
| Temperature, surrounding air, max | 70 °C (158 °F) | |
| Enclosure type rating | None (open-style) | ATTENTION: Use only with a FLEX 5000 I/O system that is installed in a grounded and closed metal enclosure. |
| Backplane power (BP), max | 1.8 A @ 15V DC | |
| Cable length | 5094-CE05 - 0.5 m (1.6 ft) 5094-CE10 - 1.0 m (3.3 ft) 5094-CE30 - 3.0 m (10 ft) | 0.7 m (2.3 ft) |
| Weight, approx | 5094-CE05 - 390 g (13.8 oz.) 5094-CE10 - 497 g (17.5 oz.) 5094-CE30 - 933 g (32.9 oz.) | 311 g (11.0 oz.) |
| North American temp code | T4 | |
| UKEX/ATEX temp code | T4 | |
| IECEX temp code | T4 | |
| Corrosion resistance classification | ISA S71.04 G3 | |

Additional Resources

For more information on the products that are described in this publication, use these resources. You can view or download publications at rok.auto/literature.

| Resource | Description |
|--|---|
| FLEX 5000 Module Specifications Technical Data, publication 5094-TD001 | Provides FLEX 5000 EtherNet/IP adapters and FLEX 5000 I/O module specifications. |
| Industrial Automation Wiring and Grounding Guidelines, publication 1770-4.1 | Provides general guidelines for installing a Rockwell Automation industrial system. |
| Product Certifications website, rok.auto/certifications | Provides declarations of conformity, certificates, and other certification details. |

Rockwell Automation Support

Use these resources to access support information.

| | | |
|---|---|--|
| Technical Support Center | Find help with how-to videos, FAQs, chat, user forums, Knowledgebase, and product notification updates. | rok.auto/support |
| Local Technical Support Phone Numbers | Locate the telephone number for your country. | rok.auto/phonesupport |
| Technical Documentation Center | Quickly access and download technical specifications, installation instructions, and user manuals. | rok.auto/techdocs |
| Literature Library | Find installation instructions, manuals, brochures, and technical data publications. | rok.auto/literature |
| Product Compatibility and Download Center (PCDC) | Download firmware, associated files (such as AOP, EDS, and DTM), and access product release notes. | rok.auto/pcdc |

Documentation Feedback

Your comments help us serve your documentation needs better. If you have any suggestions on how to improve our content, complete the form at rok.auto/docfeedback.





Waste Electrical and Electronic Equipment (WEEE)



At the end of life, this equipment should be collected separately from any unsorted municipal waste.

Rockwell Automation maintains current product environmental compliance information on its website at rok.auto/pec.

Rockwell Otomasyon Ticaret A.Ş. Kar Plaza İş Merkezi E Blok Kat:6 34752 İçerenköy, İstanbul, Tel: +90 (216) 5698400 EEE Yönetmeliğine Uygundur

Connect with us.    

rockwellautomation.com — expanding **human possibility**[®]

AMERICAS: Rockwell Automation, 1201 South Second Street, Milwaukee, WI 53204-2496 USA, Tel: (1) 414.382.2000

EUROPE/MIDDLE EAST/AFRICA: Rockwell Automation NV, Pegasus Park, De Kleetlaan 12a, 1831 Diegem, Belgium, Tel: (32) 2663 0600

ASIA PACIFIC: Rockwell Automation SEA Pte Ltd, 2 Corporation Road, #04-05, Main Lobby, Corporation Place, Singapore 618494, Tel: (65) 6510 6608

UNITED KINGDOM: Rockwell Automation Ltd., Pitfield, Kiln Farm, Milton Keynes, MK11 3DR, United Kingdom, Tel: (44)(1908) 838-800

Allen-Bradley, expanding human possibility, FLEX 5000, Rockwell Automation, and TechConnect are trademarks of Rockwell Automation, Inc.

EtherNet/IP is a trademark of ODVA, Inc.

Trademarks not belonging to Rockwell Automation are property of their respective companies.

Publication 5094-IN011D-EN-P - March 2025 | Supersedes Publication 5094-IN011C-EN-P - December 2023

Copyright © 2025 Rockwell Automation, Inc. All rights reserved. Printed in Singapore.

PN-728454