



FLEX I/O-XT 8-Input Channel Isolated HART Analog Module

Catalog Number 1794-IF8IHNFXT

Topic	Page
Summary of Changes	1
Install the Module	5
Wire the Module	6
Ground the Module	6
Module Wiring	7
Cyclic HART Input Data	10
Status Indicator	11
Specifications	11
Additional Resources	13

Summary of Changes

This publication contains the following new or updated information. This list includes substantive updates only and is not intended to reflect all changes.

Topic	Page
Deleted redundant step from the topic Wire the Module	6
Added ambient temperature attribute in General Specifications table	12
Updated Certifications	13
Updated Additional Resources	13



ATTENTION: Read this document and the documents listed in the Additional Resources section about installation, configuration and operation of this equipment before you install, configure, operate or maintain this product. Users are required to familiarize themselves with installation and wiring instructions in addition to requirements of all applicable codes, laws, and standards.

Activities including installation, adjustments, putting into service, use, assembly, disassembly, and maintenance are required to be carried out by suitably trained personnel in accordance with applicable code of practice. If this equipment is used in a manner not specified by the manufacturer, the protection provided by the equipment may be impaired.

注意：在安装、配置、操作和维护本产品前，请阅读本文档以及“其他资源”部分列出的有关设备安装、配置和操作的相应文档。除了所有适用规范、法律和标准的相关要求之外，用户还必须熟悉安装和接线说明。

安装、调整、投运、使用、组装、拆卸和维护等各项操作必须由经过适当训练的专业人员按照适用的操作规范实施。

如果未按制造商指定的方式使用该设备，则可能会损害设备提供的保护。

ATENCIÓN: Antes de instalar, configurar, poner en funcionamiento o realizar el mantenimiento de este producto, lea este documento y los documentos listados en la sección Recursos adicionales acerca de la instalación, configuración y operación de este equipo. Los usuarios deben familiarizarse con las instrucciones de instalación y cableado y con los requisitos de todos los códigos, leyes y estándares vigentes.

El personal debidamente capacitado debe realizar las actividades relacionadas a la instalación, ajustes, puesta en servicio, uso, ensamblaje, desensamblaje y mantenimiento de conformidad con el código de práctica aplicable. Si este equipo se usa de una manera no especificada por el fabricante, la protección provista por el equipo puede resultar afectada.

ATENÇÃO: Leia este e os demais documentos sobre instalação, configuração e operação do equipamento que estão na seção Recursos adicionais antes de instalar, configurar, operar ou manter este produto. Os usuários devem se familiarizar com as instruções de instalação e fiação além das especificações para todos os códigos, leis e normas aplicáveis.

É necessário que as atividades, incluindo instalação, ajustes, colocação em serviço, utilização, montagem, desmontagem e manutenção sejam realizadas por pessoal qualificado e especializado, de acordo com o código de prática aplicável.

Caso este equipamento seja utilizado de maneira não estabelecida pelo fabricante, a proteção fornecida pelo equipamento pode ficar prejudicada.

ВНИМАНИЕ: Перед тем как устанавливать, настраивать, эксплуатировать или обслуживать данное оборудование, прочитайте этот документ и документы, перечисленные в разделе «Дополнительные ресурсы». В этих документах изложены сведения об установке, настройке и эксплуатации данного оборудования. Пользователи обязаны ознакомиться с инструкциями по установке и прокладке соединений, а также с требованиями всех применимых норм, законов и стандартов.

Все действия, включая установку, наладку, ввод в эксплуатацию, использование, сборку, разборку и техническое обслуживание, должны выполняться обученным персоналом в соответствии с применимыми нормами и правилами.

Если оборудование используется не предусмотренным производителем образом, защита оборудования может быть нарушена.

注意：本製品を設置、構成、稼働または保守する前に、本書および本機器の設置、設定、操作についての参考資料の該当箇所に記載されている文書に目を通してください。ユーザは、すべての該当する条例、法律、規格の要件に加えて、設置および配線の手順に習熟している必要があります。

設置調整、運転の開始、使用、組立て、解体、保守を含む諸作業は、該当する実施規則に従って訓練を受けた適切な作業員が実行する必要があります。

本機器が製造メーカーにより指定されていない方法で使用されている場合、機器により提供されている保護が損なわれる恐れがあります。

ACHTUNG: Lesen Sie dieses Dokument und die im Abschnitt „Weitere Informationen“ aufgeführten Dokumente, die Informationen zu Installation, Konfiguration und Bedienung dieses Produkts enthalten, bevor Sie dieses Produkt installieren, konfigurieren, bedienen oder warten. Anwender müssen sich neben den Bestimmungen aller anwendbaren Vorschriften, Gesetze und Normen zusätzlich mit den Installations- und Verdrahtungsanweisungen vertraut machen.

Arbeiten im Rahmen der Installation, Anpassung, Inbetriebnahme, Verwendung, Montage, Demontage oder Instandhaltung dürfen nur durch ausreichend geschulte Mitarbeiter und in Übereinstimmung mit den anwendbaren Ausführungsvorschriften vorgenommen werden.

Wenn das Gerät in einer Weise verwendet wird, die vom Hersteller nicht vorgesehen ist, kann die Schutzfunktion beeinträchtigt sein.

ATTENTION : Lisez ce document et les documents listés dans la section Ressources complémentaires relatifs à l'installation, la configuration et le fonctionnement de cet équipement avant d'installer, configurer, utiliser ou entretenir ce produit. Les utilisateurs doivent se familiariser avec les instructions d'installation et de câblage en plus des exigences relatives aux codes, lois et normes en vigueur. Les activités relatives à l'installation, le réglage, la mise en service, l'utilisation, l'assemblage, le démontage et l'entretien doivent être réalisées par des personnes formées selon le code de pratique en vigueur.

Si cet équipement est utilisé d'une façon qui n'a pas été définie par le fabricant, la protection fournie par l'équipement peut être compromise.

주의：본 제품 설치, 설정, 작동 또는 유지보수하기 전에 본 문서를 포함하여 설치, 설정 및 작동에 관한 참고 자료 섹션의 문서들을 반드시 읽고 숙지하십시오. 사용자는 모든 관련 규정, 법규 및 표준에서 요구하는 사항에 대해 반드시 설치 및 배선 지침을 숙지해야 합니다.

설치, 조정, 가동, 사용, 조립, 분해, 유지보수 등 모든 작업은 관련 규정에 따라 적절한 교육을 받은 사용자를 통해서만 수행해야 합니다.

본 장비를 제조사가 명시하지 않은 방법으로 사용하면 장비의 보호 기능이 손상될 수 있습니다.

ATTENZIONE Prima di installare, configurare ed utilizzare il prodotto, o effettuare interventi di manutenzione su di esso, leggere il presente documento ed i documenti elencati nella sezione "Altre risorse", riguardanti l'installazione, la configurazione ed il funzionamento dell'apparecchiatura. Gli utenti devono leggere e comprendere le istruzioni di installazione e cablaggio, oltre ai requisiti previsti dalle leggi, codici e standard applicabili.

Le attività come installazione, regolazioni, utilizzo, assemblaggio, disassemblaggio e manutenzione devono essere svolte da personale adeguatamente addestrato, nel rispetto delle procedure previste. Qualora l'apparecchio venga utilizzato con modalità diverse da quanto previsto dal produttore, la sua funzione di protezione potrebbe venire compromessa.

DIKKAT: Bu ürünün kurulumu, yapılandırılması, işletilmesi veya bakımı öncesinde bu dokümanı ve bu ekipmanın kurulumu, yapılandırılması ve işletimi ile ilgili ilave Kaynaklar bölümünde yer listelenmiş dokümanları okuyun. Kullanıcılar yürürlükteki tüm yönetmelikler, yasalar ve standartların gereksinimlerine ek olarak kurulum ve kablolama talimatlarını da öğrenmek zorundadır.

Kurulum, ayarlama, hizmete alma, kullanma, parçaları birleştirme, parçaları sökme ve bakım gibi aktiviteler sadece uygun eğitimleri almış kişiler tarafından yürürlükteki uygulama yönetmeliklerine uygun şekilde yapılabilir.

Bu ekipman üretici tarafından belirlenmiş amacın dışında kullanılırsa, ekipman tarafından sağlanan koruma bozulabilir.

注意事項：在安装、設定、操作或維護本產品前，請先閱讀此文件以及列於「其他資源」章節中有關安裝、設定與操作此設備的文件。使用者必須熟悉安裝和配線指示，並符合所有法規、法律和標準要求。

包括安裝、調整、交付使用、使用、組裝、拆卸和維護等動作都必須交由已經過適當訓練的人員進行，以符合適用的實作法規。

如果將設備用於非製造商指定的用途時，可能會造成設備所提供的保護功能受損。

POZOR: Než začnete instalovat, konfigurovat či provozovat tento výrobek nebo provádět jeho údržbu, přečtěte si tento dokument a dokumenty uvedené v části Dodatečné zdroje ohledně instalace, konfigurace a provozu tohoto zařízení. Uživatelé se musejí vedle požadavků všech relevantních vyhlásek, zákonů a norem nutně seznámit také s pokyny pro instalaci a elektrické zapojení.

Činnosti zahrnující instalaci, nastavení, uvedení do provozu, užívání, montáž, demontáž a údržbu musí vykonávat vhodné proškolený personál v souladu s příslušnými prováděcími předpisy.

Pokud se toto zařízení používá způsobem neodpovídajícím specifikaci výrobce, může být narušena ochrana, kterou toto zařízení poskytuje.

UWAGA: Przed instalacją, konfiguracją, użytkowaniem lub konserwacją tego produktu należy przeczytać niniejszy dokument oraz wszystkie dokumenty wymienione w sekcji Dodatkowe źródła omawiające instalację, konfigurację i procedury użytkowania tego urządzenia. Użytkownicy mają obowiązek zapoznać się z instrukcjami dotyczącymi instalacji oraz przewodowania, jak również z obowiązującymi kodeksami, prawem i normami.

Działania obejmujące instalację, regulację, przekazanie do użytkowania, użytkowanie, montaż, demontaż oraz konserwację muszą być wykonywane przez odpowiednio przeszkolony personel zgodnie z obowiązującym kodeksem postępowania.

Jeśli urządzenie jest użytkowane w sposób inny niż określony przez producenta, zabezpieczenie zapewniane przez urządzenie może zostać ograniczone.

OBST! Läs detta dokument samt dokumentet, som står listat i avsnittet Övriga resurser, om installation, konfiguration och drift av denna utrustning innan du installerar, konfigurerar eller börjar använda eller utföra underhållsarbete på produkten. Användare måste bekanta sig med instruktioner för installation och kabeldragning, förutom krav enligt gällande koder, lagar och standarder.

Åtgärder som installation, justering, service, användning, montering, demontering och underhållsarbete måste utföras av personal med lämplig utbildning enligt lämpligt bruk.

Om denna utrustning används på ett sätt som inte anges av tillverkaren kan det hända att utrustningens skyddsanordningar försätts ur funktion.

LET OP: Lees dit document en de documenten die genoemd worden in de paragraaf Aanvullende informatie over de installatie, configuratie en bediening van deze apparatuur voordat u dit product installeert, configureert, bedient of onderhoudt. Gebruikers moeten zich vertrouwd maken met de installatie en de bedradingsinstructies, naast de vereisten van alle toepasselijke regels, wetten en normen.

Activiteiten zoals het installeren, afstellen, in gebruik stellen, gebruiken, monteren, demonteren en het uitvoeren van onderhoud mogen uitsluitend worden uitgevoerd door hiervoor opgeleid personeel en in overeenstemming met de geldende praktijkregels.

Indien de apparatuur wordt gebruikt op een wijze die niet is gespecificeerd door de fabrikant, dan bestaat het gevaar dat de beveiliging van de apparatuur niet goed werkt.

Environment and Enclosure



ATTENTION: This equipment is intended for use in a Pollution Degree 2 industrial environment, in overvoltage Category II applications (as defined in IEC 60664-1), at altitudes up to 2000 m (6562 ft) without derating.

This equipment is not intended for use in residential environments and may not provide adequate protection to radio communication services in such environments.

This equipment is supplied as open-type equipment. It must be mounted within an enclosure that is suitably designed for those specific environmental conditions that are present and appropriately designed to help prevent personal injury resulting from accessibility to live parts. The enclosure must have suitable flame-retardant properties to help prevent or minimize the spread of flame, complying with a flame spread rating of 5VA or be approved for the application if nonmetallic. The interior of the enclosure must be accessible only by the use of a tool. Subsequent sections of this publication may contain additional information regarding specific enclosure type ratings that are required to comply with certain product safety certifications.

In addition to this publication, see:

- Industrial Automation Wiring and Grounding Guidelines, publication [1770-4.1](#), for more installation requirements.
- NEMA Standard 250 and IEC 60529, as applicable, for explanations of the degrees of protection provided by different types of enclosure.

Prevent Electrostatic Discharge



ATTENTION: This equipment is sensitive to electrostatic discharge, which can cause internal damage and affect normal operation. Follow these guidelines when you handle this equipment:

- Touch a grounded object to discharge potential static.
- Wear an approved grounding wriststrap.
- Do not touch connectors or pins on component boards.
- Do not touch circuit components inside the equipment.
- Use a static-safe workstation, if available.
- Store the equipment in appropriate static-safe packaging when not in use.



ATTENTION: Personnel responsible for the application of safety-related programmable electronic systems (PES) shall be aware of the safety requirements in the application of the system and shall be trained in using the system.



ATTENTION: This product is grounded through the DIN rail to chassis ground. Use zinc-plated chromate-passivated steel DIN rail to assure proper grounding. The use of other DIN rail materials (for example, aluminum or plastic) that can corrode, oxidize, or are poor conductors, can result in improper or intermittent grounding. Secure DIN rail to mounting surface approximately every 200 mm (7.8 in.) and use end-anchors appropriately. Be sure to ground the DIN rail properly. See Industrial Automation Wiring and Grounding Guidelines, publication [1770-4.1](#), for more information.



ATTENTION: Do not remove or replace a Terminal Base unit when power is applied. Interruption of the backplane can result in unintentional operation or machine motion.



ATTENTION: If this equipment is used in a manner that is not specified by the manufacturer, the protection that is provided by the equipment may be impaired.

UK and European Hazardous Location Approval

The following applies to products marked II 3 G:

- Are Equipment Group II, Equipment Category 3, and comply with the Essential Health and Safety Requirements relating to the design and construction of such equipment given in Schedule 1 of UKEX Regulation 2016 No. 1107 and Annex II of EU Directive 2014/34/EU. See the UKEx and EU Declaration of Conformity at [rok.auto/certifications](#) for details.
- The type of protection is Ex ec IIC T4 Gc according to EN IEC 60079-0:2018, EXPLOSIVE ATMOSPHERES - PART 0: EQUIPMENT - GENERAL REQUIREMENTS & EN IEC 60079-7:2015+A1:2018, Explosive atmospheres - Equipment protection by increased safety "e".
- Comply with Standards EN IEC 60079-0:2018, EXPLOSIVE ATMOSPHERES - PART 0: EQUIPMENT - GENERAL REQUIREMENTS & EN IEC 60079-7:2015+A1:2018 Explosive atmospheres - Equipment protection by increased safety "e", reference certificate number UL 20 ATEX 2402X & UL22UKEX2488X.
- Are intended for use in areas in which explosive atmospheres caused by gases, vapors, mists, or air are unlikely to occur, or are likely to occur only infrequently and for short periods. Such locations correspond to Zone 2 classification according to UKEX regulation 2016 No. 1107 and ATEX directive 2014/34/EU.



WARNING: Observe the following additional Zone 2 certification requirements:

- This equipment is not resistant to sunlight or other sources of UV radiation.
- This equipment shall be mounted in an UKEX/ATEX/IECEX Zone 2 certified enclosure with a minimum ingress protection rating of at least IP54 (in accordance with EN/IEC 60079-0) and used in an environment of not more than Pollution Degree 2 (as defined in EN/IEC 60664-1) when applied in Zone 2 environments. The enclosure must be accessible only by the use of a tool.
- This equipment shall be used within its specified ratings that are defined by Rockwell Automation.
- Transient protection shall be provided that is set at a level not exceeding 140% of the peak-rated voltage value at the supply terminals to the equipment.
- Secure any external connections that mate to this equipment by using screws, sliding latches, threaded connectors, or other means provided with this product.
- Do not disconnect equipment unless power has been removed or the area is known to be nonhazardous.
- Earthing is accomplished through mounting of modules on rail.
- This equipment must be used only with UKEX/ATEX/IECEX certified backplanes.

IEC Hazardous Location Approval

The following applies to products with IECEx certification:

- Are intended for use in areas in which explosive atmospheres caused by gases, vapors, mists, or air are unlikely to occur, or are likely to occur only infrequently and for short periods. Such locations correspond to Zone 2 classification to IEC 60079-0.
- The type of protection is Ex ec IIC T4 Gc according to IEC 60079-0 and IEC 60079-7.
- Comply with Standards IEC 60079-0, Explosive atmospheres Part 0: Equipment - General requirements, Edition 7, Revision Date 2017, IEC 60079-7, 5.1 Edition revision date 2017, Explosive atmospheres - Part 7: Equipment protection by increased safety "e", reference IECEx certificate number IECEx UL 15.0128X.

North American Hazardous Location Approval

The following information applies when operating this equipment in hazardous locations.

Products marked "CL I, DIV 2, GP A, B, C, D" are suitable for use in Class I Division 2 Groups A, B, C, D, Hazardous Locations and nonhazardous locations only. Each product is supplied with markings on the rating nameplate indicating the hazardous location temperature code. When combining products within a system, the most adverse temperature code (lowest "T" number) may be used to help determine the overall temperature code of the system. Combinations of equipment in your system are subject to investigation by the local Authority Having Jurisdiction at the time of installation.

Informations sur l'utilisation de cet équipement en environnements dangereux.

Les produits marqués "CL I, DIV 2, GP A, B, C, D" ne conviennent qu'à une utilisation en environnements de Classe I Division 2 Groupes A, B, C, D dangereux et non dangereux. Chaque produit est livré avec des marquages sur sa plaque d'identification qui indiquent le code de température pour les environnements dangereux. Lorsque plusieurs produits sont combinés dans un système, le code de température le plus défavorable (code de température le plus faible) peut être utilisé pour déterminer le code de température global du système. Les combinaisons d'équipements dans le système sont sujettes à inspection par les autorités locales qualifiées au moment de l'installation.



WARNING: Explosion Hazard -

- Do not disconnect equipment unless power has been removed or the area is known to be nonhazardous.
- Do not disconnect connections to this equipment unless power has been removed or the area is known to be nonhazardous. Secure any external connections that mate to this equipment by using screws, sliding latches, threaded connectors, or other means provided with this product.
- Substitution of components may impair suitability for Class I Division 2.
- If this product contains batteries, they must only be changed in an area known to be nonhazardous.



AVERTISSEMENT: Risque d'Explosion -

- Couper le courant ou s'assurer que l'environnement est classé non dangereux avant de débrancher l'équipement.
- Couper le courant ou s'assurer que l'environnement est classé non dangereux avant de débrancher les connecteurs. Fixer tous les connecteurs externes reliés à cet équipement à l'aide de vis, loquets coulissants, connecteurs filetés ou autres moyens fournis avec ce produit.
- La substitution de composants peut rendre cet équipement inadapté à une utilisation en environnement de Classe I Division 2.
- S'assurer que l'environnement est classé non dangereux avant de changer les piles.



WARNING: When used in a Class I Division 2, hazardous location, this equipment must be mounted in a suitable enclosure with proper wiring method that complies with the governing electrical codes.



WARNING: If you connect or disconnect wiring while the field-side power is on, an electric arc can occur. This could cause an explosion in hazardous location installations. Be sure that power is removed or the area is nonhazardous before proceeding.



WARNING: For Class I Division 2 applications, use only Class I Division 2 listed or recognized accessories and modules approved for use within the FLEX™ I/O platform.

Install the Module

Read this for information about how to install the FLEX I/O-XT™ 8-input channel isolated HART analog module, which mounts on a 1794-TB3 or 1794-TB3S terminal base. This product can be used with FLEX I/O ControlNet® and EtherNet/IP™ adapters, using the Studio 5000 Logix Designer® application version 20 or later.

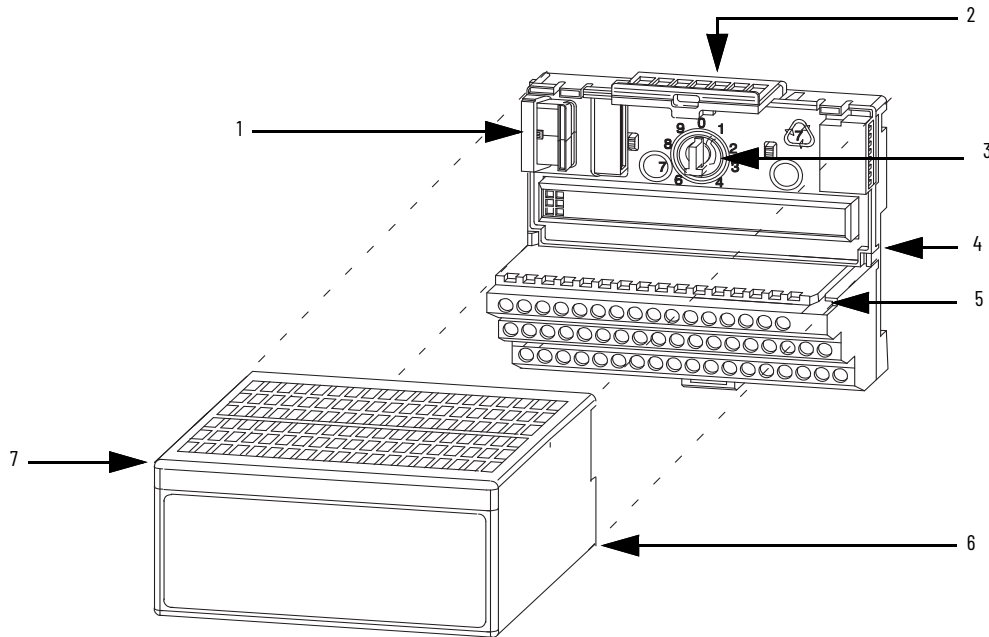

Module Description

	Description		Description
1	Flexbus connector	5	Groove
2	Latching mechanism	6	Alignment bar
3	Keyswitch	7	Module
4	Terminal base		



ATTENTION: During mounting of all devices, be sure that all debris (such as metal chips or wire strands) are kept from falling into the module. Debris that falls into the module could cause damage on power-up.

To install the module on a FLEX terminal base, see the figure and complete the following:

1. Rotate the keyswitch (3) on the terminal base (4) clockwise to position 3 as required for this type of module.
2. Verify that the Flexbus connector (1) is pushed all way to the left to connect with the neighboring terminal base or adapter. **You cannot install the module unless the connector is fully extended.**
3. Verify that the pins on the bottom of the module are straight so that they align properly with the connector in the terminal base.



WARNING: If you remove or insert the module while the backplane power is on, an electric arc can occur. This could cause an explosion in hazardous location installations. Be sure that power is removed or the area is nonhazardous before proceeding.

4. Position the module (7) with its alignment bar (6) aligned with the groove (5) on the terminal base.
5. Press firmly and evenly to seat the module in the terminal base unit. The module is seated when the latching mechanism (2) is locked into the module.

Wire the Module



WARNING: If you connect or disconnect wiring while the field-side power is on, an electric arc can occur. This could cause an explosion in hazardous location installations. Be sure that power is removed or the area is nonhazardous before proceeding.

To connect wiring for 1794-TB3 and 1794-TB3S bases, see the tables and figure and complete the following:

1. Connect individual input wiring to numbered terminals on the 0...15 row A, as indicated in [Table 1](#), using Belden 8761 cable for signal wiring.



ATTENTION: Connect only one current signal per channel.

2. Connect each channel signal return to the associated terminal on row A.
3. Connect the +V DC power lead to terminal 34 on the 34...51 row C, and the -V common/return to terminal 16 on the 16...33 row B.



ATTENTION: To reduce susceptibility to noise, power analog modules and digital modules from separate power supplies. Do not exceed a length of 3 m (9.8 ft) for DC power cabling.

4. If daisy chaining power to the next terminal base, connect a jumper from terminal 51 (+V DC) on this base unit to terminal 34 on the next base unit.
5. If continuing DC common to the next base unit, connect a jumper from terminal 33 (common) on this base unit to terminal 16 on the next base unit.
6. For both 1794-TB3 and 1794-TB3S bases, connect wiring shields to functional earth ground as near as possible to the module.

Ground the Module

All I/O wiring must use shielded wire. Shields must be terminated external to the module, such as busbars and shield-terminating feed-throughs.

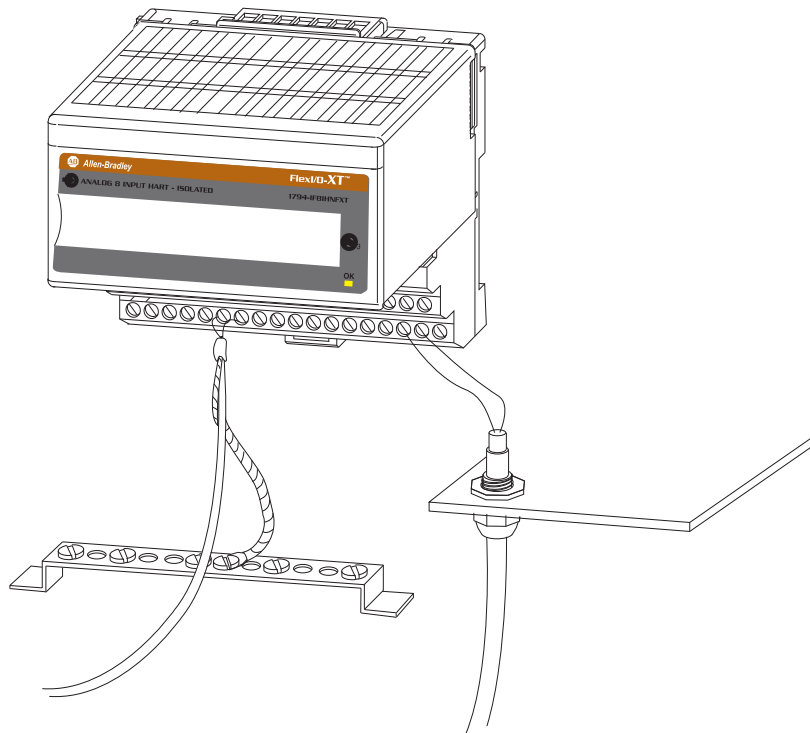

Module Wiring

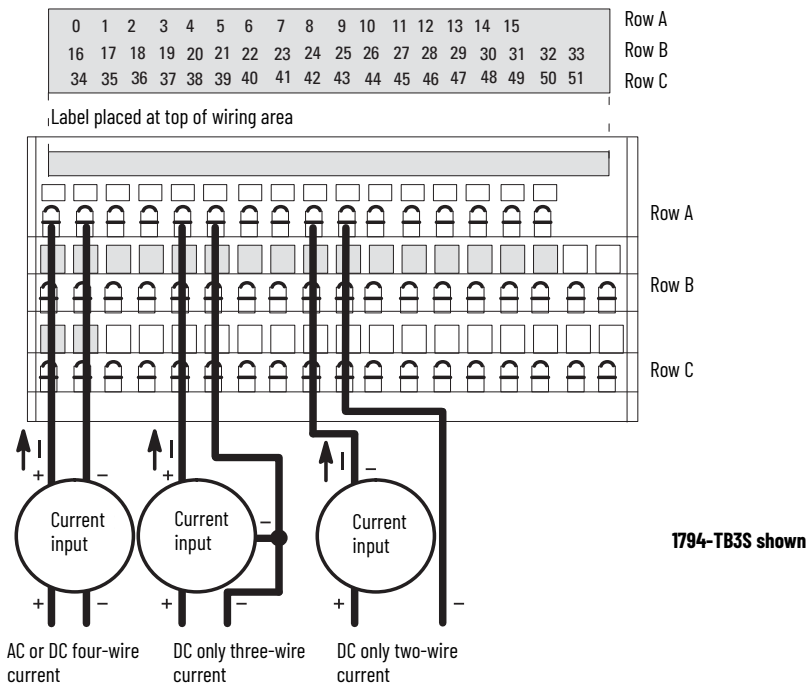

Table 1 - Wire Connections

Channel	Signal Type	Label Markings	Catalog Numbers 1794-TB3 or 1794-TB3S Terminal
0	Current	I0	A-0
	Current	I0 Ret	A-1
1	Current	I1	A-2
	Current	I1 Ret	A-3
2	Current	I2	A-4
	Current	I2 Ret	A-5
3	Current	I3	A-6
	Current	I3 Ret	A-7
4	Current	I4	A-8
	Current	I4 Ret	A-9
5	Current	I5	A-10
	Current	I5 Ret	A-11
6	Current	I6	A-12
	Current	I6 Ret	A-13
7	Current	I7	A-14
	Current	I7 Ret	A-15
-V DC	For catalog numbers 1794-TB3 and 1794-TB3S, terminals B-16...33 are internally connected in the terminal base unit.		
+V DC	For catalog numbers 1794-TB3 and 1794-TB3S, terminals C-34...51 are internally connected in the terminal base unit.		

Table 2 - Input Map

Word	Bit															
	15	14	13	12	11	10	9	8	7	6	5	4	3	2	1	0
0	Channel 0 Input Data															
1	Channel 1 Input Data															
2	Channel 2 Input Data															
3	Channel 3 Input Data															
4	Channel 4 Input Data															
5	Channel 5 Input Data															

Table 2 - Input Map (Continued)

Word	Bit															
	15	14	13	12	11	10	9	8	7	6	5	4	3	2	1	0
6	Channel 6 Input Data															
7	Channel 7 Input Data															
8	H7	H6	H5	H4	H3	H2	H1	H0	L7	L6	L5	L4	L3	L2	L1	L0
9	R7	R6	R5	R4	R3	R2	R1	R0	P7	P6	P5	P4	P3	P2	P1	P0
10	X7	X6	X5	X4	X3	X2	X1	X0	Diagnostic Status							
11	C7	C6	C5	C4	C3	C2	C1	C0	F7	F6	F5	F4	F3	F2	F1	F0
Hn:	Channel n High Alarm								0: False				1: True			
Ln:	Channel n Low Alarm								0: False				1: True			
Pn:	Channel n Out of Range Alarm								0: False				1: True			
Rn:	Channel n Second (Remote) Alarm								0: False				1: True			
Fn:	Channel n HART Failure								0: False				1: True			
Cn:	Channel n HART Current Fault								0: False				1: True			
Xn:	Channel n HART Transmitter Present								0: False				1: True			

Note: Reserved data may not be shown in certain controller software.

Table 3 - Output Map

Word	Bit															
	15	14	13	12	11	10	9	8	7	6	5	4	3	2	1	0
0	R	R	R	R	R	R	R	R	H07	H06	H05	H04	H03	H02	H01	H00

Where: H0n - HART Off Dynamic Control bit. 1: True; 0: False

Table 4 - Configuration Map

Word	Bit															
	15	14	13	12	11	10	9	8	7	6	5	4	3	2	1	0
0	R	R	F7	F6	F5	F4	BOB ⁽¹⁾		R	R	F3	F2	F1	F0	BOA ⁽¹⁾	
1	DH7	DH6	DH5	DH4	DH3	DH2	DH1	DH0	Reserved							
2	CH3 Format				CH2 Format				CH1 Format				CH0 Format			
3	CH7 Format				CH6 Format				CH5 Format				CH4 Format			
4	HART_lLimit_CH1					FLTR1			HART_lLimit_CH0					FLTR0		
5	HART_lLimit_CH3					FLTR3			HART_lLimit_CH2					FLTR2		
6	HART_lLimit_CH5					FLTR5			HART_lLimit_CH4					FLTR4		
7	HART_lLimit_CH7					FLTR7			HART_lLimit_CH6					FLTR6		
8	CH0 High Alarm Threshold															
9	CH0 Low Alarm Threshold															
10	CH0 Remote High High Alarm Limit															
11	CH0 Remote Low Low Alarm Limit															
12	CH0 PvDampingValue (32 bit, Floating Point, LowWord)															
13	CH0 PvDampingValue (32-bit Floating Point, HighWord)															
14	CH0 PvUpperRange (32-bit Floating Point, LowWord)															
15	CH0 PvUpperRange (32-bit Floating Point, HighWord)															
16	CH0 PvLowerRange (32-bit Floating Point, LowWord)															
17	CH0 PvLowerRange (32-bit Floating Point, HighWord)															
18	Reserved								CH0 PV Range Units Code							
19	Unused															
20...31	Words 8...19 for channel 1															
32...43	Words 8...19 for channel 2															
44...55	Words 8...19 for channel 3															
56...67	Words 8...19 for channel 4															
68...79	Words 8...19 for channel 5															
80...91	Words 8...19 for channel 5															
92...103	Words 8...19 for channel 5															
104	Reserved								C7	C6	C5	C4	C3	C2	C1	C0
105	ER7	ER6	ER5	ER4	ER3	ER2	ER1	ER0	ED7	ED6	ED5	ED4	ED3	ED2	ED1	ED0

(1) Not shown in Studio 5000 Logix Designer application.

Table 5 - Configuration Map Descriptions

Bit	Description	Value	
BOA BOB	Byte Order Group A Byte Order Group B	Byte order group A and B values must match each other. See Byte Order on page 9 .	
FLTRn	Channel n Digital Filter	See Channel Digital Filter on page 9 .	
Fn	Fault mode channel n	0: Local/Remote faults disabled	1: Enabled
CHn HART Current Ratio	HART current fault ratio limit on channel n	Valid values are 0, or 5...31 percent of full scale. A value of 0 disables this feature. See HART Current Ratio on page 9 for more information.	
HART_Llimit_CHn	HART Loop Tolerance Error Limit for channel n. Defines comparison limit for HART current loop to ADC compare.	Valid values are 0, or 5...31 percent of full scale. A value of zero disables this feature. Full-scale is defined as the difference between the normal high scale and the normal low. Example: 4...20 mA: 20...4 = 16. 5% of 16 is 0.8 mA. Example: 4...20 mA: 20...0 = 20. 5% of 20 is 1.0 mA.	
DHn	Disable HART communication on channel n	0: HART communications enabled	1: HART communications disabled
Cn	HART Data Publishing Disable	0: HART Data Publishing Disable enabled	1: HART Data Publishing Disable disabled
EDn	Enable HART PV Damping Value	0: True	1: False
ERn	Enable HART PV Upper and Lower Range	0: True	1: False
R	Reserved		
CH N Format	See Channel Data Formats on page 10 .		

Table 6 - Byte Order

Byte Order Group B		Byte Order Group A		Description
Bit 9	Bit 8	Bit 1	Bit 0	
0	0	0	0	Little-endian Format (default) - All data entries in true little-endian format.
1	0	1	0	Word Swap - Word swap only values requiring multiple word, for example, 32-bit float values.
0	1	0	1	Byte Swap - Byte swap all words in data table.
1	1	1	1	Big-endian Format - All data entries in true big-endian format.

Table 7 - Channel Digital Filter

Digital Filter Frequency	Decimal Value	Bit		
		10	9	8
		2	1	0
242 Hz	0	0	0	0
123 Hz	1	0	0	1
62 Hz	2	0	1	0
19.6 Hz	3	0	1	1
16.7 Hz	4	1	0	0
10 Hz	5	1	0	1
4.17 Hz	6	1	1	0
Not applicable	7	1	1	1

Table 8 - HART Current Ratio

HART Current Ratio Limit	Decimal Value	Bits				
		15	14	13	12	11
Disabled	0	0	0	0	0	0
Not applicable	1	0	0	0	0	1
Not applicable	2	0	0	0	1	0
Not applicable	3	0	0	0	1	1
Not applicable	4	0	0	1	0	0
5%	5	0	0	1	0	1
6%	6	0	0	1	1	0
7%	7	0	0	1	1	1
8%	8	0	1	0	0	0
9%	9	0	1	0	0	1
10%	10	0	1	0	1	0
...
30%	30	1	1	1	1	0
31%	31	1	1	1	1	1

Table 9 - Format Values

Format	Format name	0.0 mA	2.0 mA	4.0 mA	20.0 mA	21.0 mA	22.0 mA
0	0...20 mA in Milliamps	0	2000	4000	20000	21000	22000
1	0...20 mA in % Full Scale	0	1000	2000	10000	10500	11000
3	0...20 mA in UINT	0	6554	13107	65535	65535 ⁽²⁾	65535 ⁽²⁾
4	4...20 mA in Milliamps	2000 ⁽²⁾	2000	4000	20000	21000	22000
5	4...20 mA in % Full Scale	-1250 ⁽²⁾	-1250	0	10000	10625	11250
6	4...20 mA in Signed 2's Complement ⁽¹⁾	-7710	-3855	0	30840	32767	32767
7	4...20 mA in UINT	0 ⁽²⁾	0 ⁽²⁾	0	65535	65535 ⁽²⁾	65535 ⁽²⁾

(1) This 4...20 mA format continues to report values all way down to 0 mA. The other 4...20 mA formats stop reporting @ 2 mA (except for Binary that stops @ 4 mA).

(2) These values are under or over the supported user range, and are clamped at the lowest/highest supported values.

Table 10 - Channel Data Formats

Format ⁽¹⁾	Bits				Format Name	Signal Range		User Range		Resolution
	15	14	13	12		LO	HI	LO	HI	
0	0	0	0	0	0...20 mA in Milliamps	0.00	20.00	0	20000	1.0 µA
1	0	0	0	1	0...20 mA in % Full Scale	0.00	20.00	0	10000	2.0 µA
3	0	0	1	1	0...20 mA in UINT	0.00	20.00	0	65535	0.3052 µA
4	0	1	0	0	4...20 mA in Milliamps	4.00	20.00	4000	20000	1.0 µA
5	0	1	0	1	4...20 mA in % Full Scale	4.00	20.00	0	10000	1.6 µA
6	0	1	1	0	4...20 mA Signed 2's Complement	4.00	20.00	0	30840	0.5188 µA
7	0	1	1	1	4...20 mA in UINT	4.00	20.00	0	65535	0.2441 µA

(1) All other formats are invalid.

Cyclic HART Input Data

The HART input data holds the primary variables for the “live” HART device, and other information gathered during the normal HART scan. Additional “documentary” data is available through the pass through message interface in the device information tables. For detailed definitions of pass through messages, see the FLEX I/O Isolated Input/Output HART Analog Modules User Manual, publication [1794-UM065](#).

IMPORTANT

The HART Input Data for a channel may be zeros if HART communications are disabled for that channel. For more information on disabling HART communications, see Disable HART communications and HART Cmd 3 Disable functions in the [Configuration Map Descriptions on page 9](#)

Table 11 - HART Input Data

Word	Bit															
	15	14	13	12	11	10	9	8	7	6	5	4	3	2	1	0
0	Prepended by adapter, Cyclic Communication Status															
1	Prepended by adapter, Cyclic Communication Status															
2	CHO HART Field Device Status									CHO HART_COM_Status						
3	CHO PV Status									CHO HART Loop Status						
4	CHO HART Primary value (32-bit floating point)															
5	CHO HART Primary value (32-bit floating point)															
6	CHO HART Secondary value (32-bit floating point)															
7	CHO HART Secondary value (32-bit floating point)															
8	CHO Tertiary value (32-bit floating point)															
9	CHO Tertiary value (32-bit floating point)															
10	CHO Quaternary value (32-bit floating point)															
11	CHO Quaternary value (32-bit floating point)															
12	CHO SV Units									CHO PV Units						
13	CHO QV Units									CHO TV Units						
14...25	CH1 (Words 1...13)															
26...37	CH2 (Words 1...13)															
38...49	CH3 (Words 1...13)															
50...61	CH4 (Words 1...13)															
62...73	CH5 (Words 1...13)															
74...85	CH6 (Words 1...13)															
86	CH7 (Words 1...13)															

Table 12 - HART Input Data Descriptions

Cyclic Communication Status Bits 0...7 of Word 0	0: Disabled or No Communication Error between Adapter and Module	1: Communication Error between Adapter and Module
Chn: HART Comm Status (HART CMD3 Response first status byte):	See publication 1794-UM065	
Chn: HART Field Device Status (HART CMD3 Response second status byte):	See publication 1794-UM065	
Chn: HART Loop Status: Bit 0: HART enable Bit 1: Device Connected Bit 2: Response Error Bit 3: Cmd 48 Update Bit 4: HART Loop Tolerance Error Bit 5: HART Update	0: Disabled 0: Not Connected 0: No HART message failure 0: Cmd 48 not updated 0: No Mismatch 0: HART Device information not updated	1: Enabled 1: Connected 1: Response ended in error 1: Cmd 48 updated 1: Analog and HART Loop Values Mismatch 1: HART Device information updated since last read
Bit 6: HART message	0: No new message	1: HART user message queue has completed a message
Bit 7: PV Configuration Values Mismatch	0: No Mismatch	1: PV Damping/Range values mismatch
PV_Status: Bit 0: 01 - The primary variable for this channel has been acquired. Bit 1: 02 - The secondary variable for this channel has been acquired. Bit 2: 02 - The tertiary variable for this channel has been acquired. Bit 3: 02 - The quaternary variable for this channel has been acquired. Bit 4...7: Reserved		

Status Indicator

The OK status indicator is bicolor, red, and green. The indicator flashes green for these reasons:

- The module configuration word is zero (for example, power-up reset condition).
- The 24V DC user power is off.
- The module is in Configuration mode.

The indicator displays red to indicate that the module did not pass the initial hardware test. Recycle power in response to this display. After power-up, if the status indicator is not flashing green or steady green, recycle module power to verify a proper reset of the bus interface.

Specifications

General Specifications

Attribute	Value
Number of inputs	8 single-ended isolated
Recommended terminal base unit	1794-TB3, 1794-TB3S
Resolution	16 bits unipolar
Current	0.3052 µA/cnt unipolar; 0.6104 µA/cnt bipolar
Data format	Engineering units ⁽¹⁾ , Percent Full Scale, Proportional Count
Conversion type	Sigma Delta
Calibration required	Factory calibrated Can be calibrated in field when necessary.
Input current terminal	4...20 mA (configurable); 0...20 mA (configurable)
Normal mode rejection ratio	>70 dB @ 50/60 Hz with 4.17 Hz rate >65 dB @ 50/60 Hz with 10 Hz rate >75 dB @ 50 Hz with 16.7 Hz rate >70 dB @ 60 Hz with 19.6 Hz rate
Common mode rejection ratio	>60 dB @ 50 Hz and 60 Hz
Step response to 99% - current terminal	4.17 Hz conversion rate = 480 ms 10.0 Hz conversion rate = 200 ms 16.7 Hz conversion rate = 120 ms 19.6 Hz conversion rate = 101 ms 62 Hz conversion rate = 32 ms 123 Hz conversion rate = 17 ms 242 Hz conversion rate = 14 ms
Channel update time	240 ms - 4.17 Hz conversion rate 100 ms - 10 Hz conversion rate 60 ms - 19.6 Hz conversion rate 51 ms - 19.6 Hz conversion rate 16 ms - 62 Hz conversion rate 13 ms - 123 Hz conversion rate 9 ms - 242 Hz conversion rate
Analog filter frequency	78 Hz

General Specifications (Continued)

Attribute	Value
Input impedance	249 Ω ± 1%
Accuracy	±0.1% @ 25 °C (77 °F) - 4.17...62 Hz sample rates ±0.12% @ 25 °C (77 °F) - 123 Hz and 242 Hz, HART disabled ±0.75% @ 25 °C (77 °F) - 123 Hz and 242 Hz, HART enabled ±0.4% @ -25...+70 °C (-77...+158 °F) - 4.17...62 Hz sample rates ±0.42% @ -25...+70 °C (-77...+158 °F) - 123 Hz and 242 Hz, HART disabled ±1.05% @ -25...+70 °C (-77...+158 °F) - 123 Hz and 242 Hz, HART enabled
Absolute accuracy	0.1% Full scale @ 25 °C
Overload max	±32 mA continuous
Indicators	1 red/green power/status indicator
Isolation voltage	120V (continuous), Basic Insulation Type Type tested @ 1500V AC for 60 s, between channel to power, channel to system, power to system, and channel to channel
Power dissipation max	4.8 W @ 31.2V DC
Enclosure type rating	None (open-style)
Terminal base screw torque	Determined by installed terminal base
Wire size	Determined by installed terminal base
Wire type	Shielded on signal ports
Power input	80 mA @ 5V DC, Flexbus 190 mA @ 24V DC, Field power
Thermal dissipation max	16.4 BTU/hr @ 31.2V DC
Keyswitch position	3
External DC power supply voltage nom	24V DC
External DC power supply voltage range	19.2...31.2V DC (includes 5% AC ripple)
Ambient temperature	-25 °C ≤ T _{amb} ≤ +70 °C (-13 °F ≤ T _{amb} ≤ +158 °F)
North American temp code	T5
UKEX/ATEX temp code	T4
IECEX temp code	T4
Dimensions (HxWxD) approx	94.0 x 94.0 x 66.0 mm (3.7 x 3.7 x 2.6 in.) with module installed in base
Wiring category ⁽²⁾	1 - on signal ports 1 - on power ports

(1) Engineering units apply to HART data only.

(2) Use this Conductor Category information for planning conductor routing. See Industrial Automation Wiring and Grounding Guidelines, publication 1770-4.1.

Environmental Specifications

Attribute	Value
Temperature, operating	IEC 60068-2-1 (Test Ad, Operating Cold), IEC 60068-2-2 (Test Bd, Operating Dry Heat), IEC 60068-2-14 (Test Nb, Operating Thermal Shock): -25...+70 °C (-13...+158 °F)
Temperature, nonoperating	IEC 60068-2-1 (Test Ab, Unpackaged Nonoperating Cold), IEC 60068-2-2 (Test Bb, Unpackaged Nonoperating Dry Heat), IEC 60068-2-14 (Test Na, Unpackaged Nonoperating Thermal Shock): -40...+85 °C (-40...+185 °F)
Relative humidity	IEC 60068-2-30 (Test Db, Unpackaged Damp Heat) 5...95% noncondensing
Vibration	IEC 60068-2-6 (Test Fc, Operating): 5 g @ 10...500 Hz
Shock, operating	IEC 60068-2-27 (Test Ea, Unpackaged Shock): 30 g
Shock, nonoperating	IEC 60068-2-27 (Test Ea, Unpackaged Shock): 50 g
Emissions	IEC 61000-6-4
ESD immunity	IEC 61000-4-2: 6 kV contact discharges 8 kV air discharges
Radiated RF immunity	IEC 61000-4-3: 10V/m with 1 kHz sine wave 80% AM from 80...2000 MHz 10V/m with 200 Hz 50% Pulse 100% AM @ 900 MHz 10V/m with 200 Hz 50% Pulse 100% AM @ 1890 MHz 10V/m with 1 kHz sine wave 80% AM from 2000...2700 MHz

Environmental Specifications (Continued)

Attribute	Value
EFT/B immunity	IEC 61000-4-4: ±3 kV @ 5 kHz on power ports ±3 kV @ 5 kHz on signal ports
Surge transient immunity	IEC 61000-4-5: ±1 kV line-line(DM) and ±2 kV line-earth(CM) on power ports ±2 kV line-earth(CM) on shielded ports
Conducted RF immunity	IEC 61000-4-6: 10V rms with 1 kHz sine wave 80% AM from 150 kHz...80 MHz

Certifications

Certification (when product is marked) ⁽¹⁾	Value
c-UL-us	UL Listed Industrial Control Equipment, certified for US and Canada. See UL File E65584. UL Listed for Class I, Division 2 Group A,B,C,D Hazardous Locations, certified for U.S. and Canada. See UL File E194810.
CE and UKCA	UK Statutory Instrument 2016 No. 1091 and European Union 2014/30/EU EMC Directive, compliant with: EN 61326-1; Meas./Control/Lab., Industrial Requirements EN 61000-6-2; Industrial Immunity EN 61000-6-4; Industrial Emissions EN 61131-2; Programmable Controllers (Clause 8, Zone A & B) UK Statutory Instrument 2012 No. 3032 and European Union 2011/65/EU RoHS, compliant with: EN 63000; Technical documentation
 II 3 G	UK Statutory Instrument 2016 No. 1107 and European Union 2014/34/EU ATEX Directive, compliant with: EN 60079-7: Potentially Explosive Atmospheres, Protection EN 60079-0: General Requirements II 3 G Ex ec IIC T4 Gc UL 20 ATEX 2402X UL22UKEX2488X
IECEX	IECEX System, compliant with: IEC 60079-7: Potentially Explosive Atmospheres, Protection "e" IEC 60079-0: General Requirements Ex ec IIC T4 Gc IECEX UL 15.0128X
TÜV	TÜV Certified for Functional Safety ⁽²⁾ . Capable of SIL 2
Morocco	Arrêté ministériel n° 6404-15 du 29 ramadan 1436 - EMC
RCM	Australian Radiocommunications Act, compliant with: EN 61000-6-4; Industrial Emissions
CCC	CNCA-C23-01 强制性产品认证实施规则 防爆电气 CNCA-C23-01 CCC Implementation Rule Explosion-Proof Electrical Products CCC 2021122309113940

(1) See product certifications link at rok.auto/certifications for declarations of conformity, certificates, and other certification details.

(2) When used with specified firmware revisions.



ATTENTION: This device is listed only when used with listed Allen-Bradley® Catalog Number 1794-TB3 or 1794-TB3S terminal base. This device is intended for use with Allen-Bradley type FLEX I/O programmable controller system.



ATTENTION: To comply with UL restrictions, all connected I/O must be powered from a source compliant with the following: Isolated Secondary Limited Voltage, Class 2, or Limited Voltage/Current

Additional Resources

For more information on the products that are described in this publication, use these resources. You can view or download publications at rok.auto/literature.

Resource	Description
FLEX I/O and FLEX I/O-XT Selection Guide, publication 1794-SG002	Provides information on how to select FLEX I/O and FLEX I/O-XT adapters, terminal bases, I/O modules, and accessories.
FLEX I/O Isolated Input/Output HART Analog Modules User Manual, publication 1794-UM065	A detailed description of module functionality, configuration, and information on how to use the FLEX I/O isolated input/output HART analog modules.
Industrial Automation Wiring and Grounding Guidelines, publication 1770-4.1	More information on proper wiring and grounding techniques.
Product Certifications website, rok.auto/certifications	Provides declarations of conformity, certificates, and other certification details.

Notes:

Notes:

Rockwell Automation Support

Use these resources to access support information.

Technical Support Center	Find help with how-to videos, FAQs, chat, user forums, Knowledgebase, and product notification updates.	rok.auto/support
Local Technical Support Phone Numbers	Locate the telephone number for your country.	rok.auto/phonesupport
Technical Documentation Center	Quickly access and download technical specifications, installation instructions, and user manuals.	rok.auto/techdocs
Literature Library	Find installation instructions, manuals, brochures, and technical data publications.	rok.auto/literature
Product Compatibility and Download Center (PCDC)	Download firmware, associated files (such as AOP, EDS, and DTM), and access product release notes.	rok.auto/pcdc

Documentation Feedback

Your comments help us serve your documentation needs better. If you have any suggestions on how to improve our content, complete the form at rok.auto/docfeedback.





Waste Electrical and Electronic Equipment (WEEE)



At the end of life, this equipment should be collected separately from any unsorted municipal waste.

Rockwell Automation maintains current product environmental compliance information on its website at rok.auto/pec.

Rockwell Otomasyon Ticaret A.Ş. Kar Plaza İş Merkezi E Blok Kat:6 34752 İçerenköy, İstanbul, Tel: +90 (216) 5698400 EEE Yönetmeliğine Uygundur

Connect with us.    

rockwellautomation.com — expanding **human possibility**[®]

AMERICAS: Rockwell Automation, 1201 South Second Street, Milwaukee, WI 53204-2496 USA, Tel: (1) 414.382.2000

EUROPE/MIDDLE EAST/AFRICA: Rockwell Automation NV, Pegasus Park, De Kleetlaan 12a, 1831 Diegem, Belgium, Tel: (32) 2663 0600

ASIA PACIFIC: Rockwell Automation SEA Pte Ltd, 2 Corporation Road, #04-05, Main Lobby, Corporation Place, Singapore 618494, Tel: (65) 6510 6608

UNITED KINGDOM: Rockwell Automation Ltd., Pitfield, Kiln Farm, Milton Keynes, MK11 3DR, United Kingdom, Tel: (44)(1908) 838-800

Allen-Bradley, expanding human possibility, FactoryTalk, FLEX, FLEX I/O-XT, Rockwell Automation, Studio 5000 Logix Designer, and TechConnect are trademarks of Rockwell Automation, Inc.

ControlNet and EtherNet/IP are trademarks of ODVA, Inc.

Trademarks not belonging to Rockwell Automation are property of their respective companies.

Publication 1794-IN134G-EN-P - September 2025 | Supersedes Publication 1794-IN134F-EN-P - February 2024

Copyright © 2025 Rockwell Automation, Inc. All rights reserved. Printed in Mexico.

PN-747931