

Installation Instructions

Original Instructions



Allen-Bradley

by ROCKWELL AUTOMATION

FLEX I/O Input, Output, and Input/Output Analog Modules

Catalog Numbers 1794-IE8XT, 1794-OE4XT, 1794-IE4XOE2XT, Series B

Topic	Page
Summary of Changes	1
Overview	5
Install Your Module	5
Configure Your Module	9
Specifications	11
Additional Resources	13

Summary of Changes

This publication contains the following new or updated information. This list includes substantive updates only and is not intended to reflect all changes.

Topic	Page
Updated Certifications	13
Added Additional Resources	13



ATTENTION: Read this document and the documents listed in the Additional Resources section about installation, configuration and operation of this equipment before you install, configure, operate or maintain this product. Users are required to familiarize themselves with installation and wiring instructions in addition to requirements of all applicable codes, laws, and standards.

Activities including installation, adjustments, putting into service, use, assembly, disassembly, and maintenance are required to be carried out by suitably trained personnel in accordance with applicable code of practice. If this equipment is used in a manner not specified by the manufacturer, the protection provided by the equipment may be impaired.

注意：在安装、配置、操作和维护本产品前，请阅读本文档以及“其他资源”部分列出的有关设备安装、配置和操作的相应文档。除了所有适用规范、法律和标准的相关要求之外，用户还必须熟悉安装和接线说明。

安装、调整、投运、使用、组装、拆卸和维护等各项操作必须由经过适当训练的专业人员按照适用的操作规范实施。

如果未按照制造商指定的方式使用该设备，则可能会损害设备提供的保护。

ATENCIÓN: Antes de instalar, configurar, poner en funcionamiento o realizar el mantenimiento de este producto, lea este documento y los documentos listados en la sección Recursos adicionales acerca de la instalación, configuración y operación de este equipo. Los usuarios deben familiarizarse con las instrucciones de instalación y cableado y con los requisitos de todos los códigos, leyes y estándares vigentes.

El personal debidamente capacitado debe realizar las actividades relacionadas a la instalación, ajustes, puesta en servicio, uso, ensamblaje, desensamblaje y mantenimiento de conformidad con el código de práctica aplicable. Si este equipo se usa de una manera no especificada por el fabricante, la protección provista por el equipo puede resultar afectada.

ATENÇÃO: Leia este e os demais documentos sobre instalação, configuração e operação do equipamento que estão na seção Recursos adicionais antes de instalar, configurar, operar ou manter este produto. Os usuários devem se familiarizar com as instruções de instalação e fiação além das especificações para todos os códigos, leis e normas aplicáveis.

É necessário que as atividades, incluindo instalação, ajustes, colocação em serviço, utilização, montagem, desmontagem e manutenção sejam realizadas por pessoal qualificado e especializado, de acordo com o código de prática aplicável.

Caso este equipamento seja utilizado de maneira não estabelecida pelo fabricante, a proteção fornecida pelo equipamento pode ficar prejudicada.

ВНИМАНИЕ: Перед тем как устанавливать, настраивать, эксплуатировать или обслуживать данное оборудование, прочитайте этот документ и документы, перечисленные в разделе «Дополнительные ресурсы». В этих документах изложены сведения об установке, настройке и эксплуатации данного оборудования. Пользователи обязаны ознакомиться с инструкциями по установке и прокладке соединений, а также с требованиями всех применимых норм, законов и стандартов.

Все действия, включая установку, наладку, ввод в эксплуатацию, использование, сборку, разборку и техническое обслуживание, должны выполняться обученным персоналом в соответствии с применимыми нормами и правилами.

Если оборудование используется не предусмотренным производителем образом, защита оборудования может быть нарушена.

注意：本製品を設置、構成、稼働または保守する前に、本書および本機器の設置、設定、操作についての参考資料の該当箇所に記載されている文書に目を通してください。ユーザは、すべての該当する条例、法律、規格の要件に加えて、設置および配線の手順に習熟している必要があります。

設置調整、運転の開始、使用、組立て、解体、保守を含む諸作業は、該当する実施規則に従って訓練を受けた適切な作業員が実行する必要があります。

本機器が製造メーカーにより指定されていない方法で使用されている場合、機器により提供されている保護が損なわれる恐れがあります。

ACHTUNG: Lesen Sie dieses Dokument und die im Abschnitt „Weitere Informationen“ aufgeführten Dokumente, die Informationen zu Installation, Konfiguration und Bedienung dieses Produkts enthalten, bevor Sie dieses Produkt installieren, konfigurieren, bedienen oder warten. Anwender müssen sich neben den Bestimmungen aller anwendbaren Vorschriften, Gesetze und Normen zusätzlich mit den Installations- und Verdrahtungsanweisungen vertraut machen.

Arbeiten im Rahmen der Installation, Anpassung, Inbetriebnahme, Verwendung, Montage, Demontage oder Instandhaltung dürfen nur durch ausreichend geschulte Mitarbeiter und in Übereinstimmung mit den anwendbaren Ausführungsvorschriften vorgenommen werden.

Wenn das Gerät in einer Weise verwendet wird, die vom Hersteller nicht vorgesehen ist, kann die Schutzfunktion beeinträchtigt sein.

ATTENTION: Lisez ce document et les documents listés dans la section Ressources complémentaires relatifs à l'installation, la configuration et le fonctionnement de cet équipement avant d'installer, configurer, utiliser ou entretenir ce produit. Les utilisateurs doivent se familiariser avec les instructions d'installation et de câblage en plus des exigences relatives aux codes, lois et normes en vigueur.

Les activités relatives à l'installation, le réglage, la mise en service, l'utilisation, l'assemblage, le démontage et l'entretien doivent être réalisées par des personnes formées selon le code de pratique en vigueur.

Si cet équipement est utilisé d'une façon qui n'a pas été définie par le fabricant, la protection fournie par l'équipement peut être compromise.

주요: 본 제품 설치, 설정, 작동 또는 유지 보수가 하기 전에 본 문서를 포함하여 설치, 설정 및 작동에 관한 참고 자료 섹션의 문서들을 반드시 읽고 숙지하십시오. 사용자는 모든 관련 규정, 법규 및 표준에서 요구하는 사항에 대해 반드시 설치 및 배선 지침을 숙지해야 합니다.

설치, 조정, 가동, 사용, 조립, 분해, 유지보수 등 모든 작업은 관련 규정에 따라 적절한 교육을 받은 사용자를 통해서만 수행해야 합니다.

본 장비를 제조사가 명시하지 않은 방법으로 사용하면 장비의 보호 기능이 손상될 수 있습니다.

ATTENZIONE: Prima di installare, configurare ed utilizzare il prodotto, o effettuare interventi di manutenzione su di esso, leggere il presente documento ed i documenti elencati nella sezione "Altre risorse", riguardanti l'installazione, la configurazione ed il funzionamento dell'apparecchiatura. Gli utenti devono leggere e comprendere le istruzioni di installazione e cablaggio, oltre ai requisiti previsti dalle leggi, codici e standard applicabili.

Le attività come installazione, regolazioni, utilizzo, assemblaggio, disassemblaggio e manutenzione devono essere svolte da personale adeguatamente addestrato, nel rispetto delle procedure previste.

Qualora l'apparecchio venga utilizzato con modalità diverse da quanto previsto dal produttore, la sua funzione di protezione potrebbe venire compromessa.

DİKKAT: Bu ürünün kurulumu, yapılandırılması, işletilmesi veya bakımı öncesinde bu dokümanı ve bu ekipmanın kurulumu, yapılandırılması ve işletimi ile ilgili ilave Kaynaklar bölümünde yer listelenmiş dokümanları okuyun. Kullanıcılar yürürlükteki tüm yönetmelikler, yasalar ve standartların gereksinimlerine ek olarak kurulum ve kablolama talimatlarını da öğrenmek zorundadır. Kurulum, ayarlama, hizmete alma, kullanma, parçaları birleştirme, parçaları sökme ve bakım gibi aktiviteler sadece uygun eğitimleri almış kişiler tarafından yürürlükteki uygulamaya yönetmeliklerine uygun şekilde yapılabilir.

Bu ekipman üretici tarafından belirlenmiş amacın dışında kullanılırsa, ekipman tarafından sağlanan koruma bozulabilir.

注意事項：在安装、設定、操作或維護本产品前，請先閱讀此文件以及列於「其他資源」章節中有關安裝、設定與操作此設備的文件。使用者必須熟悉安裝和配線指示，並符合所有法規、法律和標準要求。

包括安裝、調整、交付使用、使用、組裝、拆卸和維護等動作都必須交由已經過適當訓練的人員進行，以符合適用的實作法規。

如果將設備用於非製造商指定的用途時，可能會造成設備所提供的保護功能受損。

POZOR: Než začnete instalovat, konfigurovat či provozovat tento výrobek nebo provádět jeho údržbu, přečtěte si tento dokument a dokumenty uvedené v části Dodatečné zdroje ohledně instalace, konfigurace a provozu tohoto zařízení. Uživatelé se musejí vedle požadavků všech relevantních vyhlášek, zákonů a norem nutně seznámit také s pokyny pro instalaci a elektrické zapojení.

Činnosti zahrnující instalaci, nastavení, uvedení do provozu, užívání, montáž, demontáž a údržbu musí vykonávat vhodně proškolený personál v souladu s příslušnými prováděcími předpisy. Pokud se toto zařízení používá způsobem neodpovídajícím specifikaci výrobce, může být narušena ochrana, kterou toto zařízení poskytuje.

UWAGA: Przed instalacją, konfiguracją, użytkowaniem lub konserwacją tego produktu należy przeczytać niniejszy dokument oraz wszystkie dokumenty wymienione w sekcji Dodatkowe źródła omawiające instalację, konfigurację i procedury użytkowania tego urządzenia. Użytkownicy mają obowiązek zapoznać się z instrukcjami dotyczącymi instalacji oraz oprzewodowania, jak również z obowiązującymi kodeksami, prawem i normami.

Działania obejmujące instalację, regulację, przekazanie do użytkowania, użytkowanie, montaż, demontaż oraz konserwację muszą być wykonywane przez odpowiednio przeszkolony personel zgodnie z obowiązującym kodeksem postępowania.

Jeśli urządzenie jest użytkowane w sposób inny niż określony przez producenta, zabezpieczenie zapewniane przez urządzenie może zostać ograniczone.

OBS! Läs detta dokument samt dokumentet, som står listat i avsnittet Övriga resurser, om installation, konfigurering och drift av denna utrustning innan du installerar, konfigurerar eller börjar använda eller utföra underhållsarbete på produkten. Användare måste bekanta sig med instruktioner för installation och kabeldragning, förutom krav enligt gällande koder, lagar och standarder.

Åtgärder som installation, justering, service, användning, montering, demontering och underhållsarbete måste utföras av personal med lämplig utbildning enligt lämpligt bruk.

Om denna utrustning används på ett sätt som inte anges av tillverkaren kan det hända att utrustningens skyddsanordningar försätts ur funktion.

LET OP: Lees dit document en de documenten die genoemd worden in de paragraaf Aanvullende informatie over de installatie, configuratie en bediening van deze apparatuur voordat u dit product installeert, configureert, bedient of onderhoudt. Gebruikers moeten zich vertrouwd maken met de installatie en de bedringsinstructies, naast de vereisten van alle toepasselijke regels, wetten en normen.

Activiteiten zoals het installeren, afstellen, in gebruik stellen, gebruiken, monteren, demonteren en het uitvoeren van onderhoud mogen uitsluitend worden uitgevoerd door hiervoor opgeleide personeel en in overeenstemming met de geldende praktijkregels.

Indien de apparatuur wordt gebruikt op een wijze die niet is gespecificeerd door de fabrikant, dan bestaat het gevaar dat de beveiliging van de apparatuur niet goed werkt.

Environment and Enclosure



ATTENTION: This equipment is intended for use in a Pollution Degree 2 industrial environment, in overvoltage Category II applications (as defined in EN/IEC 60664-1), at altitudes up to 2000 m (6562 ft) without derating. This equipment is not intended for use in residential environments and may not provide adequate protection to radio communication services in such environments.

This equipment is supplied as open-type equipment for indoor use. It must be mounted within an enclosure that is suitably designed for those specific environmental conditions that will be present and appropriately designed to prevent personal injury resulting from accessibility to live parts. The enclosure must have suitable flame-retardant properties to prevent or minimize the spread of flame, complying with a flame spread rating of 5VA or be approved for the application if nonmetallic. The interior of the enclosure must be accessible only by the use of a tool. Subsequent sections of this publication may contain more information regarding specific enclosure type ratings that are required to comply with certain product safety certifications.

In addition to this publication, see the following:

- Industrial Automation Wiring and Grounding Guidelines, publication [1770-4.1](#), for more installation requirements.
 - NEMA Standard 250 and EN/IEC 60529, as applicable, for explanations of the degrees of protection provided by enclosures.
-

Prevent Electrostatic Discharge



ATTENTION: This equipment is sensitive to electrostatic discharge, which can cause internal damage and affect normal operation. Follow these guidelines when you handle this equipment:

- Touch a grounded object to discharge potential static.
 - Wear an approved grounding wriststrap.
 - Do not touch connectors or pins on component boards.
 - Do not touch circuit components inside the equipment.
 - Use a static-safe workstation, if available.
 - Store the equipment in appropriate static-safe packaging when not in use.
-

UK and European Hazardous Location Approval

The following applies to products marked  II 3 G:

- Are Equipment Group II, Equipment Category 3, and comply with the Essential Health and Safety Requirements relating to the design and construction of such equipment given in Schedule 1 of UKEX and Annex II of EU Directive 2014/34/EU. See the UKEX and EU Declaration of Conformity at rok.auto/certifications for details.
 - The type of protection is Ex ec IIC T4 Gc according to EN IEC 60079-0:2018 and EN IEC 60079-7:2015+A1:2018.
 - Comply with standards EN IEC 60079-0:2018 and EN IEC 60079-7:2015+A1:2018 reference certificate number DEMKO 14 ATEX 1342501X and UL22UKEX2378X.
 - Are intended for use in areas in which explosive atmospheres caused by gases, vapors, mists, or air are unlikely to occur, or are likely to occur only infrequently and for short periods. Such locations correspond to Zone 2 classification according to UKEX regulation 2016 No. 1107 and ATEX directive 2014/34/EU.
-

IEC Hazardous Location Approval

The following applies to products with IECEx certification:

- Are intended for use in areas in which explosive atmospheres caused by gases, vapors, mists, or air are unlikely to occur, or are likely to occur only infrequently and for short periods. Such locations correspond to Zone 2 classification to IEC 60079-0.
 - The type of protection is Ex ec IIC T4 Gc according to IEC 60079-0 and IEC 60079-7.
 - Comply with Standards IEC 60079-0, Explosive atmospheres Part 0: Equipment - General requirements, Edition 7, Revision Date 2017, IEC 60079-7, 5.1 Edition revision date 2017, Explosive atmospheres - Part 7: Equipment protection by increased safety "e", reference IECEx certificate number IECEx UL 14.0066X.
-

WARNING: Special Conditions for Safe Use:

- This equipment shall be mounted in an UKEX/ATEX/IECEx Zone 2 certified enclosure with a minimum ingress protection rating of at least IP54 (in accordance with EN/IEC 60079-0) and used in an environment of not more than Pollution Degree 2 (as defined in EN/IEC 60664-1) when applied in Zone 2 environments. The enclosure must be accessible only by the use of a tool.
 - This equipment shall be used within its specified ratings defined by Rockwell Automation.
 - Transient protection shall be provided that is set at a level not exceeding 140% of the peak rated voltage value at the supply terminals to the equipment.
 - The instructions in the user manual shall be observed.
 - This equipment must be used only with UKEX/ATEX/IECEx certified Rockwell Automation backplanes.
 - Earthing is accomplished through mounting of modules on rail.
-





WARNING: Secure any external connections that mate to this equipment by using screws, sliding latches, threaded connectors, or other means provided with this product. Do not disconnect equipment unless power has been removed or the area is known to be nonhazardous.



WARNING: When you insert or remove the module while backplane power is on, an electric arc can occur. This could cause an explosion in hazardous location installations. Be sure that power is removed or the area is nonhazardous before proceeding. Repeated electric arcing causes excessive wear to contacts on both the module and its mating connector. Worn contacts may create electrical resistance that can affect module operation.

North American Hazardous Location Approval

The following information applies when operating this equipment in hazardous locations.	Informations sur l'utilisation de cet équipement en environnements dangereux.
<p>Products marked "CL I, DIV 2, GP A, B, C, D" are suitable for use in Class I Division 2 Groups A, B, C, D, Hazardous Locations and nonhazardous locations only. Each product is supplied with markings on the rating nameplate indicating the hazardous location temperature code. When combining products within a system, the most adverse temperature code (lowest "T" number) may be used to help determine the overall temperature code of the system. Combinations of equipment in your system are subject to investigation by the local Authority Having Jurisdiction at the time of installation.</p>	<p>Les produits marqués "CL I, DIV 2, GP A, B, C, D" ne conviennent qu'à une utilisation en environnements de Classe I Division 2 Groupes A, B, C, D dangereux et non dangereux. Chaque produit est livré avec des marquages sur sa plaque d'identification qui indiquent le code de température pour les environnements dangereux. Lorsque plusieurs produits sont combinés dans un système, le code de température le plus défavorable (code de température le plus faible) peut être utilisé pour déterminer le code de température global du système. Les combinaisons d'équipements dans le système sont sujettes à inspection par les autorités locales qualifiées au moment de l'installation.</p>
 <p>WARNING: Explosion Hazard -</p> <ul style="list-style-type: none"> Do not disconnect equipment unless power has been removed or the area is known to be nonhazardous. Do not disconnect connections to this equipment unless power has been removed or the area is known to be nonhazardous. Secure any external connections that mate to this equipment by using screws, sliding latches, threaded connectors, or other means provided with this product. Substitution of components may impair suitability for Class I Division 2. 	 <p>AVERTISSEMENT: Risque d'Explosion -</p> <ul style="list-style-type: none"> Couper le courant ou s'assurer que l'environnement est classé non dangereux avant de débrancher l'équipement. Couper le courant ou s'assurer que l'environnement est classé non dangereux avant de débrancher les connecteurs. Fixer tous les connecteurs externes reliés à cet équipement à l'aide de vis, loquets coulissants, connecteurs filetés ou autres moyens fournis avec ce produit. La substitution de composants peut rendre cet équipement inadapté à une utilisation en environnement de Classe I Division 2.



ATTENTION:

- If this equipment is used in a manner not specified by the manufacturer, the protection provided by the equipment may be impaired.
- Read this document and the documents listed in the Additional Resources section about installation, configuration, and operation of this equipment before you install, configure, operate, or maintain this product. Users are required to familiarize themselves with installation and wiring instructions in addition to requirements of all applicable codes, laws, and standards.
- Installation, adjustments, putting into service, use, assembly, disassembly, and maintenance are required to be carried out by suitably trained personnel in accordance with applicable code of practice.
- In case of malfunction or damage, no attempts at repair should be made. The module should be returned to the manufacturer for repair. Do not dismantle the module.
- Use only a soft dry anti-static cloth to wipe down equipment. Do not use any cleaning agents.



ATTENTION: This product is grounded through the DIN rail to chassis ground. Use zinc-plated chromate-passivated steel DIN rail to assure proper grounding. The use of other DIN rail materials (for example, aluminum or plastic) that can corrode, oxidize, or are poor conductors, can result in improper or intermittent grounding. Secure DIN rail to mounting surface approximately every 200 mm (7.8 in.) and use end-anchors appropriately. Be sure to ground the DIN rail properly. See the Industrial Automation Wiring and Grounding Guidelines, Rockwell Automation publication [1770-4.1](#), for more information.



ATTENTION: Personnel responsible for the application of safety-related Programmable Electronic Systems (PES) shall be aware of the safety requirements in the application of the system and shall be trained in using the system.



ATTENTION: Do not remove or replace a terminal base unit while power is applied. Interruption of the backplane can result in unintentional operation or machine motion.



ATTENTION: If you connect or disconnect wiring while the field-side power is on, an electric arc can occur. This could cause an explosion in hazardous location installations. Be sure that power is removed or the area is nonhazardous before proceeding.

Overview

The FLEX™ I/O module mounts on a FLEX I/O terminal base.

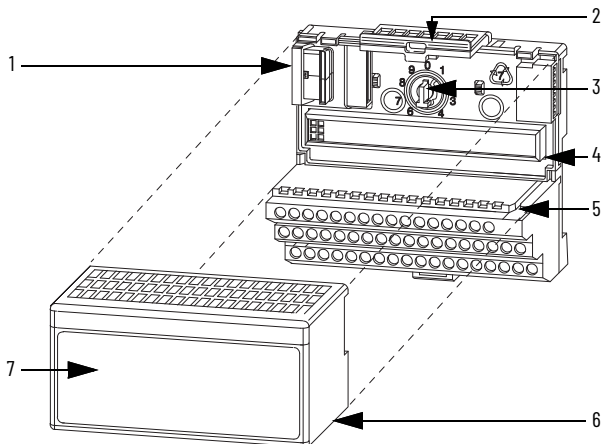

	Description		Description
1	Flexbus connector	5	Groove
2	Latching mechanism	6	Alignment bar
3	Keyswitch	7	Module
4	Terminal base		

Install Your Module



ATTENTION: During mounting of all devices, be sure that all debris (for example, metal chips, wire strands, and so on) is kept from falling into the module. Debris that falls into the module could cause damage on power up.



ATTENTION: Allow 25.4 mm (1 in.) of space between adjacent equipment for adequate ventilation.

1. Rotate the keyswitch (3) on the terminal base (4) clockwise to position 3 (1794-IE8XT), 4 (1794-OE4XT), or 5 (1794-IE4X0E2XT) as required.
2. Make sure the Flexbus connector (1) is pushed all the way to the left to connect with the adjacent terminal base or adapter. **You cannot install the module unless the connector is fully extended.**
3. Make sure that the pins on the bottom of the module are straight so that they align properly with the connector in the terminal base.
4. Position the module (7) with its alignment bar (6) aligned with the groove (5) on the terminal base.
5. Press firmly and evenly to seat the module in the terminal base unit. The module is seated when the latching mechanism (2) is locked into the module.

Connect Wiring for the Analog Inputs and Outputs

1. Connect individual input/output wiring to numbered terminals on the 0...15 row (A) for 1794-TB2, 1794-TB3, 1794-TB3S, 1794-TB3T, and 1794-TB3TS, or on row (B) for the 1794-TBN as indicated in [Table 1](#), [Table 2](#), and [Table 3](#).

IMPORTANT Use shielded wire for signal wiring.

2. Connect channel common/return to the associated terminal on row (A) or row (B) for the 1794-TB2, 1794-TB3, 1794-TB3S, 1794-TB3T, and 1794-TB3TS, or on row (C) for the 1794-TBN. For input devices requiring terminal base power, connect the channel power wiring to the associated terminal on row (C).
3. Connect any signal wiring shields to functional ground as near as possible to the module.
For 1794-TB3T or 1794-TB3TS only – Connect to earth ground terminals C-39...C-46.
4. Connect the +V DC power to terminal 34 on the 34...51 row (C) and -V common/return to terminal 16 on row (B).
5. If daisy chaining +V power to the next terminal base, connect a jumper from terminal 51 (+V DC) on this base unit to terminal 34 on the next base unit.
6. If continuing DC common (-V) to the next terminal base, connect a jumper from terminal 33 (common) on this base unit to terminal 16 on the next base unit.

Figure 1 - Terminal Base Wiring for the 1794-IE8XT Module

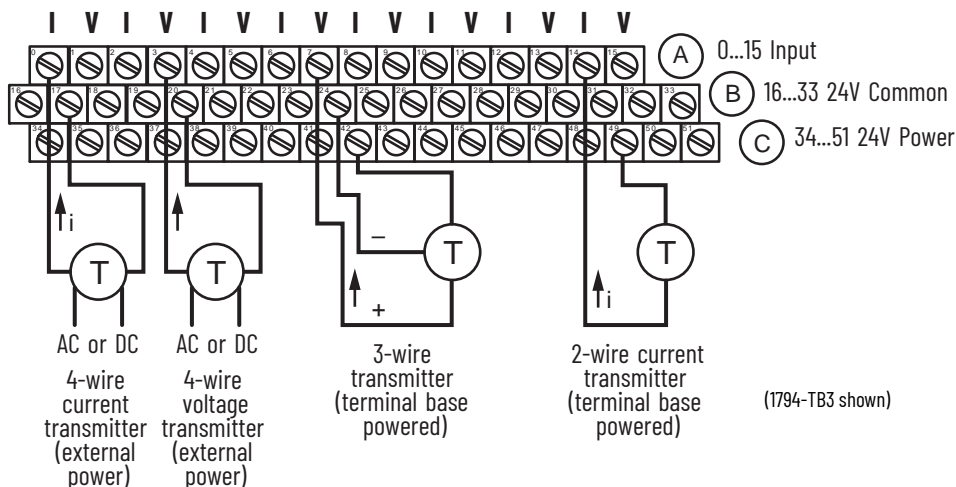

Table 1 - Wiring Connections for the 1794-IE8XT Module

Channel	Signal Type	Label Marking	1794-TB2, 1794-TB3, 1794-TB3S, 1794-TB3T, 1794-TB3TS	1794-TB3, 1794-TB3S	1794-TB2, 1794-TB3, 1794-TB3S	1794-TB3T, 1794-TB3TS	
			Input	Power ⁽¹⁾	Common Terminal		Shield
Input 0	Current	I0	A-0	C-35	B-17	B-17	C-39
	Voltage	V0	A-1	C-36	B-18	B-17	
Input 1	Current	I1	A-2	C-37	B-19	B-19	C-40
	Voltage	V1	A-3	C-38	B-20	B-19	
Input 2	Current	I2	A-4	C-39	B-21	B-21	C-41
	Voltage	V2	A-5	C-40	B-22	B-21	
Input 3	Current	I3	A-6	C-41	B-23	B-23	C-42
	Voltage	V3	A-7	C-42	B-24	B-23	
Input 4	Current	I4	A-8	C-43	B-25	B-25	C-43
	Voltage	V4	A-9	C-44	B-26	B-25	
Input 5	Current	I5	A-10	C-45	B-27	B-27	C-44
	Voltage	V5	A-11	C-46	B-28	B-27	
Input 6	Current	I6	A-12	C-47	B-29	B-29	C-45
	Voltage	V6	A-13	C-48	B-30	B-29	
Input 7	Current	I7	A-14	C-49	B-31	B-31	C-46
	Voltage	V7	A-15	C-50	B-32	B-31	
-V DC Common	1794-TB2, 1794-TB3, and 1794-TB3S - Terminals 16...33 are internally connected in the terminal base unit. 1794-TB3T and 1794-TB3TS - Terminals 16, 17, 19, 21, 23, 25, 27, 29, 31, and 33 are internally connected in the terminal base unit.						
+V DC Power	1794-TB3 and 1794-TB3S - Terminals 34...51 are internally connected in the terminal base unit. 1794-TB3T and 1794-TB3TS - Terminals 34, 35, 50, and 51 are internally connected in the terminal base unit. 1794-TB2 - Terminals 34 and 51 are internally connected in the terminal base unit.						
Chassis ground (Shield)	1794-TB3T and 1794-TB3TS - Terminals 39...46 are internally connected to chassis ground.						

(1) Use when transmitter requires terminal base power.

Figure 2 - Terminal Base Wiring for the 1794-OE4XT Module

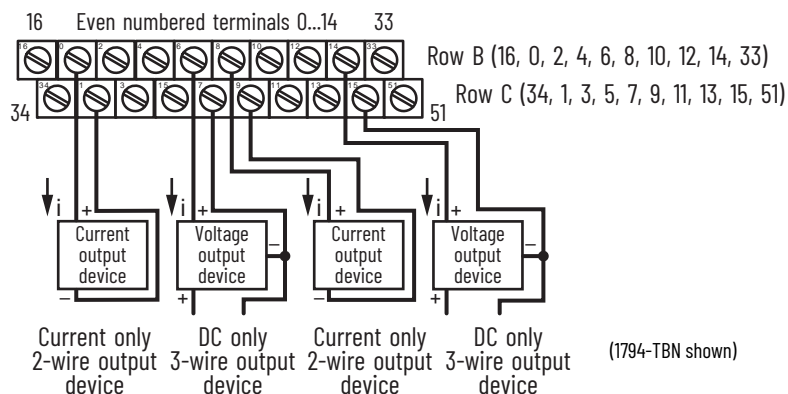

Table 2 - Wiring Connections for the 1794-OE4XT Module

Channel	Signal Type	Label Marking	1794-TB2, 1794-TB3, 1794-TB3S, 1794-TB3T, 1794-TB3TS		1794-TBN
			Output Terminal ⁽¹⁾	Shield (1794-TB3T, 1794-TB3TS)	Output Terminal ⁽²⁾
Output 0	Current	I0	A-0	C-39	B-0
	Current	I0 Ret	A-1		C-1
	Voltage	V0	A-2		B-2
	Voltage	V0 Ret	A-3		C-3
Output 1	Current	I1	A-4	C-41	B-4
	Current	I1 Ret	A-5		C-5
	Voltage	V1	A-6		B-6
	Voltage	V1 Ret	A-7		C-7
Output 2	Current	I2	A-8	C-43	B-8
	Current	I2 Ret	A-9		C-9
	Voltage	V2	A-10		B-10
	Voltage	V2 Ret	A-11		C-11
Output 3	Current	I3	A-12	C-45	B-12
	Current	I3 Ret	A-13		C-13
	Voltage	V3	A-14		B-14
	Voltage	V3 Ret	A-15		C-15
-V DC Common	1794-TB3 and 1794-TB3S - Terminals 16...33 are internally connected in the terminal base unit. 1794-TB3T and 1794-TB3TS - Terminals 16, 17, 19, 21, 23, 25, 27, 29, 31, and 33 are internally connected in the terminal base unit. 1794-TB2 - Terminals 16 and 33 are internally connected in the terminal base unit.				
+V DC Power	1794-TB3 and 1794-TB3S - Terminals 34...51 are internally connected in the terminal base unit. 1794-TB3T and 1794-TB3TS - Terminals 34, 35, 50, and 51 are internally connected in the terminal base unit. 1794-TB2 - Terminals 34 and 51 are internally connected in the terminal base unit.				
Chassis ground (Shield)	1794-TB3T, 1794-TB3TS - Terminals 39...46 are internally connected to chassis ground.				

(1) A-1, 3, 5, 7, 9, 11, 13, and 15 are internally connected in the module to 24V DC common.

(2) C-1, 3, 5, 7, 9, 11, 13, and 15 are internally connected in the module to 24V DC common.

Figure 3 - Terminal Base Wiring for the 1794-IE4XOE2XT Module

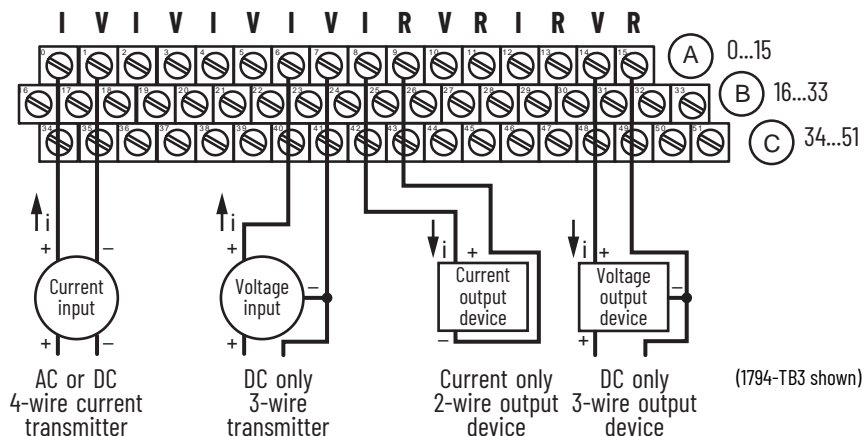

Table 3 - Wiring Connections for the 1794-IE4XOE2XT Module

Channel	Signal Type	Label Marking	1794-TB2, 1794-TB3, 1794-TB3S, 1794-TB3T, 1794-TB3TS	1794-TB3, 1794-TB3S	1794-TB2, 1794-TB3, 1794-TB3S	1794-TB3T, 1794-TB3TS	Shield			
			Input/Output Terminal ⁽¹⁾	Power Terminal ⁽²⁾	Common Terminal					
Input 0	Current	I0	A-0	C-35	B-17	B-17	C-39			
	Voltage	V0	A-1	C-36	B-18	B-17				
Input 1	Current	I1	A-2	C-37	B-19	B-19	C-40			
	Voltage	V1	A-3	C-38	B-20	B-19				
Input 2	Current	I2	A-4	C-39	B-21	B-21	C-41			
	Voltage	V2	A-5	C-40	B-22	B-21				
Input 3	Current	I3	A-6	C-41	B-23	B-23	C-42			
	Voltage	V3	A-7	C-42	B-24	B-23				
Output 0	Current	I0	A-8				C-43			
	Current	RET	A-9							
	Voltage	V0	A-10				C-44			
	Voltage	RET	A-11							
Output 1	Current	I1	A-12				C-45			
	Current	RET	A-13							
	Voltage	V1	A-14				C-46			
	Voltage	RET	A-15							
-V DC Common	1794-TB2, 1794-TB3, and 1794-TB3S - Terminals 16...33 are internally connected in the terminal base unit. 1794-TB3T and 1794-TB3TS - Terminals 16, 17, 19, 21, 23, 25, 27, 29, 31, and 33 are internally connected in the terminal base unit.									
+V DC Power	1794-TB3 and 1794-TB3S - Terminals 34...51 are internally connected in the terminal base unit. 1794-TB3T and 1794-TB3TS - Terminals 34, 35, 50, and 51 are internally connected in the terminal base unit. 1794-TB2 - Terminals 34 and 51 are internally connected in the terminal base unit.									
Chassis ground (Shield)	1794-TB3T and 1794-TB3TS - Terminals 39...46 are internally connected to chassis ground.									

(1) A-9, I1, I3 and I5 are internally connected in the module to 24V DC common.

(2) Use when the transmitter requires terminal base power.

Configure Your Module

Configure your input/output module by setting bits in the configuration word.

Table 4 - Input Map (Read) - 1794-IE8XT

Dec	15	14	13	12	11	10	9	8	7	6	5	4	3	2	1	0
Oct	17	16	15	14	13	12	11	10	7	6	5	4	3	2	1	0
Word 0	S	Analog input value for Channel 0														
Word 1	S	Analog input value for Channel 1														
Word 2	S	Analog input value for Channel 2														
Word 3	S	Analog input value for Channel 3														
Word 4	S	Analog input value for Channel 4														
Word 5	S	Analog input value for Channel 5														
Word 6	S	Analog input value for Channel 6														
Word 7	S	Analog input value for Channel 7														
Word 8	PU	Not used - Set to zero							U7	U6	U5	U4	U3	U2	U1	U0
Where:	PU = Power up in configuration S = Sign bit in 2's complement U = Underrange for specified channel															

Table 5 - Output Map (Write) - 1794-IE8XT

Dec	15	14	13	12	11	10	9	8	7	6	5	4	3	2	1	0
Oct	17	16	15	14	13	12	11	10	7	6	5	4	3	2	1	0
Word 3	C7	C6	C5	C4	C3	C2	C1	C0	F7	F6	F5	F4	F3	F2	F1	F0
Where:	C = Configure select bit F = Full range bit															

Table 6 - Input Map (Read) - 1794-IE4X0E2XT

Dec	15	14	13	12	11	10	9	8	7	6	5	4	3	2	1	0
Oct	17	16	15	14	13	12	11	10	7	6	5	4	3	2	1	0
Word 0	S	Analog input value for Channel 0														
Word 1	S	Analog input value for Channel 1														
Word 2	S	Analog input value for Channel 2														
Word 3	S	Analog input value for Channel 3														
Word 4	PU	Not used - Set to zero							W1	W0	U3	U2	U1	U0		
Where:	PU = Power up in configuration S = Sign bit in 2's complement W1 and W0 = Diagnostic bits for current output. Wire off current loop status for output channels 0 and 1. U = Underrange for specified channel															

Table 7 - Output Map (Write) - 1794-IE4X0E2XT

Dec	15	14	13	12	11	10	9	8	7	6	5	4	3	2	1	0
Oct	17	16	15	14	13	12	11	10	7	6	5	4	3	2	1	0
Word 0	S	Analog output data - Channel 0														
Word 1	S	Analog output data - Channel 1														
Word 2	Not used - Set to 0															
Word 3	0	0	C5	C4	C3	C2	C1	C0	0	0	F5	F4	F3	F2	F1	F0
Words 4 and 5	Not used - Set to 0															
Word 6	—	Safe state value for Channel 0														
Word 7	—	Safe state value for Channel 1														
Where:	PU = Power up in configuration CF = In configuration mode DN = Calibration accepted U = Underrange for specified channel PO and P1 = Outputs holding in response to Q0 and Q1 FP = Field power off BD = Bad calibration W1 and W0 = Wire off current loop status for output channels 0 and 1 V = Overrange for specified channel															

Table 8 - Range Selection Bits - 1794-IE8XT and 1794-IE4X0E2XT

1794-IE8XT	In Ch 0		In Ch 1		In Ch 2		In Ch 3		In Ch 4		In Ch 5		In Ch 6		In Ch 7	
1794-IE4X0E2XT	In Ch 0		In Ch 1		In Ch 2		In Ch 3		Out Ch 0		Out Ch 1					
	F0	C0	F1	C1	F2	C2	F3	C3	F4	C4	F5	C5	F6	C6	F7	C7
Dec Bits	00	08	01	09	02	10	03	11	04	12	05	13	06	14	07	15
0...10V DC or 0...20 mA	1	0	1	0	1	0	1	0	1	0	1	0	1	0	1	0
4...20 mA	0	1	0	1	0	1	0	1	0	1	0	1	0	1	0	1
-10...+10V DC	1	1	1	1	1	1	1	1	1	1	1	1	1	1	1	1
Off ⁽¹⁾	0	0	0	0	0	0	0	0	0	0	0	0	0	0	0	0
Where:	C = Configure select bit F = Full range															

(1) When configured to Off, individual input channels return 0000H; Output channels drive 0V/0 mA.

Table 9 - Input Map (Read) - 1794-0E4XT

Dec	15	14	13	12	11	10	9	8	7	6	5	4	3	2	1	0
Oct	17	16	15	14	13	12	11	10	7	6	5	4	3	2	1	0
Word 0	PU	Not used - Set to 0											W3	W2	W1	W0
Where:	PU = Power up bit W0...W3 = Wire off current loop status for output channels															

Table 10 - Output Map (Write) - 1794-0E4XT

Dec	15	14	13	12	11	10	9	8	7	6	5	4	3	2	1	0
Oct	17	16	15	14	13	12	11	10	7	6	5	4	3	2	1	0
Word 0	S	Output data Channel 0														
Word 1	S	Output data Channel 1														
Word 2	S	Output data Channel 2														
Word 3	S	Output data Channel 3														
Word 4	—	Not used - Set to 0											M3	M2	M1	M0
Word 5	Not used - Set to 0				C3	C2	C1	C0	Not used - Set to 0				F3	F2	F1	F0
Word 6...9	Not used - Set to 0															
Word 10	S	Safe state value for Channel 0														
Word 11	S	Safe state value for Channel 1														
Word 12	S	Safe state value for Channel 2														
Word 13	S	Safe state value for Channel 3														
Where:	S = Sign bit in 2's complement M = Multiplex control bit C = Configure select bit F = Full range bit															

Table 11 - Range Selection Bits - 1794-0E4XT

Channel Number	In Ch 0		In Ch 1		In Ch 2		In Ch 3	
	F0	C0	F1	C1	F2	C2	F3	C3
Dec Bits	00	08	01	09	02	10	03	11
0...10V DC or 0...20 mA	1	0	1	0	1	0	1	0
4...20 mA	0	1	0	1	0	1	0	1
-10...+10V DC	1	1	1	1	1	1	1	1
Off ⁽¹⁾	0	0	0	0	0	0	0	0
Where:	C = Configure select bit F = Full range							

(1) When configured to Off, individual output channels drive 0V/0 mA.

Specifications

Input Specifications

Attribute	Value
Number of inputs, single-ended, nonisolated	8 - 1794-IE8XT 4 - 1794-IE4XOE2XT
Resolution	12 bits unipolar; 11 bits plus sign bipolar Voltage: 2.56 mV/cnt unipolar; 5.13 mV/cnt bipolar Current: 5.13 μ A/cnt
Data format	Left justified, 16 bit 2's complement
Conversion type	Successive approximation
Conversion rate	256 μ s all channels
Input current terminal, user configurable	4...20 mA 0...20 mA, limited to 150VA
Input voltage terminal, user configurable	\pm 10V 0...10V, limited to 150VA
Normal mode rejection ratio	Voltage terminal: 3 dB @ 17 Hz; -20 dB/decade -10 dB @ 50 Hz; -11.4 dB @ 60 Hz Current terminal: -3 dB @ 9 Hz; -20 dB/decade -15.3 dB @ 50 Hz; -16.8 dB @ 60 Hz
Step response to 63%	Voltage terminal: 9.4 ms Current terminal: 18.2 ms
Input impedance	Voltage terminal: 100 k Ω Current terminal: 238 Ω
Input resistance voltage	Voltage terminal: 200 k Ω Current terminal: 238 Ω
Absolute accuracy ⁽¹⁾	0.20% full-scale @ 25 °C (77 °F)
Accuracy drift with temperature	Voltage terminal: 0.00428% full-scale/°C Current terminal: 0.00407% full-scale/°C
Calibration required	None required
Maximum overload	30V continuous or 32 mA continuous, one channel at a time
Indicators	1 green power indicator

(1) Includes offset, gain, nonlinearity, and repeatability error terms

Output Specifications

Attribute	Value
Number of outputs, single-ended, nonisolated	4 - 1794-OE4XT 2 - 1794-IE4XOE2XT
Resolution	12 bits plus sign Voltage: 0.156 mV/cnt Current: 0.320 μ A/cnt
Data format	Left justified, 16 bit 2's complement
Conversion type	Pulse-width modulation
Output current terminal, user configurable	0 mA output until module is configured 4...20 mA 0...20 mA
Output voltage terminal, user configurable	0V output until module is configured \pm 10V 0...10V
Step response to 63% - Voltage or current terminal	24 ms
Current load on voltage output, max	3 mA
Absolute accuracy ⁽¹⁾	Voltage terminal: 0.133% full-scale @ 25 °C (77 °F) Current terminal: 0.425% full-scale @ 25 °C (77 °F)
Accuracy drift with temperature	Voltage terminal: 0.0045% full-scale/°C Current terminal: 0.0069% full-scale/°C
Resistive load on mA output	15...750 Ω @ 24V DC

(1) Includes offset, gain, nonlinearity, and repeatability error terms

General Specifications

Attribute	Value
Recommended terminal base unit	1794-TB2, 1794-TB3, 1794-TB3S, 1794-TB3T, and 1794-TB3TS terminal base units - 1794-IE8XT, 1794-IE4XOE2XT 1794-TB2, 1794-TB3, 1794-TB3S, 1794-TB3T, 1794-TB3TS, and 1794-TBN terminal base units - 1794-0E4XT
Terminal base screw torque	Determined by the installed terminal base
Keyswitch position	3 - 1794-IE8XT 4 - 1794-0E4XT 5 - 1794-IE4XOE2XT
Isolation voltage	For 1794-IE8XT, 1794-IE4XOE2XT 50V (Continuous), Basic Insulation Type Type tested at 1000V AC for 60 s, between field side and system No isolation between individual channels For 1794-0E4XT 50V (Continuous), Basic Insulation Type Type tested at 850V DC for 60 s, between field side and system No isolation between individual channels
External DC power supply voltage, nom	24V DC
External DC power supply voltage range	10.5...31.2V DC (includes 5% AC ripple)
External DC power supply current	140 mA @ 24V DC - 1794-IE8XT 165 mA @ 24V DC - 1794-0E4XT 180 mA @ 24V DC - 1794-IE4XOE2XT
Flexbus current @ 5V DC	11 mA - 1794-IE8XT 15 mA - 1794-0E4XT, 1794-IE4XOE2XT
Power dissipation, max	3.0 W @ 31.2V DC - 1794-IE8XT 4.5 W @ 31.2V DC - 1794-0E4XT 4.0 W @ 31.2V DC - 1794-IE4XOE2XT
Thermal dissipation, max	10.2 BTU/hr @ 31.2V DC - 1794-IE8XT 13.6 BTU/hr @ 31.2V DC - 1794-0E4XT 15.3 BTU/hr @ 31.2V DC - 1794-IE4XOE2XT
Wire category ⁽¹⁾	2 - on signal ports
Wire size	Determined by the installed terminal base
Wire type	Shielded
Dimensions, approx. (H x W x D) (with module installed)	45.7 x 94 x 53.3 mm (1.8 x 3.7 x 2.1 in.)
Enclosure type rating	None (open-style)
North American temp code	T4A - 1794-IE8XT T3C - 1794-0E4XT T4 - 1794-IE4XOE2XT
UKEX/ATEX temp code	T4
IECEX temp code	T4

(1) Use this category information for planning conductor routing as described in the Industrial Automation Wiring and Grounding Guidelines, publication [1770-4.1](#).

Environmental Specifications

Attribute	Value
Temperature, operating	IEC 60068-2-1 (Test Ad, operating cold), IEC 60068-2-2 (Test Bd, operating dry heat), IEC 60068-2-14 (Test Nb, operating thermal shock): -20...+70 °C (-4...+158 °F)
Temperature, surrounding air, max	70 °C (158 °F)
Temperature, storage	IEC 60068-2-1 (Test Ab, unpackaged nonoperating cold), IEC 60068-2-2 (Test Bb, unpackaged nonoperating dry heat), IEC 60068-2-14 (Test Na, unpackaged nonoperating thermal shock): -40...+85 °C (-40...+185 °F)
Relative humidity	IEC 60068-2-30 (Test Db, unpackaged nonoperating damp heat): 5...95% noncondensing
Vibration	IEC60068-2-6 (Test Fc, operating): 5 g @ 10...500Hz
Shock, operating	IEC60068-2-27 (Test Ea, unpackaged shock): 30 g
Shock, nonoperating	IEC60068-2-27 (Test Ea, unpackaged shock): 50 g
Emissions	IEC 61000-6-4
ESD immunity	EC 61000-4-2: 6 kV contact discharges 8 kV air discharges
Radiated RF immunity	EC 61000-4-3: 10V/m with 1 kHz sine-wave 80% AM from 80...6000 MHz

Environmental Specifications (Continued)

Attribute	Value
Conducted RF immunity	IEC 61000-4-6: 10V rms with 1 kHz sine-wave 80% AM from 150 kHz...30 MHz
EFT/B immunity	IEC 61000-4-4: ±2 kV at 5 kHz on signal ports
Surge transient immunity	IEC 61000-4-5: ±1 kV line-line (DM) and ±2 kV line-earth (CM) on signal ports

Certifications

Certifications (when product is marked) ⁽¹⁾	Value
c-UL-us	UL Listed Industrial Control Equipment, certified for US and Canada. See UL File E65584. UL Listed for Class I Division 2 Group A,B,C,D Hazardous Locations, certified for U.S. and Canada. See UL File E194810.
UK and CE	UK Statutory Instrument 2016 No. 1091 and European Union 2014/30/EU EMC Directive, compliant with: EN 61326-1; Meas./Control/Lab., Industrial Requirements EN 61000-6-2; Industrial Immunity EN 61131-2; Programmable Controllers EN 61000-6-4; Industrial Emissions UK Statutory Instrument 2012 No. 3032 and European Union 2011/65/EU RoHS, compliant with: EN 63000; Technical documentation
Ex	UK Statutory Instrument 2016 No. 1107 and European Union 2014/34/EU ATEX Directive, compliant with: EN IEC 60079-0; General Requirements EN IEC 60079-7; Explosive Atmospheres, Protection "e" II 3 G Ex ec IIC T4 Gc DEMKO 14 ATEX 1342501X UL22UKEX2378X
IECEX	IECEX System, compliant with: IEC 60079-0; General Requirements IEC 60079-7; Explosive Atmospheres, Protection "e" Ex ec IIC T4 Gc IECEX UL 14.0066X
RCM	Australian Radiocommunications Act, compliant with: EN 61000-6-4; Industrial Emissions
KC	Korean Registration of Broadcasting and Communications Equipment, compliant with: Article 58-2 of Radio Waves Act, Clause 3
Morocco	Arrêté ministériel n° 6404-15 du 29 ramadan 1436
CCC	CNCA-C23-01 强制性产品认证实施规则 防爆电气 CNCA-C23-01 CCC Implementation Rule Explosion-Proof Electrical Products 202012230911829

(1) See the Product Certification link at rok.auto/certifications for Declaration of Conformity, Certificates, and other certification details.

Additional Resources

For more information on the products that are described in this publication, use these resources. You can view or download publications at rok.auto/literature.

Resource	Description
FLEX I/O and FLEX I/O-XT Selection Guide, publication 1794-SG002	A description and overview of the 1794 series FLEX I/O and FLEX I/O-XT™ modules and compatible control platforms.
FLEX I/O High-Density Analog Modules User Manual, publication 1794-UM062	Provides detailed information on how to use and configure your high-density analog modules.
Industrial Automation Wiring and Grounding Guidelines, publication 1770-4.1	Provides general guidelines for installing a Rockwell Automation industrial system.
Product Certifications website, rok.auto/certifications	Provides declarations of conformity, certificates, and other certification details.

Rockwell Automation Support

Use these resources to access support information.

Technical Support Center	Find help with how-to videos, FAQs, chat, user forums, Knowledgebase, and product notification updates.	rok.auto/support
Local Technical Support Phone Numbers	Locate the telephone number for your country.	rok.auto/phonesupport
Technical Documentation Center	Quickly access and download technical specifications, installation instructions, and user manuals.	rok.auto/techdocs
Literature Library	Find installation instructions, manuals, brochures, and technical data publications.	rok.auto/literature
Product Compatibility and Download Center (PCDC)	Download firmware, associated files (such as AOP, EDS, and DTM), and access product release notes.	rok.auto/pcdc

Documentation Feedback

Your comments help us serve your documentation needs better. If you have any suggestions on how to improve our content, complete the form at rok.auto/docfeedback.





Waste Electrical and Electronic Equipment (WEEE)



At the end of life, this equipment should be collected separately from any unsorted municipal waste.

Rockwell Automation maintains current product environmental compliance information on its website at rok.auto/pec.

Rockwell Otomasyon Ticaret A.Ş. Kar Plaza İş Merkezi E Blok Kat:6 34752 İçerenköy, İstanbul, Tel: +90 (216) 5698400 EEE Yönetmeliğine Uygundur

Connect with us.    

rockwellautomation.com — expanding **human possibility**[®]

AMERICAS: Rockwell Automation, 1201 South Second Street, Milwaukee, WI 53204-2496 USA, Tel: (1) 414.382.2000

EUROPE/MIDDLE EAST/AFRICA: Rockwell Automation NV, Pegasus Park, De Kleetlaan 12a, 1831 Diegem, Belgium, Tel: (32) 2663 0600

ASIA PACIFIC: Rockwell Automation SEA Pte Ltd, 2 Corporation Road, #04-05, Main Lobby, Corporation Place, Singapore 618494, Tel: (65) 6510 6608

UNITED KINGDOM: Rockwell Automation Ltd., Pitfield, Kiln Farm, Milton Keynes, MK11 3DR, United Kingdom, Tel: (44)(1908) 838-800

Allen-Bradley, expanding human possibility, FLEX I/O, FLEX I/O-XT, Rockwell Automation, and TechConnect are trademarks of Rockwell Automation, Inc. Trademarks not belonging to Rockwell Automation are property of their respective companies.

Publication 1794-IN125E-EN-P - June 2024 | Supersedes Publication 1794-IN125D-EN-P - July 2023
Copyright © 2024 Rockwell Automation, Inc. All rights reserved.