

# Installation Instructions

Original Instructions



**Allen-Bradley**

by ROCKWELL AUTOMATION

## FLEX I/O Very High-speed Counter Module

Catalog Number 1794-VHSC

Topic	Page
Summary of Changes	1
Overview	3
Install the Module	4
Wire the Module	4
Interpret the Status Indicators	8
Specifications	10
Additional Resources	13

### Summary of Changes

This publication contains the following new or updated information. This list includes substantive updates only and is not intended to reflect all changes.

Topic	Page
Updated Certifications	12



**ATTENTION:** Read this document and the documents listed in the Additional Resources section about installation, configuration and operation of this equipment before you install, configure, operate or maintain this product. Users are required to familiarize themselves with installation and wiring instructions in addition to requirements of all applicable codes, laws, and standards.

Activities including installation, adjustments, putting into service, use, assembly, disassembly, and maintenance are required to be carried out by suitably trained personnel in accordance with applicable code of practice. If this equipment is used in a manner not specified by the manufacturer, the protection provided by the equipment may be impaired.

注意：在安装、配置、操作和维护本产品前，请阅读本文档以及“其他资源”部分列出的有关设备安装、配置和操作的相应文档。除了所有适用规范、法律和标准的相关要求之外，用户还必须熟悉安装和接线说明。

安装、调整、投运、使用、组装、拆卸和维护等各项操作必须由经过适当训练的专业人员按照适用的操作规范实施。

如果未按照制造商指定的方式使用该设备，则可能会损害设备提供的保护。

**ATENCIÓN:** Antes de instalar, configurar, poner en funcionamiento o realizar el mantenimiento de este producto, lea este documento y los documentos listados en la sección Recursos adicionales acerca de la instalación, configuración y operación de este equipo. Los usuarios deben familiarizarse con las instrucciones de instalación y cableado y con los requisitos de todos los códigos, leyes y estándares vigentes.

El personal debidamente capacitado debe realizar las actividades relacionadas a la instalación, ajustes, puesta en servicio, uso, ensamblaje, desensamblaje y mantenimiento de conformidad con el código de práctica aplicable. Si este equipo se usa de una manera no especificada por el fabricante, la protección provista por el equipo puede resultar afectada.

**ATENÇÃO:** Leia este e os demais documentos sobre instalação, configuração e operação do equipamento que estão na seção Recursos adicionales antes de instalar, configurar, operar ou manter este produto. Os usuários devem se familiarizar com as instruções de instalação e operação além das especificações para todos os códigos, leis e normas aplicáveis.

É necessário que as atividades, incluindo instalação, ajustes, colocação em serviço, utilização, montagem, desmontagem e manutenção sejam realizadas por pessoal qualificado e especializado, de acordo com o código de prática aplicável.

Caso este equipamento seja utilizado de maneira não estabelecida pelo fabricante, a proteção fornecida pelo equipamento pode ficar prejudicada.

**ВНИМАНИЕ:** Перед тем как устанавливать, настраивать, эксплуатировать или обслуживать данное оборудование, прочитайте этот документ и документы, перечисленные в разделе «Дополнительные ресурсы». В этих документах изложены сведения об установке, настройке и эксплуатации данного оборудования. Пользователи обязаны ознакомиться с инструкциями по установке и прокладке соединений, а также с требованиями всех применимых норм, законов и стандартов.

Все действия, включая установку, наладку, ввод в эксплуатацию, использование, сборку, разборку и техническое обслуживание, должны выполняться обученным персоналом в соответствии с применимыми нормами и правилами.

Если оборудование используется не предусмотренным производителем образом, защита оборудования может быть нарушена.

注意：本製品を設置、構成、稼働または保守する前に、本書および本機器の設置、設定、操作についての参考資料の該当箇所に記載されている文書に目を通してください。ユーザーは、すべての該当する条例、法律、規格の要件に加えて、設置および配線の手順に習熟している必要があります。

設置調整、運転の開始、使用、組立て、解体、保守を含む諸作業は、該当する実施規則に従って訓練を受けた適切な作業員が実行する必要があります。

本機器が製造メーカーにより指定されていない方法で使用されている場合、機器により提供されている保護が損なわれる恐れがあります。

**ACHTUNG:** Lesen Sie dieses Dokument und die im Abschnitt „Weitere Informationen“ aufgeführten Dokumente, die Informationen zu Installation, Konfiguration und Bedienung dieses Produkts enthalten, bevor Sie dieses Produkt installieren, konfigurieren, bedienen oder warten. Anwender müssen sich neben den Bestimmungen aller anwendbaren Vorschriften, Gesetze und Normen zusätzlich mit den Installations- und Verdrahtungsanweisungen vertraut machen.

Arbeiten im Rahmen der Installation, Anpassung, Inbetriebnahme, Verwendung, Montage, Demontage oder Instandhaltung dürfen nur durch ausreichend geschulte Mitarbeiter und in Übereinstimmung mit den anwendbaren Ausführungsvorschriften vorgenommen werden.

Wenn das Gerät in einer Weise verwendet wird, die vom Hersteller nicht vorgesehen ist, kann die Schutzfunktion beeinträchtigt sein.

**ATTENTION:** Lisez ce document et les documents listés dans la section Ressources complémentaires relatifs à l'installation, la configuration et le fonctionnement de cet équipement avant d'installer, configurer, utiliser ou entretenir ce produit. Les utilisateurs doivent se familiariser avec les instructions d'installation et de câblage en plus des exigences relatives aux codes, lois et normes en vigueur. Les activités relatives à l'installation, le réglage, la mise en service, l'utilisation, l'assemblage, le démontage et l'entretien doivent être réalisées par des personnes formées selon le code de pratique en vigueur.

Si cet équipement est utilisé d'une façon qui n'a pas été définie par le fabricant, la protection fournie par l'équipement peut être compromise.

주의：본 제품 설치, 설정, 작동 또는 유지 보수하기 전에 본 문서를 포함하여 설치, 설정 및 작동에 관한 참고 자료 섹션의 문서들을 반드시 읽고 숙지하십시오. 사용자는 모든 관련 규정, 법규 및 표준에서 요구하는 사항에 대해 반드시 설치 및 배선 지침을 숙지해야 합니다.

설치, 조정, 가동, 조립, 분해, 유지보수 등 모든 작업은 관련 규정에 따라 적절한 교육을 받은 사용자를 통해서만 수행해야 합니다.

본 장비를 제조사가 명시하지 않은 방법으로 사용하면 장비의 보호 기능이 손상될 수 있습니다.

**ATTENZIONE:** Prima di installare, configurare ed utilizzare il prodotto, o effettuare interventi di manutenzione su di esso, leggere il presente documento ed i documenti elencati nella sezione "Altre risorse", riguardanti l'installazione, la configurazione ed il funzionamento dell'apparecchiatura. Gli utenti devono leggere e comprendere le istruzioni di installazione e cablaggio, oltre ai requisiti previsti dalle leggi, codici e standard applicabili.

Le attività come installazione, regolazioni, utilizzo, assemblaggio, disassemblaggio e manutenzione devono essere svolte da personale adeguatamente addestrato, nel rispetto delle procedure previste.

Qualora l'apparecchio venga utilizzato con modalità diverse da quanto previsto dal produttore, la sua funzione di protezione potrebbe venire compromessa.

**DIKKAT:** Bu ürünün kurulumu, yapılandırılması, işletilmesi veya bakımı öncesinde bu dokümanı ve bu ekipmanın kurulumu, yapılandırılması ve işletimi ile ilgili ilave Kaynaklar bölümünde yer listelenmiş dokümanları okuyun. Kullanıcılar yürürlükteki tüm yönetmelikler, yasalar ve standartların gereksinimlerine ek olarak kurulum ve kablolama talimatlarını da öğrenmek zorundadır.

Kurulum, ayarlama, hizmete alma, kullanma, parçaları birleştirme, parçaları sökme ve bakım gibi aktiviteler sadece uygun eğitimli almış kişiler tarafından yürürlükteki uygulama yönetmeliklerine uygun şekilde yapılabilir.

Bu ekipman üretici tarafından belirlenmiş amacın dışında kullanılırsa, ekipman tarafından sağlanan koruma bozulabilir.

注意事項：在安装、設定、操作或維護本產品前，請先閱讀此文件以及列於「其他資源」章節中所有有關安裝、設定與操作此設備的文件。使用者必須熟悉安裝和配線指示，並符合所有法規、法律和標準要求。

包括安裝、調整、交付使用、使用、組裝、拆卸和維護等動作都必須交由已經過適當訓練的人員進行，以符合適用的實作法規。

如果將設備用於非製造商指定的用途時，可能會造成設備所提供的保護功能受損。

**POZOR:** Než začnete instalovat, konfigurovat či provozovat tento výrobek nebo provádět jeho údržbu, přečtěte si tento dokument a dokumenty uvedené v části Dodatečné zdroje ohledně instalace, konfigurace a provozu tohoto zařízení. Uživatelé se musejí vedle požadavků všech relevantních vyhlášek, zákonů a norem nutně seznámit také s pokyny pro instalaci a elektrické zapojení.

Činnosti zahrnující instalaci, nastavení, uvedení do provozu, užívání, montáž, demontáž a údržbu musí vykonávat vhodně proškolený personál v souladu s příslušnými prováděcími předpisy.

Pokud se toto zařízení používá způsobem neodpovídajícím specifikaci výrobce, může být narušena ochrana, kterou toto zařízení poskytuje.

**UWAGA:** Przed instalacją, konfiguracją, użytkowaniem lub konserwacją tego produktu należy przeczytać niniejszy dokument oraz wszystkie dokumenty wymienione w sekcji Dodatkowe źródła omawiające instalację, konfigurację i procedury użytkowania tego urządzenia. Użytkownicy mają obowiązek zapoznać się z instrukcjami dotyczącymi instalacji oraz oprzewodowania, jak również z obowiązującymi kodeksami, prawem i normami.

Działania obejmujące instalację, regulację, przekazanie do użytkowania, użytkowanie, montaż, demontaż oraz konserwację muszą być wykonywane przez odpowiednio przeszkolony personel zgodnie z obowiązującym kodeksem postępowania.

Jeśli urządzenie jest użytkowane w sposób inny niż określony przez producenta, zabezpieczenie zapewniane przez urządzenie może zostać ograniczone.

**OBBS!** Läs detta dokument samt dokumentet, som står listat i avsnittet Övriga resurser, om installation, konfiguration och drift av denna utrustning innan du installerar, konfigurerar eller börjar använda eller utföra underhållsarbete på produkten. Användare måste bekanta sig med instruktioner för installation och kabeldragning, förutom krav enligt gällande koder, lagar och standarder.

Åtgärder som installation, justering, service, användning, montering, demontering och underhållsarbete måste utföras av personal med lämplig utbildning enligt lämpligt bruk.

Om denna utrustning används på ett sätt som inte anges av tillverkaren kan det hända att utrustningens skyddsanordningar försätts ur funktion.

**LET OP:** Lees dit document en de documenten die genoemd worden in de paragraaf Aanvullende informatie over de installatie, configuratie en bediening van deze apparatuur voordat u dit product installeert, configureert, bedient of onderhoudt. Gebruikers moeten zich vertrouwd maken met de installatie en de bedravingsinstructies, naast de vereisten van alle toepasselijke regels, wetten en normen.

Activiteiten zoals het installeren, afstellen, in gebruik stellen, gebruiken, monteren, demonteren en het uitvoeren van onderhoud mogen uitsluitend worden uitgevoerd door hiervoor opgeleid personeel en in overeenstemming met de geldende praktijkregels.

Indien de apparatuur wordt gebruikt op een wijze die niet is gespecificeerd door de fabrikant, dan bestaat het gevaar dat de beveiliging van de apparatuur niet goed werkt.

## Environment and Enclosure



**ATTENTION:** This equipment is intended for use in a Pollution Degree 2 industrial environment, in overvoltage Category II applications (as defined in EN/IEC 60664-1), at altitudes up to 2000 m (6562 ft) without derating. This equipment is not intended for use in residential environments and may not provide adequate protection to radio communication services in such environments.

This equipment is supplied as open-type equipment for indoor use. It must be mounted within an enclosure that is suitably designed for those specific environmental conditions that will be present and appropriately designed to prevent personal injury resulting from accessibility to live parts. The enclosure must have suitable flame-retardant properties to prevent or minimize the spread of flame, complying with a flame spread rating of 5VA or be approved for the application if nonmetallic. The interior of the enclosure must be accessible only by the use of a tool. Subsequent sections of this publication may contain more information regarding specific enclosure type ratings that are required to comply with certain product safety certifications.

In addition to this publication, see:

- Industrial Automation Wiring and Grounding Guidelines, publication [1770-4.1](#), for more installation requirements.
- NEMA Standard 250 and EN/IEC 60529, as applicable, for explanations of the degrees of protection provided by enclosures.

## Prevent Electrostatic Discharge



**ATTENTION:** This equipment is sensitive to electrostatic discharge, which can cause internal damage and affect normal operation. Follow these guidelines when you handle this equipment:

- Touch a grounded object to discharge potential static.
- Wear an approved grounding wriststrap.
- Do not touch connectors or pins on component boards.
- Do not touch circuit components inside the equipment.
- Use a static-safe workstation, if available.
- Store the equipment in appropriate static-safe packaging when not in use.



**ATTENTION:** This product is grounded through the DIN rail to chassis ground. Use zinc-plated chromate-passivated steel DIN rail to assure proper grounding. The use of other DIN rail materials (for example, aluminum or plastic) that can corrode, oxidize, or are poor conductors, can result in improper or intermittent grounding. Secure DIN rail to mounting surface approximately every 200 mm (7.8 in.) and use end-anchors appropriately. Be sure to ground the DIN rail properly. See Industrial Automation Wiring and Grounding Guidelines, Rockwell Automation publication [1770-4.1](#), for more information.

## Overview

The FLEX™ I/O very high-speed counter module performs high speed counting for industrial applications. The module is an intelligent I/O module that interfaces signals with any Allen-Bradley® programmable controller that has Ethernet capability.

### FLEX I/O Very High-speed Counter Module - 1794-VHSC

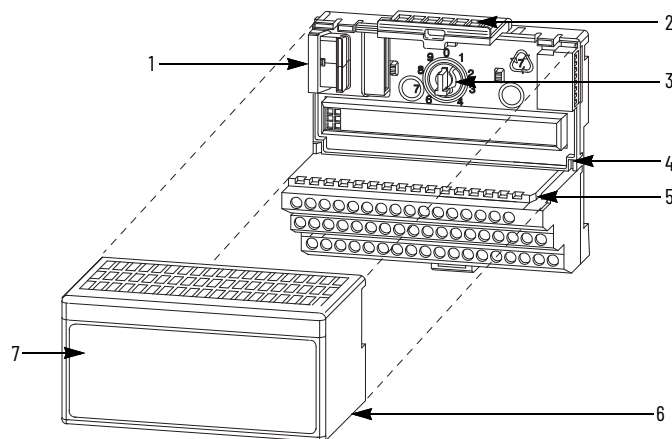

## Component Identification

	Description		Description		Description
1	Flexbus connector	4	Terminal base	6	Module alignment bar
2	Latching mechanism	5	Terminal base alignment groove	7	Module
3	Keyswitch				

## Install the Module

Read this for information on how to install the FLEX I/O module, which mounts on a 1794-TB3G or 1794-TB3GS terminal base.



**ATTENTION:** During mounting of all devices, be sure that all debris (metal chips, wire strands, and so on) are kept from falling into the module. Debris that falls into the module could cause damage on power-up.

## Mount on Terminal Base

1. Rotate the keyswitch (3) on the terminal base (4) clockwise to position 1 as required for this type of module.
2. Make sure the Flexbus connector (1) is pushed all the way to the left to connect with the neighboring terminal base or adapter. **You cannot install the module unless the connector is fully extended.**
3. Make sure that the pins on the bottom of the module are straight so that they align properly with the connector in the terminal base.
4. Position the module (7) with its alignment bar (6) aligned with the groove (5) on the terminal base.
5. Press firmly and evenly to seat the module in the terminal base unit. The module is seated when the latching mechanism (2) is locked into the module.

## Wire the Module



**ATTENTION:** To reduce susceptibility to noise, power analog modules and digital modules from separate power supplies. Do not exceed a length of 3 m (9.8 ft) for DC power cabling.



**ATTENTION:** Do not daisy chain power or ground from this terminal base unit to any AC or DC digital module terminal base units.



**ATTENTION:** Do not wire more than two conductors on any single terminal.

**IMPORTANT** We recommend that you use a twisted-pair, individually shielded cable with a maximum length of 300 m (1000 ft).

To connect wiring for 1794-TB3G and 1794-TB3GS terminal bases, see [Figure 1](#) and [Table 1](#) to complete the following:

Figure 1 - Wiring for 1794-TB3G and 1794-TB3GS

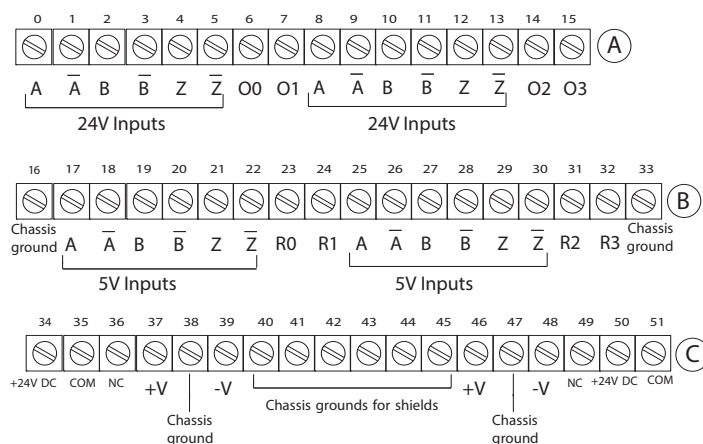

Where:

- A,  $\bar{A}$  = incremental encoder input A (+5V DC or +24V DC)
- B,  $\bar{B}$  = incremental encoder input B (+5V DC or +24V DC)
- Z,  $\bar{Z}$  = incremental encoder input Z (+5V DC or +24V DC)
- 0 = sourcing outputs
- Input power for Output 00 (A-6); Output 01 (A-7) - C-37 (+) and C-39 (-)
- Input power for Output 02 (A-14); Output 03 (A-14) - C-46 (+) and C-48 (-)
- R = returns for sourcing outputs
- +V = +5V or +24V DC isolated power externally supplied for outputs (1 A max)
- V = negative isolated power connection (1 A max)
- +24V DC = 24V DC terminal base power for module
- COM = return for 24V DC terminal base power for module
- Chassis ground = chassis ground for input or output cable shields
- NC = No Connection

**Table 1 - Wiring Connections**

Encoder Inputs	Channel 0		Channel 1	
	24V Inputs	5V Inputs	24V Inputs	5V Inputs
A	A-0	B-17	A-8	B-25
A	A-1	B-18	A-9	B-26
B	A-2	B-19	A-10	B-27
B	A-3	B-20	A-11	B-28
Z	A-4	B-21	A-12	B-29
Z	A-5	B-22	A-13	B-30
Outputs	Source Out	Return		
00	A-6	B-23		
01	A-7	B-24		
02	A-14	B-31		
03	A-15	B-32		
24V DC	Terminals C-34 and C-50			
24V COM	Terminals C-35 and C-51			
5V or 24V output power	Terminals C-37 and C-46			
-V output power	Terminals C-39 and C-48			
Chassis ground	Terminals B-16, B-33, C-38, C-40...C-45, C-47			



**ATTENTION:** Do not connect 24V signals to the +5V input terminals. It can result in permanent damage to the module.

### Block-transfer Read and Write

The following block-transfer read and write word bit information is presented for experienced users only.

#### Input Map (Read)

Dec	15	14	13	12	11	10	9	0	7	6	5	4	3	2	1	0
Oct	17	16	15	14	13	12	11	10	7	6	5	4	3	2	1	0
Word 0	Channel 0 Current Count (least significant word)															
1	Channel 0 Current Count (most significant word)															
2	Channel 1 Current Count (least significant word)															
3	Channel 1 Current Count (most significant word)															
4	Channel 0 Stored/Accumulated Count (least significant word)															
5	Channel 0 Stored/Accumulated Count (most significant word)															
6	Channel 1 Stored/Accumulated Count (least significant word)															
7	Channel 1 Stored/Accumulated Count (most significant word)															
8	PE	FP	NR	TF	OS 3	OS 2	OS 1	OS 0	C1	C0	ZF	ZS	C1	C0	ZF	ZS

Where:

- PE = Programming error (error code in bits 11:0)
- FP = Field power (24V DC power lost)
- NR = Not ready (configuring field programmable array FPGA)
- TF = Test fail flag = 1 (indicating failure during power-up) red indicator on.  
Code in bits 2:0 indicate fail code (1 = RAM; 2 = ROM; 3 = EEPROM; 4 = FPGA)  
Test flag = 1 with red indicator blinking, upper byte of counter control word in nonzero - in production test mode.
- OS = Output status (current state of output)
- C1, C0 = Stored data count
- ZF = Zero frequency detected
- ZS = Z input status

### Output Map (Write)

Dec	15	14	13	12	11	10	9	0	7	6	5	4	3	2	1	0
Oct	17	16	15	14	13	12	11	10	7	6	5	4	3	2	1	0
Word 0	Reserved for test								0	VR1	CP1	CR1	0	VRO	CPO	CRO
1	0	LC3	OE3	F03	0	LC2	OE2	F02	0	LC1	OE1	F01	0	LCO	OE0	F00
2	Channel 0 PWM Output Value (0...95.00%)															
3	Channel 1 PWM Output Value (0...95.00%)															
Where:	VR = Value reset of stored/accumulated count (channel) CP = Counter preset (channel) CR = Counter reset (channel) LC = Local control (channel) - Outputs remain under control when Flexbus is not powered - 1 = enabled OE = Output enable (channel) - Permitting output to be turned on from FO, compare match, or PWM - 1 = enabled FO = Forced output (channel) - 1 = on PWM = Pulse-width modulation (0...9,500 decimal)															

### Configuration Image

When a configuration is sent to the module, it is checked for consistency before being applied. If an error is found, the PE bit is asserted and the module locally retains its previous configuration. Your user application program should monitor the PE bit.

### Configuration Map

Dec	15	14	13	12	11	10	9	0	7	6	5	4	3	2	1	0
Oct	17	16	15	14	13	12	11	10	7	6	5	4	3	2	1	0
0	Counter Configuration															
1	Filter Selection															
2	Time Base Value/PWM Period															
3	Channel 0 Gate Interval															
4	Channel 1 Gate Interval															
5	Reserved															
6	Channel 0 Rollover Value (least significant word)															
7	Channel 0 Rollover Value (most significant word)															
8	Channel 1 Rollover Value (least significant word)															
9	Channel 1 Rollover Value (most significant word)															
10	Channel 0 Preset Value (least significant word)															
11	Channel 0 Preset Value (most significant word)															
12	Channel 1 Preset Value (least significant word)															
13	Channel 1 Preset Value (most significant word)															
14	Channel 0 Scaler															
15	Channel 1 Scaler															
16	0	0	0	0	0	0	0	0	S4	S3	S2	S1	F4	F3	F2	F1
17	0	0	0	0	0	0	0	0	S4	S3	S2	S1	F4	F3	F2	F1
18	0	0	0	0	0	0	0	0	S4	S3	S2	S1	F4	F3	F2	F1
19	0	0	0	0	0	0	0	0	S4	S3	S2	S1	F4	F3	F2	F1
20	First Counter 1 <sup>st</sup> ON Value (least significant word)															
21	First Counter 1 <sup>st</sup> ON Value (most significant word)															
22	First Counter 1 <sup>st</sup> OFF Value (least significant word)															
23	First Counter 1 <sup>st</sup> OFF Value (most significant word)															
24	First Counter 2 <sup>nd</sup> ON Value (least significant word)															
25	First Counter 2 <sup>nd</sup> ON Value (most significant word)															
26	First Counter 2 <sup>nd</sup> OFF Value (least significant word)															
27	First Counter 2 <sup>nd</sup> OFF Value (most significant word)															
28	First Counter 3 <sup>rd</sup> ON Value (least significant word)															
29	First Counter 3 <sup>rd</sup> ON Value (most significant word)															
30	First Counter 3 <sup>rd</sup> OFF Value (least significant word)															
31	First Counter 3 <sup>rd</sup> OFF Value (most significant word)															

**Configuration Map (Continued)**

<b>Dec</b>	<b>15</b>	<b>14</b>	<b>13</b>	<b>12</b>	<b>11</b>	<b>10</b>	<b>9</b>	<b>0</b>	<b>7</b>	<b>6</b>	<b>5</b>	<b>4</b>	<b>3</b>	<b>2</b>	<b>1</b>	<b>0</b>
<b>Oct</b>	<b>17</b>	<b>16</b>	<b>15</b>	<b>14</b>	<b>13</b>	<b>12</b>	<b>11</b>	<b>10</b>	<b>7</b>	<b>6</b>	<b>5</b>	<b>4</b>	<b>3</b>	<b>2</b>	<b>1</b>	<b>0</b>
32	First Counter 4 <sup>th</sup> ON Value (least significant word)															
33	First Counter 4 <sup>th</sup> ON Value (most significant word)															
34	First Counter 4 <sup>th</sup> OFF Value (least significant word)															
35	First Counter 4 <sup>th</sup> OFF Value (most significant word)															
36	Second Counter 1 <sup>st</sup> ON Value (least significant word)															
37	Second Counter 1 <sup>st</sup> ON Value (most significant word)															
38	Second Counter 1 <sup>st</sup> OFF Value (least significant word)															
39	Second Counter 1 <sup>st</sup> OFF Value (most significant word)															
40	Second Counter 2 <sup>nd</sup> ON Value (least significant word)															
41	Second Counter 2 <sup>nd</sup> ON Value (most significant word)															
42	Second Counter 2 <sup>nd</sup> OFF Value (least significant word)															
43	Second Counter 2 <sup>nd</sup> OFF Value (most significant word)															
44	Second Counter 3 <sup>rd</sup> ON Value (least significant word)															
45	Second Counter 3 <sup>rd</sup> ON Value (most significant word)															
46	Second Counter 3 <sup>rd</sup> OFF Value (least significant word)															
47	Second Counter 3 <sup>rd</sup> OFF Value (most significant word)															
48	Second Counter 4 <sup>th</sup> ON Value (least significant word)															
49	Second Counter 4 <sup>th</sup> ON Value (most significant word)															
50	Second Counter 4 <sup>th</sup> OFF Value (least significant word)															
51	Second Counter 4 <sup>th</sup> OFF Value (most significant word)															
52	Counter Control Safe State															
53	Output Control Safe State															
54	Channel 0 PWM Safe State															
55	Channel 1 PWM Safe State															

**Counter Configuration/Mode (Configuration Word 0)**

<b>Bit</b>	<b>7</b>	<b>6</b>	<b>5</b>	<b>4</b>	<b>3</b>	<b>2</b>	<b>1</b>	<b>0</b>	<b>Counter 0</b>
<b>Bit</b>	<b>15</b>	<b>14</b>	<b>13</b>	<b>12</b>	<b>11</b>	<b>10</b>	<b>9</b>	<b>8</b>	<b>Counter 1</b>
	<b>Mode</b>				<b>Configuration</b>				<b>Description</b>
					0	0	0	0	Counter
					0	0	0	1	Encoder X1
					0	0	1	0	PWM
					0	1	0	0	Encoder X4
					0	1	0	1	Period/Rate
					0	1	1	0	Continuous/Rate
					0	1	1	1	Rate Measurement
	0	0	0						Store Count Disabled
	0	0	1						Mode 1 – Store/Continue
	0	1	0						Mode 2 – Store; Reset/Resume
	0	1	1						Mode 3 – Store; Reset/Wait/Start
	1	0	0						Mode 4 – Store; Reset/Start
	110 and 111								Reserved
	0								Z input not inverted
	1								Z input inverted

### Filter Selection (Configuration Word 1)

Bit	7	6	5	4	3	2	1	0	Counter 0
Bit	15	14	13	12	11	10	9	8	Counter 1
0	ZF	BF	AF	Filter				Description	
				0	0	0	0	0	No filter
				0	0	0	1	1	50 kHz (10 μs + 0 μs/-1.6 μs)
				0	0	1	0	0	5 kHz (100 μs + 0 μs/-13.2 μs)
				0	1	0	0	0	500 Hz (1.0 ms + 0 ms/-125 μs)
				1	0	0	0	0	50 Hz (10.0 ms + 0 ms/-1.25 ms)
			0						A input not filtered
			1						A input filtered
		0							B input not filtered
		1							B input filtered
	0								Z input not filtered
	1								Z input filtered

### Interpret the Status Indicators

This module has one red/green power/status indicator (OK), and one yellow indicator for each input and output. The I/O status indicators are multiplexed in 2 groups (A0, B0, Z0, 00, 01); and (A1, B1, Z1, 02, 03) at a frequency of 488 Hz. If inputs or outputs change at or near that frequency, the indicators vary in brightness.

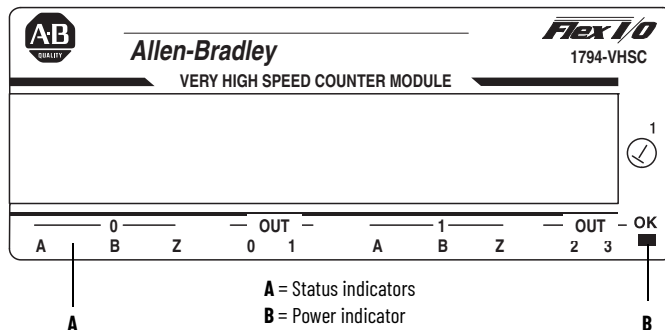

### Input and Output Status Indicators

Indicator	Status	Description
A (status of input A)	Yellow	The input A is active.
	Off	The input A is not active.
B (status of input B)	Yellow	The input B is active.
	Off	The input B is not active.
Z (status of input Z)	Yellow	The input Z is active.
	Off	The input Z is not active.
Out 0, 1, 2, 3	Yellow	The output is On.
	Off	Individual output is Off.

When an active indicator (yellow) is lighted, a valid signal (active high or active low) is present at the input terminals. The module power/status indicator (OK) shows that power is applied to the module, and the status of the module.

### Module Status Indicators

Indicator	Status	Description
OK	Steady red	<ul style="list-style-type: none"> <li>Hardware diagnostic error, TF set to 1 and module/channel status contains error code.</li> <li>Hardware runtime failure (that is, watchdog timeout), module communication ceases.</li> </ul>
	Flashing red	<ul style="list-style-type: none"> <li>The module is configuring hardware, NR is set to 1.</li> <li>The module is in test mode (bits 8...15 of counter control word are nonzero), TF set to 1.</li> </ul>
	Flashing red with occasional flashing green	<ul style="list-style-type: none"> <li>The module 24V power is below minimum rating.</li> </ul>
	Steady green	<ul style="list-style-type: none"> <li>The module is active and behaving normally.</li> </ul>
	Flashing green	<ul style="list-style-type: none"> <li>The module is not configured.</li> <li>Programming error, PE is set to 1 and the error code is supplied in bits 0...11 of the module/channel status word.</li> <li>Field power fault, FP set to 1.</li> <li>Adapter powered down, and module local power still active.</li> <li>The ControlNet<sup>®</sup> cable is disconnected.</li> <li>PLC in PROG mode.</li> </ul>

### Diagnostic Codes Returned by the Module

If an incomplete, incorrect, or conflicting set of configuration parameters is sent to the module, the PE bit is asserted, the green module status indicator flashes, and an error code is displayed in bits 0...11 of the module/channel status word. The codes are identified in [Table 2](#). Use a CIO instruction to access this information.

**Table 2 - Diagnostics Reported by Input Data Word 8**

Read Word	Bit	Description
Word 8	00	A reserved configuration or mode was programmed.
	01	ZF/BF/AF were selected and no filter was programmed, or multiple filters were selected.
	02	A time base was entered that was not a multiple of 10, or the time base is out of range (>3000, that is 3 s).
	03	A configuration that requires a time base was selected and no gate interval was set, or the gate interval is out of range (>3 s) or the product of time base and gate interval is greater than 3 s.
	04	A rollover of zero was programmed through PWM was not selected; a rollover was programmed and PWM was selected; or the rollover is out of range (1 < rollover < 16,777,216).
	05	The preset (1 < preset < 16,777,216) is out of range.
	06	A configuration was selected that requires a scalar, and no scalar was programmed or multiple scalars were selected.
	07	A tie has been connected to an unprogrammed window.
	08	Counter 0 window ON and OFF values are equal and not zero or counter 0 window ON and OFF value greater than 16,777,215.
	09	Counter 1 window ON and OFF values are equal and not zero or counter 1 window ON and OFF value greater than 16,777,215.
	10	Reserved
11		

During hardware self-tests, when either Flexbus power or terminal base power is first applied and a fatal error occurs, the TF bit is asserted and the red module/power status indicator comes on. An error code is placed in the lower byte of the module/channel status word to indicate the failed resource. Use a CIO instruction to access this information. When using the CIO instruction, this would be word 10.

### Word 9 Bit Description

Read Word	Bit	02	01	00	Dec.	Definition
Word 9	00...07	0	0	1	1	RAM test failed.
		0	1	0	2	ROM checksum test failed.
		0	1	1	3	EEPROM test failed.
		1	0	0	4	Programmable Gate Array loading failed.
		All other combinations are not used.				

## Specifications

### Input Specifications

Attribute	Value
Number of input channels	2
Number of inputs per counter	2 groups of A/ $\overline{A}$ , B/ $\overline{B}$ , and Z/ $\overline{Z}$ pairs with 5V DC or 15...24V DC terminations
Input voltage, determined by the terminal base terminations	5V DC or 15...24V DC
Input current	5V DC terminations: 19.1 mA @ 5V DC 25.7 mA @ 6V DC  15...24V DC terminations: 6.1 mA @ 15V DC 10.2 mA @ 24V DC
Voltage, input, off-state	5V DC terminations: $\leq 1.25V$ DC 15...24V DC terminations: $\leq 1.8V$ DC
Current, input, off-state	$\leq 0.25$ mA
Voltage, input, on-state	5V DC terminations: $\geq 2.6V$ DC 15...24V DC terminations: $\geq 12.5V$ DC
Current, input, on-state	$\geq 5$ mA
Voltage, on-state, max	5V DC terminations: $\pm 6V$ 15...24V DC terminations. See <a href="#">Derating Curve on page 12</a> .
Input frequency, max	1.0 MHz counter and encoder X1 (no filters) 500 kHz encoder X2 (no filters) 250 kHz encoder X4 (no filters)
Input filter selections	Off, 10 $\mu$ s, 100 $\mu$ s, 1.0 ms, 10.0 ms per A/B/Z group

### Output Specifications

Attribute	Value
Number of outputs	2 isolated groups of 2: (0.5 A @ 5V DC, max; 1.0 A @ 12...24V DC, max)
Output control	Outputs can be tied to 8 compare windows
Voltage range, output supply	5...7V DC 10...31V DC
Leakage current, off-state	Less than 300 $\mu$ A
Voltage drop, on-state	5V DC terminations: 0.9V DC @ 0.5 A 12...24V DC terminations: 0.9V DC @ 1.0 A
Current, on-state, max	5V DC terminations: 0.5 A 12...24V DC terminations: 1.0 A
Current per output pair, max	5V DC terminations: 0.5 A 12...24V DC terminations: 1.0 A
Short circuit current	5V DC terminations: 0.9 A 12...24V DC terminations: 4.0 A The outputs are short-circuit protected and turned off until power is cycled.
Surge current	2 A for 50 ms, repeatable every 2 s
Delay time, Off to On	25 $\mu$ s (load dependent)
Delay time, On to Off	150 $\mu$ s (load dependent)

## General Specifications

Attribute	Value
Module location	1794-TB3G and 1794-TB3GS
External DC power supply voltage range, nom	24V DC
External DC power supply voltage	19.2...31.2V DC (includes 5% AC ripple)
External DC power supply current	100 mA @ 24V DC
Dimensions, H x W x D, with module installed on terminal base, approx.	94 x 94 x 69 mm (3.7 x 3.7 x 2.7 in.)
Isolation voltage	50V (continuous), Basic Insulation Type, between six isolated areas including: Flexbus Module 24V DC power A0/B0/Z0 inputs A1/B1/Z1 inputs 00/01 and output power supply 1 02/03 and output power supply 2 Tested @ 850V DC for 1 s
Flexbus current	75 mA @ 5V DC (with terminal base power off)
Power dissipation, max	5.0 W @ 31.2V DC
Thermal dissipation, max	17.1 BTU/hr @ 31.2V DC
Indicators (field side driven, logic side indication)	Power/status indicator - 1 green/red Input status indicators - logic side - 6 yellow Output status indicators - logic side - 4 yellow
Keyswitch position	1
Enclosure type rating	None (open-style)
Wire size	Determined by the installed terminal base
Wiring category <sup>(1)</sup>	2 - on signal ports 2 - on power ports
Terminal base screw torque	Determined by the installed terminal base

(1) Use this Conductor Category information for planning conductor routing. See Industrial Automation Wiring and Grounding Guidelines, publication [1770-4.1](#).

## Environmental Specifications

Attribute	Value
Temperature, operating	IEC 60068-2-1 (Test Ad, Operating Cold), IEC 60068-2-2 (Test Bd, Operating Dry Heat), IEC 60068-2-14 (Test Nb, Operating Thermal Shock): 0...55 °C (32...131 °F)
Temperature, nonoperating	IEC 60068-2-1 (Test Ab, Unpackaged Nonoperating Cold), IEC 60068-2-2 (Test Bb, Unpackaged Nonoperating Dry Heat), IEC 60068-2-14 (Test Na, Unpackaged Nonoperating Thermal Shock): -40...+85 °C (-40...+185 °F)
Surrounding air temperature, max	55 °C (131 °F)
Relative humidity	IEC 60068-2-30 (Test Db, Unpackaged Damp Heat): 5...95% noncondensing
Vibration	IEC60068-2-6 (Test Fc, Operating): 5 g @ 10...500 Hz
Shock, operating	IEC60068-2-27 (Test Ea, Unpackaged shock): 30 g
Shock, nonoperating	IEC60068-2-27 (Test Ea, Unpackaged shock): 50 g
Conducted emission	IEC 61000-6-4: 0.15...30 MHz on power ports.
ESD immunity	IEC 61000-4-2: ±6 kV direct and indirect contact discharges ±8 kV air discharges
Radiated RF immunity	IEC 61000-4-3: 10V/m with 1 kHz 80% AM 3 s dwell time from 80...6000 MHz 10V/m with 200 Hz 50% Pulse 100% AM 3 s dwell time at 900 MHz 10V/m with 200 Hz 50% Pulse 100% AM 3 s dwell time at 1890 MHz

**Environmental Specifications (Continued)**

Attribute	Value
EFT/B immunity	IEC 61000-4-4: ±2 kV @ 5 kHz on power ports ±2 kV @ 5 kHz on signal ports ±4 kV @ 5 kHz & 100 kHz on earth port
Surge transient immunity	IEC 61000-4-5: ±1 kV line-line(DM) and ±2 kV line-earth(CM) on power ports with IO coupling ±1 kV line-line(DM) and ±2 kV line-earth(CM) on signal ports with IO coupling ±2 kV line-earth(CM) on shielded ports with HVO coupling
Conducted RF immunity	IEC 61000-4-6: 10V rms with 1 kHz sine wave 80% AM 3 s dwell time from 0.15...80 MHz on power and earth port 10V rms with 1 kHz sine wave 80% AM 3 s dwell time from 0.15...80 MHz on shielded ports  Bridge and Deck Zone: 10V rms with 1 kHz sine wave 80% AM 3 s dwell time at sensitive frequencies on power, signal, and earth port

**Certifications**

Certifications (when product is marked) <sup>(1)</sup>	Value
CE	European Union 2014/30/EU EMC Directive, compliant with: EN 61326-1; Meas./Control/Lab., Industrial Requirements EN 61000-6-2; Industrial Immunity EN 61131-2; Programmable Controllers EN 61000-6-4; Industrial Emissions  European Union 2011/65/EU RoHS, compliant with: EN 50581; Technical documentation
RCM	Australian Radiocommunications Act, compliant with: EN 61000-6-4; Industrial Emissions
KC	Korean Registration of Broadcasting and Communications Equipment, compliant with: Article 58-2 of Radio Waves Act, Clause 3
Morocco	Arrêté ministériel n° 6404-15 du 29 ramadan 1436

(1) See the Product Certification link at [rok.auto/certifications](http://rok.auto/certifications) for Declarations of Conformity, Certificates, and other certification details.

**Derating Curve**

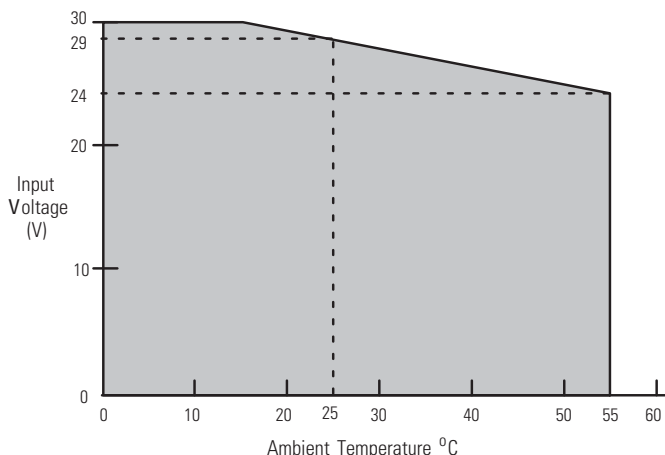

The area within the curve represents the safe operating range for the module under various conditions of user supplied 24V DC supply voltages and ambient temperatures. This includes all possible mounting positions, including inverted horizontal.

## Additional Resources

These documents contain more information about related products from Rockwell Automation. You can view or download publications at [rok.auto/literature](http://rok.auto/literature).

Resource	Description
FLEX I/O Very High-speed Counter Module User Manual, publication <a href="#">1794-UM010</a>	Describes how to configure and use a FLEX I/O Very High-speed Counter module.
FLEX I/O and FLEX I/O-XT Selection Guide, publication <a href="#">1794-SG002</a>	Provides specifications for selecting FLEX I/O and FLEX I/O-XT™ products.
Industrial Automation Wiring and Grounding Guidelines, publication <a href="#">1770-4.1</a>	Provides general guidelines for installing a Rockwell Automation industrial system.
Product Certifications website, <a href="http://rok.auto/certifications">rok.auto/certifications</a>	Provides declarations of conformity, certificates, and other certification details.

## Rockwell Automation Support

Use these resources to access support information.

<b>Technical Support Center</b>	Find help with how-to videos, FAQs, chat, user forums, Knowledgebase, and product notification updates.	<a href="http://rok.auto/support">rok.auto/support</a>
<b>Local Technical Support Phone Numbers</b>	Locate the telephone number for your country.	<a href="http://rok.auto/phonesupport">rok.auto/phonesupport</a>
<b>Technical Documentation Center</b>	Quickly access and download technical specifications, installation instructions, and user manuals.	<a href="http://rok.auto/techdocs">rok.auto/techdocs</a>
<b>Literature Library</b>	Find installation instructions, manuals, brochures, and technical data publications.	<a href="http://rok.auto/literature">rok.auto/literature</a>
<b>Product Compatibility and Download Center (PCDC)</b>	Download firmware, associated files (such as AOP, EDS, and DTM), and access product release notes.	<a href="http://rok.auto/pcdc">rok.auto/pcdc</a>

## Documentation Feedback

Your comments help us serve your documentation needs better. If you have any suggestions on how to improve our content, complete the form at [rok.auto/docfeedback](http://rok.auto/docfeedback).





## Waste Electrical and Electronic Equipment (WEEE)



At the end of life, this equipment should be collected separately from any unsorted municipal waste.

Rockwell Automation maintains current product environmental compliance information on its website at [rok.auto/pec](http://rok.auto/pec).

Rockwell Otomasyon Ticaret A.Ş. Kar Plaza İş Merkezi E Blok Kat:6 34752 İçerenköy, İstanbul, Tel: +90 (216) 5698400 EEE Yönetmeliğine Uygundur

Connect with us.    

**rockwellautomation.com** — expanding **human possibility**<sup>®</sup>

AMERICAS: Rockwell Automation, 1201 South Second Street, Milwaukee, WI 53204-2496 USA, Tel: (1) 414.382.2000

EUROPE/MIDDLE EAST/AFRICA: Rockwell Automation NV, Pegasus Park, De Kleetlaan 12a, 1831 Diegem, Belgium, Tel: (32) 2663 0600

ASIA PACIFIC: Rockwell Automation SEA Pte Ltd, 2 Corporation Road, #04-05, Main Lobby, Corporation Place, Singapore 618494, Tel: (65) 6510 6608

UNITED KINGDOM: Rockwell Automation Ltd., Pitfield, Kiln Farm, Milton Keynes, MK11 3DR, United Kingdom, Tel: (44)(1908) 838-800

Allen-Bradley, expanding human possibility, FactoryTalk, FLEX, FLEX I/O-XT, Rockwell Automation, and TechConnect are trademarks of Rockwell Automation, Inc.

ControlNet is a trademark of ODVA, Inc

Trademarks not belonging to Rockwell Automation are property of their respective companies.

Publication 1794-IN067E-EN-P - March 2024 | Supersedes Publication 1794-IN067D-EN-P - May 2022

Copyright © 2024 Rockwell Automation, Inc. All rights reserved.