

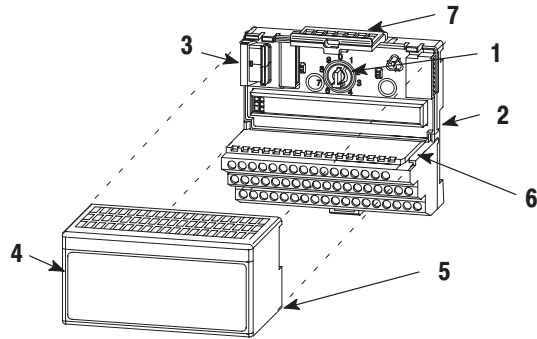

Installation Instructions

220V ac FLEX I/O 8 Input Module (Cat. No. 1794-IM8)



Module Installation

This module mounts on a 1794 terminal base unit.

1. Rotate keyswitch (1) on terminal base unit (2) clockwise to position 8 as required for this type of module.
2. Make certain the flexbus connector (3) is pushed all the way to the left to connect with the neighboring terminal base/adaptor. **You cannot install the module unless the connector is fully extended.**
3. Make sure that the pins on the bottom of the module are straight so they will align properly with the connector in the terminal base unit.

WARNING



If you remove or insert the module while the backplane power is on, an electrical arc can occur. This could cause an explosion in hazardous location installations. Be sure that power is removed or the area is nonhazardous before proceeding.

4. Position the module (4) with its alignment bar (5) aligned with the groove (6) on the terminal base.

5. Press firmly and evenly to seat the module in the terminal base unit. The module is seated when the latching mechanism (7) is locked into the module.

ATTENTION



To use this module in a complementary I/O system, refer to your Remote I/O Adapter module documentation.

Important User Information

Because of the variety of uses for the products described in this publication, those responsible for the application and use of these products must satisfy themselves that all necessary steps have been taken to assure that each application and use meets all performance and safety requirements, including any applicable laws, regulations, codes and standards. In no event will Rockwell Automation be responsible or liable for indirect or consequential damage resulting from the use or application of these products.

Any illustrations, charts, sample programs, and layout examples shown in this publication are intended solely for purposes of example. Since there are many variables and requirements associated with any particular installation, Rockwell Automation does not assume responsibility or liability (to include intellectual property liability) for actual use based upon the examples shown in this publication.

Allen-Bradley publication SGI-1.1, Safety Guidelines for Application, Installation, and Maintenance of Solid-State Control (available from your local Rockwell Automation office), describes some important differences between solid-state equipment and electromechanical devices that should be taken into consideration when applying products such as those described in this publication.

Reproduction of the contents of this copyrighted publication, in whole or part, without written permission of Rockwell Automation, is prohibited.

Throughout this publication, notes may be used to make you aware of safety considerations. The following annotations and their accompanying statements help you to identify a potential hazard, avoid a potential hazard, and recognize the consequences of a potential hazard.

WARNING



Identifies information about practices or circumstances that can cause an explosion in a hazardous environment, which may lead to personal injury or death, property damage, or economic loss.

ATTENTION



Identifies information about practices or circumstances that can lead to personal injury or death, property damage, or economic loss.

IMPORTANT

Identifies information that is critical for successful application and understanding of the product.

ATTENTION



Environment and Enclosure

This equipment is intended for use in a Pollution Degree 2 industrial environment, in overvoltage Category II applications (as defined in IEC publication 60664–1), at altitudes up to 2000 meters without derating.

This equipment is considered Group 1, Class A industrial equipment according to IEC/CISPR Publication 11. Without appropriate precautions, there may be potential difficulties ensuring electromagnetic compatibility in other environments due to conducted as well as radiated disturbance.

This equipment is supplied as “open type” equipment. It must be mounted within an enclosure that is suitably designed for those specific environmental conditions that will be present, and appropriately designed to prevent personal injury resulting from accessibility to live parts. The interior of the enclosure must be accessible only by the use of a tool. Subsequent sections of this publication may contain additional information regarding specific enclosure type ratings that are required to comply with certain product safety certifications.

See NEMA Standards publication 250 and IEC publication 60529, as applicable, for explanations of the degrees of protection provided by different types of enclosures. Also, see the appropriate sections in this publication, as well as the Allen–Bradley publication 1770–4.1, (“Industrial Automation Wiring and Grounding Guidelines”), for additional installation requirements pertaining to this equipment.

ATTENTION



FLEX I/O is grounded through the DIN rail to chassis ground. Use zinc plated, yellow chromated steel DIN rail to assure proper grounding. Using other DIN rail materials (e.g. aluminum, plastic, etc.) which can corrode, oxidize or are poor conductors can result in improper or intermittent platform grounding.

ATTENTION



Preventing Electrostatic Discharge

This equipment is sensitive to electrostatic discharge, which can cause internal damage and affect normal operation. Follow these guidelines when you handle this equipment:

- Touch a grounded object to discharge potential static.
 - Wear an approved grounding wriststrap.
 - Do not touch connectors or pins on component boards.
 - Do not touch circuit components inside the equipment.
 - If available, use a static-safe workstation.
 - When not in use, keep modules in appropriate static-safe packaging.
-

ATTENTION



Remove field-side power before removing or inserting this module. This module is designed so you can **remove and insert it under backplane power**. When you remove or insert a module with field-side power applied, an electrical arc may occur. An electrical arc can cause personal injury or property damage by:

- sending an erroneous signal to your system's field devices causing unintended machine motion
- causing an explosion in a hazardous environment

Repeated electrical arcing causes excessive wear to contacts on both the module and its mating connector. Worn contacts may create electrical resistance.

Wiring to a 1794-TBN Terminal Base Unit

WARNING



If you connect or disconnect wiring while the field side power is on, an electrical arc can occur. This could cause an explosion in hazardous location installations. Be sure that power is removed or the area is nonhazardous before proceeding.

1. Connect individual input wiring to the even numbered terminals on row (B) as indicated in the table below.
2. Connect the associated input wiring to the corresponding odd numbered terminal on row (C) for each input as indicated in the table below.
3. Connect 220V ac (L1) to terminal 34 on row (C).
4. Connect 220V ac common (L2) to terminal 16 on row (B).
5. If continuing power to the next terminal base unit, connect a jumper from terminal 51 (220V ac L1) on this base unit to terminal 34 on the next base unit.
6. If continuing common to the next terminal base unit, connect a jumper from terminal 33 (220V ac common L2) on this base unit to terminal 16 on the next base unit.

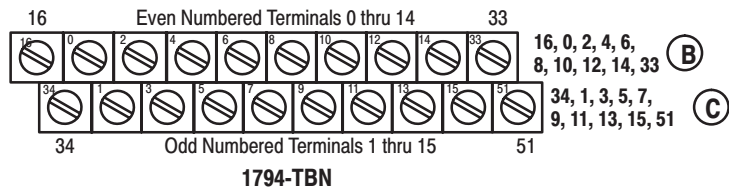

Channel	1794-TBN	
	Input Terminals	220V ac Supply
0	B-0	C-1 ¹
1	B-2	C-3 ¹
2	B-4	C-5 ¹
3	B-6	C-7 ¹
4	B-8	C-9 ¹
5	B-10	C-11 ¹
6	B-12	C-13 ¹
7	B-14	C-15 ¹

B = even numbered terminals 0 thru 14, ac common terminals 16 and 33
 C = Power terminals C-34 and 51, and odd numbered input terminals 1 thru 15

¹ C-1, 3, 5, 7, 9, 11, 13 and 15 are internally connected in the module to 220V ac L1.

ATTENTION



Total current draw through the terminal base unit is limited to 10A. Separate power connections to the terminal base unit may be necessary.

Indicators

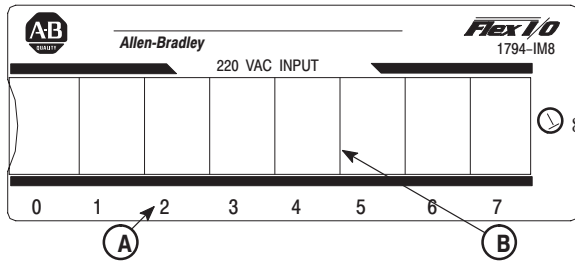

A = Status Indicators – yellow – show status of individual inputs.

B = Insertable label for writing individual input designations.

Image Table Memory Map

Image Table	Dec. Bits (Oct. Bits)	Description	Format
Input	00-07	Status of input data	0-7
	08-15 (10-17)	Not used	
Output	00-02	Delay time for Inputs 0 to 7	
	03-15 (3-17)	Not used	

Dec.	15	14	13	12	11	10	09	08	07	06	05	04	03	02	01	00
(Oct.)	17	16	15	14	13	12	11	10	07	06	05	04	03	02	01	00
read	Not used – set to 0								I7	I6	I5	I4	I3	I2	I1	I0
write	Not used – set to 0													D	D	D

Where: I = Input number
D = Delay time bit – see below

Increasing the Input Delay Time

You can increase the input delay time (DT) for channels 00 through 07. Select the input delay time by setting the corresponding bits in the **output** image table (complementary word) for the module.

For example, to increase the off-to-on delay time to 10ms for an ac input module at address rack 1, module group 0, set bits 02, 01, and 00 as shown below.

15	14	13	12	11	10	09	08	07	06	05	04	03	02	01	00	Dec. (Octal) = 3 Octal or 3 Decimal
17	16	15	14	13	12	11	10	07	06	05	04	03	02	01	00	
													0	1	1	

DT = 00-07

Write Delay Time on system startup.



Write DT to complement of input module.

Delay Times

Bits			Description	Maximum Delay Time	
02	01	00		Off to On	On to Off
0	0	0	Delay Time 0 (default)	7.5ms	26.5ms
0	0	1	Delay Time 1	8ms	27ms
0	1	0	Delay Time 2	9ms	28ms
0	1	1	Delay Time 3	10ms	29ms
1	0	0	Delay Time 4	12ms	31ms
1	0	1	Delay Time 5	16ms	35ms
1	1	0	Delay Time 6	24.5ms	44ms
1	1	1	Delay Time 7	42ms	60.5ms

The following information applies when operating this equipment in hazardous locations:

Products marked "CL I, DIV 2, GP A, B, C, D" are suitable for use in Class I Division 2 Groups A, B, C, and D Hazardous Locations and nonhazardous locations only. Each product is supplied with markings on the rating nameplate indicating the hazardous location temperature code. When combining products within a system, the most adverse temperature code (lowest "T" number) may be used to help determine the overall temperature code of the system. Combinations of equipment in your system are subject to investigation by the local Authority Having Jurisdiction at the time of installation.

WARNING



EXPLOSION HAZARD -

- Do not disconnect equipment unless power has been removed or the area is known to be nonhazardous.
- Do not disconnect connections to this equipment unless power has been removed or the area is known to be nonhazardous. Secure any external connections that mate to this equipment by using screws, sliding latches, threaded connectors, or other means provided with this product.
- Substitution of components may impair suitability for Class I, Division 2.
- If this product contains batteries, they must only be changed in an area known to be nonhazardous.

Informations sur l'utilisation de cet équipement en environnements dangereux:

Les produits marqués CL I, DIV 2, GP A, B, C, D ne conviennent que une utilisation en environnements de Classe I Division 2 Groupes A, B, C, D dangereux et non dangereux. Chaque produit est livré avec des marquages sur sa plaque d'identification qui indiquent le code de température pour les environnements dangereux. Lorsque plusieurs produits sont combinés dans un système, le code de température le plus défavorable (code de température le plus faible) peut être utilisé pour déterminer le code de température global du système. Les combinaisons d'équipements dans le système sont sujettes à inspection par les autorités locales qualifiées au moment de l'installation.

AVERTISSEMENT



RISQUE D'EXPLOSION -

- Couper le courant ou s'assurer que l'environnement est classé non dangereux avant de débrancher l'équipement.
- Couper le courant ou s'assurer que l'environnement est classé non dangereux avant de débrancher les connecteurs. Fixer tous les connecteurs externes reliés à cet équipement à l'aide de vis, loquets coulissants, connecteurs filetés ou autres moyens fournis avec ce produit.
- La substitution de composants peut rendre cet équipement inadapté à une utilisation en environnement de Classe 1, Division 2.
- S'assurer que l'environnement est classé non dangereux avant de changer les piles.

10 220V ac FLEX I/O 8 Input Module

Specifications – 220V ac Input Module Cat. No. 1794-IM8	
Number of Inputs	8 (1 group of 8), non-isolated
Module Location	Cat. No. 1794-TBN Terminal Base Unit
Module Mounting	See Derating Curve below.
Minimum ON-state Voltage	159V ac
ON-state Current	Minimum Normal Maximum
	5.27mA @ 159V ac, 47Hz 9.88mA @ 220V ac, 60Hz 13.21mA @ 264V ac, 63Hz
Maximum OFF-state Voltage	40V ac
Maximum OFF-state Current	2.6mA
Nominal Input Impedance	22.3K ohms
Nominal Input Current	10mA @ 220V ac, 60Hz
Isolation	
Channel to channel	None required
Customer power to input channels	None
User to system	100% tested at 2600V dc for 1s
Input DelayTime (maximum)	
Off to On (time from a valid input signal to recognition by block)	7.5ms, 8ms, 9ms, 10ms, 12ms, 16ms, 24.5ms, 42ms
On to Off (time from input dropping below valid level to recognition by block)	26.5ms, 27ms, 28ms, 29ms, 31ms, 35ms, 44ms, 60.5ms
	Delay time selectable thru output image table Default is 7.5ms off to on/26.5ms on to off
Flexbus Current (maximum)	30mA @ 5V dc
Power Dissipation	Maximum 4.7W @ 264V ac
Thermal Dissipation	Maximum 16.2 BTU/hr @ 264V ac
Indicators (field side indication, customer device driven)	8 yellow status indicators
Keyswitch Position	8
Specifications continued on next page.	

Specifications – 220V ac Input Module Cat. No. 1794-IM8**General Specifications**

External ac Power Supply Voltage Voltage Range	220V ac nominal 159 to 264V ac, 47-63Hz (See Derating Curve below.)
Dimensions Inches (Millimeters)	1.8H x 3.7W x 2.1D (45.7 x 94.0 x 53.3)
Environmental Conditions Operating Temperature	IEC 60068-2-1 (Test Ad, Operating Cold) IEC 60068-2-2 (Test Bd, Operating Dry Heat) IEC 60068-2-14 (Test Nb, Operating Thermal Shock) 32 to 131°F (0° to 55°C)
Storage Temperature	IEC 60068-2-1 (Test Ab, Unpackaged, Nonoperating Cold) IEC 60068-2-2 (Test Bb, Unpackaged, Nonoperating Dry Heat) IEC 60068-2-14 (Test Na, Unpackaged, Nonoperating Thermal Shock) -40 to 185°F (-40 to 85°C)
Relative Humidity	IEC 60068-2-30 (Test Db, Unpackaged, Nonoperating Damp Heat) 5 to 95%, noncondensing
Shock Operating Nonoperating	IEC 60068-2-27 (Test Ea, Unpackaged Shock) 30g 50g
Vibration	IEC 60068-2-6 (Test Fc, Operating) 5g @ 10-500Hz
ESD Immunity	IEC 61000-4-2 4kV contact discharges 8kV air discharges
Radiated RF Immunity	IEC 61000-4-3 10V/m with 1kHz sine-wave 80% AM from 30MHz to 1000MHz
EFT/B Immunity	IEC 61000-4-4 ±2kV @ 5kHz on signal ports

Specifications – 220V ac Input Module Cat. No. 1794-IM8

Surge Transient Immunity	IEC 61000-4-5 ±1kV line-line (DM) and ±2kV line-earth (CM) on signal ports
Conducted RF Immunity	IEC 61000-4-6 10V rms with 1kHz sine wave 80% AM from 150kHz to 80MHz
Emissions	CISPR 11 Group 1, Class A (with appropriate enclosure)
Enclosure Type Rating	None (open-style)
Terminal Base Screw Torque	7 pound-inches (0.6Nm)
Conductors	12 gauge (4mm ²) maximum stranded copper rated at 60°C or greater 3/64 inch (1.2mm) insulation maximum 1 ¹
Wire Size	
Category	

Specifications continued on next page.

Specifications – 220V ac Input Module Cat. No. 1794-IM8

Certifications (when product is marked)	UL	UL Listed Industrial Control Equipment
	CSA	CSA Certified Process Control Equipment
	CSA	CSA Certified Process Control Equipment for Class I, Division 2 Group A, B, C, D Hazardous Locations
	EEx ²	European Union 94/9/EEC ATEX Directive, compliant with EN 50021; Potentially Explosive Atmospheres, Protection “n”
	CE ²	European Union 89/336/EEC EMC Directive, compliant with: EN 61000-6-4, Industrial Emissions EN 50082-2, Industrial Immunity EN 61326, Meas./Control/Lab., Industrial Requirements EN 61000-6-2, Industrial Immunity
	CE ²	European Union 73/23/EEC LVD Directive, compliant with: EN 61131-2, Programmable Controllers
C-Tick ²	Australian Radiocommunications Act, compliant with: AS/NZS 2064, Industrial Emissions	

¹ You use this conductor category information for planning conductor routing. Refer to publication 1770-4.1, “Industrial Automation Wiring and Grounding Guidelines for Noise Immunity.”

² See the Product Certification link at www.ab.com for Declarations of Conformity, Certificates and other certification details

European Zone 2 Certification

This equipment is intended for use in potentially explosive atmospheres as defined by European Union Directive 94/9/EC.

The LCIE (Laboratoire Central des Industries Electriques) certifies that this equipment has been found to comply with the Essential Health and Safety Requirements relating to the design and construction of Category 3 equipment intended for use in potentially explosive atmospheres, given in Annex II to this Directive. The examination and test results are recorded in confidential report No. 28 682 010.

Compliance with the Essential Health and Safety Requirements has been assured by compliance with EN 50021 (1999).

IMPORTANT

Observe the following additional Zone 2 certification requirements:

- This equipment is not resistant to sunlight or other sources of UV radiation.
 - The secondary of a current transformer shall not be open-circuited when applied in Class I, Zone 2 environments.
 - Equipment of lesser Enclosure Type Rating must be installed in an enclosure providing at least IP54 protection when applied in Class I, Zone 2 environments.
 - This equipment shall be used within its specified ratings defined by Allen-Bradley.
 - Provision shall be made to prevent the rated voltage from being exceeded by transient disturbances of more than 40% when applied in Class I, Zone 2 environments.
-

Derating Curve

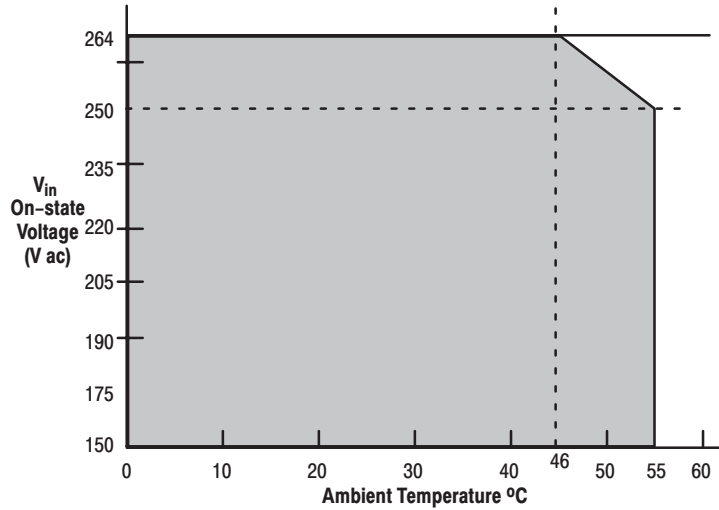

The area within the curve represents the safe operating range for the module under various conditions of user supplied 220V ac supply voltages and ambient temperatures.

 = All mounting positions (including normal horizontal, vertical, inverted horizontal) safe operating range

Voltage (maximum)	Temperature (maximum)
264	46
250	55



With major offices worldwide. 

World Headquarters,
Allen-Bradley,
1201 South Second Street,
Milwaukee, WI 53204 USA,
Tel: (1) 414 382-2000 Fax: (1) 414 382-4444