

## Optical Transceiver

1785-TR10BF

The optical transceiver enables a device with an AUI interface to connect to a 10 Mbit/s CSMA/CD LAN (ISO/IEC 8802-3, IEEE 802.3, 10BASE-FL) via a fiber optic cable.

- monitoring LEDs for
  - link status
  - RxData
  - collision/jabber control
  - TxData
  - power
- SQE test can be disabled externally
- can be plugged directly to the device interface
- low current consumption
- compact construction

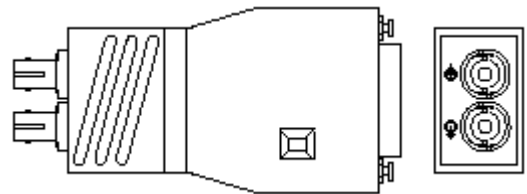

### To the Installer

Topic	Page
Description	2
Installation	3
Compliance to European Union Directives	4
Technical Data	7

**Description**

The 1785-TR10BF mini optical transceiver can be connected to the AUI interface of a device either directly or via an AUI cable. It is connected to the fiber optic cable by a BFOC socket.

The 1785-TR10BF mini optical transceiver offers these functions according to IEEE 802.3 10BASE-FL:

- indication via LEDs of data transmission and reception through the fiber optic cable
- detection of data collisions in the network and reporting them to the terminal equipment as well as indicating them by an LED
- ability to enable/disable the SQE test: at the end of every transmit operation, a short collision signal (heart beat) approx. 1  $\mu$ s long is sent to monitor the electronics
- jabber control and display: protect the network from data packets that are too long (> 70 ms)
- link status: an IDLE signal continuously monitors the fiber optic cable segment for breakage

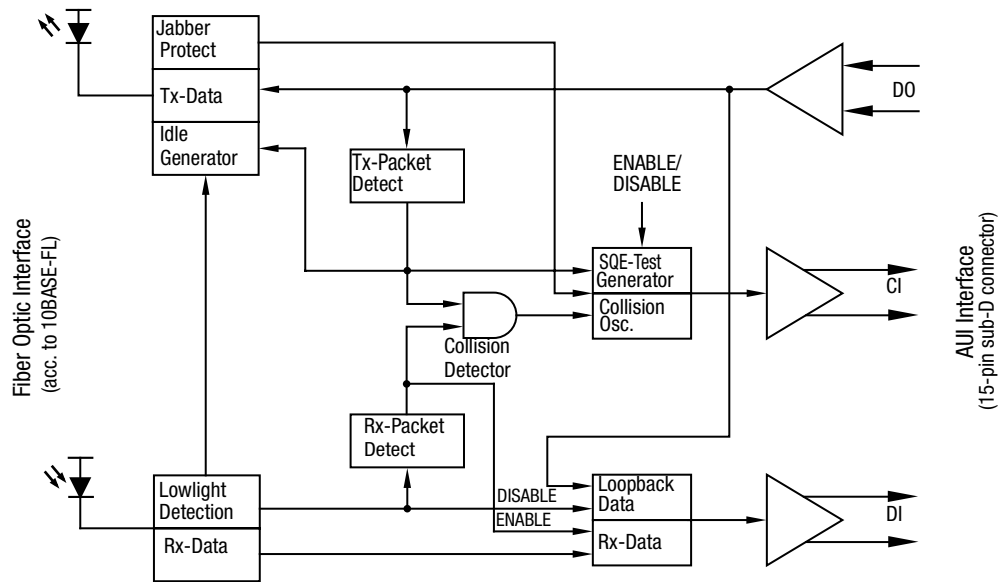

## Installation

### Fiber Optic Connection

Two BFOC sockets are available for connecting the 1785-TR10BF transceiver to a fiber optic segment. One connection is used for transmitting and one for receiving data over the fiber optic cable.

The maximum length of the fiber optic segment is

- 2000 m for 50/125 fiber
- 3000 m for 62.5/125 fiber

### Power Supply

The operating voltage (+12 V) is taken from the connected device via the 15-pin sub-D socket of the AUI interface.

### SQE Test Setting

The slide switch on the top of the transceiver case is used to activate and deactivate the SQE test. Before placing the transceiver in operation, you should check to see whether the connected device requires the SQE test to be on or off. As delivered from the factory, the SQE test is on.

### Connecting Devices

#### Connecting two devices

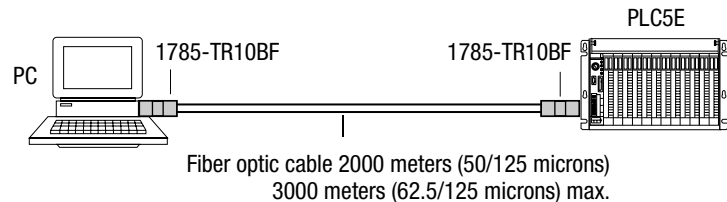

#### Connecting to a fiber optic interface hub

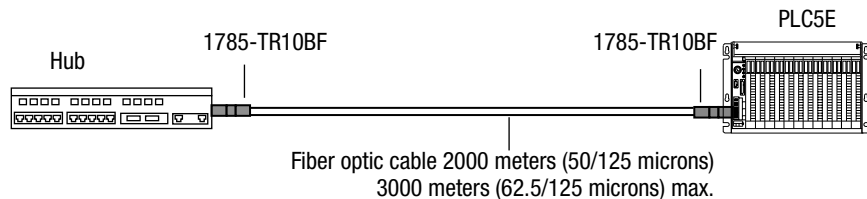

### For Additional Information

For standards information, go to <http://www.ieee.org/>. To download a .PDF copy of this publication, go to <http://www.theautomationbookstore.com/>.

## Compliance to European Union Directives

If this product has the **CE** marking, it is approved for installation within the European Union and EEA regions. It has been designed and tested to meet the following directives.

### EMC Directive

This product is tested to meet Council Directive 89/336/EEC Electromagnetic Compatibility (EMC) and the following standards, in whole or in part, documented in a technical construction file:

- EN 50081-2 EMC - Generic Emission Standard, Part 2 - Industrial Environment
- EN 50082-2 EMC - Generic Immunity Standard, Part 2 - Industrial Environment

This product is intended for use in an industrial environment.

### Low Voltage Directive

This product is tested to meet Council Directive 73/23/EEC Low Voltage, by applying the safety requirements of EN 60950 - Information Technology Equipment.

For specific information required by EN 60950, see the appropriate sections in this publication, as well as the following Allen-Bradley publications:

- Industrial Automation Wiring and Grounding Guidelines for Noise Immunity, publication 1770-4.1
- Automation Systems Catalog, publication B111

### Hazardous Location Approval

This product may be certified for general use as well as for use in hazardous locations. **Actual agency certification is indicated by the product label** as shown below, and not by statements in any user documentation.

Example of the certification product label:

CL I, DIV 2  
GP A,B,C,D  
TEMP



To comply with certification for use in hazardous locations, the following information becomes a part of the product literature for this certified industrial control product.

- This equipment is suitable for use in Class I, Division 2, Groups A, B, C, D, or non-hazardous locations only.
- The products having the appropriate markings (that is, Class I, Division 2, Groups A, B, C, D) are certified for use in other equipment where the suitability of combination (that is, application or use) is determined by the local authority having jurisdiction.

**Important:** Due to the modular nature of a programmable control system, the product with the highest temperature rating determines the overall temperature code rating of a programmable control system in a Class I, Division 2, location. The temperature code rating is marked on the product label as shown.

Temperature code rating:

CL I, DIV 2  
GP A,B,C,D  
TEMP



Look for temperature  
code rating here.

The following warnings apply to products having certification for use in hazardous locations.



#### **ATTENTION:** Explosion hazard -

- Substitution of components may impair suitability for Class I, Division 2.
- Do not replace components unless power has been switched off or the area is known to be non-hazardous.
- Do not disconnect equipment unless power has been switched off or the area is known to be non-hazardous.
- Do not disconnect connectors unless power has been switched off or the area is known to be non-hazardous. Secure any user-supplied connectors that mate to external circuits on this equipment by using screws, sliding latches, threaded connectors, or other means such that any connection can withstand a 15 Newton (3.4 lb.) separating force applied for a minimum of one minute.

### Approbation d'utilisation en environnements dangereux

Ce produit est certifié pour une utilisation générale aussi bien que pour une utilisation en environnements dangereux. **La certification en vigueur est indiquée par l'étiquette produit** et non par des indications dans la documentation utilisateur.

Exemple d'étiquette de certification d'un produit :

CL I, DIV 2  
GP A,B,C,D  
TEMP



Pour satisfaire à la certification en environnements dangereux, les informations suivantes font partie intégrante de la documentation des produits de commande industrielle certifiés.

- Cet équipement ne convient qu'à une utilisation en environnements de Classe 1, Division 2, Groupes A, B, C, D, ou non dangereux.
- Les produits portant le marquage approprié (c'est-à-dire, Classe 1, Division 2, Groupes A, B, C, D) sont certifiés pour une utilisation avec d'autres équipements, les combinaisons d'applications et d'utilisation étant déterminées par le bureau local d'inspection qualifié.

**Important :** De par la nature modulaire des systèmes de commande programmables, le produit ayant le code de température le plus élevé détermine le code de température global du système dans un environnement de Classe 1, Division 2. Le code de température est indiqué sur l'étiquette produit.

Code de température :

CL I, DIV 2  
GP A,B,C,D  
TEMP



Le code de température  
est indiqué ici

Les avertissements suivants s'appliquent aux produits certifiés pour une utilisation en environnements dangereux.





#### **DANGER :** Risque d'explosion

- La substitution de composants peut rendre cet équipement inadapté à une utilisation en environnement de Classe 1, Division 2.
- Couper le courant ou s'assurer que l'environnement est classé non dangereux avant de remplacer des composants.
- Couper le courant ou s'assurer que l'environnement est classé non dangereux avant de débrancher l'équipement.
- Couper le courant ou s'assurer que l'environnement est classé non dangereux avant de débrancher les connecteurs. Fixer tous les connecteurs fournis par l'utilisateur pour se brancher aux circuits externes de cet équipement à l'aide de vis, loquets coulissants, connecteurs filetés ou autres, de sorte que les connexions résistent à une force de séparation de 15 newtons (1,5 kg - 3,4 lb) appliquée pendant au moins une minute.

## Technical Data

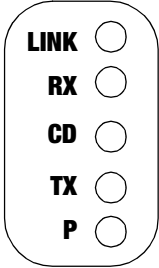
<b>Transceiver interface (AUI)</b>	
Operating voltage	+12 V
Current consumption (no signal)	200 mA
Bit rate (Manchester Code)	10 Mbit/s
Dimensions W x H x D	44 mm x 22 mm x 91 mm (1.8 in. x .83 in. x 3.6 in.)
Weight	130 g
Ambient temperature	0° C to +50° C
Storage temperature	-20° C to +80° C
Relative humidity	10 % to 90 % (non-condensing)
<b>Fiber optic interface: Transmitter</b>	
Light source	LED
Wave length	820 nm
Minimum peak optical power [in dBm/ $\mu$ W] fed into the fiber optic cable	
50/125	-19/ 12.6
62.5/125	-16/ 25
Fiber type	gradient
IDLE-Signal	1 MHz $\pm$ 10%
Preamble loss transmit	typ. 1 bit; max. 2 bit
Steady state delay	20 ns
Jabber protect time out	70 ms
Jabber reset	450 ms
<b>Fiber optic interface: Receiver</b>	
Photo detector	PIN diode
Optical input power	> -31 dBm (0.8 $\mu$ W)
Bit error rate (1 $\mu$ W)	< 10 <sup>-9</sup>
Low light threshold	-30 dBm (1 $\mu$ W)
Saturation limit	$\geq$ -9 dBm
Preamble loss receive	typ. 1 bit; max. 3 bit
Steady state delay	20 ns
Collision detection time (Data in $\rightarrow$ SQE out)	max. 350 ns
<b>Input:</b>	
Termination resistor	78 $\Omega$ $\pm$ 1%
Sensitivity	500 mVPP
Maximum DC component	$\pm$ 50 V
<b>Output:</b>	
Output voltage (data and CD signal)	1,6 VPP
CD signal frequency	10 MHz $\pm$ 10%
SQE Test (heartbeat)	can be disabled
delay time	1100 ns
length	1000 ns
AUI cable length	0 to 50 m max.

<b>Connection capabilities</b>	
Transceiver interface	plugged directly on to the AUI interface of connected device or connected by an AUI cable (50 m max. length)
Fiber optic interface	Fiber optic cable segment maximum 2000 m (50/125 microns) or 3000 m (62.5/125 microns) long
<b>Connections with pin assignments</b>	
Transceiver interface (15-pin sub-D plug)	Input:DO-A: pin 3; DO-B: pin 10 Output:DI-A: pin 5; DI-B: pin 12 Collision detect:CI-A: pin 2; CI-B: pin 9 Power:GND: pin 6; +12 V: pin 13 Shielding:pin 1, 4, 8, 11, 14
Fiber optic interface	2 x IEC 874-10 BFOC/2.5 sockets
Displays	 <ul style="list-style-type: none"> <li>* green LED: LINK (link status) on - fiber optic connection OK</li> <li>* yellow LED: RX (Rx data) on - data being received over fiber optic cable link</li> <li>* red LED: CD (collision detect) brief flash – data collision continuously on – jabber control active</li> <li>* yellow LED: TX (Tx data) on - data being transmitted through fiber optic cable link</li> <li>* green LED: P (power) on – supply voltage present</li> </ul>
Conductors/Wire Size/Category	Category 1 <sup>1</sup>
Agency Certification (when product is marked)	 <ul style="list-style-type: none"> <li>• Information Technology Equipment</li> <li>• Industrial Control Equipment</li> <li>• Class I, Div. 2, Groups A, B, C, D Hazardous Location</li> </ul> <p>CE</p> <ul style="list-style-type: none"> <li>• EN 50082-1, 2</li> <li>• EN 55022, Radiated Emission Class B</li> <li>• EN 60950</li> </ul> <p>FCC Part 15, SubPart B</p>

<sup>1</sup> Refer to the Industrial Automation Wiring and Grounding Guidelines for Noise Immunity, publication 1770-4.1.

[www.rockwellautomation.com](http://www.rockwellautomation.com)

### Power, Control and Information Solutions Headquarters

Americas: Rockwell Automation, 1201 South Second Street, Milwaukee, WI 53204-2496 USA, Tel: (1) 414.382.2000, Fax: (1) 414.382.4444

Europe/Middle East/Africa: Rockwell Automation, Vorstlaan/Boulevard du Souverain 36, 1170 Brussels, Belgium, Tel: (32) 2 663 0600, Fax: (32) 2 663 0640

Asia Pacific: Rockwell Automation, Level 14, Core F, Cyberport 3, 100 Cyberport Road, Hong Kong, Tel: (852) 2887 4788, Fax: (852) 2508 1846

Publication 1785-5.19 - January 1999

PN 955134-73

Copyright 1999 of Rockwell International Corporation. Printed in the U.S.A.