

## Coax Transceiver for 10BASE5

Catalog Number 1785-TR10B5

The coax transceiver lets you connect a device with an AUI interface to a 10 Mbit/s CSMA/CD LAN (ISO/IEC 8802-3, IEEE 802.3, 10BASE5) coax cable connection via this cable piercing tap.

- Monitoring LEDs for
  - power
  - collision/jabber control
  - data
- SQE test can be disabled externally
- Compact construction

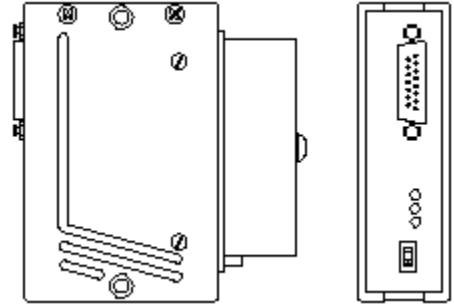

### To the Installer

Topic	Page
Description	1
Installation	2
Coupling the Transceivers with the Coax Cable (10BASE5)	2
Compliance to European Union Directives	4
Technical Data	7

### Description

The 1785-TR10B5 coax transceiver can be connected to the AUI interface of a device either directly or via an AUI cable. It is connected to the coax cable by a coax interface.

The transceiver offers these functions according to IEEE 802.3 10BASE5:

- receiving the data at the transceiver interface and sending them into the coax cable
- receiving the data from the coax cable and sending them to the transceiver interface
- indication via a yellow LED of data transmission and reception through the coax cable
- detection of data collisions in the network and reporting them to the terminal equipment as well as indicating them by a red LED
- ability to enable/disable the SQE test: at the end of every transmit operation, a short collision signal (heart beat) approx. 1  $\mu$ s long is sent to monitor the electronics
- jabber control and display: protecting the network from data packets that are too long (> 20 ms)

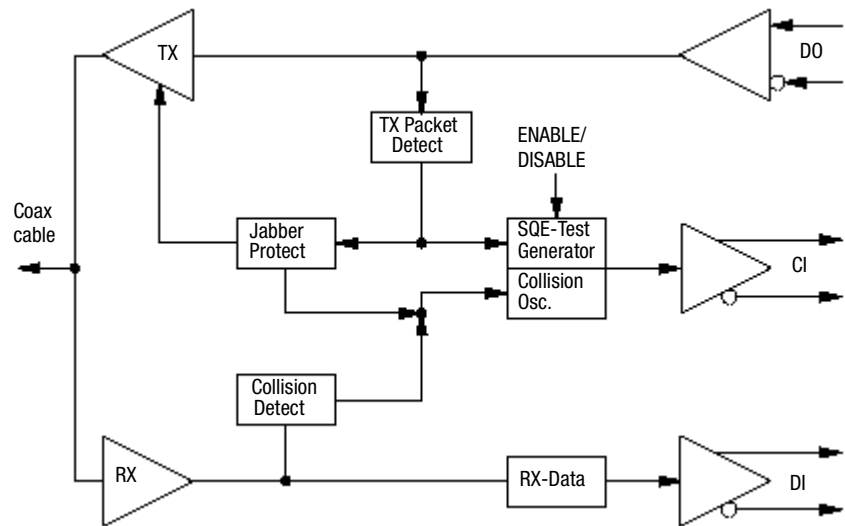

## Installation

### SQE Test

The slide switch located beside the three control LEDs is used to activate and deactivate the SQE test.

**Important:** Before placing the transceiver in operation, you should check to see whether the connected device requires the SQE test to be on or off.

### Power Supply

The operating voltage (+12 V) is taken from the connected device via the 15-pin Sub-D socket of the AUI interface.

## Coupling the Transceivers with the Coax Cable (10BASE5)

### 1785-TR10B5 with cable piercing tap

The vampire terminal consists of these single items:

- 1 top section
- 1 socket-head cap screw
- 1 bottom section
- 2 contact springs
- 1 contact needle



The distance between two transceivers fitted on the same coax segment must be at least 2.5 meters.

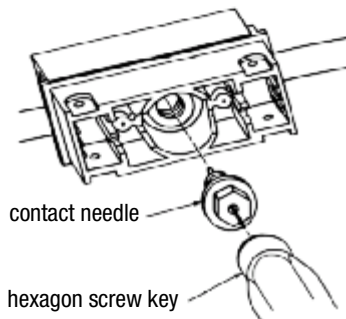
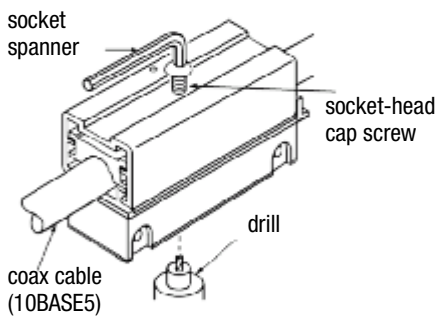
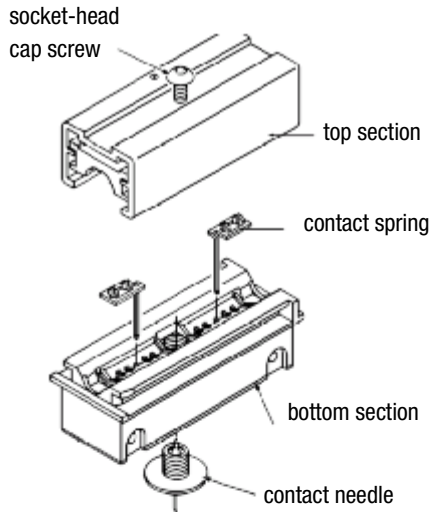

## Assembly

1. As shown in the figure, insert the two contact springs in the bottom part. Do not screw in the contact needle.
2. Determine the required coupling point on the coax cable.
3. Place the coax cable in the bottom section.
4. Push the top section onto the bottom section.
5. Screw the socket-head cap screw into the top section using the socket spanner, and tighten it.
6. Drill into the cable with the drill of the combination tool.

### Important: Drill cleanly, i.e.:

- no protruding wires of the cable shield visible in the drill hole (risk of short-circuit)
  - drill hole penetrates the braiding and foil of the shield so that the dielectric of the cable (plastic layer between centre conductor and shield) is visible
7. If it is not possible to drill deeply enough, tighten the socket-head cap screw further.

### Important: Tighten the screw gently!

8. Screw in the contact needle using the hexagon screw key of the combination tool.
9. Insert the pre-assembled vampire terminal in the housing of the 1785-TR10B5 until it bottoms and secure it with the M3 screws included.

## For Additional Information

For standards information, go to <http://www.ieee.org/>. To download a .PDF copy of this publication, go to <http://www.theautomationbookstore.com/>.

## Compliance to European Union Directives

If this product has the **CE** marking, it is approved for installation within the European Union and EEA regions. It has been designed and tested to meet the following directives.

### EMC Directive

This product is tested to meet Council Directive 89/336/EEC Electromagnetic Compatibility (EMC) and the following standards, in whole or in part, documented in a technical construction file:

- EN 50081-2 EMC - Generic Emission Standard, Part 2 - Industrial Environment
- EN 50082-2 EMC - Generic Immunity Standard, Part 2 - Industrial Environment

This product is intended for use in an industrial environment.

### Low Voltage Directive

This product is tested to meet Council Directive 73/23/EEC Low Voltage, by applying the safety requirements of EN 60950 - Information Technology Equipment.

For specific information required by EN 60950, see the appropriate sections in this publication, as well as the following Allen-Bradley publications:

- Industrial Automation Wiring and Grounding Guidelines for Noise Immunity, publication 1770-4.1
- Automation Systems Catalog, publication B111

### Hazardous Location Approval

This product may be certified for general use as well as for use in hazardous locations. **Actual agency certification is indicated by the product label** as shown below, and not by statements in any user documentation.

Example of the certification product label:

CL I, DIV 2  
GP A,B,C,D  
TEMP



To comply with certification for use in hazardous locations, the following information becomes a part of the product literature for this certified industrial control product.

- This equipment is suitable for use in Class I, Division 2, Groups A, B, C, D, or non-hazardous locations only.
- The products having the appropriate markings (that is, Class I, Division 2, Groups A, B, C, D) are certified for use in other equipment where the suitability of combination (that is, application or use) is determined by the local authority having jurisdiction.

**Important:** Due to the modular nature of a programmable control system, the product with the highest temperature rating determines the overall temperature code rating of a programmable control system in a Class I, Division 2, location. The temperature code rating is marked on the product label as shown.

Temperature code rating:

CL I, DIV 2  
GP A,B,C,D  
TEMP



Look for temperature  
code rating here.

The following warnings apply to products having certification for use in hazardous locations.



#### **ATTENTION:** Explosion hazard -

- Substitution of components may impair suitability for Class I, Division 2.
- Do not replace components unless power has been switched off or the area is known to be non-hazardous.
- Do not disconnect equipment unless power has been switched off or the area is known to be non-hazardous.
- Do not disconnect connectors unless power has been switched off or the area is known to be non-hazardous. Secure any user-supplied connectors that mate to external circuits on this equipment by using screws, sliding latches, threaded connectors, or other means such that any connection can withstand a 15 Newton (3.4 lb.) separating force applied for a minimum of one minute.

### Approbation d'utilisation en environnements dangereux

Ce produit est certifié pour une utilisation générale aussi bien que pour une utilisation en environnements dangereux. **La certification en vigueur est indiquée par l'étiquette produit** et non par des indications dans la documentation utilisateur.

Exemple d'étiquette de certification d'un produit :

CL I, DIV 2  
GP A,B,C,D  
TEMP

Pour satisfaire à la certification en environnements dangereux, les informations suivantes font partie intégrante de la documentation des produits de commande industrielle certifiés.

- Cet équipement ne convient qu'à une utilisation en environnements de Classe 1, Division 2, Groupes A, B, C, D, ou non dangereux.
- Les produits portant le marquage approprié (c'est-à-dire, Classe 1, Division 2, Groupes A, B, C, D) sont certifiés pour une utilisation avec d'autres équipements, les combinaisons d'applications et d'utilisation étant déterminées par le bureau local d'inspection qualifié.

**Important :** De par la nature modulaire des systèmes de commande programmables, le produit ayant le code de température le plus élevé détermine le code de température global du système dans un environnement de Classe 1, Division 2. Le code de température est indiqué sur l'étiquette produit.

Code de température :

CL I, DIV 2  
GP A,B,C,D  
TEMP

Le code de température  
est indiqué ici

Les avertissements suivants s'appliquent aux produits certifiés pour une utilisation en environnements dangereux.





#### **DANGER :** Risque d'explosion

- La substitution de composants peut rendre cet équipement inadapté à une utilisation en environnement de Classe 1, Division 2.
- Couper le courant ou s'assurer que l'environnement est classé non dangereux avant de remplacer des composants.
- Couper le courant ou s'assurer que l'environnement est classé non dangereux avant de débrancher l'équipement.
- Couper le courant ou s'assurer que l'environnement est classé non dangereux avant de débrancher les connecteurs. Fixer tous les connecteurs fournis par l'utilisateur pour se brancher aux circuits externes de cet équipement à l'aide de vis, loquets coulissants, connecteurs filetés ou autres, de sorte que les connexions résistent à une force de séparation de 15 newtons (1,5 kg - 3,4 lb) appliquée pendant au moins une minute.

## Technical Data

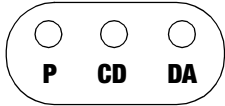
Operating Voltage	+10 to +16 V
Current consumption (no signal)	250 mA
Bit rate (Manchester Code)	10 Mbit/s
Dimensions W x H x D	92 mm x 32.5 mm x 100 mm (3.6 in. x 1.3 in. x 3.9 in.)
Weight	480 g (1.06 lb.)
Ambient temperature	0° C to 50° C
Storage temperature	-25° C to +85° C
Relative humidity	10% to 90% (non condensing)
<b>Coax cable interface (MDI): Transmitter</b>	
Output signal:	
AC	1,9 V +0,35 V, -0,5 V
DC	-1,025 V ±0,1 V
Rise/fall time	25 ns ±20%
Harmonic components:	
1st harmonic	-34 dB
2nd harmonic	-23 dB
3rd harmonic	-40 dB
4th harmonic	-39 dB
5th harmonic	-40 dB
6th harmonic	-47 dB
7th harmonic and higher	-55 dB
Preamble loss transmit	less than or equal to 2 bit
Stady State Delay	15 ns
Jabber time out	25 ms
Jabber reset	500 ms
<b>Coax cable interface (MDI): Receiver</b>	
Coax cable input current	5 µA
Capacitive load	2 pF
Input resistance	> 100 kΩ
Noise suppression	-250 mV
Preamble loss receive	1 bit (3 bit max.)
Steady State Delay	10 ns
Collision Detect threshold	-1,6 V
<b>Transceiver interface (AUI)</b>	
Input:	
Terminating resistance	78 Ω ±1%
Sensitivity	400 mV PP
Maximum DC component	±50 V
Output:	
Output voltage (Data and CD signal)	1,4 V PP
CD signal frequency	10 MHz ±20%
SQE test (heart beat)	switchable
delay time	1000 ns
length	800 ns
AUI cable length	50 m max.

Insulation voltage Transceiver interface/coax cable	2000 V dc
Insulation resistance: at 50/60 Hz at 3 MHz	500 kΩ 15 Ω
Pin assignment Transceiver interface	Transmit:DO + : Pin 3; DO - : Pin 10 Receive:DI + : Pin 5; DI - : Pin 12 Collision Detect:CI + : Pin 2; CI - : Pin 9 Power:GND: Pin 6; +12 V: Pin 13 Chassis/Shield:Pin 1, 4, 8, 11, 14
Connections: Transceiver interface Coax cable interface	15-pin Sub-D plug 1785-TR10B5: cable piercing tap
Displays 	* green LED: P (Power) – Supply voltage present * red LED: CD (Collision Detection) shortly on – Collision continuous on – Jabber Control active * yellow LED: DA (Data) – Sending or receiving data
Conductors/Wire Size/Category	Category 2 <sup>1</sup>
Agency Certification (when product is marked)	c  <ul style="list-style-type: none"> <li>Information Technology Equipment</li> <li>Industrial Control Equipment</li> <li>Class I, Div. 2, Groups A, B, C, D Hazardous Location</li> </ul>  <ul style="list-style-type: none"> <li>EN 50082-1, 2</li> <li>EN 55022, Radiated Emission Class B</li> <li>EN 60950</li> </ul> FCC Part 15, SubPart B

<sup>1</sup> Refer to the Industrial Automation Wiring and Grounding Guidelines for Noise Immunity, publication 1770-4.1.

[www.rockwellautomation.com](http://www.rockwellautomation.com)

### Power, Control and Information Solutions Headquarters

Americas: Rockwell Automation, 1201 South Second Street, Milwaukee, WI 53204-2496 USA, Tel: (1) 414.382.2000, Fax: (1) 414.382.4444

Europe/Middle East/Africa: Rockwell Automation, Vorstlaan/Boulevard du Souverain 36, 1170 Brussels, Belgium, Tel: (32) 2 663 0600, Fax: (32) 2 663 0640

Asia Pacific: Rockwell Automation, Level 14, Core F, Cyberport 3, 100 Cyberport Road, Hong Kong, Tel: (852) 2887 4788, Fax: (852) 2508 1846

Publication 1785-5.17 - January 1999

PN 955134-71

Copyright 1999 of Rockwell International Corporation. Printed in the U.S.A.