



## Stratix 5800 Ethernet Managed Switches

Catalog Numbers 1783-MMS10 Series A, 1783-MMS10A, 1783-MSS10AR Series B, 1783-MMS10E Series A, 1783-MMS10B Series A, 1783-MMS10BE Series A, 1783-MMS10 Series B, 1783-MMS10E Series B, 1783-MMS10B Series B, 1783-MMS10BE Series B, 1783-MMS10R Series B, 1783-MMS10ER Series B, 1783-MMS10EA Series B, 1783-MMS10EAR Series B, 1783-MMX8T Series A, 1783-MMX8E Series A, 1783-MMX8EA Series A, 1783-MMX8S Series A, 1783-MMX8SA Series A, 1783-MMX8TA Series A, 1783-MMX6T2S Series A, 1783-MMX16T Series A, 1783-MMX16E Series A, 1783-MMX14T2S Series A

Topic	Page
Parts List	5
Required Tools	5
Site Requirements	6
Connect an Expansion Module	6
Mount the Switch on a DIN Rail	7
Ground the Switch and Expansion Module	8

## Summary of Changes

This publication contains the following new or updated information. This list includes substantive updates only and is not intended to reflect all changes.

Topic	Page
UK and European Hazardous Location Approval	4
Stratix 5800 Switches, Series B	15



**ATTENTION:** Read this document and the documents listed in the Additional Resources section about installation, configuration and operation of this equipment before you install, configure, operate or maintain this product. Users are required to familiarize themselves with installation and wiring instructions in addition to requirements of all applicable codes, laws, and standards.

Activities including installation, adjustments, putting into service, use, assembly, disassembly, and maintenance are required to be carried out by suitably trained personnel in accordance with applicable code of practice. If this equipment is used in a manner not specified by the manufacturer, the protection provided by the equipment may be impaired.

**注意:** 在安装、配置、操作和维护本产品前，请阅读本文档以及“其他资源”部分列出的有关设备安装、配置和操作的相应文档。除了所有适用规范、法律和标准的相关要求之外，用户还必须熟悉安装和接线说明。

安装、调整、投运、使用、组装、拆卸和维护等各项操作必须由经过适当训练的专业人员按照适用的操作规范实施。

如果未按照制造商指定的方式使用该设备，则可能会损害设备提供的保护。

**ATENCIÓN:** Antes de instalar, configurar, poner en funcionamiento o realizar el mantenimiento de este producto, lea este documento y los documentos listados en la sección Recursos adicionales acerca de la instalación, configuración y operación de este equipo. Los usuarios deben familiarizarse con las instrucciones de instalación y cableado y con los requisitos de todos los códigos, leyes y estándares vigentes.

El personal debidamente capacitado debe realizar las actividades relacionadas a la instalación, ajustes, puesta en servicio, uso, ensamblaje, desensamblaje y mantenimiento de conformidad con el código de práctica aplicable. Si este equipo se usa de una manera no especificada por el fabricante, la protección provista por el equipo puede resultar afectada.

**ATENÇÃO:** Leia este e os demais documentos sobre instalação, configuração e operação do equipamento que estão na seção Recursos adicionais antes de instalar, configurar, operar ou manter este produto. Os usuários devem se familiarizar com as instruções de instalação e fiação além das especificações para todos os códigos, leis e normas aplicáveis.

É necessário que as atividades, incluindo instalação, ajustes, colocação em serviço, utilização, montagem, desmontagem e manutenção sejam realizadas por pessoal qualificado e especializado, de acordo com o código de prática aplicável.

Caso este equipamento seja utilizado de maneira não estabelecida pelo fabricante, a proteção fornecida pelo equipamento pode ficar prejudicada.

**ВНИМАНИЕ:** Перед тем как устанавливать, настраивать, эксплуатировать или обслуживать данное оборудование, прочитайте этот документ и документы, перечисленные в разделе «Дополнительные ресурсы». В этих документах изложены сведения об установке, настройке и эксплуатации данного оборудования. Пользователи обязаны ознакомиться с инструкциями по установке и прокладке соединений, а также с требованиями всех применимых норм, законов и стандартов.

Все действия, включая установку, наладку, ввод в эксплуатацию, использование, сборку, разборку и техническое обслуживание, должны выполняться обученным персоналом в соответствии с применимыми нормами и правилами.

Если оборудование используется не предусмотренным производителем образом, защита оборудования может быть нарушена.

**注意:** 本製品を設置、構成、稼働または保守する前に、本書および本機器の設置、設定、操作についての参考資料の該当箇所に記載されている文書に目を通してください。ユーザーは、すべての該当する条例、法律、規格の要件に加えて、設置および配線の手順に習熟している必要があります。

設置調整、運転の開始、使用、組立て、解体、保守を含む諸作業は、該当する実施規則に従って訓練を受けた適切な作業員が実行する必要があります。

本機器が製造メーカーにより指定されていない方法で使用されている場合、機器により提供されている保護が損なわれる恐れがあります。

**ACHTUNG:** Lesen Sie dieses Dokument und die im Abschnitt „Weitere Informationen“ aufgeführten Dokumente, die Informationen zu Installation, Konfiguration und Bedienung dieses Produkts enthalten, bevor Sie dieses Produkt installieren, konfigurieren, bedienen oder warten. Anwender müssen sich neben den Bestimmungen aller anwendbaren Vorschriften, Gesetze und Normen zusätzlich mit den Installations- und Verdrahtungsanweisungen vertraut machen.

Arbeiten im Rahmen der Installation, Anpassung, Inbetriebnahme, Verwendung, Montage, Demontage oder Instandhaltung dürfen nur durch ausreichend geschulte Mitarbeiter und in Übereinstimmung mit den anwendbaren Ausführungsvorschriften vorgenommen werden.

Wenn das Gerät in einer Weise verwendet wird, die vom Hersteller nicht vorgesehen ist, kann die Schutzfunktion beeinträchtigt sein.

**ATTENTION:** Lisez ce document et les documents listés dans la section Ressources complémentaires relatifs à l'installation, la configuration et le fonctionnement de cet équipement avant d'installer, configurer, utiliser ou entretenir ce produit. Les utilisateurs doivent se familiariser avec les instructions d'installation et de câblage en plus des exigences relatives aux codes, lois et normes en vigueur. Les activités relatives à l'installation, le réglage, la mise en service, l'utilisation, l'assemblage, le démontage et l'entretien doivent être réalisées par des personnes formées selon le code de pratique en vigueur.

Si cet équipement est utilisé d'une façon qui n'a pas été définie par le fabricant, la protection fournie par l'équipement peut être compromise.

**주의:** 본 제품 설치, 설정, 작동 또는 유지 보수하기 전에 본 문서를 포함하여 설치, 설정 및 작동에 관한 참고 자료 섹션의 문서들을 반드시 읽고 숙지하십시오. 사용자는 모든 관련 규정, 법규 및 표준에서 요구하는 사항에 대해 반드시 설치 및 배선 지침을 숙지해야 합니다.

설치, 조정, 가동, 사용, 조립, 분해, 유지보수 등 모든 작업은 관련 규정에 따라 적절한 교육을 받은 사용자를 통해서만 수행해야 합니다.

본 장비를 제조사가 명시하지 않은 방법으로 사용하면 장비의 보호 기능이 손상될 수 있습니다.

**ATTENZIONE:** Prima di installare, configurare ed utilizzare il prodotto, o effettuare interventi di manutenzione su di esso, leggere il presente documento ed i documenti elencati nella sezione "Altre risorse", riguardanti l'installazione, la configurazione ed il funzionamento dell'apparecchiatura. Gli utenti devono leggere e comprendere le istruzioni di installazione e cablaggio, oltre ai requisiti previsti dalle leggi, codici e standard applicabili.

Le attività come installazione, regolazioni, utilizzo, assemblaggio, disassemblaggio e manutenzione devono essere svolte da personale adeguatamente addestrato, nel rispetto delle procedure previste.

Qualora l'apparecchio venga utilizzato con modalità diverse da quanto previsto dal produttore, la sua funzione di protezione potrebbe venire compromessa.

**DIKKAT:** Bu ürünün kurulumu, yapılandırılması, işletilmesi veya bakımı öncesinde bu dokümanı ve bu ekipmanın kurulumu, yapılandırılması ve işletimi ile ilgili İlave Kaynaklar bölümünde yer listelenmiş dokümanları okuyun. Kullanıcılar yürürlükteki tüm yönetmelikler, yasalar ve standartların gereksinimlerine ek olarak kurulum ve kablolama talimatlarını da öğrenmek zorundadır.

Kurulum, ayarlama, hizmete alma, kullanma, parçaları birleştirme, parçaları sökme ve bakım gibi aktiviteler sadece uygun eğitimli almış kişiler tarafından yürürlükteki uygulama yönetmeliklerine uygun şekilde yapılabilir.

Bu ekipman üretici tarafından belirlenmiş amacın dışında kullanılırsa, ekipman tarafından sağlanan koruma bozulabilir.

**注意事項:** 在安装、設定、操作或維護本產品前，請先閱讀此文件以及列於「其他資源」章節中所有有關安裝、設定與操作此設備的文件。使用者必須熟悉安裝和配線指示，並符合所有法規、法律和標準要求。

包括安裝、調整、交付使用、使用、組裝、拆卸和維護等動作都必須交由已經過適當訓練的人員進行，以符合適用的實作法規。

如果將設備用於非製造商指定的用途時，可能會造成設備所提供的保護功能受損。

**POZOR:** Než začnete instalovat, konfigurovat či provozovat tento výrobek nebo provádět jeho údržbu, přečtěte si tento dokument a dokumenty uvedené v části Dodatečné zdroje ohledně instalace, konfigurace a provozu tohoto zařízení. Uživatelé se musejí vedle požadavků všech relevantních vyhlášek, zákonů a norem nutně seznámit také s pokyny pro instalaci a elektrické zapojení.

Činnosti zahrnující instalaci, nastavení, uvedení do provozu, užívání, montáž, demontáž a údržbu musí vykonávat vhodně proškolený personál v souladu s příslušnými prováděcími předpisy.

Pokud se toto zařízení používá způsobem neodpovídajícím specifikaci výrobce, může být narušena ochrana, kterou toto zařízení poskytuje.

**UWAGA:** Przed instalacją, konfiguracją, użytkowaniem lub konserwacją tego produktu należy przeczytać niniejszy dokument oraz wszystkie dokumenty wymienione w sekcji Dodatkowe źródła omawiające instalację, konfigurację i procedury użytkowania tego urządzenia. Użytkownicy mają obowiązek zapoznać się z instrukcjami dotyczącymi instalacji oraz oprzewodowania, jak również z obowiązującymi kodeksami, prawem i normami.

Działania obejmujące instalację, regulację, przekazanie do użytkowania, użytkowanie, montaż, demontaż oraz konserwację muszą być wykonywane przez odpowiednio przeszkolony personel zgodnie z obowiązującym kodeksem postępowania.

Jesli urządzenie jest użytkowane w sposób inny niż określony przez producenta, zabezpieczenie zapewniane przez urządzenie może zostać ograniczone.

**OBBS!** Läs detta dokument samt dokumentet, som står listat i avsnittet Övriga resurser, om installation, konfigurering och drift av denna utrustning innan du installerar, konfigurerar eller börjar använda eller utföra underhållsarbete på produkten. Användare måste bekanta sig med instruktioner för installation och kabeldragning, förutom krav enligt gällande koder, lagar och standarder.

Åtgärder som installation, justering, service, användning, montering, demontering och underhållsarbete måste utföras av personal med lämplig utbildning enligt lämpligt bruk.

Om denna utrustning används på ett sätt som inte anges av tillverkaren kan det hända att utrustningens skyddsanordningar försätts ur funktion.

**LET OP:** Lees dit document en de documenten die genoemd worden in de paragraaf Aanvullende informatie over de installatie, configuratie en bediening van deze apparatuur voordat u dit product installeert, configureert, bedient of onderhoudt. Gebruikers moeten zich vertrouwd maken met de installatie en de bedradingsinstructies, naast de vereisten van alle toepasselijke regels, wetten en normen.

Activiteiten zoals het installeren, afstellen, in gebruik stellen, gebruiken, monteren, demonteren en het uitvoeren van onderhoud mogen uitsluitend worden uitgevoerd door hiervoor opgeleid personeel en in overeenstemming met de geldende praktijkregels.

Indien de apparatuur wordt gebruikt op een wijze die niet is gespecificeerd door de fabrikant, dan bestaat het gevaar dat de beveiliging van de apparatuur niet goed werkt.

---

**Environment and Enclosure**

---



**ATTENTION:** This equipment is intended for use in a Pollution Degree 2 industrial environment, in overvoltage Category II applications (as defined in EN/IEC 60664-1), at altitudes up to 2000 m (6562 ft) without derating.

This equipment is not intended for use in residential environments and may not provide adequate protection to radio communication services in such environments.

This equipment is supplied as open-type equipment for indoor use. It must be mounted within an enclosure that is suitably designed for those specific environmental conditions that will be present and appropriately designed to prevent personal injury resulting from accessibility to live parts. The enclosure must have suitable flame-retardant properties to prevent or minimize the spread of flame, complying with a flame spread rating of 5VA or be approved for the application if nonmetallic. The interior of the enclosure must be accessible only by the use of a tool. Subsequent sections of this publication may contain more information regarding specific enclosure type ratings that are required to comply with certain product safety certifications.

In addition to this publication, see the following:

- Industrial Automation Wiring and Grounding Guidelines, publication [1770-4.1](#), for more installation requirements.
  - NEMA Standard 250 and EN/IEC 60529, as applicable, for explanations of the degrees of protection provided by enclosures."
- 

**Class A Notice for Taiwan and other Traditional Chinese Markets**

---



**ATTENTION:** This is a Class A Information Product. When used in a residential environment, it may cause radio frequency interference. Under such circumstances, the user may be requested to take appropriate countermeasures.

警告 這是甲類資訊產品，在居住環境中使用時，可能會造成射頻干擾，在這種情況下，使用者會被要求採取某些適當的對策。

---

**Prevent Electrostatic Discharge**

---



**ATTENTION:** This equipment is sensitive to electrostatic discharge, which can cause internal damage and affect normal operation. Follow these guidelines when you handle this equipment:

- Touch a grounded object to discharge potential static.
- Wear an approved grounding wriststrap.
- Do not touch connectors or pins on component boards.
- Do not touch circuit components inside the equipment.
- Use a static-safe workstation, if available.
- Store the equipment in appropriate static-safe packaging when not in use.

---



**ATTENTION:** This product is grounded through the DIN rail to chassis ground. Use zinc-plated chromate-passivated steel DIN rail to assure proper grounding. The use of other DIN rail materials (for example, aluminum or plastic) that can corrode, oxidize, or are poor conductors, can result in improper or intermittent grounding. Secure DIN rail to mounting surface approximately every 200 mm (7.8 in.) and use end-anchors appropriately. Be sure to ground the DIN rail properly. Refer to Industrial Automation Wiring and Grounding Guidelines, Rockwell Automation publication [1770-4.1](#), for more information.

---



**ATTENTION:** Under certain conditions, viewing the optical port may expose the eye to hazard. When viewed under some conditions, the optical port may expose the eye beyond the maximum permissible exposure recommendations.

---



**ATTENTION:** Class 1 laser product. Laser radiation is present when the system is open and interlocks bypassed. Only trained and qualified personnel should be allowed to install, replace, or service this equipment.

---



**ATTENTION:** (Catalog numbers 1783-MMS10E Series A, 1783-MMS10BE Series A). This equipment is certified for use only within the surrounding air temperature range of 0...55 °C (32...131 °F). The equipment must not be used outside of this range.

---



**ATTENTION:** (Catalog numbers 1783-MMS10 Series A, 1783-MMS10B Series A, 1783-MMS10 Series B, 1783-MMS10E Series B, 1783-MMS10B Series B, 1783-MMS10BE Series B, 1783-MMS10R Series B, 1783-MMS10ER Series B, 1783-MMS10EA Series B, 1783-MMS10EAR Series B, 1783-MMS10A Series B and 1783-MMS10AR Series B). This equipment is certified for use only within the surrounding air temperature range of 0...60 °C (32...140 °F). The equipment must not be used outside of this range.

---



**ATTENTION:** Use only a soft dry anti-static cloth to wipe down equipment. Do not use any cleaning agents.

---

**UK and European Hazardous Location Approval**

**The following applies to products marked : Such modules:**

- Are Equipment Group II, Equipment Category 3, and comply with the Essential Health and Safety Requirements relating to the design and construction of such equipment given in Annex II to Directive 2014/34/EU and Schedule 1 of the UKEX Regulation 2016 No.1107. See the UKEx and EU Declaration of Conformity at <http://www.rockwellautomation.com/global/certification/overview> for details.
- (Catalog numbers 1783-MMS10 Series A, 1783-MMS10E Series A, 1783-MMS10B Series A, 1783-MMS10BE Series A). The type of protection for base and standard switches is Ex nA nC IIC T4 Gc according to EN 60079-15:2010.
- (Catalog numbers 1783-MMS10 Series B, 1783-MMS10A Series B, 1783-MMS10AR Series B, 1783-MMS10E Series B, 1783-MMS10B Series B, 1783-MMS10BE Series B, 1783-MMS10R Series B, 1783-MMS10ER Series B, 1783-MMS10EA Series B, 1783-MMS10EAR Series B). The type of protection for base and standard switches is Ex ec IIC T4 Gc according to EN IEC 60079-7: 2015 +A1:2018.
- (Catalog numbers 1783-MMX8T Series A, 1783-MMX8E Series A, 1783-MMX8EA Series A, 1783-MMX8S Series A, 1783-MMX8SA Series A, 1783-MMX8TA Series A, 1783-MMX8T2S Series A, 1783-MMX16T Series A, 1783-MMX16E Series A, 1783-MMX14T2S Series A). The type of protection for expansion modules is Ex ec IIC T4 Gc according to EN IEC 60079-7: 2015 +A1:2018.
- Reference certificate number DEMKO 19 ATEX 2207X.
- Reference certificate number UL24UKEX2981X.
- Are intended for use in areas in which explosive atmospheres caused by gases, vapors, mists, or air are unlikely to occur, or are likely to occur only infrequently and for short periods. Such locations correspond to Zone 2 classification according to UKEX Regulation 2016 No. 1107 and ATEX directive 2014/34/EU.



**Special Conditions of Use**



**WARNING:**

- This equipment is not resistant to sunlight or other sources of UV radiation.
- This equipment shall be mounted in an UKEX/ATEX Zone 2 certified enclosure with a minimum ingress protection rating of at least IP54 (in accordance with EN IEC 60079-0) and used in an environment of not more than Pollution Degree 2 (as defined in EN IEC 60664-1) when applied in Zone 2 environments. The enclosure must be accessible only by the use of a tool.
- This equipment shall be used within its specified ratings defined by Rockwell Automation.
- Transient protection shall be provided that is set at a level not exceeding 140% of the peak rated voltage at the supply terminals to the equipment.
- The instructions in the user manual shall be observed.
- Secure any external connections that mate to this equipment by using screws, sliding latches, threaded connectors, or other means provided with this product.
- Do not disconnect equipment unless power has been removed or the area is known to be nonhazardous.

**North American Hazardous Location Approval**

<b>The following information applies when operating this equipment in hazardous locations.</b>	<b>Informations sur l'utilisation de cet équipement en environnements dangereux.</b>
<p>Products marked "CL I, DIV 2, GP A, B, C, D" are suitable for use in Class I Division 2 Groups A, B, C, D, Hazardous Locations and nonhazardous locations only. Each product is supplied with markings on the rating nameplate indicating the hazardous location temperature code. When combining products within a system, the most adverse temperature code (lowest "T" number) may be used to help determine the overall temperature code of the system. Combinations of equipment in your system are subject to investigation by the local Authority Having Jurisdiction at the time of installation.</p>	<p>Les produits marqués "CL I, DIV 2, GP A, B, C, D" ne conviennent qu'à une utilisation en environnements de Classe I Division 2 Groupes A, B, C, D dangereux et non dangereux. Chaque produit est livré avec des marquages sur sa plaque d'identification qui indiquent le code de température pour les environnements dangereux. Lorsque plusieurs produits sont combinés dans un système, le code de température le plus défavorable (code de température le plus faible) peut être utilisé pour déterminer le code de température global du système. Les combinaisons d'équipements dans le système sont sujettes à inspection par les autorités locales qualifiées au moment de l'installation.</p>
<div style="display: flex; align-items: center;">  <div> <p><b>WARNING:</b> <b>Explosion Hazard -</b></p> <ul style="list-style-type: none"> <li>• Do not disconnect equipment unless power has been removed or the area is known to be nonhazardous.</li> <li>• Do not disconnect connections to this equipment unless power has been removed or the area is known to be nonhazardous. Secure any external connections that mate to this equipment by using screws, sliding latches, threaded connectors, or other means provided with this product.</li> <li>• Substitution of components may impair suitability for Class I, Division 2.</li> <li>• If this product contains batteries, they must only be changed in an area known to be nonhazardous.</li> </ul> </div> </div>	<div style="display: flex; align-items: center;">  <div> <p><b>AVERTISSEMENT:</b> <b>Risque d'Explosion -</b></p> <ul style="list-style-type: none"> <li>• Couper le courant ou s'assurer que l'environnement est classé non dangereux avant de débrancher l'équipement.</li> <li>• Couper le courant ou s'assurer que l'environnement est classé non dangereux avant de débrancher les connecteurs. Fixer tous les connecteurs externes reliés à cet équipement à l'aide de vis, loquets coulissants, connecteurs filetés ou autres moyens fournis avec ce produit.</li> <li>• La substitution de composants peut rendre cet équipement inadapté à une utilisation en environnement de Classe I, Division 2.</li> <li>• S'assurer que l'environnement est classé non dangereux avant de changer les piles.</li> </ul> </div> </div>

**North American Zones:**  
**UL 60079-0**  
**UL 60079-7**  
**CAN/CSA-C22.2 NO. 60079-0**  
**CAN/CSA C22.2 NO. 60079-7**



**WARNING:** If you connect or disconnect the communications cable with power applied to this module or any device on the network, an electric arc can occur. This could cause an explosion in hazardous location installations. Be sure that power is removed or the area is nonhazardous before proceeding.



**WARNING:** If you connect or disconnect wiring while the field-side power is on, an electric arc can occur. This could cause an explosion in hazardous location installations. Be sure that power is removed or the area is nonhazardous before proceeding.



**WARNING:** When you insert or remove the small form-factor pluggable (SFP) optical transceiver while power is on, an electric arc can occur. This could cause an explosion in hazardous location installations. Be sure that power is removed or the area is nonhazardous before proceeding.

## Parts List

Verify that you have these items.

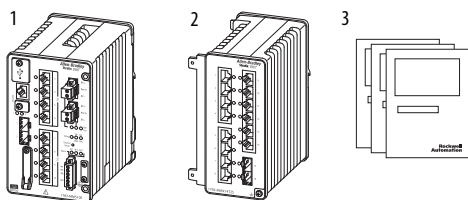

- 1 Stratix® 5800 switch, including two power connectors and one alarm relay connector
- 2 (Optional) Stratix 5800 expansion module
- 3 Documentation



At the end of its life, this equipment should be collected separately from any unsorted municipal waste.

## Required Tools

Obtain these tools:

- Ratcheting torque screwdriver that exerts up to 2.03 N•m (18 in•lb) of pressure
- For the protective ground connector, obtain one or two #6 ring terminals
- Crimping tool
- 10-gauge copper ground wire
- For DC power connections, use UL- and CSA-rated style 1007 or 1569 twisted-pair copper appliance wiring material (AWM) wire
- Wire-stripping tools for stripping 10- and 14-gauge wires
- A number-2 Phillips screwdriver
- A screwdriver

For better EMC performance, we recommend that you use S/UTP or SF/UTP cables for copper Ethernet ports. For details on S/UTP and SF/UTP, refer to the ISO/IEC11801 standard.

For simplified cabling, the automatic medium-dependent interface crossover (auto-MDIX) feature is enabled by default on the switch. With auto-MDIX enabled, the switch detects the required cable type for copper Ethernet connections and configures the interfaces accordingly. You can use a crossover or a straight-through cable for connections to a 10/100/1000 port, regardless of the device on the other end of the connection.

## Site Requirements

Observe these site requirements:

- The device must be installed in vertical position.
- For 10/100/1000 ports, the cable length from a switch to an attached device cannot exceed 100 m (328 ft).
- For 100Base-FX fiber-optic ports, the cable length from a switch to an attached device cannot exceed 2 km (6562 ft).
- Clearance to front and rear panels must meet these conditions:
  - Front-panel status indicators are easily read.
  - Access to ports is sufficient for unrestricted cabling.
  - Front-panel direct current (DC) power and relay connectors are within reach of the connection to the DC power source.
- Airflow around the switch is unrestricted. To help prevent the switch from overheating, observe these minimum clearances:
  - Top and bottom: 50.8 mm (2.0 in.)
  - Left and right: 50.8 mm (2.0 in.)
  - Front: 50.8 mm (2.0 in.)
- For installation in hazardous locations, make sure that the temperature surrounding the unit does not exceed the maximum operating temperature of the device. See the specifications on [page 15](#).
- Cabling must be away from sources of electrical noise, such as radios, power lines, and fluorescent lighting fixtures.

## Connect an Expansion Module

If you have an expandable switch model, you can connect one expansion module. For switch and expansion module compatibility restrictions, see the Stratix Ethernet Device Specifications Technical Data, publication [1783-TD001](#).



**WARNING:** Do not attempt to connect or separate an expansion module from a base switch in a hazardous environment. Doing so can produce a spark and create an explosion hazard.

**IMPORTANT** Be sure that power is removed from the switch before you add an expansion module.

1. Remove the two screws securing the side cover plate to the switch.
2. Remove the two screws from the front of the expansion chassis and the two screws from the rear of the base.

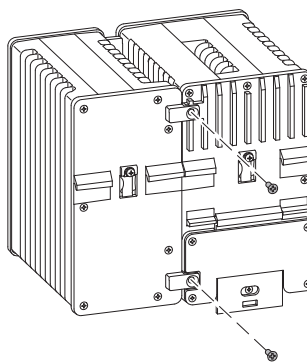
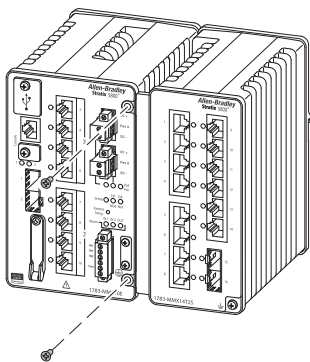

3. Align the tabs on the top and bottom-left front of the expansion module with the slots on the top and bottom-right side of the switch.
4. Align the tabs on the top and bottom-left rear of module and the holes at the top and bottom-right rear of switch.
5. Press the expansion module and the switch together, so that the electrical connections engage and the screw holes align.

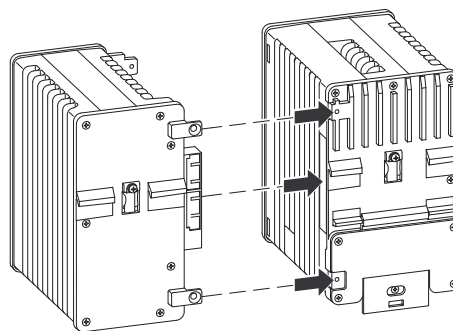
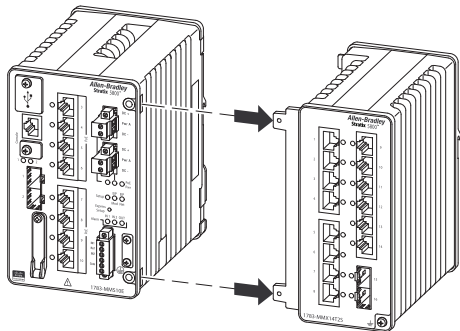

6. Secure the four flathead Phillips screws with 0.565 N•m (5...6 in•lbs) torque.

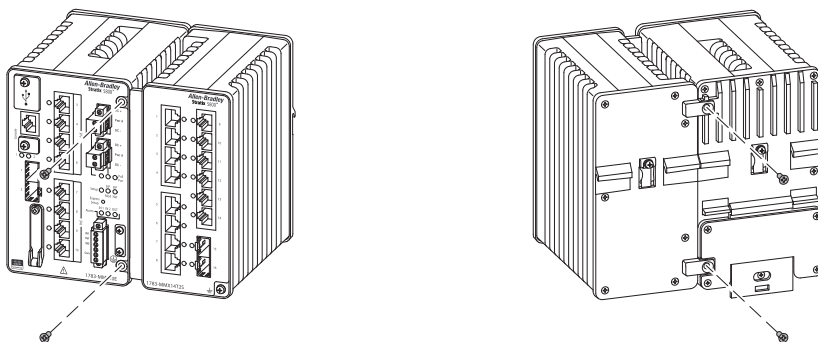

## Mount the Switch on a DIN Rail

The switch ships with a spring-loaded latch on the rear panel for a mounting on a DIN rail.

---

**IMPORTANT** The device is designed to mount on a DIN rail that conforms to Standard EN50022.

---

To help prevent excessive side-to-side movement of the unit, we recommend that you install DIN rail stop plates, such as mouser part numbers 653-PFP-M, 651-1201662 or 845-CA402. You can install these end stops on one or both sides of the device to limit excessive side to side movement that typically occurs in high vibration environments.

You can mount the switch as a standalone device on the DIN rail or with the expansion modules already connected. You must connect an expansion module to the switch before you mount the switch on the DIN rail.

---

**IMPORTANT** The switch must be mounted in an upright orientation, as shown in these instructions. Alternative mounting orientations are not supported.

---

1. Position the rear panel of the switch directly in front of the DIN rail.  
Be sure that the DIN rail fits in the space between the two hooks near the top of the switch and the spring-loaded latch near the bottom.
2. Hold the bottom of the switch away from the DIN rail and place the two hooks on the back of the switch over the top of the DIN rail.

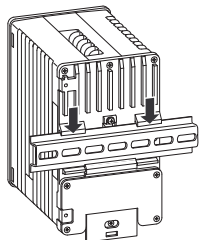

3. To cause the latch at the bottom rear of the switch to move down and snap into place, push the switch toward the DIN rail.

## Ground the Switch and Expansion Module

**IMPORTANT** Do not rely on the switch ground for an expansion module. When an expansion module is connected, it must be grounded using the screw on the expansion module. This is an EMC ground and not a safety ground, unlike the one on the main chassis.

To make sure that the equipment is reliably connected to earth ground, follow the grounding procedure instructions, and use a UL Listed ring terminal lug suitable for number 10 AWG wire.

Use at least a 10 AWG or 2.6 mm<sup>2</sup> conductor to connect to the external grounding screw.

The ground lug is not supplied with the switch. You can use one of these options:

- Single ring terminal
  - Two single ring terminals
  - Ring terminal on expansion module
1. To remove the ground screw from the front panel of the switch or expansion module, use a standard Phillips screwdriver or a ratcheting torque screwdriver with a Phillips head.  
Store the ground screw for later use.
  2. Use the manufacturers guidelines to determine the wire length to be stripped.
  3. Insert the ground wire into the ring terminal lug and use a crimping tool to crimp the terminal to the wire.  
If two ring terminals are being used, repeat this action for a second ring terminal.

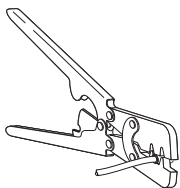

4. Slide the ground screw through the ring terminal.
5. Insert the ground screw into the functional ground screw opening on the front panel.

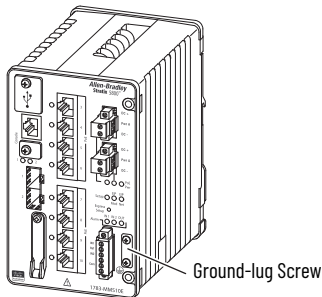

6. Use a ratcheting torque screwdriver to tighten the ground screws and ring terminal lugs to the front panel to 0.51 N•m (4.5 lb•in). The torque must not exceed 0.51 N•m (4.5 lb•in).
7. Attach the other end of the ground wire to a grounded bare-metal surface, such as a ground bus or a grounded DIN rail.

## Wire the DC Power Source

The switch meets the voltage dips and interruptions requirements of IEC 61850-3 only when powered by a redundant power supply configuration.

1. Locate the two power connectors on the switch front panel labeled Pwr A and Pwr B.

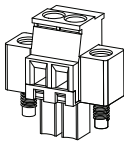

2. Identify the positive and return DC power connections by using the labels on the switch panel.

DC +	Positive DC power connection
DC -	Return DC power connection

3. Measure two strands of twisted-pair copper wire 14 AWG (1.6 mm<sup>2</sup>) long enough to connect to the DC power source.
4. Use a wire-stripping tool to strip each of the two wires to 6.3 mm (0.25 in.) ± 0.5 mm (0.02 in.).

Do not strip more than 6.8 mm (0.27 in.) of insulation from the wire. Stripping more than the recommended amount of wire can leave exposed wire from the connector after installation.

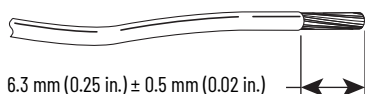

5. Remove the two captive screws that attach the power connector to the switch, and remove the power connector. Remove both connectors if you are connecting to two power sources.

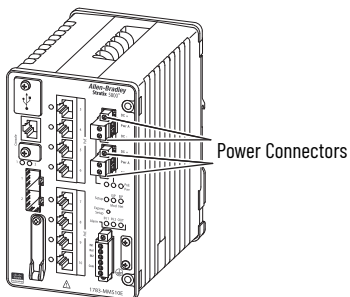

6. On the power connector, insert the exposed part of the positive wire into the connection labeled "+" and the exposed part of the return wire into the connection labeled "-".

Make sure that you cannot see any wire lead. Only wire with insulation can extend from the connector.

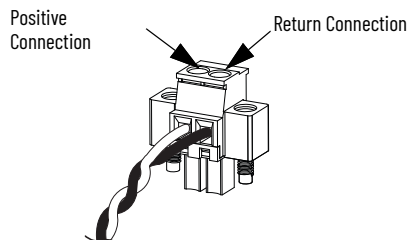

7. Use a ratcheting torque screwdriver to torque the power connector captive screws above the installed wire leads to 0.565 N•m (5 in•lb), the maximum recommended torque.

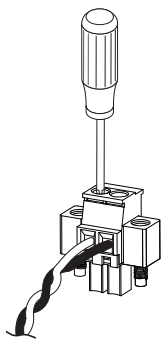

8. Connect the other end of the positive wire to the positive terminal on the DC power source.

- Connect the other end of the return wire to the return terminal on the DC power source.

**IMPORTANT** On switches that support PoE, do not connect the negative (return) terminal of the DC power source to earth ground.

To test the switch, one power connection is sufficient. To install the switch with a second power source, repeat the preceding steps for the second power connector.

## Install the Power Connectors on the Switch

- Insert one power connector into the Pwr A receptacle on the switch front panel, and the other into the Pwr B receptacle.
- Use a screwdriver to tighten the captive screws on the sides of each power connector.
- Use a ratcheting torque screwdriver to torque the power connector captive screws to 0.226 N•m (2 in•lb), the maximum recommended torque.
- To apply power to a switch that is directly connected to a DC power source, locate the circuit breaker on the panel board that services the DC circuit. Then switch the circuit breaker to the On position.

## Wire External Alarms

Alarm signals are connected to the switch through the six-pin alarm connector. Three connections are dedicated to the two alarm input circuits: alarm input 1, alarm input 2, and a reference ground. An alarm input and the reference ground wiring connection are required to complete one alarm input circuit. The three connections that remain are for the alarm output circuit: a normally open output, a normally closed output, and a common signal. An alarm output and the common wiring connection are required to complete one alarm output circuit. The labels for the alarm connector are on the switch panel and shown in the following table.

Label	Connection
IN1	Alarm Input 1
REF	Alarm Input Reference Ground connection
IN2	Alarm Input 2
N.C.	Alarm Output Normally Closed (N.C.) connection
COM	Alarm Output Common connection
N.O.	Alarm Output Normally Open (N.O.) connection

- Remove the captive screws that hold the alarm connector on the switch, and remove the connector from the switch chassis.

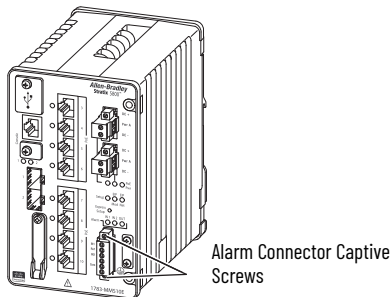

- Measure two strands of twisted-pair wire (16...18 AWG) long enough to connect to the external alarm device. Choose between creating an external alarm input or output circuit.
- Use a wire stripper to remove the casing from both ends of each wire to 6.3 mm (0.25 in.) ± 0.5 mm (0.02 in.). Do not strip more than 6.8 mm (0.27 in.) of insulation from the wires. Stripping more than the recommended amount of wire can leave exposed wire from the alarm connector after installation.
- Insert the exposed wires for the external alarm device into the connections for an alarm input or output circuit setup. For example, to wire an alarm input circuit, complete the IN1 and REF connections

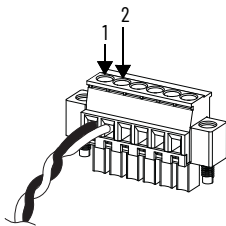

1	External device connection 1 (IN1)
2	External device connection 2 (REF)

- Use a ratcheting torque screwdriver to tighten the alarm connector captive screw (above the installed wire leads) to 0.23 N•m (2.0 in•lb).

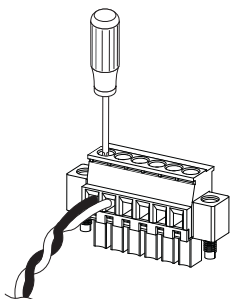

- Repeat steps 2...5 to insert the input and output wires of one more external alarm device into the alarm connector. The following figure shows the completed wiring for two external alarm devices. The first alarm device circuit is wired as an alarm input circuit. The IN1 and REF connections complete the circuit. The second alarm device circuit is wired as an alarm output circuit that works on a normally open contact basis. The N.O. and COM connections complete the circuit.

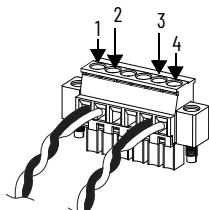

1	External device connection 1 (IN1)
2	External device connection 2 (REF)
3	COM wired connection
4	N.O. wired connection

### Install the Alarm Relay Connector on the Switch

- Insert the alarm relay connector into the receptacle on the switch front panel.
- Use a ratcheting torque screwdriver to tighten the captive screws on the sides of the alarm relay connector.

### Install or Remove an SFP Module



**ATTENTION:** Use SFP modules from only Rockwell Automation. For details about supported modules, see the Stratix Ethernet Device Specifications Technical Data, publication [1783-TD001](#).

On switch catalog numbers support communication over fiber-optic cable. SFP modules are inserted into SFP module slots on the front of the switch. These field-replaceable modules provide the uplink optical interfaces, send (TX) and receive (RX).

You can use any combination of compatible SFP modules:

- Each SFP module must be of the same type as the SFP module on the other end of the cable. The cable must not exceed the stipulated cable length for proper communications.
- The overall temperature rating of the combined modules (switch and installed SFP modules) is limited to the lowest maximum temperature rating and the highest minimum temperature rating.
- For cable length and temperature specifications, see the Stratix Ethernet Device Specifications Technical Data, publication [1783-TD001](#).

**IMPORTANT** Attach an ESD-preventive wriststrap to your wrist and to a grounded bare metal surface.

To install an SFP module, use the following steps.

- Grasp both sides of the SFP module and align the module sideways in front of the slot opening.



**ATTENTION:** If the SFP module cannot be fully inserted, stop! Do not force the module into the slot. Rotate the SFP module 180° and try again.

- Insert the SFP module into the slot as shown in the following figure until you feel the connector on the module snap into place in the rear of the slot.

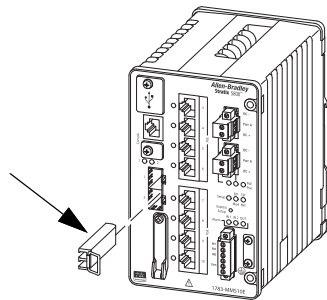

3. Remove the dust plugs from the SFP module optical ports and store them for later use.

To remove an SFP module from an SFP slot, use the following steps.

1. Disconnect the fiber LC connector from the SFP module.
2. To keep the optical interfaces clean, insert a dust plug into the optical ports of the SFP module.
3. Unlock and remove the SFP module.
4. If the module has a bale-clasp latch, swing the bale toward you and pull it gently to eject the module. If the bale-clasp latch is obstructed and you cannot use your index finger to open it, use a small, screwdriver, or other long, narrow instrument to open the latch.

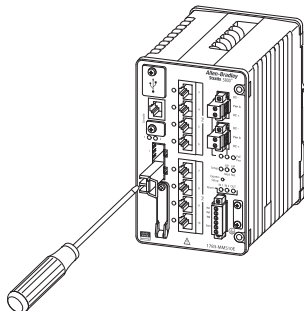

5. Grasp the SFP module between your thumb and index finger, and carefully remove it from the module slot.
6. Place the removed SFP module in an anti-static bag or other protective environment.

## Install or Remove the SD Card

Optionally, you can copy the firmware image or switch configuration to an SD card. We strongly recommend that you use an SD card as the primary storage for future replacement if there is a hardware failure.

To install or replace the SD card, follow these steps.

1. On the front of the switch, locate the door that helps protect the SD card slot.
2. Loosen the captive screw at the top of the door by using a Phillips screwdriver to open the door.
3. To install a card, slide it into the slot, and press it in until it clicks in place.  
The card is keyed so that you cannot fully insert it the wrong way.

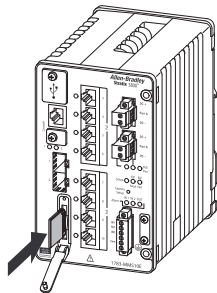

4. To remove the card, push it in until it releases for it to pop out.  
Place it in an anti-static bag to help protect it from static discharge.

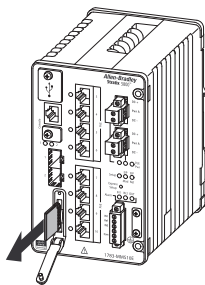

5. After the card is installed, close the guard door and fasten the captive screw by using a Phillips screwdriver to keep the door in place.

## Connect to 10/100/1000 Ports

The 10/100/1000 ports automatically configure themselves to operate at the speed of attached devices. If the attached ports do not support autonegotiation, you can explicitly set the speed and duplex parameters. Connected devices that do not autonegotiate or that have speed and duplex parameters that are manually set can reduce performance or result in no connection.

To maximize performance, choose one of these methods for configuring the Ethernet ports:

- Let the ports autonegotiate both speed and duplex.
- Set the port speed and duplex parameters on both ends of the connection.

To connect to 10Base-T, 100BASE-TX, or 1000BASE-T devices, follow these steps.

1. When connecting to workstations, servers, or routers, connect a straight-through cable to an RJ45 connector on the front panel. When connecting to 1000BASE-T-compatible devices, use a twisted four-pair, Category 5, or higher cable.
2. Connect the other end of the cable to an RJ45 connector on the other device.

The port status indicator turns on when both the switch and the connected device have established a connection. The port status indicator is amber while Spanning Tree Protocol (STP) discovers the topology and searches for loops. This process can take up to 30 seconds, and then the port status indicator turns green.

## Connect to SFP Modules

If you installed an SFP module, follow these steps to connect a fiber-optic cable to an SFP module.

1. Remove the rubber plugs from the module port and fiber-optic cable, and store them for future use.
2. Insert one end of the fiber-optic cable into the SFP module port.
3. Insert the other cable end into a fiber-optic receptacle on a target device.

## Confirm Installation

To confirm the installation, power on the switch, and verify that the switch powers up.

1. Apply power to the switch.  
If the switch is directly connected to a DC power source, switch the circuit breaker to the ON position.
2. Verify the startup process.  
The Setup status indicator blinks green as the IOS software image loads. If the routine fails, the Setup status indicator turns red.

---

**IMPORTANT** Startup failures are fatal to the switch. If your switch does not complete the start sequence, contact Rockwell Automation.

---

## Remove the Switch from the DIN Rail

To remove the switch from a DIN rail, follow these steps.

1. Remove power from the switch and disconnect all cables and connectors from the front panel of the switch.
2. Insert a tool, such as a screwdriver, in the slot at the bottom of the spring-loaded latch and use it to release the latch from the rail.

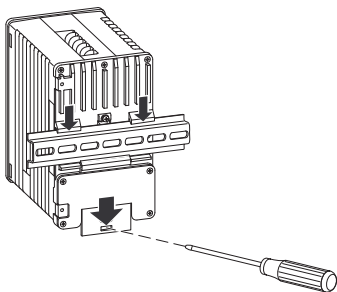

3. Pull the bottom of the switch away from the DIN rail and lift the hooks off the top of the DIN rail.
4. Remove the switch from the DIN rail.

## Specifications

### Stratix 5800 Switches, Series A

Attribute	1783-MMS10BE Series A	1783-MMS10E Series A	1783-MMS10 Series A	1783-MMS10B Series A
Temperature, operating <sup>(1)</sup> IEC 60068-2-1 (Test Ad, Operating Cold) IEC 60068-2-2 (Test Bd, Operating Dry Heat) IEC 60068-2-14 (Test Nb, Operating Thermal Shock)	-40 °C ≤ Ta ≤ +55 °C (-40 °F ≤ Ta ≤ +131 °F)		-40 °C ≤ Ta ≤ +60 °C (-40 °F ≤ Ta ≤ +140 °F)	
Temperature, surrounding air, max	60 °C (140 °F)			
Enclosure type rating	None (open-style)			
Power input, max	12...54V DC, 5.5 A	12...54V DC, 10.6 A	12...48V DC, 4.0 A	12...48V DC, 2.2 A
Alarm relay	30V DC, 1 A, or 48V DC, 0.5 A			
Wire size, Ethernet connections	RJ45 connector according to IEC 60603-7, 2 or 4 pair Category 5e minimum cable according to TIA 568-B.1 or Category 5 cable according to ISO/IEC 24702			
Wire size, power connections, max	0.5...0.8 mm <sup>2</sup> (20...18 AWG) solid or stranded, UL/CSA-rated style 1007, or 1569 twisted-pair copper appliance wiring material (AWM) wire (such as Belden part number 9318), 6.3 mm (0.25 in.) ± 0.5 mm (0.02 in.) strip length			
Wire size, ground connection, max	4.0 mm <sup>2</sup> (12 AWG) minimum, stranded copper wire			
Wire size, alarm connections, max	0.5...0.8 mm <sup>2</sup> (20...18 AWG) solid or stranded, UL/CSA-rated style 1007, or 1569 twisted-pair copper appliance wiring material (AWM) wire (such as Belden part number 9318), 6.3 mm (0.25 in.) ± 0.5 mm (0.02 in.) strip length			
Screw torque, power terminals	0.565 N•m (5.0 in•lb)			
Screw torque, power terminal captive screws	0.226 N•m (2.0 in•lb)			
Screw torque, ground terminals, max	0.51 N•m (4.5 in•lb)			
Screw torque, alarm terminals, max	0.23 N•m (2.0 in•lb)			
Pilot duty rating	Alarm not rated			
Temp code	T4			

(1) Operating temperature ratings apply to switches and any compatible expansion module.

### Stratix 5800 Switches, Series B

Attribute	1783-MMS10BE Series B	1783-MMS10E Series B 1783-MMS10ER Series B	1783-MMS10 Series B 1783-MMS10R Series B	1783-MMS10A Series B 1783-MMS10AR Series B	1783-MMS10B Series B	1783-MMS10EA Series B 1783-MMS10EAR Series B
Temperature, operating <sup>(1)</sup> IEC 60068-2-1 (Test Ad, Operating Cold) IEC 60068-2-2 (Test Bd, Operating Dry Heat) IEC 60068-2-14 (Test Nb, Operating Thermal Shock)	-40 °C ≤ Ta ≤ +60 °C (-40 °F ≤ Ta ≤ +140 °F)					
Temperature, surrounding air, max	60 °C (140 °F)					
Enclosure type rating	None (open-style)					
Power input, max	12...54V DC, 5.5 A	12...54V DC, 10.6 A	12...48V DC, 4.0 A	12...48V DC, 4.4 A	12...48V DC, 2.2 A	12...54V DC, 10.7 A
Alarm relay	30V DC, 1 A, or 48V DC, 0.5 A					
Wire size, Ethernet connections	RJ45 connector according to IEC 60603-7, 2 or 4 pair Category 5e minimum cable according to TIA 568-B.1 or Category 5 cable according to ISO/IEC 24702					
Wire size, power connections, max	0.5...0.8 mm <sup>2</sup> (20...18 AWG) solid or stranded, UL/CSA-rated style 1007, or 1569 twisted-pair copper appliance wiring material (AWM) wire (such as Belden part number 9318), 6.3 mm (0.25 in.) ± 0.5 mm (0.02 in.) strip length					
Wire size, ground connection, max	4.0 mm <sup>2</sup> (12 AWG) minimum, stranded copper wire					
Wire size, alarm connections, max	0.5...0.8 mm <sup>2</sup> (20...18 AWG) solid or stranded, UL/CSA-rated style 1007, or 1569 twisted-pair copper appliance wiring material (AWM) wire (such as Belden part number 9318), 6.3 mm (0.25 in.) ± 0.5 mm (0.02 in.) strip length					
Screw torque, power terminals	0.565 N•m (5.0 in•lb)					
Screw torque, power terminal captive screws	0.226 N•m (2.0 in•lb)					
Screw torque, ground terminals, max	0.51 N•m (4.5 in•lb)					
Screw torque, alarm terminals, max	0.23 N•m (2.0 in•lb)					
Pilot duty rating	Alarm not rated					
Temp code	T4					

(1) Operating temperature ratings apply to switches and any compatible expansion module.

## Additional Resources

These documents contain additional information concerning related products from Rockwell Automation.

Resource	Description
Stratix Ethernet Device Specifications Technical Data, publication <a href="#">1783-TD001</a>	Provides specification information for Ethernet switches and other devices.
Stratix 5800 Ethernet Managed Switches User Manual, publication <a href="#">1783-UM012</a>	Provides information about configuring, monitoring, and troubleshooting the switches.
Industrial Automation Wiring and Grounding Guidelines, publication <a href="#">1770-4.1</a>	Provides general guidelines for installing a Rockwell Automation industrial system.
Product Certifications website, <a href="http://rok.auto/certifications">rok.auto/certifications</a>	Provides declarations of conformity, certificates, and other certification details.

You can view or download publications at <http://www.rockwellautomation.com/global/literature-library/overview.page>. To order paper copies of technical documentation, contact your local Allen-Bradley distributor or Rockwell Automation sales representative.

## Rockwell Automation Support

Use these resources to access support information.

<b>Technical Support Center</b>	Find help with how-to videos, FAQs, chat, user forums, Knowledgebase, and product notification updates.	<a href="http://rok.auto/support">rok.auto/support</a>
<b>Local Technical Support Phone Numbers</b>	Locate the telephone number for your country.	<a href="http://rok.auto/phonesupport">rok.auto/phonesupport</a>
<b>Technical Documentation Center</b>	Quickly access and download technical specifications, installation instructions, and user manuals.	<a href="http://rok.auto/techdocs">rok.auto/techdocs</a>
<b>Literature Library</b>	Find installation instructions, manuals, brochures, and technical data publications.	<a href="http://rok.auto/literature">rok.auto/literature</a>
<b>Product Compatibility and Download Center (PCDC)</b>	Download firmware, associated files (such as AOP, EDS, and DTM), and access product release notes.	<a href="http://rok.auto/pcdc">rok.auto/pcdc</a>

## Documentation Feedback

Your comments help us serve your documentation needs better. If you have any suggestions on how to improve our content, complete the form at [rok.auto/docfeedback](http://rok.auto/docfeedback).





## Waste Electrical and Electronic Equipment (WEEE)



At the end of life, this equipment should be collected separately from any unsorted municipal waste.

Rockwell Automation maintains current product environmental compliance information on its website at [rok.auto/pec](http://rok.auto/pec).

Rockwell Otomasyon Ticaret A.Ş. Kar Plaza İş Merkezi E Blok Kat:6 34752 İçerenköy, İstanbul, Tel: +90 (216) 5698400 EEE Yönetmeliğine Uygundur

Connect with us.    

**rockwellautomation.com** — expanding human possibility®

AMERICAS: Rockwell Automation, 1201 South Second Street, Milwaukee, WI 53204-2496 USA, Tel: (1) 414.382.2000

EUROPE/MIDDLE EAST/AFRICA: Rockwell Automation NV, Pegasus Park, De Kleetlaan 12a, 1831 Diegem, Belgium, Tel: (32) 2663 0600

ASIA PACIFIC: Rockwell Automation SEA Pte Ltd, 2 Corporation Road, #04-05, Main Lobby, Corporation Place, Singapore 618494, Tel: (65) 6510 6608

UNITED KINGDOM: Rockwell Automation Ltd., Pitfield, Kiln Farm, Milton Keynes, MK11 3DR, United Kingdom, Tel: (44)(1908) 838-800

Allen-Bradley, expanding human possibility, Rockwell Automation, and Stratix are trademarks of Rockwell Automation, Inc. Trademarks not belonging to Rockwell Automation are property of their respective companies.