

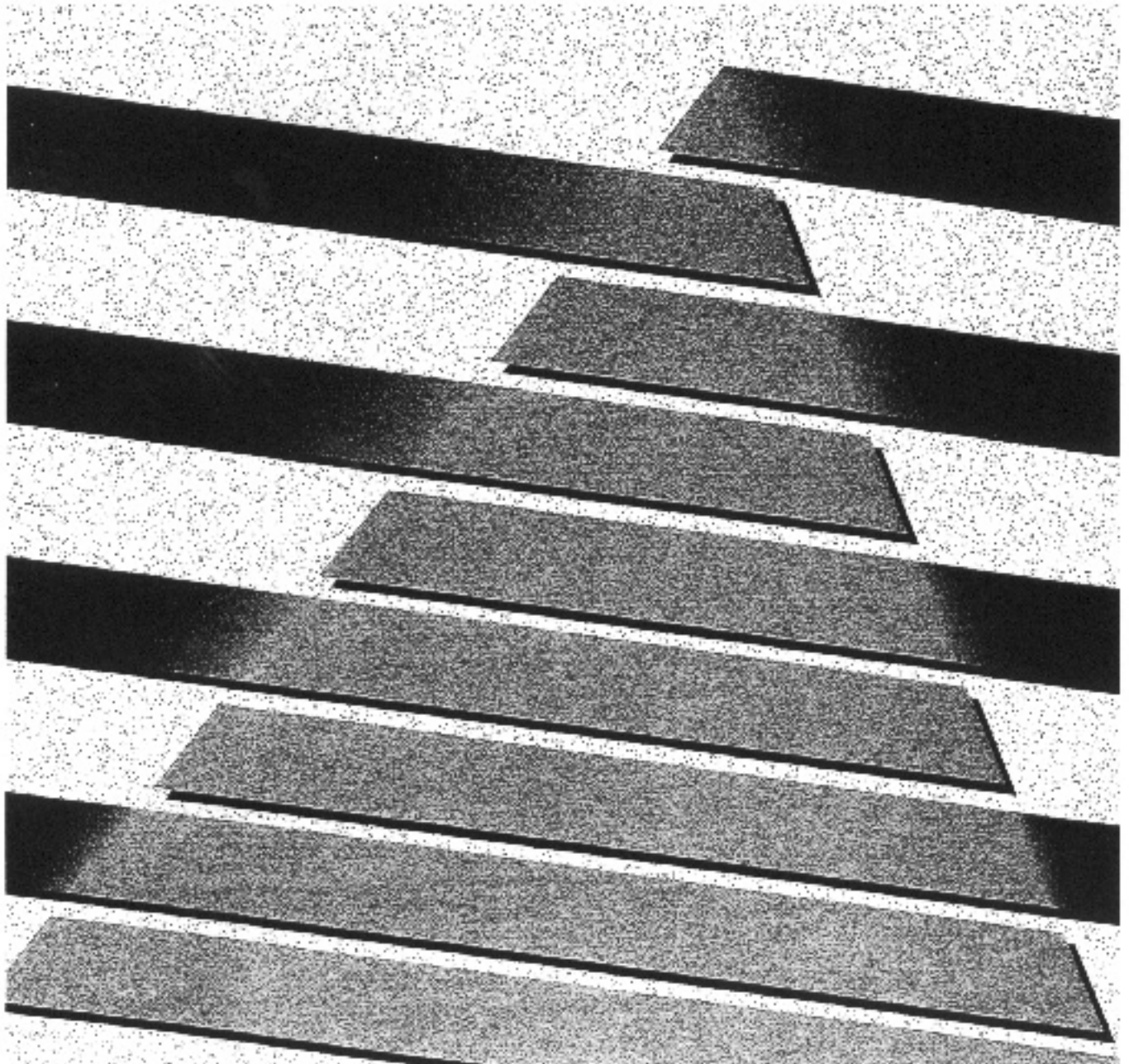

ALLEN-BRADLEY

1771-QRD Pulse Flowmeter Module

Installation and User's Manual



Important

This module is designed for use ONLY as an operating control. Where an operating control failure would result in personal injury and/or loss of property, it is the responsibility of the system designer or end user to add devices (safety, limit controls) or other systems (alarm, supervisory systems) that protect against or warn of control failure.

Solid state equipment has operational characteristics differing from those of electromechanical equipment. 'Application Considerations for Solid State Controls' (publication SGI-1.1) describes some important differences between solid state equipment and hard wired electromechanical devices. Because of this difference, and also because of the wide variety of uses for solid state equipment, all persons responsible for applying this equipment must satisfy themselves that each intended application is acceptable.

In no event will Allen-Bradley Company be responsible or liable for indirect or consequential damages resulting from the use or application of this equipment.

The examples and diagrams in this manual are included solely for illustrative purposes. Because of the many variables and requirements associated with any particular installation, Allen-Bradley Company cannot assume responsibility or liability for actual use based on the examples and diagrams.

No patent liability is assumed by Allen-Bradley Company with respect to use of information, circuits, equipment or software described in this manual.

Reproduction of the contents of this manual, in whole or part, without written permission of the Allen-Bradley Company is prohibited.

Table of Contents

| | |
|---|--------------------------|
| Before You Begin | 1 |
| Manual's Purpose | 1 |
| Audience | 1 |
| Vocabulary | 1 |
| Overview of the Manual | 1 |
| Warnings and Cautions | 2 |
| Explosion Hazard | 2 |
| Related Products | 2 |
| Product Compatibility | 3 |
| Related Publications | 3 |
| | |
| Introduction | 1 |
| Chapter Objectives | 1 |
| Module Description and General Features | 1 |
| How the 1771-QRD Works | 2 |
| How the 1771-QRD Communicates With Programmable Controllers | 3 |
| Chapter Summary | 3 |
| | |
| Installation | 1 |
| Chapter Objective | 1 |
| Installing the 1771-QRD Module | 1 |
| Power Requirements | 1 |
| Module Location in the I/O Chassis | 2 |
| Module Keying | 2 |
| | 2 |
| Wiring | 2 |
| Electrostatic Discharge | 3 |
| Module Installation | 3 |
| Indicators | 7 |
| Chapter Summary | 7 |
| | |
| Module Programming | 1 |
| Chapter Objectives | 1 |
| Reading Data From The Module | 1 |
| Overrange and Overflow | 2 |
| Block Transfer Programming | 2 |
| Example #1: PLC-5/15 Processor in a Local 1771 Backplane | 3 |
| Example #2: PLC-5/15 with Remote I/O | 8 |
| Example #3: PLC-3/10 with Remote I/O | 12 |

| | |
|---|-----------------|
| More on Overage and Overflow | <u>1</u> |
| Chapter Objectives | <u>1</u> |
| Frequency Overage Flags | <u>1</u> |
| Totalizer Overflow Flags | <u>2</u> |
| Using A Block Transfer Write to Reset the Totalizer(s) and/or Overflow Flags | <u>3</u> |
| Chapter Summary | <u>5</u> |
| | |
| Troubleshooting | <u>1</u> |
| Chapter Objectives | <u>1</u> |
| | |
| Data Formats | <u>1</u> |
| Block Transfer Write Format From PLC to QRD | <u>1</u> |
| Response from QRD to PLC Block Transfer | <u>1</u> |
| | |
| Specifications | <u>1</u> |
| Power Requirements | <u>1</u> |
| Environment | <u>1</u> |
| Agency Approval | <u>1</u> |
| Packaging | <u>1</u> |
| Weight | <u>1</u> |
| Capacity | <u>1</u> |
| Performance | <u>1</u> |
| Operational Limits | <u>2</u> |

Before You Begin

Manual's Purpose

This manual shows you how to apply the 1771–QRD Pulse Flowmeter Module to an Allen-Bradley PLC system. It describes methods for installation, programming, and troubleshooting the module. It also provides examples of how to use the module.

Audience

You must be able to program and operate an Allen-Bradley programmable controller to make efficient use of this module. In particular, you must know how to program Block Transfer instructions. If you do not, refer to the appropriate programming and operations manual for the processor you are using.

Vocabulary

We refer to the:

- Pulse Flowmeter Module (Catalog No. 1771–QRD) as “the module”, or “the QRD”.
- Programmable Controller as “the processor”.

Overview of the Manual

This manual is divided into 6 chapters. The following table provides a brief overview of the topics covered in each chapter.

| Chapter | Title | Topics Covered |
|------------|--------------------------------|---|
| 2 | Introduction | Description of module including programmable features |
| 3 | Installation | Module power requirements, keying chassis location, field wiring |
| 4 | Programming | Reading data from the module Sample programs for various processors |
| 5 | More on Overrange and Overflow | Error codes Block transfer write rung for resetting totalizers and/or overflow flags |
| 6 | Troubleshooting | Symptom/solution guide |
| Appendix A | Data Formats | Data formats fore Block Transfer Write and Block Transfer Read |
| Appendix B | Specifications | |

Warnings and Cautions

Warnings are found in this manual and on the equipment. The following symbols are used:



WARNING: A warning symbol means people might be injured if the the procedures are not followed.



CAUTION: A caution symbol is used when machinery could be damaged if the procedures are not followed. Explosion Hazard

Explosion Hazard



WARNING: Explosion hazard — substitution of components may impair suitability for Class 1. Division 2



AVERTISSEMENT: Risque d'explosion — la substitution de composants peut rendre ce matériel inacceptable pour les emplacements de Classe 1, Division 2.



WARNING: Explosion hazard — do not disconnect equipment unless power has been switched off or the area is known to be non-hazardous.



AVERTISSEMENT: Risque d'explosion — avant de déconnecter l'équipement, couper le courant ou s'assurer que l'emplacement est designe non dangereux.

Related Products

The 1771–QRD Module can be installed in any system that uses Allen-Bradley PLC–2, PLC–3 or PLC–5 Programmable Controllers with Block Transfer capability and 1771 I/O structure.

Contact your nearest Allen-Bradley office for more information about programmable controllers.

Product Compatibility

- Do not put the module in the same module group as a discrete high-density module with 2 slot addressing.
- Avoid placing the module adjacent to AC modules or high voltage DC modules.

Related Publications

Consult the Allen-Bradley Industrial Computer Group Publications Index (SD 499) for more information about programmable controllers.

Introduction

Chapter Objectives

In this chapter you will read about:

- 1771–QRD Pulse Flowmeter Module features
- How the 1771–QRD Module communicates with programmable controllers

Module Description and General Features

The Catalog No. 1771–QRD Pulse Flowmeter Module is an intelligent block transfer module that interfaces Programmable Controllers with magnetic pickups, single channel shaft encoders, and turbine flowmeters, or with any source of TTL pulses. The module is generally compatible with, but does not require the use of, turbine flowmeter signal preconditioning modules. It provides rate and count data in 2's complement binary format to the processor data table through block data transfers.

Rates as high as 10.0 kHz and counts as large as 32,767 are supported. At overflow, the count continues from zero and an overflow flag is set. The overflow flag can be reset by the ladder logic. In addition, the PLC can reset any or all counts directly.

The module functions with reduced performance in PLC–2 systems due to their three digit BCD operation. Rates as high as 0.999 kHz are permitted as are total counts of any size, provided that the PLC ladder polls the module at intervals faster than it can acquire 999 counts.

The 1771–QRD module receives +5 Vdc operating voltage through the I/O chassis backplane. It draws a maximum of 0.50 A from this supply.

The module is implemented in a 1771 single-density module form factor.

How the 1771-QRD Works

Figure 2.1
A Typical Channel

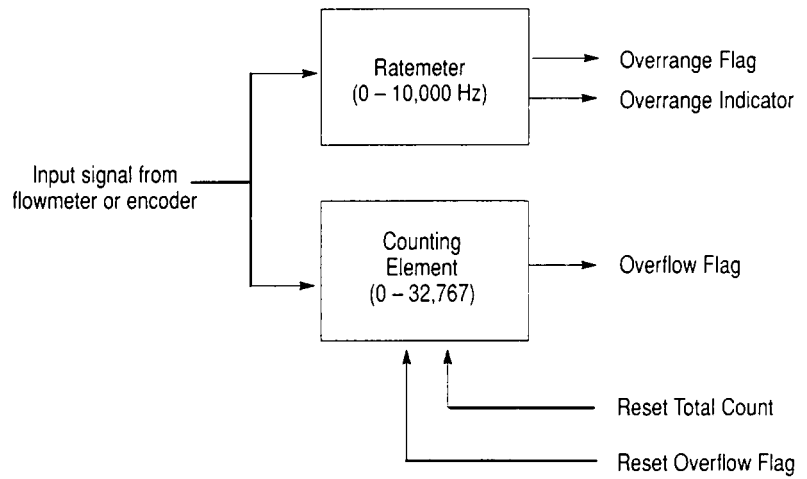

The QRD is operated with block transfers. Block Transfer Reads report the count values, rates, and both overrange and overflow flags to the PLC. Block Transfer Writes are used by the PLC to reset the total count or to reset the overflow flags.

How the 1771-QRD Communicates With Programmable Controllers

The following is a step-by-step example of the information flow to and from a 1771-QRD Module (Figure 2.2):

1. External devices (magnetic pickups, single channel encoders) generate signals that are conducted to the 1771-QRD module.
2. The 1771-QRD module converts the incoming signals into counts and rates, then stores these values until the PLC requests a transfer of data.
3. When instructed by the ladder program, the processor performs a Block Transfer Read of the values and stores them in the processor's data table.
4. In the case of a count overflow, the ladder program can sense the overflow and reset the overflow flag, if desired, using data from within a Block Transfer Write command. Any or all of the totalizers can also be reset. (Note that when the totalizers are reset the overflow flags are also reset.)
5. In the case of a rate overrange, the ladder program can sense the overrange condition and act upon it accordingly.
6. The ladder program can use and/or move the data before it is written over by the transfer of new data in a subsequent block transfer.

Figure 2.2
Information flow through a programmable controller/1771-QRD System

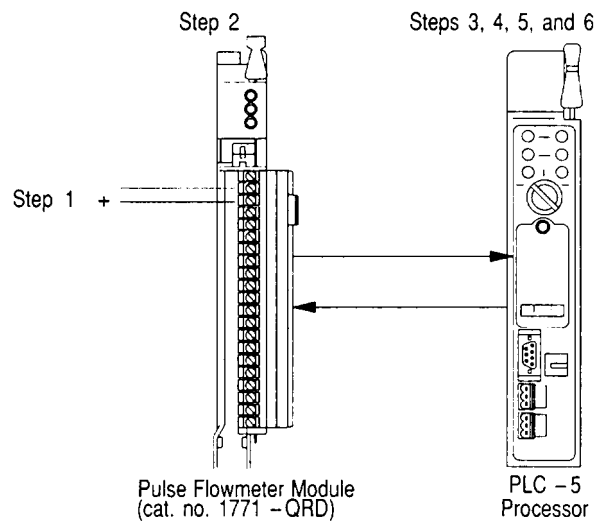

Chapter Summary

In this chapter you read about the functional aspects of the 1771-QRD Module and how it communicates with a Programmable Controller.

Installation

Chapter Objective

In this chapter you will read how to install the 1771-QRD module in the I/O chassis.

Installing the 1771-QRD Module

Read this installation section completely before installing the module. Double check all connections before you begin programming.



WARNING: Disconnect and lock out all power from the controller and system power supplies before installing and wiring modules to avoid injury to personnel and damage to equipment.

Before installing the 1771-QRD Module in the I/O chassis:

1. Calculate the power requirements of all the modules in the chassis. See the section below titled “Power Requirements”.
2. Determine the location of the module in the I/O chassis. See the section titled “Module Location in the I/O chassis”.
3. Key the backplane connectors in the I/O chassis. See the section titled “Module Keying”.
4. Connect the field wiring. See the section titled “Wiring”.

Power Requirements

The 1771-QRD Module receives its power through the 1771 I/O chassis backplane from the chassis power supply. It does not require any other external power supply to function. When planning the system, consider the power usage of all modules in the I/O chassis to prevent overloading the chassis backplane or power supply. Each 1771-QRD Module requires 0.50 A at +5VDC. Add this to the requirements of all other modules in the I/O chassis.



CAUTION: Do not insert or remove modules from the I/O chassis while system power is on. Failure to observe this rule may result in damage to the module circuitry.

Module Location in the I/O Chassis

Place the module in any I/O module slot of the I/O chassis except for the extreme left slot. This slot is reserved for the programmable controllers or adapter modules. In addition:

1. Do not put the module in the same module group as a discrete high-density module with 2-slot addressing. However, other single-slot modules may be placed in the same module group.
2. Do not put the module adjacent to AC or high voltage DC I/O modules, to minimize electrical noise and temperature effects. Noise can be minimized by grouping input and output modules together within an I/O chassis.

See the user's manual of any other intelligent I/O modules involved for possible grouping limitations.

Module Keying

Module Keying Plastic keying bands, shipped with each I/O chassis provide an easy method for keying I/O slots to accept only one type of module. The module is slotted in two places on the edge of the rear circuit board. The position of the keying bands on the backplane connector must correspond to these slots to allow insertion of the module. You can key any connector in an I/O chassis to receive this module except for the leftmost connector reserved for processor or adapter modules. Place the keying band between the following numbers labeled on the backplane connector:

- between pins 2 and 4
- between pins 6 and 8

You may change the positions of the bands if subsequent system design and rewiring makes insertion of a different type of module necessary. Use needle-nose pliers to insert or remove a keying band.

Wiring



WARNING: To avoid injury to personnel and damage to equipment, disconnect and lock out power from the processor and system power supplies before wiring the module.

Connections to/from I/O devices are made to the field wiring arm (catalog no. 1771-WG shipped with the module). Attach the wiring arm to the pivot bar at the bottom of the I/O chassis. It pivots upward and connects with the module so you can install or remove the module without disconnecting the wires.

The sensor cable must be shielded. The shield must extend the length of the cable, but be connected only at the 1771-QRD end. The recommended sensor wiring cable type is Belden 8761 or similar. The functions of the individual terminals of the field wiring arm are shown in Figure 3.1.

The wiring diagrams for both magnetic pickups and TTL are shown in Figures 3.2 and 3.3, respectively.

Electrostatic Discharge

Electrostatic Discharge Electrostatic discharge can damage the integrated circuits in this module, if you touch the backplane connector pins. Avoid electrostatic damage by observing the following precautions:

- Touch a grounded object to rid yourself of charge before handling the module.
- Do not touch the backplane connector or connector pins.
- When not in use, keep module in its static-shield bag.



CAUTION: Electrostatic discharge can degrade performance or damage the module. Handle as stated above.

Module Installation

Now that you have determined the power requirements, location, keying and wiring for the 1771-QRD Module, you are ready to install it in the I/O chassis.

1. Turn off power to the chassis.
2. Place the module in the plastic tracks on the top and bottom of the slot to guide the module into position.
3. Seat the module into the connector by applying firm, even pressure. Do not force the module into its backplane connector.
4. Snap the chassis latch over the top of the module to secure its position.
5. Connect the wiring arm to the module.
6. Turn on power to the chassis. The green “ACTIVE” light should be illuminated. If it is not lit, there is no power being applied to the module. Turn the power off, re-insert the module and try again.

Connect one or more signal sources to the 1771-QRD. The signal source can be a magnetic pickup/turbine flowmeter or TTL pulses.

Figure 3.1
Field Wiring Arm

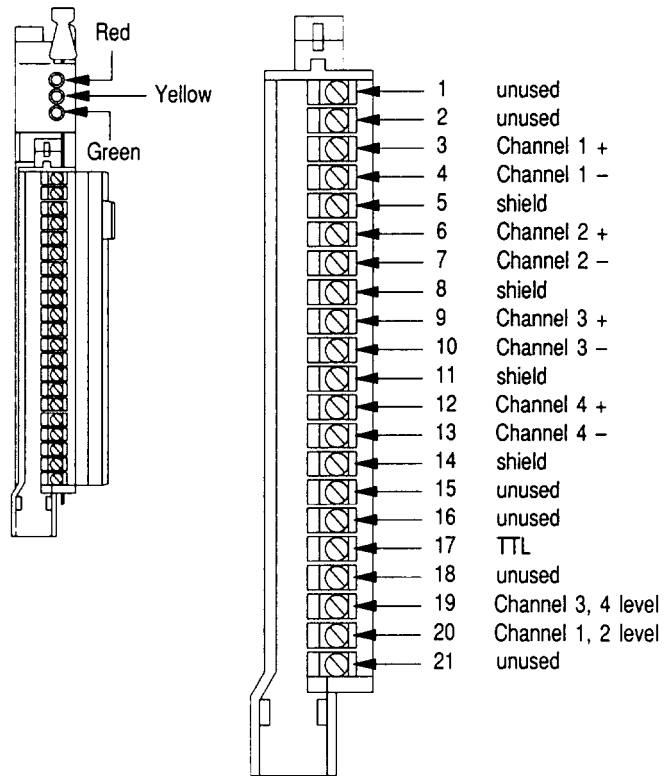

18322



WARNING: Explosion hazard. Do not disconnect equipment unless power has been switched off or the area is known to be nonhazardous.



AVERTISSEMENT: Risque d'explosion. Avant de déconnecter l'équipement, couper le courant ou s'assurer que l'emplacement est désigné non dangereux.

Figure 3.2
Wiring for Pickups or Flowmeters

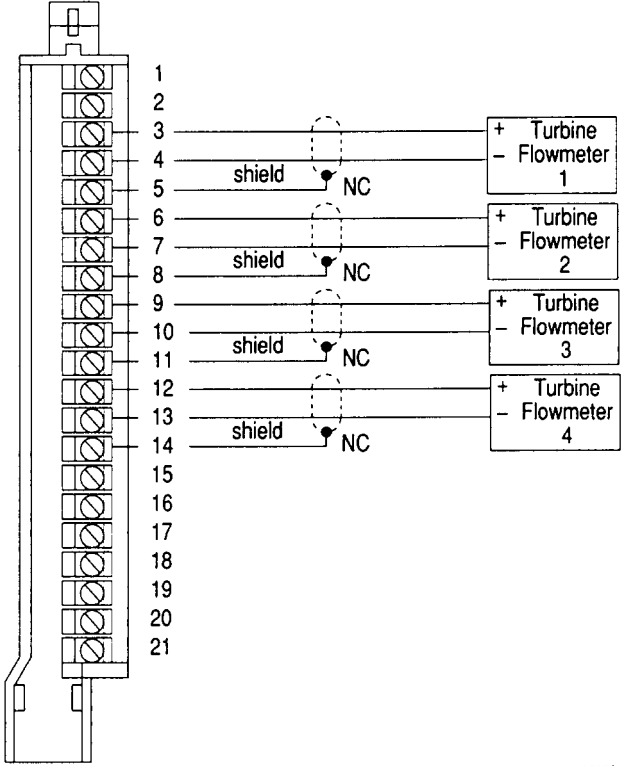

18323

Figure 3.3
Wiring for Active TTL Drivers

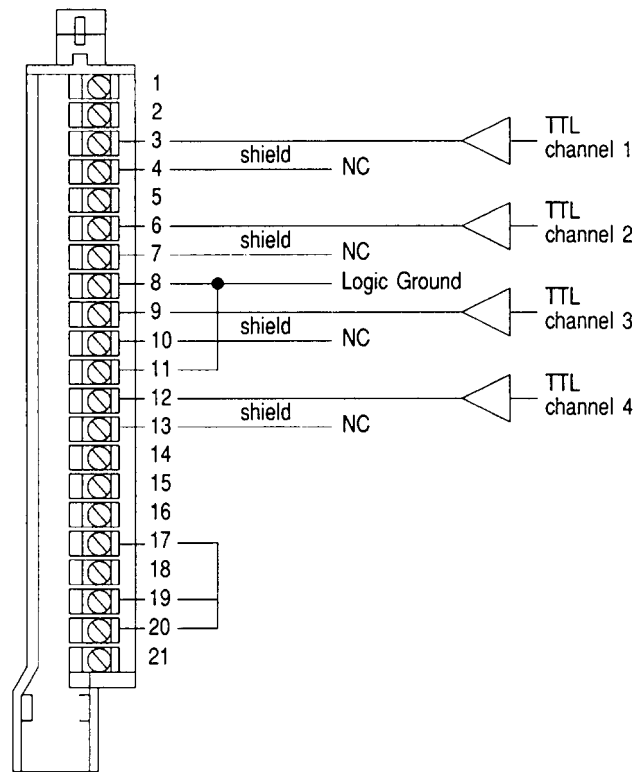

18324

Note: The jumper between terminals 17 and 19 changes the sensitivity of channels 3 and 4 so that they are compatible with TTL pulses.

The jumper between terminals 17 and 20 changes the sensitivity of channels 1 and 2 so that they are compatible with TTL pulses.

Signal types may not be mixed within a channel pair.

For use with magnetic pickups or turbine flowmeters, do not connect a jumper to these terminals.



WARNING: Remove power from the 1771 I/O chassis backplane and from the wiring arm before removing or installing the module.

- Failure to remove power from the backplane or the wiring arm could cause module damage, degradation of performance or injury.
- Failure to remove power from the backplane could cause injury or equipment damage due to possible unexpected operation.

Indicators

There are three indicator LEDs on the front panel. The indicator LED functions are listed in Table 3.A.

Table 3.A
Indicators

| Legend | Color | Type | Function |
|--------|--------|----------|---|
| FAULT | Red | Solid | One or more inputs are above 10.0 kHz |
| FAULT | Red | Flashing | Internal hardware failure, or input rates drifting above and below 10.0 kHz |
| PROG | Yellow | Flashing | Block transfer in process |
| ACTIVE | Green | Solid | Module active |

Chapter Summary

In this chapter you read how to install the 1771-QRD Module in a Programmable Controller system, as well as how to wire the field wiring arm.

Module Programming

Chapter Objectives

In this chapter you will learn about:

- Reading data from the 1771-QRD module
- Writing data to the 1771-QRD module
- Block transfer programming format
- Programming techniques

Reading Data From The Module

Block Transfer Read programming moves 9 words from the 1771-QRD Module to the processor's data table. The ladder program initiates the request to transfer data from the QRD to the processor.

Figure 4.1 illustrates the module's response after the PLC processor's block transfer request for counts and rates.

Figure 4.1
Module's Response to Block Transfer Read Request

| | | | | |
|--------|-----------------|---|---|---|
| Word 0 | 1 | 0 | 0 | 0 |
| Word 1 | Channel 1 Rate | | | |
| Word 2 | Channel 1 Total | | | |
| Word 3 | Channel 2 Rate | | | |
| Word 4 | Channel 2 Total | | | |
| Word 5 | Channel 3 Rate | | | |
| Word 6 | Channel 3 Total | | | |
| Word 7 | Channel 4 Rate | | | |
| Word 8 | Channel 4 Total | | | |

Word 0 (1000) is the header code that identifies the data source as a 1771-QRD module. When the module is active, it also contains the status of the overrange and overflow flags. Overrange and overflow are discussed in more detail in the next section of this chapter. Word #1 contains the rate of the signal on channel 1; word #2 contains the total number of pulses received on channel 1. Word #3 contains the rate of the signal on channel 2; word #4 contains the total number of pulses received on channel 2. Word #5 contains the rate of the signal on channel 3; word #6 contains the total number of pulses received on channel 3. And finally, words #7 and #8 contain the rate and total number of pulses received on channel 4, respectively.

Overrange and Overflow

The 1771-QRD processes input signals at a maximum rate of 10.0kHz. If the rate of the incoming signal on any channel is greater than 10.0 kHz, the red FAULT indicator will illuminate, revealing an overrange. At the same time, a bit will be set in the acknowledge word (word 0), showing the channel(s) whose rate is in an overrange condition. The red FAULT light will extinguish only when the frequency of the input that is causing the overrange is reduced to less than 10.0 kHz. At that time, the FAULT light will go out, and the overrange flag for that channel will automatically be reset. Overrange rates are reported as zero values, and cause their totalizers to reset to zero.

The 1771-QRD also acts as a totalizer for each of the channels. Each of the totalizers is capable of counting up to 32,767. When this number is reached by any of the totalizers, an overflow flag for that channel is set in the acknowledge word. The counter will again start from zero and continue to count, with the overflow flag set. These flags can be detected by the processor, and any or all of them can be reset using a Block Transfer Write command. Examples of the detection and handling of overflow conditions with a BTW command are discussed further in Chapter 5.

Block Transfer Programming

The following sections show how to program and set up typical programmable controllers for use with the 1771-QRD Module. In each example, the switch settings for all of the processors and adapters used are given, as well as the backplane settings for the I/O chassis. Note that 2-slot addressing is used in all of these examples, but the 1771-QRD will function with any type of addressing (2-slot, 1-slot, 1/2-slot).

The following table outlines the examples that are contained in this chapter:

Table 4.A
Examples Contained in This Section

| Example Number | System Type | Page |
|----------------|------------------------------------|------|
| 1 | PLC-5/15 in a local 1771 backplane | 4-3 |
| 2 | PLC-5/15 with Remote I/O | 4-8 |
| 3 | PLC-3/10 with Remote I/O | 4-12 |

These examples represent the most common configurations for a controller system. One of them should be close enough to your application to be used as a guide.

**Example #1: PLC-5/15
Processor in a Local 1771
Backplane**

1. Install the 1771-QRD module in a 1771 backplane. Figure 4.2 illustrates a PLC-5/15 configured for 2-slot addressing.

Figure 4.2
2-Slot Addressing Configuration Example

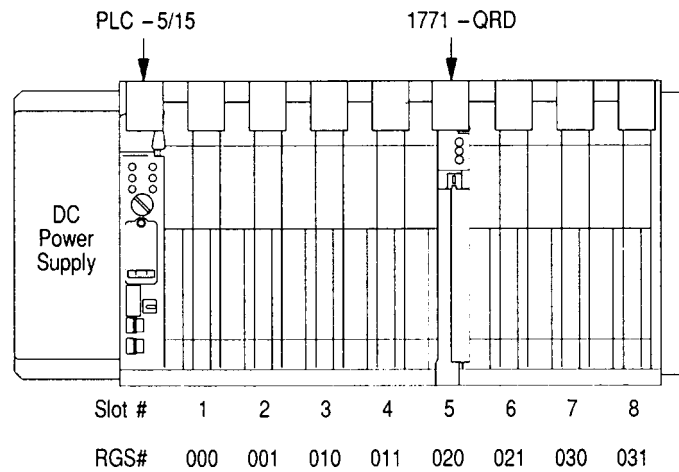

The eight physical slots labeled with Rack/Group/Slot (RGS) addresses in Figure 4.2 would have different RGS addresses if single or 1/2 slot addressing were chosen.

Please refer to Figure 4.3 for dual, single, or 1/2 slot addressing RGS numbers.



WARNING: Remove system power and power to all devices connected to the swing arm terminals before removing or installing your module into the 1771 I/O chassis. Failure to observe this warning could result in damage to the module circuitry and/or undesired operation with possible injury to personnel.

Figure 4.3
Dual, Single and Half Slot Addressing for Rack 0

| Dual-Slot | | Single-Slot | | Half-Slot | |
|-------------|-----|-------------|-----|-------------|-----|
| Slot Number | RGS | Slot Number | RGS | Slot Number | RGS |
| 1 | 000 | 1 | 000 | 1 | 000 |
| 2 | 001 | 2 | 010 | 2 | 020 |
| 3 | 010 | 3 | 020 | 3 | 040 |
| 4 | 011 | 4 | 030 | 4 | 060 |
| 5 | 020 | 5 | 040 | 5 | 100 |
| 6 | 021 | 6 | 050 | 6 | 120 |
| 7 | 030 | 7 | 060 | 7 | 140 |
| 8 | 031 | 8 | 070 | 8 | 160 |

2. Set the PLC-5/15 configuration switches as shown in Figure 4.4.

Figure 4.4
PLC-5/15 Configuration Dip Switches

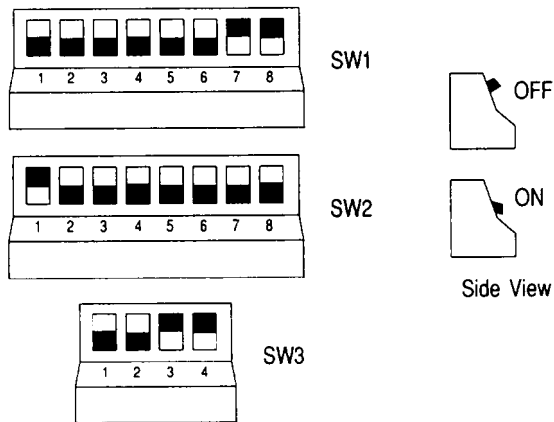

NOTE: The black area indicates the selected switch position (up or down).

3. Set the 1771 backplane dip switch as shown in Figure 4.5.

Figure 4.5
1771 Backplane Dip Switch.

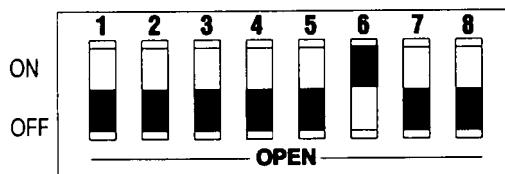

NOTE: The black area indicates where the switch should be pressed with a pencil or other sharp instrument.

The backplane is now set up for 2 (dual) slot addressing.

- Apply power to the I/O chassis. Enter the Block Transfer rung shown in Figure 4.6 into the PLC-5/15 processor.

Figure 4.6
Block Transfer Rung for a PLC-5/15 Processor

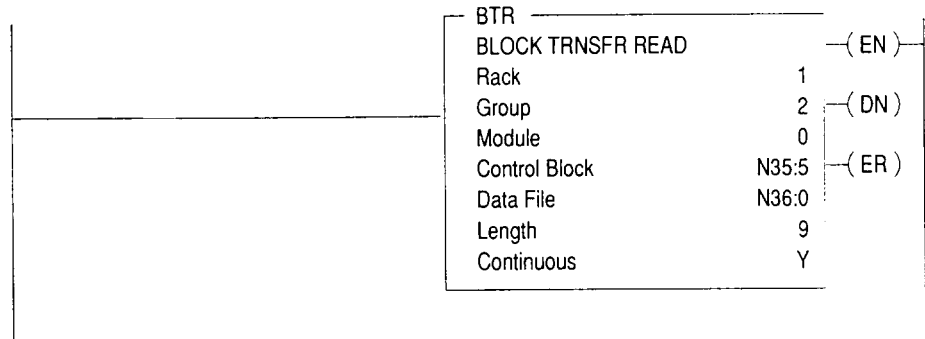

NOTE: If the module is installed in a physical slot other than the fifth slot to the right of the PLC processor, the BTR block will have to be set up with a Rack/Group/Slot address other than 020. Refer to Figure 4.3 for the correct address settings.

- Place the PLC-5/15 processor into RUN mode.

Use the Data Monitor in the 6200 Series Software to examine data table address N36:0. This is where the processor has stored the rates and total counts received from the 1771-QRD.

| ADDRESS N36:0 | 0 | 1 | 2 | 3 | 4 | 5 | 6 | 7 | 8 | 9 |
|------------------|------|-------------------|--------------------|-------------------|--------------------|-------------------|--------------------|-------------------|--------------------|------|
| ACKNOWLEDGE CODE | 1000 | | | | | | | | | 0000 |
| | | 260D | 2A37 | 260E | 2222 | 260D | 0412 | 260C | 1432 | |
| | | CHANNEL 1 RATE | | CHANNEL 2 RATE | | CHANNEL 3 RATE | | CHANNEL 4 RATE | | |
| | | | CHANNEL 1 TOTAL | | CHANNEL 2 TOTAL | | CHANNEL 3 TOTAL | | CHANNEL 4 TOTAL | |

Only the channels which are actually driven will be active.

If all four input channels are being driven, we see that the value that appears at address #1 is the rate of the signal that appears at swingarm terminals 3 and 4. Note that the value that appears at address #3 is the rate of the signal that appears at swingarm terminals 6 and 7; the value appearing at address #5 is the rate of the signal that appears at swingarm terminals 9 and 10; and finally, the value that appears at address #7 is the rate of the signal that appears at swingarm terminals 12 and 13. The totals for each of the channels appear to the right of their respective rates; i.e. channel 1 rate (word #1) is accompanied by channel 1 total (word #2); Channel 2 rate (word #3) is accompanied by channel 2 total (word #4); Channel 3 rate (word #5) is accompanied by channel 3 total (word #6); and channel 4 rate (word #7) is accompanied by channel 4 total (word #8). The acknowledgement code of 1000 (in word 0) identifies the module as 1771-QRD Pulse Flowmeter Module.

**Example #2: PLC-5/15 with
Remote I/O**

1. Install the module in the remote 1771 backplane, as shown in Figure 4.7.

Figure 4.7
PLC-5/15 in a Local Backplane With an ASB in a Remote Backplane

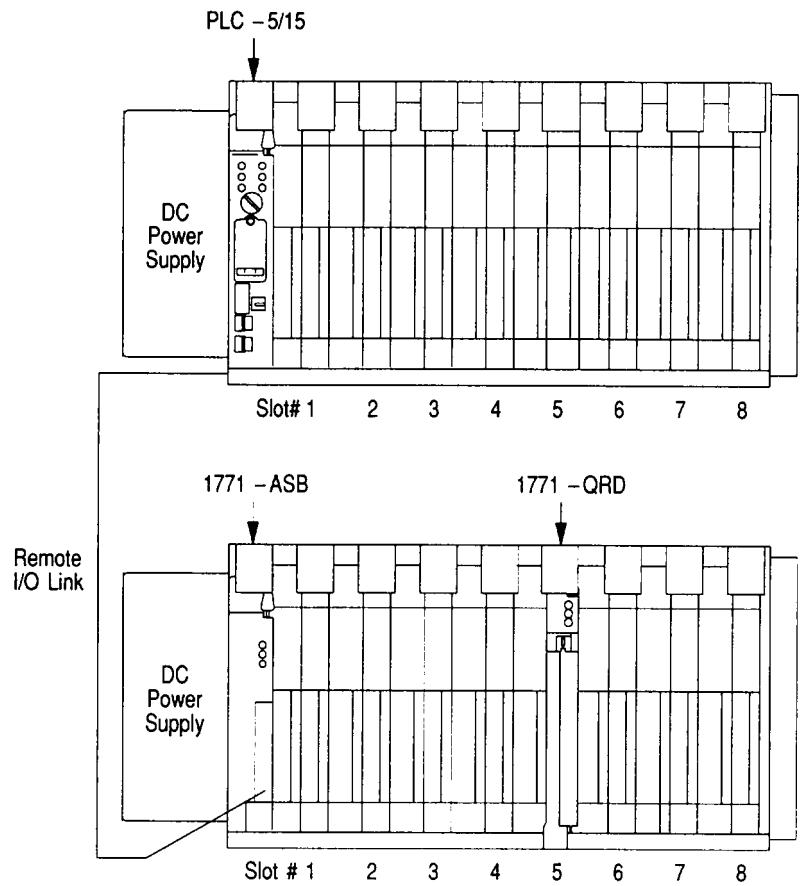

18328

2. Set the PLC-5/15 configuration dip switches, as shown in Figure 4.8.

Figure 4.8
PLC-5/15 Configuration Dip Switches

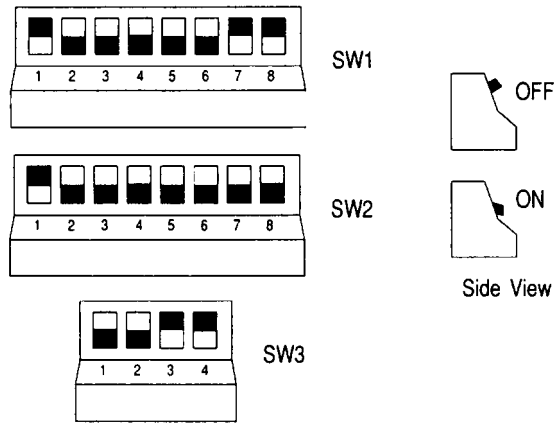

NOTE: The black area indicates the selected switch position (up or down).

3. Set the 1771 Backplane dip switch, as shown in Figure 4.9.

Figure 4.9
Backplane Dip Switches

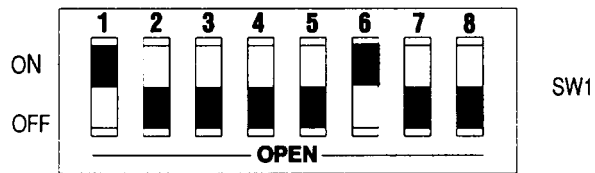

NOTE: The black area indicates where the switch should be pressed with a pencil or other sharp instrument.

The local chassis is now configured for 2-slot addressing.

4. Set the 1771-ASB configuration switches, as shown Figure 4.10.

Figure 4.10
1771-ASB Configuration Dip Switches

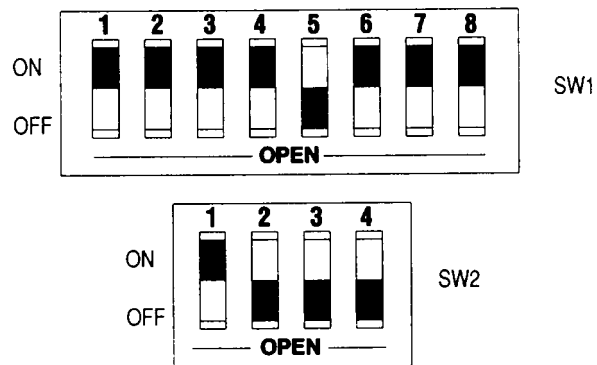

NOTE: The black area indicates where the switch should be pressed with a pencil or other sharp instrument.

5. Set the remote 1771 backplane dip switch, as shown in Figure 4.11.

Figure 4.11
1771 Remote Backplane Dip Switch

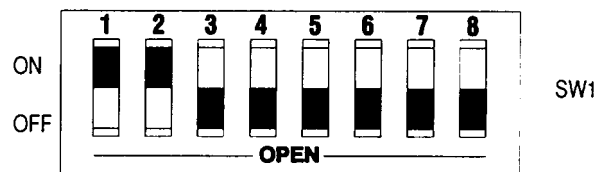

NOTE: The black area indicates where the switch should be pressed with a pencil or other sharp instrument.

The remote chassis is now configured for 2-slot addressing.

- Enter the Block Transfer Rung found in Figure 4.12 into the PLC-5/15.

Figure 4.12
Block Transfer Rung for a PLC-5/15 With Remote I/O

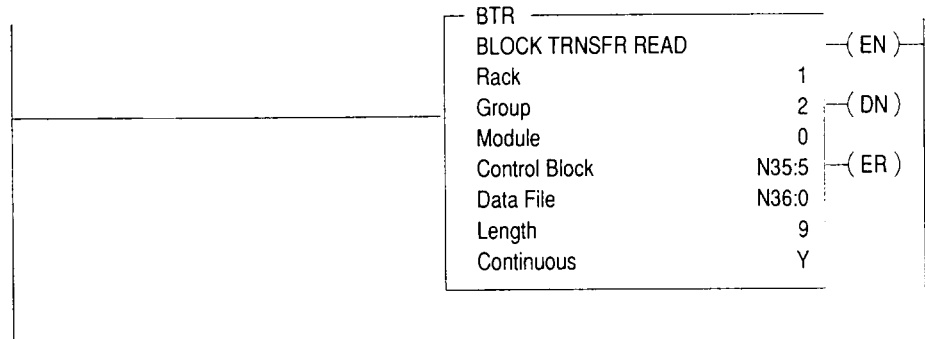

- Place the PLC-5/15 Processor in RUN mode.

Use the DATA MONITOR to examine data table address N36:0. This is where the QRD has stored the data from the four channels. They will appear as:

| ADDRESS | 0 | 1 | 2 | 3 | 4 | 5 | 6 | 7 | 8 | 9 |
|------------------|------|----------------|-----------------|----------------|-----------------|----------------|-----------------|----------------|-----------------|------|
| N36:0 | 1000 | 260D | 2A37 | 260E | 2222 | 260D | 0412 | 260C | 1432 | 0000 |
| ACKNOWLEDGE CODE | | CHANNEL 1 RATE | | CHANNEL 2 RATE | | CHANNEL 3 RATE | | CHANNEL 4 RATE | | |
| | | | CHANNEL 1 TOTAL | | CHANNEL 2 TOTAL | | CHANNEL 3 TOTAL | | CHANNEL 4 TOTAL | |

Only the channels which are actually driven will be active.

**Example #3: PLC-3/10 with
Remote I/O**

1. Install the module in the remote 1771 backplane, as shown in Figure 4.13.

Figure 4.13
PLC-3/10 with an ASB in a Remote Backplane

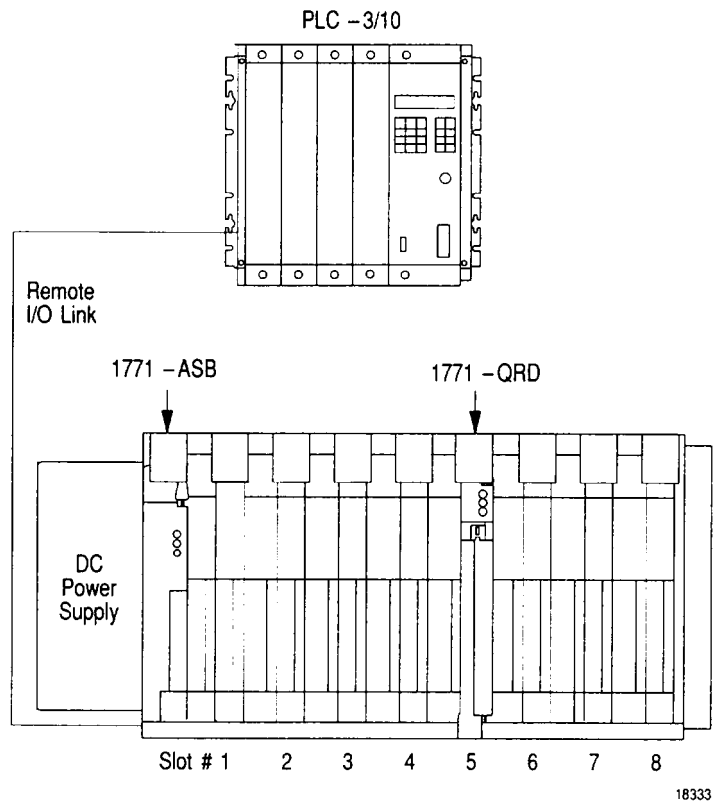

18333

2. Set the 1771-ASB configuration switches, as shown in Figure 4.14.

Figure 4.14
1771-ASB Configuration Dip Switches

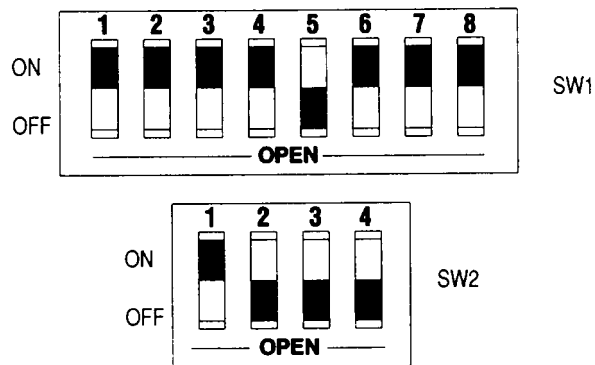

NOTE: The black area indicates where the switch should be pressed with a pencil or other sharp instrument.

3. Set the 1771 Remote Backplane dip switch, as shown in Figure 4.15.

Figure 4.15
1771 Remote Backplane Dip Switch

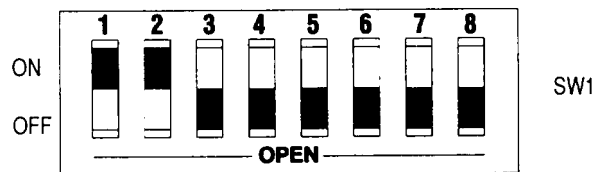

NOTE: The black area indicates where the switch should be pressed with a pencil or other sharp instrument.

The remote chassis is now configured for 2-slot addressing.

- Enter the Block Transfer Rung found in Figure 4.16 into the PLC-3/10 processor.

Figure 4.16
Block Transfer Rung for a PLC-3/10 with Remote I/O

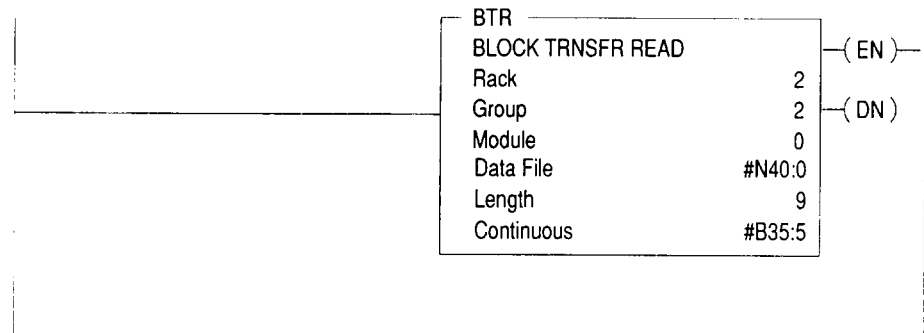

- Place the PLC-3/10 Processor in RUN mode.

Use the DATA MONITOR to examine data table address #N40:0. This is where the QRD has stored the rates from the four channels.

| ADDRESS | 0 | 1 | 2 | 3 | 4 | 5 | 6 | 7 | 8 | 9 |
|------------------|------|----------------|-----------------|----------------|-----------------|----------------|-----------------|----------------|-----------------|------|
| N36:0 | 1000 | 260D | 2A37 | 260E | 2222 | 260D | 0412 | 260C | 1432 | 0000 |
| ACKNOWLEDGE CODE | | CHANNEL 1 RATE | | CHANNEL 2 RATE | | CHANNEL 3 RATE | | CHANNEL 4 RATE | | |
| | | | CHANNEL 1 TOTAL | | CHANNEL 2 TOTAL | | CHANNEL 3 TOTAL | | CHANNEL 4 TOTAL | |

Only the channels which are actually driven will be active.

More on Overrange and Overflow

Chapter Objectives

In this chapter you will learn more about the overrange and overflow status flags sent from the QRD to the PLC. You will also learn how to use a Block Transfer Write to clear the overflow bits, the totalizers or any combination of both.

Frequency Overrange Flags

As discussed in Chapter 4, an overflow occurs when the value of any of the four totalizers exceeds the maximum value of 32,767. At that time, an overflow flag for that channel is set and can be seen in the first word of the Block Transfer data table. These overflow flags can be reset by the ladder logic. Any or all of the totalizers can also be reset either independently of each other, or they can all be reset simultaneously.

When it detects an overflow, the 1771-Q RD sets an overflow flag in the acknowledge word (word 000) of the Block Transfer Read response. The best way to understand this concept is to break down the acknowledge word into bit format. The 16 bits are grouped by function into four categories (Figure 5.1):

Figure 5.1
Acknowledge Word (From 1771-QRD Module)

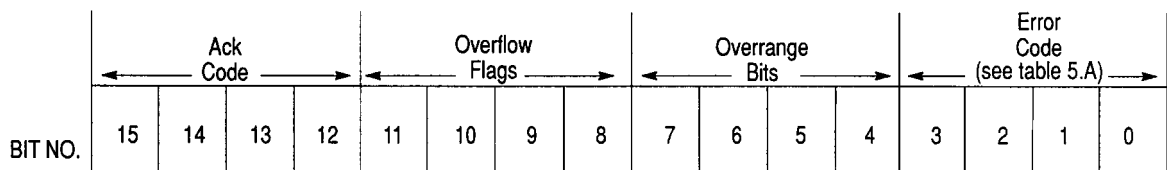

Table 5.A
Error Codes from Acknowledge Word

| Code | Meaning |
|------|-------------------------------------|
| 0 | Valid Data |
| 1 | Channel Pair Fault |
| 2 | BLOCK TRANSFER Syntax Error |
| 4 | Channel Pair Fault and Syntax Error |

Each time an input for one (or more) of the channels is greater than 10.0 kHz, the overrange flag for that channel is set; for example, if the input frequency for channel 1 is greater than 10.0 kHz, bit #4 is set. (This is the first bit of the overrange group.)

Acknowledge Word = 1010 = 0001 XXXX XXX1 0000



If the input frequency for any other channel is greater than 10.0 kHz, the QRD sets the appropriate bit in the acknowledge code. It is possible for all channels to be in an overrange condition; in such a case, the acknowledge code would be:

Acknowledge Word = 10F0 = 0001 XXXX 1111 0000

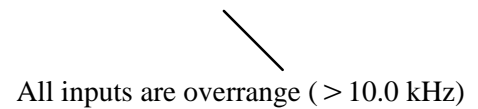

Totalizer Overflow Flags

The overflow flags work in the same manner as the overrange flags. As an example, when totalizer #1 has reached its maximum (32,767), an overflow flag (bit #8) is set in the acknowledge code. If the acknowledge code is put in binary format, it looks like this:

Acknowledge Code = 1100 = 0001 XXX1 XXXX 0000



Any or all of the four channels can overflow, and any or all of the overflow flags can be reset using a Block Transfer Write command. If all of the channels overflow, the acknowledge code will look like:

Acknowledge Code = 1F00 = 0001 1111 XXXX 0000

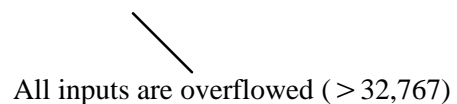

Using A Block Transfer Write to Reset the Totalizer(s) and/or Overflow Flags

Any or all of the totalizers and overflow flags can be reset using a Block Transfer Write command sent to the 1771-QRD from the PLC. For a PLC-5 processor, the rung might look like this:

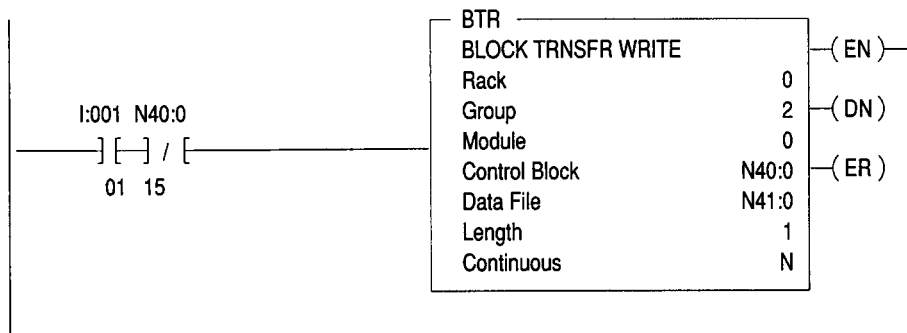

The Block Transfer Write sends the 1771-QRD one word that contains the correct bit pattern to reset the totalizer(s) and/or overflow flags. The BTW data word can be changed through the ladder logic, or by editing the data table.

Note that the Block Transfer Write is switch selectable, and its length is one word. The block transfer should only be sent once unless the ladder intelligently sets and clears the reset bits within the Block Transfer data. As an example, the ladder might set the reset bit at the time of overflow. If the Block Transfer is sent continuously and the reset bits contained within the Block Transfer data are simply left set to “1”, the transfers will constantly be resetting the totalizer(s) and/or overflow flags of the specified channels.

The word from the block transfer data table would appear in the DATA MONITOR as:

N41:0 00XX

Where: “XX” are the 8 bits used to reset the totalizer(s) and/or overflow bits.

Breaking down the word in the data table into binary format:

N41:0 0000 0000 XXXX XXXX
 4 3 2 1 4 3 2 1

To reset overflow flags To reset totalizers

The numbers underneath the “X” ’s are the channel numbers that are affected when the corresponding bit is a “1”. Note that a “1” resets the totalizer(s) and/or overflow bits, and a “0” leaves them unchanged.

NOTE: Resetting the totalizer(s) will automatically reset its respective overflow flag(s).

Figure 5.2
Example of Detecting and Resetting an Overflow Flag on Channel 1

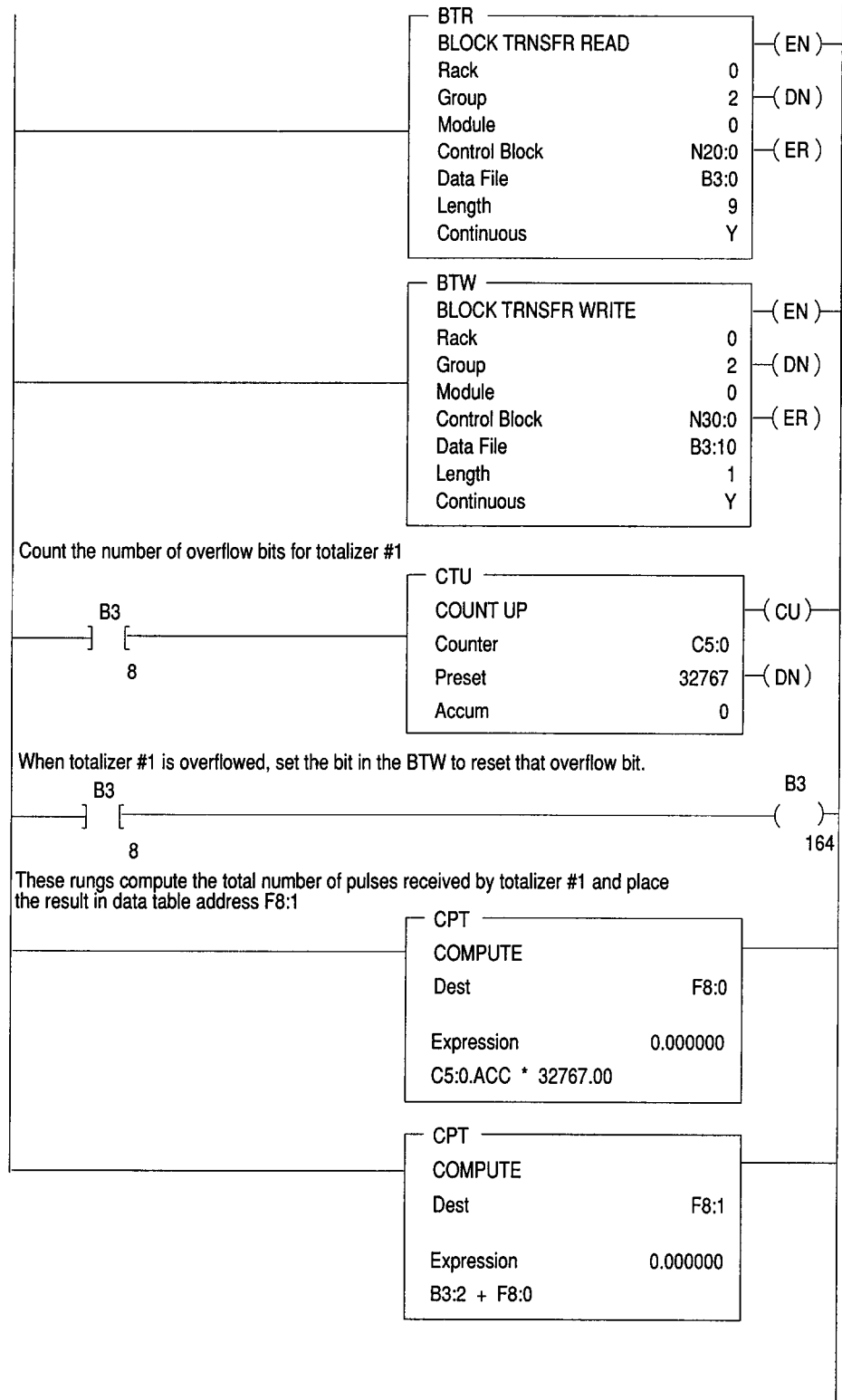

The example in Figure 5.2 detects a count overflow on Channel 1, and resets the overflow bit for that channel with a Block Transfer Write command. The ladder logic also keeps track of the total number of counts received at the channel 1 inputs.

A similar ladder could reset the overflow bits for channels 2, 3, and 4 by setting bits 165, 166, and 167 of data table B3. The actual totals for the four channels could be reset by setting bits 160, 161, 162, and 163 of data table B3.

Although not shown in the previous examples, it is good PLC-5 programming procedure to include a rung to reset the EN bit of a block transfer control file when the ER bit is set, when continuous transfers are used.

Chapter Summary

In this chapter, you learned the structure of the acknowledge code sent from the QRD and how to reset the totalizer(s) and/or the overflow flags. You also learned about the overrange condition, and how to detect it. Finally, you learned the structure of the Block Transfer Write command that is sent to the QRD Module for resetting overflow flags and/or totalizer(s).

Troubleshooting

Chapter Objectives

The following table may be used to identify the probable cause of difficulties with the 1771-QRD Module during initial installation.

| Symptom | Probable Causes | Possible Solutions |
|---|---|--|
| No indicators lit | Power not applied | Check that power supply is turned on |
| Green light off | Power not applied | Firmly reseal module in backplane |
| Red, green indicators solid, yellow indicator flashing | Rate overrange | Decrease input frequencies Check connection of cable shield(s) Move signal cable away from electrical noise sources |
| Yellow light off | Wrong rack, group, slot address used in block transfer rung Processor in Program Mode Wrong address setting on chassis switches | Verify correct address in ladder rung for block transfer (See table 4.3) Set to run mode Verify chassis switch settings |
| No block transfer writes done | Wrong rack, group, slot address Wrong address setting on chassis switches | Verify correct address in ladder rung for block transfer (See table 4.3) Verify chassis switch settings |
| No block transfer reads done | Wrong rack, group, slot address Wrong address setting on chassis switches | Verify correct address in ladder rung for block transfer (See table 4.3) Verify chassis switch settings |
| All zeros in data table, red, green indicators solid, yellow indicator flashing | Frequency overrange | Decrease input frequencies Check connection of cable shield(s) Move signal cable away from electrical noise sources |
| Data table values not being incremented; no rate | Wrong signal type or low signal voltage | Verify jumpers between terminals 17 and 19, and/or terminals 17 and 20 on the swingarm. Jumper is ONLY used for TTL signals. Verify input voltage levels |

| Symptom | Probable Causes | Possible Solutions |
|--|-----------------------------------|--|
| Data counts to small value, then jumps to zero | Continuous BTW Reset | Check ladder program to be sure that the block transfer write is not causing continuous resets of the totalizer(s) |
| Rates and counts from one input appear in more than one channel position in the data table | Wiring reversal of + and - inputs | Refer to wiring diagrams |

Data Formats

Block Transfer Write Format From PLC to QRD

Use this block format to reset totalizer(s) and/or overflow flag(s).

Note: b8 through b15 are unused.

| | | | | | | | |
|---------------|---------------|---------------|---------------|-------|-------|-------|-------|
| b7 | b6 | b5 | b4 | b3 | b2 | b1 | b0 |
| RESET | RESET | RESET | RESET | RESET | RESET | RESET | RESET |
| CH 4 | CH 3 | CH 2 | CH 1 | CH4 | CH3 | CH2 | CH1 |
| Overflow Flag | Overflow Flag | Overflow Flag | Overflow Flag | TOTAL | TOTAL | TOTAL | TOTAL |

Where: “1”=reset

“0” = not reset

Response from QRD to PLC Block Transfer

| | | | | | | | | |
|---|----------------|---------------|----------------|---------------|---------------|-----------------|----------------|---------------|
| first word | second word | third word | fourth word | fifth word | sixth word | seventh word | eighth word | ninth word |
| RESPONSE CODE AND ERROR CODE (1XYZ) | CH 1 RATE | CH 1 TOTAL | CH 2 RATE | CH 3 TOTAL | CH 3 RATE | CH 4 TOTAL | CH 4 RATE | CH 4 TOTAL |

Notes:

The digit in the response/error code labeled “Z” will adhere to the following definitions:

| Code | Meaning |
|------|-------------------------------------|
| 0 | Valid data |
| 1 | Channel pair default |
| 2 | BLOCK TRANSFER syntax error |
| 3 | Channel pair fault and syntax error |

The digit in the response/error code labeled “Y” will adhere to the following definitions:

| b7 | b6 | b5 | b4 |
|-----------|-----------|-----------|-----------|
| channel | channel | channel | channel |
| 4 rate | 3 rate | 2 rate | 1 rate |
| overrange | overrange | overrange | overrange |

“1” indicates overrange

“0” indicates not overrange

Note that the overrange condition causes both the rate and total to be zeroed

The digit in the response/error code labeled “X” will adhere to the following definitions:

| b11 | b10 | b9 | b8 |
|----------|----------|----------|----------|
| channel | channel | channel | channel |
| 4 total | 3 total | 2 total | 1 total |
| overflow | overflow | overflow | overflow |
| flag | flag | flag | flag |

“1” indicates totalizer has overflowed

“0” indicates totalizer has not overflowed

Important: When the totalizer overflows, it continues to count unless manually reset.

Specifications

Power Requirements

DC Supply Voltage from Backplane: 5 Volts \pm 5% @ 0.50 A Maximum

Note: This supply must meet the Allen-Bradley series B power bus specification. Typical supplies are 1771-P3, -P4, -P5, and -P7.

Isolated Field Supply Required: none

Environment

Operating Temperature: 0 degrees C to 60 degrees C

Storage Temperature: minus 40 degrees C to 85 degrees C

Operating Humidity: 5% – 95 % relative (non-condensing)

Agency Approval

UL (Pending), CSA Class I, Division 2, Group D

Packaging

Single slot 1771 I/O module, 21 terminals, swing arm connector

Weight

1.0 lb (approximately)

Capacity

Hardware channels per module: 4

Independent ratemeters per module: 4

Independent totalizers per module: 4

Performance

Ratemeter update time: 1.0 Second

Block transfer time: Less than 10 mS

Note: Ladders longer than 10 mS or STI files with repeat intervals longer than 10 mS will receive updated totals once per scan or STI.

Operational Limits

Signal Characteristics, Turbine Flowmeter or Magnetic Pickup: 50 mV to 142 VAC RMS

The signal should be approximately sinusoidal and must be AC. The signal must be greater than 50 mV peak to peak, and must be smaller than 400 V peak to peak.

Signal Characteristics, TTL: 1.3 V threshold

The signal should be DC pulses with width greater than 20 μ S. The logic “1” level must be greater than +1.3 V and smaller than +200 V while the logic “0” level must be larger than -0.7 V and smaller than +1.3V.

The TTL mode is compatible with TTL, 4,000 series CMOS, and most 0–24 V systems. The TTL mode is not compatible with any signal format with DC pulses riding on a fixed DC level greater than +1.3 V.

Note: Signal type is selectable by swing arm jumper. Channel thresholds are jumpered in pairs.

Input Impedance: 5 k Ω \pm 30% resistive, minimum

Isolation: 1000 V minimum between channels and microcontroller, and between channel pairs

Accuracy: 0.1% \pm 1 Hz for frequency < 3.0 kHz 0.2% \pm 1 Hz for frequency > 3.0 kHz

Overrange Indication: Individual bit for each channel set to indicate rate above 10 kHz

Overflow Indication: Individual bit for each channel set to indicate total above 32,767

Overrange Response: When a channel signal exceeds 10 kHz the rate overrange bit will be set, the total reset to zero, and the rate for that channel reported as zero

Maximum Operating Frequency: 10.0 kHz for PLC–3 and PLC–5, 0.999 kHz for PLC–2 (New Use)

Total Control: Overflow bit and total can be cleared by ladder logic. Clearing total also clears overflow bit



ALLEN-BRADLEY
A ROCKWELL INTERNATIONAL COMPANY

As a subsidiary of Rockwell International, one of the world's largest technology companies — Allen-Bradley meets today's challenges of industrial automation with over 85 years of practical plant-floor experience. More than 11,000 employees throughout the world design, manufacture and apply a wide range of control and automation products and supporting services to help our customers continuously improve quality, productivity and time to market. These products and services not only control individual machines but integrate the manufacturing process, while providing access to vital plant floor data that can be used to support decision-making throughout the enterprise.

With offices in major cities worldwide

**WORLD
HEADQUARTERS**
Allen-Bradley
1201 South Second Street
Milwaukee, WI 53204 USA
Tel: (1) 414 382-2000
Telex: 43 11 016
FAX: (1) 414 382-4444

**EUROPE/MIDDLE
EAST/AFRICA
HEADQUARTERS**
Allen-Bradley Europe B.V.
Amsterdamseweg 15
1422 AC Uithoorn
The Netherlands
Tel: (31) 2975/43500
Telex: (844) 18042
FAX: (31) 2975/60222

**ASIA/PACIFIC
HEADQUARTERS**
Allen-Bradley (Hong Kong)
Limited
Room 1006, Block B, Sea
View Estate
28 Watson Road
Hong Kong
Tel: (852) 887-4788
Telex: (780) 64347
FAX: (852) 510-9436

**CANADA
HEADQUARTERS**
Allen-Bradley Canada
Limited
135 Dundas Street
Cambridge, Ontario N1R
5X1
Canada
Tel: (1) 519 623-1810
FAX: (1) 519 623-8930

**LATIN AMERICA
HEADQUARTERS**
Allen-Bradley
1201 South Second Street
Milwaukee, WI 53204 USA
Tel: (1) 414 382-2000
Telex: 43 11 016
FAX: (1) 414 382-2400