



Selectable Contact Output Module (Catalog Number 1771-OWN)

Contents

Use this document as a guide when installing the catalog number 1771-OWN series B contact output module.

To	See page
↓ Important User Information	1
↓ Preinstallation Considerations	4
↓ Power Supply Requirements	4
↓ Key the Backplane Connector	5
↓ Set the Relay Output Jumpers	5
↓ Install the Module and Field Wiring Arm	7
↓ Connect Wiring to the Field Wiring Arm	8

For this reference information	See page
➡ Interpreting the Status Indicators	11
➡ Hazardous Location Approval	12
➡ Specifications	13

Important User Information

Because of the variety of uses for the products described in this publication, those responsible for the application and use of these products must satisfy themselves that all necessary steps have been taken to assure that each application and use meets all performance and safety requirements, including any applicable laws, regulations, codes and standards. In no event will Rockwell Automation be responsible or liable for indirect or consequential damage resulting from the use or application of these products.

Any illustrations, charts, sample programs, and layout examples shown in this publication are intended solely for purposes of example. Since there are many variables and requirements associated with any particular installation, Rockwell Automation does not assume responsibility or liability (to include intellectual property liability) for actual use based upon the examples shown in this publication.

Allen-Bradley publication SGI-1.1, Safety Guidelines for Application, Installation, and Maintenance of Solid-State Control (available from your local Rockwell Automation office), describes some important differences between solid-state equipment and electromechanical devices that should be taken into consideration when applying products such as those described in this publication.

Reproduction of the contents of this copyrighted publication, in whole or part, without written permission of Rockwell Automation, is prohibited.

Throughout this publication, notes may be used to make you aware of safety considerations. The following annotations and their accompanying statements help you to identify a potential hazard, avoid a potential hazard, and recognize the consequences of a potential hazard.

WARNING

Identifies information about practices or circumstances that can cause an explosion in a hazardous environment, which may lead to personal injury or death, property damage, or economic loss.

ATTENTION

Identifies information about practices or circumstances that may lead to personal injury or death, property damage, or economic loss.

IMPORTANT

Identifies information that is critical for successful application and understanding of the product.

ATTENTION**Environment and Enclosure**

This equipment is intended for use in a Pollution Degree 2 industrial environment, in overvoltage Category II applications (as defined in IEC publication 60664-1), at altitudes up to 2000 meters without derating.

This equipment is considered Group 1, Class A industrial equipment according to IEC/CISPR Publication 11. Without appropriate precautions, there may be potential difficulties ensuring electromagnetic compatibility in other environments due to conducted as well as radiated disturbance.

This equipment is supplied as “open type” equipment. It must be mounted within an enclosure that is suitably designed for those specific environmental conditions that will be present, and appropriately designed to prevent personal injury resulting from accessibility to live parts. The interior of the enclosure must be accessible only by the use of a tool. Subsequent sections of this publication may contain additional information regarding specific enclosure type ratings that are required to comply with certain product safety certifications.

See NEMA Standards publication 250 and IEC publication 60529, as applicable, for explanations of the degrees of protection provided by different types of enclosures. Also, see the appropriate sections in this publication, as well as the Allen-Bradley publication 1770-4.1, (“Industrial Automation Wiring and Grounding Guidelines”), for additional installation requirements pertaining to this equipment.

ATTENTION**Preventing Electrostatic Discharge**

This equipment is sensitive to electrostatic discharge, which can cause internal damage and affect normal operation. Follow these guidelines when you handle this equipment:

- Touch a grounded object to discharge potential static.
 - Wear an approved grounding wriststrap.
 - Do not touch connectors or pins on component boards.
 - Do not touch circuit components inside the equipment.
 - If available, use a static-safe workstation.
 - When not in use, keep modules in appropriate static-safe packaging.
-

Pre-installation Considerations

This module must be used in a 1771-A1B through -A4B or later I/O chassis. This module does not contain surge limiting circuitry. **Use this module for switching resistive loads only. It is not recommended for inductive or capacitive loads.**

The outputs are arranged in 4 groups of 8, each group with its own common. The module can simultaneously switch all 32 outputs to separate loads, with a maximum of 12A per module. Each output can conduct a maximum load of 1.0A continuously at 30W at 45°C, and 15W at 60°C maximum. Ac loads switched by the modules should have a power factor (PF) of 1.0.

Maximum interconnect cable length for this module is 1000 ft. (304.8 meters).

Power Supply Requirements

The controller or I/O chassis power supply, connected through the backplane of the I/O chassis, powers the logic circuitry of the contact output modules. This supply also provides the necessary power to energize the coils of the module relays. The maximum current drawn from this supply when all coils are energized is 2.5A. Nominal backplane current is 1.8A.

Key the Backplane Connector

Place your module in any slot in the chassis except the leftmost slot which is reserved for processors or adapters.

ATTENTION



Observe the following precautions when inserting or removing keys:

- insert or remove keys with your fingers
- make sure that key placement is correct

Incorrect keying or the use of a tool can result in damage to the backplane connector and possible system faults.

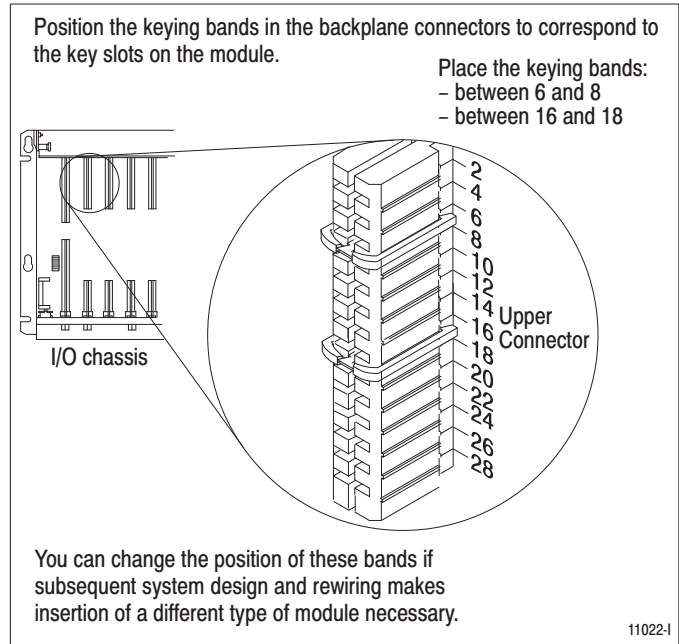

Setting the Relay Output Jumpers

When the output image table bit at the address corresponding to any output is energized (set to 1), the corresponding relay contact is closed or opened, respective to the jumper setting.

All outputs are individually selectable for either normally-open or normally-closed operation. They are pre-set for normally-open operation at the factory. To reset any jumper, proceed as follows:

1. Remove the 4 screws from the side cover and separate the circuit board from the 2 covers.
2. Move the jumper to the desired position. Jumpers are identified by jumper number and use (N.O. or N.C.). Refer to Table A for jumper and terminal identifications.

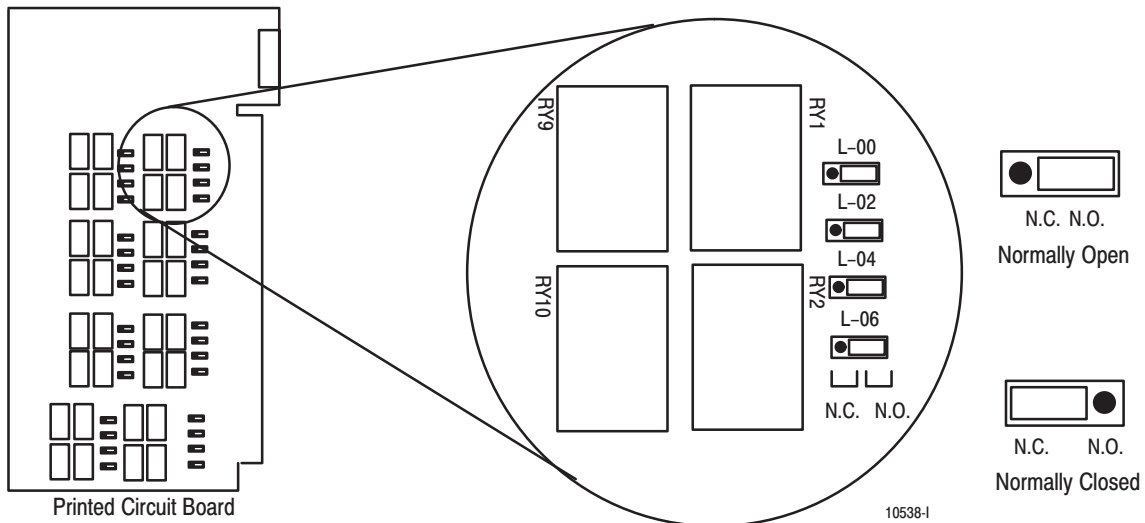

3. Reinstall the circuit board in the module and replace the cover.

Table A
Jumper Identification for Individual Outputs

Terminal Number	Function	Jumper Number	Terminal Number	Function	Jumper Number
1	Common 0		21	Common 2	
2	Output 00	L-00	22	Output 00	H-00
3	Output 01	L-01	23	Output 01	H-01
4	Output 02	L-02	24	Output 02	H-02
5	Output 03	L-03	25	Output 03	H-03
6	Output 04	L-04	26	Output 04	H-04
7	Output 05	L-05	27	Output 05	H-05
8	Output 06	L-06	28	Output 06	H-06
9	Output 07	L-07	29	Output 07	H-07
10	Not used		30	Not used	
11	Common 1		31	Common 3	
12	Output 10	L-10	32	Output 10	H-10
13	Output 11	L-11	33	Output 11	H-11
14	Output 12	L-12	34	Output 12	H-12
15	Output 13	L-13	35	Output 13	H-13
16	Output 14	L-14	36	Output 14	H-14
17	Output 15	L-15	37	Output 15	H-15
18	Output 16	L-16	38	Output 16	H-16
19	Output 17	L-17	39	Output 17	H-17
20	Not used		40	Not used	

If using multiple power supplies, do not exceed the specified isolation voltage.

Install the Module and Field Wiring Arm

ATTENTION



Remove power from the 1771 I/O chassis backplane before you install the module. Failure to remove power from the backplane could cause:

- module damage
- degradation of performance
- injury or equipment damage due to possible unexpected operation

WARNING



When you insert or remove the module with field power applied, or connect or disconnect the field wiring arm with field side power applied, an electrical arc can occur. This could cause an explosion in hazardous location installations. Be sure that power is removed or the area is nonhazardous before proceeding.

1

Place the module in the card guides on the top and bottom of the chassis that guide the module into position.

Important: Apply firm even pressure on the module to seat it into its backplane connector.

1771-A1B, -A2B, -A3B, -A4B I/O chassis

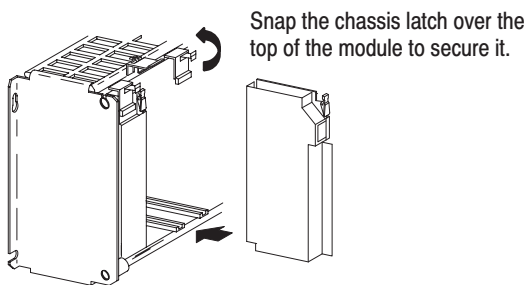

1771-A1B, -A2B, -A4B Series B I/O chassis

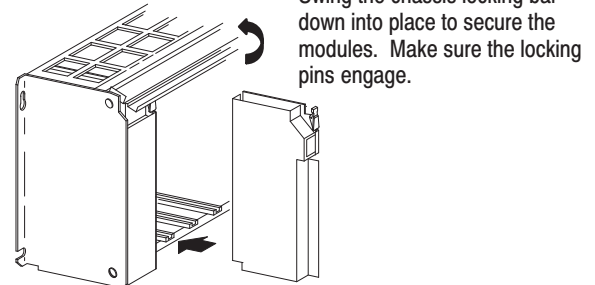

2

Attach the wiring arm (1771-WN) to the horizontal bar at the bottom of the I/O chassis.

The wiring arm pivots upward and connects with the module so you can install or remove the module without disconnecting the wires.

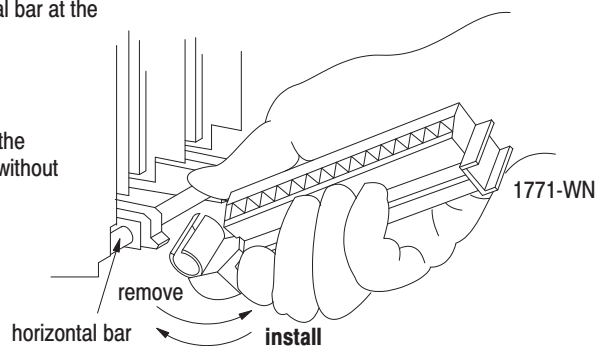

The 1771-OWN module is a modular component of the 1771 I/O system requiring a properly installed system chassis. Refer to publication 1771-IN075 for detailed information on acceptable chassis, proper installation and grounding requirements. Limit the maximum adjacent slot power dissipation to 10W maximum.

Connect Wiring to the Module

Make wiring connections to the module through the field wiring arm (cat. no. 1771-WN). The arm pivots on the I/O chassis to connect with terminals on the front of the module and acts as a terminal strip. The wiring arm allows the module to be removed from the chassis without disconnecting wiring.

WARNING

When you connect or disconnect the field wiring arm with field power applied, or remove the module while backplane power is on, an electrical arc can occur. This could cause an explosion in hazardous location installations.

Be sure that power is removed or the area is nonhazardous before proceeding.

ATTENTION

Remove power from the 1771 I/O chassis backplane and field wiring arm before removing or installing an I/O module.

- Failure to remove power from the backplane or wiring arm could cause module damage, degradation of performance, or injury.
- Failure to remove power from the backplane could cause injury or equipment damage due to possible unexpected operation.

-
1. Make certain all power is removed from the module before making wiring connections.
 2. Swing the wiring arm up into position on the front of the module. The locking tab on the module will secure it into place.

3. Make your connections to the field wiring arm as shown in the connection diagram. (Use the label on the front of the wiring arm to identify your wiring.)

IMPORTANT

The field wiring arm terminal identification number is not the same as the number of the bit which controls that output.

Connection Diagram for the 1771-OWN DC Output Module

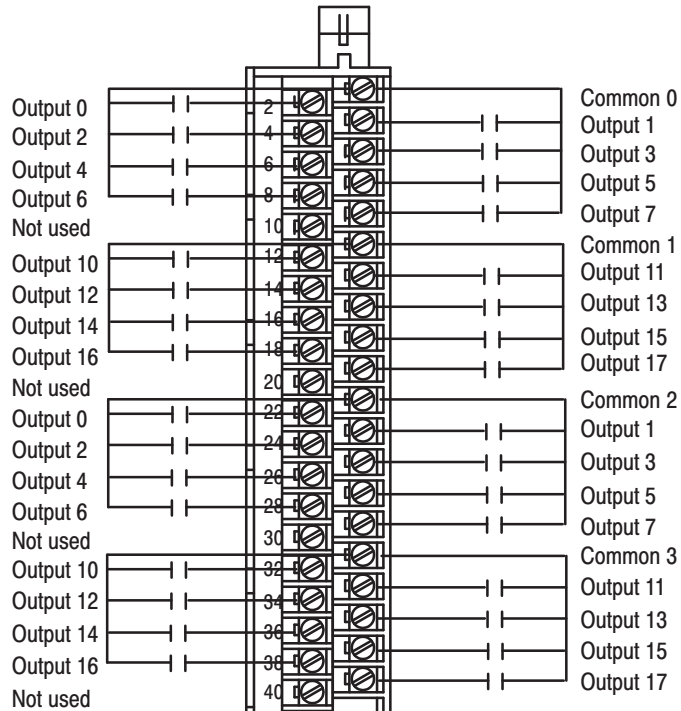

Note: Terminals on the left are even numbered, and terminals on the right are odd numbered.

Note: Contacts shown in N.O. configuration for simplicity.

(Actual wiring runs in this direction.)

10539-1

If multiple power supplies are used, do not exceed the specified isolation voltage.

ATTENTION

Miswiring or shorting the output terminals will cause permanent damage to this module.



ATTENTION

Observe proper polarity with dc power connections. Reverse polarity, or application of ac voltage could damage the module.



ATTENTION



Do not attempt to increase load current or wattage capability beyond the rating by connecting two or more outputs in parallel. The slightest variation in output relay switching time may cause one set of contacts to switch the total load current.

You can use the 1771-OWN output module to drive an input of a 120V ac input module (1771-IA, -IA2, -IAD) to indicate status of turning on a motor starter as shown below, for example, but you must connect a 15K, 2W resistor between the output and L2 (common). Inputs configured with the output module are not isolated from each other.

Driving an Input Module with a 1771-OWN Output Module

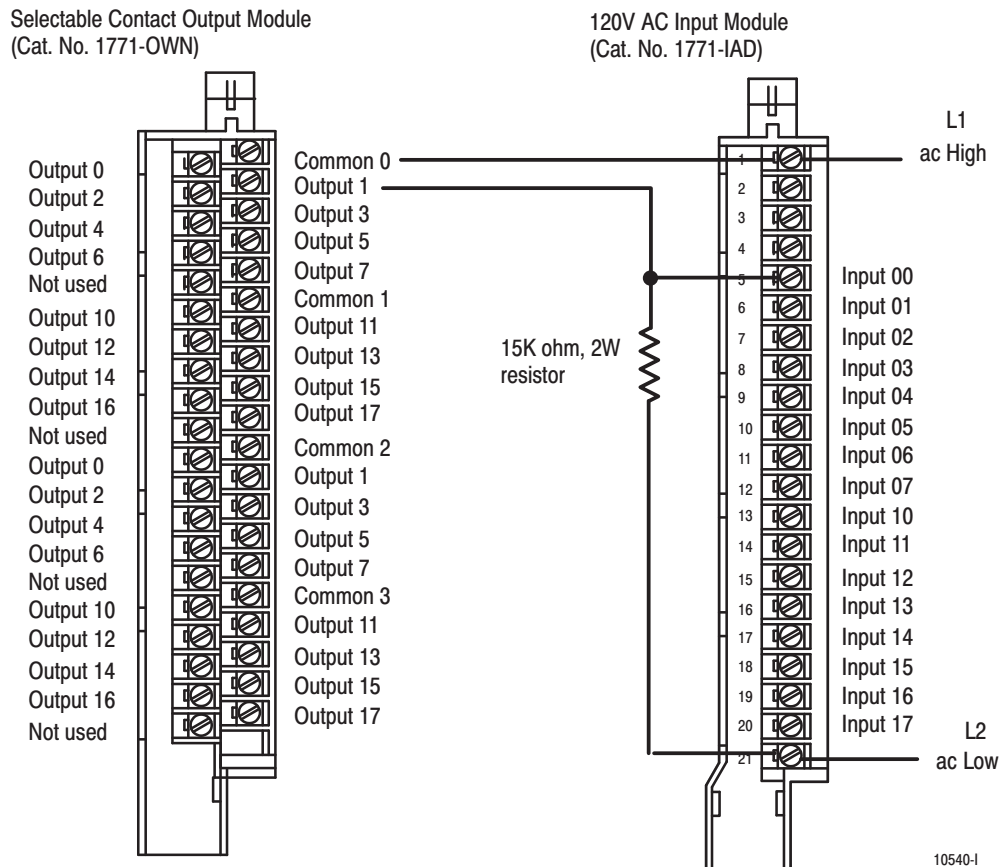

If multiple power supplies are used, do not exceed the specified isolation voltage.

Interpreting the Status Indicators

The module has 32 status indicators on the module front plate. These represent the control status of the outputs. Each indicator is lit when its corresponding output is energized. An additional indicator is provided to indicate a blown fuse condition.

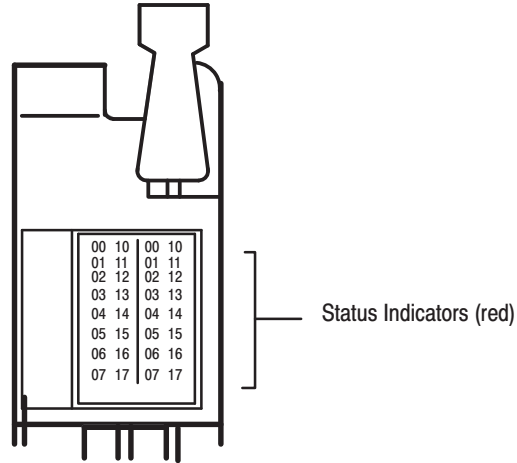

10541-I

The following information applies when operating this equipment in hazardous locations:

Products marked “CL I, DIV 2, GP A, B, C, D” are suitable for use in Class I Division 2 Groups A, B, C, and D Hazardous Locations and nonhazardous locations only. Each product is supplied with markings on the rating nameplate indicating the hazardous location temperature code. When combining products within a system, the most adverse temperature code (lowest “T” number) may be used to help determine the overall temperature code of the system. Combinations of equipment in your system are subject to investigation by the local Authority Having Jurisdiction at the time of installation.

WARNING



EXPLOSION HAZARD –

- Do not disconnect equipment unless power has been removed or the area is known to be nonhazardous.
 - Do not disconnect connections to this equipment unless power has been removed or the area is known to be nonhazardous. Secure any external connections that mate to this equipment by using screws, sliding latches, threaded connectors, or other means provided with this product.
 - Substitution of components may impair suitability for Class I, Division 2.
 - If this product contains batteries, they must only be changed in an area known to be nonhazardous.
-

Informations sur l'utilisation de cet équipement en environnements dangereux:

Les produits marqués CL I, DIV 2, GP A, B, C, D ne conviennent que une utilisation en environnements de Classe I Division 2 Groupes A, B, C, D dangereux et non dangereux. Chaque produit est livré avec des marquages sur sa plaque d'identification qui indiquent le code de température pour les environnements dangereux. Lorsque plusieurs produits sont combinés dans un système, le code de température le plus défavorable (code de température le plus faible) peut être utilisé pour déterminer le code de température global du système. Les combinaisons d'équipements dans le système sont sujettes à inspection par les autorités locales qualifiées au moment de l'installation.

AVERTISSEMENT



RISQUE D'EXPLOSION –

- Couper le courant ou s'assurer que l'environnement est classé non dangereux avant de débrancher l'équipement.
 - Couper le courant ou s'assurer que l'environnement est classé non dangereux avant de débrancher les connecteurs. Fixer tous les connecteurs externes reliés à cet équipement à l'aide de vis, loquets coulissants, connecteurs filetés ou autres moyens fournis avec ce produit.
 - La substitution de composants peut rendre cet équipement inadapté à une utilisation en environnement de Classe 1, Division 2.
 - S'assurer que l'environnement est classé non dangereux avant de changer les piles.
-

Specifications

Outputs per module	32 (4 groups of 8)
Module Location	1771-A1B thru -A4B or later I/O Chassis, 1771-AM, -AM1 I/O Chassis
Voltage Rating	24 - 138V ac rms; 24 - 125V dc
Current Rating ¹	1A continuous (derate linearly 0.033A/°C above 45°C) 12A (derate linearly 0.4A/°C above 45°C) 4A (derate linearly 0.133A/°C above 45°C)
Max. per channel	
Max. per module	
Max. per group	
Maximum Surge Current	1A (max) per output (at rated power) ²
Output Contact Power Rating	30W per output (resistive) at 45°C, 15W at 60°C
Minimum Contact Load	10mA
Operate/Release Time	5ms (+1ms) typical
Bounce Time	1ms (max)
Switching Frequency	10Hz (max)
Power Dissipation	All relays off: 15mW; All relays on: 13.7W (max.)
Thermal Dissipation	All relays off: 0.05 BTU/hr; All relays on: 46.7 BTU/hr (max.)
Backplane Current	2.5A maximum; 1.8A nominal
Isolation Voltage	Tested to withstand 1000V for 60s.
Interconnect Cable Length	1000 ft. (304.8 meters)
Conductors	14–22 AWG (2.5–0.5mm ²) (max) stranded copper rated at 60°C or greater
Wire Size	3/64 inch (1.2mm) insulation (max)
Category	2 ³
Environmental Conditions	
Operating Temperature	IEC 60068–2–1 (Test Ad, Operating Cold) IEC 60068–2–2 (Test Bd, Operating Dry Heat) IEC 60068–2–14 (Test Nb, Operating Thermal Shock) 32 to 140°F (0° to 60°C)
Storage Temperature	IEC 60068–2–1 (Test Ab, Unpackaged, Nonoperating Cold) IEC 60068–2–2 (Test Bb, Unpackaged, Nonoperating Dry Heat) IEC 60068–2–14 (Test Na, Unpackaged, Nonoperating Thermal Shock) –40 to 185°F (–40 to 85°C)
Relative Humidity	IEC 60068–2–30 (Test Db, Unpackaged, Nonoperating Damp Heat) 5 to 95%, noncondensing
Shock	IEC 60068–2–27 (Test Ea, Unpackaged Shock)
Operating	30g
Nonoperating	50g
Vibration	IEC 60068–2–6 (Test Fc, Operating) 2g @ 10–500Hz
ESD Immunity	IEC 61000–4–2 4kV contact discharges
Radiated RF Immunity	IEC 61000–4–3 10V/m with 1kHz sine-wave 80% AM from 30MHz to 1000MHz 10V/m with 200Hz 50% pulse 100% AM at 900MHz
EFT/B Immunity	IEC 61000–4–4 +1kV @ 5kHz on signal ports –
Surge Transient Immunity	IEC 61000–4–5 +1kV line–line (DM) and +2kV line–earth (CM) on signal ports –

Specifications continued on next page.

Conducted RF Immunity	IEC 61000-4-6 10V rms with 1kHz sine wave 80% AM from 150kHz to 30MHz
Emissions	CISPR 11 Group 1, Class A (with appropriate enclosure)
Enclosure Type Rating	None (open-style)
Keying	Between 6 and 8 Between 16 and 18
Field Wiring Arm	1771-WN
Wiring Arm Screw Torque	9 pound-inches (1.0Nm)
Certifications (when product is marked)	<ul style="list-style-type: none"> UL UL Listed Industrial Control Equipment CSA CSA Certified Process Control Equipment CSA CSA Certified Process Control Equipment for Class I, Division 2 Group A, B, C, D Hazardous Locations CE⁴ European Union 89/336/EEC EMC Directive, compliant with: <ul style="list-style-type: none"> EN 61000-6-4, Industrial Emissions EN 50082-2, Industrial Immunity EN 61326, Meas./Control/Lab., Industrial Requirements EN 61000-6-2, Industrial Immunity European Union 73/23/EEC LVD Directive, compliant with: <ul style="list-style-type: none"> EN 61131-2, Programmable Controllers C-Tick⁴ Australian Radiocommunications Act, compliant with: <ul style="list-style-type: none"> AS/NZS 2064, Industrial Emissions

¹ Spikes, peaks and surges must be within the power rating. Resistive loads only. ac and dc power = 30W max.

² Surge limiting circuitry is not provided in the module. For reliable operation, the user must ensure that surges do not exceed either the voltage or current rating of the module.

³ You use this conductor category information for planning conductor routing as described in publication 1770-4.1, Industrial Automation Wiring and Grounding Guidelines.

⁴ See the Product Certification link at www.ab.com for Declarations of Conformity, Certificates and other certification details

www.rockwellautomation.com

Power, Control and Information Solutions Headquarters

Americas: Rockwell Automation, 1201 South Second Street, Milwaukee, WI 53204-2496 USA, Tel: (1) 414.382.2000, Fax: (1) 414.382.4444

Europe/Middle East/Africa: Rockwell Automation, Vorstlaan/Boulevard du Souverain 36, 1170 Brussels, Belgium, Tel: (32) 2 663 0600, Fax: (32) 2 663 0640

Asia Pacific: Rockwell Automation, Level 14, Core F, Cyberport 3, 100 Cyberport Road, Hong Kong, Tel: (852) 2887 4788, Fax: (852) 2508 1846