

Compact High-density Analog Voltage Input Module

Catalog Number 1769-IF16V

Topic	Page
Important User Information	2
Electrostatic Discharge	3
Remove Power	3
Hazardous Location	4
Environnements dangereux	4
About the 1769-IF16V Module	5
Install the 1769-IF16V Module	6
Adding the Module to the 1769 System	6
Mounting Expansion I/O	9
Making Field Wiring Connections	11
Configure the 1769-IF16V Module	15
Specifications	23
Replacement Parts	25
Additional Resources	26

Important User Information

Solid state equipment has operational characteristics differing from those of electromechanical equipment. Safety Guidelines for the Application, Installation and Maintenance of Solid State Controls (Publication SGI-1.1 available from your local Rockwell Automation sales office or online at <http://literature.rockwellautomation.com>) describes some important differences between solid state equipment and hard-wired electromechanical devices. Because of this difference, and also because of the wide variety of uses for solid state equipment, all persons responsible for applying this equipment must satisfy themselves that each intended application of this equipment is acceptable.





In no event will Rockwell Automation, Inc. be responsible or liable for indirect or consequential damages resulting from the use or application of this equipment.

The examples and diagrams in this manual are included solely for illustrative purposes. Because of the many variables and requirements associated with any particular installation, Rockwell Automation, Inc. cannot assume responsibility or liability for actual use based on the examples and diagrams.

No patent liability is assumed by Rockwell Automation, Inc. with respect to use of information, circuits, equipment, or software described in this manual.

Reproduction of the contents of this manual, in whole or in part, without written permission of Rockwell Automation, Inc., is prohibited.

Throughout this manual, when necessary, we use notes to make you aware of safety considerations.

<p>WARNING</p> 	<p>Identifies information about practices or circumstances that can cause an explosion in a hazardous environment, which may lead to personal injury or death, property damage, or economic loss.</p>
<p>IMPORTANT</p>	<p>Identifies information that is critical for successful application and understanding of the product.</p>
<p>ATTENTION</p> 	<p>Identifies information about practices or circumstances that can lead to personal injury or death, property damage, or economic loss. Attentions help you identify a hazard, avoid a hazard and recognize the consequences.</p>
<p>SHOCK HAZARD</p> 	<p>Labels may be on or inside the equipment (for example, a drive or motor) to alert people that dangerous voltage may be present.</p>
<p>BURN HAZARD</p> 	<p>Labels may be on or inside the equipment (for example, a drive or motor) to alert people that surfaces may reach dangerous temperatures.</p>

Electrostatic Discharge

ATTENTION

Electrostatic discharge can damage integrated circuits or semiconductors if you touch bus connector pins. Follow these guidelines when you handle the module:

- Touch a grounded object to discharge static potential.
 - Wear an approved wrist-strap grounding device.
 - Do not touch the bus connector or connector pins.
 - Do not touch circuit components inside the module.
 - Use a static-safe work station, if available.
 - Keep the module in its static-shield box when not in use.
-

Remove Power

ATTENTION

Remove power before removing or inserting this module. When you remove or insert a module with power applied, an electrical arc may occur. An electrical arc can cause personal injury or property damage by:

- sending an erroneous signal to your system's field devices, causing unintended machine motion.
- causing an explosion in a hazardous environment.

Electrical arcing causes excessive wear to contacts on both the module and its mating connector. Worn contacts may create electrical resistance.

Hazardous Location

This equipment is suitable for use in Class I, Division 2, Groups A, B, C, D or non-hazardous locations only. The following statement applies to use in hazardous locations.

WARNING



EXPLOSION HAZARD

Substitution of components may impair suitability for Class I, Division 2.

Do not replace components or disconnect equipment unless power is switched off or the area is known to be non-hazardous.

Do not connect or disconnect components unless power is switched off or the area is known to be non-hazardous.

This product must be installed in an enclosure.

All wiring must comply with Class I, Division 2 wiring methods of Article 501 of the National Electrical Code and/or in accordance with Section 18-1J2 of the Canadian Electrical Code, and in accordance with the authority having jurisdiction.

Environnements dangereux

Cet équipement est conçu pour être utilisé dans des environnements de Classe 1, Division 2, Groupes A, B, C, D ou non dangereux. La mise en garde suivante s'applique à une utilisation dans des environnements dangereux.

ATTENTION



DANGER D'EXPLOSION

La substitution de composants peut rendre cet équipement impropre à une utilisation en environnement de Classe 1, Division 2.

Ne pas remplacer de composants ou déconnecter l'équipement sans s'être assuré que l'alimentation est coupée et que l'environnement est classé non dangereux.

Ne pas connecter ou déconnecter des composants sans s'être assuré que l'alimentation est coupée ou que l'environnement est classé non dangereux.

Ce produit doit être installé dans une armoire.

About the 1769-IF16V Module

Compact I/O is suitable for use in an industrial environment when installed in accordance with these instructions. Specifically, this equipment is intended for use in clean, dry environments (Pollution degree 2⁽¹⁾) and to circuits not exceeding Over Voltage Category II⁽²⁾ (IEC 60664-1)⁽³⁾.

Module Description

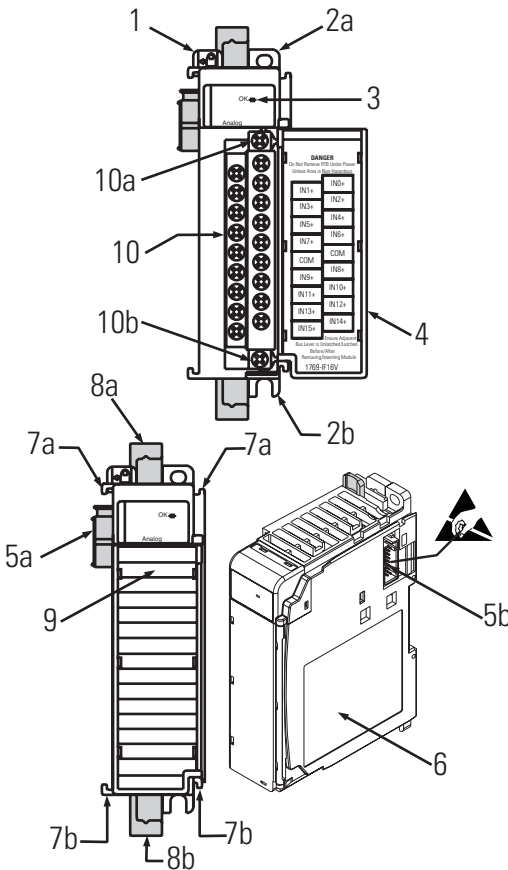

Item	Description
1	Bus lever (with locking function)
2a	Upper panel mounting tab
2b	Lower panel mounting tab
3	Module status indicator
4	Module door with terminal identification label
5a	Movable bus connector with female pins
5b	Stationary bus connector with male pins
6	Nameplate label
7a	Upper tongue-and-groove slots
7b	Lower tongue-and-groove slots
8a	Upper DIN rail latch
8b	Lower DIN rail latch
9	Write-on label (user ID tag)
10	Removable terminal block (RTB) with finger-safe cover
10a	RTB upper retaining screw
10b	RTB lower retaining screw

- (1) Pollution Degree 2 is an environment where, normally, only non-conductive pollution occurs except that occasionally a temporary conductivity caused by condensation is expected.
- (2) Over Voltage Category II is the load level section of the electrical distribution system. At this level, transient voltages are controlled and do not exceed the impulse voltage capability of the product's insulation.
- (3) Pollution Degree 2 and Over Voltage Category II are International Electrotechnical Commission (IEC) designations.

Simplified Input Circuit Diagram

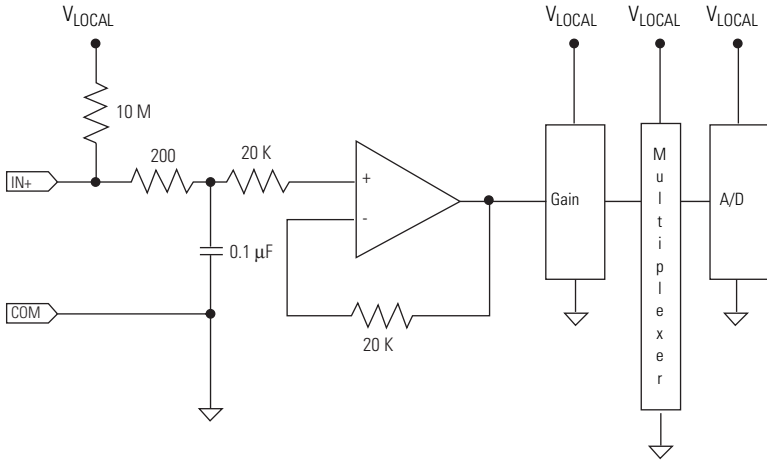

Install the 1769-IF16V Module

Follow these steps to install the module.

1. Add the module to the 1769 system.
You can add the module before or after mounting.
2. Mount Expansion I/O.
 - Panel mount
 - DIN-rail mount
3. Make field wiring connections.
4. Configure the module.

This publication describes these steps in detail.

Adding the Module to the 1769 System

Attach the module to the controller or an adjacent I/O module before or after mounting. For mounting instructions, see [Use the Dimensional Template](#), or [Mount the Module to a DIN Rail](#). To work with a system that is already mounted, see [Replace a Single Module Within a System](#).

Assemble the 1769 System

The following procedure shows you how to assemble the Compact I/O system.

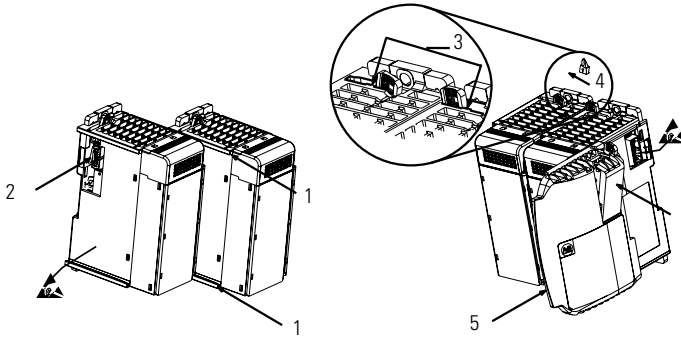

1. Disconnect power.
2. Check that the bus lever of the module to be installed is in the unlocked (fully right) position.
3. Use the upper and lower tongue-and-groove slots (1) to secure the modules together or to a controller.
4. Move the module back along the tongue-and-groove slots until the bus connectors (2) line up with each other.
5. Push the bus lever back slightly to clear the positioning tab (3).
Use your fingers or a small screwdriver.
6. To allow communication between the controller and module, move the bus lever fully to the left (4) until it clicks, making sure it is locked firmly in place.

ATTENTION



When attaching I/O modules, it is very important that the bus connectors are securely locked together to be sure of proper electrical connection. Securely locking together the bus connectors is required for use in hazardous locations.

For more information on hazardous locations see [page 4](#).

7. Attach an end-cap terminator (5) to the last module in the system by using the tongue-and-groove slots as before.

8. Lock the end-cap bus terminator (6).

IMPORTANT

You must use a 1769-ECR or 1769-ECL right or left end cap to terminate the end of the serial communication bus. An I/O configuration fault will occur if an end cap is not used.

Replace a Single Module Within a System

The module can be replaced while the system is mounted to a panel or DIN rail.

1. Remove power.
See [Remove Power on page 3](#).
2. Remove the upper and lower mounting screws from the module or open the DIN latches using a flat-blade or Phillips screwdriver.
3. Move the bus lever to the right to disconnect or unlock the bus.
4. On the right-side adjacent module, move its bus lever to the right (unlock) to disconnect it from the module to be removed.
5. Gently slide the disconnected module forward.

If you feel excessive resistance, check that the module is disconnected from the bus and that both mounting screws are removed or DIN latches opened.

TIP

It may be necessary to rock the module slightly from front to back to remove it, or, in a panel-mounted system, to loosen the screws of adjacent modules.

6. Be sure that the bus lever on the module and on the right-side adjacent module are in the unlocked (fully right) position before installing the replacement module.
7. Slide the replacement module into the open slot.
8. Connect the modules by locking (fully left) the bus levers on the replacement module and the right-side adjacent module.
9. Replace the mounting screws or snap the module onto the DIN rail.

Mounting Expansion I/O

ATTENTION



During panel or DIN rail mounting of all devices, be sure that all debris, that is, metal chips or wire strands, is kept from falling into the module. Debris that falls into the module could cause damage when cycling power.

Minimum Spacing

Maintain spacing from enclosure walls, wireways, or adjacent equipment. Allow 50 mm (2 in.) of space on all sides for adequate ventilation, as shown.

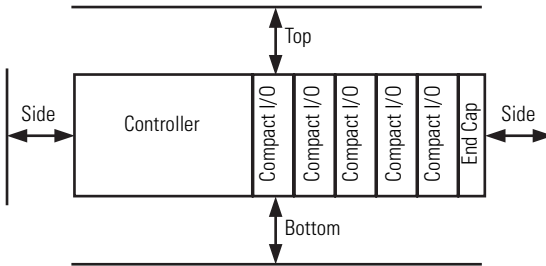

Mount the Module to a Panel

Mount the module to a panel using two screws per module. Use M4 or #8 panhead screws. Mounting screws are required on every module.

Use the Dimensional Template

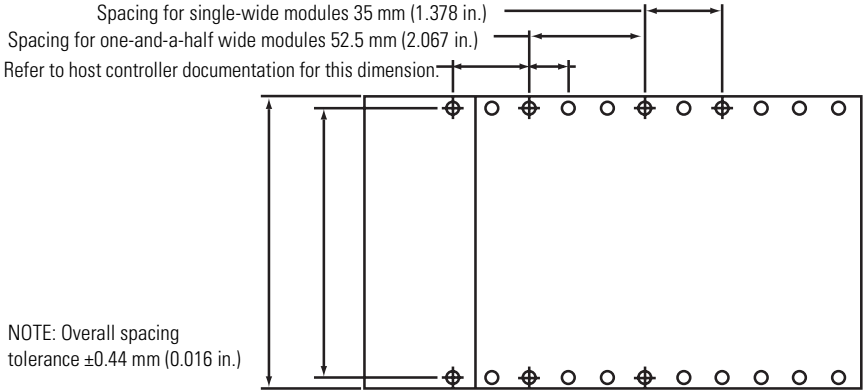

Locate holes every 17.5 mm (0.689 in.) to allow for a mix of single-wide and one-and-a-half-wide modules (for example, the 1769-OA16 module).

Use Modules as a Template

This procedure lets you use the assembled modules as a template for drilling holes in the panel. See [Use the Dimensional Template](#) if you have sophisticated panel mounting equipment.

On a clean work surface, assemble no more than three modules.

Due to module-mounting hole tolerance, it is important to follow this procedure.

1. Using the assembled modules as a template, carefully mark the center of all module-mounting holes on the panel.
2. Return the assembled modules to the clean work surface, including any previously mounted modules.
3. Drill and tap the mounting holes for the recommended M4 or #8 screws.
4. Place the modules back on the panel, and check for proper hole alignment.
5. Attach the modules to the panel using the mounting screws.

TIP

If you are mounting more modules, mount only the last one of this group and put the others aside. This reduces the remounting time during drilling and tapping of the next group.

6. Repeat steps 1...6 for any remaining modules.

Mount the Module to a DIN Rail

The module can be mounted using these DIN rails:

- 35 x 7.5 mm (EN 50 022 - 35 x 7.5)
- 35 x 15 mm (EN 50 022 - 35 x 15)

To mount the module on a DIN rail, follow these steps.

1. Close the DIN rail latches.
2. Press the DIN rail mounting area of the module against the DIN rail.
The latches will momentarily open and lock into place.

Making Field Wiring Connections

Use the information in this section includes to wire the module.

- Grounding the module
- System wiring guidelines
- Input sensors/transmitters wiring
- Terminal labels
- Finger-safe terminal block wiring and removal
- Wire size and terminal screw torque

Grounding the Module

This product is intended to be mounted to a well-grounded mounting surface such as a metal panel. Additional grounding connections from the module's mounting tabs or DIN rail, if used, are not required unless the mounting surface cannot be grounded. Refer to Industrial Automation Wiring and Grounding Guidelines, publication [1770-4.1](#), for additional information.

System Wiring Guidelines

Consider the following when wiring your system:

- All module commons (COM) are connected in the analog module.
- The analog common (COM) is not connected to earth ground inside the module.
- Channels are not isolated from each other.
- Use Belden 8761, or equivalent, shielded wire.
- Under normal conditions, the drain wire and shield junction must be connected to earth ground via a panel or DIN rail mounting screw at the analog I/O module end. Keep the shield connection to ground as short as possible.⁽¹⁾
- To ensure optimum accuracy, limit overall cable impedance by keeping your cable as short as possible. Locate the I/O system as close to your sensors or actuators as your application will permit.⁽²⁾
- If multiple power supplies are used with analog inputs, the power supply commons must be connected.
- The 1769-IF16V module does not provide loop power for analog inputs. Use a Class 2-rated power supply that matches the input transmitter specifications.
- Voltages on the IN+ terminals of the 1769-IF16V module must be within $\pm 10\text{V DC}$ of analog common.

ATTENTION



Be careful when stripping wires. Wire fragments that fall into a module could cause damage at power up. Once wiring is complete, ensure the module is free of all metal fragments.

(1) In environments where high-frequency noise may be present, it may be necessary to directly ground cable shields to earth at the module end and via a 0.1 μF capacitor at the sensor end.

(2) Cable length over 50 m (164 ft) may impact accuracy. For details, refer to the Compact High-Density Analog Input Modules User Manual, publication [1769-UM018](#).

Wire Input Sensors/Transmitters

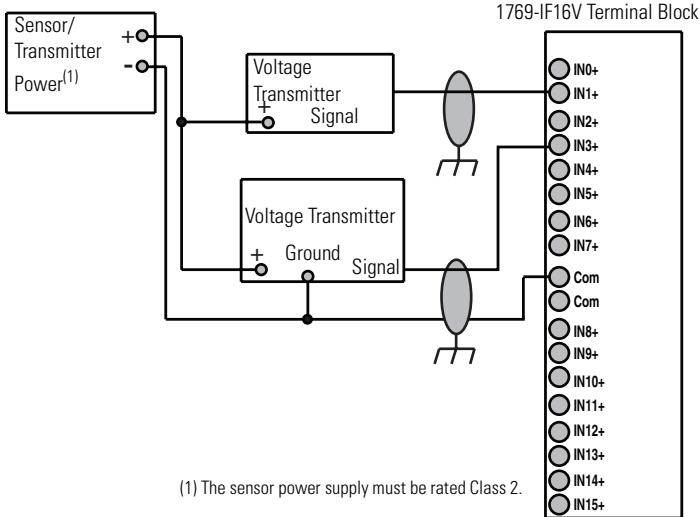

Label the Terminals

A removable, write-on label is provided with the module. Remove the label from the door, mark the identification of each terminal with permanent ink, and slide the label back into the door. Your markings (ID tag) will be visible when the module door is closed.

Remove the Finger-safe Terminal Block

When wiring field devices to the module, it is not necessary to remove the terminal block. If you remove the terminal block, use the write-on label on the side of the terminal block to identify the module slot location and type.



To remove the terminal block, loosen the upper and lower retaining screws. The terminal block will back away from the module as you remove the screws. When replacing the terminal block, torque the retaining screws to 0.46 N•m (4.1 in•lbs).

Wire the Finger-safe Terminal Block

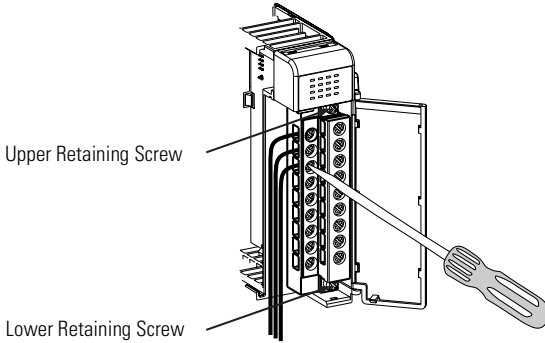

When wiring the terminal block, keep the finger-safe cover in place.

1. Loosen the terminal screws to be wired.
2. Route the wire under the terminal pressure plate.

You can use the bare wire or a spade lug. The terminals will accept a 6.35 mm (0.25 in.) spade lug.

TIP

The terminal screws are non-captive. Therefore, it is possible to use a ring lug [maximum 1/4 inch o.d. with a 0.139 inch minimum i.d. (M3.5)] with the module.

3. Tighten the terminal screw making sure the pressure plate secures the wire.

Recommended torque when tightening terminal screws is 0.68 N•m (6 in•lb).

TIP

If you need to remove the finger-safe cover, insert a screw driver into one of the square wiring holes and gently pry the cover off. If you wire the terminal block with the finger-safe cover removed, you will not be able to put it back on the terminal block because the wires will be in the way.

Wire Size and Terminal Screw Torque

Each terminal accepts two wires with the following restrictions:.

Wire Type		Wire Size	Terminal Screw Torque	Retaining Screw Torque
Solid	Cu-90 °C (194 °F)	#14...#22 AWG	0.68 N•m (6 in•lb)	0.46 N•m (4.1 in•lb)
Stranded	Cu-90 °C (194 °F)	#16...#22 AWG	0.68 N•m (6 in•lb)	0.46 N•m (4.1 in•lb)

Configure the 1769-IF16V Module

Use the following I/O memory mapping tables to configure the 1769-IF16V module.

Output Data File

For each module, slot x , words 0 and 1 in the output data file contain the cancel latched channel alarm control bits.

Word/ Bit	15	14	13	12	11	10	09	08	07	06	05	04	03	02	01	00
Word 0	CL L7	CL H7	CL L6	CL H6	CL L5	CL H5	CL L4	CL H4	CL L3	CL H3	CL L2	CL H2	CL L1	CL H1	CL L0	CL H0
Word 1	CL L15	CL H15	CL L14	CL H14	CL L13	CL H13	CL L12	CL H12	CL L11	CL H11	CL L10	CL H10	CL L9	CL H9	CL L8	CL H8

The bits are defined as follows:

- CLH_x = Cancel High Process Alarm Latch for Input x : Allows each input high-process-alarm latch to be individually cancelled. Cancel = 1.
- CLL_x = Cancel Low Process Alarm Latch for Input x : Allows each input low-process-alarm latch to be individually cancelled. Cancel = 1.

Input Data File

For each module, slot x, words 0...15 in the input data file contain the converted value of the module's analog input channels. Word 16 in the input data file contains the time stamp value (if time stamping is enabled) that corresponds to the module's last input data sampling period. Words 17...21 in the input data file contain status bits for the analog input channels.

Input Data Array

Word/ Bit	15	14	13	12	11	10	09	08	07	06	05	04	03	02	01	00
Word 0	SGN	Analog Read (Input) Data Value Channel 0														
Word 1	SGN	Analog Read (Input) Data Value Channel 1														
Word 2	SGN	Analog Read (Input) Data Value Channel 2														
Word 3	SGN	Analog Read (Input) Data Value Channel 3														
Word 4	SGN	Analog Read (Input) Data Value Channel 4														
Word 5	SGN	Analog Read (Input) Data Value Channel 5														
Word 6	SGN	Analog Read (Input) Data Value Channel 6														
Word 7	SGN	Analog Read (Input) Data Value Channel 7														
Word 8	SGN	Analog Read (Input) Data Value Channel 8														
Word 9	SGN	Analog Read (Input) Data Value Channel 9														
Word 10	SGN	Analog Read (Input) Data Value Channel 10														
Word 11	SGN	Analog Read (Input) Data Value Channel 11														
Word 12	SGN	Analog Read (Input) Data Value Channel 12														
Word 13	SGN	Analog Read (Input) Data Value Channel 13														
Word 14	SGN	Analog Read (Input) Data Value Channel 14														
Word 15	SGN	Analog Read (Input) Data Value Channel 15														
Word 16	Nu	Time Stamp Value														
Word 17	S15	S14	S13	S12	S11	S10	S9	S8	S7	S6	S5	S4	S3	S2	S1	S0
Word 18	L3	H3	U3	O3	L2	H2	U2	O2	L1	H1	U1	O1	L0	H0	U0	O0
Word 19	L7	H7	U7	O7	L6	H6	U6	O6	L5	H5	U5	O5	L4	H4	U4	O4
Word 20	L11	H11	U11	O11	L10	H10	U10	O10	L9	H9	U9	O9	L8	H8	U8	O8
Word 21	L15	H15	U15	O15	L14	H14	U14	O14	L13	H13	U13	O13	L12	H12	U12	O12

The bits are defined as follows:

- SGN = Sign bit in 2's complement format.
- Nu = Not Used. Bit set to 0.
- S_x = General Status bit for input channels 0...15.
- O_x = Over range flag bits for input channels 0...15.
- U_x = Under range flag bits for input channels 0...15.
- H_x = High Alarm flag bits for input channels 0...15.
- L_x = Low Alarm flag bits for input channels 0...15.

Configuration Data File

The manipulation of bits from this file is normally done with programming software (for example, RSLogix 5000, RSLogix 500, or RSNetWorx for DeviceNet software) during initial configuration of the system. In that case, graphical screens provided by the programming software simplify configuration.

Some systems, like the 1769-ADN DeviceNet adapter system, also allow the bits to be altered as part of the control program using communication rungs. In that case, it is necessary to understand the bit arrangement.

Configuration Data Array

Word/Bit	15	14	13	12	11	10	09	08	07	06	05	04	03	02	01	00
Word 0	0	Real Time Sample Value														
Word 1	ETS	Reserved														
Word 2	EC	Reserved				EA	AL	E _I ⁽¹⁾	Reserved				Input Filter Sel Ch0			
Word 3	Reserved				Input Data Format Ch0			Reserved				Input Type/Range Select Ch0				
Word 4	SGN	Process Alarm High Data Value Channel 0														
Word 5	SGN	Process Alarm Low Data Value Channel 0														
Word 6	SGN	Alarm Dead Band Value Channel 0														
Word 7	Reserved															
Word 8	EC	Reserved				EA	AL	E _I ⁽¹⁾	Reserved				Input Filter Sel Ch1			
Word 9	Reserved				Input Data Format Ch1			Reserved				Input Type/Range Select Ch1				
Word 10	SGN	Process Alarm High Data Value Channel 1														
Word 11	SGN	Process Alarm Low Data Value Channel 1														
Word 12	SGN	Alarm Dead Band Value Channel 1														
Word 13	Reserved															

Configuration Data Array

Word/Bit	15	14	13	12	11	10	09	08	07	06	05	04	03	02	01	00
Word 14	EC	Reserved				EA	AL	E _I ⁽¹⁾	Reserved				Input Filter Sel Ch2			
Word 15	Reserved					Input Data Format Ch2			Reserved				Input Type/Range Select Ch2			
Word 16	SGN	Process Alarm High Data Value Channel 2														
Word 17	SGN	Process Alarm Low Data Value Channel 2														
Word 18	SGN	Alarm Dead Band Value Channel 2														
Word 19	Reserved															
Word 20	EC	Reserved				EA	AL	E _I ⁽¹⁾	Reserved				Input Filter Sel Ch3			
Word 21	Reserved					Input Data Format Ch3			Reserved				Input Type/Range Select Ch3			
Word 22	SGN	Process Alarm High Data Value Channel 3														
Word 23	SGN	Process Alarm Low Data Value Channel 3														
Word 24	SGN	Alarm Dead Band Value Channel 3														
Word 25	Reserved															
Word 26	EC	Reserved				EA	AL	E _I ⁽¹⁾	Reserved				Input Filter Sel Ch4			
Word 27	Reserved					Input Data Format Ch4			Reserved				Input Type/Range Select Ch4			
Word 28	SGN	Process Alarm High Data Value Channel 4														
Word 29	SGN	Process Alarm Low Data Value Channel 4														
Word 30	SGN	Alarm Dead Band Value Channel 4														
Word 31	Reserved															
Word 32	EC	Reserved				EA	AL	E _I ⁽¹⁾	Reserved				Input Filter Sel Ch5			
Word 33	Reserved					Input Data Format Ch5			Reserved				Input Type/Range Select Ch5			
Word 34	SGN	Process Alarm High Data Value Channel 5														
Word 35	SGN	Process Alarm Low Data Value Channel 5														
Word 36	SGN	Alarm Dead Band Value Channel 5														
Word 37	Reserved															

Configuration Data Array

Word/Bit	15	14	13	12	11	10	09	08	07	06	05	04	03	02	01	00
Word 38	EC	Reserved				EA	AL	E ⁽¹⁾	Reserved				Input Filter Sel Ch6			
Word 39	Reserved					Input Data Format Ch6			Reserved				Input Type/Range Select Ch6			
Word 40	SGN	Process Alarm High Data Value Channel 6														
Word 41	SGN	Process Alarm Low Data Value Channel 6														
Word 42	SGN	Alarm Dead Band Value Channel 16														
Word 43	Reserved															
Word 44	EC	Reserved				EA	AL	E ⁽¹⁾	Reserved				Input Filter Sel Ch7			
Word 45	Reserved					Input Data Format Ch7			Reserved				Input Type/Range Select Ch7			
Word 46	SGN	Process Alarm High Data Value Channel 7														
Word 47	SGN	Process Alarm Low Data Value Channel 7														
Word 48	SGN	Alarm Dead Band Value Channel 7														
Word 49	Reserved															
Word 50	EC	Reserved				EA	AL	E ⁽¹⁾	Reserved				Input Filter Sel Ch8			
Word 51	Reserved					Input Data Format Ch8			Reserved				Input Type/Range Select Ch8			
Word 52	SGN	Process Alarm High Data Value Channel 8														
Word 53	SGN	Process Alarm Low Data Value Channel 8														
Word 54	SGN	Alarm Dead Band Value Channel 8														
Word 55	Reserved															
Word 56	EC	Reserved				EA	AL	E ⁽¹⁾	Reserved				Input Filter Sel Ch9			
Word 57	Reserved					Input Data Format Ch9			Reserved				Input Type/Range Select Ch9			
Word 58	SGN	Process Alarm High Data Value Channel 9														
Word 59	SGN	Process Alarm Low Data Value Channel 9														
Word 60	SGN	Alarm Dead Band Value Channel 9														
Word 61	Reserved															

Configuration Data Array

Word/Bit	15	14	13	12	11	10	09	08	07	06	05	04	03	02	01	00
Word 62	EC	Reserved				EA	AL	E ⁽¹⁾	Reserved				Input Filter Sel Ch10			
Word 63	Reserved					Input Data Format Ch10			Reserved				Input Type/Range Select Ch10			
Word 64	SGN	Process Alarm High Data Value Channel 10														
Word 65	SGN	Process Alarm Low Data Value Channel 10														
Word 66	SGN	Alarm Dead Band Value Channel 10														
Word 67	Reserved															
Word 68	EC	Reserved				EA	AL	E ⁽¹⁾	Reserved				Input Filter Sel Ch11			
Word 69	Reserved					Input Data Format Ch11			Reserved				Input Type/Range Select Ch11			
Word 70	SGN	Process Alarm High Data Value Channel 11														
Word 71	SGN	Process Alarm Low Data Value Channel 11														
Word 72	SGN	Alarm Dead Band Value Channel 11														
Word 73	Reserved															
Word 74	EC	Reserved				EA	AL	E ⁽¹⁾	Reserved				Input Filter Sel Ch12			
Word 75	Reserved					Input Data Format Ch12			Reserved				Input Type/Range Select Ch12			
Word 76	SGN	Process Alarm High Data Value Channel 12														
Word 77	SGN	Process Alarm Low Data Value Channel 12														
Word 78	SGN	Alarm Dead Band Value Channel 12														
Word 79	Reserved															
Word 80	EC	Reserved				EA	AL	E ⁽¹⁾	Reserved				Input Filter Sel Ch13			
Word 81	Reserved					Input Data Format Ch13			Reserved				Input Type/Range Select Ch13			
Word 82	SGN	Process Alarm High Data Value Channel 13														
Word 83	SGN	Process Alarm Low Data Value Channel 13														
Word 84	SGN	Alarm Dead Band Value Channel 13														
Word 85	Reserved															

Configuration Data Array

Word/Bit	15	14	13	12	11	10	09	08	07	06	05	04	03	02	01	00
Word 86	EC	Reserved				EA	AL	E _I ⁽¹⁾	Reserved				Input Filter Sel Ch14			
Word 87	Reserved					Input Data Format Ch14			Reserved				Input Type/Range Select Ch14			
Word 88	SGN	Process Alarm High Data Value Channel 14														
Word 89	SGN	Process Alarm Low Data Value Channel 14														
Word 90	SGN	Alarm Dead Band Value Channel 14														
Word 91	Reserved															
Word 92	EC	Reserved				EA	AL	E _I ⁽¹⁾	Reserved				Input Filter Sel Ch15			
Word 93	Reserved					Input Data Format Ch15			Reserved				Input Type/Range Select Ch15			
Word 94	SGN	Process Alarm High Data Value Channel 15														
Word 95	SGN	Process Alarm Low Data Value Channel 15														
Word 96	SGN	Alarm Dead Band Value Channel 15														
Word 97	Reserved															

The bits are defined as follows:

- SGN = Sign bit in 2's complement format
- Real Time Sample Value = Provides the ability to configure the Real Time Sample Rate
- ETS = Enable Time Stamping
- EC = Enable Channel
- EA = Enable Alarm
- AL = Alarm Latch
- EI = Enable Input Process Alarm Interrupt⁽¹⁾
- Input Filter Sel Ch_x = Input Channel Filter Setting
- Input Data Format Ch_x = Input Data Format Select
- Input Type/Range Select Ch_x = Input Type/Range Select
- Process Alarm High Data Value Channel _x = Provides the ability to configure the Input Process Alarm High Value
- Process Alarm Low Data Value Channel _x = Provides the ability to configure the Input Process Alarm Low Value
- Alarm Dead Band Value Channel _x = Provides the ability to configure the Dead Band Value

(1) Alarm interrupts are not supported by all bus masters. Check your controller's user manual to determine if expansion I/O interrupts are supported.

Bit Definitions for Channel Configuration Words

Define	To Choose	Make these bit settings															
		15	14	13	12	11	10	09	08	07	06	05	04	03	02	01	00
Input Filter Selection	60 Hz													0	0	0	0
	50 Hz													0	0	0	1
	16 Hz													0	0	1	0
	315 Hz													0	0	1	1
	1365 Hz													0	1	0	0
Enable Interrupt ⁽¹⁾	Enable								1								
	Disable							0									
Process Alarm Latch	Enable							1									
	Disable							0									
Enable Process Alarms	Enable						1										
	Disable						0										
Enable Channel	Enable	1															
	Disable	0															

(1) Alarm interrupts are not supported by all bus masters. Check your controller's user manual to determine if expansion I/O interrupts are supported.

Bit Definitions for Input Range and Input Data Configuration

Define	To Choose	Make these bit settings															
		15	14	13	12	11	10	09	08	07	06	05	04	03	02	01	00
Input Range Select	-10...+10V													0	0	0	0
	0...5V													0	0	0	1
	0...10V													0	0	1	0
	1...5V													0	0	1	1
Input Data Format Select	Proportional Counts						0	0	0								
	Engineering Units						0	0	1								
	Scaled for PID						0	1	0								
	Percent Range						0	1	1								

Specifications

Compact High Density Analog Voltage Input Module - 1769-IF16V

Attribute	Value
Dimensions (HxWxD), approx.	118 mm x 87 mm x 35 mm Height including mounting tabs is 138 mm (5.43 in.) 4.65 in. x 3.43 in. x 1.38 in. Height including mounting tabs is 138 mm (5.43 in.)
Weight, approx. (with carton)	281 g (0.62 lb)
Temperature, storage	-40 °C...85 °C (-40 °F...185 °F)
Temperature, operating	0 °C...60 °C (32 °F...140 °F)
Operating humidity	5%...95% non-condensing
Operating altitude	2000 m (6561 ft)
Vibration	Operating: 10...500 Hz, 5 g, 0.030 in. peak-to-peak
Shock	Operating: 30 g, 11 ms panel-mounted (20 g, 11 ms DIN rail-mounted) Non-Operating: 40 g panel-mounted (30 g DIN rail-mounted)
Bus current draw, max	190 mA @ 5V DC 70 mA @ 24V DC
Heat dissipation	2.4 total Watts (The Watts per point plus the minimum Watts with all points energized.)
Module OK status indicator	On: The module has power, has passed internal diagnostics, and is communicating over the bus. Off: Any of the above is not true.
System power supply distance rating	The module may not be more than 8 modules away from the system power supply.
Recommended cable	Belden 8761 (shielded)
Vendor I.D. code	1
Product type code	10
Product code	46
Input words	22
Output words	2
Configuration words	98

Input Specifications

Attribute	Value
Analog normal operating ranges ⁽¹⁾	±10V DC, 0 ... 10V DC, 0...5V DC, 1...5V DC
Full scale analog ranges ⁽¹⁾	±10.5V DC, -0.5...10.5V DC, -0.5...5.25V DC, 0.5...5.25V DC
Number of inputs	16 single-ended
Converter type	Sigma Delta
Response speed per channel	Input filter and configuration dependent. ⁽⁸⁾
Resolution, max ⁽²⁾	16 bits (unipolar) 15 bits plus sign (bipolar)
Rated working voltage ⁽³⁾	30V AC/30V DC
Common mode voltage range ⁽⁴⁾	±10V DC maximum per channel
Common mode rejection	greater than 60 dB at 50 and 60 Hz with the 16 Hz filter selected, respectively.
Input impedance	Greater than 1 MΩ (typical)
Overall accuracy ⁽⁵⁾	0.35% full scale at 25 °C (77°F) for 16 Hz, 50 Hz, and 60 Hz filters
Accuracy drift with temperature	±0.003% per °C
Calibration	None required
Non-linearity (in percent full scale)	±0.03%
Repeatability ⁽⁶⁾	±0.06% for 16 Hz filter
Module error over full temperature range (0...60 °C [32 °F...140 °F])	1.0% for 16 Hz, 50 Hz, and 60 Hz filters
Channel diagnostics	Over- or under-range by bit reporting, process alarms
Maximum overload at input terminals ⁽⁷⁾	±30V DC continuous, 0.03 mA
Input group to bus isolation	500V AC or 710V DC for 1 minute (qualification test) 30V AC/30V DC working voltage (IEC Class 2 reinforced insulation)

- (1) The over- or under-range flag will come on when the normal operating range (over/under) is exceeded. The module will continue to convert the analog input up to the maximum full scale range. The flag automatically resets when within the normal operating range.
- (2) Resolution is dependent upon your filter selection.
- (3) Rated working voltage is the maximum continuous voltage that can be applied at the input terminal, including the input signal and the value that floats above ground potential (for example, 10V DC input signal and 20V DC potential above ground).
- (4) For proper operation, the plus input terminals must be within ±10V DC of analog common.
- (5) Includes offset, gain, non-linearity and repeatability error terms.
- (6) Repeatability is the ability of the input module to register the same reading in successive measurements for the same input signal.
- (7) Damage may occur to the input circuit if this value is exceeded.
- (8) Refer to the Compact High-Density Analog Input Modules User Manual, publication [1769-UM018](#).

Certifications

Certification	Value
Agency certification	<ul style="list-style-type: none"> • C-UL certified (under CSA C22.2 No. 142) • UL 508 listed • CE compliant for all applicable directives
Hazardous environment class	Class I, Division 2, Hazardous Location, Groups A, B, C, D (UL 1604, C-UL under CSA C22.2 No. 213)
Radiated and conducted emissions	EN50081-2 Class A
Electrical /EMC:	The module has passed testing at the following levels:
<ul style="list-style-type: none"> • ESD Immunity (IEC1000-4-2) • Radiated Immunity (IEC1000-4-3) • Fast Transient Burst (IEC1000-4-4) • Surge Immunity (IEC1000-4-5) • Conducted Immunity (IEC1000-4-6) 	<ul style="list-style-type: none"> • 4 kV contact, 8 kV air, 4 kV indirect • 10 V/m, 80...1000 MHz, 80% amplitude modulation, +900 MHz keyed carrier • 2 kV, 5 kHz • 1 kV galvanic gun • 10V DC, 0.15...80 MHz⁽¹⁾

(1) Conducted Immunity frequency range may be 150 kHz...30 MHz if the Radiated Immunity frequency range is 30 MHz...1000 MHz.

Replacement Parts

The module has the following replacement parts:

- Terminal block, catalog no. 1769-RTBN18 (1 per kit)
- Door, catalog no. 1769-RD (2 per kit)

Additional Resources

For more information refer to the following publications.

Resource	Description
Compact High-Density Analog Input Modules User Manual, publication 1769-UM018 .	Detailed description of how to install , operate, and troubleshoot your Compact I/O module.
1768 CompactLogix Controllers User Manual, publication 1768-UM001	Detailed description of how to install and use your 1768 CompactLogix controller.
MicroLogix 1500 Programmable Controllers User Manual, publication 1764-UM001	Detailed description of how to install and use your Compact I/O with MicroLogix 1500 programmable controllers
MicroLogix 1200 Programmable Controllers User Manual, publication 1762-UM001	Detailed description of how to install and use your Compact I/O with MicroLogix 1500 programmable controllers
1769-ADN DeviceNet Adapter User Manual, publication 1769-UM001	Detailed description of how to install and use your Compact I/O system with the 1769-ADN DeviceNet adapter
CompactLogix System User Manual, publication 1769-UM007	Detailed description of how to install and use your Compact I/O system with the CompactLogix system
Industrial Automation Wiring and Grounding Guidelines, publication 1770-4.1	More information on proper wiring and grounding techniques

You can view or download publications at <http://literature.rockwellautomation.com>. To order paper copies of technical documentation, contact your local Rockwell Automation distributor or sales representative.

Notes:

Allen-Bradley, Rockwell Automation, Compact, CompactLogix, MicroLogix, RSLogix 500, and RSNetWorx for DeviceNet are trademarks of Rockwell Automation, Inc.

Trademarks not belonging to Rockwell Automation are property of their respective companies.

www.rockwellautomation.com

Power, Control and Information Solutions Headquarters

Americas: Rockwell Automation, 1201 South Second Street, Milwaukee, WI 53204-2496 USA, Tel: (1) 414.382.2000, Fax: (1) 414.382.4444

Europe/Middle East/Africa: Rockwell Automation, Vorstlaan/Boulevard du Souverain 36, 1170 Brussels, Belgium, Tel: (32) 2 663 0600, Fax: (32) 2 663 0640

Asia Pacific: Rockwell Automation, Level 14, Core F, Cyberport 3, 100 Cyberport Road, Hong Kong, Tel: (852) 2887 4788, Fax: (852) 2508 1846

Publication 1769-IN086A-EN-P - August 2008

PN-28832

Copyright © 2008 Rockwell Automation, Inc. All rights reserved. Printed in the U.S.A.

