

# Installation Instructions

Original Instructions



**Allen-Bradley**

by ROCKWELL AUTOMATION

## CompactLogix 5370 L1 Controllers

Catalog Numbers 1769-L16ER-BB1B, 1769-L18ER-BB1B, 1769-L18ERM-BB1B, 1769-L19ER-BB1B, 1769-L18ERM-BB1BK, 1769-L19ER-BB1BK

Topic	Page
Summary of Changes	1
Controller Parts	5
Install the Secure Digital Card	6
Mount the System	6
Connect Power to the Controller	7
Wire the Embedded I/O Modules	9
Connect the Controller to an EtherNet/IP Network	9
Connect to the USB Port	9
Specifications	10
Additional Resources	10

CompactLogix™ 5370 L1 controllers can operate in various applications and are part of the Integrated Architecture® system. A controller system includes:

- Embedded 24V DC isolated power supply
- Embedded dual Ethernet ports
- Embedded I/O modules
- USB port for programming purposes
- A protective end cap
- Support for 1734 POINT I/O™ modules
- Support for Integrated Motion over an EtherNet/IP™ network with some controllers in the family

## Summary of Changes

This publication contains the following new or updated information. This list includes substantive updates only and isn't intended to reflect all changes.

Topic	Page
Updated to include series C controller information	Throughout



**ATTENTION:** Read this document and the documents listed in the Additional Resources section about installation, configuration and operation of this equipment before you install, configure, operate or maintain this product. Users are required to familiarize themselves with installation and wiring instructions in addition to requirements of all applicable codes, laws, and standards.

Activities including installation, adjustments, putting into service, use, assembly, disassembly, and maintenance are required to be carried out by suitably trained personnel in accordance with applicable code of practice. If this equipment is used in a manner not specified by the manufacturer, the protection provided by the equipment may be impaired.

注意：在安装、配置、操作和维护本产品前，请阅读本文档以及“其他资源”部分列出的有关设备安装、配置和操作的相应文档。除了所有适用规范、法律和标准的相关要求之外，用户还必须熟悉安装和接线说明。

安装、调整、投运、使用、组装、拆卸和维护等各项操作必须由经过适当训练的专业人员按照适用的操作规范实施。

如果未按照制造商指定的方式使用该设备，则可能会损害设备提供的保护。

**ATENCIÓN:** Antes de instalar, configurar, poner en funcionamiento o realizar el mantenimiento de este producto, lea este documento y los documentos listados en la sección Recursos adicionales acerca de la instalación, configuración y operación de este equipo. Los usuarios deben familiarizarse con las instrucciones de instalación y cableado y con los requisitos de todos los códigos, leyes y estándares vigentes.

El personal debidamente capacitado debe realizar las actividades relacionadas a la instalación, ajustes, puesta en servicio, uso, ensamblaje, desensamblaje y mantenimiento de conformidad con el código de práctica aplicable. Si este equipo se usa de una manera no especificada por el fabricante, la protección provista por el equipo puede resultar afectada.

**ATENÇÃO:** Leia este e os demais documentos sobre instalação, configuração e operação do equipamento que estão na seção Recursos adicionais antes de instalar, configurar, operar ou manter este produto. Os usuários devem se familiarizar com as instruções de instalação e fiação além das especificações para todos os códigos, leis e normas aplicáveis.

É necessário que as atividades, incluindo instalação, ajustes, colocação em serviço, utilização, montagem, desmontagem e manutenção sejam realizadas por pessoal qualificado e especializado, de acordo com o código de prática aplicável.

Caso este equipamento seja utilizado de maneira não estabelecida pelo fabricante, a proteção fornecida pelo equipamento pode ficar prejudicada.

**ВНИМАНИЕ:** Перед тем как устанавливать, настраивать, эксплуатировать или обслуживать данное оборудование, прочитайте этот документ и документы, перечисленные в разделе «Дополнительные ресурсы». В этих документах изложены сведения об установке, настройке и эксплуатации данного оборудования. Пользователи обязаны ознакомиться с инструкциями по установке и прокладке соединений, а также с требованиями всех применимых норм, законов и стандартов.

Все действия, включая установку, наладку, ввод в эксплуатацию, использование, сборку, разборку и техническое обслуживание, должны выполняться обученным персоналом в соответствии с применимыми нормами и правилами.

Если оборудование используется не предусмотренным производителем образом, защита оборудования может быть нарушена.

注意：本製品を設置、構成、稼働または保守する前に、本書および本機器の設置、設定、操作についての参考資料の該当箇所に記載されている文書に目を通してください。ユーザは、すべての該当する条例、法律、規格の要件に加えて、設置および配線の手順に習熟している必要があります。

設置調整、運転の開始、使用、組立て、解体、保守を含む諸作業は、該当する実施規則に従って訓練を受けた適切な作業員が実行する必要があります。

本機器が製造メーカーにより指定されていない方法で使用されている場合、機器により提供されている保護が損なわれる恐れがあります。

**ACHTUNG:** Lesen Sie dieses Dokument und die im Abschnitt „Weitere Informationen“ aufgeführten Dokumente, die Informationen zu Installation, Konfiguration und Bedienung dieses Produkts enthalten, bevor Sie dieses Produkt installieren, konfigurieren, bedienen oder warten. Anwender müssen sich neben den Bestimmungen aller anwendbaren Vorschriften, Gesetze und Normen zusätzlich mit den Installations- und Verdrahtungsanweisungen vertraut machen.

Arbeiten im Rahmen der Installation, Anpassung, Inbetriebnahme, Verwendung, Montage, Demontage oder Instandhaltung dürfen nur durch ausreichend geschulte Mitarbeiter und in Übereinstimmung mit den anwendbaren Ausführungsvorschriften vorgenommen werden.

Wenn das Gerät in einer Weise verwendet wird, die vom Hersteller nicht vorgesehen ist, kann die Schutzfunktion beeinträchtigt sein.

**ATTENTION:** Lisez ce document et les documents listés dans la section Ressources complémentaires relatifs à l'installation, la configuration et le fonctionnement de cet équipement avant d'installer, configurer, utiliser ou entretenir ce produit. Les utilisateurs doivent se familiariser avec les instructions d'installation et de câblage en plus des exigences relatives aux codes, lois et normes en vigueur. Les activités relatives à l'installation, le réglage, la mise en service, l'utilisation, l'assemblage, le démontage et l'entretien doivent être réalisées par des personnes formées selon le code de pratique en vigueur.

Si cet équipement est utilisé d'une façon qui n'a pas été définie par le fabricant, la protection fournie par l'équipement peut être compromise.

주의：본 제품 설치, 설정, 작동 또는 유지 보수하기 전에 본 문서를 포함하여 설치, 설정 및 작동에 관한 참고 자료 섹션의 문서들을 반드시 읽고 숙지하십시오. 사용자는 모든 관련 규정, 법규 및 표준에서 요구하는 사항에 대해 반드시 설치 및 배선 지침을 숙지해야 합니다.

설치, 조정, 가동, 사용, 조립, 분해, 유지보수 등 모든 작업은 관련 규정에 따라 적절한 교육을 받은 사용자들 통해서만 수행해야 합니다.

본 장비를 제조사가 명시하지 않은 방법으로 사용하면 장비의 보호 기능이 손상될 수 있습니다.

**ATTENZIONE** Prima di installare, configurare ed utilizzare il prodotto, o effettuare interventi di manutenzione su di esso, leggere il presente documento ed i documenti elencati nella sezione "Altre risorse", riguardanti l'installazione, la configurazione ed il funzionamento dell'apparecchiatura. Gli utenti devono leggere e comprendere le istruzioni di installazione e cablaggio, oltre ai requisiti previsti dalle leggi, codici e standard applicabili.

Le attività come installazione, regolazioni, utilizzo, assemblaggio, disassemblaggio e manutenzione devono essere svolte da personale adeguatamente addestrato, nel rispetto delle procedure previste. Qualora l'apparecchio venga utilizzato con modalità diverse da quanto previsto dal produttore, la sua funzione di protezione potrebbe venire compromessa.

**DİKKAT:** Bu ürünün kurulumu, yapılandırılması, işletilmesi veya bakımı öncesinde bu dokümanı ve bu ekipmanın kurulumu, yapılandırılması ve işletimi ile ilgili ilave Kaynaklar bölümünde yer listelenmiş dokümanları okuyun. Kullanıcılar yürürlükteki tüm yönetmelikler, yasalar ve standartların gereksinimlerine ek olarak kurulum ve kablolama talimatlarını da öğrenmek zorundadır.

Kurulum, ayarlama, hizmete alma, kullanma, parçaları birleştirme, parçaları sökme ve bakım gibi aktiviteler sadece uygun eğitimleri almış kişiler tarafından yürürlükteki uygulama yönetmeliklerine uygun şekilde yapılabilir.

Bu ekipman üretici tarafından belirlenmiş amacın dışında kullanılırsa, ekipman tarafından sağlanan koruma bozulabilir.

注意事項：在安装、設定、操作或維護本产品前，請先閱讀此文件以及列於「其他資源」章節中有關安裝、設定與操作此設備的文件。使用者必須熟悉安裝和配線指示，並符合所有法規、法律和標準要求。

包括安裝、調整、交付使用、使用、組裝、拆卸和維護等動作都必須交由已經適當訓練的人員進行，以符合適用的實作法規。

如果將設備用於非製造商指定的用途時，可能會造成設備所提供的保護功能受損。

**POZOR:** Než začnete instalovat, konfigurovat či provozovat tento výrobek nebo provádět jeho údržbu, přečtěte si tento dokument a dokumenty uvedené v části Dodatečné zdroje ohledně instalace, konfigurace a provozu tohoto zařízení. Uživatelé se musejí vedle požadavků všech relevantních vyhlášek, zákonů a norem nutně seznámit také s pokyny pro instalaci a elektrické zapojení.

Činnosti zahrnující instalaci, nastavení, uvedení do provozu, užívání, montáž, demontáž a údržbu musí vykonávat vhodně proškolený personál v souladu s příslušnými prováděcími předpisy.

Pokud se toto zařízení používá způsobem neodpovídajícím specifikaci výrobce, může být narušena ochrana, kterou toto zařízení poskytuje.

**UWAGA:** Przed instalacją, konfiguracją, użytkowaniem lub konserwacją tego produktu należy przeczytać niniejszy dokument oraz wszystkie dokumenty wymienione w sekcji Dodatkowe źródła omawiające instalację, konfigurację i procedury użytkowania tego urządzenia. Użytkownicy mają obowiązek zapoznać się z instrukcjami dotyczącymi instalacji oraz oprzewodowania, jak również z obowiązującymi kodeksami, prawem i normami.

Działania obejmujące instalację, regulację, przekazanie do użytkowania, użytkowanie, montaż, demontaż oraz konserwację muszą być wykonywane przez odpowiednio przeszkolony personel zgodnie z obowiązującym kodeksem postępowania.

Jeśli urządzenie jest użytkowane w sposób inny niż określony przez producenta, zabezpieczenie zapewniane przez urządzenie może zostać ograniczone.

**OBBS!** Läs detta dokument samt dokumentet, som står listat i avsnittet Övriga resurser, om installation, konfigurering och drift av denna utrustning innan du installerar, konfigurerar eller börjar använda eller utföra underhållsarbete på produkten. Användare måste bekanta sig med instruktioner för installation och kabeldragning, förutom krav enligt gällande koder, lagar och standarder.

Åtgärder som installation, justering, service, användning, montering, demontering och underhållsarbete måste utföras av personal med lämplig utbildning enligt lämpligt bruk.

Om denna utrustning används på ett sätt som inte anges av tillverkaren kan det hända att utrustningens skyddsanordningar försätts ur funktion.

**LET OP:** Lees dit document en de documenten die genoemd worden in de paragraaf Aanvullende informatie over de installatie, configuratie en bediening van deze apparatuur voordat u dit product installeert, configureert, bediend of onderhoudt. Gebruikers moeten zich vertrouwd maken met de installatie en de bedradingsinstructies, naast de vereisten van alle toepasselijke regels, wetten en normen.

Activiteiten zoals het installeren, afstellen, in gebruik stellen, gebruiken, monteren, demonteren en het uitvoeren van onderhoud mogen uitsluitend worden uitgevoerd door hiervoor opgeleid personeel en in overeenstemming met de geldende praktijkregels.

Indien de apparatuur wordt gebruikt op een wijze die niet is gespecificeerd door de fabrikant, dan bestaat het gevaar dat de beveiliging van de apparatuur niet goed werkt.



**ATTENTION:**

- Before installing, configuring, operating, or maintaining this product, read this document and the documents that are listed in the Additional Resources section for installing, configuring, or operating equipment. Users should familiarize themselves with installation and wiring instructions in addition to requirements of all applicable codes, laws, and standards.
- Installation, adjustments, putting into service, use, assembly, disassembly, and maintenance shall be carried out by suitably trained personnel in accordance with applicable code of practice. In case of malfunction or damage, no attempts at repair should be made. The module should be returned to the manufacturer for repair. Do not dismantle the module.
- If this equipment is used in a manner not specified by the manufacturer, the protection provided by the equipment may be impaired.
- This equipment is certified for use only within the surrounding air temperature range of -20...+60 °C (-4...+140 °F). The equipment must not be used outside of this range.

**IMPORTANT**

Any illustrations, charts, sample programs, and layout examples shown in this publication are intended solely for the purposes of example. Since there are many variables and requirements associated with any particular installation, Rockwell Automation does not assume responsibility or liability for actual use based upon the examples that are shown in this publication.

**Environment and Enclosure**





**ATTENTION:** This equipment is intended for use in a Pollution Degree 2 industrial environment, in overvoltage Category II applications (as defined in EN/IEC 60664-1), at altitudes up to 2000 m (6562 ft) without derating. This equipment isn't intended for use in residential environments and may not provide adequate protection to radio communication services in such environments.

This equipment is supplied as open-type equipment. It must be mounted within an enclosure that is suitably designed for those specific environmental conditions that will be present and appropriately designed to prevent personal injury resulting from accessibility to live parts. The enclosure must have suitable flame-retardant properties to prevent or minimize the spread of flame, complying with a flame spread rating of 5VA or be approved for application if nonmetallic. The interior of the enclosure must be accessible only by the use of a tool. Subsequent sections of this publication may contain additional information regarding specific enclosure-type ratings that are required to comply with certain product safety certifications.

In addition to this publication, see the following:

- Industrial Automation Wiring and Grounding Guidelines, publication 1770-4.1 for more installation requirements
- NEMA 250 and EN/IEC 60529, as applicable, for explanations of the degrees of protection provided by enclosure

**North American Hazardous Location Approval**

The following information applies when operating this equipment in hazardous locations.	Informations sur l'utilisation de cet équipement en environnements dangereux.
<p>Products marked "CL I, DIV 2, GP A, B, C, D" are suitable for use in Class I Division 2 Groups A, B, C, D, Hazardous Locations and nonhazardous locations only. Each product is supplied with markings on the rating nameplate indicating the hazardous location temperature code. When combining products within a system, the most adverse temperature code (lowest "T" number) may be used to help determine the overall temperature code of the system. Combinations of equipment in your system are subject to investigation by the local Authority Having Jurisdiction at the time of installation.</p>	<p>Les produits marqués "CL I, DIV 2, GP A, B, C, D" ne conviennent qu'à une utilisation en environnements de Classe I Division 2 Groupes A, B, C, D dangereux et non dangereux. Chaque produit est livré avec des marquages sur sa plaque d'identification qui indiquent le code de température pour les environnements dangereux. Lorsque plusieurs produits sont combinés dans un système, le code de température le plus défavorable (code de température le plus faible) peut être utilisé pour déterminer le code de température global du système. Les combinaisons d'équipements dans le système sont sujettes à inspection par les autorités locales qualifiées au moment de l'installation.</p>
<div style="display: flex; align-items: flex-start;">  <div> <p><b>WARNING:</b> <b>Explosion Hazard -</b></p> <ul style="list-style-type: none"> <li>• Do not disconnect equipment unless power has been removed or the area is known to be nonhazardous.</li> <li>• Do not disconnect connections to this equipment unless power has been removed or the area is known to be nonhazardous. Secure any external connections that mate to this equipment by using screws, sliding latches, threaded connectors, or other means provided with this product.</li> <li>• Substitution of components may impair suitability for Class I, Division 2.</li> </ul> </div> </div>	<div style="display: flex; align-items: flex-start;">  <div> <p><b>AVERTISSEMENT:</b> <b>Risque d'Explosion -</b></p> <ul style="list-style-type: none"> <li>• Couper le courant ou s'assurer que l'environnement est classé non dangereux avant de débrancher l'équipement.</li> <li>• Couper le courant ou s'assurer que l'environnement est classé non dangereux avant de débrancher les connecteurs. Fixer tous les connecteurs externes reliés à cet équipement à l'aide de vis, loquets coulissants, connecteurs filetés ou autres moyens fournis avec ce produit.</li> <li>• La substitution de composants peut rendre cet équipement inadapté à une utilisation en environnement de Classe I, Division 2.</li> </ul> </div> </div>

**UK and European Hazardous Location Approval**

The following applies to products marked Ⓢ II 3 G. Such modules:

- Are Equipment Group II, Equipment Category 3, and comply with the Essential Health and Safety Requirements relating to the design and construction of such equipment given in Schedule 1 of UKEX regulation 2016 No.1107 and Annex II to EU Directive 2014/34/EU. See the UKEX and EU Declaration of Conformity at [rok.auto/certifications](http://rok.auto/certifications) for details.
- Provide protection type Ex ec IIC T4 Gc according to EN IEC 60079-7.
- Comply to Standards: EN IEC 60079-0:2018, EN IEC 60079-7:2015+A1:2018, reference certificate number UL 21 ATEX 2603X and UL22UKEX2515X.
- Are intended for use in areas in which explosive atmospheres caused by gases, vapors, mists, or air are unlikely to occur, or are likely to occur only infrequently and for short periods. Such locations correspond to Zone 2 classification according to UKEX regulation 2016 No.1107 and ATEX directive 2014/34/EU.
- May have catalog numbers that end in "K" to indicate conformal coating.

### Special Conditions for Safe Use

---



**WARNING:**

- The equipment shall be mounted in a UKEX/ATEX Zone 2 certified enclosure with a minimum ingress protection rating of at least IP54 (in accordance with EN IEC 60079-0) and used in an environment of not more than Pollution Degree 2 (as defined in EN/IEC 60664-1). The enclosure must be accessible only by the use of a tool.
  - This equipment must be used within its specified ratings that are defined by Rockwell Automation.
  - Provisions shall be made to prevent the rated voltage from being exceeded by transient disturbances of more than 140% of the peak rated voltage when applied in Zone 2 environments.
  - Secure any external connections that mate to this equipment by using screws, sliding latches, threaded connectors, or other means provided with this product.
  - Do not disconnect equipment unless power has been removed or the area is known to be nonhazardous.
  - Enclosure must be marked with the following: "Warning - Do not open when energized." After installation of equipment into the enclosure, access to termination compartments must be dimensioned so that conductors can be readily connected.
  - The instructions in the user manual shall be observed.
  - This equipment must be used only with UKEX/ATEX certified Rockwell Automation backplanes.
  - Earthing is accomplished through mounting of modules on rail.
  - This equipment isn't resistant to sunlight or other sources of UV radiation.
- 

### Prevent Electrostatic Discharge

---



**ATTENTION:** This equipment is sensitive to electrostatic discharge, which can cause internal damage and affect normal operation. Follow these guidelines when you handle this equipment:

- Touch a grounded object to discharge potential static.
  - Wear an approved grounding wriststrap.
  - Do not touch connectors or pins on component boards.
  - Do not touch circuit components inside the equipment.
  - Use a static-safe workstation, if available.
  - Store the equipment in appropriate static-safe packaging when not in use.
- 

### Removal and Insertion Under Power

---



**WARNING:** If you insert or remove the module while backplane power is on, an electric arc can occur. This could cause an explosion in hazardous location installations. Be sure that power is removed or the area is nonhazardous before proceeding.

---

## Before You Begin

The CompactLogix 5370 L1, series B and C controller redesigns occurred to provide an option to use one external power supply for system power and field side power. There are differences between the CompactLogix 5370 L1, series A, B, and C controllers. Consider the following before installing a CompactLogix 5370 L1 controller:

- The embedded power supply for the following controllers is a 24V DC nominal, non-isolated power supply with an input range of 10...28.8V DC. You wire the embedded power supply via a removable connector.

Series	Catalog Number
A	1769-L16ER-BB1B
	1769-L18ER-BB1B
	1769-L18ERM-BB1B

- The embedded power supply for the following controllers is a 24V DC nominal, isolated power supply. The input range of the power supply is 10...28.8V DC. You wire the embedded power supply via a removable connector.

Series	Catalog Number
B and C	1769-L16ER-BB1B
	1769-L18ER-BB1B
	1769-L18ERM-BB1B
A and C	1769-L18ERM-BB1BK
	1769-L19ER-BB1B
	1769-L19ER-BB1BK

### IMPORTANT

You must use a dedicated external Class 2/SELV-approved power supply to provide power to the system, according to the needs of the application, and within the operating voltage range of the controller for only series A 1769-L16ER-BB1B, 1769-L18ER-BB1B, or 1769-L18ERM-BB1B controllers. You can't use the external power supply that provides power to the embedded power supply of the controller to provide power to any other components or devices in the application for only series A 1769-L16ER-BB1B, 1769-L18ER-BB1B, or 1769-L18ERM-BB1B controllers.

- The following controllers require a second, fused external power supply to provide power to other components.

Series	Catalog Number
A	1769-L16ER-BB1B
	1769-L18ER-BB1B
	1769-L18ERM-BB1B

- The following controllers allow the external power supply that provides power to the system to also provide power to other components.

Series	Catalog Number
B and C	1769-L16ER-BB1B
	1769-L18ER-BB1B
	1769-L18ERM-BB1B
A and C	1769-L18ERM-BB1BK
	1769-L19ER-BB1B
	1769-L19ER-BB1BK

## Controller Parts

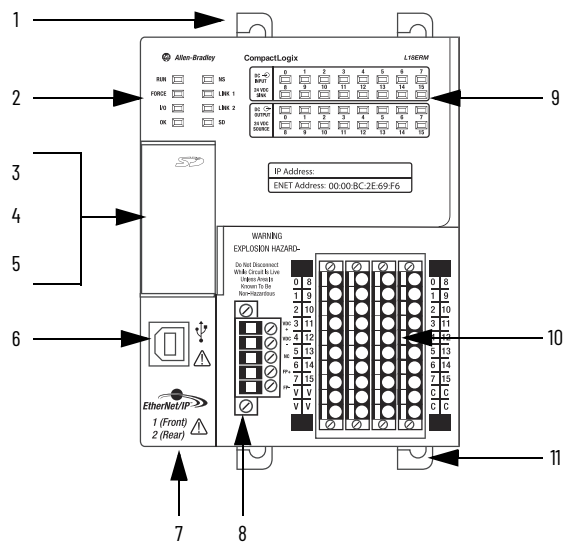

### CompactLogix 5370 L1 Controller Parts

Number	Item	Description
1	Top DIN rail latches	Secures the controller to the DIN rail.
2	Controller status indicators	Show the state of the controller
3	SD card slot	Located behind the door, SD card location
4	Mode switch	Located behind the door, lets you choose the controller mode
5	Reset button	Located behind the door, lets you reset the controller to factory default state
6	USB programming port	Temporary connection to download projects
7	Ethernet ports A and B	On the bottom of the controller, connects the to an EtherNet/IP network
8	Power removable terminal block (RTB)	Connects external power supply to the controller
9	I/O status indicators	Show the state of the embedded I/O modules
10	I/O module RTB	Connects devices to the embedded I/O modules
11	Bottom DIN rail latches	Secures controller to the DIN rail

An SD card and a protective end cap ship with the controller.

## Install the Secure Digital Card



**WARNING:** When you insert or remove the SD card while power is on, an electric arc can occur. This could cause an explosion in hazardous location installations.

When you change switch settings while power is on, an electric arc can occur. This could cause an explosion in hazardous location installations.

The USB port is intended for temporary local programming purposes only and not intended for permanent connection. If you connect or disconnect the USB cable with power applied to this module or any device on the USB network, an electric arc can occur. This could cause an explosion in a hazardous location installation.

Do not use the USB port in hazardous locations.

Be sure that power is removed or the area is nonhazardous before proceeding.

1. Verify that the SD card is locked or unlocked according to your preference. Consider the following when deciding to lock the card before installation:
  - If the card is unlocked, the controller can write data to it or read data from it.
  - If the card is locked, the controller can only read data from it and you can experience issues when updating the firmware on your controller.
2. Open the SD card door.

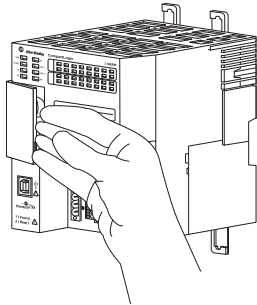

3. Insert the SD card into the SD card slot. You can install the SD card in only one orientation. The beveled corner is at the **top**.

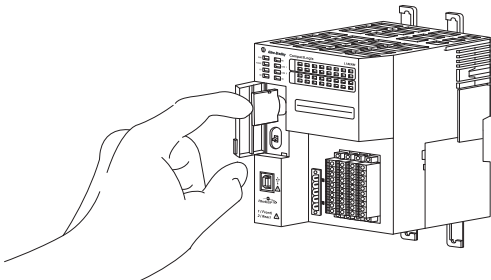

If you feel resistance when inserting the SD card, take it out and change the orientation.

4. Gently press the card until it clicks into place.
5. Close the SD card door.

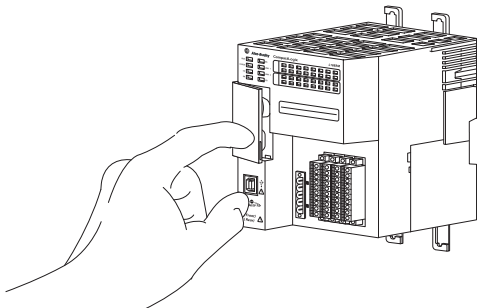

## Mount the System

CompactLogix 5370 L1 control systems are mounted on a DIN rail. Install the DIN rail before completing the steps that are required to install the system.



**WARNING:** When used in a Class I, Division 2, hazardous location, this equipment must be mounted in a suitable enclosure with proper wiring that complies with the governing electrical codes.

## Available DIN Rails

You can mount the CompactLogix 5370 L1 controller on the following DIN rails:

- EN 50 022 - 35 x 7.5 mm (1.38 x 0.30 in.)
- EN 50 022 - 35 x 15 mm (1.38 x 0.59 in.)

**IMPORTANT** You must install bumpers on the back of your CompactLogix 5370 L1 controller before mounting it on the EN 50022 - 35 x 15 mm (1.38 x 0.59 in.) DIN rail. For more information about Bumper Selection, see Knowledgebase Technote, [5370 L16ER/L18ER recommended Bumpers for use with 1.38 x 0.59 in. DIN rail](#)

## Minimum Spacing

Maintain spacing from enclosure walls, wireways, and adjacent equipment. Allow 50 mm (2 in.) of space on all sides, as shown. This provides ventilation and electrical isolation.

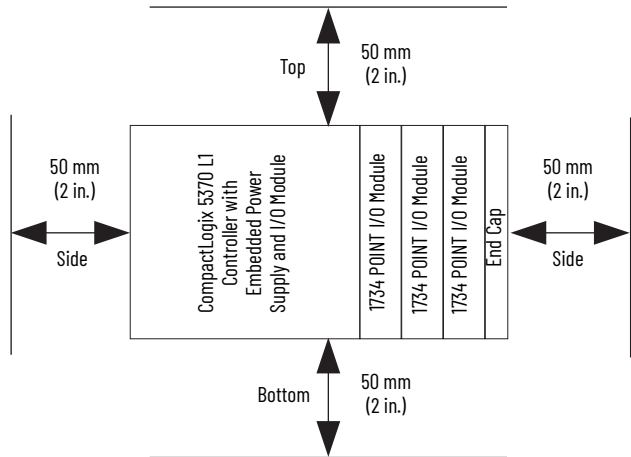

## System Dimensions

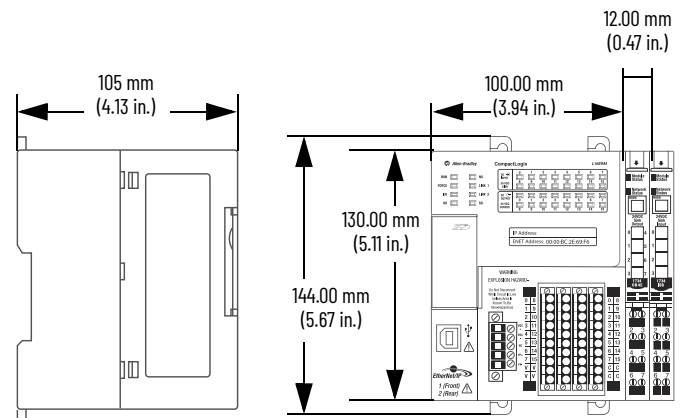

## Ground the System



**ATTENTION:** This product is intended to be mounted to a well-grounded mounting surface. Additional grounding connections from the power supply's mounting tabs or DIN rail aren't required unless the mounting surface can't be grounded. See, *Industrial Automation Wiring and Grounding Guidelines*, publication [1770-4.1](#), for additional information.

## Install the Controller

Complete these steps to install the controller.

1. Pull locking tabs out.

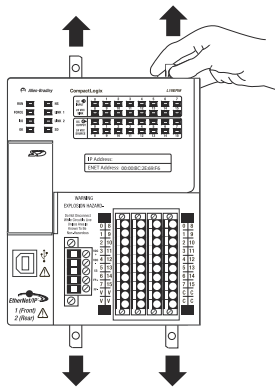

2. Slide the controller into position on the DIN rail and push the locking tabs back in place.

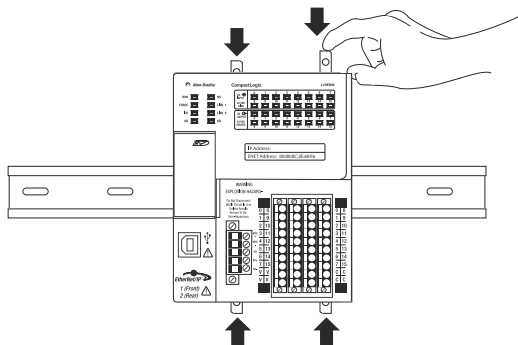

3. If you aren't using local expansion modules, use the tongue-and-groove slots on the right side of the controller to slide the included end cap onto the controller. The end cap covers the exposed interconnections on the right side of the controller.

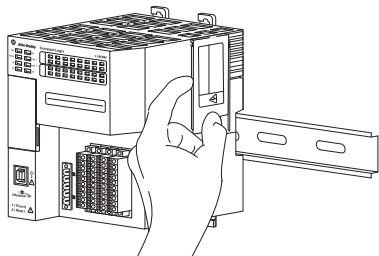

**ATTENTION:** Failure to use an end cap could result in equipment damage or injury from electric shock.

## Connect Power to the Controller

**IMPORTANT** This section describes how to power the controller via the VDC+ and VDC- terminals.

Connections to the VDC+ and VDC- terminals do not provide power to input or output devices that are connected to the embedded I/O modules of the controller or local expansion modules. Power must be connected to the FP+ and FP- terminals to provide power to input or output devices that are connected to the embedded I/O modules of the controller or local expansion modules.

The external power supply can be used to power both the VDC+/- and FP+/- terminals on CompactLogix 5370 L1 series B and C controllers.



**WARNING:** Do not connect directly to line voltage. Line voltage must be supplied by a suitable, approved isolating transformer or power supply with short circuit capacity not exceeding 100VA maximum or equivalent. Controller power requirement is 30VA.

Power is connected to the controller via a removable connector that is on the front of the controller.

**IMPORTANT** This section assumes that any DIN rail that you use has been grounded following *Industrial Automation Wiring and Grounding Guidelines*, publication [1770-4.1](#). The controller is grounded once it's installed on a grounded DIN rail.

Consider these points before completing the steps in this section:

- This section describes how to connect an external 24V DC power source to the CompactLogix 5370 L1 controller.
- Use a power source that most effectively meets your application needs. That is, calculate the power requirements for your application before choosing a power source to avoid using a power source that far exceeds your application requirements.
- The embedded power supply of the CompactLogix 5370 L1 controller provides power to the controller and POINTBus™ backplane.
- Not all Class 2/SELV-listed power supplies are certified for use in all applications, for example, use in nonhazardous and hazardous environments.

Before installing an external power supply, consult all specification and certification information to verify that you're using an acceptable external power supply.

- For example purposes only, this section describes how to use a 1606-XLE120E, NEC Class 2 switched-mode power supply. The exact steps for other external power supplies can vary from the steps that are described here.

Complete the following steps to connect power to the CompactLogix 5370 L1 control system.

1. Verify that the external 24V DC power source isn't powered.
2. Mount the external 24V DC power source on a DIN rail.  
The external 24V DC power source can be installed on the same DIN rail as the controller or a separate DIN rail.
3. Connect the wires to the 24V DC+ and 24V DC- connections on the external 24V DC power source.



**WARNING:** If you connect or disconnect wiring while the field-side power is on, an electric arc can occur. This could cause an explosion in hazardous location installations. Be sure that power is removed or the area is nonhazardous before proceeding.

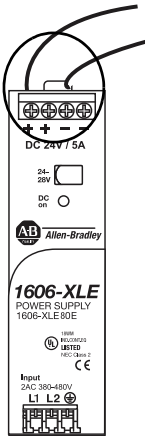

4. Pull the removable connector off the CompactLogix 5370 L1 controller.

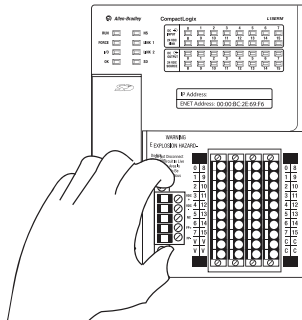

5. Connect the wire that is connected to the 24V DC+ terminal on the external 24V DC power source to the VDC+ terminal. The VDC+ terminal is the top terminal on the removable connector.

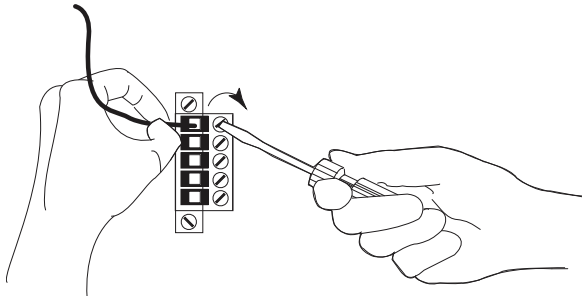

6. Connect the wire that is connected to the 24V DC- terminal on the external 24V DC power source to the VDC- terminal. The VDC- terminal is the second from the top on the removable connector.

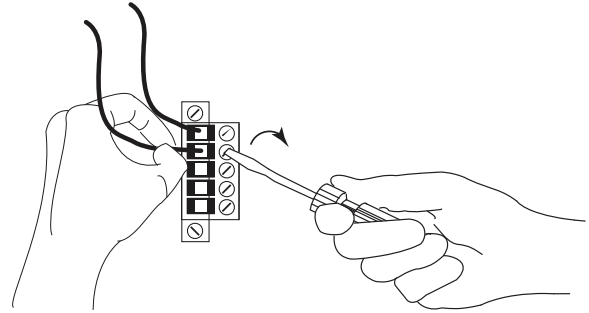

**IMPORTANT** If your application requires a power control device, for example, a switch or relay, between the external 24V DC power source and the CompactLogix 5370 L1 controller to control when the controller is powered, you must install the power control device at the VDC+ terminal on the removable connector.  
If you install the power control device at the VDC- terminal, the CompactLogix 5370 L1 controller can have problems powering up or powering down properly.

7. Plug the removable connector back into the controller.
8. To secure it in place, use the screws at the top and bottom of the removable connector.
9. Turn on power to the external 24V DC power source.

The following graphic shows an external 24V DC power source that is connected to a CompactLogix 5370 L1 controller.

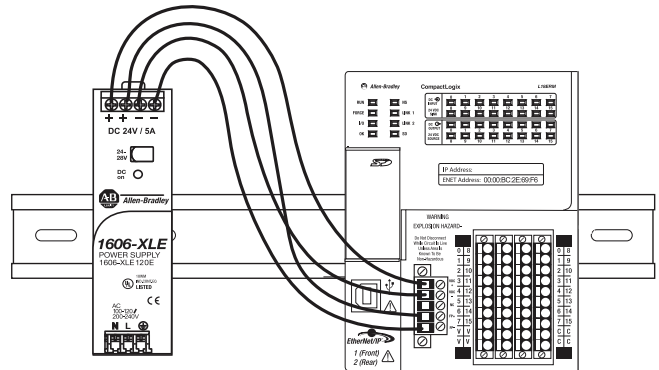

CompactLogix 5370 Controllers have an embedded, battery-less Energy Storage Module (ESM) that provides power to the CPU upon power-down, allowing the controller to write customer application and tag data to the on-board flash memory. In some cases, the ESM will continue to provide enough power to keep the wall clock active until its residual stored energy is depleted.

## Wire the Embedded I/O Modules

CompactLogix 5370 L1 controllers provide 16-point DC embedded I/O modules. The following graphic shows the embedded I/O module terminals.

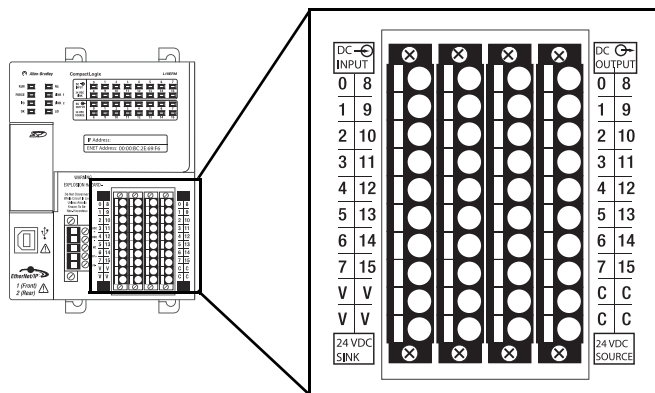

Complete the following steps to **wire the input and output points** on the CompactLogix 5370 L1 controller.

1. Verify that the control system isn't powered.
2. Use a small screwdriver to push the spring release clip and insert the wire.

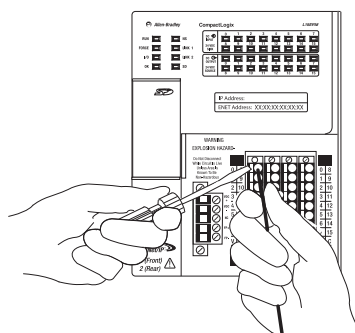

3. With the wire in place, pull the screwdriver off the spring release clip.
4. Repeat [step 2](#) for all embedded I/O wires needed in your application.

To **remove a wire** from the removable connector, complete the following steps.

1. Verify that the control system isn't powered.
2. Use a small screwdriver to push the spring release clip and remove the wire.

To remove and replace an I/O module connector, complete the following steps.

1. Verify that the control system isn't powered.
2. Use a small screwdriver to loosen the screws that secure the connector to the module.

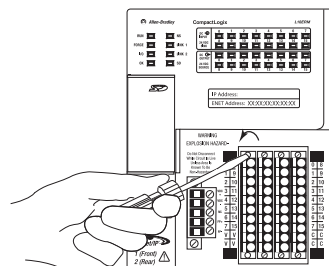

3. Pull the connector out of the module.
4. Disconnect any wires from the connector.
5. Connect any wires to the replacement connector.
6. Push the replacement connector back into the I/O module.
7. Secure the connector to the I/O module with a small screwdriver.

## Connect the Controller to an EtherNet/IP Network



**WARNING:** If you connect or disconnect the communication cable with power applied to this module or any device on the network, an electric arc can occur. This could cause an explosion in hazardous location installations. Be sure that power is removed or the area is nonhazardous before proceeding.

Connect the RJ45 connector of the Ethernet cable to one of the Ethernet ports on the controller. The ports are on the bottom of the controller.

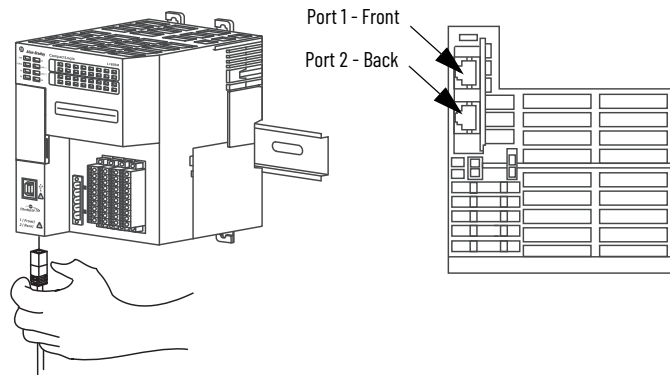

## Connect to the USB Port

The controller has a USB port that uses a Type B receptacle. The port is USB 2.0-compatible and operates at 12 Mbps.

Use a USB cable to connect your computer to the USB port. With this connection, you can update firmware and download programs to the controller directly from your computer.



**ATTENTION:** The USB port is intended only for temporary local programming purposes and not intended for permanent connection. The USB cable isn't to exceed 3.0 m (9.84 ft) and must not contain hubs.



**WARNING:** Do not use the USB port in hazardous locations.

Plug the USB cable into the CompactLogix 5370 L1 controller.

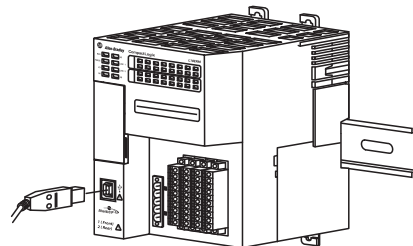

For more information on how to supply power to a CompactLogix 5370 L1 controller, how to use the Ethernet or USB ports, or to see examples of devices connected to the embedded I/O modules, refer to the CompactLogix 5370 Controllers User Manual, publication [1769-UM021](#).

## Specifications

Attribute	1769-L16ER-BB1B, 1769-L18ER-BB1B, 1769-L18ERM-BB1B, 1769-L18ERM-BB1BK, 1769-L19ER-BB1B, 1769-L19ER-BB1BK
Current draw @ 5V DC, controller power	1 A
Current draw @ 24V DC, field power max	3 A <sup>(1)</sup>
Power dissipation	11.5 W
Wire screw torque	0.5...0.6 N•m (0.37...0.44 lb•ft)
Wire sizes	Power Terminal: 0.2...2.5 mm <sup>2</sup> (24...14 AWG) solid or stranded copper wire that is rated at 75 °C (167 °F), or greater, 1.2 mm (3/64 in.) insulation max Input Terminal: 0.205...1.31 mm <sup>2</sup> (24...16 AWG) solid or stranded copper wire that is rated at 75 °C (167 °F), or greater, 1.2 mm (3/64 in.) insulation max or 90 °C (194 °F)
Wire type, Ethernet	RJ45 connector according to IEC 60603-7, 2 or 4 pair Category 5e minimum cable according to TIA 568-B.1 or Category 5 cable according to ISO/IEC 24702

(1) Combined total for all devices drawing current from field power connections.

## Additional Resources

These documents contain additional information concerning related products from Rockwell Automation.

Resource	Description
CompactLogix Controllers Specifications Technical Data, publication <a href="#">1769-TD005</a>	Provides technical data and specifications for CompactLogix controllers.
CompactLogix 5370 Controllers User Manual, publication <a href="#">1769-UM021</a>	Provides information on how to install, configure, program, and use CompactLogix controllers.
Ethernet Reference Manual, <a href="#">ENET-RM002</a>	Describes basic Ethernet concepts, infrastructure components, and infrastructure features.
UL Standards Listing for Industrial Control Products, publication <a href="#">CMPNTS-SR002</a>	Assists original equipment manufacturers (OEMs) with construction of panels, to help ensure that they conform to the requirements of Underwriters Laboratories.
Industrial Components Preventive Maintenance, Enclosures, and Contact Ratings Specifications, publication <a href="#">IC-TD002</a>	Provides a quick reference tool for Allen-Bradley industrial automation controls and assemblies.
Safety Guidelines for the Application, Installation, and Maintenance of Solid-state Control, publication <a href="#">SGI-1.1</a>	Designed to harmonize with NEMA Standards Publication No. ICS 1.1-1987 and provides general guidelines for the application, installation, and maintenance of solid-state control in the form of individual devices or packaged assemblies incorporating solid-state components.
Industrial Automation Wiring and Grounding Guidelines, publication <a href="#">1770-4.1</a>	Provides general guidelines for installing a Rockwell Automation industrial system.
Product Certifications website, <a href="#">rok.auto/certifications</a>	Provides declarations of conformity, certificates, and other certification details.

You can view or download publications at [rok.auto/literature](#).

**Notes:**

# Rockwell Automation Support

Use these resources to access support information.

<b>Technical Support Center</b>	Find help with how-to videos, FAQs, chat, user forums, and product notification updates.	<a href="http://rok.auto/support">rok.auto/support</a>
<b>Knowledgebase</b>	Access Knowledgebase articles.	<a href="http://rok.auto/knowledgebase">rok.auto/knowledgebase</a>
<b>Local Technical Support Phone Numbers</b>	Locate the telephone number for your country.	<a href="http://rok.auto/phonesupport">rok.auto/phonesupport</a>
<b>Literature Library</b>	Find installation instructions, manuals, brochures, and technical data publications.	<a href="http://rok.auto/literature">rok.auto/literature</a>
<b>Product Compatibility and Download Center (PCDC)</b>	Download firmware, associated files (such as AOP, EDS, and DTM), and access product release notes.	<a href="http://rok.auto/pcdc">rok.auto/pcdc</a>

## Documentation Feedback

Your comments help us serve your documentation needs better. If you have any suggestions on how to improve our content, complete the form at [rok.auto/docfeedback](http://rok.auto/docfeedback).





## Waste Electrical and Electronic Equipment (WEEE)



At the end of life, this equipment should be collected separately from any unsorted municipal waste.

Rockwell Automation maintains current product environmental compliance information on its website at [rok.auto/pec](http://rok.auto/pec).

Rockwell Otomasyon Ticaret A.Ş. Kar Plaza İş Merkezi E Blok Kat:6 34752 İçerenköy, İstanbul, Tel: +90 (216) 5698400 EEE Yönetmeliğine Uygundur

Connect with us.    

**rockwellautomation.com** — expanding **human possibility**<sup>®</sup>

AMERICAS: Rockwell Automation, 1201 South Second Street, Milwaukee, WI 53204-2496 USA, Tel: (1) 414.382.2000, Fax: (1) 414.382.4444

EUROPE/MIDDLE EAST/AFRICA: Rockwell Automation NV, Pegasus Park, De Kleetlaan 12a, 1831 Diegem, Belgium, Tel: (32) 2 663 0600, Fax: (32) 2 663 0640

ASIA PACIFIC: Rockwell Automation, Level 14, Core F, Cyberport 3, 100 Cyberport Road, Hong Kong, Tel: (852) 2887 4788, Fax: (852) 2508 1846

Allen-Bradley, CompactLogix, expanding human possibility, Integrated Architecture, POINT I/O, POINTBus, and Rockwell Automation are trademarks of Rockwell Automation, Inc.

EtherNet/IP is a trademark of ODVA, Inc.

Trademarks not belonging to Rockwell Automation are property of their respective companies.

Publication 1769-IN029C-EN-P - November 2022 | Supersedes Publication 1769-IN029B-EN-P - November 2022

Copyright © 2022 Rockwell Automation, Inc. All rights reserved. Printed in the U.S.A.

PN-676909