

Armor CompactLogix Controllers

Catalog Numbers 1769-L33ERMO, 1769-L36ERMO, 1769-L37ERMO, 1769-L38ERMO

Topic	Page
About the Armor CompactLogix Controller	3
Parts List	4
Required Components	4
Mount the Controller	4
Ground the Controller	5
Make Power Connections	5
Open the Enclosure Access Door	5
Remove and Install the Memory Card	6
Connect to the USB Port	6
Make Network Connections	7
Set the Network IP Address	8
Update the Controller	10
Create a Controller Project	11
Status Indicators	11
Reset the Controller	12
Recover the Controller By Using a Memory Card	13
Replace the Fuse	13
Clean the Controller	13
Specifications	14
Waste Electrical and Electronic Equipment (WEEE)	14
	14



ATTENTION: Read this document and the documents listed in the Additional Resources section about installation, configuration and operation of this equipment before you install, configure, operate or maintain this product. Users are required to familiarize themselves with installation and wiring instructions in addition to requirements of all applicable codes, laws, and standards. Activities including installation, adjustments, putting into service, use, assembly, disassembly, and maintenance are required to be carried out by suitably trained personnel in accordance with applicable code of practice.

If this equipment is used in a manner not specified by the manufacturer, the protection provided by the equipment may be impaired.

注意: 在安装、配置、操作和维护本产品前，请阅读本文档以及“其他资源”部分列出的有关设备安装、配置和操作的相应文档。除了所有适用规范、法律和标准的相关要求之外，用户还必须熟悉安装和接线说明。

安装、调整、投运、使用、组装、拆卸和维护等各项操作必须由经过适当训练的专业人员按照适用的操作规范实施。

如果未按照制造商指定的方式使用该设备，则可能会损害设备提供的保护。

ATENCIÓN: Antes de instalar, configurar, poner en funcionamiento o realizar el mantenimiento de este producto, lea este documento y los documentos listados en la sección Recursos adicionales acerca de la instalación, configuración y operación de este equipo. Los usuarios deben familiarizarse con las instrucciones de instalación y cableado y con los requisitos de todos los códigos, leyes y estándares vigentes.

El personal debidamente capacitado debe realizar las actividades relacionadas a la instalación, ajustes, puesta en servicio, uso, ensamblaje, desensamblaje y mantenimiento de conformidad con el código de práctica aplicable.

Si este equipo se usa de una manera no especificada por el fabricante, la protección provista por el equipo puede resultar afectada.

ATENÇÃO: Leia este e os demais documentos sobre instalação, configuração e operação do equipamento que estão na seção Recursos adicionais antes de instalar, configurar, operar ou manter este produto. Os usuários devem se familiarizar com as instruções de instalação e fiação além das especificações para todos os códigos, leis e normas aplicáveis.

É necessário que as atividades, incluindo instalação, ajustes, colocação em serviço, utilização, montagem, desmontagem e manutenção sejam realizadas por pessoal qualificado e especializado, de acordo com o código de prática aplicável.

Caso este equipamento seja utilizado de maneira não estabelecida pelo fabricante, a proteção fornecida pelo equipamento pode ficar prejudicada.

ВНИМАНИЕ: Перед тем как устанавливать, настраивать, эксплуатировать или обслуживать данное оборудование, прочитайте этот документ и документы, перечисленные в разделе «Дополнительные ресурсы». В этих документах изложены сведения об установке, настройке и эксплуатации данного оборудования. Пользователи обязаны ознакомиться с инструкциями по установке и прокладке соединений, а также с требованиями всех применимых норм, законов и стандартов.

Все действия, включая установку, наладку, ввод в эксплуатацию, использование, сборку, разборку и техническое обслуживание, должны выполняться обученным персоналом в соответствии с применимыми нормами и правилами.

Если оборудование используется не предусмотренным производителем образом, защита оборудования может быть нарушена.

注意: 本製品を設置、構成、稼動または保守する前に、本書および本機器の設置、設定、操作についての参考資料の該当箇所に記載されている文書に目を通してください。ユーザは、すべての該当する条例、法律、規格の要件に加えて、設置および配線の手順に習熟している必要があります。

設置調整、運転の開始、使用、組立て、解体、保守を含む諸作業は、該当する実施規則に従って訓練を受けた適切な作業員が実行する必要があります。本機器が製造メーカーにより指定されていない方法で使用されている場合、機器により提供されている保護が損なわれる恐れがあります。

ACHTUNG: Lesen Sie dieses Dokument und die im Abschnitt „Weitere Informationen“ aufgeführten Dokumente, die Informationen zu Installation, Konfiguration und Bedienung dieses Produkts enthalten, bevor Sie dieses Produkt installieren, konfigurieren, bedienen oder warten. Anwender müssen sich neben den Bestimmungen aller anwendbaren Vorschriften, Gesetze und Normen zusätzlich mit den Installations- und Verdrahtungsanweisungen vertraut machen.

Arbeiten im Rahmen der Installation, Anpassung, Inbetriebnahme, Verwendung, Montage, Demontage oder Instandhaltung dürfen nur durch ausreichend geschulte Mitarbeiter und in Übereinstimmung mit den anwendbaren Ausführungsvorschriften vorgenommen werden.

Wenn das Gerät in einer Weise verwendet wird, die vom Hersteller nicht vorgesehen ist, kann die Schutzfunktion beeinträchtigt sein.

ATTENTION: Lisez ce document et les documents listés dans la section Ressources complémentaires relatifs à l'installation, la configuration et le fonctionnement de cet équipement avant d'installer, configurer, utiliser ou entretenir ce produit. Les utilisateurs doivent se familiariser avec les instructions d'installation et de câblage en plus des exigences relatives aux codes, lois et normes en vigueur.

Les activités relatives à l'installation, le réglage, la mise en service, l'utilisation, l'assemblage, le démontage et l'entretien doivent être réalisées par des personnes formées selon le code de pratique en vigueur. Si cet équipement est utilisé d'une façon qui n'a pas été définie par le fabricant, la protection fournie par l'équipement peut être compromise.

주의: 본 제품 설치, 설정, 작동 또는 유지 보수하기 전에 본 문서를 포함하여 설치, 설정 및 작동에 관한 참고 자료 섹션의 문서들을 반드시 읽고 숙지하십시오. 사용자는 모든 관련 규정, 법규 및 표준에서 요구하는 사항에 대해 반드시 설치 및 배선 지침을 숙지해야 합니다.

설치, 조정, 가동, 사용, 조립, 분해, 유지보수 등 모든 작업은 관련 규정에 따라 적절한 교육을 받은 사용자를 통해서만 수행해야 합니다.

본 장비를 제조사가 명시하지 않은 방법으로 사용하면 장비의 보호 기능이 손상될 수 있습니다.

ATTENZIONE: Prima di installare, configurare ed utilizzare il prodotto, o effettuare interventi di manutenzione su di esso, leggere il presente documento ed i documenti elencati nella sezione "Altre risorse", riguardanti l'installazione, la configurazione ed il funzionamento dell'apparecchiatura. Gli utenti devono leggere e comprendere le istruzioni di installazione e cablaggio, oltre ai requisiti previsti dalle leggi, codici e standard applicabili.

Le attività come installazione, regolazioni, utilizzo, assemblaggio, disassemblaggio e manutenzione devono essere svolte da personale adeguatamente addestrato, nel rispetto delle procedure previste.

Qualora l'apparecchio venga utilizzato con modalità diverse da quanto previsto dal produttore, la sua funzione di protezione potrebbe venire compromessa.

DİKKAT: Bu ürünün kurulumu, yapılandırılması, işletilmesi veya bakımı öncesinde bu dokümanı ve bu ekipmanın kurulumu, yapılandırılması ve işletimi ile ilgili ilave Kaynaklar bölümünde yer listelenmiş dokümanları okuyun. Kullanıcılar yürürlükteki tüm yönetmelikler, yasalar ve standartların gereksinimlerine ek olarak kurulum ve kablolama talimatlarını da öğrenmek zorundadır.

Kurulum, ayarlama, hizmete alma, kullanma, parçaları birleştirme, parçaları sökme ve bakım gibi aktiviteler sadece uygun eğitimleri almış kişiler tarafından yürürlükteki uygulama yönetmeliklerine uygun şekilde yapılabilir.

Bu ekipman üretici tarafından belirlenmiş amacın dışında kullanılırsa, ekipman tarafından sağlanan koruma bozulabilir.

注意事項: 在安装、設定、操作或維護本產品前，請先閱讀此文件以及列於「其他資源」章節中有關安裝、設定與操作此設備的文件。使用者必須熟悉安裝和配線指示，並符合所有法規、法律和標準要求。

包括安裝、調整、交付使用、使用、組裝、拆卸和維護等動作都必須交由已經過適當訓練的人員進行，以符合適用的實作法規。

如果將設備用於非製造商指定的用途時，可能會造成設備所提供的保護功能受損。

POZOR: Než začnete instalovat, konfigurovat či provázet tento výrobek nebo provádět jeho údržbu, přečtěte si tento dokument a dokumenty uvedené v části Dodatečné zdroje ohledně instalace, konfigurace a provozu tohoto zařízení. Uživatelé se musejí vedle požadavků všech relevantních vyhlášek, zákonů a norem nutně seznámit také s pokyny pro instalaci a elektrické zapojení.

Činnosti zahrnující instalaci, nastavení, uvedení do provozu, užívání, montáž, demontáž a údržbu musí vykonávat vhodně proškolený personál v souladu s příslušnými prováděcími předpisy.

Pokud se toto zařízení používá způsobem neodpovídajícím specifikaci výrobce, může být narušena ochrana, kterou toto zařízení poskytuje.

UWAGA: Przed instalacją, konfiguracją, użytkowaniem lub konserwacją tego produktu należy przeczytać niniejszy dokument oraz wszystkie dokumenty wymienione w sekcji Dodatkowe źródła omawiające instalację, konfigurację i procedury użytkowania tego urządzenia. Użytkownicy mają obowiązek zapoznać się z instrukcjami dotyczącymi instalacji oraz oprezwodowania, jak również z obowiązującymi kodeksami, prawem i normami.

Działania obejmujące instalację, regulację, przekazanie do użytkowania, użytkowanie, montaż, demontaż oraz konserwację muszą być wykonywane przez odpowiednio przeszkolony personel zgodnie z obowiązującym kodeksem postępowania.

Jeśli urządzenie jest użytkowane w sposób inny niż określony przez producenta, zabezpieczenie zapewniane przez urządzenie może zostać ograniczone.

ORS! Läs detta dokument samt dokumentet, som står listat i avsnittet Övriga resurser, om installation, konfigurering och drift av denna utrustning innan du installerar, konfigurerar eller börjar använda eller utföra underhållsarbete på produkten. Användare måste bekanta sig med instruktioner för installation och kabeldragning, förutom krav enligt gällande koder, lagar och standarder.

Åtgärder som installation, justering, service, användning, montering, demontering och underhållsarbete måste utföras av personal med lämplig utbildning enligt lämpligt bruk.

Om denna utrustning används på ett sätt som inte anges av tillverkaren kan det hända att utrustningens skyddsanordningar försätts ur funktion.

LET OP: Lees dit document en de documenten die genoemd worden in de paragraaf Aanvullende informatie over de installatie, configuratie en bediening van deze apparatuur voordat u dit product installeert, configureert, bedient of onderhoudt. Gebruikers moeten zich vertrouwd maken met de installatie en de bedradinginstructies, naast de vereisten van alle toepasselijke regels, wetten en normen.

Activiteiten zoals het installeren, afstellen, in gebruik stellen, gebruiken, monteren, demonteren en het uitvoeren van onderhoud mogen uitsluitend worden uitgevoerd door hiervoor opgeleid personeel en in overeenstemming met de geldende praktijkregels.

Indien de apparatuur wordt gebruikt op een wijze die niet is gespecificeerd door de fabrikant, dan bestaat het gevaar dat de beveiliging van de apparatuur niet goed werkt.

About the Armor CompactLogix Controller

The Armor™ CompactLogix™ controller combines the controller, which features built-in EtherNet/IP connectivity, with a power supply in an IP67-rated housing for mounting on a machine.



ATTENTION: In case of malfunction or damage, no attempts at repair should be made. The module should be returned to the manufacturer for repair. Do not dismantle the module.



Prevent Electrostatic Discharge



ATTENTION: This equipment is sensitive to electrostatic discharge, which can cause internal damage and affect normal operation. Follow these guidelines when you handle this equipment:

- Touch a grounded object to discharge potential static.
- Wear an approved grounding wriststrap.
- Do not touch connectors or pins on component boards.
- Do not touch circuit components inside the equipment.
- Use a static-safe workstation, if available.
- Store the equipment in appropriate static-safe packaging when not in use.

Environment and Enclosure



ATTENTION: This equipment is intended for use in overvoltage Category II applications (as defined in EN/IEC 60664-1), at altitudes up to 2000 m (6562 ft) without derating.

This equipment is not intended for use in residential environments and may not provide adequate protection to radio communication services in such environments.

This equipment is supplied as enclosed equipment. It should not require additional system enclosure when used in locations consistent with the equipment Enclosure Type Ratings. Subsequent sections of this publication may contain more information regarding specific enclosure type ratings, beyond what this product provides, that are required to comply with certain product safety certifications.

In addition to this publication, see the following:

- Industrial Automation Wiring and Grounding Guidelines, publication [1770-4.1](#), for more installation requirements.
- NEMA Standard 250 and EN/IEC 60529, as applicable, for explanations of the degrees of protection provided by enclosures.

Electrical Safety Considerations



ATTENTION: Power to this equipment must be supplied from a source compliant with the following:

- Limited Voltage Supply compliant with UL508.
- External overcurrent protection requirements, 8 A max.

Parts List

The controller is shipped with the 1784-SD1 Secure Digital memory card installed.

Control power and Ethernet communication cables are available separately.

Required Components

This section includes Control power and Ethernet communication cables.

Cordsets

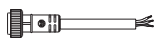
	No. of Pins	Assembly Rating	Straight Female	Right Angle Female
	4	600V, 10 A	889N-F4AFC ^{(1)F}	889N-R4AFC ^{(1)F}



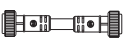

(1) Replace (1) with 6 (6 ft), 12 (12 ft), or 20 (20 ft) for standard cable lengths.

Patchcords

	No. of Pins	Assembly Rating	Straight Female, Straight Male	Straight Female, Right-Angle Male	Right-Angle Female, Straight Male	Right-Angle Female, Right-Angle Male
	4	600V, 10 A	889N-F4AFNM ⁽¹⁾	889N-F4AFNE ⁽¹⁾	889N-R4AFNM ⁽¹⁾	889N-R4AFNE ⁽¹⁾

(1) Replace (1) with 1 (1 m), 2 (2 m), 5 (5 m), or 10 (10 m) for standard cable lengths.

Industrial Ethernet Media

Patchcords and Cordsets IP67			
M12 D Code	Connector Type	Cat. No. Unshielded	
	Male straight to Male straight	1585D-M4TBDM ⁽¹⁾	
	Male straight to Male right angle	1585D-M4TBDE ⁽¹⁾	
	Male right angle to Male right angle	1585D-E4TBDE ⁽¹⁾	
	Male straight to Female straight	1585D-M4TBDF ⁽¹⁾	

(1) Available in 0.3, 0.6, 1, 2, 5, 10, 15, and increments of 5 meters up to 75 meters.

TIP See <http://ab.rockwellautomation.com/Connection-Devices/EtherNet-Media> for more information on Industrial Ethernet Media.

Mount the Controller

Observe these minimum spacing requirements around the enclosure.

Mounting feet can be attached in either horizontal or vertical orientation as shown in [Product Dimensions, mm \(in.\) on page 4](#). Attach the mounting feet to the enclosure by using the four flat-head screws that are supplied with the mounting feet. Torque screws to 8.5 N•m (75.2 lb•in).

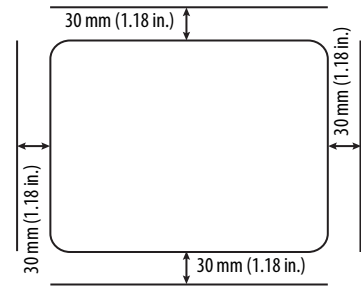

Mount the module directly to a machine by using four mounting holes. The mounting hole diameter on the mounting feet included with the enclosure is 6.8 mm (0.27 in.). Use four M6 screws and torque screws to 6.6 N•m (58 lb•in). See the [Product Dimensions, mm \(in.\) on page 4](#).

Product Dimensions, mm (in.)

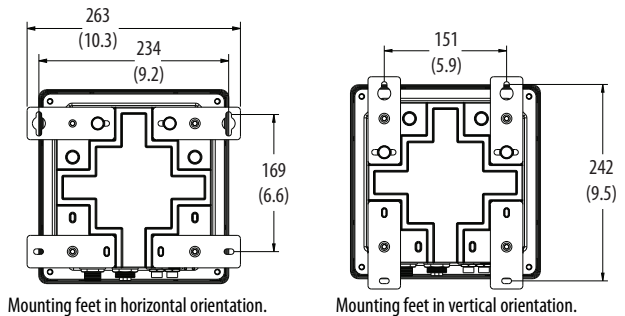
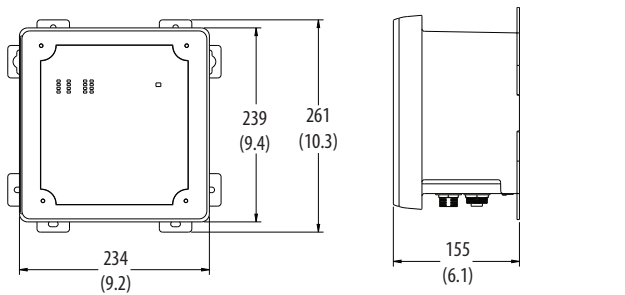

Mounting feet in horizontal orientation.

Mounting feet in vertical orientation.

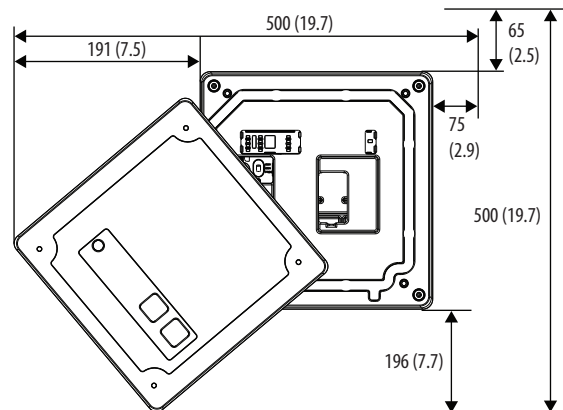

Clearance for access door opening.

Ground the Controller

You must provide a proper grounding path by using the ground screw on the bottom of the enclosure.

To attach grounding wires by using a ring lug, follow these steps.

1. Remove the grounding screw.
2. Attach a ring lug.
3. Replace and tighten the grounding screw.

To attach grounding wires by using a fork connector, follow these steps.



1. Loosen the grounding screw.
2. Slide a fork connector underneath.
3. Tighten the grounding screw.

PE Ground	Wire Size	Torque
	1.3...5.2 mm ² (16...10 AWG)	2 N•m (17.7 in•lb)

See Industrial Automation Wiring and Grounding Guidelines, publication [1770-4.1](#), for guidelines on how to install an industrial control system.

Make Power Connections

This section describes the power connections for the controller.

Male Connector (power input)	Female Connector (power output)	Pin	Signal
		1	V+ Switched
		2	V+ Unswitched
		3	V- Unswitched Common
		4	V- Switched Common

The bottom of the enclosure has two sealed mini-style power connectors that operate in parallel with one another to allow daisy-chaining of device power with other devices. The unit receives its required power through the male connector.

The female connector lets power be daisy-chained to another ArmorStart®, Armor ControlLogix®, Armor CompactLogix®, or On-Machine™ I/O product.

IMPORTANT On Machine end devices, such as the Armor CompactLogix controller, use the EN-50044 wiring standard while On-Machine cordsets with flying leads use the SAE-J-1738A standard for wiring. Be sure to follow the pin numbering convention that is shown here before powering up the unit.

Cordsets with Flying Leads (per SAE-J-1738A)

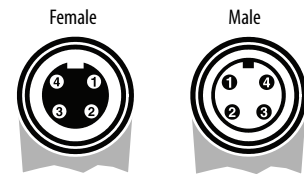

1-Black [V-], 2-White [E-], 3-Red [V+], 4-Green [E+]

Patchcord with Quick Disconnect Connectors (per EN 50044)

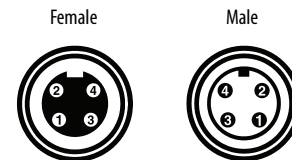

1-Red [V+], 2-Green [E+], 3- White [E-], 4-Black [V-]

1. Remove the dust cap from the female power connector on the bottom of the enclosure.

IMPORTANT If you disconnect power connections from these ports, reattach the dust cap and finger-tighten.

2. Make power connections and tighten to hand tight plus one half-turn.



ATTENTION: Make sure that all connectors and caps are securely tightened to properly seal the connections against leaks and maintain IP enclosure type requirements.

Open the Enclosure Access Door

The controller is shipped in the Remote Program mode. You can make power connections and EtherNet/IP network connections without opening the access door on the enclosure.

The enclosure access door provides access to the following items:

- Controller mode toggle switch
- Controller memory card socket
- Controller USB port
- Controller reset button
- Power supply fuse circuitry

To open the enclosure access door, follow these steps.

1. Loosen the four (captive) screws on the front of the enclosure.
2. Gently lift the door and rotate from the pivot at the lower left corner.

The door remains attached to the enclosure and does not detach.

3. Close the access door on the enclosure and torque the four screws to 3.8 N•m (33.5 lb•in).

IMPORTANT When the access door is open, the Armor CompactLogix controller rating is UL Type 1.

When you close the access door, you must torque the four screws to 3.8 N·m (33.5 lb·in) for an IP67 rating.

Do not remove or damage the gasket when opening or closing the access door. A missing or damaged gasket can reduce the IP rating of the enclosure.

Do not damage or remove the overlay. A damaged or removed overlay can reduce the IP rating of the enclosure.

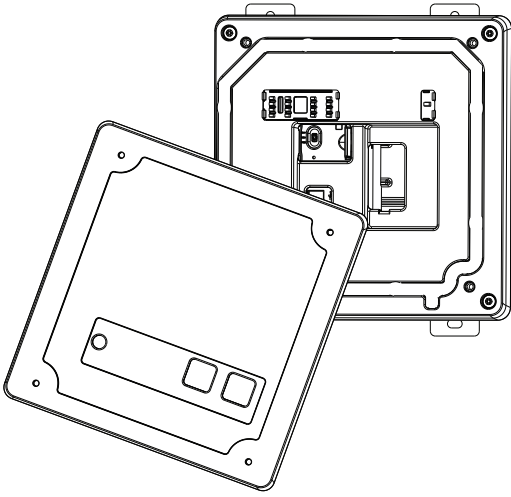

Remove and Install the Memory Card

To remove the memory card, follow these steps.

IMPORTANT Verify that the memory card status indicator is off and that the card is not in use before removing it.

1. Open the access door on the enclosure.
2. Turn the toggle switch to the PROG position.
3. To eject the memory card, press and release the memory card.

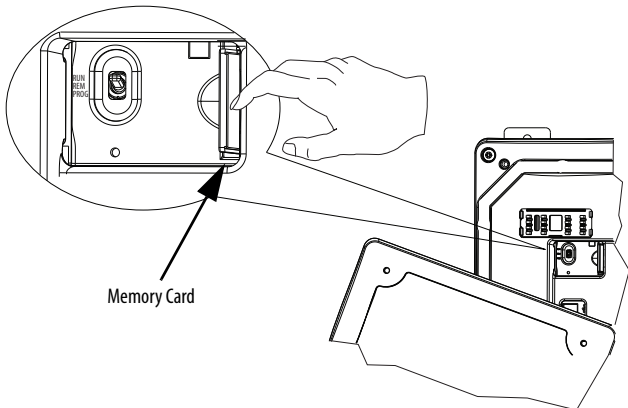

4. Remove the memory card.
5. Close the enclosure access door and torque the four screws to 3.8 N·m (33.5 lb·in).

To install the memory card, follow these steps.



ATTENTION: If you are not sure of the contents of the memory card, before you install the memory card, turn the toggle switch of the controller to the PROG position. Depending on the contents of the card, a power cycle or fault can cause the card to load a different project or operating system into the controller.

1. Open the access door on the enclosure.
2. Verify that the memory card is locked or unlocked according to your preference.

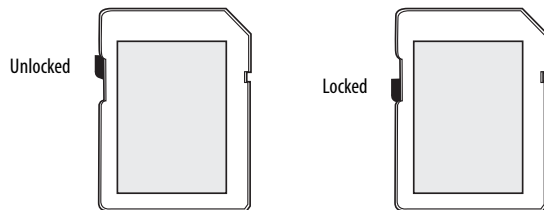

3. Insert the memory card into the memory card slot.

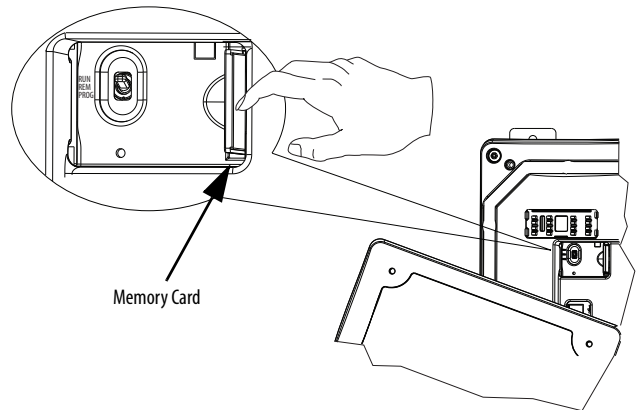

4. Gently press the memory card until it clicks into place.
5. Close the enclosure access door and torque the four screws to 3.8 N·m (33.5 lb·in).

Connect to the USB Port

The controller has a USB port that uses a Type B receptacle. The port is USB 2.0-compatible and runs at 12 Mbps. To use the USB port of the controller, you must have RSLinx® software, version 3.74 or later, installed on your workstation.

Access the USB port by opening the enclosure access door.

Use a USB cable to connect your workstation to the USB port. With this connection, you can update firmware and download programs to the controller directly from your workstation.



ATTENTION: The USB port is intended for temporary local programming purposes only and not intended for permanent connection.

The USB cable is not to exceed 3.0 m (9.84 ft) and must not contain hubs.

To configure RSLinx software to use a USB port, you must configure a USB driver. To configure a USB driver, follow these steps. If you are using Windows 7 operating system, the driver is automatically installed and you can go ahead to [step 5](#).

1. Connect your controller and workstation by using a USB cable.
2. On the Found New Hardware Wizard dialog box, click one of the Windows Update connection options and click Next.

TIP If the software for the USB driver is not found and the installation is canceled, verify that you have installed RSLinx® Classic software, version 3.74 or later.

3. Click Install the software automatically (Recommended) and click Next.
4. Click Finish.
5. To browse to your controller in RSLinx software, click

RSWho .

In the RSLinx Workstation organizer, your controller appears under two different drivers, a virtual chassis and the USB port. You can use either driver to browse to your controller.

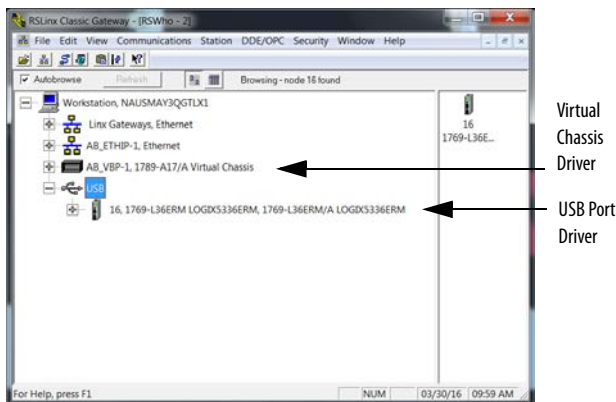

Make Network Connections

The two EtherNet/IP networks in the enclosure let the Armor CompactLogix controller be used in various EtherNet/IP network topologies. Topologies include linear, star, and Device Level Ring (DLR), as a ring node or ring supervisor.

For more information on EtherNet/IP networks, see the publications that are listed in [on page 14](#).

1. Remove the dust caps from the two Ethernet connectors on the bottom of the enclosure.

IMPORTANT If you disconnect network connections from these ports, reattach the dust caps and finger-tighten.

2. Connect the cordsets that you selected to the Ethernet communication ports on the bottom of the enclosure and torque to 1 N•m (9 lb•in).

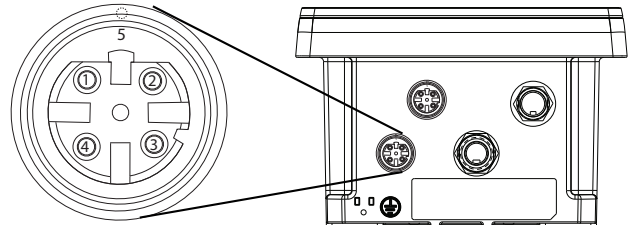

- Pin 1 – M12_Tx+
- Pin 2 – M12_Rx+
- Pin 3 – M12_Tx-
- Pin 4 – M12_Rx-
- Pin 5 – Connector Shell Shield GND

D-Code M12 Female Network Connector



ATTENTION: Make sure that all connectors and caps are securely tightened to properly seal the connections against leaks and maintain IP enclosure type requirements.



ATTENTION: Be advised that when you use a shielded Ethernet cable, this product terminates the shield to chassis ground through the Ethernet connector bulkheads. If another component that ties its Ethernet connector bulkhead to ground is connected to this product with a shielded Ethernet cable, a ground loop is created.

When you use shielded Ethernet cable, follow the guidelines for use of shielded cable, most importantly the guidelines for eliminating ground loops. For information on eliminating ground loops, see the 'ODVA EtherNet/IP Media Planning and Installation Manual,' available on the ODVA website.

For more information on how to select cables for EtherNet/IP Networks, see the Guidance for Selecting Cables for EtherNet/IP Networks White Paper, publication [ENET-WP007](#).

IMPORTANT Use the 1585D–M4DC–H: Polyamide small body unshielded or the 1585D–M4DC–SH: Zinc die-cast large body shielded mating connectors for the D-Code M12 female network connector.

IMPORTANT Use two twisted-pair CAT5E UTP or STP cables.

D-Code M12 Pin	Wire Color	Signal	8-way Modular RJ45 Pin
1	White-Orange	TX+	1
2	White-Green	RX+	3
3	Orange	TX-	2
4	Green	RX-	6

Set the Network IP Address

To set the IP address of each module, use one of these methods.

- BOOTP/DHCP server (see [page 8](#))
- RSLinx Classic software (see [page 9](#))
- Studio 5000 Logix Designer® application (see [page 9](#))
- Memory card (see [page 10](#))



ATTENTION: Assign a fixed network address to the CompactLogix 5370 controllers. Do not assign a dynamic IP address to the controllers.

Failure to observe this precaution can result in unintended machine motion or loss of process control.

See the EtherNet/IP publications that are listed in [on page 14](#) for detailed information on setting an IP address.

Use a BOOTP/DHCP Server

The BOOTP/DHCP server is a standalone server that you can use to set an IP address. The BOOTP/DHCP server sets an IP address and other Transport Control Protocol (TCP) parameters.

Access the BOOTP/DHCP server from one of these locations:

- Programs > Rockwell Software > BOOTP-DHCP Server
If you have not installed the server, you can download and install it from <http://www.ab.com/networks/ethernet/bootp.html>.
- Tools directory on the Studio 5000® environment installation CD.

IMPORTANT Before you start the BOOTP/DHCP server, make sure that you have the hardware (MAC) address of the module. The MAC ID label is on the front of the cover, underneath the faceplate. Rotate the faceplate to see the MAC ID label.

Follow these steps to set the IP address of the module by using a BOOTP/DHCP server.

1. Start the BOOTP/DHCP software.
2. From the Tools menu, choose Network Settings.



3. Type the Subnet Mask of the network.

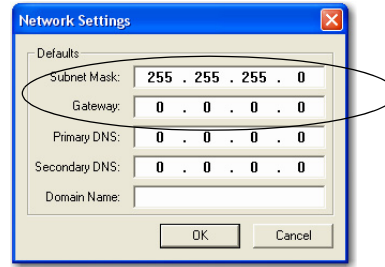

The Gateway address, Primary and/or Secondary DNS address, and Domain Name fields are optional.

4. Click OK.

The Request History panel shows the hardware addresses of all modules that issue BOOTP requests.

5. Select the appropriate module and click Add to Relation List.

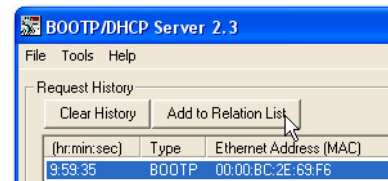

6. On the New Entry dialog box, type an IP address, host name, and description for the module.

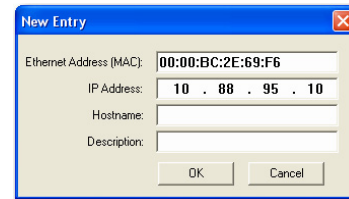

7. Click OK.
8. To assign this configuration to the module permanently, wait for the module to appear in the Relation List panel and select it.
9. Click Disable BOOTP/DHCP.

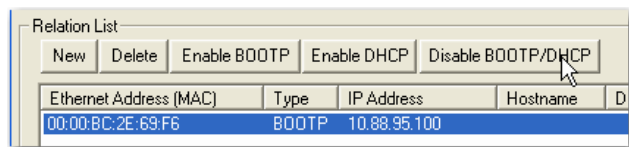

IMPORTANT If you do not click Disable BOOTP/DHCP, the host controller clears the current IP configuration and begins sending BOOTP requests again each time that power is cycled.

Use RSLinx or the Logix Designer Application

This table describes when to set the network IP address with RSLinx software or the Logix Designer application.

Conditions	Use	Page
A BOOTP server is not available. The EtherNet/IP communication module is connected to another NetLinx network.	RSLinx software	9
The Logix Designer project is online with a controller that communicates to or through the EtherNet/IP communication module.	Logix Designer application	9

Set the Network IP Address with RSLinx Software

To use RSLinx software to set the IP address, follow these steps.

1. From the Communications menu, choose RSWHo.
2. From the RSWHo dialog box, navigate to the USB network.
3. Right-click the controller and choose Module Configuration.

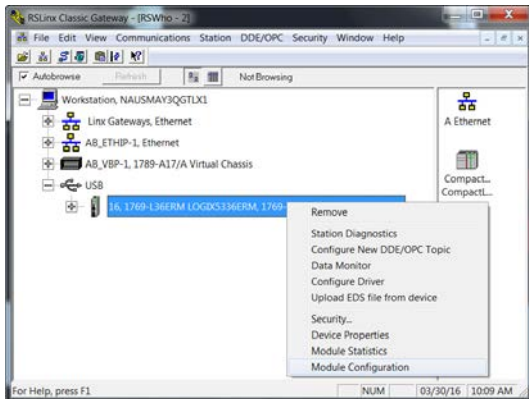

4. On the Module Configuration dialog box, click the Port Configuration tab.

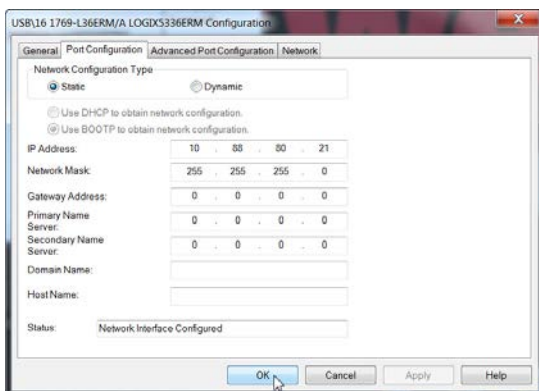

5. For Network Configuration Type, click Static to assign this configuration to the port permanently.

IMPORTANT If you click Dynamic, on a power cycle, the controller clears the current IP configuration and sends BOOTP requests.

6. Type the IP address in the IP Address field and complete more fields, if needed.
7. Configure the port settings.

To	Then
Use the default port speed and duplex settings	Leave Auto-negotiate port speed and duplex checked. This setting determines the actual speed and duplex setting.
Manually configure the speed and duplex settings of your port	Follow these steps. 1. Clear the Auto-negotiate port speed and duplex checkbox. 2. From the Current Port Speed pull-down menu, choose a port speed. 3. From the Current Duplex pull-down menu, choose the appropriate Duplex value, that is, half-duplex or full-duplex.

IMPORTANT Consider the following when you configure the port settings:

- If the module is connected to an unmanaged switch, leave Auto-negotiate port speed and duplex checked, or communication can be impaired.
- If you are forcing the port speed and duplex with a managed switch, the corresponding port of the managed switch must be forced to the same settings or the module fails.

8. Click OK.

Set the Network IP Address with the Logix Designer Application

To use the Logix Designer application to set the IP address of the module, follow these steps.

1. In the Controller Organizer, right-click the controller and choose Properties.

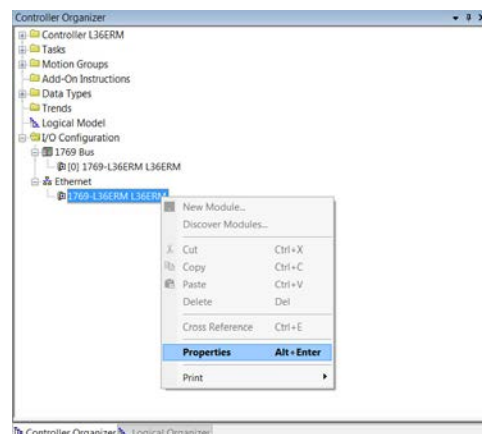

- On the Controller Properties dialog box, click the Internet Protocol tab.

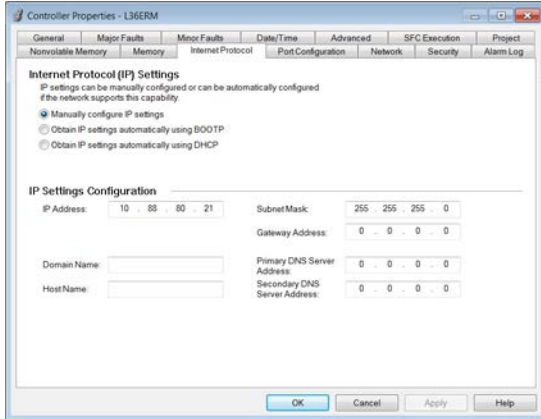

- In the Physical Module IP Address field, type the IP address.
- In the other fields, type the other network parameters, if needed.
- Click Apply.
- Click OK.

Use the Memory Card

You can use a memory card to set the IP address for a CompactLogix 5370 controller. By using the memory card to set the IP address, you eliminate the need for software to complete this task.

IMPORTANT To set the IP address from a memory card, software is not required during the powerup process. However, you must have previously saved the project to the memory card.

The IP address of the Compact CompactLogix 5370 controller is automatically configured at power-up as long as you have configured an IP address, stored the program onto a controller, and set the memory card to the Load Image parameter set to On Power Up.

The option to set the IP address of a CompactLogix 5370 controller via a memory card at powerup is only one part of the process to load an entire project to the controller from the memory card.

Use this option carefully. For example, the memory card can contain a desirable IP address as part of an undesirable project. For example, a project that is older than the project currently used on the controller.

To set the IP address on a CompactLogix 5370 controller with a memory card, these requirements apply:

- A project must be stored on the memory card.
- The project that is stored on the memory card is configured with the Load Image parameter set to On Power Up.

Update the Controller

The controller is shipped without firmware. Controller firmware is packaged with the Studio 5000 environment. In addition, controller firmware is also available for download from the Rockwell Automation® Technical Support website at: <http://www.rockwellautomation.com/support/>.

You can update your firmware by using either ControlFLASH™ software or by using the AutoFlash feature of the Logix Designer application.

Use ControlFLASH Software to Update Firmware

IMPORTANT If the memory card is locked and the Load Image option of the stored project is set to On power-up, the controller firmware does not update. Any previously stored firmware and projects are loaded instead.

- Verify that the appropriate network connection is made and the network driver has been configured in RSLinx software.
- Start ControlFLASH software.
- Click Next.
- Select the catalog number of the controller and click Next.
- Expand the network until you see the controller.
- Select the controller and click Next.

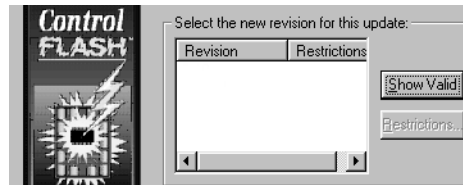

- Select the revision level to which you want to update the controller and click Next.
- To start the update of the controller, click Finish and then click Yes.

After the controller is updated, the status dialog box displays 'Update complete'.

IMPORTANT Allow the firmware update to complete fully before you cycle power or otherwise interrupt the update. If the ControlFLASH update of the controller is interrupted, the controller reverts to boot firmware, which is firmware revision 1.xxx, and you need to repeat the update process.

- Click OK.
- Close the ControlFLASH software.

Use AutoFlash to Update Firmware

To update your controller firmware with the AutoFlash feature, follow these steps.

1. Verify that the appropriate network connection is made and your network driver is configured in RSLinx software.
2. To create a controller project at the version you need, use the Logix Designer application.
3. To specify the controller path, click RSWho.

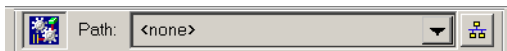

4. Select your controller and click Update Firmware.
5. Select the firmware revision that you want.
6. Click Update.
7. Click Yes.

Allow the firmware update to complete without interruption. When the firmware update is complete, the Who Active dialog box opens. You can complete other tasks in the Logix Designer application.

Create a Controller Project

To create an Armor CompactLogix controller project in the Logix Designer application, you add the 1769-L33ERMO, 1769-L36ERMO, 1769-L37ERMO⁽¹⁾, or 1769-L38ERMO⁽²⁾ controller and the project name to the Controller Organizer as shown.

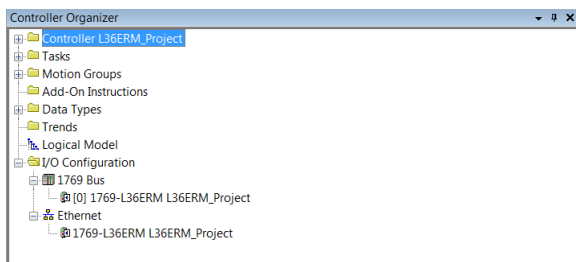

(1) Catalog number 1769-L37ERMO is available at firmware revision 30.

(2) Catalog number 1769-L37ERMO is available at firmware revision 31.

Status Indicators

The graphic shows the controller status indicators for all CompactLogix 5370 controllers.

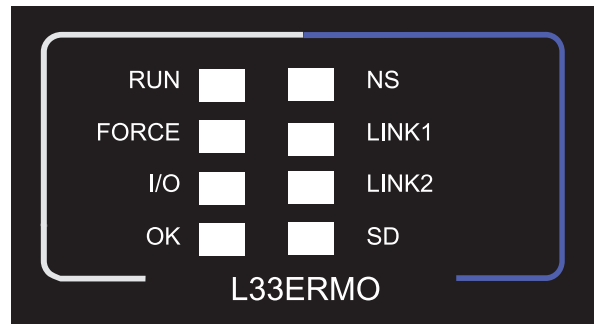

Catalog Number 1769-L33ERMO Controller Shown

Controller Mode (RUN) Status Indicator

Status	Description
Off	The controller is in Program or Test mode.
Green	The controller is in Run mode.

Force State (FORCE) Status Indicator

Status	Description
Off	No tags contain I/O force values. I/O forces are inactive (disabled).
Yellow	I/O forces are active (enabled). I/O force values can exist.
Flashing yellow	One or more input or output addresses have been forced to an On or Off condition, but the forces have not been enabled.

I/O State (I/O) Status Indicator

Status	Description
Off	One of the following conditions exists: <ul style="list-style-type: none"> • There are no devices in the I/O configuration of the controller. Applies to only CompactLogix 5370 L3 controllers. • The controller does not contain a project.
Green	The controller is communicating with all devices in its I/O configuration.
Flashing green	One or more devices in the I/O configuration of the controller are not responding.
Flashing red	One of the following conditions exists: <ul style="list-style-type: none"> • The controller is not communicating with any devices. • A fault has occurred on the controller. Only CompactLogix 5370 L1 and L2 controllers.

Controller Status (OK) Status Indicator

Status	Description
Off	No power is applied.
Green	The controller is OK.
Flashing green	The controller is storing a project to, or loading a project from, the memory card.

Controller Status (OK) Status Indicator

Status	Description
Red	One of the following: <ul style="list-style-type: none"> The controller detected a nonrecoverable major fault and cleared the project from memory. The controller is not ready, or not able, to be powered up.
Flashing red	One of the following: <ul style="list-style-type: none"> The controller requires a firmware update. A major recoverable fault occurred on the controller. A nonrecoverable major fault occurred on the controller and cleared the program from memory. A controller firmware update is in process. An embedded I/O module firmware update is in process. Only CompactLogix 5370 L1 controllers.
Dim green to red	Save to flash at power-down.

Ethernet Network Status (NS) Status Indicator

Status	Description
Off	The port is not initialized; it does not have an IP address and is operating in BOOTP or DHCP mode.
Green	The port has an IP address and CIP connections are established.
Flashing green	The port has an IP address, but no CIP connections are established.
Red	The port has detected that the assigned IP address is in use.
Flashing red/green	The port is performing its power-up self-test.

Ethernet Link Status (LINK 1/LINK 2) Status Indicator

Status	Description
Off	One of the following conditions exists: <ul style="list-style-type: none"> No link. Port administratively disabled. Port is disabled because a rapid ring fault condition was detected (LINK2).
Green	One of the following conditions exists: <ul style="list-style-type: none"> A 100 Mbps link (half- or full-duplex) exists, no activity. A 10 Mbps link (half- or full-duplex) exists, no activity. Ring network is operating normally and the controller is the active supervisor. Ring network has encountered a rare partial network fault and the controller is the active supervisor.
Flashing green	One of the following conditions exists: <ul style="list-style-type: none"> A 100 Mbps link exists and there is activity. A 10 Mbps link exists and there is activity.

Memory Card Activity (SD) Status Indicator

Status	Description
Off	There is no activity to the memory card.
Flashing green	The controller is reading from or writing to the memory card.
Flashing red	The memory card does not have a file system.

Reset the Controller

To clear the user program from internal memory during powerup, follow these steps.

1. Open the access door on the enclosure.
2. Press and hold the reset button while the controller powers up.
3. Close the enclosure access door and torque the four screws to 3.8 N•m (33.5 lb•in).

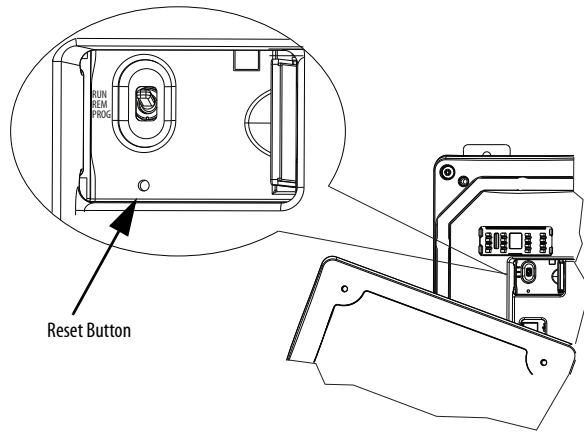

Recover the Controller By Using a Memory Card

If you need to recover the controller, due to a corrupt program or other issue, you can do so by creating a recovery memory card. This procedure requires the use of a second, user-supplied 1784-SD1 memory card. Perform this procedure on a separate controller that is not locked and is not corrupt, or perform the procedure before downloading any project to your Armor CompactLogix controller.

IMPORTANT To avoid inadvertently overwriting your application program, you must not use the 1784-SD1 memory card that was shipped installed in the Armor CompactLogix controller.

To create the recovery memory card, follow these steps.

1. Update the Armor CompactLogix controller to the desired firmware revision by following the instructions in [Update the Controller on page 10](#).
2. Remove the memory card that shipped with the controller by following the instructions in [Remove and Install the Memory Card on page 6](#).
3. Insert a new 1784-SD1 card.

TIP Label this memory card 'recovery', so that you do not confuse it with the memory card that was shipped with the controller.

4. To store the project to the memory card and load on powerup, load a blank project into the controller, and make sure to check the box.
5. Remove the 'recovery' memory card and store it in a secure location.
6. Reinsert the memory card that shipped with the Armor CompactLogix controller by following the instructions in [Remove and Install the Memory Card on page 6](#).

To use the recovery memory card to recover the controller, follow these steps.

1. Remove the memory card that was shipped with the controller.
2. Insert the recovery memory card.
3. Cycle power to the controller.
The blank project on the recovery memory card overwrites the project in the controller.

Replace the Fuse

To replace a blown fuse, follow these steps.

1. Remove power from the controller system.
2. Correct the conditions that caused the fuse to blow.
3. To remove the fuse housing cover, place a slotted screwdriver under the tab.

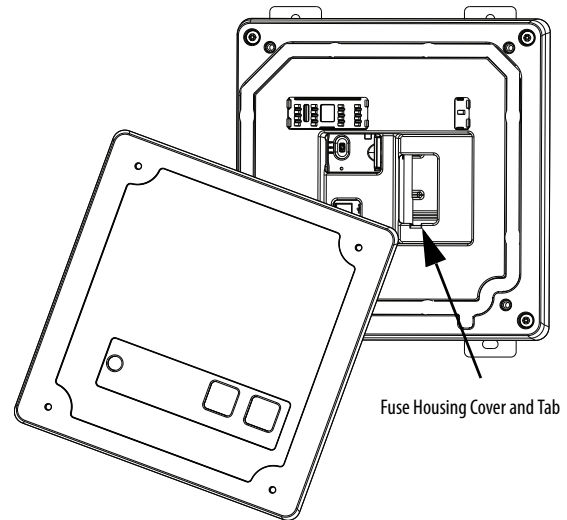

4. Use a fuse puller or similar device to remove the fuse.
Be careful. Do not damage the printed circuit board and surrounding electronics.
5. To replace the front access fuse, center the replacement fuse over the fuse clip and press down.
See Specifications for information on the front access fuse.
If you use a tool to press the fuse in place, apply pressure to only the metal end caps, not to the center of the fuse.
6. Replace the fuse housing cover.
7. Restore power to the controller.

Clean the Controller



ATTENTION: Use only a soft dry anti-static cloth to wipe down equipment. Do not use any cleaning agents.

Specifications

This section lists general specifications specific to the enclosure.

Attribute	1769-L33ERMO, 1769-L36ERMO, 1769-L37ERMO ⁽¹⁾ , 1769-L38ERMO ⁽²⁾
Voltage and current ratings: In (pins 2, 3) In (pins 1, 4) Out (pins 1, 4) Out (pins 2, 3)	18...32V DC, 8 A SELV 18...32V DC, 8 A SELV 18...32V DC, 8 A 18...32V DC, 6 A
Enclosure type rating	Type 4/4x outdoor use. Meets IP67 with receptacle dust caps or cable termination.
Isolation voltage	30V (continuous), Basic Insulation Type, Power to enclosure, Ethernet channels to Power, and non-redundant Ethernet channels to non-redundant Ethernet channels. No isolation between redundant Ethernet channels.
Temperature, operating IEC 60068-2-1 (Test Ad, Operating Cold) IEC 60068-2-2 (Test Bd, Operating Dry Heat) IEC 60068-2-14 (Test Nb, Operating Thermal Shock)	0...60 °C (32...140 °F)
Temperature, ambient max	60 °C (140 °F)
Weight, approx (with mounting feet)	5.40 kg (11.90 lb)
Dimensions (H x W x D), approx (see Product Dimensions, mm (in.) on page 4 for dimensions with mounting feet)	239 x 234 x 155 mm (9.4 x 9.2 x 6.1 in.)

(1) Catalog number 1769-L37ERMO is available at Firmware Revision 30.

(2) Catalog number 1769-L38ERMO is available at Firmware Revision 31.



ATTENTION: This equipment is certified for use only within the ambient air temperature range of 0...60 °C (32...140 °F). The equipment must not be used outside of this range.

Waste Electrical and Electronic Equipment (WEEE)



At the end of its life, this equipment should be collected separately from any unsorted municipal waste.

Notes:

Additional Resources

These documents contain additional information concerning related products from Rockwell Automation.

Resource	Description
CompactLogix Controllers Specifications Technical Data, publication 1769-ID005	Provides CompactLogix controller specifications for all CompactLogix controllers.
CompactLogix 5370 Controllers User Manual, publication 1769-UM021	Provides information on how to install, configure, program, and use CompactLogix 5370 controllers in Studio 5000 projects.
Guidance for Selecting Cables for EtherNet/IP Networks White Paper, publication ENET-WP007 .	Provides information on how to select cables for EtherNet/IP networks.
Industrial Automation Wiring and Grounding Guidelines, publication 1770-4.1	Provides general guidelines for installing a Rockwell Automation industrial system.
Product Certifications website, http://www.rockwellautomation.com/global/certification/overview.page	Provides declarations of conformity, certificates, and other certification details.

You can view or download publications at <http://www.rockwellautomation.com/global/literature-library/overview.page>. To order paper copies of technical documentation, contact your local Allen-Bradley distributor or Rockwell Automation sales representative.

Rockwell Automation Support

Use the following resources to access support information.

Technical Support Center	Knowledgebase Articles, How-to Videos, FAQs, Chat, User Forums, and Product Notification Updates.	https://rockwellautomation.custhelp.com/
Local Technical Support Phone Numbers	Locate the phone number for your country.	http://www.rockwellautomation.com/global/support/get-support-now.page
Direct Dial Codes	Find the Direct Dial Code for your product. Use the code to route your call directly to a technical support engineer.	http://www.rockwellautomation.com/global/support/direct-dial.page
Literature Library	Installation Instructions, Manuals, Brochures, and Technical Data.	http://www.rockwellautomation.com/global/literature-library/overview.page
Product Compatibility and Download Center (PCDC)	Get help determining how products interact, check features and capabilities, and find associated firmware.	http://www.rockwellautomation.com/global/support/pcdc.page

Documentation Feedback

Your comments will help us serve your documentation needs better. If you have any suggestions on how to improve this document, complete the How Are We Doing? form at http://literature.rockwellautomation.com/idc/groups/literature/documents/du/ra-du002_-en-e.pdf.

Rockwell Automation maintains current product environmental information on its website at <http://www.rockwellautomation.com/rockwellautomation/about-us/sustainability-ethics/product-environmental-compliance.page>.

Allen-Bradley, Armor, ArmorStart, CompactLogix, ControlFLASH, ControlLogix, GuardLogix, On-Machine, Rockwell Automation, Rockwell Software, RSLinx, Studio 5000, and Studio 5000 Logix Designer are trademarks of Rockwell Automation, Inc. Trademarks not belonging to Rockwell Automation are property of their respective companies.

Rockwell Otomasyon Ticaret A.Ş., Kar Plaza İş Merkezi E Blok Kat:6 34752 İçerenköy, İstanbul, Tel: +90 (216) 5698400

www.rockwellautomation.com

Power, Control and Information Solutions Headquarters

Americas: Rockwell Automation, 1201 South Second Street, Milwaukee, WI 53204-2496 USA, Tel: (1) 414.382.2000, Fax: (1) 414.382.4444
Europe/Middle East/Africa: Rockwell Automation NV, Pegasus Park, De Kleetlaan 12a, 1831 Diegem, Belgium, Tel: (32) 2 663 0600, Fax: (32) 2 663 0640
Asia Pacific: Rockwell Automation, Level 14, Core F, Cyberport 3, 100 Cyberport Road, Hong Kong, Tel: (852) 2887 4788, Fax: (852) 2508 1846

