



## ControlLogix Data Highway Plus and Remote I/O Scanner Module

Catalog Numbers 1756-DHRIO, 1756-DHRIOK, 1756-DHRIOXT, 1756-RIO, 1756-RIOK

Topic	Page
Install the Module	5
Connect the DH+ and Remote I/O Channels (1756-DHRIO, 1756-DHRIOK, 1756ODHRIOXT)	6
Connect Remote I/O Channels (1756-RIO, 1756-RIOK)	7
Network Connector and Cable	7
Specifications	8
Additional Resources	8

The ControlLogix® Data Highway Plus™ and remote I/O scanner module sends messages between ControlLogix controllers, PLC, and SLC™ controllers in DH+™ applications.

### Summary of Changes

This publication contains new and updated information as indicated in the following table.

Topic	Page
Added Plug Attention Statement	7
Specifications	8



**ATTENTION:** Read this document and the documents listed in the Additional Resources section about installation, configuration and operation of this equipment before you install, configure, operate or maintain this product. Users are required to familiarize themselves with installation and wiring instructions in addition to requirements of all applicable codes, laws, and standards.

Activities including installation, adjustments, putting into service, use, assembly, disassembly, and maintenance are required to be carried out by suitably trained personnel in accordance with applicable code of practice. If this equipment is used in a manner not specified by the manufacturer, the protection provided by the equipment may be impaired.

**注意:** 在安装、配置、操作和维护本产品前, 请阅读本文档以及“其他资源”部分列出的有关设备安装、配置和操作的相应文档。除了所有适用规范、法律和标准的相关要求之外, 用户还必须熟悉安装和接线说明。

安装、调整、投运、使用、组装、拆卸和维护等各项操作必须由经过适当训练的专业人员按照适用的操作规范实施。

如果未按照制造商指定的方式使用该设备, 则可能会损害设备提供的保护。

**ATENCIÓN:** Antes de instalar, configurar, poner en funcionamiento o realizar el mantenimiento de este producto, lea este documento y los documentos listados en la sección Recursos adicionales acerca de la instalación, configuración y operación de este equipo. Los usuarios deben familiarizarse con las instrucciones de instalación y cableado y con los requisitos de todos los códigos, leyes y estándares vigentes.

El personal debidamente capacitado debe realizar las actividades relacionadas a la instalación, ajustes, puesta en servicio, uso, ensamblaje, desensamblaje y mantenimiento de conformidad con el código de práctica aplicable. Si este equipo se usa de una manera no especificada por el fabricante, la protección provista por el equipo puede resultar afectada.

**ATENÇÃO:** Leia este e os demais documentos sobre instalação, configuração e operação do equipamento que estão na seção Recursos adicionais antes de instalar, configurar, operar ou manter este produto. Os usuários devem se familiarizar com as instruções de instalação e fiação além das especificações para todos os códigos, leis e normas aplicáveis.

É necessário que as atividades, incluindo instalação, ajustes, colocação em serviço, utilização, montagem, desmontagem e manutenção sejam realizadas por pessoal qualificado e especializado, de acordo com o código de prática aplicável.

Caso este equipamento seja utilizado de maneira não estabelecida pelo fabricante, a proteção fornecida pelo equipamento pode ficar prejudicada.

**ВНИМАНИЕ:** Перед тем как устанавливать, настраивать, эксплуатировать или обслуживать данное оборудование, прочитайте этот документ и документы, перечисленные в разделе «Дополнительные ресурсы». В этих документах изложены сведения об установке, настройке и эксплуатации данного оборудования. Пользователи обязаны ознакомиться с инструкциями по установке и прокладке соединений, а также с требованиями всех применимых норм, законов и стандартов.

Все действия, включая установку, наладку, ввод в эксплуатацию, использование, сборку, разборку и техническое обслуживание, должны выполняться обученным персоналом в соответствии с применимыми нормами и правилами.

Если оборудование используется не предусмотренным производителем образом, защита оборудования может быть нарушена.

**注意:** 本製品を設置、構成、稼働または保守する前に、本書および本機器の設置、設定、操作についての参考資料の該当箇所に記載されている文書に目を通してください。ユーザは、すべての該当する条例、法律、規格の要件に加えて、設置および配線の手順に習熟している必要があります。

設置調整、運転の開始、使用、組立て、解体、保守を含む諸作業は、該当する実施規則に従って訓練を受けた適切な作業員が実行する必要があります。

本機器が製造メーカーにより指定されていない方法で使用される場合、機器により提供されている保護が損なわれる恐れがあります。

**ACHTUNG:** Lesen Sie dieses Dokument und die im Abschnitt „Weitere Informationen“ aufgeführten Dokumente, die Informationen zu Installation, Konfiguration und Bedienung dieses Produkts enthalten, bevor Sie dieses Produkt installieren, konfigurieren, bedienen oder warten. Anwender müssen sich neben den Bestimmungen aller anwendbaren Vorschriften, Gesetze und Normen zusätzlich mit den Installations- und Verdrahtungsanweisungen vertraut machen.

Arbeiten im Rahmen der Installation, Anpassung, Inbetriebnahme, Verwendung, Montage, Demontage oder Instandhaltung dürfen nur durch ausreichend geschulte Mitarbeiter und in Übereinstimmung mit den anwendbaren Ausführungsanweisungen vorgenommen werden.

Wenn das Gerät in einer Weise verwendet wird, die vom Hersteller nicht vorgesehen ist, kann die Schutzfunktion beeinträchtigt sein.

**ATTENTION:** Lisez ce document et les documents listés dans la section Ressources complémentaires relatifs à l'installation, la configuration et le fonctionnement de cet équipement avant d'installer, configurer, utiliser ou entretenir ce produit. Les utilisateurs doivent se familiariser avec les instructions d'installation et de câblage en plus des exigences relatives aux codes, lois et normes en vigueur.

Les activités relatives à l'installation, le réglage, la mise en service, l'utilisation, l'assemblage, le démontage et l'entretien doivent être réalisées par des personnes formées selon le code de pratique en vigueur.

Si cet équipement est utilisé d'une façon qui n'a pas été définie par le fabricant, la protection fournie par l'équipement peut être compromise.

**주의:** 본 제품 설치, 설정, 작동 또는 유지 보수하기 전에 본 문서를 포함하여 설치, 설정 및 작동에 관한 참고 자료 섹션의 문서들을 반드시 읽고 숙지하십시오. 사용자는 모든 관련 규정, 법규 및 표준에서 요구하는 사항에 대해 반드시 설치 및 배선 지침을 숙지해야 합니다.

설치, 조정, 가동, 사용, 조립, 분해, 유지보수 등 모든 작업은 관련 규정에 따라 적절한 교육을 받은 사용자를 통해서만 수행해야 합니다.

본 장비를 제조사가 명시하지 않은 방법으로 사용하면 장비의 보호 기능이 손상될 수 있습니다.

**ATTENZIONE** Prima di installare, configurare ed utilizzare il prodotto, o effettuare interventi di manutenzione su di esso, leggere il presente documento ed i documenti elencati nella sezione "Altre risorse", riguardanti l'installazione, la configurazione ed il funzionamento dell'apparecchiatura. Gli utenti devono leggere e comprendere le istruzioni di installazione e cablaggio, oltre ai requisiti previsti dalle leggi, codici e standard applicabili.

Le attività come installazione, regolazioni, utilizzo, assemblaggio, disassemblaggio e manutenzione devono essere svolte da personale adeguatamente addestrato, nel rispetto delle procedure previste.

Qualora l'apparecchio venga utilizzato con modalità diverse da quanto previsto dal produttore, la sua funzione di protezione potrebbe venire compromessa.

**DİKKAT:** Bu ürünün kurulumu, yapılandırılması, işletilmesi veya bakımı öncesinde bu dokümanı ve bu ekipmanın kurulumu, yapılandırılması ve işletimi ile ilgili ilave Kaynaklar bölümünde yer listelenmiş dokümanları okuyun. Kullanıcılar yürürlükteki tüm yönetmelikler, yasalar ve standartların gereksinimlerine ek olarak kurulum ve kablolama talimatlarını da öğrenmek zorundadır. Kurulum, ayarlama, hizmete alma, kullanma, parçaları birleştirme, parçaları sökme ve bakım gibi aktiviteler sadece uygun eğitimleri almış kişiler tarafından yürürlükteki uygulama yönetmeliklerine uygun şekilde yapılabilir.

Bu ekipman üretici tarafından belirlenmiş amacın dışında kullanılırsa, ekipman tarafından sağlanan koruma bozulabilir.

**注意事項:** 在安装、設定、操作或維護本产品前, 請先閱讀此文件以及列於「其他資源」章節中有關安裝、設定與操作此設備的文件。使用者必須熟悉安裝和配線指示, 並符合所有法規、法律和標準要求。

包括安裝、調整、交付使用、使用、組裝、拆卸和維護等動作都必須交由已經適當訓練的人員進行, 以符合適用的實作法規。

如果將設備用於非製造商指定的用途時, 可能會造成設備所提供的保護功能受損。

**POZOR:** Než začnete instalovat, konfigurovat či provozovat tento výrobek nebo provádět jeho údržbu, přečtěte si tento dokument a dokumenty uvedené v části Dodatečné zdroje ohledně instalace, konfigurace a provozu tohoto zařízení. Uživatelé se musejí vedle požadavků všech relevantních vyhlášek, zákonů a norem nutně seznámit také s pokyny pro instalaci a elektrické zapojení.

Činnosti zahrnující instalaci, nastavení, uvedení do provozu, užívání, montáž, demontáž a údržbu musí vykonávat vhodné proškolený personál v souladu s příslušnými prováděcími předpisy. Pokud se toto zařízení používá způsobem neodpovídajícím specifikaci výrobce, může být narušena ochrana, kterou toto zařízení poskytuje.

**UWAGA:** Przed instalacją, konfiguracją, użytkowaniem lub konserwacją tego produktu należy przeczytać niniejszy dokument oraz wszystkie dokumenty wymienione w sekcji Dodatkowe źródła omawiające instalację, konfigurację i procedury użytkowania tego urządzenia. Użytkownicy mają obowiązek zapoznać się z instrukcjami dotyczącymi instalacji oraz oprzewodowania, jak również z obowiązującymi kodeksami, prawem i normami.

Działania obejmujące instalację, regulację, przekazanie do użytkowania, użytkowanie, montaż, demontaż oraz konserwację muszą być wykonywane przez odpowiednio przeszkolony personel zgodnie z obowiązującym kodeksem postępowania.

Jeśli urządzenie jest użytkowane w sposób inny niż określony przez producenta, zabezpieczenie zapewniane przez urządzenie może zostać ograniczone.

**Obs:** Läs detta dokument samt dokumentet, som står listat i avsnittet Övriga resurser, om installation, konfigurering och drift av denna utrustning innan du installerar, konfigurerar eller börjar använda eller utföra underhållsarbete på produkten. Användare måste bekanta sig med instruktioner för installation och kabeldragning, förutom krav enligt gällande koder, lagar och standarder.

Åtgärder som installation, justering, service, användning, montering, demontering och underhållsarbete måste utföras av personal med lämplig utbildning enligt lämpligt bruk.



Om denna utrustning används på ett sätt som inte anges av tillverkaren kan det hända att utrustningens skyddsanordningar försätts ur funktion.

**LET OP:** Lees dit document en de documenten die genoemd worden in de paragraaf Aanvullende informatie over de installatie, configuratie en bediening van deze apparatuur voordat u dit product installeert, configureert, bedient of onderhoudt. Gebruikers moeten zich vertrouwd maken met de installatie en de bedravingsinstructies, naast de vereisten van alle toepasselijke regels, wetten en normen.

Activiteiten zoals het installeren, afstellen, in gebruik stellen, gebruiken, monteren, demonteren en het uitvoeren van onderhoud mogen uitsluitend worden uitgevoerd door hiervoor opgeleid personeel en in overeenstemming met de geldende praktijkregels.

Indien de apparatuur wordt gebruikt op een wijze die niet is gespecificeerd door de fabrikant, dan bestaat het gevaar dat de beveiliging van de apparatuur niet goed werkt.

**North American Hazardous Location Approval**

The following information applies when operating this equipment in hazardous locations.	Informations sur l'utilisation de cet équipement en environnements dangereux.
<p>Products marked "CL I, DIV 2, GP A, B, C, D" are suitable for use in Class I Division 2 Groups A, B, C, D, Hazardous Locations and nonhazardous locations only. Each product is supplied with markings on the rating nameplate indicating the hazardous location temperature code. When combining products within a system, the most adverse temperature code (lowest "T" number) may be used to help determine the overall temperature code of the system. Combinations of equipment in your system are subject to investigation by the local Authority Having Jurisdiction at the time of installation.</p>	<p>Les produits marqués "CL I, DIV 2, GP A, B, C, D" ne conviennent qu'à une utilisation en environnements de Classe I Division 2 Groupes A, B, C, D dangereux et non dangereux. Chaque produit est livré avec des marquages sur sa plaque d'identification qui indiquent le code de température pour les environnements dangereux. Lorsque plusieurs produits sont combinés dans un système, le code de température le plus défavorable (code de température le plus faible) peut être utilisé pour déterminer le code de température global du système. Les combinaisons d'équipements dans le système sont sujettes à inspection par les autorités locales qualifiées au moment de l'installation.</p>
<div style="display: flex; align-items: center;">  <div> <p><b>WARNING:</b> <b>Explosion Hazard -</b></p> <ul style="list-style-type: none"> <li>• Do not disconnect equipment unless power has been removed or the area is known to be nonhazardous.</li> <li>• Do not disconnect connections to this equipment unless power has been removed or the area is known to be nonhazardous. Secure any external connections that mate to this equipment by using screws, sliding latches, threaded connectors, or other means provided with this product.</li> <li>• Substitution of components may impair suitability for Class I, Division 2.</li> <li>• If this product contains batteries, they must only be changed in an area known to be nonhazardous.</li> </ul> </div> </div>	<div style="display: flex; align-items: center;">  <div> <p><b>AVERTISSEMENT:</b> <b>Risque d'Explosion -</b></p> <ul style="list-style-type: none"> <li>• Couper le courant ou s'assurer que l'environnement est classé non dangereux avant de débrancher l'équipement.</li> <li>• Couper le courant ou s'assurer que l'environnement est classé non dangereux avant de débrancher les connecteurs. Fixer tous les connecteurs externes reliés à cet équipement à l'aide de vis, loquets coulissants, connecteurs filetés ou autres moyens fournis avec ce produit.</li> <li>• La substitution de composants peut rendre cet équipement inadapté à une utilisation en environnement de Classe I, Division 2.</li> <li>• S'assurer que l'environnement est classé non dangereux avant de changer les piles.</li> </ul> </div> </div>

**European Hazardous Location Approval<sup>(1)</sup>**

The following applies to products marked **CE**  II 3 G. Such modules:

- Are Equipment Group II, Equipment Category 3, and comply with the Essential Health and Safety Requirements relating to the design and construction of such equipment that is given in Annex II to Directive 2014/34/EU. See the EC Declaration of Conformity at <http://www.rockwellautomation.com/products/certification> for details.
- The type of protection is "Ex nA IIC T4 Gc" according to EN 60079-15.
- Comply to Standards EN 60079-0:2012, EN 60079-15:2010, reference certificate number LCIE01ATEX6020X<sup>(2)</sup> and reference certificate number DEMK013ATEX1325026X<sup>(3)</sup>.
- Are intended for use in areas in which explosive atmospheres caused by gases, vapors, mists, or air are unlikely to occur, or are likely to occur only infrequently and for short periods. Such locations correspond to Zone 2 classification according to ATEX directive 2014/34/EU.
- May have catalog numbers followed by a "K" to indicate a conformal coating option.

(1) 1756-RIO/K has no European Hazardous Location Approval.

(2) 1756-DHRIO/K

(3) 1756-DHRIOXT

	<p><b>WARNING:</b> Special Conditions for Safe Use<sup>(1)</sup>:</p> <ul style="list-style-type: none"> <li>• This equipment shall be mounted in an ATEX Zone 2 certified enclosure with a minimum ingress protection rating of at least IP54 (in accordance with EN 60079-15) and used in an environment of not more than Pollution Degree 2 (as defined in EN 60664-1) when applied in Zone 2 environments. The enclosure must be accessible only by the use of a tool.</li> <li>• This equipment shall be used within its specified ratings defined by Rockwell Automation.</li> <li>• Provision shall be made to prevent the rated voltage from being exceeded by transient disturbances of more than 140% of the peak rated voltage when applied in Zone 2 environments.</li> <li>• The instructions in the user manual shall be observed.</li> <li>• This equipment must be used only with ATEX certified Rockwell Automation backplanes.</li> <li>• Secure any external connections that mate to this equipment by using screws, sliding latches, threaded connectors, or other means provided with this product.</li> <li>• Do not disconnect equipment unless power has been removed or the area is known to be nonhazardous.</li> </ul>
---	--

(1) Not applicable to 1756-RIO/K.

**IMPORTANT**

Any illustrations, charts, sample programs, and layout examples that are shown in this publication are intended solely for the purposes of example. Since there are many variables and requirements that are associated with any particular installation, Rockwell Automation does not assume responsibility or liability for actual use based upon the examples shown in this publication.

	<p><b>WARNING:</b> When you insert or remove the module while backplane power is on, an electric arc can occur. This could cause an explosion in hazardous location installations. Be sure that power is removed or the area is nonhazardous before proceeding. Repeated electrical arcing causes excessive wear to contacts on both the module and its mating connector. Worn contacts may create electrical resistance that can affect module operation.</p>
---	--



**WARNING:** The local programming terminal port is intended for temporary use only and must not be connected or disconnected unless the area is confirmed to be nonhazardous.  
For hazardous locations, use the following Rockwell Automation cable for the programming terminal connection: 1784-U2DHP

---



**ATTENTION:** This equipment is sensitive to electrostatic discharge, which can cause internal damage and affect normal operation. Follow these guidelines when you handle this equipment:

- Touch a grounded object to discharge potential static.
- Wear an approved grounding wriststrap.
- Do not touch connectors or pins on component boards.
- Do not touch circuit components inside the equipment.
- Use a static-safe workstation, if available.
- Store the equipment in appropriate static-safe packaging when not in use.

---



**ATTENTION:** This equipment is intended for use in a Pollution Degree 2 industrial environment, in overvoltage Category II applications (as defined in IEC 60664-1), at altitudes up to 2000 m (6562 ft) without derating.  
This equipment is not intended for use in residential environments and may not provide adequate protection to radio communication services in such environments.

This equipment is supplied as open-type equipment for indoor use. It must be mounted within an enclosure that is suitably designed for those specific environmental conditions that will be present and appropriately designed to prevent personal injury resulting from accessibility to live parts. The enclosure must have suitable flame-retardant properties to prevent or minimize the spread of flame, complying with a flame spread rating of 5VA or be approved for the application if non-metallic. The interior of the enclosure must be accessible only by the use of a tool. Subsequent sections of this publication may contain more information regarding specific enclosure type ratings that are required to comply with certain product safety certifications.

In addition to this publication, see the following:

- Industrial Automation Wiring and Grounding Guidelines, publication [1770-4.1](#), for additional installation requirements.
  - NEMA 250 and IEC 60529, as applicable, for explanations of the degrees of protection provided by different types of enclosures.
- 



**WARNING:** If you connect or disconnect the communications cable with power applied to this module or any device on the network, an electric arc can occur. This could cause an explosion in hazardous location installations.  
Be sure that power is removed or the area is nonhazardous before proceeding.

---



**ATTENTION:** Read this document and the documents that are listed in the Additional Resources section about installation, configuration, and operation of this equipment before you install, configure, operate, or maintain this product. Users are required to familiarize themselves with installation and wiring instructions in addition to requirements of all applicable codes, laws, and standards.

- Installation, adjustments, putting into service, use, assembly, disassembly, and maintenance are required to be carried out by suitably trained personnel in accordance with applicable code of practice.
- In case of malfunction or damage, no attempts at repair should be made. The module should be returned to the manufacturer for repair. Do not dismantle the module.
- 1756-DHRIO, 1756-DHRIOK, 1756-RIO, and 1756-RIOK are certified for use only within the surrounding air temperature range of 0...60 °C (32...140 °F). The equipment must not be used outside of this range.
- 1756-DHRIOXT is certified for use only within the surrounding air temperature range of -25...70 °C (-13...158 °F). The equipment must not be used outside of this range.
- Use only a soft dry anti-static cloth to wipe down equipment. Do not use any cleaning agents.

---

## Install the Module

You can install or remove the module while chassis power is applied. Follow these steps to install the module.

1. Identify the module features, as shown in the following figure

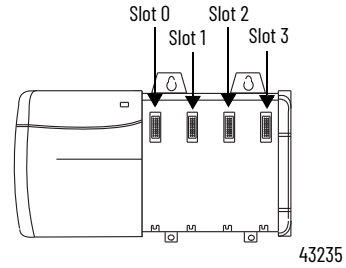
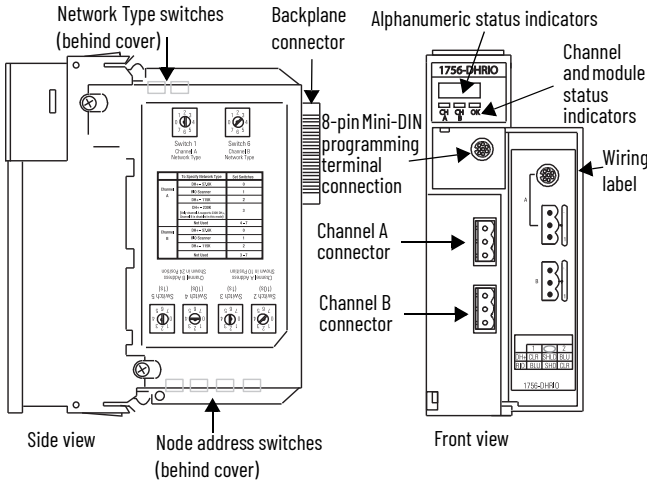

You can use multiple DHRIOXT modules in the same chassis.

5. Follow these steps to install the module.
  - a. Align the circuit board with the top and bottom guides in the chassis.
  - b. Slide the module into the chassis.
  - c. Make sure that the module backplane connector properly connects to the chassis backplane.

2. Install and connect a ControlLogix chassis and power supply.

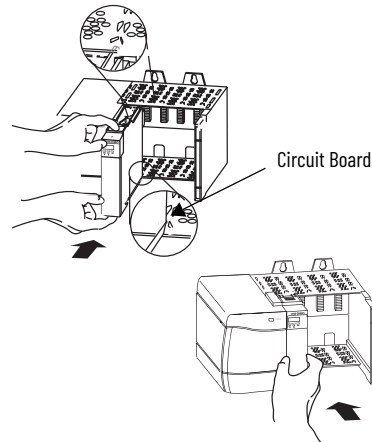
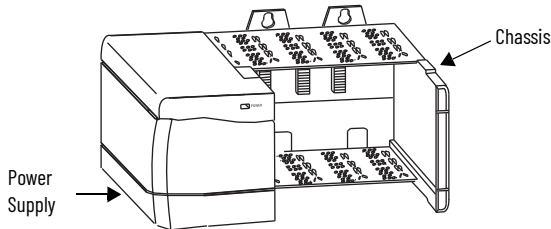

3. Select the network type switches for each channel. If your network type is DH+, you must also set the node address switches for that channel.

**IMPORTANT** If you are using the Remote I/O network, do not set node address switches.

For each channel, you can select a node address within the range of 00...77.

4. Determine module slot location.

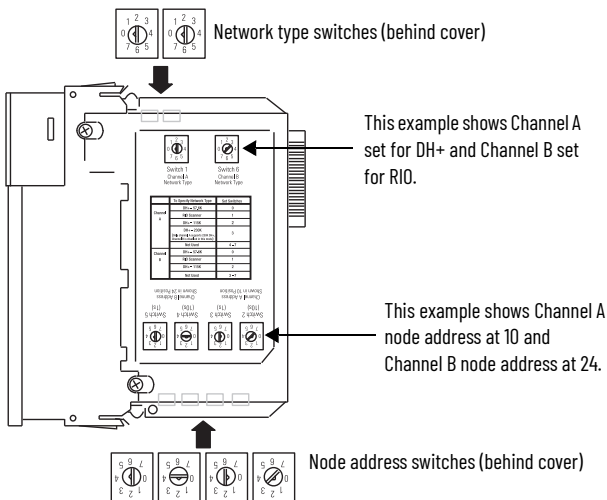

If you are replacing an existing module with an identical one, and you want to resume identical system operation, you must install the new module in the same slot.

6. Wire the connectors for the Module Channels per the following table and figure.

**Pin Assignments for Channel A and B Connectors**

DH+		Remote I/O	
Pin no.:	Description:	Pin no.:	Description:
1	Clear	1	Blue
	Shield		Shield
2	Blue	2	Clear

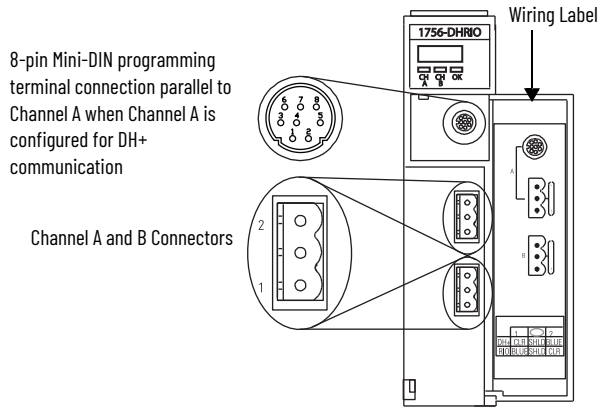

7. Connect the module to the programming terminal and Data Highway Plus or Remote I/O network.

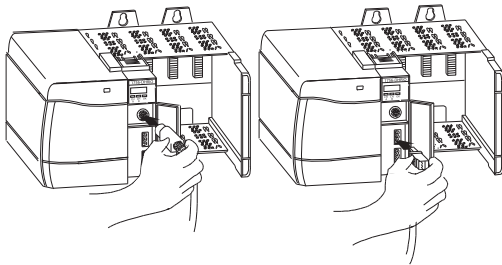

- 8. Apply chassis power.
- 9. Check power supply and module status. See the following figure and table for further information.

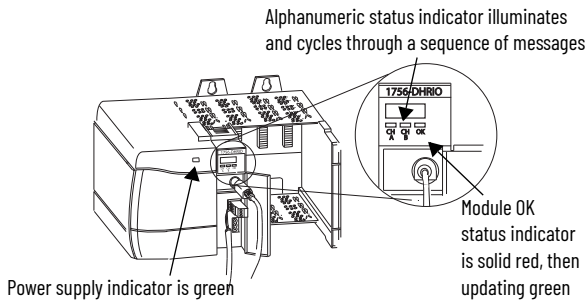

**Data Highway Plus**

Sequence of Display	Where
A DH A#xx xxxx	A is the channel (A or B) and DH indicates that network type is DH+. xx is the channel node address. xxxx is the channel status message.

**Remote I/O**

Sequence of Display	Where
BIO SCAN xxxx	B is the channel (A or B) and I/O indicates that network type is Remote I/O. SCAN indicates scanner. xxxx is the channel status message.

If after powerup, the alphanumeric indicator does not start cycling (or if it stops cycling) through these messages, refer to the Troubleshooting the Module chapter of the ControlLogix Data Highway Plus-Remote I/O Communication Interface User Manual, publication [1756-UM514](#).

## Connect the DH+ and Remote I/O Channels (1756-DHRIO, 1756-DHRIOK, 17560DHRIOXT)

### Wire the Connectors for the Module Channels

8-pin mini DIN programming terminal connection parallel to channel A when channel A is configured for DH+ communication.

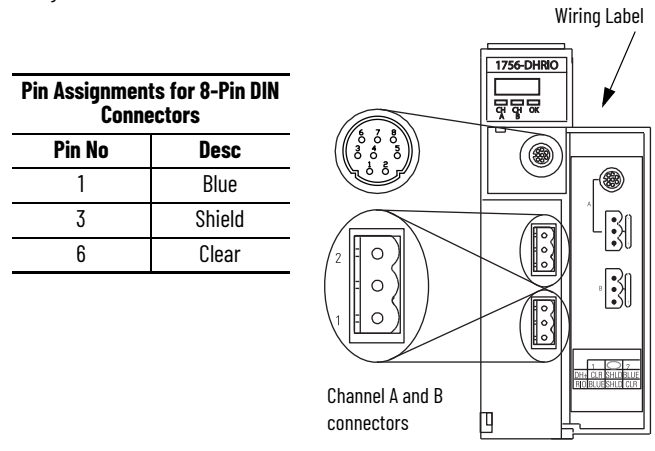

Pin No	Desc
1	Blue
3	Shield
6	Clear

### Pin Assignments for Channel A and B Connectors

DH+		Remote I/O	
Pin No	Desc	Pin No	Desc
1	Clear	1	Blue
	Shield		Shield
2	Blue	2	Clear

## Data Highway +/-Remote I/O Communications Connections



**WARNING:** The local programming terminal port is intended for temporary use only and must not be connected or disconnected unless the area is confirmed to be nonhazardous. If you connect or disconnect the communications connector with power that is applied to this module or any device on the network, an electric arc can occur. This could cause an explosion in hazardous location installations.

Be sure that power is removed or the area is nonhazardous before proceeding.

### Connect the Programming Terminal and DH+ or Remote I/O Network

1. Connect the programming terminal to the 8-pin mini DIN connector.
2. Connect the DH+ or Remote I/O network to the channel A or B connector as appropriate.

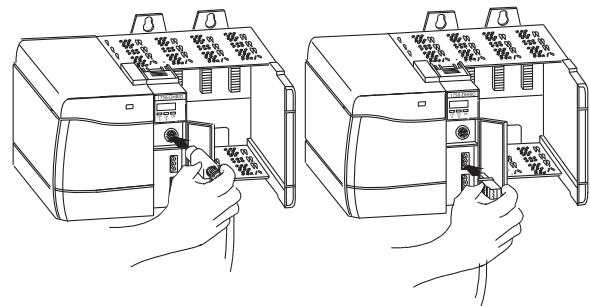

## Connect Remote I/O Channels (1756-RIO, 1756-RIOK)

To wire the connector for the remote I/O network, refer to the Cabling and Termination table and follow these steps.

### Cabling and Termination

Connector Pin	Description
1 (bottom)	Line 1 (blue)
N/A	Shield
2	Line 2 (clear)

1. Connect Line 1 (blue) of the remote I/O cable to the lower pin on the 1756-RIO, 1756-RIOK module.
2. Connect the shield to the middle pin.
3. Connect Line 2 (clear) of the remote I/O cable to the upper pin on the 1756-RIO, 1756-RIOK module.
4. Terminate both ends of a remote I/O network by using external resistors that are attached to the physical ends of the network.

There should be two terminators at the ends network. The terminator is connected between Line 1 (blue) and line 2 (clear).

### Select the Proper Resistor

Use 82  $\Omega$  resistors if the network operates at 230.4 Kbps or if the network operates at 57.6 Kbps, or 115.2 Kbps and none of the devices in this table are present. The maximum number of devices on the network is 32.

Use 150  $\Omega$  resistors if the network contains any of the devices in this table, or if the network operates at 57.6 Kbps or 115.2 Kbps and you do not require the network to support more than 16 devices.

### Device Resistors

Cat. No.	Series
1747-ASB	All
1771-AS	All
1771-ASB	Series A
1775-S5	All
1794-ASB	All
1771-DCM	All
1771-SN	All
1772-SD	All
1772-SD2	All
1775-S4A	All
1775-S4B	All
1775-SR5	All

### Communication Rate Cable Limits

Communication Rate	Maximum Cable Length
57.6 Kbaud	3048 m (10000 ft)
115.2 Kbaud	1524 m (5000 ft)
230.4 Kbaud	762 m (2500 ft)

## Network Connector and Cable

Ports	Catalog Number	Requirements
DH-RIO/DH+	1756-DHRIOXT, 1756-DHRIO, 1756-DHRIOK	Belden 89463 twinaxial, 0.52 mm <sup>2</sup> (20 AWG) rated at 200 °C (392 °F). Connector: Phoenix MVSTBR2.5/3-ST BK AU. Torque: 0.56...0.79 N•m (5...7 lb•in)
RIO	1756-RIO, 1756-RIOK	Belden 9463 copper twinaxial, 0.519 mm <sup>2</sup> (20 AWG) rated at 75 °C (167 °F). Connector: DHRIO. Torque: 0.56...0.79 N•m (5...7 lb•in)
Programming	Nonhazardous locations	1784-CP
	Hazardous locations	1784-U2DHP



**ATTENTION:** The modules that are listed on [page 1](#) of this document that end with a 'K' or 'XT' are shipped with port protection plugs installed to provide a layer of protection from corrosive atmospheres. Port plugs must remain installed in unused ports at all times during storage and operation for the product to meet its corrosive atmosphere rating. If temporary access is required, plugs can be removed, and should be reinserted after temporary access is complete.

## Specifications

Attribute	1756-RIO, 1756-RIOK	1756-DHRIO, 1756-DHRIOK	1756-DHRIOXT
Temperature, operating IEC 60068-2-1 (Test Ad, Operating Cold), IEC 60068-2-2 (Test Bd, Operating Dry Heat), IEC 60068-2-14 (Test Nb, Operating Thermal Shock)	0...60 °C (32...140 °F)		-25...70 °C (-13...158 °F)
Temperature, surrounding air, max	60 °C (140 °F)		70 °C (158 °F)
Corrosive Atmosphere <sup>(1)</sup> • ASTM B845-97 Method H Accelerated Test (20-Day Exposure)	Severity Level G3 <sup>(2)</sup> per ANSI/ISA 71.04-2013, Airborne Contaminants—Gases Severity Level CX <sup>(2)(3)</sup> per IEC 60721-3-3:2019, Chemically Active Substances		
Isolation voltage	50V (continuous), basic insulation type, RIO communications lines to backplane Type tested at 500V AC for 60 s	30V (continuous), basic insulation type, DHRIO A/B to backplane, and DHRIO A/programming port to DHRIO B No isolation between DHRIO A and programming port Type tested at 880V DC for 60 s	30V (continuous), basic insulation type, DHRIO A/B to backplane, and DHRIO A/programming port to DHRIO B No isolation between DHRIO A and programming port Type tested at 860V AC for 60 s
Wire size	0.519 mm <sup>2</sup> (20 AWG) Belden 9463 copper twinaxial		
Terminal block torque	DHRIO connector: 0.56...0.79 N•m (5...7 lb•in)		
Enclosure type rating	None (open-style)		
North American temp code	T4A		
ATEX temp code	-	T4	
IECEx temp code	-	-	T4

(1) Only applicable to modules that end with a 'K' or 'XT'.

(2) Port Plugs must remain installed in unused ports at all times during storage and operation for the product to meet its corrosive atmosphere rating.

(3) Up to 9.6 microns per year, corrosion rate of copper.

## Additional Resources

These documents contain additional information concerning related products from Rockwell Automation.

Resource	Description
ControlLogix Data Highway Plus-Remote I/O Communication Interface User Manual, publication <a href="#">1756-UM514</a>	Describes how to configure and use 1756-DHRIOXT modules.
ControlLogix Remote I/O Communication Module User Manual, publication <a href="#">1756-UM534</a>	Describes how to configure and troubleshoot your Logix Remote I/O (RIO) Communication Module.
Industrial Automation Wiring and Grounding Guidelines, publication <a href="#">1770-4.1</a>	Provides general guidelines for installing a Rockwell Automation industrial system.
Product Certifications website, <a href="http://rok.auto/certifications">rok.auto/certifications</a>	Provides declarations of conformity, certificates, and other certification details.

You can view or download publications at [rok.auto/literature](http://rok.auto/literature).

**Notes:**

# Rockwell Automation Support

Use these resources to access support information.

<b>Technical Support Center</b>	Find help with how-to videos, FAQs, chat, user forums, and product notification updates.	<a href="http://rok.auto/support">rok.auto/support</a>
<b>Knowledgebase</b>	Access Knowledgebase articles.	<a href="http://rok.auto/knowledgebase">rok.auto/knowledgebase</a>
<b>Local Technical Support Phone Numbers</b>	Locate the telephone number for your country.	<a href="http://rok.auto/phonesupport">rok.auto/phonesupport</a>
<b>Literature Library</b>	Find installation instructions, manuals, brochures, and technical data publications.	<a href="http://rok.auto/literature">rok.auto/literature</a>
<b>Product Compatibility and Download Center (PCDC)</b>	Download firmware, associated files (such as AOP, EDS, and DTM), and access product release notes.	<a href="http://rok.auto/pcdc">rok.auto/pcdc</a>

## Documentation Feedback

Your comments help us serve your documentation needs better. If you have any suggestions on how to improve our content, complete the form at [rok.auto/docfeedback](http://rok.auto/docfeedback).

## Waste Electrical and Electronic Equipment (WEEE)







At the end of life, this equipment should be collected separately from any unsorted municipal waste.

Rockwell Automation maintains current product environmental compliance information on its website at [rok.auto/pec](http://rok.auto/pec).

Your comments help us serve your documentation needs better. If you have any suggestions on how to improve our content, complete the form at [rok.auto/docfeedback](http://rok.auto/docfeedback).

For technical support, visit [rok.auto/support](http://rok.auto/support).

Rockwell Otomasyon Ticaret A.Ş. Kar Plaza İş Merkezi E Blok Kat:6 34752 İçerenköy, İstanbul, Tel: +90 (216) 5698400 EEE Yönetmeliğine Uygundur

Connect with us.    

**rockwellautomation.com** — expanding human possibility™

AMERICAS: Rockwell Automation, 1201 South Second Street, Milwaukee, WI 53204-2496 USA, Tel: (1) 414.382.2000, Fax: (1) 414.382.4444

EUROPE/MIDDLE EAST/AFRICA: Rockwell Automation NV, Pegasus Park, De Kleetlaan 12a, 1831 Diegem, Belgium, Tel: (32) 2 663 0600, Fax: (32) 2 663 0640

ASIA PACIFIC: Rockwell Automation, Level 14, Core F, Cyberport 3, 100 Cyberport Road, Hong Kong, Tel: (852) 2887 4788, Fax: (852) 2508 1846

Allen-Bradley, ControlLogix, Data Highway Plus, DH+, expanding human possibility, Rockwell Automation, and SLC are trademarks of Rockwell Automation, Inc. Trademarks not belonging to Rockwell Automation are property of their respective companies.

Publication 1756-IN070B-EN-P - June 2021 | Supersedes Publication 1756-IN070A-EN-P-September 2017  
Copyright © 2021 Rockwell Automation, Inc. All rights reserved. Printed in the U.S.A.

PN-631230