

## ControlLogix 5580 Controllers

Standard Catalog Numbers:	1756-L81E, 1756-L82E, 1756-L83E, 1756-L84E, 1756-L85E
No Stored Energy (NSE) Catalog Numbers:	1756-L81E-NSE, 1756-L82E-NSE, 1756-L83E-NSE, 1756-L84E-NSE, 1756-L85E-NSE, 1756-L81E-NSEXT, 1756-L82E-NSEXT, 1756-L83E-NSEXT, 1756-L84E-NSEXT, 1756-L85E-NSEXT
Process Catalog Numbers:	1756-L81EP, 1756-L83EP, 1756-L85EP, 1756-L81EPXT, 1756-L83EPXT, 1756-L85EPXT
Harsh Environment Catalog Numbers:	1756-L81EK, 1756-L82EK, 1756-L83EK, 1756-L84EK, 1756-L85EK, 1756-L81EXT, 1756-L82EXT, 1756-L83EXT, 1756-L84EXT, 1756-L85EXT

Topic	Page
Summary of Changes	2
Product Advisories	3
Parts List	5
Required System Components	5
Product Dimensions	5
Connectors and Status Indicators	6
Install the Controller	6
Insert the Key	7
Install the SD Card	7
Connect to an EtherNet/IP Network	7
Confirm Installation	7
Specifications - ControlLogix 5580 Standard Controllers	8
Specifications - ControlLogix 5580 NSE Controllers	8
Specifications - ControlLogix 5580 Process Controllers	9
Specifications - ControlLogix 5580 Harsh Environment Controllers	10
Additional Resources	11

The ControlLogix® 5580 controllers help enable faster system performance, capacity, productivity, and security to help meet the growing demands of smart machines and equipment for manufacturing.

- Integrated Motion over EtherNet/IP™ for up to 256 axes.
- 1 Gb embedded Ethernet port enables high performance, communications, I/O, and motion control.
- Secure Digital (SD) card provides optional nonvolatile memory to store user program and tag data on the controller.
- Digitally signed and encrypted firmware helps protect against malicious intent.
- ControlLogix NSE controllers deplete their residual stored energy to specific levels.
- ControlLogix Process controllers are optimized for process applications.
- Select ControlLogix-XT™ controllers feature extended temperature limits.
- ControlLogix controllers with an 'NSE', 'P', 'K', or 'XT' in the catalog number are conformal coated for extended protection in harsh, corrosive environments.

## Summary of Changes

This publication contains the following new or updated information. This list includes substantive updates only and is not intended to reflect all changes.

Topic	Page
Updated the Parts List section	5



**ATTENTION:** Read this document and the documents listed in the Additional Resources section about installation, configuration and operation of this equipment before you install, configure, operate or maintain this product. Users are required to familiarize themselves with installation and wiring instructions in addition to requirements of all applicable codes, laws, and standards.

Activities including installation, adjustments, putting into service, use, assembly, disassembly, and maintenance are required to be carried out by suitably trained personnel in accordance with applicable code of practice. If this equipment is used in a manner not specified by the manufacturer, the protection provided by the equipment may be impaired.

注意：在安装、配置、操作和维护本产品前，请阅读本文档以及“其他资源”部分列出的有关设备安装、配置和操作的相应文档。除了所有适用规范、法律和标准的相关要求之外，用户还必须熟悉安装和接线说明。

安装、调整、投运、使用、组装、拆卸和维护等各项操作必须由经过适当训练的专业人员按照适用的操作规范实施。

如果未按照制造商指定的方式使用该设备，则可能会损害设备提供的保护。

**ATENCIÓN:** Antes de instalar, configurar, poner en funcionamiento o realizar el mantenimiento de este producto, lea este documento y los documentos listados en la sección Recursos adicionales acerca de la instalación, configuración y operación de este equipo. Los usuarios deben familiarizarse con las instrucciones de instalación y cableado y con los requisitos de todos los códigos, leyes y estándares vigentes.

El personal debidamente capacitado debe realizar las actividades relacionadas a la instalación, ajustes, puesta en servicio, uso, ensamblaje, desensamblaje y mantenimiento de conformidad con el código de práctica aplicable. Si este equipo se usa de una manera no especificada por el fabricante, la protección provista por el equipo puede resultar afectada.

**ATENÇÃO:** Leia este e os demais documentos sobre instalação, configuração e operação do equipamento que estão na seção Recursos adicionais antes de instalar, configurar, operar ou manter este produto. Os usuários devem se familiarizar com as instruções de instalação e fiação além das especificações para todos os códigos, leis e normas aplicáveis.

É necessário que as atividades, incluindo instalação, ajustes, colocação em serviço, utilização, montagem, desmontagem e manutenção sejam realizadas por pessoal qualificado e especializado, de acordo com o código de prática aplicável.

Caso este equipamento seja utilizado de maneira não estabelecida pelo fabricante, a proteção fornecida pelo equipamento pode ficar prejudicada.

**ВНИМАНИЕ:** Перед тем как устанавливать, настраивать, эксплуатировать или обслуживать данное оборудование, прочитайте этот документ и документы, перечисленные в разделе «Дополнительные ресурсы». В этих документах изложены сведения об установке, настройке и эксплуатации данного оборудования. Пользователи обязаны ознакомиться с инструкциями по установке и прокладке соединений, а также с требованиями всех применимых норм, законов и стандартов.

Все действия, включая установку, наладку, ввод в эксплуатацию, использование, сборку, разборку и техническое обслуживание, должны выполняться обученным персоналом в соответствии с применимыми нормами и правилами.

Если оборудование используется не предусмотренным производителем образом, защита оборудования может быть нарушена.

注意：本製品を設置、構成、稼働または保守する前に、本書および本機器の設置、設定、操作についての参考資料の該当箇所に記載されている文書に目を通してください。ユーザーは、すべての該当する条例、法律、規格の要件に加えて、設置および配線の手順に習熟している必要があります。

設置調整、運転の開始、使用、組立て、解体、保守を含む諸作業は、該当する実施規則に従って訓練を受けた適切な作業員が実行する必要があります。

本機器が製造メーカーにより指定されていない方法で使用されている場合、機器により提供されている保護が損なわれる恐れがあります。

**ACHTUNG:** Lesen Sie dieses Dokument und die im Abschnitt „Weitere Informationen“ aufgeführten Dokumente, die Informationen zu Installation, Konfiguration und Bedienung dieses Produkts enthalten, bevor Sie dieses Produkt installieren, konfigurieren, bedienen oder warten. Anwender müssen sich neben den Bestimmungen aller anwendbaren Vorschriften, Gesetze und Normen zusätzlich mit den Installations- und Verdrahtungsanweisungen vertraut machen.

Arbeiten im Rahmen der Installation, Anpassung, Inbetriebnahme, Verwendung, Montage, Demontage oder Instandhaltung dürfen nur durch ausreichend geschulte Mitarbeiter und in Übereinstimmung mit den anwendbaren Ausführungsvorschriften vorgenommen werden.

Wenn das Gerät in einer Weise verwendet wird, die vom Hersteller nicht vorgesehen ist, kann die Schutzfunktion beeinträchtigt sein.

**ATTENTION:** Lisez ce document et les documents listés dans la section Ressources complémentaires relatifs à l'installation, la configuration et le fonctionnement de cet équipement avant d'installer, configurer, utiliser ou entretenir ce produit. Les utilisateurs doivent se familiariser avec les instructions d'installation et de câblage en plus des exigences relatives aux codes, lois et normes en vigueur. Les activités relatives à l'installation, le réglage, la mise en service, l'utilisation, l'assemblage, le démontage et l'entretien doivent être réalisées par des personnes formées selon le code de pratique en vigueur.

Si cet équipement est utilisé d'une façon qui n'a pas été définie par le fabricant, la protection fournie par l'équipement peut être compromise.

주의：본 제품 설치, 설정, 작동 또는 유지 보수하기 전에 본 문서를 포함하여 설치, 설정 및 작동에 관한 참고 자료 섹션의 문서들을 반드시 읽고 숙지하십시오. 사용자는 모든 관련 규정, 법규 및 표준에서 요구하는 사항에 대해 반드시 설치 및 배선 지침을 숙지해야 합니다.

설치, 조정, 가동, 사용, 조립, 분해, 유지보수 등 모든 작업은 관련 규정에 따라 적절한 교육을 받은 사용자를 통해서만 수행해야 합니다.

본 장비를 제조사가 명시하지 않은 방법으로 사용하면 장비의 보호 기능이 손상될 수 있습니다.

**ATTENZIONE:** Prima di installare, configurare ed utilizzare il prodotto, o effettuare interventi di manutenzione su di esso, leggere il presente documento ed i documenti elencati nella sezione "Altre risorse", riguardanti l'installazione, la configurazione ed il funzionamento dell'apparecchiatura. Gli utenti devono leggere e comprendere le istruzioni di installazione e cablaggio, oltre ai requisiti previsti dalle leggi, codici e standard applicabili.

Le attività come installazione, regolazioni, utilizzo, assemblaggio, disassemblaggio e manutenzione devono essere svolte da personale adeguatamente addestrato, nel rispetto delle procedure previste. Qualora l'apparecchio venga utilizzato con modalità diverse da quanto previsto dal produttore, la sua funzione di protezione potrebbe venire compromessa.

**DİKKAT:** Bu ürünün kurulumu, yapılandırılması, işletilmesi veya bakımı öncesinde bu dokümanı ve bu ekipmanın kurulumu, yapılandırılması ve işletimi ile ilgili Kaynaklar bölümünde yer listelenmiş dokümanları okuyun. Kullanıcılar yürürlükteki tüm yönetmelikler, yasalar ve standartların gereksinimlerine ek olarak kurulum ve kablolama talimatlarını da öğrenmek zorundadır.

Kurulum, ayarlama, hizmete alma, kullanma, parçaları birleştirme, parçaları sökme ve bakım gibi aktiviteler sadece uygun eğitimleri almış kişiler tarafından yürürlükteki uygulama yönetmeliklerine uygun şekilde yapılabilir.

Bu ekipman üretici tarafından belirlenmiş amacın dışında kullanılırsa, ekipman tarafından sağlanan koruma bozulabilir.

注意事項：在安装、設定、操作或維護本產品前，請先閱讀此文件以及列於「其他資源」章節中有關安裝、設定與操作此設備的文件。使用者必須熟悉安裝和配線指示，並符合所有法規、法律和標準要求。

包括安裝、調整、交付使用、使用、組裝、拆卸和維護等動作都必須交由已經過適當訓練的人員進行，以符合適用的實作法規。

如果將設備用於非製造商指定的用途時，可能會造成設備所提供的保護功能受損。

**POZOR:** Než začnete instalovat, konfigurovat či provázovat tento výrobek nebo provádět jeho údržbu, přečtěte si tento dokument a dokumenty uvedené v části Dodatečné zdroje ohledně instalace, konfigurace a provozu tohoto zařízení. Uživatelé se musejí vedle požadavků všech relevantních vyhlášek, zákonů a norem nutně seznámit také s pokyny pro instalaci a elektrické zapojení.

Činnosti zahrnující instalaci, nastavení, uvedení do provozu, užívání, montáž, demontáž a údržbu musí vykonávat vhodně proškolený personál v souladu s příslušnými prováděcími předpisy.

Pokud se toto zařízení používá způsobem neodpovídajícím specifikaci výrobce, může být narušena ochrana, kterou toto zařízení poskytuje.

**UWAGA:** Przed instalacją, konfiguracją, użytkowaniem lub konserwacją tego produktu należy przeczytać niniejszy dokument oraz wszystkie dokumenty wymienione w sekcji Dodatkowe źródła omawiające instalację, konfigurację i procedury użytkowania tego urządzenia. Użytkownicy mają obowiązek zapoznać się z instrukcjami dotyczącymi instalacji oraz oprzewodowania, jak również z obowiązującymi kodeksami, prawem i normami.

Działania obejmujące instalację, regulację, przekazanie do użytkowania, użytkowanie, montaż, demontaż oraz konserwację muszą być wykonywane przez odpowiednio przeszkolony personel zgodnie z obowiązującym kodeksem postępowania.

Jeśli urządzenie jest użytkowane w sposób inny niż określony przez producenta, zabezpieczenie zapewniane przez urządzenie może zostać ograniczone.

**OBES!** Läs detta dokument samt dokumentet, som står listat i avsnittet Övriga resurser, om installation, konfigurering och drift av denna utrustning innan du installerar, konfigurerar eller börjar använda eller utföra underhållsarbete på produkten. Användare måste bekanta sig med instruktioner för installation och kabeldragning, förutom krav enligt gällande koder, lagar och standarder.

Om gårdar som installation, justering, service, användning, montering, demontering och underhållsarbete måste utföras av personal med lämplig utbildning enligt lämpligt bruk.

Om denna utrustning används på ett sätt som inte anges av tillverkaren kan det hända att utrustningens skyddsanordningar försätts ur funktion.

**LET OP:** Lees dit document en de documenten die genoemd worden in de paragraaf Aanvullende informatie over de installatie, configuratie en bediening van deze apparatuur voordat u dit product installeert, configureert, bedient of onderhoudt. Gebruikers moeten zich vertrouwd maken met de installatie en de bedringsinstructies, naast de vereisten van alle toepasselijke regels, wetten en normen.

Activiteiten zoals het installeren, afstellen, in gebruik stellen, gebruiken, monteren, demonteren en het uitvoeren van onderhoud mogen uitsluitend worden uitgevoerd door hiervoor opgeleid personeel en in overeenstemming met de geldende praktijkregels.

Indien de apparatuur wordt gebruikt op een wijze die niet is gespecificeerd door de fabrikant, dan bestaat het gevaar dat de beveiliging van de apparatuur niet goed werkt.

## Product Advisories



**ATTENTION:**



- In case of malfunction or damage, no attempts at repair should be made. The controller should be returned to the manufacturer for repair. Do not dismantle the controller.
- The USB port is intended for temporary local programming purposes only and not intended for permanent connection. The USB cable is not to exceed 3.0 m (9.84 ft) and must not contain hubs.
- Use only a soft dry anti-static cloth to wipe down equipment. Do not use any cleaning agents.
- When ControlLogix 5580 standard, conformal coated, and ControlLogix 5580 NSE controllers are installed in a 1756 series B chassis, this equipment is certified for use only within the surrounding air temperature range of 0...50 °C (32...122 °F). The equipment must not be used outside of this range.
- When ControlLogix 5580 standard, conformal coated, and ControlLogix 5580 NSE controllers are installed in a 1756 series C chassis, this equipment is certified for use only within the surrounding air temperature range of 0...60 °C (32...140 °F). The equipment must not be used outside of this range.
- When ControlLogix 5580 Process controllers are installed in a 1756 Series B Chassis, this equipment is certified for use only within the surrounding air temperature range of -25...+50 °C (-13...+122 °F). The equipment must not be used outside of this range.
- When ControlLogix 5580 Process controllers are installed in a 1756 Series C Chassis, this equipment is certified for use only within the surrounding air temperature range of -25...+60 °C (-13...+140 °F). The equipment must not be used outside of this range.
- When ControlLogix-Xt 5580 controllers and ControlLogix 5580 Process controllers are installed in a ControlLogix-Xt series C chassis, this equipment is certified for use only within the surrounding air temperature range of -25...+70 °C (-13...+158 °F). The equipment must not be used outside of this range.
- When ControlLogix-Xt 5580 controllers and ControlLogix 5580 Process controllers are installed in a ControlLogix-Zxt chassis, this equipment is certified for use only within the surrounding air temperature range of -25...+70 °C (-13...+158 °F). The equipment must not be used outside of this range.



**WARNING:**

- When you press the reset button while power is on, an electric arc can occur. This could cause an explosion in hazardous location installations.
- Be sure that power is removed or the area is nonhazardous before proceeding.
- Do not use the USB port in hazardous locations.

### North American Hazardous Location Approval

The following information applies when operating this equipment in hazardous locations.	Informations sur l'utilisation de cet équipement en environnements dangereux.
<p>Products marked "CL I, DIV 2, GP A, B, C, D" are suitable for use in Class I Division 2 Groups A, B, C, D, Hazardous Locations and nonhazardous locations only. Each product is supplied with markings on the rating nameplate indicating the hazardous location temperature code. When combining products within a system, the most adverse temperature code (lowest "T" number) may be used to help determine the overall temperature code of the system. Combinations of equipment in your system are subject to investigation by the local Authority Having Jurisdiction at the time of installation.</p>	<p>Les produits marqués "CL I, DIV 2, GP A, B, C, D" ne conviennent qu'à une utilisation en environnements de Classe I Division 2 Groupes A, B, C, D dangereux et non dangereux. Chaque produit est livré avec des marquages sur sa plaque d'identification qui indiquent le code de température pour les environnements dangereux. Lorsque plusieurs produits sont combinés dans un système, le code de température le plus défavorable (code de température le plus faible) peut être utilisé pour déterminer le code de température global du système. Les combinaisons d'équipements dans le système sont sujettes à inspection par les autorités locales qualifiées au moment de l'installation.</p>
 <p><b>WARNING:</b> <b>Explosion Hazard –</b></p> <ul style="list-style-type: none"> <li>• Do not disconnect equipment unless power has been removed or the area is known to be nonhazardous.</li> <li>• Do not disconnect connections to this equipment unless power has been removed or the area is known to be nonhazardous. Secure any external connections that mate to this equipment by using screws, sliding latches, threaded connectors, or other means provided with this product.</li> <li>• Substitution of components may impair suitability for Class I, Division 2.</li> <li>• If this product contains batteries, they must only be changed in an area known to be nonhazardous.</li> </ul>	 <p><b>AVERTISSEMENT:</b> <b>Risque d'Explosion –</b></p> <ul style="list-style-type: none"> <li>• Couper le courant ou s'assurer que l'environnement est classé non dangereux avant de débrancher l'équipement.</li> <li>• Couper le courant ou s'assurer que l'environnement est classé non dangereux avant de débrancher les connecteurs. Fixer tous les connecteurs externes reliés à cet équipement à l'aide de vis, loquets coulissants, connecteurs filetés ou autres moyens fournis avec ce produit.</li> <li>• La substitution de composants peut rendre cet équipement inadapté à une utilisation en environnement de Classe I, Division 2.</li> <li>• S'assurer que l'environnement est classé non dangereux avant de changer les piles.</li> </ul>

### UK and European Hazardous Location Approval

The following applies to products marked , II 3 G. Such products:

- Are Equipment Group II, Equipment Category 3, and comply with the Essential Health and Safety Requirements relating to the design and construction of such equipment given in Annex II to EU Directive 2014/34/EU and Schedule 1 of the UKEX Regulation 2016 No. 1107. See the UKEX and EU Declaration of Conformity at [rok.auto/certifications](http://rok.auto/certifications) for details.
- The type of protection is <Ex ec IIC T4 Gc> Equipment protection by increased safety "e".
- Equipment protection by increased safety "e", reference certificate number UL22ATEX2817X and UL22UKEX2601X.
- Are intended for use in areas in which explosive atmospheres caused by gases, vapors, mists, or air are unlikely to occur, or are likely to occur only infrequently and for short periods. Such locations correspond to Zone 2 classification according to UKEX Regulation 2016 No. 1107 and ATEX directive 2014/34/EU.

### IEC Hazardous Location Approval

The following applies to products with IECEx certification.

- Such products are intended for use in areas in which explosive atmospheres caused by gases, vapors, mists, or air are unlikely to occur, or are likely to occur only infrequently and for short periods. Such locations correspond to Zone 2 classification.
- The type of protection is <Ex ec IIC T4 Gc>.
- IECEx certificate number IECEx UL 22.0062X.

### Special Conditions for Safe Use

---



**WARNING:**

- This equipment is not resistant to sunlight or other sources of UV radiation.
  - This equipment shall be mounted in an ATEX/IECEX Zone 2 certified enclosure with a minimum ingress protection rating of at least IP54 (in accordance with EN/IEC 60079-0) and used in an environment of not more than Pollution Degree 2 (as defined in EN/IEC 60664-1) when applied in Zone 2 environments. The enclosure must be accessible only by the use of a tool.
  - This equipment shall be used within its specified ratings defined by Rockwell Automation.
  - Provision shall be made to prevent the rated voltage from being exceeded by transient disturbances of more than 140% of the peak rated voltage when applied in Zone 2 environments.
  - The instructions in the user manual shall be observed.
  - Secure any external connections that mate to this equipment by using screws, sliding latches, threaded connectors, or other means provided with this product.
  - Do not disconnect equipment unless power has been removed or the area is known to be nonhazardous.
  - This equipment must be used only with ATEX/IECEX certified Rockwell Automation® backplanes.
  - The USB port is intended for temporary local programming purposes only and not intended for permanent connection. Do not use the USB port in hazardous locations.
- 

### Environment and Enclosure

---



**ATTENTION:**

This equipment is intended for use in a Pollution Degree 2 industrial environment, in overvoltage Category II applications (as defined in EN 60664-1), at altitudes up to 2000 m (6562 ft) without derating.

This equipment isn't intended for use in residential environments and may not provide adequate protection to radio communication services in such environments.

This equipment is supplied as open-type equipment for indoor use. It must be mounted within an enclosure that is suitably designed for those specific environmental conditions that will be present and appropriately designed to prevent personal injury resulting from accessibility to live parts. The enclosure must have suitable flame-retardant properties to prevent or minimize the spread of flame, complying with a flame spread rating of 5VA or be approved for the application if non-metallic. The interior of the enclosure must be accessible only by the use of a tool. Subsequent sections of this publication may contain more information regarding specific enclosure type ratings that are required to comply with certain product safety certifications.

In addition to this publication, see the following:

- Industrial Automation Wiring and Grounding Guidelines, publication [1770-4.1](#), for more installation requirements.
  - NEMA Standard 250 and EN/IEC 60529, as applicable, for explanations of the degrees of protection provided by different types of enclosure.
- 

**IMPORTANT**

Any illustrations, charts, sample programs, and layout examples that are shown in this publication are intended solely for the purposes of example. Since there are many variables and requirements that are associated with any particular installation, Rockwell Automation does not assume responsibility or liability for actual use based on the examples that are shown in this publication.

---

## Parts List

The controller ships with these parts:

- A key for the mode switch (1756-KY1)
- 4 GB Secure Digital Card (1784-SD4), preinstalled in ControlLogix standard controllers
- 4 GB Secure Digital Card (1784-SD4XT), preinstalled in ControlLogix-XT controllers

## Required System Components

To use the controller, a chassis and power supply are required. For controller and chassis operating specifications, see the 1756 ControlLogix Controller Specifications Technical Data, publication [1756-TD001](#).

Component	Catalog Number
ControlLogix Chassis, series C and series B	1756-A4, 1756-A4K, 1756-A7, 1756-A7K, 1756-A10, 1756-A10K, 1756-A13, 1756-A13K, 1756-A17, 1756-A17K
ControlLogix Power Supply	1756-PA72, 1756-PA72K, 1756-PA75, 1756-PA75K, 1756-PB72, 1756-PB72K, 1756-PB75, 1756-PB75K, 1756-PC75, 1756-PH75 1756-PA50, 1756-PA50K, 1756-PB50, 1756-PB50K 1756-PA75R, 1756-PA75RK, 1756-PB75R, 1756-PB75RK, 1756-PSCA2, 1756-PSCA2K
ControlLogix-ZXT Chassis or ControlLogix-XT Chassis, series C	1756-A7ZXT, 1756-A10ZXT 1756-A7XT, 1756-A10XT
ControlLogix-XT Power Supply	1756-PAXT, 1756-PBXT 1756-PA30XT, 1756-PB30XT 1756-PAXTR, 1756-PBXTR 1756-PA75XT, 1756-PB75XT

## Product Dimensions

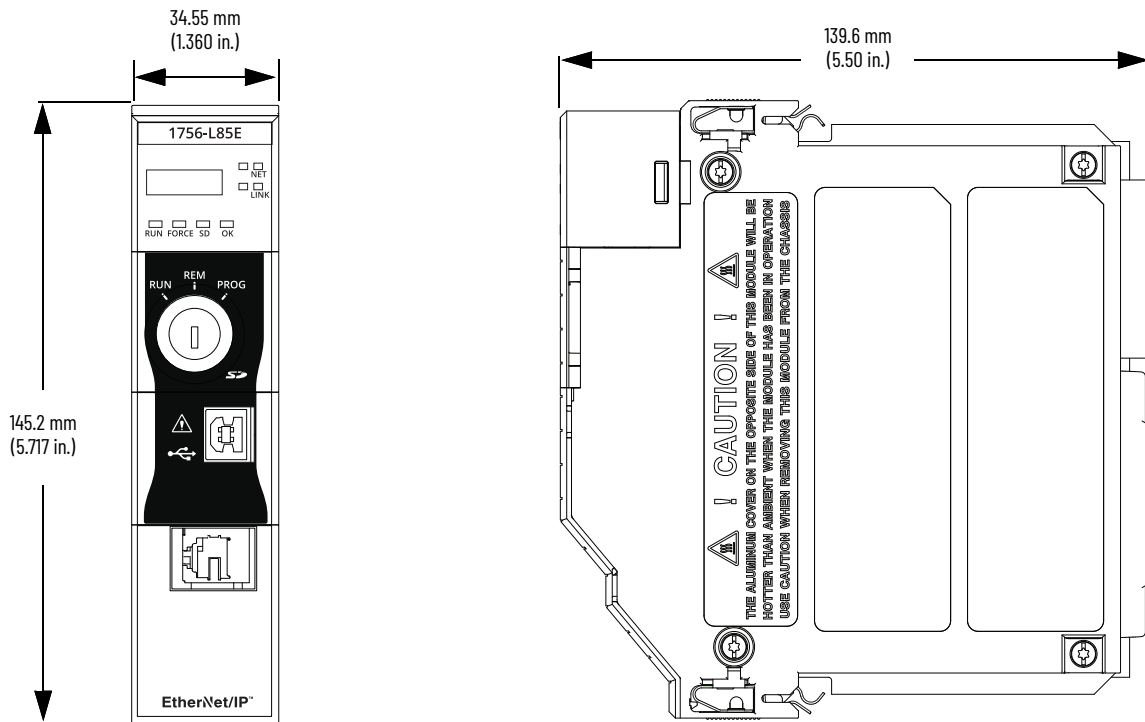

## Connectors and Status Indicators

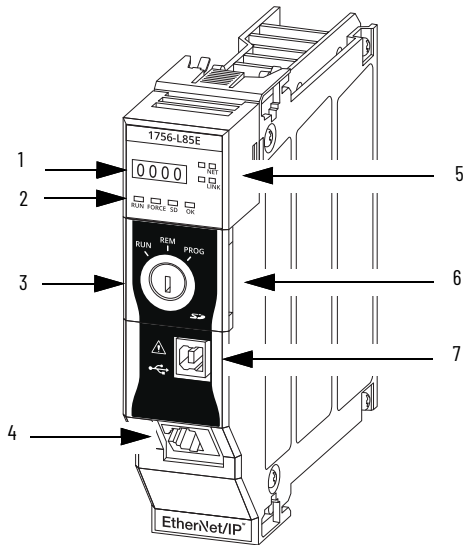

Item	Description
1	4-character display
2	Status Indicators
3	Mode switch (Remote, Run, Program)
4	Ethernet Port
5	Ethernet Status Indicators
6	SD card slot and Reset Button are behind the door.
7	USB Port

## Install the Controller



**ATTENTION:** If you are using a ControlLogix 5580 Standard or NSE controller to the maximum temperature of 60 °C (140 °F), you must use a ControlLogix chassis, series C. If you're using a ControlLogix-XT or ControlLogix Process controller to the maximum temperature of 70 °C (158 °F), you must use a ControlLogix-ZXT chassis or a ControlLogix-XT chassis, series C.



**WARNING:** When you insert or remove the controller while backplane power is on, an electric arc can occur. This could cause an explosion in hazardous location installations. Be sure that power is removed or the area is nonhazardous before proceeding. Repeated electrical arcing causes excessive wear to contacts on both the controller and its mating connector. Worn contacts can create electrical resistance that can affect controller operation.



**ATTENTION:** The ControlLogix 5580 controllers listed on [page 1](#) that end with a 'K', 'NSE', 'P', or 'XT' are shipped with port protection plugs/covers installed to provide a layer of protection from corrosive atmospheres. Once the factory packaging seal is broken, the port plugs/covers must remain installed in unused ports at all times for the product to maintain its corrosive atmosphere rating. If temporary access is required, plugs can be removed, but should be reinserted after temporary access is complete.

Before you install the controller, make sure to see these ControlLogix® Chassis and Power Supply Installation Instructions:

- ControlLogix Chassis Installation Instructions, publication [1756-IN621](#)
- ControlLogix Power Supply Installation Instructions, publication [1756-IN619](#)
- ControlLogix Redundant Power Supply Installation Instructions, publication [1756-IN620](#)

When installing a ControlLogix controller, you can do the following:

- Place the controller in any slot.
- Use multiple controllers in the same chassis.

You can install or remove a ControlLogix controller while chassis power is on and the system is operating.



**ATTENTION:** This equipment is sensitive to electrostatic discharge, which can cause internal damage and affect normal operation.

Follow these guidelines when you handle this equipment:

- Touch a grounded object to discharge potential static.
- Wear an approved grounding wriststrap.
- Do not touch connectors or pins on component boards.
- Do not touch circuit components inside the equipment.
- Use a static-safe workstation, if available.
- Store the equipment in appropriate static-safe packaging when not in use.

1. If you're using a ControlLogix-ZXT chassis, remove the backplane connector cover from the slot into which you're installing the controller.



**ATTENTION:** ControlLogix-ZXT chassis are shipped with backplane connector covers installed to provide a layer of protection from corrosive atmospheres. Once the factory packaging seal is broken, these covers must remain installed in unused slots at all times for the chassis to maintain its corrosive atmosphere rating. If the controller is later removed, reinstall a backplane connector cover in the vacated slot to maintain the corrosive atmosphere rating of the chassis.

2. Align the circuit board with the top and bottom guides in the chassis.

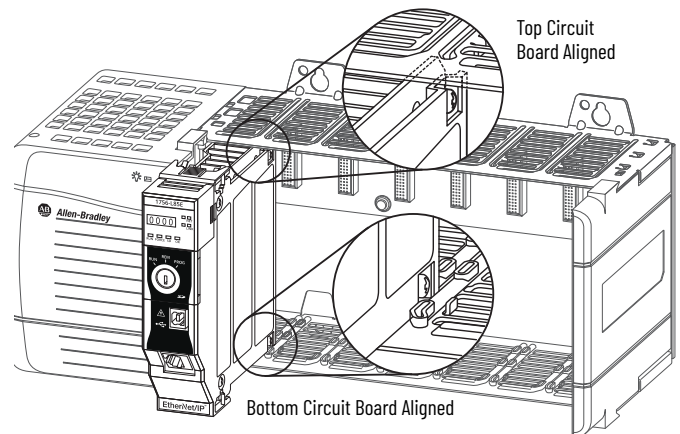

3. Slide the controller into the chassis until it snaps into place.
4. Verify that the controller is flush with the power supply, modules, or other installed system components.

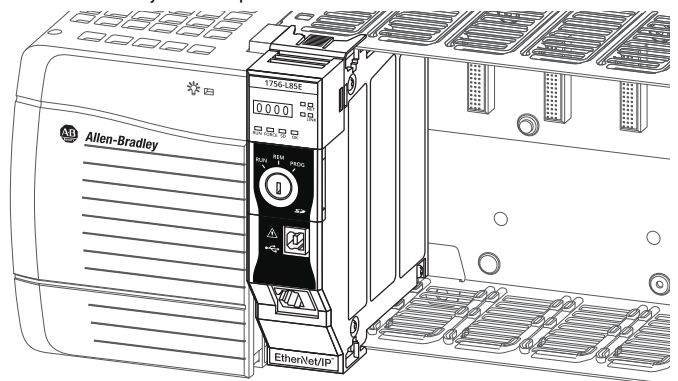

## Insert the Key

After the controller is installed, insert the key.

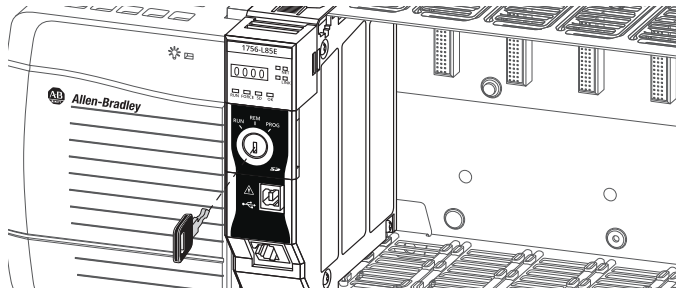

## Install the SD Card



**WARNING:** When you insert or remove the SD memory card while power is on, an electric arc can occur. This could cause an explosion in hazardous location installations. Be sure that power is removed or the area is nonhazardous before proceeding.

If the SD card is not already installed in the controller, then complete these steps to install the SD card.

1. Verify that the SD card is locked or unlocked according to your preference.

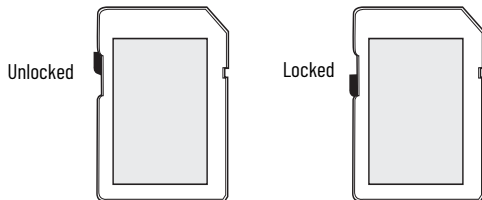

For more information about the SD lock/unlock settings, see the ControlLogix 5580 Controllers User Manual, publication [1756-UM543](#).

2. Remove the key.
3. To access the SD card slot, open the door on the controller key panel.

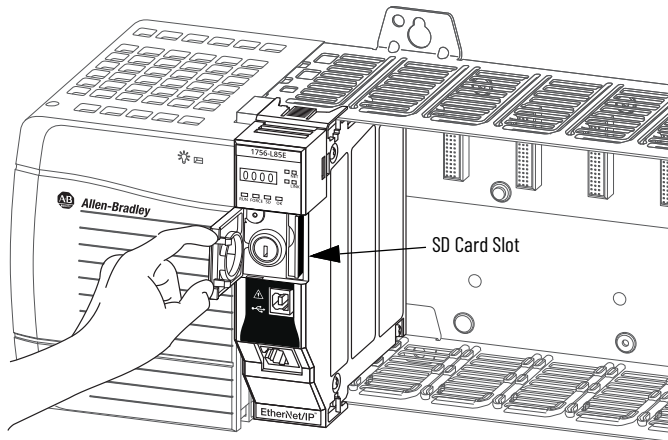

4. Position the SD card so that the contact end goes into the controller, with the contacts on the right and the label on the left. The beveled corner is on top.

SD Card

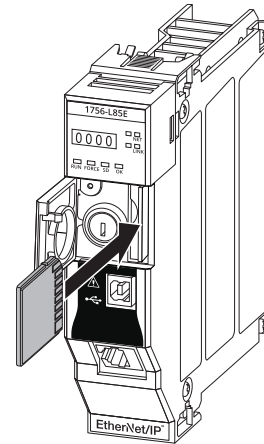

5. Insert the SD card into the card slot and gently press the card until it clicks into place.
6. The card slides in easily, if it is oriented correctly. You can insert the card only one way.
7. Close the door.

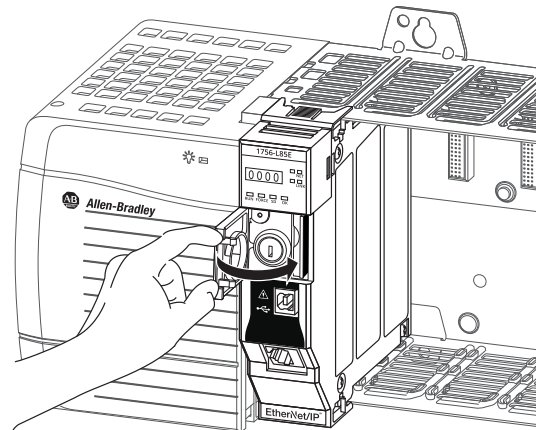

8. Reinsert the key, if desired.

## Connect to an EtherNet/IP Network



**WARNING:** If you connect or disconnect the communications cable with power applied to this controller or any device on the network, an electric arc can occur. This could cause an explosion in hazardous location installations. Be sure that power is removed or the area is nonhazardous before proceeding.

If you are connecting the controller directly to an EtherNet/IP network, then connect an RJ45 cable to the Ethernet port on the controller.



**ATTENTION:** 10 Mbps Ethernet automatic negotiations are functional, however, they are not fully supported or intended for normal use. Use 10 Mbps Ethernet connections, only if necessary, during temporary setup.

## Confirm Installation

After you have inserted the controller into the chassis and applied power, the 4-character display and status indicators display status information for the controller. See the ControlLogix 5580 and GuardLogix 5580 Controllers User Manual, publication [1756-UM543](#), for information on how to interpret the 4-character display messages and the status indicators.

## Specifications - ControlLogix 5580 Standard Controllers

Attribute	1756-L81E, 1756-L82E, 1756-L83E, 1756-L84E, 1756-L85E
Temperature, operating IEC 60068-2-1 (Test Ae, Operating Cold), IEC 60068-2-2 (Test Be, Operating Dry Heat), IEC 60068-2-14 (Test Nb, Operating Thermal Shock)	0 °C ≤ Ta ≤ +60 °C (+32 °F ≤ Ta ≤ +140 °F) for Standard Chassis, Series C 0 °C ≤ Ta ≤ +50 °C (+32 °F ≤ Ta ≤ +122 °F) for Standard Chassis, Series B
Temperature, Surrounding Air max	60 °C (140 °F) for Standard Chassis, Series C 50 °C (122 °F) for Standard Chassis, Series B
Conformal Coated	No
Enclosure type rating	None (open-style)
Voltage and current ratings	1200 mA @ 5.1V DC 5.0 mA @ 1.2V DC
Isolation Voltage	50V (continuous), Basic Insulation type, USB port to Backplane, Ethernet port to Backplane, and USB Port to Ethernet port. Type tested at 1000V AC for 60 seconds
Weight, approx	394 g (0.868 lb)
Wire size	Ethernet cabling and installation according to IEC 61918 and IEC 61784-5-2
Temperature code	T4

## Specifications - ControlLogix 5580 NSE Controllers

Attribute	1756-L81E-NSE, 1756-L82E-NSE, 1756-L83E-NSE, 1756-L84E-NSE, 1756-L85E-NSE	1756-L81E-NSEXT, 1756-L82E-NSEXT, 1756-L83E-NSEXT, 1756-L84E-NSEXT, 1756-L85E-NSEXT	
Temperature, operating IEC 60068-2-1 (Test Ae, Operating Cold), IEC 60068-2-2 (Test Be, Operating Dry Heat), IEC 60068-2-14 (Test Nb, Operating Thermal Shock)	0 °C ≤ Ta ≤ +60 °C (+32 °F ≤ Ta ≤ +140 °F) for Standard Chassis, Series C 0 °C ≤ Ta ≤ +50 °C (+32 °F ≤ Ta ≤ +122 °F) for Standard Chassis, Series B	-25 °C ≤ Ta ≤ +70 °C (-13 °F ≤ Ta ≤ +158 °F) for XT Chassis, Series C	-25 °C ≤ Ta ≤ +70 °C (-13 °F ≤ Ta ≤ +158 °F) for ZXT Chassis
Temperature, Surrounding Air max	60 °C (140 °F) for Standard Chassis, Series C 50 °C (122 °F) for Standard Chassis, Series B	70 °C (158 °F) for XT Chassis, Series C	70 °C (158 °F) for ZXT Chassis
Corrosive Atmosphere • ASTM B845-97 Method K Accelerated Test (20-Day Exposure)	Severity Level G3 <sup>(1)(2)</sup> per ANSI/ISA 71.04-2013, Airborne Contaminants—Gases Severity Level CX <sup>(1)</sup> per IEC 60721-3-3:2019, Chemically Active Substances	—	
Corrosive Atmosphere • ASTM B845-97 Method K Accelerated Test (30-Day Exposure) plus additional Rockwell Automation proprietary accelerated corrosive environment test protocol for specific industries with sources of gaseous sulfur compounds.	—	Severity Level GX <sup>(3)(4)</sup> per ANSI/ISA 71.04-2013, Airborne Contaminants—Gases Severity Level CX <sup>(3)</sup> per IEC 60721-3-3:2019, Chemically Active Substances	
Conformal Coated	Yes		
Enclosure type rating	None (open-style)		
Voltage and current ratings	1200 mA @ 5.1V DC 5.0 mA @ 1.2V DC		
Isolation Voltage	50V (continuous), Basic Insulation type, USB port to Backplane, Ethernet port to Backplane, and USB Port to Ethernet port. Type tested at 1000V AC for 60 seconds		
Weight, approx	394 g (0.868 lb)		
Wire size	Ethernet cabling and installation according to IEC 61918 and IEC 61784-5-2		
Temperature code	T4		

(1) Port plugs/covers must remain installed in unused ports at all times during storage and operation for the product to maintain its corrosive atmosphere rating.

(2) Up to 86.4 g/(m<sup>2</sup>·yr), mass loss of copper due to corrosion.

(3) Port plugs/covers must remain installed in unused ports at all times, once the XT packaging seal is broken, for the product to maintain its corrosive atmosphere rating.

(4) Up to 2100 angstroms of film growth per 30 days of copper and/or silver reactivity.

## Specifications - ControlLogix 5580 Process Controllers

Attribute	1756-L81EP, 1756-L83EP, 1756-L85EP	1756-L81EPXT, 1756-L83EPXT, 1756-L85EPXT	
Temperature, operating IEC 60068-2-1 (Test Ae, Operating Cold), IEC 60068-2-2 (Test Be, Operating Dry Heat), IEC 60068-2-14 (Test Nb, Operating Thermal Shock)	-25 °C ≤ Ta ≤ +60 °C (-13 °F ≤ Ta ≤ +140 °F) for Standard Chassis, Series C -25 °C ≤ Ta ≤ +50 °C (-13 °F ≤ Ta ≤ +122 °F) for Standard Chassis, Series B -25 °C ≤ Ta ≤ +70 °C (-13 °F ≤ Ta ≤ +158 °F) for XT Chassis, Series C -25 °C ≤ Ta ≤ +70 °C (-13 °F ≤ Ta ≤ +158 °F) for ZXT Chassis	-25 °C ≤ Ta ≤ +70 °C (-13 °F ≤ Ta ≤ +158 °F) for XT Chassis, Series C	-25 °C ≤ Ta ≤ +70 °C (-13 °F ≤ Ta ≤ +158 °F) for ZXT Chassis
Temperature, Surrounding Air max	60 °C (140 °F) for Standard Chassis, Series C 50 °C (122 °F) for Standard Chassis, Series B 70 °C (158 °F) for XT Chassis, Series C 70 °C (158 °F) for ZXT Chassis	70 °C (158 °F) for XT Chassis, Series C	70 °C (158 °F) for ZXT Chassis
Conformal Coated	Yes		
Corrosive Atmosphere • ASTM B845-97 Method K Accelerated Test (20-Day Exposure)	Severity Level G3 <sup>(1)(2)</sup> per ANSI/ISA 71.04-2013, Airborne Contaminants—Gases Severity Level CX <sup>(1)</sup> per IEC 60721-3-3:2019, Chemically Active Substances		—
Corrosive Atmosphere • ASTM B845-97 Method K Accelerated Test (30-Day Exposure) plus additional Rockwell Automation proprietary accelerated corrosive environment test protocol for specific industries with sources of gaseous sulfur compounds.	—		Severity Level GX <sup>(3)(4)</sup> per ANSI/ISA 71.04-2013, Airborne Contaminants—Gases Severity Level CX <sup>(3)</sup> per IEC 60721-3-3:2019, Chemically Active Substances
Enclosure type rating	None (open-style)		
Voltage and current ratings	1200 mA @ 5.1V DC 5.0 mA @ 1.2V DC		
Isolation Voltage	50V (continuous), Basic Insulation type, USB port to Backplane, Ethernet port to Backplane, and USB Port to Ethernet port. Type tested at 1000V AC for 60 seconds		
Weight, approx	394 g (0.868 lb)		
Wire size	Ethernet cabling and installation according to IEC 61918 and IEC 61784-5-2		
Temperature code	T4		

(1) Port plugs/covers must remain installed in unused ports at all times during storage and operation for the product to maintain its corrosive atmosphere rating.

(2) Up to 86.4 g/(m<sup>2</sup>-yr), mass loss of copper due to corrosion.

(3) Port plugs/covers must remain installed in unused ports at all times, once the XT packaging seal is broken, for the product to maintain its corrosive atmosphere rating.

(4) Up to 2100 angstroms of film growth per 30 days of copper and/or silver reactivity.

## Specifications - ControlLogix 5580 Harsh Environment Controllers

Attribute	1756-L81EK, 1756-L82EK, 1756-L83EK, 1756-L84EK, 1756-L85EK	1756-L81EXT/B, 1756-L82EXT/B, 1756-L83EXT/B, 1756-L84EXT/B, 1756-L85EXT/B	1756-L81EXT/C, 1756-L82EXT/C, 1756-L83EXT/C, 1756-L84EXT/C, 1756-L85EXT/C	
Temperature, operating IEC 60068-2-1 (Test Ae, Operating Cold), IEC 60068-2-2 (Test Be, Operating Dry Heat), IEC 60068-2-14 (Test Nb, Operating Thermal Shock)	0 °C ≤ Ta ≤ +60 °C (+32 °F ≤ Ta ≤ +140 °F) for Standard Chassis, Series C 0 °C ≤ Ta ≤ +50 °C (+32 °F ≤ Ta ≤ +122 °F) for Standard Chassis, Series B	-25 °C ≤ Ta ≤ +70 °C (-13 °F ≤ Ta ≤ +158 °F) for XT Chassis, Series C -25 °C ≤ Ta ≤ +70 °C (-13 °F ≤ Ta ≤ +158 °F) for ZXT Chassis	-25 °C ≤ Ta ≤ +70 °C (-13 °F ≤ Ta ≤ +158 °F) for XT Chassis, Series C	-25 °C ≤ Ta ≤ +70 °C (-13 °F ≤ Ta ≤ +158 °F) for ZXT Chassis
Temperature, Surrounding Air max	60 °C (140 °F) for Standard Chassis, Series C 50 °C (122 °F) for Standard Chassis, Series B	70 °C (158 °F) for XT Chassis, Series C 70 °C (158 °F) for ZXT Chassis	70 °C (158 °F) for XT Chassis, Series C	70 °C (158 °F) for ZXT Chassis
Conformal Coated	Yes			
Corrosive Atmosphere • ASTM B845-97 Method K Accelerated Test (20-Day Exposure)	Severity Level G3 <sup>(1)(2)</sup> per ANSI/ISA 71.04-2013, Airborne Contaminants—Gases Severity Level CX <sup>(1)</sup> per IEC 60721-3-3:2019, Chemically Active Substances			—
Corrosive Atmosphere • ASTM B845-97 Method K Accelerated Test (30-Day Exposure) plus additional Rockwell Automation proprietary accelerated corrosive environment test protocol for specific industries with sources of gaseous sulfur compounds.	—			Severity Level GX <sup>(3)(4)</sup> per ANSI/ISA 71.04-2013, Airborne Contaminants—Gases Severity Level CX <sup>(3)</sup> per IEC 60721-3-3:2019, Chemically Active Substances
Enclosure type rating	None (open-style)			
Voltage and current ratings	1200 mA @ 5.1V DC 5.0 mA @ 1.2V DC			
Isolation Voltage	50V (continuous), Basic Insulation type, USB port to Backplane, Ethernet port to Backplane, and USB Port to Ethernet port. Type tested at 1000V AC for 60 seconds			
Weight, approx	394 g (0.868 lb)			
Wire size	Ethernet cabling and installation according to IEC 61918 and IEC 61784-5-2			
Temperature code	T4			

(1) Port plugs/covers must remain installed in unused ports at all times during storage and operation for the product to maintain its corrosive atmosphere rating.

(2) Up to 86.4 g/(m<sup>2</sup>-yr), mass loss of copper due to corrosion.

(3) Port plugs/covers must remain installed in unused ports at all times, once the XT packaging seal is broken, for the product to maintain its corrosive atmosphere rating.

(4) Up to 2100 angstroms of film growth per 30 days of copper and/or silver reactivity.

**IMPORTANT** ControlLogix-XT system components are rated for extreme environmental conditions **only** when used properly with other system components that share the same extreme-environment ratings. The extreme-environment ratings of ControlLogix-XT components are nullified when used with other system components that do not share comparable attributes.

**EXAMPLE:** If the temperature rating found in the Technical Data publication for your ControlLogix-XT controller is 70 °C and you pair it with a ControlLogix chassis rated for 60 °C, the system is rated 60 °C.

To ensure that your system is equipped for extreme environmental conditions, compare the corrosive atmosphere and temperature ratings found in the Technical Data publication for each system component.

**IMPORTANT** When a ControlLogix-XT controller is used as a replacement for a standard ControlLogix controller, all functional and environmental requirements of the standard ControlLogix controller apply, with the exception of the power output ratings.

## Additional Resources

These documents contain additional information concerning related products from Rockwell Automation.

Resource	Description
1756 ControlLogix Controller Specifications Technical Data, publication <a href="#">1756-TD001</a>	Provides controller specifications, including communication options, memory use, compatibilities, redundancy, and available accessories.
1756 ControlLogix Power Supplies Specifications Technical Data, publication <a href="#">1756-TD005</a>	Provides technical specifications for ControlLogix power supplies.
1756 ControlLogix Chassis Specifications Technical Data, publication <a href="#">1756-TD006</a>	Provides chassis specifications, including spacing requirements, mounting dimensions, and available accessories.
ControlLogix Chassis Installation Instructions, publication <a href="#">1756-IN621</a>	Provides information on how to install ControlLogix chassis.
ControlLogix Power Supply Installation Instructions, publication <a href="#">1756-IN619</a>	Provides information on how to install ControlLogix standard power supplies.
ControlLogix Redundant Power Supply Installation Instructions, publication <a href="#">1756-IN620</a>	Provides information on how to install ControlLogix redundant power supplies.
ControlLogix 5580 and GuardLogix 5580 Controllers User Manual, publication <a href="#">1756-UM543</a>	Provides information on how to configure, select I/O modules, manage communication, develop applications, and troubleshoot the ControlLogix 5580 controllers.
Replacement Guidelines: Logix 5000 Controllers Reference Manual, publication <a href="#">1756-RM100</a>	Compares ControlLogix 5580 controllers to ControlLogix 5560/5570 controllers, and provides guidelines on the features, functions, instruction updates, and differences between controllers.
Industrial Automation Wiring and Grounding Guidelines, publication <a href="#">1770-4.1</a>	Provides general guidelines for installing a Rockwell Automation industrial system.
Product Certifications website, <a href="http://rok.auto/certifications">rok.auto/certifications</a>	Provides declarations of conformity, certificates, and other certification details.

You can view or download publications at [rok.auto/literature](http://rok.auto/literature).

## Rockwell Automation Support

Use these resources to access support information.

<b>Technical Support Center</b>	Find help with how-to videos, FAQs, chat, user forums, Knowledgebase, and product notification updates.	<a href="http://rok.auto/support">rok.auto/support</a>
<b>Local Technical Support Phone Numbers</b>	Locate the telephone number for your country.	<a href="http://rok.auto/phonesupport">rok.auto/phonesupport</a>
<b>Technical Documentation Center</b>	Quickly access and download technical specifications, installation instructions, and user manuals.	<a href="http://rok.auto/techdocs">rok.auto/techdocs</a>
<b>Literature Library</b>	Find installation instructions, manuals, brochures, and technical data publications.	<a href="http://rok.auto/literature">rok.auto/literature</a>
<b>Product Compatibility and Download Center (PCDC)</b>	Download firmware, associated files (such as AOP, EDS, and DTM), and access product release notes.	<a href="http://rok.auto/pcdc">rok.auto/pcdc</a>

## Documentation Feedback

Your comments help us serve your documentation needs better. If you have any suggestions on how to improve our content, complete the form at [rok.auto/docfeedback](http://rok.auto/docfeedback).



## Waste Electrical and Electronic Equipment (WEEE)



At the end of life, this equipment should be collected separately from any unsorted municipal waste.

Rockwell Automation maintains current product environmental compliance information on its website at [rok.auto/pec](http://rok.auto/pec).

Rockwell Otomasyon Ticaret A.Ş. Kar Plaza İş Merkezi E Blok Kat:6 34752 İçerenköy, İstanbul, Tel: +90 (216) 5698400 EEE Yönetmeliğine Uygundur

Connect with us.    

**rockwellautomation.com** — expanding **human possibility**<sup>®</sup>

AMERICAS: Rockwell Automation, 1201 South Second Street, Milwaukee, WI 53204-2496 USA, Tel: (1) 414.382.2000, Fax: (1) 414.382.4444

EUROPE/MIDDLE EAST/AFRICA: Rockwell Automation NV, Pegasus Park, De Kleetlaan 12a, 1831 Diegem, Belgium, Tel: (32) 2663 0600, Fax: (32) 2 663 0640

ASIA PACIFIC: Rockwell Automation SEA Pte Ltd, 2 Corporation Road, #04-05, Main Lobby, Corporation Place, Singapore 618494, Tel: (65) 6510 6608, FAX: (65) 6510 6699

UNITED KINGDOM: Rockwell Automation Ltd., Pitfield, Kiln Farm, Milton Keynes, MK11 3DR, United Kingdom, Tel: (44)(1908) 838-800, Fax: (44)(1908) 261-917

Allen-Bradley, ControlLogix, ControlLogix-XT, expanding human possibility, and Rockwell Automation are trademarks of Rockwell Automation, Inc.

EtherNet/IP is a trademark of ODVA, Inc.

Trademarks not belonging to Rockwell Automation are property of their respective companies.



PN-738324

Publication 1756-IN043G-EN-P - July 2025 | Supersedes Publication 1756-IN043F-EN-P - June 2024

Copyright © 2025 Rockwell Automation, Inc. All rights reserved. Printed in the U.S.A.

PN-738324