



## POINT I/O Cold Junction Compensation Wiring Base Assembly

Catalog Numbers 1734-TBCJC

### Summary of Changes

This publication contains the following new or updated information. This list includes substantive updates only and is not intended to reflect all changes.

Topic	Page
Updated template	throughout
Updated the Prepare the Wires section	1
Added the Wire the RTB section	2
Updated Specifications	2
Added Additional Resources	2

### Environment and Enclosure



**ATTENTION:** This equipment is intended for use in a Pollution Degree 2 industrial environment, in overvoltage Category II applications (as defined in EN/IEC 60664-1), at altitudes up to 2000 m (6562 ft) without derating.

This equipment is supplied as open-type equipment for indoor use. It must be mounted within an enclosure that is suitably designed for those specific environmental conditions that will be present and appropriately designed to help prevent personal injury resulting from accessibility to live parts. The enclosure must have suitable flame-retardant properties to help prevent or minimize the spread of flame, complying with a flame spread rating of SVA or be approved for the application if nonmetallic. The interior of the enclosure must be accessible only by the use of a tool. Subsequent sections of this publication may contain more information regarding specific enclosure type ratings that are required to comply with certain product safety certifications.

In addition to this publication, see the following:

- Industrial Automation Wiring and Grounding Guidelines, publication [1770-4.1](#), for additional installation requirements.
- NEMA Standard 250 and EN/IEC 60529, as applicable, for explanations of the degrees of protection provided by different types of enclosure.

### Prevent Electrostatic Discharge



**ATTENTION:** This equipment is sensitive to electrostatic discharge, which can cause internal damage and affect normal operation. Follow these guidelines when you handle this equipment:

- Touch a grounded object to discharge potential static.
- Wear an approved grounding wriststrap.
- Do not touch connectors or pins on component boards.
- Do not touch circuit components inside the equipment.
- Use a static-safe workstation if available.
- Store the equipment in appropriate static-safe packaging when not in use.
- This equipment is certified for use only within the surrounding air temperature range of -20...+55 °C (-4...+131 °F). The equipment must not be used outside of this range.
- Use only a soft dry anti-static cloth to wipe down equipment. Do not use any cleaning agents.



#### ATTENTION:

- If this equipment is used in a manner that is not specified by the manufacturer, the protection that is provided by the equipment may be impaired.
- Read this document and the documents listed in the Additional Resources section about installation, configuration, and operation of this equipment before you install, configure, operate, or maintain this product. Users are required to familiarize themselves with installation and wiring instructions in addition to requirements of all applicable codes, laws, and standards.
- Installation, adjustments, putting into service, use, assembly, disassembly, and maintenance are required to be carried out by suitably trained personnel in accordance with applicable code of practice.
- In case of malfunction or damage, no attempts at repair should be made. The module should be returned to the manufacturer for repair. Do not dismantle the module.
- This equipment is certified for use only within the surrounding air temperature range of -20...+55 °C (-4...+131 °F). The equipment must not be used outside of this range.
- Use only a soft dry anti-static cloth to wipe down equipment. Do not use any cleaning agents.

### About the Assembly

The POINT I/O™ cold junction compensation wiring base assembly consists of a mounting base (MB) and a removable terminal block (RTB) - The 1734-TBCJC assembly wiring base (1734-MB + 1734-RTB) uses screw-clamp terminations.

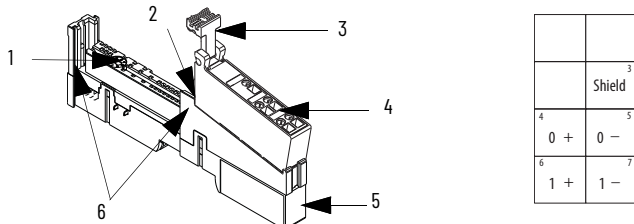

For use with a 1734-IT21 POINT I/O thermocouple input module.

#### Component Description

	Description		Description
1	Mechanical keying (orange)	4	RTB
2	DIN rail locking screw (orange)	5	MB
3	RTB removal handle	6	Interlocking side pieces

### Prepare the Wires

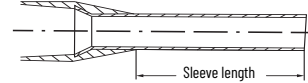
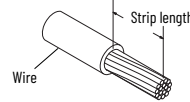

### Wiring without Wire End Ferrule

Catalog Number	Wire Size Range	Number of Wires	Strip Length
			5-position RTB
1734-RTB/CJC	0.08...2.5 mm <sup>2</sup> (28...14 AWG)	1	14 ± 1 mm (0.55 ± 0.03 in.)
	0.75 mm <sup>2</sup> (18 AWG)	2 <sup>(1)</sup>	16 ± 1 mm (0.63 ± 0.03 in.)

(1) For two wires per cavity, only stranded wire can be used.

### Wiring with Wire End Ferrule

Catalog Number	Wire Size Range <sup>(1)</sup>	Number of Wires	Strip Length <sup>(2)</sup>	Sleeve Length <sup>(3)(4)</sup>
			5-position RTB	
1734-RTB/CJC	0.50...1.0 mm <sup>2</sup> (20...17 AWG)	1	12.5 ± 0.4 mm (0.49 ± 0.016 in.)	10 mm (0.393 in.)

(1) Wire size < 0.325 mm<sup>2</sup> (22 AWG) is not included in the DIN 46228-4 standard.

(2) Ferrule stripping length: See the ferrule manufacturer's guidelines to determine the actual wire stripping length. Ensure that the tolerance does not exceed ± 0.4 mm (± 0.016 in.) or follow the manufacturer's specified range if it is smaller.

(3) TWIN wire end ferrules are not recommended for wiring.

(4) Recommended wire end Ferrule with insulating collar, in accordance with DIN 46228-4 and UL 486F.



**ATTENTION:** Do not wire more than 2 conductors on any single terminal.

### Install the Mounting Base

To install the mounting base on the DIN rail (Allen-Bradley® part number 199-DR1; 46277-3; EN50022), proceed as follows:



**ATTENTION:** This product is grounded through the DIN rail to chassis ground. Use zinc-plated chromate-passivated steel DIN rail to assure proper grounding. The use of other DIN rail materials (for example, aluminum or plastic) that can corrode, oxidize, or are poor conductors, can result in improper or intermittent grounding. Secure DIN rail to mounting surface approximately every 200 mm (7.8 in.) and use end-anchors appropriately. Be sure to ground the DIN rail properly. See Industrial Automation Wiring and Grounding Guidelines, Rockwell Automation publication [1770-4.1](#), for more information.

- Position the mounting base vertically above the installed units (adapter, power supply, or existing module).
- Slide the mounting base down allowing the interlocking side pieces to engage the adjacent module or adapter.
- Press firmly to seat the mounting base on the DIN rail. The mounting base snaps into place.

### Install the Removable Terminal Block

An RTB is supplied with your wiring base assembly. To remove, pull up on the RTB handle. This allows the mounting base to be removed and replaced as necessary without removing any wiring. To reinsert the RTB, proceed as follows:

- Insert the end opposite the handle into the base unit. This end has a curved section that engages with the wiring base.
- Rotate the terminal block into the wiring base until it locks itself in place.
- If an I/O module is installed, snap the RTB handle into place on the module.

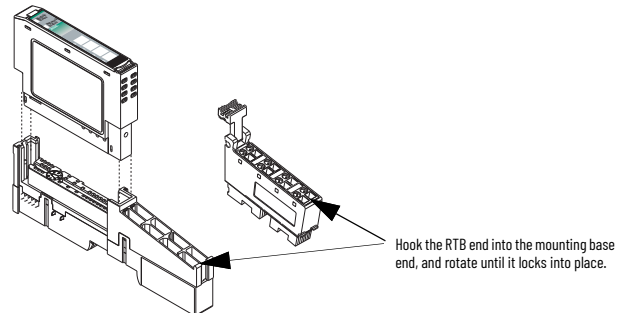

## Wire the Screw-type RTB

To insert a wire into the screwclamp RTB, proceed as follows:

1. Insert a bladed screwdriver into the embedded screw and turn it counterclockwise to open the wire entry locator.  
Do not exceed the torque specification in [General Specifications](#).
2. Insert the wire into the RTB and turn the screwdriver clockwise to tighten the screw clamp.

## Remove a Mounting Base

To remove a mounting base, you must remove any installed module, and the module installed in the base to the right. Remove the RTB (if wired).



**ATTENTION:** Do not remove or replace a terminal base unit while power is applied. Interruption of the backplane can result in unintentional operation or machine motion.



**WARNING:** Do not disconnect or replace component unless power is switched off or area is known to be nonhazardous. Do not pull on the installed wiring to remove a terminal base. A shock hazard exists if power is applied to the terminal base.

1. Unlatch the RTB handle on the I/O module.
2. Pull on the RTB handle to remove the RTB.
3. Press the module lock on the top of the module and pull on the I/O module to remove from the base.
4. Repeat steps 1...3 for the module to the right.
5. Use a small bladed screwdriver to rotate the orange base locking screw to a vertical position. This releases the locking mechanism.
6. Lift the mounting base straight up to remove.

## Specifications

### General Specifications

Attribute	Value
RTB screw torque	0.5...0.6 N·m (5...7 lb-in)
Supply voltage, max	28.8V DC 120/240V AC
Supply current, max	10 A
Dimensions (HxWxD), approx.	65 x 12 x 133.4 mm (2.56 x 0.47 x 5.25 in.)
Weight approx.	97.5 g (3.44 oz.)
Wire category <sup>(1)(2)</sup>	2 - on signal ports
Wire size	See <a href="#">Wiring without Wire End Ferrule</a> and <a href="#">Wiring with Wire End Ferrule</a> tables for wire size. Use Thermocouple wire with 1.2 mm (3/64 in.) thickness insulation max.
Enclosure type rating	None (open-style)

- (1) Use this conductor category information for planning conductor routing as described in Industrial Automation Wiring and Grounding Guidelines, publication [I734-5600](#).  
 (2) Use this conductor category information for planning conductor routing as described in the appropriate System Level Installation Manual.

### Environmental Specifications

Attribute	Value
Temperature, operating	IEC 60068-2-1 (Test Ad, Operating Cold), IEC 60068-2-2 (Test Bd, Operating Dry Heat), IEC 60068-2-14 (Test Nb, Operating Thermal Shock); -20 °C ≤ Ta ≤ +55 °C (-4 °F ≤ Ta ≤ +131 °F)
Temperature, surrounding air, max	55 °C (131 °F)
Temperature, nonoperating	IEC 60068-2-1 (Test Ab, Unpackaged Nonoperating Cold), IEC 60068-2-2 (Test Bb, Unpackaged Nonoperating Dry Heat), IEC 60068-2-14 (Test Nb, Unpackaged Nonoperating Thermal Shock); -40...+85 °C (-40...+185 °F)
Relative humidity	IEC 60068-2-30 (Test Db, Unpackaged Damp Heat): 5...95% noncondensing
Vibration	IEC 60068-2-6 (Test Fc, Operating): 5 g @ 10...500 Hz
Shock, operating	IEC 60068-2-27 (Test Ea, Unpackaged Shock): 30 g
Shock, nonoperating	IEC 60068-2-27 (Test Ea, Unpackaged Shock): 50 g

### Certifications

Certifications (when the product is marked) <sup>(1)</sup>	Value
c-UR-us	UL Recognized Component Industrial Control Equipment, certified for US and Canada. See UL File E185367.
UK and CE	UK Statutory Instrument 2016 No. 1101 and European Union 2014/35/EU LVD, compliant with: EN 6131-2: Programmable Controllers (Clause 11) UK Statutory Instrument 2012 No. 3032 and European Union 2011/65/EU RoHS, compliant with: EN IEC 63000: Technical documentation
Morocco	Arrêté ministériel n° 6404-15 du 1 er muharram 1437

- (1) See the Product Certifications link at [rok.auto/certifications](#) for Declarations of Conformity, Certificates, and other certification details.

## Additional Resources

For more information on the products that are described in this publication, use these resources. You can view or download publications at [rok.auto/literature](#).

Resource	Description
POINT I/O Modules Selection Guide, publication <a href="#">I734-5600</a>	Provides information on how to select POINT I/O adapters, terminal bases, I/O modules, and accessories.
Industrial Automation Wiring and Grounding Guidelines, publication <a href="#">I770-4.1</a>	More information on proper wiring and grounding techniques.
Product Certifications website, <a href="#">rok.auto/certifications</a>	Provides declarations of conformity, certificates, and other certification details.

## Rockwell Automation Support

Use these resources to access support information.

<b>Technical Support Center</b>	Find help with how-to videos, FAQs, chat, user forums, Knowledgebase, and product notification updates.	<a href="#">rok.auto/support</a>
<b>Local Technical Support Phone Numbers</b>	Locate the telephone number for your country.	<a href="#">rok.auto/phonesupport</a>
<b>Technical Documentation Center</b>	Quickly access and download technical specifications, installation instructions, and user manuals.	<a href="#">rok.auto/techdocs</a>
<b>Literature Library</b>	Find installation instructions, manuals, brochures, and technical data publications.	<a href="#">rok.auto/literature</a>
<b>Product Compatibility and Download Center (PCDC)</b>	Download firmware, associated files (such as AOP, EDS, and DTM), and access product release notes.	<a href="#">rok.auto/pcdc</a>

## Documentation Feedback

Your comments help us serve your documentation needs better. If you have any suggestions on how to improve our content, complete the form at [rok.auto/docfeedback](#).





## Waste Electrical and Electronic Equipment (WEEE)



At the end of life, this equipment should be collected separately from any unsorted municipal waste.

Rockwell Automation maintains current product environmental compliance information on its website at [rok.auto/pec](#).

Rockwell Otomasyon Ticaret A.Ş. Kar Plaza İş Merkezi E Blok Kat:6 34752, İçerenköy, İstanbul, Tel: +90 (216) 5698400 EEE Yönetmeliğine Uygundur

Connect with us.    

[rockwellautomation.com](#)

expanding human possibility®

AMERICAS: Rockwell Automation, 1201 South Second Street, Milwaukee, WI 53204-2496 USA, Tel: (1) 414.382.2000

EUROPE/MIDDLE EAST/AFRICA: Rockwell Automation NV, Pegasus Park, De Kleetlaan 12a, 1831 Diegem, Belgium, Tel: (32) 2663 0600

ASIA PACIFIC: Rockwell Automation SEA Pte Ltd, 2 Corporation Road, #04-05, Main Lobby, Corporation Place, Singapore 618494, Tel: (65) 6510 6608

UNITED KINGDOM: Rockwell Automation Ltd., Pitfield, Kiln Farm, Milton Keynes, MK11 3DR, United Kingdom, Tel: (44)(1908) 838-800

Allen-Bradley, expanding human possibility, POINT I/O, Rockwell Automation, and TechConnect are trademarks of Rockwell Automation, Inc.

Trademarks not belonging to Rockwell Automation are property of their respective companies.

Publication 1734-IN583F-EN-P - June 2025 | Supersedes Publication 1734-IN583E-EN-P - December 2024

Copyright © 2025 Rockwell Automation, Inc. All rights reserved. Printed in China.

PN-755742