

# RIGOL DHO900 Digital Oscilloscope User Guide



## RIGOL DHO900 Digital Oscilloscope



### Specifications

- **Manufacturer:** RIGOL
- **Standards Conformance:** ISO9001:2015, ISO14001:2015

### Product Usage Instructions

### Safety Requirements

Please review the following safety precautions carefully before putting the instrument into operation to avoid personal injury or damage to the instrument and connected products.

1. Use only the exclusive power cord designed for the instrument.
2. Ensure proper grounding of the instrument.
3. Observe all terminal ratings.
4. Use proper overvoltage protection.
5. Do not operate without covers.
6. Avoid inserting objects into the air outlet.
7. Avoid circuit or wire exposure.
8. Do not operate the instrument with suspected failures.

9. Provide adequate ventilation.
10. Avoid operating in wet conditions or explosive atmospheres.
11. Keep instrument surfaces clean and dry.
12. Avoid electrostatic impact.

### **Ventilation Requirement**

- This instrument uses a fan for cooling. Ensure the air inlet and outlet areas are free from obstructions and have free air.
- Provide at least 10 cm clearance beside, above, and behind the instrument for adequate ventilation. Inadequate ventilation may cause damage to the instrument.

### **Working Environment**

#### **Temperature:**

- **Operating:** 0 to +50 degrees Celsius
- **Non-operating:** -30 to +60 degrees Celsius
- **Humidity:** To avoid short circuits or electric shock, do not operate the instrument in a humid environment.

### **Frequently Asked Questions**

#### **Q: How can I ensure proper grounding of the instrument?**

**A:** Use only the exclusive power cord designed for the instrument and make sure it is grounded as per safety guidelines.

#### **Q: What should I do if I suspect a failure in the instrument?**

**A:** Do not operate the instrument and contact RIGOL for assistance and possible repair.

#### **Q: Can I operate the instrument in wet conditions?**

**A:** No, avoid operating the instrument in wet conditions to prevent damage and ensure safety.

### **Guaranty and Declaration**

#### **Copyright**

- © 2024 RIGOL TECHNOLOGIES CO., LTD. All Rights Reserved.

#### **Trademark Information**

- RIGOL® is the trademark of RIGOL TECHNOLOGIES CO., LTD.

#### **Software Version**

- Software upgrades might change or add product features. Please acquire the latest software version from the RIGOL website or contact RIGOL to upgrade the software.

#### **Notices**

- RIGOL products are covered by P.R.C. and foreign patents, issued and pending.
- RIGOL reserves the right to modify or change parts of or all the specifications and pricing policies at the company's sole decision.
- Information in this publication replaces all previously released materials.
- Information in this publication is subject to change without notice.
- RIGOL shall not be liable for either incidental or consequential losses in connection with the furnishing,

use, or performance of this manual, as well as any information contained.

- Any part of this document is forbidden to be copied, photocopied, or rearranged without prior written approval of RIGOL.

## Product Certification

- RIGOL guarantees that this product conforms to the national and industrial standards in China as well as the ISO9001:2015 standard and the ISO14001:2015 standard. Other international standard conformance certifications are in progress.

## Contact Us

- If you have any problem or requirement when using our products or this manual, please contact RIGOL.
- **E-mail:** [service@rigol.com](mailto:service@rigol.com)
- **Website:** <http://www.rigol.com>

## Safety Requirement

### General Safety Summary

- Please review the following safety precautions carefully before putting the instrument into operation to avoid any personal injury or damage to the instrument and any product connected to it.
  - To prevent potential hazards, please follow the instructions specified in this manual to use the instrument properly.
1. Only the exclusive power cord designed for the instrument and authorized for use within the destination country could be used.
  2. Ensure that the instrument is safely grounded.
  3. Observe all terminal ratings.
  4. Use proper overvoltage protection.
  5. Do not operate without covers.
  6. Do not insert objects into the air outlet.
  7. Avoid circuit or wire exposure.
  8. Do not operate the instrument with suspected failures.
  9. Provide adequate ventilation.
  10. Do not operate in wet conditions.
  11. Do not operate in an explosive atmosphere.
  12. Keep instrument surfaces clean and dry.
  13. Prevent electrostatic impact.
  14. Handle with caution.

**WARNING** Equipment meeting Class A requirements may not offer adequate protection to broadcast services within a residential environment.

### Safety Notices and Symbols

- **WARNING** Indicates a potentially hazardous situation or practice which, if not avoided, will result in serious injury or death.
- **CAUTION** Indicates a potentially hazardous situation or practice which, if not avoided, could result in damage to the product or loss of important data.

### Safety Notices on the Product:

- **DANGER** It calls attention to an operation that, if not correctly performed, could result in injury or hazard immediately.
- **WARNING** It calls attention to an operation that, if not correctly performed, could result in potential injury or hazard.

- **CAUTION** It calls attention to an operation that, if not correctly performed, could result in damage to the product or other devices connected to the product.

### Safety Symbols on the Product:



### Measurement Category

- This instrument can make measurements in Measurement Category I.
- **WARNING** This instrument can only be used for measurements within its specified measurement categories.

### Measurement Category Definitions

- Measurement category I is for measurements performed on circuits not directly connected to MAINS. Examples are measurements on circuits not derived from MAINS and specially protected (internal) MAINS-derived circuits.
- In the latter case, transient stresses are variable. Thus, you must know the transient withstand capability of the equipment.
- Measurement category II is for measurements performed on circuits directly connected to low-voltage installation. Examples are measurements on household appliances, portable tools, and similar equipment.
- Measurement category III is for measurements performed in the building installation.
- Examples are measurements on distribution boards, circuit breakers, wiring (including cables, bus bars, junction boxes, switches, and socket outlets) in the fixed installation, equipment for industrial use, and some other equipment.
- For example, stationary motors with a permanent connection to a fixed installation.
- Measurement category IV is for measurements performed at the source of a low-voltage installation. Examples are electricity meters and measurements on primary overcurrent protection devices and ripple control units.

### Ventilation Requirement

- This instrument uses a fan to force cooling. Please make sure that the air inlet and outlet areas are free from obstructions and have free air.
- When using the instrument in a bench-top or rack setting, provide at least 10 cm clearance beside, above, and behind the instrument for adequate ventilation.
- **CAUTION** Inadequate ventilation may cause an increase in temperature in the instrument, which would cause damage to the instrument.
- So please keep the instrument well-ventilated and inspect the air outlet and the fan regularly.

### Working Environment

#### Temperature

- **Operating:** 0°C to +50°C
- **Non-operating:** -30°C to +60°C

#### Humidity

#### Operating:

- **Below +30°C:** ≤90%RH (without condensation)
- **+30°C to +40°C:** ≤75% RH (without condensation)
- **+40°C to +50°C:** ≤45%RH (without condensation)

## Non-operating:

- Below +60°C: ≤90%RH (without condensation)
- **WARNING** To avoid short circuits inside the instrument or electric shock, never operate the instrument in a humid environment.

## Altitude

- **Operating:** below 3 km
- **Non-operating:** below 15 km

## Protection Level Against Electric Shock

- ESD ±8kV

## Installation (Overvoltage) Category

- This product is powered by mains conforming to installation (overvoltage) category II.
- **WARNING** Ensure that no overvoltage (such as that caused by a bolt of lightning) can reach the product. Otherwise, the operator might be exposed to the danger of an electric shock.

## Installation (Overvoltage) Category Definitions

- **Installation (overvoltage) category I** refers to a signal level that applies to equipment measurement terminals connected to the source circuit. Among these terminals, precautions are taken to limit the transient voltage to a low level.
- Installation (overvoltage) category II refers to the local power distribution level which applies to equipment connected to the AC line (AC power).

## Pollution Degree

- Pollution Degree 2

## Pollution Degree Definition

- **Pollution Degree 1:** No pollution or only dry, nonconductive pollution occurs.
- The pollution has no effect. For example, a clean room or air-conditioned office environment.
- **Pollution Degree 2:** Normally only nonconductive pollution occurs. Temporary conductivity caused by condensation is to be expected. For example, indoor environment.
- **Pollution Degree 3:** Conductive pollution or dry nonconductive pollution that becomes conductive due to condensation occurs. To be found in industrial environments or construction sites (harsh environments).
- For example, a sheltered outdoor environment.
- **Pollution Degree 4:** The pollution generates persistent conductivity caused by conductive dust, rain, or snow. For example, outdoor areas.

## Safety Class

- Class 2

## Care and Cleaning

### Care

- Do not store or leave the instrument where it may be exposed to direct sunlight for long periods.

### Cleaning

Clean the instrument regularly according to its operating conditions.

1. Disconnect the instrument from all power sources.
  2. Clean the external surfaces of the instrument with a soft cloth dampened with mild detergent or water. Avoid having any water or other objects in the chassis via the heat dissipation hole. When cleaning the LCD, take care to avoid scarifying it.
- **CAUTION** To avoid damage to the instrument, do not expose it to caustic liquids.
  - **WARNING** To avoid short-circuits resulting from moisture or personal injuries, ensure that the instrument is completely dry before connecting it to the power supply.

## Environmental Considerations

- The following symbol indicates that this product complies with the WEEE Directive 2002/96/EC.
- The equipment may contain substances that could be harmful to the environment or human health. To avoid the release of such substances into the environment and avoid harm to human health, we recommend you recycle this product appropriately to ensure that most materials are reused or recycled properly. Please contact your local authorities for disposal or recycling information.
- You can click on the following link <https://int.rigol.com/services/services/declaration> to download the latest version of the RoHS&WEEE certification file.

## Document Overview

- This manual gives you a quick overview of the front and rear panels, user interface as well as basic operation methods of the DHO900 series.

## TIP

- For the latest version of this manual, download it from RIGOL's official website (<http://www.rigol.com>).

## Publication number

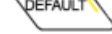
- QGA37102-1110

## Software Version

- Software upgrades might change or add product features. Please acquire the latest version of the manual from the RIGOL website or contact RIGOL to upgrade the software.

## Format Conventions in this Manual



### 1. Key

- The front panel key is denoted by the menu key icon. For example,  indicates the "Default" key.

### 2. Menu

- The menu item is denoted by the format of "Menu Name (Bold) + Character Shading" in the manual. For example, Setup indicates the "Setup" sub-menu under the "Utility" function menu. You can click or tap Setup to access the "Setup" menu.

### 3. Operation Procedures

- The next step of the operation is denoted by ">" in the manual. For example,  > Storage indicates first clicking or tapping  and then clicking or tapping Storage.

### 4. Connector

- The front/rear panel connector is denoted by "Brackets + Connector Name (Bold)", for example, [AUX OUT].

## Content Conventions in this Manual

- DHO900 series digital oscilloscope includes the following models. Unless otherwise specified, this manual takes DHO924S as an example to illustrate the operation methods of the DHO900 series.

<b>Model</b>	<b>Max. Analog Bandwidth</b>	<b>No. of Analog Channels</b>
DHO914	125 MHz	4
DHO914S	125 MHz	4
DHO924	250 MHz	4
DHO924S	250 MHz	4

## **General Inspection**

### **1. Inspect the packaging**

- If the packaging has been damaged, do not dispose of the damaged packaging or cushioning materials until the shipment has been checked for completeness and has passed both electrical and mechanical tests.
- The consigner or carrier shall be liable for the damage to the instrument resulting from shipment. RIGOL would not be responsible for free maintenance/rework or replacement of the instrument.

### **2. Inspect the instrument**

- In case of any mechanical damage, missing parts, or failure in passing the electrical and mechanical tests, contact your RIGOL sales representative.

### **3. Check the accessories**

- Please check the accessories according to the packing lists. If the accessories are damaged or incomplete, please contact your RIGOL sales representative.

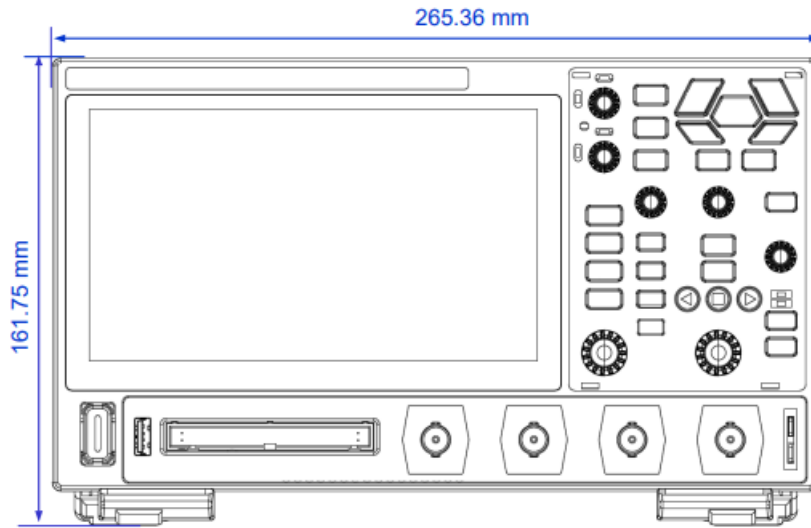
## **Recommended Calibration Interval**

RIGOL suggests that the instrument should be calibrated every 18 months.

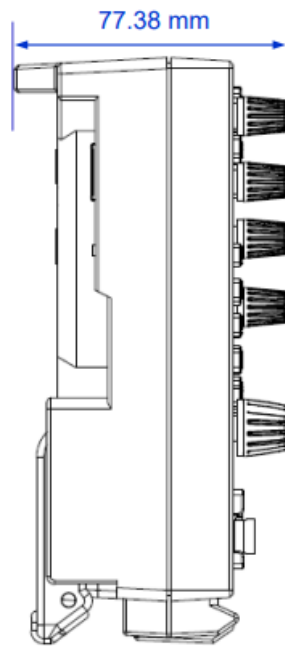
## **Product Overview**

- RIGOL introduces the brand new DHO900 series economy oscilloscope into its oscilloscope family.
- With a compact size, the DHO900 series achieves a waveform capture rate of 1,000,000 wfms/s with the UltraAcquire mode, 50 Mpts memory depth, 12-bit resolution, and low noise.

## **Appearance and Dimensions**

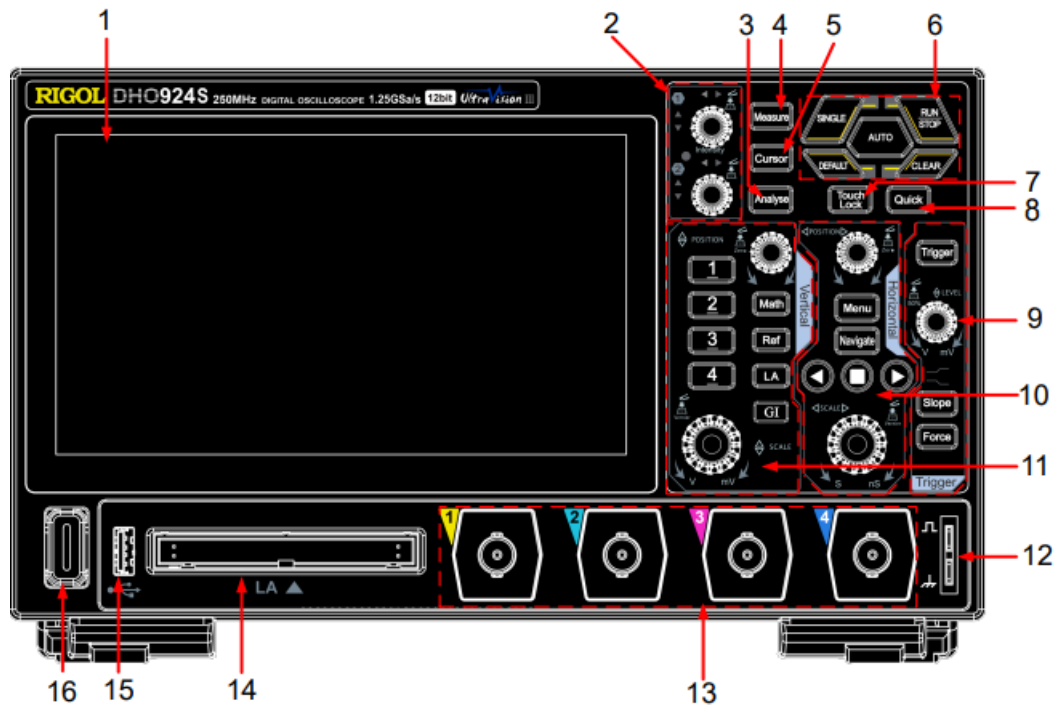


**Figure 4.1 Front View**



**Figure 4.2 Side View**

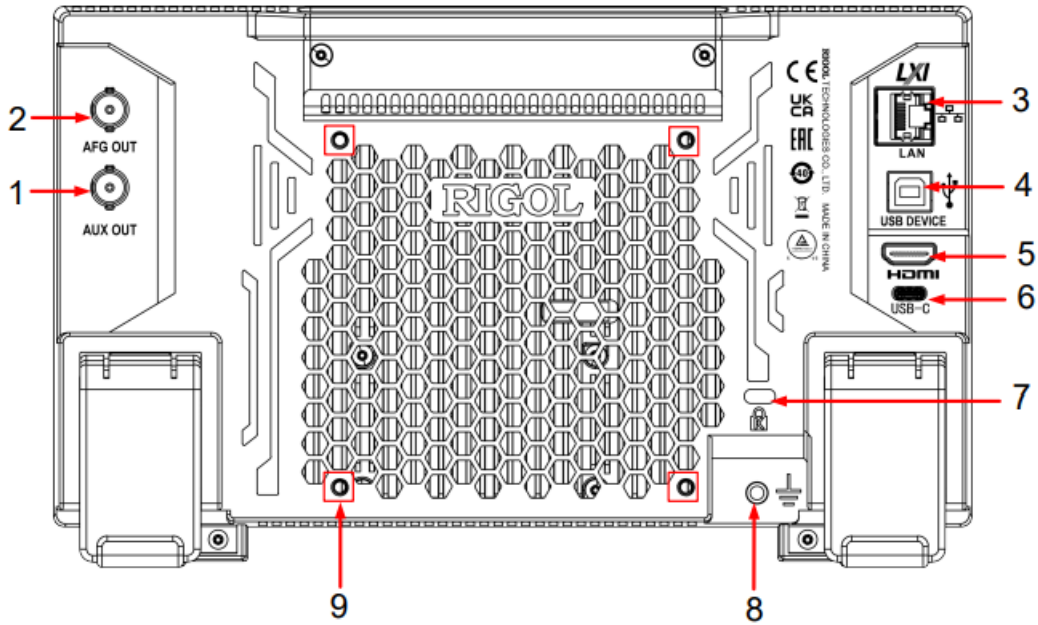
Front Panel Overview



**Figure 4.3 Front Panel**

1. 7" Capacitive Touch Screen
2. Multipurpose Knobs
3. Analyse Key
4. Measure Key
5. Cursor Key
6. Common Tools Keys
7. Touch Lock Key
8. Quick Action Key (Self-defined function)
9. Trigger Controls
10. Horizontal Controls
11. Vertical Controls
12. Probe Compensation Signal Output Terminal/Ground Terminal
13. Analog Channel Input Terminals.
14. Digital Channel Input Terminal
15. USB HOST Port
16. Power Key

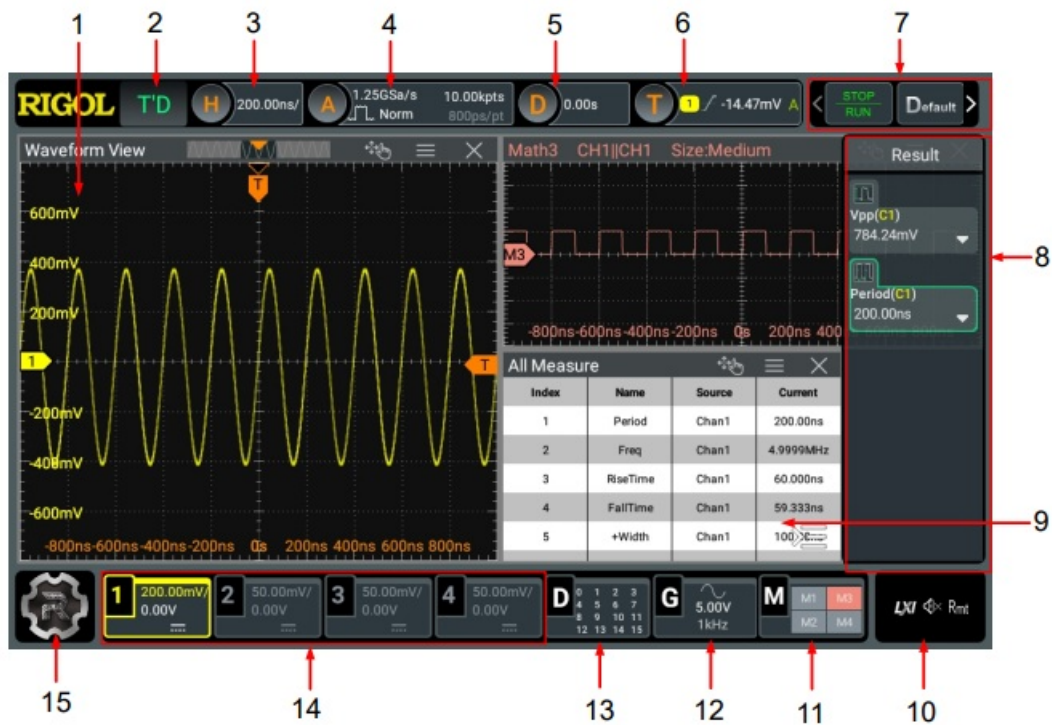
### Rear Panel Overview



**Figure 4.4 Rear Panel**

1. AUX OUT Interface
2. AFG OUT Interface (for DHO914S and DHO924S only)
3. LAN Port
4. USB DEVICE Port
5. HDMI Connector
6. USB Type-C Power Connector
7. Security Lock Hole
8. Ground Terminal
9. Mounting Screws (VESA 100 x 100)

**User Interface Overview**



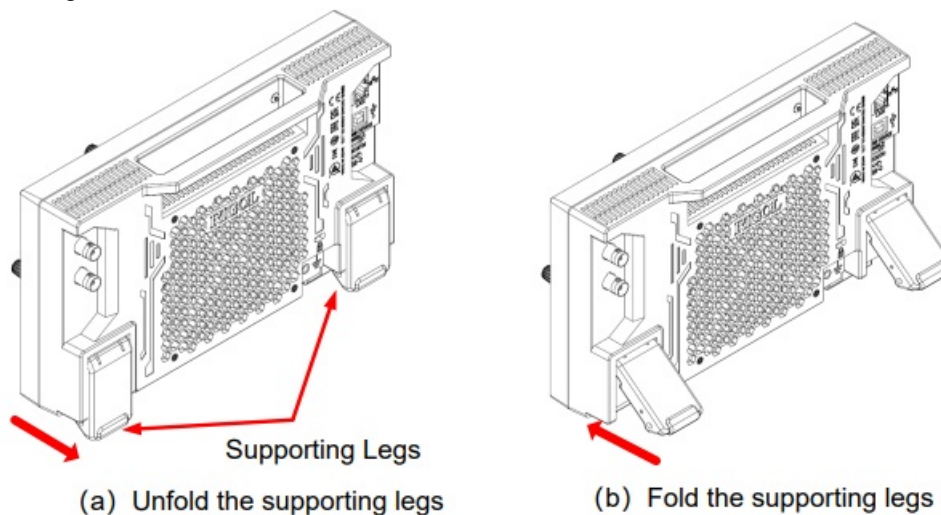
**Figure 4.5 User Interface**

1. Waveform View
2. Run State Label
3. Horizontal Timebase Label
4. Sample Rate & Memory Depth Label
5. Horizontal Position Label
6. Trigger Label
7. Function Toolbar
8. Result Sidebar
9. Split-screen Display
10. Notification Area
11. Math Labels
12. AFG Label (for DHO914S and DHO924S only)
13. Logic Analyzer Label
14. Channel Labels
15. Function Navigation Icon

## To Prepare for Use

### To Adjust the Supporting Legs

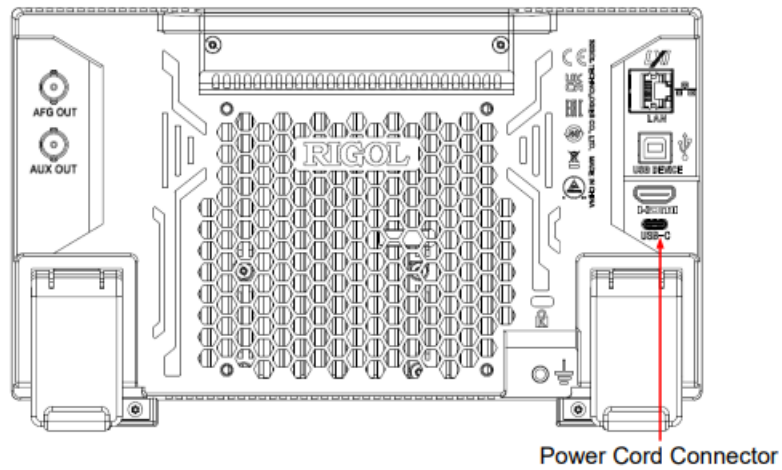
- Adjust the supporting legs properly to use them as stands to tilt the oscilloscope upwards for stable placement of the oscilloscope as well as better operation and observation.
- You can also fold the supporting legs when the instrument is not in use for easier storage or shipment, as shown in the figure below.



**Figure 5.1 Adjusting the Supporting Legs**

### To Connect to Power

- The power requirements of the oscilloscope are DC, 12 V, 4 A. Please use the power adaptor provided in the accessories to connect the oscilloscope to the AC power source (100 V to 240 V, 50 Hz to 60 Hz), as shown in the figure below.



**Figure 5.2 To Connect to Power**

**Table 5.1 Power Adaptor Specifications**

Item	Description
Input	100 V to 240 V, 50 Hz to 60 Hz, 1.2 A Max
Output	DC, 12 V, 4 A, 48 W



**CAUTION**

- The power adaptor provided in accessories can only be used to power RIGOL instruments.
- Do not use it for mobile phones and other devices.





**WARNING**

- To avoid electric shock, ensure that the instrument is correctly grounded.


**Turn-on Checkout**

- After the instrument is connected to the power source, press the power key  at the lower-left corner of the front panel to power the instrument.
- During the start-up process, the instrument performs a series of self-tests. After the self-test, the splash screen is displayed.
- **Restart:** Click or tap  > Restart. Then a prompt message “Are you sure to reboot?” is displayed. Click or tap OK to restart the instrument.


**Shutdown:**

- Click or tap  > Shutdown. Then a prompt message “Are you sure to shut down?” is displayed. Click or tap OK to shut down the instrument.
- Press  and a prompt message “Are you sure to shutdown?” is displayed.
- Click or tap OK to shut down the instrument.
- Press  twice to shut down the instrument.
- Press  for three seconds to shut down the instrument.

**TIP**

- You can also click or tap  > Utility > Setup and set the “Power status” to “Switch on”. The instrument powers once connected to power.

### To Set the System Language

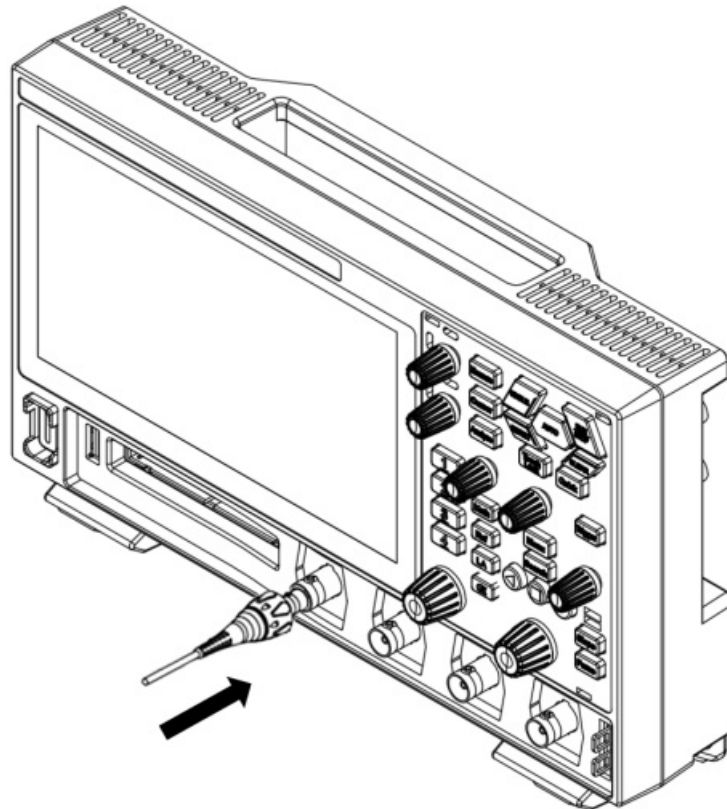
- This oscilloscope supports multiple languages. You can click or tap  > Utility > Setup > Language to select the system language.

### To Connect the Probe

- RIGOL provides passive probes and logic probes (optional) for the DHO900 series. For specific probe models, refer to the DHO900 Data Sheet. For detailed technical information on the probes, please refer to the corresponding Probe User Guide.

### Connect the Passive Probe

1. Connect the BNC terminal of the probe to an analog channel input terminal of the oscilloscope on the front panel as shown in the figure below.
2. Connect the ground alligator clip or spring of the probe to the circuit ground terminal, and then connect the probe tip to the circuit point to be tested.

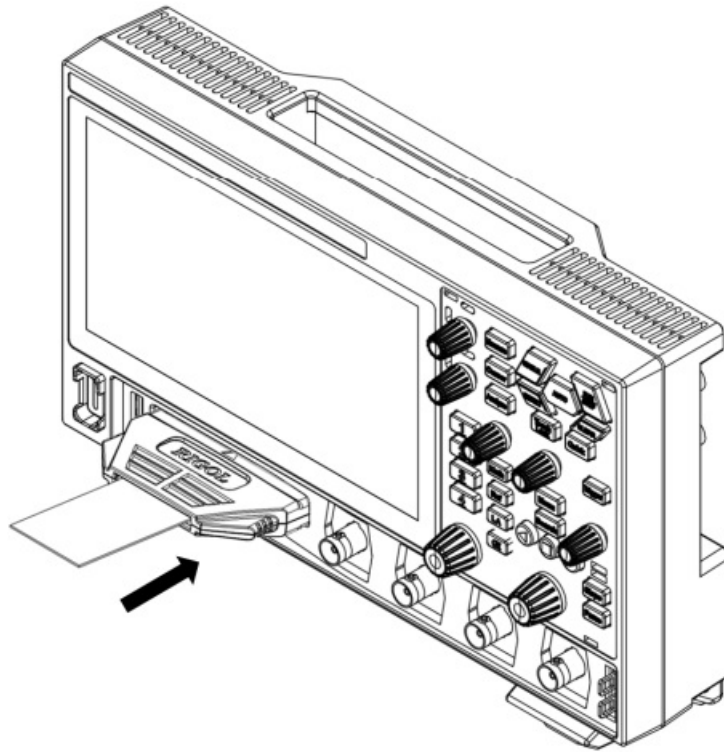


**Figure 5.3 Connecting the Passive Probe**

After you connect the passive probe, check the probe function and probe compensation adjustment before making measurements. For details, please refer to Function Inspection and Probe Compensation.

### Connect the Logic Probe


1. Connect the output terminal of the logic probe to the digital channel input terminal on the front panel of the oscilloscope in the correct direction, as shown in the figure below.
2. Connect the other terminal of the logic probe to the signal terminal under test.
  - DHO900 provides the optional PLA2216 active logic probe. To cater to different application scenarios, PLA2216 provides two methods to connect the signal under test. For details, refer to

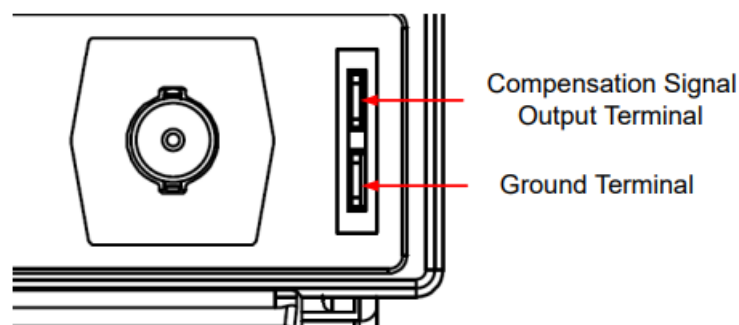


**Figure 5.4 Connecting the Logic Probe**


- **CAUTION** The digital channel input terminal does not support hot plugging. Do not insert or pull out the logic probe when the instrument is in a power-on state.
- **TIP** For ground connection of high-speed signals, the ground lead shall be connected to the ground test point near the measured signal, and the ground lead shall be kept as short as possible.
- If there are a large number of input signal channels, please connect each signal to a ground signal as far as possible. If there is only one ground test point, connect all ground leads on the probe to the ground test point.
- Set the threshold value of the logic probe reasonably according to the actual level range of the measured signal, and set the threshold value in the middle of the level range.

### Function Inspection

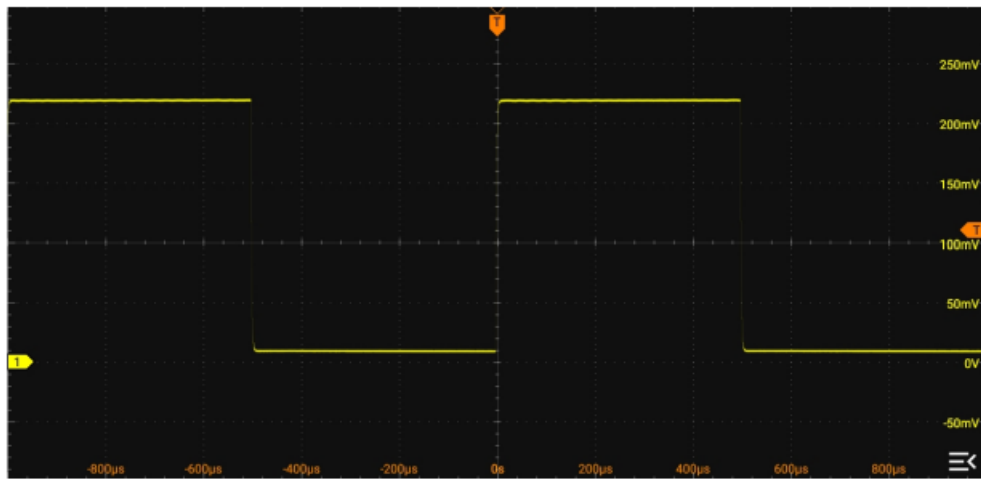
1. Press the front panel  and a prompt message “Restore default settings?” is displayed. Click or tap OK to restore the instrument to its factory default settings.
2. Connect the ground alligator clip of the probe to the “Ground Terminal” as shown in Figure 5.5.
3. Use the probe to connect the input terminal of CH1 and the “Compensation Signal Output Terminal” of the probe, as shown in Figure 5.5



**Figure 5.5 Using the Compensation Signal**

4. Set the probe ratio based on the attenuation of the probe, and then click or tap  > Auto.
5. Observe the waveform on the display. In normal conditions, you should see a square waveform similar

to the waveform shown in the figure below.



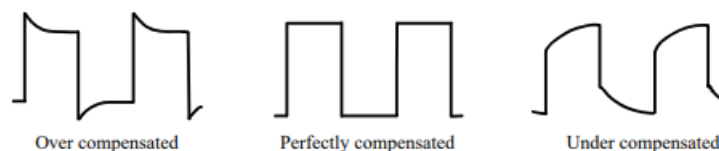
**Figure 5.6 Square Waveform Signal**

6. Test the other channels in the same way. If you see the waveform, but the square wave is not shaped correctly as shown above, perform the procedure described in Probe Compensation. If you do not see the waveform, perform those steps again.
- **WARNING** To avoid electric shock when using the probe, please make sure that the insulated wire of the probe is in good condition. Do not touch the metallic part of the probe when the probe is connected to the high-voltage source.

### Probe Compensation

When used for the first time, the oscilloscope probe must be compensated to match the input characteristics of the oscilloscope channel to which it is connected. The non-compensated or poorly compensated probe may cause measurement errors. The compensation procedure is as follows:

1. Perform Steps 1, 2, 3, and 4 in Function Inspection.
2. Check the displayed waveforms and compare them with the waveforms shown in Figure 5.7.



**Figure 5.7 Probe Compensation**

3. Use the probe compensation adjustment tool provided in the accessories to adjust the low-frequency compensation adjustment of the probe until the displayed waveform is consistent with the “Perfectly compensated” waveform shown in the above figure.

### Touch Screen Gestures

- The instrument’s large capacitive touch screen makes operation and configuration easy and flexible. The highly sensitive user interface designed for touch has a strong waveform display capability, bringing an extraordinary user experience.
- The actions supported by the touch screen controls include tapping, pinching&stretching, as well as dragging.

### Tap

- Use one finger to tap the symbol or characters on the screen slightly, as shown in Figure 6.1. With the Tap gesture, you can perform the following operations:
- Tap the menu displayed on the screen to operate on the menu.

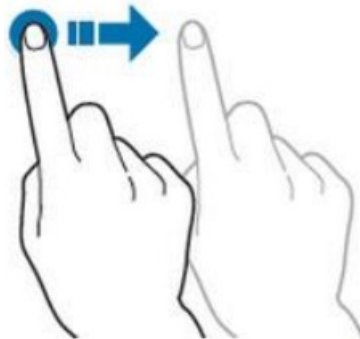
- Tap the function navigation icon at the lower-left corner of the touch screen to enable the function navigation.
- Tap the displayed numeric keypad to set the parameters.
- Tap the virtual keypad to set the label name and the filename.
- Tap the close button at the upper-right corner of the message box to close the prompt window.
- Tap other windows on the touch screen and operate on the windows.



**Figure 6.1 Tap Gesture**

### Drag

- Use one finger to select the object, and then drag the object to a destination place, as shown in the figure below. With the drag gesture, you can perform the following operation.
- Drag the waveform to change its position or scale.
- Drag the window controls to change the position of the window (e.g. numeric keypad).
- Drag the cursor to move the cursor.
- Drag the trigger cursor to change the trigger level.
- In a multi-window display, drag one of the displayed windows to change its position on the display.



**Figure 6.2 Drag Gesture**

### Pinch&Stretch


- Pinch or stretch two points on the screen with two fingers to zoom in or out the waveform. To zoom in on the waveform, first, pinch the two fingers and then stretch the fingers; to zoom out on the waveform, first stretch the two fingers, and then pinch the fingers together, as shown in the figure below. With the pinch and stretch gesture, you can perform the following operation.
- Pinching and stretching in the horizontal direction can adjust the horizontal time base of the waveform.
- Pinching and stretching in the vertical direction can adjust the vertical scale of the waveform.



**Figure 6.3 Pinch&Stretch Gesture**

### To Use the Built-in Help System

- The built-in help file provides information about the functions and menu introductions of the instrument.

Click or tap  > Help to enter the help system.

- In the help system, you can get its help information by clicking on or tapping the link for the specified chapter.

### Parameter Setting Method

- For this instrument, you can use the knob and touch screen to set parameters. The common parameter setting methods are as follows.
- **Method 1:** Some parameters can be adjusted by rotating the knob on the front panel.
- **Method 2:** Click or tap the input field of a specified parameter, and then a virtual keypad is displayed. Complete the parameter setting with the keypad.

### Input a Value

- When setting or modifying a parameter, input an appropriate value with the numeric keypad.
- Click or tap the value or unit in the numeric keypad to complete the input.
- Rotate the multipurpose knob (1/2) to move the cursor to select the desired value and unit. Press the knob to confirm the input.



**Figure 8.1 Numeric Keypad**

- After you input all the values and select the desired units, the numeric keypad is turned off automatically. This indicates that you have completed the parameter setting.
- Besides, after you have input the values, you can also click or tap “OK” directly to close the numeric keypad. At this time, the unit of the parameter is the default unit.
- In the numeric keypad, you can perform the following operations.
- Set the parameter value to a maximum or minimum value;
- Set the parameter to a default value;
- Clear the parameter input field.

## Remote Control

The following ways of remote control are supported.

### User-defined Programming

- Users can program and control the instrument by using the SCPI (Standard Commands for Programmable Instruments) commands. For details about the SCPI commands and programming, refer to the Programming Guide of this product series.

### PC Software

- Users can use the PC software to send commands to control the instrument remotely. RIGOL Ultra Sigma is recommended. You can download the software from RIGOL's official website (<http://www.rigol.com>).

### Operation Procedures:

- Set up communication between the instrument and PC.
- Run Ultra Sigma and search for the instrument resource.
- Open the remote command control panel to send commands.
- Web Control
- This instrument supports Web Control. Connect the instrument to the network, then input the IP address of the instrument into the address bar of the browser of your computer. The web control interface is displayed. Click Web Control to enter the web control page. Then you can view the display of the real-time interface of the instrument. Through the Web Control method, you can migrate the device control to the control terminals (e.g. PC, Mobile, iPad, and other smart terminals) to realize remote control of the instrument. When you first log in to Web Control, the user name is “admin” and the password is “rigor”.
- This instrument can be connected to the PC via the USB and LAN interface to set up communication and realize remote control through the PC.
- The remote control can be realized by using SCPI (Standard Commands for Programmable Instruments) commands.
- **CAUTION** Before connecting the communication cable, please turn off the instrument to avoid causing damage to the communication interfaces.

### More Product Information

- Click or tap > Utility > About to obtain the information of the instrument, such as the model, serial number, and hardware version number.
- For more information about the instrument, refer to the relevant manuals by logging in to the official website of RIGOL (<http://www.rigol.com>) to download them.
- DHO900 User Guide introduces the functions of the instrument and the operation methods, remote control methods, possible failures, and solutions in using the instrument, specifications, and order information.
- DHO900 Programming Guide provides detailed descriptions of SCPI commands and programming examples of the instrument.
- DHO900 Data Sheet provides the key features and technical specifications of the instrument.

## HEADQUARTER

- RIGOL TECHNOLOGIES CO., LTD.
- No.8 Keling Road, New District, Suzhou,
- Jiangsu, P.R. China
- Tel: +86-400620002
- Email: info@rigol.com

## EUROPE

- RIGOL TECHNOLOGIES EU GmbH
- Carl-Benz-Str. 11
- 82205 Gilching
- Germany
- Tel: +49(0)8105-27292-0
- Email: info-europe@rigol.com

## NORTH AMERICA

- RIGOL TECHNOLOGIES, USA INC.
- 10220 SW Nimbus Ave.
- Suite K-7
- Portland, OR 97223
- Tel: +1-877-4-RIGOL-1
- Fax: +1-877-4-RIGOL-1
- Email: info@rigol.com

## JAPAN

- RIGOLJAPAN CO., LTD.
- 5F,3-45-6,Minamiotsuka,
- Toshima-Ku,
- Tokyo, 170-0005, Japan
- Tel: +81-3-6262-8932
- Fax: +81-3-6262-8933
- Email: info-japan@rigol.com
- RIGOL® is the trademark of RIGOL TECHNOLOGIES CO., LTD. Product information in this document is subject to update without notice.
- For the latest information about RIGOL's products, applications, and services, please contact local RIGOL channel partners or access RIGOL's official website: [www.rigol.com](http://www.rigol.com)

## Documents / Resources



### DHO900 Digital Oscilloscope

User Guide · DHO900, DHO900 Digital Oscilloscope, DHO900, Digital Oscilloscope, Oscilloscope

Published: August 19, 2024

## Related Topics

Oscilloscope

Digital Oscilloscope