

OLYMPUS

SZX-ILLK
SZX-ILLB2
SZX-ILLD2
SZX-AN
SZX-PO
SZH-CLJ
SZX-CL
SZX-TLGAD
LG-SF

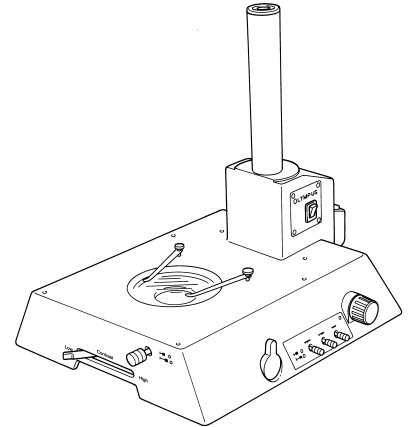

INSTRUCTIONS

SZX ILLUMINATION BASES

RESEARCH STEREOMICROSCOPE SYSTEM

This instruction manual is for the Olympus SZX Illumination Base. To ensure the safety, obtain optimum performance, and to familiarize yourself fully with the use of this product, we recommend that you study this manual thoroughly before operating the equipment. Retain this instruction manual in an easily accessible place near the work desk for future reference.

— This publication is printed on 100% recycled paper —



A X 6 4 9 6

IMPORTANT

This manual describes operation of SZX Illumination Base models only. For full details on operation and handling, you must also read the instruction manuals provided with the SZX Microscope Body and any other equipment that you will be using.

The information in this manual pertains to all three models in the SZX Illumination Base series. Differences between the models are summarized in the table below.

Item	Illumination base SZX-ILLK	Transmitted Light Illumination Base SZX-ILLB2	Advanced Transmitted Light Illumination Base SZX-ILLB2	Transmitted Brightfield/ Darkfield Illumination Base SZX-ILLD2
Maximum illuminated area	$\phi 40$ mm (1X or more objective)			$\phi 63$ mm: Brightfield observation $\phi 33$ mm*: Darkfield observation
Brightfield illumination	○		◎	
Darkfield illumination		-		○
Focal illumination		○		-
Built-in filter	-		LBD, ND6 & ND25, one for each	FR, LBD & ND25, one for each
Light bulb	6 V, 30 W halogen bulb.**			

* Achieved when using the 1X objective and 0.7X or higher zoom magnification.

** Optional light guide illumination unit.

◎: Suitable

○: Possible

- : Impossible

SAFETY PRECAUTIONS

- After the equipment has been used in an observation of a specimen that is accompanied with a potential of infection, clean the parts coming in contact with the specimen to prevent infection.
 - Moving this product is accompanied with the risk of dropping the specimen. Be sure to remove the specimen before moving this product.
 - In case the specimen is damaged by erroneous operation, promptly take the infection prevention measures.
 - The product becomes unstable if its height is increased by an accessory mounted on it. In this case, take anti-toppling measures to prevent the specimen from being dropped when the product topples down.
- Because the illumination base's built-in light bulb generates heat, it is important that you leave a clear space of at least 10 cm behind the lamp socket on the rear panel. Also be sure that the vents are not blocked.
- Install the illumination base on a firm, flat surface so that the vent on the bottom will not be blocked. Do not place the illumination base on a soft surface as the base will settle into the surface and the bottom vent will be blocked, causing a potential fire hazard.

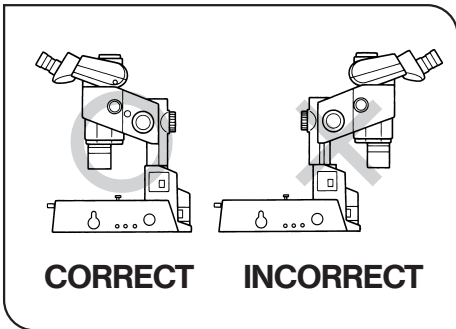

Fig. 1

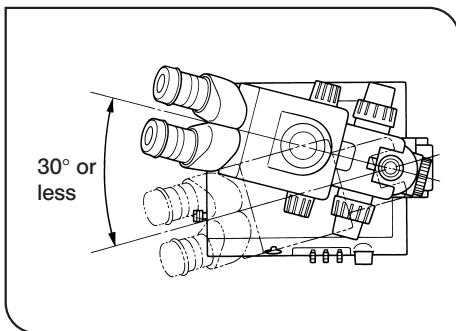

Fig. 2

4. When installing the microscope body, install it in the manner indicated by the “○” shown in the illustration on the left. The microscope will tip if it is installed the other way. Also be sure to keep the horizontal swivel angle at 30° or less. (Figs. 1 & 2)
5. Be sure to use the provided power cord. Safety and performance cannot be guaranteed otherwise.
6. Set the input voltage selector on the rear panel of the illumination base to the required voltage. (P. 4)
(The selector is factory preset at 110-120V or 230-240V)
7. Be sure to **ground** the unit. The designated electrical safety standard cannot be guaranteed otherwise.
8. Never put a metal object into the vent. This could cause a potential electric shock hazard or equipment failure.
9. To avoid potential shock hazards and burns when replacing the light bulb, make sure the main switch is set to “○” (OFF), the power cord is unplugged from the outlet, and that the bulb and the vicinity of the lamp socket have cooled sufficiently.

Applicable bulb	6 V 30 W HAL (PHILIPS 5761)
-----------------	-----------------------------

▲ Using a non-specified bulb could cause a potential fire hazard.

10. If water is spilled on the top panel of the illumination base, take prompt measures as instructed in “**2 Maintenance and Storage**” on next page.

Safety Symbols

The following symbols are found on the microscope. Study the meaning of the symbols, and always use the equipment in the safest possible manner.

Symbol	Explanation
	Indicates that the surface becomes hot, and should not be touched with bare hands.
	Before use, carefully read the instruction manual. Improper use could result in personal injury and/or damage to the equipment.
	Indicates that the main switch is ON.
	Indicates that the main switch is OFF.

Warning Engravings/Stickers

Warning engravings/stickers are placed at parts where special precaution is required when handling and using the unit. Always heed the warning.

Warning engraving position	Lamp socket [Warning against high temperature]	
Warning sticker position	Illumination base rear panel [Warning against high temperature]	

Should warning stickers become spoiled, peel off, etc., contact Olympus for replacement.

1 Getting Ready

1. An illumination base is a precision instrument. Handle it with care and avoid subjecting it to sudden or severe impacts.
2. Do not expose the unit to direct sunlight, high temperature and humidity, dust or vibrations. (For operating conditions, refer to "5. Specifications" on page 12.)
3. When the SZH-P400/P600 auxiliary pillar is mounted (when using the objective with long working distance), or when observing a thick specimen, make sure the microscope body is completely stable so that there is no chance that it will tip. (Be sure to use the SZX-R drop prevention collar.)

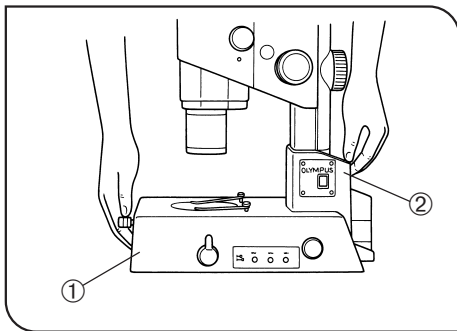

Fig. 3

4. To move the microscope body, lift it at the finger holds ① and ② on the illumination base. Do not hold the microscope body anywhere else. (Fig. 3)

Weight: Approx. 10.5 kg (23.1 lb) [Approx. 6 kg (13.2 lb) for Illumination base + Approx. 4.5 kg (9.9 lb) for SZX microscope]

2 Maintenance and Storage

1. Clean all glass components by wiping gently with gauze. To remove fingerprints or oil smudges, wipe with gauze slightly moistened with a mixture of ether (70%) and alcohol (30%).
 - ▲ Since solvents such as ether and alcohol are highly flammable, they must be handled carefully. Be sure to keep these chemicals away from open flames or potential sources of electrical sparks — for example, electrical equipment that is being switched on or off. Also remember to always use these chemicals only in a well-ventilated room.
2. Do not use organic solvents to clean non-optical components. If smudges are difficult to clean, wipe them with a soft cloth slightly moistened with a diluted neutral detergent.
3. The stage surface features a simplified waterproof design. However, precautions are still necessary if water is spilled on the surface. Set the main switch to "○" (OFF), unplug the power cord, and then wipe dry with a dry cloth immediately. Also remove the stage glass and wipe clean the window glass and surrounding area with soft gauze.
 - ▲ If water gets inside the unit, contact your Olympus representative to check electrical safety.
4. Pay attention to smudges on the waterproof glass and stage glass (especially when mounting and removing the filter). When these get dirty, the darkfield effect will be impaired; be sure to clean them thoroughly.
5. Never disassemble any part of the unit as this could cause malfunctions or reduced performance.
6. When the unit is not in use, make sure the main switch is set to "○" (OFF). When the lamp socket is cool, cover the unit with the dust cover provided with the microscope body.

3 Caution

If the equipment is used in a manner not specified by this manual, the safety of the user may be imperiled. In addition, the equipment may also be damaged. Always use the equipment as outlined in this instruction manual.

The following symbols are used to set off text in this instruction manual.

- ▲ : Indicates that failure to follow the instructions in the warning could result in bodily harm to the user and/or damage to equipment (including objects in the vicinity of the equipment).
- ★ : Indicates that failure to follow the instructions could result in damage to equipment.
- ◎ : Indicates commentary (for ease of operation and maintenance).

This device complies with the requirements of directive 98/79/EC concerning in vitro diagnostic medical devices. CE marking means the conformity to the directive.

NOTE: This equipment has been tested and found to comply with the limits for a Class A digital device, pursuant to Part 15 of the FCC Rules. These limits are designed to provide reasonable protection against harmful interference when the equipment is operated in a commercial environment. This equipment generates, uses, and can radiate radio frequency energy and, if not installed and used in accordance with the instruction manual, may cause harmful interference to radio communications. Operation of this equipment in a residential area is likely to cause harmful interference in which case the user will be required to correct the interference at his own expense.

FCC WARNING: Changes or modifications not expressly approved by the party responsible for compliance could void the user's authority to operate the equipment.

CONTENTS

1	NOMENCLATURE	1
2	ASSEMBLY	2
	2-1 Assembly Diagram	2
	2-2 Assembly Procedure	3
3	CONTROLS	6
4	OPERATION	7
	1 Adjusting the Optical Axis	7
	2 Compatible Objectives and Using the Frosted Filter	8
	3 Using the Built-in Filter ILLB2 ILLD2	9
	4 Using the Add-on Filter	9
	5 Using the Oblique Illumination Control ILLK ILLB2	10
	6 Using the Slit Aperture Illumination Control ILLB2	10
	7 Using the Contrast Selector ILLB2	11
	8 Using the Brightfield/Darkfield Illumination Selector ILLD2	11
	9 Taking Photographs (Color Temperature Adjustment)	11
5	SPECIFICATIONS	12
6	TROUBLESHOOTING GUIDE	13
7	USING OPTIONAL ACCESSORIES	15
	7-1 SZX-AN Analyzer and SZX-PO Simplified Transmitted Light Polarizer	15
	7-2 SZH-CLJ Spring-Clip Specimen Holder	17
	7-3 SZX-CL Large Transparent Stage Plate	18
	7-4 SZX-TLGAD Transmitted Light Guide Adapter/ LG-SF Flexible Light Guide	19
	■ PROPER SELECTION OF THE POWER SUPPLY CORD	20

1 NOMENCLATURE

This illustration shows the SZX-ILLB2.

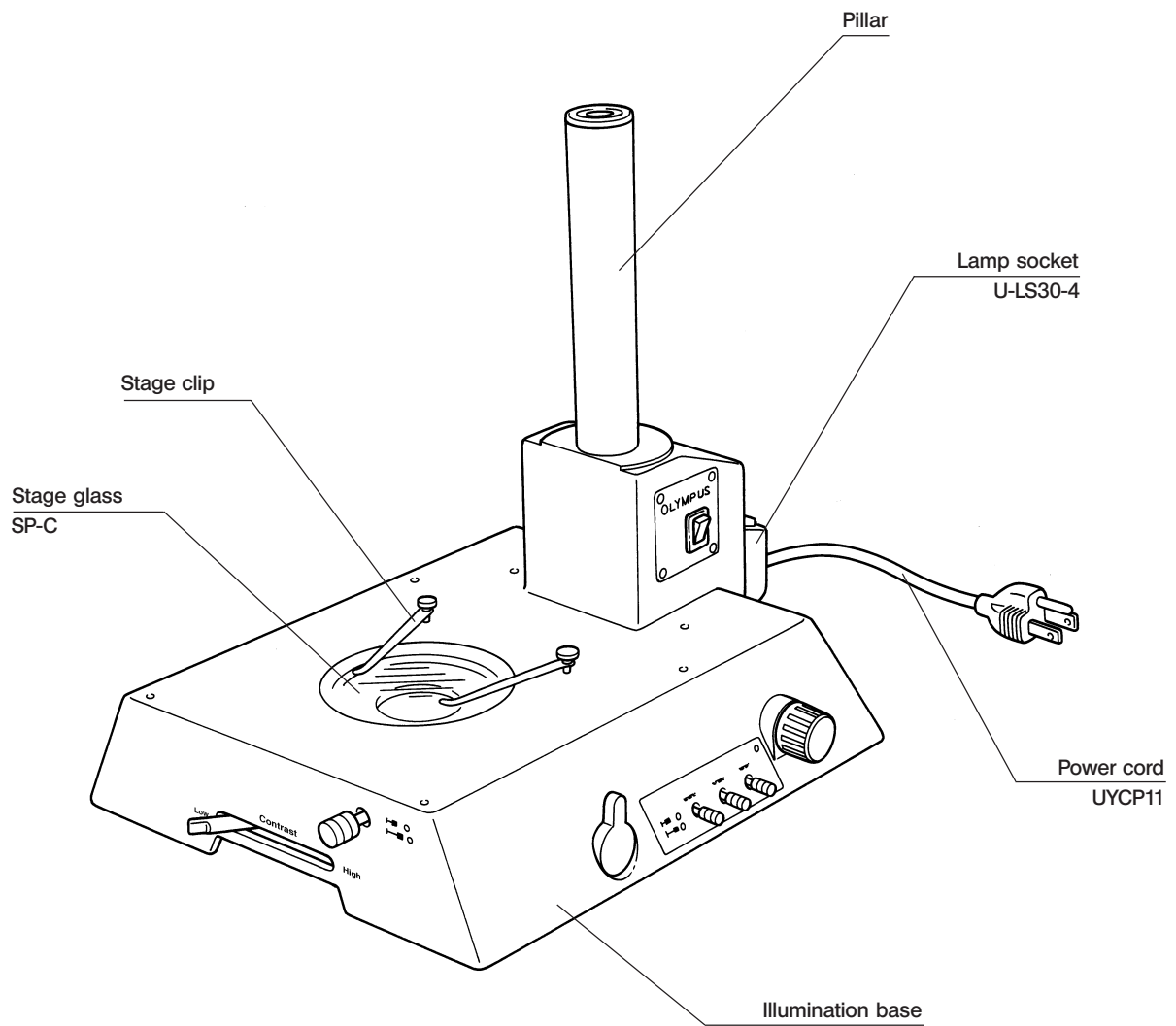

2 ASSEMBLY

2-1 Assembly Diagram

The diagram below shows the sequence of assembly of the various modules. The numbers indicate the order of assembly.
★ When assembling the equipment, make sure that all parts are free of dust and dirt, and avoid scratching any parts or glass surfaces.

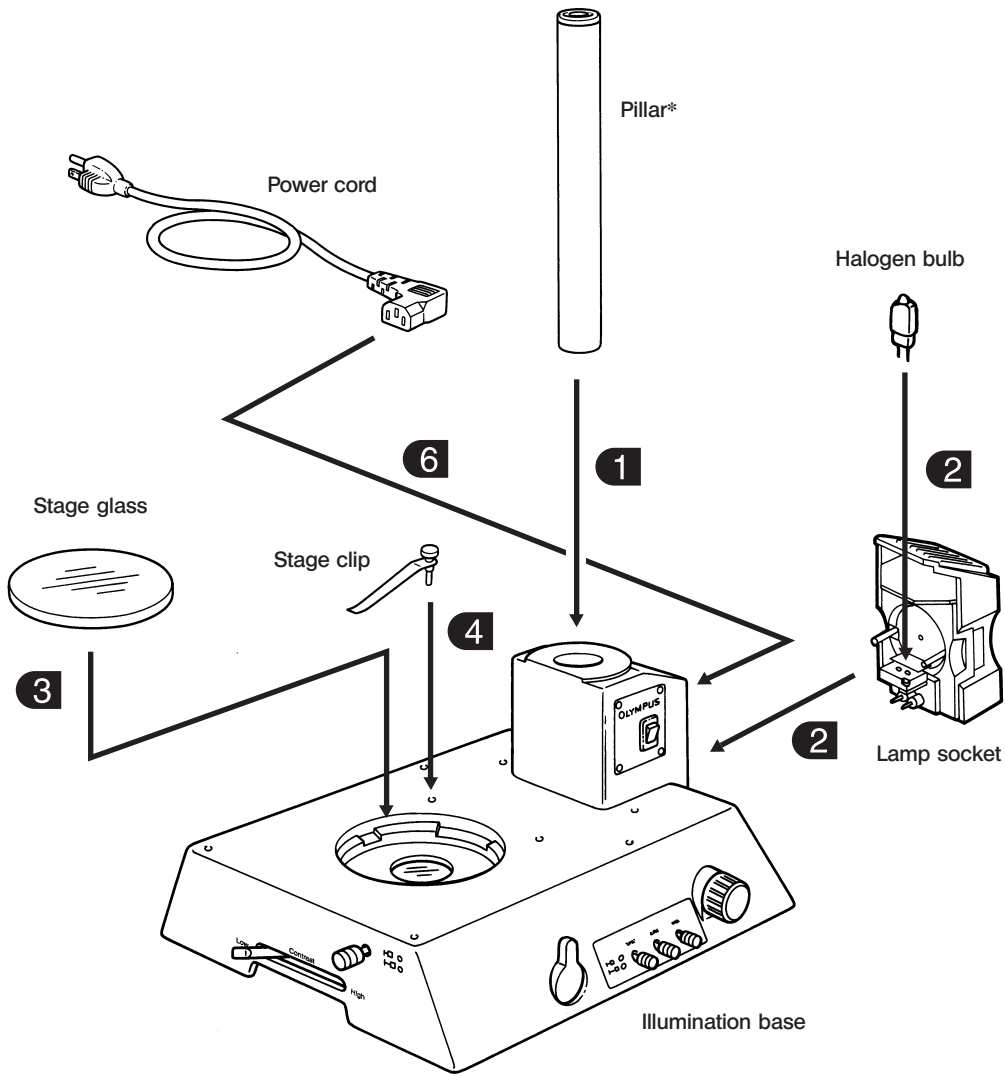

Required tool

Allen wrench	
(Provided with the illumination base)	

* The tip of the pillar incorporates a storage hole to accommodate the Allen screwdriver which is provided with the zoom microscope body.

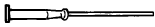

2-2 Assembly Procedure

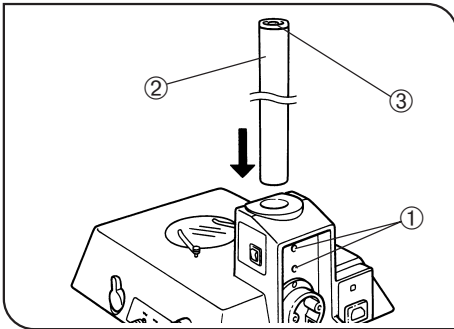

Fig. 4

1 Mounting the Pillar (Fig. 4)

1. Loosen the two pillar clamping screws ① on the rear panel of the illumination base with the provided Allen wrench.
2. With the Allen screwdriver storage hole ③ facing upward, insert the pillar ② gently into the mounting hole and push it in as far as it will go.
3. Tighten the pillar clamping screws ① securely.

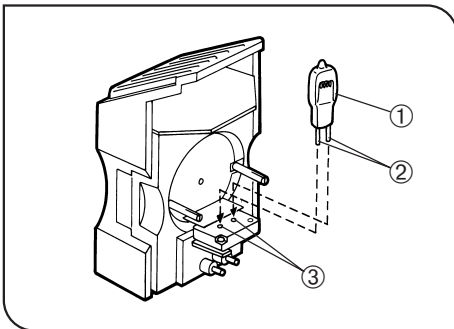

Fig. 5

2 Installing the Lamp Socket (Figs. 5 & 6)

Use only the specified Philips 5761 halogen bulb, 6 V, 30 W HAL.

1. Hold the bulb ① with gauze or other protective material and insert the bulb pins ② straight into the lamp socket's pin holes ③ as far as they will go. (Fig. 5)

★ **To prevent reduced bulb life or cracking, do not touch the bulb with bare hands. If fingerprints are accidentally left on the bulb, wipe the bulb with a soft cloth.**

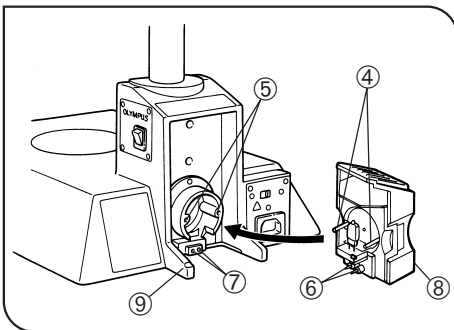
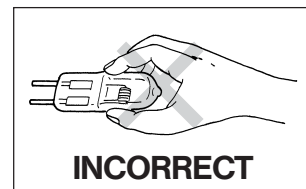

Fig. 6



2. Align the guide pins ④ with the guide holes ⑤ on the rear panel of the illumination base. Insert the plug ⑥ into the socket ⑦. Then press the lamp socket against the illumination base to make sure the lamp socket's rear panel ⑧ is lined up with the contour ⑨ of the illumination base (Fig. 6).

▲ **Bulb replacement during use or after use:**

The bulb and the lamp socket surfaces and vicinity will be extremely hot during use and right after use. Set the main switch to "O" (OFF) and disconnect the power cord from the wall outlet. Then allow the old bulb, lamp socket and vicinity to cool before replacing the bulb.

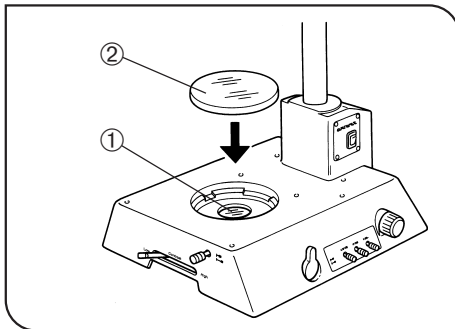

Fig. 7

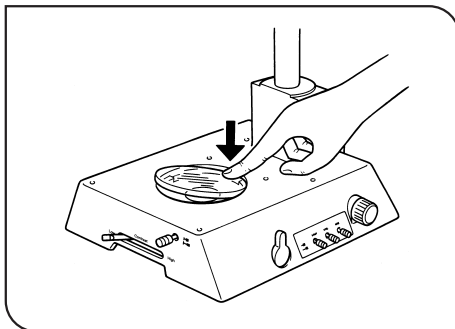

Fig. 8

3 Mounting and Removing the Stage Glass (Figs. 7 & 8)

★ Make sure there is no dust or smudge on the window lens and waterproof glass. Clean the glass ① if necessary (Fig. 7).

1. Clean the stage glass ② first and gently place it on the mounting hole on the top panel of the illumination base. (Fig. 7)

★ Dust and smudges are especially noticeable in darkfield and low-magnification observation.

⊙ To remove the stage glass, push the edge of the stage glass nearest the pillar with your fingertip. When the edge on the other side rises, grasp that edge to remove the stage glass. (Fig. 8)

4 Mounting the Stage Clips

⊙ To fix a specimen on the stage for observation, use stage clips.

1. Insert the stage clips into the two mounting holes on the top panel of the illumination base.

⊙ If the stage clip shaft ① is loose in the mounting hole, open the slit slightly at the end of the shaft using a flat-blade screwdriver ②.

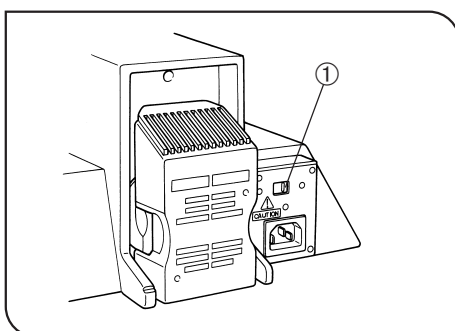
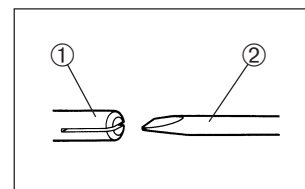

Fig. 9

5 Setting the Input Voltage

(Fig. 9)

⊙ Input voltage is factory-set to 110 – 120 V or 230 – 240 V to assure safety.

1. Set the input voltage selector ① on the rear panel of the illumination base to the required voltage using a flat-blade screwdriver.

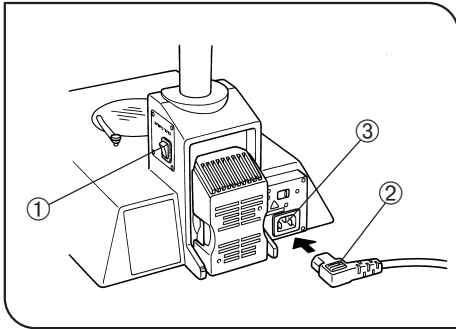

Fig. 10

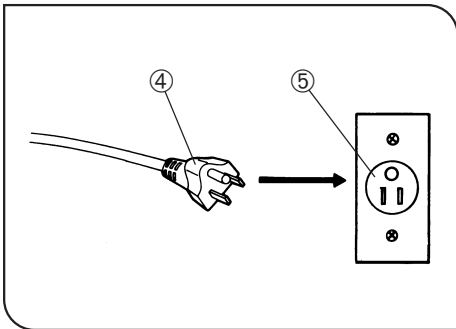

Fig. 11

6 Connecting the Power Cord (Figs. 10 & 11)

- ▲ Do not subject the power cord to excessive force. Cables and cords are more susceptible to damage when bent or twisted.
- ▲ Make sure the main switch ① is set to “O” (OFF) before connecting the power cord. (Fig. 10)
- ▲ Always use the power cord provided by Olympus. If no power cord is provided, please select the proper power cord by referring to the section “PROPER SELECTION OF THE POWER SUPPLY CORD” at the end of this instruction manual.

1. Insert the power cord plug ② into the connector ③ securely (Fig. 10).

- ▲ Connect the power cord to a 3-conductor power outlet that is grounded. If the grounding terminal of the power outlet is not grounded properly, Olympus can no longer warrant the electrical safety performance of the equipment. (Fig. 11)

2. Insert the power cord plug ④ into the wall outlet ⑤ securely (Fig. 11).

- ▲ Distribute the power cord apart from the lamp socket, as the cord may melt and cause electric shock if it contacts the lamp socket or its surroundings.

Connect the power cord correctly and ensure that the ground terminal of the power supply and that of the wall outlet are properly connected. If the equipment is not grounded, Olympus can no longer warrant the electrical safety and performance of the equipment.

3 CONTROLS

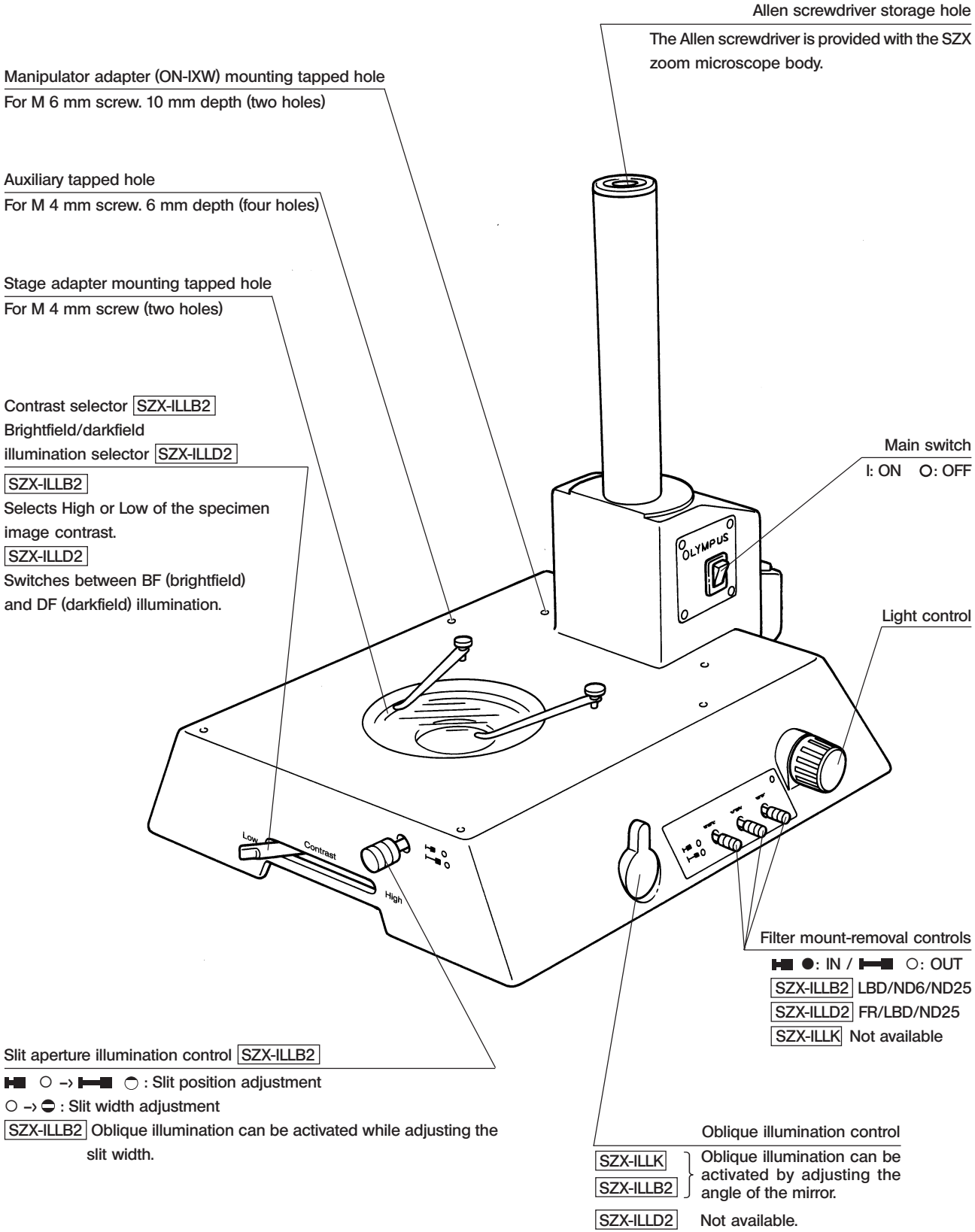

4 OPERATION

©When a model(s) is specified in the title, the procedures that follow apply only to that model(s). When no model is specified in the title, the procedures that follow apply to all models.

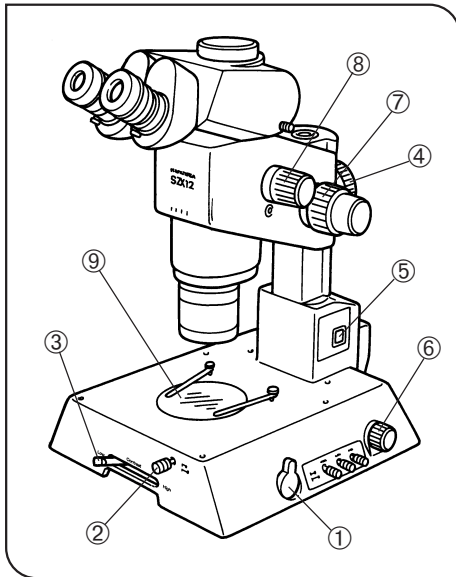

Fig. 12

1 Adjusting the Optical Axis

(Fig. 12)

★ This procedure is vital to eliminating uneven illumination and shaded edges. Always be sure to perform it.

1. Set the microscope mode to transmitted brightfield observation.

Control	Transmitted brightfield observation status.
• Oblique illumination control ①	Vertical position.
• Slit aperture illumination control ②	○ Wide-open. ■ ○ Pushed-in.
• Contrast selector ③	Set to the " High " or " Low " end position.
• Brightfield/darkfield illumination selector ③	Set to " BF ".

2. When using the SZX-ILLD2, only the filter adapter should be set on the waterproof glass as instructed on page 9.

3. While holding the zoom microscope body, loosen the locking knob ④ on the focusing section and slowly lower the microscope body until it stops.

4. Set the main switch ⑤ to " I " (ON).

5. Turn the light control ⑥ counterclockwise to set the light intensity at minimum.

6. Turn the coarse-adjustment knob ⑦ until the microscope body is raised to the upper limit.

7. Turn the zoom knob ⑧ to decrease the magnification to the minimum position. Then look through the eyepieces so that you can see the window lens frame ⑨ on the illumination base.

8. If the frame appears as shown in ① or ② in the diagrams below, move the microscope body to the left or right until the frame appears as shown in ③. When the frame is properly positioned, tighten the locking knob ④ on the focusing section.

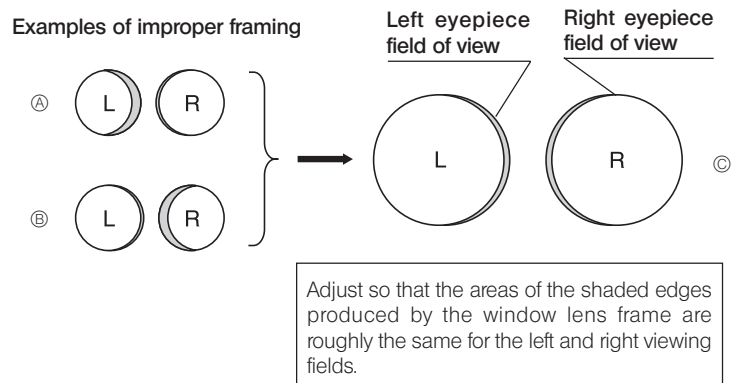

2 Compatible Objectives and Using the Frosted Filter

◎ The following table shows the standard way to use the 45OPL frosted filter provided with the SZX-ILLK [ILLK]. The 45OPL increases the evenness of illumination but decreases brightness. Mount or remove it according to your preferences and requirements.

illumination base	Objective	45OPL necessity	Limitation
Transmitted Light Illumination Base SZX-ILLK	0.5 – 0.75X	x	Edges are shaded at lower magnification.
	1 – 1.2X	x	
	1.5X –	○	
Advanced Transmitted Light Illumination Base SZX-ILLB2	0.5 – 0.75X		Edges are shaded at lower magnification.
	1X –		
Transmitted Brightfield/Darkfield Illumination Base SZX-ILLD2 (brightfield illumination)	0.5X		<ul style="list-style-type: none"> • Use the built-in FR frosted filter at lower magnification. However, illumination remains slightly uneven. • Edges are shaded at lower magnification when the SZX-CL is used.
	0.75 – 1.2X		
	1.5X –		Use the built-in FR frosted filter at lower magnification.
Transmitted Brightfield/Darkfield Illumination Base SZX-ILLD2 (darkfield illumination*)	0.5 – 0.75X		<ul style="list-style-type: none"> • Edges are slightly shaded at lower magnification. • Edges are completely shaded at lower magnification when the SZX-CL is used.
	1X		Edges are shaded at lower magnification when the SZX9 is used.
	1.2X –		

○ : Mounted
x : Not mounted

* The SZX-STAD1 and SZH-STAD1 cannot be used for darkfield illumination.

Unusable when the SZX-CL large transparent stage plate is used by setting the glass plate clearance to 22 mm.

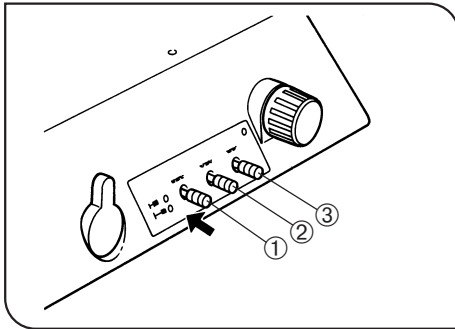

Fig. 13

3 Using the Built-in Filter **ILLB2** **ILLD2** (Fig. 13)

◎The SZX-ILLB2 and SZX-ILLD2 each incorporate three filters.

1. Push in one of the filter mount-removal controls ① – ③ to bring the required filter into the light path.

Filter Types

	SZX-ILLB2	SZX-ILLD2
①	LBD (color temperature conversion)	FR (frosted/diffused)
②	ND6 (light intensity adjustment with 6% transmittance)	LBD (color temperature conversion)
③	ND25 (light intensity adjustment with 25% transmittance)	ND25 (light intensity adjustment with 25% transmittance)

◎When the ND6 and ND25 overlap, transmittance is reduced to 1.5%.

◎The FR filter has a light intensity attenuation effect, allowing it to be used as a substitute for the ND filter.

4 Using the Add-on Filter (Fig. 14)

◎In addition to the built-in filters, the $\phi 45$ mm frosted filter (45OPL) provided with the SZX-ILLK or any $\phi 45$ mm filters can be mounted beneath the stage glass. (Maximum thickness: 5 mm)

◎Use the frosted filter when you want to observe a dyed tissue specimen with the illumination as flat as possible (oblique illumination does not function). Also use it to eliminate uneven illumination at low magnification.

1. Remove the stage glass ①.
2. Make sure the filter is free from dust or smudges. Clean it if necessary.
3. Mount the $\phi 45$ -mm filter.

ILLK **ILLB2**

Gently set the $\phi 45$ -mm filter ② onto the filter holder on the window lens ④.

ILLD2

Place the $\phi 45$ -mm filter ② in the filter adapter ③. Gently place them together on the filter holder on the waterproof glass ④.

★ **Using the filter with the filter holder limits the area illuminated.**

◎To remove, grasp the filter or adapter through the notches ⑤ on the window lens or waterproof glass ④ and take it out.

★ **Be careful not to get fingerprints on the filter.**

4. Replace the stage glass ①.

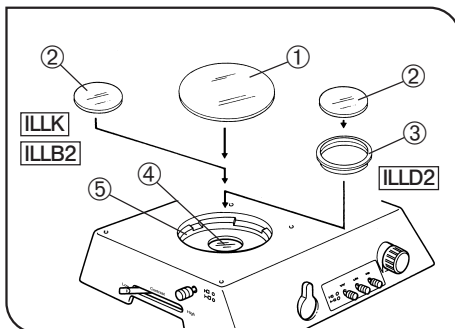

Fig. 14

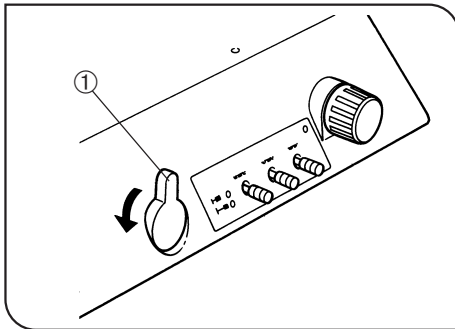

Fig. 15

5 Using the Oblique Illumination Control [ILLK] [ILLB2]

(Fig. 15)

⊙The SZX-ILLK and SZX-ILLB2 are provided with an oblique illumination function. This enables contours of transparent objects in liquid to be observed with enhanced contrast. (The 45OPL frosted filter cannot be used.)

1. While looking through the eyepieces, gradually turn the oblique illumination control ① until proper contrast is achieved.
2. Results depend on the objective magnification as shown in the table below.

Objective magnification	SZX-ILLK	SZX-ILLB2
0.5X – 0.75X	Shaded at low magnification	
1 – 1.2X	Good	
1.5X –	Illumination unevenness	Good

- The oblique illumination effect decreases when the SZX-STAD1, SZH-STAD1 or SZX-CL is used.

★When a filter (IF550, etc.) is mounted beneath the stage glass, ghosting may occur when using oblique illumination at low magnification.

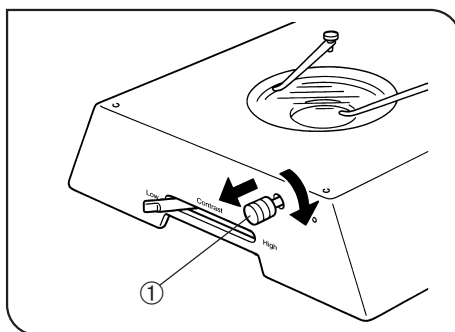

Fig. 16

6 Using the Slit Aperture Illumination Control [ILLB2]

(Fig. 16)

⊙The SZX-ILLB2 is provided with a slit aperture illumination function. At high zoom magnifications with a 1.5X or more objective, appropriate contrast is added to transmitted transparent objects to achieve three-dimensional observation.

1. Turn the slit aperture illumination control ① and pull it out gradually to determine the position where ideal contrast is achieved in relation to the specimen and magnification.
 2. When not using the slit aperture, push in the slit aperture illumination control ① and turn it clockwise as far as it will go.
- Turning the control opens and closes the slit aperture to improve contrast when observing a specimen.
 - Pulling and pushing the control achieves oblique illumination through the slit aperture, enabling transparent objects to cast shadows.
 - The slit aperture is designed for high-magnification observation. At low magnification, the edges of the viewing field may be shaded. Should this happen, use the oblique illumination function as instructed in “ **5 Using the Oblique Illumination Control** ”.

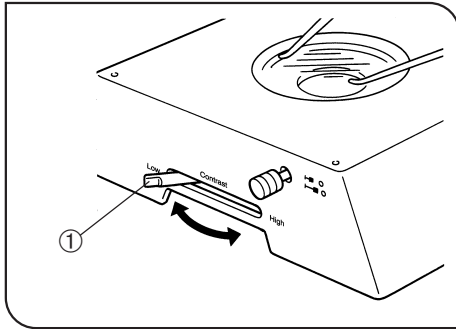

Fig. 17

7 Using the Contrast Selector [ILLB2] (Fig. 17)

- ⊙ In general, the “ High ” position gives illumination with higher contrast than the “ Low ” position.
- As the visibility varies depending on the specimen condition, it is recommended to try both positions and select the one offering the better visibility.

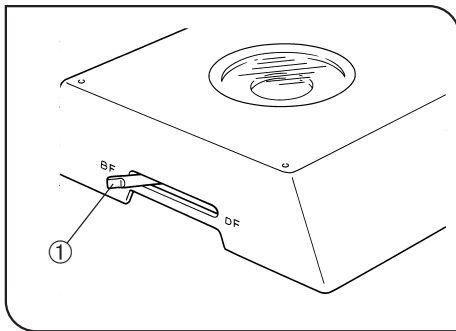

Fig. 18

8 Using the Brightfield/Darkfield Illumination Selector [ILLD2] (Fig. 18)

- ⊙ The SZX-ILLD2 is provided with a brightfield/darkfield illumination selector. Use this selector to switch between brightfield and darkfield observation.

BF: Transmitted Brightfield Observation

- Set the selector ① to the “ BF ” side as far as it will go.
- ★ When using a 0.5X or 0.75X objective with the zoom set at a lower magnification, uneven illumination may occur. In this case, put the built-in FR (frosted) filter into the light path to reduce uneven illumination.

DF: Transmitted Darkfield Observation

- Set the selector ① to the “ DF ” side as far as it will go. Pull the built-in FR filter to the “ OUT ” position. To achieve brighter images, pull all the filter mount-removal controls to the “ OUT ” positions.
- ★ When activating darkfield illumination, smudges on the stage glass, waterproof glass, and filter may obstruct observation. In this case, clean each component as instructed in “ 4 Operation ”, “ 4 Using the Add-on Filter ” on page 9 . The illuminated area will be restricted when the filter is mounted on the filter adapter and placed beneath the stage glass.

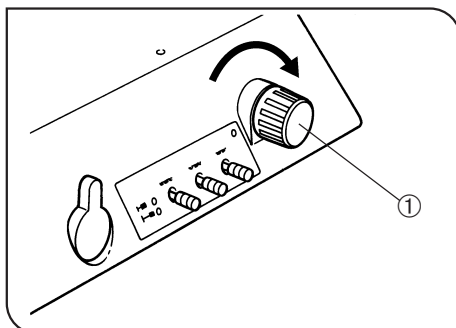

Fig. 19

9 Taking Photographs (Color Temperature Adjustment) (Fig. 19)

- ⊙ In color photography, it is important to engage the LBD or 45KB4 filter in the light path for color temperature adjustment and set the light control knob to an optimum position. If precise color temperature adjustment is required, use a color thermometer.

1. Engage the color temperature adjustment filter in the light path.
 - [ILLB2] [ILLD2]: Engage the LBD filter, built into the base, into the light path.
 - [ILLK]: Place the built-in 45KB4 filter beneath the stage glass.
2. Set the light control knob ① to the maximum position.
 - If the finished picture is bluish at this setting, return the light control knob ① slightly from the maximum position.
3. After setting the light control knob, the brightness of the [ILLB2] and [ILLD2] can be adjusted using the built-in ND filter.

- ⊙ With the [ILLD2], the FR can also be used in the brightness adjustment.

- ⊙ In digital camera photography, the color temperature can also be adjusted using the color temperature adjustment function of the camera.

5 SPECIFICATIONS

Item	Specification		
	SZX-ILLK	SZX-ILLB2	SZX-ILLD2
Light source	Philips 5761 6V30W/30W halogen bulb, 6 V, 30 W (Average bulb service life: Approx. 100 hours under rated usage conditions)		
Light intensity adjustment	Continuously variable system (with built-in transformer)		
Effective illuminated area	$\phi 40$ mm		Brightfield: $\phi 63$ mm Darkfield: $\phi 33$ mm
Built-in filter	—	LBD, ND6, ND25, one for each	FR, LBD, ND25, one for each
Add-on filter	Variety of $\phi 45$ mm filters can be mounted. (In case filters are stacked, the maximum total thickness of the filters is 5 mm.) [ILLK]: $\phi 45$ mm frosted filter (45OPL) and $\phi 45$ mm color temperature adjustment filter (45KB4) provided.		
Illumination type	<ul style="list-style-type: none"> • Transmitted brightfield illumination (• Oblique illumination) 	<ul style="list-style-type: none"> • Transmitted brightfield illumination (• Oblique illumination) (• Slit aperture illumination) 	<ul style="list-style-type: none"> • Transmitted brightfield illumination • Transmitted darkfield illumination
Contrast selection	—	Selection between High/Low.	—
Pillar height	270 mm		
Weight	Approx. 6 kg (13.2 lb)	Approx. 6.2 kg (13.6 lb)	
Rated voltage	100V area : 100/110–120V \sim 0.6 A, 50/60 Hz 200V area : 220/230–240V \sim 0.3 A, 50/60 Hz		
Operating environment	<ul style="list-style-type: none"> • Indoor use • Altitude up to 2000 m • Temperature: 5°C to 40°C (41°F to 104°F) • Maximum relative humidity 80% for temperatures up to 31°C (88°F) decreasing linearly to 50% relative humidity at 40°C (104°F) • Main supply voltage fluctuations not to exceed $\pm 10\%$ of nominal voltage • Installation/Overvoltage Category: II (in accordance with IEC60664) • Pollution Degree: 2 (in accordance with IEC60664) 		

6 TROUBLESHOOTING GUIDE

Under certain conditions, performance of this unit may be adversely affected by factors other than defects. If problems occur, please review the following list and take remedial action as needed. If you cannot solve the problem after checking the entire list, please contact your local Olympus representative for assistance.

Problem	Cause	SZX-			Remedy	Page
		ILLK	ILLB2	ILLD2		
1. Optical System						
a) Illumination is too bright or too dark.	The light control is not set correctly.	○	○	○	Adjust the light intensity appropriately.	-
	ND filter selection is incorrect.	-	○	○	Set correctly.	9
	The built-in FR filter is in the light path in darkfield observation.	-	-	○	Take the FR out of the light path.	9
	The input voltage selector is set incorrectly.	○	○	○	Set according to the required voltage.	4
b) Illumination is noticeably uneven.	The bulb is not mounted correctly.	○	○	○	Mount correctly.	3
	The contrast selector and various controls are not set correctly.	○	○	○	Set correctly.	11
	The oblique illumination control has been turned too far.	○	○	-	Restore it to the original position.	10
	The slit aperture illumination control has been pulled out too far.	-	○	-	Push in appropriately.	10
	The filter mount-removal control is stopped halfway.	-	○	○	Push it in all the way.	9
	The window lens, waterproof glass and stage glass are dirty.	○	○	○	Wipe clean.	iii
	The built-in FR filter is not in the light path when using a 0.5X or 0.75X objective.	-	-	○	Put it in the light path.	9
	The optical axis of the main unit has deviated.	○	○	○	Adjust it correctly.	7
c) Dust and smudges are noticeable in the field of view.	The window lens, waterproof glass and stage glass are dirty.	○	○	○	Wipe them clean.	iii
	The eyepiece is dirty.	○	○	○	Wipe it clean.	iii

Problem	Cause	SZX-			Remedy	Page
		ILLK	ILLB2	ILLD2		
d) The image appears shiny. (The resolution deteriorates.)	The aperture iris diaphragm on the microscope body is stopped down.	○	○	○	Open the aperture iris diaphragm.	-
	The illumination quality is suited to the specimen.	○	○	○	Bring the 45OPL filter or FR filter into the light path to achieve flat illumination.	9
	The oblique illumination control is turned too far.	○	○	-	Restore it to the correct position to adjust contrast.	10
e) Poor color reproduction of color pictures.	The light control is not set to maximum.	○	○	○	Set the light control to the maximum position.	11
	The finished picture is reddish due to low color temperature setting.	-	○	○	The light control knob has been turned back excessively. Turn it toward the maximum position.	11
	The finished picture is bluish due to high color temperature setting.	-	○	○	Turn the light control knob back slightly.	11
	The built-in LBD or 45KB4 filter is not selected.	○	○	○	Select whichever one is required.	9
	The color is different from the observer's preference.	○	○	○	Compensate the color using a commercially available CC filter, etc.	-
2. Electrical System						
a) The bulb does not light.	The bulb is not mounted.	○	○	○	Mount the specified bulb.	3
	The bulb is burned out.	○	○	○	Replace it with a new one.	3
	The input voltage selector does not match the line voltage.	○	○	○	Select accordingly.	4
b) The bulb burns out frequently.	The line voltage is too high.	○	○	○	Reduce the line voltage using a transformer.	-
	A non-specified bulb is being used.	○	○	○	Replace it with the specified bulb.	3
c) The bulb turns on and off.	The bulb is about to burn out.	○	○	○	Replace it with a new one.	3
	The lamp socket and power cord connector are not connected securely.	○	○	○	Connect them securely.	3,5

○ : Possible cause

7 USING OPTIONAL ACCESSORIES

7-1 SZX-AN Analyzer and SZX-PO Simplified Transmitted Light Polarizer

©Combining the SZX-AN analyzer and SZX-PO polarizer using the transmitted light illumination base allows simplified transmitted light polarized light observation to be performed. The specimen's transmitted light polarizing characteristics (birefringence and polarization) can be detected easily.

★ Replace the stage plate with SP-C stage glass to facilitate transmitted light illumination observation.

1 Nomenclature

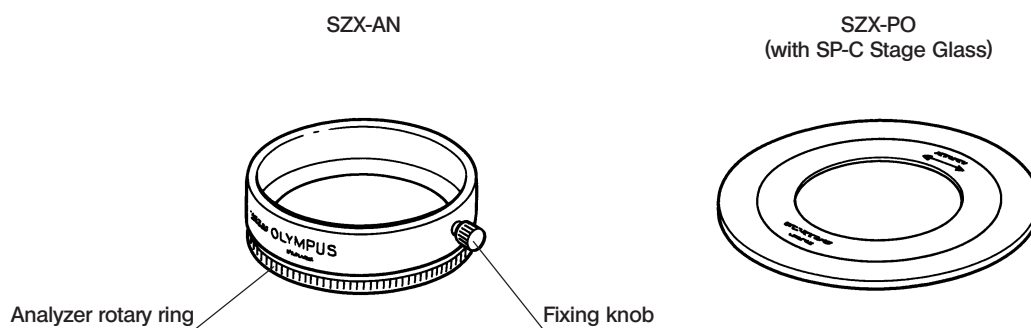

2 Handling Precautions

- Ambient temperature: 5°C to 40°C (41°F to 104°F): storage temperature – 50°C (122°F) or less
 - The SZX-AN and SZX-PO cannot be used with the 45OPL frosted filter that is provided with the SZX-ILLK transmitted light illumination base.
- ★ When the SZX-ILLK is used with a 1.6X/2X objective or AL20X supplementary objective, the edges of the viewing field will be shaded. With other objectives, polarization observation can be performed without any problem.

3 Assembly

(Figs. 20 & 21)

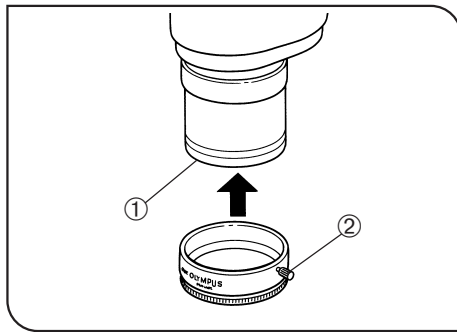

Fig. 20

1. Mounting the analyzer

- With the SZX-AN's label-side facing to the front, insert the analyzer into the distal end of the objective ① as far as it will go. Then tighten the fixing knob ② firmly. (Fig. 20)

★ Insert the analyzer carefully so that it is not mounted on a slant.

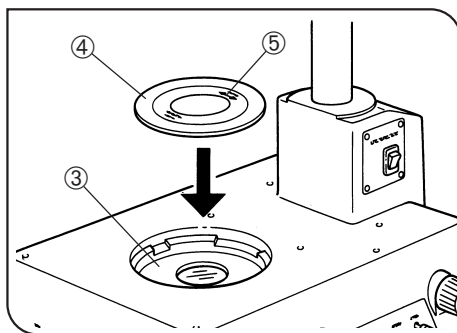

Fig. 21

2. Mounting the polarizer

- Push the edge of the stage glass near the pillar to remove the stage glass.
- Place the polarizer ④ in the polarizer mounting hole with the arrow ⑤ facing up. (Fig. 21)

★ Set the polarizer so that the arrow ⑤ points sideways (polarizer vibration direction). (Fig. 21)

- Replace the stage glass.

4 Operation

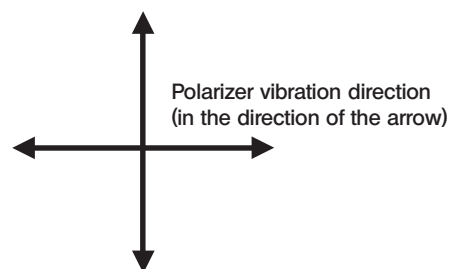

Analyzer vibration direction
(in the position of the white dot)

“Crossed filter” condition

To observe specimen birefringence

1. Make sure there is no specimen on the stage glass. Then turn the analyzer rotary ring until the field of view is pitch-black (“crossed filter” position).
 2. Place a specimen on the stage glass. Turn the specimen or stage glass to perform polarized light observation.
- ⊙ The birefringence of the specimen changes from dark to bright according to the rotation.
 - ⊙ Contrast can sometimes be enhanced by stopping down the aperture diaphragm.

To examine specimen polarization

1. Remove the polarizer.
 2. Turn the analyzer or specimen to perform polarized light observation.
- ⊙ When there is polarization, the specimen changes from dark to bright according to the rotation.

7-2 SZH-CLJ Spring-Clip Specimen Holder

© Especially recommended for use with the SZX-ILLD2, this accessory holds a gem or similar specimen for inspection using dark-field illumination.

How to Use the SZH-CLJ

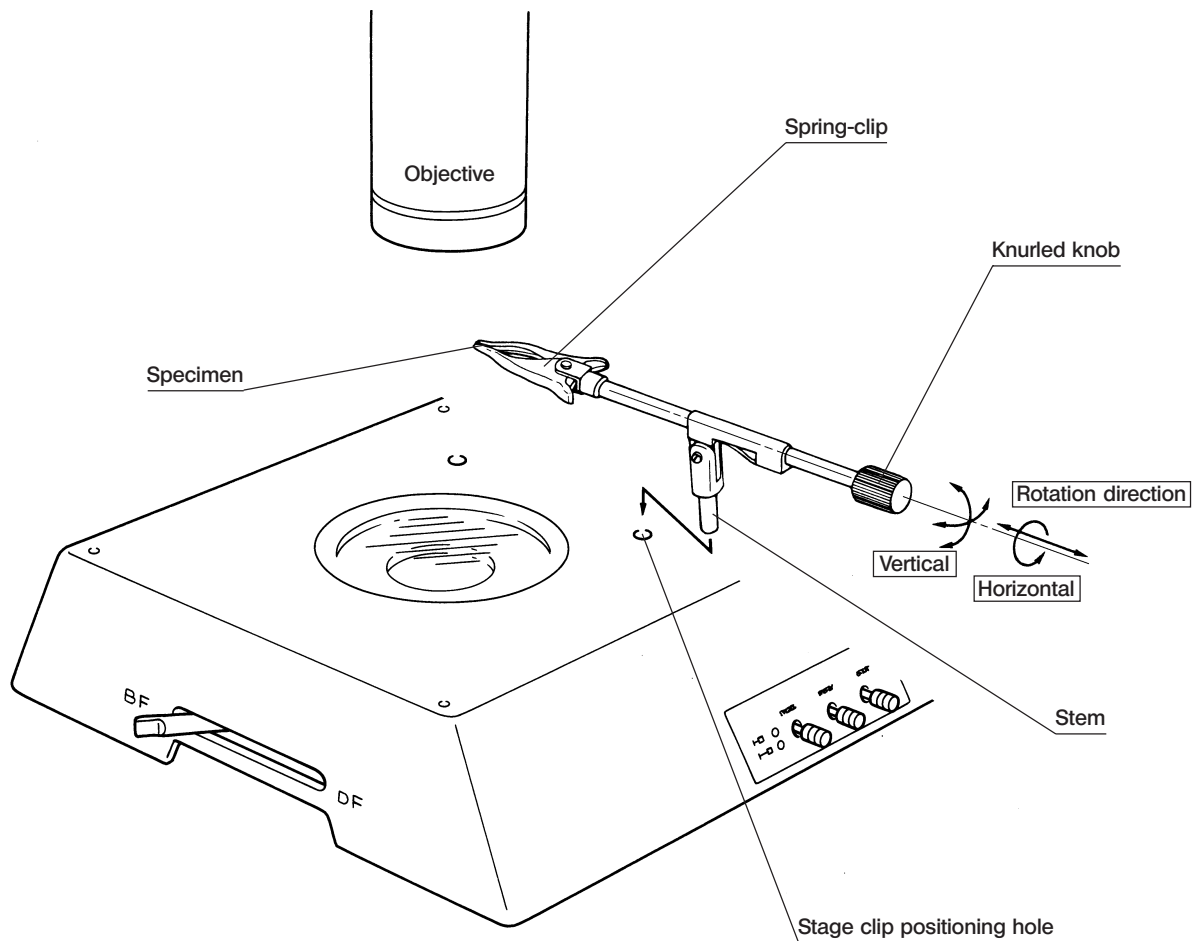

Hold the knurled knob and move the specimen forwards, backwards, up, down, and sideways until it moves into the light path.

7-3 SZX-CL Large Transparent Stage Plate

◎ This plate prevents contamination when a raw specimen is used, as well as insulating heat, and facilitating disinfection. Colored paper and cellophane can also be put beneath the transparent stage plate to achieve a background effect (illumination) in macro photography.

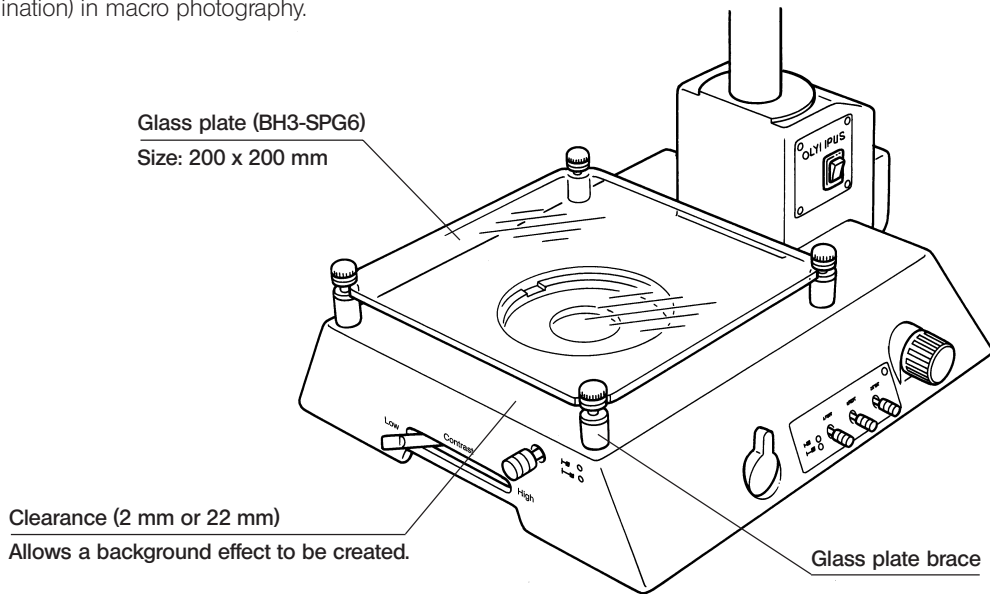

1 How to Assemble the SZX-CL

(Fig. 22)

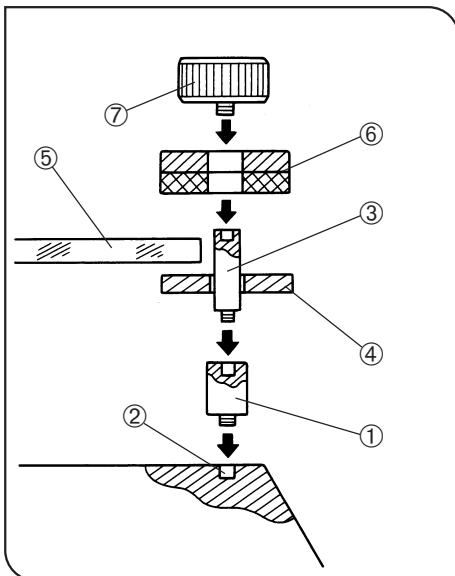

Fig. 22

Setting the clearance at 22 mm

1. Screw the brace ① into the tapped hole ② on the top panel of the illumination base with a coin or similar tool. (Repeat this procedure four times.)
2. Using a coin or similar tool, screw the brace shaft ③ into the brace ①. (Repeat this procedure four times.)
3. Put the polyacetal washer ④ over the brace shaft ③. (Repeat this procedure four times.)
4. Set the glass plate ⑤ so that each of the plate's chamfers is placed on the washer ④. Make sure all four corners sit on the washers securely.
5. With the rubber side down, put the resin washer ⑥ on the brace shaft ③.
6. Screw the clamping knobs ⑦ into the brace shaft ③ to fix the glass plate securely. (Repeat this procedure four times.)

★ If the clamping knob loosens, the glass plate may come off. Tighten the screws occasionally.

Setting the clearance at 2 mm

Without using the brace ①, screw the brace shaft ③ directly into the tapped hole ② on the top panel of the illumination base.

7-4 SZX-TLGAD Transmitted Light Guide Adapter/LG-SF Flexible Light Guide

Together, this adapter and light guide allow you to install a light source separately from the transmitted light illumination base. This prevents any increase in the base temperature and is especially useful when precise temperature control of specimens is critical.

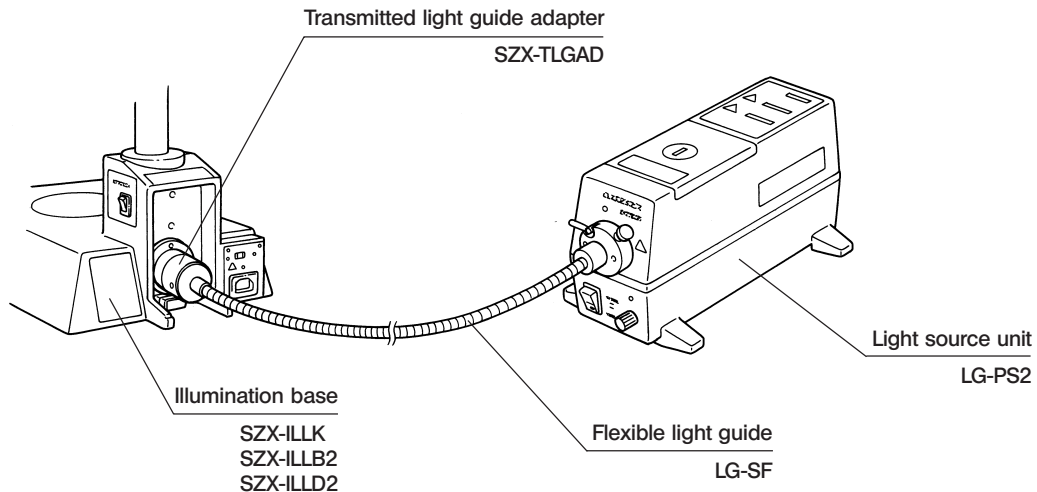

1 Assembly and Operation

(Figs. 23 & 24)

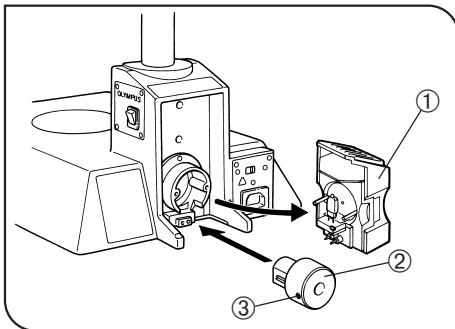

Fig. 23

1. Remove the lamp socket ① from the illumination base by gently pulling the socket straight out. (Fig. 23)
2. Hold the transmitted light guide adapter ② so that its clamping screw ③ faces sideways, align the guide pin with the guide hole just as with the lamp socket, and push in the adapter until it stops. (Fig. 23)

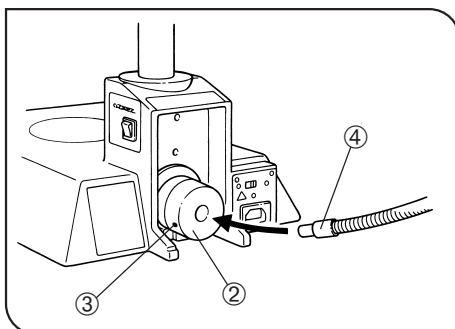

Fig. 24

3. Insert the output end ④ of the flexible light guide into the light guide adapter ② until it stops, and tighten the clamping screw ③ using the Allen screwdriver provided with the microscope body. (Fig. 24)
4. Attach the input end of the light guide to the LG-PS2 light source unit. Refer light guide illumination system instruction manual for details.
5. For instructions on operation, refer to the LG-PS2 light source unit instruction manual.

★ Some light may be lost during transmission through the light guide. As a result, the illumination provided when using this adapter and light guide may be less than that obtained with a configuration using the U-LS30-4 lamp socket.

■ PROPER SELECTION OF THE POWER SUPPLY CORD

If no power supply cord is provided, please select the proper power supply cord for the equipment by referring to “ Specifications ” and “ Certified Cord ” below:

CAUTION: In case you use a non-approved power supply cord for Olympus products, Olympus can no longer warrant the electrical safety of the equipment.

Specifications

Voltage Rating	125V AC (for 100-120V AC area) or, 250V AC (for 220-240V AC area)
Current Rating	6A minimum
Temperature Rating	60°C minimum
Length	3.05 m maximum
Fittings Configuration	Grounding type attachment plug cap. Opposite terminates in molded-on IEC configuration appliance coupling.

Table 1 Certified Cord

A power supply cord should be certified by one of the agencies listed in Table 1 , or comprised of cordage marked with an agency marking per Table 1 or marked per Table 2. The fittings are to be marked with at least one of agencies listed in Table 1. In case you are unable to buy locally in your country the power supply cord which is approved by one of the agencies mentioned in Table 1, please use replacements approved by any other equivalent and authorized agencies in your country.













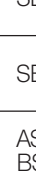





Country	Agency	Certification Mark	Country	Agency	Certification Mark
Argentina	IRAM		Italy	IMQ	
Australia	SAA		Japan	JET, JQA, TÜV, UL-APEX / MITI	
Austria	ÖVE		Netherlands	KEMA	
Belgium	CEBEC		Norway	NEMKO	
Canada	CSA		Spain	AEE	
Denmark	DEMKO		Sweden	SEMKO	
Finland	FEI		Switzerland	SEV	
France	UTE		United Kingdom	ASTA BSI	
Germany	VDE		U.S.A.	UL	
Ireland	NSAI				

Table 2 HAR Flexible Cord

APPROVAL ORGANIZATIONS AND CORDAGE HARMONIZATION MARKING METHODS

Approval Organization	Printed or Embossed Harmonization Marking (May be located on jacket or insulation of internal wiring)		Alternative Marking Utilizing Black-Red-Yellow Thread (Length of color section in mm)		
			Black	Red	Yellow
Comite Electrotechnique Belge (CEBEC)	CEBEC	<HAR>	10	30	10
Verband Deutscher Elektrotechniker (VDE) e.V. Prüfstelle	<VDE>	<HAR>	30	10	10
Union Technique de l'Electricite' (UTE)	USE	<HAR>	30	10	30
Instituto Italiano del Marchio di Qualita' (IMQ)	IEMMEQU	<HAR>	10	30	50
British Approvals Service for Electric Cables (BASEC)	BASEC	<HAR>	10	10	30
N.V. KEMA	KEMA-KEUR	<HAR>	10	30	30
SEMKO AB Svenska Elektriska Materielkontrollanstalter	SEMKO	<HAR>	10	10	50
Österreichischer Verband für Elektrotechnik (ÖVE)	<ÖVE>	<HAR>	30	10	50
Danmarks Elektriske Materialkontroll (DEMKO)	<DEMKO>	<HAR>	30	10	30
National Standards Authority of Ireland (NSAI)	<NSAI>	<HAR>	30	30	50
Norges Elektriske Materielkontroll (NEMKO)	NEMKO	<HAR>	10	10	70
Asociacion Electrotecnica Y Electronica Espanola (AEE)	<UNED>	<HAR>	30	10	70
Hellenic Organization for Standardization (ELOT)	ELOT	<HAR>	30	30	70
Instituto Portages da Qualidade (IPQ)	np	<HAR>	10	10	90
Schweizerischer Elektro Technischer Verein (SEV)	SEV	<HAR>	10	30	90
Elektriska Inspektoratet	SETI	<HAR>	10	30	90

Underwriters Laboratories Inc. (UL)
Canadian Standards Association (CSA)

SV, SVT, SJ or SJT, 3 X 18AWG
SV, SVT, SJ or SJT, 3 X 18AWG

MEMO

MEMO

OLYMPUS

OLYMPUS CORPORATION

2-43-2, Hatagaya, Shibuya-ku, Tokyo, Japan

OLYMPUS EUROPA GMBH

Postfach 10 49 08, 20034, Hamburg, Germany

OLYMPUS AMERICA INC.

2 Corporate Center Drive, Melville, NY 11747-3157, U.S.A.

OLYMPUS INDUSTRIAL AMERICA, INC.

One Corporate Drive, Orangeburg, NY 10962, U.S.A.

OLYMPUS SINGAPORE PTE LTD.

491B River Valley Road, #12-01/04 Valley Point Office Tower, Singapore 248373

OLYMPUS UK LTD.

2-8 Honduras Street, London EC1Y 0TX, United Kingdom.

OLYMPUS AUSTRALIA PTY. LTD.

31 Gilby Road, Mt. Waverley, VIC 3149, Melbourne, Australia.

