

OLYMPUS[®]

Optional Module

SZX2-ILR66

SZX2-RHS

INSTRUCTIONS

LED FOUR-PART RING ILLUMINATOR SYSTEM

This instruction manual is for the Olympus LED Four-Part Ring Illuminator System. To ensure safety, obtain optimum performance, familiarize yourself fully with the use of this equipment, we recommend that you study this manual thoroughly before operating the microscope. Retain this instruction manual in an easily accessible place near the work desk for future reference.



A X 7 5 5 9

CONTENTS

	Page
IMPORTANT – Be sure to read this chapter for safe use of the equipment. –	1-4
1 SYSTEM CHART	5
2 NOMENCLATURE	6
3 ASSEMBLY	7-10
1 Attaching the LED Four-Part Illuminator SZX2-ILR66	7-9
2 Attaching the Cable and Power Cord	10
4 OPERATION	11
1 Adjusting the Brightness	11
2 Using the Control Buttons of the Hand Switch	12
3 Illumination Performance Per Objective and Microscope	13-15
5 SPECIFICATIONS	16,17
■ PROPER SELECTION OF THE POWER SUPPLY CORD	18-21

IMPORTANT



SAFETY PRECAUTIONS

1. Always use the power cord provided by Olympus.
2. Always **ground** the SZX2-RHS Hand Switch.
3. The SZX2-RHS Hand Switch incorporates high-voltage parts inside. Do not open the cover of this unit to prevent electric shock.

Notes on the LED (Light Emitting Diode) Safety

The LED built into the SZX2-ILR66 LED Four-Part Ring Illuminator is categorized a Class 1 LED product by the following standards. It is basically safe but it is discommended to stare at the light from the LED Four-Part Ring Illuminator for a long period as this could damage your eye.

CLASS 1 LED PRODUCT (IEC60825-1: 1993+A1: 1997+A2: 2001)

Safety Symbols

The following symbols are found on the SZX2-RHS Hand Switch. Study the meaning of the symbols, and always use the equipment in the safest possible manner.

Symbol	Explanation
	Before use, carefully read the instruction manual. Improper use could result in personal injury to the user and/or damage to the equipment.
	Indicates that the main switch is ON.
	Indicates that the main switch is OFF.

1 Getting Ready

1. The LED Four-Part Ring Illuminator System is a precision instrument. Handle it with care and avoid subjecting it to sudden or severe impact.
2. Do not use the LED Four-Part Ring Illuminator System where it may be subjected to direct sunlight, high temperatures and humidity, dust or vibrations (for the operating environment, see Chapter 5, "SPECIFICATIONS" on page 17).
3. Applicable microscopes are as follows.
SZX16
SZX10/7: Use the SZX-LGR66 adapter.
SZ61/51 series: Use the SZ-LGR66 adapter.
MVX10: Use the SZX-LGR66 adapter.
STM6 series Use the SZX-LGR66 adapter.
4. The full illumination performance cannot be manifested when an optional auxiliary objective for the SZ61/51 series or a low-power objective for the SZX16/10 is used (see pages 13,14 for details).
5. Take the following care when using the STM6 series because measurement accuracy is affected even by slight heat generation of the LED.
If the intensity of the illumination is expected to be changed widely (minimum ↔ maximum) when the measurement is going to take long, keep the illumination in the maximum condition for about an hour before using the system.
6. Variance in phase may be produced due to variance of individual LEDs.

2

Maintenance and Storage

1. Clean the lens components by blowing dirt away with a commercially available blower and then wiping lightly with a piece of cleaning paper (or freshly washed clean gauze). To remove fingerprints or oil smudges, wipe with cleaning paper slightly moistened with commercially available absolute alcohol.
▲ Since the absolute alcohol is highly flammable, it must be handled carefully. Be sure to keep it away from open flames or potential sources of electrical sparks — for example, electrical equipment that is being switched on or off. Also remember to always use it only in a well-ventilated room.
2. Do not use organic solvents to clean the non-lens components. If smudges are difficult to clean, wipe them with a soft cloth slightly moistened with a diluted neutral detergent.
3. Never disassemble any part of the system as this could cause malfunctions or reduced performance.
4. When disposing of this system, be sure to follow your local regulations or ordinances.

3

Caution

If the system equipment is used in a manner not specified by this manual, the safety of the user may be imperiled. In addition, the equipment may also be damaged. Always use the equipment as outlined in the instruction manual.

The following symbols are used to set off text in this instruction manual.

- ▲: Indicates that failure to follow the instructions in the warning could result in bodily harm to the user and/or damage to equipment (including objects in the vicinity of the equipment).
- ★: Indicates that failure to follow the instructions could result in damage to the equipment.
- ⊙: Indicates commentary (for ease of operation and maintenance).

CE Compliance

This device complies with the requirements of both directive **2004/108/EC** concerning electromagnetic compatibility and directive **2006/95/EC** concerning low voltage. The CE marking indicates compliance with the above directives.

FCC

This device has been subjected to the compliance evaluation of the following FCC regulation:

- FCC Part 15, Subpart B: Radio Frequency Equipment (Commercial and industrial areas)

NOTE: This equipment has been tested and found to comply with the limits for a Class A digital device, pursuant to Part 15 of the FCC Rules. These limits are designed to provide reasonable protection against harmful interference when the equipment is operated in a commercial environment. This equipment generates, uses, and can radiate radio frequency energy and, if not installed and used in accordance with the instruction manual, may cause harmful interference to radio communications. Operation of this equipment in a residential area is likely to cause harmful interference in which case the user will be required to correct the interference at his own expense.

FCC WARNING: Changes or modifications not expressly approved by the party responsible for compliance could void the user's authority to operate the equipment.

1 SYSTEM CHART

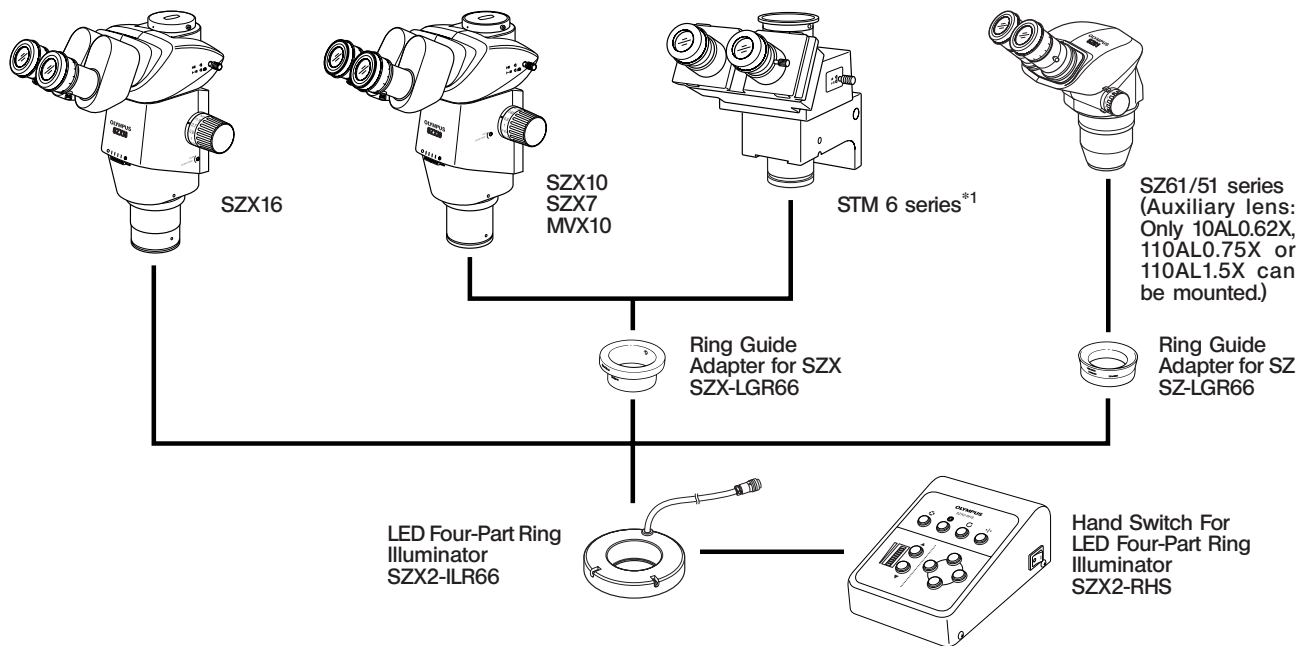

©When the SZX7 and SZ2-ILST are used in combination with this system, the following objectives cannot be used:
DFPL0.5X-4, DFPL0.75X-4, DFPLAPO1X-4, SZX-ACH1X, SZX-ACH1.25X-2.

©When an SZ61/SZX7 series microscope is used with this system, the SZ2-ET cannot be used.

*1When the MM6-VL/MM6C-VL vertical illumination arm is used with the STM6 series, the SZX-LGR66 ring light guide adapter is required for mounting.

2 NOMENCLATURE

**LED Four-Part Ring Illuminator
SZX2-ILR66**

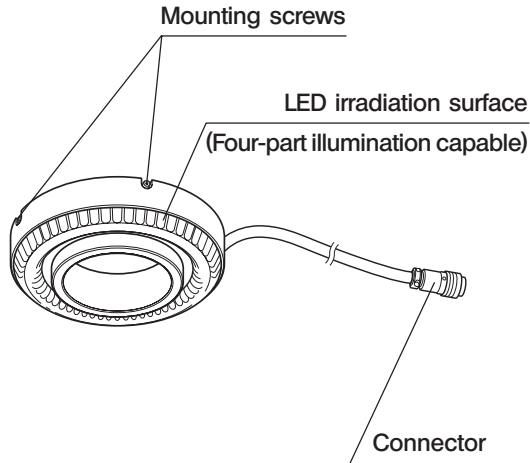

**Hand Switch for LED Four-Part Ring Illuminator
SZX2-RHS**

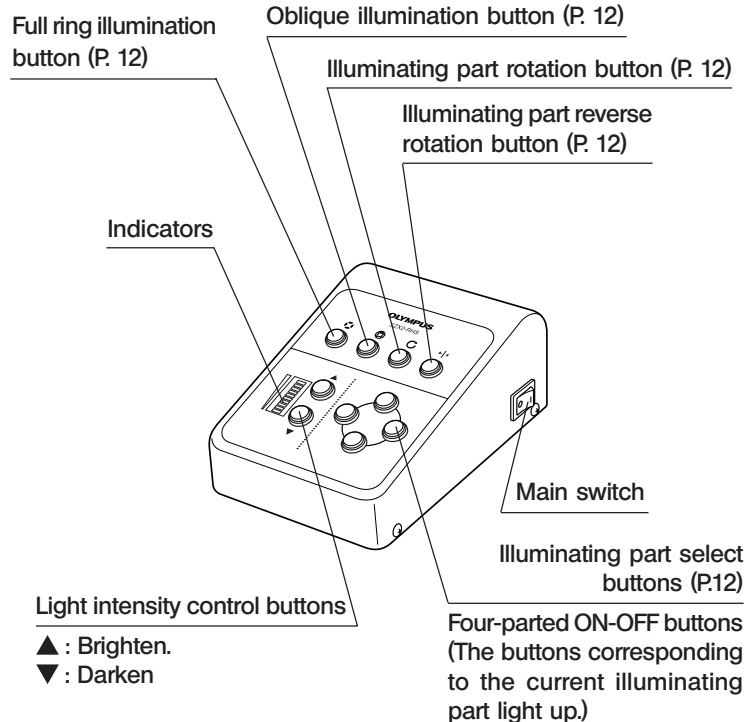

3 ASSEMBLY

1 Attaching the LED Four-Part Illuminator SZX2-ILR66

- ⊙ An adapter is required for mounting on a microscope other than the SZX16.
- ⊙ Attach the SZX2-ILR66 illuminator so that the cable comes on the rear part. Otherwise, the actual illuminating parts of the SZX2-ILR66 will not match the illuminating parts selected with the illuminating part select buttons of the SZX2-RHS hand switch.

Mounting on SZX16 (Fig. 1)

1. Using the Allen screwdriver provided with the microscope, loosen the two clamping screws ② on the SZX2-ILR66 illuminator ①.
2. Fit the SZX2-ILR66 ① all the way into the objective ③ of the SZX16 and tighten the clamping screws ② using the Allen screwdriver.

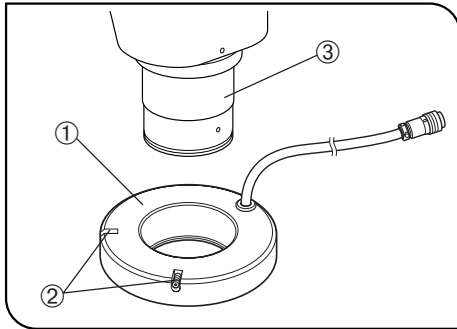

Fig. 1

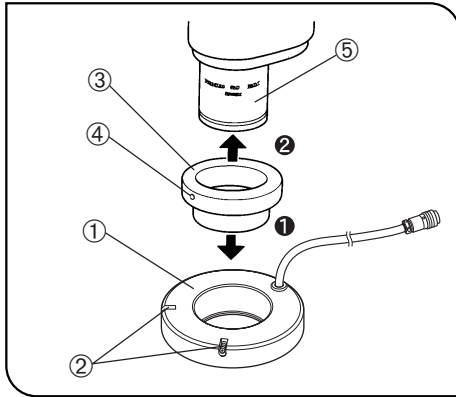

Fig. 2

Mounting on SZX10/7 or MVX10 (Fig. 2)

1. Using the Allen screwdriver provided with the microscope, loosen the two clamping screws ② on the SZX2-ILR66 illuminator ①.
2. Insert the SZX-LGR66 ring light guide adapter ③ all the way into the SZX2-ILR66 ① and tighten the clamping screws ② using the Allen screwdriver.
3. Loosen the clamping screw ④ on the SZX-LGR66 ③ using the Allen screwdriver.
4. Fit the SZX-LGR66 ③ into the objective ③ of the SZX10/7 or MVX10 until the front tip of the SZX-LGR66 ③ is aligned with that of the objective ⑤, and tighten the clamping screw ④ using the Allen screwdriver.

★ **When the DFPLAPO1.5X-4/DFPL2X-4 objective is used, the SZX-LGR66 should be fixed at a position about 10 mm higher than the front tip of the objective in order to obtain optimum illumination.**

★ **When either objective mentioned below is used, the working distance is reduced slightly:**

When the SZX10/7 is used: By 11 mm with the SZX-ACH1X. By 1.5 mm with the SZX-ACH1.25X.

When the MVX10 is used: By 6.5 mm with the MVPLAPO0.63X. By 3.5 mm with the MVPLAPO1X.

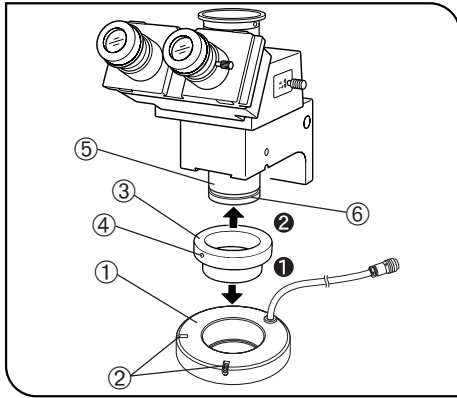

Fig. 3

Mounting on the STM6 Series (Fig. 3)

★ When the MM6-VL/MM6C-VL vertical illumination arm is used with the STM6 series, the SZX-LGR66 ring light guide adapter is required for mounting.

1. Using the Allen wrench provided with the microscope, loosen the two clamping screws ② on the SZX2-ILR66 illuminator ①.
2. Insert the SZX-LGR66 ring light guide adapter ③ all the way into the SZX2-ILR66 ① and tighten the clamping screws ② using the Allen wrench.
3. Loosen the clamping screw ④ on the SZX-LGR66 ③ using the Allen wrench.
4. Fit the SZX-LGR66 ③ into the objective ⑤ of the STM6, align the height of the clamping screw ④ with the positioning groove ⑥, and tighten the clamping screw ④ using the Allen wrench.

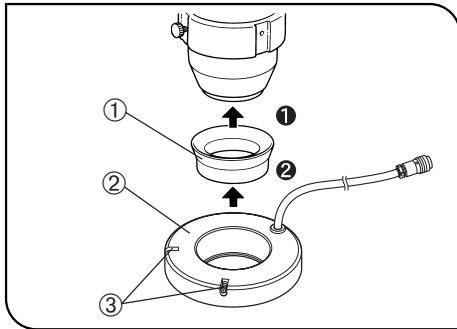

Fig. 4

Mounting on the SZ61/51 Series (Fig. 4)

1. Fit the SZ-LGR66 ring guide adapter ① all the way into the auxiliary objective mount thread section at the front tip of the SZ61/51 microscopes.
 ◎ When an applicable auxiliary objective (110AL0.62X, 110AL0.75X or 110AL1.5X) is mounted, attach the SZ-LGR66 to the front tip of the auxiliary objective.
2. Using the Allen wrench provided with the microscope, loosen the two clamping screws ③ on the SZX2-ILR66 illuminator ②.
3. Fit the SZX2-ILR66 ② all the way into the SZ-LGR66 ① and tighten the clamping screws ③ using the Allen wrench.

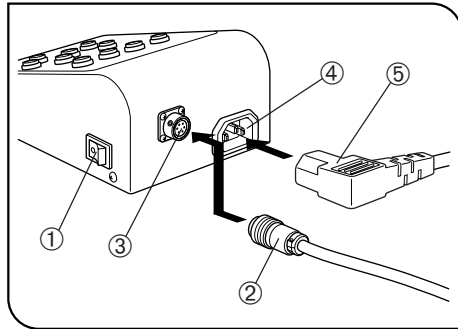

Fig. 5

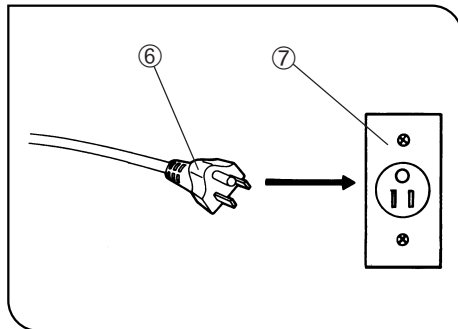

Fig. 6

2 Attaching the Cable and Power Cord

(Figs. 5 & 6)

- ▲Cables and cords are vulnerable to bend or twist. Do not apply excessive force to them.
- ▲Make sure that the main switch ① of the SZX2-RHS is set to “○” (OFF) before connecting the power cord.
- ▲Always use the power cord provided by Olympus. If no power cord is provided, please select the power cord by referring to the section “PROPER SELECTION OF THE POWER SUPPLY CORD” at the end of this instruction manual. If the proper power cord is not used, Olympus can no longer warrant the electrical safety performance of the equipment.

1. Insert the cable connector ② of the SZX2-ILR66 illuminator firmly into the OUTPUT connector ③ on the SZX2-RHS hand switch. (Fig. 5)
2. Insert the connector ⑤ of the power cord into the power cord connector ④ of the SZX2-RHS, and insert the power cord plug ⑥ into the power outlet ⑦.

- ▲Connect the provided power cord correctly and ensure that the grounding terminal of the power supply and that of the 3-conductor wall outlet are properly connected. If the equipment is not grounded, Olympus can no longer warrant the electrical safety performance of the equipment.

- ▲Unplugging the power cord is also used to stop power supply in case of emergency. Set up the Power Supply so that the power cord connector (on the back of the unit) or the power cord plug is within your reach.

4 OPERATION

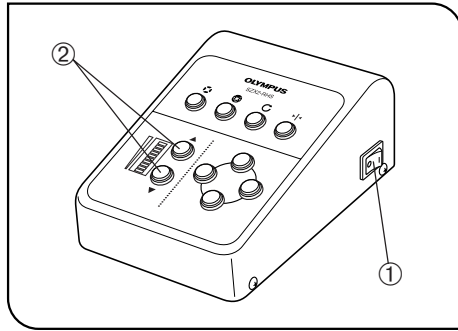

Fig. 7

1 Adjusting the Brightness

(Fig. 7)

1. Press the "I" (ON) segment of the main switch ① of the SZX2-RHS hand switch to turn it ON.
2. Pressing the ▲ light intensity control button ② to increase the brightness, and pressing the ▼ button decreases it.
 - ⊙ Holding a light intensity control button varies the brightness continuously.
 - ⊙ The indicator at the bottom is also used as the pilot lamp. It is lit even when the light intensity is "0" so that the user would not forget turning the hand switch OFF.
 - ⊙ Even if the main switch is set to "O" (OFF) then "I" (ON) again, the last light intensity and illuminating part settings before the main switch is set to "O" (OFF) are recalled.

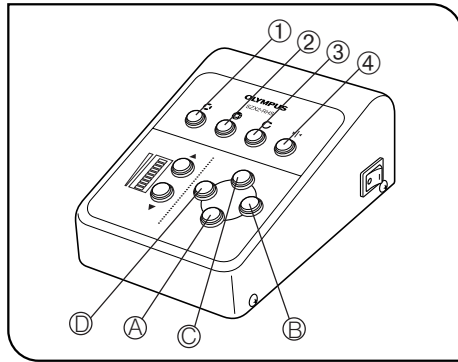

Fig. 8

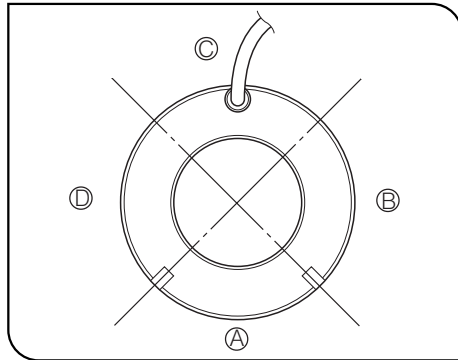

Fig. 9

2 Using the Control Buttons of the Hand Switch (Figs. 8 & 9)

- ① Press to illuminate all of the four parts of the illuminator.
This will offer bright, shadow-free observation images.
- ② Press to illuminate only one of the four parts of the illuminator. (Illumination part ③ is illuminated with the initial setting.)
This provides the specimen with a shadow and offers high-contrast observation images.
This is convenient for stressing the surface irregularities on the specimen.
- ③ Press to move the illuminating part in the clockwise direction.
This changes the shadow on the specimen in sequence and makes it possible to select the optimum illuminating part.
- ④ Press to move the illuminating part in the counterclockwise direction.
- Ⓐ-ⓓ Press one of the buttons to select the desired illuminating part.
(See Fig. 8, 9 for the correspondence between select button Ⓐ to ⓓ and illuminating parts Ⓐ to ⓓ.)

3 Illumination Performance Per Objective and Microscope

©The data shows the range in which observation is possible when the specimen is a light-scattering object.
 Observation may be impossible when the specimen has a highly reflective surface such as a mirror surface.

SZX16

Objective \ Zoom Ratio	0.7	0.8	1	1.25	1.6	2	2.5	3.2	4	5	6.3	8	10	11.5	
SDFPLFL0.3X	LED image may be observed.														
SDFPL0.5XPF			Observation possible.												
SDFPLAPO 0.8X															
SDFPLAPO 1XPF															

©Observation is not possible with the SDFPLAPO 1.6XPF or SDFPLAPO 2XPFC.

SZX10

Objective \ Zoom Ratio	0.63	0.8	1	1.25	1.6	2	2.5	3.2	4	5	6.3	
DFPL0.5X-4	LED image may be observed.		Observation possible.									
DFPL0.75X-4												
DFPLAPO1X-4												
SZX-ACH1X												
DFPLAPO1.25X-4												
SZX-ACH1.25X												
DFPL1.5X-4												
DFPL2X-4												

SZX7

Observation is always possible.

SZX61/51

Auxiliary objective \ Zoom Ratio	0.67	0.8	1	1.2	1.5	2	2.5	3	3.5	4	4.5
110AL0.62X	LED image may be observed.										
110AL0.75X	Observation possible.										
110AL1.5X											

© Observation is not possible with the 110ALK0.3X, 110ALK0.4X, 110AL0.5X or 110AL2X.

 MVX10

Objective \ Zoom Ratio	0.63	0.8	1	1.25	1.6	2	2.5	3.2	4	5	6.3
MVPLAPO0.63X	Observation possible.										
MVPLAPO1X											

© Observation is not possible with the MVPLAPO 2XC.

 STM6

Observation is always possible.

5 SPECIFICATIONS

■ LED Four-Part Ring Illuminator SZX2-ILR66

Item	Specification
LED color	White
Color temperature	Max. 8000K Min. 5000K
Dimensions	φ 120 x 29.5 mm Cable length: 1000 mm
Weight	700 g
Average life	Approx. 20000 hours (Ambient temperature 20°C, light intensity level 50%)

■ Hand Switch For LED Four-Part Ring Illuminator SZX2-RHS

Item	Specification
System	Pulse duty control, 1 circuit
Output current variation	0 to 240 mA
Rated supply voltage	100-240 V AC, 0.2-0.1A, 50/60 Hz
Power consumption	12 W
Dimensions	110 (W) x 160 (D) x 67 (H) mm (excluding projections)
Weight	500 g

■ Common Specifications to SZX2-ILR66/SZX2-RHS

Item	Specification
Operating environment	<ul style="list-style-type: none">• Indoor use• Altitude : Max. 2,000 m• Ambient temperature: 5°C to 40°C (41°F to 104°F)• Maximum relative humidity: 80% for temperatures up to 31°C (88°F) decreasing linearly through 70% at 34°C (93°F), 60% at 37°C (99°F), to 50% relative humidity at 40°C (104°F)• Main supply voltage fluctuations not to exceed $\pm 10\%$ of nominal voltage• Pollution Degree: 2 (in accordance with IEC60664)• Installation/Overvoltage Category: II (in accordance with IEC60664)

■ PROPER SELECTION OF THE POWER SUPPLY CORD

If no power supply cord is provided, please select the proper power supply cord for the equipment by referring to “Specifications” and “Certified Cord” below:

CAUTION: In case you use a non-approved power supply cord for Olympus products, Olympus can no longer warrant the electrical safety of the equipment.

Specifications

Voltage Rating	125V AC (for 100-120V AC area) or, 250V AC (for 220-240V AC area)
Current Rating	6A minimum
Temperature Rating	60°C minimum
Length	3.05 m maximum
Fittings Configuration	Grounding type attachment plug cap. Opposite terminates in molded-on IEC configuration appliance coupling.

Table 1 Certified Cord

A power supply cord should be certified by one of the agencies listed in Table 1, or comprised of cordage marked with an agency marking per Table 1 or marked per Table 2. The fittings are to be marked with at least one of agencies listed in Table 1. In case you are unable to buy locally in your country the power supply cord which is approved by one of the agencies mentioned in Table 1, please use replacements approved by any other equivalent and authorized agencies in your country.



















Country	Agency	Certification Mark	Country	Agency	Certification Mark
Argentina	IRAM		Italy	IMQ	
Australia	SAA		Japan	JET, JQA, TÜV, UL-APEX / MITI	
Austria	ÖVE		Netherlands	KEMA	
Belgium	CEBEC		Norway	NEMKO	
Canada	CSA		Spain	AEE	
Denmark	DEMKO		Sweden	SEMKO	
Finland	FEI		Switzerland	SEV	
France	UTE		United Kingdom	ASTA BSI	
Germany	VDE		USA	UL	
Ireland	NSAI				

Table 2 HAR Flexible Cord

APPROVAL ORGANIZATIONS AND CORDAGE HARMONIZATION MARKING METHODS

Approval Organization	Printed or Embossed Harmonization Marking (May be located on jacket or insulation of internal wiring)		Alternative Marking Utilizing Black-Red-Yellow Thread (Length of color section in mm)		
			Black	Red	Yellow
Comite Electrotechnique Belge (CEBEC)	CEBEC	⟨HAR⟩	10	30	10
Verband Deutscher Elektrotechniker (VDE) e.V. Prüfstelle	⟨VDE⟩	⟨HAR⟩	30	10	10
Union Technique de l'Electricite' (UTE)	USE	⟨HAR⟩	30	10	30
Instituto Italiano del Marchio di Qualita' (IMQ)	IEMMEQU	⟨HAR⟩	10	30	50
British Approvals Service for Electric Cables (BASEC)	BASEC	⟨HAR⟩	10	10	30
N.V. KEMA	KEMA-KEUR	⟨HAR⟩	10	30	30
SEMKO AB Svenska Elektriska Materielkontrollanstalter	SEMKO	⟨HAR⟩	10	10	50

Österreichischer Verband für Elektrotechnik (ÖVE)	⟨ÖVE⟩	⟨HAR⟩	30	10	50
Danmarks Elektriske Materialkontroll (DEMKO)	⟨DEMKO⟩	⟨HAR⟩	30	10	30
National Standards Authority of Ireland (NSAI)	⟨NSAI⟩	⟨HAR⟩	30	30	50
Norges Elektriske Materiellkontroll (NEMKO)	NEMKO	⟨HAR⟩	10	10	70
Asociacion Electrotecnica Y Electronica Espanola (AEE)	⟨UNED⟩	⟨HAR⟩	30	10	70
Hellenic Organization for Standardization (ELOT)	ELOT	⟨HAR⟩	30	30	70
Instituto Portages da Qualidade (IPQ)	np	⟨HAR⟩	10	10	90
Schweizerischer Elektro Technischer Verein (SEV)	SEV	⟨HAR⟩	10	30	90
Elektriska Inspektoratet	SETI	⟨HAR⟩	10	30	90

Underwriters Laboratories Inc. (UL)
Canadian Standards Association (CSA)

SV, SVT, SJ or SJT, 3 X 18AWG
SV, SVT, SJ or SJT, 3 X 18AWG

MEMO

MEMO

OLYMPUS®



OLYMPUS CORPORATION

Shinjuku Monolith, 3-1, Nishi Shinjuku 2-chome, Shinjuku-ku, Tokyo, Japan



OLYMPUS LIFE SCIENCE EUROPA GMBH

Postfach 10 49 08, 20034, Hamburg, Germany

OLYMPUS AMERICA INC.

3500 Corporate Parkway, P.O. Box 610, Center Valley, PA 18034-0610, U.S.A.

OLYMPUS UK LIMITED

Vision House, 19 Colonial Way, Watford, Hertfordshire, WD24 4JL, UK

OLYMPUS SURGICAL & INDUSTRIAL AMERICA INC.

One Corporate Drive, Orangeburg, NY 10962, U.S.A.

OLYMPUS SINGAPORE PTE LTD.

491B River Valley Road, #12-01/04 Valley Point Office Tower, Singapore 248373

OLYMPUS AUSTRALIA PTY. LTD.

31 Gilby Road, Mount Waverley, VIC., 3149, Australia

OLYMPUS LATIN AMERICA, INC.

5301 Blue Lagoon Drive, Suite 290 Miami, FL 33126, U.S.A.

