

# OLYMPUS®

---

**SZX2-ILLK**  
**SZX2-ILLB**  
**SZX2-ILLD**  
**SZX2-AN**  
**SZX-PO**  
**SXH-CLJ**  
**SZX-CL**  
**SZX-TLGAD**  
**LG-SF**

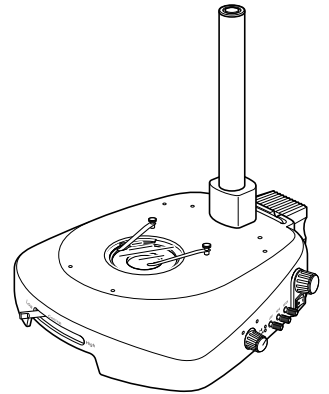

## INSTRUCTIONS

---

### SZX2 ILLUMINATOR STAND

This instruction manual is for the Olympus SZX2 Illuminator Stand. To ensure the safety, obtain optimum performance and to familiarize yourself full with the use of this equipment, we recommend that you study this manual thoroughly before operating the microscope. Retain this instruction manual in an easily accessible place near the work desk for future reference.



A X 7 5 3 3



This device complies with the requirements of directive 98/79/EC concerning in vitro diagnostic medical devices. CE marking means the conformity to the directive.

**NOTE:** This equipment has been tested and found to comply with the limits for a Class A digital device, pursuant to Part 15 of the FCC Rules. These limits are designed to provide reasonable protection against harmful interference when the equipment is operated in a commercial environment. This equipment generates, uses, and can radiate radio frequency energy and, if not installed and used in accordance with the instruction manual, may cause harmful interference to radio communications. Operation of this equipment in a residential area is likely to cause harmful interference in which case the user will be required to correct the interference at his own expense.

**FCC WARNING:** Changes or modifications not expressly approved by the party responsible for compliance could void the user's authority to operate the equipment.

# CONTENTS

Correct assembly and adjustments are indispensable for the microscope to manifest its full performance. If you want to assemble the microscope by yourself, read Chapter 6, "ASSEMBLY" (pages 19 to 23) first.

**IMPORTANT – Be sure to read this section for safe use of the equipment. – 1-4**

## 1 NOMENCLATURE 5

## 2 OPERATION 6-10

<b>1</b>	Aligning the Light Axis .....	6
<b>2</b>	Applicable Objectives .....	7
<b>3</b>	Built-in Filters <b>ILLB</b> .....	8
<b>4</b>	Optional Filters .....	8
<b>5</b>	Oblique Illumination Adjustment Knobs <b>ILLB</b> <b>ILLK</b> .....	9
<b>6</b>	Contrast Selector Lever <b>ILLB</b> .....	10
<b>7</b>	Brightfield/Darkfield Selector Lever <b>ILLD</b> .....	10
<b>8</b>	Photomicrography (Adjusting the Color Temperature) .....	10

## 3 SPECIFICATIONS 11

## 4 TROUBLESHOOTING GUIDE 12,13

## 5 OPERATION OF OTHER MODULES 14-18

5-1	Analyzer SZX2-AN and Polarizer SZX-PO .....	14,15
5-2	Jewel Observation Clip SZH-CLJ .....	16
5-3	Large Clear Center Plate SZX-CL .....	17
5-4	Transmitted Light Guide Adapter SZX-TLGAD and Flexible Light Guide LG-SF .....	18

## 6 ASSEMBLY 19-23

■	PROPER SELECTION OF THE POWER SUPPLY CORD .....	24,25
---	---	-------

## 7 LAMP SOCKET INSPECTION SHEET 26

# IMPORTANT

This manual pertains only to the operation of the illuminator stand. Please also read the instruction manuals for the SZX16/SZX10 stereo microscope and other options to understand the comprehensive operating instructions of the microscope system.

This manual describes the SZX2 illuminator stands together, but these products are actually given different specifications as shown in the following table.

Item \ Illuminator stand	Transmitted light illuminator stand SZX2-ILLK	High-class transmitted light illuminator stand SZX2-ILLB	Brightfield/darkfield illuminator stand SZX2-ILLD
Max. illumination area	$\phi$ 40 mm (1X or higher-power objective)		$\phi$ 40 mm: Brightfield illumination $\phi$ 35 mm: Darkfield illumination
Brightfield illumination	Possible	Possible	
Darkfield illumination	Not possible		Possible
Oblique illumination	Possible		Not possible
Build-in filters	Not possible	LBD, ND6 and ND25 x 1 each	LBD (Brightfield only)
Illumination light source	6 V, 30 W halogen bulb		

◎The optional light guide illuminator can be used. (SZX2-ILLK/ILLB only)

## SAFETY PRECAUTIONS

- After the equipment has been used in an observation of a specimen that is accompanied with a potential of infection, clean the parts coming in contact with the specimen to prevent infection.
  - Moving the illuminator stand is accompanied with the risk of dropping the specimen. Be sure to remove the specimen before moving the illuminator stand.
  - In case the specimen is damaged by erroneous operation, promptly take the infection prevention measures.
  - The microscope may become unstable if its height is increased by the microscope and accessory mounted on the illuminator stand. In this case, take anti-toppling measures to prevent the specimen from being dropped when the microscope system topples down.
- The SZX2-ILLK/ILLB illuminator stand generates heat because it incorporates the light source bulb. To ensure heat radiation, reserve a distance of at least 10 cm behind the lamp socket on the rear of the illumination stand from any obstacle, and take care not to block the air vents.
- The SZX2-ILLD illuminator stand incorporates the light source valve at the bottom and should be installed on a flat surface without placing any flammable object on it. If the illumination stand is installed on a soft surface, it may sink into the surface and a fire hazard may result.
- Never insert a metallic object into an air vent. Otherwise, electric shock or malfunction may result.

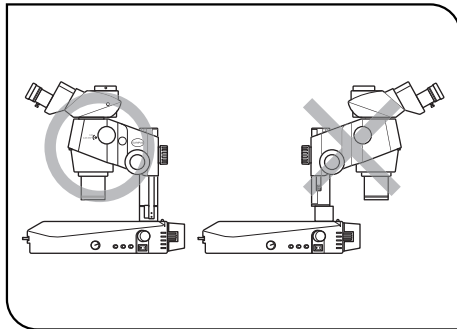

Fig. 1

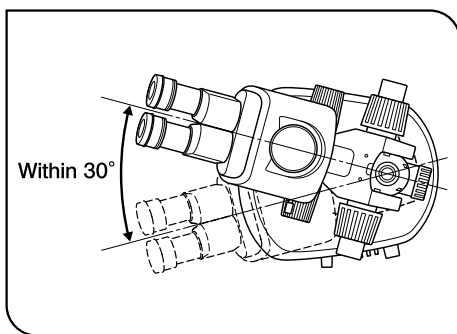

Fig. 2

5. To prevent the microscope system from turning over, always install the microscope body in the orientation as shown with the O marking in the figure on the left, and its left-right pivot angle must be limited to 30°.

(Figs. 1 & 2)

6. Always use the power cord provided by Olympus. If no power cord is provided, please select the power cord by referring to the section “PROPER SELECTION OF THE POWER SUPPLY CORD” at the end of this instruction manual. If the proper power cord is not used, Olympus can no longer warrant the electrical safety performance of the equipment.

7. Always apply the power of the specified rated voltage. Otherwise, Olympus can no longer warrant the electrical safety performance of the equipment.

8. Always ensure that the grounding terminal is properly **grounded/earthed**. If the equipment is not grounded, Olympus can no longer warrant the electrical safety performance of the equipment.

9. To avoid potential shock hazards and burns when replacing the bulb, make sure that the main switch is set to “O” (OFF), the power cord is unplugged from the outlet, and that the lamp bulb and the area around the lamp socket have cooled sufficiently.

Applicable bulb	Halogen bulb:6V30WHAL (Philips 5761)
-----------------	--------------------------------------

10. If water or a liquid is spilt on the top of the illuminator stand, treat it quickly and promptly as described in “**2 Maintenance and Storage**” below.

11. The standard service life of the lamp socket is 8 (eight) years of use or 20,000 hours of total power ON period, whichever is the shorter period. For details, see Inspection Sheet on page 26.

### Safety Symbols

The following symbols are found on the equipment. Study the meaning of the symbols and always use the equipment in the safest possible manner.

Symbol	Explanation
	Indicates that the surface becomes hot, and should not be touched with bare hands.
	Before use, carefully read the instruction manual. Improper use could result in personal injury to the user and/or damage to the equipment.
	Indicates that the main switch is ON.
	Indicates that the main switch is OFF.

### Warning Indications and Labels

Warning indications and labels related are attached to the parts that should be handled with special care on the equipment. Always heed the warnings.

Warning indication position	Lamp socket (High-temperature warning)	
Warning label position	Rear panel (High-temperature warning)	

When a warning label becomes dirty or is peeled off, contact Olympus for replacement.

## 1 Getting Ready

1. The illuminator stand is a precision instrument. Handle it with care and avoid subjecting it to sudden or severe impact.
2. Do not use the equipment where it is subjected to direct sunlight, high temperature and humidity, or vibration. (For the operating environment, see Chapter 3, "SPECIFICATIONS" on page 11.)
3. When using the SZH-P400/P600 auxiliary pillar (i.e. when using an objective with a long WD or observing a thick specimen), take care of the stability of the microscope so that it does not topple down.  
(Be sure to use the SZX-R drop prevention collar.)

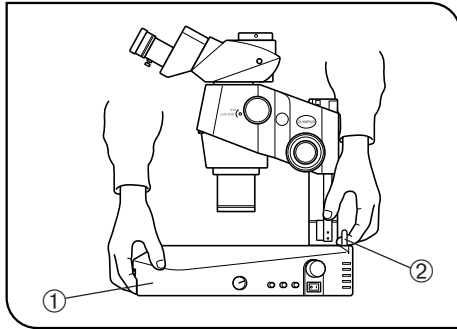

Fig. 3

4. Before moving the illuminator stand, remove any module attached to it to minimize the weight.
  - Set the main switch of the illuminator stand to "○" (OFF), wait until the lamp housing cools down, and then remove the lamp housing from the illuminator stand. (SZX2-ILLK/ILLB)
  - Confirm that the grip handle ② is not hot.
  - Hold the illuminator stand by the finger hook ① on the front and by the grip handle ②. If the illuminator stand is held otherwise, it may drop.
5. Do not apply an excessive force beyond the stopper mechanism of each control. Otherwise, the control may be damaged.
6. If the transmitted light is glaring, use the optional SZX2-CCV or SZX-CCV antiglare plate (see page 23 for how to install it).

## 2 Maintenance and Storage

1. To clean the lenses and other glass components, simply blow dirty away using a commercially available blower and wipe gently using a piece of cleaning paper (or clean gauze).  
If a lens is stained with fingerprints or oil smudges, wipe it gauze slightly moistened with commercially available absolute alcohol.
  - ▲ **Since the absolute alcohol is highly flammable, it must be handled carefully.**  
**Be sure to keep it away from open flames or potential sources of electrical sparks – for example, electrical equipment that is being switched on or off.**  
**Also remember to always use it only in a well-ventilated room.**
2. Do not use organic solvents to clean non-optical components. If smudges are difficult to clean, wipe them with a soft cloth slightly moistened with a diluted neutral detergent.
3. The stage surface is provided with a simplified waterproof construction. If water is spilt on it, promptly set the main switch to "○" (OFF), unplug the power cord and wipe with a dry cloth. Also remove the stage glass and wipe the window lens and the surroundings with a piece of soft gauze, etc.
  - ▲ **If water penetrates inside the equipment, contact Olympus to have the electrical safety checked.**
4. When darkfield illumination (available only with the SZX2-ILLD) is used, the contrast deteriorates considerably if the waterproof glass or stage glass is dirty. Be careful not to stain these parts (particularly during filter mounting or dismounting) and clean them whenever they are stained.
5. Do not disassemble any part of the equipment as this could result in malfunction or reduced performance.
6. When not using the equipment, keep it covered with the dust cover provided.  
Be sure to set the main switch to "○" (OFF) and ensure that the lamp socket has cooled down before covering it.
7. This illuminator stand should be disposed of by following the rules and regulations of your national or local government.

### 3 Caution

If the equipment is used in a manner not specified by this manual, the safety of the user may be imperiled. In addition, the equipment may also be damaged. Always use the equipment as outlined in this instruction manual.

The following symbols are used to set off text in this instruction manual.

- ▲: Indicates that failure to follow the instructions in the warning could result in bodily harm to the user and/or damage to equipment (including objects in the vicinity of the equipment).
- ★: Indicates that failure to follow the instructions could result in damage to equipment.
- ◎: Indicates commentary (for ease of operation and maintenance).

### 4 Intended use

This instrument has been designed to be used to observe magnified images of specimens in routine and research applications.

Do not use this instrument for any purpose other than its intended use.

# 1 NOMENCLATURE

©The following illustration shows the SZX2-ILLB.

If you have not yet assembled the illumination stand, see pages 19 to 23 first.

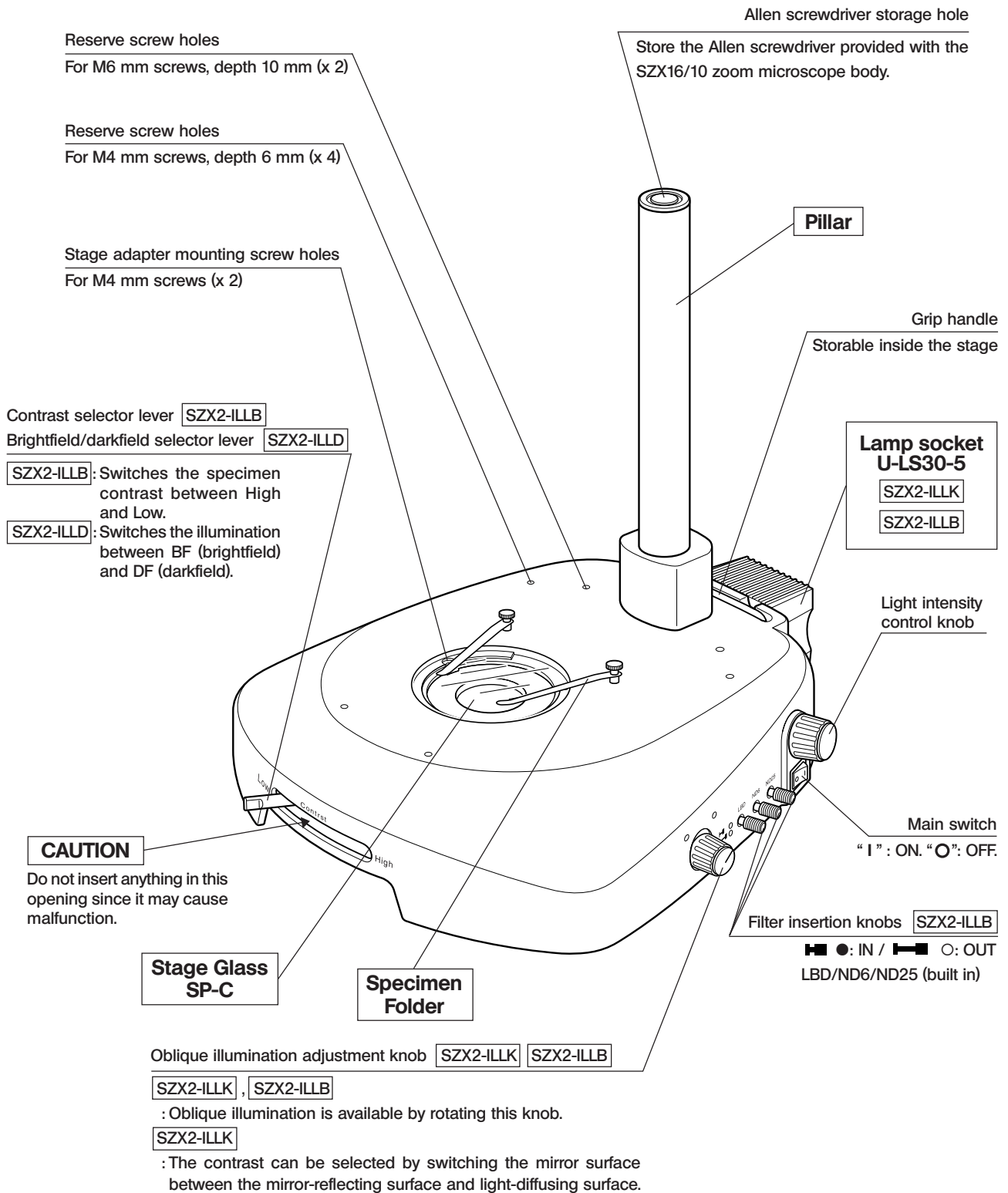

# 2 OPERATION

©When the illuminator stand model name enclosed in  is placed near the headline of a description, the description pertains only to that model.  
 The descriptions without the model name enclosed in  are applicable to all models.

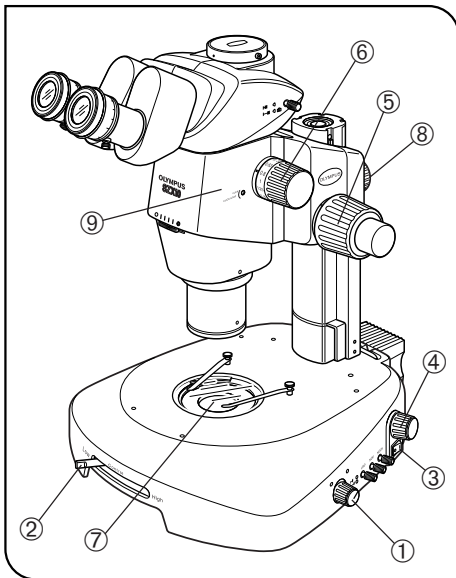

Fig. 4

## 1 Aligning the Light Axis (Fig. 4)

★ This operation is critical for eliminating irregularities and obscuring of illumination. Be sure to perform it correctly.

1. Set the illuminator stand for transmitted light brightfield observation.

Control	Position for transmitted light brightfield observation
<input type="checkbox"/> Oblique illumination adjustment knob ①	Furthest position towards the ○ indication.
<input type="checkbox"/> Oblique illumination adjustment knob ①	Position in which the index points straight up.
<input type="checkbox"/> Contrast selector lever ②	High or Low end position.
<input type="checkbox"/> Brightfield/darkfield selector lever ②	BF end position.

1. Set the main switch ③ to "I" (ON).
2. Rotate the light intensity control knob ④ clockwise for optimum brightness.
3. Rotate the coarse adjustment knob ⑤ to raise the microscope body to the highest position.
4. Rotate the zooming knob to the minimum zoom magnification, and look into the eyepieces to see the window lens frame ⑦ of the illuminator stand.
5. Loosen the focusing assembly clamping knob ⑧, move the microscope body ⑨ to the left and right to make an adjustment so that there is no deviation of the window lens frame ⑦ in the fields of view of the left and right eyepieces, and then tighten the clamping knob ⑧.

## 2 Applicable Objectives

Microscope Body	Objective	SZX2 Illuminator Stand (○:Zoom observation possible in all magnifications. ≥●●X:Zoom observation possible at ●●X or more)					
		SZX2-ILLK		SZX2-ILLB		SZX2-ILLD	
		Oblique illumination control		Contrast selector lever		Brightfield/darkfield selector lever	
		Mirror surface	Diffusion surface	Low	High	DF	BF
SZX16	SDFPLFL0.3X	≥2.5X	≥2.5X	≥2X	≥2X	≥2X	≥2X
	SDFPLAPO0.5XPF	≥1.25X	≥1.25X	≥1.25X	≥1.25X	≥1.6X	≥1.25X
	SDFPLAPO0.8X	≥0.8X	≥0.8X	≥0.8X	≥0.8X	≥1X	≥0.8X
	SDFPLAPO1XPF	○	○	○	○	○	○
	SDFPLAPO1.6XPF (*2)	≥4X	≥1.6X	≥1.6X	≥1.6X	≥1.6X (*1)	≥1.6X
	SDFPLAPO2XPFC (*2)	≥5X	≥2X	≥2X	≥5X	≥2.5X (*1)	≥2X
SZX16 + RFA16	SDFPLFL0.3X	≥2X	≥2X	≥2X	≥2X	≥2X	≥2X
	SDFPLAPO0.5XPF	≥1.6X	≥1.25X	≥1.25X	≥1.25X	≥1.6X	≥1.25X
	SDFPLAPO0.8X	≥0.8X	≥0.8X	≥0.8X	≥0.8X	≥1X	≥0.8X
	SDFPLAPO1XPF	○	○	○	○	○	≥0.8X
	SDFPLAPO1.6XPF	≥1.6X	≥1.6X	≥1.6X	≥1.6X	≥1.6X (*1)	≥1.6X
	SDFPLAPO2XPFC (*2)	≥5X	≥2.5X	≥3.2X	≥2.5X	≥2.5X (*1)	≥2.5X
SZX10	DFPL0.5X-4	≥1.25X	≥1.25X	≥1.25X	≥1.25X	≥1.6X	≥1.25X
	DFPL0.75X-4	≥1X	≥1X	≥0.8X	≥0.8X	≥1X	≥0.8X
	DFPLAPO1X-4	○	○	○	○	○	○
	SZX-ACH1X	○	○	○	○	○	○
	DFPLAPO1.25X	○	○	○	○	○	○
	SZX-ACH1.25X	○	○	○	○	○	○
	DFPL1.5X-4	○	○	○	○	○	○
	DFPL2X-4 (*2)	≥3.2X	○	○	○	○	○
MVX10	MVPLAPO0.63X			≥1X	≥1X	≥1X	≥1X
	MVPLAPO1X			○	○	○	○
	MVPLAPO2XC			○(*3)	—	○(*4)	○

The SDFPLAPO1.6XPF and SDFPLAPO2XPFC have thin tips for facilitating work. As a result, the two extremities of the visual field (right end of the right-eye field and left end of the left-eye field) are cut off at low zoom magnifications.

(\*1): Combination of the SDFPLAPO1.6XPF/SDFPLAPO2XPFC and darkfield illumination:

Flare may be observed on the two extremities of the visual field (right end of the right-eye field and left end of the left-eye field) with certain specimens. If this happens, the flare can be eliminated and the contrast can be improved by stopping down the aperture iris diaphragm of the zoom microscope body.

(\*2): Combination of a high-power objective and transmitted light observation

When the SZX2-ILLB or SZX2-ILLK is used, the edges of the field of view may look obscured. This may be made less noticeable by selecting the Low contrast or using the diffusion surface respectively.

(\*3): Shading may occur in the peripheral part of the field at lower zoom magnifications.

(\*4): Flaring may occur in the peripheral part of the field at lower zoom magnifications.

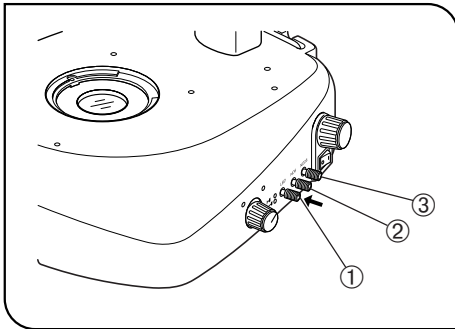

Fig. 5

**3 Built-in Filters** ILLB (Fig. 5)

◎ The SZX2-ILLB incorporates three filters.

1. Pushing in the filter insertion knobs ①, ② & ③ engages the filters in the corresponding light paths.

**Filter types**

SZX2-ILLB	
①	LBD (Color temperature adjustment filter)
②	ND6 (Neutral density filter for brightness adjustment, light transmittance 6%)
③	ND25 (Neutral density filter for brightness adjustment, light transmittance 25%)

◎ Using both the ND6 and ND25 filters renders the light transmittance to 1.5%.

**4 Optional Filters** (Fig. 6)

◎ In addition to the built-in filters, filters with  $\phi 45$  mm diameter can be inserted below the stage glass. (Maximum filter stack height: 5 mm)

◎ Use a frosted filter when you want to observe a dyed tissue specimen, etc. in details under highly regular illumination. (It cannot be used with oblique information.)

It also helps eliminate the illumination irregularities under low magnifications.

1. Remove the stage glass ①.
2. Check the filter(s) for dirt and stain. If it is dirty or stained, clean it.
3. Place the filter(s).

ILLK ILLB

Gently place the filter ② in the filter holder of the window lens section ④.

ILLD

Put the filter ② in the filter adapter ③ and gently place the adapter with filter in the filter holder of the waterproof glass section ④.

★ Since the filter adapter is used for filter mounting, the illuminated area and brightness in darkfield observation are limited.

◎ When taking out filter(s), pinch each filter at the notch ⑤ of the window lens or waterproof glass section ④.

★ Be careful not to leave fingerprints on the filters.

4. Place the stage glass ① in the original position.

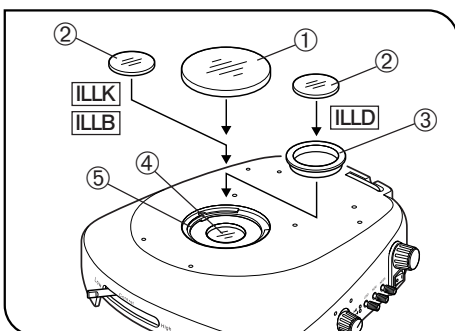

Fig. 6

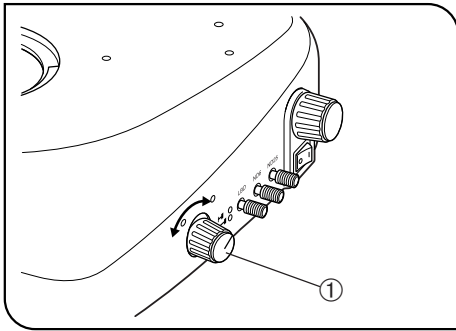

Fig. 7

## 5 Oblique Illumination Adjustment Knobs ILLB ILLK (Fig. 7)

ILLB ILLK

☉ The oblique illumination adjustment knob makes it possible to observe a transparent, clean object by giving certain contrast to it.

1. Rotate the oblique illumination adjustment knob ① to find the position that matches the observed specimen and observation magnification.

★ **The illumination may be obscured under low magnifications.**

2. When not using the oblique illumination.

ILLB: Turn the knob until the index is positioned in furthest position towards the O indication.

ILLK: Set the knob so that the index points straight up or down.

ILLK

☉ The oblique illumination adjustment knob makes it possible to adjust the contrast.

1. Rotate the oblique illumination adjustment knob ①.
  - When the index on the knob points straight up, the mirror is set to the reflecting surface so the contrast is increased.
  - When the index on the knob points straight down, the mirror is set to the light-diffusing surface so the contrast is decreased but at the same time the irregularities in illumination are reduced.

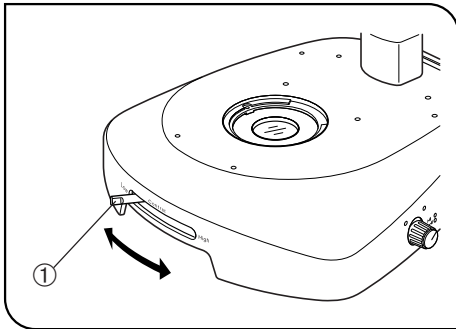

Fig. 8

**6 Contrast Selector Lever** ILLB (Fig. 8)

Ⓞ In general, the contrast is higher when this lever is in the “High” position than when it is in the “Low” position.  
However, the ease of observation is variable depending on the conditions of the specimen. Switch this lever to both positions and select the better position.

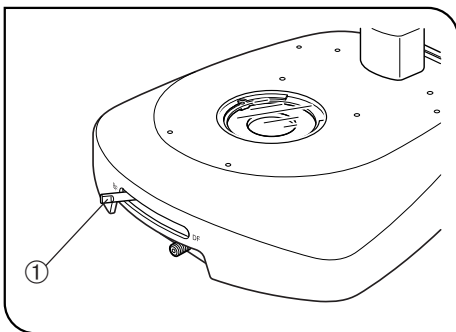

Fig. 9

**7 Brightfield/Darkfield Selector Lever** ILLD (Fig. 9)

**(BF: Transmitted light brightfield observation)**

- Move the lever ① all the way to the “BF” position until it is stopped. This engages the LBD filter in the light path.

**(DF: Transmitted light darkfield observation)**

- Move the lever ① all the way to the “DF” position until it is stopped.

★ In darkfield observation, the stage glass, waterproof glass or stained filter(s) may hinder observation.

In this case, clean the above parts by referring to “**4** Optional Filters.”

When the filter adapter with filter(s) is placed below the stage glass, the illumination area is limited.

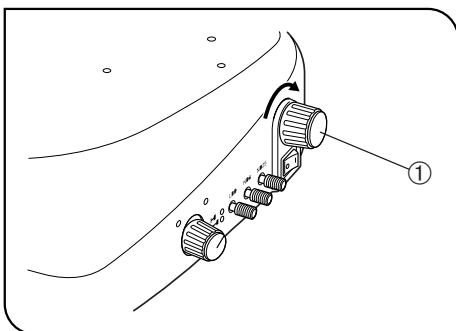

Fig. 10

**8 Photomicrography (Adjusting the Color Temperature)** (Fig. 10)

Ⓞ What is important for color photomicrography is to engage the LBD color temperature adjustment filter and to set the light intensity control knob properly.

1. Engage the color temperature adjustment filter in the light path.

ILLB : Engage the LBD filter built into the stage in the light path.

ILLK : Place the provided 45LBD-IF filter below the stage glass.

2. Set the light intensity control knob ① to the maximum position.

If the picture taken under this condition is bluish, reduce the light intensity control knob ① slightly (see page 13).

3. If it is required to adjust the brightness after setting the light intensity control knob, use the built-in or optional ND filter(s).

Ⓞ When a digital camera is used for photomicrography, the brightness can also be adjusted using the color temperature adjustment (white balance control) of the camera.

# 3 SPECIFICATIONS

Item	Specifications		
	SZX2-ILLK	SZX2-ILLB	SZX2-ILLD
Light source	6 V, 30 W halogen bulb:6V30W/30W: Philips 5761 (Average bulb life: Approx. 100 hours under normal use)		
Light intensity control	Continuously variable (with a built-in transformer). A cooling fan built in.		
Effective illumination field	$\phi$ 40 mm dia.		$\phi$ 40 mm (brightfield), $\phi$ 35 mm (darkfield)
Built-in filters	—	LBD,ND6, ND25: x1 each	LBD (Brightfield only)
Option filters	$\phi$ 45 mm filters can be mounted (max. stacking height: 5 mm). [ILLK] : $\phi$ 45 mm color temperature adjustment filter 45LBD-IF provided.		
Illumination type	<ul style="list-style-type: none"> <li>• Transmitted light brightfield illumination</li> <li>• Oblique illumination</li> </ul>		<ul style="list-style-type: none"> <li>• Transmitted light brightfield illumination</li> <li>• Transmitted light darkfield illumination</li> </ul>
Contrast switching	Position of the oblique illumination adjustment knob.	High/Low position of the contrast selector lever.	—
Pillar height	270 mm		
Base dimensions	340(W) x 347(D) x 82(H) mm		
Weight	4.6 kg	5 kg	5.4 kg
Rated voltage	100-120/220-240 V AC, 0.9/0.5 A, 50/60 Hz		
Operating environment	<ul style="list-style-type: none"> <li>• Indoor use.</li> <li>• Altitude: Max. 2,000 m.</li> <li>• Ambient temperature: 5°C to 40°C. (41°F to 104°F)</li> <li>• Maximum relative humidity 80% for temperatures up to 31°C (88°F), decreasing linearly through 70% (at 34°C), 60% (at 37°C) to 50% (at 40°C).</li> <li>• Supply voltage fluctuation: <math>\pm</math>10%.</li> <li>• Pollution degree: 2 (IEC60664)</li> <li>• Installation category (overvoltage category): II (IEC60664)</li> </ul>		

Under certain conditions, performance of the equipment may be adversely affected by factors other than defects. If a problem occurs, please review the following list and take remedial action as needed. If you cannot solve the problem after checking the entire list, contact Olympus.

Problem	Cause	SZX2-			Remedy	Page
		ILLK	ILLB	ILLD		
<b>1. Optical System</b>						
a. Illumination is too bright or too dark.	The light intensity control knob is set improperly.	○	○	○	Adjust the knob properly.	6
	Optimum ND filter(s) are not selected.	—	○	—	Select optimum ND filter(s).	8
	The oblique illumination is set.	○	○	—	Correct it properly.	9
b. Illumination irregularities are noticeable.	The lamp bulb is installed improperly.	○	○	○	Install it properly.	20
	The contrast selector lever and/or other adjustment knobs are set improperly.	○	○	○	Set them properly.	9;10
	The oblique illumination adjustment knob is set improperly.	○	○	—	Set it properly.	9
	A filter insertion knob is stopped halfway.	—	○	—	Push or pull it all the way.	8
	The window lens, waterproof glass and/or stage glass are dirty.	○	○	○	Clean them.	3
	The contrast selector lever or brightfield/ darkfield selector lever is stopped halfway.	—	○	○	Set them all the way to the stop position.	10
	The light axis is aligned improperly.	○	○	○	Align it properly.	6
c. Field of view is dusty or dirty.	The window lens, waterproof glass and/or stage glass are dirty.	○	○	○	Clean them.	3
	The eyepieces are dirty or dusty.	○	○	○	Clean them.	3

Problem	Cause	SZX2-			Remedy	Page
		ILLK	ILLB	ILLD		
d. The image is glaring. (The resolution is poor.)	The illumination does not match the specimen.	○	○	○	Engage a frosted filter in the light path to obtain flat illumination.	8
	The oblique illumination adjustment knob is set improperly.	○	○	—	Set it properly.	9
e. Color reproduction in color photomicrography is poor.	The light intensity control knob is not set to the maximum position.	○	○	○	Set the knob to the maximum position.	10
	Too low a color temperature makes the picture reddish.	○	○	○	Set the light intensity control knob to the maximum position.	10
	Too high a color temperature makes the picture bluish.	○	○	○	Reduce the light intensity control knob slightly below the maximum position.	10
	The built-in LBD or the 45LBD-IF filter is not engaged.	○	○	○	Engage the filter in the light path.	8
	The colors do not match your needs.	○	○	○	Correct color reproduction using a commercially available CC filter, etc.	—
<b>2. Electrical System</b>						
a. The lamp bulb does not light.	The bulb is not installed.	○	○	○	Install the specified bulb.	20
	The bulb is blown.	○	○	○	Replace the bulb.	20
b. The lamp bulb blows easily.	The supply voltage is too high.	○	○	○	Reduce it using a slidac, etc.	—
	The bulb in use is not the specified bulb.	○	○	○	Use the specified bulb.	20
c. The lamp bulb turns on and off repeatedly.	The bulb is half blown.	○	○	○	Replace the bulb with new one.	20
	The lamp socket or power cord is connected improperly.	○	○	○	Connect them securely.	20,22

○: Applicable. : Not applicable.

# 5 OPERATION OF OTHER MODULES

## 5-1 Analyzer SZX2-AN and Polarizer SZX-PO

©Combining the SZX2-AN analyzer and SZX-PO polarizer with the transmitted light illuminator stand enables simplified transmitted light polarized observation. This makes it possible to identify the transmitted light polarization characteristics (birefringent and polarizing characteristics) easily.

### 1 External View

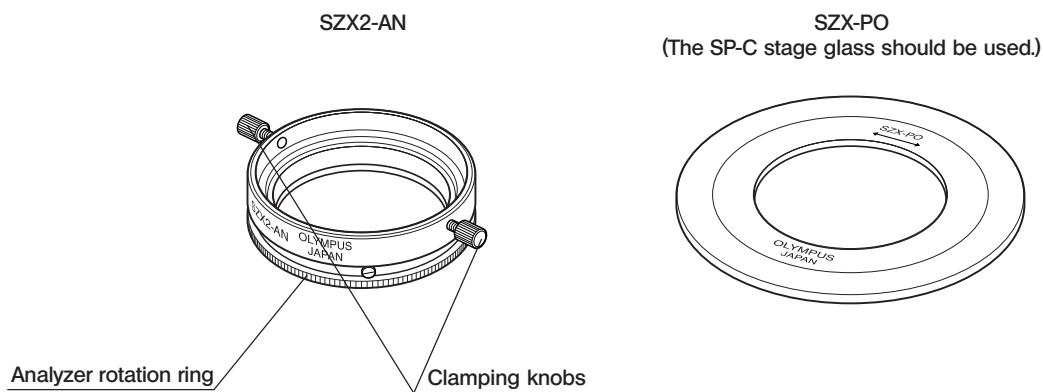

### 2 Handling Precautions

- Operating ambient temperatures: 5°C to 40°C (41°F to 104°F)
- The frosted filter cannot be used.

### 3 Assembly

(Figs. 11 & 12)

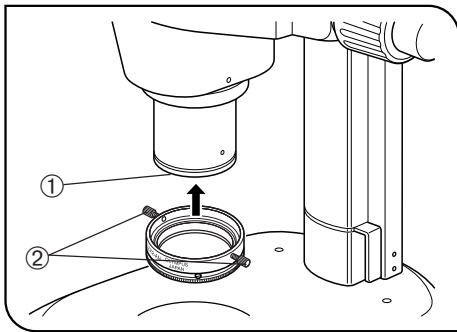

Fig. 11

#### 1. Mounting the analyzer

- Fit the analyzer into the objective tip ① so that model name indication “SZX2-AN” comes on the front, and tighten the two clamping knobs ② firmly. (Fig. 11)

Make sure that the clamping knobs are positioned on both sides.

- ★ Fit carefully so that the analyzer is not tilted with respect to the objective front lens.

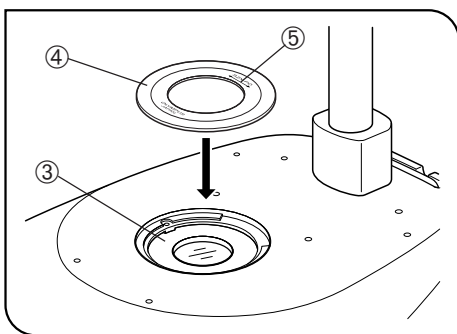

Fig. 12

#### 2. Mounting the polarizer

- Remove the stage glass by pushing a point on the pillar side of its top surface (see page 21).

- Place the polarizer ④ in the polarizer mounting hole ③ so that the arrow ⑤ comes on the top.

- ★ Place the polarizer so that the arrow ⑤ points the lateral direction (i.e. the direction of the polarizer oscillation) as shown in Fig. 12.

- Place the stage glass in the original position.

### 4 Operation

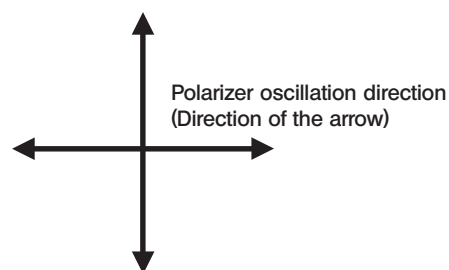

Analyzer oscillation direction  
(Position of the white dot)

Cross Nicol condition

#### Observing a birefringent substance

1. Rotate the analyzer rotation ring to make the field of view darkest (cross Nicol position). (Do not place the specimen during this adjustment.)
  2. Place the specimen on the stage glass and rotate the specimen (or stage glass) to perform polarized light observation.
- ⊙ When the specimen contains a birefringent substance, the corresponding part is darkened and brightened during the rotation.
  - ⊙ The contrast can sometimes be enhanced by stopping down the aperture iris diaphragm of the microscope.

#### Identifying the polarizing characteristic of a substance

1. Remove the polarizer
  2. Rotate the analyzer or specimen to perform polarized light observation.
- ⊙ When the specimen contains a polarizing substance, the corresponding part is darkened and brightened during the rotation.

## 5-2 Jewel Observation Clip SZH-CLJ

©The SZH-CLJ can be used mainly with the SZX2-ILLD transmitted light brightfield/darkfield illumination stand.  
The SZH-CLJ is used to hold the inspected object such as jewel during the brightfield and darkfield observations.

### Operation

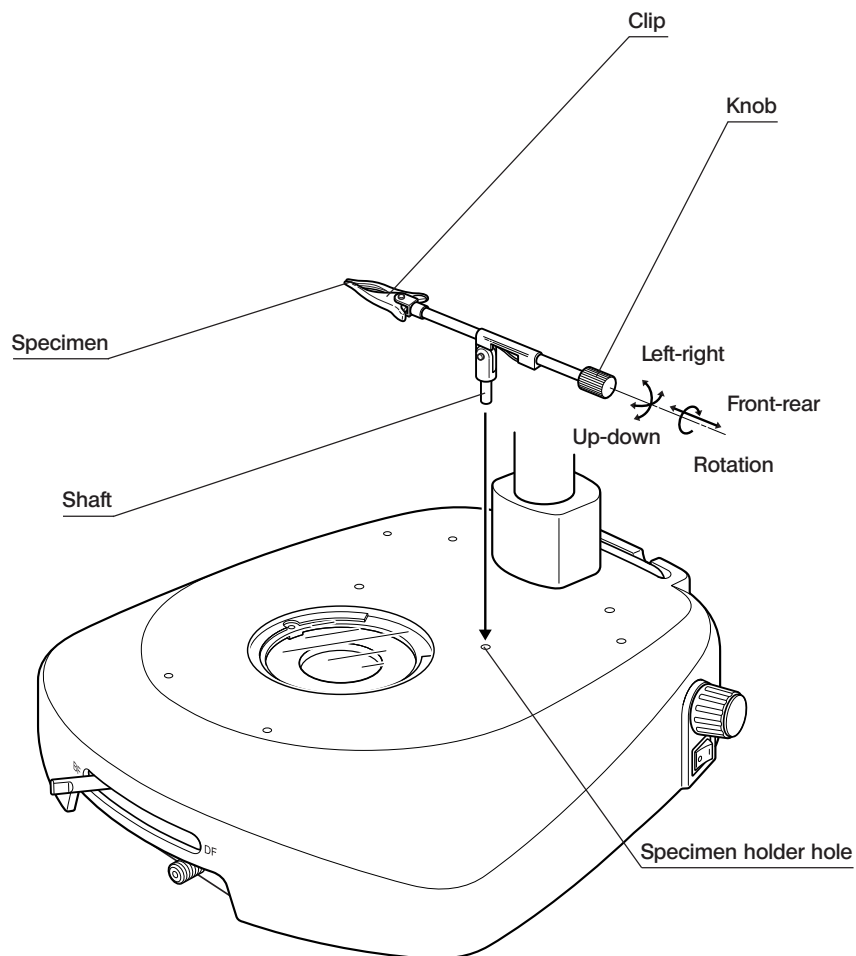

Pinch the knob with your fingertips and move the specimen in the front-rear, left-right and up-down directions to engage it in the observation light path.

## 5-3 Large Clear Center Plate SZX-CL

©The SZX-CL prevents contamination, improves heat protection and facilitates disinfection when handling a living specimen. When using colored cellophane sheets or similar tools for background treatment (illumination) for macro photomicrography, they can be placed below the SZX-CL.

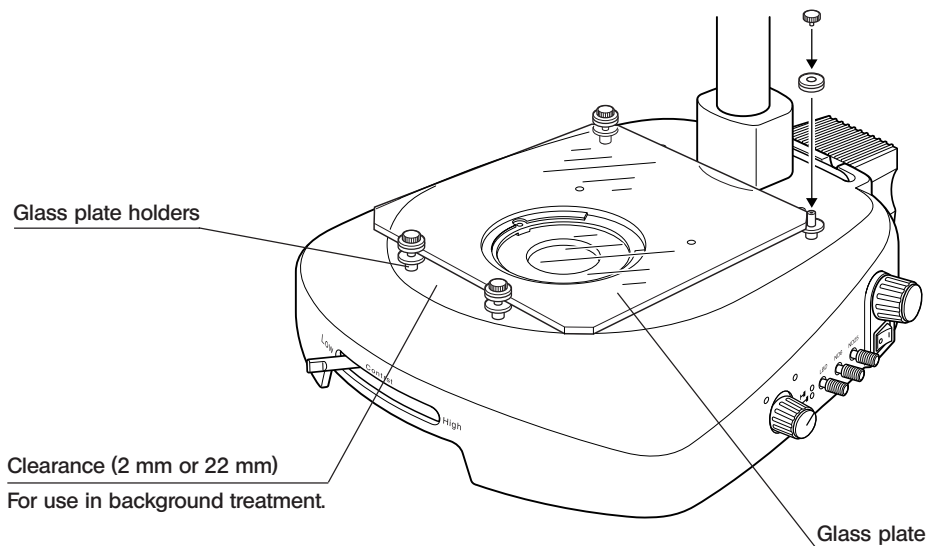

### 1 Assembly

(Fig. 13)

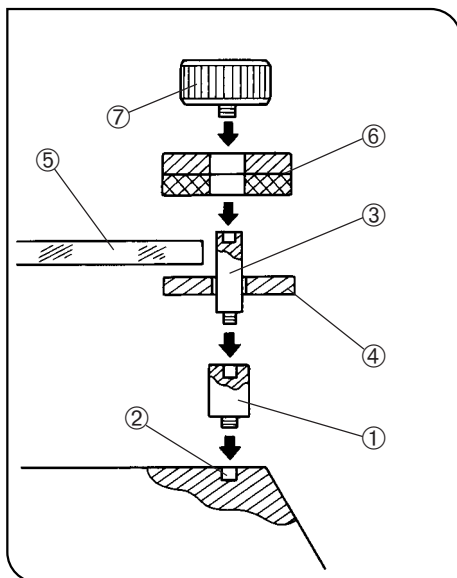

Fig. 13

#### Setting the clearance to 22 mm

1. Using a coin, etc., screw in the four holders ① into the four screw holes ② on the top of the stage.
2. Using the coin, etc., screw in the four glass holder shafts ③ into the holders ①.
3. Fit the four resin (polyacetal) washers ④ into the glass holder shafts ③.
4. Place the glass plate ⑤ so the two rear chamfered corners and the front edge are held by the four resin washers ④.  
(Make sure that the four washers securely hold the glass plate.)
5. Fit the four resin washers ⑥ into the glass holder shafts ③ so that the rubber surfaces face downward.
6. Insert the four clamping knobs ⑦ and tighten firmly.

★ The clamping knobs should be re-tightened at times because their loosening causes the glass plate to drop down.

#### Setting the clearance to 2 mm

Do not use the holders ① but insert the glass holder shafts ③ directly into the stage.

**5-4 Transmitted Light Guide Adapter SZX-TLGAD and Flexible Light Guide LG-SF**

©The SZX-TLGAD and LG-SF allows the light source to be installed at a distance from the transmitted light illuminator stand. As this installation prevents the stand temperature from rising, it is effective when strict temperature control of the specimen is required.

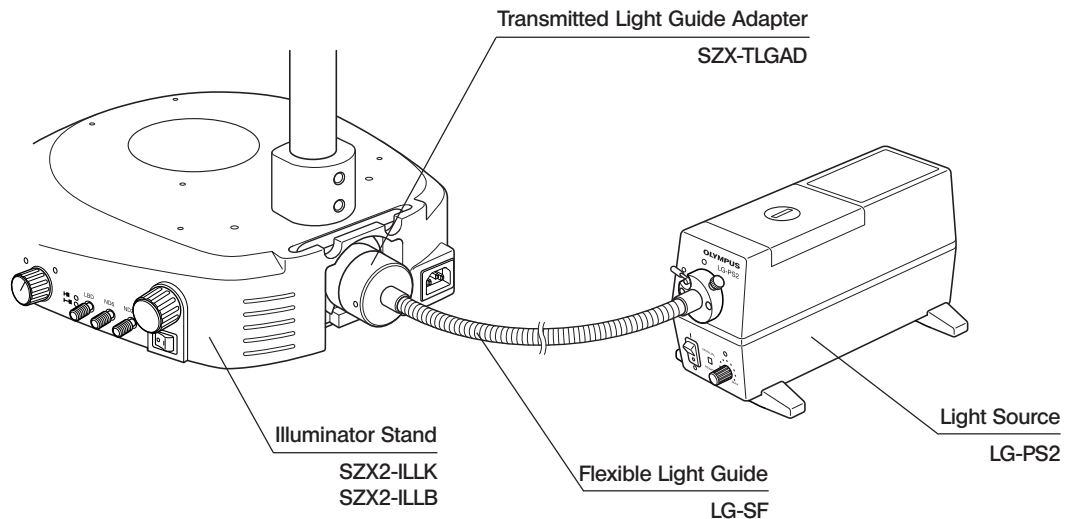

**1 Assembly and Operation**

(Figs. 14 & 15)

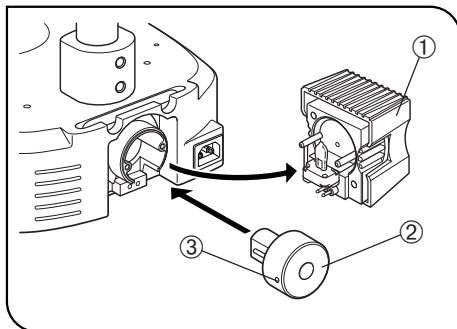

Fig. 14

1. Remove the lamp socket ① from the illumination stand by gently pulling the socket toward the rear of the stand. (Fig. 14)
2. Hold the transmitted light guide adapter ② so that the clamping screw ③ comes on the side, align the guide pin with the guide hole, and fit the adapter all the way into the position where the lamp socket has been, until it is stopped. (Fig. 14)

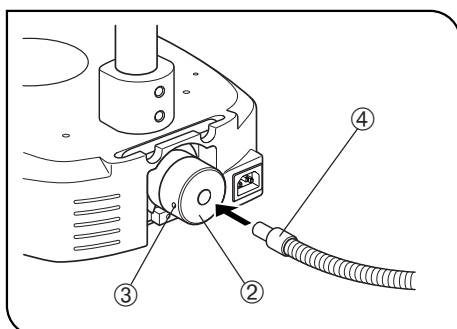

Fig. 15

3. Gently insert the output end ④ of the flexible light guide all the way into the light guide adapter ②, and tighten the clamping screw ③ using the Allen screwdriver provided with the microscope body.
4. Connect the incident end of the light guide to the LG-PS2 light source as described in the instruction manual for the light guide illumination system.
5. For the operating method, refer to the instruction manual for the LG-PS2 light source.

©With this installation, the illumination tends to be darker than that when the U-LS30-5 lamp socket is used due to the loss of light in the light guide, etc.

# 6 ASSEMBLY

## 6-1 Assembly Diagram

The diagram below shows how to assemble the various modules. The numbers indicate the order of assembly.

★ When assembling the equipment, make sure that all parts are free of dust and dirt, and avoid scratching any part.

★ For safety, set the main switch to "O" (OFF) before assembly.

© The halogen bulb in the SZX2-ILLD can be replaced by pulling out the lamp mount insertion lever.

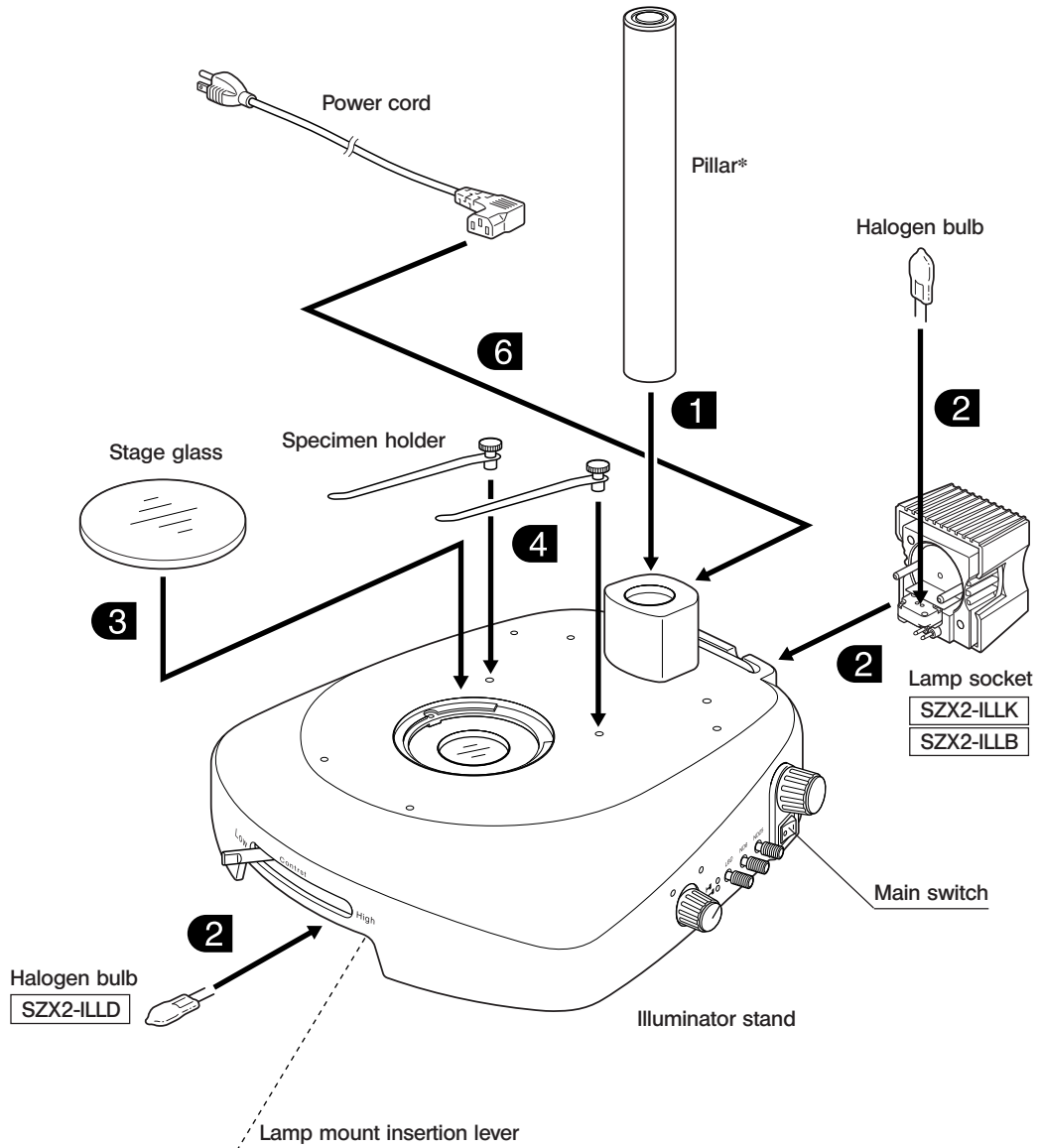

Required tools	
Allen wrench	
(Provided with the illuminator stand)	

\* The top end of the pillar has a hole for storing the Allen screwdriver  provided with the zoom microscope body.

## 6-2 Detailed Assembly Procedure

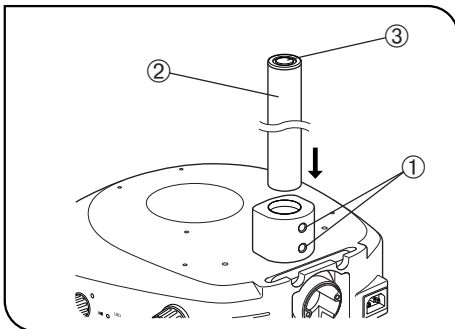

Fig. 16

### 1 Installing the Pillar (Fig. 16)

1. Using the Allen wrench provided with the illuminator stand, loosen the two clamping screws ① on the pillar support sleeve completely.
2. Hold the pillar ② so that the Allen screwdriver storage hole ③ comes at the top, and insert the pillar into the pillar support sleeve until it reaches the bottom.
3. Tighten the two clamping screws ① securely using the Allan wrench.

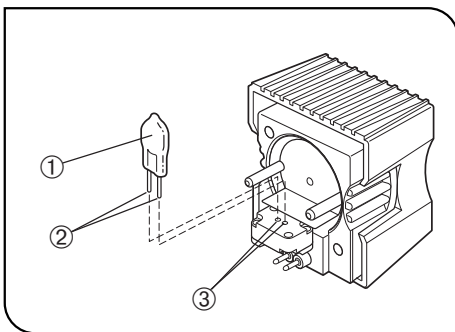

Fig. 17

### 2 Mounting the Lamp Bulb (Figs. 17-19)

Applicable bulb:  
Halogen bulb:6V30WHAL (Philips 5761).

- ★ Do not touch the bulb directly with your hand. If fingerprints are attached, wipe them completely using a soft cloth in order to prevent shortening of the service life or bursting of the bulb.

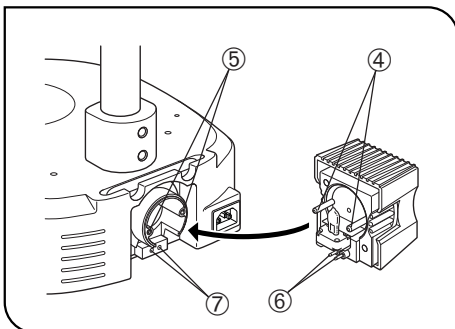
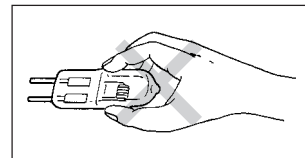

Fig. 18

#### SZX2-ILLK/ILLB

1. Holding the bulb section ① with a piece of gauze, etc., insert the pins ② all the way straight into the pin holes ③ on the lamp socket. (Fig. 17)
2. Aligning the guide pins ④ with the guide holes ⑤ on the rear of the illuminator stand, push the plugs ⑥ into the socket ⑦.

#### SZX2-ILLD

1. Rotate the lamp mount insertion lever ⑧ in the direction of the arrow so that the lamp mount ⑨ comes on the front.
2. Holding the bulb section ⑩ with a piece of gauze, etc., insert the pins all the way straight into the pin holes on the lamp mount ⑨.
3. Hold the lamp mount insertion lever ⑧ and gently return it to the original position.

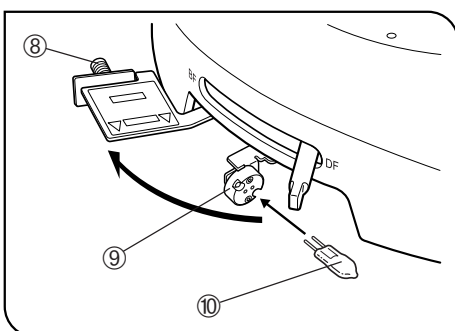

Fig. 19

#### ▲ Caution for bulb replacement in the middle of observation

The bulb, lamp socket and areas near these will be extremely hot during and right after use.

After setting the main switch to "O" (OFF) and unplugging the power cord from the wall outlet, allow the old bulb and lamp socket to cool before replacing the bulb with a new one of the designated type.

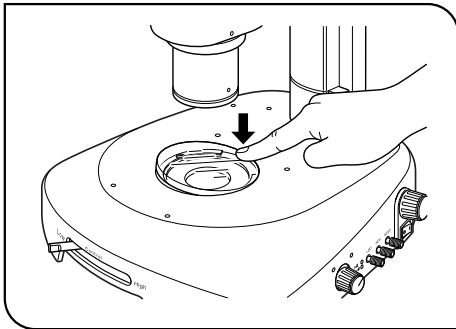

Fig. 20

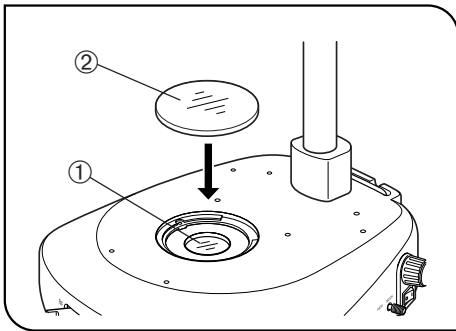

Fig. 21

### 3 Attaching the Stage Glass (Figs. 20 & 21)

⊙ To remove the stage glass, push down the pillar-side end of the stage glass with a fingertip. This lifts the front-end side of the stage glass so that it can be removed by pinching this end. (Fig. 20)

★ Ensure that the window lens or waterproof glass ① is free of dust or dirt.

If it is dusty or dirty, clean it.

1. Remove dust and dirt from the stage glass ② and gently drop it into the hole on the stage surface. (Fig. 21)

★ Special care is required against dust and dirt in darkfield and/or low-magnification observations because they are particularly noticeable in these observations.

### 4 Attaching the Specimen Holder

⊙ Use the specimen holder for fixing the specimen for observation.

1. Insert the specimen holder shafts into the two mounting holes on the stage surface.

⊙ If a specimen holder mounting shaft ① is loose, widen it slightly using the tip of a flat-blade screwdriver ②, etc.

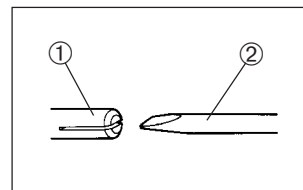

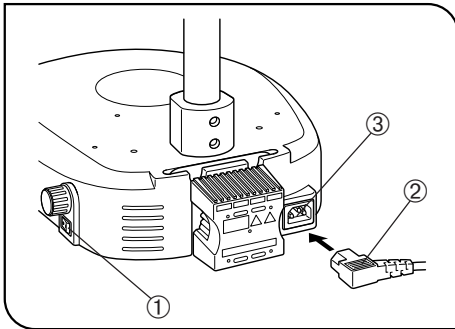

Fig. 22

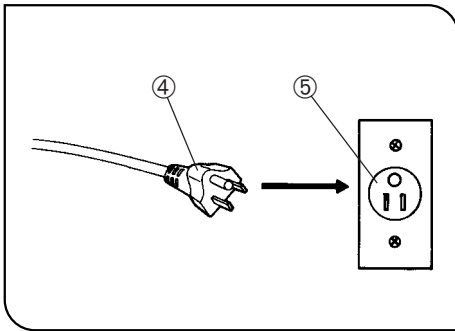

Fig. 23

## 5 Connecting the Power Cord (Figs. 22 & 23)

- ▲ Cables and cords are vulnerable to bend or twist. Do not apply excessive force to them.
- ▲ Make sure that the main switch ① is set to “○” (OFF) before connecting the power cord.
- ▲ Always use the power cord provided by Olympus. If no power cord is provided, please select the power cord by referring to the section “PROPER SELECTION OF THE POWER SUPPLY CORD” at the end of this instruction manual. If the proper power cord is not used, Olympus can no longer warrant the electrical safety performance of the equipment.

1. Connect the power cord plug ② to the AC receptacle ③. (Fig. 22)

- ▲ Connect the provided power cord correctly and ensure that the grounding terminal of the power supply and that of the 3-conductor wall outlet are properly connected. If the equipment is not grounded, Olympus can no longer warrant the electrical safety performance of the equipment.

2. Connect the power cord plug ④ to a 3-conductor power outlet ⑤.

(Fig. 23)

- ▲ Route the power cord away from the lamp socket. If it comes in contact with the hot area near the lamp socket, its coverings may melt and cause an electrical shock hazard.

## 6 Attaching the Antiglare Plate

(Figs. 24 & 25)

© The antiglare plate attaching methods are variable between model SZX2-CCV (for use with the SZX2 series) and SZX-CCV (for use with the SZX series).

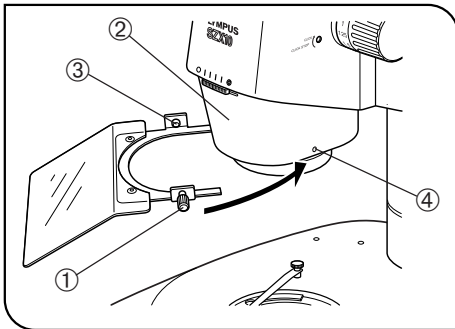

Fig. 24

### SZX2-CCV

1. Loosen the antiglare plate clamping knob ① and insert the pin ③ on the antiglare plate into the positioning hole on the left side of the zoom microscope body ②.
2. Rotate the antiglare plate in the direction of the arrow so that it comes in close contact with the zoom microscope body.
3. Insert the clamping knob ① into the positioning hole ④ on the right side, and tighten the knob to fix the antiglare plate.

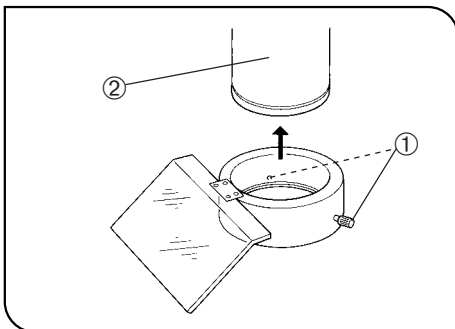

Fig. 25

### SZX-CCV

1. Loosen the two antiglare plate clamping knobs ① and fit the antiglare plate into the tip of the objective ②.
2. Tighten the two clamping knobs ① to fix the antiglare plate.

## ■ PROPER SELECTION OF THE POWER SUPPLY CORD

If no power supply cord is provided, please select the proper power supply cord for the equipment by referring to “ Specifications ” and “ Certified Cord ” below:



















**CAUTION:** In case you use a non-approved power supply cord for Olympus products, Olympus can no longer warrant the electrical safety of the equipment.

### Specifications

Voltage Rating	125V AC (for 100-120V AC area) or, 250V AC (for 220-240V AC area)
Current Rating	6A minimum
Temperature Rating	60°C minimum
Length	3.05 m maximum
Fittings Configuration	Grounding type attachment plug cap. Opposite terminates in molded-on IEC configuration appliance coupling.

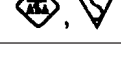
**Table 1 Certified Cord**

A power supply cord should be certified by one of the agencies listed in Table 1 , or comprised of cordage marked with an agency marking per Table 1 or marked per Table 2. The fittings are to be marked with at least one of agencies listed in Table 1. In case you are unable to buy locally in your country the power supply cord which is approved by one of the agencies mentioned in Table 1, please use replacements approved by any other equivalent and authorized agencies in your country.

Country	Agency	Certification Mark	Country	Agency	Certification Mark
Argentina	IRAM		Italy	IMQ	
Australia	SAA		Japan	JET, JQA, TÜV, UL-APEX / MITI	
Austria	ÖVE		Netherlands	KEMA	
Belgium	CEBEC		Norway	NEMKO	
Canada	CSA		Spain	AEE	
Denmark	DEMKO		Sweden	SEMKO	
Finland	FEI		Switzerland	SEV	
France	UTE		United Kingdom	ASTA BSI	
Germany	VDE		U.S.A.	UL	
Ireland	NSAI				

**Table 2 HAR Flexible Cord**

APPROVAL ORGANIZATIONS AND CORDAGE HARMONIZATION MARKING METHODS

Approval Organization	Printed or Embossed Harmonization Marking (May be located on jacket or insulation of internal wiring)		Alternative Marking Utilizing Black-Red-Yellow Thread (Length of color section in mm)		
			Black	Red	Yellow
Comite Electrotechnique Belge (CEBEC)	CEBEC	⟨HAR⟩	10	30	10
Verband Deutscher Elektrotechniker (VDE) e.V. Prüfstelle	⟨VDE⟩	⟨HAR⟩	30	10	10
Union Technique de l'Electricite' (UTE)	USE	⟨HAR⟩	30	10	30
Instituto Italiano del Marchio di Qualita' (IMQ)	IEMMEQU	⟨HAR⟩	10	30	50
British Approvals Service for Electric Cables (BASEC)	BASEC	⟨HAR⟩	10	10	30
N.V. KEMA	KEMA-KEUR	⟨HAR⟩	10	30	30
SEMKO AB Svenska Elektriska Materielkontrollanstalter	SEMKO	⟨HAR⟩	10	10	50
Österreichischer Verband für Elektrotechnik (ÖVE)	⟨ÖVE⟩	⟨HAR⟩	30	10	50
Danmarks Elektriske Materialkontroll (DEMKO)	⟨DEMKO⟩	⟨HAR⟩	30	10	30
National Standards Authority of Ireland (NSAI)	⟨NSAI⟩	⟨HAR⟩	30	30	50
Norges Elektriske Materielkontroll (NEMKO)	NEMKO	⟨HAR⟩	10	10	70
Asociacion Electrotecnica Y Electronica Espanola (AEE)	⟨UNED⟩	⟨HAR⟩	30	10	70
Hellenic Organization for Standardization (ELOT)	ELOT	⟨HAR⟩	30	30	70
Instituto Portages da Qualidade (IPQ)	np	⟨HAR⟩	10	10	90
Schweizerischer Elektro Technischer Verein (SEV)	SEV	⟨HAR⟩	10	30	90
Elektriska Inspektoratet	SETI	⟨HAR⟩	10	30	90

Underwriters Laboratories Inc. (UL)  
Canadian Standards Association (CSA)

SV, SVT, SJ or SJT, 3 X 18AWG  
SV, SVT, SJ or SJT, 3 X 18AWG

# 7 LAMP SOCKET INSPECTION SHEET

- Study the instruction manual for the lamp socket before inspection.
- For safe use of the lamp socket, we recommend performing the following inspection periodically (every time you replace the lamp bulb and at least every 6 months).
- The table below identified the check items to be observed. Put (X) if not applicable or (√) if applicable.
- If there is any (X) mark noted, immediately stop use of the product, and consult Olympus for detailed inspections or replace the lamp socket.
- If you detect an abnormality other than that listed below or with other Olympus product, also stop the use of the product and contact Olympus for detailed inspections.
- Note that the service, replacement and detailed inspections are charged after expiration of the warranty period.

If you have any questions, please contact Olympus.

Check items	Check results (Date)			
	/	/	/	/
1. More than 8 years have passed since original purchase or the total power ON time exceeds 20,000 hours.				
2. Lamp does not light sometimes even though the main switch is set to on.				
3. Illumination flickers when you move the lamp socket.				
4. Scorching or burning odor is produced during use.				
5. Illumination still flickers after replacement with a new lamp bulb.				
6. Deformation, backlash, or looseness, etc. when you assemble the lamp socket.				
7. Extreme discoloration of the lamp socket connection terminal or lamp socket lamp bulb mount.				
8. Discoloration, deformation or cracking of the lamp socket.				
9. Melting, crack, deformation or solidification of the wiring parts.				
10. Increased frequency of servicing compared to similar devices put into use at the same time as the lamp socket.				

\* When the Check Result columns become insufficient, copy this sheet.

# *MEMO*



# OLYMPUS®

---



**OLYMPUS CORPORATION**

Shinjuku Monolith, 3-1, Nishi Shinjuku 2-chome, Shinjuku-ku, Tokyo, Japan



**OLYMPUS LIFE SCIENCE EUROPA GMBH**

Postfach 10 49 08, 20034, Hamburg, Germany

**OLYMPUS AMERICA INC.**

3500 Corporate Parkway, P.O. Box 610, Center Valley, PA 18034-0610, U.S.A.

**OLYMPUS SURGICAL & INDUSTRIAL AMERICA INC.**

One Corporate Drive, Orangeburg, NY 10962, U.S.A.

**OLYMPUS SINGAPORE PTE LTD.**

491B River Valley Road, #12-01/04 Valley Point Office Tower, Singapore 248373

**OLYMPUS AUSTRALIA PTY. LTD.**

31 Gilby Road, Mount Waverley, VIC., 3149, Australia

**OLYMPUS LATIN AMERICA, INC.**

5301 Blue Lagoon Drive, Suite 290 Miami, FL 33126, U.S.A.

