

Instructions

BX3-MDO18R

Discussion attachments

For 10 persons, 18 persons and 26 persons

To ensure safety, obtain optimum performance and to familiarize yourself fully with the use of this product, we recommend that you study this manual thoroughly before operating this product, and always keep this manual reachable when operating this product.

For details of products included in the configuration of this system, see page 7 of this instruction manual.

Optical Microscope Accessory

AX 8958

This product is applied with the requirements of standard IEC/EN61326-1 concerning electromagnetic compatibility.

- Immunity Applied to industrial and basic environment requirements.



In accordance with European Directive on Waste Electrical and Electronic Equipment, this symbol indicates that the product must not be disposed of as unsorted municipal waste, but should be collected separately.

Refer to your local distributor in EU for return and/or collection systems available in your country.

NOTE: This product has been tested and found to comply with the limits for a Class A digital device, pursuant to Part 15 of the FCC Rules. These limits are designed to provide reasonable protection against harmful interference when the product is operated in a commercial environment. This product generates, uses, and can radiate radio frequency energy and, if not installed and used in accordance with the instruction manual, may cause harmful interference to radio communications.

Operation of this product in a residential area is likely to cause harmful interference in which case the user will be required to correct the interference at his own expense.

FCC WARNING: Changes or modifications not expressly approved by the party responsible for compliance could void the user's authority to operate the product.

Contents

Introduction	1
Safety precautions	2
1 Configuration of the discussion system and orientation of observed images ..	5
2 Nomenclature of units and functions	6
3 Operation	8
3-1 Using the stray light prevention cover.....	8
3-2 Diopter adjustment.....	8
1 Diopter adjustment of main observer.....	8
2 Diopter adjustment of assistant observer.....	9
3-3 Pointer operation	10
1 Adjusting the pointer brightness.....	10
2 Selecting the pointer color	10
3 Moving the pointer.....	10
3-4 Notes for image acquisition.....	11
4 Specifications	12
5 Assembly	14
1 Attaching BX3-MDO18R.....	14
2 Attaching U-MDO10B3	18
3 Attaching U-MDOSV.....	19
4 Attaching BX3-MDOE	21
5 Attaching U-MDOSV (Extension).....	22
6 Extending the system for 26 persons.....	24
7 Attaching the observation tube	25
8 Attaching the eyepieces	28
9 Adjusting the stand height.....	29
10 Connecting the AC adapter.....	31
11 Attaching the cord stopper.....	32

■ Proper selection of the power supply cord 33

Introduction

This system is a discussion attachment used together with the BX series microscope. Eyepieces, objectives or condensers, etc. used together with this system should be applied to UIS2 (or UIS) optical system series.

Instruction manual

This document is an instruction manual for discussion attachment. Read it together with the instruction manual for microscope.

Safety precautions

If the product is used in a manner not specified by this manual, the safety of the user may be imperiled. In addition, the product may also be damaged. Always use the product according to this instruction manual.

The following symbols are used in this instruction manual.

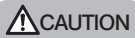
 **CAUTION** : Indicates a potentially hazardous situation which, if not avoided, may result in minor or moderate injury.

 **NOTE** : Indicates a potentially hazardous situation which, if not avoided, may result in damage to the product or other property and/or may cause problems.

 **TIP** : Indicates the useful knowledge or information for use.

CAUTION - Installation of the product -

Install the product on a sturdy and level desk.

With this system, the product is installed on the multiple desks which are arranged side by side. All desks must be sturdy and level. Also, take proper measures to fix the desks to avoid them from moving.

CAUTION - Electric safety -

Always use the power cord provided by us.

If the proper AC adapter and the power cord are not used, the electric safety and the EMC (Electro-Magnetic Compatibility) performance of the product can not be assured. If no power cord is provided, please select the proper power cord by referring to the section "Proper selection of the power cord" at the end of this instruction manual.

Always connect the ground terminal.

Connect the ground terminal of the power cord and that of the power outlet. If the product is not grounded, our intended electric safety and EMC performance of the product cannot be assured.

Do not use the product in close proximity to the sources of strong electromagnetic radiation.

Proper operation may be interfered. The electromagnetic environment should be evaluated prior to operation of the product.

Disconnect the power cord in case of emergency.

In case of emergency, disconnect the power cord from the power cord connector on the product or from the power outlet. Install the product at a location where you can reach the power cord connector or the power outlet at hand to disconnect the power cord quickly.

Do not connect or disconnect the power cord, cables and units while the power is on.

CAUTION - Prevention of electric shock -

Keep the power cord and cables well away from the lamp housing.

If the power cord and cables contact a hot area of the lamp housing, they could melt and cause electric shock.



Do not touch the product with wet hands.

In particular, if you touch the main switch of the power unit or the power cord with wet hands, electric shock, ignition or failure of the product may be caused.

CAUTION - Safety symbols -

The following symbols are placed on the product.

Study the meaning of the symbols and always use the product in the safest possible manner.

Symbols	Meaning
	Supply DC current (from the provided AC adapter).
	Indicates an input jack.
	Indicates a pointer.

Handling precautions

NOTE • This product is a precision instrument. Handle it with care and avoid subjecting it to a sudden or severe impact.

• Never disassemble any part of the product. Otherwise, failure could be caused.

• Do not use the product in areas where it may be subjected to direct sunlight, high temperature and/or humidity, dust or vibrations.

For the conditions of operating environments, see "4 Specifications" (page 12).

1. If this system is combined with a super widefield eyepiece, the pointer cannot be moved around the entire range of the field of view. Also, a ghost of the pointer may be observed.
2. If the eyepiece is equipped with a micrometer, a ghost of the pointer may be observed.
3. To prevent the stray light:
 - Cover the eyepieces which are not used by the assistant observers with the provided stray light prevention covers (page 8, page 11).
 - Make sure to attach caps to the unused tube mounts and observation side viewer mounts.
4. To ensure safety, disconnect the power plug of the AC adapter from the power outlet after use.
5. Using the provided cord stopper (page 32), place the AC adapter cord at the position where it does not come in the way of microscope operation and take care not to bring the cord in contact with the lamp housing.
6. If the reflected light illuminator is combined, this discussion observation tube cannot be combined.

Maintenance and storage

1. Do not leave stains or fingerprints on the lenses and filters. If they get dirty, blow away dust with a commercially available blower and gently wipe the lens or filter with a piece of cleaning paper (or clean gauze).
Only when cleaning fingerprints and oil stains, slightly moisten a piece of cleaning paper with commercially available absolute alcohol and wipe them off with it.

⚠ CAUTION

Since the absolute alcohol is highly flammable, it must be handled carefully. Be sure to keep it away from open flames or potential sources of electrical sparks. For example, the electrical equipment that is switched on and off may cause the ignition of a fire. Also, always use absolute alcohol only in a well-ventilated room.

2. Wipe the portions other than the lens with a dry soft cloth. If the dirt cannot be removed by dry-wiping, moisten a soft cloth with diluted neutral detergent and wipe the dirty surface with it.

NOTE Do not use the organic solvents because they may deteriorate the coated surface or plastic parts.

3. After using this product, set the main switch to "○" (OFF), wait until the lamp housing is cooled down sufficiently, and keep it covered with a dust cover during storage.
4. Before disposing of this product, be sure to follow the regulations and rules of your local government.

1

Configuration of the discussion system and orientation of observed images

The following illustration shows the top view of the discussion system.

↓ expresses the orientation of the line of sight of the observer.

⊙(ABC) expresses the orientation of the image observed through each eyepieces.

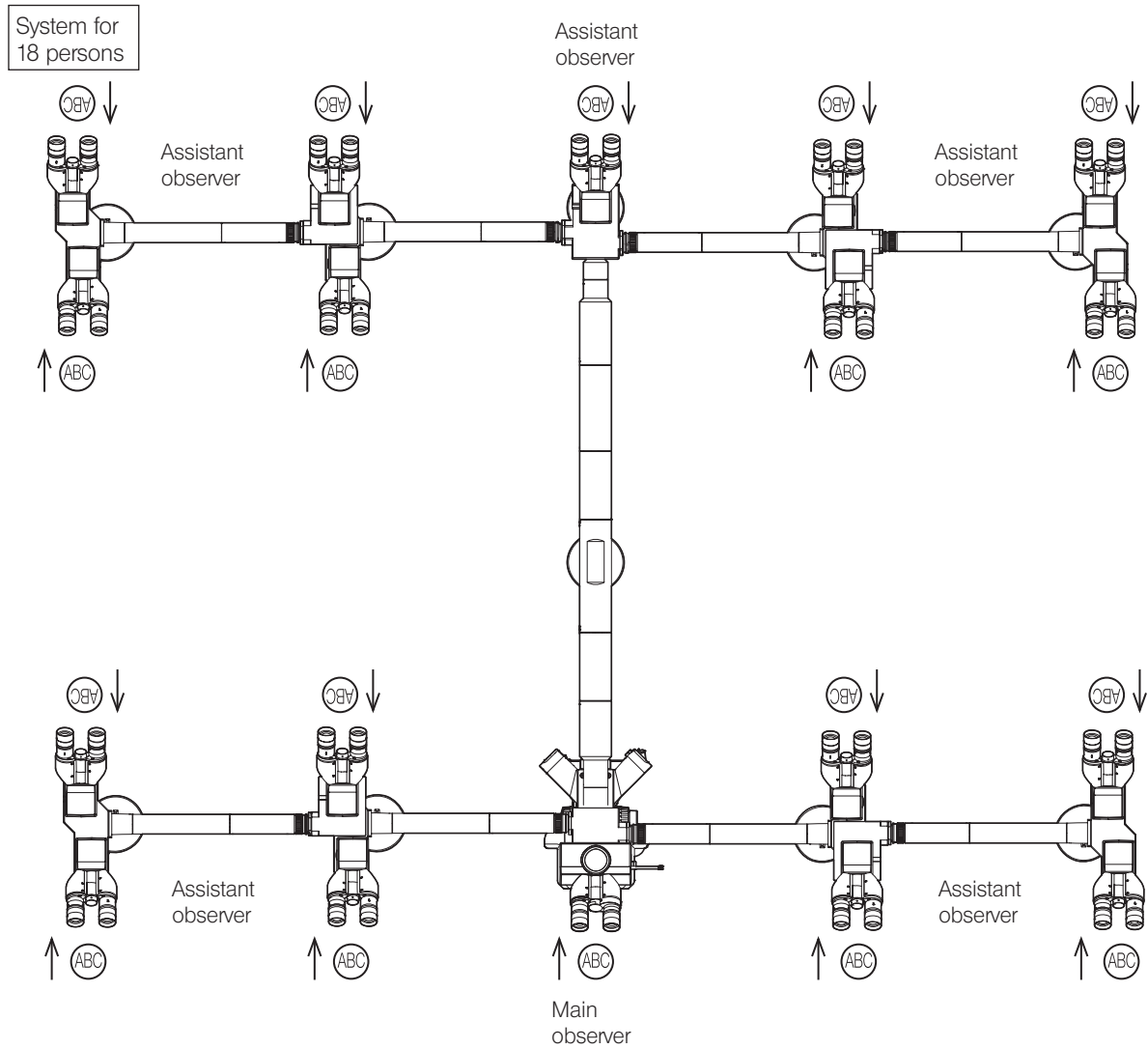

TIP



If the observation tubes are not attached in the orientation as shown in the above illustration, the orientation of the image rotates.

2 Nomenclature of units and functions

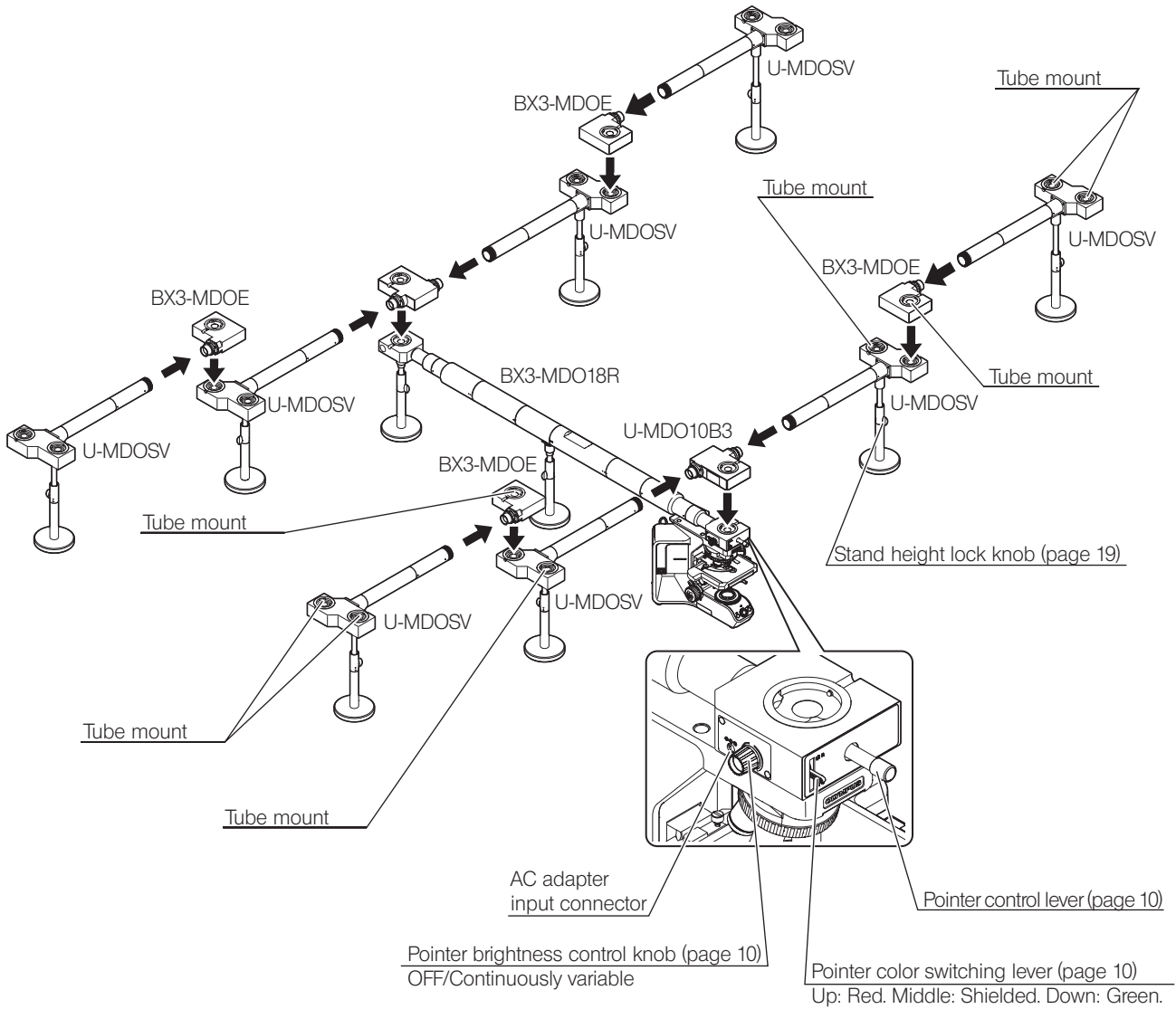
System for 18 persons

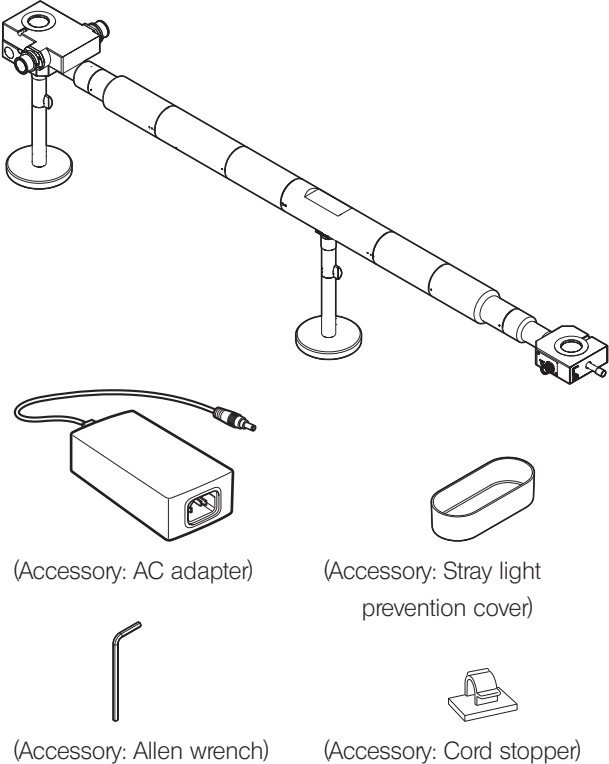
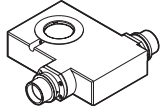
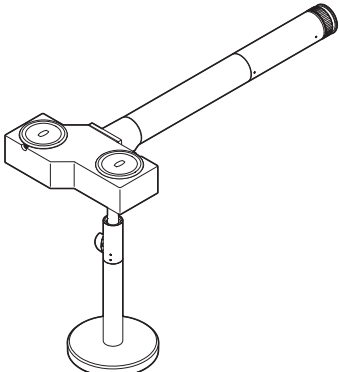

List of configuration units

	Product model name	Name in English
 <p>(Accessory: AC adapter)</p> <p>(Accessory: Stray light prevention cover)</p> <p>(Accessory: Allen wrench)</p> <p>(Accessory: Cord stopper)</p>	<p>BX3-MDO18R</p>	<p>Multi observation body for 18 persons</p>
	<p>U-MDO10B3</p>	<p>Multi observation body for 10 persons</p>
	<p>U-MDOSV</p>	<p>Multi observation side viewer</p>
 <p>(Accessory: Stand raising parts)</p>	<p>BX3-MDOE</p>	<p>Multi observation extension</p>

3 Operation

3-1 Using the stray light prevention cover

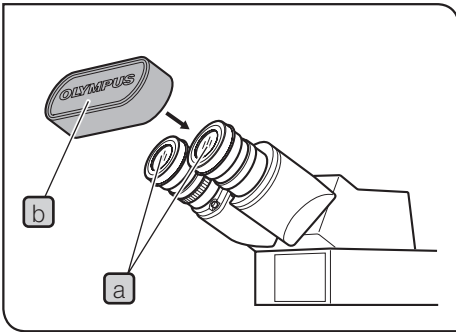

- 1 Cover the eyepieces **a** which are not used by the assistant observers with the provided stray light prevention covers **b**.

3-2 Diopter adjustment

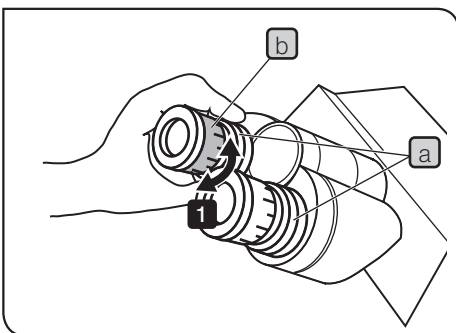

1 Diopter adjustment of main observer

When the eyepiece is equipped with the eyepiece micrometer

- 1 While looking through the eyepiece equipped with the eyepiece micrometer, rotate the diopter adjustment ring **b** to adjust the focusing so that the scales and lines of the eyepiece micrometer can be viewed clearly. When rotating the diopter adjustment ring **b**, hold the bottom area **a** of the eyepiece.
- 2 Place the specimen.
- 3 Engage the 10X objective in the light path. While looking through the eyepiece equipped with the eyepiece micrometer, rotate the coarse/fine focusing knobs to bring the specimen into focus.
- 4 Rotate the diopter adjustment ring **b** of the eyepiece which is not equipped with the eyepiece micrometer to bring the specimen into focus.

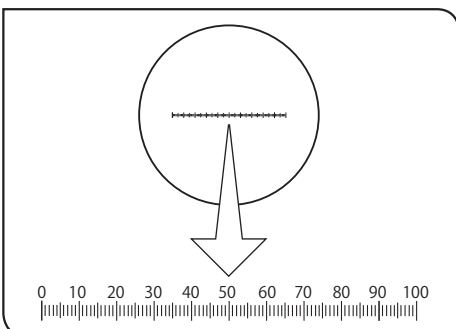

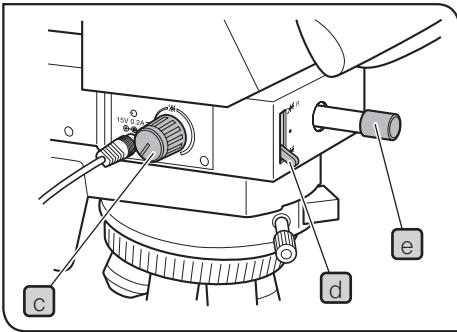

When the eyepiece is not equipped with the eyepiece micrometer

- 1 Rotate the pointer brightness control knob **c** of the discussion attachment in the clockwise direction to turn ON the pointer (⬆).
- 2 Set the pointer color switching lever **d** to the Up position (R). At this time, if the pointer cannot be observed in the field of view, move the pointer to the center of the field of view using the pointer control lever **e**.

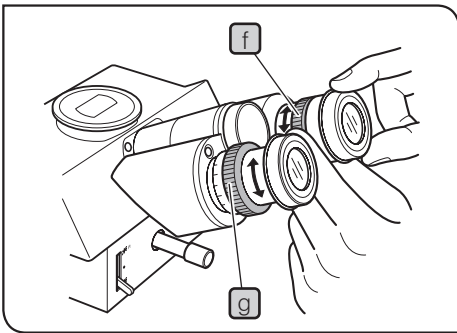

- 3 Rotate the diopter adjustment ring **f** of the right eyepiece to bring the pointer into focus.
- 4 Rotate the interpupillary distance adjustment ring **g** of the left eyepiece sleeve to bring the pointer into focus.
- 5 Set the pointer color switching lever **d** to the Down position (G), and perform **3** and **4** to bring the pointer into focus.
- 6 Place the specimen and rotate the coarse/fine focusing knobs to bring the specimen into focus.

2 Diopter adjustment of assistant observer

Perform the same operation as "Diopter adjustment of main observer". If the eyepiece is not equipped with the eyepiece micrometer, turn ON the pointer (⬆) and bring the specimen into focus at the main observer position.

3-3 Pointer operation

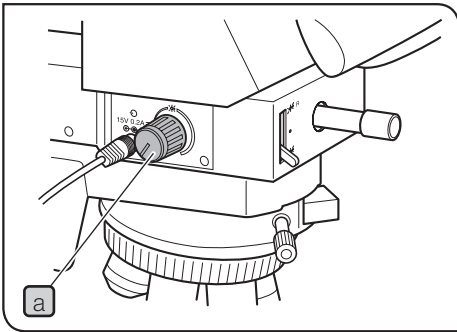

1 Adjusting the pointer brightness

TIP

The brightness adjustment range for the pointer of this product is set to support a dark specimen (e.g. specimen for fluorescence observation).

For this reason, when observing a bright specimen (e.g. specimen for brightfield observation), you may feel it difficult to identify the pointer unless rotating the brightness control knob to the maximum, but this is not a failure of this product.

- 1 Rotating the brightness control knob **a** of the pointer in clockwise direction makes the pointer brighter continuously.
- 2 Rotating the pointer brightness control knob **a** in counterclockwise direction until it stops turns OFF the pointer.

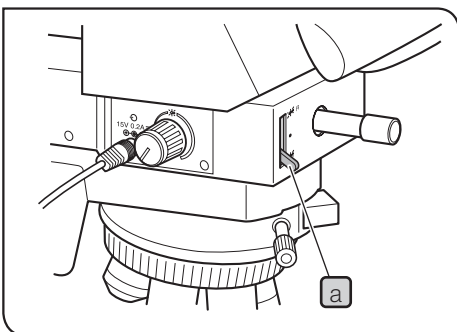

2 Selecting the pointer color

- 1 Using the pointer color switching lever **a**, select a pointer color which is clearly distinguishable from the color of the observed image.
 - Up position: Red
 - Middle position: Shielded
 - Down position: Green

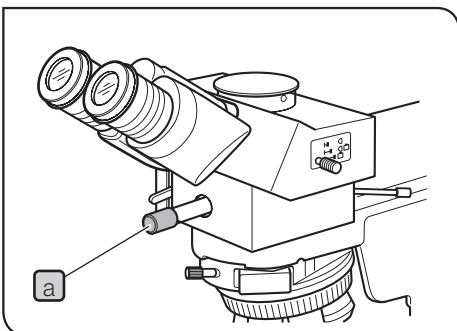

3 Moving the pointer

- 1 The main observer operates the pointer control lever **a** on the front of the discussion attachment to move the pointer to the desired position in the field of view.

TIP

Turn OFF the pointer when not in use. (For procedures to turn OFF the pointer, see **2** in "Adjusting the pointer brightness") If you do not want to display the pointer in the field of view during observation temporarily, move it away from the field of view or set the pointer color switching lever to the middle position.

3-4 Notes for image acquisition

This section describes special considerations for image acquisition in combination with discussion attachments.

- When combining the camera, attach the trinocular tube at the main observer position and attach the camera via camera adapter.
- If the pointer is in the metering area, the exposure during image acquisition may be affected. Refer to the instruction manual for camera in use and set the appropriate exposure time.
- If eyepieces at assistant observer positions are not covered with stray light prevention covers, the stray light entered from eyepieces may appear on the image. During image acquisition, cover the eyepieces **a** at assistant observer positions with stray light prevention covers **b**.

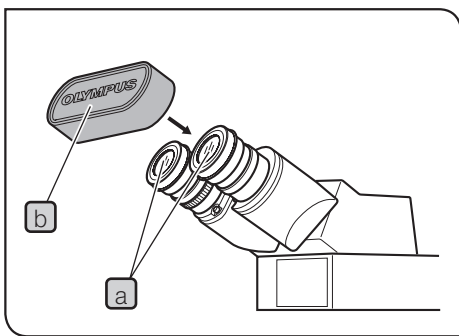

TIP

- You can acquire the image showing the pointer (↑) on the specimen.

4 Specifications

Item	Specification
Maximum number of observers	26 persons or less
Magnification of observation tube	1X
Orientation of observed image	When using the same type of observation tube, orientations of images observed by all observers are identical.
Maximum field number	22
Pointer switching	3 steps switchable (Up: Red. Middle: Shielded. Down: Green.)
Pointer movement	Joystick control (operable by main observer only)
Pointer power supply	AC adapter Rated Input : 100-240 V \sim 50-60 Hz 1.2 A (Max.) Output : 15 V \equiv 3.34 A Pointer Input : 15 V \equiv 0.2 A
Pointer lifetime	Lifetime: Designed for 5,000 hours or longer
Operating environment	<ul style="list-style-type: none"> • Indoor use • Altitude: Max. 2000 meters • Ambient temperature: 5 to 40 °C (41 to 104 °F) • Humidity: Max. 80% (31 °C or less) (without condensation) In case of over 31 °C (88 °F), the humidity in operating environment is decreased linearly through 70% at 34 °C (93 °F), 60% at 37 °C (99 °F), and to 50% at 40 °C (104 °F). • Supply voltage fluctuation: \pm10 % • Pollution degree: 2 (in accordance with IEC60664-1) • Installation (overvoltage) category: II (in accordance with IEC60664-1)

Installation space
for the system
for 18 persons

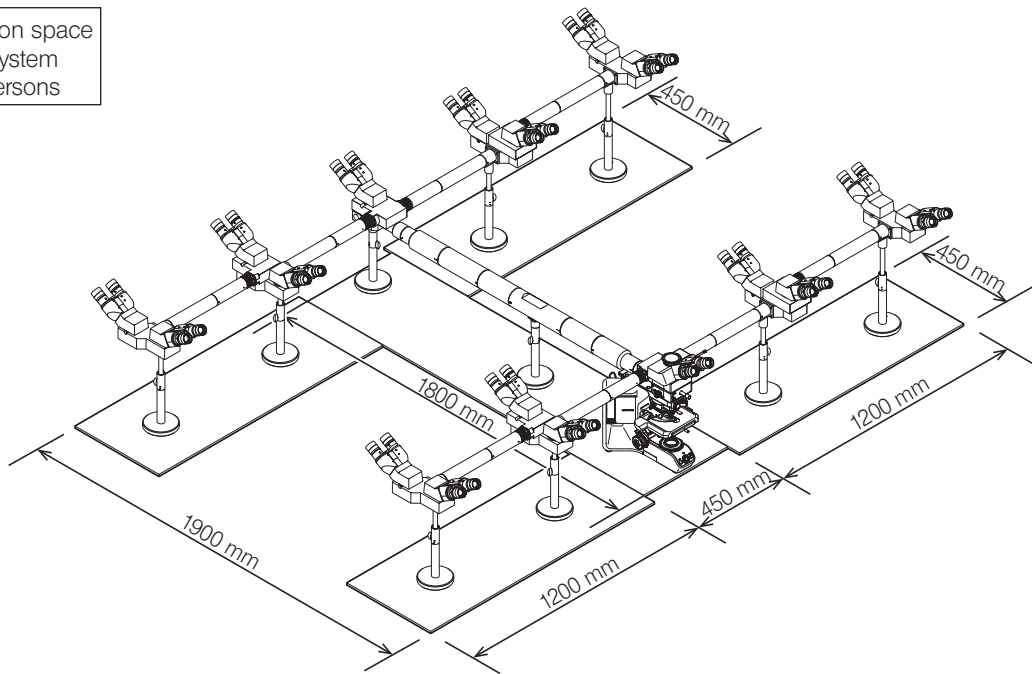

Installation space
for the system
for 26 persons

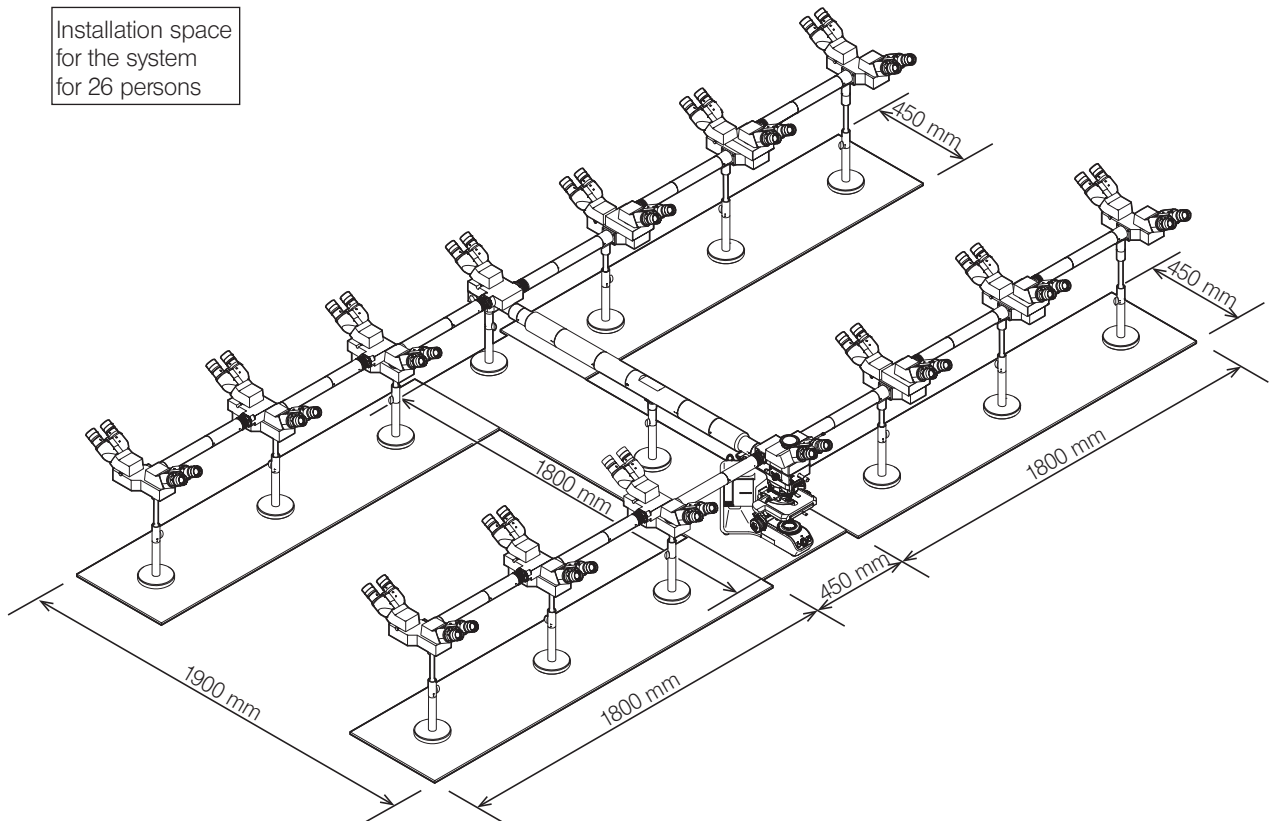

5 Assembly

In order to deliver our intended performance, we recommend you to request us to assemble the system.

Place each unit of the discussion system according to "1 Configuration of the discussion system and orientation of observed images" (page 5).

NOTE Install each unit of the discussion system on the desktop with the same height as much as possible.

- TIP**
- The installation space described in "4 Specifications" (page 13) is required for assembling and operating this system. Prepare the sufficient installation space.
 - The stand height can be adjusted visually, but you can adjust the height more precisely by measuring the height with a commercially-available level placed on the area of BX3-MDO18R and U-MDOSV as shown in the picture below.

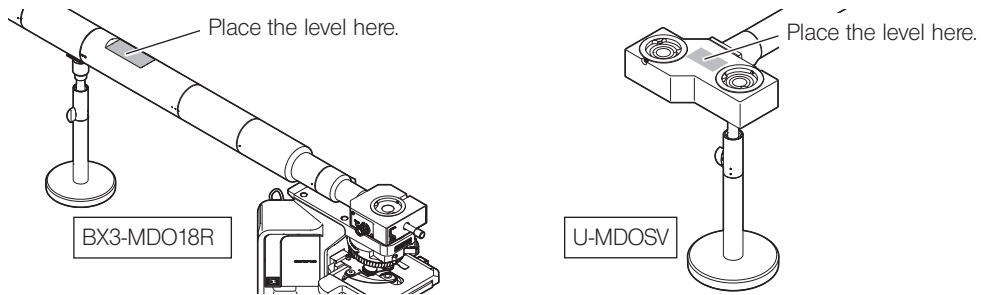

1 Attaching BX3-MDO18R

BX3-MDO18R is composed of 5 units shown by in the picture below. These 5 units are assembled and attached to the microscope frame.

- TIP** It is recommended to use the desk with a full length of 1,800 mm or more for installing the microscope frame and BX3-MDO18R.

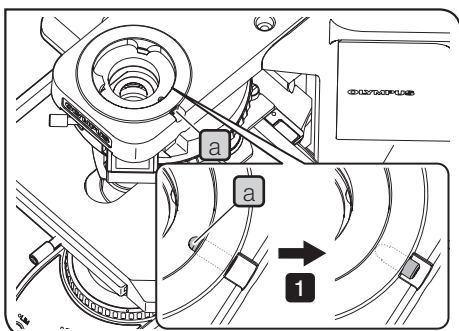
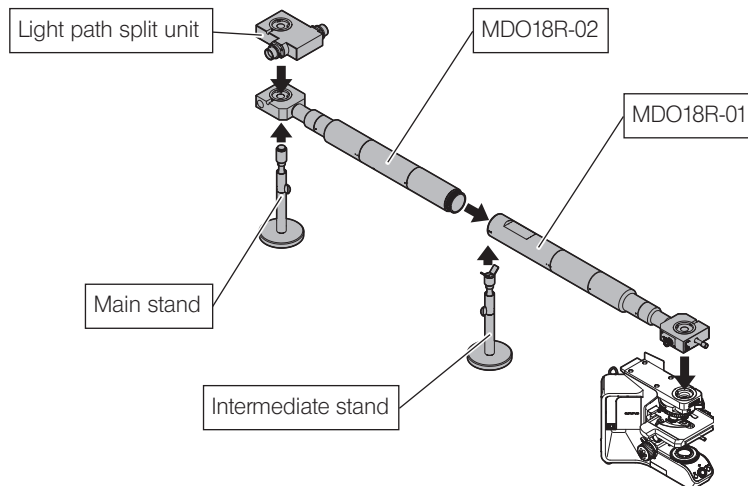

- 1** Loosen the clamping screw a of the standard arm (BX3-ARM) of the microscope until the clamping screw is not viewable from above (i.e. until there is no protrusion when touched with fingers).

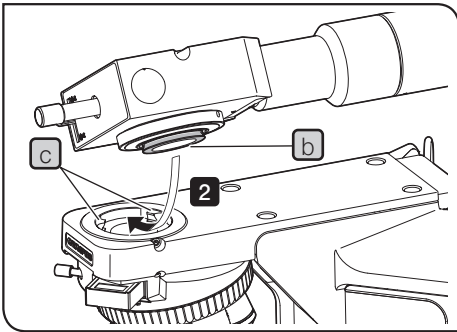

- 2** Insert the circular dovetail **b** of MDO18R-01 under two protrusions **c** in the mount on the standard arm of the microscope.

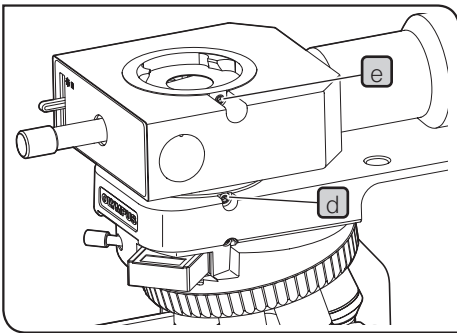

- 3** Tighten the clamping screw **d** of the standard arm to secure the standard arm firmly.

TIP Attach MDO18R-01 so that the clamping screw **d** of the standard arm of the microscope and the clamping screw **e** of MDO18R-01 are aligned in one line perpendicularly.

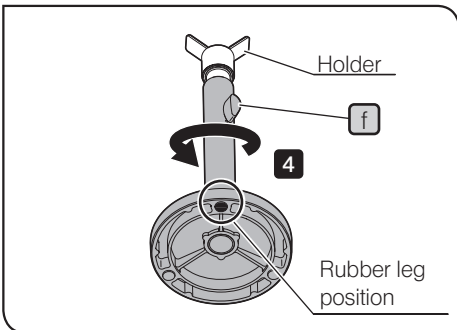

- 4** Loosen the stand height lock knob **f** of the intermediate stand. While looking at the back side of the base of the intermediate stand, rotate the ■ portion shown in the picture and place one of three rubber legs attached to the back side at the position as shown in the picture with respect to "Holder". After adjustment, tighten the stand height lock knob **f**.

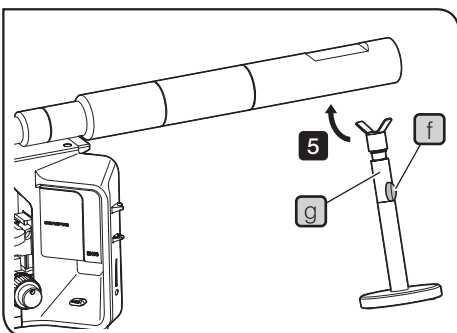

- 5** Place the intermediate stand **g** below MDO18R-01 so that the rubber leg specified in **4** comes to right under the tube of MDO18R-01.

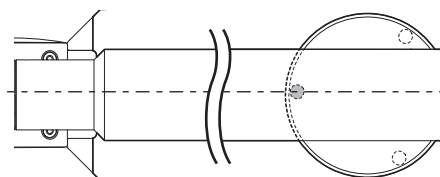

- 6** Loosen the stand height lock knob **f** of the intermediate stand to adjust the height of the intermediate stand while holding MDO18R-01 lightly from below, and tighten the stand height lock knob **f**.

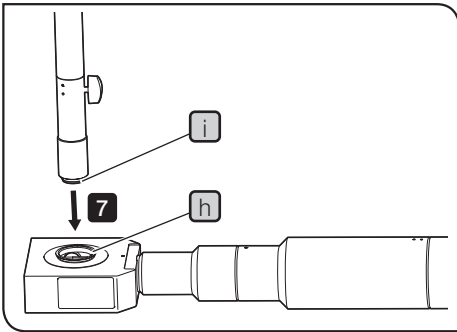

- 7** Place MDO18R-02 on the desk upside down and screw the **i** portion of the main stand into the mount screw hole **h** of MDO18R-01.

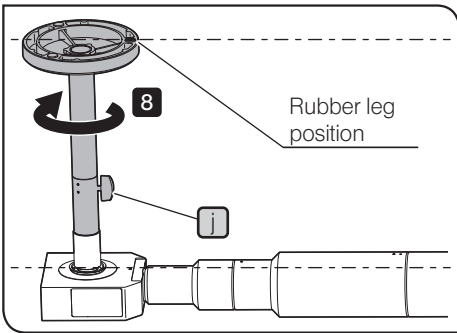

- 8** Loosen the stand height lock knob **j** of the main stand. Rotate the shaded portion shown in the picture and place one of three rubber legs attached to the back side of the base of the main stand so that it is parallel to the tube of MDO18R-02 as shown in the picture.

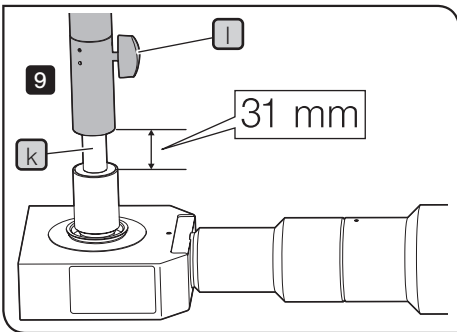

- 9** Move the shaded portion shown in the picture up and down so that the **k** portion of the main stand is 31 mm, and tighten the stand height lock knob **l**.

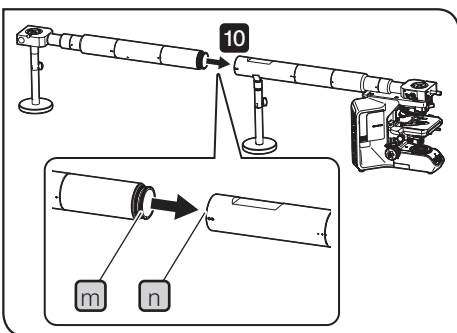

- 10** Return the vertical direction of MDO18R-02 where the main stand is attached to the original direction. Insert the **m** portion of MDO18R-02 into the mount **n** of MDO18R-01 attached to the microscope frame.

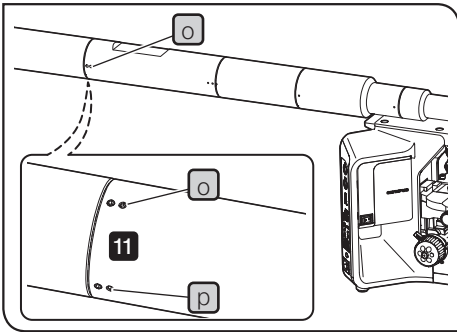

- 11** The screws **(o)** and **(p)** and screws **(q)** and **(r)** must be tightened in the specified order. First, hold MDO18R-02 inserted in **10** and while pushing MDO18R-02 toward MDO18R-01, check that there is no open space in the connection **(m)** and **(n)**. After confirming that there is no open space in the connection, tighten the screw **(o)** on the side surface of the tube and the screw **(p)** on the bottom surface of the tube using the provided Allen wrench.

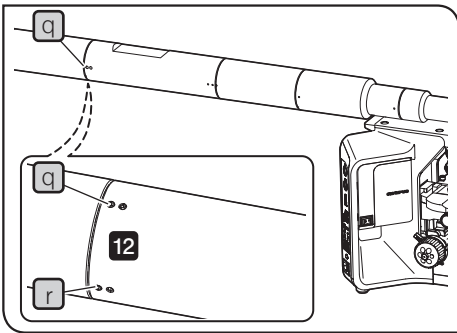

- 12** Next, pushing the tube toward the microscope frame side, tighten the screw **(q)** on the side surface of the tube and the screw **(r)** on the bottom surface of the tube to secure the tube using the provided Allen wrench.

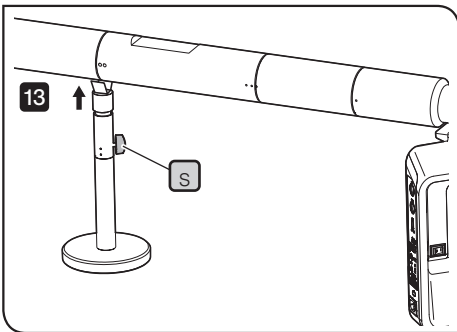

- 13** Loosen the stand height lock knob **(s)** of the intermediate stand, place the intermediate stand at the center of the tube, and adjust the height of the intermediate stand so that it touches the tube. Then, tighten the stand height lock knob **(s)**.

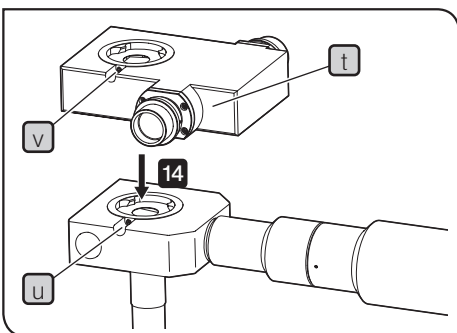

- 14** Attach the light path split unit **(t)** provided with BX3-MDO18R to the top of MDO18R-02 (at assistant observer position), and tighten the clamping screw **(u)** to secure the light path split unit.

TIP Attach the light path split unit **(t)** so that the clamping screw **(u)** of MDO18R-02 and the clamping screw **(v)** of the light path split unit are aligned in one line perpendicularly.

2 Attaching U-MDO10B3

The unit shown by  in the picture below indicates U-MDO10B3. U-MDO10B3 is attached at the main observer position (on top of microscope frame).

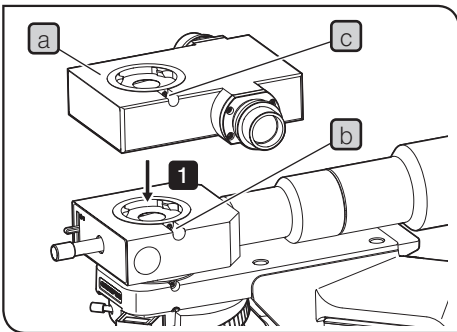
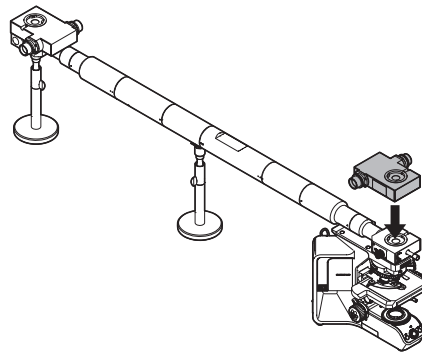



- 1 Attach U-MDO10B3 **a** to the top of MDO18R-01 (at main observer position) and tighten the clamping screw **b** to secure U-MDO10B3.

TIP Attach U-MDO10B3 **a** so that the clamping screw **b** of MDO18R-01 and the clamping screw **c** of U-MDO10B3 are aligned in one line perpendicularly.

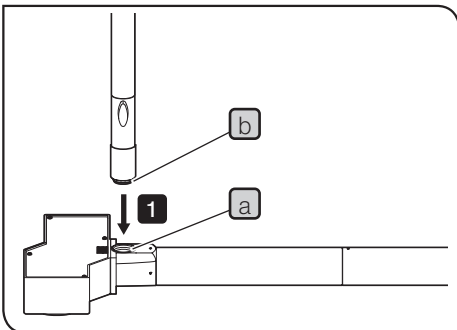
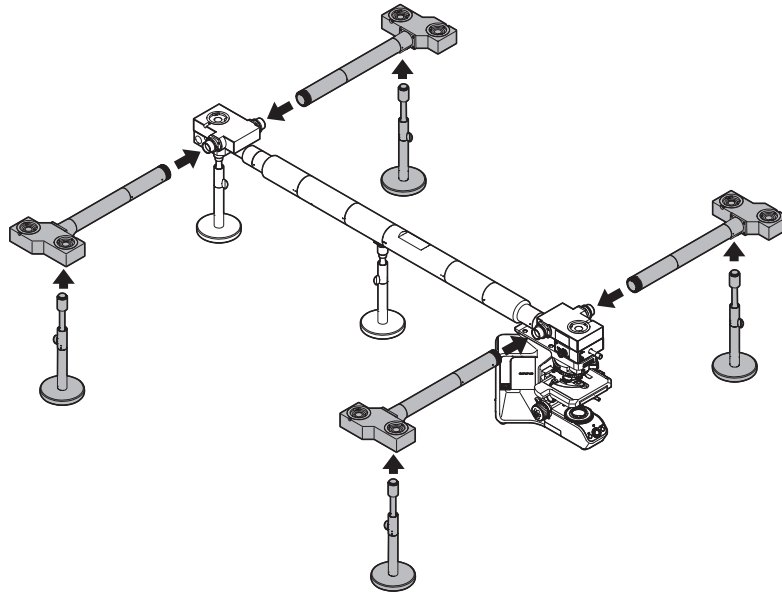

3 Attaching U-MDOSV

The units shown by  in the picture below indicate U-MDOSV. U-MDOSV are attached to the mounts (2 positions) on U-MDO10B3 at the main observer position (on top of microscope frame) and to the mounts (2 positions) on the light path split unit at the assistant observer position.

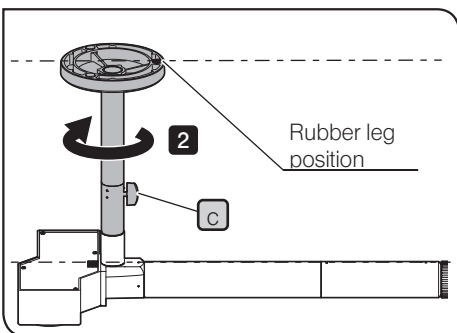

- 1 Place U-MDOSV on the desk upside down and screw the  portion of the stand into the mount screw hole  of U-MDOSV.



- 2 Loosen the stand height lock knob . Rotate the  portion shown in the picture and place one of three rubber legs attached to the back side of the base of the stand so that it is parallel to the tube of U-MDOSV as shown in the picture.

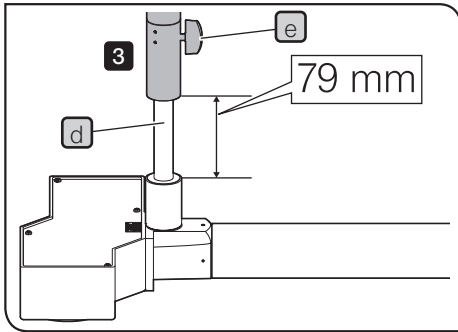

- 3** Move the portion shown in the picture up and down so that the d portion of the stand is 79 mm, and tighten the stand height lock knob e.

TIP If there is a difference in height between the desk top surface where the microscope frame is installed and the desk top surface where U-MDOSV is installed, adjust the length of the d portion of the stand. For example, if the height difference is 5 mm (if the desk top surface of the microscope frame is higher than the desk top surface of U-MDOSV), d will be 84 mm.

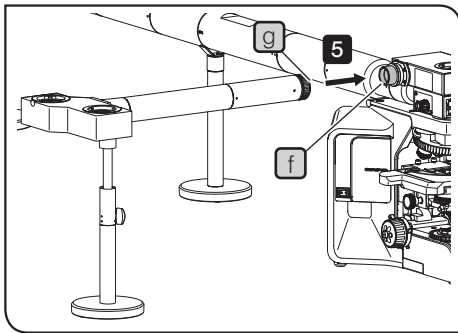

- 4** Remove the caps from the mounts f on U-MDO10B3 or the light path split unit and the caps from the mounts g on U-MDOSV.

- 5** Return the vertical direction of U-MDOSV where the stand is attached to the original direction. Insert g of U-MDOSV into the mount f on U-MDO10B3 or light path split unit completely to the end.

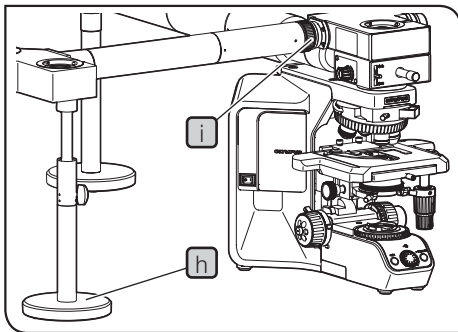

- 6** While holding the base h of the stand firmly with your hand, rotate the mount ring i to secure U-MDOSV to U-MDO10B3 or the light path split unit.

NOTE After the mount ring i is rotated completely, check that the stand is installed on the desk securely. Insert a sheet of paper between the base of the stand and the desk. If the paper touches three rubber legs, the stand is installed securely. If the paper does not touch even one rubber leg, perform **6** again.

4 Attaching BX3-MDOE

The units shown by  in the picture below indicate BX3-MDOE. BX3-MDOE are attached to the mounts (4 positions in total) on U-MDOSV.

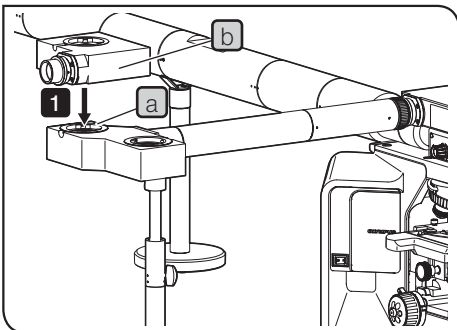
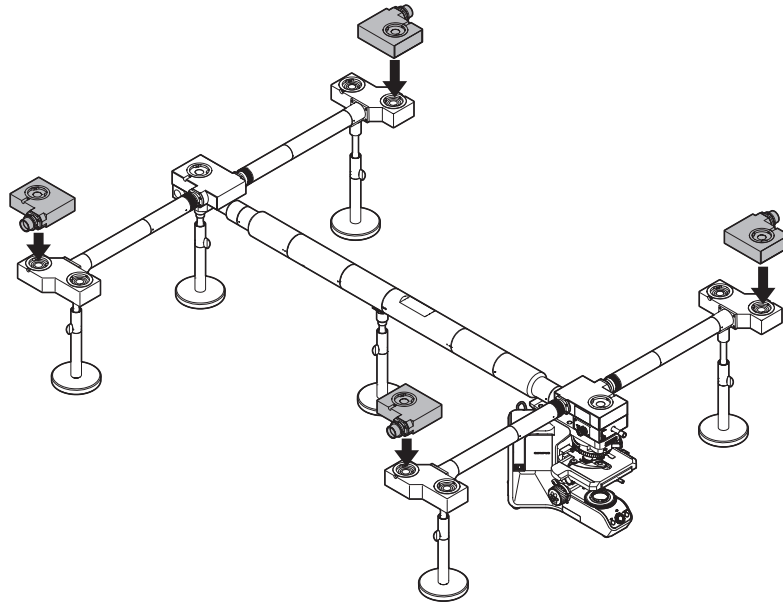

1 Attach BX3-MDOE **b** to the tube mount **a** on U-MDOSV.

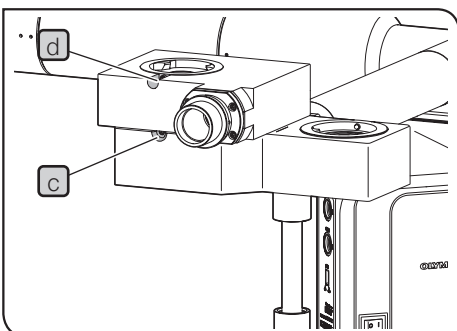



2 Tighten the clamping screw **c** to secure BX3-MDOE to U-MDOSV. Attach BX3-MDOE so that the clamping screw **c** of U-MDOSV and the clamping screw **d** of BX3-MDOE are aligned in one line perpendicularly.

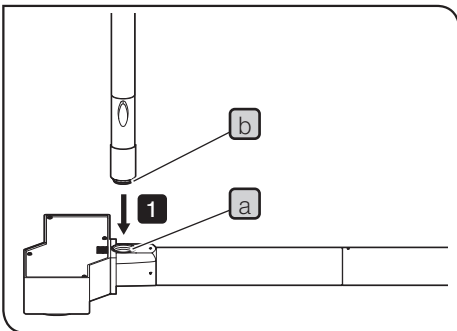
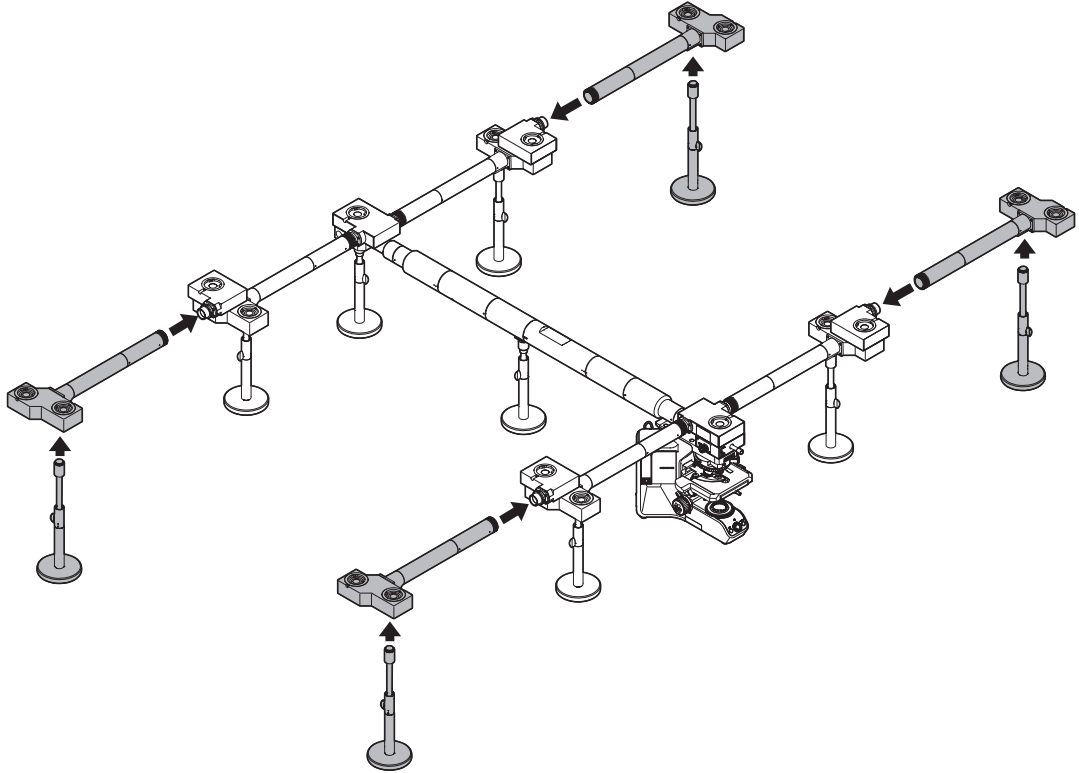

5 Attaching U-MDOSV (Extension)

The units shown by  in the picture below indicate U-MDOSV. U-MDOSV are attached to the mounts (4 positions in total) on BX3-MDOE.

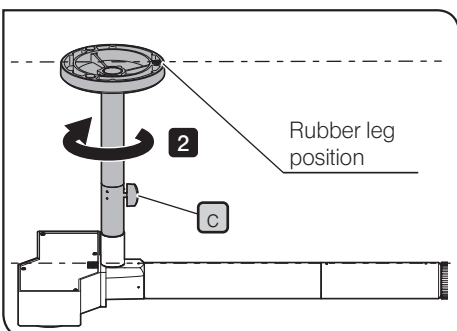

- 1 Place U-MDOSV on the desk upside down and screw the  part of the stand into the mount screw hole  of U-MDOSV.



- 2 Loosen the stand height lock knob . Rotate the  portion shown in the picture and place one of three rubber legs attached to the back side of the base of the stand so that it is parallel to the tube of U-MDOSV as shown in the picture.

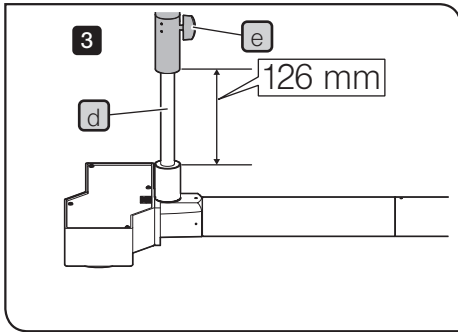

- 3** Move the  portion shown in the picture up and down so that the **d** portion of the stand is 126 mm, and tighten the stand height lock knob **e**.

TIP If there is a difference in height between the desk top surface where the microscope frame is installed and the desk top surface where U-MDOSV (extension) is installed, adjust the length of the **d** portion of the stand. For example, if the height difference is 5 mm (if the desk top surface of the microscope frame is higher than the desk top surface of U-MDOSV (extension)), **d** will be 131 mm.

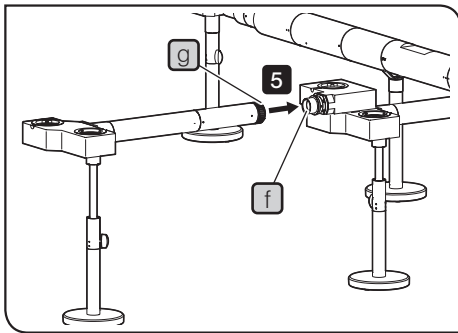

- 4** Remove the cap from the mount **f** on BX3-MDOE and the cap from the mount **g** on U-MDOSV.

- 5** Return the vertical direction of U-MDOSV where the stand is attached to the original direction. Insert **g** of U-MDOSV into the mount **f** on BX3-MDOE completely to the end.

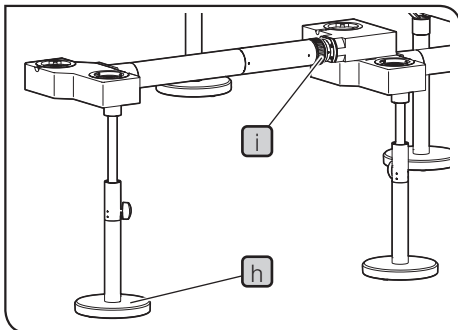

- 6** While holding the base **h** of the stand firmly with your hand, rotate the mount ring **i** to secure U-MDOSV to BX3-MDOE.

NOTE After the mount ring **i** is rotated completely, check that the stand is installed on the desk securely. Insert a sheet of paper between the base of the stand and the desk. If the paper touches three rubber legs, the stand is installed securely. If the paper does not touch even one rubber leg, perform **6** again.

6 Extending the system for 26 persons

The units shown by  in the picture below indicate BX3-MDOE and U-MDOSV. The system for 18 persons can be extended to the system for 26 persons by attaching BX3-MDOE and U-MDOSV to four positions in total. For attaching procedures, see "Attaching BX3-MDOE" (page 21) and "Attaching U-MDOSV (Extension)" (page 22). Note that it is necessary to attach the stand raising parts to the stand to be attached to U-MDOSV. Refer to the following instructions and attach the stand raising parts to the stand in advance.

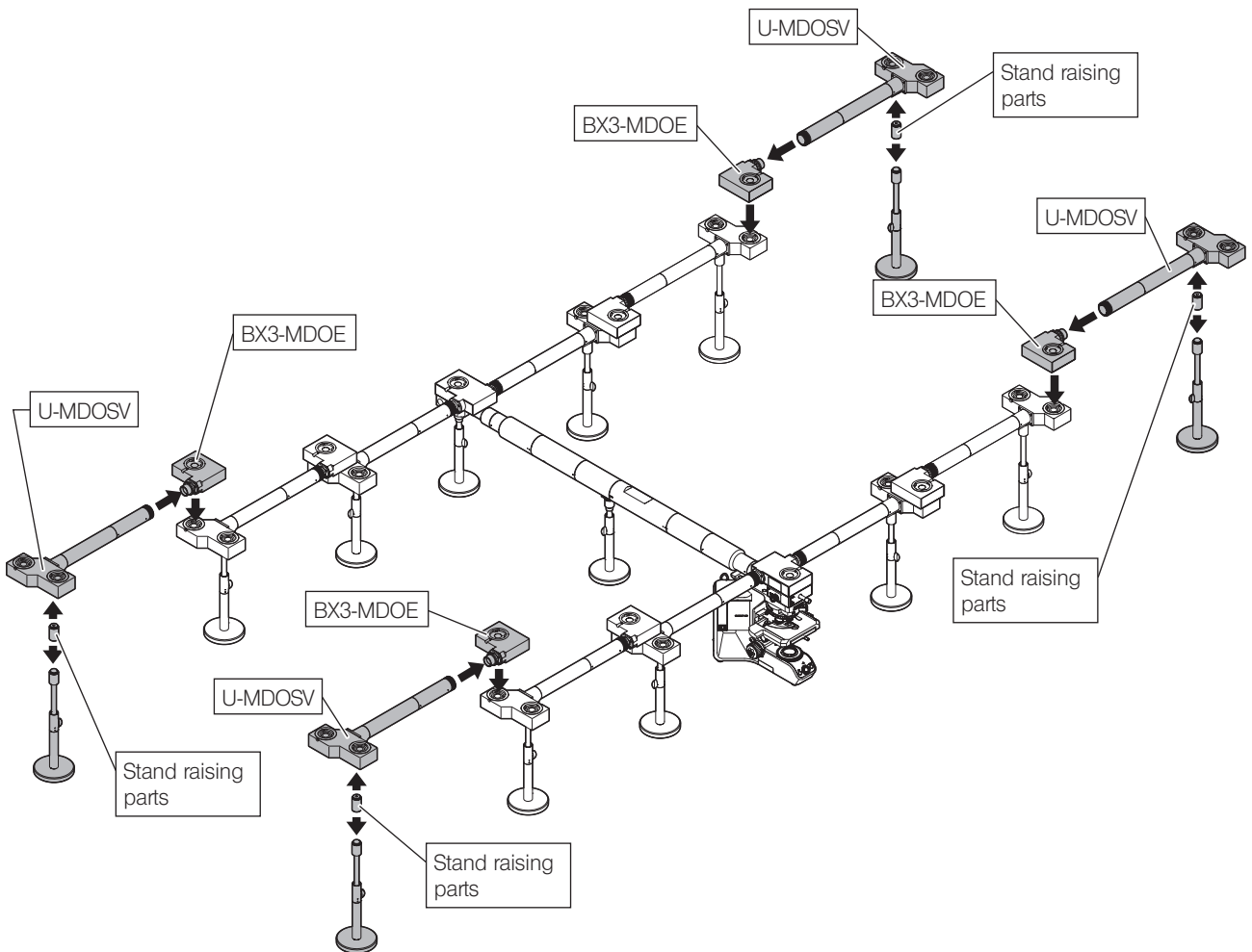

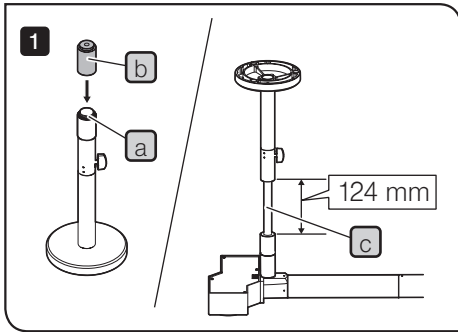

Attaching the stand raising parts **b**

1 Screw the stand raising parts **b** into the top **a** of the stand.

Height of the **c** portion of the stand

Move the stand shown in the picture up and down so that the **c** portion of the stand is 124 mm.

TIP If there is a difference in height between the desk top surface where the microscope frame is installed and the desk top surface where U-MDOSV to be used for extending to the system for 26 persons is installed, adjust the length of the **c** portion of the stand. For example, if the height difference is 5 mm (if the desk top surface of the microscope frame is higher than the desk top surface of U-MDOSV (extension) to be used for extending to the system for 26 persons), **c** will be 129 mm.

7 Attaching the observation tube

The units shown by  in the picture below indicate the observation tubes for the main observer and assistant observers. The observation tubes are attached to the tube mounts.

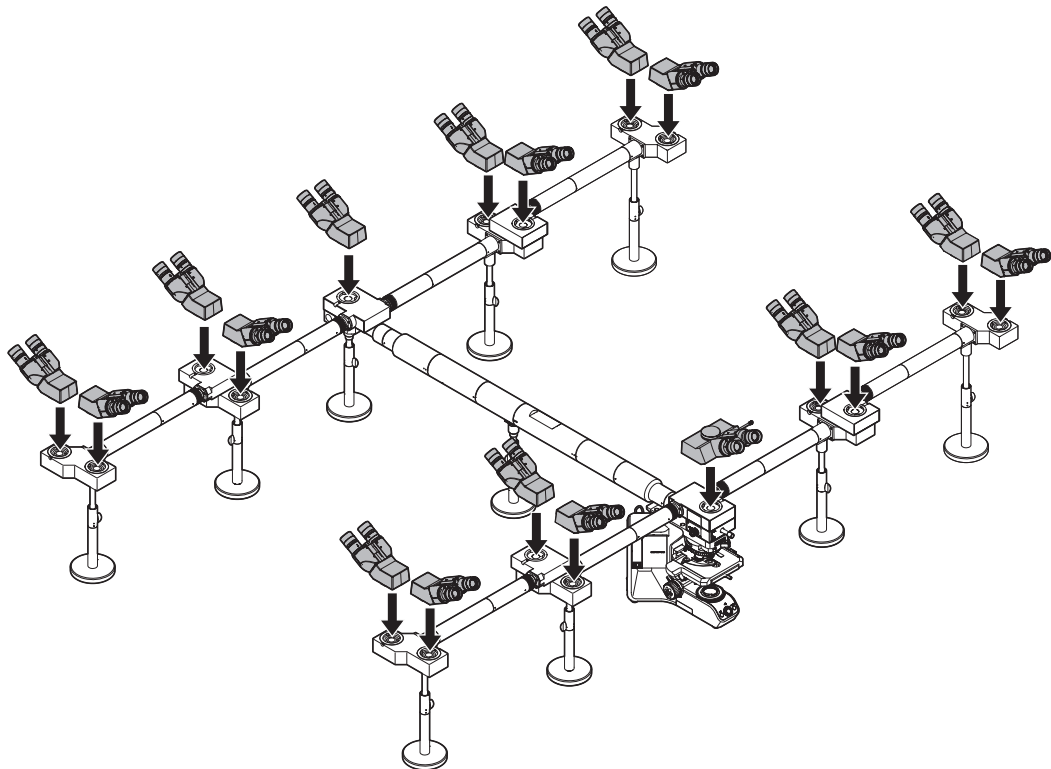

This illustration shows the positions to attach observation tubes in the case of the system for 18 persons. In case of the system for 26 persons, the number of positions to attach observation tubes increases, but the attaching procedures are the same as those of the system for 18 persons.

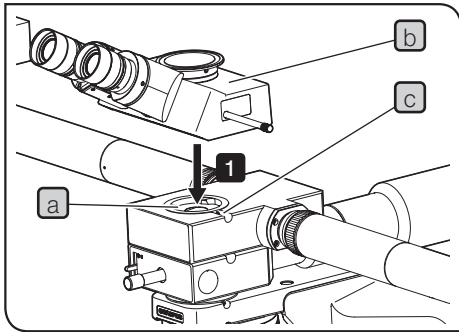

- 1 Attach the observation tube **b** for the main observer to the tube mount **a** on U-MDO10B3 at the main observer position, and tighten the clamping screw **c** to secure the observation tube.

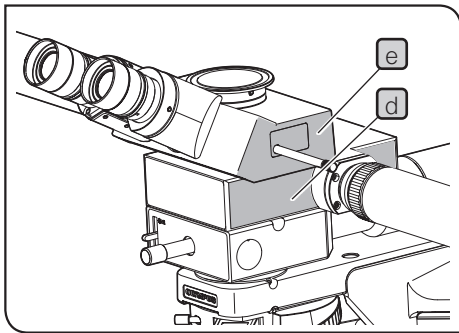

- TIP** Attach the observation tube so that the side surface **d** of U-MDO10B3 is parallel to the side surface **e** of the observation tube. If the observation tube is not attached in the proper direction, the orientation of the image observed by assistant observers differs from that observed by the main observer. (For the orientation of the observed image, see "1 Configuration of the discussion system and orientation of observed images" (page 5).

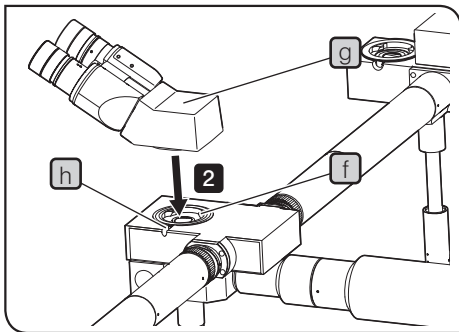

- 2 Attach the observation tube **g** for the assistant observer to the tube mount **f** on the light path split unit provided with BX3-MDO18R at the assistant observer position, and tighten the clamping screw **h** to secure the observation tube.

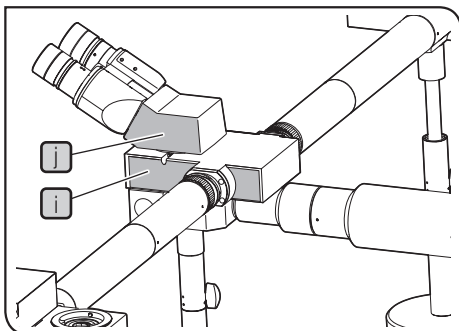

- TIP** Attach the observation tube so that the side surface **i** of the light path split unit is parallel to the side surface **j** of the observation tube.

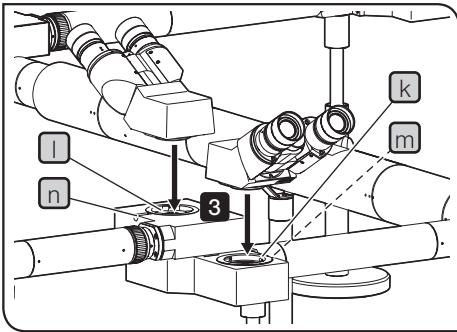

3 Attach the observation tube prepared for the assistant observer to the tube mount **k** on U-MDOSV and the tube mount **l** on BX3-MDOE, and tighten the clamping screws **m** and **n** to secure the observation tube.

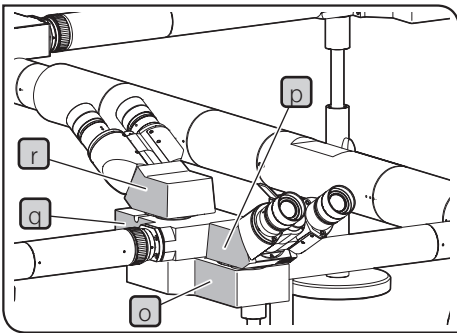

TIP Attach the observation tube so that the side surface **o** of U-MDOSV is parallel to the side surface **p** of the observation tube and also the side surface **q** of BX3-MDOE is parallel to the side surface **r** of the observation tube.

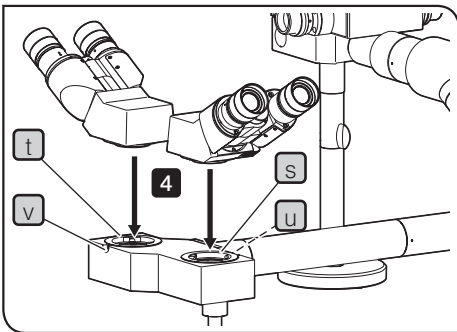

4 Attach the observation tube prepared for the assistant observer to the tube mounts **s** and **t** on U-MDOSV, and tighten the clamping screws **u** and **v** to secure the observation tube.

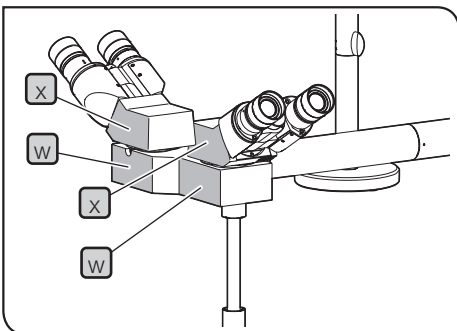

TIP Attach the observation tube so that the side surface **w** of U-MDOSV is parallel to the side surface **x** of the observation tube.

8

Attaching the eyepieces

Procedures to attach eyepieces are same as those with normal microscopes.

TIP

Combine observation tubes and eyepieces so that the diopter adjustment mechanism is equipped to light paths of both eyes of the main observer and assistant observers.

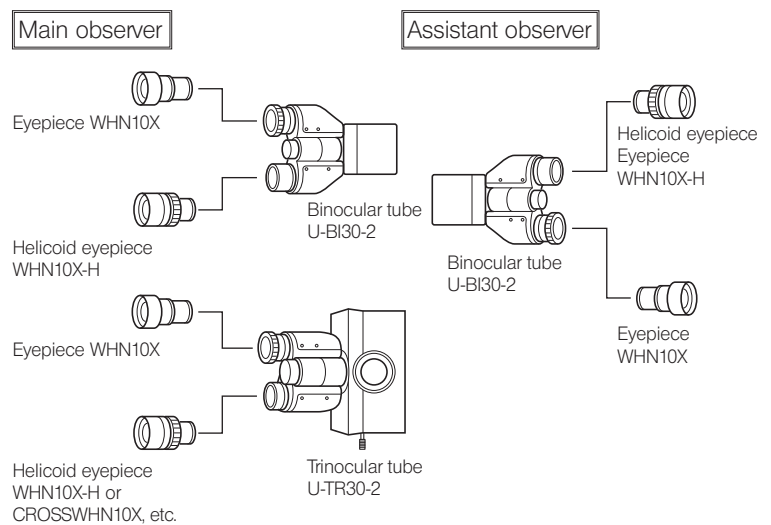

9 Adjusting the stand height

Adjustment order

Adjust the stand height in the following order.

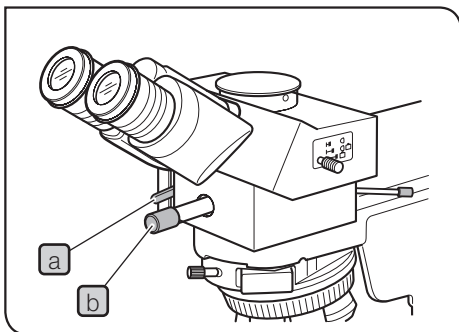
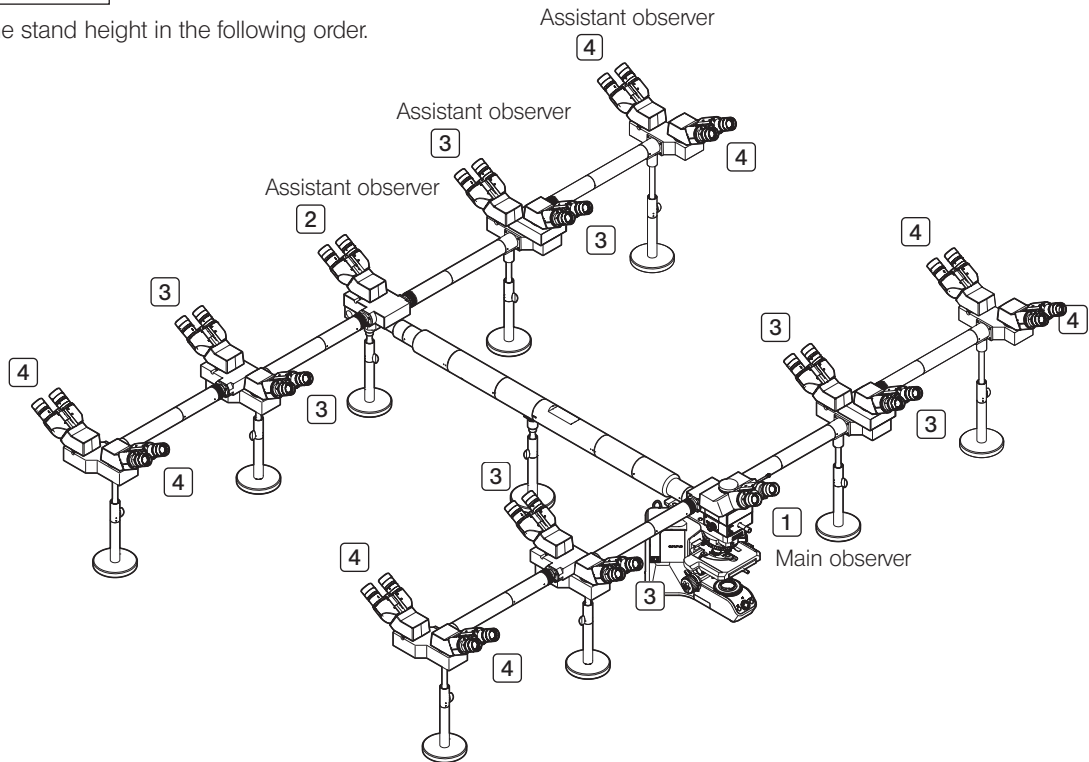

- 1 Look through the eyepieces at the main observer position **1** and display the pointer using the pointer color switching lever **a**. Use the pointer control lever **b** to move the pointer to the center of the field of view. (For detailed operating procedures of the pointer color switching lever and the pointer control lever, see "3-3 Pointer operation" (page 10).)

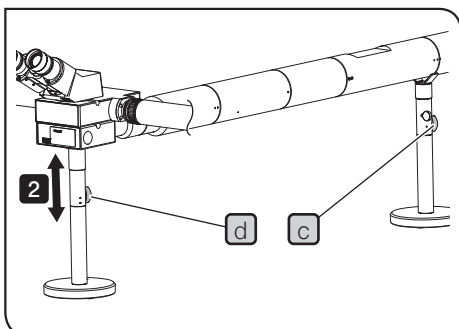

- 2 Look through the eyepieces at the assistant observer position **2**. If there is a deviation in the displayed pointer position, adjust the stand height with the stand height lock knob **c** of the intermediate stand and the stand height lock knob **d** of the main stand so that the pointer comes to the center of the field of view.
- 3 Check the deviation of the pointer displayed at the assistant observer position in the order from **3** to **4**. If there is a deviation, adjust the stand height in the same procedures as **2**.

TIP

• Be sure to adjust the stand height.

If the stand height is not adjusted, following phenomena may appear.

- The periphery areas of the field of view of the assistant observer are cut off.
- The deviation in the field of view occurs between the main observer and the assistant observer.
- The field of view of the assistant observer is colored.

NOTE

The farther away from the center of the system you apply the force to the observation tube, the larger the force to be applied to the entire system becomes. Do not apply the excess force on the observation tube carelessly.

10 Connecting the AC adapter

⚠ CAUTION

• Always use the AC adapter and power cord provided by us. If the proper AC adapter and the power cord are not used, the electric safety and the EMC (Electro-Magnetic Compatibility) performance of the product can not be assured. If no power cord is provided, please select the proper power cord by referring to the section “Proper selection of the power cord” at the end of this instruction manual.

• The power cord should be connected to a grounded, 3-conductor power outlet. If the power outlet is not grounded properly, we can no longer warrant the electrical safety performance of the equipment.

NOTE

• Before connecting the AC adapter, rotate the pointer brightness control knob in counterclockwise direction to set to the OFF position.

• The power cord is vulnerable when bent or twisted. Never subject it to excessive force.

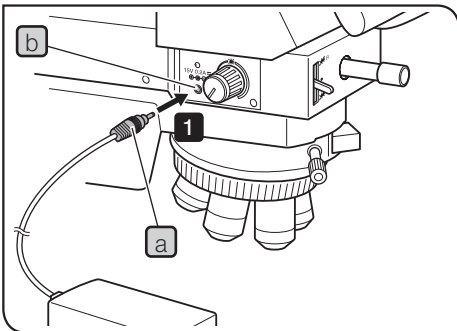

1 Connect the AC adapter's output plug **a** completely to the AC adapter input connector **b** on the left side panel of the discussion observation tube.

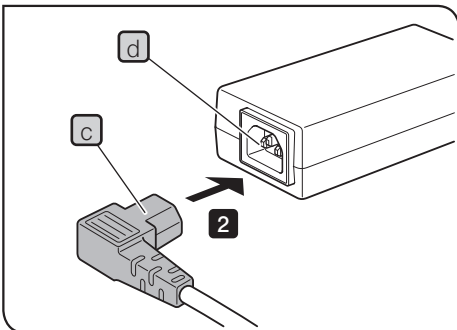

2 Insert the power cord connector **c** to the AC adapter's input connector **d**.

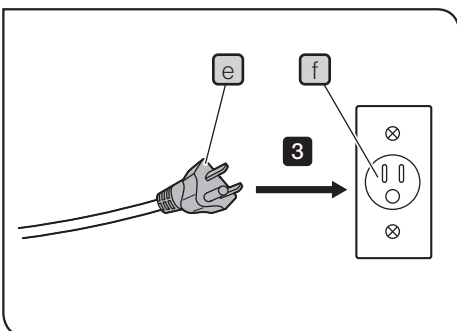

3 Connect the power cord's plug **e** to the power outlet **f** on the wall.

11 Attaching the cord stopper

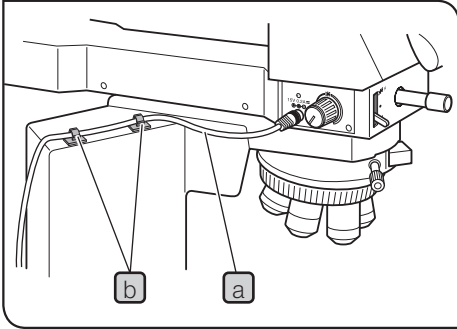

To prevent the AC adapter cord **a** from getting in the way of microscope operation and from contacting the lamp housing, peel off the backing paper from the stickers of the provided cord stopper **b** (2 pcs.) and attach them. Be sure to clean the place to attach the cord stopper with absolute alcohol, etc. in advance.

■ Proper selection of the power supply cord

If no power supply cord is provided, please select the proper power supply cord for the equipment by referring to "Specifications" and "Certified Cord" below:

Caution : In case you use a non-approved power supply cord for our products, we can no longer warrant the electrical safety of the equipment.

Specifications

Voltage rating	125 V AC (for 100-120 V AC area) or, 250 V AC (for 220-240 V AC area)
Current rating	6 A minimum
Temperature rating	60 °C minimum
Length	3.05 m maximum
Fittings configuration	Grounding type attachment plug cap. Opposite terminates in molded-on IEC configuration appliance coupling.

Table 1 Certified cord

A power supply cord should be certified by one of the agencies listed in Table 1 , or comprised of cordage marked with an agency marking per Table 1 or marked per Table 2. The fittings are to be marked with at least one of the agencies listed in Table 1. In case you are unable to buy locally the power supply cord which is approved by one of the agencies mentioned in Table 1, please use replacements approved by any other equivalent and authorized agencies in your country.



















Country	Agency	Certification mark	Country	Agency	Certification mark
Argentina	IRAM		Italy	IMQ	
Australia	SAA		Japan	JET, JQA,	
Austria	ÖVE		Netherlands	KEMA	
Belgium	CEBEC		Norway	NEMKO	
Canada	CSA		Spain	AEE	
Denmark	DEMKO		Sweden	SEMKO	
Finland	FEI		Switzerland	SEV	
France	UTE		United Kingdom	ASTA BSI	
Germany	VDE		USA.	UL	
Ireland	NSAI				

Table 2 HAR flexible cord

Approval organizations and cordage harmonization marking methods

Approval organization	Printed or embossed harmonization marking (May be located on jacket or insulation of internal wiring)	Alternative marking utilizing black-red-yellow thread (Length of color section in mm)		
		Black	Red	Yellow
Comite Electrotechnique Belge (CEBEC)	CEBEC <HAR>	10	30	10
Verband Deutscher Elektrotechniker (VDE) e.V. Prüfstelle	<VDE> <HAR>	30	10	10
Union Technique de l'Electricite' (UTE)	USE <HAR>	30	10	30
Instituto Italiano del Marchio di Qualita' (IMQ)	IEMMEQU <HAR>	10	30	50
British Approvals Service for Electric Cables (BASEC)	BASEC <HAR>	10	10	30
N.V. KEMA	KEMA-KEUR <HAR>	10	30	30
SEMKO AB Svenska Elektriska Materielkontrollanstalter	SEMKO <HAR>	10	10	50
Österreichischer Verband für Elektrotechnik (ÖVE)	<ÖVE> <HAR>	30	10	50
Danmarks Elektriske Materialkontroll (DEMKO)	<DEMKO> <HAR>	30	10	30
National Standards Authority of Ireland (NSAI)	<NSAI> <HAR>	30	30	50
Norges Elektriske Materielkontroll (NEMKO)	NEMKO <HAR>	10	10	70
Asociacion Electrotecnica Y Electronica Espanola (AEE)	<UNED> <HAR>	30	10	70
Hellenic Organization for Standardization (ELOT)	ELOT <HAR>	30	30	70
Instituto Portages da Qualidade (IPQ)	np <HAR>	10	10	90
Schweizerischer Elektro Technischer Verein (SEV)	SEV <HAR>	10	30	90
Elektriska Inspektoratet	SETI <HAR>	10	30	90

Underwriters Laboratories Inc. (UL)
Canadian Standards Association (CSA)

SV, SVT, SJ or SJT, 3 X 18AWG
SV, SVT, SJ or SJT, 3 X 18AWG

This product is manufactured by **EVIDENT CORPORATION** effective as of Apr. 1, 2022.
Please contact our "Service Center" through the following website for any inquiries or issues related to this product.

EVIDENT CORPORATION

6666 Inatomi, Tatsuno-machi, Kamiina-gun, Nagano 399-0495, Japan

(Life science solutions)

Service Center

<https://www.olympus-lifescience.com/support/service/>



(Life science solutions)

Our Website

<https://www.olympus-lifescience.com>



(Industrial solutions)

Service Center

<https://www.olympus-ims.com/service-and-support/service-centers/>



(Industrial solutions)

Our Website

<https://www.olympus-ims.com>

