

BX-URA2
BX-RFA
U-LH100HGAPO
U-LH100HG
U-RFL-T
U-25ND6-2
U-25ND25-2
U-25ND50-2
U-RSL6
U-RSL6EM
BX-RFSS
U-EXBABG
U-EXBAUB
U-EXBAUG

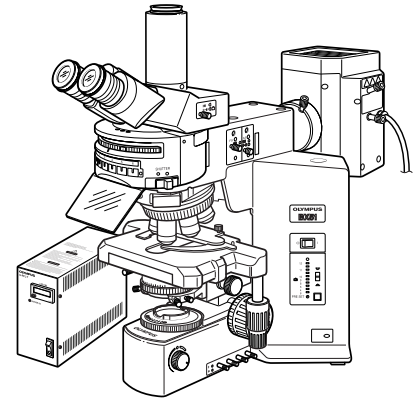

INSTRUCTIONS

REFLECTED FLUORESCENCE SYSTEM

This instruction manual is for the Evident Reflected Fluorescence System. To ensure the safety, obtain optimum performance and to familiarize yourself fully with the use of this system, we recommend that you study this manual thoroughly before operating the microscope. Retain this instruction manual in an easily accessible place near the work desk for future reference.

CONTENTS

Correct assembly and adjustments are critical for the reflected fluorescence system to exhibit its full performance. If you are going to assemble the reflected fluorescence system yourself, please carefully read section 9, "ASSEMBLY" (pages 30 to 33).

IMPORTANT – Be sure to read this section for safe use of the equipment. – 1-3

I. REFLECTED FLUORESCENCE OBSERVATION

1	NOMENCLATURE	4,5
2	REFLECTED FLUORESCENCE OBSERVATION PROCEDURE	6,7
3	USING THE CONTROLS	8-15
1	General Precautions for Observation	8
2	Selecting the Fluorescence Mirror Unit	8-10
3	Objectives for Various Observation Modes	10,11
4	Turning the Power Supply Unit On	11
5	Centering the Field Iris Diaphragm	12
6	Centering the Aperture Iris Diaphragm	13
7	Centering the Mercury Burner	14,15
8	Mounting the ND Filters	15
4	SIMULTANEOUS FLUORESCENCE OBSERVATIONS	16
1	Simultaneous Reflected Fluorescence and Phase Contrast Observations	16
2	Simultaneous Reflected Fluorescence and Transmitted Light Nomarski Differential Interference Contrast (DIC) Observations	16
5	TROUBLESHOOTING GUIDE	17
6	SPECTRAL CHARACTERISTICS OF FILTERS	18-22
7	SPECIFICATIONS	23

8 OPTIONAL MODULES 24-29

- 1** 6-Position Filter Slider U-RSL6 24,25
- 2** 6-Position Barrier Filter Slider U-RSL6EM 26
- 3** Rectangle Field Stop BX-RFSS (for exclusive use with the BX-RFA) 27
- 4** Exciter Balancers U-EXBABG/EXBAUB/EXBAUG (for exclusive use with the BX-RFA) 28,29

9 ASSEMBLY – See this section for the replacement of the light bulb. – 30-33

- 9-1 Assembly Diagram 30
- 9-2 Detailed Assembly Procedures 31-33

II. REFLECTED OBSERVATIONS (BX-URA2 Only)

1 CONFIGURATION OF REFLECTED OBSERVATION SYSTEM 34

2 ASSEMBLY 35

3 FIELD IRIS AND APERTURE IRIS DIAPHRAGM ADJUSTMENTS 35,36

4 OBSERVATIONS 37-40

- 4-1 Reflected Light Brightfield/Darkfield Observations 37
- 4-2 Reflected Light Nomarski Differential Interference Contrast (DIC) Observation 38-40
- 4-3 Reflected Light Simple Polarized Light Observation 40

5 OPTICAL CHARACTERISTICS «UIS2 Series for Reflected Light Observation» 41,42

6 TROUBLESHOOTING GUIDE 43

- PROPER SELECTION OF THE POWER SUPPLY CORD 44,45

7 LAMP HOUSING INSPECTION SHEET 46

IMPORTANT

This system employs a UIS2/UIS (Universal Infinity System) optical design, and should be used only with UIS2/UIS microscopes, eyepieces, objectives and condensers for the BX2 series. (Some of the modules designed for the BX series and objectives/eyepieces for the UIS series are also usable. For details, please consult Evident or the catalogues.) Less than optimum performance may result if inappropriate accessories are used.

The use of a universal reflected fluorescence illuminator has enabled the installation of necessary fluorescence mirror units. By combining the microscopy techniques as shown below, this system can efficiently be used to find fluorescence emission in any area of cells:

1. Reflected fluorescence observation + Transmitted light phase contrast observation
2. Reflected fluorescence observation + Transmitted Nomarski Differential Interference Contrast (DIC) observation
3. Reflected fluorescence observation + Transmitted Light Observation

In addition, the following observations are also by installing a general reflected light observation unit (BX-URA2 only):

1. Reflected brightfield/darkfield observations
2. Reflected Nomarski DIC observation
3. Reflected simplified polarized light observation

This manual describes the instructions for I. Reflected Fluorescence Observations in the first half and those for II. Reflected Light Observations in the second half.





Please find the pages giving you the appropriate instructions for your observation.

SAFETY PRECAUTIONS

1. This system is composed of precision instruments. Handle it with care and avoid subjecting it to sudden or severe impact.
2. The ultrahigh-pressure mercury burner used should be the USH-103OL DC burner (mfd. by USHIO, Inc.) or the HBO103W/2 burner (mfd. by OSRAM) that Evident supplies.
3. Make sure that a mercury burner is attached and that cables are plugged in firmly.
4. The inside of the lamp housing is very hot and hazardous during lighting and for about 10 minutes after turning off. Do not open the lamp housing in this period. (Page 11)
5. Do not apply excessive force to the stoppers which are provided for some functions. Otherwise, the stopper or equipment may be damaged.
6. Do not attempt to open or disassemble the power supply unit because it includes high voltage parts inside.
7. Always use the power cord provided by Evident. If no power cord is provided, please select the proper power cord by referring to the section "PROPER SELECTION OF THE POWER SUPPLY CORD" at the end of this instruction manual. If the proper power cord is not used, product safety and performance cannot be guaranteed.
Before plugging the power cord to the power outlet, make sure that the main switch of the power supply unit is set to "○" (OFF).
8. To ensure safety, be sure to **ground** the power supply unit. Otherwise, Evident can no longer warrant the electrical safety performance of the system.
9. Before opening the lamp housing for replacement of the burner or any other internal part, set the main switch to "○" (OFF), then unplug the lamp housing connection cable from the power supply unit, and wait for more than 10 minutes until the lamp housing cools down.
10. The top panel of the lamp housing becomes very hot during operation. To prevent fire hazard, do not block the ventilation through the top panel.
11. The standard service life of the lamp housing is eight (8) years of use or 20,000 hours of total power ON period, whichever is the shorter period.
For details, see Inspection Sheet on page 46.



Safety Symbols

The following symbols are found on the microscope. Study the meaning of the symbols and always use the equipment in the safest possible manner.

Symbol	Explanation
	Indicates the presence of high voltage (1 kV or more). Take caution to guard against electric shock.
	Indicates that the surface becomes hot, and should not be touched with bare hands.
	Before use, carefully read the instruction manual. Improper use could result in personal injury to the user and/or damage to the equipment.
	Indicates that the main switch is ON.
	Indicates that the main switch is OFF.

Warning indications

Warning indications are placed at parts where special precaution is required when handling and using the System. Always heed the warnings.

Warning indication position:	<ul style="list-style-type: none"> • Mercury burner lamp housing (U-LH100HG, U-LH100HGAPO) • Power supply unit (U-RFL-T) • ND filters (U-25ND6, U-25ND25, U-25ND50) 	[Warning against high temperature] 
		[Warning against high voltage] 

1 Getting Ready

1. This manual pertains only to the reflected fluorescence system. Before using this system together with the BX2 microscope and associated options, make sure that you have carefully read and understood their manuals, and understand how the system should be operated together.
2. The reflected fluorescence system is composed of precision instruments. Handle it with care and avoid subjecting it to sudden or severe impact.
3. Do not use the system where it is subjected to direct sunlight, high temperature and humidity, dust or vibrations.
4. To allow heat from the unit to dissipate well, reserve a distance of at least 10 cm between the lamp housing and power supply unit.
5. The power cord can also be used to cut the power supply in case of emergency. To make this possible, the power supply unit should be installed so that the power cord connector (on the rear of the power supply unit) or the power outlet is easily accessible for unplugging in case of emergency.

2 Maintenance and Storage

1. To clean the lenses and other glass components, simply blow dirty away using a commercially available blower and wipe gently using a piece of cleaning paper (or clean gauze).
If a lens is stained with fingerprints or oil smudges, wipe it gauze slightly moistened with commercially available absolute alcohol.
▲ Since the absolute alcohol is highly flammable, it must be handled carefully.
Be sure to keep it away from open flames or potential sources of electrical sparks — for example, electrical equipment that is being switched on or off.
Also remember to always use it only in a well-ventilated room.
2. With any part of the system other than glass components gets dirty, do not use organic solvents but wipe it with a clean cloth. If the part is extremely dirty, use a lint-free, soft cloth slightly moistened with a diluted neutral detergent.
3. Do not disassemble any part of the system. This could result in malfunctions or reduced performance.
4. The mercury burner has a service life period of 300 hours (USH-103OL, HBO103W/2). When the hour counter on the power supply unit indicates this value, set the main switch to “○” (OFF) and wait for more than 10 minutes before replacing the mercury burner (Page 33). Unlike electric bulbs, the mercury burner seals high-pressure gas inside. If it continues to be used after the service life has expired, the glass tube may eventually explode due to accumulated distortion.
5. When not using the microscope, be sure set the main switch to “○” (OFF). After confirming that the lamp housing has cooled down sufficiently, cover the microscope with the dust cover for storage.
6. When disposing of the microscope, check the regulations and rules of your local government and be sure to observe them.

3 Caution

If the system is used in a manner not specified by this manual, the safety of the user may be imperiled. In addition, the system equipment may also be damaged. Always use the system as outlined in this instruction manual.

The following symbols are used to set off text in this instruction manual.

- ▲ : Indicates that failure to follow the instructions in the warning could result in bodily harm to the user and/or damage to equipment (including objects in the vicinity of the equipment).
- ★ : Indicates that failure to follow the instructions could result in damage to equipment.
- ◎ : Indicates commentary (for ease of operation and maintenance).

I. REFLECTED FLUORESCENCE OBSERVATION

I NOMENCLATURE

Reflected Illuminator	BX-URA2	100 W Mercury Apo Lamp Housing	U-LH100HGAPO
Fluorescence Illuminator	BX-RFA	100 W Mercury Lamp Housing	U-LH100HG

Note The diagram shows the BX-RFA. Parts marked * are not provided on the BX-URA2.

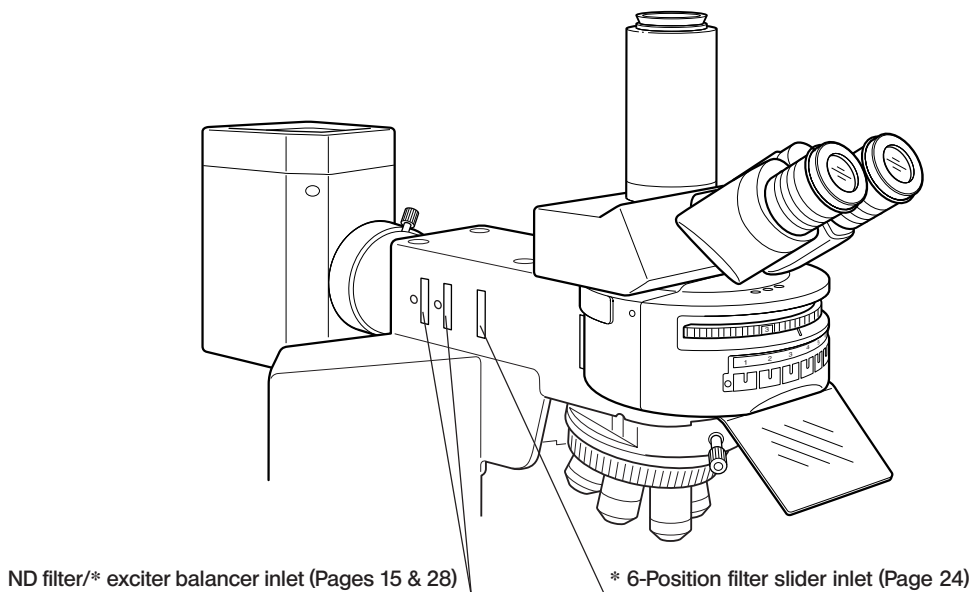
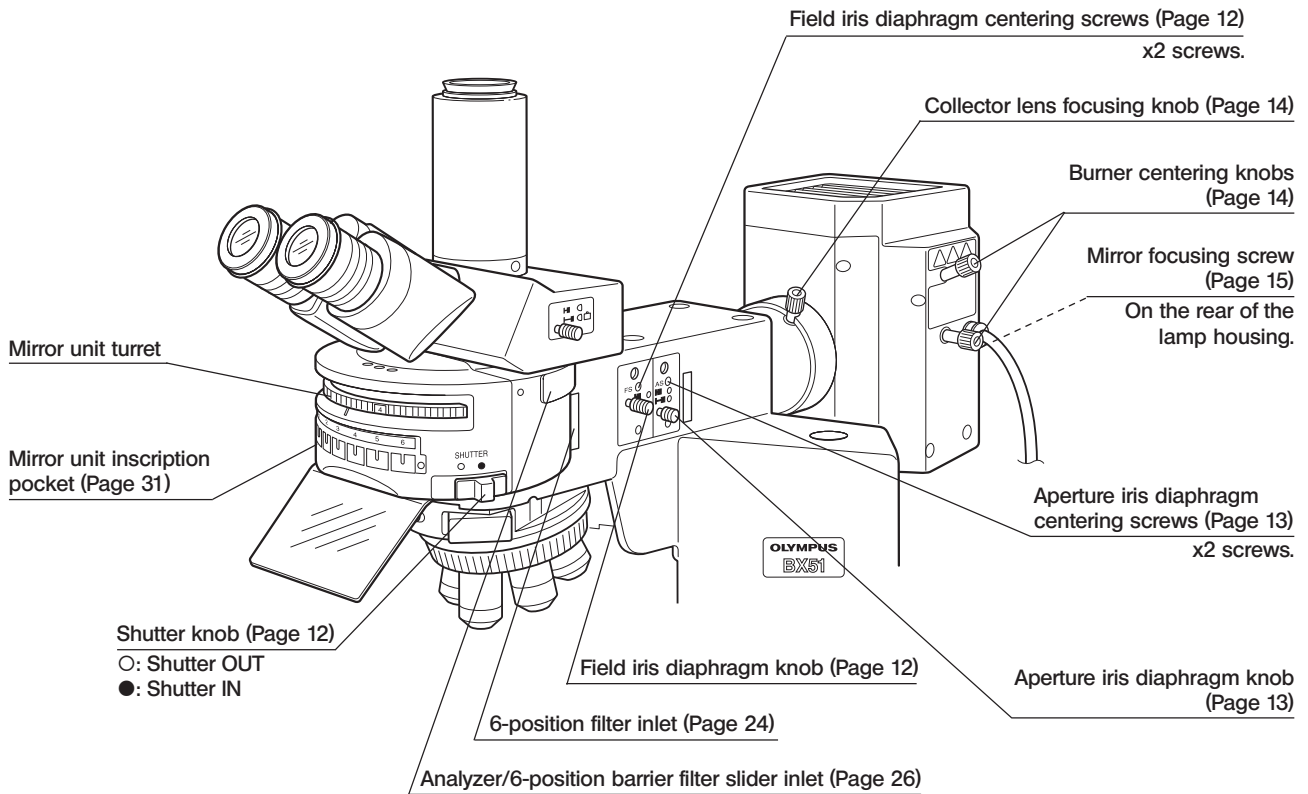

**Fluorescence Mirror Units
U-MWU2, etc., total 24 models**

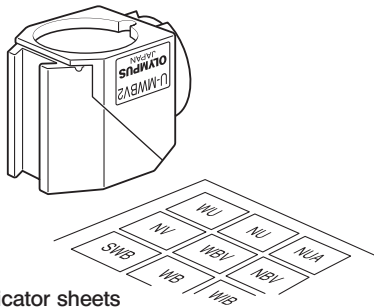

Indicator sheets

- ◎ Up to six fluorescence mirror units can be mounted on the BX-RFA or BX-URA2.
- ★ Each filter unit includes a dichroic mirror, barrier filter and excitation filter that have been combined according to the excitation method. It is basically not recommended to open a fluorescence mirror unit.
- ◎ It is recommended that you use the U-MF2 dummy filter unit (which does not contain a filter) when making your original fluorescence unit. (Page 32) Blank indicator sheets provided with the illuminator can be used to write the names of original fluorescence mirror units.

**Power Supply Unit
U-RFL-T**

◎ For details, see the instruction manual provided with the U-RFL-T.

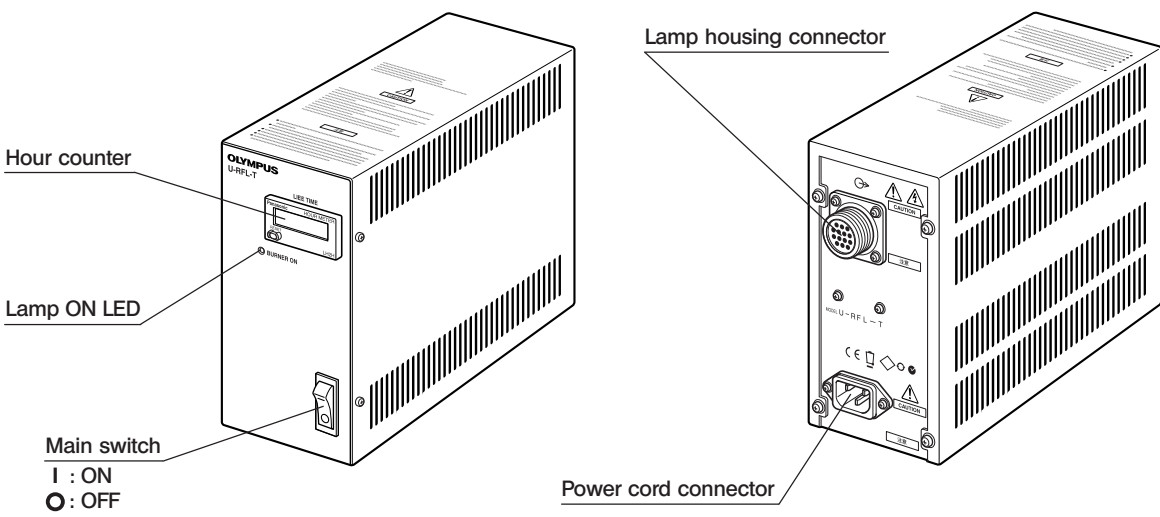

**ND Filters
U-25ND6-2, U-25ND25-2, U-25ND50-2**

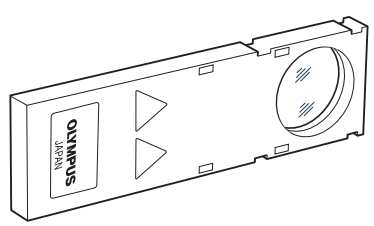

**Centering Target
U-CST**

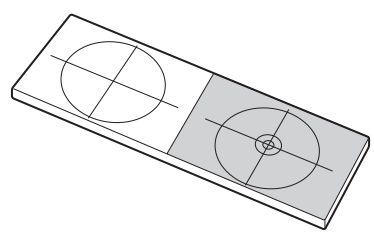

2 REFLECTED FLUORESCENCE OBSERVATION PROCEDURE

© If you need simultaneous observation of reflected fluorescence observation with the phase contrast observation or transmitted light Nomarski Differential Interference Contrast (DIC) observation, please read Chapter 4, "SIMULTANEOUS FLUORESCENCE OBSERVATION". (Page 16)

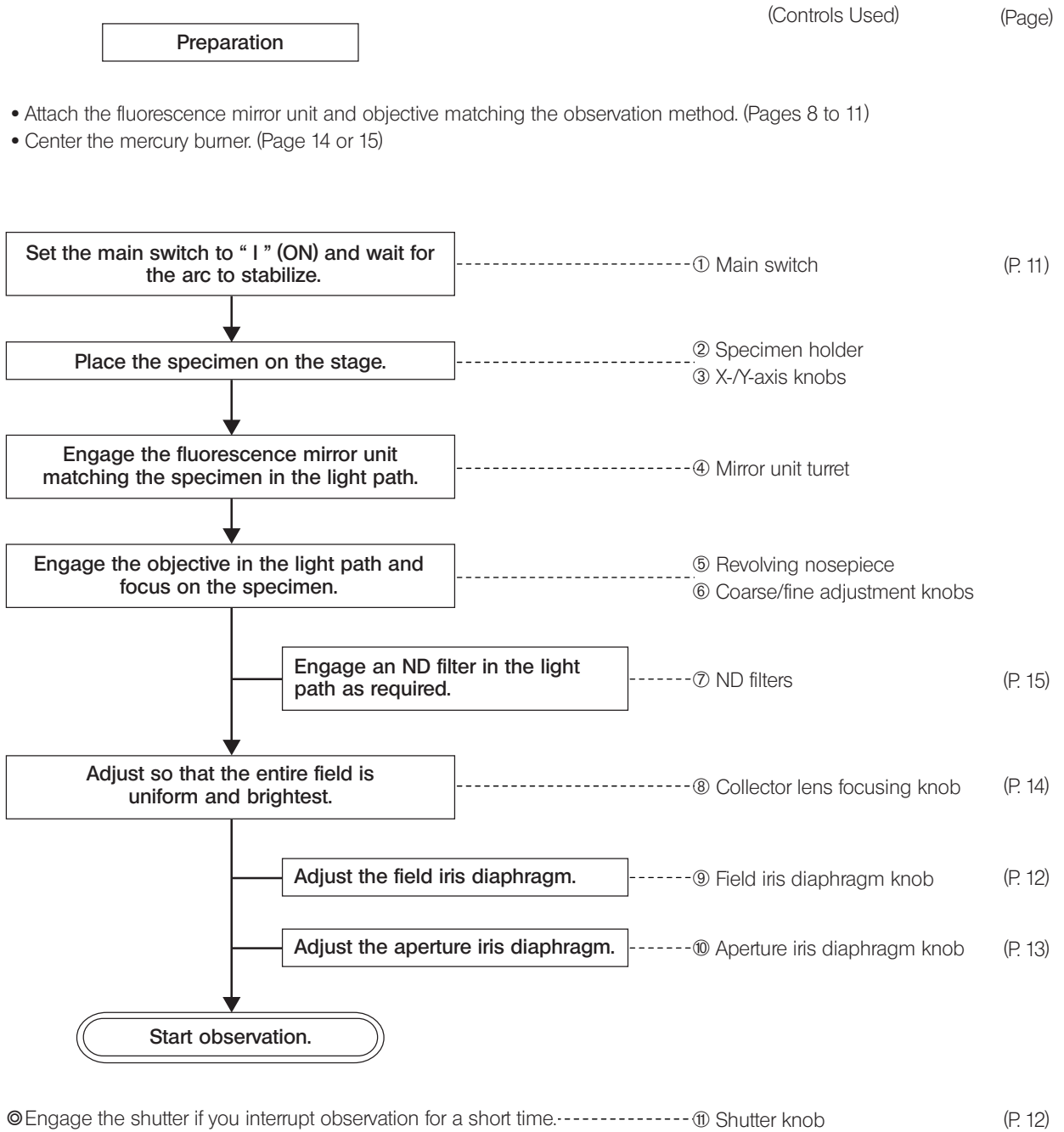

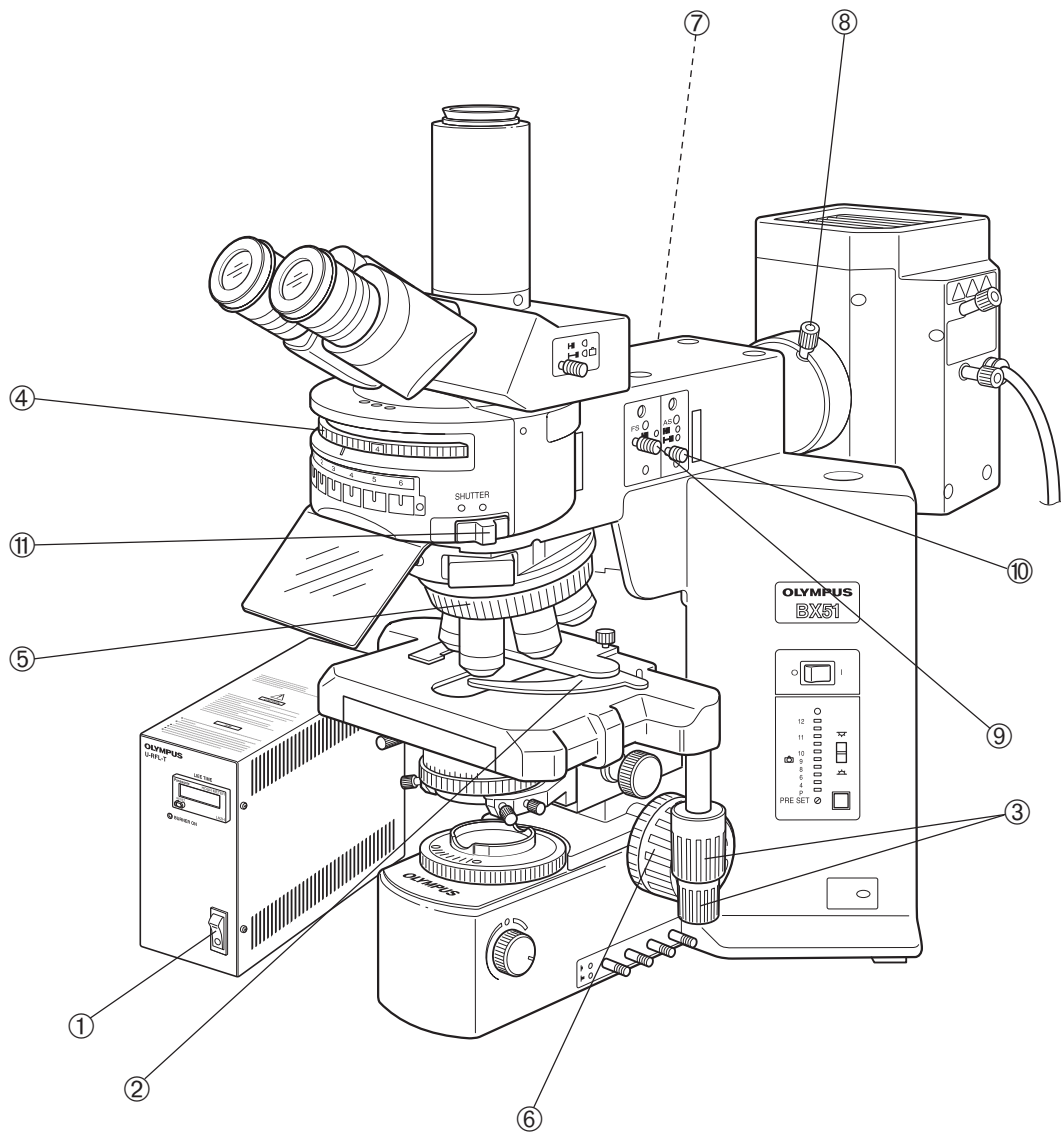

© Make a photocopy of the observation procedure pages and post it near your microscope.

3 USING THE CONTROLS

1 General Precautions for Observation

1. Make sure that the power cord and connecting cables are plugged in securely.
2. If you perform only transmitted light phase contrast or transmitted light DIC observations, leave one cube position on the turret empty. This allows for transmission of white light.
The turret must always be set to one of the click position. If it is deviated from a click position, the cover may be deformed by heat.
3. Enlarge the field iris diaphragm so it just circumscribes the field of view. If decentered, center it using the Allen screwdriver.
4. Always use immersion for oil immersion objectives.
5. If you use an objective with correction collar such as the UPlanSApo40X, UPlanFLN60X, UPlanApo40X or PlanApo40X, you can correct variations in cover glass thickness by adjusting the correction collar.

Correction procedure

If the cover glass thickness is known, match the correction collar to the cover glass thickness using the collar scale provided. If the thickness is not known, turn the collection collar and adjust the fine adjustment knob to where the image is as sharp as possible.

6. Engage the shutter if you interrupt observation for a short time.
(Turning the mercury burner ON and OFF repeatedly will significantly shorten the life span of the burner)
7. Color fading of specimens
This system features high excitation light intensity to ensure bright observation of dark fluorescence specimens. In consequence, after long period of observations using high-power objectives, the colors of specimens will fade quicker than usual, causing the view (contrast) of fluorescent images to deteriorate.
In such a case, slightly reduce the excitation light intensity to slow color fading down and improve the fluorescence images.
To reduce the excitation light intensity, use ND filters or aperture iris diaphragm as far as the observation is not affected or use the shutter to limit the exposure of specimen to more than necessary light.
Commercially-marketed color fading protection agent (DABCO, etc.) can also delay fading of specimen colors. The use of fading protection agent is recommended especially when you perform high-magnification observations frequently.

★ Remember that the fading protection agents cannot be used with certain kinds of specimens.

2 Selecting the Fluorescence Mirror Unit

Select the fluorescence mirror unit which matches the fluorochrome in use.

★ Never mount or use the U-MBF3 brightfield mirror unit together with a with a mirror unit for fluorescence. The U-MBF3 brightness is excessive and injury to the eyes could occur. If this type of mirror unit is to be used together with a mirror unit for fluorescence, use the U-MBFL3 mirror unit equipped with a built-in ND filter or add a 3% ND filter to the U-MBF3.

◎ Use according to the excitation wavelength:

Evident has prepared some sets of fluorescence mirror unit combined with appropriate filters which are variable depending on wavelengths.

The wide-band (W) set is normally used. There may be cases, however, where superwide-band (SW) or Narrow-band (N) sets are recommendable.

- | | | |
|--|---|---|
| ① Extremely weak fluorescence brightness (B- and G-excitation only): | → | Use the super-wide band (SW).
◎ With the SWB, strong autofluorescence may reduce image contrast. |
| ② Specimens emitting strong autofluorescence: | → | Use the narrow band (N).
◎ The fluorescence bright is somewhat reduced. |

Dichroic Mirror and Filter Configurations of Fluorescence Mirror Units

Excitation Method	Mirror Unit	Dichroic Mirror	Excitation Filter	Barrier Filter	Fluorochromes
U	U-MWU2	DM400	BP330-385	BA420	<ul style="list-style-type: none"> Autofluorescence observation DAPI: DNA staining Hoechst 33258, 33342: Chromosome
	U-MNU2		BP360-370		
V	U-MNV2	DM455	BP400-410	BA455	<ul style="list-style-type: none"> Catecholamine Serotonin Tetracycline: Bones, teeth
BV	U-MWBV2	DM455	BP400-440	BA475	<ul style="list-style-type: none"> Quinacrine, quinacrine mustard: Chromosome Thioflavine S: Lymphocyte Acriflavine: Nucleic acid ECFP
	U-MNBV2		BP420-440		
B	U-MWB2	DM500	BP460-490	BA520IF	<ul style="list-style-type: none"> FITC: Fluorescent antibody Acridine orange: DNA, RNA Auramine: Tubercle bacillus EGFP, S65T, RSGFP
	U-MNB2		BP470-490		
	U-MSWB2		BP420-480		
IB	U-MWIB3	DM505	BP460-495	BA510IF	
	U-MNIB3		BP470-495		
G	U-MWG2	DM570	BP510-550	BA590	<ul style="list-style-type: none"> Rhodamine, TRITC: Florescent antibody Propidium iodide: DNA RFP
	U-MNG2		BP530-550		
	U-MSWG2		BP480-550		
IG	U-MWIG3	DM570	BP530-550	BA575IF	
IY	U-MWIY2	DM600	BP545-580	BA610IF	Texas Red: Fluorescent antibody

Color Separation Filter Combinations

U	U-MNUA2	DM400	BP360-370	BA420-460	For observing only the U-excitation stain, when using U-excitation stain together with FITC.
IB	U-MWIBA3	DM505	BP460-495	BA510-550	For observing only the B-excitation stain, when using B-excitation stain with TRITC or Texas Red.
	U-MNIBA3		BP470-495		
G	U-MWIGA3	DM570	BP530-550	BA575-625	For observing only the G-excitation stain, when using G-excitation stain together with Cy5.
	U-MNIGA3		BP540-550		

Mirror Unit Name Meaning

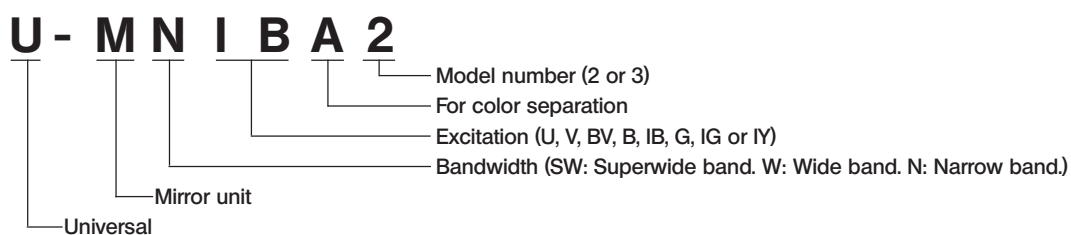

Exclusively for Fluorescent Proteins

Excitation Method	Mirror Unit	Dichroic Mirror	Excitation Filter	Barrier Filter	Fluorochromes
CFP	U-MCFPHQ	DM450HQ	BP425-445HQ	BA460-510HQ	For ECFP
GFP	U-MGFPHQ	DM485HQ	BP460-480HQ	BA495-540HQ	For EGFP
YFP	U-MYFPHQ	DM505HQ	BP490-500HQ	BA515-560HQ	For EYFP
RFP	U-MRFPHQ	DM565HQ	BP535-555HQ	BA570-625HQ	For RFP

Mirror Unit Name Meaning

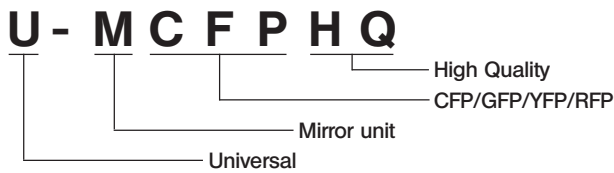

3 Objectives for Various Observation Modes

UIS2 Series

Objective	Reflected light fluorescence	Phase contrast difference	Transmitted light DIC
UPlanSApo 4X	○	-	○
10X 2	○	-	○
20X	○	-	○
20X O	○	-	○
40X 2	○	-	○
60X W	○	-	○
60X O	○	-	○
100X O	○	-	○
PlanApoN 60X O	○*	-	○
UPlanFLN 4X	○	-	-
10X 2	○	○**	○
20X	○	○**	○
40X	○	○**	○
40X O	○	-	○
60X	○	-	-
60X OI	○	○**	○
100X O2	○	○**	○
100X OI2	○	-	○

○ : Recommended combination.

○* : Slightly inferior in U-excitation.

- : Not usable, or applicable objective is not available.

○** : A phase contrast (Ph) objective is necessary for phase contrast observation.

UIS Series

Objective	Reflected light fluorescence		Phase contrast difference	Transmitted light DIC	
	U, V, BV	B, IB, G, IY			
UPlanApo	4X	○	○	-	-
	10X	○	○	○**	○
	10X O	○	○	-	○
	10X W	○	○	-	-
	20X	○	○	○**	○
	20X O3	○	○	-	○
	40X	○	○	-	○
	40X OI3	○	○	○**	○
	60X	○	○	-	-
	60X W3	○	○	-	○
	100X OI3	○	○	○**	○
PlanApo	40X	-	○	-	-
	60X O3	○	○	○**	○
	100X O3	-	○	-	-
UPlanFl	4X	○*	○*	-	-
	10X	○*	○*	○**	○
	20X	○*	○*	○**	○
	40X	○*	○*	○**	○
	60X OI3	○	○	○**	○
	100X O, OI3	○	○	○**	○
UApo	20X 3/340	○	○	-	○
	20X W3/340	○	○	-	○
	40X 3/340	○	○	-	○
	40X OI 3/340	○	○	-	○
	40X W3/340	○	○	-	○

○ : Recommended combination.

○* : Usable, but image be dark depending on NA.

- : Not usable, or applicable objective is not available.

○** : A phase contrast (Ph) objective is necessary for phase contrast observation. The Ph objective is not available for the UPlanFl100XOI3.

4 Turning the Power Supply Unit On

Set the main switch to "I" (ON). The arc will stabilize in 5 to 10 minutes after ignition.

Ⓢ The discharge type mercury burner may not be ignited from the beginning on rare occasions due to its characteristics. In this case, set the main switch to "○" (OFF), wait for 5 to 10 seconds, then set it again to "I" (ON).

★ **To extend the mercury burner life, do not turn the mercury burner off for 2 hours after ignition.**

★ **The mercury burner cannot be reignited until the mercury vapor has cooled down and liquefied. Before re-igniting a mercury burner, wait for about 10 minutes after the last time it was turned off.**

Ⓢ For the sake of safety, the power supply to the lamp housing is shut down if the lamp housing is opened while the burner is on. If this happens, set the main switch to "○" (OFF), wait for more than 10 minutes, then set it again to "I" (ON). Do not open the lamp housing until it has cooled down enough.

★ **To reset the hour counter, hold its reset button till "0.0" is displayed.**

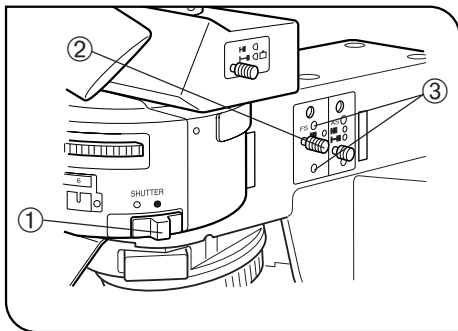

Fig. 1

5 Centering the Field Iris Diaphragm (Fig. 1)

1. Close the light path by sliding the shutter knob ① to position marked ●.
2. Engage the B or IB mirror unit in the light path by rotating the turret.
(If these mirror units are not available, engage another fluorescence mirror unit in the light path.)
3. Open the light path by sliding the shutter knob to position marked ○.
4. Engage the 10X objective in the light path, place the specimen on the stage and bring the image into approximate focus.
5. Pull out the field iris diaphragm knob ② to minimize the field iris diameter.
6. Fit the Allen wrench provided with the microscope frame in the two field iris centering screws ③ and adjust so that the iris image comes at the center of the field of view.
7. While pushing in the field iris diaphragm knob ②, enlarge the field iris diaphragm until the field iris image inscribes the field of view. If eccentricity is found after this, try centering again.
8. Enlarge the iris diaphragm until the iris image becomes almost the same size as (i.e. circumscribes) the field of view.

Effects of Field Iris Diaphragm

The field iris diaphragm restricts the diameter of the beam of light entering the objective and thus excludes extraneous light, improving image contrast. The field iris diaphragm also functions to prevent color fading of fluorescent light in other part than the observed region.

To exclude extra light, set the field iris diaphragm knob ② on the fluorescence illuminator according to the objective power, so that the image of the field iris diaphragm just circumscribes the field of view.

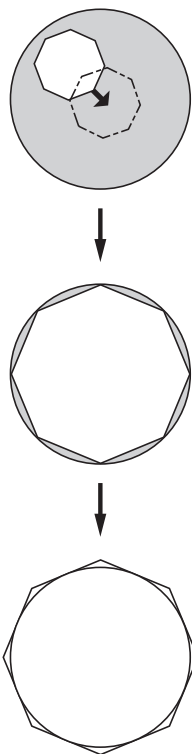

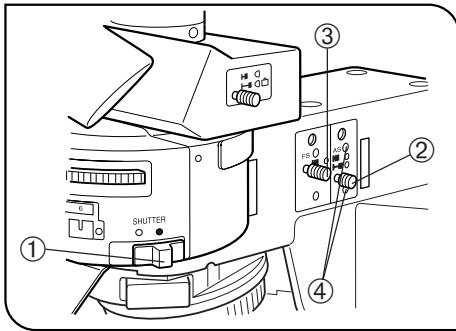

Fig. 2

6 Centering the Aperture Iris Diaphragm (Fig. 2)

1. Close the light path by sliding the shutter knob ① to position marked ●.
2. Engage the B or IB mirror unit in the light path by rotating the turret.
(If these mirror units are not available, engage another fluorescence mirror unit in the light path.)
3. Engage the 10X objective in the light path and lace the U-CST centering target on the stage.
4. Open the light path by sliding the shutter knob to position marked O.
5. Move the white surface with crosslines of the U-CST until the crosslines are overlaid on the center of field.
6. Turn the revolving nosepiece to engage the empty place (the objective cap should be removed) in the light path.
7. Pull out the aperture iris diaphragm knob ② to minimize the aperture iris diameter.
8. Pull out the field iris diaphragm knob ③ to minimize the field iris diaphragm. Now the aperture iris image should be visible on the U-CST.
9. Fit the Allen wrench in the two aperture iris centering screws ④ and adjust so that the aperture iris image coincides with the crosslines.

Effects of Aperture Iris Diaphragm

The aperture iris diaphragm helps adjust the brightness of the observed image and improve the contrast.

To execute normal fluorescence observation, enlarge the aperture iris diaphragm by pushing in the aperture iris diaphragm knob ②.

Ⓞ If specimen colors tend to fade due to too high excitation light, first use ND filters to reduce the brightness, and decrease the aperture iris diaphragm if the ND filters are not enough.

Do not decrease the aperture iris diaphragm too much. Do not use it as a substitute to the shutter.

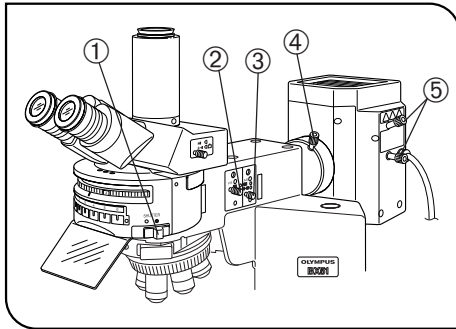
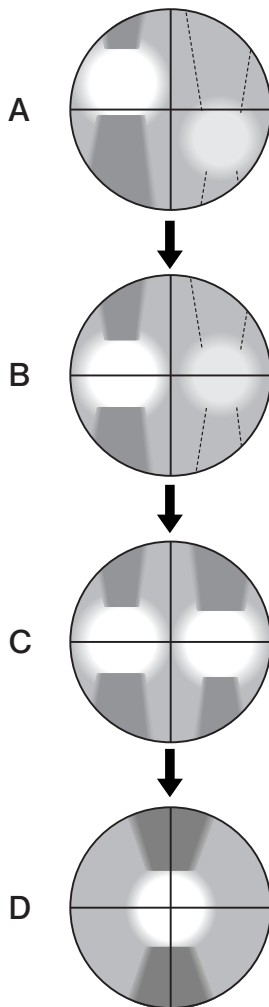

Fig. 3



7 Centering the Mercury Burner

☉Set the main switch to "I" (ON) and wait for 5 to 10 minutes until the arc stabilizes before proceeding to the mercury burner centering.

1. Close the light path by sliding the shutter knob ① to position marked ●.
2. Engage the B or IB mirror unit in the light path by rotating the turret.
(If these mirror units are not available, engage another fluorescence mirror unit in the light path. Also note that, when using a U-excitation fluorescence mirror unit, be sure to observe the specimen through a UV cut plate.)
3. Engage the 10X objective in the light path, place the U-CST centering target on the stage, and adjust the centering of the center of crosslines on white surface of the U-CST with respect to the center of field of view.
4. Turn the revolving nosepiece to engage the empty position (the objective cap should be removed) in the light path.
5. Pull out the field iris diaphragm knob ② (to minimize it) and push in the aperture iris diaphragm knob ③ (to enlarge it).
6. Open the shutter by setting shutter knob ① to position marked ○.
7. Project the arc image on the U-CST by turning the collector lens focusing knob ④. (A)

If the arc image is not protected, adjust the burner centering knobs ⑤.

8. ring the arc image on the center of the left (or right) half of the field by turning the burner centering knobs ⑤. (B)
9. Focus on the mirror arc image by adjusting the mirror focus screw ⑥ (Fig 4) on the rear of the lamp housing using the Allen screwdriver. (C)
10. Overlay the arc image with the mirror arc image by turning the burner centering knobs ⑤. (D)

☉During observation, adjust the collector lens focusing knob ④ so that the observed field is uniform.

☉Hereafter, the mercury burner centering need not be adjusted until the next time the mercury burner is replaced.

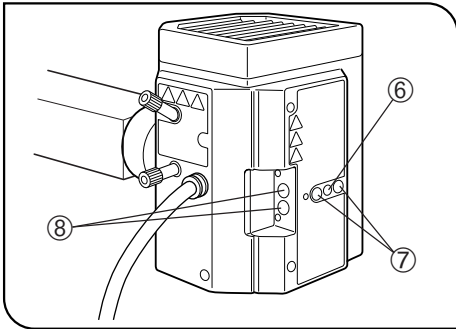

Fig. 4

Precise Centering of the Mirror Arc Image

⊙ The mirror arc image position has been adjusted and fixed at the factory. Perform the centering of the mirror arc image after completing the centering of the mercury burner and only when you want to make your adjustments very strict and precise.

Note that, once this adjustment has been executed, the mirror can never be returned to the same status as the factory shipment status.

1. Using a pair of tweezers, etc., peel off the two blind seals ⑦ from the rear of the lamp housing.
2. Loosen the screws below the seals using the Allen screwdriver. The mirror is unclamped when these two screws are loosened.
3. Then peel off another couple of blind seals ⑧. This exposes the mirror arc image centering holes.
4. Adjust the centering of the mirror arc image using the Allen screwdriver in these holes.

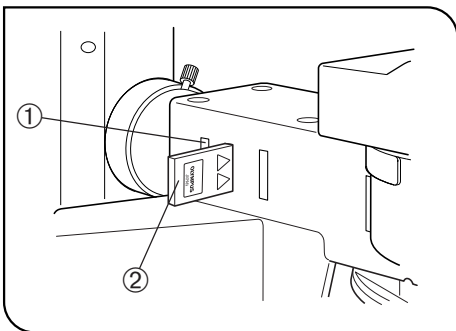

Fig. 5

8 Mounting the ND Filters

⊙ Specimen color fading can be delayed by reducing the excitation light intensity with ND filters. Use the ND filters as far as they do not hinder observations.

- As necessary, up to two ND filters (with ND of 6 and 25) may be individually inserted into filter insertion positions ① and/or ②. Insert the ND filters (U-25ND6-2 and/or U-25ND25-2, U-25ND50-2) with the marked side facing toward the observer.

The ND filters must be inserted in the correct orientation. Otherwise, the ND filters may be damaged.

- As you insert a filter, you will hear two clicks. At the first, the filter is at the at an empty position, and at the second click the filter enters the light path.

⚠ **Note that the metallic filter frame will be very hot if you leave the filter inserted for a long time while the mercury burner is on.**

Do not leave the filter insertion positions in other positions than the click positions for a long period of time.

4 SIMULTANEOUS FLUORESCENCE OBSERVATIONS

Ⓞ By properly combining equipment, this system can be used in transmitted light brightfield observation, transmitted phase contrast observation and transmitted light DIC observation in addition to the reflected fluorescence observation. With specimens that fade rapidly, fading can be minimized by initially using transmitted light phase contrast or transmitted light DIC observation for positioning. Reflected fluorescence observation can also be executed simultaneously with phase contrast or DIC observation, making it easy to tell which portion of the specimen is fluorescing.

1 Simultaneous Reflected Fluorescence and Phase Contrast Observations

The phase contrast observation requires a phase contrast condenser (U-PCD2) or a universal condenser (U-UCD8) and a Ph objective.

1. Engage a dummy mirror unit (or an empty position on the turret) in the light path.
2. Rotate the phase contrast turret to show the same number as the Ph number shown on the objective.
3. Adjust the optical axis between the ring slit and phase plate by centering them.
4. Engage the mirror unit corresponding to the desired excitation into the light path and open the shutter.
5. Adjust the transmitted light for the best balance of fluorescence and phase contrast brightness, and you are ready for observation.

Ⓞ Use ND filters or the light intensity control lever on the microscope base to adjust the transmitted light intensity.

Ⓞ For details on using phase contrast observation, refer to the instruction manual provided with the phase contrast condenser or universal condenser.

2 Simultaneous Reflected Fluorescence and Transmitted Light Nomarski Differential Interference Contrast (DIC) Observations

The transmitted light Nomarski DIC observation requires the following accessories; 1) universal condenser (U-UCD8); 2) transmitted light DIC slider (U-DICT, U-DICTS, U-DICTHR or U-DICTHC); 2) analyzer (U-AN or U-AN360-3); 6- or 7-position revolving nosepiece for DIC (U-D6RE or U-D7RE).

Ⓞ In order for reflected fluorescence to be effective in the simultaneous observation, insert the analyzer (U-AN or U-AN360-3) into the analyzer inlet slot above the dichroic mirror on the illuminator.

Do not insert the U-ANT analyzer in the transmitted light DIC slider, for this will dim the fluorescence observation image and cause the analyzer to be burnt.

1. Engage the dummy mirror unit (or an empty position on the turret) in the light path.
2. Adjust the polarizer on the universal condenser to the "crossed Nicol" (complete extinction) status.
3. Insert the transmitted light DIC slider into the position provided on the nosepiece.
4. Rotate the turret on the universal condenser to select the Nomarski prism matching the objective to be used for observation.
5. Engage the objective to be used in the light path.
6. Place the specimen on the stage and focus on the specimen.
7. Adjust the field iris diaphragm of the transmitted light illumination unit (built into the microscope base) and the aperture iris diaphragm of the universal condenser.
8. Turn the prism movement knob on the transmitted light DIC slider to adjust contrast of the DIC image.
9. Engage the mirror unit corresponding to the desired excitation in the light path and open the shutter.
10. Adjust the transmitted light for optimum fluorescence and DIC image brightness.

Ⓞ For details on the transmitted light DIC observation, refer to the instruction manual provided with the U-UCD8 transmitted light universal condenser.

Notes

Ⓞ We recommend the use of the highly wear-resistant U-ANH analyzer-slider instead of the U-AN analyzer when you are frequently switching between reflected fluorescence observation and transmitted light Nomarski DIC observation and need to use both observations simultaneously.

Ⓞ However, if you are frequently switching between reflected fluorescence observation and transmitted light Nomarski DIC observation but you do not need to use both simultaneously, then it will be more convenient for you to use the M-DICT3 DIC mirror unit instead of an analyzer (U-AN or U-ANH). This facilitates the switching operation because the analyzer simultaneously enters the light path when the fluorescence mirror unit is switched to the DIC mirror unit.

5 TROUBLESHOOTING GUIDE

Under certain conditions, performance of the unit may be adversely affected by factors other than defects. If problems occur, please review the following list and take remedial action as needed. If you cannot solve the problem after checking the entire list, please contact your local Evident representative for assistance.

Problem	Cause	Remedy	Page
1. Optical System			
a) Burner is ON but light cannot be seen from eyepiece or is dark.	Shutter is closed.	Open the shutter.	4
	ND filter is engaged in light path.	Remove ND filter as required.	15
	Fluorescence mirror unit is not correctly engaged in light path.	Engage it correctly.	4
	Aperture and field iris diaphragms are not fully enlarged.	Fully enlarge aperture iris diaphragm and enlarge field iris diaphragm until it circumscribes field of view.	13
	Fluorescence mirror unit does not match specimen.	Use fluorescence mirror unit matching specimen.	9/10
b) Image is low quality, not sharp or poor in contrast.	Dirt/dust on objective or filter.	Clean thoroughly.	3
	Aperture and field iris diaphragms are not properly enlarged.	Fully enlarge aperture iris diaphragm and enlarge field iris diaphragm until it circumscribes field of view.	12/13
	Fluorescence mirror unit does not match specimen.	Use fluorescence mirror unit matching specimen.	9/10
c) Field of view is obscured or not evenly illuminated	Objective is not correctly engaged in light path.	Make sure that revolving nosepiece clicks properly into place.	—
	Fluorescence mirror unit is not correctly engaged in light path.	Engage fluorescence mirror unit correctly in light path.	—
	Field iris diaphragm is set too small.	Fully enlarge field iris diaphragm.	12
	ND slider is not stopped at click position.	Make sure that ND slider clicks properly into place.	15
	Mercury burner is not centered or focusing is defective.	Center mercury burner or perform focusing adjustment.	14
d) Field contains dark, spot-like areas.	Dirt or dust on burner or on burner side of collector lens.	Clean them.	3
2. Electrical System			
a) Main switch cannot turn system ON.	Power cord is not connected properly.	Connect firmly.	—
b) Even when the main switch is set to "I" (ON), the mercury burner does not light.	Connectors are not connected properly.	Connect firmly.	—
	Mercury burner is not attached.	Attach mercury burner.	33
	Safety device in lamp housing is active.	Set up the lamp socket correctly.	33
	Auto ignition is malfunctioning.	Set main switch of power supply unit to "O" (OFF) then "I" (ON) again. (OFF/ON can be repeated.)	11
c) Mercury burner flickers or is dark.	It is soon after ignition.	Leave for 10 minutes or more after ignition.	11
	Burner life has expired.	If hour counter indicates 300 hours (USH-103OL, HBO103W/2), replace mercury burner.	33
	Burner is deviated from optical axis.	Center mercury burner.	14

6 SPECTRAL CHARACTERISTICS OF FILTERS

1. U-excitation (Wide band)

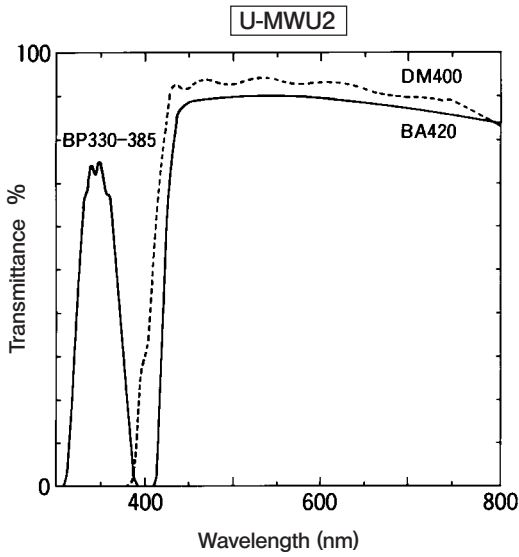

2. U-excitation (Narrow band)

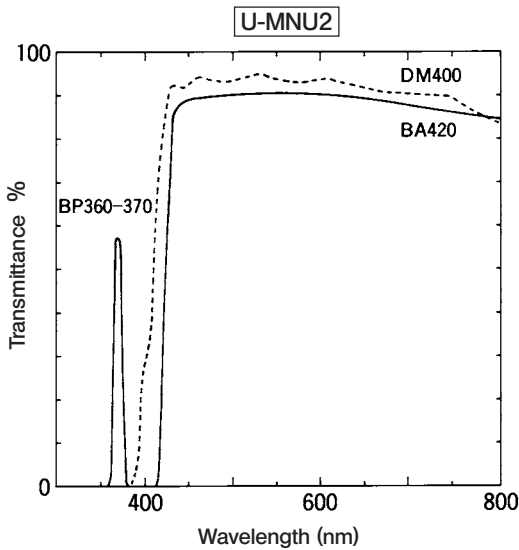

3. V-excitation (Narrow band)

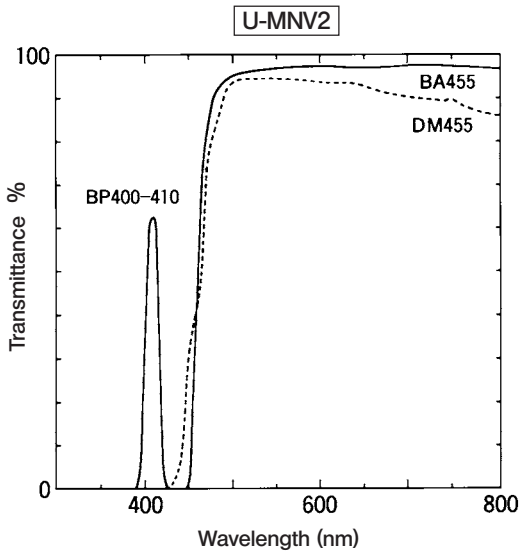

4. BV-excitation (Wide band)

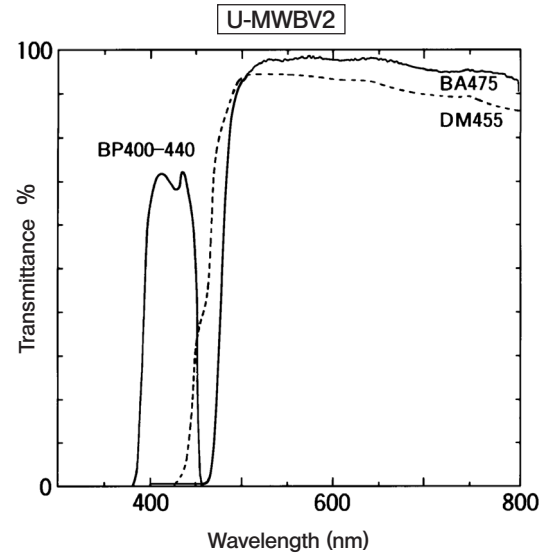

5. BV-excitation (Narrow band)

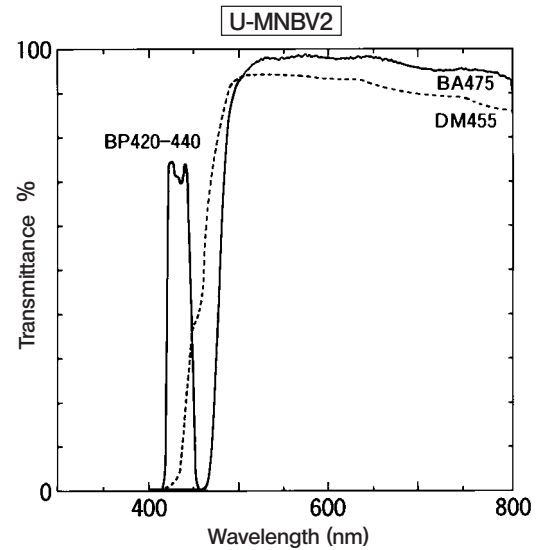

6. B-excitation (Wide band)

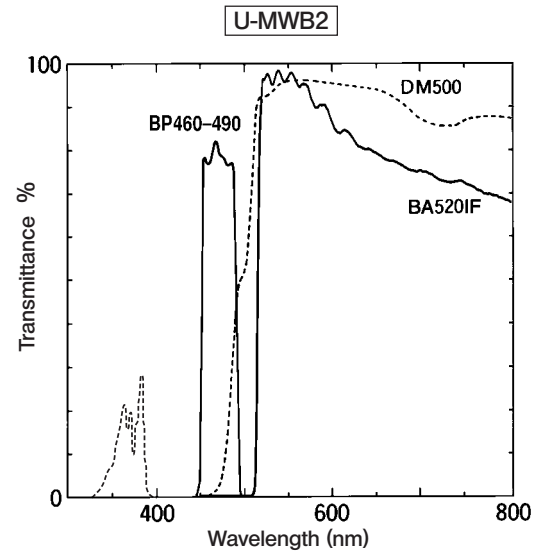

7. B-excitation (Narrow band)

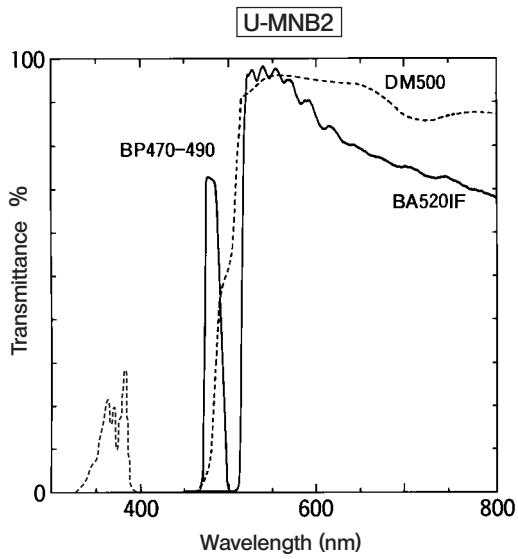

8. B-excitation (Superwide band)

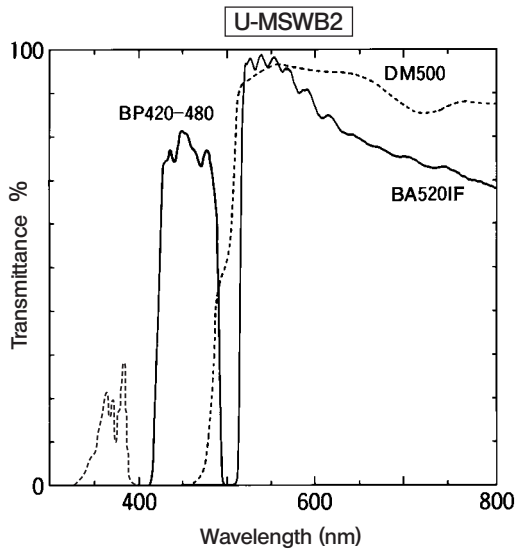

9. IB-excitation (Wide band)

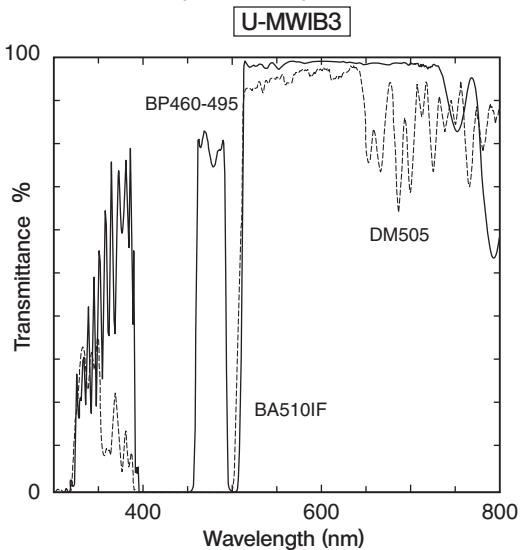

10. IB-excitation (Narrow band)

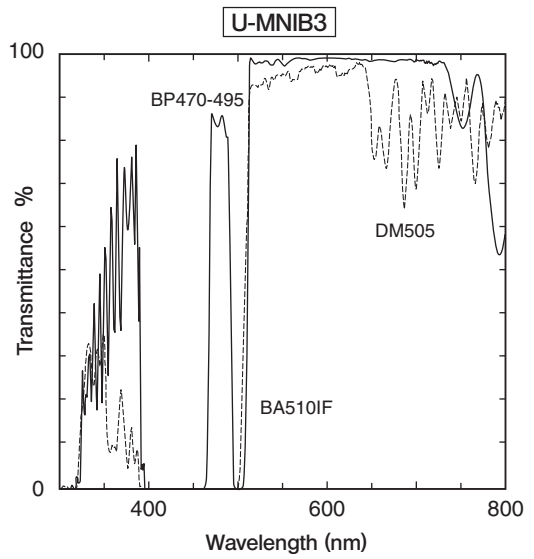

11. G-excitation (Wide band)

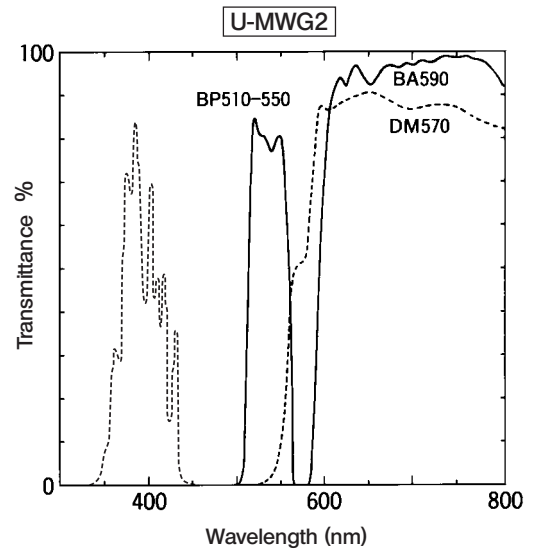

12. G-excitation (Narrow band)

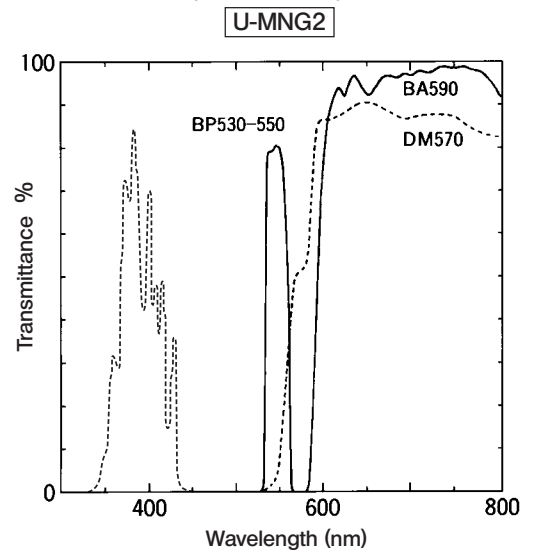

13. G-excitation (Superwide band)

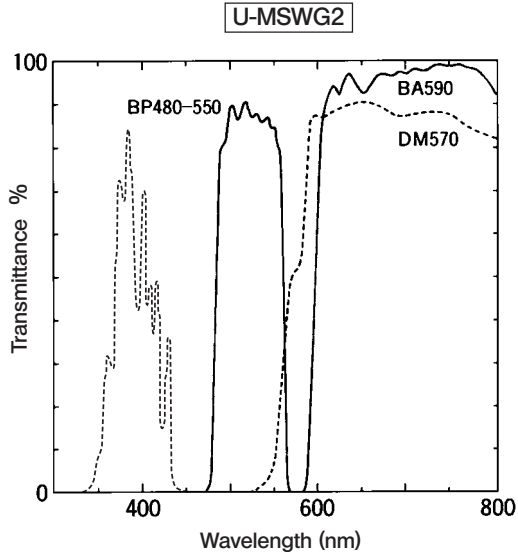

14. IG-excitation (Wide band)

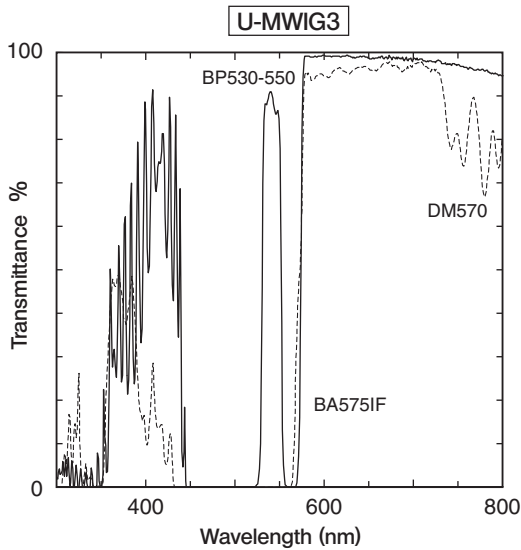

15. IY-excitation (Wide band)

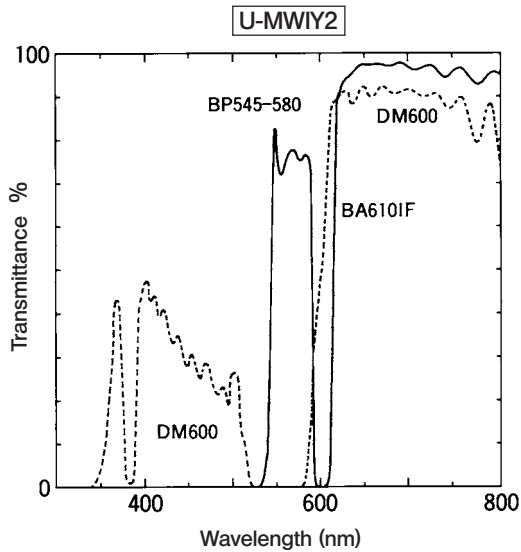

16. U-excitation, color separation (Narrow band)

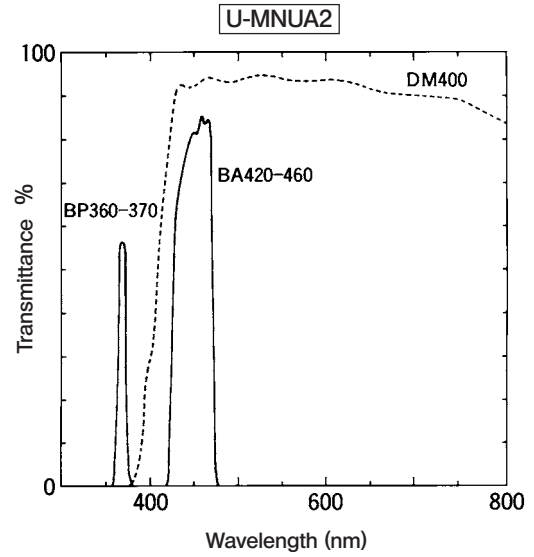

17. IB-excitation, color separation (Wide band)

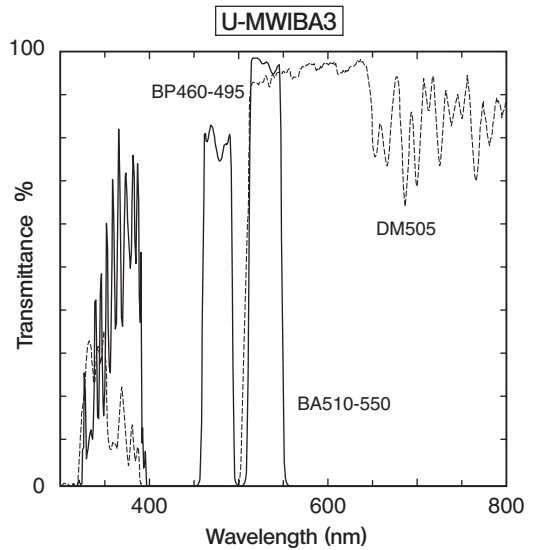

18. IB-excitation, color separation (Narrow band)

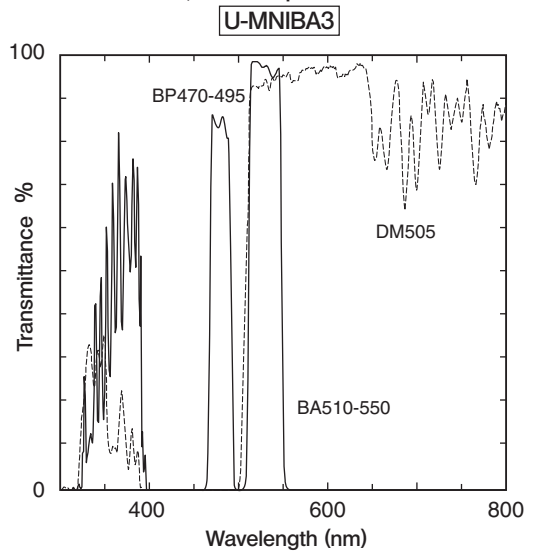

19. G-excitation for color separation (Wide band)

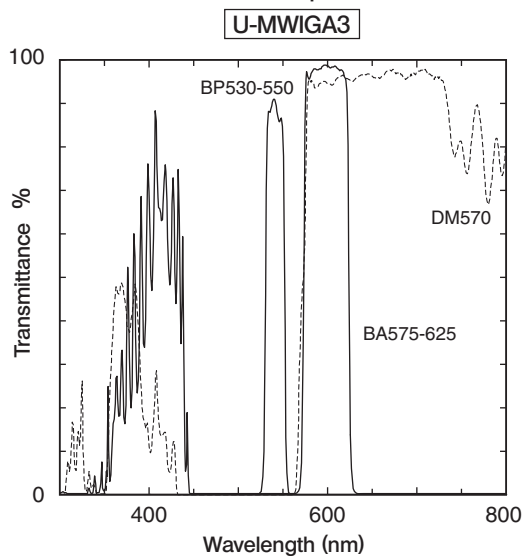

20. G-excitation for color separation (Narrow band)

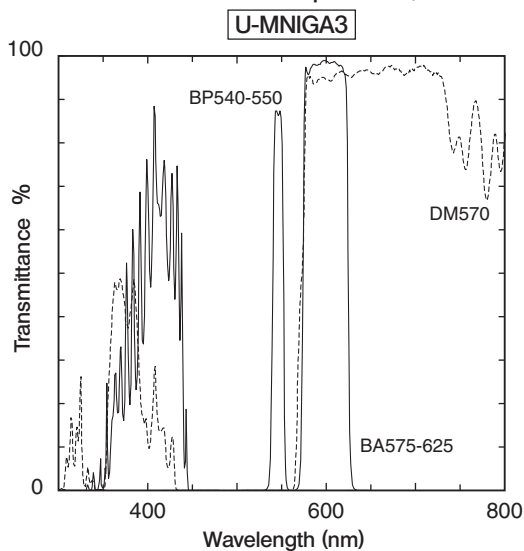

21. For cyan fluorescent protein (CFP)

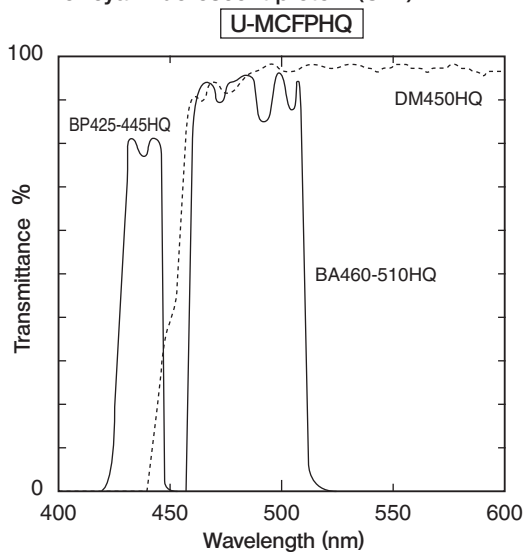

22. For green fluorescent protein (GFP)

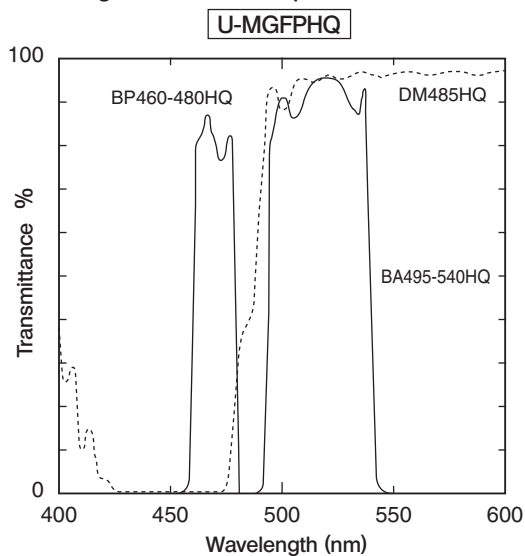

23. For yellow fluorescent protein (YFP)

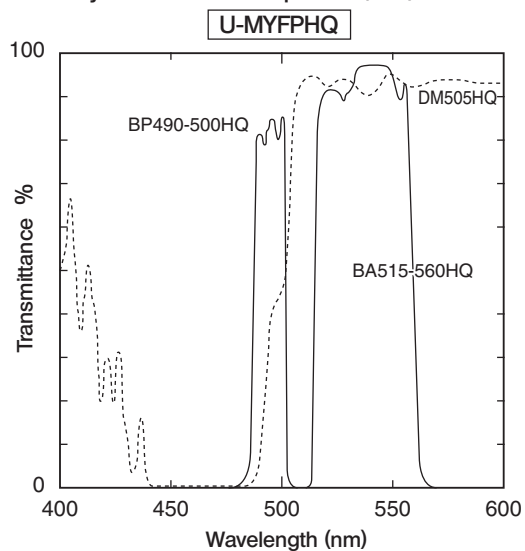

24. For red fluorescent protein (RFP)

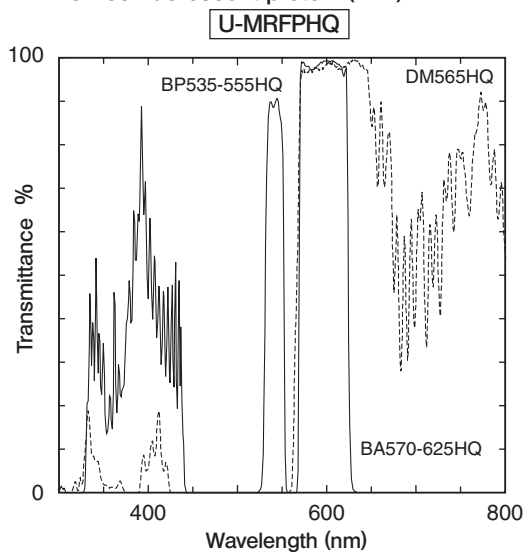

Typical Example of Emission Spectrum of Ultra-High-Vacuum Mercury Burner Spectrum

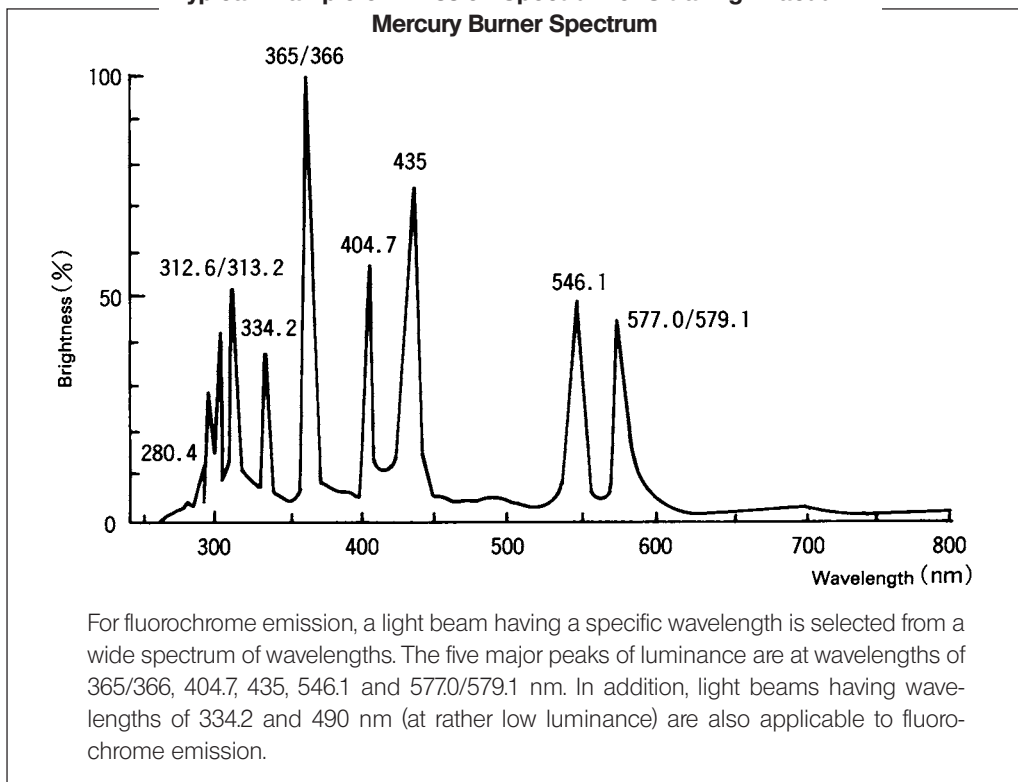

7 SPECIFICATIONS

Item	Specification			
Vertical illuminators	Reflected Illuminator BX-URA2	Fluorescence Illuminator BX-RFA		
	<ul style="list-style-type: none"> • UIS2/UIS (Universal Infinity System) optical system (featuring infinity correction) • Magnification: 1X (Superwide field: NA 26.5) • Observation switching: Mirror unit turret carrying max. 6 mirror units. • Aperture iris diaphragm and field iris diaphragm (Both centerable) Detachable with the BX-RFA. • Shutter provided. 			
	<ul style="list-style-type: none"> • Slider inlet <table border="0" style="width: 100%;"> <tr> <td style="width: 50%; vertical-align: top;"> <ul style="list-style-type: none"> ① Analyzer/6-position barrier filter slider ② Polarizer/6-position filter slider ③ ND filters </td> <td style="width: 50%; vertical-align: top;"> <ul style="list-style-type: none"> ① Analyzer/6-position barrier filter slider ② 6-position filter slider ③ ND filters ④ 6-position filter slider </td> </tr> </table>		<ul style="list-style-type: none"> ① Analyzer/6-position barrier filter slider ② Polarizer/6-position filter slider ③ ND filters 	<ul style="list-style-type: none"> ① Analyzer/6-position barrier filter slider ② 6-position filter slider ③ ND filters ④ 6-position filter slider
	<ul style="list-style-type: none"> ① Analyzer/6-position barrier filter slider ② Polarizer/6-position filter slider ③ ND filters 	<ul style="list-style-type: none"> ① Analyzer/6-position barrier filter slider ② 6-position filter slider ③ ND filters ④ 6-position filter slider 		
	<ul style="list-style-type: none"> • Available observation modes <table border="0" style="width: 100%;"> <tr> <td style="width: 50%; vertical-align: top;"> <ul style="list-style-type: none"> ① Reflected fluorescence ② Reflected fluorescence + Transmitted DIC ③ Reflected fluorescence + Phase contrast ④ Reflected light brightfield ⑤ Reflected light darkfield ⑥ Reflected light DIC ⑦ Reflected light simplified polarization ⑧ Transmitted light </td> <td style="width: 50%; vertical-align: top;"> <ul style="list-style-type: none"> ① Reflected fluorescence ② Reflected fluorescence + Transmitted DIC ③ Reflected fluorescence + Phase contrast ④ Transmitted light </td> </tr> </table>		<ul style="list-style-type: none"> ① Reflected fluorescence ② Reflected fluorescence + Transmitted DIC ③ Reflected fluorescence + Phase contrast ④ Reflected light brightfield ⑤ Reflected light darkfield ⑥ Reflected light DIC ⑦ Reflected light simplified polarization ⑧ Transmitted light 	<ul style="list-style-type: none"> ① Reflected fluorescence ② Reflected fluorescence + Transmitted DIC ③ Reflected fluorescence + Phase contrast ④ Transmitted light
<ul style="list-style-type: none"> ① Reflected fluorescence ② Reflected fluorescence + Transmitted DIC ③ Reflected fluorescence + Phase contrast ④ Reflected light brightfield ⑤ Reflected light darkfield ⑥ Reflected light DIC ⑦ Reflected light simplified polarization ⑧ Transmitted light 	<ul style="list-style-type: none"> ① Reflected fluorescence ② Reflected fluorescence + Transmitted DIC ③ Reflected fluorescence + Phase contrast ④ Transmitted light 			
<ul style="list-style-type: none"> • Optional accessories <table border="0" style="width: 100%;"> <tr> <td style="width: 50%;"></td> <td style="width: 50%; vertical-align: top;"> <ul style="list-style-type: none"> ① Exciter/balancer ② Rectangle field stop </td> </tr> </table>			<ul style="list-style-type: none"> ① Exciter/balancer ② Rectangle field stop 	
	<ul style="list-style-type: none"> ① Exciter/balancer ② Rectangle field stop 			
Mercury lamp housing	<ul style="list-style-type: none"> • 100 W mercury lamp housing U-LH100HG • 100 W mercury apo lamp housing U-LH100HGAP0 • Mercury burner: USH-103OL (Evident) • Power supply unit U-RFL-T 			
Operating environment	<ul style="list-style-type: none"> • Indoor use. • Altitude: Max. 2000 meters • Ambient temperature: 5° to 40°C (41° to 104° F) • Maximum relative humidity: 80% for temperatures up to 31°C (88°F), decreasing linearly through 70% at 34°C (93°F), 60% at 37°C (99°F), to 50% relative humidity at 40°C (104°F). • Supply voltage fluctuations; Not to exceed ±10% of the normal voltage. • Pollution degree: 2 (in accordance with IEC60664) • Installation/Overvoltage category: II (in accordance with IEC60664) 			

8 OPTIONAL MODULES

★ The sliding performance of the U-RSL6 or U-RSL6RM filter slider may drop when it has been used for 2000 or more times of reciprocation. In this case, remove the dirt and contamination on the sliding surface. If it is expected to use the slider for more 2000 times of reciprocation or more, apply a thin layer of lubricant, such as grease on the sliding surface.

1 6-Position Filter Slider U-RSL6

© This filter slider is for use with the BX-URA2 or BX-RFA illuminator and accommodates a total of six excitation and ND filters. It is designed to prevent centering deviation between the optical axes of the excitation filters when multiple excitation mirror units are used and switched.

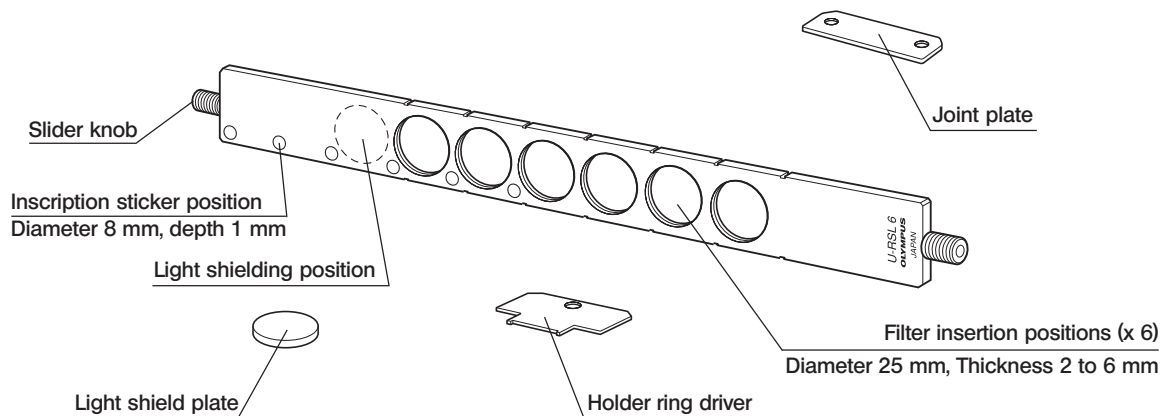

Filter Mounting Procedure

1. Remove the slider knob on the opposite end to the extremity where the slider inscription is engraved, and place the filter slider so that the surface with the slider inscription faces down.
2. Remove the filter holder rings from the filter insertion positions by turning it counterclockwise using the provided holder ring driver.

★ **The insertion orientation of the holder rings should be changed according to the thickness of the mounted filters.**

3. If the mounted filter includes an exciter filter, insert it so that the arrow inscription on the side faces down.

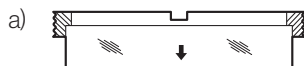

- a) Filter with thickness of 4 mm or more:
Place each filter so that it fits inside the holder ring.

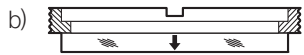

- b) Filter with thickness of 4 mm or less:
Place each filter so that it does not fit inside the holder ring.

▲ **If you perform transmitted light observation or you do not want to use a filter, mount the provided light shield plates (having the same size as the filter) in place.**

If nothing is mounted, the scattered light of reflected lighting may enter your eyes or the view in transmitted light observations will be deteriorated.

4. If it is required to attach a filter type inscription, attach a seal as described in the next section on the U-RSL6EM filter slider.
5. Insert the filter slider from the right of the 6-position filter slider inlet slot on the illuminator so that inscription "U-RSL6" comes at the deep, then attach the slider knob which has been removed in the above.

Using the Joint Plates

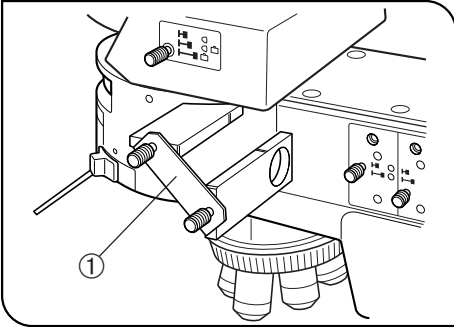

Fig. 6

NOTES

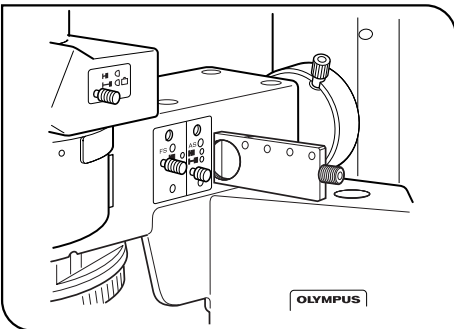

Fig. 7

The joint plates ① can be attached and locked between the slider knob and slider as shown in the figure. The joint plates should be attached on both ends of the filter slider.

By locking with the joint plates, you can switch the barrier and excitation filters together as a set.

- When inserting the 6-position filter slider in the 6-position filter slider near the rear panel, insert from the left so that the "U-RSL6" inscription comes at the deep. Otherwise, the filters will not be set in the correct positioning.
- When the 6-position filter slider near the rear panel is used, avoid using the interference type or color glass type filters. This is because the 6-position filter slider near the rear panel is one of the positions where the energy from the light source is concentrated. When an interference type or color glass type filter is mounted in it, the filter interference film may peel off or the color glass may be damaged.
- Make sure that the 6-position filter slider is set to a click position.
- For safety, insert the provided light shield plates in the unused filter positions.

2 6-Position Barrier Filter Slider U-RSL6EM

© This filter slider is for use with the BX-URA2 or BX-RFA illuminator and accommodates a total of six barrier filters.

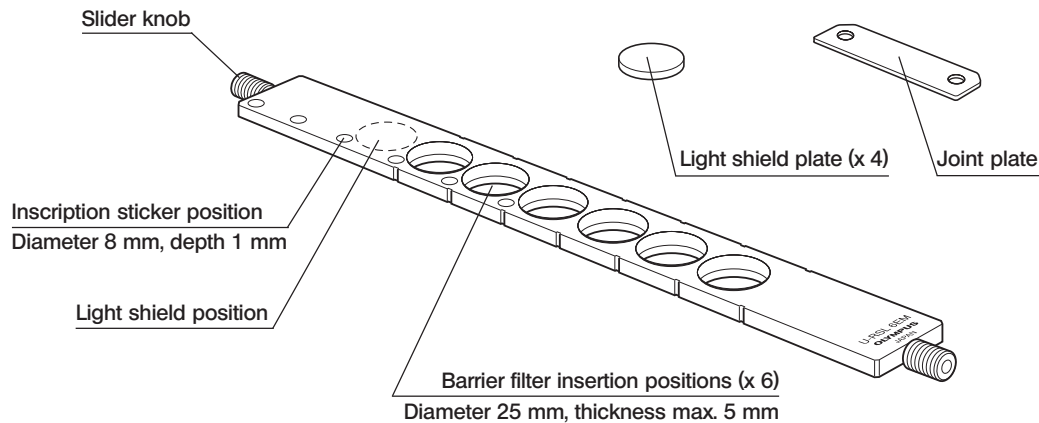

Filter Mounting Procedure

- 1 Remove the slider knob on the opposite end to the extremity where the slider inscription is engraved.
- 2 Gently place the barrier filters in filter insertion positions.
★ Insert the filters so that their arrow inscriptions on the side face downward.
3. If it is required to inscribe the type of the inserted filter, write it on a commercially available round sticker with a diameter of less than 8 mm, and attach it to the specified inscription sticker position.
★ Make sure that the sticker does not deviate from the specified circular area. Otherwise, the slide will be caught in motion.
4. Gently insert the filter slider from the right of the analyzer inlet slot on the illuminator, and attach the slider knob which has been removed in the above.
5. Use the joint plate if you want to interlock this filter slider with the U-RSL6 filter slider. (For the attaching method, see the description on the U-RSL6.)

NOTES

- Be sure to insert each filter in the specified orientation. Otherwise, the filter cannot be set in the correct positioning.
- For safety, insert the provided light shield plates in the unused filter positions.

3 Rectangle Field Stop BX-RFSS (for exclusive use with the BX-RFA)

Ⓞ When fluorescence images are recorded with the TV camera for observation or image processing, this unit projects a rectangular iris diaphragm image with size variable according to the captured image size. This helps prevent color fading of specimen due to other reasons than image capturing.

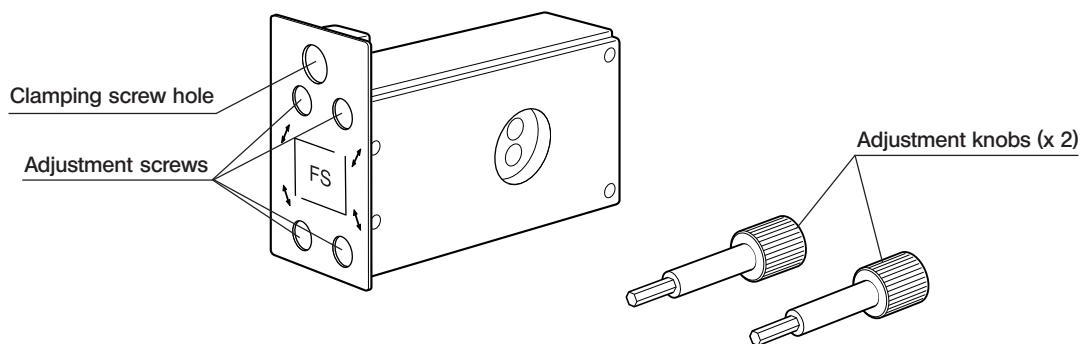

Ⓞ The adjustment knobs can be stored in the upper slots of the adjustment screws.

Installation Procedure (Fig. 8)

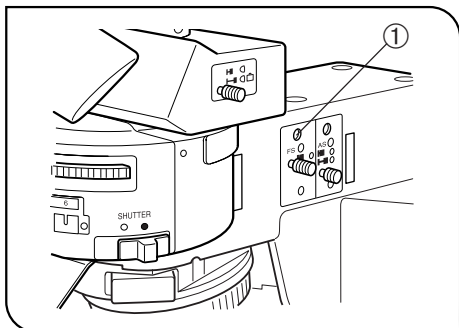

Fig. 8

1. Using the Allen screwdriver, loosen and take out the field iris diaphragm clamping screw ① of the BX-RFA.
2. Remove the field iris diaphragm by pulling it out toward you.
3. Insert the BX-RFSS rectangle field stop into the position of the field iris diaphragm, then tighten the clamping screw ①.

Operation

1. Insert the provided adjustment knobs into the two adjustment screw holes near the front panel, and move the two sides of the rectangle to the desired position by turning the knobs.
2. Insert the adjustment knobs into the two adjustment screw holes near the rear panel, and move the other two sides of the rectangle by turning the knobs.
3. After the desired shape has been obtained by moving the sides, remove the adjustment knobs.

Ⓞ Rectangle area: A rectangle which circumscribes the field with a number of 22 (the center of the rectangle should be located at the center of field). The rectangle iris diaphragm cannot be rotated.

NOTE

The BX-RFA fluorescence illuminator cannot be attached or removed while the BX-RFSS is installed. If you want to install the BX-RFA, remove the BX-RFSS temporarily.

4 Exciter Balancers U-EXBABG/EXBAUB/EXBAUG (for exclusive use with the BX-RFA)

©When an image of fluorescence by multiple excitation of U/B/G is observed with dual- or triple-band fluorescence mirror units, use the exciter balancer to select the balance between the excitation light intensities of the fluorochromes.

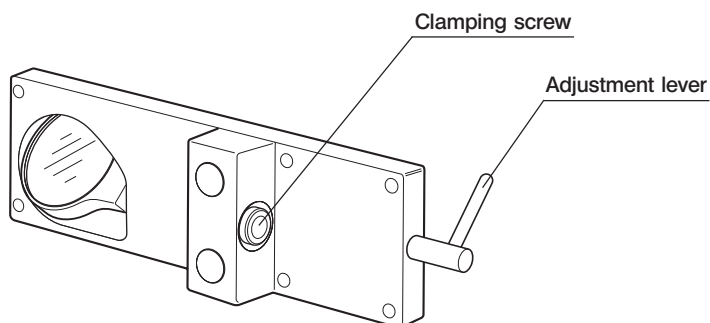

Installation Procedure (Fig. 9)

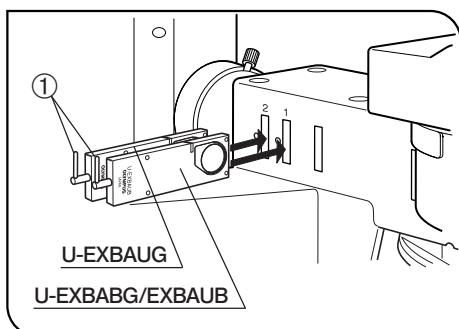

Fig. 9

1. Stand the adjustment lever ① of the exciter balancer vertically and insert it in one of the ND filter inlets with the same number as the slider on the left side of the illuminator, or into the one which is located near the illuminator rear panel.

- The insertion position is variable depending on the type of the exciter balancer.
- With any type of exciter balancer, always insert so that the clamping screw faces toward you.

2. Tighten the clamping screws using the Allen screwdriver.

Operation

Observing a Double Stained Specimen

1. Set up normal reflected fluorescence observation.
2. Mount the fluorescence mirror units for double staining and engage them in the light path.

©Evident standard products

Exciter Balancer	Fluorescence Mirror Unit	
	Fluorescence mirror units for double staining	Fluorescence mirror units for triple staining
U-EXBABG	<ul style="list-style-type: none"> •U-DM-FI/TR2 •U-DM-FI/PI2 •U-DM-FI/TX2 	<ul style="list-style-type: none"> •U-DM-DA/FI/TR2 •U-DM-DA/FI/PI2 •U-DM-DA/FI/TX2
U-EXBAUB	<ul style="list-style-type: none"> •U-DM-DA/FI2 	
U-EXBAUG	<ul style="list-style-type: none"> •U-DM-DA/TR2 •U-DM-DA/PI2 •U-DM-DATX2 	

★ Due to its own characteristics, the G-excitation has a narrower intensity control range than the U- and B-excitation. The intensity control range is also variable depending on the status of specimen and mirror units.

★ Lighting irregularities may be observed on the upper and lower edges of the field due to the rotation angles of filters and the variance in mirror units' characteristics. However, these lighting irregularities does not affect the photographed area.

3. Push in the adjustment lever of the balancer slider to be used to engage the filter in the light path.
 ◎The angle of each adjustment lever can be adjusted in the range shown below, only when the lever is pushed in.

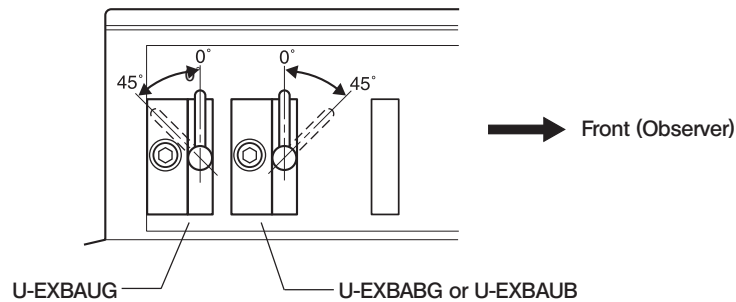

4. While conducting fluorescence observation, adjust by tilting the adjustment lever of the exciter balancer which is currently in the light path.
- With the U-EXBABG, setting the lever to 0° enhances the fluorescence of longer wavelengths (near red) and to 45° enhances the fluorescence of shorter wavelengths (near green).
 - With the U-EXBAUB, setting the lever to 0° enhances the fluorescence of shorter wavelengths (near blue) and to 45° enhances the fluorescence of longer wavelengths (near green).
 - With the U-EXBAUG, setting the lever to 0° enhances the fluorescence of longer wavelengths (near red) and to 45° enhances the fluorescence of shorter wavelengths (near blue).

Observation of Triple Stained Specimen

- ◎The operation is basically similar to the double stained specimens, but fluorescence mirror units for triple staining should be used. The exciter balancers to be used are the U-EXBAUB (front inlet) and U-EXBAUG (rear inlet).
- While conducting fluorescence observation, adjust the intensities of the three fluorescence lights by tilting the two adjustment levers.

NOTES

1. When the adjustment lever of an exciter balancer is stood vertically, flare tends to occur easily due to the repeated reflections on the filter surface. Be sure to disengage the exciter balancer from the light path when it is not used.
2. Be sure to stand the adjustment lever vertically when disengaging the filter from the light path or removing the exciter balancer. (Otherwise, damage may result.)
3. To use the ND filters while the balancer is already used, insert the ND filters in the 6-position filter inlet slot which is near the front panel (i.e. on the left).

9 ASSEMBLY

9-1 Assembly Diagram

The diagram below shows the sequence of assembly of the various modules. The numbers indicate the order of assembly. The module numbers shown in the following diagram are merely the typical examples. For the modules with which the module numbers are not given, please consult your Olympus representative or the catalogues.

★ When assembling the microscope, make sure that all parts are free of dust and dirt, and avoid scratching any parts or touching glass surfaces.

Assembly steps enclosed in ■ will be detailed on the subsequent pages.

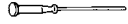
◎ All assembly operations are possible by using the Allen screwdriver () provided with the microscope.

The Allen wrench () provided with the illuminator is used only for clamping the screws inside the illuminator. (To retain the performance, have your Evident representative conduct this work.)

NOTES

- Parts marked with ★ can be attached only to the BX-URA2 universal illuminator.
- Be sure to insert the sliders in the orientations shown in the diagram. Otherwise, they cannot be fitted in click positions and engaged correctly in the light path.
- To prevent fire, install the lamp housing with the radiator fan positioned on the top and with sufficient space around the housing.

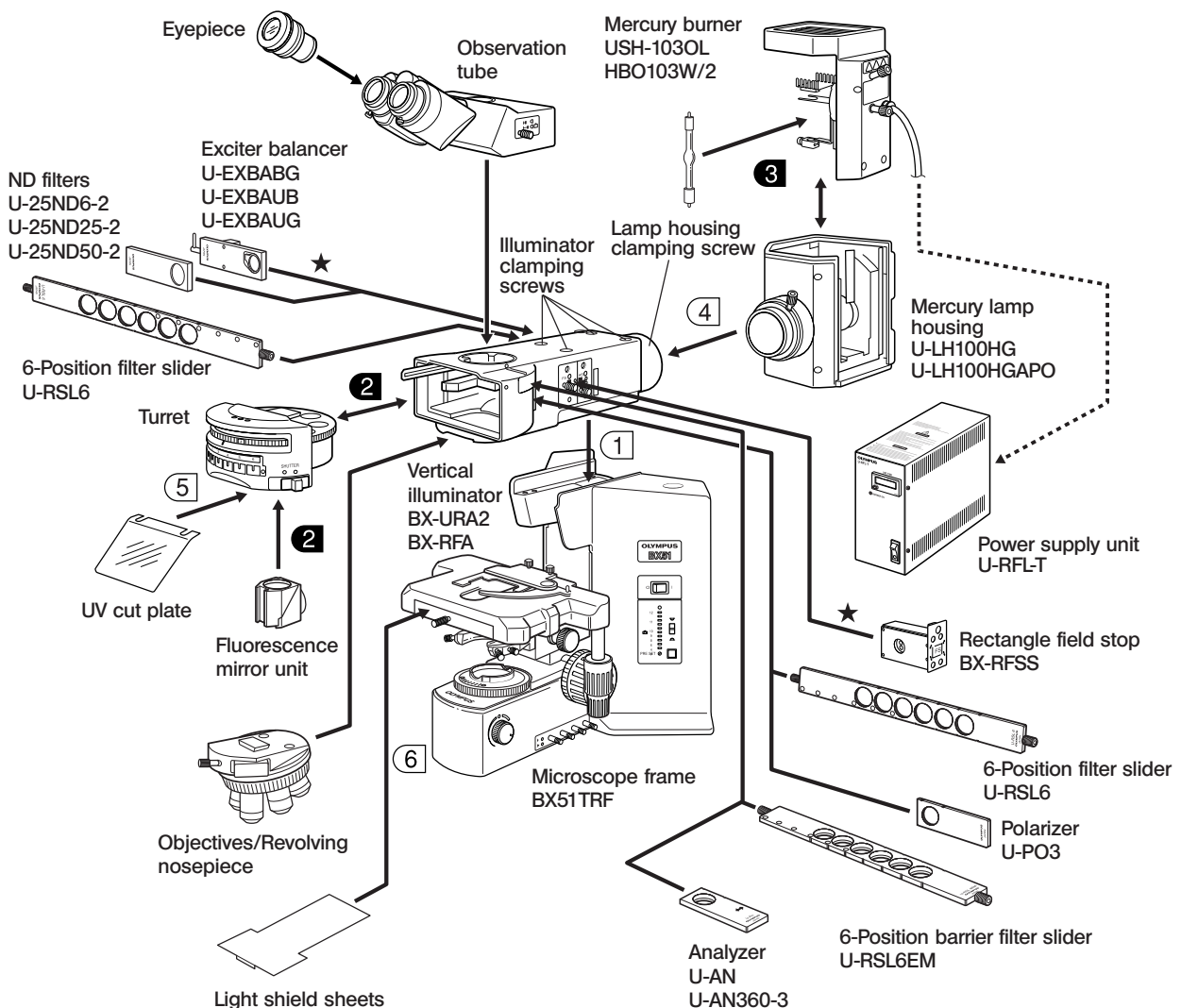

9-2 Detailed Assembly Procedures

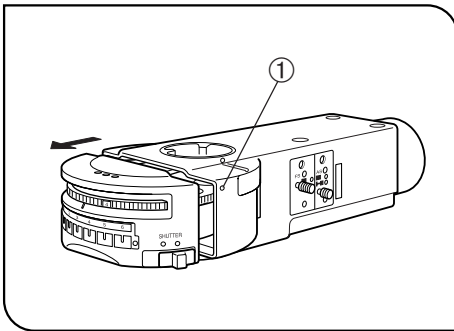

Fig. 10

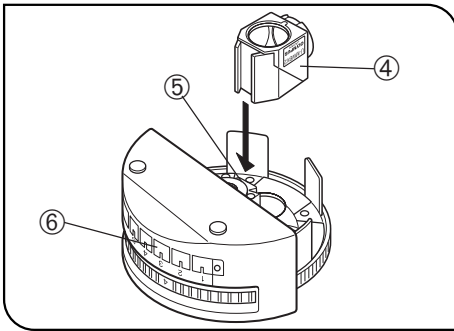
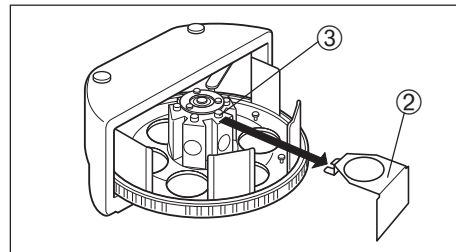

Fig. 11

2 Attaching the Fluorescence Mirror Units (Figs. 10 & 11)

1. Using the Allen screwdriver, loosen the clamping screw ① at the right side of the vertical illuminator.
2. Pull out the turret and place it upside down.
- Ⓞ Dummy mirror units ② are mounted in the mirror unit positions. Remove the dummy mirror units from the positions you want to mount mirror units by loosening the clamping screw ③ of each mirror unit using the Allen screwdriver.



3. Hold the fluorescence mirror unit ④ to be mounted so that the model name inscription on the side is upside down, align it with the mount dovetail and insert all the way into the insertion position. Tighten the clamping screw ⑤ firmly.
- ★ If the clamping screw ③ is loose, The turret will be unable to be rotated due to interference with the cover.
4. Check the mount dovetail number ⑤ and place the inscription sheet of the mounted fluorescence mirror unit into the inscription pocket ⑥ with the same number on the front of the turret.
 5. Mount other the required fluorescence mirror units by repeating the above steps for each of them.
 6. Place the turret in the original position and tighten the clamping screw ① while pushing the turret in.

Making an Optional Fluorescence Mirror Unit

◎ You can also fabricate optional fluorescence mirror units by fitting a commercially available barrier filter, excitation filter or dichroic mirror in the U-MF2 mirror unit frame.

Dimensions of Optical Parts

- Barrier filter
 - Excitation filter
 - Dichroic mirror
- } Diameter $\phi 25$ $-0.1/-0.2$ mm, max. thickness 6 mm.
26 $-0.1/-0.3$ x 38 $-0.1/-0.3$ mm, thickness 1 ± 0.05 mm

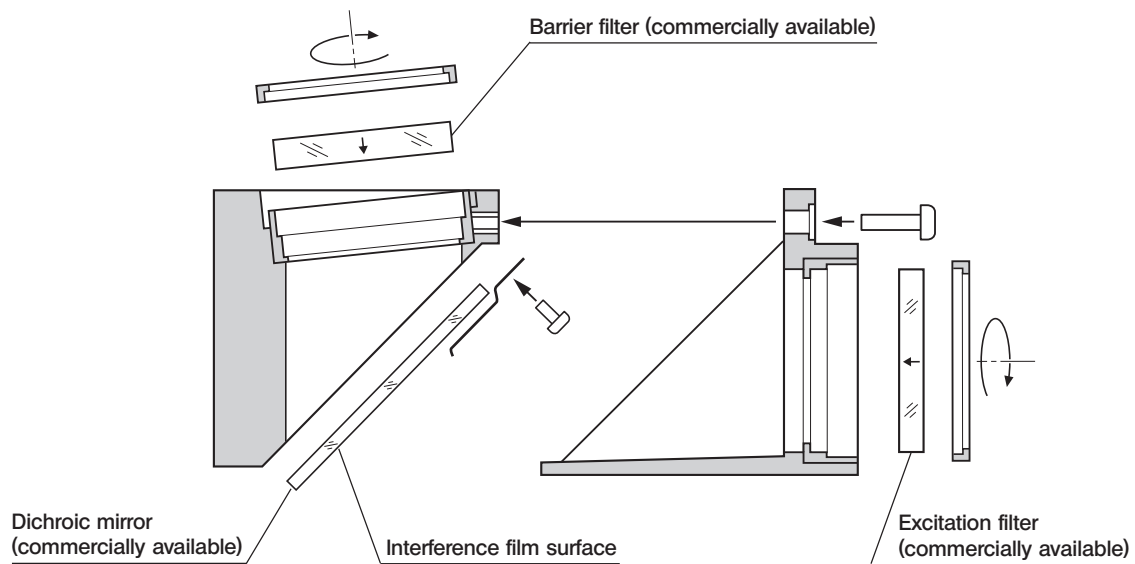

★ When replacing the dichroic mirror, take special care not to stain it with fingerprints, etc.

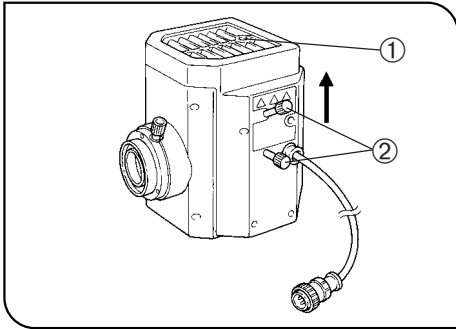

Fig. 12

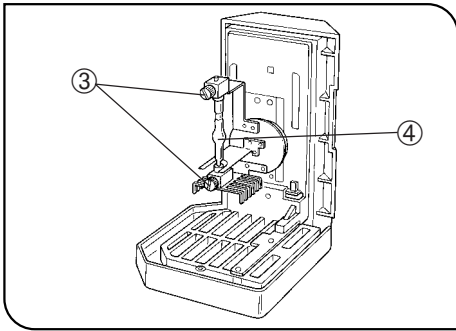

Fig. 13

3 Attaching the Mercury Burner (Figs. 12 - 15)

1. Loosen the socket clamping screw ① using the Allen screwdriver.
2. Hold the upper section of lamp housing and pull it upward to remove the socket section.

★ To prevent malfunctions, do not hold the lamp housing by the centering knobs ②.

3. Place the socket section upside down as shown in Fig. 13.

Ⓞ The lamp housing is equipped with the holder for transportation in the factory shipment condition, or with an old burner when the burner is replaced. Remove the holder or old burner by loosening the two burner holding screws ③.

4. Attach the + (positive) pole of a specified mercury burner ④ to the fixed mount on the upper side, and the - (negative) pole to the mount on the lower side.

★ Be sure to use the USH-103OL (mfd, by Evident) or HBO103W/2 (mfd. by OSRAM) burner.

▲ Be careful and avoid leaving fingerprints or contaminants on the mercury burner. Otherwise, there is a danger of explosion due to distortion of glass caused by the stains. If the burner is contaminated, clean it by wiping gently with gauze slightly moistened with absolute alcohol.

5. Attach the socket section with burner to the original position and tighten the clamping screw ①.

★ Align the external edges of the lamp housing with those on the socket section, and push the lamp housing straight downward.

Burner Service Life

USH-103OL: 300 hours

Ⓞ This value assumes light cycles composed of 2 hours of lighting and 30 minutes of extinction. Do not turn it on and off at a shorter cycle than the above, for this will shorten the service life of the burner.

▲ After replacing the burner, reset the hour counter to "0.0" as outlined above.

II. REFLECTED OBSERVATIONS (BX-URA2 Only)

1 CONFIGURATION OF REFLECTED OBSERVATION SYSTEM

The BX-URA2 universal illuminator can be used in a variety of brightfield observations, darkfield observation, DIC observation and simplified polarized observation under reflected lighting when it is used in combination with a UIS2/UIS objective for metallic specimens, the U-MBF3 brightfield mirror unit, U-MDF3 darkfield mirror unit, etc.

Ⓞ Replace the standard stage with the stage for metallurgical specimens or the specimen holder with the stage plate for easier observation.

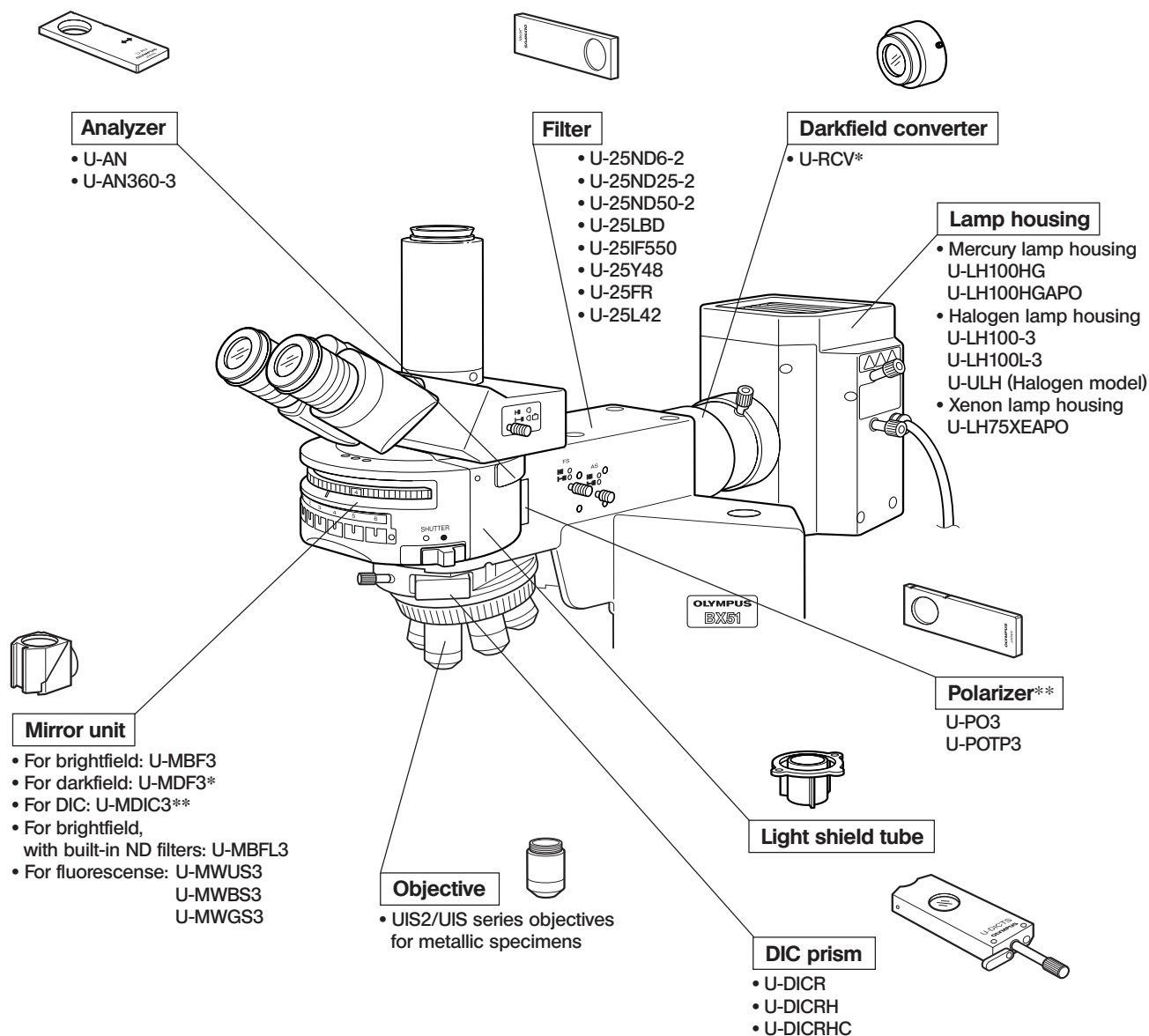

* The U-RCV darkfield converter is required when the U-MDF3 mirror unit is used.

** When the U-MDIC3 mirror unit or the U-PO3 or U-POTP3 polarizer is used, combine the U-25L42 filter to prevent polarizing optics from being deteriorated by UV rays from a high-intensity light source other than a halogen light source.

2 ASSEMBLY

© This chapter pertains only to the assembly of items which cannot be assembled in the same way as the fluorescence modules.

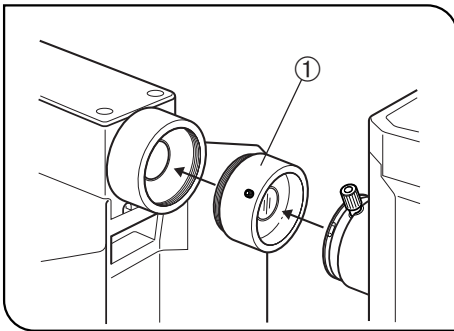

Fig. 14

1 Attaching the U-RCV Darkfield Converter (Fig. 14)

© Be sure to use this darkfield converter when the U-MDF3 mirror unit for darkfield observation is used.

- Insert the darkfield converter ① between the reflected illuminator and lamp housing.

★ With ultrawide-field observation, the ambient lighting may be insufficient with certain types of specimens.

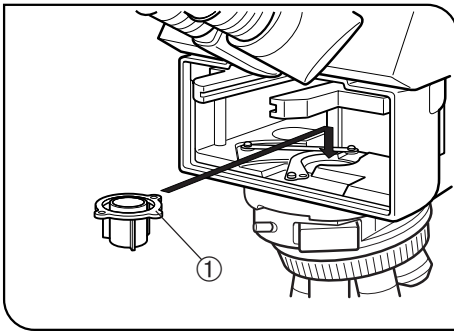

Fig. 15

2 Attaching the Light Shield Tube (Fig. 15)

© The light shield tube must be used with darkfield observation (using DF mirror unit).

1. Remove the turret.
2. Place the light shield tube in the reflected illuminator so that the positioning collar ① on the tube comes on the right.

3 FIELD IRIS AND APERTURE IRIS DIAPHRAGM ADJUSTMENTS

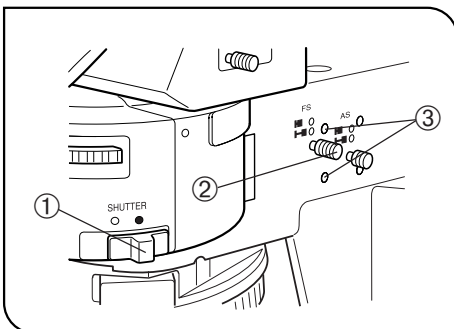
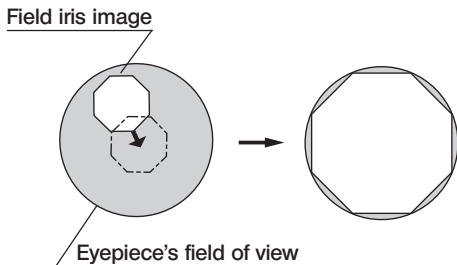

Fig. 16

1 Centering the Field Iris Diaphragm (Fig. 16)

1. Rotate the turret to engage the mirror unit (BF) in the light path, then open the shutter ①.
2. Rotate the revolving nosepiece to engage the 10X objective, then place the specimen on the stage and bring the image into approximate focus.
3. Pull out the field iris diaphragm knob ② on the reflected illuminator to where the diameter of the diaphragm is at its smallest.



4. Fit the Allen screwdrivers provided with the microscope frame into the two field iris diaphragm centering screws ③ and adjust them so that the field iris image of the diaphragm is centered on the field of view.
5. To check centering, enlarge the diaphragm by pushing in the field iris diaphragm knob ② until the diaphragm image touches the perimeter of the field of view. If the image is not centered precisely, center it again.
6. Further enlarge the iris diaphragm until its image just circumscribes the field of view.

Effects of Field Iris Diaphragm

● Reflected light brightfield, DIC and simplified polarized light observations:

To obtain good image contrast, adjust the diameter of the illuminating beam in accordance with the objective in use.

Using the field iris diaphragm knob ② on the reflected illuminator, adjust the diaphragm so that the field of view is circumscribed by the field iris diaphragm in order to exclude stray light.

● Reflected light darkfield observation:

Always keep the field iris diaphragm knob ② pushed in to leave the diaphragm open.

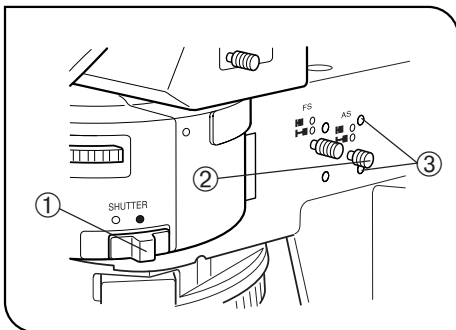

Fig. 17

2 Centering the Aperture Iris Diaphragm (Fig. 17)

1. Engage the mirror unit (BF) in the light path by turning the turret, then open the shutter ①.
2. Rotate the revolving nosepiece to engage the 10X objective, then place a highly flat specimen such as a mirror on the stage, and bring the image into approximate focus.
3. Remove the eyepiece. While looking into the eyepiece sleeves, pull out the aperture iris diaphragm knob ② so that the aperture iris image can be seen in the field.
4. Fit the Allen screwdrivers provided with the microscope frame into the two aperture iris diaphragm centering screws ③ and adjust them so that the aperture iris image of the diaphragm is centered on the field of view.

Effects of Aperture Iris Diaphragm

● Reflected light brightfield observation:

In general, favorable observation is possible by setting the aperture iris of the illumination system to 70% to 80% of the N.A. of the objective.

★ The effects of aperture iris diaphragm cannot be obtained with 150X and 250X objectives.

● Reflected light darkfield observation:

Always keep the aperture iris diaphragm knob ② pushed in to leave the diaphragm open.

◎ With certain specimens, smaller aperture may sometimes offer images with better contrast and smaller flare. Please also try such a setting.

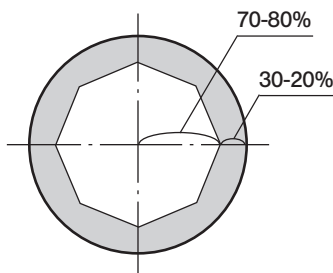

4 OBSERVATIONS

4-1 Reflected Light Brightfield/Darkfield Observations

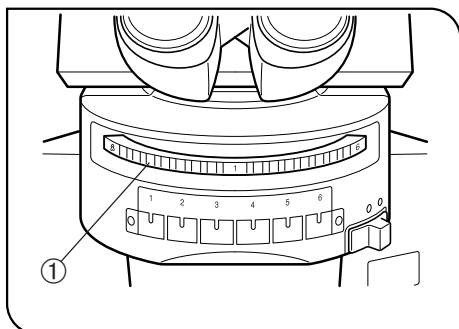

Fig. 18

1 Selecting the Light Path for Observation (Fig. 18)

Rotate the turret ① to set the mirror unit matching the required observation method in the light path.

	Inscription	Mirror Unit	Field Iris	Aperture Iris
Reflected light brightfield	BF	U-MBF3	Adjust as required.	
Reflected light darkfield	DF	U-MDF3	Must be open.	

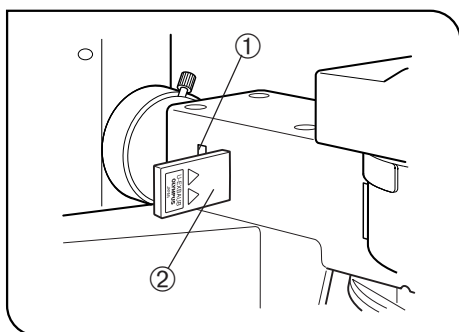

Fig. 19

2 Applications of Filters (Fig. 19)

As necessary up to two filters may be individually inserted into the filter insertion positions ① and ②. Insert each filter with the marked side facing toward the observer.

As you insert the filter, you will hear two clicks. At the first, the filter is in the empty position, and at the second the filter is engaged in the light path.

	Usable Filters	Applications
①	U-25FR (Frost filter)	To eliminate uneven illumination.
②	U-25LBD (Color temperature conversion filter)	To convert the color temperature of the source to the color temperature of daylight. Used for comfortable observation and when taking color photographs.
	U-25IF550 (Green filter)	To increase contrast during monochrome observation. Used when taking monochrome photographs.
	U-25Y48 (Yellow filter)	To achieve good contrast for semiconductor wafers.
	U-25ND50-2 (Neutral Density filter)	To adjust illumination brightness. (Transmittance 50%)
	U-25ND25-2 (Neutral Density filter)	To adjust illumination brightness. (Transmittance 25%)
	U-25ND6-2 (Neutral Density filter)	To adjust illumination brightness. (Transmittance 6%)
	U-25L42	To prevent the polarizer burning when a light source with high intensity is used.

4-2 Reflected Light Nomarski Differential Interference Contrast (DIC) Observation

- ★ The performance of polarizer may deteriorate when it has been exposed to light for a long period (about continuous 2000 hours). If this happens, replace the polarizer.
- ★ When using the high-intensity light source, be sure to use the U-25L42 filter for prevention of the polarizer burn.
- ◎ When performing sensitive color observation using the U-DICRH DIC slider, combine the U-POTP3 polarizer.

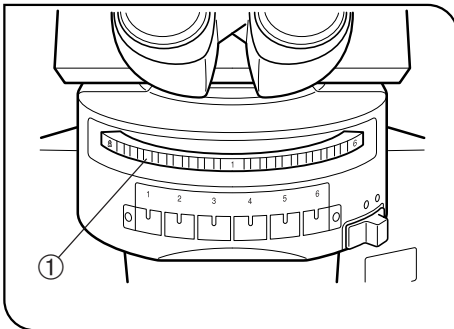

Fig. 20

1 Selecting the Light Path for Observation (Fig. 20)

1. Rotate the turret to engage the BF mirror unit ① in the light path.

	Inscription	Mirror Unit	Note
Reflected light Nomarski DIC	BF	U-MBF3	
	DIC	U-MDIC3	Analyzer/polarizer built in

- ◎ When the U-MDIC3 DIC mirror unit is mounted in the turret, engage the DIC mirror unit in the light path. The analyzer and polarizer are set to the "Crossed Nicol" position so adjustment is not required.
2. Engage the U-AN360-3 analyzer and U-PO3 polarizer in the light path.
 3. Rotate the analyzer dial until complete extinction (crossed Nicol position) is obtained.

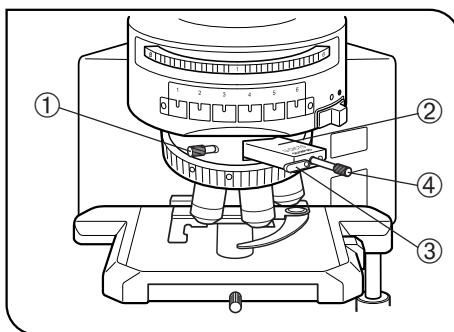

Fig. 21

2 Installing the Nomarski Prism (Fig. 21)

1. Loosen the DIC clamping knob ① at the front of the DIC revolving nose-piece, and insert the DIC prism ② with the inscription facing upward.
2. With the U-DICR interference slider, set the slide lever ③ according to the objective in use.

Lever ③ position	Applicable Objectives	
Pushed in	UIS2	MPLFLN/MPLFLN-BD series MPLAPON series
	UIS	UMPlanFI/UMPlanFI-BD series MPlanApo20X, 100X MPlanApo100XBD
Pulled out	UIS2	LMPLFLN/LMPLFLN-BD series
	UIS	LMPlanFI/LMPlanFI-BD series LMPlanApo/LMPlanApo-BD series

3. With the U-DICRH or U-DICRHC slider that does not have the slide lever, the applicable objectives are as follows.

DIC Slider	Applicable Objectives	
U-DICRH	UIS2	MPLFLN/MPLFLN-BD series MPLAPON series
	UIS	UMPlanFI/UMPlanFI-BD series MPlanFI-BD series MPlanApo20X, 100X
U-DICRHC	UIS2	LMPLFLN/LMPLFLN-BD series
	UIS	LMPlanFI/LMPlanFI-BD series LMPlanApo/LMPlanApo-BD series

3 Observation Procedure

1. Place the specimen on the stage and move the stage to bring the specimen into focus.
2. Adjust the field iris diaphragm until it circumscribes the field of view.
3. Stopping down the aperture iris diaphragm may increase the contrast somewhat.

U-DICR

U-DICRHC

1. Rotate the prism control knob ④ for the DIC prism to adjust the background contrast as outlined below.
2. Rotating the prism control knob of the DIC prism will continuously change the interference color of the background from the gray sensitive color to magenta sensitive color (-100 to 600 nm). Select the interference color offering optimum contrast for each specimen.
 - If the background color is gray, a 3D-looking observation with good contrast is possible in the most sensitive gray colors.
 - If the background color is sensitive magenta, even a minor optical retardation can be observed as a color change.

U-DICRH

1. Rotate the prism control knob ④ for the DIC prism to adjust the background contrast as outlined below.
2. Rotating the prism control knob of the U-DICRH DIC prism will continuously change the interference color of the background from -100 to 100 nm. Select the retardation offering optimum contrast.
 - If the background color is gray, a 3D-looking observation with good contrast is possible in the most sensitive gray colors.
 - If the background color is sensitive magenta, even a minor optical retardation can be observed as a color change.
To use the background color sensitive magenta, use the U-POTP3 polarizer. Position the polarizer so that the λ symbol can be seen from the front when the polarizer is inserted into the inlet slot.

★ Care should be taken to keep the specimen surface clean, as even a small amount of contamination on the surface may show up due to the exceptionally high sensitivity of the DIC method.

© Since the detection sensitivity is variable depending on orientation, it is recommended to use a rotary stage.

4

Switching Between Brightfield and Darkfield Observation

1. Loosen the DIC clamping screw ① at the front of the revolving nose-piece, and gently pull the DIC prism ② outward until a click is heard. Tighten the clamping screw again.
2. Rotate the turret to disengage the U-MDIC3 DIC mirror unit from the light path.
Or slide the analyzer/polarizer to disengage it from the light path.

4-3 Reflected Light Simple Polarized Light Observation

©To prepare for simple polarized light observation using the reflected illuminator, perform the operations in paragraph **1** "Selecting the Light Path" in section 4-2, "Reflected Light Nomarski DIC Observation" on page 38.

1

Observation Procedure

1. Place the specimen on the stage and move the stage to bring the specimen into focus. Simple polarized light observation is now possible.
2. Adjust the field iris diaphragm until the diaphragm opening circumscribes the field of view.
3. Stopping down the aperture iris diaphragm may increase the contrast somewhat.

5 OPTICAL CHARACTERISTICS «UIS2 Series for Reflected Light Observation»

- The UIS series objectives that are not mentioned below can also be mounted on this microscope. -

The table below shows the optical characteristics of different eyepiece and objective combinations. Objective specifications are marked on the objective (as shown in the diagram on the right).

NOTE

Refer to the latest catalogue or consult Evident for the updated information on the eyepieces and objectives that can be combined with this unit.

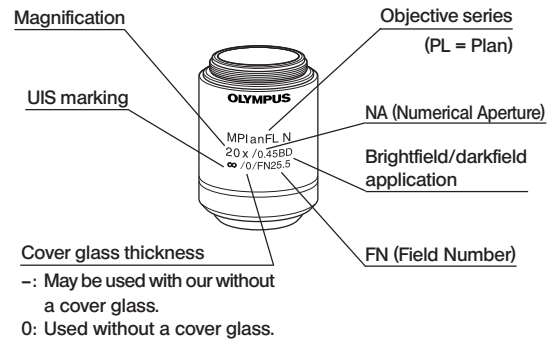

UIS2 series	Optical characteristics Series Marking		Magnification	N.A.	W.D. (mm)	Cover glass thickness (mm)	Resolution (μm)	Eyepieces					
								WHN10X (FN22)			SWH10X (FN26.5)		
								Total mag.	Depth of focus (μm)	Field of view (mm)	Total mag.	Depth of focus (μm)	Field of view (mm)
UIS2 series	MPLN Plan Achromat (FN22)	MPlanN	5X	0.10	20.0	-	3.36	50X	98	4.4	-	-	-
			10X	0.25	10.6	-	1.34	100X	18	2.2	-	-	-
			20X	0.40	1.3	0	0.84	200X	6.1	1.1	-	-	-
			50X	0.75	0.38	0	0.45	500X	1.4	0.44	-	-	-
			100X	0.90	0.21	0	0.37	1000X	0.73	0.22	-	-	-
	MPLN-BD Brightfield/darkfield Plan Achromat (FN22)	MPlanN-BD	5X	0.10	12.0	-	3.36	50X	98	4.4	-	-	-
			10X	0.25	6.5	-	1.34	100X	18	2.2	-	-	-
			20X	0.40	1.3	0	0.84	200X	6.1	1.1	-	-	-
			50X	0.75	0.38	0	0.45	500X	1.4	0.44	-	-	-
			100X	0.90	0.21	0	0.37	1000X	0.73	0.22	-	-	-
	MPLFLN Plan Semi-Apochromat (FN26.5) *1.25X:FN22	MPlanFLN	1.25X	0.04	3.5	-	8.39	12.5X	870	176	-	-	-
			2.5X	0.08	10.7	-	4.19	25X	220	8.8	25X	220	10.6
5X			0.15	20.0	-	2.24	50X	59	4.4	50X	59	5.3	
10X			0.30	11.0	-	1.12	100X	15	2.2	100X	15	2.65	
20X			0.45	3.1	0	0.75	200X	5.2	1.1	200X	5.2	1.33	
50X			0.80	1.0	0	0.42	500X	1.3	0.44	500X	1.3	0.53	
100X			0.90	1.0	0	0.37	1000X	0.73	0.22	1000X	0.73	0.27	
MPLFLN-BD Brightfield/darkfield Plan Semi-Apochromat (FN26.5)	MPlanFLN-BD	5X	0.15	12.0	-	2.24	50X	59	4.4	50X	59	5.3	
		10X	0.30	6.5	-	1.12	100X	15	2.2	100X	15	2.65	
		20X	0.45	3.0	0	0.75	200X	5.2	1.1	200X	5.2	1.33	
		50X	0.80	1.0	0	0.42	500X	1.3	0.44	500X	1.3	0.53	
		100X	0.90	1.0	0	0.37	1000X	0.73	0.22	1000X	0.73	0.27	
MPLFLN-BDP Reflected Polarized Light Plan Semi-Apochromat (FN26.5)	MPlanFLN-BDP	5X	0.15	12.0	-	2.24	50X	59	4.4	50X	59	5.3	
		10X	0.25	6.5	-	1.34	100X	18	2.2	100X	18	2.65	
		20X	0.40	3.0	0	0.84	200X	6.1	1.1	200X	6.1	1.33	
		50X	0.75	1.0	0	0.45	500X	1.4	0.44	500X	1.4	0.53	
		100X	0.90	1.0	0	0.37	1000X	0.73	0.22	1000X	0.73	0.27	
LMPLFLN Long-WD Plan Semi-Apochromat (FN26.5)	LMPlanFLN	5X	0.13	22.5	-	2.58	50X	70	4.4	50X	70	5.3	
		10X	0.25	21.0	-	1.34	100X	18	2.2	100X	18	2.65	
		20X	0.40	12.0	0	0.84	200X	6.1	1.1	200X	6.1	1.33	
		50X	0.50	10.6	0	0.67	500X	2.5	0.44	500X	2.5	0.53	
		100X	0.80	3.4	0	0.42	1000X	0.87	0.22	1000X	0.87	0.27	
LMPLFLN-BD Brightfield/darkfield long-WD Plan Semi-Apochromat (FN26.5)	LMPlanFLN-BD	5X	0.13	15.0	-	2.58	50X	70	4.4	50X	70	5.3	
		10X	0.25	10.0	-	1.34	100X	18	2.2	100X	18	2.65	
		20X	0.40	12.0	0	0.84	200X	6.1	1.1	200X	6.1	1.33	
		50X	0.50	10.6	0	0.67	500X	2.5	0.44	500X	2.5	0.53	
		100X	0.80	3.3	0	0.42	1000X	0.87	0.22	1000X	0.87	0.27	
SLMPLN Superlong-WD Plan Achromat (FN26.5)	SLMPlanN	20X	0.25	25.0	0	1.34	200X	11.4	1.1	200X	11.4	1.33	
		50X	0.35	18.0	0	0.96	500X	4.2	0.44	500X	4.2	0.53	
		100X	0.60	7.5	0	0.56	1000X	1.3	0.22	1000X	1.3	0.27	
MPLAPON Plan Apochromat	MPlanApoN	50X	0.95	0.35	0	0.35	500X	0.7	0.44	500X	0.7	0.53	
		100X	0.95	0.35	0	0.35	1000X	0.4	0.22	1000X	0.4	0.27	

Note) When an MPLN-BD series objective is used in darkfield observation with a xenon light source, the peripheral area may be obscured with certain specimens.

Significance of Objective Name

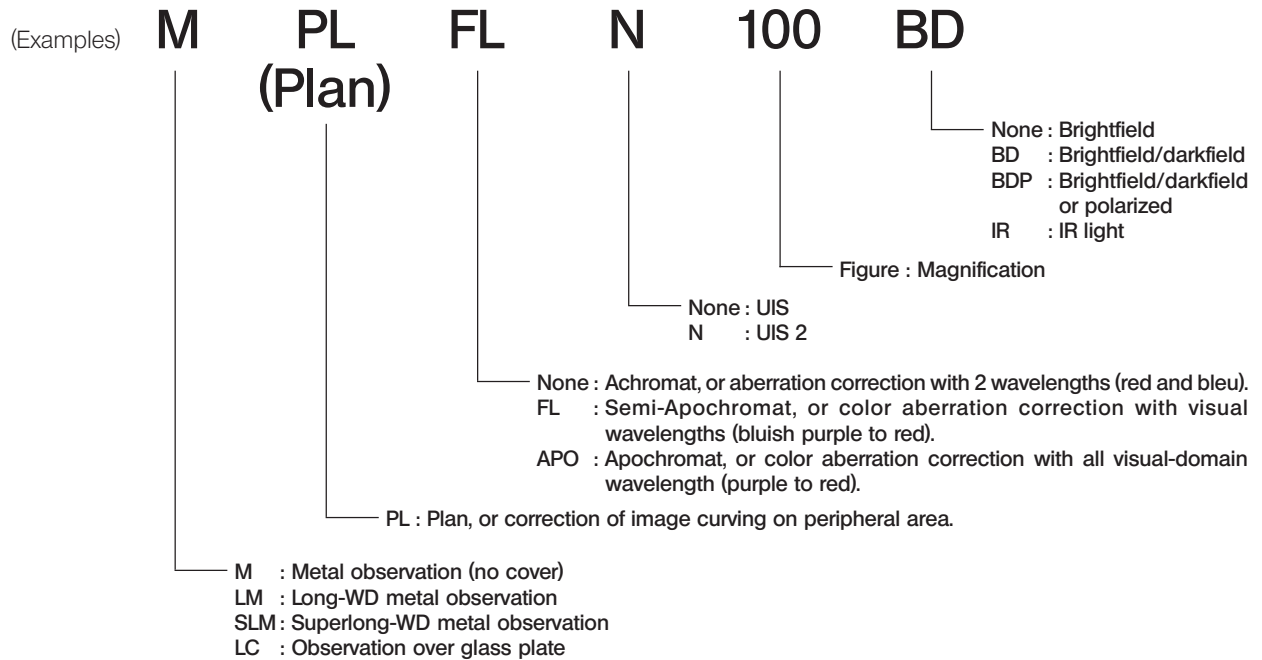

Glossary of Terms Used in the Optical Characteristics Table

- Working distance (WD) : The distance from the top of specimen and the front lens of objective.
- Number of aperture (NA) : Important figure determining the objective characteristics (resolution, focal depth and brightness).
 Resolution Increases in proportion with the NA.
 Focal depth Decreases in proportion with the NA.
 Brightness Proportional with the square of NA (comparison under the same magnification).
- Resolution : The limit that an objective can identify the images of two points that are close to each other, expressed as the distance between the two points on the specimen.
- Depth of focus : The maximum depth of the specimen at which the entire specimen can be brought into focus simultaneously. This value increases when the aperture iris diaphragm is narrowed and decreases when the objective NA is increased.
- Field number : The diameter of the image area that can be observed through the eyepieces, expressed in mm.
- Field of view : The diameter of the area observable on the specimen, expressed in mm.

6 TROUBLESHOOTING GUIDE

Reflected Light Observation Modes

Problem	Cause	Remedy	Page
a) Bulb operates, but field of view remains dark.	Reflected light lamp is not on.	Turn lamp on.	11
	Aperture and field iris diaphragms are not opened wide enough.	Enlarge them to proper sizes.	36
	Mirror unit is not mounted.	Mount mirror unit.	31
	Mirror unit is not correctly engaged in light path.	Engage mirror unit correctly in light path.	37/38
	Optimum mirror unit for observation is not engaged in light path.	Set turret so that optimum mirror unit for observation is engaged in light path.	37/38
b) Field of view is obscured or not evenly illuminated.	Field iris diaphragm has not been centered.	Center field iris diaphragm/	35
	Field iris diaphragm is stopped down too far.	Enlarge field iris diaphragm until it circumscribes field of view.	36
	Mercury burner is not centered correctly.	Center mercury burner.	14
	Frost filter is not engaged in light path.	Engage frost filter in light path.	37
	Filter is not in click position.	Push filter until it clicks properly.	37
c) Image glares.	Aperture iris diaphragm is stopped down too far.	Open aperture iris diaphragm.	36
d) Visibility is poor. <ul style="list-style-type: none"> • Image is not sharp. • Contrast is poor. • Details are indistinct. 	A non-UIS2/UIS objective is used.	Use only UIS2/UIS series objectives with this microscope.	41
	Front lens of objective is dirty.	Clean objective.	3
	Immersion oil is not being used with an oil immersion objective.	Use immersion oil.	—
	Recommended immersion oil is not used.	Use provided immersion oil.	—
	Light shield tube is not attached.	Attach light shield tube.	35
e) One side of image is blurred.	Specimen is tilted.	Place specimen properly on stage and fix with specimen holders.	—
	Revolving nosepiece is not correctly mounted.	Attach revolving nosepiece correctly.	—
	Objective is not correctly engaged in light path.	Engage objective correctly in light path.	—

■ PROPER SELECTION OF THE POWER SUPPLY CORD

If no power supply cord is provided, please select the proper power supply cord for the equipment by referring to “ Specifications ” and “ Certified Cord ” below:

CAUTION: In case you use a non-approved power supply cord for Evident products, Evident can no longer warrant the electrical safety of the equipment.

Specifications

Voltage Rating	125V AC (for 100-120V AC area) or, 250V AC (for 220-240V AC area)
Current Rating	6A minimum
Temperature Rating	60°C minimum
Length	3.05 m maximum
Fittings Configuration	Grounding type attachment plug cap. Opposite terminates in molded-on IEC configuration appliance coupling.

Table 1 Certified Cord

A power supply cord should be certified by one of the agencies listed in Table 1 , or comprised of cordage marked with an agency marking per Table 1 or marked per Table 2. The fittings are to be marked with at least one of agencies listed in Table 1. In case you are unable to buy locally in your country the power supply cord which is approved by one of the agencies mentioned in Table 1, please use replacements approved by any other equivalent and authorized agencies in your country.



















Country	Agency	Certification Mark	Country	Agency	Certification Mark
Argentina	IRAM		Italy	IMQ	
Australia	SAA		Japan	JET, JQA, TÜV, UL-APEX / MITI	
Austria	ÖVE		Netherlands	KEMA	
Belgium	CEBEC		Norway	NEMKO	
Canada	CSA		Spain	AEE	
Denmark	DEMKO		Sweden	SEMKO	
Finland	FEI		Switzerland	SEV	
France	UTE		United Kingdom	ASTA BSI	
Germany	VDE		USA	UL	
Ireland	NSAI				

Table 2 HAR Flexible Cord

APPROVAL ORGANIZATIONS AND CORDAGE HARMONIZATION MARKING METHODS

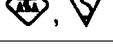
Approval Organization	Printed or Embossed Harmonization Marking (May be located on jacket or insulation of internal wiring)		Alternative Marking Utilizing Black-Red-Yellow Thread (Length of color section in mm)		
			Black	Red	Yellow
Comite Electrotechnique Belge (CEBEC)	CEBEC	⟨HAR⟩	10	30	10
Verband Deutscher Elektrotechniker (VDE) e.V. Prüfstelle	⟨VDE⟩	⟨HAR⟩	30	10	10
Union Technique de l'Electricite' (UTE)	USE	⟨HAR⟩	30	10	30
Instituto Italiano del Marchio di Qualita' (IMQ)	IEMMEQU	⟨HAR⟩	10	30	50
British Approvals Service for Electric Cables (BASEC)	BASEC	⟨HAR⟩	10	10	30
N.V. KEMA	KEMA-KEUR	⟨HAR⟩	10	30	30
SEMKO AB Svenska Elektriska Materielkontrollanstalter	SEMKO	⟨HAR⟩	10	10	50
Österreichischer Verband für Elektrotechnik (ÖVE)	⟨ÖVE⟩	⟨HAR⟩	30	10	50
Danmarks Elektriske Materialkontroll (DEMKO)	⟨DEMKO⟩	⟨HAR⟩	30	10	30
National Standards Authority of Ireland (NSAI)	⟨NSAI⟩	⟨HAR⟩	30	30	50
Norges Elektriske Materielkontroll (NEMKO)	NEMKO	⟨HAR⟩	10	10	70
Asociacion Electrotecnica Y Electronica Espanola (AEE)	⟨UNED⟩	⟨HAR⟩	30	10	70
Hellenic Organization for Standardization (ELOT)	ELOT	⟨HAR⟩	30	30	70
Instituto Portages da Qualidade (IPQ)	np	⟨HAR⟩	10	10	90
Schweizerischer Elektro Technischer Verein (SEV)	SEV	⟨HAR⟩	10	30	90
Elektriska Inspektoratet	SETI	⟨HAR⟩	10	30	90

Underwriters Laboratories Inc. (UL)
Canadian Standards Association (CSA)

SV, SVT, SJ or SJT, 3 X 18AWG
SV, SVT, SJ or SJT, 3 X 18AWG

7 LAMP HOUSING INSPECTION SHEET

- Study the instruction manual for the lamp housing before inspection.
- For safe use of the lamp housing, we recommend performing the following inspection periodically (every time you replace the lamp bulb and at least every 6 months).
- The table below identifies the check items to be observed. Put (X) if not applicable or (√) if applicable.
- If there is any (√) mark noted, immediately stop use of the product, and contact Evident for detailed inspections or replace the lamp housing.
- If you detect an abnormality other than that listed below or with other Evident product, also stop the use of the product and contact Evident for detailed inspections.
- Note that the service, replacement and detailed inspections are charged after expiration of the warranty period.

If you have any questions, please contact Evident.

Check items	Check results (Date)			
	/	/	/	/
1. More than 8 years have passed since original purchase or the total power ON time has exceeded 20,000 hours.				
2. Illumination flickers when you move the lamp cable or lamp housing.				
3. Lamp cable is unusually hot to the touch.				
4. Scorching or burning odor is produced during use.				
5. Deformation, backlash, or looseness, etc. when you assemble the lamp housing. (Impossibility of removing the top section of lamp housing when you attempt to replace the lamp bulb, etc.)				
6. Discoloration, deformation or cracking of the lamp housing.				
7. Melting, crack, deformation or solidification of the lamp cable or a wiring part.				
8. Increased frequency of servicing compared to similar devices put into use at the same time as the lamp housing.				

* When the Check Result columns become insufficient, copy this sheet.

Manufactured by

Evident Corporation

6666 Inatomi, Tatsuno-machi, Kamiina-gun, Nagano 399-0495, Japan

Distributed by

Evident Europe GmbH

Caffamacherreihe 8-10, 20355 Hamburg, Germany

Evident Europe GmbH – UK Branch

Part 2nd Floor Part A, Endeavour House, Coopers End Road, Stansted CM24 1AL, UK

Evident Scientific, Inc.

48 Woerd Ave, Waltham, MA 02453, USA

Evident Scientific Singapore PTE. LTD.

#04-04/05, 25 Ubi Rd 4, UBIX Singapore 408621

Evident Australia PTY LTD

Level 4, 97 Waterloo Road Macquarie Park NSW 2113, Australia

Life science solutions

Service Center



[https://www.olympus-lifescience.com/
support/service/](https://www.olympus-lifescience.com/support/service/)

Official website



<https://www.olympus-lifescience.com>

Industrial solutions

Service Center



[https://www.olympus-ims.com/
service-and-support/service-centers/](https://www.olympus-ims.com/service-and-support/service-centers/)

Official website



<https://www.olympus-ims.com>