

Jueying X30 Pro

User Manual V1.0.6-0(2023.12.20)

Statement

- This manual is the information asset owned by Hangzhou Yunshenchu Technology Co.,Ltd. (hereafter referred to as "DEEP Robotics") and any reprinting of part or all of this manual is strictly prohibited without the permission of DEEP Robotics.
- This manual explains the basic components, transport and storage, specific operations, exception handling, and technical specifications of the quadruped robot "Jueying X30 Pro". Be sure to read and fully understand this manual before operating the robot.
- Basic information on safe use is described in detail in the "Reading Tips", so be sure to read this part thoroughly to ensure proper use.
- The diagrams and photographs in this manual are representative examples and may differ in detail from the product purchased.
- This manual may be modified as appropriate for product improvements, specification changes, etc.
- The contents of this manual do not rule out the possibility of error or omission. If this manual is damaged or lost or if you have questions about the contents of this manual, please contact us promptly.
- Failure caused by unauthorized disassembly or modification of the product by the customer is not covered by our warranty. See "Service and Warranty" for details.

Reading Tips

Description of Symbols

Before use (installation, transportation, maintenance, inspection), please be sure to read and master this manual, and familiarize yourself with the equipment and safety matters before you start using it. The safety matters in this manual are divided into "Caution", "Mandatory" and "Prohibition". Even the contents of "Caution" may cause serious consequences depending on the situation, so any of these safety matters are extremely important and should be strictly observed.



Caution

Usage tips or operational recommendations. Improper using or operating the robot may cause damage to it.



Mandatory

Matters that must be observed.



Prohibition

Matters prohibited. Misoperation is dangerous and may cause injury to operators or damage to the robot.

Help Acquiring

For more resources to assist you in using Jueying X30 Pro proficiently, you can also visit DEEP Robotics' corporate website: <http://www.deeprobotics.cn/>.

Revision History

Version	Modification Time	Modified Content
V1.0.1	2023.10.16	2.2.2 and other details have been revised.
V1.0.2	2023.10.26	Modified the cover picture.
V1.0.3	2023.11.03	Modified the catalog and the front cover.
V1.0.5-0	2023.12.05	Modified the product list, SW2, low battery and Intelligent Controller LEDs.
V1.0.6-0	2023.12.20	Modified the logo and the instructions for carrying

※The final interpretation right belongs to DEEP Robotics.

Content

1 Introduction	1	2.7 Payload and Development	15
1.1 Overview	1	3 Precautions	17
1.2 Product List	1	3.1 Work Environment	17
1.3 Main Specifications	2	3.2 Other Precautions	17
1.4 Power and STOP	4	4 FAQs	18
1.5 Intelligent Controller	5	5 Transport and Storage	19
1.6 Mode and Gait	7	5.1 Transportation	19
2 Operation	8	5.2 Storage	19
2.1 Preparation	8	5.3 Carrying	19
2.1.1 Environment	8	6 Service and Warranty	20
2.1.2 Checking	8	6.1 After-Sales Service	20
2.2 Charging	8	6.2 Warranty Policy	20
2.2.1 Charging the Robot	8	6.3 Warranty Coverage	20
2.2.2 Changing Battery	9	6.4 Repair Instructions	21
2.3 Start	10	7 Disposal	22
2.3.1 Preparation	10		
2.3.2 Power on	10		
2.3.3 Connection	10		
2.4 Motion Control	11		
2.4.1 Controller Operation	11		
2.4.2 Settings	13		
2.5 Emergency Operation	14		
2.5.1 Soft Emergency Stop	14		
2.5.2 Overtemperature	14		
2.5.3 Falling Down	14		
2.5.4 Low Battery	14		
2.5.5 Hard Emergency Stop	14		
2.5.6 Other Circumstances	15		
2.6 Power Off	15		

1 Introduction

1.1 Overview

Jueying X30 Pro is an intelligent quadruped robot designed to meet core industry needs, with a total of 12 degrees of freedom (DOF), capable of walking, going up and down the stairs. The robot is equipped with a wide-angle camera, four laser radars, and two internal hosts respectively for motion control and environmental perception calculation. An additional host inside Intelligent Controller is used for navigation and inspections.

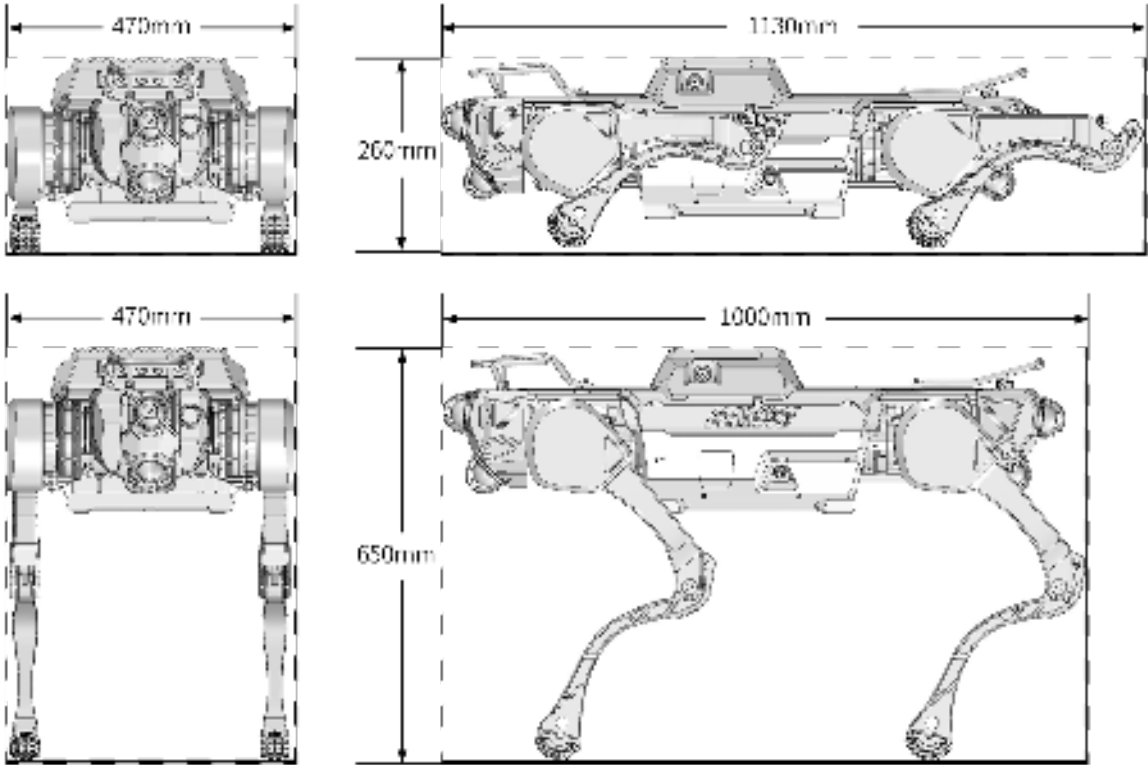

1.2 Product List

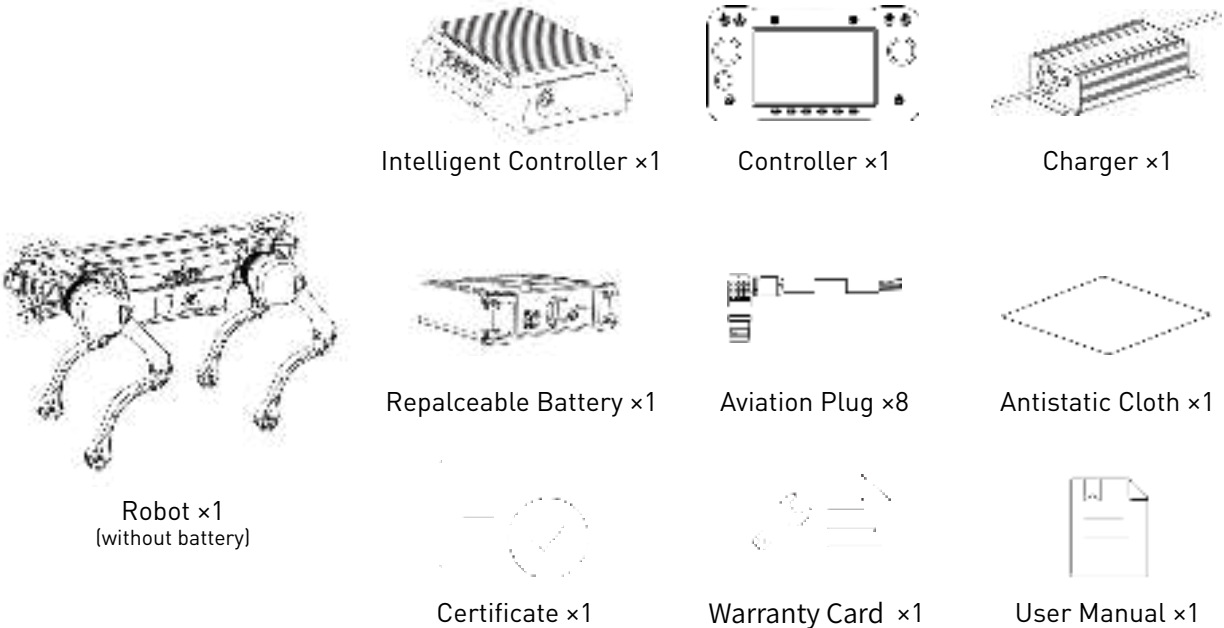

1.3 Main Specifications

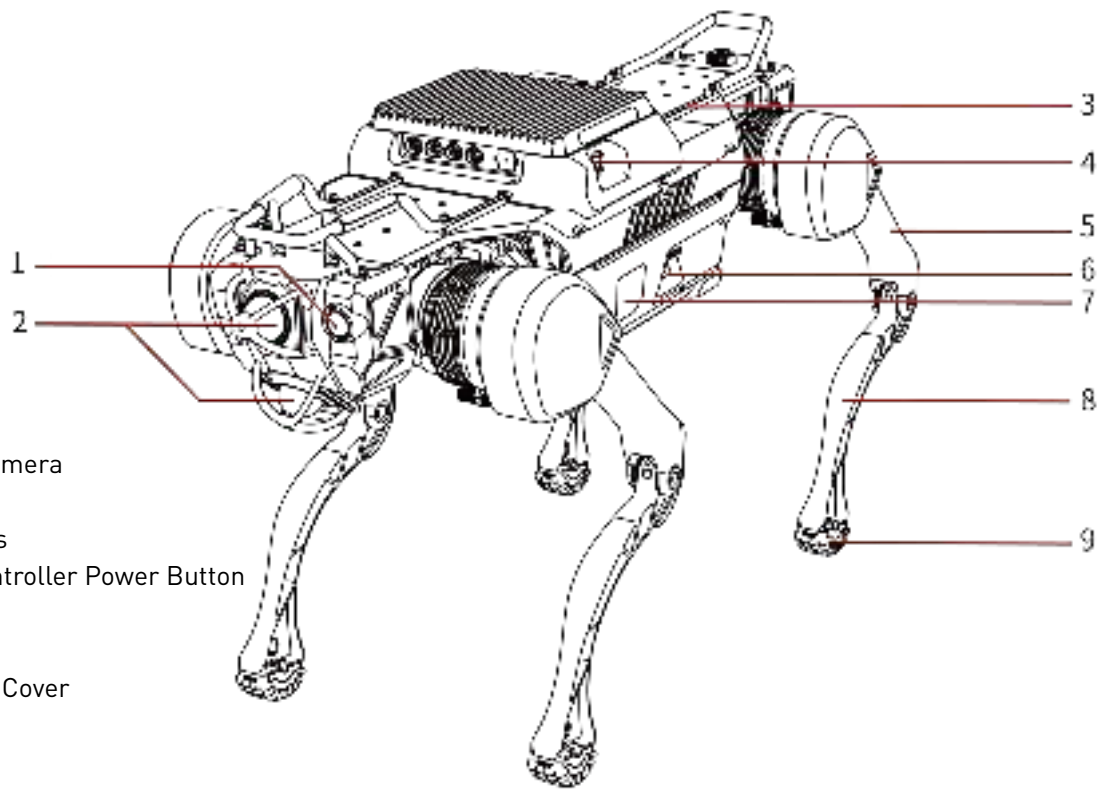

- 1 Wide Angle Camera
- 2 Laser Radar
- 3 Mounting Rails
- 4 Intelligent Controller Power Button
- 5 Upper Leg
- 6 Power Button
- 7 Charging Port Cover
- 8 Lower Leg
- 9 Antislip Foot

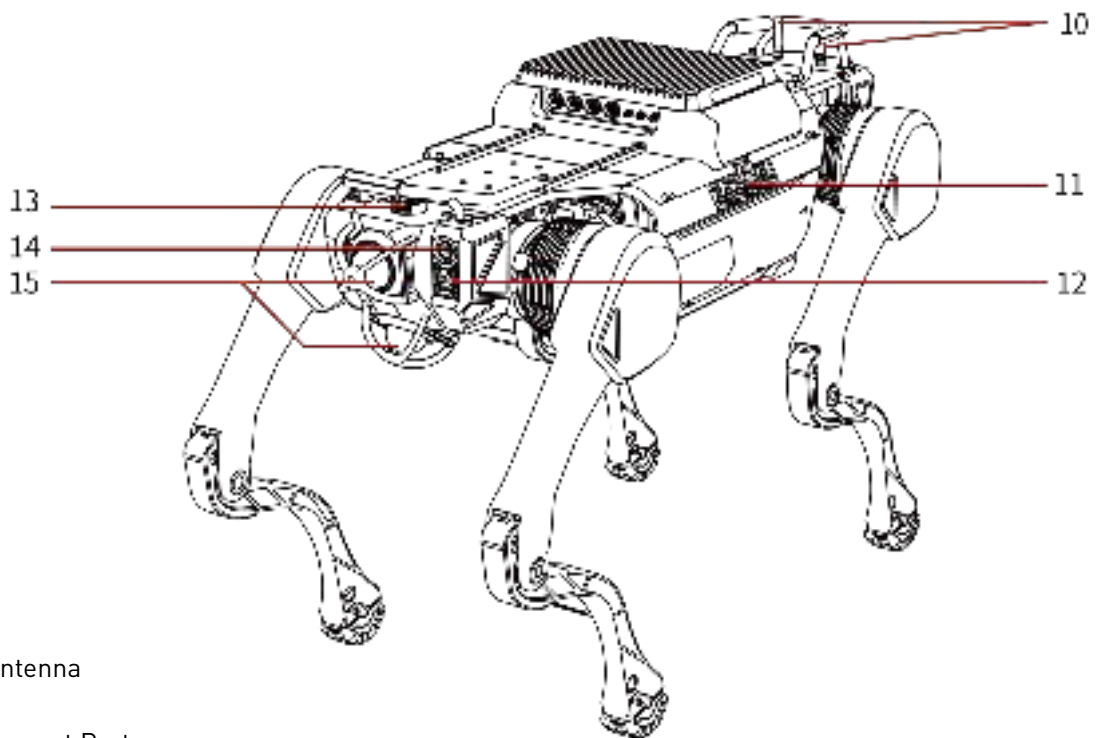

- 10 Controller's Antenna
- 11 Cooling Fan
- 12 Debugging Ethernet Port
- 13 Soft Emergency STOP
- 14 Hard Emergency STOP
- 15 Laser Radar

Robot Dimensions

Sitting Size (Length × Width × Height)	1130mm×470mm×260mm
Standing Size (Length × Width × Height)	1000mm×470mm×650mm
Weight	59kg

Electric Parameters

Battery Capacity	22.4Ah(Ideal data in an environment at 25°C)
Nominal Battery Voltage	72V
Charger Input Voltage	200V~240V
Charger Output	84V/8A
Charging Time	2.5h~3h
Power Supply	12V; 24V; 5V(USB)
Communication Interface	Ethernet; WiFi; USB2.0; USB3.0
Autonomous Charging	Supported

Locomotion Parameters

Maximum Speed	4.95m/s (Data from extreme test)
Normal Walking Speed	1.7m/s
Maximum Slope	±30°
Maximum Step Height	20cm
Maximum Slope of Staircase	±35°
No-load Runtime	4h
Payload Runtime	2.5h
Payload	20kg
Maximum Load	85kg (Data from extreme test)

Sensor Parameters

Laser Radar	×4
Wide-angle Camera	×1
Other Optional Modules	Bi-spectrum PTZ Camera; RTK

Environment Parameters

Ingress Protection	IP67
Operating Temperature	-20°C ~55°C

※Data above is measured under ideal conditions, and the actual results may be biased.

1.4 Power and STOP

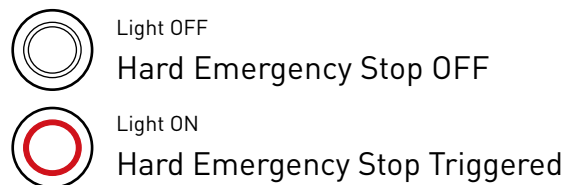
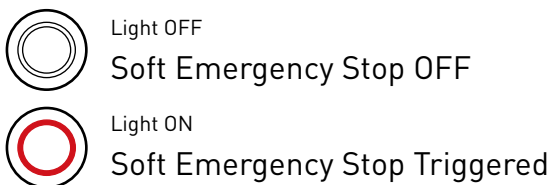
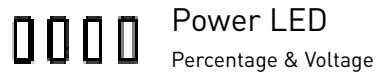
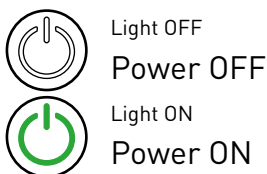
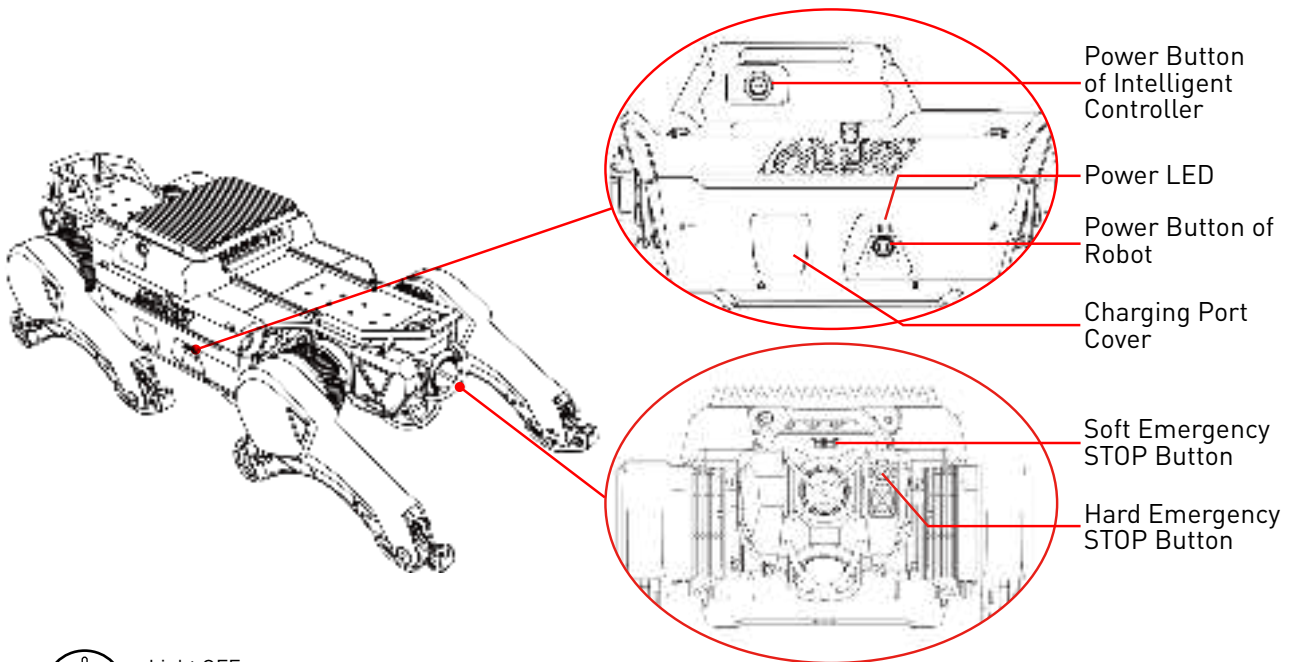

Power LED	
4 lights are always on	75% < Current Battery Level ≤ 100%
1 light is off, 3 lights are always on	50% < Current Battery Level ≤ 75%
2 light are off, 2 lights are always on	25% < Current Battery Level ≤ 50%
3 lights are off, 1 light is flashing	5% < Current Battery Level ≤ 25%
4 lights are off	Current Battery Level ≤ 5%
4 lights cycle on	Charging: Current Battery Level ≤ 25%
1 light is always on, 3 lights cycle on	Charging: 25% < Current Battery Level ≤ 50%
2 lights are always on, 2 lights cycle on	Charging: 50% < Current Battery Level ≤ 75%
3 lights are always on, 1 light flashes	Charging: 75% < Current Battery Level ≤ 100%

1.5 Intelligent Controller

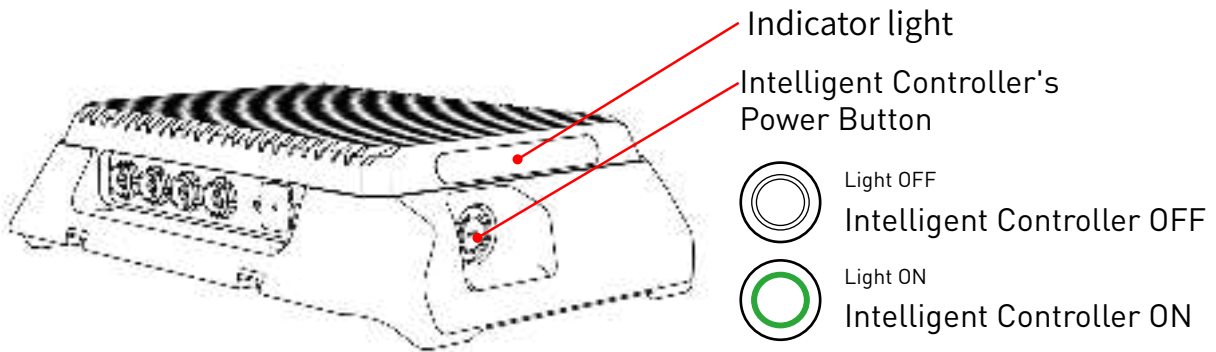

Intelligent Controller Indicator Light	
Always on and green light	Intelligent Controller is working normally.
Green flashing light	Robot is charging.
Yellow flashing light	Robot is avoiding obstacles when in navigation.
Red flashing light	Robot battery is not enough.
Light off	Intelligent Controller is not powered on.

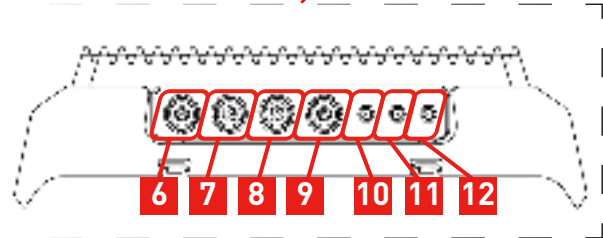
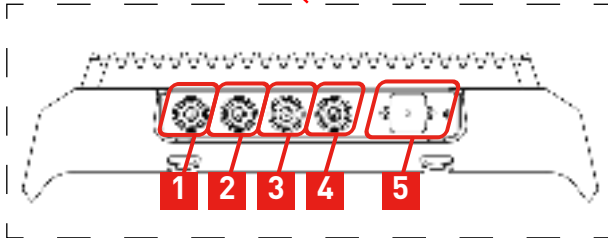
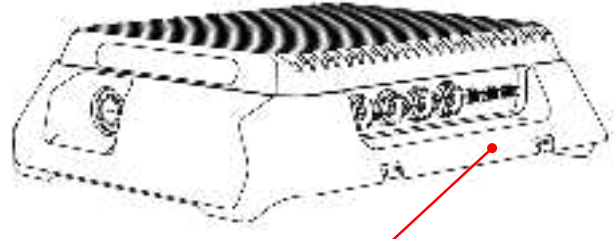
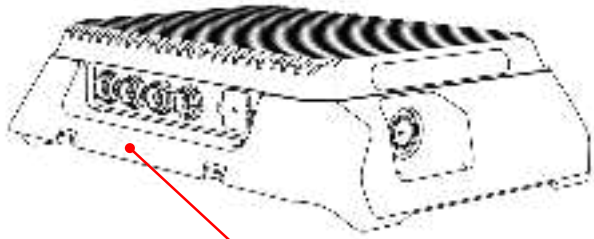

Interface	
① LAN1+24V	⑦ LAN4+12V
② LAN 2+12V	⑧ LAN5+24V
③ LAN3	⑨ LAN6+12V
④ 24V	⑩ GPS Antenna
⑤ USB3.0×2	⑪ & ⑫ RTK antenna
⑥ USB2.0×2	

1.6 Mode and Gait

Control Mode	
Manual	Robot is completely controlled by the user through the controller
Assist	The perception host will monitor the surrounding environment and assist the user in controlling the robot
Navigation	Robot moves autonomously and can not be controlled with the controller

Body Height	
Normal	Robot stands normally
Low	Suitable for passing through the terrain with smaller longitudinal height

Gait	
Walking	Suitable for flat surfaces such as concrete (limited max speed: 1.7m/s)
Running	Suitable for flat surfaces such as concrete (limited max speed: 3m/s)
Slope	Suitable for slopes less than 30° or other gentle irregular terrain
Ordinary Stair	Suitable for climbing steps not higher than 20cm
Perceived Stairs	Robot senses the stair environment and climbs the stairs
Industrial Stairs1	Suitable for industrial grating stairs
Industrial Stairs2	Suitable for industrial stairs without risers

The riser of a stair refers to the vertical component that connects one step or tread to another.

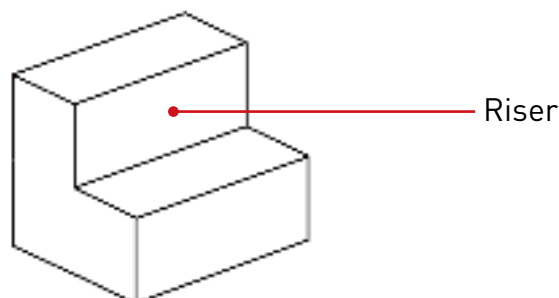

	<p>When the robot passes through stairs or slopes, do not stand on the stairways, platforms or slopes below the robot, to avoid possible personal injury if the robot falls.</p>
--	--

2 Operation

2.1 Preparation

2.1.1 Environment

	<ul style="list-style-type: none">• Please ensure that operators and non-operators present have read the manual carefully and understand the basic operating instructions and safety precautions.• Before start Jueying X30 Pro, ensure that all people or objects present are more than 2 meters away from the robot to avoid collisions.• Please use Jueying X30 Pro in an environment of $-20^{\circ}\text{C} \sim 55^{\circ}\text{C}$.
---	--

2.1.2 Checking

	<ul style="list-style-type: none">• Check the battery indicator. It is suggested to use the robot when the battery is at least 75%.• Make sure that the emergency stop buttons stay off.• Make sure there is no visible damage to the exterior of the robot.• Make sure the joystick used for remote control is fully charged.
--	---

	<p>If the robot parts are aging or damaged, please do not start the robot and contact the after-sales staff in time.</p>
---	--

2.2 Charging

2.2.1 Charging the Robot

Jueying X30 Pro is powered by a ternary lithium battery.

You can connect the robot with 220V AC power supply through the charger, and the charging port is located on the left side.

1. First make sure the robot is turned off. Open the charging port cover and connect the charger to the charging port and tighten it (charger has an anti-reverse plug-in port), then connect it to 220V AC power.
2. During charging, the charging indicator on the charger is red.
3. When charging is complete, the charging indicator on the charger turns green.

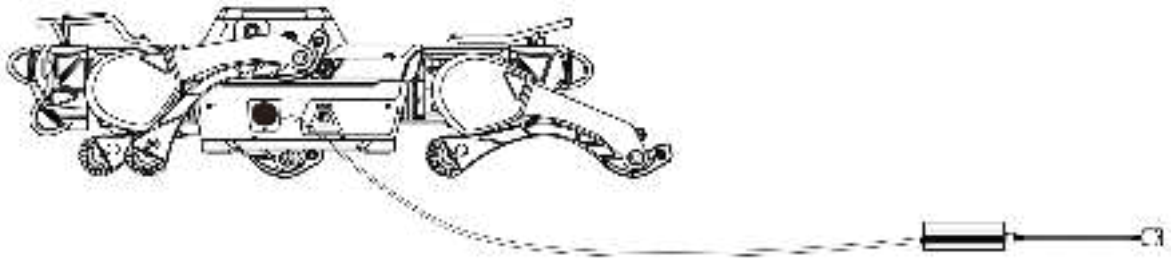

2.2.2 Changing Battery

The battery of Jueying X30 Pro is replaceable, so users can take out the battery and replace it with other batteries, and charge the removed battery separately.

1. Unscrew the four M3 screws on the battery cover plate, and remove the battery cover plate:

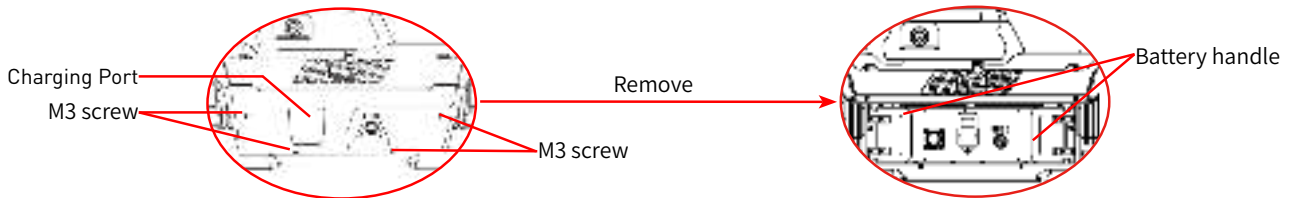

2. Straighten the battery handle outward and take out the battery, then connect the charger for charging:

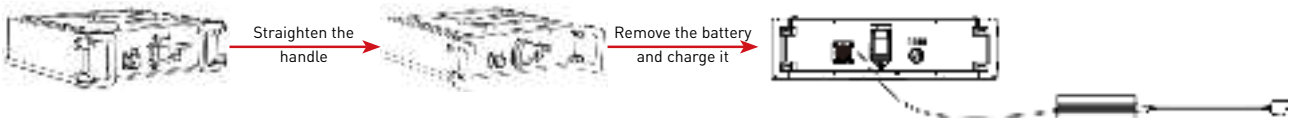

3. When charging normally, the charging indicator light on the charger is red; when charging is complete, the charging light on the charger turns green.

	<ul style="list-style-type: none"> • It is recommended to charge in an environment of 0 °C to 45°C . • During charging, please do not power on the robot and always pay attention to the state of the charger during charging to avoid accidents. Disconnect the charging power supply in time after charging. • When the robot is not charging, the charging port cover must be closed to prevent water.
---	--

2.3 Start

2.3.1 Preparation

1. Take the robot from the transport case and place it on a flat surface, as described in the section "Transport and Storage".

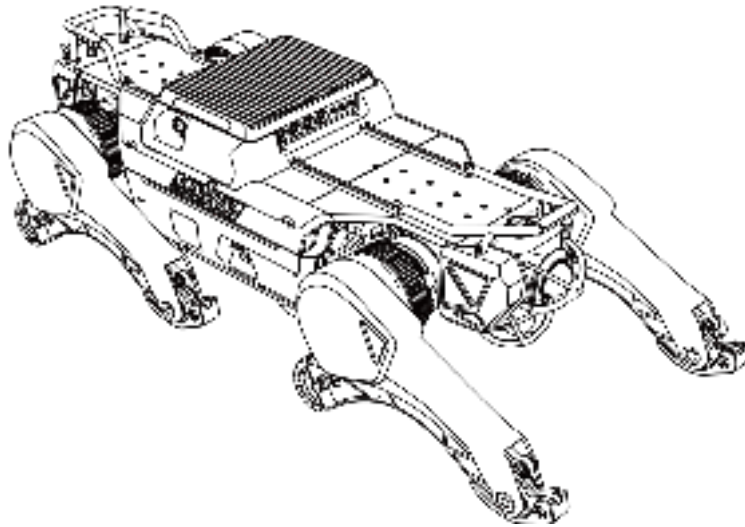

2. Adjust the robot pose as required (as shown in the picture above): knee joints retracted, hip front swing joints swung back, side swing joints vertical, and the bottom of the body touching the ground.

2.3.2 Power on

Press the power button to turn on the robot. At this time, the power button is always on. At the same time, it is necessary to ensure that the soft emergency stop and the hard emergency stop are off. If anyone is on, press the hard emergency stop button or rotate it in the direction indicated by the arrow on the button to turn it off. If the hard emergency stop is triggered, it is necessary to restart the robot after turning off the hard emergency stop.

2.3.3 Connection

Long press the power button to turn on the controller (please ensure that the controller is fully charged). The robot and controller have been paired and bound. After opening the app, the controller will automatically connect to the robot it is bound to.

2.4 Motion Control

2.4.1 Controller Operation

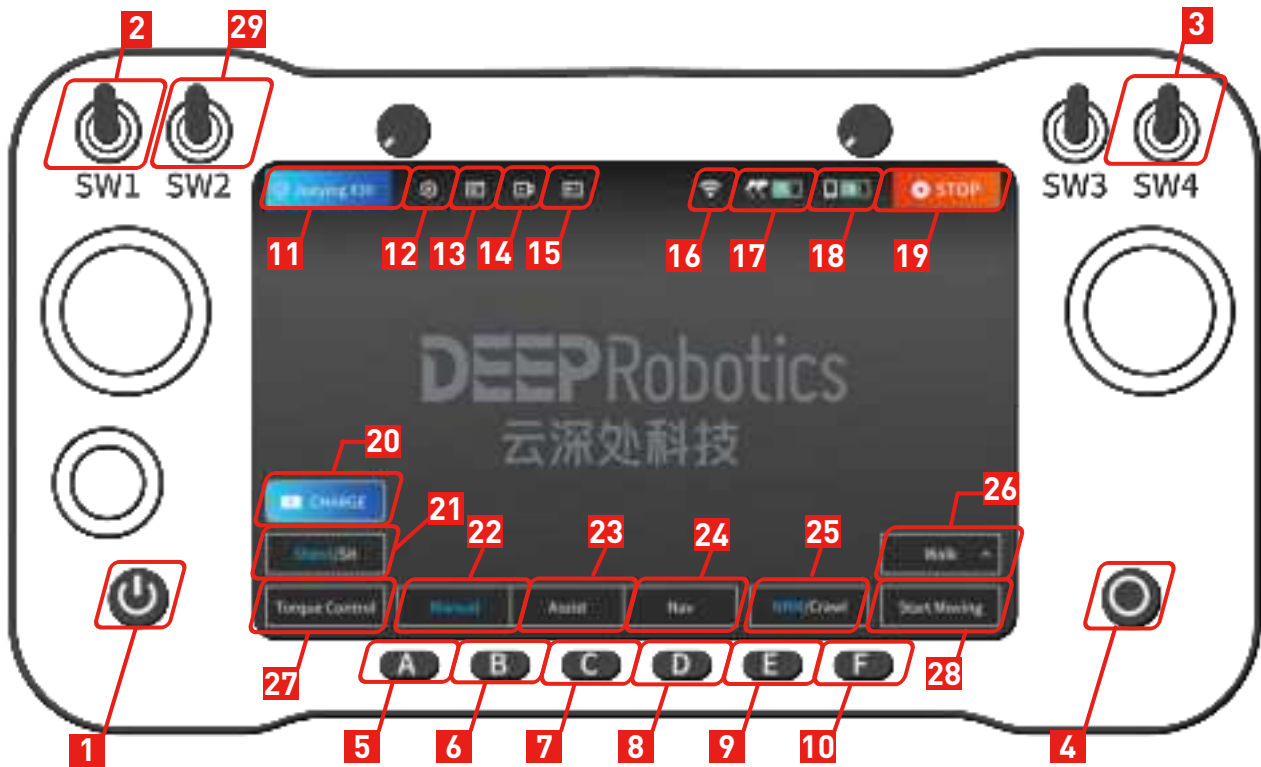

Button		
① Controller Power	Press and hold to power on/off, and press once to wake	
② SW1	Flip up simultaneously	Trigger Soft Emergency Stop
③ SW4	Flip to the center simultaneously	Cancel Soft Emergency Stop
④ Start/Stop Moving	Start or stop moving, that is, to start or stop stepping	
⑤ A	Stand up or sit down	
⑥ B	Switch to Torque Control Mode to unlock each joint	
⑦ C	Switch to Walk gait	
⑧ D	Switch to Run gait	
⑨ E	Switch to Slope gait	
⑩ F	Switch to Stairs gait	
⑪ Connect	Connect to Robot	
⑫ Settings	View APP version/Set language/Save data	

Button		
⑬ Buttons Introduction	Show the introduction to physical buttons	
⑭ Screenshot	Save images for the video streaming	
⑮ Record	Record a video of the video streaming	
⑯ Robot Signal	Real-time display of robot signal strength	
⑰ Robot Battery	Real-time display of robot signal strength	
⑱ Controller Battery	Real-time display of the controller's remaining battery	
⑲ STOP	Soft emergency stop	
⑳ Autonomous charging	Make the robot perform autonomous charging. Please refer to the autonomous charging manual for specific usage.	
㉑ Stand/Sit	Stand up or sit down and the button displays the current status	
㉒ Manual	Switch to Manual Mode	
㉓ Assist	Switch to Assist Mode	
㉔ Navigation	Switch to Navigation Mode	
㉕ Body height	Select body height: Normal/Crawling	
㉖ Gait	Select gait: Walk/Run/Slope/Stair/Perceived Stairs/Industrial Stairs1/Industrial Stairs2	
㉗ Torque Control	Switch to Torque Control Mode to unlock each joint	
㉘ Start/Stop Moving	Start or stop moving, that is, to start or stop stepping	
㉙ SW2	Flip to the center	Show the real-time video from the robot
	Flip up or down	Close the real-time video from the robot

- After connecting the robot, ⑪ will display the name of the robot, at which point you can start controlling the robot.
- After starting, the joints of the robot are locked. In this state, only controlling the robot to lie down and stand is allowed by pressing ⑤ or ㉑ .
- Each time the robot stands up, first press ⑥ or ㉗ to switch to Torque Control Mode, so that the robot can move or twist. Then press ④ or ㉘ to make the robot start moving, that is, it will start stepping with the currently selected gait. At this moment, the left stick controls the robot to move forward, backward, left and right. After releasing the stick, the robot decelerates to zero and steps in place. The right stick controls the robot to turn left and right. Press ④ or ㉘ again to stop the robot stepping. If the robot is

walking forward, it will take some time to slow down and stop.

- Soft emergency stop on Controller: Triggered by flip ② and ③ up simultaneously or clicking ⑱ .

2.4.2 Settings

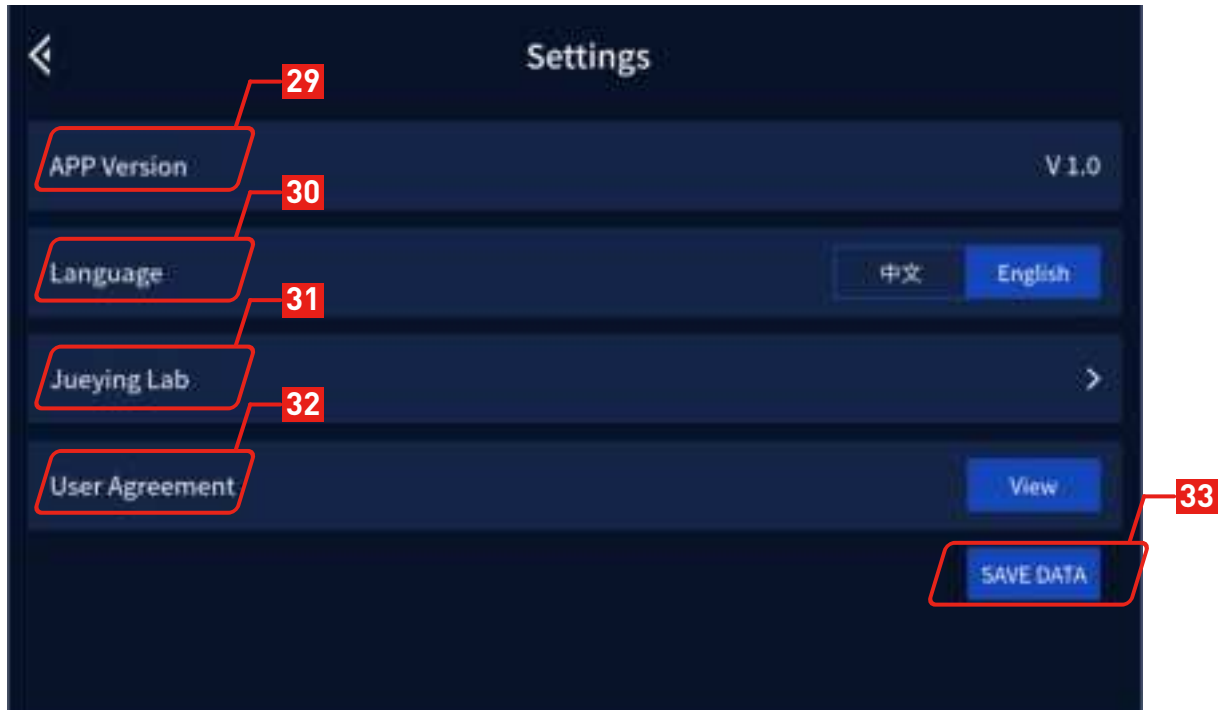

Button	
⑲ APP Version	View the current APP version
⑳ Language	Select language: 中文 /English
㉑ Jueying Lab	Click to enter the "Jueying Lab"
㉒ User Agreement	Click "View" to view the user agreement
㉓ SAVE DATA	Save the data of robot operation

When the robot is abnormal, you can use the ㉓ SAVE DATA to record the abnormal data for troubleshooting. Please ensure that the robot dog is in the state of getting down or emergency stop before using it.

	<ul style="list-style-type: none"> • When operating the robot, please keep at least 2 meters away from the robot to ensure safety! • Dragging, riding and other dangerous interactions with the robot are strictly prohibited during operation! • Never put your hands, feet or other objects within the range of the robot's joints or under the robot.
---	---



- If you encounter problems with Navigation Mode, please switch to Manual Mode in time or press the soft emergency stop button.
- If you want to control the robot to twist, please turn on the enable_twsit switch in the configuration file. Read Application Manual for details.

2.5 Emergency Operation

2.5.1 Soft Emergency Stop

If the robot's legs swing or shake violently and other abnormal phenomena occur during use, please start the soft emergency stop function on Controller (flip ② and ③ up at the same time or click the button ⑱) or push the soft emergency stop button at the tail of the robot to make the robot lie down and enter the self-locking protection state. If the soft emergency stop is triggered by ② and ③ , please flip them back to release the soft emergency stop. If the rear soft emergency stop button is pressed, you need to rotate the button in the direction of the arrow on the button to release it. After releasing the soft emergency stop, please release the force in time (press ⑤ or ⑳) to release the self-locking protection. After troubleshooting, press the stand button again to operate the robot normally.

2.5.2 Overtemperature

The system comes with temperature sensing. Once the robot runs for a long time causing the motor or drive to overheat, it will automatically start the overtemperature protection and the robot will automatically stop moving and get down in place.

2.5.3 Falling Down

If the robot falls down suddenly, the joints will be automatically locked. Please try to click [Stand] button in the app after making sure there is no obstacle around. If the robot still can't get up, press the emergency stop button at the rear of robot, then click [Save Data] at the Settings page of the APP and power off the robot.

2.5.4 Low Battery

When the robot's battery is below 10%, it will enter a low battery warning state, and it should be charged immediately. When the battery level drops below 3%, the robot will trigger a low battery protection mode, where it will automatically lie down and will no longer respond to commands from the remote controller.

2.5.5 Hard Emergency Stop

Hard emergency stop can be triggered by pressing the emergency hard stop button on the rear of the robot, which can ensure that the joints are locked and can prevent the robot from running out of control.



Once the hard emergency stop is triggered, it will cause the robot to lose all kinetic energy and thus fall to the ground. There is a risk of damaging the ground or the robot, so it is strictly forbidden to press the hard stop emergency button during normal movement!

2.5.6 Other Circumstances

- If the joints are not locked or are still swinging after the robot falls down suddenly, wait 30 seconds after the robot joints have completely stopped moving before pressing the hard emergency stop button at the rear of the body.
- In case of a fire, do not use water to extinguish it. Please use foam fire extinguisher, dry powder fire extinguisher or carbon dioxide fire extinguisher nearby.
- If the soft emergency stop button fails or smoke from or water in robot or other unexpected situations, please immediately power off the robot and wait until it's safe to identify the problem. Then please contact DEEP Robotics, and we will help to troubleshoot the problem and repair or change your robot. Pay attention to safety in use!
- If the robot falls, do not drag, push or flip it before triggering the hard emergency stop.

2.6 Power Off



Make sure that the robot is sitting before the following operations.

Press the power button to power off the robot.



After powering off, please cover the robot with the antistatic cloth to avoid dust contamination of laser radar and other devices.

2.7 Payload and Development

Users can attach payloads to the back of the robot or develop new functions based on software interfaces. To learn more about payload development, usage of software interfaces and packages, refer to Application Manual and API Documentation.



- After attaching payloads to the back of the robot, please modify the parameters of payload. To learn more about how to modify the parameters, refer to the chapter "2.2 Parameters Configuration" in Application Manual, or contact after-sales staff.
- The maximum power supplied by the robot to the payload is 350W. For details about the maximum power provided by each power port, read the chapter "5.2 Hardware interface and wiring definition" in Application Manual.
- Please cover the aviation plug with its cover.

3 Precautions

3.1 Work Environment

	<ul style="list-style-type: none"> • Please do not operate the robot in environments with strong WiFi signal interference. Be sure to turn off part or all other WiFi signal sources, and then use the joystick to operate the robot. • Do not operate the robot in such bad weather as fog, snowing, lightning, sandstorms, windstorms, tornadoes, etc. • Keep the robot in sight and always keep it at least 2 meters away from people, water, open flames, etc. • When using the robot on smooth surfaces such as ice, glass and tiles, avoid violent movements and apply Stair or Slope gait to prevent the robot from slipping and falling down. • Do not operate the robot on the edge of a high place to prevent it from falling and causing damage. • Please consult the after-sales staff first before operating the robot in environments with strong electromagnetic interference.
---	---

3.2 Other Precautions

	<ul style="list-style-type: none"> • When carrying the robot, pay attention to the anti-pinch label on the robot and do not put your hands into the position where the anti-pinch label is attached! • Do not lift the robot while it is moving to avoid unintended movements that could cause damage to robot or injury to people!
---	---

	<ul style="list-style-type: none"> • Please do not download other unrelated APPs in the controller. • Pay attention to the sealing label on the robot. It is strictly forbidden to disassemble the robot personally. Once disassembled, the warranty will be invalid!
---	---

4 FAQs

Q1: Is it normal for a robot to stop moving on its own?

A: The motor or driver may be overtemperature protected. Please wait 10 minutes and try again. If you still can't control the robot to move, please check if the battery is fully charged, if the hard emergency stop button is turned off (the button lights blue when off).

Q2: What if there is no response to the commands from APP after connected?

A: First confirm if the hard emergency stop is off (the button lights blue when off). If the APP is still unable to control the robot, please restart the robot.

Q3: Can the robot continue to be used when its body or legs are askew after standing up?

A: At this time, do not continue to click [Force Control]. Please immediately flip ② and ③ up simultaneously or click ⑱ to trigger soft emergency stop to make the robot lie down. Then shut down and restart to try to control the robot to stand up again. If still abnormal, please contact the after-sales staff.

Q4: What if encountering a problem that cannot be solved even after consulting this manual?

A: Click [Save Data] at the Settings page of the APP and contact the after-sales staff in a timely manner.

5 Transport and Storage

5.1 Transportation

The transport case is 1.09m×0.55m×0.57m.



- Before the transport case is being transported on the truck, make sure to step on the two diagonal brake wheels on the transport box.
- During shipping the robot with transport case, make sure the front of the transport case is facing up.

5.2 Storage

- Jueying X30 Pro shall be stored in a clean and dry place at -20°C ~55°C .
- Robot must be powered off.
- Do not pour water or other liquids on the robot.
- Do not place other objects within the joint rotation range.
- Cover the robot completely with a clean antistatic cloth after use.
- It is recommended to store Jueying X30 Pro in the specifically designed transport case to protect it from shock and vibration.
- Jueying X30 Pro must be placed in the transport case with its back facing up.
- If the robot is not used for a long time, charge it every three months to keep the battery active.

5.3 Carrying

Jueying X30 Pro weights approximately 59 kg and it is recommended that two people carry it: one person lifts the anterior carrying point of the robot, while the other lifts the rear carrying point of the robot.

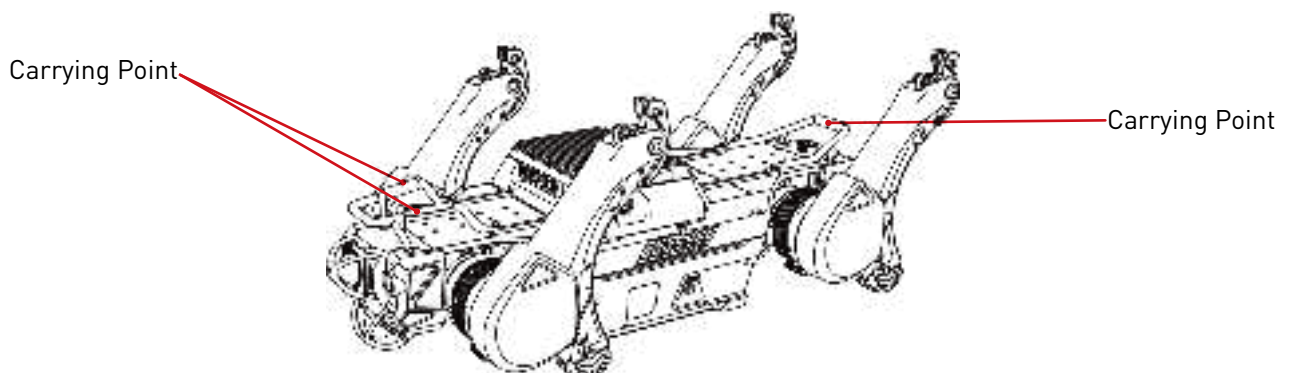

- Power off Jueying X30 Pro and carry it gently.
- Do not hold joints to prevent pinching or even scratching when carrying.
- The metal components of the robot's legs that have just finished running are hot, so please wait until it drops to suitable temperature before carrying.

6 Service and Warranty

6.1 After-Sales Service

- After the delivery of the equipment, DEEP Robotics will send the specialized staff to check the equipment and install the system as agreed.
- Provide free user training to guide users to operate the equipment, and arrange technical support staff to provide timely after-sales service to ensure the smooth operation of the system.

6.2 Warranty Policy

The warranty period for the major components of Jueying X30 Pro is as below.

Component	Warranty Period
Upper Legs, Lower Legs	6 months
Laser Radar, Wide-angle Cameras, Hosts	12 months

Tip: Shell, foot, other wear components, transport case and other accessories are not covered by warranty. If necessary, please consult the after-sales staff.

The warranty period starts from the acceptance date. Products or components that are in the warranty period and covered by warranty acquire free warranty service. If the product you purchased is beyond the warranty period, you can also be helped by us through purchasing the separate service.

6.3 Warranty Coverage

Depending on the specific situations, we will repair or replace components for the product you purchased. However, the following situations will not be covered by the free warranty, but you can still choose the paid warranty service. Please consult the after-sales staff for details:

- Damage caused by man-made problems but not by quality problems of the product itself.
- Personal modification, disassembly or opening of the shell.
- Damage caused by incorrect installation, use and operation in accordance with the manual.
- Damage caused by use in excess of safe load range.
- Damage caused by self-installation of third party products.
- Failure or damage caused by force majeure factors such as typhoon, earthquake, fire, lightning strike, abnormal voltage, etc.

6.4 Repair Instructions

- Before acquiring after-sales service, please make sure to back up all data and delete important data to prevent data loss or leakage. DEEP Robotics is not responsible for any data loss or leakage in the product.
- When you acquire after-sales service from DEEP Robotics, you authorize DEEP Robotics to make any modification, delete data or restore factory settings for the purpose of after-sales service.
- Before sending it for repair, please contact the after-sales staff and DEEP Robotics will try to diagnose and solve your problem remotely.
- If the above methods cannot solve your problem, you can send the robot for repair after verifying with the after-sales staff. You need to pay for the postage when you send the product to DEEP Robotics. After DEEP Robotics receives the problematic product in need of repair, the product will be tested to determine the problem and responsibility.
- If the problem is caused by defects in quality of the product itself, DEEP Robotics will be responsible for the testing fee, material fee, labor fee and your postage.
- If the product does not meet the conditions of free repair after testing, you can choose to pay for repair, and the testing fee, material fee, labor fee as well as the postage for sending back shall be paid by you. You can also choose not to repair and to send product back to you, and the postage and insurance fee shall be paid by you.
- Considering environmental protection and safety, please do not send seriously damaged batteries. If you have sent, DEEP Robotics will scrap such batteries and will not return them back to you.
- If you provide an incorrect delivery address which results in non-delivery or rejection by the recipient, the adverse consequences and losses shall be borne by you.
- To ensure your rights and interests, when you sign for the after-sale product sent by DEEP Robotics, please check carefully whether the product is intact. If there is any abnormality, please immediately take video or photos on the spot and contact DEEP Robotics to get the solutions. If there are unresolved after-sale problems, please also contact DEEP Robotics immediately, otherwise it is deemed as the end of this after-sale service without dispute.

※DEEP Robotics reserves the right of final explanation of the after-sales terms.

※Please contact us if you have any questions before acquiring after-sales service.

※The after-sales terms are only applicable in Chinese mainland, and the after-sales policies of other countries or regions shall be subject to local laws.

7 Disposal

- The disposal of waste robots and components shall be carried out in accordance with the corresponding national laws and regulations on the recycling of wasted electric appliance and electronic products.
- Especially the use or disposal of lithium batteries contained in robots shall be subject to national laws and regulations regarding the disposal of batteries.