

EPSON

Industrial Robot: SCARA Robots

RS series

Manual

Rev.8

ENM263R8443F

Original instructions

RS series Manual

Rev 8

Industrial Robot: SCARA Robots

RS series Manual

Rev.8

FOREWORD

Thank you for purchasing our robot products.

This manual contains the information necessary for the correct use of the manipulator.

Please carefully read this manual and other related manuals before installing the robot system.

Keep this manual handy for easy access at all times.

The robot system and its optional parts are shipped to our customers only after being subjected to the strictest quality controls, tests, and inspections to certify its compliance with our high performance standards. Please note that the basic performance of the product will not be exhibited if our robot system is used outside of the usage conditions and product specifications described in the manuals.

This manual describes possible dangers and consequences that we can foresee. Be sure to comply with safety precautions on this manual to use our robot system safely and correctly.

TRADEMARKS

Microsoft, Windows, and Windows logo are either registered trademarks or trademarks of Microsoft Corporation in the United States and/or other countries. Other brand and product names are trademarks or registered trademarks of the respective holders.

NOTICE

No part of this manual may be copied or reproduced without authorization.

The contents of this manual are subject to change without notice.

Please notify us if you should find any errors in this manual or if you have any comments regarding its contents.

MANUFACTURER

SEIKO EPSON CORPORATION

CONTACT INFORMATION

Contact information is described in "SUPPLIERS" in the first pages of the following manual:

" Robot System Safety Manual Read this manual first"

DISPOSAL

When disposing this product, dispose in accordance with the laws and regulations of each country.

Regarding battery disposal

The battery removal/replacement procedure is described in the following manuals:
Maintenance Manual

For European Union customers only



The crossed out wheeled bin label that can be found on your product indicates that this product and incorporated batteries should not be disposed of via the normal household waste stream. To prevent possible harm to the environment or human health please separate this product and its batteries from other waste streams to ensure that it can be recycled in an environmentally sound manner. For more details on available collection facilities please contact your local government office or the retailer where you purchased this product. Use of the chemical symbols Pb, Cd or Hg indicates if these metals are used in the battery.

NOTE



This information only applies to customers in the European Union, according to Directive 2006/66/EC OF THE EUROPEAN PARLIAMENT AND OF THE COUNCIL OF 6 September 2006 on batteries and accumulators and waste batteries and accumulators and repealing Directive 91/157/EEC and legislation transposing and implementing it into the various national legal systems, and to customers in countries in Europe, Middle East and Africa (EMEA) where they have implemented equivalent regulations.

For other countries, please contact your local government to investigate the possibility of recycling your product.

For Users in Taiwan region



Please separate used batteries from other waste streams to ensure that it can be recycled in an environmentally sound manner. For more details on available collection facilities please contact your local government office or the retailer where you purchased this product.

Before Reading This Manual

This section describes what you should know before reading this manual.

Structure of Control System

The RS series Manipulators can be used with the following combinations of Controllers and software.

Controller		Software
Name	Structure	
RC700-A	Control Unit	EPSON RC+ 7.0 Ver.7.1.2 or greater
	Drive Unit	Epson RC+8.0

The motions of the manipulators such as in emergency stops vary depending on the Controllers since they have different control methods. Details are described in the manual.

Turning ON/OFF Controller

When you see the instruction “Turn ON/OFF the Controller” in this manual, be sure to turn ON/OFF all the hardware components. For the Controller composition, refer to the table above.

Shape of Motors

The shape of the motors used for the Manipulator that you are using may be different from the shape of the motors described in this manual because of the specifications.

Setting by Using Software

This manual contains setting procedures by using software. They are marked with the following icon.

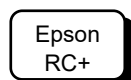

The Manuals of This Product

The following are typical manual types for this product and an outline of the descriptions.

Safety Manual

This manual contains safety information for all people who handle this product. The manual also describes the process from unpacking to operation and the manual you should look at next.

Read this manual first.

- Safety precautions regarding robot system and residual risk
- Declaration of conformity
- Training
- Flow from unpacking to operation

RC700 series Manual

This manual explains the installation of the entire robot system and the specifications and functions of the controller. The manual is primarily intended for people who design robot systems.

- The installation procedure of the robot system (specific details from unpacking to operation)
- Daily inspection of the controller
- Controller specifications and basic functions

RS series Manual

This manual describes the specifications and functions of the Manipulator. The manual is primarily intended for people who design robot systems.

- Technical information, functions, specifications, etc. required for the Manipulator installation and design
- Daily inspection of the Manipulator

Status Code/Error Code List

This manual contains a list of code numbers displayed on the controller and messages displayed in the software message area. The manual is primarily intended for people who design robot systems or do programming.

RC700 series Maintenance Manual

RS series Maintenance Manual

This manual describes the details of maintenance etc. The manual is intended for people who perform maintenance.

- Daily inspection
- Replacement and repair of maintenance parts
- The method of firmware update and controller setting backup etc.

Epson RC+ User's Guide

This manual describes general information about program development software.

Epson RC+ SPEL+ Language Reference

This manual describes the robot programming language "SPEL+".

Other Manual

Manuals for each option are available.

RS3, RS4 Manipulator

1. Safety	3
1.1 Conventions	3
1.2 Design and Installation Safety.....	4
1.2.1 Strength of the Ball Screw Spline	5
1.3 Operation Safety	5
1.4 Emergency Stop	7
1.5 Safeguard	8
1.6 Emergency Movement Without Drive Power.....	9
1.7 ACCELS Setting for CP Motions	11
1.8 Warning Labels	12
1.9 Response for Emergency or Malfunction	16
1.9.1 Collision	16
1.9.2 Getting body caught in Manipulator	16
2. Specifications	17
2.1 Model Number	17
2.2 Part Names and Outer Dimensions	18
2.2.1 RS3-351*	18
2.2.2 RS4-551*	22
2.3 Specifications.....	26
2.4 How to Set the Model.....	26
3. Environments and Installation	27
3.1 Environmental Conditions	27
3.2 Base Table.....	28
3.3 Mounting Dimensions.....	32
3.4 Unpacking and Transportation	33
3.5 Installation.....	34
3.5.1 Standard-model	34
3.5.2 Cleanroom-model	35
3.6 Connecting the Cables.....	36
3.7 User Wires and Pneumatic Tubes	37
3.8 Relocation and Storage.....	38
3.8.1 Precautions for Relocation and Storage.....	38
3.8.2 Relocation procedure.....	39
4. Setting of End Effectors	40
4.1 Attaching an End Effector	40
4.2 Attaching Cameras and Air valves	41
4.3 Weight and Inertia Settings	42
4.3.1 Weight Setting	42
4.3.2 Inertia Setting.....	45
4.4 Precautions for Auto Acceleration/Deceleration of Joint #3	49

5. Motion Range	50
5.1 Motion Range Setting by Pulse Range	50
5.1.1 Max. Pulse Range of Joint #1	51
5.1.2 Max. Pulse Range of Joint #2	51
5.1.3 Max. Pulse Range of Joint #3	52
5.1.4 Max. Pulse Range of Joint #4	52
5.2 Motion Range Setting by Joint #3 Mechanical Stops.....	53
5.3 Setting the Cartesian (Rectangular) Range in the XY Coordinate System of the Manipulator (for Joints #1 and #2).....	54
5.4 Standard Motion Range.....	55

Regular Inspection

1. General Maintenance for RS3 RS4	59
1.1 Maintenance Inspection.....	59
1.1.1 Schedule for Maintenance Inspection	59
1.1.2 Inspection Point.....	60
1.2 Overhaul (Parts Replacement)	61
1.3 Greasing	61
1.4 Tightening Hexagon Socket Head Cap Bolts.....	64

Appendix

Appendix A: Specification	67
RS3 RS4 Specification.....	67
Appendix B: Stopping time and Stopping distance in Emergency	69
RS3 Stopping time and Stopping distance in Emergency	71
RS3-351*: J1.....	71
RS3-351*: J2.....	71
RS3-351*: J3.....	71
RS4 Stopping time and Stopping distance in Emergency	72
RS4-551*: J1.....	72
RS4-551*: J2.....	72
RS4-551*: J3.....	72
Supplementary Information regarding the Stopping Time and Stopping Distance at Emergency Stop	73
How to check the stopping time and stopping distance in the customer's environment	73
Commands that can be useful when measuring stopping time and stopping distance.....	74
Appendix C: Stopping time and Stopping distance When Safeguard Is Opened	75
RS3 Stopping time and Stopping distance When Safeguard Is Opened.....	77
RS3-351*: J1.....	77
RS3-351*: J2.....	77

TABLE OF CONTENTS

RS3-351*: J3	77
RS4 Stopping time and Stopping distance When Safeguard Is Opened	78
RS4-551*: J1	78
RS4-551*: J2	78
RS4-551*: J3	78
Supplementary Information regarding the Stopping Time and Stopping Distance when the Safeguard is Open.....	79
How to check the stopping time and stopping distance in the customer's environment.....	79
Commands that can be useful when measuring stopping time and stopping distance	80

RS3, RS4 Manipulator

This volume contains information for setup and operation of the Manipulators.
Please read this volume thoroughly before setting up and operating the Manipulators.

1. Safety



Unpacking and transportation of the Manipulators and robotic equipment shall be performed by personnel who has taken robot system training held by us and suppliers and should conform to all national and local codes.

Please read this manual and other related manuals before installing the robot system or before connecting cables.

Keep this manual handy for easy access at all times.

1.1 Conventions

Important safety considerations are indicated throughout the manual by the following symbols. Be sure to read the descriptions shown with each symbol.

 WARNING	This symbol indicates that a danger of possible serious injury or death exists if the associated instructions are not followed properly.
 WARNING	This symbol indicates that a danger of possible serious injury caused by electric shock exists if the associated instructions are not followed properly.
 CAUTION	This symbol indicates that a danger of possible harm to people or physical damage to equipment and facilities exists if the associated instructions are not followed properly.

1.2 Design and Installation Safety

This product is intended for transporting and assembling parts in a safely isolated area. Design and installation of robot system shall be performed by personnel who has taken robot system training held by us and suppliers.

To ensure safety, a safeguard must be installed for the robot system. For details on the safeguard, refer to the *Installation and Design Precautions* in the *Safety* chapter of the *Epson RC+ User's Guide*.

The following items are safety precautions for design personnel:

 WARNING	<ul style="list-style-type: none"> ■ Personnel who design and/or construct the robot system with this product must read the “<i>Safety Manual</i>” to understand the safety requirements before designing and/or constructing the robot system. Designing and/or constructing the robot system without understanding the safety requirements is extremely hazardous, may result in serious bodily injury and/or severe equipment damage to the robot system, and may cause serious safety problems. ■ The Manipulator and the Controller must be used within the environmental conditions described in their respective manuals. This product has been designed and manufactured strictly for use in a normal indoor environment. Using the product in an environment that exceeds the specified environmental conditions may not only shorten the life cycle of the product but may also cause serious safety problems. ■ The robot system must be used within the installation requirements described in the manuals. Using the robot system outside of the installation requirements may not only shorten the life cycle of the product but also cause serious safety problems. ■ When designing or installing a robot system, wear at least the following protective gear. Working without protective gear may cause serious safety problems. <ul style="list-style-type: none"> Work clothes suitable for work Helmet Safety shoes
---	---

Further precautions for installation are mentioned in the chapter 3. *Environments and Installation*. Please read this chapter carefully to understand safe installation procedures before installing the robots and robotic equipment.

1.2.1 Strength of the Ball Screw Spline

If a load exceeding the allowable value is applied to the ball screw spline, it may not work properly due to deformation or breakage of the shaft. If the ball screw spline is applied the load exceeding the allowable value, it is necessary to replace the ball screw spline unit.

The allowable loads differ depending on distance where the load is applied to. For calculating the allowable load, see the calculation formula below.

[Allowable bending moment]

$$\text{RS3/RS4: } M=13,000 \text{ N}\cdot\text{mm}$$

Example: If 130 N load is applied
at 100 mm from
the end of the spline nut

[Moment]

$$M=F\cdot L=100\cdot 130=13,000 \text{ N}\cdot\text{mm}$$

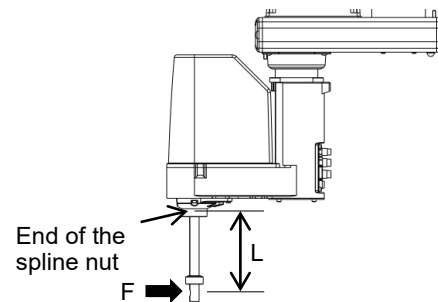



1.3 Operation Safety

The following items are safety precautions for qualified Operator personnel:



- Please carefully read the *Safety Requirements* in the “*Safety Manual*” before operating the robot system. Operating the robot system without understanding the safety requirements is extremely hazardous and may result in serious bodily injury and/or severe equipment damage to the robot system.
- Do not enter the operating area of the Manipulator while the power to the robot system is turned ON. Entering the operating area with the power ON is extremely hazardous and may cause serious safety problems as the Manipulator may move even if it seems to be stopped.
- Before operating the robot system, make sure that no one is inside the safeguarded area. The robot system can be operated in the mode for teaching even when someone is inside the safeguarded area. The motion of the Manipulator is always in restricted (low speeds and low power) status to secure the safety of an operator. However, operating the robot system while someone is inside the safeguarded area is extremely hazardous and may result in serious safety problems in case that the Manipulator moves unexpectedly.
- Immediately press the Emergency Stop switch whenever the Manipulator moves abnormally while the robot system is operated.

 WARNING	<ul style="list-style-type: none"> ■ To shut off power to the robot system, disconnect the power plug from the power source. Be sure to connect the AC power cable to a power receptacle. DO NOT connect it directly to a factory power source. ■ Before performing any replacement procedure, turn OFF the Controller and related equipment, and then disconnect the power plug from the power source. Performing any replacement procedure with the power ON is extremely hazardous and may result in electric shock and/or malfunction of the robot system. ■ Do not connect or disconnect the motor connectors while the power to the robot system is turned ON. Connecting or disconnecting the motor connectors with the power ON is extremely hazardous and may result in serious bodily injury as the Manipulator may move abnormally, and also may result in electric shock and/or malfunction of the robot system.
--	---

 CAUTION	<ul style="list-style-type: none"> ■ Whenever possible, only one person should operate the robot system. If it is necessary to operate the robot system with more than one person, ensure that all people involved communicate with each other as to what they are doing and take all necessary safety precautions. ■ Joint #1, #2, and #4: If the joints are operated repeatedly with the operating angle less than 5 degrees, they may get damaged early because the bearings are likely to cause oil film shortage in such situation. To prevent early breakdown, move each joint larger than 50 degrees for about once an hour. Joint #3: If the up-and-down motion of the hand is less than 10 mm, move the joint a half of the maximum stroke for about once an hour. ■ Vibration (resonance) may occur continuously in low speed Manipulator motion (Speed: approx. 5 to 20%) depending on combination of Arm orientation and end effector load. Oscillation arises from natural oscillation frequency of the Arm and can be controlled by following measures. <ul style="list-style-type: none"> Changing Manipulator speed Changing the teach points Changing the end effector load
--	---

1.4 Emergency Stop

If the Manipulator moves abnormally during operation, immediately press the Emergency Stop switch. Stops the power supply to the motor, and the arm stops in the shortest distance with the dynamic brake and mechanical brake.

Avoid pressing the Emergency Stop switch unnecessarily while the Manipulator is running normally.

- The Manipulator may hit the peripheral equipment.

When you press the Emergency Stop switch, the operating trajectory until the robot system stops is different from that in normal operation.

- The life of the brakes will be shortened.

The brakes are locked and the brake friction plate is worn.

Normal brake life cycle: About 2 years (when the brakes are used 100 times/day)

However, the rough normal relay life is approximately 20,000 times. If you press the emergency stop switch unnecessarily, the life of the relay will be shortened.

- Impact is applied on the reduction gear unit, and it may result in the short life of the reduction gear unit.

To place the system in emergency mode during normal operation, press the Emergency Stop switch when the Manipulator is not moving.

Refer to the Controller manual for instructions on how to wire the Emergency Stop switch circuit.

Do not press the Emergency Stop switch unnecessarily while the Manipulator is operating. Pressing the switch during the operation makes the brakes work. This will shorten the life of the brakes due to the worn friction plates.

Normal brake life cycle: About 2 years (when the brakes are used 100 times/day)

Do not turn OFF the Controller while the Manipulator is operating.

If you attempt to stop the Manipulator in emergency situations, make sure to stop the Manipulator using the E-STOP of the Controller.

If the Manipulator is stopped by turning OFF the Controller while it is operating, following problems may occur.

Reduction of the life and damage of the reduction gear unit

Position gap at the joints

In addition, if the Controller was forced to be turned OFF by blackouts and the like while the Manipulator is operating, make sure to check the following points after power restoration.

Whether or not the reduction gear is damaged

Whether or not the joints are in their proper positions

If there is a position gap, perform calibration by referring to the *RS series Maintenance Manual 13. Calibration* in this manual.

Before using the Emergency Stop switch, be aware of the followings.

- The Emergency Stop (E-STOP) switch should be used to stop the Manipulator only in case of emergencies.
- To stop the Manipulator operating the program except in emergency, use Pause (halt) or STOP (program stop) commands.
Pause and STOP commands do not turn OFF the motors. Therefore, the brake does not function.
- For the Safeguard system, do not use the circuit for E-STOP.



To check brake problems, refer to *Regular Inspection*.

Test pulse cannot be used with the emergency stop input of this model.

Stopping distance in emergency

The operating Manipulator cannot stop immediately after the Emergency Stop switch is pressed. In addition, stopping time and stopping distance vary by following factors:

- Hand weight WEIGHT Setting ACCEL Setting
- Workpiece weight SPEED Setting Posture etc.

For stopping time and stopping distance of the Manipulator, refer to “*Appendix B: Stopping Time and Stopping Distance in Emergency*”.

1.5 Safeguard

To ensure safe operation, install a safety system using safety doors, light curtains, safety floor mats, etc.

When a closed safeguard is open during robot motion, the safeguard interlock function operates. The robot stops immediately and enters into pause state. Then, all robot motors are turned OFF. The descriptions below explain how the safeguard input works.

Safeguard open : The robot stops immediately, motors are turned OFF, and further operation is impossible until either the safeguard is closed or TEACH or TEST mode is turned ON and the enable circuit is engaged.

Safeguard closed : The robot can automatically operate in unrestricted (high power) state.

Do not open the safeguard unnecessarily while motor is ON. Frequent safeguard inputs affect the life of the relay.

Rough normal relay life: Approximately 20,000 times

For the safeguard, do not use the E-STOP circuit.

For details of wiring instructions, refer to the following manual:

RC700 series Manual - Functions required for designing - 11. EMERGENCY

For details of Safeguard, refer to the following manual:

RC700 series Manual - Installation - 2.7.1 Connection to EMERGENCY Connector



Test pulse cannot be used with the safeguard input of this model.



WARNING

- The EMERGENCY connector on the controller has a safeguard input circuit to connect the safety device interlock switch. To protect operators working near the robot, be sure to connect the interlock switch and make sure that it works properly.
- The time to stop the robot and the stopping distance by the safeguard interlock function will change depending on the conditions of use. Be sure to confirm that safety is ensured according to the installation environment of the robot.

Stopping distance when the safeguard is opened

The Manipulator in operation cannot stop immediately after the safeguard is opened. In addition, stopping time and stopping distance vary by following factors:

- Hand weight WEIGHT Setting ACCEL Setting
- Workpiece weight SPEED Setting Posture etc.

For stopping time and stopping distance of the Manipulator, refer to “*Appendix C: Stopping Time and Stopping Distance When the Safeguard is Opened*”.

1.6 Emergency Movement Without Drive Power

When the system is placed in emergency mode, push the arm or joint of the Manipulator by hand as shown below:

Arm #1 Push the arm by hand.

Arm #2 Push the arm by hand.

Joint #3 The joint cannot be moved up/down by hand until the electromagnetic brake applied to the joint has been released.
Move the joint up/down while pressing the brake release switch.

Joint #4 Rotate the shaft by hand.

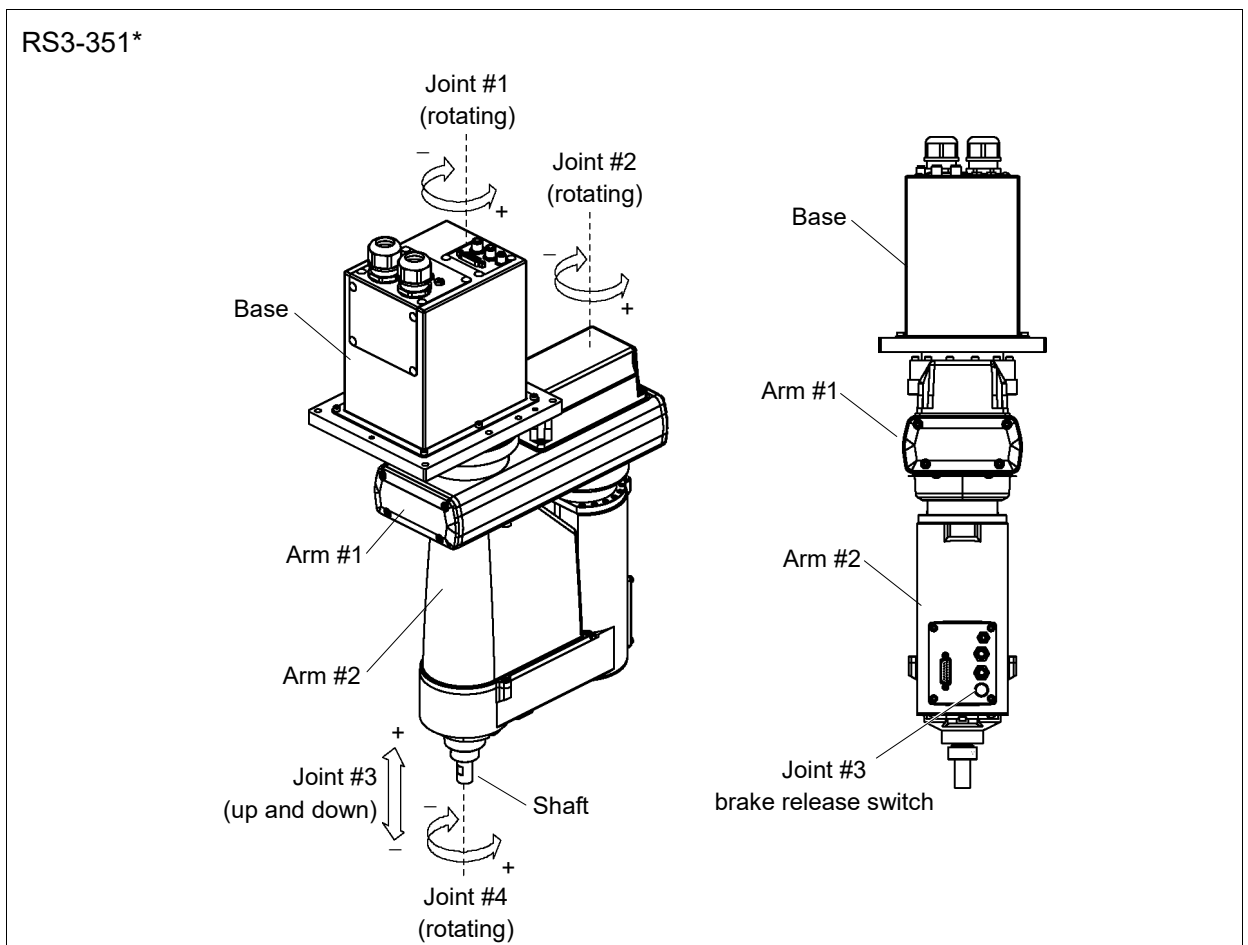

NOTE



Be careful of the shaft while the brake release switch is pressed, because the shaft may be lowered by the weight of an end effector.

RS4-551*

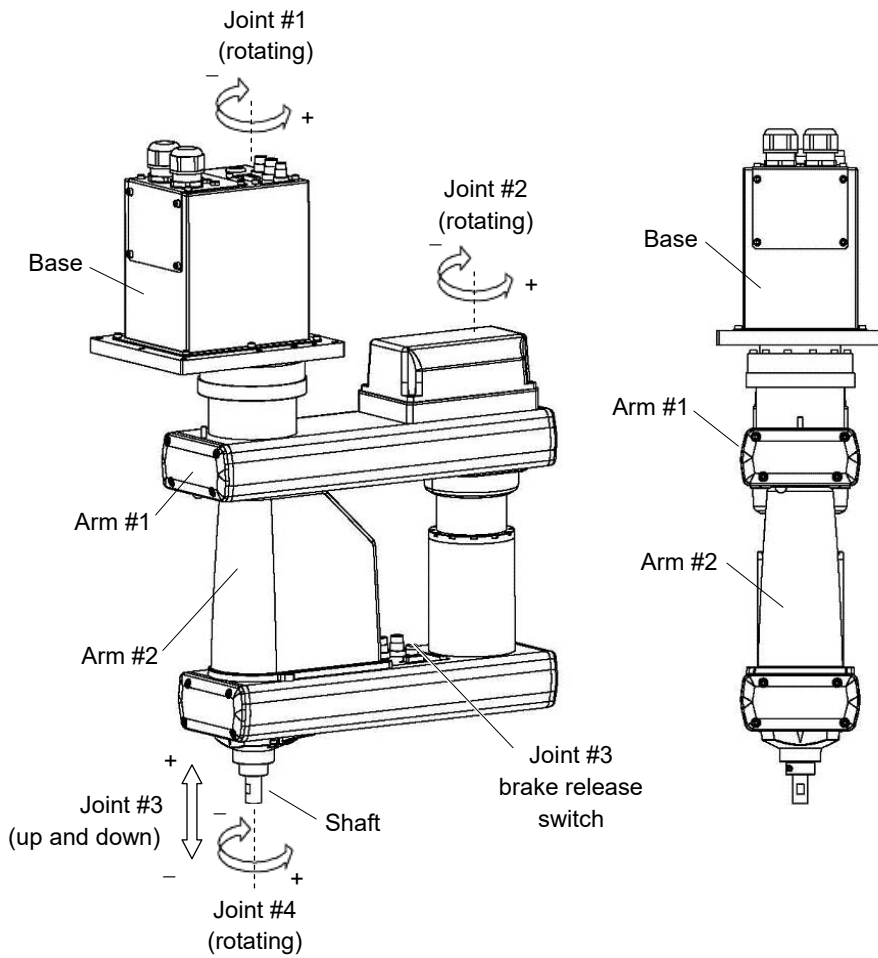

NOTE

Be careful of the shaft while the brake release switch is pressed, because the shaft may be lowered by the weight of an end effector.

1.7 ACCELS Setting for CP Motions

To make the Manipulator move in CP motion, see the following and set ACCELS properly according to the tip load and the Z-axis height.

NOTE Improper setting may cause following problems.
 Reduction of the life and damage of the ball screw spline

Set ACCELS as follows according to the Z-axis height.

ACCELS setting value by Z-axis position and tip load

RS3

Z position (mm)	Tip load		
	1kg or less	2kg or less	3kg or less
- 0 > Z >= - 50	25000 or less	25000 or less	24000 or less
-50 > Z >= - 100		24000 or less	16000 or less
- 100 > Z >= - 130		20000 or less	13000 or less

RS4

Z position (mm)	Tip load			
	1kg or less	2kg or less	3kg or less	4kg or less
- 0 > Z >= - 50	25000 or less	25000 or less	24000 or less	17000 or less
- 50 > Z >= - 100		24000 or less	16000 or less	12000 or less
- 100 > Z >= - 130		20000 or less	13000 or less	1000 or less

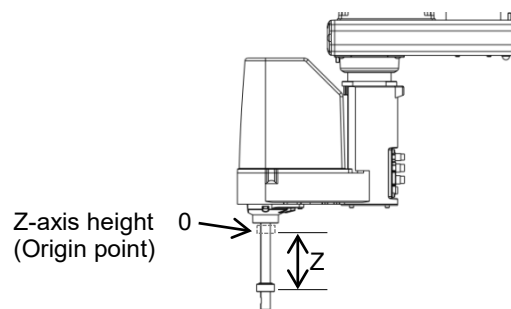

If the Manipulator is operated in CP motion with the wrong set values, make sure to check the following point.







Whether the ball screw spline shaft is deformed or bent



1.8 Warning Labels

The Manipulator has the following warning labels.

The warning labels are attached around the locations where specific dangers exist. Be sure to comply with descriptions and warnings on the labels to operate and maintain the Manipulator safely.

Do not tear, damage, or remove the warning labels. Use meticulous care when handling those parts or units to which the following warning labels are attached as well as the nearby areas.

Location	Warning Label	NOTE
A	 <div data-bbox="475 629 683 808"> <p>警告 WARNING 警告 AVERTISSEMENT 警告 ADVERTENCIA 경고 ATENÇÃO ОСТОПЖНО</p> <p>当心落下 当心落下 転倒の危険 転倒 위험 ОПАСНОСТЬ ОТРОИДЫВАНИЯ</p> <p>TIP-OVER HAZARD RISQUE DE BASCULEMENT PELIGRO DE VUELCO PERIGO DE QUEDA</p> </div>  <div data-bbox="308 824 571 1077"> <p>警告 在卸下底座安裝螺栓之前，請採取措施防止機械手掉落。 警告 在卸下底座安裝螺栓之前，請採取措施防止機械手掉落。 WARNING Take measures to prevent the manipulator from falling and tipping before removing base mounting bolts. AVERTISSEMENT Prendre les mesures nécessaires pour empêcher le manipulateur de tomber avant de démonter les vis de fixation de base. ADVERTENCIA Tome medidas para evitar que el manipulador se caiga antes de retirar los pernos de montaje de la base. ATENÇÃO Tome medidas para evitar que o manipulador caia antes de remover os parafusos de montagem de base. ОСТОПЖНО Перед снятием болтов крепления основания примите меры для предотвращения падения и падения Manipulatoa. 경고 이 작업 중 기계가 떨어지거나 도망치기 전에 꼭 확인하십시오. 警告 必ず取り外しが終わる前に、マニピュレータの落下防止対策を行ってください。</p> </div>	<p>Before loosening the base mounting screws, hold the arm and secure it tightly with a band to prevent hands or fingers from being caught in the Manipulator.</p>
B	 <div data-bbox="375 1099 603 1279"> <p>警告 WARNING 警告 AVERTISSEMENT 警告 ADVERTENCIA 경고 ATENÇÃO ОСТОПЖНО</p> <p>当心碰撞 当心碰撞 衝突の危険 충돌 위험 ОПАСНОСТЬ СТОЛКНОВЕНИЯ</p> <p>COLLISION HAZARD RISQUE DE COLLISION PELIGRO DE COLLISION PERIGO DE MORTE OU FERIMENTOS GRAVES</p> </div>  <div data-bbox="308 1294 571 1556"> <p>警告 移動時、機械臂可能会導致死亡或重傷。請勿進入工作區域。 警告 移動時、機械臂可能會導致人員死亡或重傷。請勿進入工作區域。 WARNING When moving, robot arm can cause death or serious injury. Do not enter work envelope. AVERTISSEMENT En se déplaçant, le bras du robot peut provoquer des blessures graves ou mortelles. Ne pas pénétrer dans l'enveloppe de travail. ADVERTENCIA Cuando se mueve, el brazo del robot puede causar la muerte o lesiones graves. No entre en el sobre de trabajo. ATENÇÃO Ao se mover, o braço do robô pode causar morte ou ferimentos graves. Não entre na área de trabalho. ОСТОПЖНО При движении рука робота может стать причиной смерти или серьезной травмы. Не входите в рабочий конверт. 경고 이 작업 중 움직이면 사망 또는 중상의 가능성이 있습니다. 작업 영역에 들어가지 마십시오. 警告 マニピュレータ稼働中は、絶対に動作エリアに入らないでください。アームに衝突する可能性があります。</p> </div>	<p>Do not enter the work space when the Manipulator is operating. It is extremely hazardous since the Arm may collide and cause serious safety problems,</p>
C	 <div data-bbox="359 1579 603 1765"> <p>警告 WARNING 警告 AVERTISSEMENT 警告 ADVERTENCIA 경고 ATENÇÃO ОСТОПЖНО</p> <p>当心触电 当心触电 帯電の危険 대전 위험 ОПАСНОСТЬ ПОЖАРЕНИЯ ЭЛЕКТРИЧЕСКИМ ТОКОМ</p> <p>ELECTRIC SHOCK HAZARD RISQUE DE CHOC ÉLECTRIQUE PELIGRO DE DESCARGA ELÉCTRICA</p> </div>  <div data-bbox="308 1780 534 1989"> <p>警告 WARNING 警告 AVERTISSEMENT 警告 ADVERTENCIA 경고 ATENÇÃO ОСТОПЖНО</p> <p>当心高温表面 当心高温表面 熱い表面 고온 표면 ГОРЯЧАЯ ПОВЕРХНОСТЬ</p> <p>HOT SURFACE SURFACE CHAUDE SUPERFICIE CALIENTE SUPERFÍCIE QUENTE ГОРЯЧАЯ ПОВЕРХНОСТЬ</p> </div>	<p>Hazardous voltage exists while the Manipulator is ON. To avoid electric shock, do not touch any internal electric parts.</p>

Location	Warning Label	NOTE
D		<p>You can catch your hand or fingers between the shaft and Arm #1 when bringing your hand close to moving parts.</p>
E		<p>Be careful of the hand falling and rotation while the brake release switch is being pressed.</p>
F		<p>Only authorized personnel should perform sling work and operate a crane and a forklift. When these operations are performed by unauthorized personnel, it is extremely hazardous and may result in serious bodily injury and/or severe equipment damage to the robot system. (only UL model.)</p>
Location	Label	Label
1	—	<p>Indicates Product name, Model name, Manipulator's serial No., Local codes information, Specification, Manufacturer, Importer, Date of manufacture, Country of manufacture, etc. For details, refer to the attached label.</p>

Location of Labels

RS3

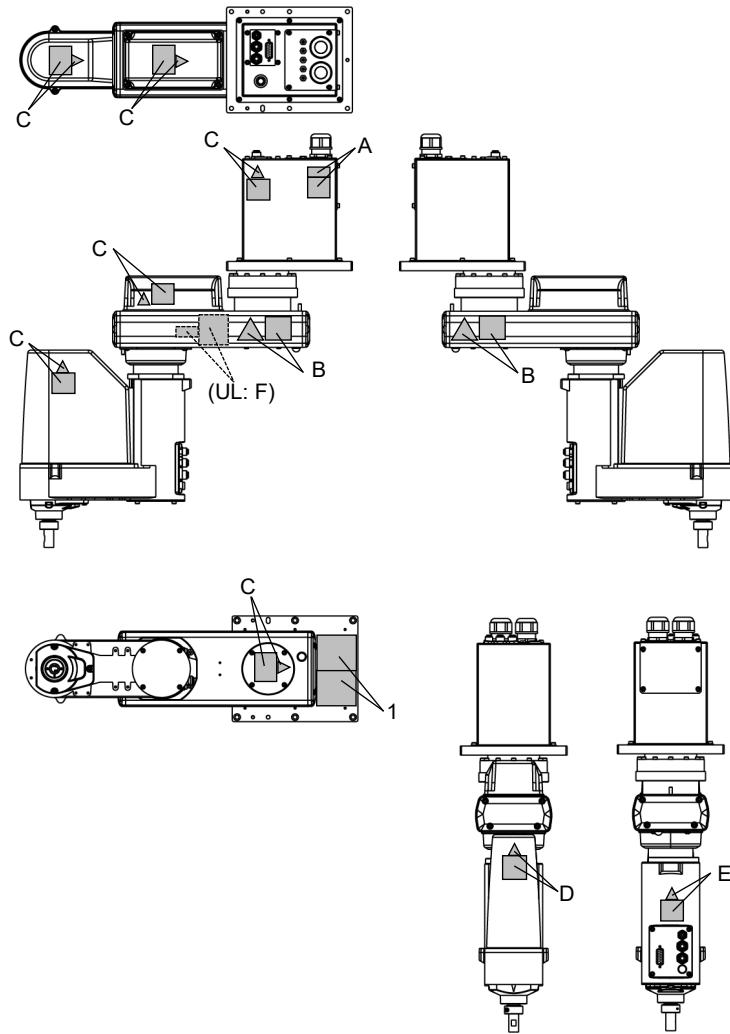

RS4

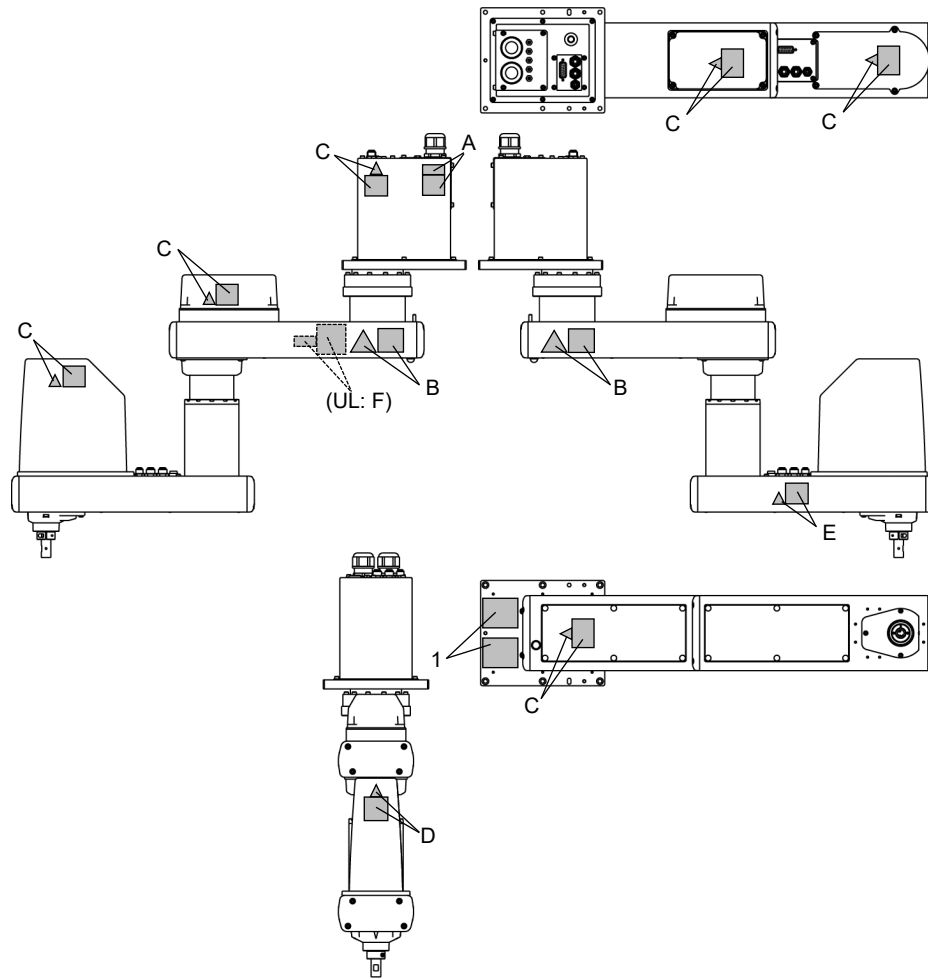

1.9 Response for Emergency or Malfunction

1.9.1 Collision

When the Manipulator collides with a mechanical stopper or peripheral device etc., discontinue use and contact the supplier.

Also, if the Manipulator collides with mechanical stops or peripheral devices, the following problems may occur.

- Reduction of the life and damage of the reduction gear unit
- Position gap at the joints

1.9.2 Getting body caught in Manipulator

When the operator is caught between the Manipulator and a mechanical part such as a base table, press the emergency stop switch to release the brake on the subject arm, and then move the arm by hand.

Get body caught in the arms:

The brake is not working. Move the arms manually.

Get body caught in the shafts:

The brake is working. Press the break release switch and move the shafts.

RS3-351*

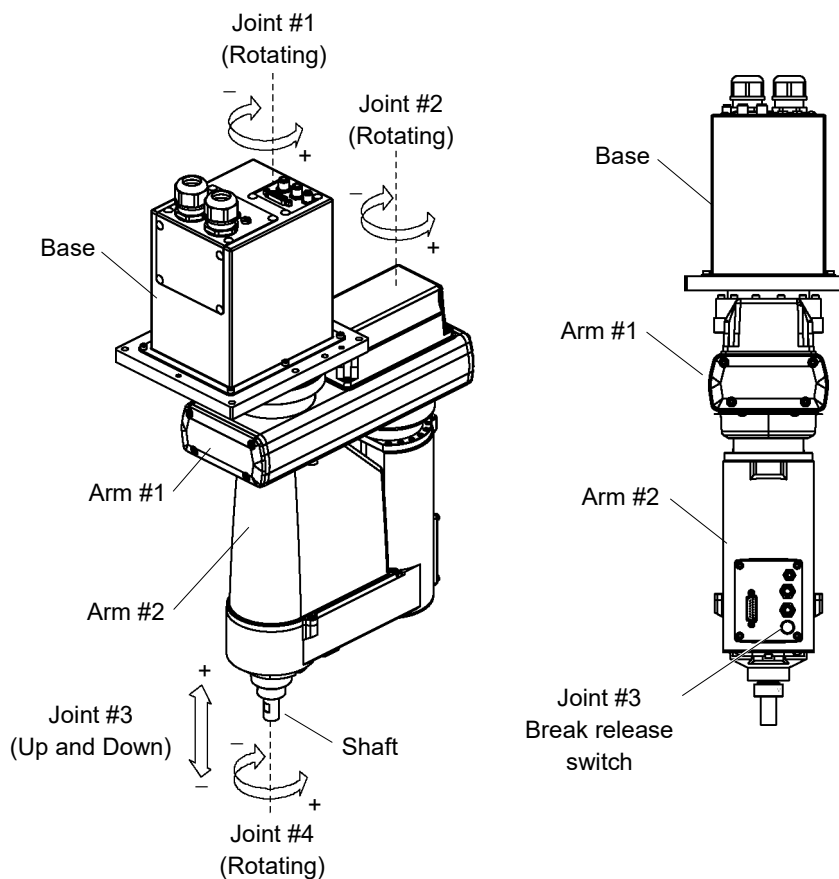

CAUTION

- While pressing the break release switch, not only Joint #3 but also Joint #4 may move due to its own weight. Be careful of the shaft falling or rotating.

2. Specifications

2.1 Model Number

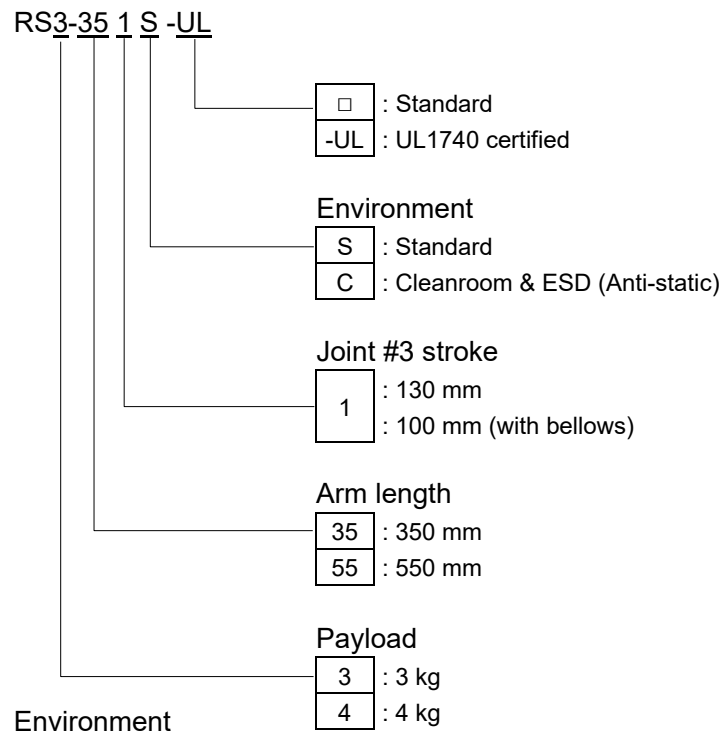

Cleanroom-model

This model has additional features that reduce dust emitted by the Manipulator to enable use in clean room environments.

For details of the specifications, refer to *Appendix A: Specifications*.

2.2 Part Names and Outer Dimensions

2.2.1 RS3-351*

Standard-model (RS3-351S)

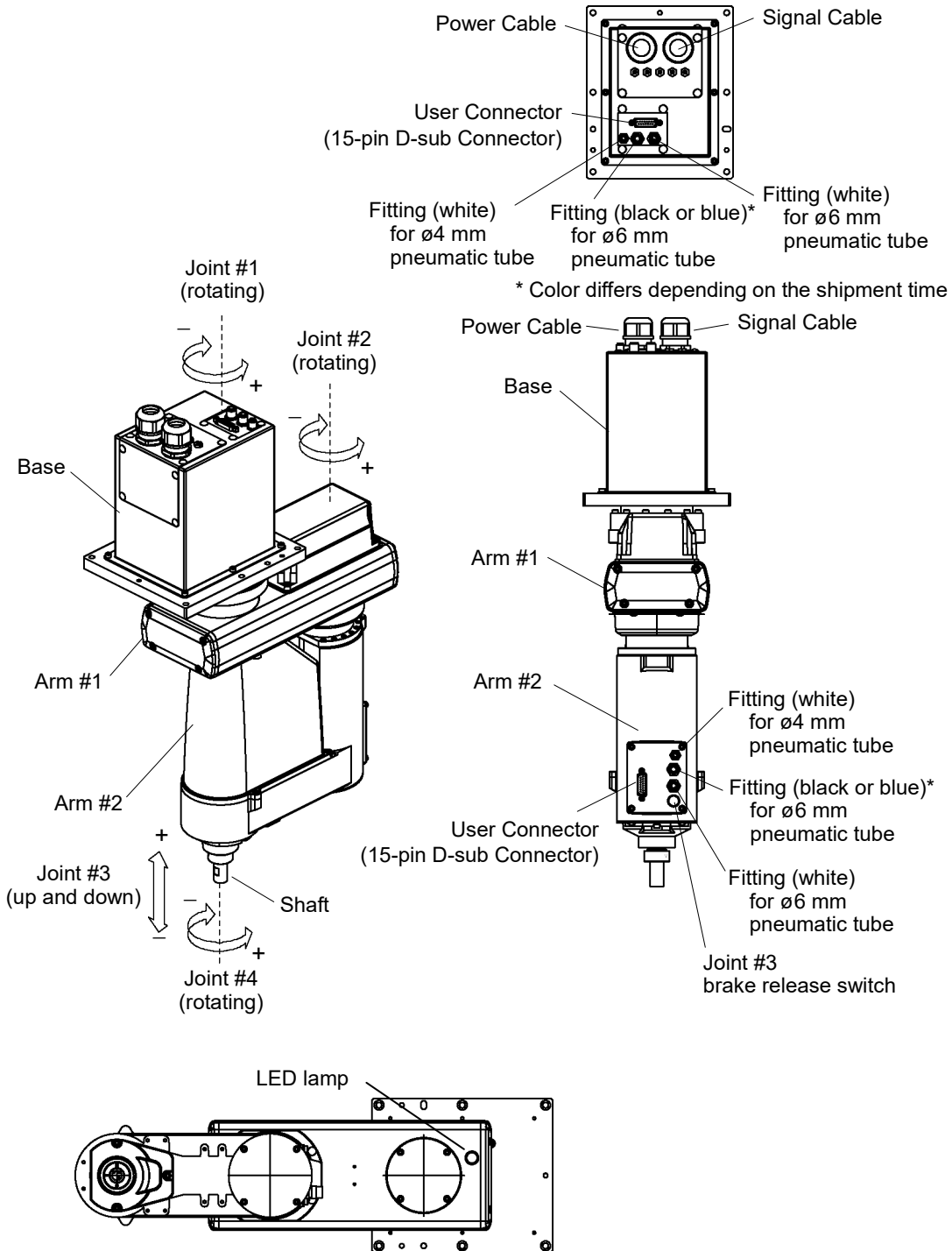

- When the brake release switch is pressed in emergency mode, the Joints #3 brake will be released.
- When the LED lamp is lighting or the controller power is on, the current is being applied to the manipulator. Performing any work with the power ON is extremely hazardous and it may result in electric shock and/or improper function of the robot system. Make sure to turn OFF the controller power before the maintenance work.

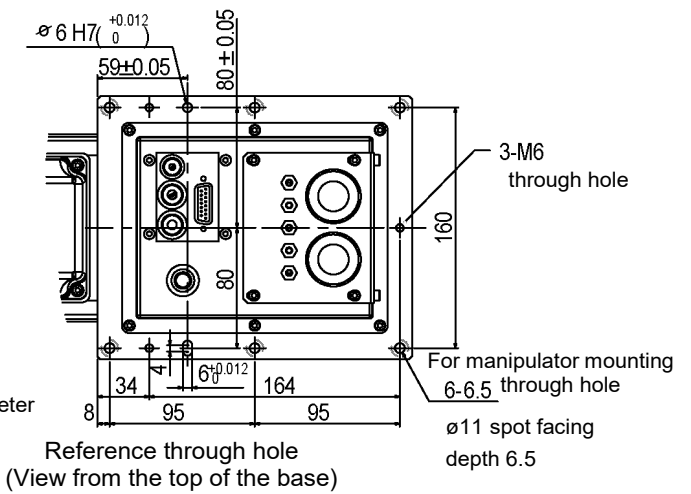
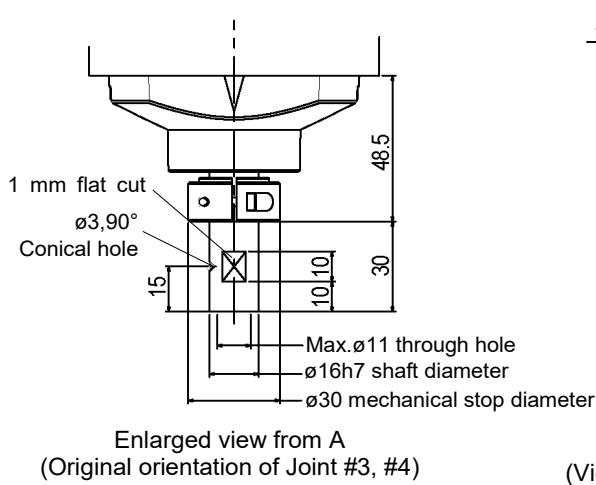
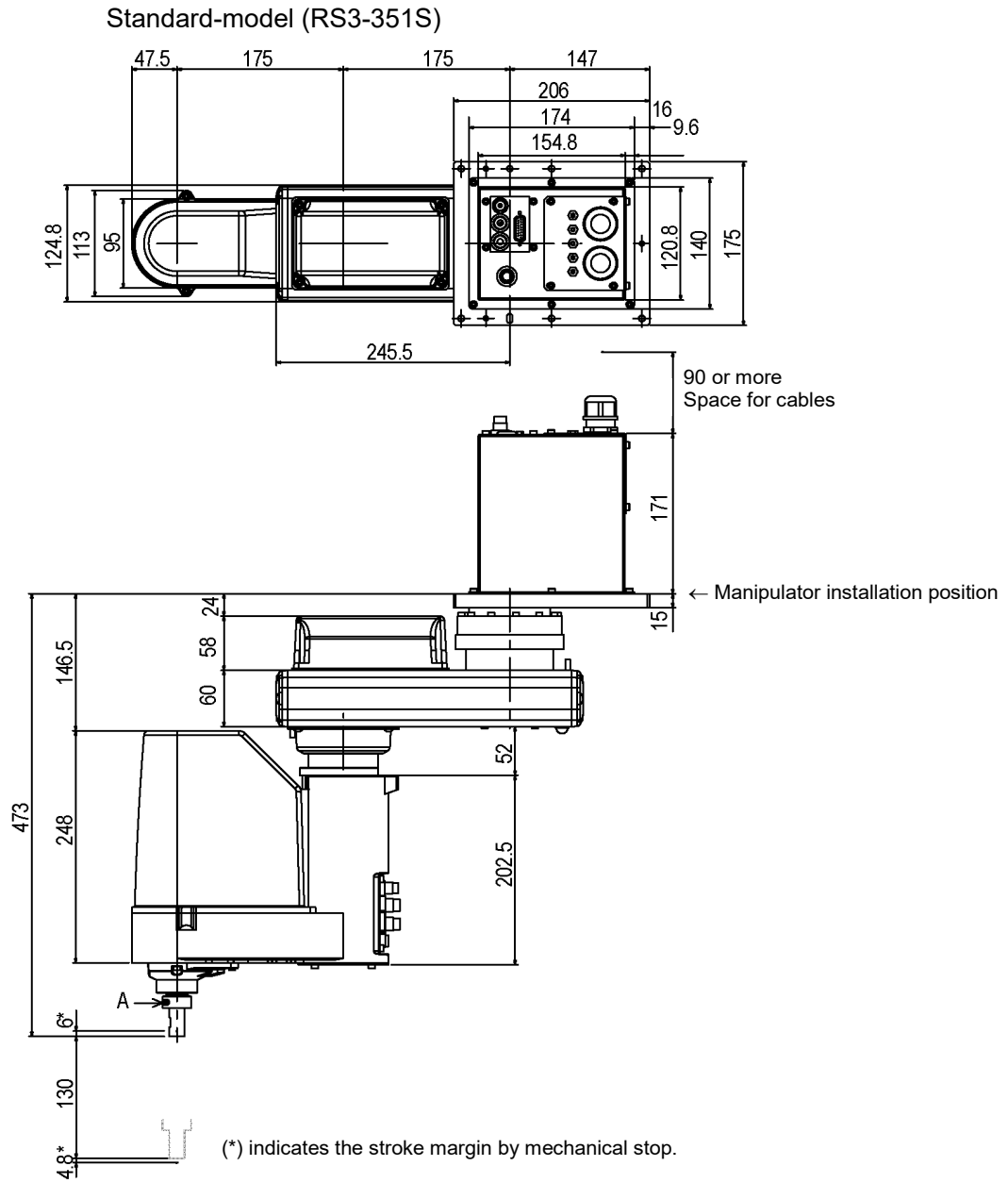

Cleanroom-model (RS3-351C)

The following figures show the special parts for Cleanroom-model.
These parts are different in appearance from Standard-model.

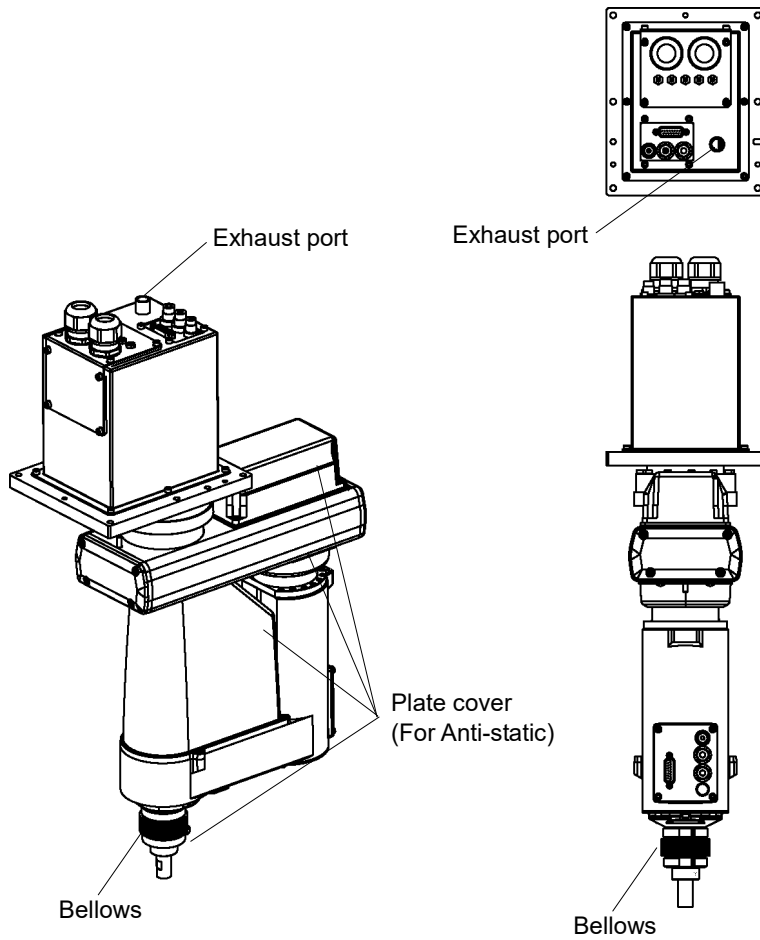

Cleanroom-model (RS3-351C)

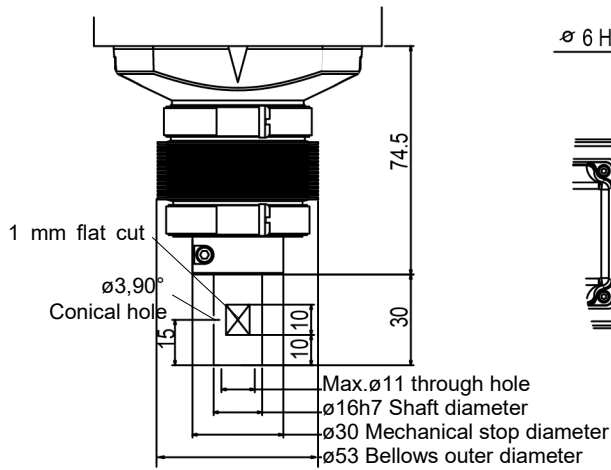
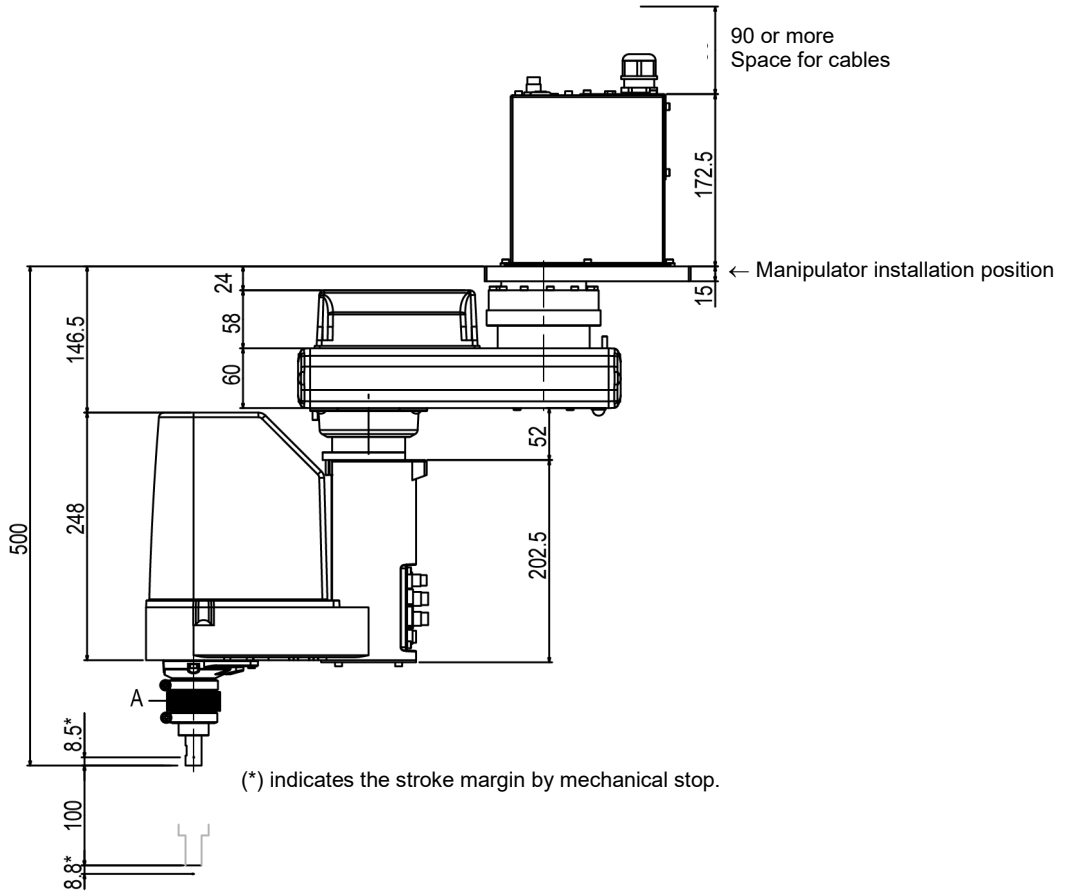
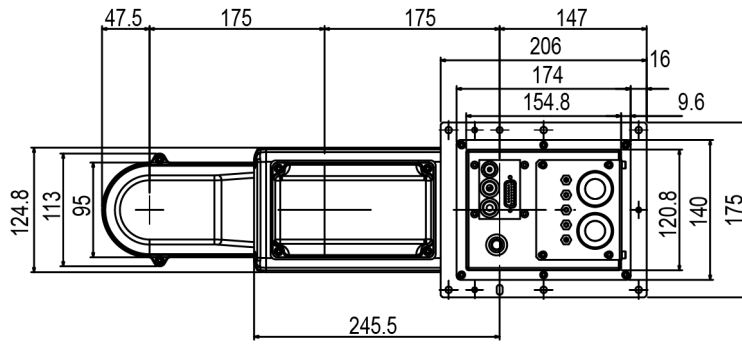

Enlarged view from A
(Original orientation of Joint #3, #4)

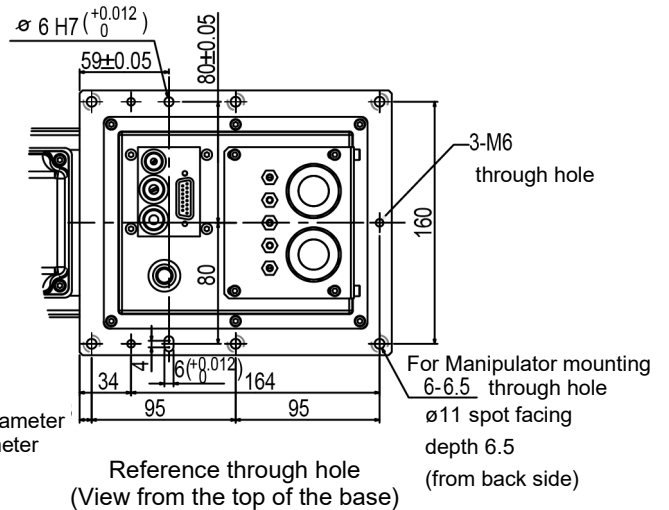

Reference through hole
(View from the top of the base)

2.3.2 RS4-551*

Standard-model (RS4-551S)

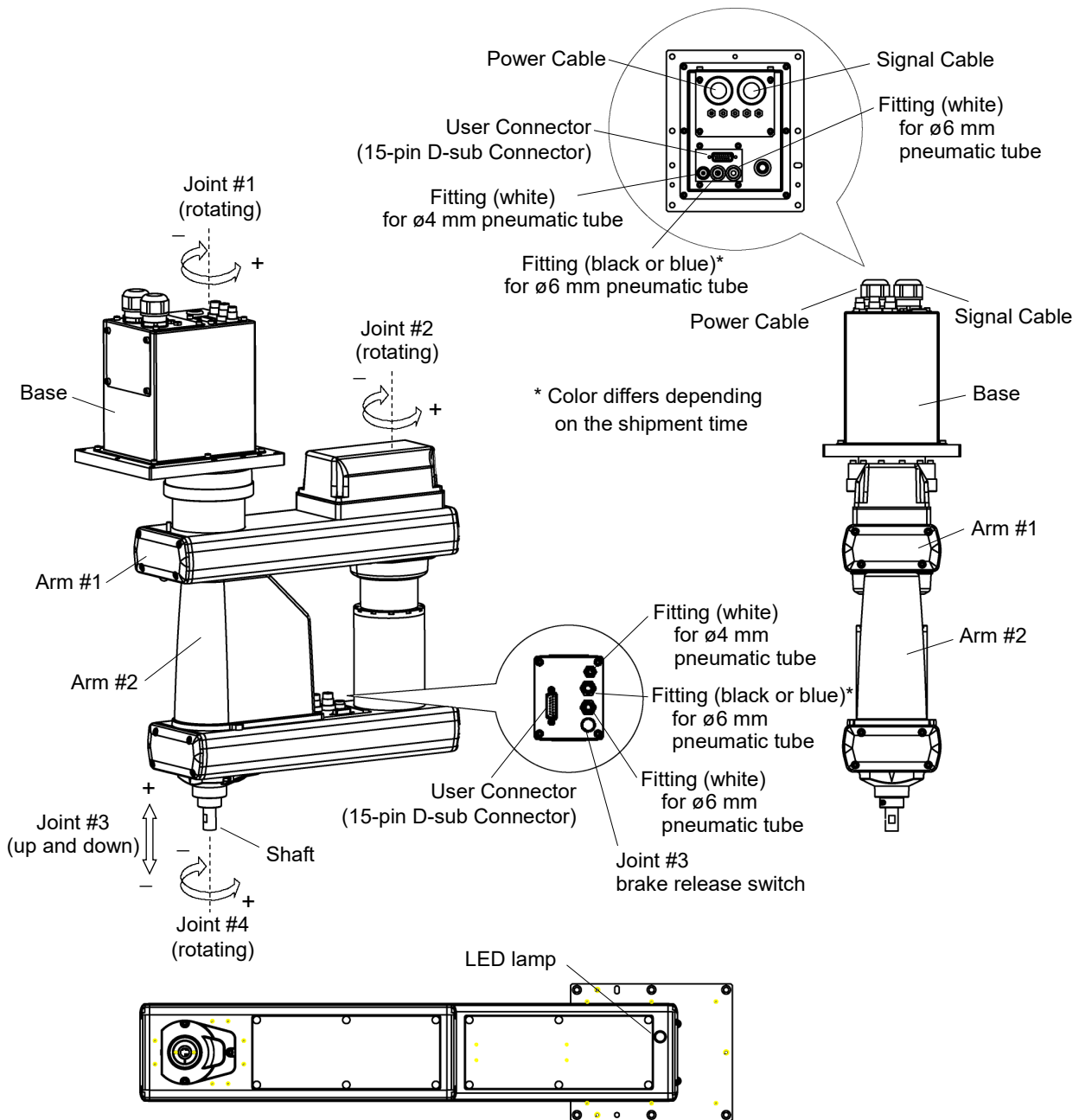

Standard-model (RS4-551S)

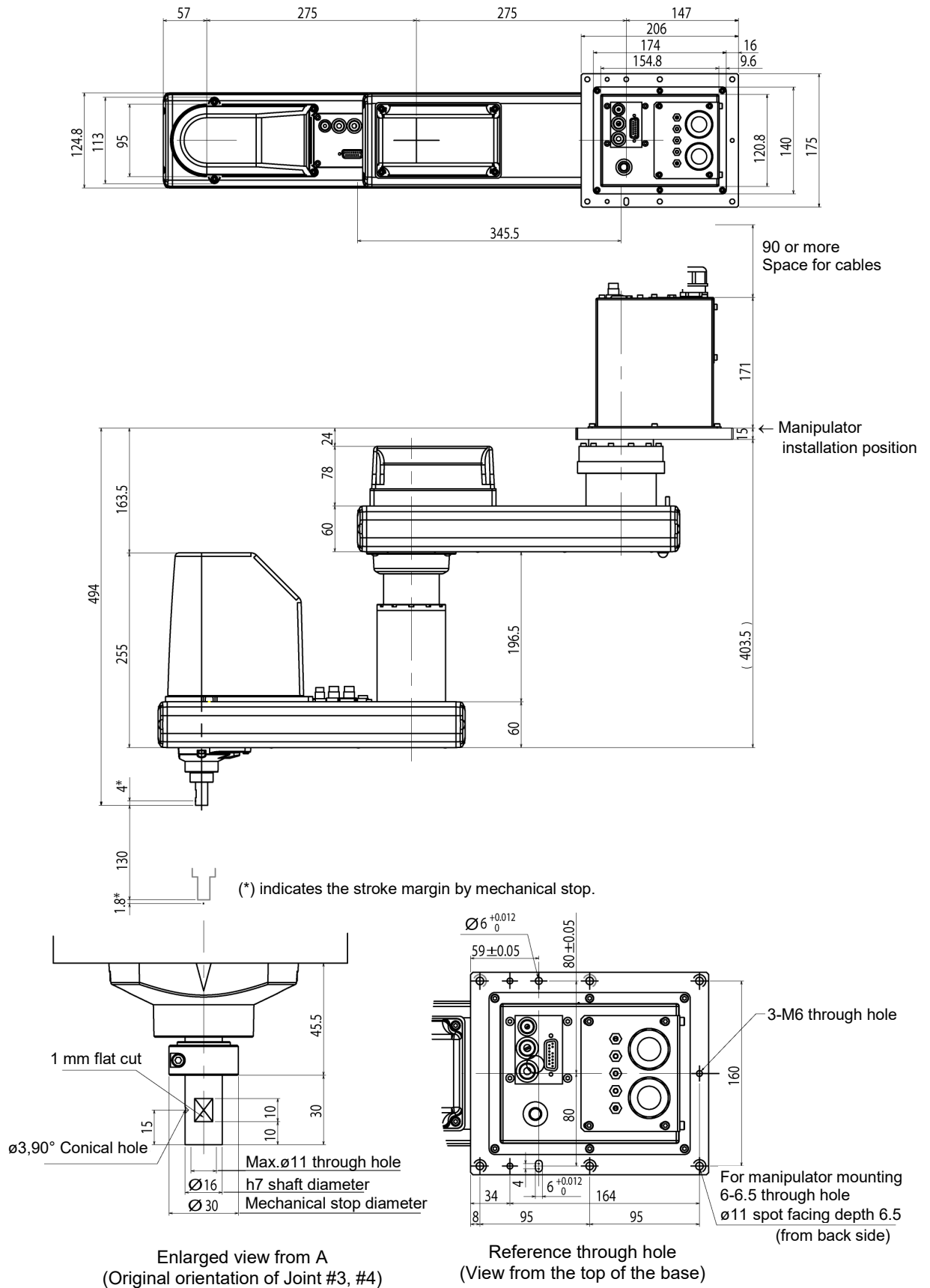

Cleanroom-model (RS4-551C)

The following figures show the special parts for Cleanroom-model.
These parts are different in appearance from Standard-model.

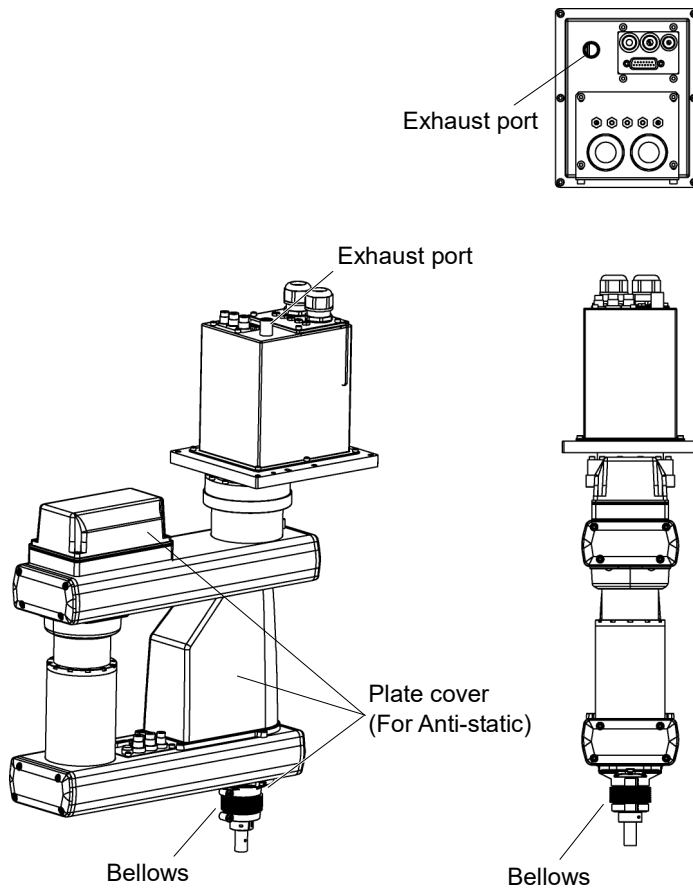

Cleanroom-model (RS4-551C)

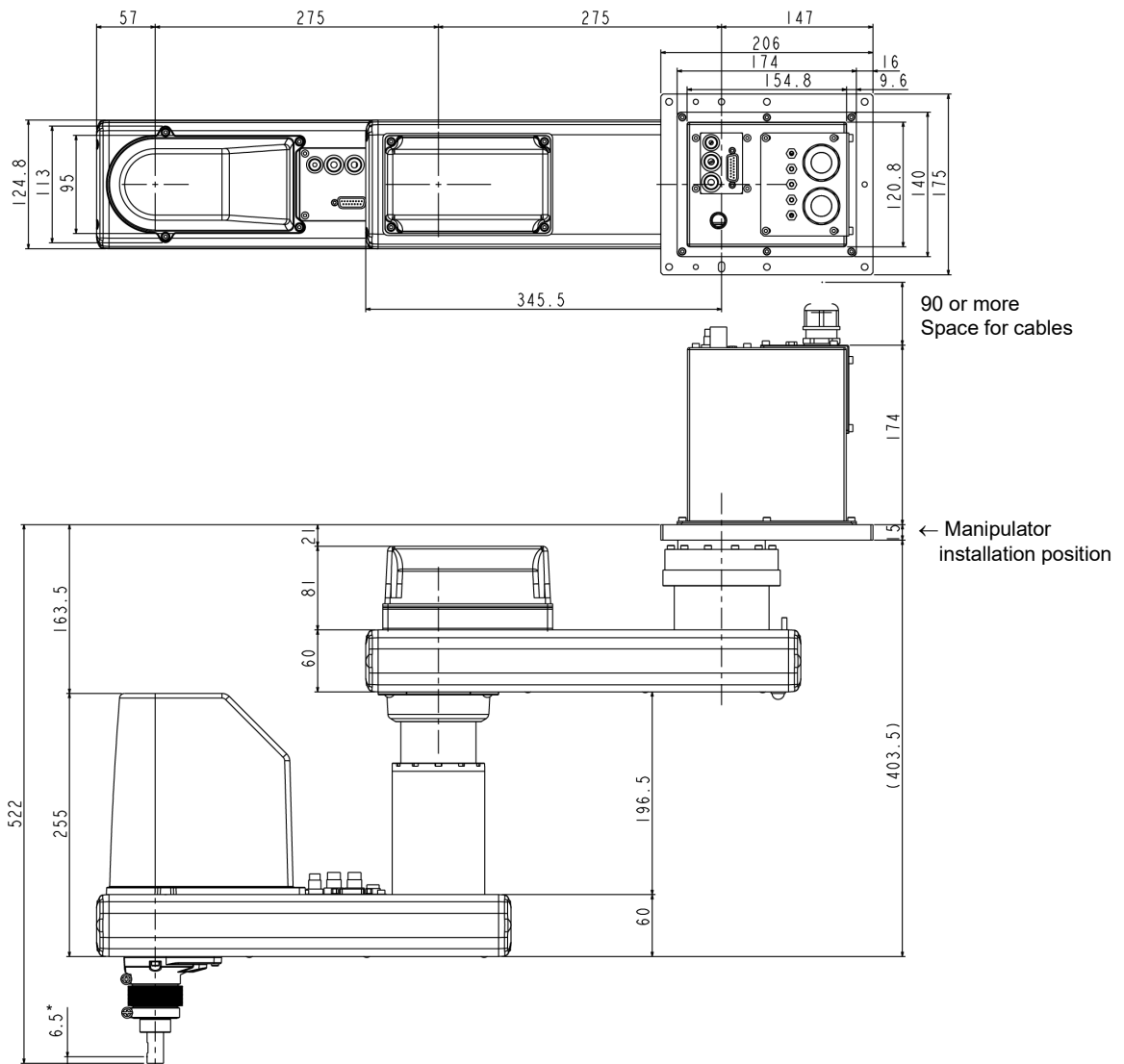

(*) indicates the stroke margin by mechanical stop.

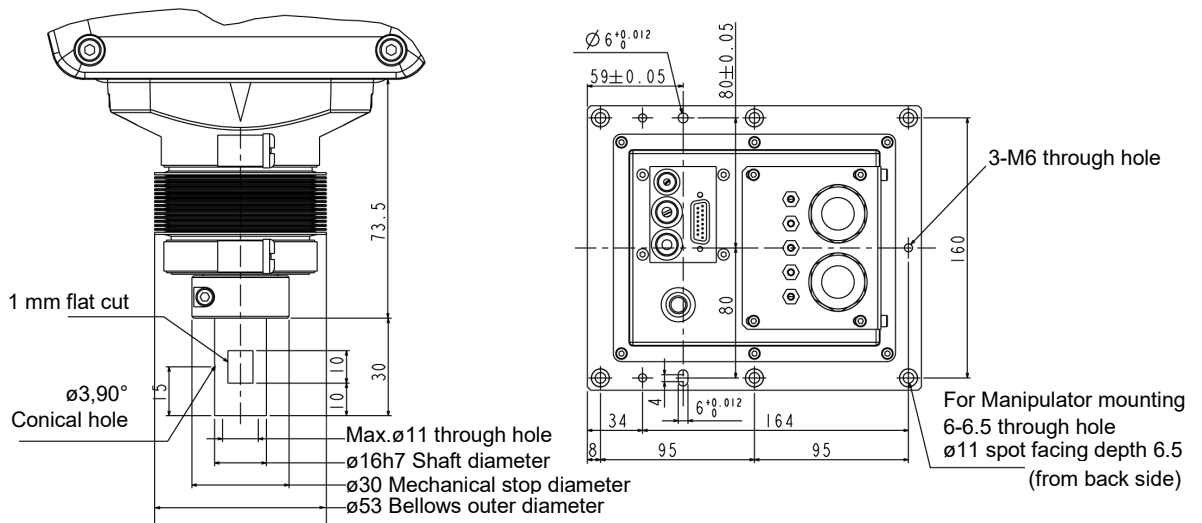

Enlarged view from A (Original orientation of Joint #3, #4)

Reference through hole (View from the top of the base)

2.3 Specifications

For details of each manipulator specifications, refer to *Appendix A: Specifications*.

2.4 How to Set the Model

The Manipulator model for your system has been set before shipment from the factory. It is normally not required to change the model when you receive your system.



- When you need to change the setting of the Manipulator model, be sure to set the Manipulator model properly. Improper setting of the Manipulator model may result in abnormal or no operation of the Manipulator and/or cause safety problems.



NOTE If the custom specifications number (MT*** or X***) is described on the signature label (S/N label), the Manipulator has custom specifications. (A label with only the custom specifications number may be attached depending on shipment time.)

The custom specifications may require a different configuration procedure; check the custom specifications number and contact the supplier of your region when necessary.

The Manipulator model can be set from software.

Refer to the chapter *Robot Configuration* in the *Epson RC+ User's Guide*.

3. Environments and Installation

Designing and installation of the Manipulators and robotic equipment shall be performed by personnel who has taken robot system training held by us and suppliers and should conform to all national and local codes.

3.1 Environmental Conditions

A suitable environment is necessary for the robot system to function properly and safely. Be sure to install the robot system in an environment that meets the following conditions:

Item	Conditions
Ambient temperature *1	5 to 40°C
Ambient relative humidity	10 to 80% (no condensation)
Fast transient burst noise	1 kV or less (Signal wire)
Electrostatic noise	4 kV or less
Altitude	1000 m or lower
Environment	<ul style="list-style-type: none"> - Install indoors. - Keep away from direct sunlight. - Keep away from dust, oily smoke, salinity, metal powder or other contaminants - Keep away from flammable or corrosive solvents and gases - Keep away from water and oil. - Keep away from shocks or vibrations. - Keep away from sources of electric noise. - Keep away from explosive area - Keep away from a large quantity of radiation



Manipulators are not suitable for operation in harsh environments such as painting areas, etc. When using Manipulators in inadequate environments that do not meet the above conditions, please contact the supplier of your region.

*1 The ambient temperature conditions are for the Manipulators only. For the Controller the Manipulators are connected to, refer to the Controller manual.

When the product is used in a low temperature environment around the minimum temperature of the product specification, or when the product is suspended for a long time on holidays or at night, a collision detection error may occur due to the large resistance of the drive unit immediately after the start of operation. In such a case, it is recommended to warm up for about 10 minutes.

Special Environmental Conditions

The surface of the Manipulator has general oil resistance. However, if your requirements specify that the Manipulator must withstand certain kinds of oil, please contact the supplier of your region.

Rapid change in temperature and humidity can cause condensation inside the Manipulator. If your requirements specify that the Manipulator handles food, please contact the supplier of your region to check whether the Manipulator will damage the food or not.

The Manipulator cannot be used in corrosive environments where acid or alkaline is used. In a salty environment where the rust is likely to gather, the Manipulator is susceptible to rust.

 WARNING	<ul style="list-style-type: none"> Use an earth leakage breaker on the AC power cable of the Controller to avoid electric shock and circuit breakdown caused by short circuit. Prepare the earth leakage breaker that pertains the Controller you are using. For details, refer to the Controller manual.
--	--

 CAUTION	<ul style="list-style-type: none"> When cleaning the Manipulator, do not rub it strongly with alcohol or benzene. It may lose luster on the coated face.
--	---

3.2 Base Table

A base table for anchoring the Manipulator is not supplied. Please make or obtain the base table for your Manipulator. The shape and size of the base table differs depending on the use of the robot system. For your reference, we list some Manipulator table requirements here.

The base table must not only be able to bear the weight of the Manipulator but also be able to withstand the dynamic movement of the Manipulator when the Manipulator operates at maximum acceleration/deceleration. Ensure that there is enough strength on the base table by attaching reinforcing materials such as crossbeams.

The torque and reaction force produced by the movement of the Manipulator are as follows:

- Max. Reaction torque on the horizontal plate : 500 Nm
- Max. Horizontal reaction force : 1200 N (RS3-351*)
- : 1400 N (RS4-551*)
- Max. Vertical reaction force : 1100 N

 CAUTION	<ul style="list-style-type: none"> If the vibration of the base table is large, reduce the acceleration/deceleration or increase the rigidity of the base table to reduce the vibration. Continued use in a state of large vibration may cause loosening of fastening parts or excessive load on mechanical parts, which may shorten the lifespan.
--	---

The threaded holes required for mounting the Manipulator base are M6. Use mounting bolts with specifications conforming to ISO898-1 property class: 10.9 or 12.9. For dimensions, refer to 3.3 *Mounting Dimensions*.

The plate for the Manipulator mounting face should be 20 mm thick or more and made of steel to reduce vibration. The surface roughness of the steel plate should be 25 μm or less.

The table must be secured on the floor or wall to prevent it from moving.

The Manipulator installation surface should have a flatness of 0.5 mm or less and an inclination of 0.5 ° or less. If the flatness of the installation surface is improper, the base may be damaged, or the robot may not fully show its performance.

When using a leveler to adjust the height of the base table, use a screw with M16 diameter or more.

If you are passing cables through the holes on the base table, see the figures below.

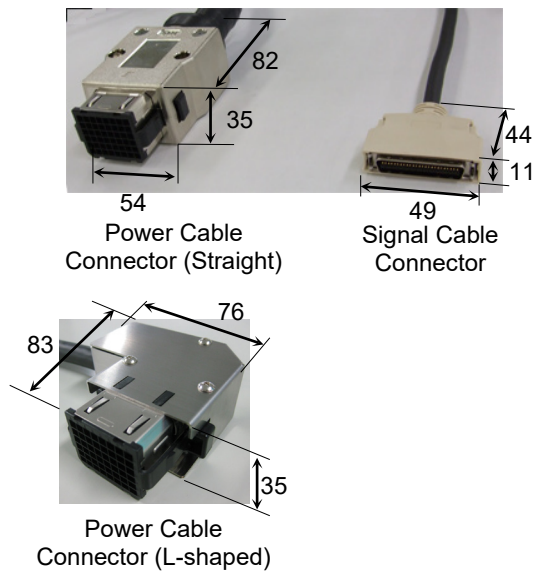
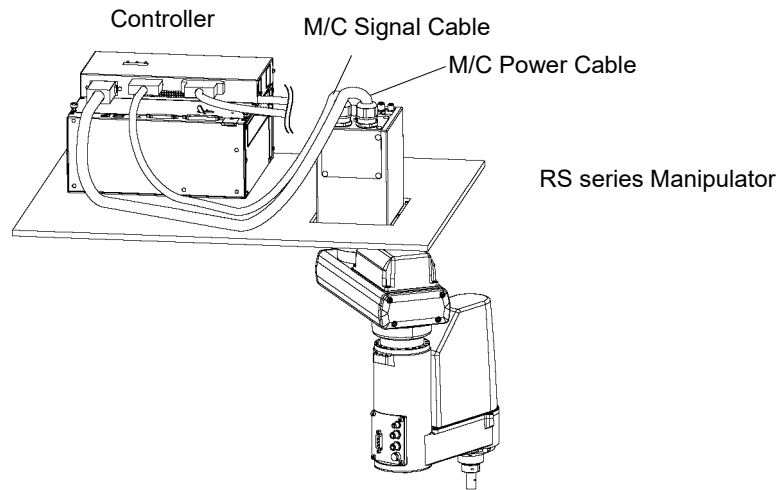

The M/C cables are installed to the Manipulator body and cannot be removed. Never try to remove the M/C cables.

In case that the base table has no maintenance window, it needs to remove the Manipulator from the base table for the maintenance. When designing the base table, consider this point.

NOTE For environmental conditions regarding space when placing the Controller on the base table, refer to the *Controller manual*.



WARNING
 ■ To ensure safety, a safeguard must be installed for the robot system.
 For details on the safeguard, refer to the Epson RC+ User's Guide.

Base Table – Design Example

The following is an example for designing the base table of RS3 Manipulator. During the operation of RS3 in the maximum acceleration/deceleration speed, the base table must be steady enough to prevent the vibration from transmitting to RS3.

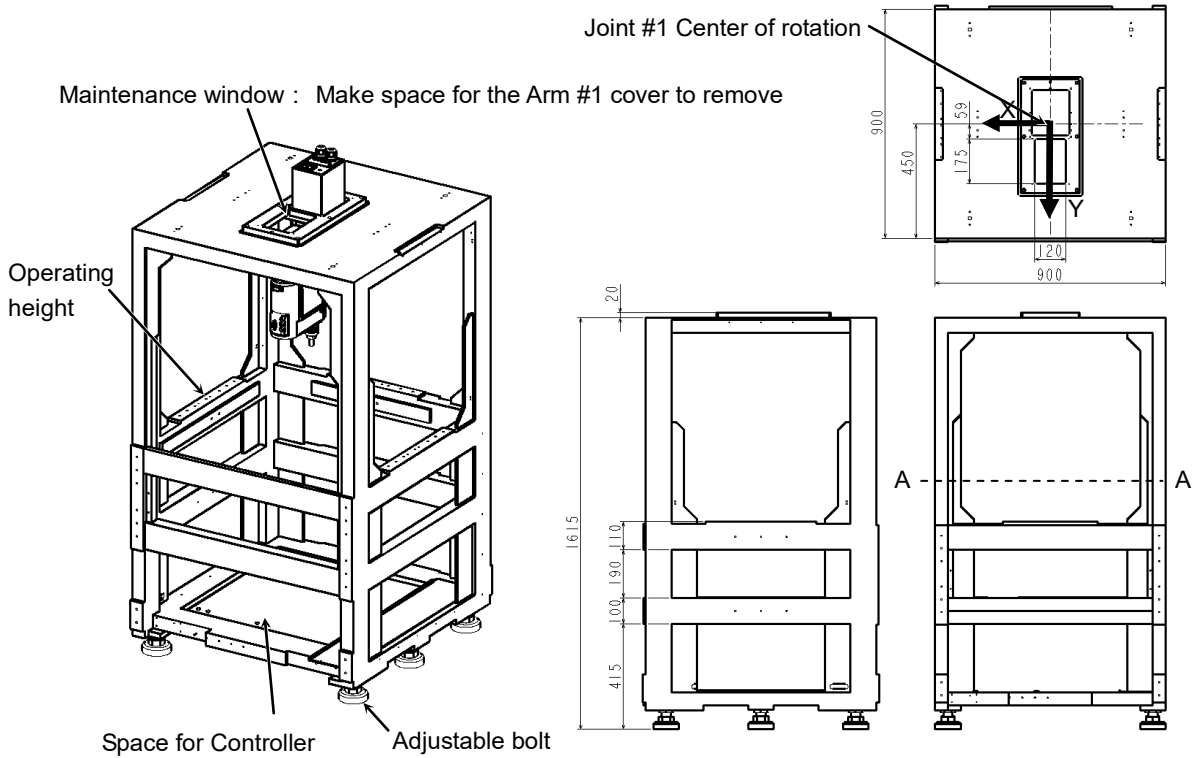

- Wight of table : approx. 300 kg
- Material for the flame : Iron pipe: □ 100 × 50 mm 3.2 mm thick
- Adjustable bolt : M36
- Geometrical moment of inertia : $I_x=1.2 \times 10^9 \text{ mm}^4$
- (A-A) $I_y=1.2 \times 10^9 \text{ mm}^4$

- Set low aspect ratio of the base table height and width
- Put center of gravity lower position by installing the Controller on the bottom of the base table.
- Reinforce the open part with joist or similar material to minimize the part.
- The condition depends on the table height, width, the position of joist, and the center of gravity.

3.3 Mounting Dimensions

The maximum space described in figures shows that the radius of the end effector is 50 mm or less. If the radius of the end effector exceeds 50 mm, define the radius as the distance to the outer edge of maximum space.

If a camera or electromagnetic valve extends outside of the arm, set the maximum range including the space that they may reach.

Be sure to allow for the following extra spaces in addition to the space required for mounting the Manipulator, Controller, and peripheral equipment.

Space for teaching

Space for maintenance and inspection

Ensure a space to open the cover for maintenance.

Space for cables

The minimum bend radius of the power cable is 90 mm. When installing the cable, be sure to maintain sufficient distance from obstacles. In addition, leave enough space for other cables so that they are not bent forcibly.

Ensure distance to the safeguard from the maximum motion range is more than 50 mm.

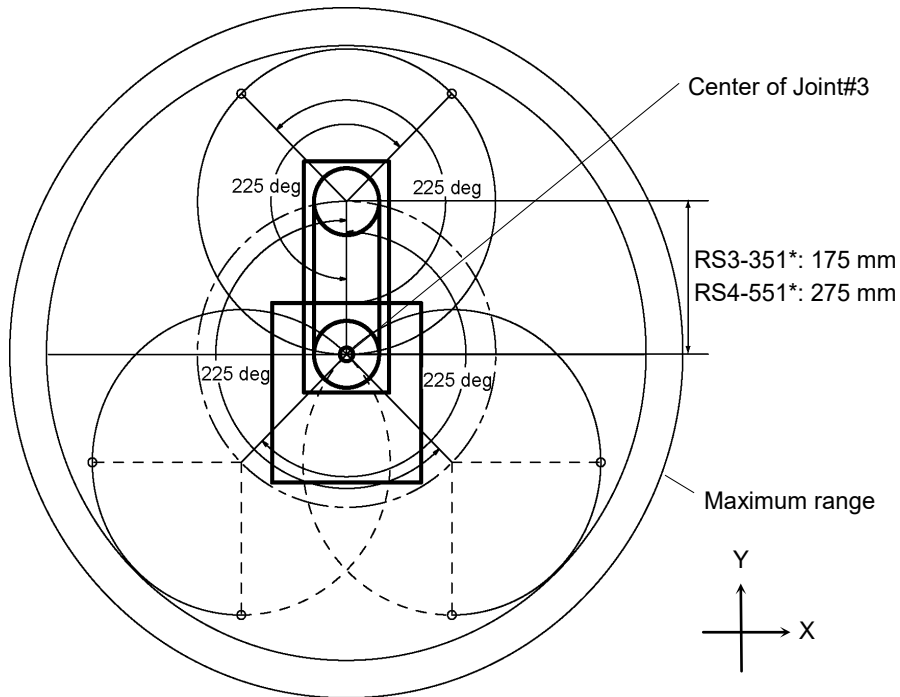

	RS3-351*	RS4-551*
Arm #1 Length	175 mm	275 mm
Arm #2 Length	175 mm	275 mm
Joint #1 Motion range	± 225 degree	
Joint #2 Motion range	± 225 degree	

3.4 Unpacking and Transportation

Transportation and installation of the Manipulators and robotic equipment shall be performed by personnel who has taken robot system training held by us and suppliers and should conform to all national and local codes.

 WARNING	<ul style="list-style-type: none"> Only authorized personnel should perform sling work and operate a crane and a forklift. When these operations are performed by unauthorized personnel, it is extremely hazardous and may result in serious bodily injury and/or severe equipment damage to the robot system.
--	--

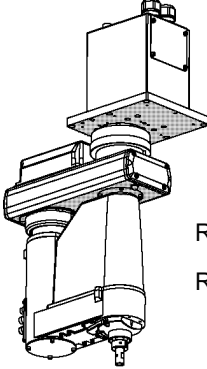
 CAUTION	<ul style="list-style-type: none"> Using a cart or similar equipment, transport the Manipulator in the same manner as it was delivered. After removing the bolts securing the Manipulator to the delivery equipment, the Manipulator can fall. Be careful not to get hands or fingers caught. The arm is secured with a wire tie. Leave the wire tie secured until you finish the installation so as not to get hands or fingers caught. To transport the Manipulator, have two or more people to work on it and secure the Manipulator to the delivery equipment or hold the areas indicated in gray in the figure (bottom of Arm #1 and bottom of the base) by hand. When holding the bottom of the base by hand, be very careful not to get your hands or fingers caught. <div style="text-align: center;">  <p>RS3-351* : approx. 17 kg : 38 lb. RS4-551* : approx. 19 kg : 42 lb.</p> </div> <ul style="list-style-type: none"> Stabilize the Manipulator with your hands when hoisting it. When transporting the Manipulator for a long distance, secure it to the delivery equipment directly so that the Manipulator never falls. If necessary, pack the Manipulator in the same style as it was delivered.
--	---

3.5 Installation

Installation of the Manipulators and robotic equipment shall be performed by personnel who has taken robot system training held by us and suppliers and should conform to all national and local codes.

 CAUTION	<ul style="list-style-type: none"> ■ The robot system must be installed to avoid interference with buildings, structures, utilities, other machines and equipment that may create a trapping hazard or pinch points. ■ Vibration (resonance) may occur during operation depending on rigidity of the installation table. If the oscillation occurs, improve rigidity of the table or change the speed or acceleration and deceleration settings.
--	--

3.5.1 Standard-model

 CAUTION	<ul style="list-style-type: none"> ■ Install the Manipulator with two or more people. The Manipulator weights are as follows. Be careful not to get hands, fingers, or feet caught and/or have equipment damaged by a fall of the Manipulator. RS3-351* : approx. 17 kg : 38 lb. (except cables) RS4-551* : approx. 19 kg : 42 lb. (except cables) ■ When installing the Manipulator to the ceiling, support the Manipulator, and then secure the anchor bolts. Removing the support without securing the anchor bolts properly is extremely hazardous and may result in fall of the Manipulator.
---	---

- (1) Unpack the Manipulator with retaining the arm posture.

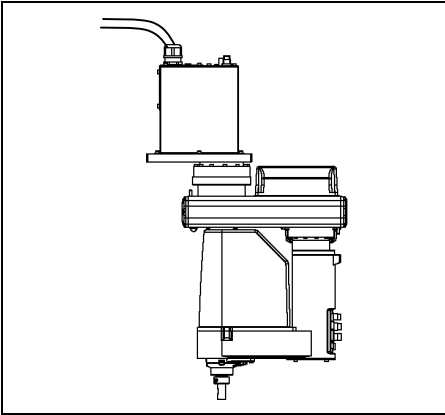

- (2) Secure the base to the wall with 6 bolts.



- NOTE
- RS3-351*: Remove the protective tape in advance.
 - Intensity of the bolts should be equivalent to ISO898-1 Property Class 10.9 or 12.9.

Tightening torque:

13.0 N·cm (133 kgf·cm)

- (3) Remove the fixing jig for transport.

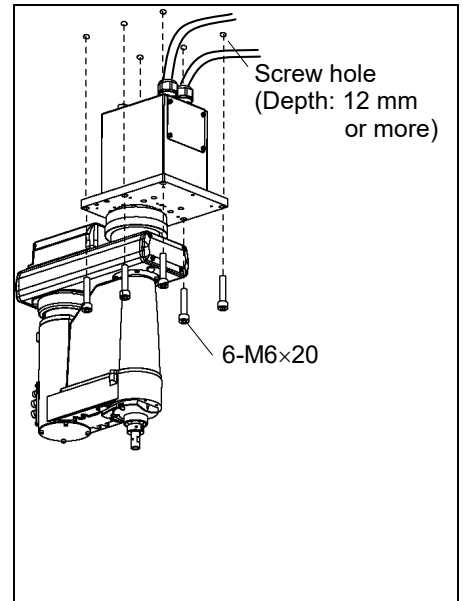

3.5.2 Cleanroom-model

- (1) Unpack the Manipulator outside of the clean room.
- (2) Secure the Manipulator to delivery equipment such as a pallet with bolts so that the Manipulator does not fall over.
- (3) Wipe off the dust on the Manipulator with a little alcohol or distilled water on a lint-free cloth.
- (4) Transport the Manipulator into the cleanroom.
- (5) Refer to the installation procedure of each Manipulator model and install the Manipulator.
- (6) Connect an exhaust tube to the exhaust port.

3.6 Connecting the Cables

 WARNING	<ul style="list-style-type: none"> ■ To shut off power to the robot system, disconnect the power plug from the power source. Be sure to connect the AC power cable to a power receptacle. DO NOT connect it directly to a factory power source. ■ Before performing any replacement procedure, turn OFF the Controller and related equipment, and then disconnect the power plug from the power source. Performing any replacement procedure with the power ON is extremely hazardous and may result in electric shock and/or malfunction of the robot system. ■ Be sure to connect the cables properly. Do not allow unnecessary strain on the cables. (Do not put heavy objects on the cables. Do not bend or pull the cables forcibly.) The unnecessary strain on the cables may result in damage to the cables, disconnection, and/or contact failure. Damaged cables, disconnection, or contact failure is extremely hazardous and may result in electric shock and/or improper function of the robot system. ■ Grounding the manipulator is done by connecting with the controller. Ensure that the controller is grounded and the cables are correctly connected. If the ground wire is improperly connected to ground, it may result in the fire or electric shock.
--	--

 CAUTION	<ul style="list-style-type: none"> ■ When connecting the Manipulator to the Controller, make sure that the serial numbers on each equipment match. Improper connection between the Manipulator and Controller may not only cause improper function of the robot system but also serious safety problems. The connection method varies with the Controller used. For details on the connection, refer to the <i>Controller manual</i>. If the Manipulator G series, E2 series or RS series is connected to the Controller for the 6-axis, it may result in malfunction of the Manipulator.
--	--

When the Manipulator is a Cleanroom-model, use it with an exhaust system.
 For details, refer to *Setup & Operation: 2.4 Specifications*.

Cable Connections

Connect the power connector and signal connector of the M/C cables to the Controller.

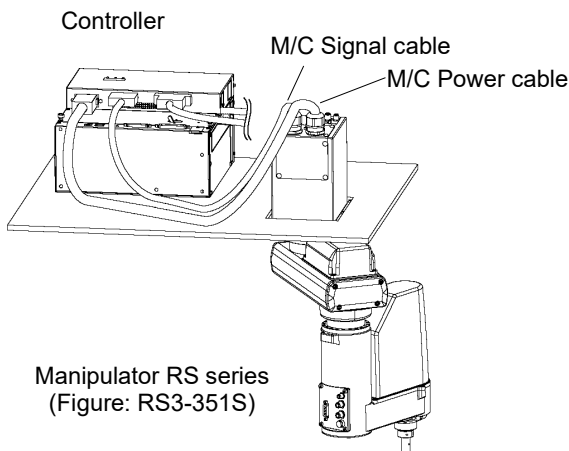

3.7 User Wires and Pneumatic Tubes

 CAUTION	<ul style="list-style-type: none"> Only authorized or certified personnel should be allowed to perform wiring. Wiring by unauthorized or uncertified personnel may result in bodily injury and/or malfunction of the robot system.
---	---

User electrical wires and pneumatic tubes are contained in the cable unit.

Electrical Wires

Rated Voltage	Allowable Current	Wires	Nominal Sectional Area	Outer Diameter	Note
AC/DC30 V	1 A	15	0.211 mm ²	ø8.3±0.3 mm	Shielded

		Maker	Standard
15 pin	Suitable Connector	JAE	DA-15PF-N (Solder type)
	Clamp Hood	JAE	DA-C8-J10-F2-1R (Connector setscrew: #4-40 NC)

Pins with the same number, indicated on the connectors on both ends of the cables, are connected.

Pneumatic Tubes

Max. Usable Pneumatic Pressure	Pneumatic Tubes	Outer Diameter × Inner Diameter
0.59 MPa (6 kgf/cm ² : 86 psi)	2	ø6 mm × ø4 mm
	1	ø4 mm × ø2.5 mm

Fittings for ø6 mm and ø4 mm (outer diameter) pneumatic tubes are supplied on both ends of the pneumatic tubes.

RS3-351*

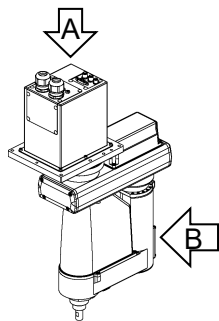

RS4-551*

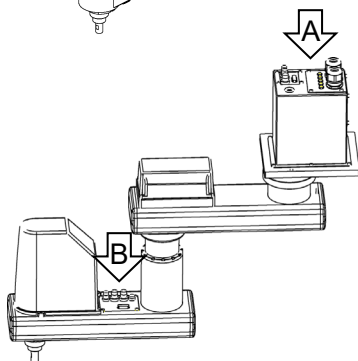

A

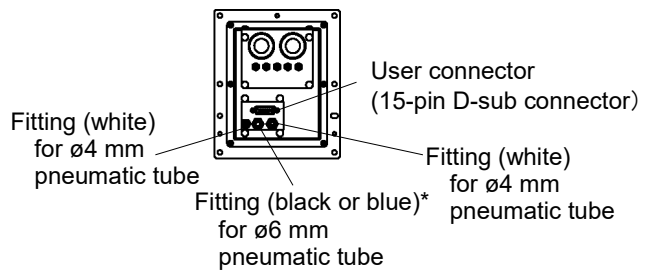

B

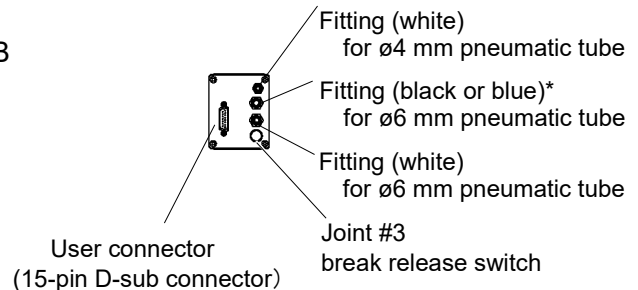

* Color differs depending on the shipment time





The Joint #4 (rotating) motion range is ±720 degrees. Be careful not to let the wires/tubes caught in the end effector.

3.8 Relocation and Storage

3.8.1 Precautions for Relocation and Storage

Observe the following when relocating, storing, and transporting the Manipulators. Transportation and installation of the Manipulators and robotic equipment shall be performed by personnel who has taken robot system training held by us and suppliers and should conform to all national and local codes.

 WARNING	<ul style="list-style-type: none"> Only authorized personnel should perform sling work and operate a crane and a forklift. When these operations are performed by unauthorized personnel, it is extremely hazardous and may result in serious bodily injury and/or severe equipment damage to the robot system.
--	--

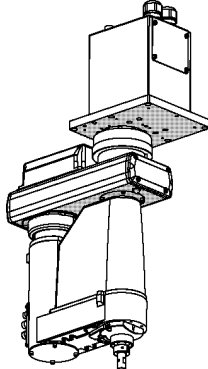
 CAUTION	<ul style="list-style-type: none"> Before relocating the Manipulator, fold the arm and secure it tightly with a wire tie to prevent hands or fingers from being caught in the Manipulator. When removing the anchor bolts, support the Manipulator to prevent falling. Removing the anchor bolts without support may result in a fall of the Manipulator, and then get hands, fingers, or feet caught. To transport the Manipulator, have two or more people to work on it and secure the Manipulator to the delivery equipment or hold the areas indicated in gray in the figure (bottom of Arm #1 and bottom of the base) by hand. When holding the bottom of the base by hand, be very careful not to get your hands or fingers caught. <div style="text-align: right; margin-top: 20px;">  <p>RS3-351* : approx. 17 kg : 38 lb. RS4-551* : approx. 19 kg : 42 lb.</p> </div> <ul style="list-style-type: none"> Stabilize the Manipulator with your hands when hoisting it. Unstable hoisting is extremely hazardous and may result in fall of the Manipulator.
---	--

When transporting the Manipulator for a long distance, secure it to the delivery equipment so that the Manipulator cannot fall.

If necessary, pack the Manipulator in the same way as it was delivered.

When the Manipulator is used for a robot system again after long-term storage, perform a test run to verify that it works properly, and then operate it thoroughly.

Transport and store the Manipulator in the range of -25 to $+55^{\circ}\text{C}$.

Humidity 10 to 90% (no condensation) is recommended.

Transport and store the Manipulator in the range of Temperature: -25 to $+55^{\circ}\text{C}$, Humidity: 10 to 90% (no condensation).

When condensation occurs on the Manipulator during transport or storage, turn ON the power only after the condensation dries.

Do not shock or shake the Manipulator during transport.

3.8.2 Relocation procedure

 WARNING	<ul style="list-style-type: none"> ■ Install or relocate the Manipulator with two or more people. The Manipulator weights are as follows. Be careful not to get hands, fingers, or feet caught and/or have equipment damaged by a fall of the Manipulator. RS3-351* : approx. 17 kg: 38 lb. RS4-551* : approx. 19 kg: 42 lb. ■ When removing the Manipulator from the ceiling, support the Manipulator, and then remove the anchor bolts. Removing the anchor bolts without supporting is extremely hazardous and may result in fall of the Manipulator.
---	--

- (1) Turn OFF the power on all devices and unplug the cables.
- (2) Hold the bottom of Arm #1 by hand to unscrew the anchor bolts. Then, remove the Manipulator.

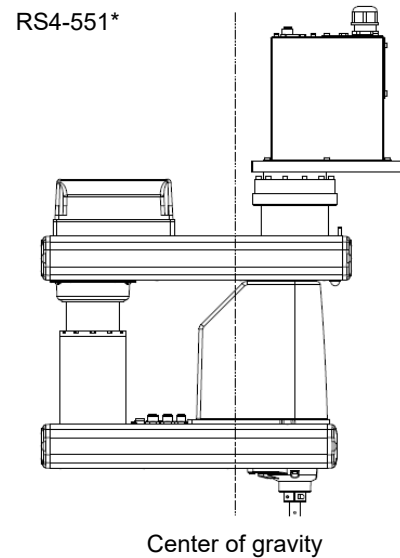
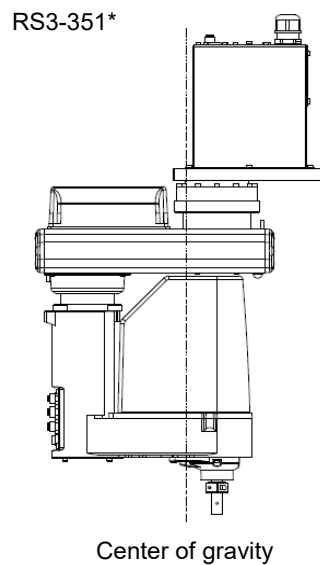

4. Setting of End Effectors

4.1 Attaching an End Effector

Users are responsible for making their own end effector(s). For details of attaching an end effector, refer to “*Hand Function Manual*”

 CAUTION	<ul style="list-style-type: none"> ■ If you use an end effector equipped with a gripper or chuck, connect wires and/or pneumatic tubes properly so that the gripper does not release the work piece when the power to the robot system is turned OFF. Improper connection of the wires and/or pneumatic tubes may damage the robot system and/or work piece as the work piece is released when the Emergency Stop switch is pressed. I/O outputs are configured at the factory so that they are automatically shut off (0) by power disconnection, the Emergency Stop switch, or the safety features of the robot system. <p>However, the I/O set in the hand function does not turn off (0) when the Reset command is executed or in emergency stop.</p>
--	--

Shaft

- Attach an end effector to the lower end of the shaft.
For the shaft dimensions, and the overall dimensions of the Manipulator, refer to 2. *Specifications*.
- Do not move the upper limit mechanical stop on the lower side of the shaft. Otherwise, when “Jump motion” is performed, the upper limit mechanical stop may hit the Manipulator, and the robot system may not function properly.
- Use a split muff coupling with an M4 bolt or larger to attach the end effector to the shaft.

Brake release switch

- Joint #3 cannot be moved up/down by hand because the electromagnetic brake is applied while power to the robot system is turned OFF.
This prevents the shaft from hitting peripheral equipment in the case that the shaft is lowered by the weight of the end effector when the power is disconnected during operation, or when the motor is turned OFF even though the power is turned ON.
When attaching an end effector, turn ON the Controller. Move Joint #3 up/down while pressing the brake release switch.
This button switch is a momentary-type; the brake is released only while the button switch is being pressed.

- Be careful of the shaft falling while the brake release switch is being pressed because the shaft may be lowered by the weight of the end effector.

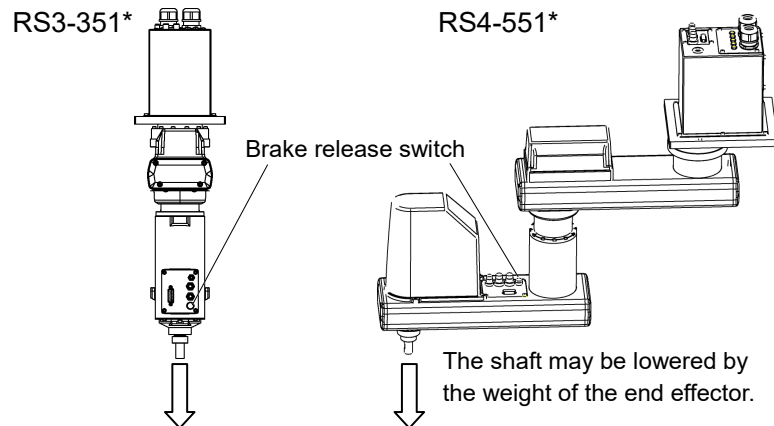

4.2 Attaching Cameras and Air valves



Arm #2 has threaded holes as shown in the figure below. Use these holes for attaching cameras, air valves, and other equipment. [Unit : mm]

RS3-351*

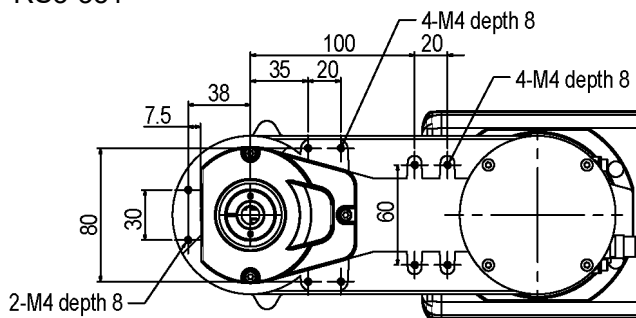

RS4-551*

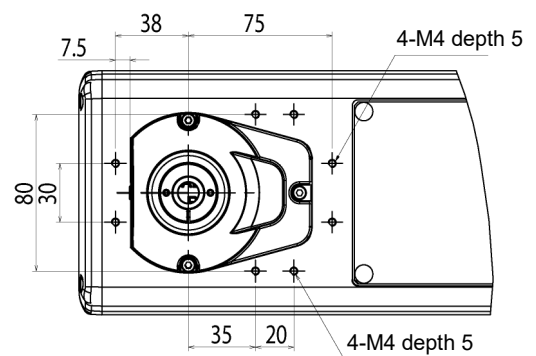

- When cameras and air valves are attached, it can limit the motion range by wires and pneumatic tubes. Take extra care when designing and attaching.
- The Joint #4 (rotating) motion range is ± 720 degrees. Be careful not to let the wires/tubes caught in the end effector.

4.3 Weight and Inertia Settings

To ensure optimum Manipulator performance, it is important to make sure that the load (weight of the end effector and work piece) and moment of inertia of the load are within the maximum rating for the Manipulator, and that Joint #4 does not become eccentric.

If the load or moment of inertia exceeds the rating or if the load becomes eccentric, follow the steps below, “4.3.1 Weight Setting” and “4.3.2 Inertia Setting” to set parameters.

Setting parameters makes the PTP motion of the Manipulator optimal, reduces vibration to shorten the operating time, and improves the capacity for larger loads. In addition, it reduces persistent vibration produced when the moment of inertia of the end effector and work piece is larger than the default setting.

You can also set by following “Weight, Inertia, and Eccentricity/offset Measurement Utility”. The following manual describes the details.

Epson RC+ User’s Guide

6.18.12 Weight, Inertia, and Eccentricity/offset Measurement Utility

4.3.1 Weight Setting

 CAUTION	<ul style="list-style-type: none"> ■ The total weight of the end effector and the work piece must not exceed RS3-351*: 3 kg, RS4-551*: 4 kg. The RS series Manipulators are not designed to work with loads exceeding RS3-351*: 3 kg, RS4-551*: 4 kg. Always set the Weight parameters according to the load. Setting a value that is smaller than the actual load may cause errors, excessive shock, insufficient function of the Manipulator, and/or shorten the life cycle of parts/mechanisms.
---	---

The acceptable weight capacity (end effector and work piece) in RS series is 1 kg at the default rating and RS3-351*: 3 kg, RS4-551*: 4 kg at the maximum. Depends to the load (weight of the end effector and work piece), change the setting of Weight parameter.

After the setting is changed, the maximum acceleration/deceleration speed of the robot system at PTP motion corresponding to the “Weight Parameter” is set automatically.

Load on the Shaft

The load (weight of the end effector and work piece) on the shaft can be set by Weight parameter.

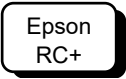

Enter a value into the [Weight] text box on the [WEIGHT] panel ([Tools]-[Robot Manager]). (You may also execute the Weight command from the [Command Window].)

Load on the Arm

When you attach a camera or other devices to the arm, calculate the weight as the equivalent of the shaft. Then, add this to the weight of the load attached to the shaft, and the total weight to the Weight parameter.

Equivalent Weight Formula

$$W_M = M \times (L_M + L_1)^2 / (L_1 + L_2)^2$$

W_M : equivalent weight

M : weight of load attached to the arm

L_1 : length of Arm #1

L_2 : length of Arm #2

L_M : distance from rotation center of Joint #2 to center of gravity of load attached to the arm

<Example> Calculates [Weight] parameter when a “0.5 kg” camera is attached to the end of the RS3 arm (250 mm away from the rotation center of Joint #2) with a load weight of “1 kg”.

$$W = 1.0$$

$$M = 0.5$$

$$L_1 = 175$$

$$L_2 = 175$$

$$L_M = 250$$

$$W_M = 0.5 \times (250 + 175)^2 / (175 + 175)^2 = 0.74$$

(round up)

$$W + W_M = 1 + 0.74 = 1.74$$

Enter “1.74” for the Weight Parameter.

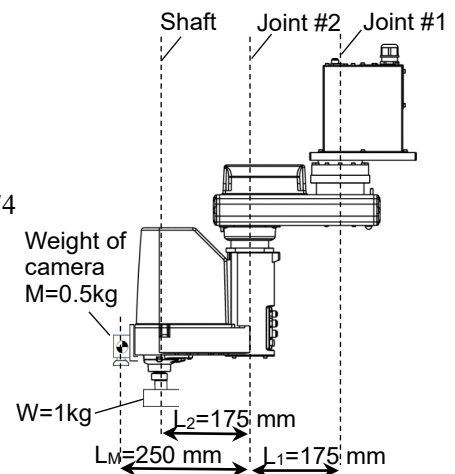

Automatic speed setting by Weight

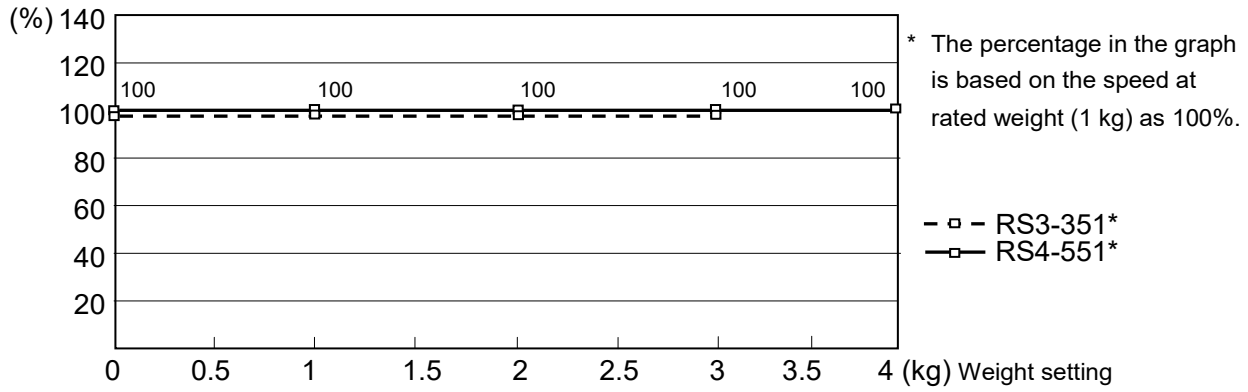

Automatic acceleration/deceleration setting by Weight

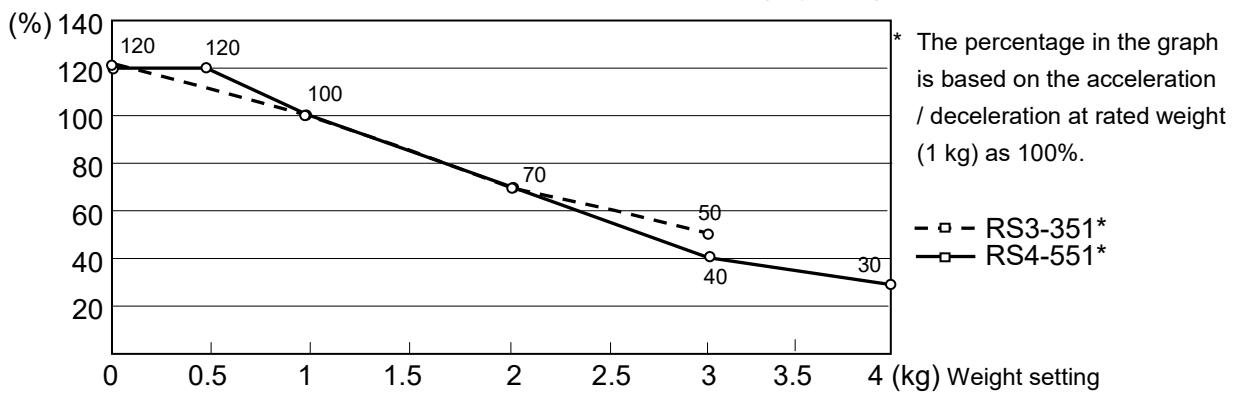

4.3.2 Inertia Setting

Moment of Inertia and the Inertia Setting

The moment of inertia is defined as “the ratio of the torque applied to a rigid body and its resistance to motion”. This value is typically referred to as “the moment of inertia”, “inertia”, or “GD²”. When the Manipulator operates with additional objects (such as an end effector) attached to the shaft, the moment of inertia of load must be considered.

 CAUTION	<ul style="list-style-type: none"> ■ The moment of inertia of the load (weight of the end effector and work piece) must be 0.05 kg·m² or less. The RS series Manipulators are not designed to work with a moment of inertia exceeding 0.05 kg·m². Always set the moment of inertia parameter to the correct moment of inertia. Setting a value that is smaller than the actual moment of inertia may cause errors, excessive shock, insufficient function of the Manipulator, and/or shorten the life cycle of parts/mechanisms.
---	---

The acceptable moment of inertia of load for a RS series Manipulator is 0.005 kg·m² at the default rating and 0.05 kg·m² at the maximum. Depends to the moment of inertia of the load, change the setting for the moment of inertia of the load of the Inertia command. After the setting is changed, the maximum acceleration/deceleration speed of Joint #4 at PTP motion corresponding to the “moment of inertia” value is set automatically.

Moment of inertia of load on the shaft

The moment of inertia of load (weight of the end effector and work piece) on the shaft can be set by the “moment of inertia” parameter of the Inertia command.

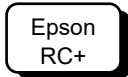

Enter a value into the [Load inertia:] text box on the [Inertia] panel ([Tools]-[Robot Manager]). (You may also execute the Inertia command from the [Command Window].)

Automatic acceleration/deceleration setting of Joint #4 by Inertia (moment of inertia)

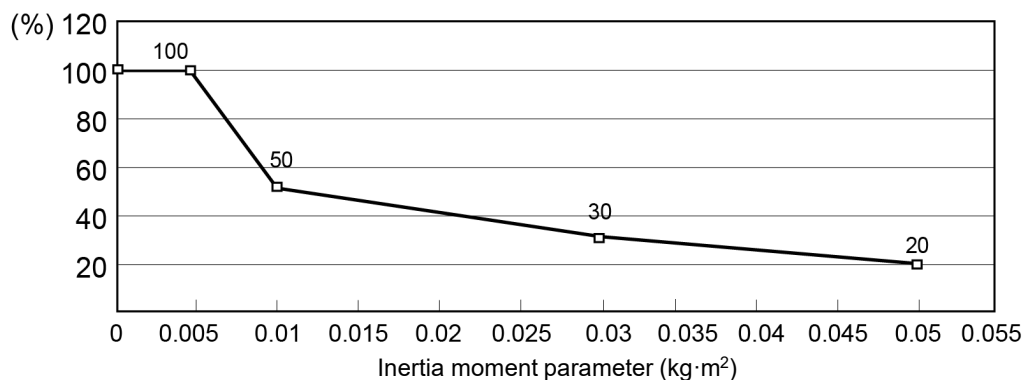

Eccentric Quantity and the Inertia Setting



CAUTION

- The eccentric quantity of load (weight of the end effector and work piece) must be 100 mm or less. The RS series Manipulators are not designed to work with eccentric quantity exceeding 100 mm. Always set the eccentric quantity parameter according to the eccentric quantity. Setting a value that is smaller than the actual eccentric quantity may cause errors, excessive shock, insufficient function of the Manipulator, and/or shorten the life cycle of parts/mechanisms.

The acceptable eccentric quantity of load in RS series is 0 mm at the default rating and 100 mm at the maximum. Depends to the eccentric quantity of load, change the setting of eccentric quantity parameter of Inertia command. After the setting is changed, the maximum acceleration/deceleration speed of the Manipulator at PTP motion corresponding to the “eccentric quantity” is set automatically.

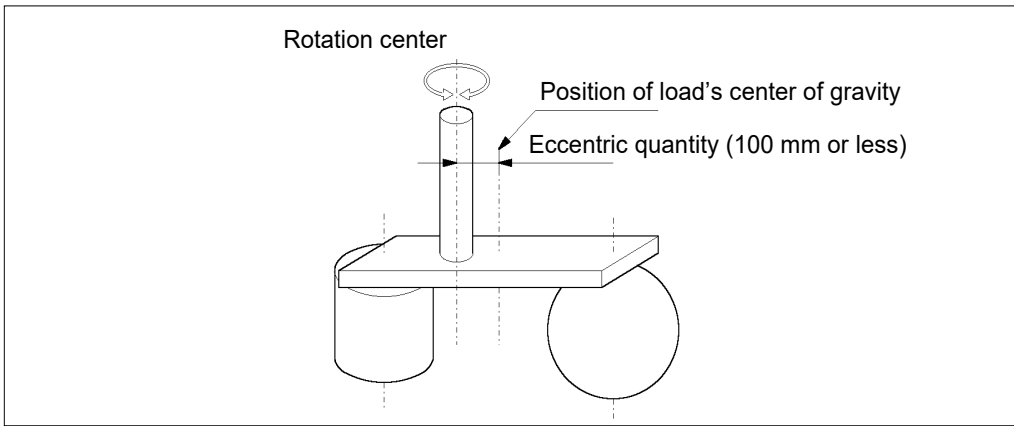

Eccentric quantity of load on the shaft

The eccentric quantity of load (weight of the end effector and work piece) on the shaft can be set by “eccentric quantity” parameter of Inertia command.

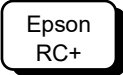

Enter a value into the [Eccentricity:] text box on the [Inertia] panel ([Tools] - [Robot Manager]). (You may also execute the Inertia command from the [Command Window].)

Automatic acceleration/deceleration setting by Inertia (eccentric quantity)

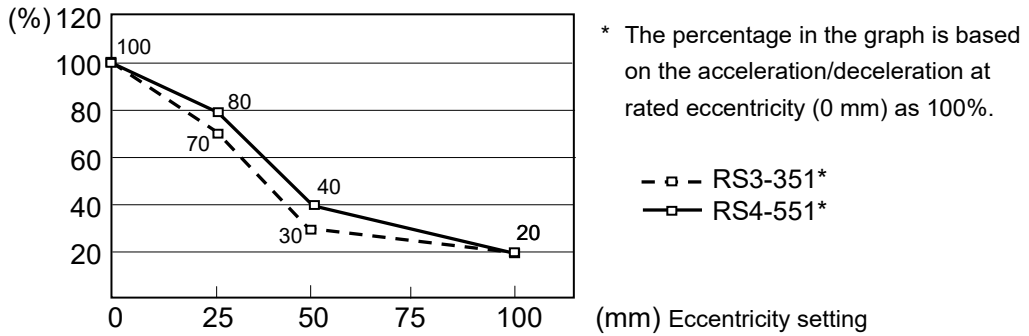

Calculating the Moment of Inertia

Refer to the following examples of formulas to calculate the moment of inertia of load (end effector with work piece).

The moment of inertia of the entire load is calculated by the sum of each part (a), (b), and (c).

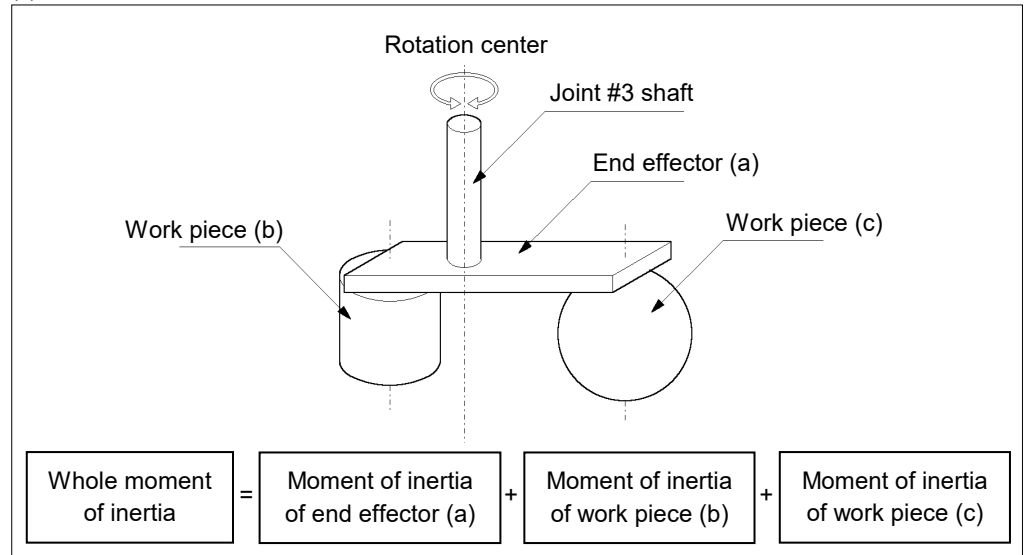

The methods for calculating the moment of inertia for (a), (b), and (c) are shown below. Calculate the total moment of inertia using the basic formulas.

(a) Moment of inertia of a rectangular parallelepiped

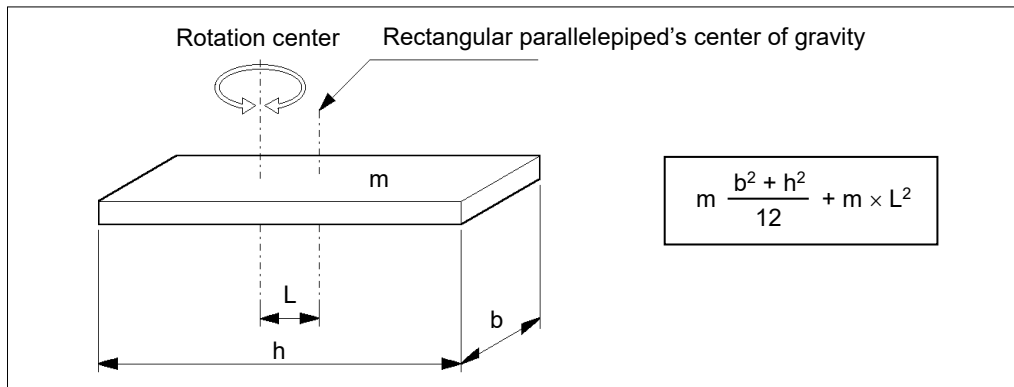

(b) Moment of inertia of a cylinder

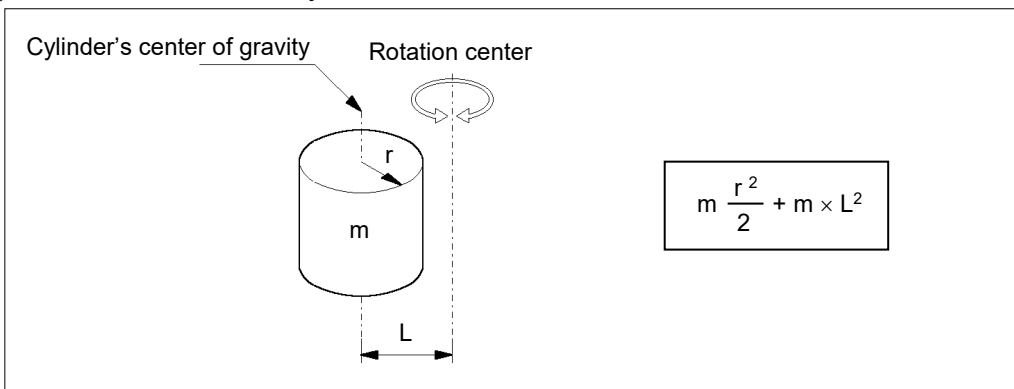

(c) Moment of inertia of a sphere

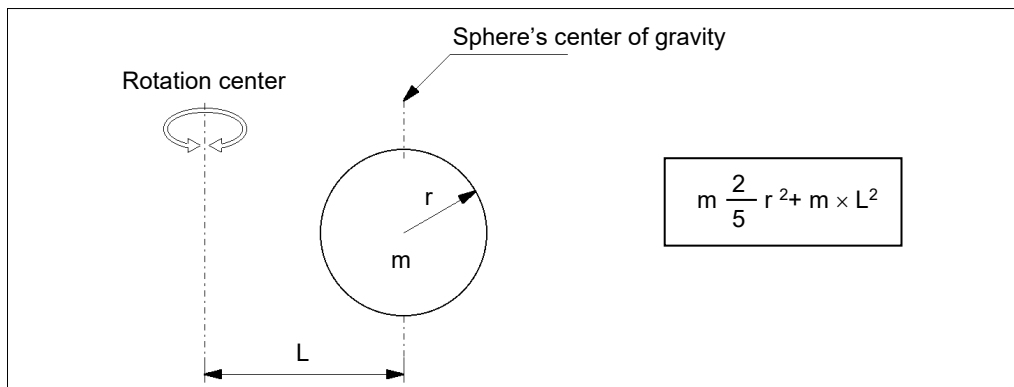

4.4 Precautions for Auto Acceleration/Deceleration of Joint #3

When you move the Manipulator in horizontal PTP motion with Joint #3 (Z) at a high position, the motion time will be faster.

When Joint #3 gets below a certain point, then auto acceleration/deceleration is used to reduce acceleration/deceleration. (Refer to the figure below.) The higher the position of the shaft is, the faster the motion acceleration/deceleration is. However, it takes more time to move Joint #3 up and down. Adjust the position of Joint #3 for the Manipulator motion after considering the relation between the current position and the destination position.

The upper limit of Joint #3 during horizontal motion using Jump command can be set by the LimZ command.

Automatic acceleration/deceleration vs. Joint #3 position

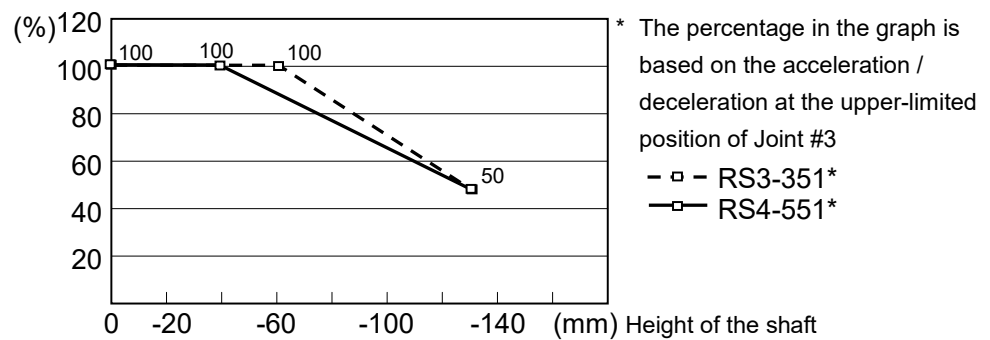

NOTE

When moving the Manipulator horizontally while the shaft is being lowered, it may cause over-shoot at the time of final positioning.

5. Motion Range



- When setting up the motion range for safety, both the pulse range and mechanical stops must always be set at the same time.

The motion range is preset at the factory as explained in 5.4 *Standard Motion Range*. That is the maximum motion range of the Manipulator.

There are three methods for setting the motion range described as follows:

1. Setting by pulse range (for all joints)
2. Setting by mechanical stops (for Joints #3)
3. Setting the Cartesian (rectangular) range in the X, Y coordinate system of the Manipulator (for Joints #1 and #2)

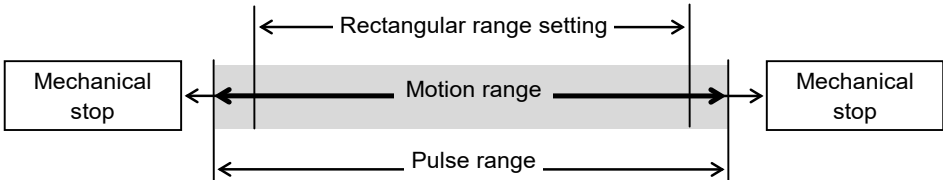

When the motion range is changed due to layout efficiency or safety, follow the descriptions in 5.1 to 5.3 to set the range.

5.1 Motion Range Setting by Pulse Range

Pulses are the basic unit of Manipulator motion. The motion range of the Manipulator is controlled by the pulse range between the pulse lower limit and upper limit of each joint. Pulse values are read from the encoder output of the servo motor.

For the maximum pulse range, refer to the following sections. The pulse range must be set inside of the mechanical stop range.

- 5.1.1 *Max. Pulse Range of Joint #1*
- 5.1.2 *Max. Pulse Range of Joint #2*
- 5.1.3 *Max. Pulse Range of Joint #3*
- 5.1.4 *Max. Pulse Range of Joint #4.*



Once the Manipulator receives an operating command, it checks whether the target position specified by the command is within the pulse range before operating. If the target position is out of the set pulse range, an error occurs and the Manipulator does not move.

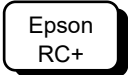

The pulse range can be set on the [Range] panel shown by selecting [Tools]-[Robot Manager]. (You may also execute the Range command from the [Command Window].)

5.1.1 Max. Pulse Range of Joint #1

The 0 (zero) pulse position of Joint #1 is the position where Arm #1 faces toward the positive (+) direction on the X-coordinate axis.

When the 0 pulse is a starting point, the counterclockwise pulse value is defined as the positive (+) and the clockwise pulse value is defined as the negative (-).

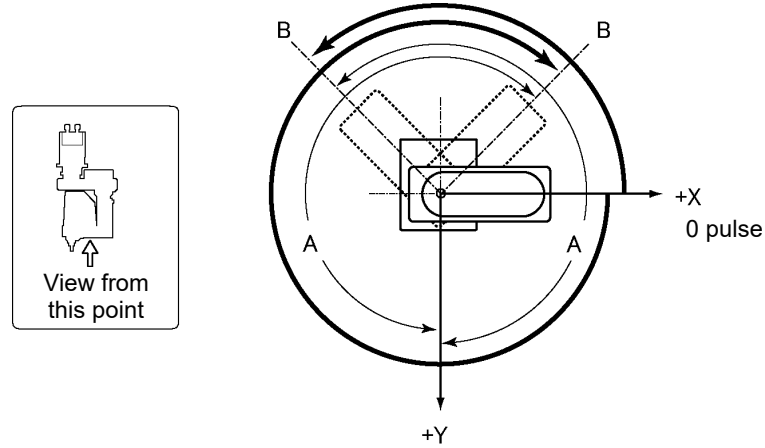

A : Max. motion range : $\pm 225^\circ$

B : Max. pulse range : - 2560000 to +5973334 pulse (RS3-351*)
 - 4096000 to + 9557334 pulse (RS4-551*)

5.1.2 Max. Pulse Range of Joint #2

The 0 (zero) pulse position of Joint #2 is where Arm #2 overlaps straight with Arm #1 as shown in the figure below. With the 0 pulse as a starting point, the counterclockwise pulse value is defined as the positive (+) and the clockwise pulse value is defined as the negative (-).

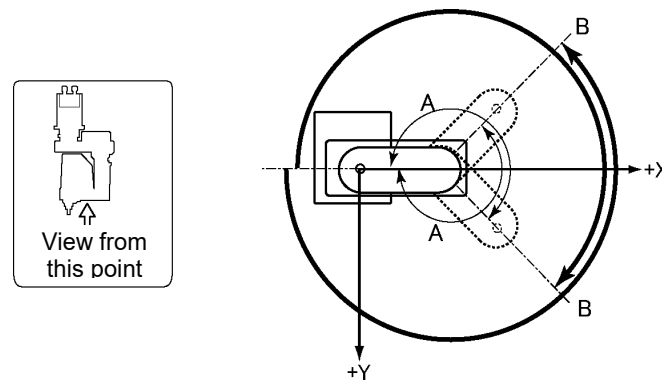

A : Max. motion range : $\pm 225^\circ$

B : Max. pulse range : - 4177920 to + 4177920 pulse

5.1.3 Max. Pulse Range of Joint #3

The 0 (zero) pulse position of Joint #3 is the position where the shaft is at its upper limit. The pulse value is always negative because Joint #3 always moves lower than the 0 pulse position.

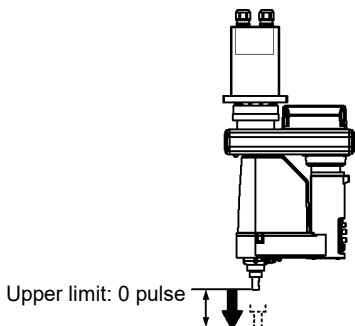

Type	Joint #3 stroke	Lower limit pulse value
RS3-351S/RS4-551S	130 mm	- 1479112 pulse
RS3-351C/RS4-551C	100 mm	- 1137778 pulse

5.1.4 Max. Pulse Range of Joint #4

The 0 (zero) pulse position of Joint #4 is the position where the flat near the end of the shaft faces toward the end of Arm #2. With the 0 pulse as a starting point, the counterclockwise pulse value is defined as the positive (+) and the clockwise pulse value is defined as the negative (-).

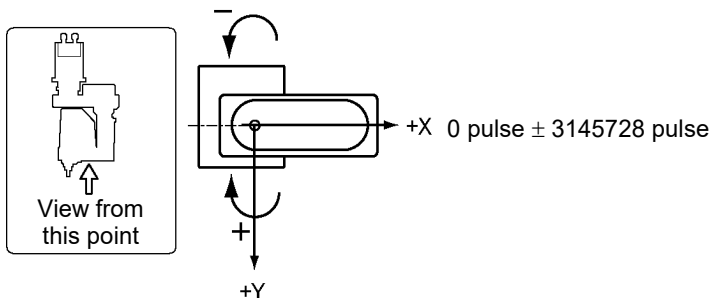

5.2 Motion Range Setting by Joint #3 Mechanical Stops

- (1) Turn ON the Controller and turn OFF the motors using the Motor OFF command.
- (2) Remove the Arm #2 cover (4-M4×10).
- (3) Push up the shaft while pressing the brake release switch.



When you press the brake release switch, the shaft may lower due to the weight of the end effector. Be sure to hold the shaft by hand while pressing the button.

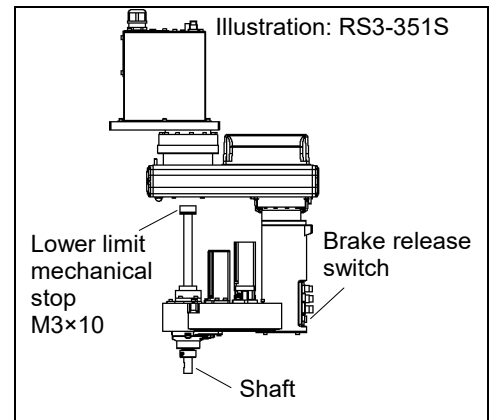

- (4) Turn OFF the Controller.
- (5) Loosen the lower limit mechanical stop screw (M3×10).



A mechanical stop is mounted on both the top and bottom of Joint #3. However, only the position of the lower limit mechanical stop on the top can be changed. Do not remove the upper limit mechanical stop on the bottom because the calibration point of Joint #3 is specified using the stop.

- (6) The upper end of the shaft defines the maximum stroke. Move the lower limit mechanical stop down by the length you want to limit the stroke. For example, when the lower limit mechanical stop is set at “130 mm” stroke, the lower limit Z coordinate value is “-130”. To change the value to “-100”, move the lower limit mechanical stop down “30 mm”. Use calipers to measure the distance when adjusting the mechanical stop.

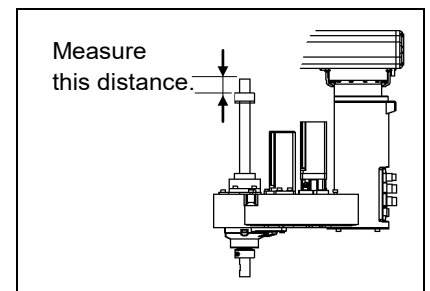

- (7) Firmly tighten two lower limit mechanical stop screws (M3×10).
Recommended tightening torque: 2.45 N·m (25 kgf·cm)
- (8) Turn ON the Controller.
- (9) Move Joint #3 to its lower limit while pressing the brake release switch, and then check the lower limit position. Do not lower the mechanical stop too far. Otherwise, the joint may not reach a target position.

- (10) Calculate the lower limit pulse value of the pulse range using the formula shown below and set the value.

The result of the calculation is always negative because the lower limit Z coordinate value is negative.

<p>Lower limit of pulse (pulse) = lower limit Z coordinate value (mm) / Resolution (mm/pulse)</p>
--

** For the Joint #3 resolution,

refer to the section *Appendix A: Specifications*.

Epson
RC+

Execute the following command from the [Command Window]. Enter the calculated value in X.

>J RANGE 3, X, 0 'Sets the pulse range of Joint #3

- (11) Use the Pulse command (Go Pulse command), and move Joint #3 to the lower limit position of the pulse range at low speed.

If the mechanical stop range is less than the pulse range, Joint #3 will hit the mechanical stop and an error will occur. When the error occurs, either change the pulse range to a lower setting or extend the position of the mechanical stop within the limit.

NOTE



If it is difficult to check whether Joint #3 hits a mechanical stop, turn OFF the Controller and lift the arm top cover to check the condition causing the problem from the side.

Epson
RC+

Execute the following commands from the [Command Window]. Enter the value calculated in Step (10) in X.

>MOTOR ON 'Turns ON the motor

>SPEED 5 'Sets low speed

>PULSE 0, 0, X, 0 'Moves to the lower limit-pulse position of Joint #3.

(In this example, all pulses except those for Joint #3 are "0". Substitute these "0s" with the other pulse values specifying a position where there is no interference even when lowering Joint #3.)

5.3 Setting the Cartesian (Rectangular) Range in the XY Coordinate System of the Manipulator (for Joints #1 and #2)

Use this method to set the upper and lower limits of the X and Y coordinates.

This setting is only enforced by software. Therefore, it does not change the physical range. The maximum physical range is based on the position of the mechanical stops.

Epson
RC+

Set the XYLim setting on the [XYZ Limits] panel shown by selecting [Tools]-[Robot Manager].

(You may also execute the XYLim command from the [Command Window].)

5.4 Standard Motion Range

The following “motion range” diagrams show the standard (maximum) specification. When each Joint motor is under servo control, the center of Joint #3’s (shaft’s) lowest point moves in the areas shown in the figure.

“Area limited by mechanical stop” is the area where the center of Joint #3’s lowest point can be moved when each joint motor is not under servo control.

“Mechanical stop” sets the limited motion range so that the center of Joint #3 cannot move beyond the area mechanically.

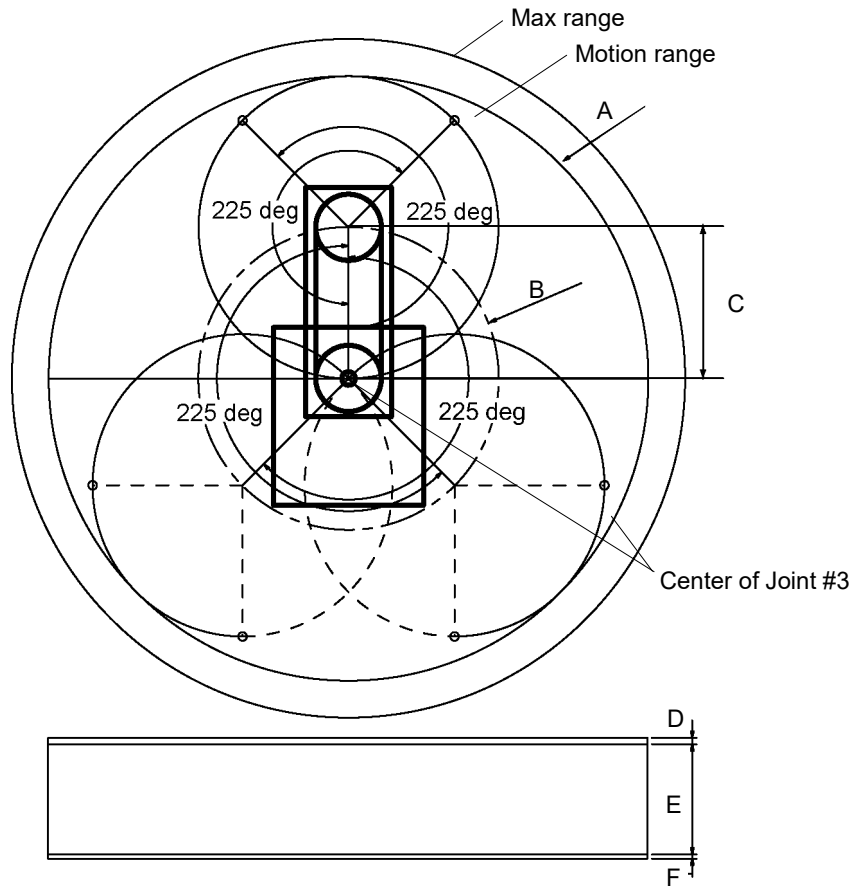

	RS3-351S	RS3-351C	RS4-551S	RS4-551C	
A	R350		R550		
B	R175		R275		
C	175 mm		275 mm		Arm#1, Arm#2 length
D	4	6.5	6	8.5	Joint #3 range to hit upper mechanical stop
E	130	100	130	100	Joint #3 stroke
F	1.8	3.8	4.8	7.8	Joint #3 range to hit lower mechanical stop

Regular Inspection

This volume contains maintenance procedures with safety precautions for RS series Manipulators.

1. General Maintenance for RS3 RS4

1.1 Maintenance Inspection

1.1.1 Schedule for Maintenance Inspection

Inspection points are divided into five stages: daily, monthly, quarterly, biannual, and annual. The inspection points are added every stage.

If the Manipulator is operated for 250 hours or longer per month, the inspection points must be added every 250 hours, 750 hours, 1500 hours, and 3000 hours operation.

h = hour

	Inspection Point					
	Daily inspection	Monthly inspection	Quarterly inspection	Biannual inspection	Annual inspection	Overhaul (replacement)
1 month (250 h)	Inspect every day	√				
2 months (500 h)		√				
3 months (750 h)		√	√			
4 months (1000 h)		√				
5 months (1250 h)		√				
6 months (1500 h)		√	√	√		
7 months (1750 h)		√				
8 months (2000 h)		√				
9 months (2250 h)		√	√			
10 months (2500 h)		√				
11 months (2750 h)		√				
12 months (3000 h)		√	√	√	√	
13 months (3250 h)		√				
⋮	⋮	⋮	⋮	⋮	⋮	⋮
20000 h						√

1.1.2 Inspection Point

Inspection Item

Inspection Point	Inspection Place	Daily	Monthly	Quarterly	Biannual	Annual
Check looseness or backlash of bolts/screws.	End effector mounting bolts	√	√	√	√	√
	Manipulator mounting bolts	√	√	√	√	√
Check looseness of connectors.	External connectors on Manipulator (on the connector plates etc.)	√	√	√	√	√
Visually check for external defects. Clean up if necessary.	External appearance of Manipulator	√	√	√	√	√
	External cables		√	√	√	√
Check for bends or improper location. Repair or place it properly if necessary.	Safeguard etc.	√	√	√	√	√
Check the brake operation	Break for arm #3	√	√	√	√	√
Check whether unusual sound or vibration occurs.	Whole	√	√	√	√	√

Inspection Method

Inspection Point	Inspection Method
Check looseness or backlash of bolts/screws.	Use a hexagonal wrench to check that the end effector mounting bolts and the Manipulator mounting bolts are not loose. When the bolts are loose, refer to “2.4 Tightening Hexagon Socket Head Bolts” and tighten them to the proper torque.
Check looseness of connectors.	Check that connectors are not loose. When the connectors are loose, reattach it not to come off.
Visually check for external defects. Clean up if necessary.	Check the appearance of the Manipulator and clean up if necessary. Check the appearance of the cable, and if it is scratched, check that there is no cable disconnection.
Check for bends or improper location. Repair or place it properly if necessary.	Check that the safeguard, etc. are located properly. If the location is improper, place it properly.
Check the brake operation	Check that the shaft does not fall when in MOTOR OFF. If the shaft falls when in MOTOR OFF and the brake is not released, contact the supplier.
Check whether unusual sound or vibration occurs.	Check that there is no unusual sound or vibration when operating. If there is something wrong, contact the supplier.

1.2 Overhaul (Parts Replacement)

Overhaul (replacement) shall be performed by personnel who has taken a proper training.

For details, refer to “*Safety Manual Training*”.

For details of overhaul, refer to *Maintenance Manual*.

1.3 Greasing

The ball screw spline and reduction gear units need greasing regularly. Only use the grease specified in the following table.

 CAUTION	<ul style="list-style-type: none"> ■ Wear protective gear including a mask, protective goggles, and oilresistant gloves during grease up. If grease gets into your eyes, mouth, or on your skin, follow the instructions below. <ul style="list-style-type: none"> If grease gets into your eyes <ul style="list-style-type: none"> : Flush them thoroughly with clean water, and then see a doctor immediately. If grease gets into your mouth <ul style="list-style-type: none"> : If swallowed, do not induce vomiting. See a doctor immediately. : If grease just gets into your mouth, wash out your mouth with water thoroughly. If grease gets on your skin <ul style="list-style-type: none"> : Wash the area thoroughly with soap and water.
--	---

	Greasing part	Greasing Interval	Grease	How to grease
Joint #1, Joint #2	Reduction gear units	Overhaul timing	-	Greasing shall be performed by personnel who has taken a proper training. For details, refer to the G series Manipulator Maintenance Manual.
Joint #3	Ball screw spline unit	At 100 km of operation (50 km for first greasing)	AFB	<i>Greasing the Ball Screw Spline Unit (See Below)</i>

Joint #3 Ball screw spline unit

The recommended greasing interval is at 100 km of operation. However, greasing timing also can be checked from the grease condition. Perform greasing if the grease is discolored or becomes dry.

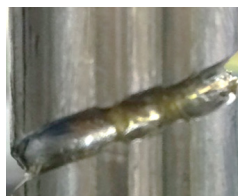

Normal grease



Discolored grease

Perform greasing at 50 km of operation for the first time of greasing.



NOTE For the EPSON RC+ 7.0 Ver. 7.2.x or later (firmware Ver.7.2.x.x or later), the recommended replacement time for the grease on the ball screw spline unit can be checked in the [Maintenance] dialog box of the Epson RC+. For details, refer to the following manual.

RC700 series Maintenance Manual 6. Alarm

Greasing the Ball Screw Spline Unit

	Name	Quantity	NOTE
Grease	For Ball Screw Spline Unit (AFB grease)	Proper quantity	
Tools	Wiping cloth	1	For wiping grease (Spline shaft)
	Cross-point screwdriver	1	For clamp band removal Only for Cleanroom-model

NOTE
 Cover the surrounding area such as the end effector and peripheral equipment in case the grease drips.

- (1) Turn ON the Controller.
- (2) Move the shaft to the lower limit by using one of the following methods:
 - Move the shaft to the lower limit manually while pressing the brake release switch.

NOTE
 Be careful of the shaft falling and rotating while the brake release switch is being pressed because the shaft may be lowered by the weight of the end effector.

- Move the shaft to the lower limit manually while by selecting Epson RC+ menu - [Tools] - [Robot Manager] - [Jog & Teach].

NOTE
 Be sure to keep enough space and prevent the end effector hitting any peripheral equipment.

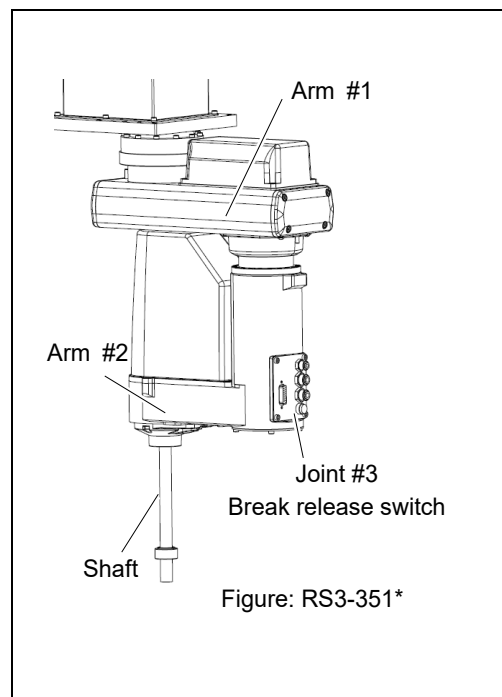

- (3) Turn OFF the Controller.
- (4) Wipe off the old grease from the shaft, and then apply new grease to it.

Grease application range is from the end of the spline nut to mechanical stop.

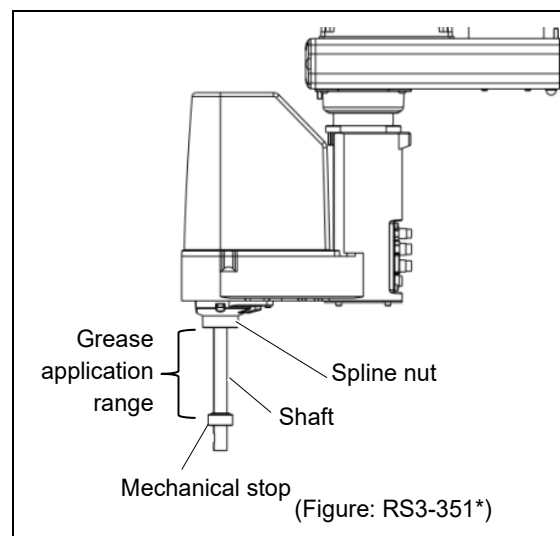

- (5) Apply new grease evenly to the spiral groove of the ball screw spline unit and the vertical groove so that the groove is filled.



- (6) Turn ON the Controller.
- (7) Start the robot manager and move the shaft to the origin position. Be careful not to hit peripheral equipment.
- (8) After moving to the origin position, reciprocate the shaft. The reciprocating operation is a low power mode operation program that performs from the upper limit to the lower limit. Run for about 5 minutes to spread the grease over the shaft.

- (9) Turn OFF the controller.
- (10) Wipe off excess grease on the end of the spline nut and mechanical stop.

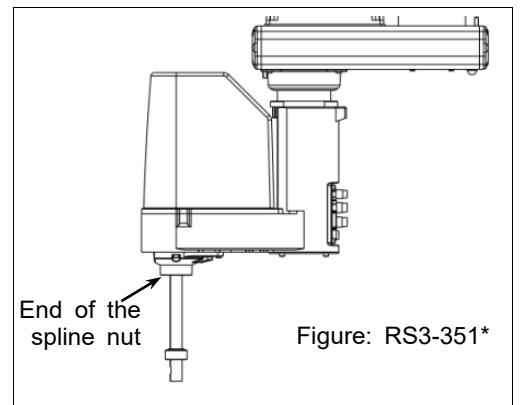

1.4 Tightening Hexagon Socket Head Cap Bolts

Hexagon socket head cap bolts are used in places where mechanical strength is required. (A hexagon socket head cap bolt will be called a “bolt” in this manual.) These bolts are fastened with the tightening torques shown in the following table.

When it is necessary to refasten these bolts in some procedures in this manual (except special cases as noted), use a torque wrench so that the bolts are fastened with the appropriate tightening torques as shown below.

Bolt	Tightening Torque
M3	2.0 ± 0.1 N·m (21 ± 1 kgf·cm)
M4	4.0 ± 0.2 N·m (41 ± 2 kgf·cm)
M5	8.0 ± 0.4 N·m (82 ± 4 kgf·cm)
M6	13.0 ± 0.6 N·m (133 ± 6 kgf·cm)
M8	32.0 ± 1.6 N·m (326 ± 16 kgf·cm)
M10	58.0 ± 2.9 N·m (590 ± 30 kgf·cm)
M12	100.0 ± 5.0 N·m (1,020 ± 51 kgf·cm)

Refer below for the set screw.

Set Screw	Tightening Torque
M4	2.4 ± 0.1 N·m (26 ± 1 kgf·cm)
M5	3.9 ± 0.2 N·m (40 ± 2 kgf·cm)

We recommend that the bolts aligned on a circumference should be fastened in a crisscross pattern as shown in the figure below.

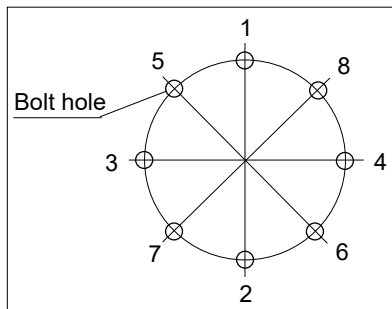

Do not fasten all bolts securely at one time. Divide the number of times that the bolts are fastened into two or three and fasten the bolts securely with a hexagonal wrench. Then, use a torque wrench so that the bolts are fastened with tightening torques shown in the table above.

Appendix

This volume describes the specifications table for each model and detailed data of stopping time and stopping distance.

Appendix A: Specification

RS3 RS4 Specification

Item		RS3-351*	RS4-551*
Arm length	Arm #1, #2	350 mm	550 mm
	Arm #1	175 mm	275 mm
	Arm #2	175 mm	275 mm
Max. operating speed *1	Joints #1, #2	6237 mm/s	7400 mm/s
	Joints # 3	1100 mm/s	
	Joint #4	2600 deg/s	
Repeatability	Joints #1, #2	± 0.01 mm	± 0.015 mm
	Joints # 3	± 0.01 mm	
	Joint #4	± 0.01 deg	
Payload (Load)	Rated	1 kg	
	Max.	3 kg	4 kg
Joint #4 allowable moment of inertia *2	Rated	0.005 kg·m ²	
	Max.	0.05 kg·m ²	
Max. motion range	Joint #1	± 225 deg	
	Joint #2	± 225 deg	
	Joint #3	RS*-*1S: 130 mm RS*-*1C: 100 mm	
	Joint #4	± 720 deg	
Max. pulse range (pulse)	Joint #1	- 2560000 to + 5973334 pulse	-4096000 ~ + 9557334 pulse
	Joint #2	± 4177920 pulse	
	Joint #3	RS*-*1S: - 1479112 pulse to 0 pulse RS*-*1C: - 1137778 pulse to 0 pulse	
	Joint #4	± 3145728 pulse	
Resolution	Joint #1	0.0000527 deg/pulse	0.0000330deg/pulse
	Joint #2	0.0000538 deg/pulse	
	Joint #3	0.0000879 mm/pulse	
	Joint #4	0.000229 deg/pulse	
Hand diameter	Mounting	ø 16 mm	
	Hollow	ø 11 mm	
Mounting hole		6-M6	
Weight (cables not included) (Common to Standard & Cleanroom-model)		17 kg: 38 lb	19 kg: 42 lb
Driving method		AC servo motor	
Motor rated capacity	Joint #1	400 W	
	Joint #2	200 W	400 W
	Joint #3	150 W	
	Joint #4	100 W	
Option	Environment	Cleanroom & ESD *3	
Joint #3 down force		150 N	
Installed wire for customer use		15 wires: D-sub, 15 pin connectors	
Installed pneumatic tube for customer use		2 pneumatic tubes (ø 6 mm): 0.59 MPa (6 kgf/cm ² : 86 psi)	
		1 pneumatic tube (ø 4 mm): 0.59 MPa (6 kgf/cm ² : 86 psi)	
Environmental requirements *4	Ambient temperature	5 to 40°C	
	Ambient relative humidity	10 to 80% RH (no condensation)	
Noise level *5		LAeq = 70 dB (A) or under	
Applicable Controller		RC700-A	

Item		RS3-351*	RS4-551*
Assignable Value () Default values	SPEED	1 to (5) to 100	
	ACCEL *6	1 to (10) to 120	
	SPEEDS	0.1 to (50) to 2000	
	ACCELS	0.1 to (200) to 25000	
	FINE	0 to (10000) to 65535	
	WEIGHT	0 to (1) to 3	0 to (1) to 4

*1: In the case of PTP command. Maximum operating speed for CP command is 2000 mm/s on horizontal plane.

*2: In the case where the center of gravity is at the center of Joint #4.

If the center of gravity is not at the center of Joint #4, set the parameter using Inertia command.

*3: The exhaust system in the Cleanroom-model Manipulator draws air from the base interior and arm cover interior together.

A crack or other opening in the base unit can cause loss of negative air pressure in the outer part of the arm, which can cause increased dust emission.

Do not remove the maintenance cover on the front of the base.

Seal the exhaust port and the exhaust tube with vinyl tape so that the joint is airtight.

If the exhaust flow is not sufficient, dust particle emission may exceed the specified maximum level.

Cleanliness level: Class ISO 3 (ISO14644-1)

Exhaust System: Exhaust port diameter : Inner diameter: ϕ 12 mm / Outer diameter: ϕ 16 mm

Exhaust tube : Polyurethane tube

Outer diameter: ϕ 12 mm (Inner diameter: ϕ 8 mm)

or Inner diameter ϕ 16mm or larger

Recommended exhaust flow rate: approx. 1000 cm³/s (Normal)

ESD specification uses resin materials with antistatic treatment. This model controls adhesion of dust due to electrification.

*4: When the product is used in a low temperature environment around the minimum temperature of the product specification, or when the product is suspended for a long time on holidays or at night, a collision detection error may occur due to the large resistance of the drive unit immediately after the start of operation. In such a case, it is recommended to warm up for about 10 minutes.

*5: Conditions of Manipulator during measurement as follows:

Operating conditions : Under rated load, 4-joints simultaneous motion, maximum speed, maximum acceleration/deceleration, and duty 50%.

Measurement point : Rear of the Manipulator, 1000 mm apart from the motion range, 50 mm above the base-installed surface.

*6: In general use, Accel setting 100 is the optimum setting that maintains the balance of acceleration and vibration when positioning. Although values larger than 100 can be set to Accel, it is recommended to minimize the use of large values to necessary motions since operating the manipulator continuously with the large Accel setting may shorten the product life remarkably.

Appendix B: Stopping time and Stopping distance in Emergency

The stopping time and stopping distance in emergency stop are shown in a graph for each model.

The stopping time is “Stopping time” in the figure below. Be sure to confirm that safety is ensured according to the installation environment and operation of the robot.

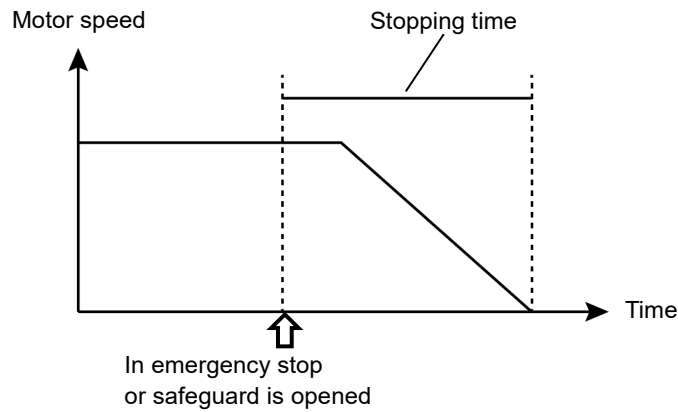

Condition:

The stopping time and stopping distance vary depending on the parameters (setting value) set for the robot. In this chapter, the time and distance are shown with the following parameters.

These conditions are based on the ISO 10218-1:2011 Annex B.

Accel : 100 ,100

Speed: 100 %, 66 %, 33 %Settings

Weight: 100 %, 66 %, 33 % of the maximum payload, rated payload

Arm elongation rate: 100 %, 66 %, 33 % *1

Other : Default

Motion: Singular axis motion of a Go command

Input timing of the Stop signal: input with maximum speed. In this motion, it is the center of the motion range.

*1 Arm elongation rate

When J1 is operating, the arm elongation rate θ is as shown in the figure below.

Among the following arm elongation rate, the graph shows the results with the longest stopping time and stopping distance.

When J2 is operating, J3 is 0 mm.

Axis	$\theta = 100\%$	$\theta = 66\%$	$\theta = 33\%$
J1	J2: 0 deg J3: 0 mm 	J2: 60 deg J3: 0 mm 	J2: 120 deg J3: 0 mm

Description of legend:

The graph is shown for each Weight value (at 100%, approx. 66%, and approx. 33% of the maximum payload, and at the rated payload).

- Horizontal axis : Arm speed (Speed value)
- Vertical axis : Stopping time and stopping distance in each arm speed
- Time [sec] : Stopping time
- Distance [deg] : Stopping distance of J1 and J2
- Distance [mm] : Stopping distance of J3

RS3 Stopping time and Stopping distance in Emergency

RS3-351*: J1

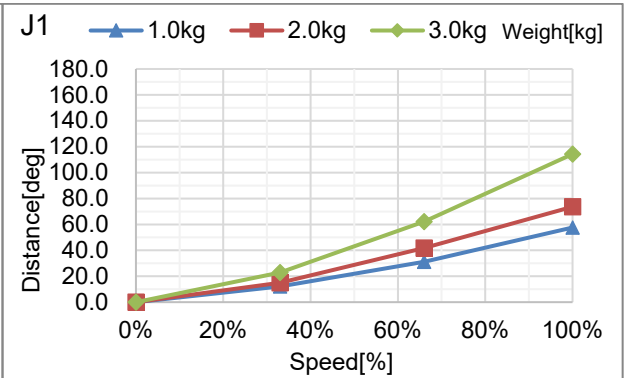
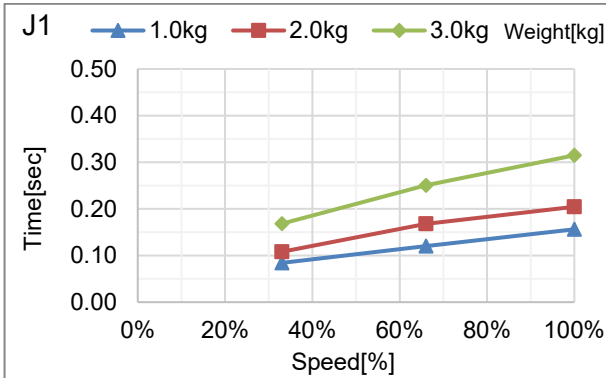

RS3-351*: J2

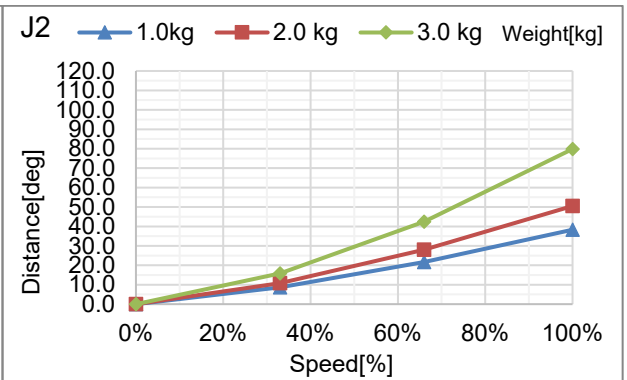
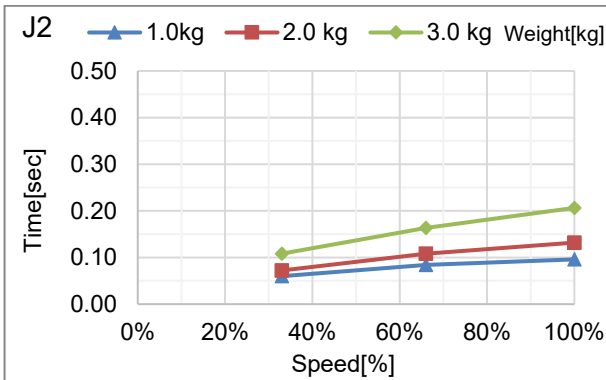

RS3-351*: J3

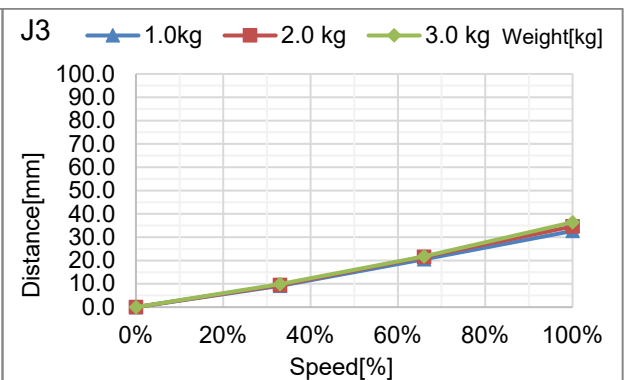
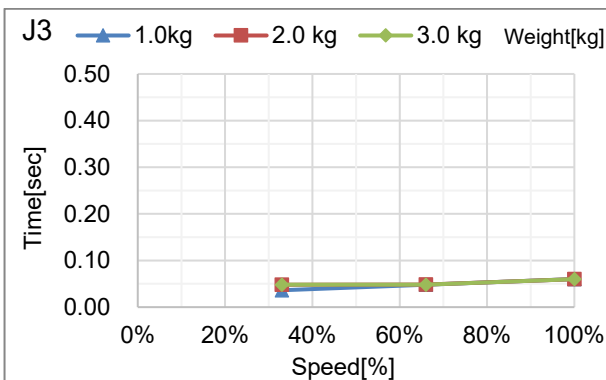

RS4 Stopping time and Stopping distance in Emergency

RS4-551*: J1

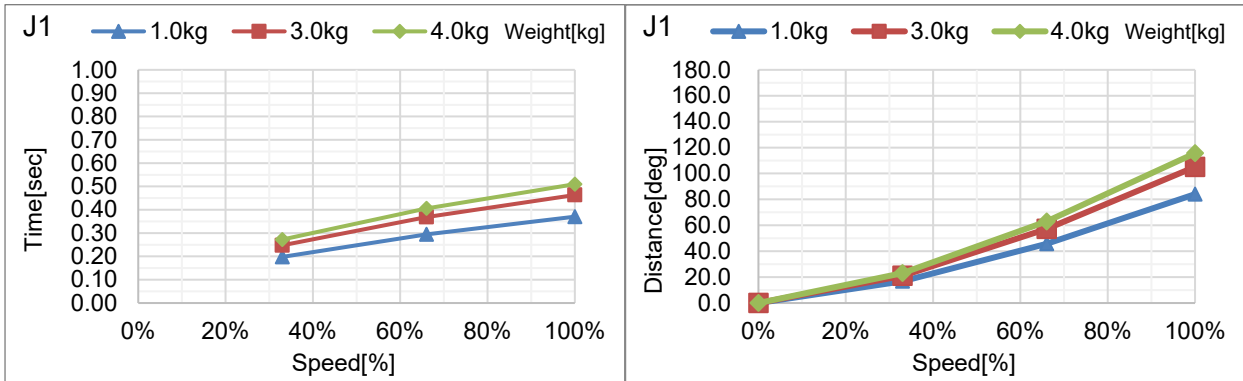

RS4-551*: J2

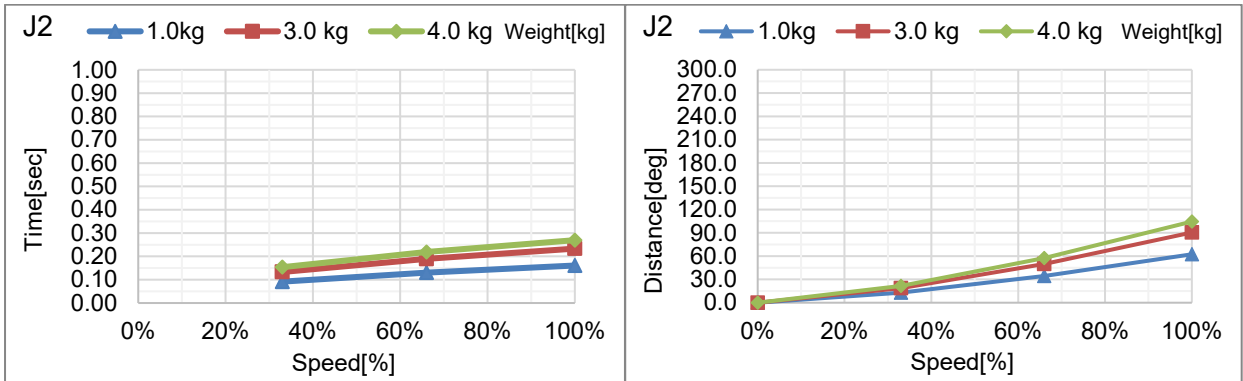

RS4-551*: J3

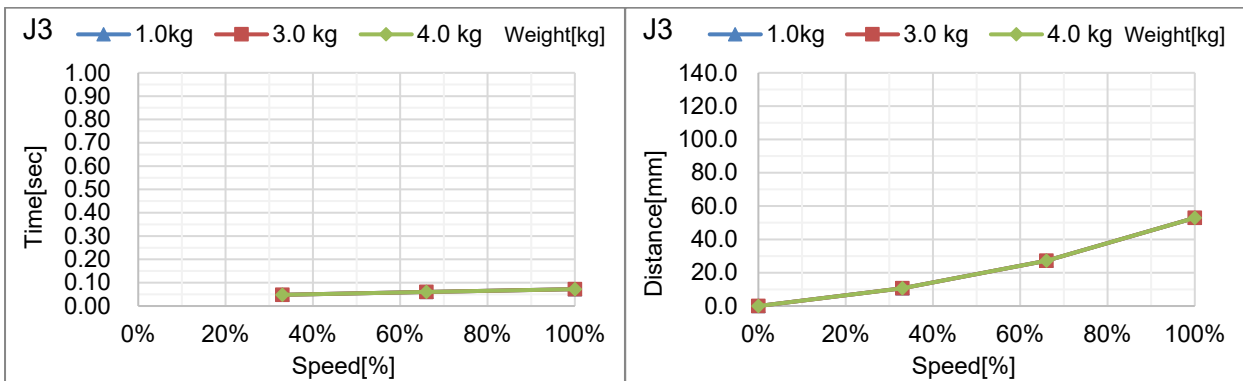

Supplementary Information regarding the Stopping Time and Stopping Distance at Emergency Stop

The stopping time and stopping distance described in Appendix B was measured by the motion determined by us based on the ISO 10218-1.

Therefore, it does not guarantee the maximum value of the stopping time and stopping distance in the customer's environment.

The stopping time and stopping distance differs depending on the robot's model, motion, and input timing of the stop signal. Make sure to always measure the stopping time and stopping distance that matches the customer's environment.



The following are included in the robot's motion and parameter.

- The motion's starting point, target point, and relay point
- Motion commands (Go, Move, Jump commands etc.)
- Weight and Inertia Settings
- Motion speed, acceleration, deceleration, and one where the motion timing changes

Also, refer to the following description.

“4.3 Weight and Inertia Settings“

“4.4 Precautions for Auto Acceleration/Deceleration of Joint #3 “

How to check the stopping time and stopping distance in the customer's environment

Measure the stopping time and stopping distance of the actual motion with the following method.

1. Create a motion program in the customer's environment.
2. After the motion to check the stopping time and stopping distance starts, input the stop signal at your own timing.
3. Record the time and distance from when the stop signal was input until the robot stopped.
4. Check the maximum stopping time and stopping distance by repeating 1 through 3 mentioned above.

- How to input the stop signal: Operate the stop switch manually or input the stop signal with the safety PLC.

- How to measure the stopping position: Measure with a tape measure. The angle could also be measured with the Where or RealPos command.

- How to measure the stopping time: Measure with a stop watch. The Tmr function can also be used to measure the stopping time.

 CAUTION	<ul style="list-style-type: none"> ■ The stopping time and stopping distance changes depending on the timing the stop signal is input. <p>In order to prevent collision with people or objects, perform a risk assessment based on the maximum stopping time and stopping distance and perform an equipment design.</p> <p>Therefore, make sure to measure the maximum value by changing the timing of the stop signal input during the actual motion and measure repeatedly.</p>
---	--

Commands that can be useful when measuring stopping time and stopping distance

Commands	Functions
Where	Returns the data of the robot's current position.
RealPos	Returns the current position of the specified robot *Unlike the motion target position of the CurPos, this obtains the position of the actual robot from the encoder in real time.
PAgl	Returns by calculating the Joint position from the specified coordinate value. P1 = RealPos 'Obtain the current position Joint1 = PAgl(P1, 1) ' Request the J1 angle from the current position
Tmr	The Tmr function returns the elapsed time from when the timer starts in seconds.
Xqt	Runs the program specified with the function name and complete the task. The function used to measure the stopping time and stopping distance should be used to run tasks that were launched by attaching the NoEmgAbort options. You can run a task that does not stop with the emergency stop and safeguard open.

For more information, refer to the following manual.

"Epson RC+ SPEL+ Language Reference"

Appendix C: Stopping time and Stopping distance When Safeguard Is Opened

The stopping time and stopping distance when safeguard is opened are shown in a graph for each model.

The stopping time is “Stopping time” in the figure below. Be sure to confirm that safety is ensured according to the installation environment and operation of the robot.

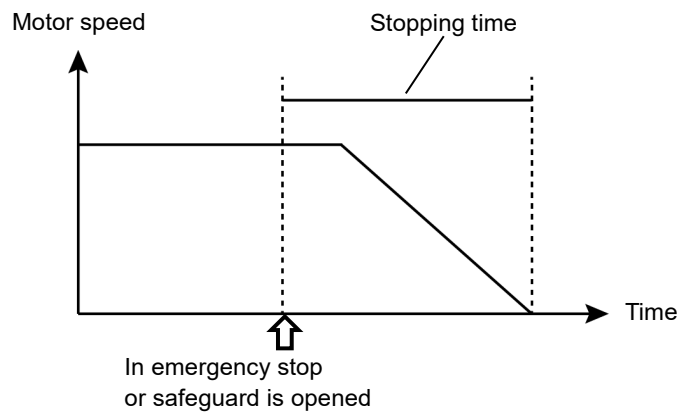

Condition:

The stopping time and stopping distance vary depending on the parameters (setting value) set for the robot. In this chapter, the time and distance are shown with the following parameters.

These conditions are based on the ISO 10218-1:2011 Annex B.

Accel : 100 ,100

Speed: 100 %, 66 %, 33 %Settings

Weight: 100 %, 66 %, 33 % of the maximum payload, rated payload

Arm elongation rate: 100 %, 66 %, 33 % *1

Other : Default

Motion: Singular axis motion of a Go command

Input timing of the Stop signal: input with maximum speed. In this motion, it is the center of the motion range.

*1 Arm elongation rate

When J1 is operating, the arm elongation rate θ is as shown in the figure below.

Among the following arm elongation rate, the graph shows the results with the longest stopping time and stopping distance.

When J2 is operating, J3 is 0 mm.

Axis	$\theta = 100\%$	$\theta = 66\%$	$\theta = 33\%$
J1	J2: 0 deg J3: 0 mm 	J2: 60 deg J3: 0 mm 	J2: 120 deg J3: 0 mm

Description of legend:

The graph is shown for each Weight value (at 100%, approx. 66%, and approx. 33% of the maximum payload, and at the rated payload).

- Horizontal axis : Arm speed (Speed value)
- Vertical axis : Stopping time and stopping distance in each arm speed
- Time [sec] : Stopping time
- Distance [deg] : Stopping distance of J1 and J2
- Distance [mm] : Stopping distance of J3

RS3 Stopping time and Stopping distance When Safeguard Is Opened

RS3-351*: J1

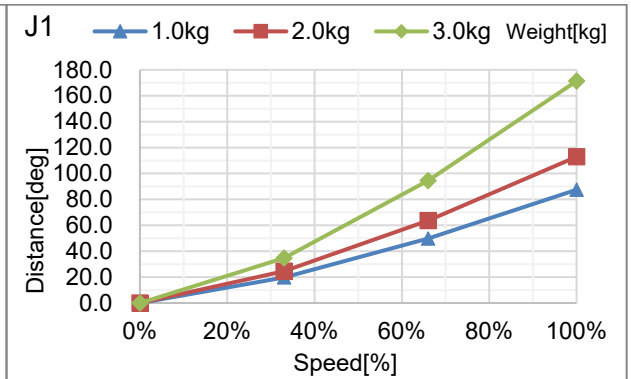
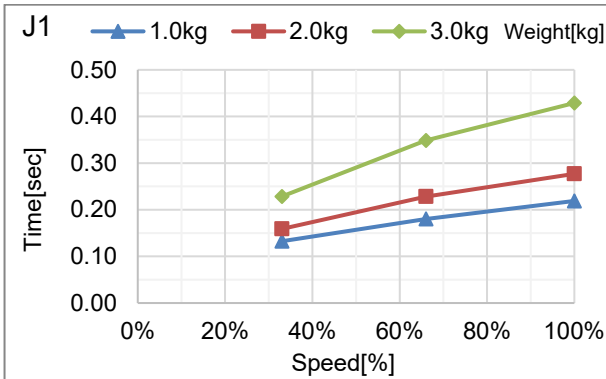

RS3-351*: J2

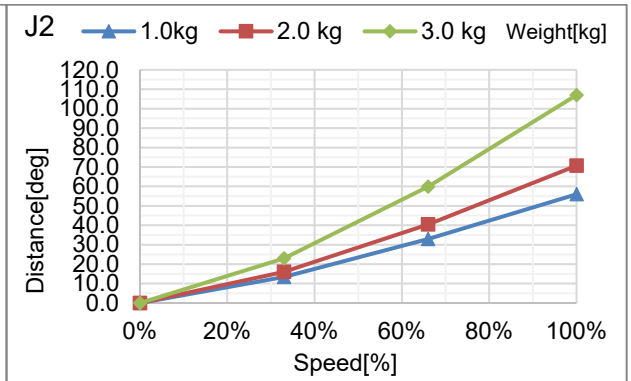
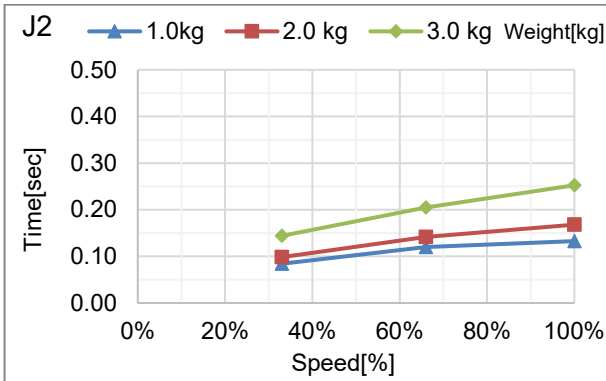

RS3-351*: J3

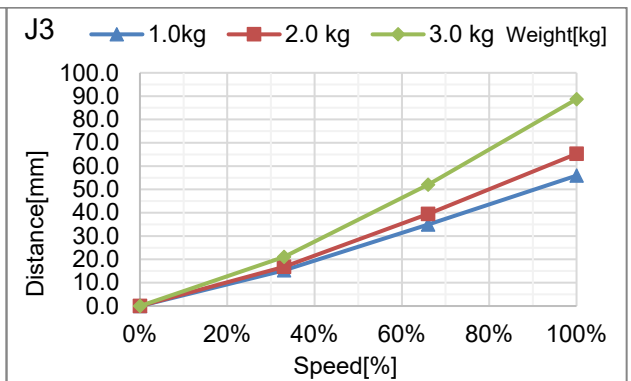
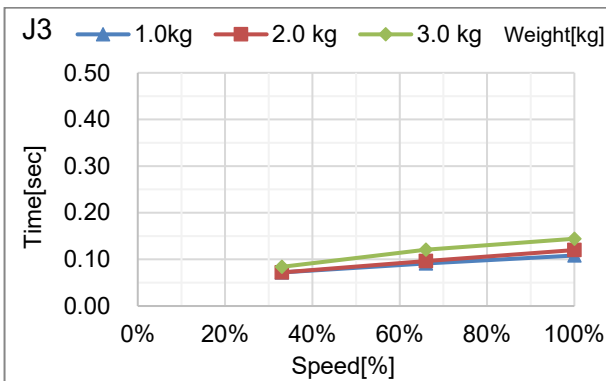

RS4 Stopping time and Stopping distance When Safeguard Is Opened

RS4-551*: J1

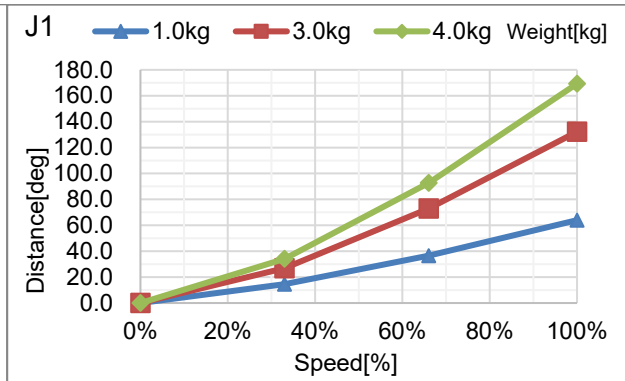
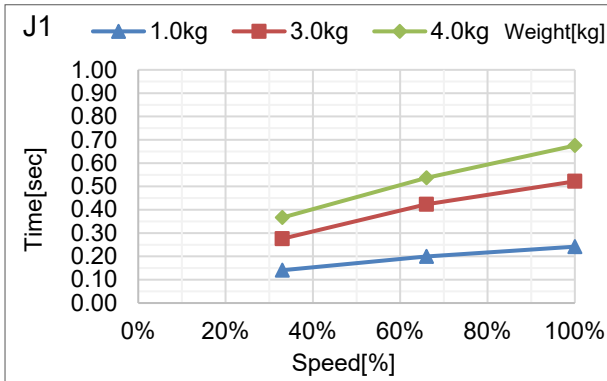

RS4-551*: J2

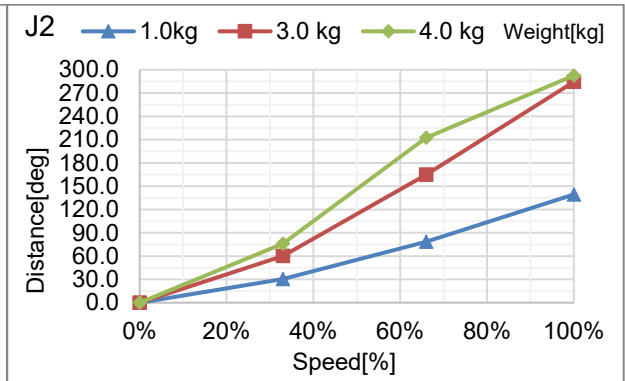
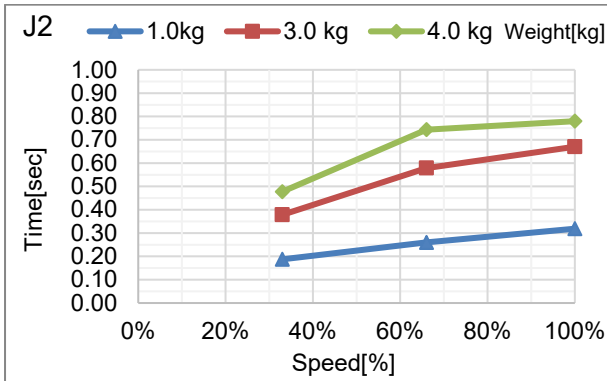

RS4-551*: J3

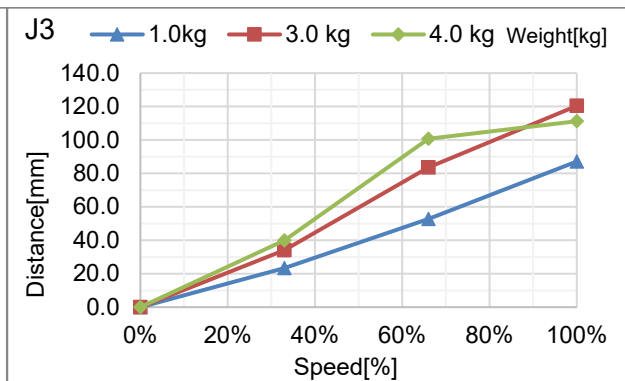
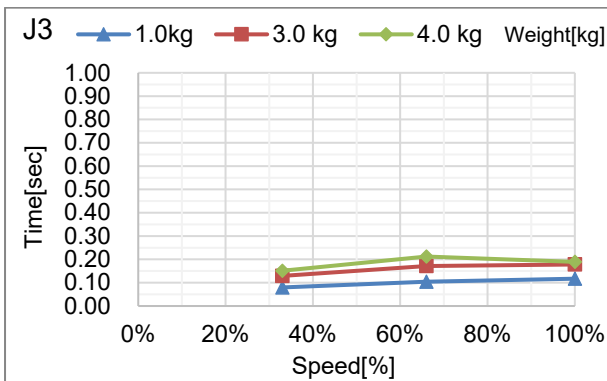

Supplementary Information regarding the Stopping Time and Stopping Distance when the Safeguard is Open

The stopping time and stopping distance described in Appendix C was measured by the motion determined by us based on the ISO 10218-1.

Therefore, it does not guarantee the maximum value of the stopping time and stopping distance in the customer's environment.

The stopping time and stopping distance differs depending on the robot's model, motion, and input timing of the stop signal. Make sure to always measure the stopping time and stopping distance that matches the customer's environment.

NOTE



The following are included in the robot's motion and parameter.

- The motion's starting point, target point, and relay point
- Motion commands (Go, Move, Jump commands etc.)
- Weight and Inertia Settings
- Motion speed, acceleration, deceleration, and one where the motion timing changes

Also, refer to the following description.

“4.3 Weight and Inertia Settings“

“4.4 Precautions for Auto Acceleration/Deceleration of Joint #3 “

How to check the stopping time and stopping distance in the customer's environment

Measure the stopping time and stopping distance of the actual motion with the following method.

1. Create a motion program in the customer's environment.
2. After the motion to check the stopping time and stopping distance starts, input the stop signal at your own timing.
3. Record the time and distance from when the stop signal was input until the robot stopped.
4. Check the maximum stopping time and stopping distance by repeating 1 through 3 mentioned above.

- How to input the stop signal: Operate the stop switch/safeguard manually or input the stop signal with the safety PLC.

- How to measure the stopping position: Measure with a tape measure. The angle could also be measured with the Where or RealPos command.

- How to measure the stopping time: Measure with a stop watch. The Tmr function can also be used to measure the stopping time.

 CAUTION	<ul style="list-style-type: none"> ■ The stopping time and stopping distance changes depending on the timing the stop signal is input. <p>In order to prevent collision with people or objects, perform a risk assessment based on the maximum stopping time and stopping distance and perform an equipment design.</p> <p>Therefore, make sure to measure the maximum value by changing the timing of the stop signal input during the actual motion and measure repeatedly.</p>
---	--

Commands that can be useful when measuring stopping time and stopping distance

Commands	Functions
Where	Returns the data of the robot's current position.
RealPos	Returns the current position of the specified robot *Unlike the motion target position of the CurPos, this obtains the position of the actual robot from the encoder in real time.
PAgl	Returns by calculating the Joint position from the specified coordinate value. P1 = RealPos 'Obtain the current position Joint1 = PAgl(P1, 1) ' Request the J1 angle from the current position
Tmr	The Tmr function returns the elapsed time from when the timer starts in seconds.
Xqt	Runs the program specified with the function name and complete the task. The function used to measure the stopping time and stopping distance should be used to run tasks that were launched by attaching the NoEmgAbort options. You can run a task that does not stop with the emergency stop and safeguard open.

For more information, refer to the following manual.

"Epson RC+ SPEL+ Language Reference"