

EPSON

Industrial Robot: 6-Axis Robots

N series

Manual

Rev.10

ENM263R8495F

Original instructions

Industrial Robot: 6-Axis Robots

N series Manual

Rev.10

©Seiko Epson Corporation 2021-2026

FOREWORD

Thank you for purchasing our robot products.

This manual contains the information necessary for the correct use of the manipulator.

Please carefully read this manual and other related manuals before installing the robot system.

Keep this manual handy for easy access at all times.

The robot system and its optional parts are shipped to our customers only after being subjected to the strictest quality controls, tests, and inspections to certify its compliance with our high performance standards. Please note that the basic performance of the product will not be exhibited if our robot system is used outside of the usage conditions and product specifications described in the manuals.

This manual describes possible dangers and consequences that we can foresee. Be sure to comply with safety precautions on this manual to use our robot system safely and correctly.

TRADEMARKS

Microsoft, Windows, and Windows logo are either registered trademarks or trademarks of Microsoft Corporation in the United States and/or other countries. Other brand and product names are trademarks or registered trademarks of the respective holders.

NOTICE

No part of this manual may be copied or reproduced without authorization.

The contents of this manual are subject to change without notice.

Please notify us if you should find any errors in this manual or if you have any comments regarding its contents.

MANUFACTURER

SEIKO EPSON CORPORATION

CONTACT INFORMATION

Contact information is described in “SUPPLIERS” in the first pages of the following manual:

Robot System Safety Manual Read this manual first

DISPOSAL

When disposing this product, dispose in accordance with the laws and regulations of each country.

Regarding battery disposal

The battery removal/replacement procedure is described in the following manuals:
Maintenance Manual

For European Union customers only



The crossed out wheeled bin label that can be found on your product indicates that this product and incorporated batteries should not be disposed of via the normal household waste stream. To prevent possible harm to the environment or human health please separate this product and its batteries from other waste streams to ensure that it can be recycled in an environmentally sound manner. For more details on available collection facilities please contact your local government office or the retailer where you purchased this product. Use of the chemical symbols Pb, Cd or Hg indicates if these metals are used in the battery.

This information only applies to customers in the European Union, according to DIRECTIVE 2006/66/EC OF THE EUROPEAN PARLIAMENT AND OF THE COUNCIL OF 6 September 2006 on batteries and accumulators and waste batteries and accumulators and repealing Directive 91/157/EEC and legislation transposing and implementing it into the various national legal systems.

For other countries, please contact your local government to investigate the possibility of recycling your product.

For Users in Taiwan region



Please separate used batteries from other waste streams to ensure that it can be recycled in an environmentally sound manner. For more details on available collection facilities please contact your local government office or the retailer where you purchased this product.

Regarding battery disposal



The crossed out wheeled bin label that can be found on your product indicates that this product and incorporated batteries should not be disposed of via the normal household waste stream. To prevent possible harm to the environment or human health please separate this product and its batteries from other waste streams to ensure that it can be recycled in an environmentally sound manner. For more details on available collection facilities please contact your local government office or the retailer where you purchased this product. Use of the chemical symbols Pb, Cd or Hg indicates if these metals are used in the battery.

This information only applies to customers in the European Union, according to DIRECTIVE 2006/66/EC OF THE EUROPEAN PARLIAMENT AND OF THE COUNCIL OF 6 September 2006 on batteries and accumulators and waste batteries and accumulators and repealing Directive 91/157/EEC and legislation transposing and implementing it into the various national legal systems.

For other countries, please contact your local government to investigate the possibility of recycling your product.

The battery removal/replacement procedure is described in the following manuals:

Maintenance Manual

Before Reading This Manual

This section describes what you should know before reading this manual.

Structure of Control System

N2 series Manipulators can be used with the following combinations of Controllers and software.

Controller : RC700-A

Software : EPSON RC+ 7.0 Ver.7.2.0 or later, Epson RC+ 8.0

N6 series Manipulators can be used with the following combinations of Controllers and software.

Controller : RC700-A

Software : EPSON RC+ 7.0 Ver.7.3.4 or later, Epson RC+ 8.0

Setting by Software

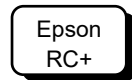

This manual contains setup procedures using the software.
Those sections are indicated by the symbol on the left.

Turning ON/OFF Controller

When you see the instruction “Turn ON/OFF the Controller” in this manual, be sure to turn ON/OFF all the hardware components.

Photos and Illustrations Used in This Manual

The appearance of some parts may differ from those on an actual product depending on when it was shipped or the specifications. The procedures themselves, however, are accurate.

The Manuals of This Product

The following are typical manual types for this product and an outline of the descriptions.

Safety Manual

This manual contains safety information for all people who handle this product. The manual also describes the process from unpacking to operation and the manual you should look at next.

Read this manual first.

- Safety precautions regarding robot system and residual risk
- Declaration of conformity
- Training
- Flow from unpacking to operation

RC700 series Manual

This manual explains the installation of the entire robot system and the specifications and functions of the controller. The manual is primarily intended for people who design robot systems.

- The installation procedure of the robot system (specific details from unpacking to operation)
- Daily inspection of the controller
- Controller specifications and basic functions

N series Manual

This manual describes the specifications and functions of the Manipulator. The manual is primarily intended for people who design robot systems.

- Technical information, functions, specifications, etc. required for the Manipulator installation and design
- Daily inspection of the Manipulator

Status Code/Error Code List

This manual contains a list of code numbers displayed on the controller and messages displayed in the software message area. The manual is primarily intended for people who design robot systems or do programming.

RC700 series Maintenance Manual

N series Maintenance Manual

This manual describes the details of maintenance etc. The manual is intended for people who perform maintenance.

- Daily inspection
- Replacement and repair of maintenance parts
- The method of firmware update and controller setting backup etc.

Epson RC+ User's Guide

This manual describes general information about program development software.

Epson RC+ SPEL+ Language Reference

This manual describes the robot programming language “SPEL+”.

Other Manual

Manuals for each option are available.

N2 Manipulator

1. Safety	3
1.1 Conventions	3
1.2 Design and Installation Safety	4
1.3 Operation Safety	5
1.4 Emergency Stop	7
1.5 Safeguard	9
1.6 How to Move Arms with the Solenoid Brake	10
1.7 Precaution for Operation in Low Power Status	11
1.8 Warning Labels	12
1.9 Response for Emergency or Malfunction	14
1.9.1 Collision	14
1.9.2 Getting body caught in Manipulator	14
2. Specifications	16
2.1 Model Number	16
2.2 Part Names	17
2.3 Outer Dimensions	18
2.3.1 S/N: N201000001~N201010000	18
2.3.2 S/N: N201010001 or later	19
2.4 Standard Motion Range	20
2.5 Specifications	21
2.5.1 Specifications table	21
2.5.2 Option	21
2.6 How to Set the Model	22
3. Environment and Installation	23
3.1 Environmental Conditions	23
3.2 Unpacking, Transportation, and Relocation	24
3.3 Mounting Dimensions	27
3.4 Installation	28
3.5 Base Table	30
3.6 Connecting the Cables	33
3.7 User Wires and Pneumatic Tubes	34
Electrical wires	35
Pneumatic tubes	35
3.8 Checking the Basic Orientation	36
4. End Effectors	37
4.1 Attaching an End Effector	37
4.2 Attaching Camera and Air Valves	38
4.3 WEIGHT and INERTIA Settings	39
4.3.1 WEIGHT setting	40
4.3.2 INERTIA setting	43
4.4 Precautions for Auto Acceleration/Deceleration	47

5. Motion Range	48
5.1 Motion Range Setting by Pulse Range (for Each Joint)	48
5.1.1 Max. Pulse Range of Joint #1	49
5.1.2 Max. Pulse Range of Joint #2	49
5.1.3 Max. Pulse Range of Joint #3	50
5.1.4 Max. Pulse Range of Joint #4	50
5.1.5 Max. Pulse Range of Joint #5	51
5.1.6 Max. Pulse Range of Joint #6	51
5.2 Restriction of Manipulator Operation.....	52
5.3 Coordinate System	54
5.4 Changing the Robot.....	55
5.5 Setting the Cartesian (Rectangular) Range in the XY CoordinateSystem of the Manipulator	56
6. Options	58
6.1 Brake Release Unit	58
Power Cable	59
Mount the brake release unit	60
Remove the brake release unit	61
How to use the brake release unit	62
6.2 Camera Plate Unit.....	63
6.3 Tool Adapter (ISO Flange)	66
6.4 User Wires	67
Included items.....	67
6.5 Wiring Guide	68
6.6 Table Top Mount Bracket.....	69
6.7 Calibration Plate.....	71

N6 Manipulator

1. Safety	75
1.1 Conventions	75
1.2 Design and Installation Safety	76
1.3 Operation Safety	77
1.4 Emergency Stop	79
1.5 Safeguard	81
1.6 How to Move Arms with the Electromagnetic Brake	82
Arm Motion	83
1.7 Precaution for Operation in Low Power Status	84
1.8 Warning Labels	85
Location of Labels:	86
1.9 Response for Emergency or Malfunction	88
1.9.1 Collision	88
1.9.2 Getting body caught in Manipulator	88
2. Specifications	91
2.1 Model Number	91
2.2 Part Names	92
2.3 Outer Dimensions	95
2.3.1 Basic Orientation	95
2.3.2 Orientation with the Maximum Arm Length	98
2.4 Standard Motion Range	99
2.5 Specifications	101
2.5.1 Specifications table	101
2.5.2 Option	101
2.6 How to Set the Model	102
3. Environment and Installation	103
3.1 Environmental Conditions	103
3.2 Unpacking, Transportation, and Relocation	105
3.3 Mounting Dimensions	109
3.3.1 Mounting Area	109
3.3.2 Mounting dimensions	109
3.3.3 Motion range	111
3.4 Installation	115
3.5 Base Table	118
3.6 Connecting the Cables	120
3.7 User Wires and Pneumatic Tubes	122
Electrical wires	123
Pneumatic tubes	123
3.8 Checking the Basic Orientation	124
4. End Effectors	126
4.1 Attaching an End Effector	126
4.2 Attaching Camera and Air Valves	127

4.3	WEIGHT and INERTIA Settings	129
4.3.1	WEIGHT setting	130
4.3.2	INERTIA setting.....	133
4.4	Precautions for Auto Acceleration/Deceleration	137
5. Motion Range		138
5.1	Motion Range Setting by Pulse Range (for Each Joint)	138
5.1.1	Max. Pulse Range: N6-A1000**	139
5.1.2	Max. Pulse Range: N6-A850**R	142
5.2	Restriction of Manipulator Operation.....	145
5.3	Coordinate System	149
5.4	How to Use Orientation Flag	150
	N6-A1000**	150
	Command: "AutoOrientationFlag"	151
5.5	Changing the Robot	152
5.6	Setting the Cartesian (Rectangular) Range in the XY Coordinate System of the Manipulator	153
6. Options		155
6.1	Brake Release Unit	155
	Power Cable	156
	Mount the brake release unit	158
	Remove the brake release unit	159
	How to use the brake release unit	160
6.2	Camera Plate Unit.....	161
6.4	User Wiring	165
6.5	M/C Cable	165

Regular Inspection

1. Regular Inspection for N2 Manipulator	169
1.1 Inspection	169
1.1.1 Schedule for Inspection	169
1.1.2 Inspection Point	170
1.2 Overhaul (Parts Replacement)	172
1.3 Greasing	172
1.4 Tightening Hexagon Socket Head Bolts	172
2. Regular Inspection for N6 Manipulator	173
2.1 Inspection	173
2.1.1 Schedule for Inspection	173
2.1.2 Inspection Point	174
2.2 Overhaul (Parts Replacement)	176
2.3 Greasing	176
2.4 Tightening Hexagon Socket Head Bolts	176

Appendix

Appendix A: Specifications	179
N2 Specifications	179
N6 Specifications	182
Appendix B: Stopping time and Stopping distance in Emergency	186
N2 Stopping time and Stopping distance in Emergency	188
N2-A450S*: J1 (Table Top mounting, Ceiling mounting)	188
N2-A450S*: J2 (Table Top mounting, Ceiling mounting)	188
N2-A450S*: J3 (Table Top mounting, Ceiling mounting)	188
N2-A450S*: J4 (Table Top mounting, Ceiling mounting)	189
N2-A450S*: J5 (Table Top mounting, Ceiling mounting)	189
N2-A450S*: J6 (Table Top mounting, Ceiling mounting)	189
N6 Stopping time and Stopping distance in Emergency	190
N6-A850**R: J1 (Ceiling mounting)	190
N6-A850**R: J2 (Ceiling mounting)	190
N6-A850**R: J3 (Ceiling mounting)	190
N6-A850**R: J4 (Ceiling mounting)	191
N6-A850**R: J5 (Ceiling mounting)	191
N6-A850**R: J6 (Ceiling mounting)	191
N6-A1000**: J1 (Table Top mounting, Ceiling mounting)	192
N6-A1000**: J2 (Table Top mounting, Ceiling mounting)	192
N6-A1000**: J3 (Table Top mounting, Ceiling mounting)	192
N6-A1000**: J4 (Table Top mounting, Ceiling mounting)	193
N6-A1000**: J5 (Table Top mounting, Ceiling mounting)	193
N6-A1000**: J6 (Table Top mounting, Ceiling mounting)	193
Supplementary Information regarding the Stopping Time and Stopping Distance at Emergency Stop	194
How to check the stopping time and stopping distance in the customer's	

environment 194
 Commands that can be useful when measuring stopping time and stopping
 distance 195

**Appendix C: Stopping time and Stopping distance When Safeguard Is
 Opened 196**

N2 Stopping time and Stopping distance When Safeguard Is Opened 198
 N2-A450S*: J1 (Table Top mounting, Ceiling mounting) 198
 N2-A450S*: J2 (Table Top mounting, Ceiling mounting) 198
 N2-A450S*: J3 (Table Top mounting, Ceiling mounting) 198
 N2-A450S*: J4 (Table Top mounting, Ceiling mounting) 199
 N2-A450S*: J5 (Table Top mounting, Ceiling mounting) 199
 N2-A450S*: J6 (Table Top mounting, Ceiling mounting) 199
 N6 Stopping time and Stopping distance When Safeguard Is Opened 200
 N6-A850**R: J1 (Ceiling mounting) 200
 N6-A850**R: J2 (Ceiling mounting) 200
 N6-A850**R: J3 (Ceiling mounting) 200
 N6-A850**R: J4 (Ceiling mounting) 201
 N6-A850**R: J5 (Ceiling mounting) 201
 N6-A850**R: J6 (Ceiling mounting) 201
 N6-A1000**: J1 (Table Top mounting, Ceiling mounting) 202
 N6-A1000**: J2 (Table Top mounting, Ceiling mounting) 202
 N6-A1000**: J3 (Table Top mounting, Ceiling mounting) 202
 N6-A1000**: J4 (Table Top mounting, Ceiling mounting) 203
 N6-A1000**: J5 (Table Top mounting, Ceiling mounting) 203
 N6-A1000**: J6 (Table Top mounting, Ceiling mounting) 203
 Supplementary Information regarding the Stopping Time and Stopping
 Distance when the Safeguard is Open 204
 How to check the stopping time and stopping distance in the customer's
 environment 204
 Commands that can be useful when measuring stopping time and stopping
 distance 205

N2 Manipulator

This volume contains information for setup and operation of the Manipulators.
Please read this volume thoroughly before setting up and operating the Manipulators.

1. Safety



Unpacking, and transportation of the Manipulators and robotic equipment shall be performed by personnel who has taken robot system training held by us and suppliers and should conform to all national and local codes.

Please read this manual and other related manuals before installing the robot system or before connecting cables.

Keep this manual handy for easy access at all times.

1.1 Conventions

Important safety considerations are indicated throughout the manual by the following symbols. Be sure to read the descriptions shown with each symbol.

 WARNING	This symbol indicates that a danger of possible serious injury or death exists if the associated instructions are not followed properly.
 WARNING	This symbol indicates that a danger of possible serious injury caused by electric shock exists if the associated instructions are not followed properly.
 CAUTION	This symbol indicates that a danger of possible harm to people or physical damage to equipment and facilities exists if the associated instructions are not followed properly.

1.2 Design and Installation Safety

This product is intended for transporting and assembling parts in a safely isolated area. Design and installation of robot system shall be performed by personnel who has taken robot system training held by us and suppliers.

To ensure safety, a safeguard must be installed for the robot system. For details on the safeguard, refer to the *Installation and Design Precautions* in the *Safety* chapter of the Epson RC+ User’s Guide.



The following items are safety precautions for design personnel:

 WARNING	<ul style="list-style-type: none"> ■ Personnel who design and/or construct the robot system with this product must read “<i>Safety Manual</i>”. Designing and/or constructing the robot system without understanding the safety requirements is extremely hazardous, and may result in serious bodily injury and/or severe equipment damage to the robot system. ■ The Manipulator and the Controller must be used within the environmental conditions described in their respective manuals. This product has been designed and manufactured strictly for use in a normal indoor environment. Using the product in an environment that exceeds the specified environmental conditions may not only shorten the life of the product but may also cause serious safety problems. ■ The robot system must be used within the installation requirements described in the manuals. Using the robot system outside of the installation requirements may not only shorten the life of the product but also cause serious safety problems. ■ When designing or installing a robot system, wear at least the following protective gear. Working without protective gear may cause serious safety problems. <ul style="list-style-type: none"> Work clothes suitable for work Helmet Safety shoes
--	--

Further precautions for installation are described in the chapter “3. *Environment and Installation*”. Please read this chapter carefully to understand safe installation procedures before installing the robots and robotic equipment.

1.3 Operation Safety

The following items are safety precautions for qualified Operator personnel:

 WARNING	<ul style="list-style-type: none"> ■ Please carefully read “<i>Safety Manual</i>”. Operating the robot system without understanding the safety precautions is extremely hazardous and may result in serious bodily injury and/or severe equipment damage to the robot system. ■ Do not enter the operating area of the Manipulator while the power to the robot system is turned ON. Entering the operating area with the power ON is extremely hazardous and may cause serious safety problems as the Manipulator may move even if it seems to be stopped. ■ Before operating the robot system, make sure that no one is inside the safeguarded area. The robot system can be operated in the mode for teaching even when someone is inside the safeguarded area. The motion of the Manipulator is always in restricted status (low speeds and low power) to secure the safety of an operator. However, operating the robot system while someone is inside the safeguarded area is extremely hazardous and may result in serious safety problems in case that the Manipulator moves unexpectedly. ■ Immediately press the Emergency Stop switch whenever the Manipulator moves abnormally during operation. Continuing the operation while the Manipulator moves abnormally is extremely hazardous and may result in serious bodily injury and/or severe equipment change to the robot system.
 WARNING	<ul style="list-style-type: none"> ■ Be sure to connect the AC power cable to a power receptacle. DO NOT connect it directly to a factory power source. To shut off power to the robot system, disconnect the power plug from the power source. Performing any work while connecting the AC power cable to a factory power source is extremely hazardous and may result in electric shock and/or malfunction of the robot system. ■ Before performing any replacement procedure, turn OFF the Controller and related equipment, and then disconnect the power plug from the power source. Performing any replacement procedure with the power ON is extremely hazardous and may result in electric shock and/or malfunction of the robot system. ■ Do not connect or disconnect the motor connectors while the power to the robot system is turned ON. Connecting or disconnecting the motor connectors with the power ON is extremely hazardous and may result in serious bodily injury as the Manipulator may move abnormally, and also may result in electric shock and/or malfunction of the robot system.



CAUTION

- Whenever possible, only one person should operate the robot system. If it is necessary to operate the robot system with more than one person, ensure that all people involved communicate with each other as to what they are doing and take all necessary safety precautions.
- If the joints are operated repeatedly with the operating angle less than 5 degrees, they may get damaged early because the bearings are likely to cause oil film shortage in such situation. To prevent early breakdown, move each joint larger than 30 degrees for about once an hour.
- Oscillation (resonance) may occur continuously in low speed Manipulator motion (Speed: approx. 5 to 20%) depending on combination of Arm orientation and end effector load. Oscillation arises from natural oscillation frequency of the Arm and can be controlled by following measures.

- Changing Manipulator speed
- Changing the teach points
- Changing the end effector load

1.4 Emergency Stop

If the Manipulator moves abnormally during operation, immediately press the Emergency Stop switch. Pressing the Emergency Stop switch immediately changes the Manipulator to deceleration motion and stops it at the maximum deceleration speed.

Avoid pressing the Emergency Stop switch unnecessarily while the Manipulator is running normally.

- The Manipulator may hit the peripheral equipment.

When you press the Emergency Stop switch, the operating trajectory until the robot system stops is different from that in normal operation.

- The life of the brakes will be shortened.

The brakes are locked and the brake friction plate is worn.

Normal brake life cycle: About 2 years (when the brakes are used 100 times/day)

However, the rough normal relay life is approximately 20,000 times. If you press the emergency stop switch unnecessarily, the life of the relay will be shortened.

- Impact is applied on the reduction gear unit, and it may result in the short life of the reduction gear unit.

To place the robot system in emergency mode during normal operation, press the Emergency Stop switch while the Manipulator is not moving.

Refer to the Controller manual for instructions on how to wire the Emergency Stop switch circuit.

Do not turn OFF the Controller while the Manipulator is operating.

If you attempt to stop the Manipulator in emergency situations, make sure to stop the Manipulator using the E-STOP of the Controller.

If the Manipulator is stopped by turning OFF the Controller while it is operating, the following problems may occur.

Reduction of the life and damage of the reduction gear unit

Position gap at the joints

In addition, if the Controller was forced to be turned OFF by blackouts and the like while the Manipulator is operating, make sure to check the following points after power restoration.

Whether or not the reduction gear is damaged

Whether or not the joints are in their proper positions

If there is a position gap, perform calibration by referring to “*N series Maintenance Manual-N2 Maintenance - Calibration*”.

Before using the Emergency Stop switch, be aware of the followings.

- The Emergency Stop (E-STOP) switch should be used to stop the Manipulator only in case of emergencies.
- To stop the Manipulator operating the program except in emergency, use Pause (halt) or STOP (program stop) commands.
Pause and STOP commands do not turn OFF the motors. Therefore, the brake does not function.
- For the Safeguard system, do not use the circuit for E-STOP.

To check brake problems, refer to “*Regular Inspection 1. Regular Inspection for N2 Manipulator*”.

NOTE



Test pulse cannot be used with the emergency stop input of this model.

Stopping distance in emergency

The Manipulator in operation cannot stop immediately after the Emergency Stop switch is pressed. In addition, stopping time and stopping distance vary by following factors:

Hand weight	WEIGHT Setting	ACCEL Setting
Workpiece weight	SPEED Setting	Posture etc.

For stopping time and stopping distance of the Manipulator, refer to “*Appendix B: Stopping Time and Stopping Distance in Emergency*”.

1.5 Safeguard

To ensure safe operation, install a safety system using safety doors, light curtains, safety floor mats, etc.

When a closed safeguard is open during robot motion, the safeguard interlock function operates. The robot stops immediately and enters into pause state. Then, all robot motors are turned OFF. The descriptions below explain how the safeguard input works.

Safeguard open : The robot stops immediately, motors are turned OFF, and further operation is impossible until either the safeguard is closed or TEACH or TEST mode is turned ON and the enable circuit is engaged.

Safeguard closed : The robot can automatically operate in unrestricted (high power) state.

Do not open the safeguard unnecessarily while motor is ON. Frequent safeguard inputs affect the life of the relay.

Rough normal relay life: Approximately 20,000 times

For the safeguard, do not use the E-STOP circuit.

For details of wiring instructions, refer to the following manual:

RC700 series Manual - Functions required for designing - EMERGENCY

For details of Safeguard, refer to the following manual:

RC700 series Manual - Installation - Connection to EMERGENCY Connector



Test pulse cannot be used with the safeguard input of this model.

 WARNING	<ul style="list-style-type: none"> ■ The EMERGENCY connector on the controller has a safeguard input circuit to connect the safety device interlock switch. To protect operators working near the robot, be sure to connect the interlock switch and make sure that it works properly. ■ The time to stop the robot and the stopping distance by the safeguard interlock function will change depending on the conditions of use. Be sure to confirm that safety is ensured according to the installation environment of the robot.
---	---

Stopping distance when the safeguard is opened

The Manipulator in operation cannot stop immediately after the safeguard is opened. In addition, stopping time and stopping distance vary by following factors:

Hand weight	WEIGHT Setting	ACCEL Setting
Workpiece weight	SPEED Setting	Posture etc.

For stopping time and stopping distance of the Manipulator, refer to “Appendix C: Stopping Time and Stopping Distance When the Safeguard is Opened”.

1.6 How to Move Arms with the Solenoid Brake

There are two methods to release the Solenoid brake.

Follow either method to release the Solenoid brake and move the arm manually.

The Joint #1 is not equipped with the Solenoid brake.

Moving the arm using the brake release unit:

Follow the method when you just unpack the delivered boxes or when the Controller does not start up yet.

The brake release unit is available as an option.

For details, refer to “6.Option”.

Moving the arm using the software:

Follow the method when you can use the software.



CAUTION

- Normally, release the brake of joints one by one. Take extra care if you need to release the brakes of two or more joints simultaneously. Releasing the brakes of two or more joints simultaneously may cause hands and fingers to be caught and/or equipment damage to or malfunction of the Manipulator as the arms of the Manipulator may move in unexpected directions.
- Be careful of the arm falling when releasing the brake. While the brake is being released, the Manipulator's arm falls by its own weight. The arm falling may cause hands and fingers to be caught and/or may cause equipment damage to or malfunction of the Manipulator.
- Before releasing the brake, be sure to keep the Emergency Stop switch handy so that you can immediately press the Emergency Stop switch. Otherwise, you cannot immediately stop the arm falling due to an erroneous operation. The arm falling may cause equipment damage to and/or malfunction of the Manipulator.

Epson
RC+

After releasing the Emergency Stop switch, execute the following command in [Command Window].

```
>Reset
```

```
>Brake Off, [the number (from 2 to 6) corresponding to the arm whose brake will be turned OFF]
```

Execute the following command to turn ON the brake again.

```
>Brake On, [The number (from 2 to 6) corresponding to the arm whose brake will be turned ON]
```

While the Solenoid brakes are ON (such as in emergency mode), you cannot move any arms except for Arm #1 by pushing manually.

Arm Motion

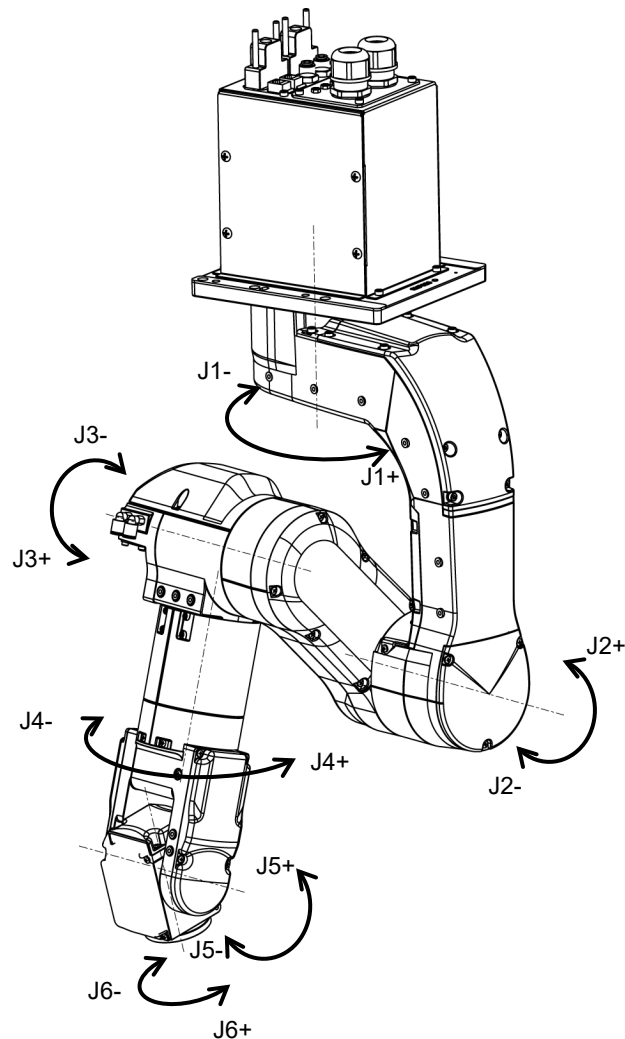

1.7 Precaution for Operation in Low Power Status

In the low power status, the Manipulator operates at low speed and low torque. However, comparatively high torque as shown in the table below may be generated to support the Manipulator's own weight.

Carefully operate the Manipulator since it may get your hands or fingers caught during operation. The Manipulator may also collide with peripheral equipment and cause equipment damage to or malfunction of the Manipulator.

Maximum Joint Torque in Low Power Status

[Unit: N·m]

Joint	#1	#2	#3	#4	#5	#6
Joint Torque	34.49	69.74	40.94	11.69	10.27	4.13



CAUTION

- Carefully operate the Manipulator in the low power status. A comparatively high joint torque may be generated. It may cause your hands and fingers caught and/or cause equipment damage to or malfunction of the Manipulator as it may collide with peripheral equipment.







1.8 Warning Labels

The Manipulator has the following warning labels.

The warning labels are attached around the locations where specific dangers exist.

Be sure to comply with descriptions and warnings on the labels to operate and maintain the Manipulator safely.

Do not tear, damage, or remove the warning labels. Use meticulous care when handling those parts or units to which the following warning labels are attached as well as the nearby areas.

Location	Warning Label	NOTE
A	 <p>警告 WARNING 警告 AVERTISSEMENT 警告 ADVERTENCIA 경고 ATENÇÃO ОСТОПЖХО</p> <p>当心落下 TIP-OVER HAZARD 当心落下 RISQUE DE BASCULEMENT 転倒の危険 PELIGRO DE VUELCO 転倒 위험 PERIGO DE QUEDA ОПАСНОСТЬ ОПРОКИДЫВАНИЯ</p>	<p>To avoid the Manipulator from falling, support the Manipulator before removing the base mounting screws.</p> <p>Follow the instructions in this manual for transportation and installation.</p>
B	 <p>警告 WARNING 警告 AVERTISSEMENT 警告 ADVERTENCIA 경고 ATENÇÃO ОСТОПЖХО</p> <p>当心碰撞 COLLISION HAZARD 当心碰撞 RISQUE DE COLLISION 衝突の危険 PELIGRO DE COLISION 충돌 위험 PERIGO DE MORTE OU FERIMENTOS GRAVES ОПАСНОСТЬ СТОЛКНОВЕНИЯ</p>	<p>Do not enter the work space when the Manipulator is operating. It is extremely hazardous since the Arm may collide and cause serious safety problems.</p>
C	 <p>警告 WARNING 警告 AVERTISSEMENT 警告 ADVERTENCIA 경고 ATENÇÃO ОСТОПЖХО</p> <p>当心触电 ELECTRIC SHOCK HAZARD 当心触电 RISQUE DE CHOC ELECTRIQUE 感電の危険 PELIGRO DE DESCARGA ELÉCTRICA 감전 위험 PERIGO DE CHOQUE ELÉTRICO ОПАСНОСТЬ ПОРАЖЕНИЯ ЭЛЕКТРИЧЕСКИМ ТОКОМ</p>	<p>Do not touch the current-carrying parts inside the Manipulator while the power is ON. It may cause electrical shock.</p>
D	 <p>警告 WARNING 警告 AVERTISSEMENT 警告 ADVERTENCIA 경고 ATENÇÃO ОСТОПЖХО</p> <p>当心夹手 CRUSH HAZARD 当心夹手 RISQUE D'ÉCRASEMENT 挟み込みの危険 PELIGRO DE APLASTAMIENTO 손잡 위험 PERIGO DE ESMAGAMENTO ОПАСНОСТЬ РАЗРАБОТКИ</p>	<p>You may get your hand or fingers caught when bringing your hand close to moving parts.</p>
E	 <p>警告 WARNING 警告 AVERTISSEMENT 警告 ADVERTENCIA 경고 ATENÇÃO ОСТОПЖХО</p> <p>当心落下 FALLING HAZARD 当心落下 RISQUE DE CHUTE 낙하의 위험 PELIGRO DE CAIDAS 낙하 위험 PERIGO DE QUEDA ОПАСНОСТЬ ПАДЕНИЯ</p>	<p>When releasing the brakes, be careful of the arm falling due to its own weight.</p> <p>This warning label is attached on the Manipulator and optional brake release unit.</p>
F	 <p>警告 WARNING 警告 AVERTISSEMENT 警告 ADVERTENCIA 경고 ATENÇÃO ОСТОПЖХО</p> <p>当心高温表面 HOT SURFACE 当心高温表面 SURFACE CHAUDE 热い表面 SUPERFICIE CALIENTE 고온 표면 SUPERFICIE QUENTE ГОРЯЧАЯ ПОВЕРХНОСТЬ</p>	<p>HOT</p> <p>Be careful not to burn yourself.</p>

Location	Label	NOTE
1	-	<p>The product name, model name, serial number, information which laws and regulations are supported, product specifications, manufacturer, importer, date of manufacture, country of manufacture, etc. are listed.</p> <p>For details, see the label affixed to the product.</p>

Location of Labels:

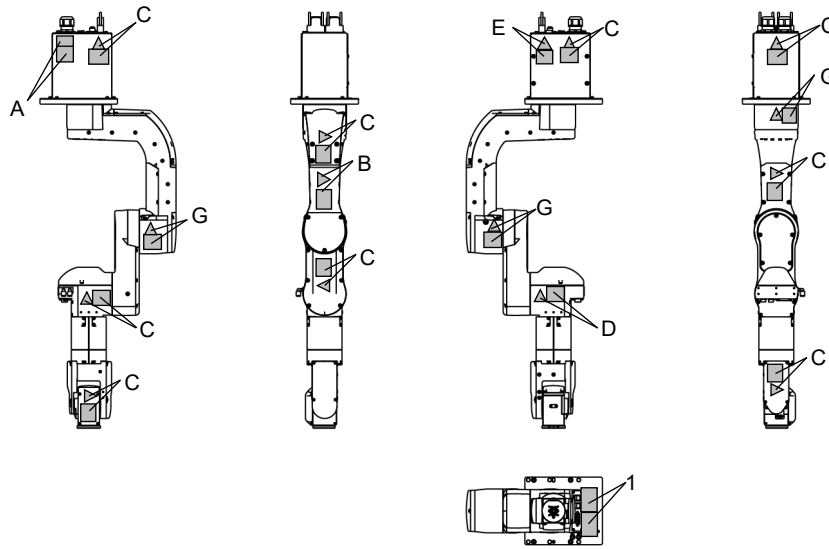

1.9 Response for Emergency or Malfunction

1.9.1 Collision

When the Manipulator collides with a mechanical stopper or peripheral device etc., discontinue use and contact the supplier.

Also, if the Manipulator collides with mechanical stops or peripheral devices, the following problems may occur.

- Reduction of the life and damage of the reduction gear unit

- Position gap at the joints

1.9.2 Getting body caught in Manipulator

When the operator is caught between the Manipulator and a mechanical part such as a base table, press the emergency stop switch to release the brake on the subject arm, and then move the arm by hand.

The Arm without brake (Arm #1):

- Move the arm by hand.

The Arm with brake (Arm #2 to #6):

- Release the brake on the subject arm, and then move the arm by hand.

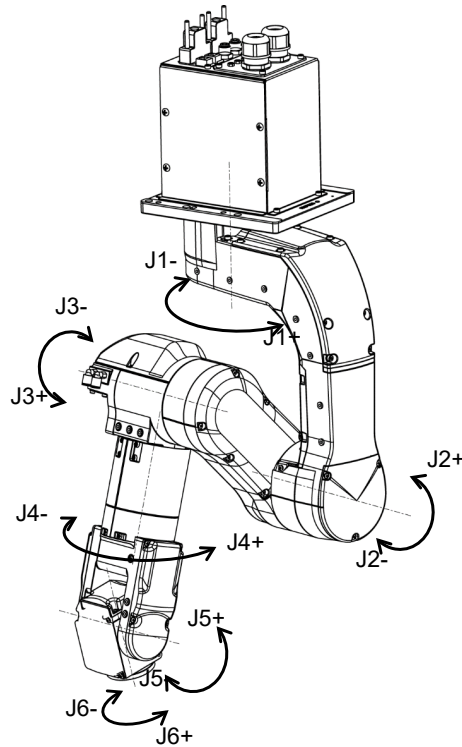

 CAUTION	<ul style="list-style-type: none"> ■ Normally, release the brake of joints one by one. Take extra care if you need to release the brakes of two or more joints simultaneously. Releasing the brakes of two or more joints simultaneously may cause hands and fingers to be caught and/or equipment damage to or malfunction of the Manipulator as the arms of the Manipulator may move in unexpected directions. ■ Be careful of the arm falling when releasing the brake. While the brake is being released, the Manipulator's arm falls by its own weight. The arm falling may cause hands and fingers to be caught and/or may cause equipment damage to or malfunction of the Manipulator.
---	---

How to release a brake

Using software:

Epson RC+ After releasing the Emergency Stop switch, execute the following command in [Command Window].

```
>Reset
```

```
>Brake Off, [ the Arm (#2 to #6) whose brake will be turned OFF]
```

Execute the following command to turn ON the brake again.

```
>Brake On, [ the Arm (#2 to #6) whose brake will be turned ON]
```

Using "Brake release unit (option)":

Refer to "*6.1 Brake Release Unit*".

2. Specifications

2.1 Model Number

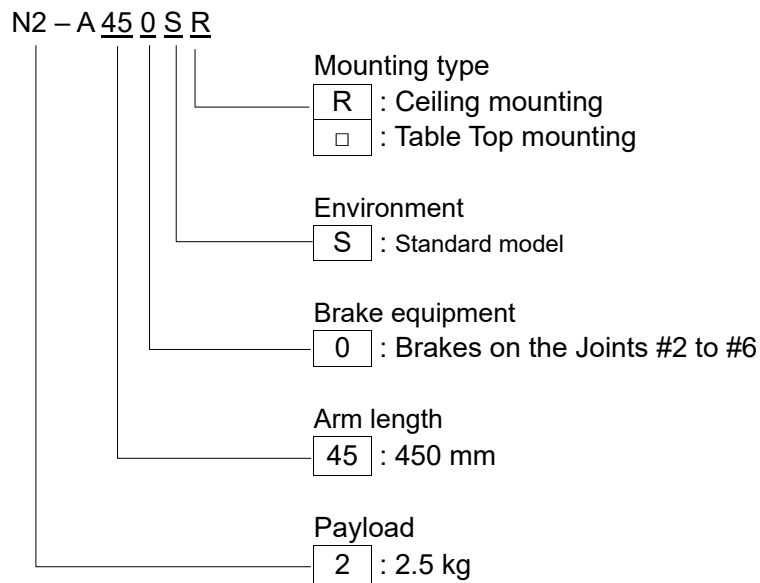

Manipulators are set to “Ceiling mounting” at shipment. To use the Manipulators as “Table Top mounting”, you need to change the model settings.

For details on how to change the model settings, refer to “5.4 Changing the Robot”, and “Epson RC+ User’s Guide Robot Configuration”.

2.2 Part Names

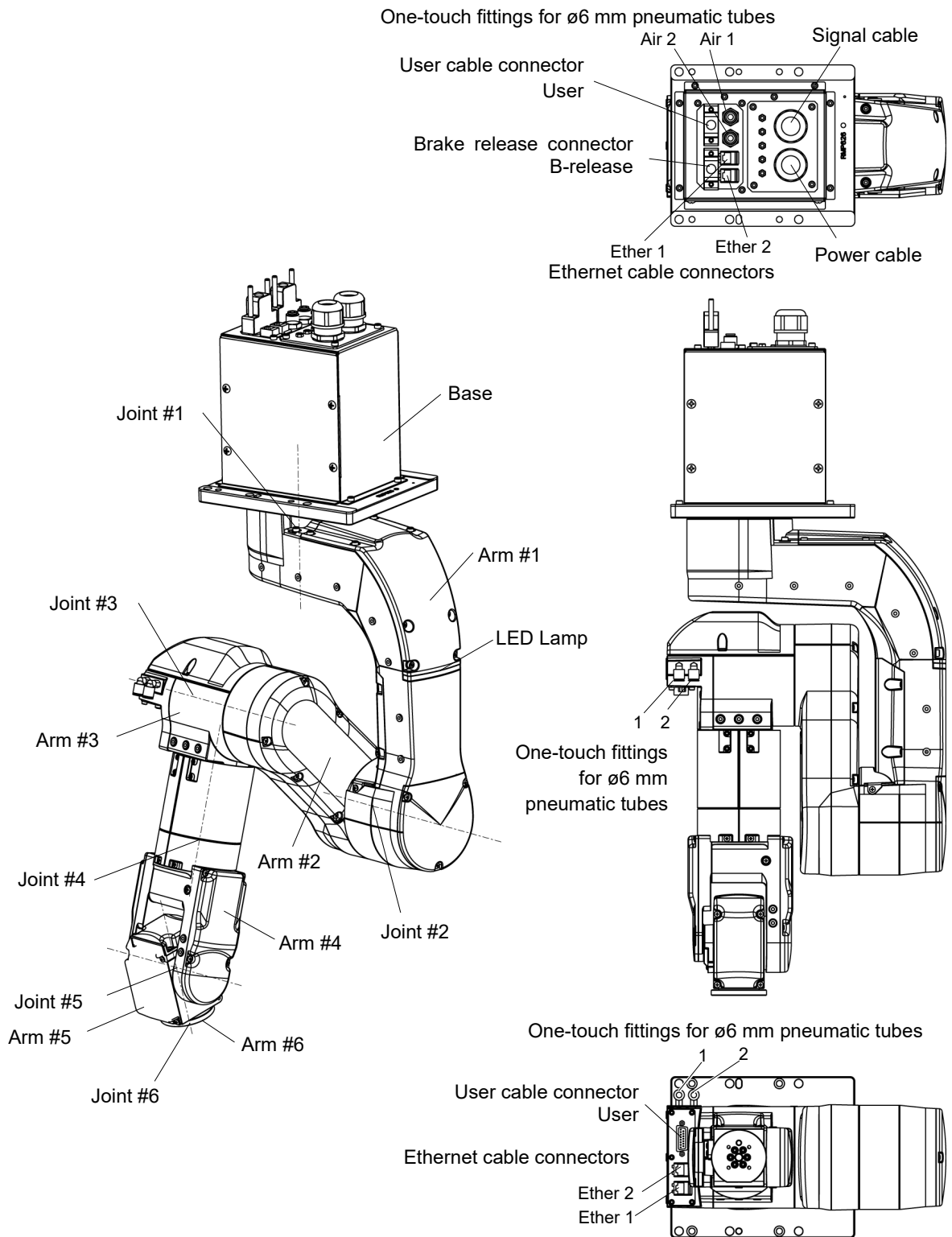

NOTE  When the LED lamp is lighting or the Controller power is on, the current is being applied to the Manipulator. (The LED lamp may not be seen depending on the Manipulator's posture. Be very careful.) Performing any work with the power ON is extremely hazardous and it may result in electric shock and/or improper function of the robot system. Make sure to turn OFF the Controller power before the maintenance work.

2.3 Outer Dimensions

[Unit: mm]

2.3.1 S/N: N201000001~N201010000

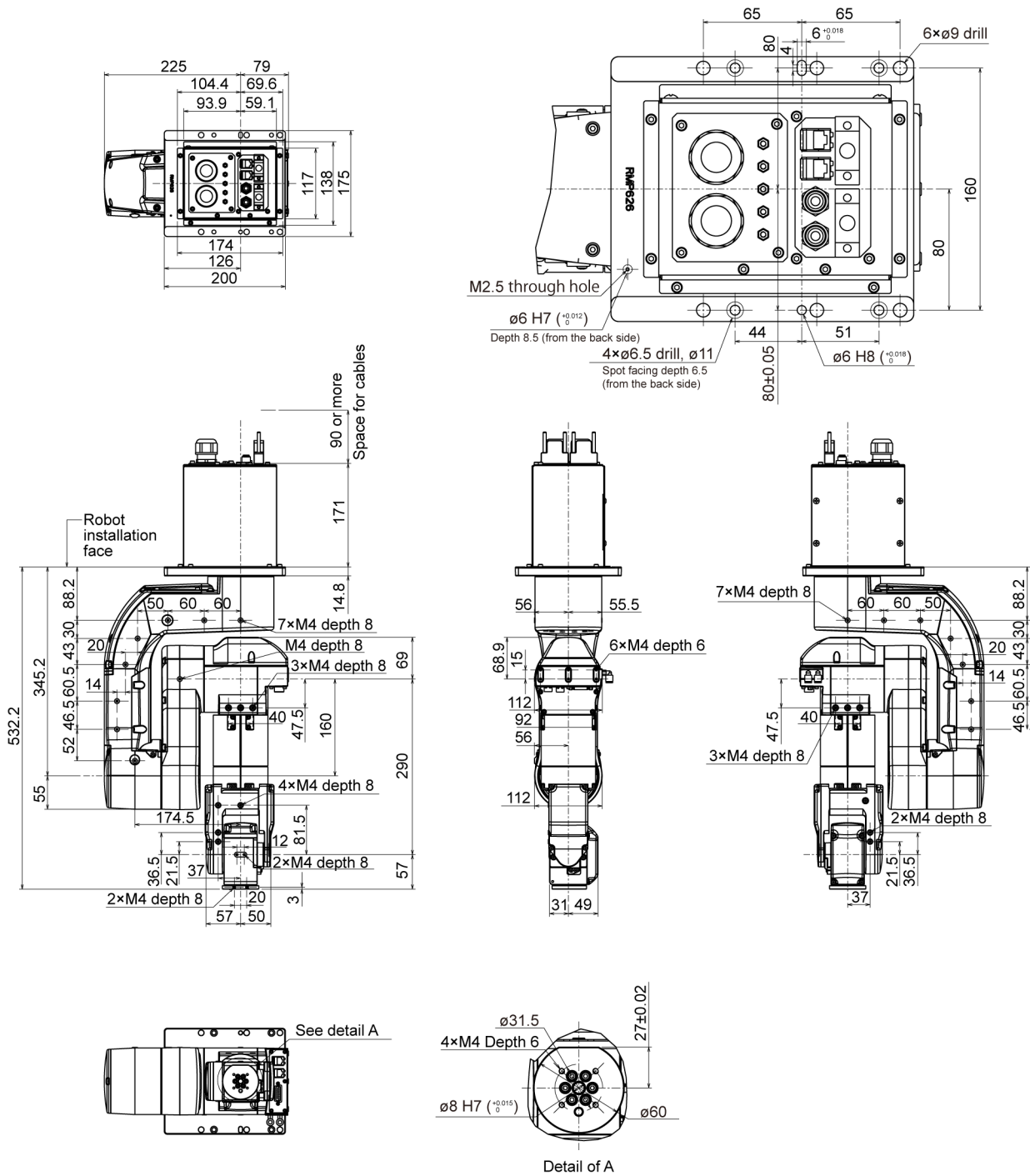

2.3.2 S/N: N201010001 or later

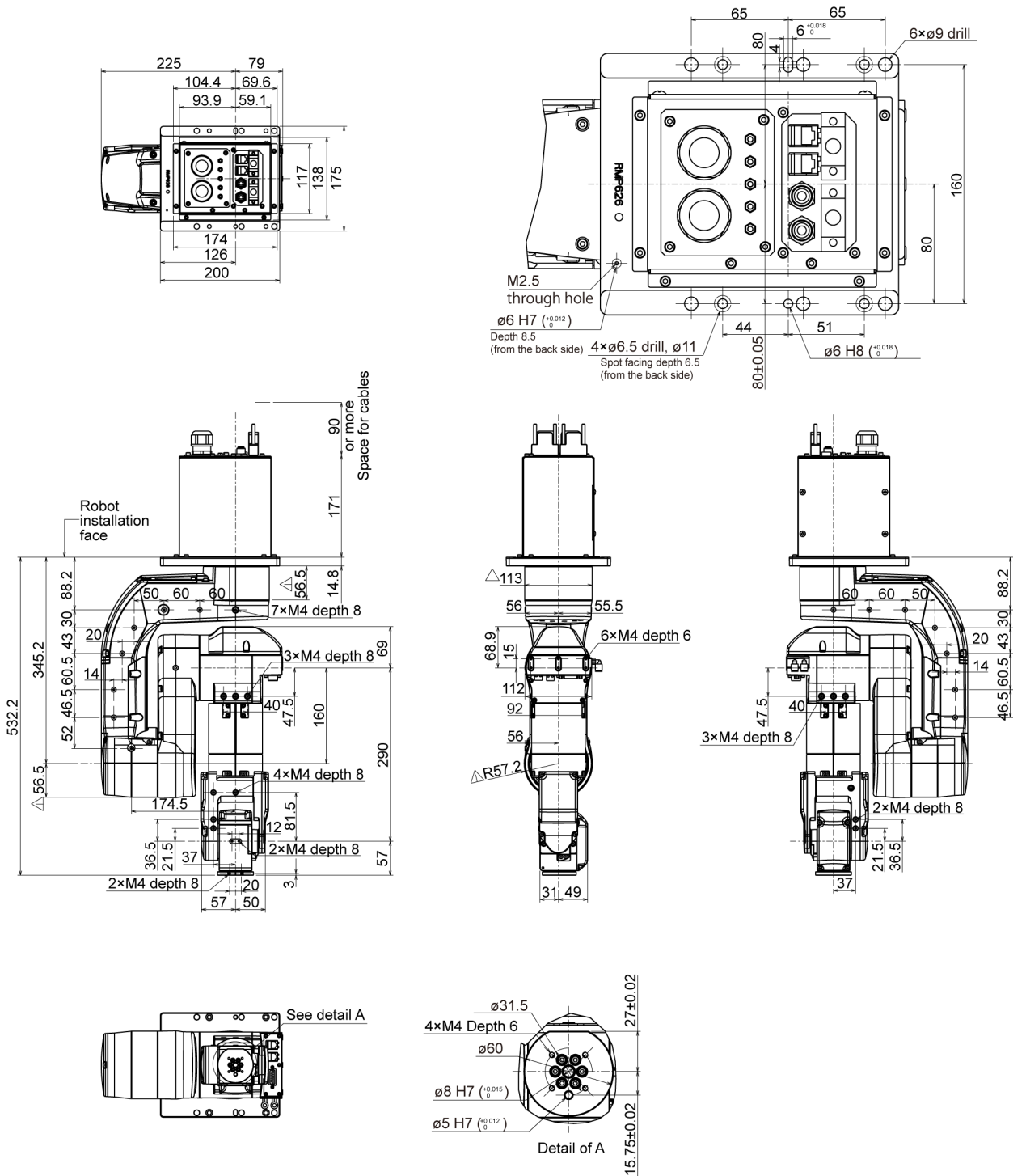

△: Difference from "2.4.1 S/N: N201000001~N201010000"

2.4 Standard Motion Range

[Unit: mm]

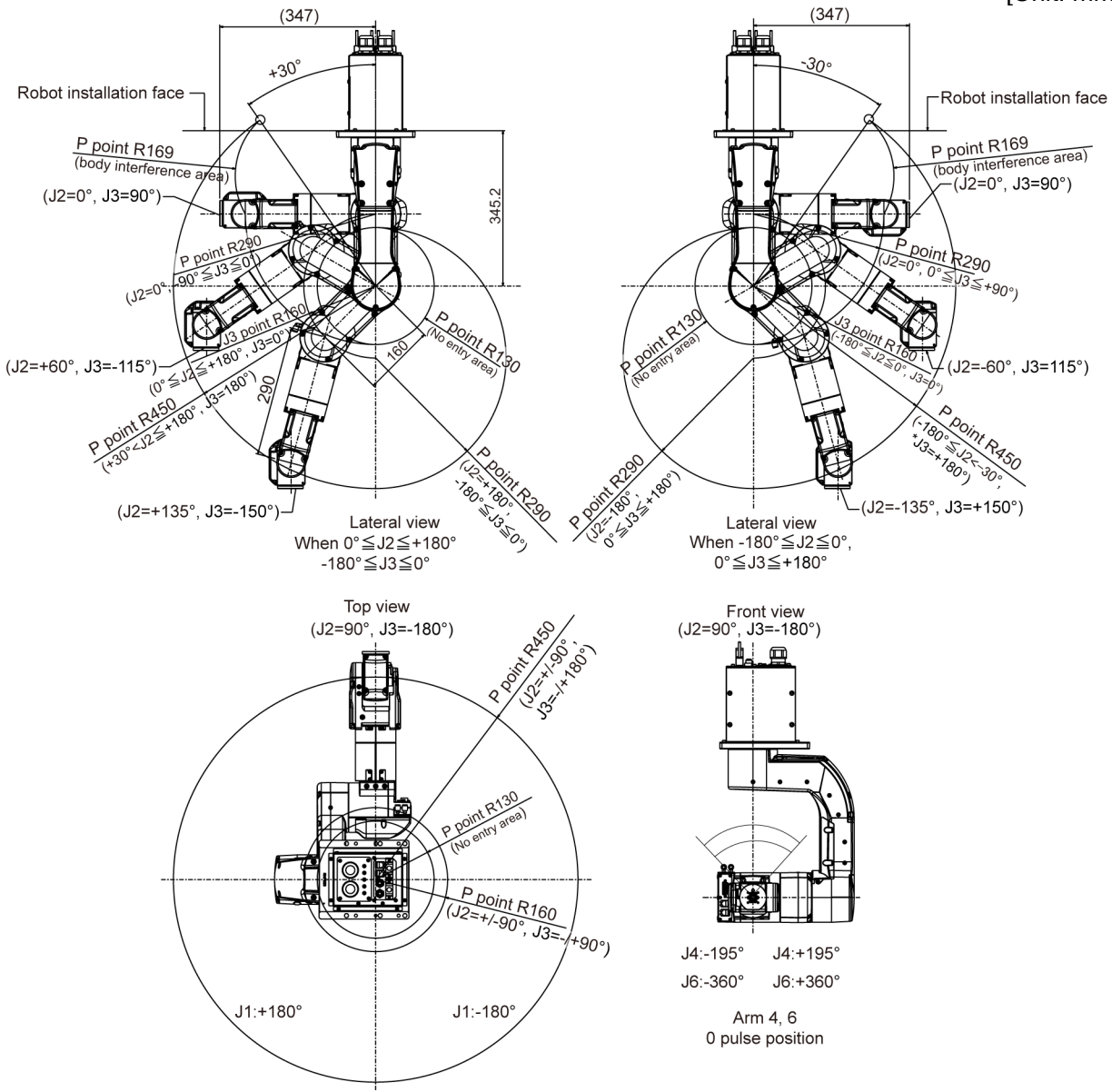

(°: degree)

* P point : Intersection of the rotation centers for Joint #4, #5, and #6

 CAUTION	<p>■ Pay attention to the arm pose of the basic arms (Arms #1, #2, and #3) when operating the Manipulator. Arm #5 moves keeping a constant angle regardless of the arm pose. Depending on the arm pose of the basic arms, the wrist may collide with the Manipulator. The collision may cause equipment damage to and/or malfunction of the Manipulator.</p>
---	--

2.5 Specifications

2.5.1 Specifications table

For the specifications of each model, refer to “*Appendix A: N2 Specifications*”.

2.5.2 Option

N2 series have the following options. For details, refer to “*6. Options*”.

Brake release unit

The option for moving the arms manually by turning OFF the Solenoid brakes.

For EU : Power supply voltage 200 V, short connector included

For US/JP : Power supply voltage 100 V, short connector included

Short connector for the brake release unit

When using the brake release unit with the N2 series Manipulator, it is necessary to connect the short connector to the M/C power cable, or connect the M/C power cable with the Controller. (The brake release unit can be used while the Controller is de-energized state.)

If you are using C3 or C4 series Manipulator and already have the brake release unit, you can use it by connecting the M/C cable with the Controller, or purchasing the short connector separately and connecting it to the M/C power cable.

Camera plate unit

The option for mounting the camera to the Manipulator.

Tool adapter (ISO flange)

The option for mounting the end effector whose dimensions are designed for the ISO flange to the N2 series Manipulators.

User wires

The option for using the internal wiring for the end effector drive.

Standard user connector kit: Standard D-sub 15-pin × 2

Wiring guide

The guide tool for wiring the user wires and pneumatic tubes.

Leave marginal length for the cables and tubes according to the operating specifications of your system.

Table Top mount bracket

The bracket for table top mounting.

It is also possible to install the Manipulator on the base table by making an installation hole like ceiling mounting.

Calibration plate

The option used for calibration.

It helps to perform calibration with higher accuracy than calibration using the origin position marks (0 pulse position) on the exterior of the Manipulator.

2.6 How to Set the Model

The Manipulator for your system has been set before shipment.



CAUTION

- When you need to change the setting of the Manipulator model, be sure to set the Manipulator model properly. Improper setting of the Manipulator model may result in abnormal or no operation of the Manipulator and/or cause safety problems.

NOTE



If the custom specifications number (MT***) or (X***) is described on the signature label (S/N label), the Manipulator has custom specifications. (A label with only the custom specifications number may be attached depending on shipment time.)

The custom specifications may require a different configuration procedure; check the custom specifications number and contact the supplier of your region when necessary.

The Manipulator model can be set from software.

Refer to the chapter *Robot Configuration* in the *Epson RC+ User's Guide*.

3. Environment and Installation

Design and installation of robot system shall be performed by personnel who has taken robot system training held by us and suppliers and should conform to all national and local codes.

3.1 Environmental Conditions

A suitable environment is essential for the robot system to function properly and safely. Be sure to install the robot system in an environment that meets the following conditions:

Item	Conditions
Ambient temperature* ¹	5 to 40 °C
Ambient relative humidity	20 to 80% (no condensation)
Fast transient burst noise	1 kV or less (Signal wire)
Electrostatic noise	4 kV or less
Altitude	1000 m or lower
Environment	<ul style="list-style-type: none"> - Install indoors - Keep away from direct sunlight - Keep away from dust, oily smoke, salinity, metal powder or other contaminants - Keep away from flammable or corrosive solvents and gases - Keep away from water - Keep away from shock or vibration - Keep away from sources of electric noise - Keep away from explosive area - Keep away from a large quantity of radiation

*1 The ambient temperature conditions are for the Manipulators only. For the Controller which the Manipulator is connected to, refer to the Controller manual.

When the product is used in a low temperature environment around the minimum temperature of the product specification, or when the product is suspended for a long time on holidays or at night, a collision detection error may occur due to the large resistance of the drive unit immediately after the start of operation. In such a case, it is recommended to warm up for about 10 minutes.



When using the Manipulators in inadequate environments that do not meet the above conditions, please contact the supplier of your region.

Special Environmental Conditions

The surface of the Manipulator has general oil resistance. However, if your requirements specify that the Manipulator must withstand certain kinds of oil, please contact the supplier of your region.

Rapid change in temperature and humidity can cause condensation inside the Manipulator. If your requirements specify that the Manipulator handles food, please contact the supplier of your region to check whether the Manipulator will damage the food or not.

The Manipulator cannot be used in corrosive environments where acid or alkaline is used. In a salty environment where the rust is likely to gather, the Manipulator is susceptible to rust.

 WARNING	<ul style="list-style-type: none"> ■ Use an earth leakage breaker on the AC power cable of the Controller to avoid the electric shock and circuit breakdown caused by short circuit. Prepare the earth leakage breaker that pertains the Controller you are using. For details, refer to the Controller manual.
--	--

 CAUTION	<ul style="list-style-type: none"> ■ When cleaning the Manipulator, do not rub it strongly with alcohol or benzene. It may lose luster on the coated face.
--	---

3.2 Unpacking, Transportation, and Relocation

Using a cart or similar equipment, transport the Manipulator in the same conditions as it was delivered. Observe the following when unpacking the Manipulator.

Unpacking, transportation, and relocation shall be performed by personnel who has taken robot system training held by us and suppliers and should conform to all national and local codes.

 WARNING	<ul style="list-style-type: none"> ■ Only authorized personnel should perform sling work and operate a crane or a forklift. When these operations are performed by unauthorized personnel, it is extremely hazardous and may result in serious bodily injury and/or severe equipment damage to the robot system. ■ Stabilize the Manipulator with your hands when hoisting it. Unstable hoisting is extremely hazardous and may result in serious bodily injury and/or severe equipment damage to the robot system as the fall of the Manipulator.
---	--

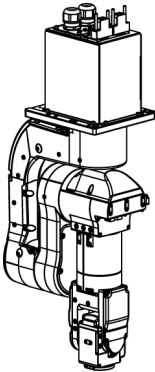
 CAUTION	<ul style="list-style-type: none"> ■ When removing the anchor bolts, support the Manipulator to prevent falling. Removing the anchor bolts without supporting the Manipulator may get hands, fingers, or feet caught as the Manipulator may fall. ■ To carry the Manipulator, be sure to have at least 2 people to hold the bottom of the base or the Arm by hand. When holding the base installation face by hand, be careful not to cause your hands and fingers caught. <div style="text-align: center;">  <p>Manipulator weight: 19 kg: 42 lbs.</p> </div> <ul style="list-style-type: none"> ■ Avoid excessive vibration or shock during Manipulator transporting. Excessive vibration or shock may cause equipment damage to and/or malfunction of the Manipulator.
--	---

Be sure to transport and store the robot system in environments that meet the following conditions:

Item	Conditions
Ambient temperature	0 to 45 °C
Ambient relative humidity	10 to 80 % (no condensation)

During unpacking and relocation, avoid applying external force to the arms and motors of the Manipulator.

When transporting the Manipulator for a long distance, secure it to the delivery equipment so that the Manipulator cannot fall. If necessary, pack the Manipulator in the same way as it was delivered.

When condensation occurs on the Manipulator during transport or storage, turn ON the power only after the condensation dries.

When using the Manipulator for the robot system again after long-term storage, perform a test run to verify that the Manipulator works properly. Then, operate the Manipulator thoroughly.

Relocating

Follow the procedures described below when relocating the Manipulator.

- (1) Turn ON the Controller.
- (2) Change the Manipulator posture so that it is easy to support when removing it.

Recommended posture: Joint #2 – 45°
Joint #3 – 45°

Epson RC+ Command
> Go AglToPls (0, -45, -45, 0, 0, 0)

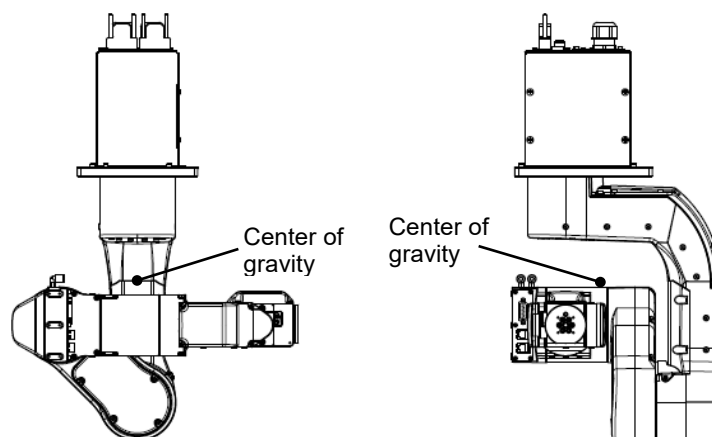

- (3) Turn OFF the power for all devices and unplug the power cable connector and signal cable connector from the Controller.

Do not unplug the M/C cable (power cable and signal cable) from the Manipulator.
(M/C cable 3 m: 2 kg)

- (4) Unscrew the anchor bolts. Then, remove the Manipulator from the base table.

- (5) Secure the Manipulator to the delivery equipment or have at least 2 people to carry the Manipulator.
- (6) After installing the Manipulator, turn ON the Controller.
- (7) Return the Manipulator to the basic orientation.

Epson RC+ Command
> Pulse 0, 0, 0, 0, 0, 0

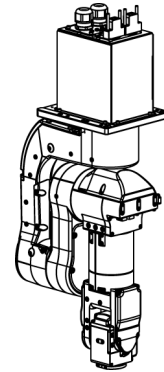

NOTE

The Joint #1 is not equipped with the brake. When installing the Manipulator, be careful not to rotate the Joint #1.

The cable may break when exceeding Max. motion range. Be careful when operating.

3.3 Mounting Dimensions

Mounting Area

Be sure to have the following space available in addition to the space for mounting the Manipulator, Controller, and peripheral equipment.

- Space for teaching points
- Space for maintenance and inspections (for installing jigs)
- Space for cables
- Space for mounting holes (only for V/P model)



When installing the cable, be sure to maintain sufficient distance from obstacles.
 For the minimum bend radius of the MC cable, refer to "Appendix A: N2 Specifications".
 In addition, leave enough space for other cables so that they are not bent forcibly.

[Unit: mm]

Mounting dimensions

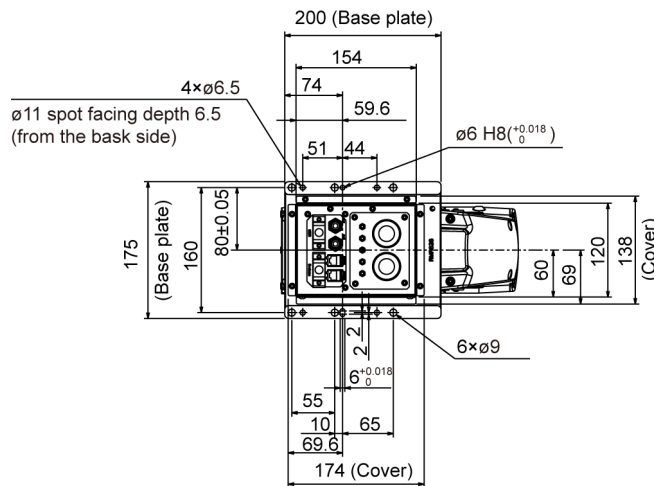

Motion range

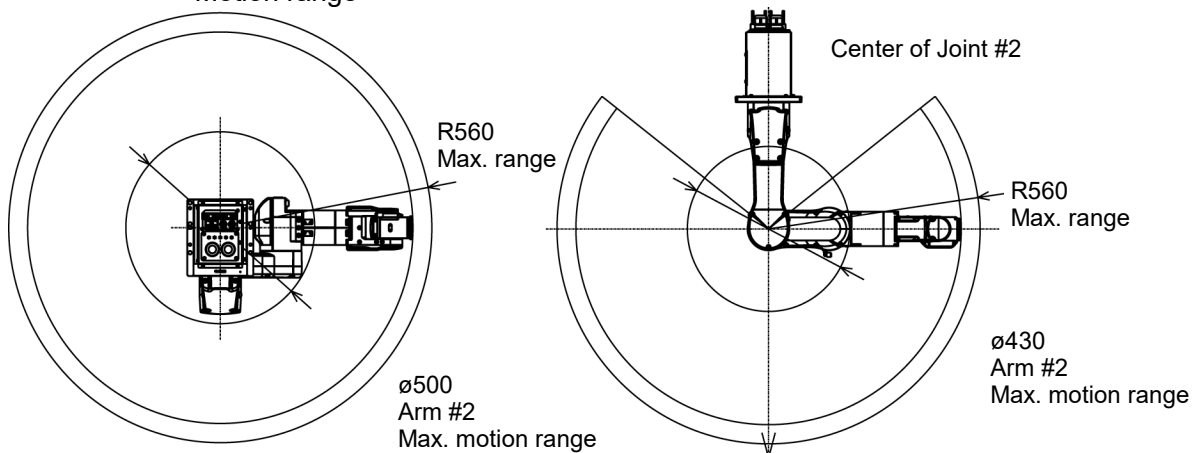

The maximum ranges in the above figure are the case when the end effector is 50 mm. If the end effector is longer than 50 mm, or the camera or the electromagnetic valve attached on the Arm is large, define the max motion ranges by considering the area where these tools may reach.

3.4 Installation

The installation shall be made by personnel who has taken robot system training held by us and suppliers and should conform to all national and local codes.

 WARNING	<ul style="list-style-type: none"> ■ To ensure safety, a safeguard must be installed for the robot system. For details on the safeguard, refer to the <i>Installation and Design Precautions</i> in the <i>Safety</i> chapter of the Epson RC+ User's Guide. ■ Install the Manipulator in a location with sufficient space so that a tool or a work piece does not touch a wall or a safeguard when the Manipulator extends its arm fully while holding a work piece. Installing the Manipulator at a location with insufficient space is extremely hazardous and may result in serious bodily injury and/or severe equipment damage to the robot system as a tool or a work piece may collide with a wall or a safeguard. ■ Anchor the Manipulator before turning ON the power to or operating the Manipulator. Turning ON the power to or operating the Manipulator that is not anchored is extremely hazardous and may result in serious bodily injury and/or severe equipment damage to the robot system as the Manipulator may fall down. ■ Before installing and operating the Manipulator, make sure that all parts of the Manipulator are in place and have no external defects. Missing or defective parts may cause improper operation of the Manipulator. Improper operation of the Manipulator is extremely hazardous and may result in serious bodily injury and/or severe equipment damage to the robot system.
--	---

 CAUTION	<ul style="list-style-type: none"> ■ The Manipulator must be installed to avoid interference with buildings, structures, utilities, other machines and equipment that may create a trapping hazard or pinch points. ■ Oscillation (resonance) may occur during operation depending on rigidity of the installation table. If the oscillation occurs, improve rigidity of the table or change the speed or acceleration and deceleration settings.
--	---

Mounting bolt

For the dimensions, refer to “3.3 Mounting Dimensions”.

There are four threaded holes for the Manipulator base.

Use M6 mounting bolts conforming to the strength of ISO898-1 property class 10.9 or 12.9.

Tightening torque: 13 N·m (133 kgf·cm)

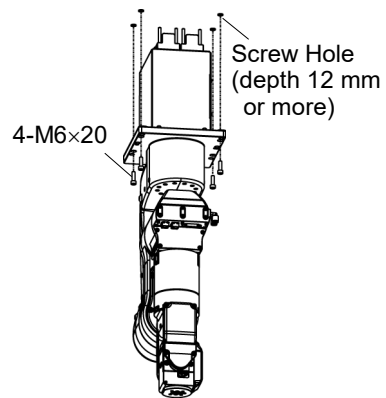

Example of working space (recommended)

The base and the base cover need to be removed when performing maintenance and inspection. Leave ample space around the base for maintenance (such as battery replacement) and inspection.

Recommended space

Above the base: About 400 mm from the base plate

Side of the base: About 200 mm from the base cover and the base

NOTE  When the working space is not left, the Manipulator needs to be removed from the working table for maintenance and inspection.

Example: When replacing the battery

Removing the base

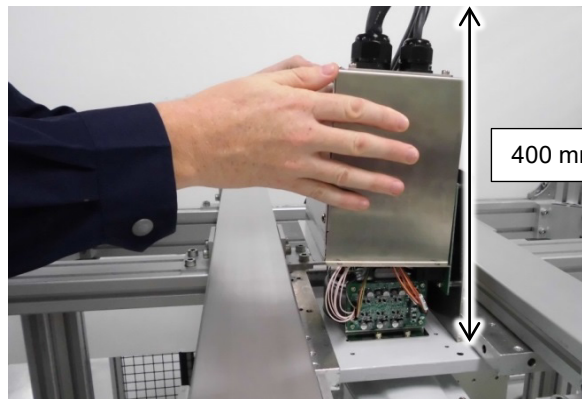

Leave about 400 mm above the base plate. (in case of ceiling mount Manipulator)

Removing the base cover

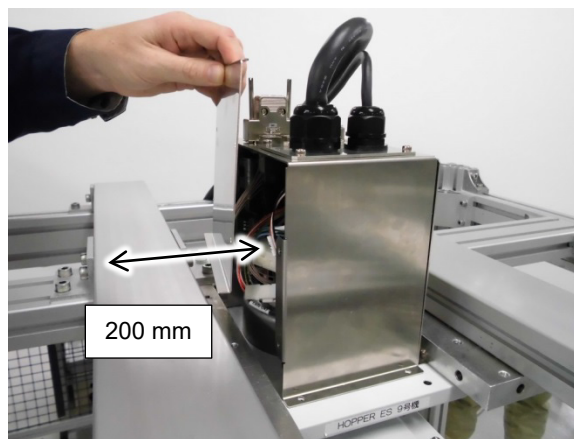

Leave about 200 mm from the base cover.

Removal and installation procedures of the base cover are described in the following section.

N series Maintenance Manual

N2 Manipulator - Base Cover

3.5 Base Table

A base table for anchoring the Manipulator is not supplied. Please make or obtain the base table for your Manipulator. The shape and size of the base table differ depending on the intended use of the robot system. The following is the basic requirements of Manipulator table for your reference.

The base table must not only be able to bear the weight of the Manipulator but also be able to withstand the dynamic movement of the Manipulator when it operates at maximum acceleration/deceleration. Ensure that there is enough strength on the base table by attaching reinforcing materials such as crossbeams.

The torque and reaction force produced by the movement of the Manipulator are as follows:

Model number	N2-A450S*
Model name	N2
Max. Horizontal rotating torque (N·m)	200
Max. Horizontal reaction force (N)	300
Max. Vertical rotating torque (N·m)	300
Max. Vertical rotating torque (N)	1600

 CAUTION	<ul style="list-style-type: none"> ■ If the vibration of the base table is large, reduce the acceleration/deceleration or increase the rigidity of the base table to reduce the vibration. Continued use in a state of large vibration may cause loosening of fastening parts or excessive load on mechanical parts, which may shorten the lifespan.
---	---

The plate for the Manipulator mounting face should be 20 mm thick or more and made of steel to reduce vibration. The surface roughness of the steel plate should be 25 μm or less.

The base table must be secured on the floor to prevent it from moving.

The Manipulator installation surface should have a flatness of 0.5 mm or less and an inclination of 0.5 ° or less. If the flatness of the installation surface is improper, the base may be damaged or the robot may not fully show its performance.

When using a leveler to adjust the height of the base table, use a screw with M16 diameter or more.

Connector

If you are passing cables through the holes on the base table, see the figures below.

[unit : mm]

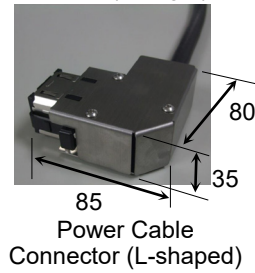
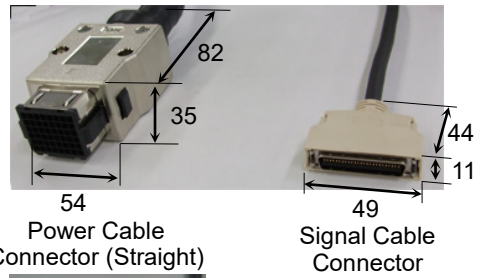
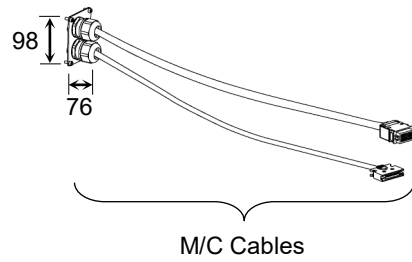

Do not remove the M/C cables from the Manipulator.



For environmental conditions regarding space when placing the Controller on the base table, refer to the Controller manual.

 WARNING	<ul style="list-style-type: none"> ■ To ensure safety, a safeguard must be installed for the robot system. For details on the safeguard, refer to the <i>Epson RC+ User's Guide</i>.
-------------	---

Base Table – Design Example

The following is an example for designing the base table of the N2 Manipulator. During the operation of N2 in the maximum acceleration/deceleration speed, the base table must be steady enough to prevent the vibration from transmitting to N2.

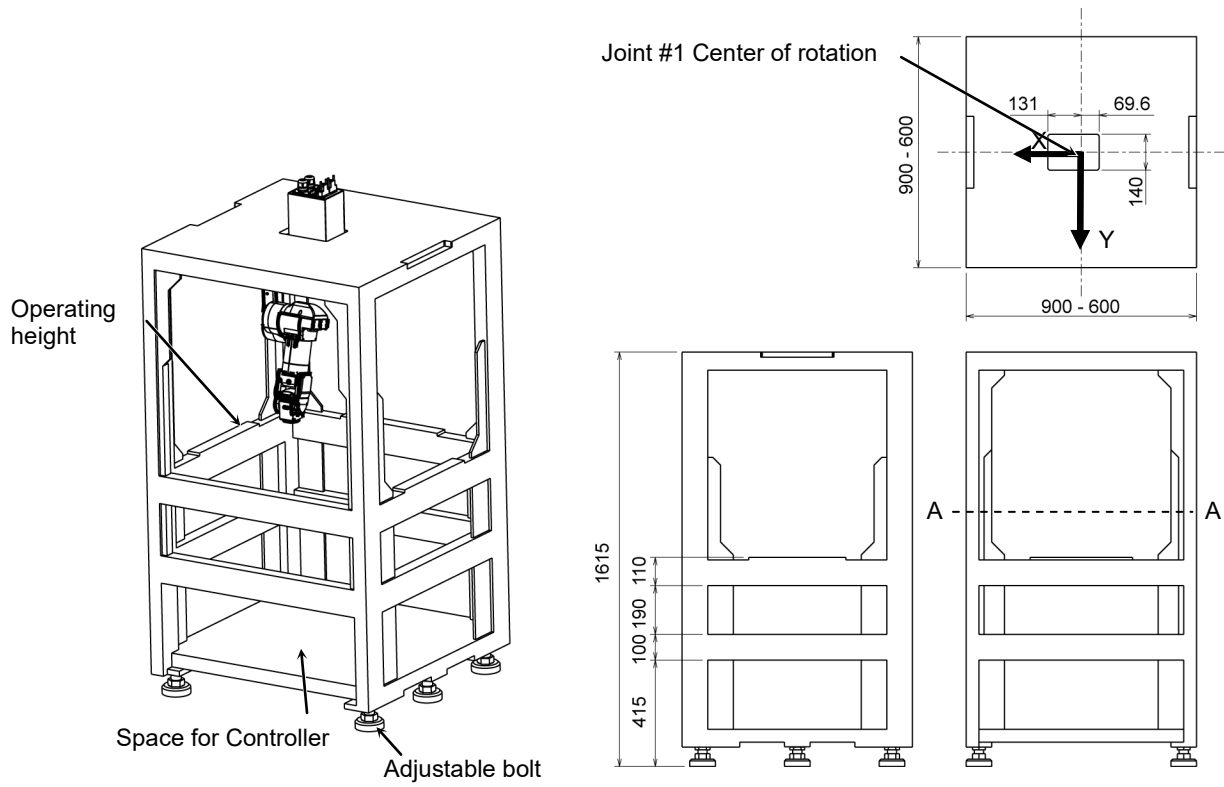

- Wight of table : approx. 300 kg (□900) to approx. 250 kg (□600)
- Material for the flame : Iron pipe: □ 100 × 50 mm
Thickness: 3.2 mm (□900) to 6 mm (□600)
- Adjustable bolt : M36
- Geometrical moment of inertia : $I_x = 1.2 \times 10^9 \text{ mm}^4$
 $I_y = 1.2 \times 10^9 \text{ mm}^4$

- Set low aspect ratio of the base table height and width.
- Put center of gravity lower position by installing the Controller on the bottom of the base table.
- Reinforce the open part with joist or similar material to minimize the part.
- The condition depends on the table height, width, the position of joist, and the center of gravity.

3.6 Connecting the Cables



WARNING

- Before performing any replacement procedure, turn OFF the Controller and related equipment, and then disconnect the power plug from the power source. Performing any replacement procedure with the power ON is extremely hazardous and may result in electric shock and/or malfunction of the robot system.
- Be sure to connect the AC power cable to a power receptacle. DO NOT connect it directly to a factory power source. To shut off power to the robot system, disconnect the power plug from the power source. Performing any work while connecting the AC power cable to a factory power source is extremely hazardous and may result in electric shock and/or malfunction of the robot system.
- Be sure to connect the cables properly. Do not allow unnecessary strain on the cables. (Do not put heavy objects on the cables. Do not bend or pull the cables forcibly.) The unnecessary strain on the cables may result in damage to the cables, disconnection, and/or contact failure. Damaged cables, disconnection, or contact failure is extremely hazardous and may result in electric shock and/or improper function of the robot system.
- Before wiring, turn OFF the Controller and related equipment, and then pull up a warning sign (e.g. DO NOT TURN ON THE POWER.). Wiring with the power ON is extremely hazardous and may result in electric shock and/or malfunction of the robot system.
- When connecting / replacing the brake release unit or the external short connector, turn OFF the power to the Controller and the brake release unit. Inserting and removing the connector while the power is ON may result in electrical shock.



CAUTION

- When connecting the Manipulator and the Controller, make sure that the serial numbers on each equipment match. Improper connection between the Manipulator and Controller may not only cause improper function of the robot system but also safety problems. The connection method varies with the Controller used. For details on the connection, refer to the Controller manual.
- Only authorized or certified personnel should be allowed to perform wiring. Wiring by unauthorized or uncertified personnel may result in bodily injury and/or malfunction of the robot system.
- If the Manipulator is operated without connecting the brake release unit or the external short connector, the brakes cannot be released and it may cause damage on them. After using the brake release unit, be sure to connect the external short connector to the Manipulator, or check connection of the connector for the brake release unit.

M/C Cable Connection method

Connect the power connector and the signal connector of the M/C cables to the Controller.

 WARNING	<ul style="list-style-type: none"> When using metal ducts, metallic conduits, or distributing racks for cable, ground in accordance with national and local electric equipment technical standards. Grounding that does not meet the standards may result in electric shock and/or malfunction of the robot system.
--	--

3.7 User Wires and Pneumatic Tubes

 CAUTION	<ul style="list-style-type: none"> Only authorized or certified personnel should be allowed to perform wiring. Wiring by unauthorized or uncertified personnel may result in bodily injury and/or malfunction of the robot system.
--	---

User electrical wires and pneumatic tubes are contained in the cable unit.

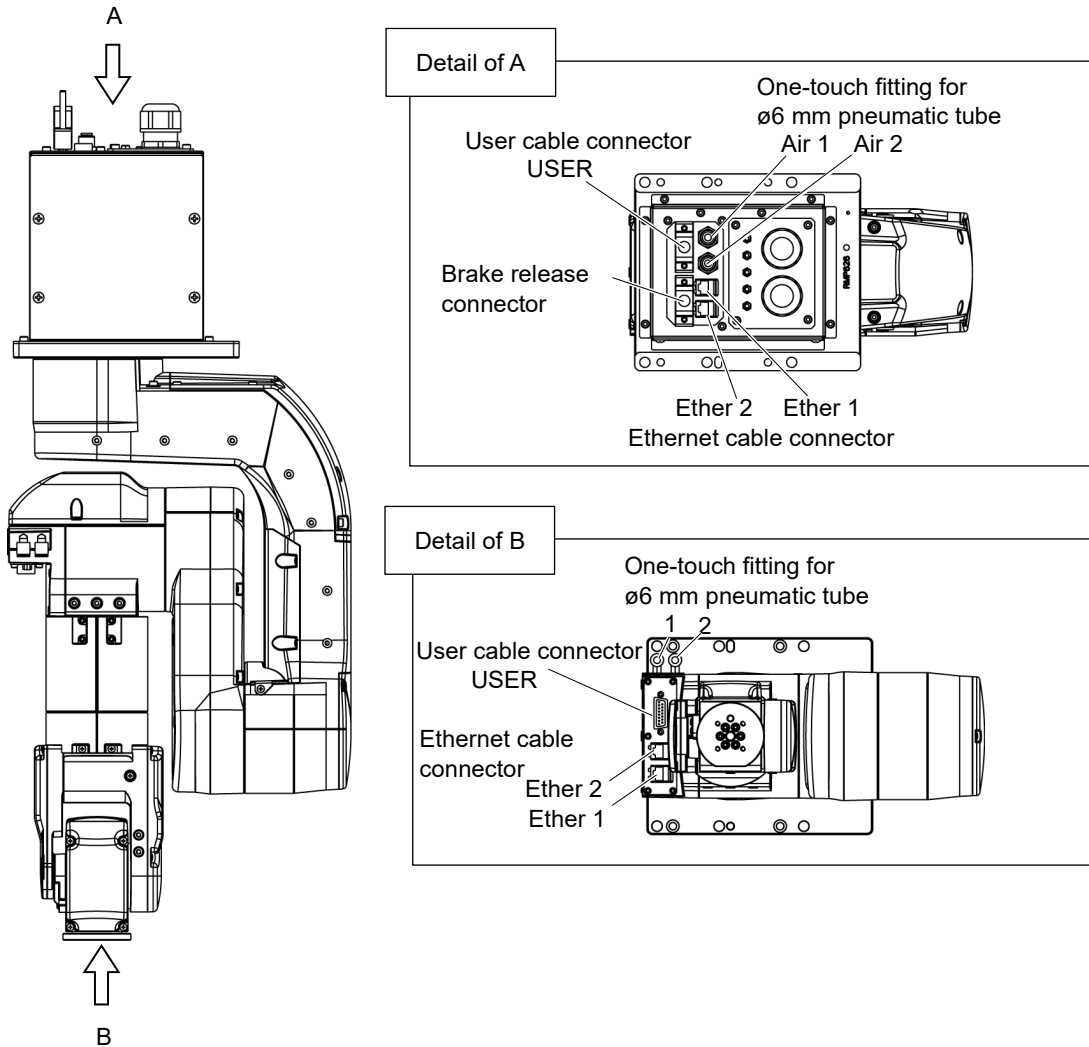

NOTE  The user cable connector and the brake release connector have the same shape. Be careful not to connect the wrong connector.

NOTE  The Ethernet cable connectors Ether 1 and Ether 2 have the same shape. Be careful not to connect the wrong connector.

Electrical wires

Specifications of the user wires D-sub 15-pin

Rated Voltage	Allowable Current	Wires	Nominal Sectional Area	Note
AC/DC30 V	1 A	15	0.106 mm ²	Shielded

Pins with the same number, indicated on the connectors on both ends of the cables, are connected.

Attached connector for the user wires

		Maker	Standard
15 pin	Connector	JAE	DA-15PF-N (Solder type)
	Clamp Hood	HRS	HDA-CTH(4-40)(10) (Connector setscrew: #4-40 UNC)

Two parts are attached for each.

8 pin (RJ45) Cat.5e or equivalent

The commercially available Ethernet cables can be used.

For details, refer to “6. Option”.

Pneumatic tubes

Max. Usable Pneumatic Pressure	Pneumatic Tubes	Outer Diameter × Inner Diameter
0.59 MPa (6 kgf/cm ² : 86 psi)	2	ø6 mm × ø4 mm

3.8 Checking the Basic Orientation

At the time of shipment, the basic orientation of the Manipulator shown below is set as the origin position.

After installing the Manipulator and setup the operating environment, move the Manipulator to the origin position and check if it moves to the basic position properly.

How to return to the origin position

- (1) Turn ON the Controller.
- (2) Turn ON the Manipulator motors.

Epson RC+ Command
> Motor On

- (3) Move the joints to the origin position.

Epson RC+ Command
> Pulse 0, 0, 0, 0, 0, 0

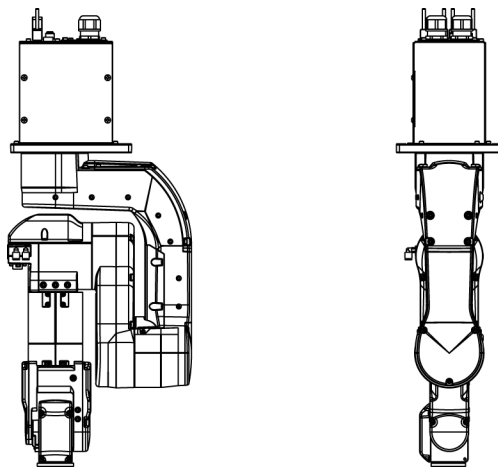

Basic Orientation

Calibration

After parts (motors, reduction gear units, belts, etc.) have been replaced due to malfunction or any other reason, a gap occurs between the origin positions.

The process to compensate the position gap is called “Calibration”.

If the gap still exists and the Manipulator cannot be in the basic orientation after the calibration, please contact the supplier of your region.

4. End Effectors

4.1 Attaching an End Effector

Create an end effector for your Manipulator. For details of attaching an end effector, refer to “*Hand Function Manual*”.

Flange dimensions of the wrist attached to the end of Arm #6 is as below.

 CAUTION	<ul style="list-style-type: none"> ■ If you use an end effector equipped with a gripper or chuck, connect wires and/or pneumatic tubes properly so that the gripper does not release the work piece when the power to the robot system is turned OFF. Improper connection of the wires and/or pneumatic tubes may damage the robot system and/or work piece as the work piece is released when the Emergency Stop switch is pressed. I/O outputs are configured at the factory so that they are automatically shut off (0) by power disconnection, the Emergency Stop switch, or the safety features of the robot system. However, the I/O set in the hand function does not turn off (0) when the Reset command is executed or in emergency stop.
---	---

Wrist Flange

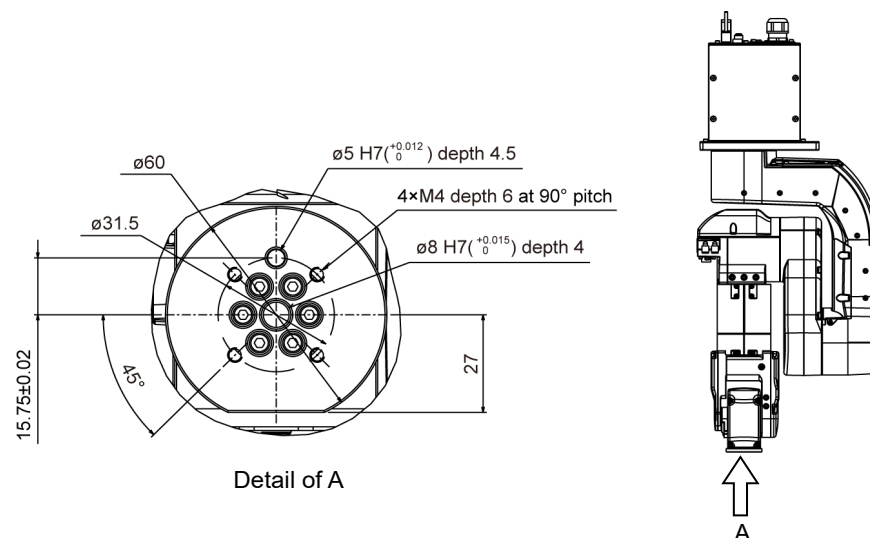

Arm #6

Attach an end effector to the end of the Arm #6 using the M4 bolts.

Screw depth of Arm #6 screw: 6 mm

Layouts

When you operate the Manipulator with an end effector, the end effector may interfere with the Manipulator body depending on the outer diameter of the end effector, the size of the work piece, or the position of the arms. When designing your system layout, pay close attention to the interference area of the end effector.

Compatibility with ISO flange:

For installing the end effector whose mounting dimensions are designed for the ISO flange, the optional tool adapter (ISO flange) is available.

For details, refer to “6. Options”.

4.2 Attaching Camera and Air Valves

The decks are equipped to the Arms #3 and #5 for easy installation of the air valves.

To mount the camera, the camera plate unit is necessary.

The optional Camera Plate Unit is available. For details, refer to “6. Options”.

N2-A450S*

[Unit: mm]

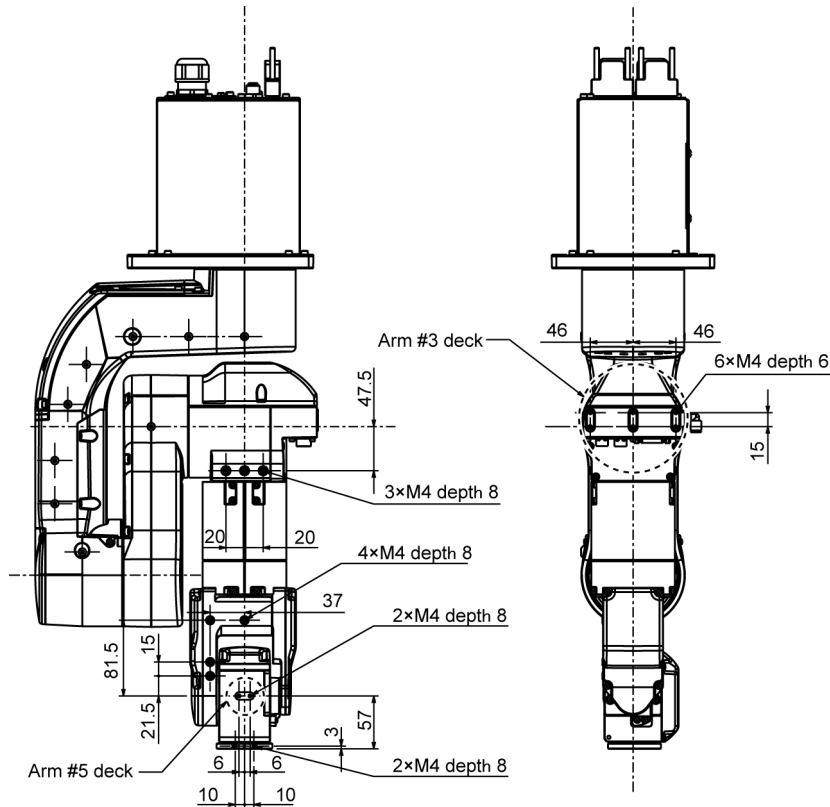

4.3 WEIGHT and INERTIA Settings

The WEIGHT and INERTIA (inertia moment and eccentricity) commands are for setting the load parameters of the Manipulator. These settings optimize the Manipulator motion.

WEIGHT Setting

The WEIGHT command is for setting the load weight. The more the load weight increases, the more the speed and acceleration/deceleration are reduced.

INERTIA Setting

The INERTIA command is for setting the inertia moment and the eccentricity of the load. The more the inertia moment increases, the more the acceleration and deceleration of the Arm #6 are reduced. The more the eccentricity increases, the more the acceleration and deceleration for the Manipulator movement are reduced.

To ensure optimum Manipulator performance, make sure that the load (weight of the end effector and work piece) and inertia moment of the load are within the maximum rating for the Manipulator, and that Arm #6 does not become eccentric.

If the load or the inertia moment exceeds the ratings or if the load becomes eccentric, follow the steps in “4.3.1 WEIGHT Setting” and “4.3.2 INERTIA Setting”, to set parameters.

Setting parameters makes the operation of the Manipulator optimal, reduces vibration to shorten the operating time, and improves the capacity for larger loads. In addition, it reduces persistent vibration produced when the inertia moment of the end effector and work piece is bigger.

The allowable load for N2 series Manipulators is 2.5 kg at the maximum.

Due to the limitations of the moment and inertia moment shown in the table below, the load (end effector weight + work piece weight) should also meet these conditions.

Allowable Load

Joint	Allowable Moment	GD ² /4 Allowable Moment of Inertia
#4	5.4 N·m (0.55 kgf·m)	0.2 kg·m ²
#5	5.4 N·m (0.55 kgf·m)	0.2 kg·m ²
#6	2.4 N·m (0.24 kgf·m)	0.08 kg·m ²

Moment

The moment indicates amount of torque applied on the joint in order to support the gravity on the load (end effector + work piece).

The moment increases as weight of the load and amount of eccentricity increase. As this also increases the load applied on the joint, make sure to keep the moment within the allowable value.

Inertia moment

The inertia moment indicates how difficult the load (end effector + work piece) to rotate when the Manipulator joint starts to rotate (amount of inertia). The inertia moment increases as weight of the load and amount of eccentricity increase. As this also increase the load applied on the joint, make sure to keep the inertia moment within the allowable value.

The moment M (Nm) and inertia moment I (kgm^2) when the volume of the load (end effector + work piece) is small can be obtained by the following formula.

$$M (\text{N}\cdot\text{m}) = m(\text{kg}) \times L (\text{m}) \times g (\text{m}/\text{s}^2)$$

$$I (\text{kgm}^2) = m(\text{kg}) \times L^2 (\text{m}^2)$$

m : Weight of load (kg)

L : Eccentric quantity of load (m)

g : Gravitational acceleration (m/s^2)

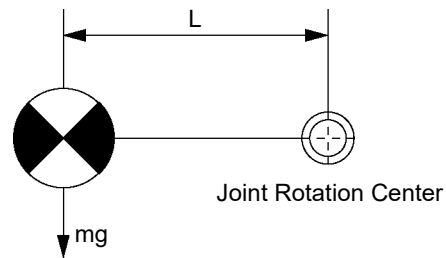

Design the end effector so that the moment M and the inertia moment I do not exceed the allowable load.

The eccentric quantity of load L should satisfy the following:

Less than 207 mm from the Arm #5 rotation center (150 mm or less from the flange)

Less than 150 mm from the Arm #6 rotation center

Example: When the load is 2.5 kg and the center of gravity is 100 mm from the flange:

$$m=2.5\text{kg}, L=100+57=157\text{mm}=0.157\text{m}$$

The moment M and the inertia moment are below the allowable load as follows:

$$\text{Moment } M : 2.5 \text{ kg} \times 0.157\text{m} \times 9.8 \text{ m}/\text{s}^2 = 3.85\text{Nm} < 5.4\text{Nm}$$

$$\text{Inertia moment } I : 2.5 \text{ kg} \times (0.157 \text{ m})^2 = 0.062 \text{ kgm}^2 < 0.2 \text{ kgm}^2$$

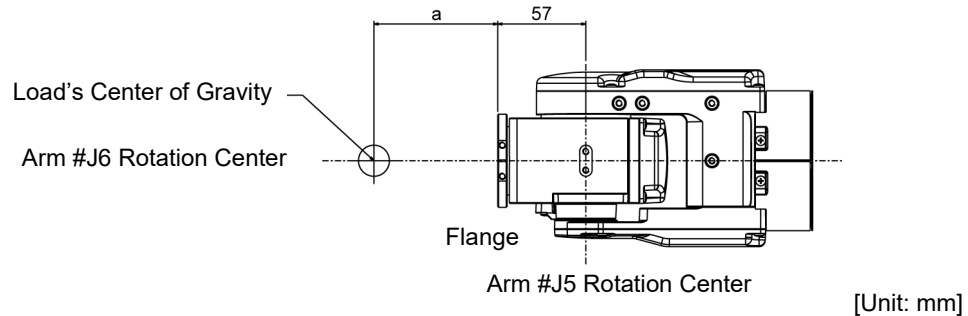

4.3.1 WEIGHT setting



- Set the total weight of the end effector and the work piece smaller than the maximum payload.

The N2 series Manipulators can operate without limitations on the condition unless and until the load exceeds this maximum payload. Always set the Weight parameters of the WEIGHT command according to the load. Setting a value that is smaller than the actual load may cause errors, excessive shock, insufficient function of the Manipulator, and/or shorten the life cycle of parts/mechanisms.

The acceptable weight capacity (end effector and work piece) for N2 series Manipulators is as follows:

Rated	Maximum
1 kg	2.5 kg

Change the setting of the Weight parameter according to the load.

After changing the Weight parameter setting, the maximum acceleration/deceleration and speed of the robot system corresponding to the load is set automatically.

Setting method of Weight parameters

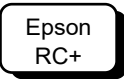

Select [Tools]-[Robot Manager]-[Weight] panel and set the value in [Weight:]. You may also execute the Weight command from [Command Window].

Load on the Manipulator

Mounting location of the load

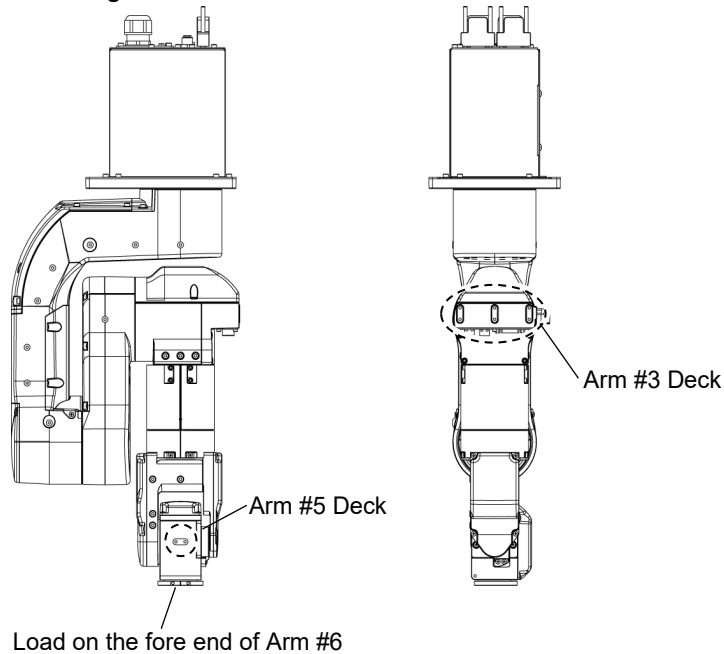

Details of the deck

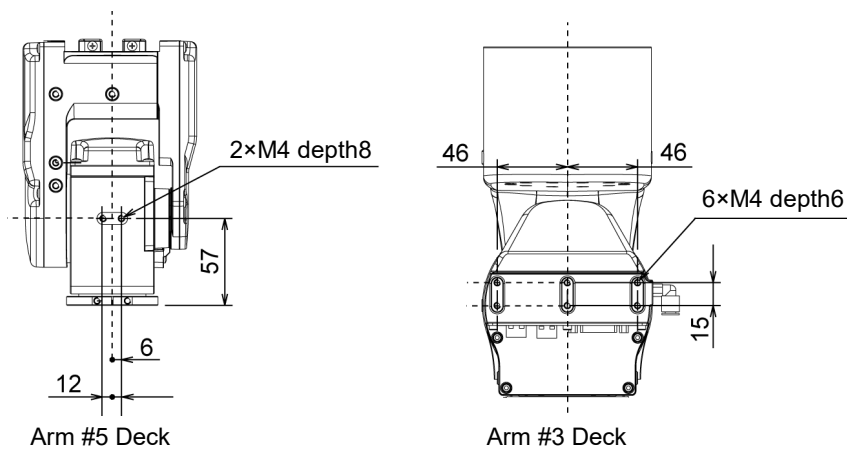

[Unit: mm]

When you attach the equipment to the decks on the upper arm, convert its weight into equivalent weight assuming that the equipment is attached to the end of the Arm #6. Then, this equivalent weight added to the load will be a Weight parameter.

Calculate the Weight parameter by using the formula below and enter the value.

Weight Parameter Formula

Weight parameter = $M_w + W_a + W_b$

M_w : Load on the fore end of Arm #6 (kg)
 W_a : Equivalent weight of the Arm #3 deck (kg)
 W_b : Equivalent weight of the Arm #5 deck (kg)

$W_a = M_a (L_a)^2 / (L)^2$
 $W_b = M_b (L_b)^2 / (L)^2$

M_a : Weight of the air valve on the Arm #3 deck
 M_b : Weight of the camera on the Arm #5 deck
 L : Length of the upper arm (mm)
 L_a : Distance between the Joint #3 and the center of gravity of the air valve on the Arm #3 deck (mm)
 L_b : Distance between the Joint #3 and the center of gravity of the camera on the Arm #5 deck (mm)

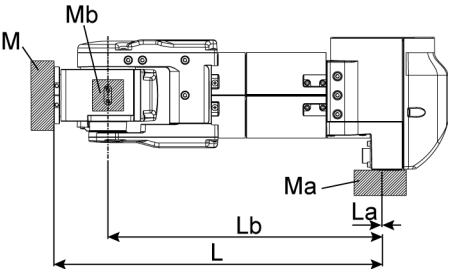

<Example> The fore end of the Arm #6 is 347 mm (L) away from the Joint #3 of N2-A450**.

Load on the fore-end of Arm #6 is 1.0 kg (M_w).

Load on the Arm #3 deck is 0.8 kg (M_a).

The deck is 0 mm (L_a) away from Joint #3.

Load on the Arm #5 deck is 0.5 kg (M_b).

The deck is 290 mm (L_b) away from the Joint #3.

$$W_a = 0.8 \times 0^2 / 347^2 = 0$$

$$W_b = 0.5 \times 290^2 / 347^2 = 0.35 \rightarrow 0.4 \text{ (round up)}$$

$$M_w + W_a + W_b = 1.0 + 0 + 0.4 = 1.4$$

Enter “1.4” for the Weight parameter.

Automatic speed setting by Weight parameter

The percentages in the graphs are based on the speed at rated weight (1 kg) as 100%.

N2-A450SR

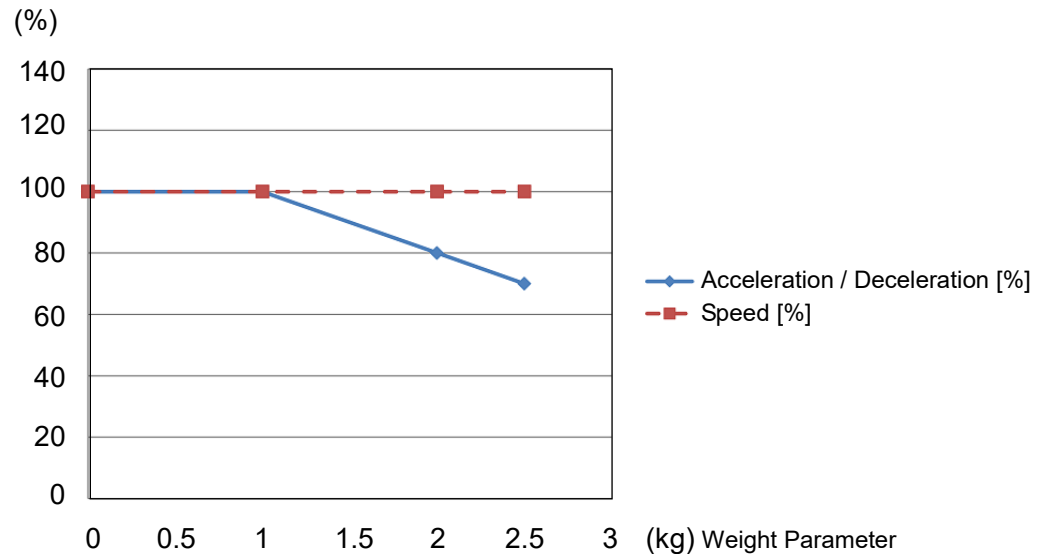

4.3.2 INERTIA setting

Inertia Moment and the INERTIA Setting

The inertia moment is defined as “the ratio of the torque applied to a rigid body and its resistance to motion”. This value is typically referred to as “the moment of inertia”, “inertia”, or “GD²”. When the Manipulator operates with objects such as an end effector attached to the Arm #6, the moment of inertia of load must be considered.



CAUTION

- The inertia moment of the load (weight of the end effector and work piece) must be 0.08 kg·m² or less. The N2 series Manipulators are not designed to work with inertia moment exceeding 0.08 kg·m². Always set the inertia moment (INERTIA) parameter according to the inertia moment. Setting a value that is smaller than the actual inertia moment may cause errors, excessive shock, insufficient function of the Manipulator, and/or shorten the life of parts/mechanisms.

The acceptable inertia moment of load for N2 series Manipulators is 0.005 kg·m² nominal rating and 0.08 kg·m² maximum. Change the setting of the inertia moment according to the inertia moment of the load using the INERTIA command. After the setting has been changed, the maximum acceleration/deceleration speed of Arm #6 responding to “inertia moment” is set automatically.

Inertia moment of load on Arm #6

The inertia moment of the load (weight of the end effector and work piece) on the Arm #6 can be set by the “inertia moment (INERTIA)” parameter of the INERTIA command.

Select [Tools]-[Robot Manager]-[Inertia] panel and enter the value in [Load inertia:]. You may also execute the Inertia command from [Command Window].

Eccentric Quantity and the INERTIA Setting



- The eccentric quantity of the load (weight of the end effector and work piece) must be 150 mm or less. The N2 series Manipulators are not designed to work with eccentric quantity exceeding 150 mm. Always set the eccentric quantity parameter according to the eccentric quantity. Setting a value that is smaller than the actual eccentric quantity may cause errors, excessive shock, insufficient function of the Manipulator, and/or shorten the life cycle of parts/mechanisms.

The acceptable eccentric quantity of the load for N2 series Manipulators is 30 mm at nominal rating and 150 mm at maximum. When the eccentric quantity of the load exceeds the rating, change the setting of eccentric quantity parameter using the INERTIA command. After changing the setting, the maximum acceleration/deceleration speed of Manipulator corresponding to “eccentric quantity” is set automatically.

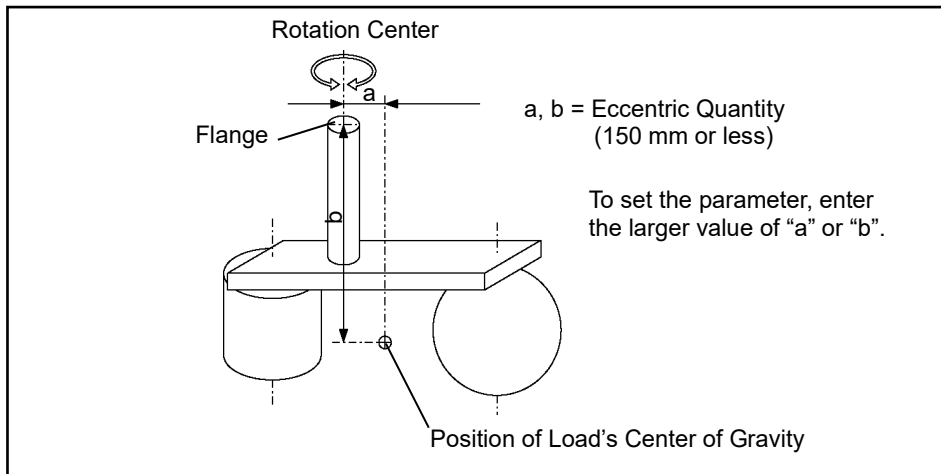

Eccentric Quantity

Eccentric quantity of load on Arm #6

The eccentric quantity of the load (weight of the end effector and work piece) on the Arm #6 can be set by the “eccentric quantity” parameter of the INERTIA command. Enter the larger value of either “a” or “b” in the figure above to [Eccentricity].

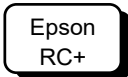

Select [Tools]–[Robot Manager]–[Inertia] panel and enter the value into [Eccentricity:]. You may also execute the Inertia command from [Command Window].

Automatic acceleration/deceleration setting by INERTIA (eccentric quantity)

Automatic setting by inertia moment setting

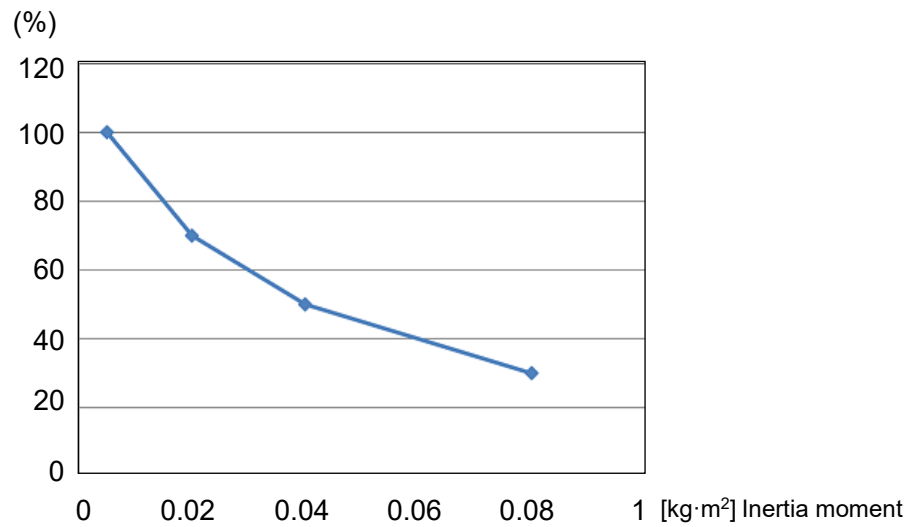

* The percentage in the graph is based on the acceleration / deceleration at rated eccentricity (0.005 kg·m²) as 100%.

Automatic setting by eccentricity setting

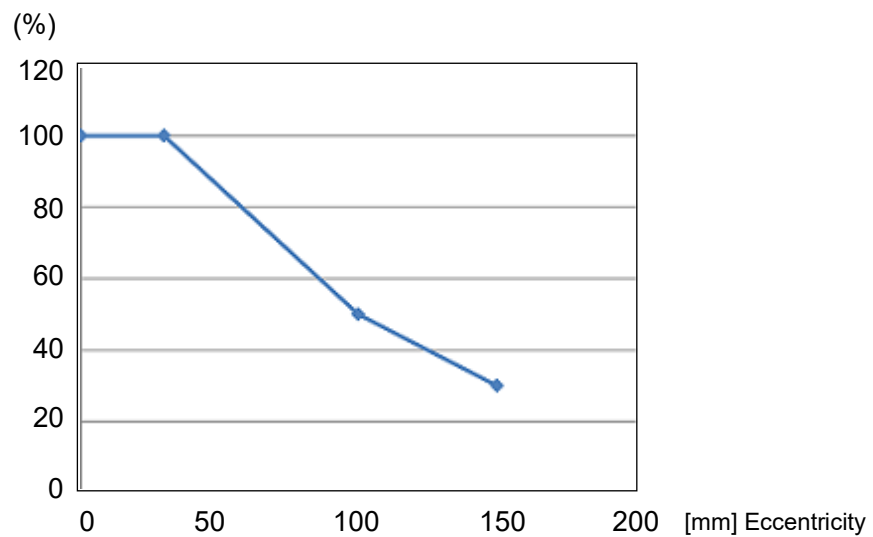

* The percentage in the graph is based on the acceleration / deceleration at rated eccentricity (30 mm) as 100%.

Calculating the Inertia Moment

Refer to the following example formulas to calculate the inertia moment of the load (end effector with work piece).

The inertia moment of the entire load is calculated by the sum of (a), (b), and (c).

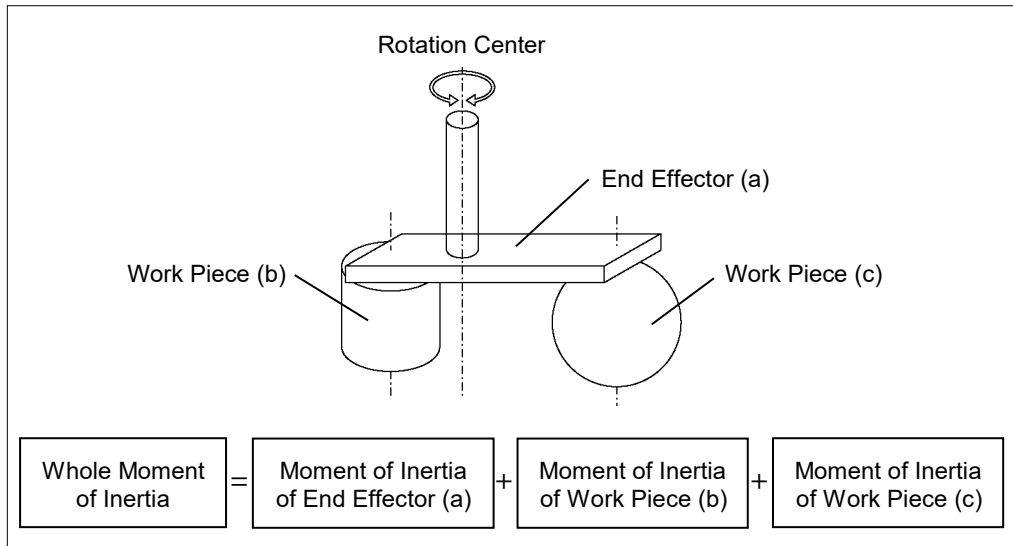

The methods for calculating the inertia moment for (a), (b), and (c) are shown in this and the next page. Figure out the whole inertia moment using the basic formulas below.

(a) Inertia moment of a rectangular parallelepiped

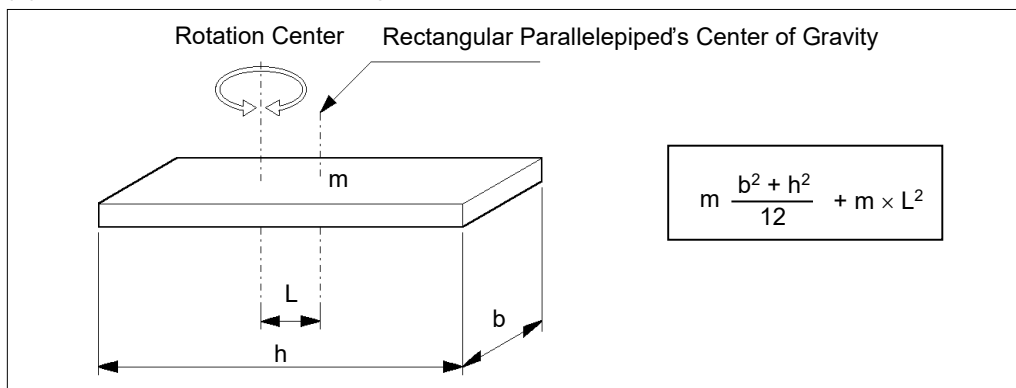

(b) Inertia moment of a cylinder

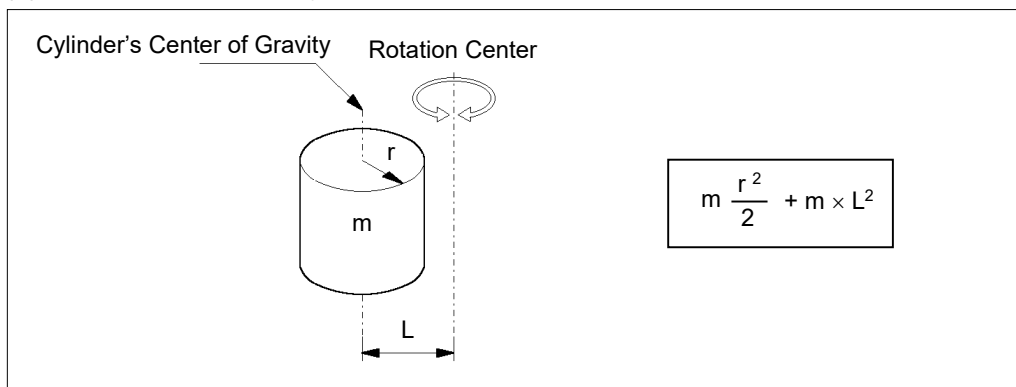

(c) Inertia moment of a sphere

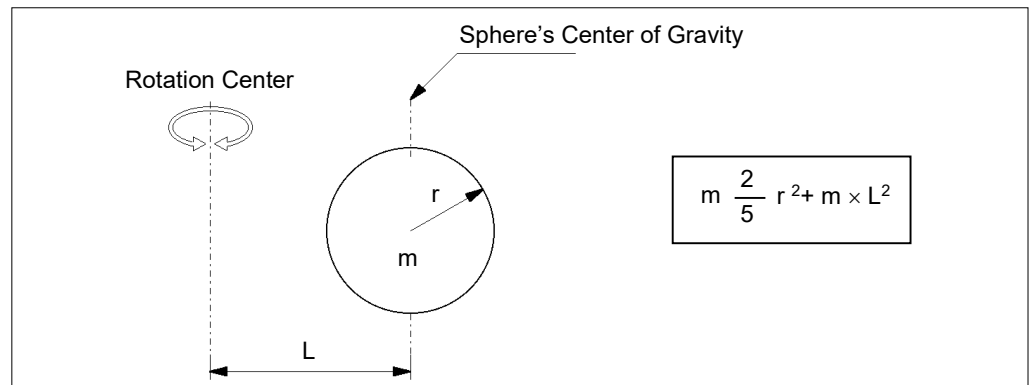

4.4 Precautions for Auto Acceleration/Deceleration

The speed and acceleration/deceleration of the Manipulator motion are automatically optimized according to the values of WEIGHT and INERTIA and the Manipulator's postures.

WEIGHT Setting

The speed and acceleration/deceleration of the Manipulator are controlled according to the load weight set by the WEIGHT command.

The more the load weight increases, the more the speed and acceleration/deceleration are reduced to prevent residual vibration.

INERTIA Setting

The acceleration/deceleration of Arm #6 are controlled according to the inertia moment set by the INERTIA command. The acceleration/deceleration of the whole Manipulator are controlled according to the eccentricity set by the INERTIA command. The more the inertia moment and eccentricity of the load increase, the more the acceleration/deceleration are reduced.

Auto Acceleration/Deceleration According to Manipulator's Posture

The acceleration/deceleration are controlled according to the Manipulator's posture. When the Manipulator extends its arms or when the movement of the Manipulator produces vibration frequently, the acceleration/deceleration are reduced.

Set appropriate values for WEIGHT and INERTIA so that the Manipulator operation is optimized.

5. Motion Range



WARNING

- When limiting the motion range for safety, be sure to set by the pulse range. Failure to do so may cause serious safety problems.

The motion range is preset at the factory as describes in “2.4 *Standard Motion Range*”. This is the maximum motion range of the Manipulator.

Motion range is set by the following two methods:

1. Setting by pulse range (for all arms)
2. Setting the Cartesian (rectangular) range in the X, Y coordinate system of the Manipulator

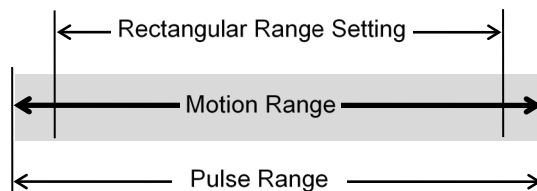

When the motion range is changed due to layout efficiency or safety, follow the descriptions in 5.1 through 5.3 to set the range.

5.1 Motion Range Setting by Pulse Range (for Each Joint)

Pulses are the basic unit of Manipulator motion. The motion range of the Manipulator is controlled by the pulse range (the lower limit and the upper limit) of each axis.

Pulse values are read from the encoder output of the servo motor.

The pulse range should be set within the maximum motion range.

NOTE



Once the Manipulator receives an operating command, it checks whether the target position specified by the command is within the pulse range before operating. If the target position is out of the set pulse range, an error occurs and the Manipulator does not move.

Epson
RC+

The pulse range can be set in [Tools]-[Robot manager]-[Range] panel.
You may also execute the Range command from the [Command Window].

5.1.1 Max. Pulse Range of Joint #1

When viewing from above, pulse values in counterclockwise direction are positive (+) and values in clockwise direction are negative (-).

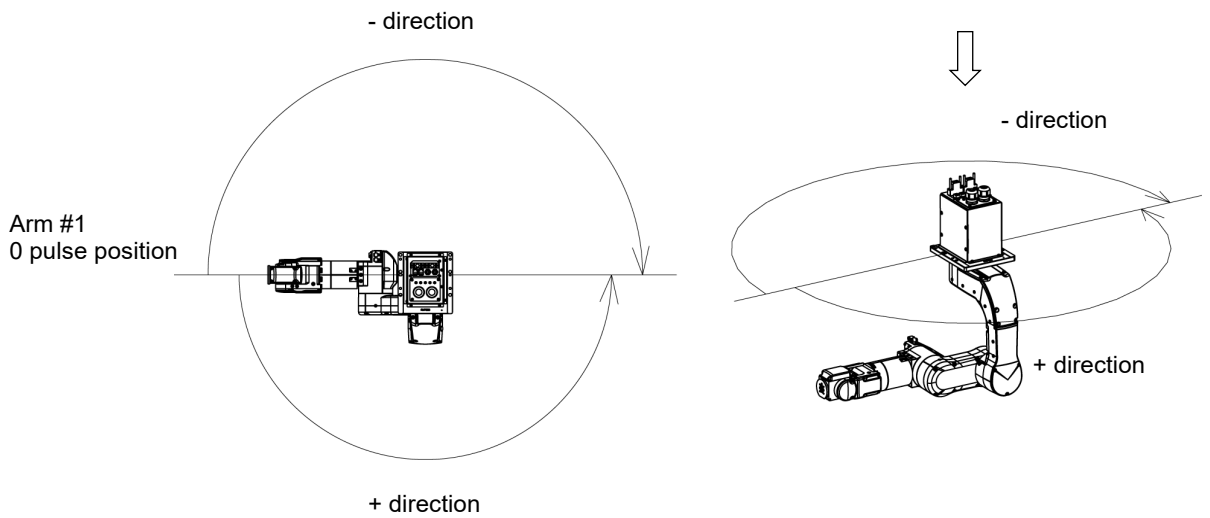

Angle (°) : ±180
 Pulse (pulse) : ±7929856

5.1.2 Max. Pulse Range of Joint #2

When viewing from the outside of the Arm #1, pulse values in counterclockwise direction are positive (+) and values in clockwise direction are negative (-).

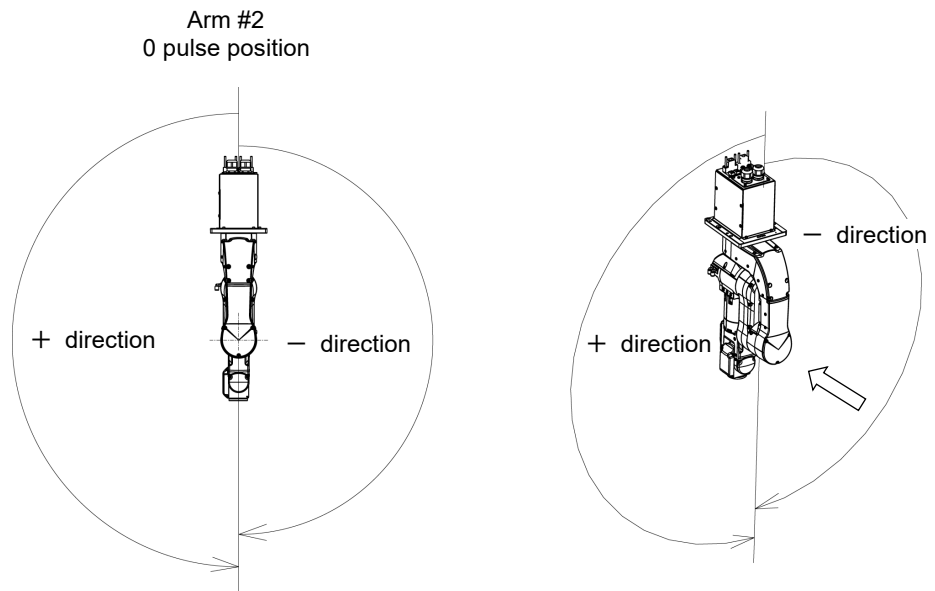

Angle (°) : ±180
 Pulse (pulse) : ±7929856

5.1.3 Max. Pulse Range of Joint #3

When viewing from the outside of the Arm #1, pulse values in counterclockwise direction are positive (+) and values in clockwise direction are negative (-).

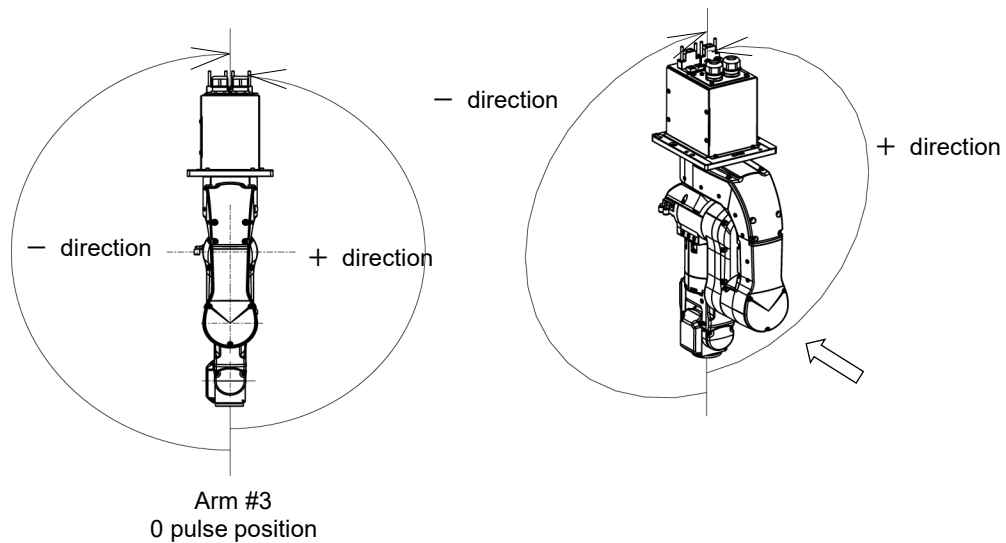

Angle (°) : ±180
Pulse (pulse) : ±6619136

5.1.4 Max. Pulse Range of Joint #4

From the angle of arm end, clockwise pulse values are positive (+) and counterclockwise pulse values are negative (-).

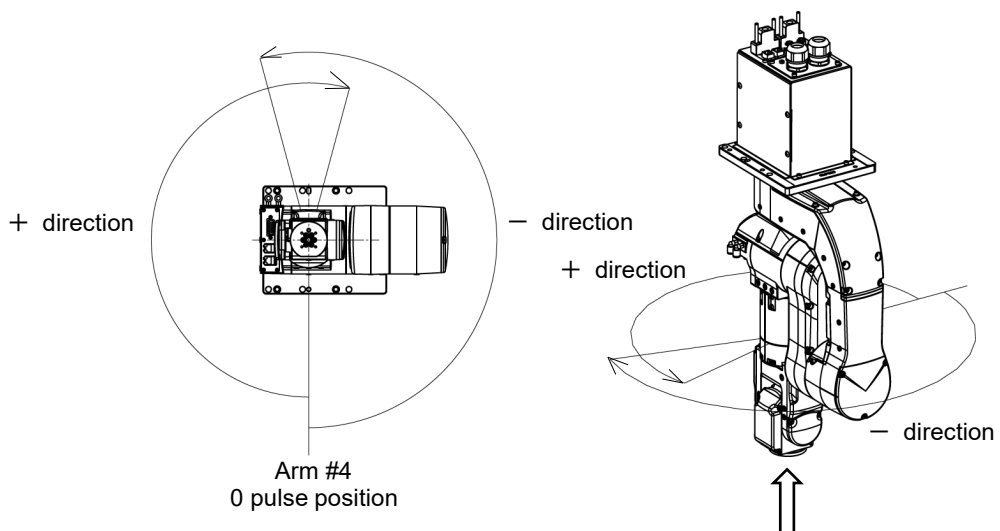

Angle (°) : ±195
Pulse (pulse) : ±7170731

5.1.5 Max. Pulse Range of Joint #5

When viewing from the outside of the Arm #1, pulse values in counterclockwise direction are positive (+) and values in clockwise direction are negative (-).

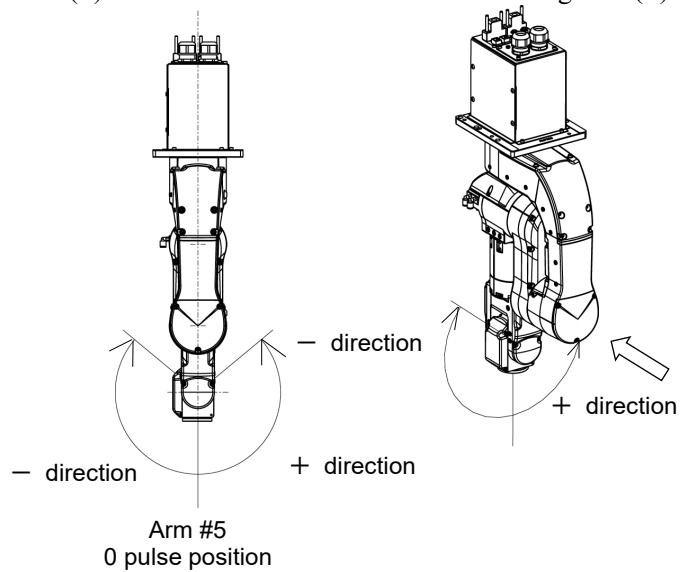

Angle (°) : ±130
 Pulse (pulse) : ±4733156

5.1.6 Max. Pulse Range of Joint #6

From the angle of arm end, clockwise pulse values are positive (+) and counterclockwise pulse values are negative (-).

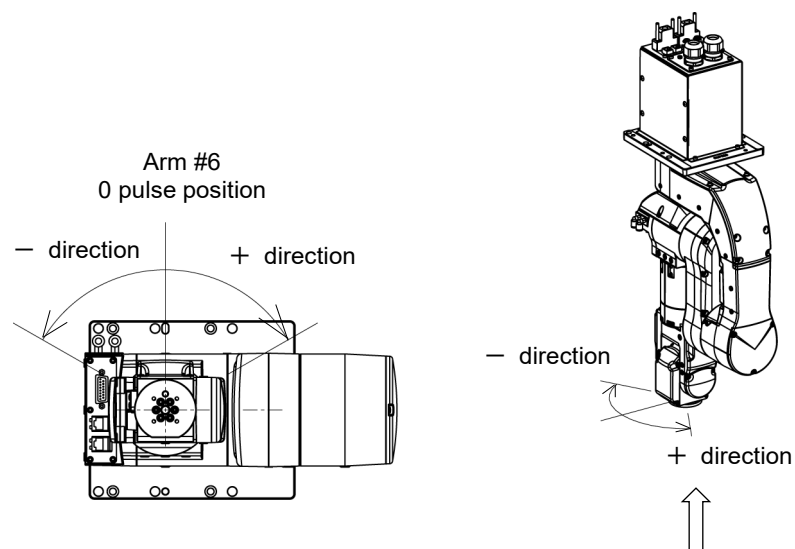

Angle (°) : ±360
 Pulse (pulse) : ±13107200

5.2 Restriction of Manipulator Operation

To prevent the arms of the Manipulator from interfering each other, the Manipulator operation is restricted as follows:

Combination restriction of joint angles

The motion ranges of the Joints #2 and #3 are defined according to the combinations of their angles. If the combination of the joint angles falls the painted areas in the below figure, the Manipulator motion will be restricted.

Combination of Joints #2 and #3:

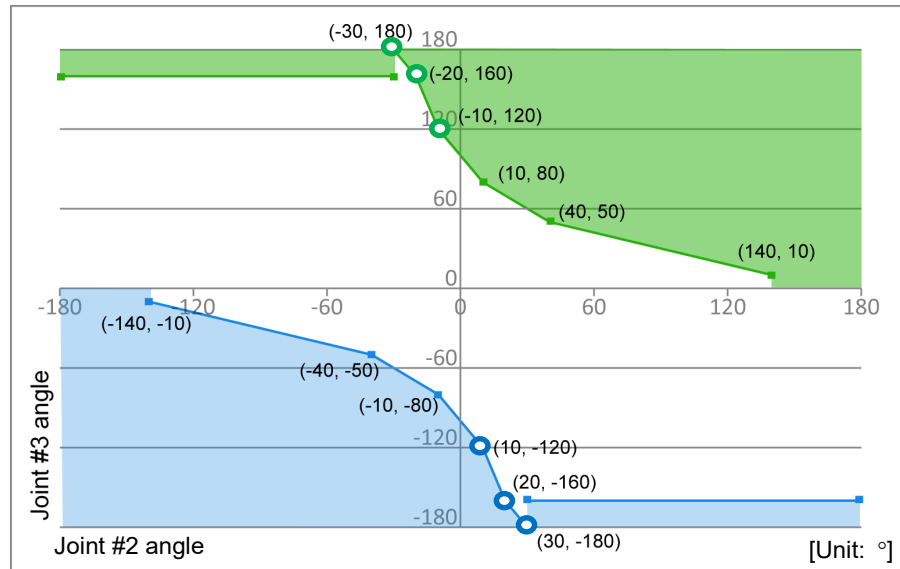

NOTE

N2 series Manipulator cannot move to the angles indicated with ● ●.

Restriction of orientation

The Manipulator cannot have the following orientation except in Jog motion.

- When the angles of both Joint #2 and #3 are positive values with Righty, Below Elbow orientation.
- When the angles of both Joint #2 and #3 are negative values with Lefty, Below Elbow orientation.

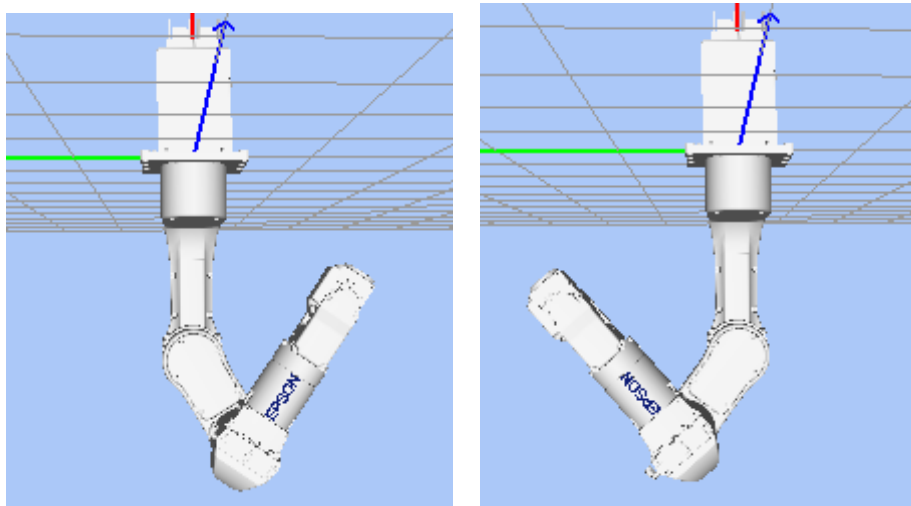

Restriction area

When the tip of the robot arm is inside the red frame area in the below figure, the Manipulator cannot move to the blue frame area.

Similarly, the Manipulator cannot move to the red frame area when the tip of the arm is in the blue frame area.

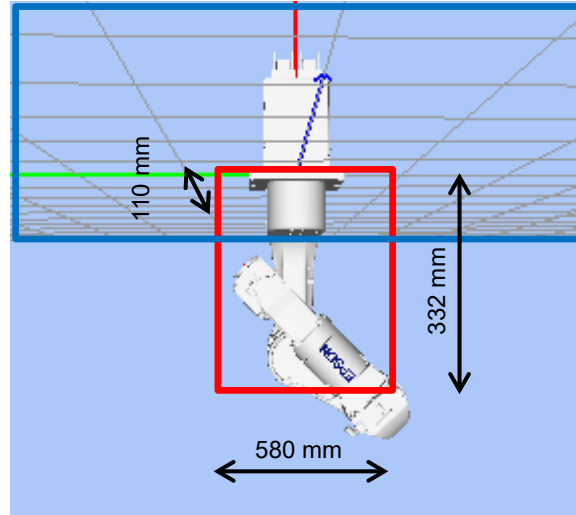

(Red frame: rectangular of 110 mm × 580 mm × 332 mm)

5.3 Coordinate System

The origin point is where the Manipulator's installation face intersects with the rotation axis of Joint #1.

For details on the coordinate system, refer to the *Epson RC+ Users Guide manual*.

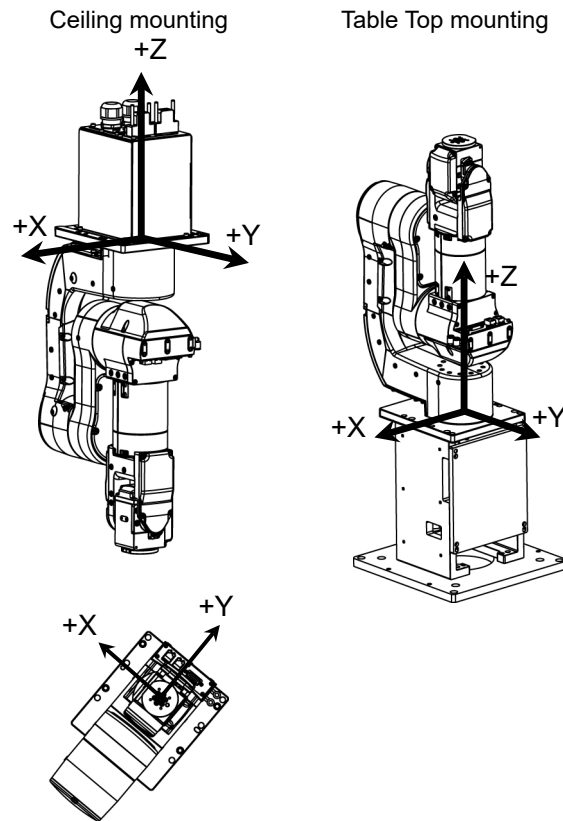

The "Table Top mount bracket" for Table Top mounting is available as an option. For details, refer to "6.6 Table Top Mount Bracket".

5.4 Changing the Robot

This section describes how to change the Manipulator model on Epson RC+.

(Default setting is “Ceiling mounting”).



CAUTION

- Changing the Manipulator should be done with great caution. It initializes the robot calibration parameters (Hofs, CalPIs), additional axis information, and PG parameter data.

Before changing the robot, make sure to save the calibration data by following the procedure below.

1. Select the Epson RC+ menu-[Setup]-[System Configuration].
2. Select [Controller]-[Robots]-[Robot**]-[Calibration] from the tree list. Then, click <Save>.

(1) Select the Epson RC+ menu-[Setup]-[System Configuration].

(2) Select [Controller]-[Robots]-[Robot**] from the tree list.

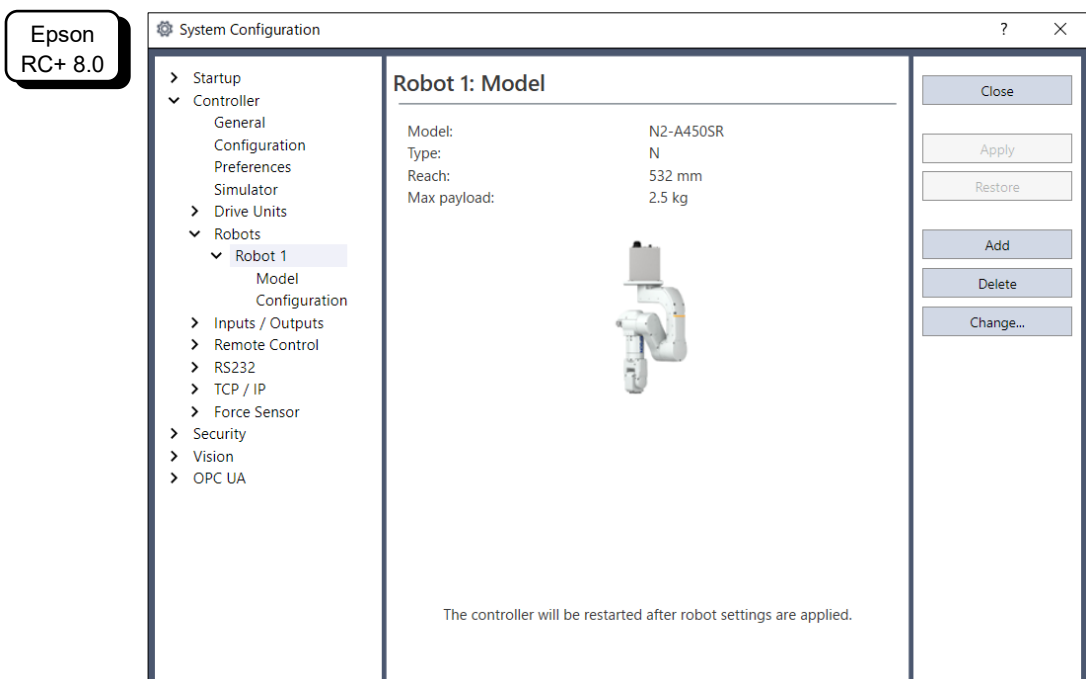
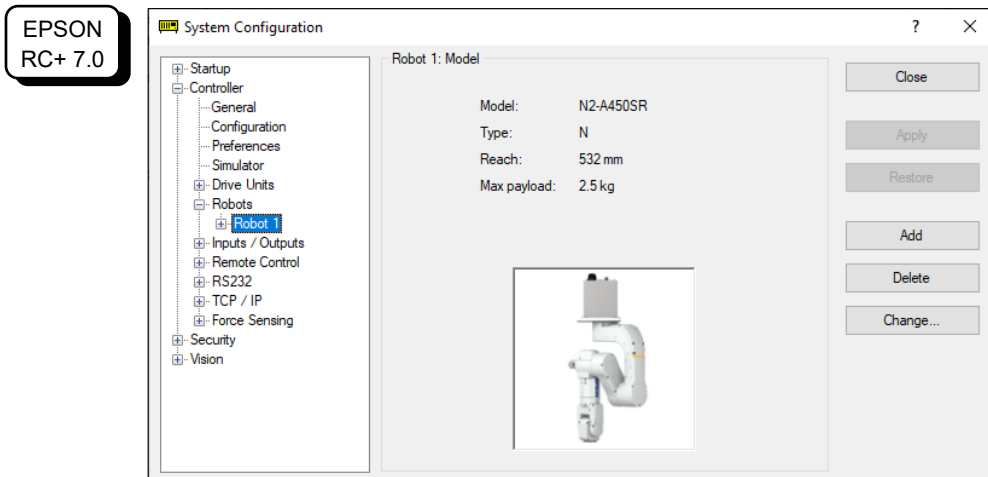

(3) Click the <Change...> button. The following dialog box will be displayed.

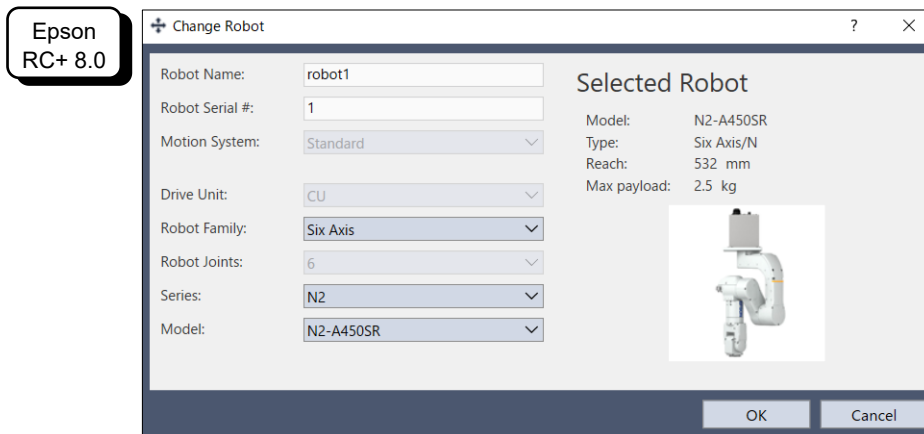
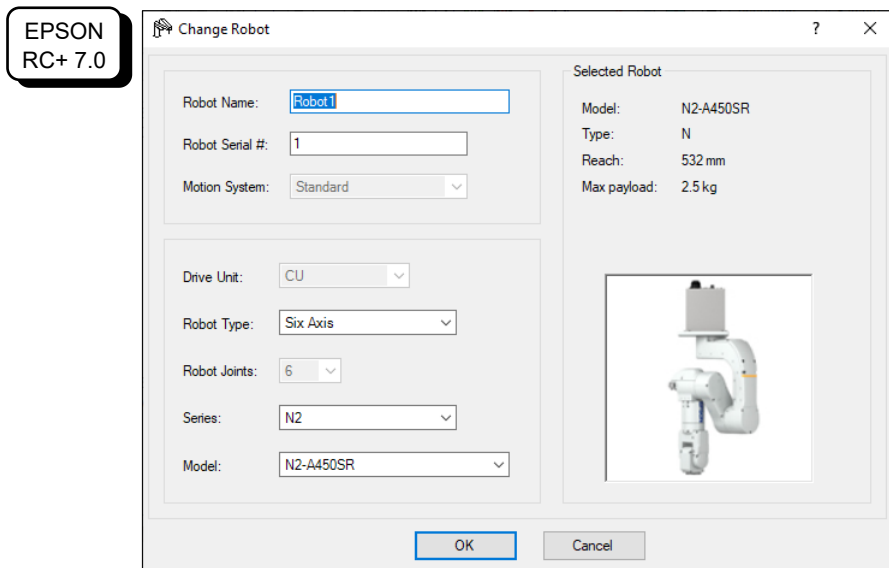

- (4) Input the robot name and serial number printed on the name plate of the Manipulator. Any serial number can be entered. However, enter the number printed on the Manipulator.
- (5) Select the robot type in the [Robot Family] box.
- (6) Select the series name of the Manipulator in the [Series] box.
- (7) Select the robot model in the [Model] box. Available robots will be displayed according to the format of the currently installed motor driver. When [Dry run] is used, all the Manipulators of the series selected in Step 6 will be displayed.
(Ceiling mount type: N2-A450SR, table top mount type: N2-A450S)
- (8) Click the <OK> button. The Controller will be restarted.

5.5 Setting the Cartesian (Rectangular) Range in the XY Coordinate System of the Manipulator

The Cartesian (rectangular) range in the XY coordinate system of the Manipulator is specified by the limited Manipulator operation area and the XYLim setting. The limited Manipulator operation area is defined so that the end effector does not interfere with the rear side of the Manipulator. The XYLim setting that you can determines the upper

and lower limits of the X and Y coordinates.

The limited Manipulator operation area and the XYLim setting apply only to the software. Therefore, these settings do not change the physical range. The maximum physical range is based on the position of the pulse range.

These settings are disabled during a joint jogging operation. Therefore, be careful not to allow the end effector to collide with the Manipulator or peripheral equipment.

Epson
RC+

Set the XYLim setting in [Tools]-[Robot manager]-[XYZ Limits] panel.
You may also execute the XYLim command from the [Command Window].

6. Options

N2 series Manipulator has the following options.

- 6.1 Brake Release Unit
- 6.2 Camera Plate Unit
- 6.3 Tool Adapter (ISO flange)
- 6.4 User Wires
- 6.5 Wiring Guide
- 6.6 Table Top Mount Bracket
- 6.7 Calibration Plate

6.1 Brake Release Unit

With the Solenoid brakes are ON (such as in Emergency Stop status), all arms except for the Arm #1 cannot be moved by hand.

You can move the Arms by hand using the brake release unit while the controller power is OFF or right after unpacking.

 WARNING	<ul style="list-style-type: none"> ■ When connecting / replacing the brake release unit or the external short connector, turn OFF the power to the Controller and the brake release unit. Connecting and disconnecting the connector while the power is ON may result in electrical shock.
--	---

 CAUTION	<ul style="list-style-type: none"> ■ Normally, release the brake of joints one by one. Take extra care if you need to release the brakes of two or more joints simultaneously. Releasing the brakes of two or more joints simultaneously may cause hands and fingers to be caught and/or equipment damage to or malfunction of the Manipulator as the arms of the Manipulator may move in unexpected directions. ■ Be careful of the arm falling when releasing the brake. While the brake is being released, the Manipulator's arm falls by its own weight. The arm falling may cause hands and fingers to be caught and/or may cause equipment damage to or malfunction of the Manipulator.
--	---

Width	180 mm
Depth	150 mm
Height	87 mm
Weight (Cables are not included.)	1.7 kg
Cable to the Manipulator	2 m
M/C Short connector	For M/C power cable short-circuit

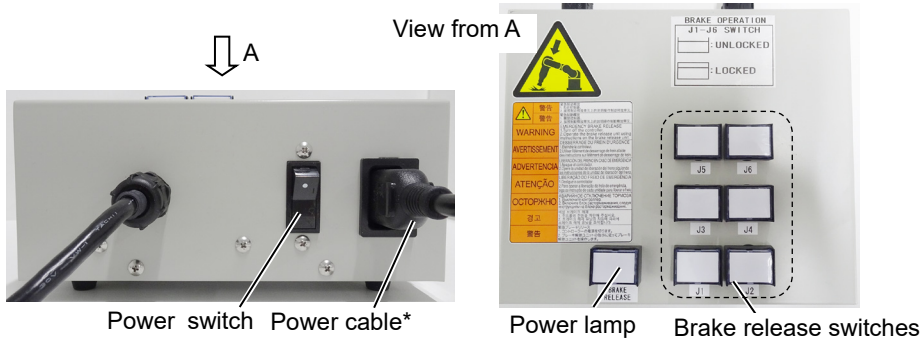

* Item you should provide

Power Cable

You must provide a power cable.

The power cable is required to meet the specifications below.

Item	Specification
(1) Plug	Comply with local safety regulation - Class I (2P+PE), AC250V, 6A or 10A Ex.: CEE Pub.7 Certified, CCC Certified, KC Certified, BS1363 Certified, PSB Certified, BIS Certified, SABS Certified - Class I (2P+PE), AC125V, 7A or 12A or, 15A etc. Ex.: UL Certified, PSE Certified, BSMI Certified
(2) Flexible cable	Comply with IEC/EN standards or local safety regulation Ex.: IEC 60227-1 General requirements IEC 60227-5 Polyvinyl chloride insulated cables of rated voltages up to and including 450/750 V - Part 5: Flexible cables (cords) EN 50525-1 General requirements EN 50525-2-11 Electric cables - Low voltage energy cables of rated voltages up to and including 450/750 V (Uo/U) - Part 2-11: Cables for general applications - Flexible cables with thermoplastic PVC insulation
(3) Appliance coupler	Comply with IEC/EN standards or local Safety regulation - IEC / EN 60320-1: Appliance couplers for household and similar general purposes - Part 1: General requirements - Standard Sheet C13: AC250V / 10A

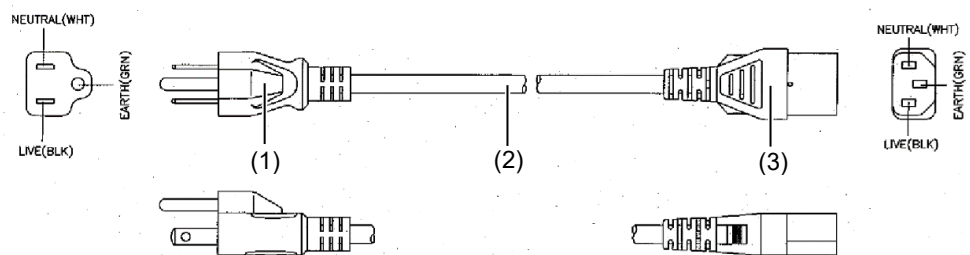

For Japan

Item	Specification
Plug	PSE Certified Class I (2P+PE), AC125V, 7A or higher
Code	PSE Certified 0.75mm ² or larger
Connector	PSE Certified IEC 60320-1 Standard Sheet C13: AC125V/10A or higher

Precautions for use

 CAUTION	<ul style="list-style-type: none"> ■ If the Manipulator is operated without connecting the brake release unit and the external short connector, the brakes cannot be released and it may cause damage on them. After using the brake release unit, be sure to connect the external short connector to the Manipulator, or check connection of the connector for the brake release unit. ■ Keep the external short connector. Otherwise you cannot release the brakes. ■ If you turn ON the brake release unit while the brake release switch is being pressed, an unintended arm may move downward. Before turning ON the brake release unit, make sure that the brake release switch is not pressed. ■ If you turn ON the brake release unit without the connector, it may lead to the short for the male pin used in the connector. Before turning ON the brake release unit, make sure that the connector is connected.
--	--

Mount the brake release unit

- (1) Turn OFF the controller.
- (2) If the M/C power cable is not connected to the Controller:
 Connect the M/C short connector,
 or connect the Controller.
 (Keep the Controller power OFF)

 The M/C short connector can be purchased singly.



If the M/C power cable is already connected to the Controller:
 Go to the step (3).



- (3) Remove the external short connector.

External short connector

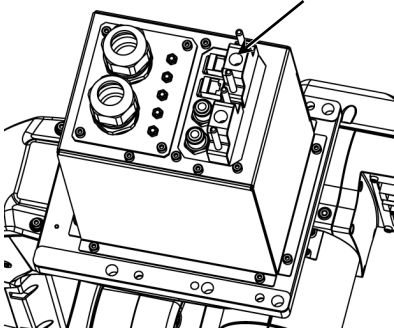

- (4) Connect the brake release unit to the connector of the connection cable.

NOTE  The connection cable connector and the adjacent user cable connector have the same shape. Be careful not to connect the wrong connector.

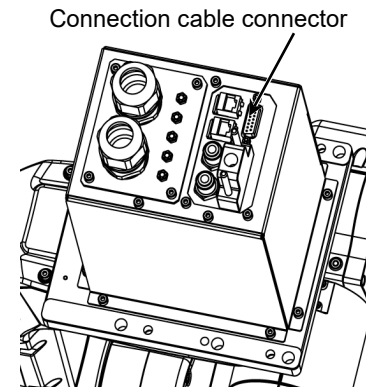

Remove the brake release unit

- (1) Turn OFF the brake release unit.
- (2) Remove the power cable of the brake release unit.
- (3) Disconnect the brake release unit from the connector of the connection cable.
- (4) If the M/C short connector is connected to the M/C power cable in the Installation step (2), remove the short connector.

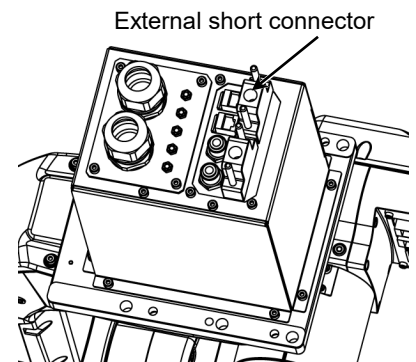

- (5) Connect the external short connector to the connector of the connection cable

NOTE  The connection cable connector and the adjacent user cable connector have the same shape. Be careful not to connect the wrong connector.

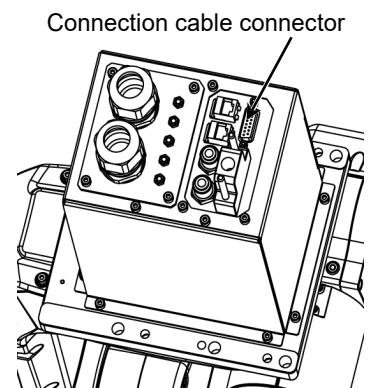

How to use the brake release unit

 CAUTION	<ul style="list-style-type: none"> ■ Be careful of the arm falling when releasing the brake. While the brake is being released, the Manipulator's arm falls by its own weight. The arm falling may cause hands and fingers to be caught and/or may cause equipment damage to or malfunction of the Manipulator. ■ If the arm you released its brake moves awkwardly or faster than usual, stop the operation promptly and contact the supplier of your region. The brake release unit may be broken. If you keep operating the Manipulator, it may lead to the breakdown of the Manipulator or you may get your hand or fingers caught.
--	---

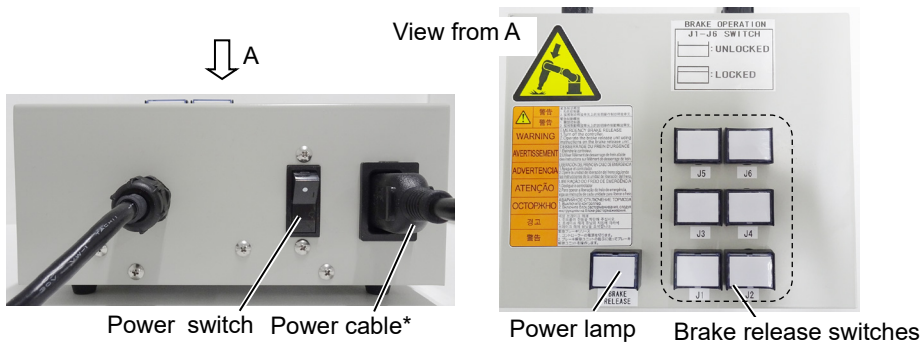

* Item you should provide

- (1) Refer to “Mount the brake release unit” above to connect the brake release unit to the connector of the connection cable.
- (2) Plug the power cable into the brake release unit.
- (3) Plug the power cable into the power supply plug.
- (4) Turn ON the brake release unit.
When the brake release unit is enabled, the power lamp lights up.
- (5) Press the switch of the arm (J2 to J6) you want to move and then move the arm.
Press the switch again. The brake will be released.
The brake will be enabled by pressing the switch once again.

NOTE  Move the arm the brake is released by two persons or more (one presses the switch and one moves the arm). The arm can be very heavy and needs the significant force to move.

6.2 Camera Plate Unit

By using the camera plate unit, you can mount the camera to the N2 series Manipulator.

Appearance of arm end with camera

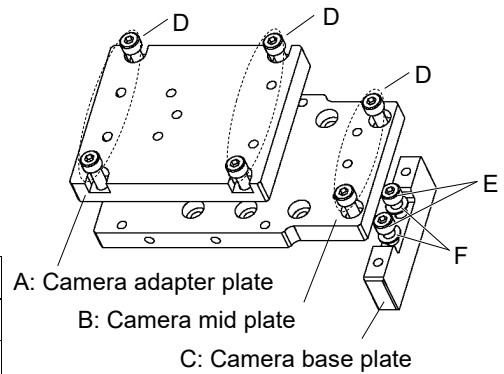
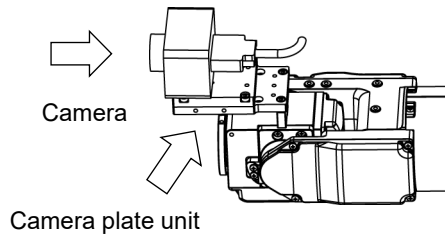

Parts included		unit
A	Camera adapter plate	1
B	Camera mid plate	1
C	Camera base plate	1
D	Hexagon socket head screws M4×12	6
E	Hexagon socket head screws M4×20	2
F	Plain washer for M4 (small washer)	2

Installation

NOTE For details of tightening the hexagon socket head screws, refer to “Regular Inspection for N2 Manipulator”-“1.4 Tightening Hexagon Socket Head Bolts”.

Mounting holes for the camera base plate on the N2 series Manipulator

Camera base plate mounting hole

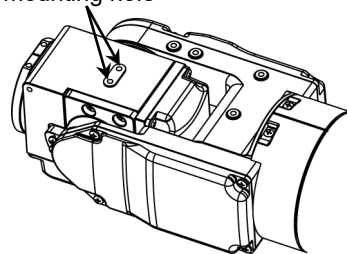

For the installation steps, refer to the following manual:

Epson RC+ Option Vision Guide Hardware & Setup Hardware - 6-Axis Robot

Dimension of the camera plate unit



Dimensions X and Y vary depending on the position of the camera mid plate and camera size. Refer to the table below for the values.

Camera mid plate

The camera mid plate uses the mounting holes A to D.

By using the different mounting holes, it can be mounted to the camera base plate in the different four positions.

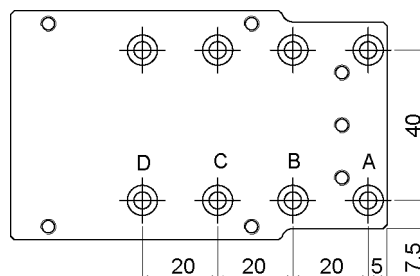

Camera and N2 series Manipulator Joint #5 motion range (reference values)

The Joint #5 motion range varies depending on the mounting position of camera mid plate and the camera you are using.

The table below shows the motion range (reference values) based on the available cameras for this option and the mounting positions of the camera mid plate. The values in the table may vary depending on how to secure the cables.

By changing the Y position, you can extend the distance from the end effector mounting surface to the camera. Also, you can attach the larger end effector. However, be careful about the Joint #5 motion range that will be limited in this case.

(°=degree)

	A	B	C	D	X
USB camera, GigE camera	-135° to +70°	-135° to +53°	-135° to +33°	-135° to +13°	93 mm

	A	B	C	D
Y	38 mm	18 mm	-2 mm	-22 mm

Direction of the Joint #5 motion

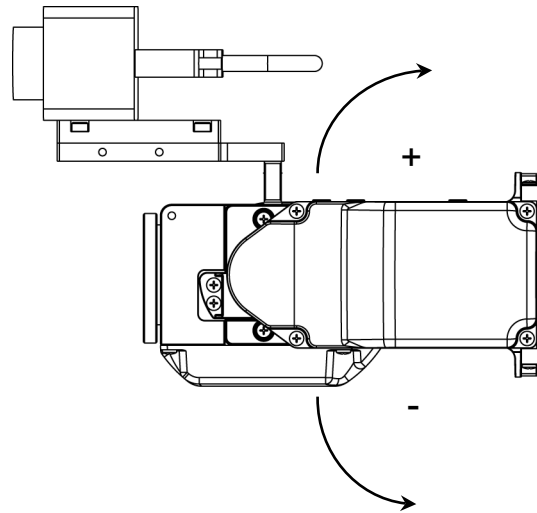

6.3 Tool Adapter (ISO Flange)

By using the tool adapter, you can mount the end effector whose dimensions are designed for the ISO flange to the C8 series Manipulators.

Parts included	Unit
ISO flange	1
Pin	1
Hexagon socket head cap bolts M4×12	4

Dimensions of ISO flange

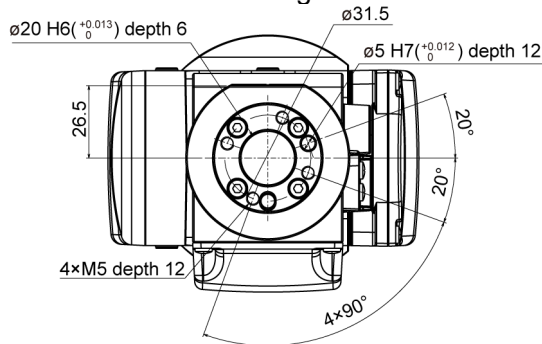

* Each dimension and tolerance complies with ISO9409-1-31.5-4-M5.

To mount the ISO flange



For details of tightening the hexagon socket head screws, refer to “Regular Inspection for N2 Manipulator”-“1.4 Tightening Hexagon Socket Head Bolts”.

- (1) Press-fit the pin to the Arm #6 end flange.

Pin projection : 10.5 mm from the flange

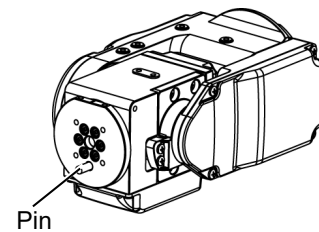

- (2) Align the pin and the pin hole on the flange, and then mount the flange.

Hexagon socket head cap bolts: 4-M4×12

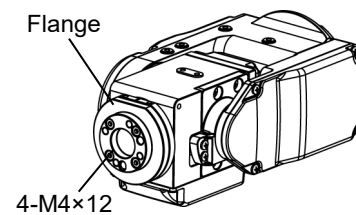

6.4 User Wires

Use the following included items when using the internal wiring for the end effector drive.

Included items

The following parts are attached to the Manipulator as standard.

- Standard fitting for customer use
- Standard user connector kit

Standard fittings kit for customer use (ø6 elbow)

Item	Qty.	Manufacturer	Standard
ø6 elbow fitting	2	SMC	KQ2L06-M5N

Standard user connector kit (D-sub): Option

Item	Qty.	Manufacturer	Standard
Connector	2	JAE	DA-15PF-N (Solder type)
Clamp hood	2	HRS	HDA-CTH(4-40)(10) (Connector setscrew: #4-40 UNC)

6.5 Wiring Guide

This option is used for installing the user wires and tubes.

Use this option to fix the cables and tubes to the end effector when installing the internal wiring and tubing for the end effector drive.

Item	Qty.
Wiring Guide	1
Hexagon socket head cap bolts M4×8	2

NOTE For details of tightening the hexagon socket head screws, refer to “Regular Inspection for N2 Manipulator”-“1.4 Tightening Hexagon Socket Head Bolts”.

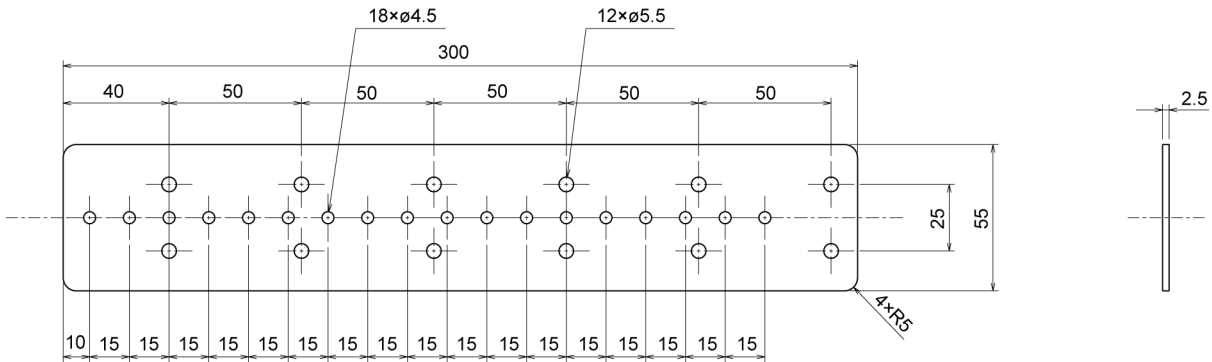

Fix the wiring guide to the Arm with the screws (M4×8). Adjust position up and down according to the marginal length of the cables and tubes.

Fix the cables and tubes along the wiring guide using the wire ties, and then install wiring to the end effector while leaving marginal length.

Installation of Wiring Guide

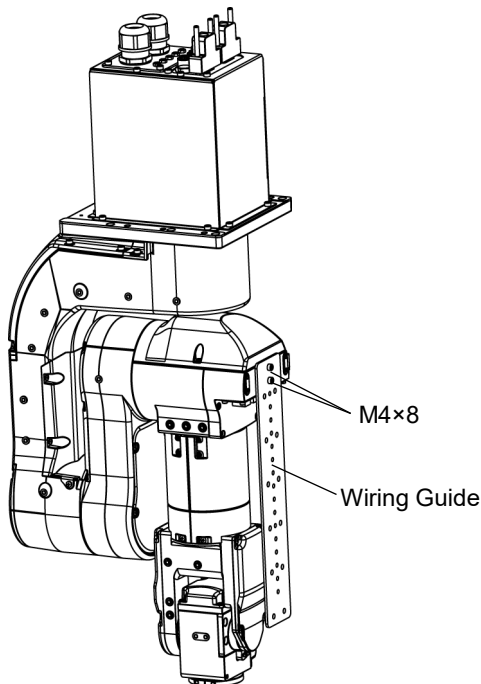

Reference: Example of wiring

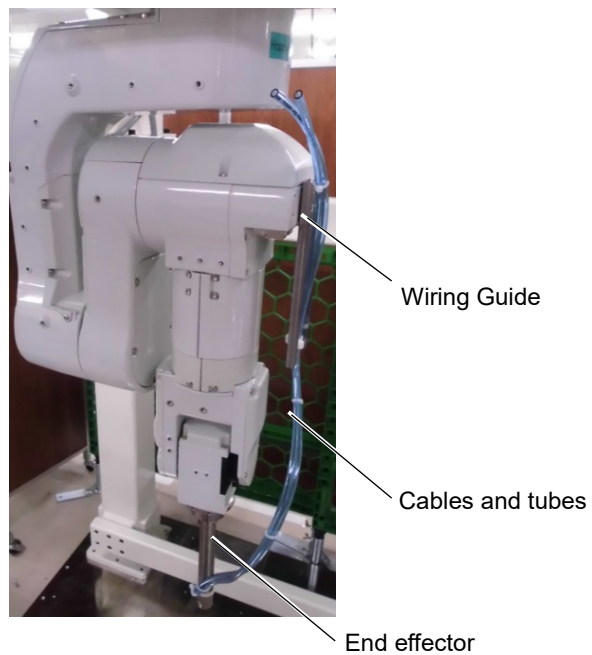

6.6 Table Top Mount Bracket

This option is used for installing the Manipulator by table top mounting. The bracket also can be prepared by the customers. The following describes our recommended bracket.



To perform maintenance on the base of table top mounting Manipulator, such as battery replacement, the Manipulator needs to be removed from the table top mount bracket.

Table top Bracket Parts List

Item	Qty.	Material
Table top mount plate 1	1	A5052P
Table top mount plate 2	1	
Table top mount plate 3	1	
Pin ($\phi 6 \times 15$)	4	-
Pin ($\phi 6 \times 25$)	2	-
Hexagon socket head cap bolts (M4 $\times 15$)	4	-

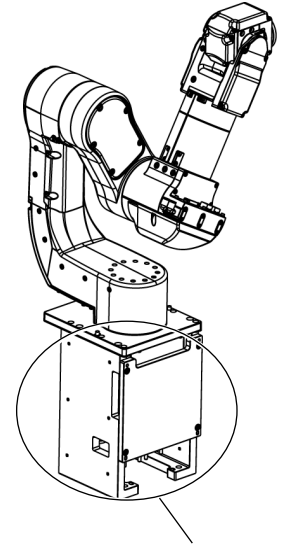
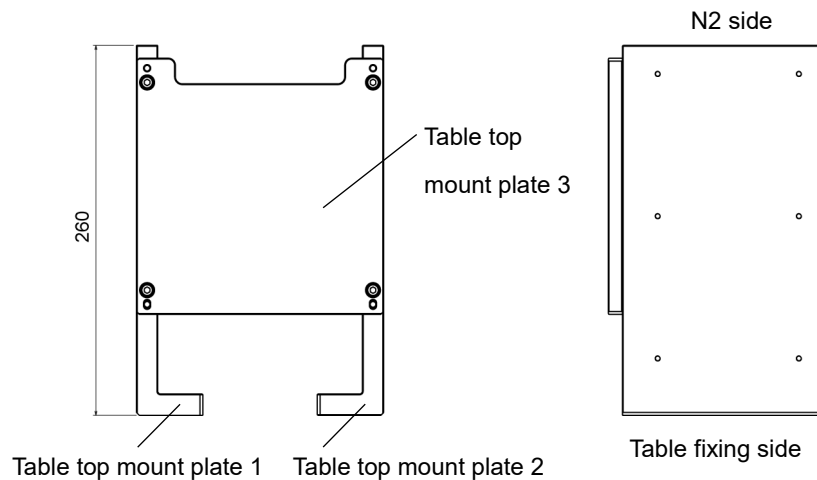
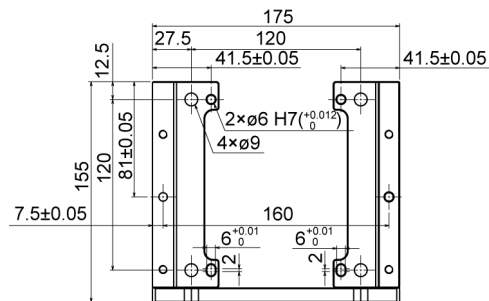



Table Top Mount Bracket

Rough dimensions



NOTE  For details of tightening the hexagon socket head screws, refer to “Regular Inspection for N2 Manipulator”-“1.4 Tightening Hexagon Socket Head Bolts”.

- (1) Assemble the table top mount plates 1, 2, and 3.

Pin ($\varnothing 4 \times 15$)

Hexagon socket head cap bolts (M5 \times 15), plain washer for M5

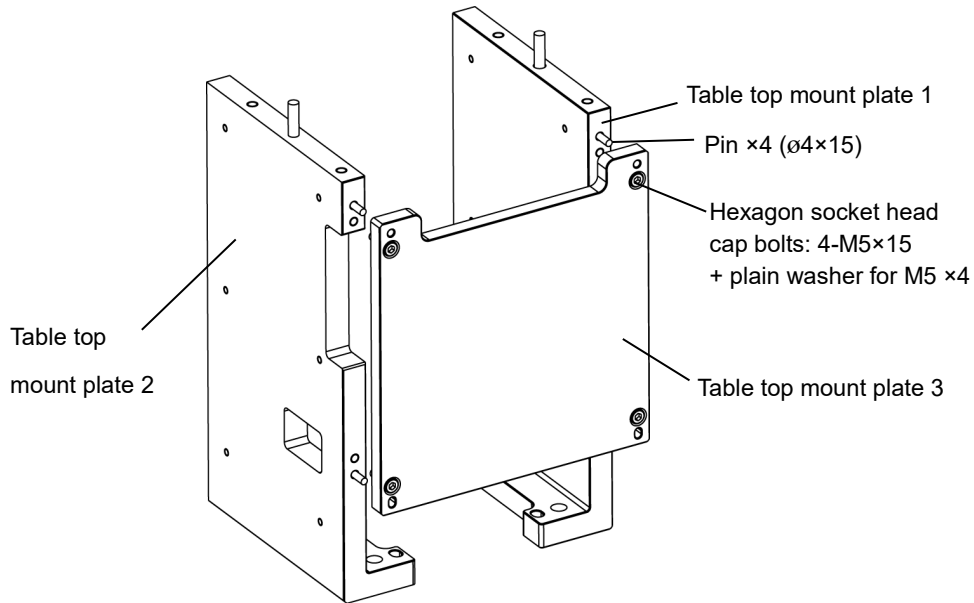

- (2) Fix the bracket to the base table.

Adjust position between the bracket and the table by the table top mount plate 1 or 2.
Fix the table top mount plates 1 and 2 to the table with screws.

Hexagon socket head cap bolts for M8 (4 bolts)

- (3) Fix the Manipulator on the table top mount bracket.

Adjust position between the bracket and the Manipulator by the attached pin ($\varnothing 6 \times 25$).
Fix the bracket and the Manipulator.

Hexagon socket head cap bolts (4-M6 \times 20)

6.7 Calibration Plate

This option is used for calibration*.

* Calibration

After parts have been replaced (actuator units, timing belts, etc.), the Manipulator cannot perform positioning properly because a gap exists between the origin stored in each actuator unit and its corresponding origin stored in the Controller.

After replacing the parts, it is necessary to match these origins.

The process of aligning the two origins is called “Calibration”.

There are two methods to perform calibration.

Using the calibration plate

Using the origin position marks (0 pulse position)

Using the calibration plate helps to perform calibration with higher accuracy than calibration using the origin position marks.

For details of calibration, refer to *N series Maintenance Manual “N2 Maintenance - Calibration”*.

Calibration Plate Parts List

Item	Qty.
Calibration plate (weight: 2.5 kg)	1
Arm #4 offset jig	1
Arm #6 offset jig	1
Hexagon socket head cap bolts (M4×15)	8
Hexagon socket head cap bolts (M4×20)	4
J1 origin position pin	1
Hexagon socket head cap bolts (M2.5×20)	1
Plain washer for M4 (small washer)	8

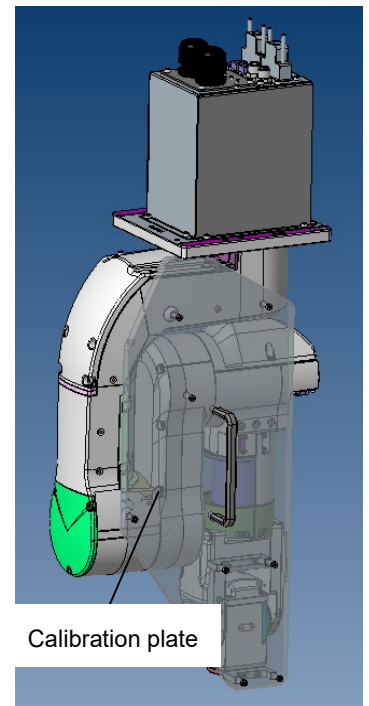

N6 Manipulator

This volume contains information for setup and operation of the Manipulators.
Please read this volume thoroughly before setting up and operating the Manipulators.

1. Safety



Unpacking, and transportation of the Manipulators and robotic equipment shall be performed by personnel who has taken robot system training held by us and suppliers and should conform to all national and local codes.

Please read this manual and other related manuals before installing the robot system or before connecting cables.

Keep this manual handy for easy access at all times.

1.1 Conventions

Important safety considerations are indicated throughout the manual by the following symbols. Be sure to read the descriptions shown with each symbol.

 WARNING	This symbol indicates that a danger of possible serious injury or death exists if the associated instructions are not followed properly.
 WARNING	This symbol indicates that a danger of possible serious injury caused by electric shock exists if the associated instructions are not followed properly.
 CAUTION	This symbol indicates that a danger of possible harm to people or physical damage to equipment and facilities exists if the associated instructions are not followed properly.

1.2 Design and Installation Safety

This product is intended for transporting and assembling parts in a safely isolated area. Design and installation of robot system shall be performed by personnel who has taken robot system training held by us and suppliers.

To ensure safety, a safeguard must be installed for the robot system. For details on the safeguard, refer to the *Installation and Design Precautions* in the *Safety* chapter of the Epson RC+ User's Guide.



The following items are safety precautions for design personnel:

 <p>WARNING</p>	<ul style="list-style-type: none">■ Personnel who design and/or construct the robot system with this product must read "<i>Safety Manual</i>". Designing and/or constructing the robot system without understanding the safety requirements is extremely hazardous, and may result in serious bodily injury and/or severe equipment damage to the robot system.■ The Manipulator and the Controller must be used within the environmental conditions described in their respective manuals. This product has been designed and manufactured strictly for use in a normal indoor environment. Using the product in an environment that exceeds the specified environmental conditions may not only shorten the life of the product but may also cause serious safety problems.■ The robot system must be used within the installation requirements described in the manuals. Using the robot system outside of the installation requirements may not only shorten the life of the product but also cause serious safety problems.■ When designing or installing a robot system, wear at least the following protective gear. Working without protective gear may cause serious safety problems.<ul style="list-style-type: none">Work clothes suitable for workHelmetSafety shoes
--	---

Further precautions for installation are described in the chapter "*3. Environment and Installation*". Please read this chapter carefully to understand safe installation procedures before installing the robots and robotic equipment.

1.3 Operation Safety

The following items are safety precautions for qualified Operator personnel:

 WARNING	<ul style="list-style-type: none"> ■ Please carefully read "<i>Safety Manual</i>". Operating the robot system without understanding the safety precautions is extremely hazardous and may result in serious bodily injury and/or severe equipment damage to the robot system. ■ Do not enter the operating area of the Manipulator while the power to the robot system is turned ON. Entering the operating area with the power ON is extremely hazardous and may cause serious safety problems as the Manipulator may move even if it seems to be stopped. ■ Before operating the robot system, make sure that no one is inside the safeguarded area. The robot system can be operated in the mode for teaching even when someone is inside the safeguarded area. The motion of the Manipulator is always in restricted status (low speeds and low power) to secure the safety of an operator. However, operating the robot system while someone is inside the safeguarded area is extremely hazardous and may result in serious safety problems in case that the Manipulator moves unexpectedly. ■ Immediately press the Emergency Stop switch whenever the Manipulator moves abnormally during operation. Continuing the operation while the Manipulator moves abnormally is extremely hazardous and may result in serious bodily injury and/or severe equipment change to the robot system.
 WARNING	<ul style="list-style-type: none"> ■ Be sure to connect the AC power cable to a power receptacle. DO NOT connect it directly to a factory power source. To shut off power to the robot system, disconnect the power plug from the power source. Performing any work while connecting the AC power cable to a factory power source is extremely hazardous and may result in electric shock and/or malfunction of the robot system. ■ Before performing any replacement procedure, turn OFF the Controller and related equipment, and then disconnect the power plug from the power source. Performing any replacement procedure with the power ON is extremely hazardous and may result in electric shock and/or malfunction of the robot system. ■ Do not connect or disconnect the motor connectors while the power to the robot system is turned ON. Connecting or disconnecting the motor connectors with the power ON is extremely hazardous and may result in serious bodily injury as the Manipulator may move abnormally, and also may result in electric shock and/or malfunction of the robot system.



CAUTION

- Whenever possible, only one person should operate the robot system. If it is necessary to operate the robot system with more than one person, ensure that all people involved communicate with each other as to what they are doing and take all necessary safety precautions.
- If the joints are operated repeatedly with the operating angle less than 5 degrees, they may get damaged early because the bearings are likely to cause oil film shortage in such situation. To prevent early breakdown, move each joint larger than 30 degrees for about once an hour.
- Oscillation (resonance) may occur continuously depending on the combination of robot motion speed, Arm orientation, and end effector load. Oscillation arises from natural oscillation frequency of the Arm and can be controlled by following measures.

- Changing Manipulator speed
- Changing the teach points
- Changing the end effector load

1.4 Emergency Stop

If the Manipulator moves abnormally during operation, immediately press the Emergency Stop switch. Pressing the Emergency Stop switch immediately changes the Manipulator to deceleration motion and stops it at the maximum deceleration speed.

Avoid pressing the Emergency Stop switch unnecessarily while the Manipulator is running normally.

- The Manipulator may hit the peripheral equipment.

When you press the Emergency Stop switch, the operating trajectory until the robot system stops is different from that in normal operation.

- The life of the brakes will be shortened.

The brakes are locked and the brake friction plate is worn.

Normal brake life cycle: About 2 years (when the brakes are used 100 times/day)

However, the rough normal relay life is approximately 20,000 times. If you press the emergency stop switch unnecessarily, the life of the relay will be shortened.

- Impact is applied on the reduction gear unit, and it may result in the short life of the reduction gear unit.

To place the robot system in emergency mode during normal operation, press the Emergency Stop switch while the Manipulator is not moving.

Refer to the Controller manual for instructions on how to wire the Emergency Stop switch circuit.

Do not turn OFF the Controller while the Manipulator is operating.

If you attempt to stop the Manipulator in emergency situations, make sure to stop the Manipulator using the E-STOP of the Controller.

If the Manipulator is stopped by turning OFF the Controller while it is operating, the following problems may occur.

Reduction of the life and damage of the reduction gear unit

Position gap at the joints

In addition, if the Controller was forced to be turned OFF by blackouts and the like while the Manipulator is operating, make sure to check the following points after power restoration.

Whether or not the reduction gear is damaged

Whether or not the joints are in their proper positions

If there is a position gap, perform calibration by referring to “*N series Maintenance Manual-N6 Maintenance - Calibration*”.

Before using the Emergency Stop switch, be aware of the followings.

- The Emergency Stop (E-STOP) switch should be used to stop the Manipulator only in case of emergencies.
- To stop the Manipulator operating the program except in emergency, use Pause (halt) or STOP (program stop) commands.
Pause and STOP commands do not turn OFF the motors. Therefore, the brake does not function.
- For the Safeguard system, do not use the circuit for E-STOP.

To check brake problems, refer to “*Regular Inspection 2. Regular Inspection for N6 Manipulator*”.

NOTE



Test pulse cannot be used with the emergency stop input of this model.

Stopping distance in emergency

The Manipulator in operation cannot stop immediately after the Emergency Stop switch is pressed. In addition, stopping time and stopping distance vary by following factors:

Hand weight	WEIGHT Setting	ACCEL Setting
Workpiece weight	SPEED Setting	Posture etc.

For stopping time and stopping distance of the Manipulator, refer to “*Appendix B: Stopping Time and Stopping Distance in Emergency*”.

1.5 Safeguard

To ensure safe operation, install a safety system using safety doors, light curtains, safety floor mats, etc.

When a closed safeguard is open during robot motion, the safeguard interlock function operates. The robot stops immediately and enters into pause state. Then, all robot motors are turned OFF. The descriptions below explain how the safeguard input works.

Safeguard open : The robot stops immediately, motors are turned OFF, and further operation is impossible until either the safeguard is closed or TEACH or TEST mode is turned ON and the enable circuit is engaged.

Safeguard closed : The robot can automatically operate in unrestricted (high power) state.

Do not open the safeguard unnecessarily while motor is ON. Frequent safeguard inputs affect the life of the relay.

Rough normal relay life: Approximately 20,000 times

For the safeguard, do not use the E-STOP circuit.

For details of wiring instructions, refer to the following manual:

RC700 series Manual - Functions required for designing - EMERGENCY

For details of Safeguard, refer to the following manual:

RC700 series Manual - Installation - Connection to EMERGENCY Connector



Test pulse cannot be used with the safeguard input of this model.



WARNING

- The EMERGENCY connector on the controller has a safeguard input circuit to connect the safety device interlock switch. To protect operators working near the robot, be sure to connect the interlock switch and make sure that it works properly.

- The time to stop the robot and the stopping distance by the safeguard interlock function will change depending on the conditions of use. Be sure to confirm that safety is ensured according to the installation environment of the robot.

Stopping distance when the safeguard is opened

The Manipulator in operation cannot stop immediately after the safeguard is opened. In addition, stopping time and stopping distance vary by following factors:

Hand weight	WEIGHT Setting	ACCEL Setting
Workpiece weight	SPEED Setting	Posture etc.

For stopping time and stopping distance of the Manipulator, refer to “Appendix C: Stopping Time and Stopping Distance When the Safeguard is Opened”.

1.6 How to Move Arms with the Electromagnetic Brake

There are two methods to release the Electromagnetic brake.

Follow either method to release the Electromagnetic brake and move the arm manually.

The Joint #1 is not equipped with the Electromagnetic brake.

Moving the arm using the brake release unit:

Follow the method when you just unpack the delivered boxes or when the Controller does not start up yet.

The brake release unit is available as an option.

For details, refer to “6. Options”.

Moving the arm using the software:

Follow the method when you can use the software.



CAUTION

- Normally, release the brake of joints one by one. Take extra care if you need to release the brakes of two or more joints simultaneously. Releasing the brakes of two or more joints simultaneously may cause hands and fingers to be caught and/or equipment damage to or malfunction of the Manipulator as the arms of the Manipulator may move in unexpected directions.
- Be careful of the arm falling when releasing the brake. While the brake is being released, the Manipulator’s arm falls by its own weight. The arm falling may cause hands and fingers to be caught and/or may cause equipment damage to or malfunction of the Manipulator.
- Before releasing the brake, be sure to keep the Emergency Stop switch handy so that you can immediately press the Emergency Stop switch. Otherwise, you cannot immediately stop the arm falling due to an erroneous operation. The arm falling may cause equipment damage to and/or malfunction of the Manipulator.

Epson
RC+

After releasing the Emergency Stop switch, execute the following command in [Command Window].

```
>Reset
```

```
>Brake Off, [the number (from 2 to 6) corresponding to the arm whose brake will be turned OFF]
```

Execute the following command to turn ON the brake again.

```
>Brake On, [The number (from 2 to 6) corresponding to the arm whose brake will be turned ON]
```

While the Electromagnetic brakes are ON (such as in emergency mode), you cannot move any arms except for Arm #1 by pushing manually.

Arm Motion

N6-A1000**

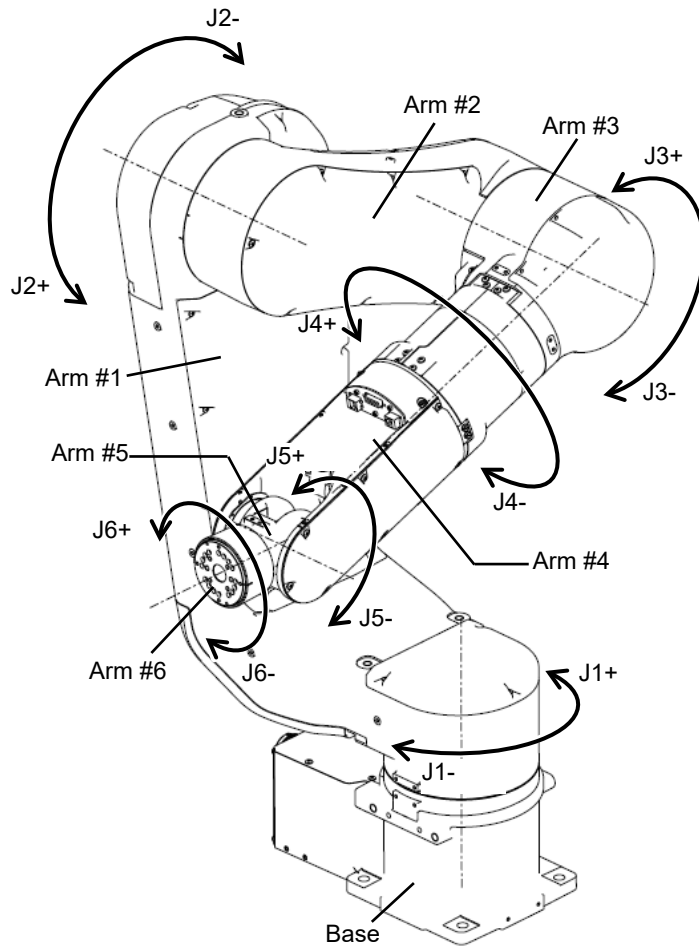

N6-A850**R

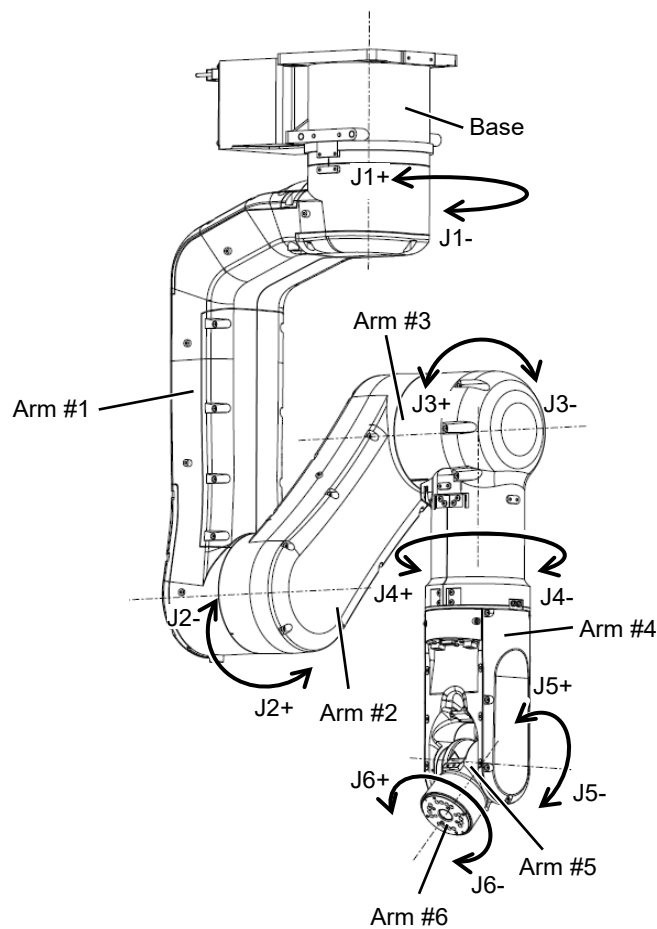

1.7 Precaution for Operation in Low Power Status

In the low power status, the Manipulator operates at low speed and low torque. Carefully operate the Manipulator since it may get your hands or fingers caught during operation. The Manipulator may also collide with peripheral equipment and cause equipment damage to or malfunction of the Manipulator.



CAUTION

- Carefully operate the Manipulator in the low power status. A comparatively high joint torque may be generated. It may cause your hands and fingers caught and/or cause equipment damage to or malfunction of the Manipulator as it may collide with peripheral equipment.







1.8 Warning Labels

The Manipulator has the following warning labels.

The warning labels are attached around the locations where specific dangers exist.

Be sure to comply with descriptions and warnings on the labels to operate and maintain the Manipulator safely.

Do not tear, damage, or remove the warning labels. Use meticulous care when handling those parts or units to which the following warning labels are attached as well as the nearby areas.

Location	Warning Label	NOTE
A	 <div data-bbox="646 627 853 817"> <p>警告 WARNING 警告 AVERTISSEMENT 警告 ADVERTENCIA 警告 ATENÇÃO 경고 OSTOPZHKO</p> <p>当心倾下 TIP-OVER HAZARD 当心落下 RISQUE DE BASCULEMENT 転倒の危険 PELIGRO DE VUELCO 전도 위험 PERIGO DE QUEDA опасность опрокидывания ОПАСНОСТЬ ОПРОКИДЫВАНИЯ</p> </div>	<p>To avoid the Manipulator from falling, support the Manipulator before removing the base mounting screws.</p> <p>Follow the instructions in this manual for transportation and installation.</p>
B	 <div data-bbox="614 884 853 1075"> <p>警告 WARNING 警告 AVERTISSEMENT 警告 ADVERTENCIA 警告 ATENÇÃO 경고 OSTOPZHKO</p> <p>当心碰撞 COLLISION HAZARD 当心碰撞 RISQUE DE COLLISION 衝突の危険 PELIGRO DE COLISION 충돌 위험 PERIGO DE MORTE OU FERIMENTOS GRAVES опасность столкновения ОПАСНОСТЬ СТОЛКНОВЕНИЯ</p> </div>	<p>Do not enter the work space when the Manipulator is operating. It is extremely hazardous since the Arm may collide and cause serious safety problems.</p>
C	 <div data-bbox="606 1108 853 1299"> <p>警告 WARNING 警告 AVERTISSEMENT 警告 ADVERTENCIA 警告 ATENÇÃO 경고 OSTOPZHKO</p> <p>当心触电 ELECTRIC SHOCK HAZARD 当心触电 RISQUE DE CHOC ELECTRIQUE 感電の危険 PELIGRO DE DESCARGA ELECTRICA 감전 위험 PERIGO DE CHOQUE ELETRICO опасность поражения электрическим током ОПАСНОСТЬ ПОРАЖЕНИЯ ЭЛЕКТРИЧЕСКИМ ТОКОМ</p> </div>	<p>Do not touch the current-carrying parts inside the Manipulator while the power is ON. It may cause electrical shock.</p>
D	 <div data-bbox="630 1321 853 1512"> <p>警告 WARNING 警告 AVERTISSEMENT 警告 ADVERTENCIA 警告 ATENÇÃO 경고 OSTOPZHKO</p> <p>当心夹手 CRUSH HAZARD 当心夹手 RISQUE D'ECRASEMENT 挟み込みの危険 PELIGRO DE APLASTAMIENTO 손가락 위험 PERIGO DE ESMAGAMENTO опасность разбития ОПАСНОСТЬ РАЗБИТИЯ</p> </div>	<p>You may get your hand or fingers caught when bringing your hand close to moving parts.</p>
E	 <div data-bbox="638 1545 853 1736"> <p>警告 WARNING 警告 AVERTISSEMENT 警告 ADVERTENCIA 警告 ATENÇÃO 경고 OSTOPZHKO</p> <p>当心落下 FALLING HAZARD 当心落下 RISQUE DE CHUTE 落下の危険 PELIGRO DE CAIDAS 낙하 위험 PERIGO DE QUEDA опасность падения ОПАСНОСТЬ ПАДЕНИЯ</p> </div>	<p>When releasing the brakes, be careful of the arm falling due to its own weight.</p>
F	 <div data-bbox="630 1814 853 2004"> <p>注意 CAUTION 注意 ATTENTION 注意 ATENCIÓN 注意 CUIDADO 주의 OSTOPZHKO</p> <p>小心起吊 LIFT WITH CARE 小心起吊 SOULEVEZ AVEC SOIN 小心起吊 LEVANTAR CON CUIDADO 주의해서 들어 올리십시오 LEVANTE COM CUIDADO поднимайте осторожно ПОДНИМАЙТЕ ОСТОРОЖНО</p> </div>	<p>Only authorized personnel should perform sling work and operate a crane and a forklift. If unauthorized personnel perform these operations, it is extremely hazardous and may result in serious bodily injury and/or severe equipment damage to the robot system.</p>

Location	Warning Label	NOTE
G		<p>HOT You can get burned due to high temperature.</p>

Location	Label	NOTE
1	-	<p>The product name, model name, serial number, information which laws and regulations are supported, product specifications, manufacturer, importer, date of manufacture, country of manufacture, etc. are listed. For details, see the label affixed to the product.</p>

Location of Labels:

N6-A850***

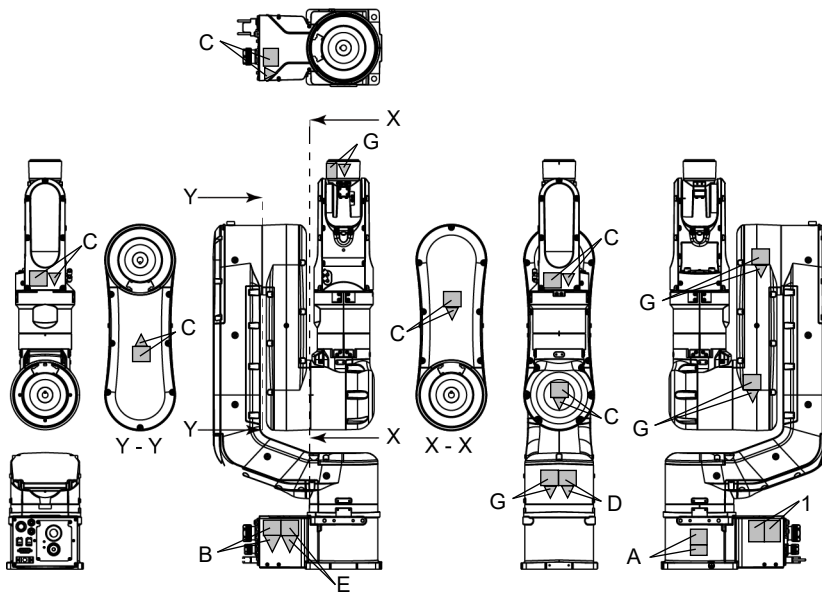

N6-A1000**

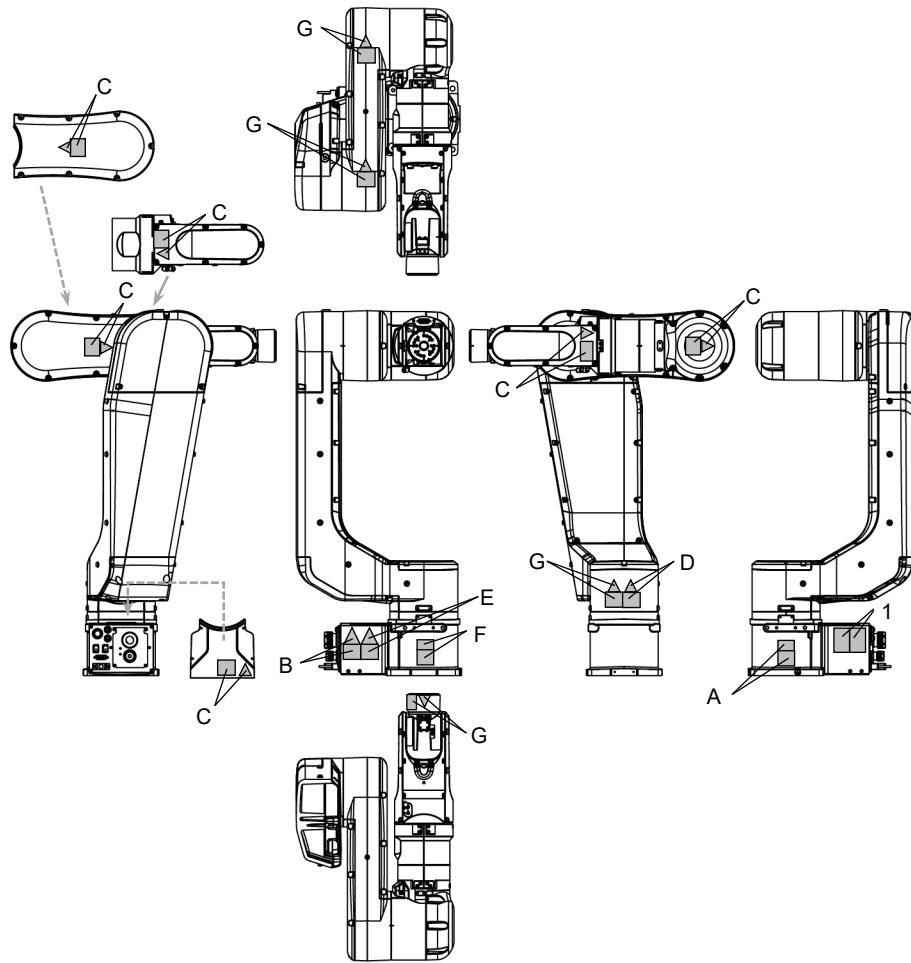

1.9 Response for Emergency or Malfunction

1.9.1 Collision

When the Manipulator collides with a mechanical stopper or peripheral device etc., discontinue use and contact the supplier.

Also, if the Manipulator collides with mechanical stops or peripheral devices, the following problems may occur.

- Reduction of the life and damage of the reduction gear unit
- Position gap at the joints

1.9.2 Getting body caught in Manipulator

When the operator is caught between the Manipulator and a mechanical part such as a base table, press the emergency stop switch to release the brake on the subject arm, and then move the arm by hand.

The Arm without brake (Arm #1):
Move the arm by hand.

The Arm with brake (Arm #2 to #6):
Release the brake on the subject arm, and then move the arm by hand.

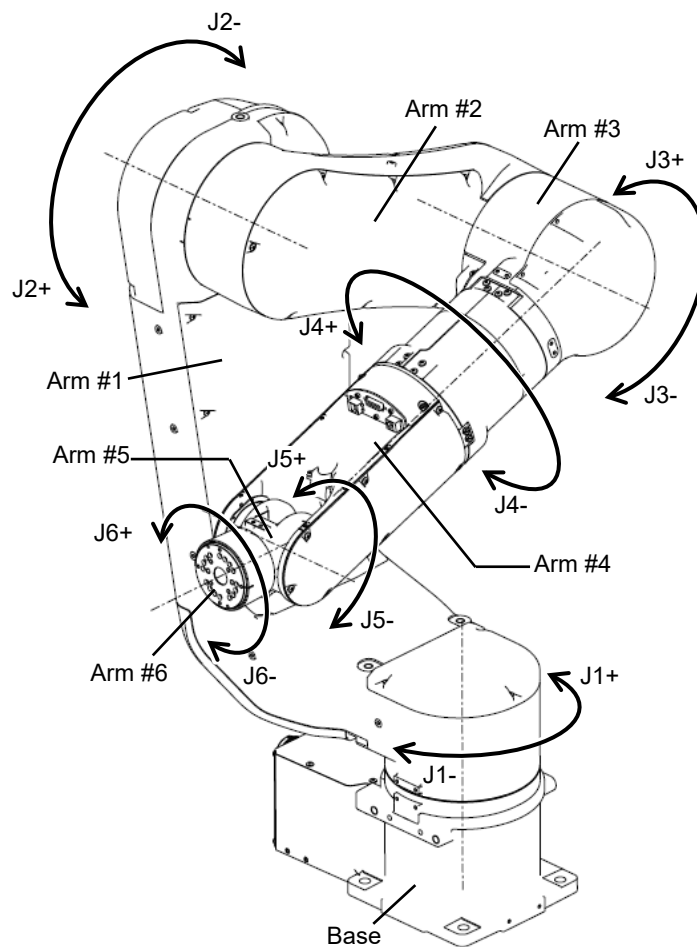

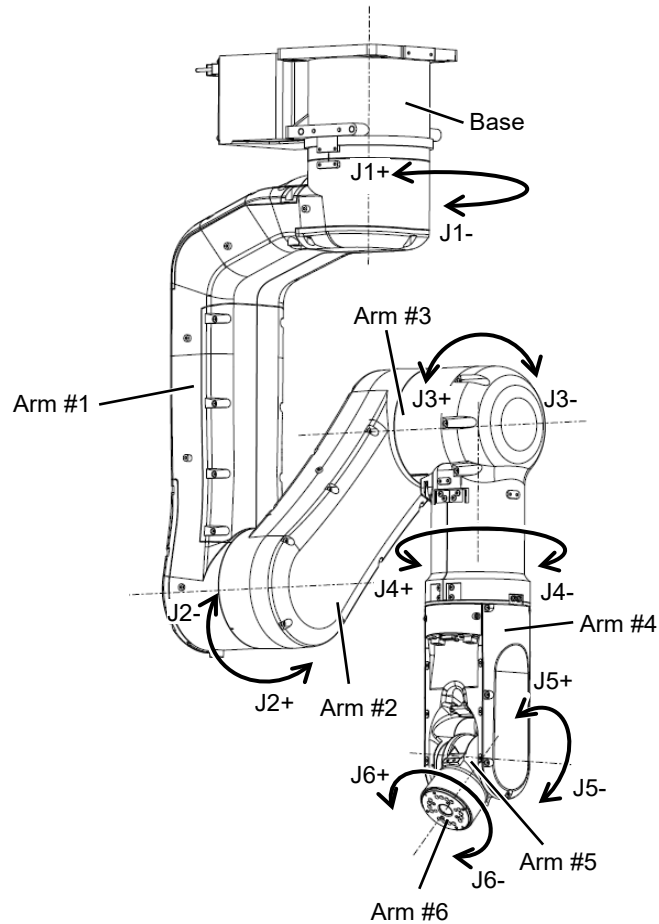

CAUTION

- Normally, release the brake of joints one by one. Take extra care if you need to release the brakes of two or more joints simultaneously. Releasing the brakes of two or more joints simultaneously may cause hands and fingers to be caught and/or equipment damage to or malfunction of the Manipulator as the arms of the Manipulator may move in unexpected directions.
- Be careful of the arm falling when releasing the brake. While the brake is being released, the Manipulator's arm falls by its own weight. The arm falling may cause hands and fingers to be caught and/or may cause equipment damage to or malfunction of the Manipulator.

How to release a brake

Using software:

Epson
RC+

After releasing the Emergency Stop switch, execute the following command in [Command Window].

```
>Reset
```

```
>Brake Off, [ the Arm (#2 to #6) whose brake will be turned OFF]
```

Execute the following command to turn ON the brake again.

```
>Brake On, [ the Arm (#2 to #6) whose brake will be turned ON]
```

Using “Brake release unit (option)”:

Refer to “*6.1 Brake Release Unit*”.

2. Specifications

2.1 Model Number

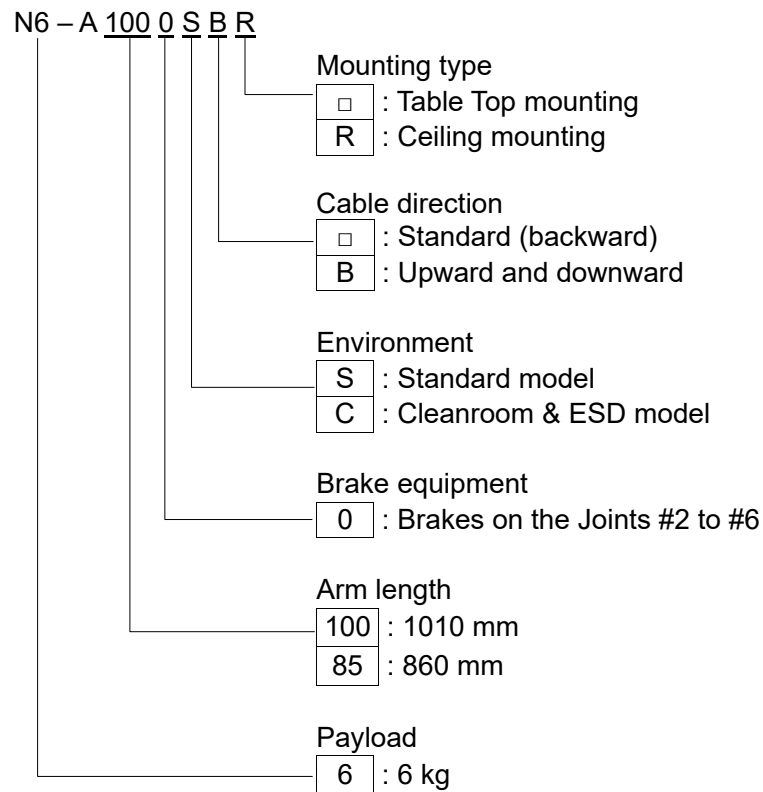

N6-A1000** is set to “Table top mounting” at shipment. To use the Manipulator as “Ceiling mounting”, you need to change the model settings.

N6-A850**R is for “Ceiling mounting” only. “Table Top mounting” is not available.

For details on how to change the model settings, refer to “5.5 Changing the Robot”, and “Epson RC+ User’s Guide Robot Configuration”.

2.2 Part Names

N6-A1000**

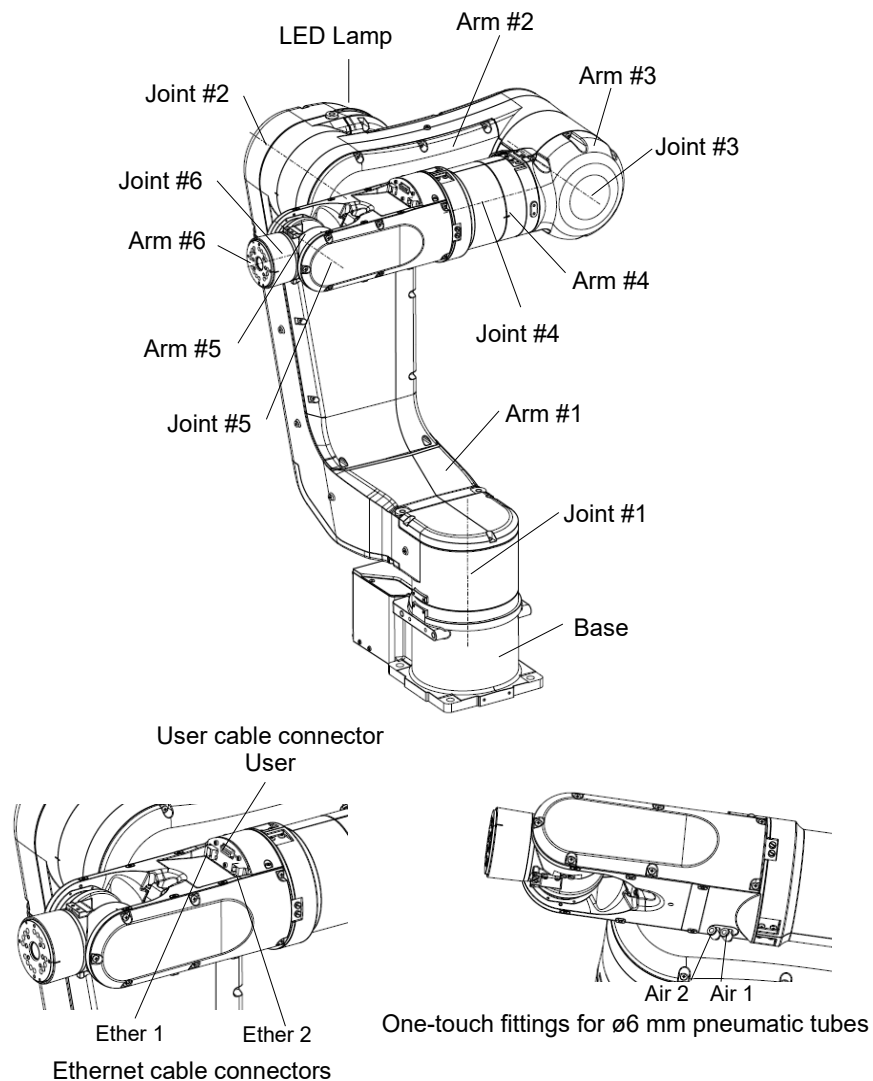

NOTE  When the LED lamp is lighting or the Controller power is on, the current is being applied to the Manipulator. (The LED lamp may not be seen depending on the Manipulator's posture. Be very careful.) Performing any work with the power ON is extremely hazardous and it may result in electric shock and/or improper function of the robot system. Make sure to turn OFF the Controller power before the maintenance work.

N6-A850**R

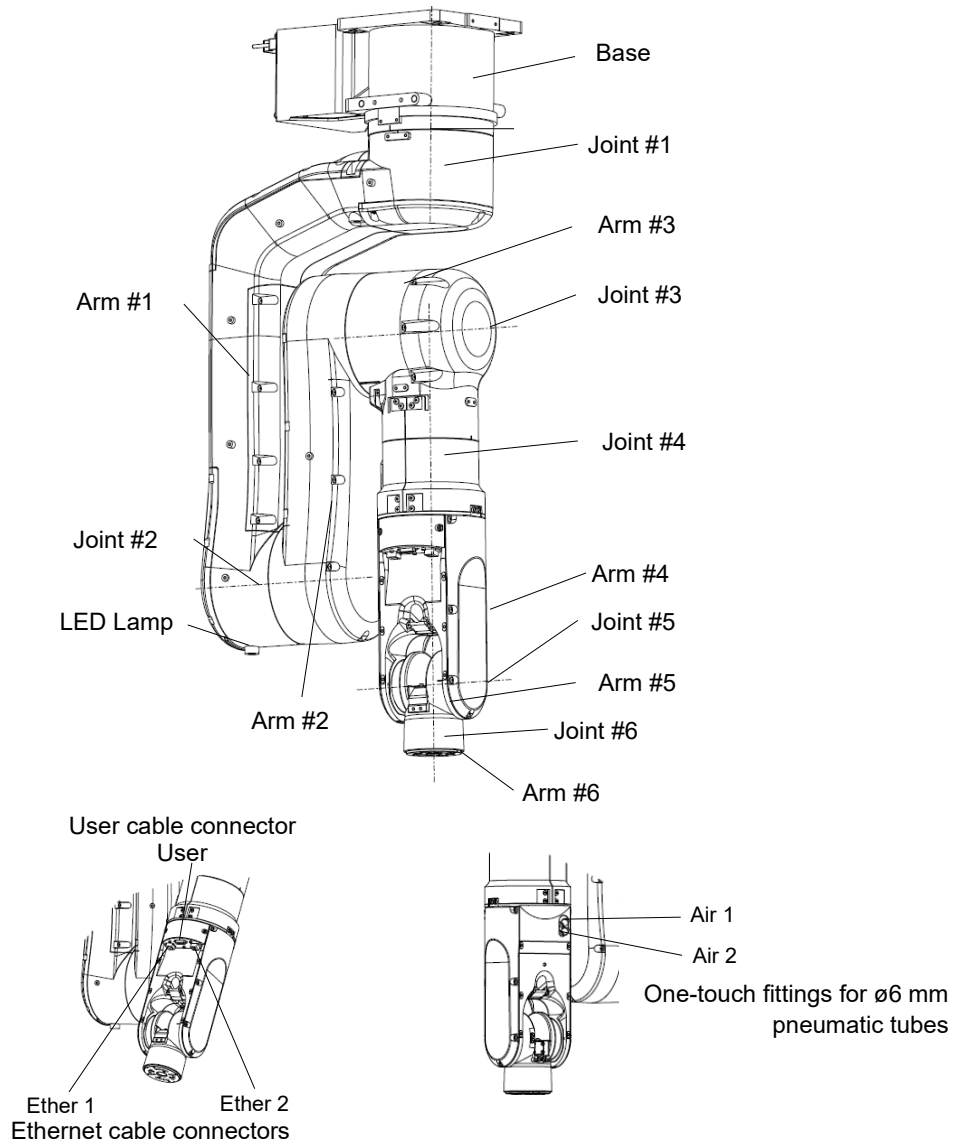

NOTE 

When the LED lamp is lighting or the Controller power is on, current is being applied to the Manipulator. (The LED lamp may not be seen depending on the Manipulator's posture. Be very careful.) Performing any work with the power ON is extremely hazardous and it may result in electric shock and/or improper function of the robot system. Make sure to turn OFF the Controller power before maintenance work.

N6-A1000** / N6-A850**R

Cable direction: Standard (backward)

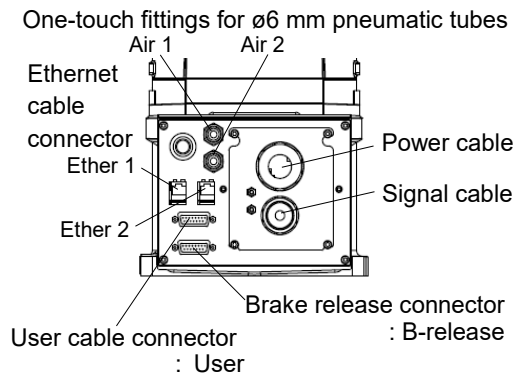

Cable direction: Upward and Downward

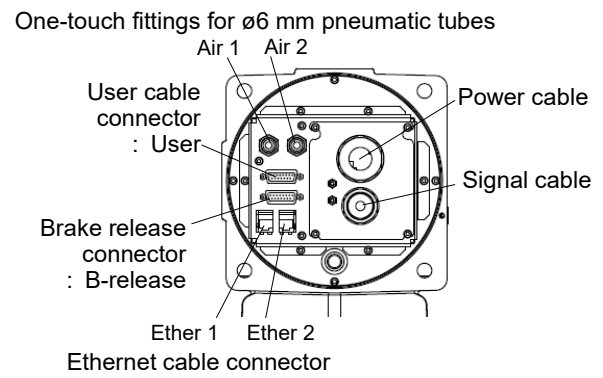

2.3 Outer Dimensions

[Unit: mm]

2.3.1 Basic Orientation

N6-A1000*: Cable direction: Standard (backward)

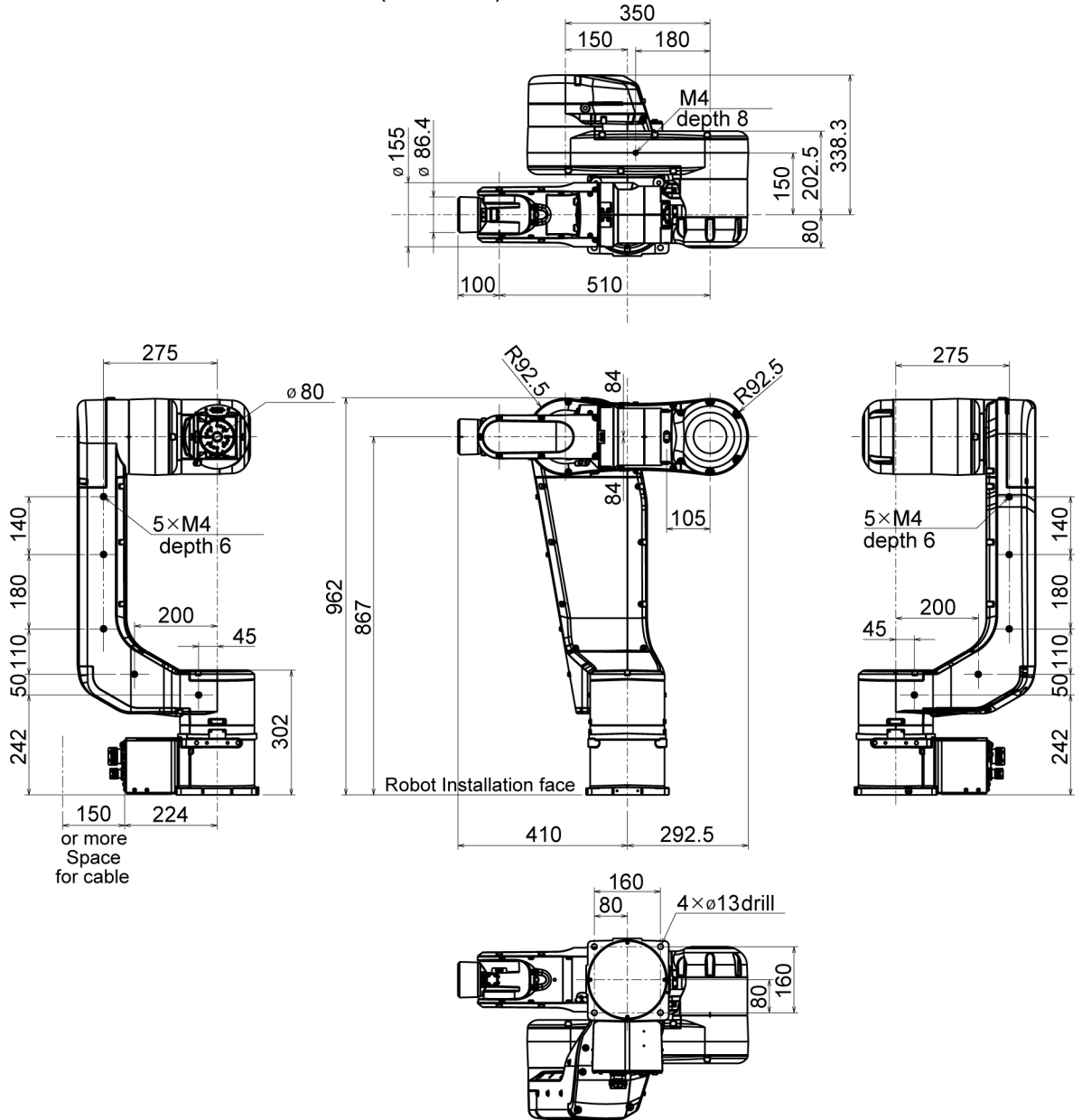

N6-A1000*B: Cable direction: Upward and Downward

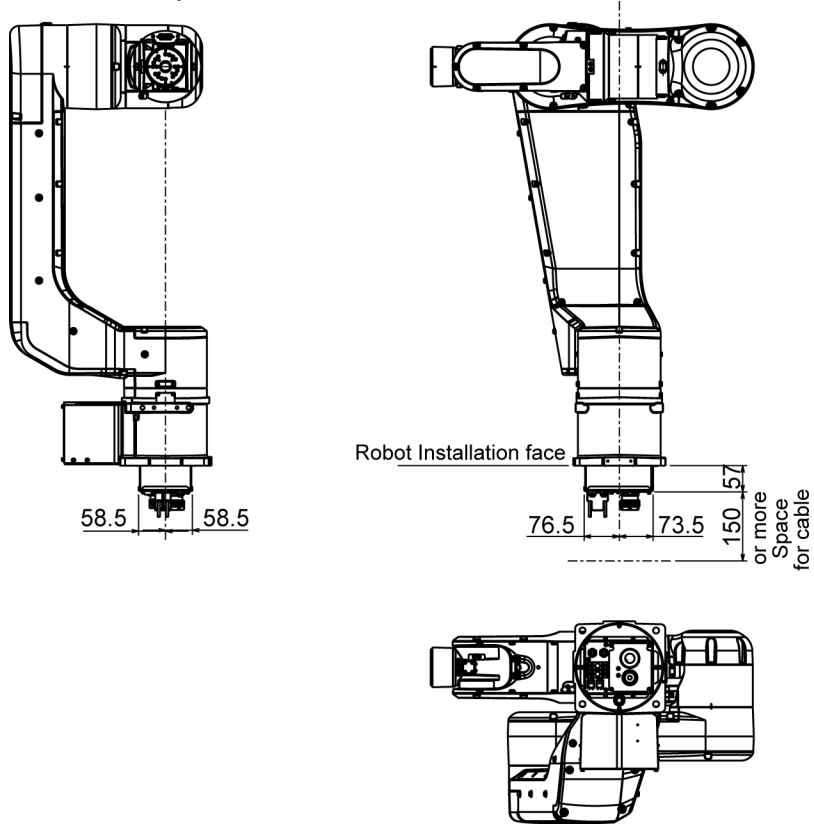

N6-A850*R: Cable direction: Standard (backward)

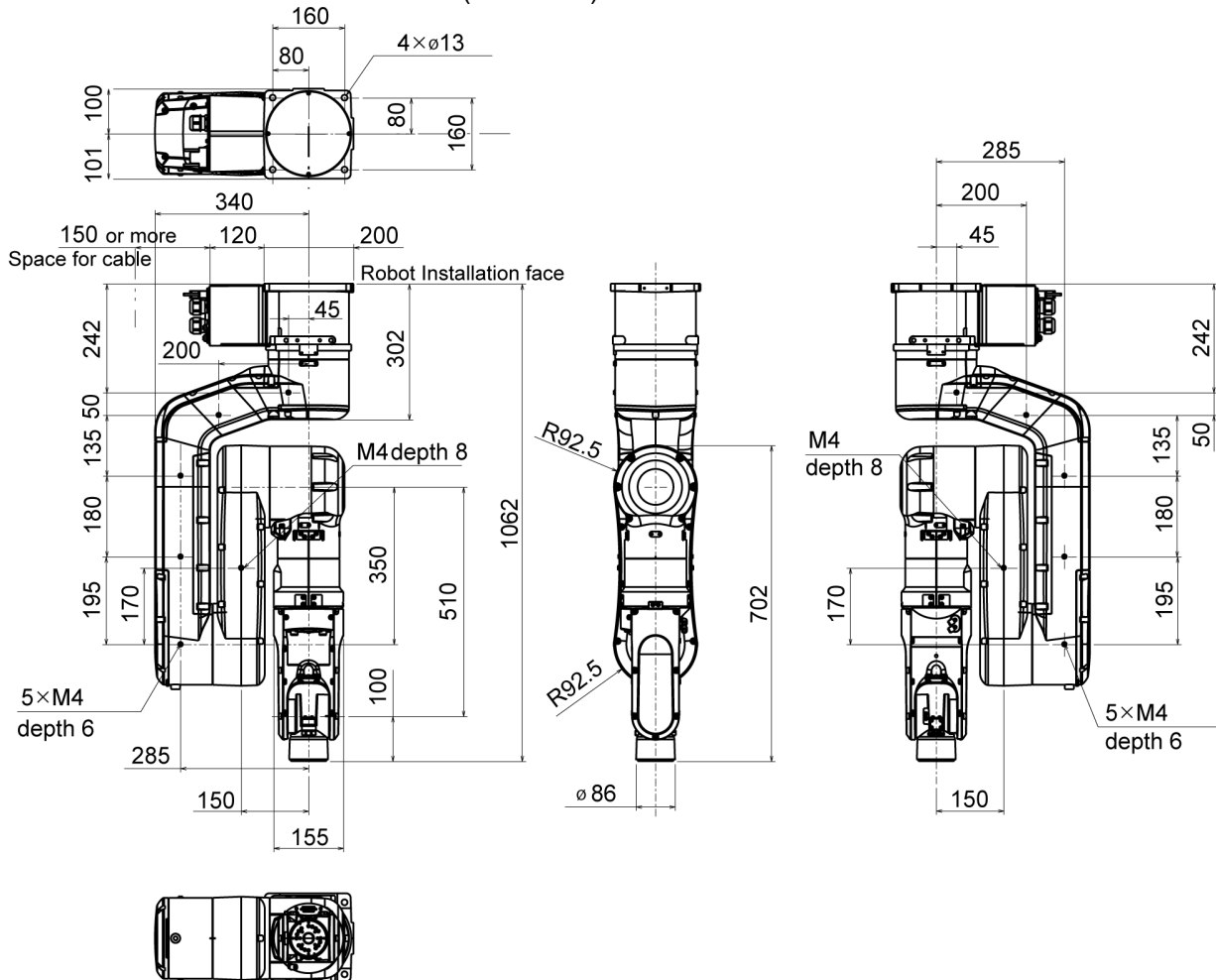

N6-A850*BR: Cable direction: Upward

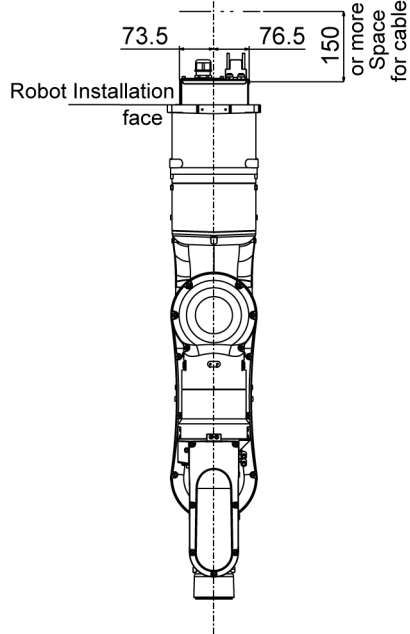
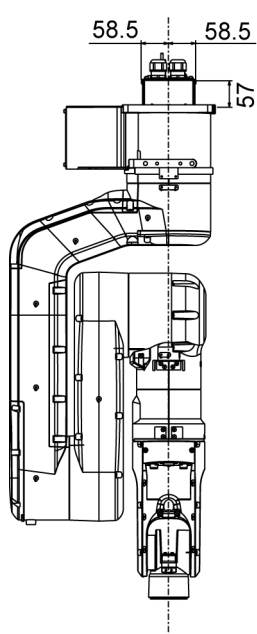
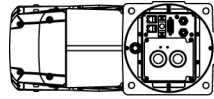

2.3.2 Orientation with the Maximum Arm Length

N6-A1000**

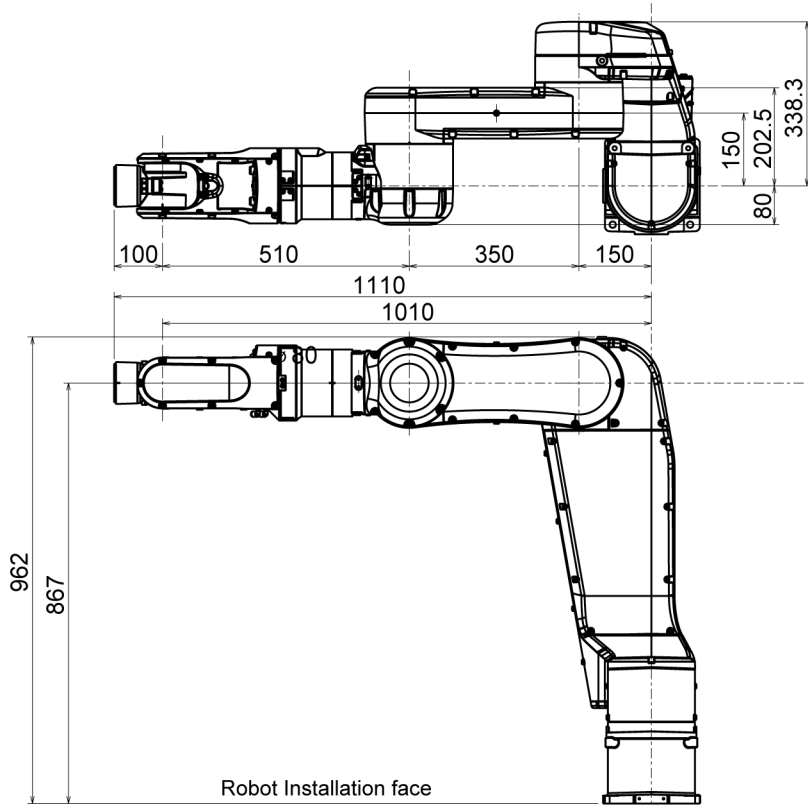

N6-A850**R

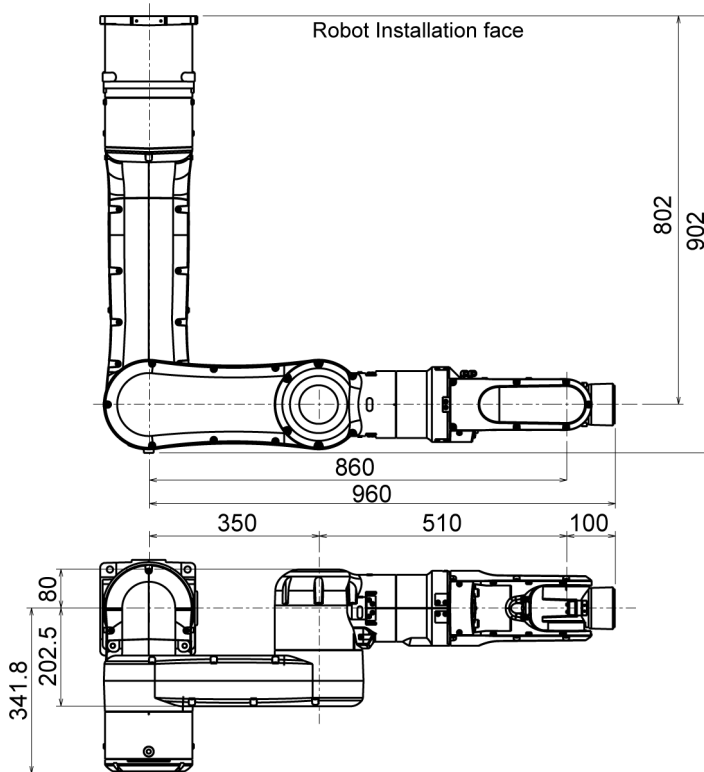

2.4 Standard Motion Range

 CAUTION	<p>■ Pay attention to the arm pose of the basic arms (Arms #1, #2, and #3) when operating the Manipulator. Arm #5 moves keeping a constant angle regardless of the arm pose. Depending on the arm pose of the basic arms, the wrist may collide with the Manipulator. The collision may cause equipment damage to and/or malfunction of the Manipulator.</p>
---	--

N6-A1000**

[Unit: mm]
(deg.= °)

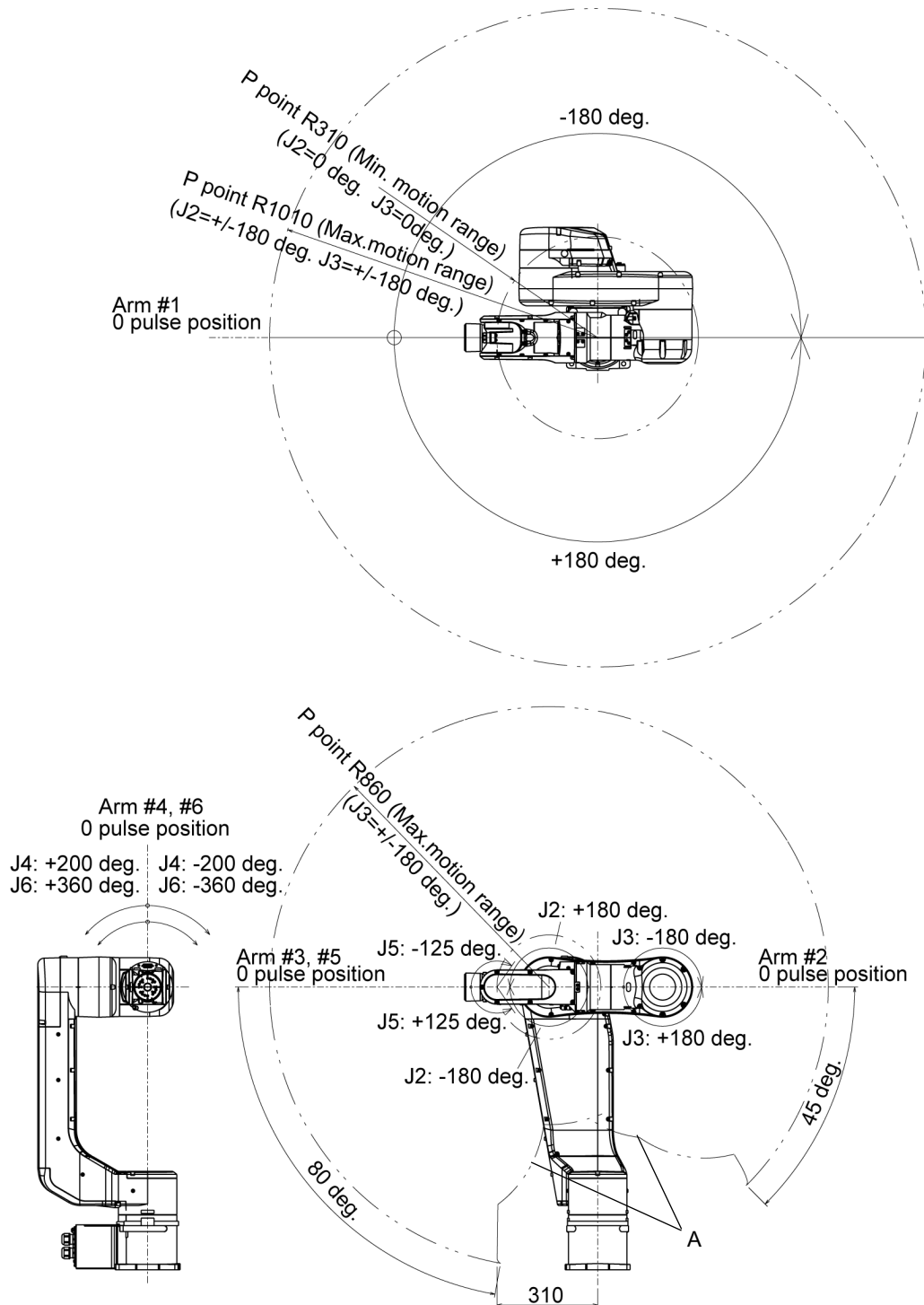

* P point : Intersection of the rotation centers for Joint #4, #5, and #6
 A: No entry range (Reference: 5.2 Coordinate System)

N6-A850**R

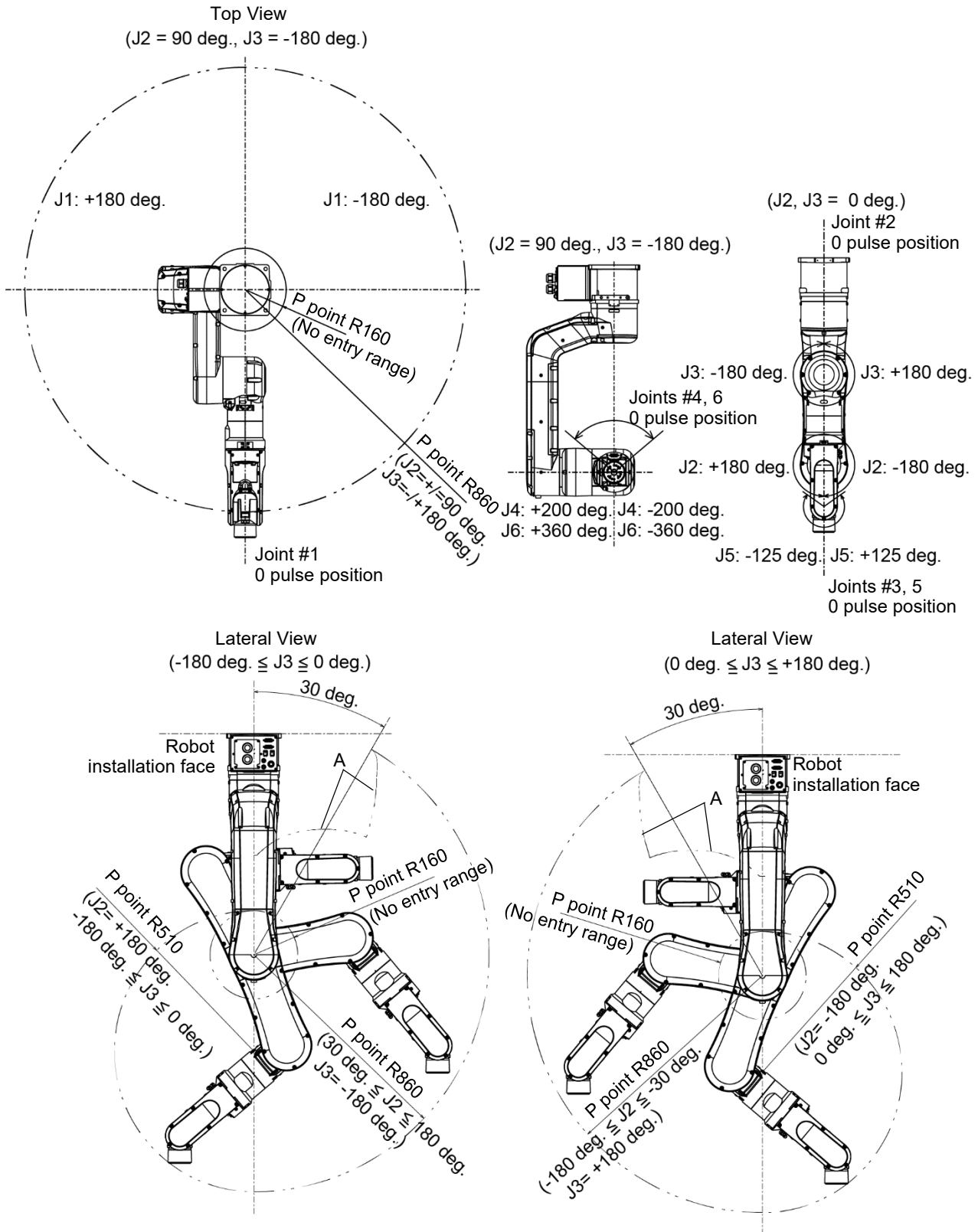

* P point : Intersection of the rotation centers for Joint #4, #5, and #6
A: No entry range (Reference: 5.2 Coordinate System)

2.5 Specifications

2.5.1 Specifications table

For the specifications of each model, refer to “*Appendix A: N6 Specifications*”.

2.5.2 Option

N6 series have the following options. For details, refer to “*6. Options*”.

Brake release unit

The option for moving the arms manually by turning OFF the Electromagnetic brakes.

For EU : Power supply voltage 200 V, short connector included

For US/JP : Power supply voltage 100 V, short connector included

Short connector for the brake release unit

When using the brake release unit with the N6 series Manipulator, it is necessary to connect the short connector to the M/C power cable, or connect the M/C power cable with the Controller. (The brake release unit can be used while the Controller is de-energized state.)

If you are using C3, C4, C8 or N2 series Manipulator and already have the brake release unit, you can use it by connecting the M/C cable with the Controller, or purchasing the short connector separately and connecting it to the M/C power cable.

Camera plate unit

The option for mounting the camera to the Manipulator.

Tool adapter (ISO flange)

The option for mounting the end effector whose dimensions are designed for the ISO flange to the N6 series Manipulators.

User wires

The option for using the internal wiring for the end effector drive.

Standard user connector kit: Standard D-sub 15-pin × 2

2.6 How to Set the Model

The Manipulator model for your system has been set before shipment from the factory.



CAUTION

- When you need to change the setting of the Manipulator model, be sure to set the Manipulator model properly. Improper setting of the Manipulator model may result in abnormal or no operation of the Manipulator and/or cause safety problems.

NOTE



If the custom specifications number (MT***) or (X***) is described on the signature label (S/N label), the Manipulator has custom specifications.

The custom specifications may require a different configuration procedure; check the custom specifications number and contact the supplier of your region when necessary.

The Manipulator model can be set from software.

Refer to the chapter Robot Configuration in the *Epson RC+ User's Guide*.

3. Environment and Installation

Design and installation of robot system shall be performed by personnel who has taken robot system training held by us and suppliers and should conform to all national and local codes.

3.1 Environmental Conditions

A suitable environment is essential for the robot system to function properly and safely. Be sure to install the robot system in an environment that meets the following conditions:

Item	Conditions
Ambient temperature* ¹	5 to 40 °C
Ambient relative humidity	20% to 80% (no condensation)
Fast transient burst noise	1 kV or less (Signal wire)
Electrostatic noise	4 kV or less
Altitude	1000 m or lower
Environment	<ul style="list-style-type: none"> - Install indoors - Keep away from direct sunlight - Keep away from dust, oily smoke, salinity, metal powder or other contaminants - Keep away from flammable or corrosive solvents and gases - Keep away from water - Keep away from shock or vibration - Keep away from sources of electric noise - Keep away from explosive area - Keep away from a large quantity of radiation

*1 The ambient temperature conditions are for the Manipulators only. For the Controller which the Manipulator is connected to, refer to the Controller manual.

When the product is used in a low temperature environment around the minimum temperature of the product specification, or when the product is suspended for a long time on holidays or at night, a collision detection error may occur due to the large resistance of the drive unit immediately after the start of operation. In such a case, it is recommended to warm up for about 10 minutes.



When using the Manipulators in inadequate environments that do not meet the above conditions, please contact the supplier of your region.

Special Environmental Conditions

The surface of the Manipulator has general oil resistance. However, if your requirements specify that the Manipulator must withstand certain kinds of oil, please contact the supplier of your region.

Rapid change in temperature and humidity can cause condensation inside the Manipulator. If your requirements specify that the Manipulator handles food, please contact the supplier of your region to check whether the Manipulator will damage the food or not.

The Manipulator cannot be used in corrosive environments where acid or alkaline is used. In a salty environment where the rust is likely to gather, the Manipulator is susceptible to rust.

 <p>WARNING</p>	<ul style="list-style-type: none">■ Use an earth leakage breaker on the AC power cable of the Controller to avoid the electric shock and circuit breakdown. Prepare the earth leakage breaker that pertains the Controller you are using. For details, refer to the Controller manual.
--	--

 <p>CAUTION</p>	<ul style="list-style-type: none">■ When cleaning the Manipulator, do not rub it strongly with alcohol or benzene. It may lose luster on the coated face.
--	---

3.2 Unpacking, Transportation, and Relocation

Using a cart or similar equipment, transport the Manipulator in the same conditions as it was delivered. Observe the following when unpacking the Manipulator.

Unpacking, transportation, and relocation shall be performed by personnel who has taken robot system training held by us and suppliers and should conform to all national and local codes.

 WARNING	<ul style="list-style-type: none"> Only authorized personnel should perform sling work and operate a crane or a forklift. When these operations are performed by unauthorized personnel, it is extremely hazardous and may result in serious bodily injury and/or severe equipment damage to the robot system. Stabilize the Manipulator with your hands when hoisting it. Unstable hoisting is extremely hazardous and may result in serious bodily injury and/or severe equipment damage to the robot system as the fall of the Manipulator.
---	--

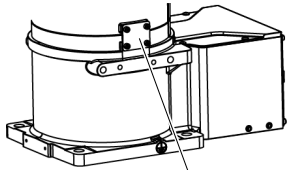
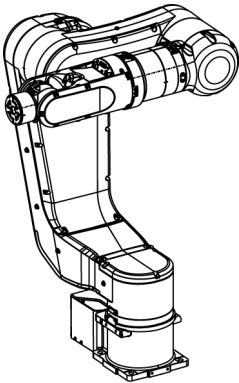
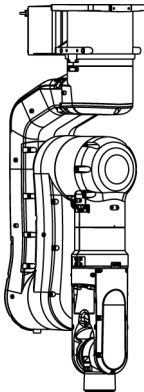
 CAUTION	<ul style="list-style-type: none"> When removing the anchor bolts, support the Manipulator to prevent falling. Removing the anchor bolts without supporting the Manipulator may get hands, fingers, or feet caught as the Manipulator may fall. <p>The base and the Arm #1 are fixed by the fixing jig for transportation.</p> <p>Make sure to remove the fixing jig before the robot operates.</p>	 Fixing jig for transportation
	<ul style="list-style-type: none"> To carry the Manipulator, be sure to have at least 2 people to hold the bottom of the base or the Arm by hand. When holding the base installation face by hand, be careful not to cause your hands and fingers caught. 	
	<p>N6-A1000**</p>  Weight: 69 kg: 152 lbs.	<p>N6-A850**R</p>  Weight: 64 kg: 141 lbs.
	<ul style="list-style-type: none"> Avoid excessive vibration or shock during Manipulator transporting. Excessive vibration or shock may cause equipment damage to and/or malfunction of the Manipulator. 	

Be sure to transport and store the robot system in environments that meet the following conditions:

Item	Conditions
Ambient temperature	0 to 45 °C
Ambient relative humidity	10 % to 80 % (no condensation)

During unpacking and relocation, avoid applying external force to the arms and motors of the Manipulator.

When transporting the Manipulator for a long distance, secure it to the delivery equipment so that the Manipulator cannot fall. If necessary, pack the Manipulator in the same way as it was delivered.

When condensation occurs on the Manipulator during transport or storage, turn ON the power only after the condensation dries.

When using the Manipulator for the robot system again after long-term storage, perform a test run to verify that the Manipulator works properly. Then, operate the Manipulator thoroughly.

Relocating

Follow the procedures described below when relocating the Manipulator.



The Joint #1 is not equipped with the brake. When installing the Manipulator, be careful not to rotate the Joint #1.

The cable may break when exceeding Max. motion range. Be careful to operate.

- (1) Turn ON the Controller.
- (2) Change the Manipulator orientation so that it is easy to support when removing it.
Recommended posture: Basic orientation.

```

Epson RC+ Command
> Pulse 0, 0, 0, 0, 0, 0, 0
    
```

N6-A1000**

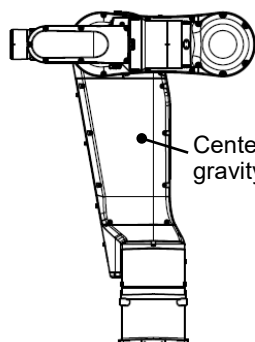

Center of gravity

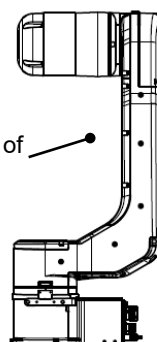

N6-A850**R

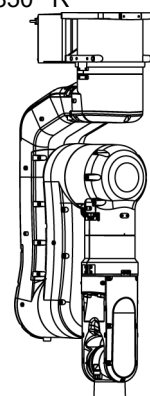

- (3) Turn OFF the power for all devices and disconnect the power cable connector and signal cable connector from the Controller.

- (4) Unscrew the anchor bolts. Then, remove the Manipulator from the base table.



NOTE Manipulator does not stand by itself. Be careful or it will fall over.

When the Manipulator is mounted on the ceiling, make sure it is secured correctly or it may fall.

- (5) Secure the Manipulator to the delivery equipment or have at least 2 people to carry the Manipulator.
- (6) After installing the Manipulator, turn ON the Controller.

If you use the eyebolt to hang the robot for transportation, follow the steps below.

- (1) Turn ON the Controller.
- (2) Change the Manipulator orientation so that it is easy to support when removing it.

Recommended posture:

N6-A1000**: Joint #2 -65°, Joint #3 -25°

N6-A850**R: Basic orientation

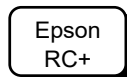

Command

N6-A1000**: > Go AglToPls (0, -65, -25, 0, 0, 0)

N6-A850**R: > Go AglToPls (0, 0, 0, 0, 0, 0)

N6-A1000**

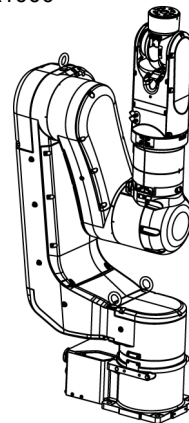

N6-A850**R

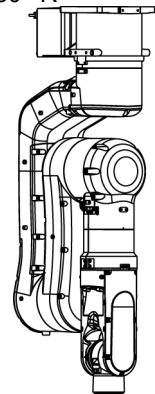

- (3) Turn OFF the power for all devices and disconnect the power cable connector and signal cable connector from the Controller.

- (4) Unscrew the anchor bolts. Then, remove the Manipulator from the base table.



NOTE Manipulator does not stand by itself. Be careful or it will fall over.

When the Manipulator is mounted on the ceiling, make sure it is secured correctly or it may fall.

- (5) Secure the Manipulator to the delivery equipment or have at least 2 people to carry the Manipulator.
- (6) After installing the Manipulator, turn ON the Controller.
- (7) Return the Manipulator to the basic orientation.

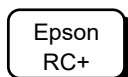

Command

> Pulse 0, 0, 0, 0, 0, 0

Using Eyebolt

Before carrying the Manipulator, make sure to check that the eyebolts are securely fastened.

After transporting the Manipulator, remove the eyebolts and keep them for future use.

The eyebolts (accessory, 3 pcs) and wire must be strong enough to withstand the weight (See the figures below).

If you use the eyebolts to lift up the Manipulator, make sure to put hands on it to keep the balance. The Manipulator may fall if the balance is lost and this is extremely hazardous.

To prevent damage on the covers and arms, it is recommended to protect the contacting parts of the wire and arm with a cloth. Be very careful not to damage the covers since they are made of plastic.

N6-A1000**

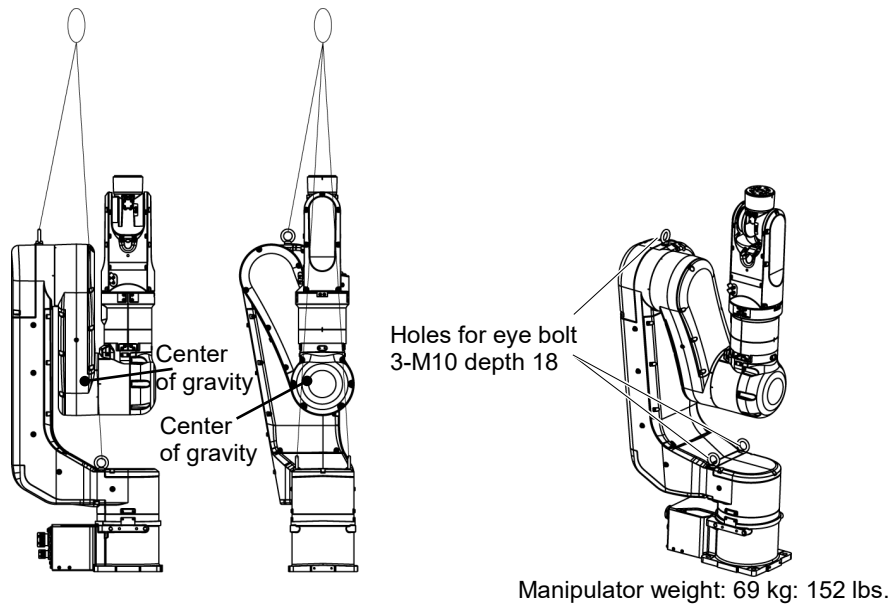

N6-A850**R

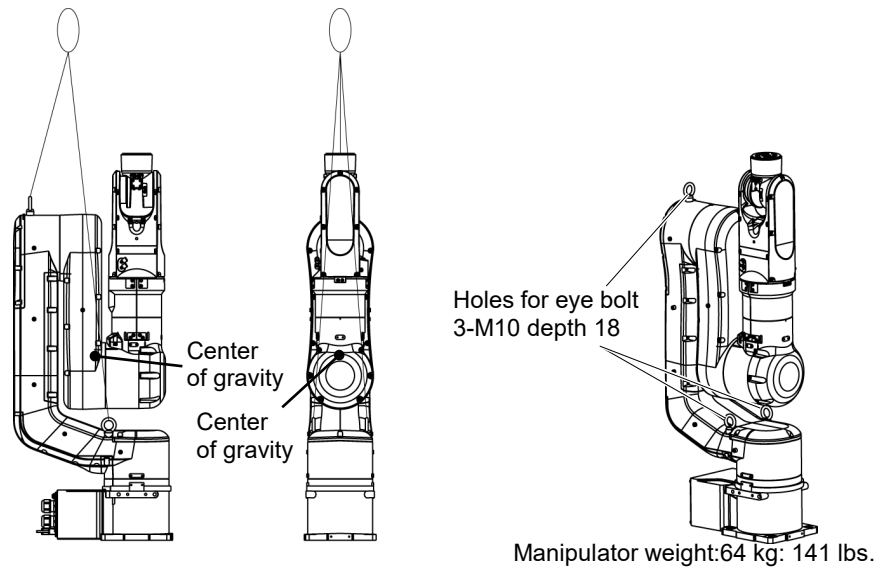

 CAUTION	<p>■ Remove the eyebolts from the Manipulator after transportation/relocation is completed. If the Manipulator is operated with the eyebolts left on it, the arm may collide with the eyebolts and it may cause equipment damage to and/or malfunction of the Manipulator.</p>
---	--

3.3 Mounting Dimensions

3.3.1 Mounting Area

Be sure to have the following space available in addition to the space for mounting the Manipulator, Controller, and peripheral equipment.

- Space for teaching points
- Space for maintenance and inspections (for installing jigs)
- Space for cables



When installing the cable, be sure to maintain sufficient distance from obstacles. For the minimum bend radius of the MC cable, refer to "Appendix A: N6 Specifications". In addition, leave enough space for other cables so that they are not bent forcibly.

3.3.2 Mounting dimensions

[Unit: mm]

N6-A1000**: Cable direction: Standard (backward)

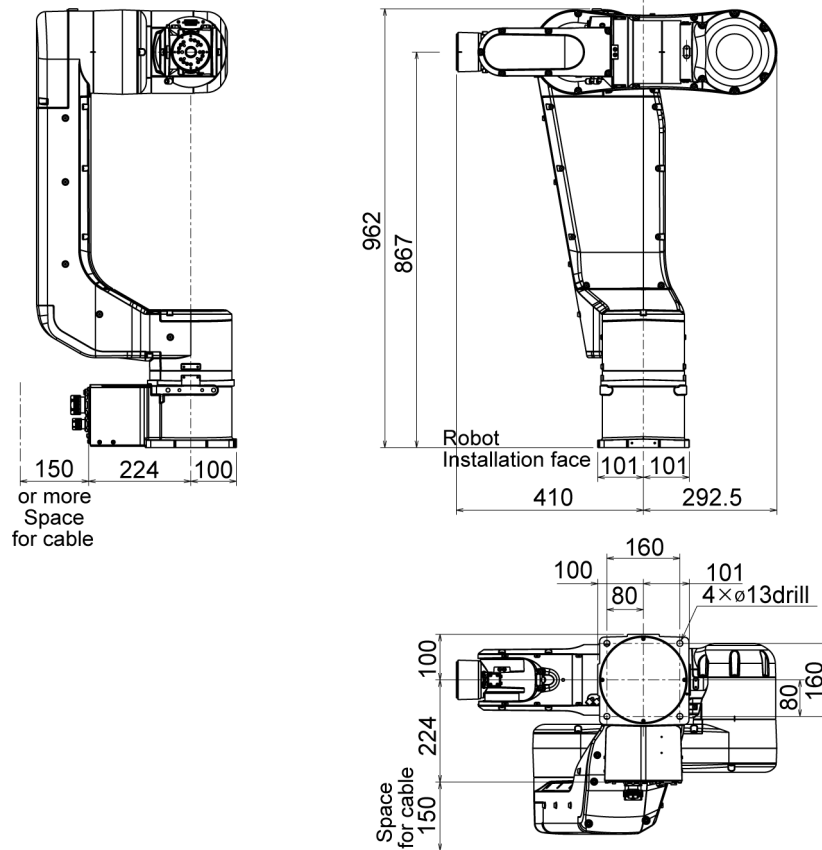

N6-A1000**: Cable direction: Upward and Downward

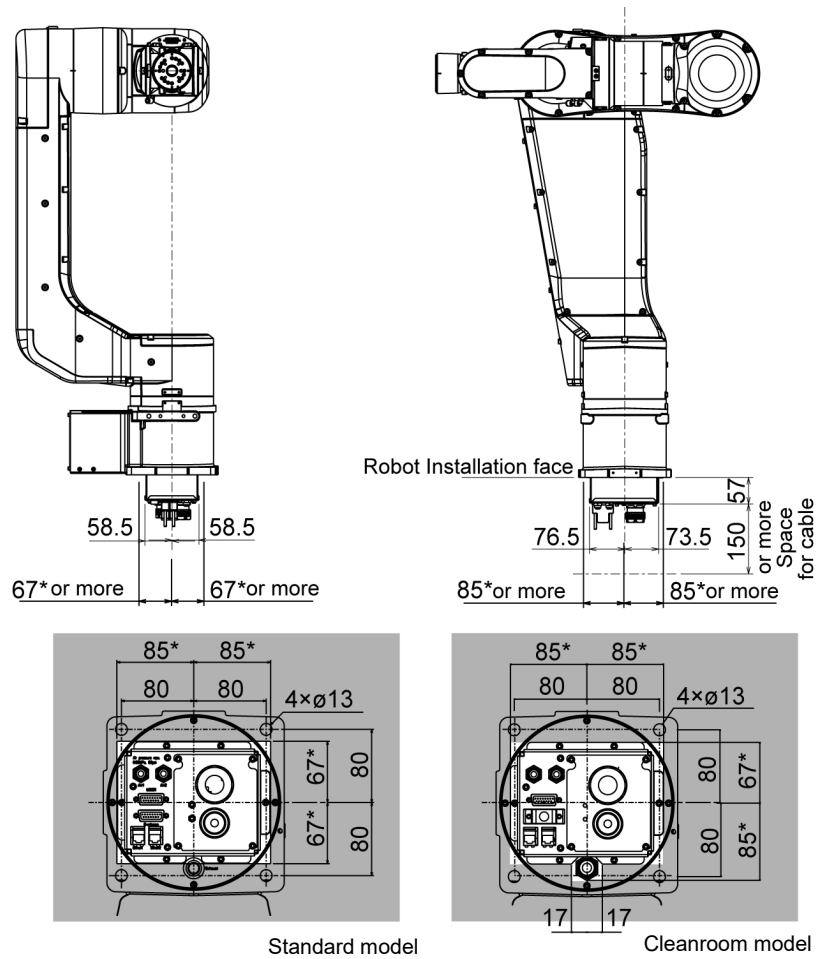

*: Example of space for Manipulator base for "Cable direction: Upward and Downward": Design the base table as shown above considering not interfering with the positioning holes and the installation holes.

N6-A850**R:

Cable direction: Standard (backward)

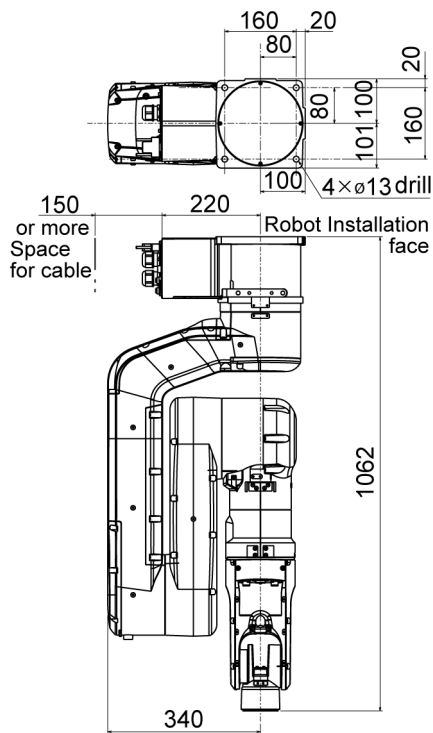

Cable direction: Upward

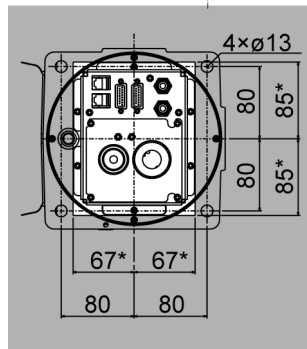
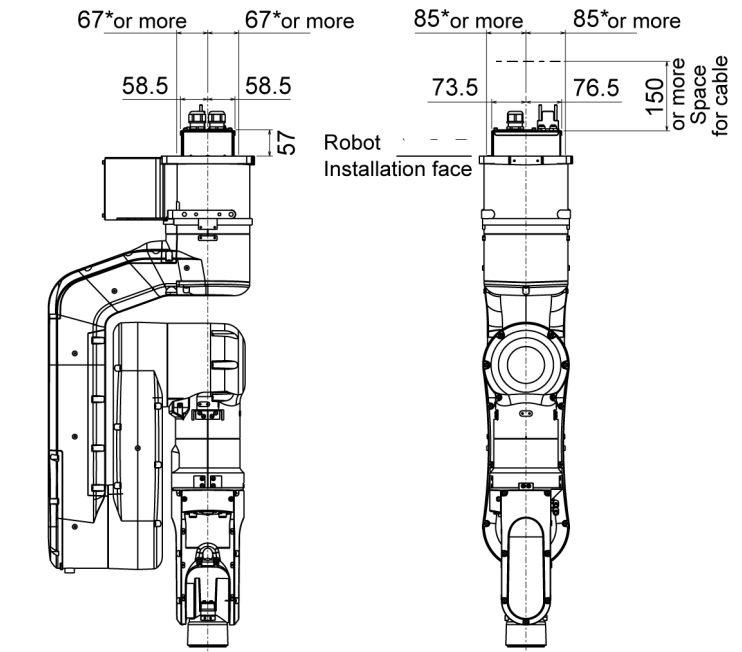

Standard model

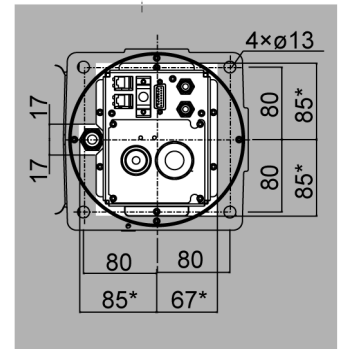

Cleanroom model

*: Example of space for Manipulator base for “Cable direction: Upward”:
Design the base table as shown above considering not interfering with the positioning holes and the installation holes.

3.3.3 Motion range

The following figures are the cases when the length of the end effector is 100 mm. Match the ranges with the actual end effector length. If the camera or the electromagnetic valve attached on the Arm is large, define the max motion ranges by considering the area where these tools may reach.

When operating in narrow space with the basic orientation, make sure to consider the radius of the arm rotation as shown the figure below. The Manipulator must be installed to avoid interference with peripherals during operation.

N6-A1000**: Maximum motion range

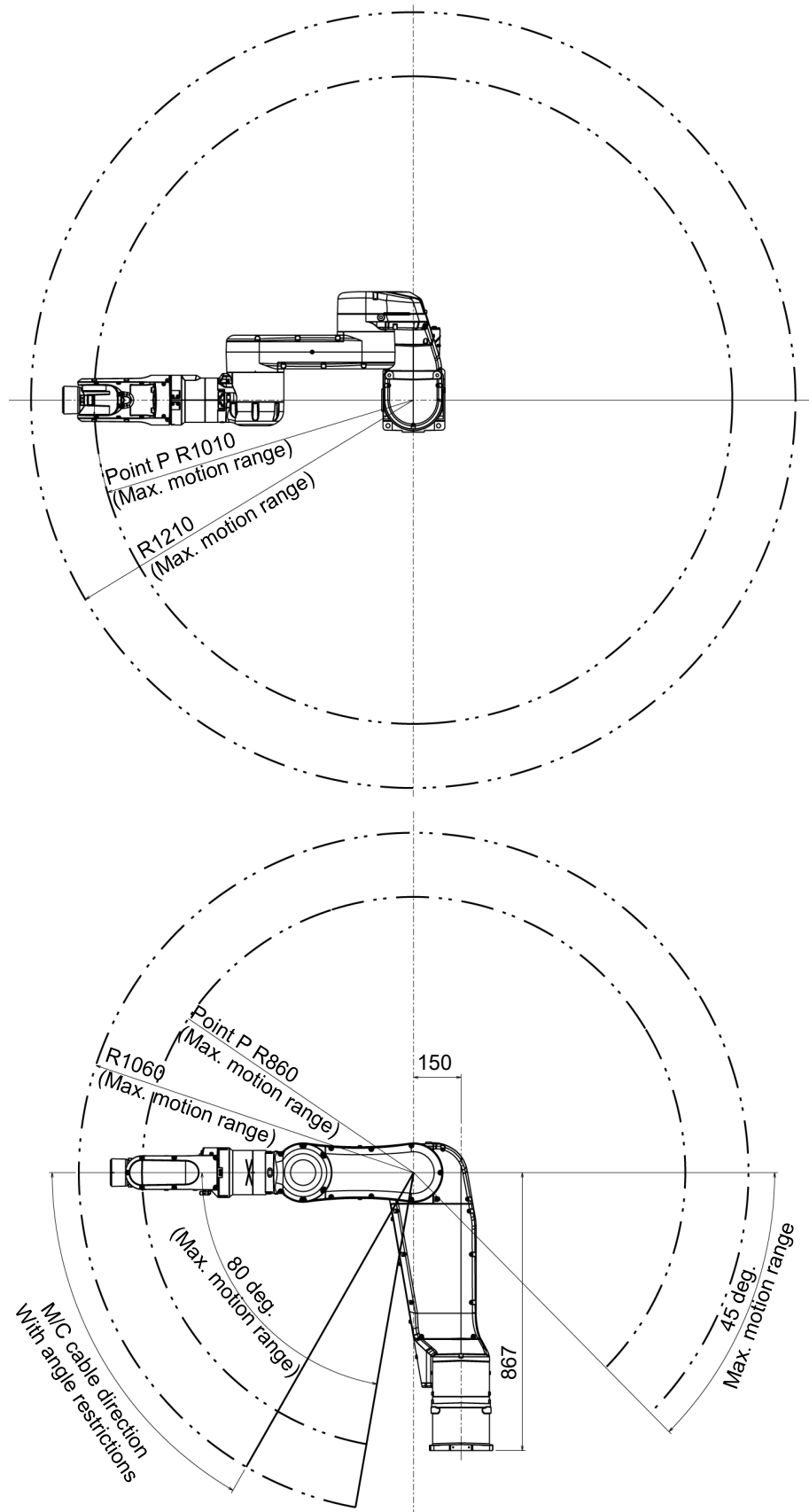

N6-A1000**: Radius of arm rotation (Basic orientation)

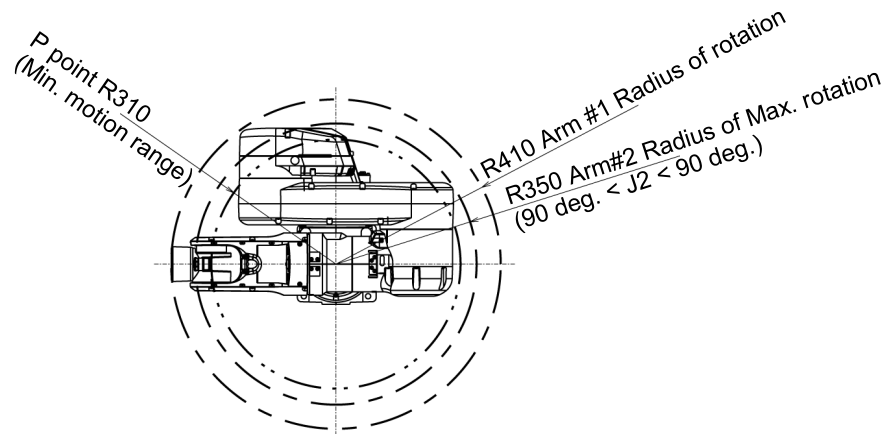

Motion range (CP motion)

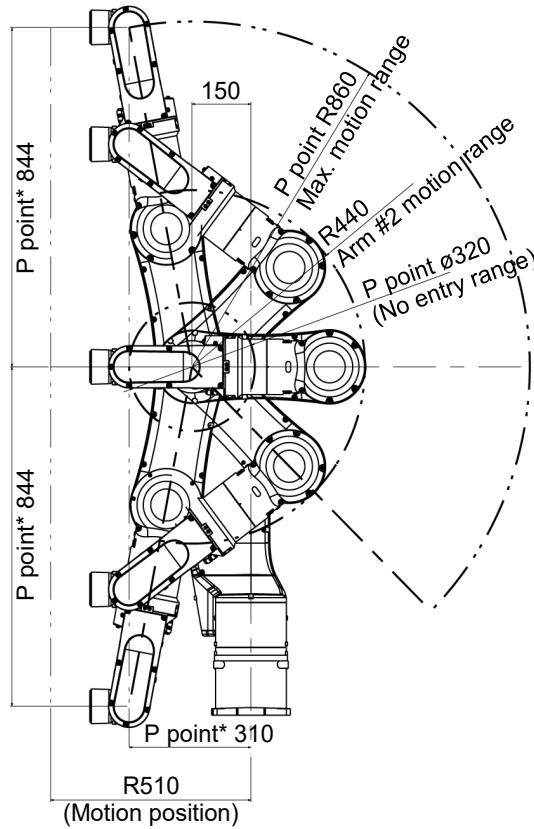

* When the P point is 310mm apart from the center, upward and downward distance in CP motion will be the maximum.

N6-A850**R: Maximum motion range

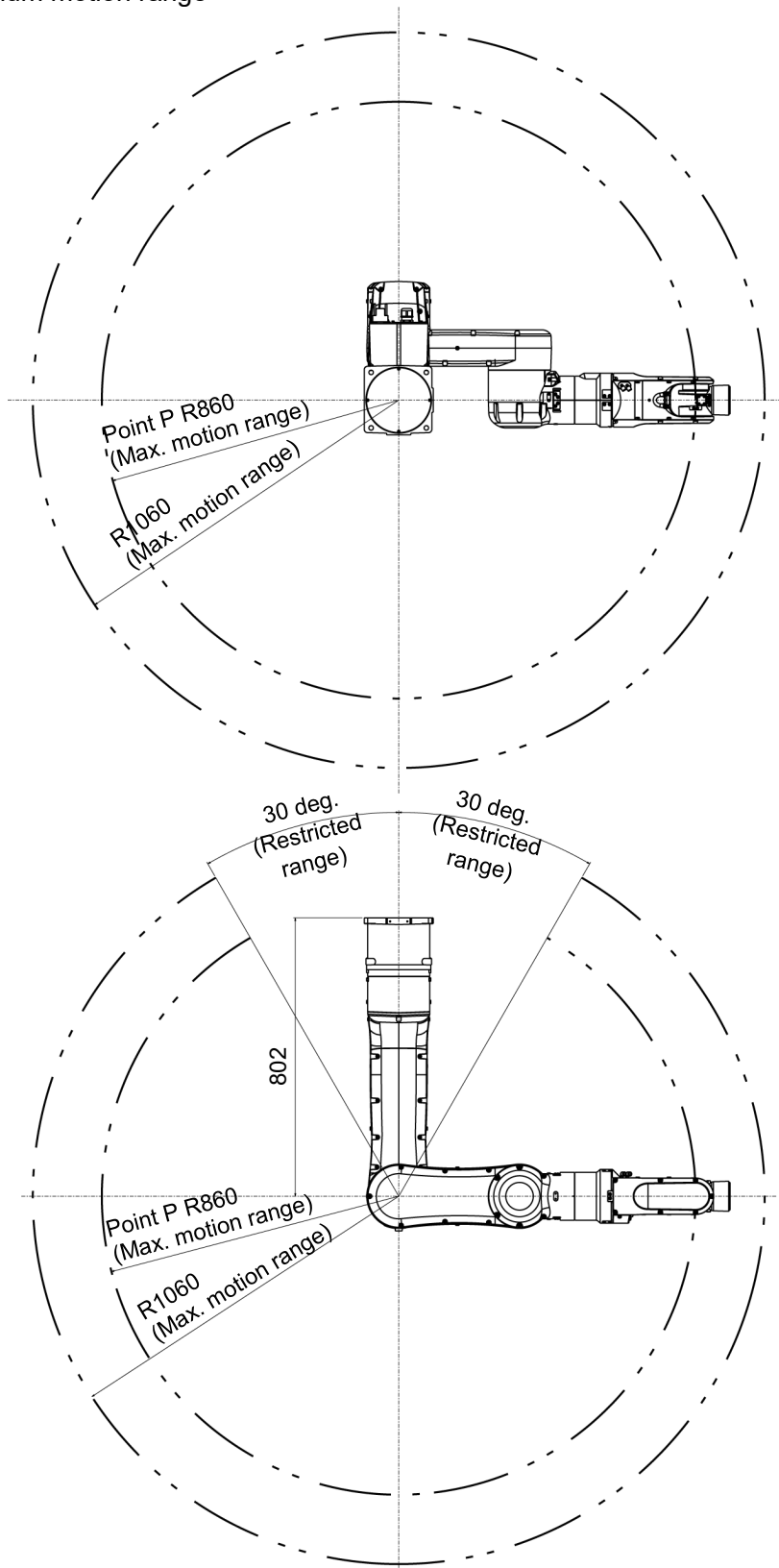

3.4 Installation

The installation shall be made by personnel who has taken robot system training held by us and suppliers and should conform to all national and local codes.

 WARNING	<ul style="list-style-type: none"> ■ To ensure safety, a safeguard must be installed for the robot system. For details on the safeguard, refer to the <i>Installation and Design Precautions</i> in the <i>Safety</i> chapter of the Epson RC+ User's Guide. ■ Anchor the Manipulator before turning ON the power to or operating the Manipulator. Turning ON the power to or operating the Manipulator that is not anchored is extremely hazardous and may result in serious bodily injury and/or severe equipment damage to the robot system as the Manipulator may fall down. ■ Before installing and operating the Manipulator, make sure that all parts of the Manipulator are in place and have no external defects. Missing or defective parts may cause improper operation of the Manipulator. Improper operation of the Manipulator is extremely hazardous and may result in serious bodily injury and/or severe equipment damage to the robot system.
---	--

 CAUTION	<ul style="list-style-type: none"> ■ The Manipulator must be installed to avoid interference with buildings, structures, utilities, other machines and equipment that may create a trapping hazard or pinch points. ■ Oscillation (resonance) may occur during operation depending on rigidity of the installation table. If the oscillation occurs, improve rigidity of the table or change the speed or acceleration and deceleration settings.
--	---

Mounting bolt

For the dimensions, refer to “3.3 Mounting Dimensions”.

There are four threaded holes for the Manipulator base.

Use M12 mounting bolts conforming to the strength of ISO898-1 property class 10.9 or 12.9.

Tightening torque:
100 N·m (1020 kgf·cm)

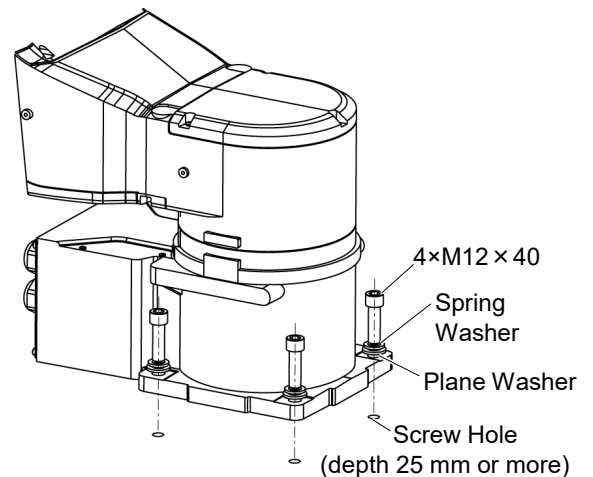

After installing the robot, make sure to remove the fixing jig that fix the base and the Arm #1.

Hexagon socket head screws: 4-M4x8

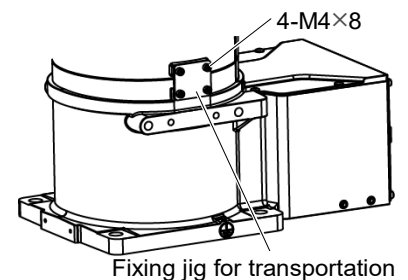

Ceiling mounting

To mount the Manipulator on the ceiling, install the eyebolts on the tap hole for transportation and lift up the Manipulator by the wire.

Check that the eyebolts are securely fastened before carrying the Manipulator. After transporting the Manipulator, remove the eyebolts and keep them for future use.

The eyebolts (3 eyebolts) and wire must be strong enough to withstand the Manipulator weight (See the figures below).

Only authorized personnel should perform sling work and operate a crane and a forklift. When these operations are performed by unauthorized personnel, it is extremely hazardous and may result in serious bodily injury and/or severe equipment damage to the robot system.

Tap hole position for transportation

N6-A1000**

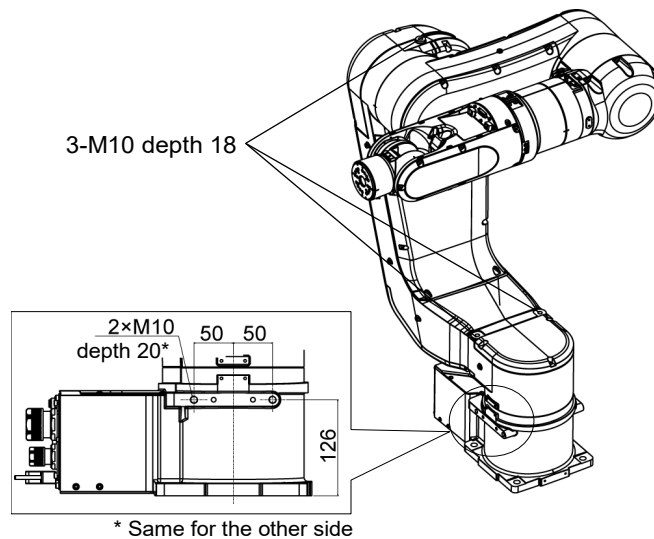

N6-A850**R

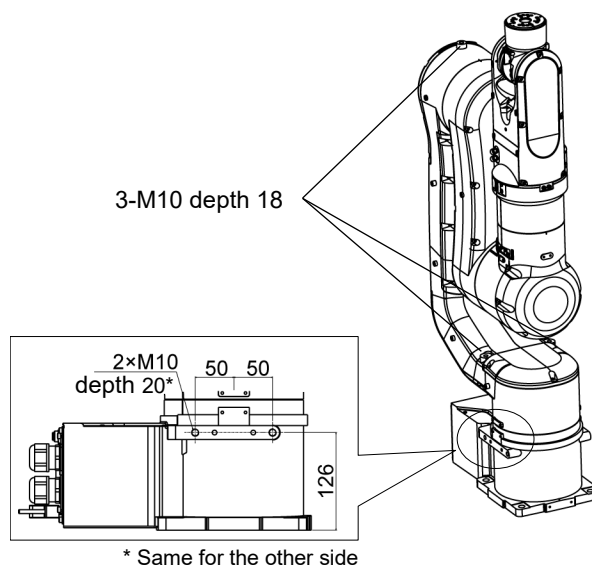

Cleanroom model

When using the Manipulator in the cleanroom, follow the steps below before the installation.

- (1) Unpack the Manipulator outside of the cleanroom.
- (2) Secure the Manipulator to delivery equipment such as a pallet with bolts so that the Manipulator does not fall over.
- (3) Wipe off the dust on the Manipulator with a little alcohol or distilled water on a lint-free cloth.
- (4) Transport the Manipulator to the cleanroom.
- (5) Secure the Manipulator to the base table.

When operating the Manipulator after installing it, exhaust from the exhaust port is 60L/min.

Cable direction: Standard (backward)

Cleanroom model: Exhaust port
(One-touch fittings for
ø10 mm pneumatic tubes)

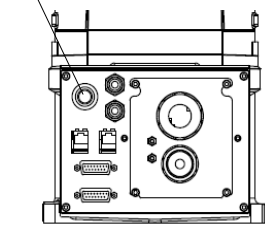

Cable direction: Upward and Downward

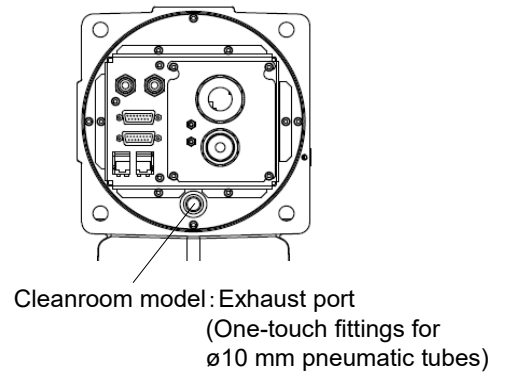

3.5 Base Table

A base table for anchoring the Manipulator is not supplied. Please make or obtain the base table for your Manipulator. The shape and size of the base table differ depending on the intended use of the robot system. The following is the basic requirements of Manipulator table for your reference.

The base table must not only be able to bear the weight of the Manipulator but also be able to withstand the dynamic movement of the Manipulator when it operates at maximum acceleration/deceleration. Ensure that there is enough strength on the base table by attaching reinforcing materials such as crossbeams.

The torque and reaction force produced by the movement of the Manipulator are as follows:

Model number	N6-A1000**	N6-A850**R
Model name	N6	
Max. Horizontal rotating torque (N·m)	800	800
Max. Horizontal reaction force (N)	1900	1600
Max. Vertical rotating torque (N·m)	1100	1100
Max. Vertical reaction force (N)	3200	5100



CAUTION

- If the vibration of the base table is large, reduce the acceleration/deceleration or increase the rigidity of the base table to reduce the vibration. Continued use in a state of large vibration may cause loosening of fastening parts or excessive load on mechanical parts, which may shorten the lifespan.

The plate for the Manipulator mounting face should be 30 mm thick or more and made of steel to reduce vibration. The surface roughness of the steel plate should be 25 μm or less.

The base table must be secured on the floor to prevent it from moving.

The Manipulator installation surface should have a flatness of 0.5 mm or less and an inclination of 0.5 ° or less. If the flatness of the installation surface is improper, the base may be damaged or the robot may not fully show its performance.

When using a leveler to adjust the height of the base table, use a screw with M16 diameter or more.

Example of space for Manipulator base for “Cable direction: Downward” is described in the following section.

3.3.2 Mounting dimensions

Connector

[unit : mm]

If you are passing cables through the holes on the base table, see the figures below.

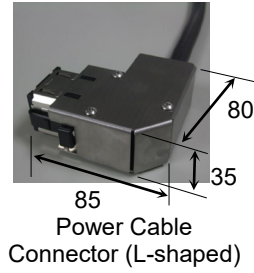
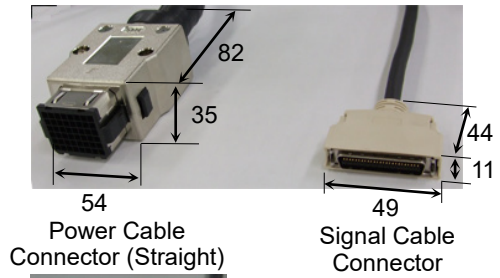
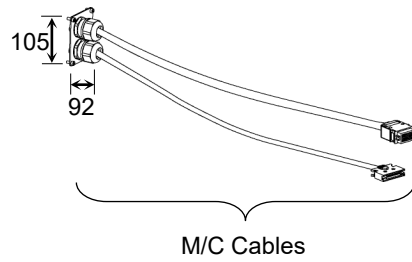

NOTE For environmental conditions regarding space when placing the Controller on the base table, refer to the Controller manual.

 WARNING	<ul style="list-style-type: none"> ■ To ensure safety, a safeguard must be installed for the robot system. For details on the safeguard, refer to the <i>Epson RC+ User's Guide</i>.
--	---

3.6 Connecting the Cables

 WARNING	<ul style="list-style-type: none"> ■ Before performing any replacement procedure, turn OFF the Controller and related equipment, and then disconnect the power plug from the power source. Performing any replacement procedure with the power ON is extremely hazardous and may result in electric shock and/or malfunction of the robot system. ■ Be sure to connect the AC power cable to a power receptacle. DO NOT connect it directly to a factory power source. To shut off power to the robot system, disconnect the power plug from the power source. Performing any work while connecting the AC power cable to a factory power source is extremely hazardous and may result in electric shock and/or malfunction of the robot system. ■ Be sure to connect the cables properly. Do not allow unnecessary strain on the cables. (Do not put heavy objects on the cables. Do not bend or pull the cables forcibly.) The unnecessary strain on the cables may result in damage to the cables, disconnection, and/or contact failure. Damaged cables, disconnection, or contact failure is extremely hazardous and may result in electric shock and/or improper function of the robot system. ■ Before wiring, turn OFF the Controller and related equipment, and then pull up a warning sign (e.g. DO NOT TURN ON THE POWER.). Wiring with the power ON is extremely hazardous and may result in electric shock and/or malfunction of the robot system. ■ When connecting / replacing the brake release unit or the external short connector, turn OFF the power to the Controller and the brake release unit. Inserting and removing the connector while the power is ON may result in electrical shock.
--	--

 CAUTION	<ul style="list-style-type: none"> ■ When connecting the Manipulator and the Controller, make sure that the serial numbers on each equipment match. Improper connection between the Manipulator and Controller may not only cause improper function of the robot system but also safety problems. The connection method varies with the Controller used. For details on the connection, refer to the Controller manual. ■ Only authorized or certified personnel should be allowed to perform wiring. Wiring by unauthorized or uncertified personnel may result in bodily injury and/or malfunction of the robot system. ■ If the manipulator is operated without connecting the brake release unit or the external short connector, the brakes cannot be released and it may cause damage on them. After using the brake release unit, be sure to connect the external short connector to the Manipulator, or check connection of the connector for the brake release unit.
--	--

Grounding

 WARNING	<ul style="list-style-type: none"> ■ Ground resistance must be 100 Ω or less. Improper ground resistance may result in fire and/or electric shock. ■ Do not use the ground line for the Manipulator in common with other ground lines or grounding electrodes for other electric power, motor power, welding devices, etc. Using the ground line for the Manipulator in common with other ground lines or grounding electrodes may result in electric shock and/or malfunction of the robot system. ■ When using metal ducts, metallic conduits, or distributing racks for cable, ground in accordance with national and local electric equipment technical standards. Grounding that does not meet the standards may result in electric shock and/or malfunction of the robot system.
---	---

Follow local regulations for grounding. It is recommended that the core size of the grounding wire be 5.5 mm² or more.

Directly connect the ground line to the Manipulator as shown in the figure below.

N6-A1000**

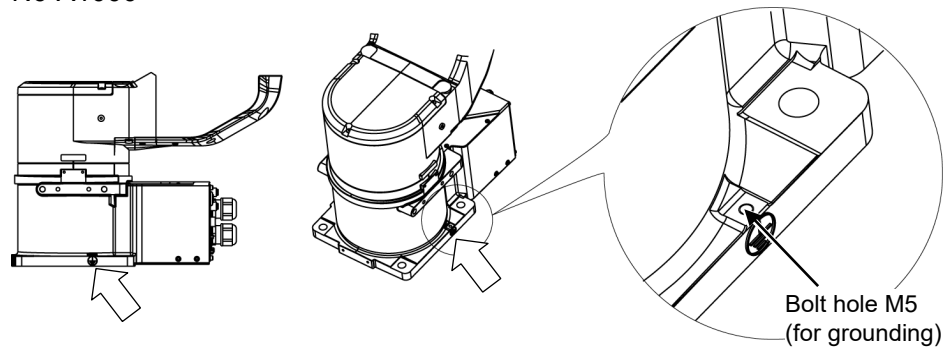

N6-A850**R

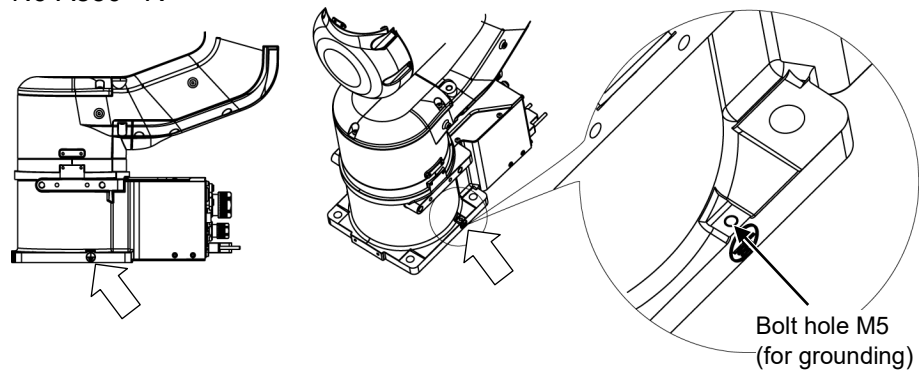

3.7 User Wires and Pneumatic Tubes

 CAUTION	<ul style="list-style-type: none"> Only authorized or certified personnel should be allowed to perform wiring. Wiring by unauthorized or uncertified personnel may result in bodily injury and/or malfunction of the robot system.
---	---

User electrical wires and pneumatic tubes are contained in the cable unit.

N6-A1000**

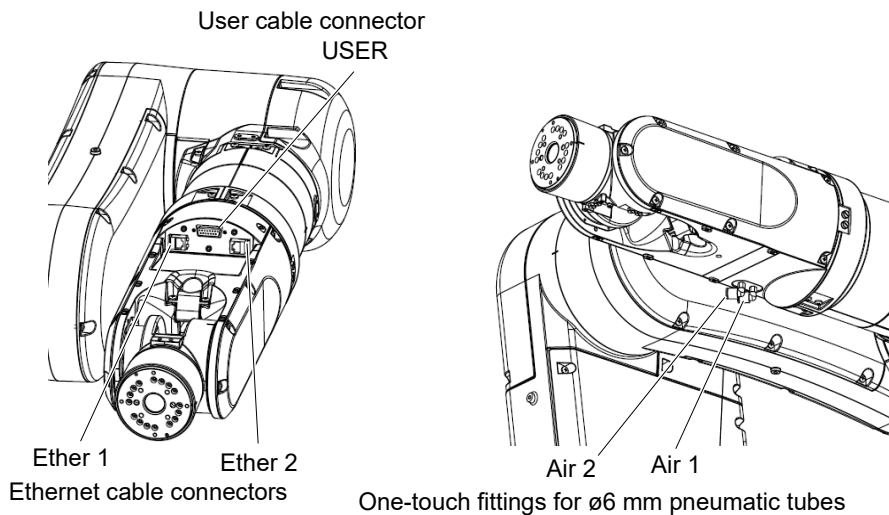

N6-A850**R

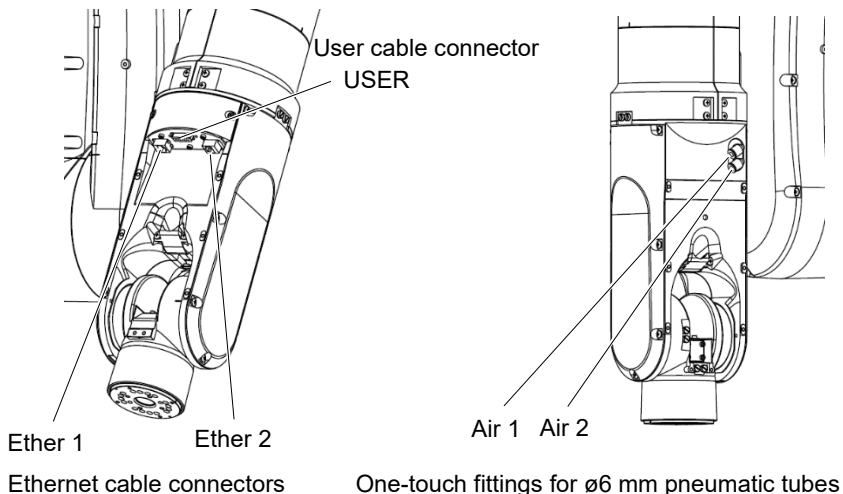

Cable direction: Standard (backward)

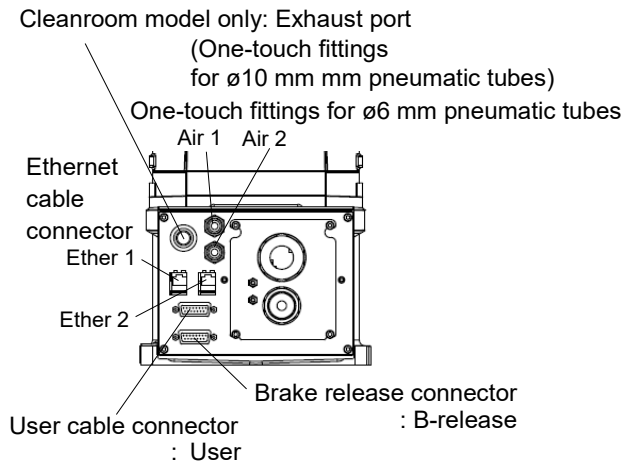

Cable direction: Upward and Downward

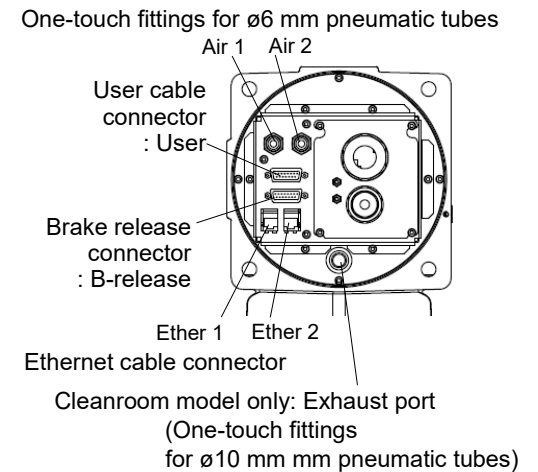

NOTE



The user cable connector and the brake release connector have the same shape. Be careful not to connect the wrong connector.

NOTE



The Ethernet cable connectors Ether 1 and Ether 2 have the same shape. Be careful not to connect the wrong connector.

Electrical wires

Specifications of the user wires D-sub 15-pin

Rated Voltage	Allowable Current	Wires	Nominal Sectional Area	Note
AC/DC30 V	1 A	15	0.106 mm ²	Shielded

Pins with the same number, indicated on the connectors on both ends of the cables, are connected.

Attached connector for the user wires

		Maker	Standard
15 pin	Connector	JAE	DA-15PF-N (Solder type)
	Clamp Hood	HRS	HDA-CTH(4-40)(10) (Connector setscrew: #4-40 UNC)

Two parts are attached for each.

8 pin (RJ45) Cat.5e or equivalent

The commercially available Ethernet cables can be used.

For details, refer to “6. Option”.

Pneumatic tubes

Max. Usable Pneumatic Pressure	Pneumatic Tubes	Outer Diameter × Inner Diameter
0.59 MPa (6 kgf/cm ² : 86 psi)	2	ø6 mm × ø4 mm

3.8 Checking the Basic Orientation

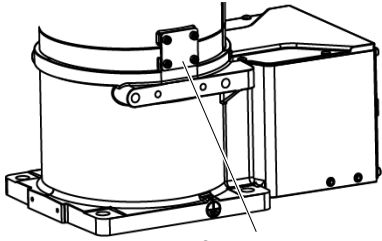
 CAUTION	<ul style="list-style-type: none"> Before operating the robot, make sure to remove the fixing jig for transportation. Operating the robot with the fixing jig may result in damage to the robot. 	 Fixing jig for transportation
---	---	---

At the time of shipment, the Manipulator’s basic orientation shown below is configured as the origin position.

After installing the Manipulator and setup the operating environment, move the Manipulator to the origin position by RC+ and check that it moves to the basic position correctly.

How to return to the origin position

- (1) Turn ON the Controller.
- (2) Turn ON the Manipulator motors.

```

Epson RC+ Command
                > Motor On
    
```

- (3) Move the joints to the origin position.

```

Epson RC+ Command
                > Pulse 0, 0, 0, 0, 0, 0
    
```

Basic Orientation

N6-A1000**

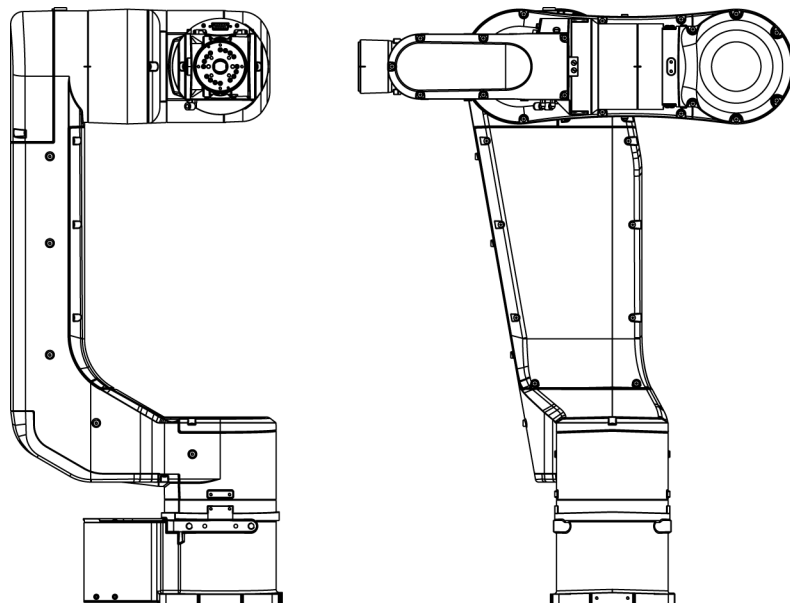

N6-A850**R

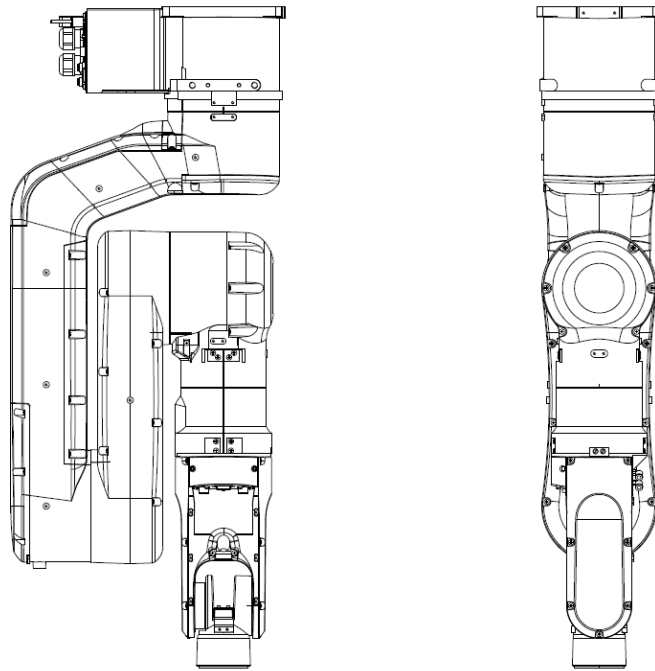

Calibration

After parts (motors, reduction gear units, belts, etc.) have been replaced due to malfunction or any other reason, a gap occurs between the origin positions. The process to compensate the position gap is called “Calibration”.

If the gap still exists and the Manipulator cannot be in the basic orientation after calibration, please contact the supplier of your region.

4. End Effectors

4.1 Attaching an End Effector

Create an end effector for your Manipulator. For details of attaching an end effector, refer to “*Hand Function Manual*”.

Flange dimensions of the wrist attached to the end of Arm #6 is as below.

 CAUTION	<p>■ If you use an end effector equipped with a gripper or chuck, connect wires and/or pneumatic tubes properly so that the gripper does not release the work piece when the power to the robot system is turned OFF. Improper connection of the wires and/or pneumatic tubes may damage the robot system and/or work piece as the work piece is released when the Emergency Stop switch is pressed. I/O outputs are configured at the factory so that they are automatically shut off (0) by power disconnection, the Emergency Stop switch, or the safety features of the robot system.</p> <p>However, the I/O set in the hand function does not turn off (0) when the Reset command is executed or in emergency stop.</p>
---	---

Details of Wrist Flange

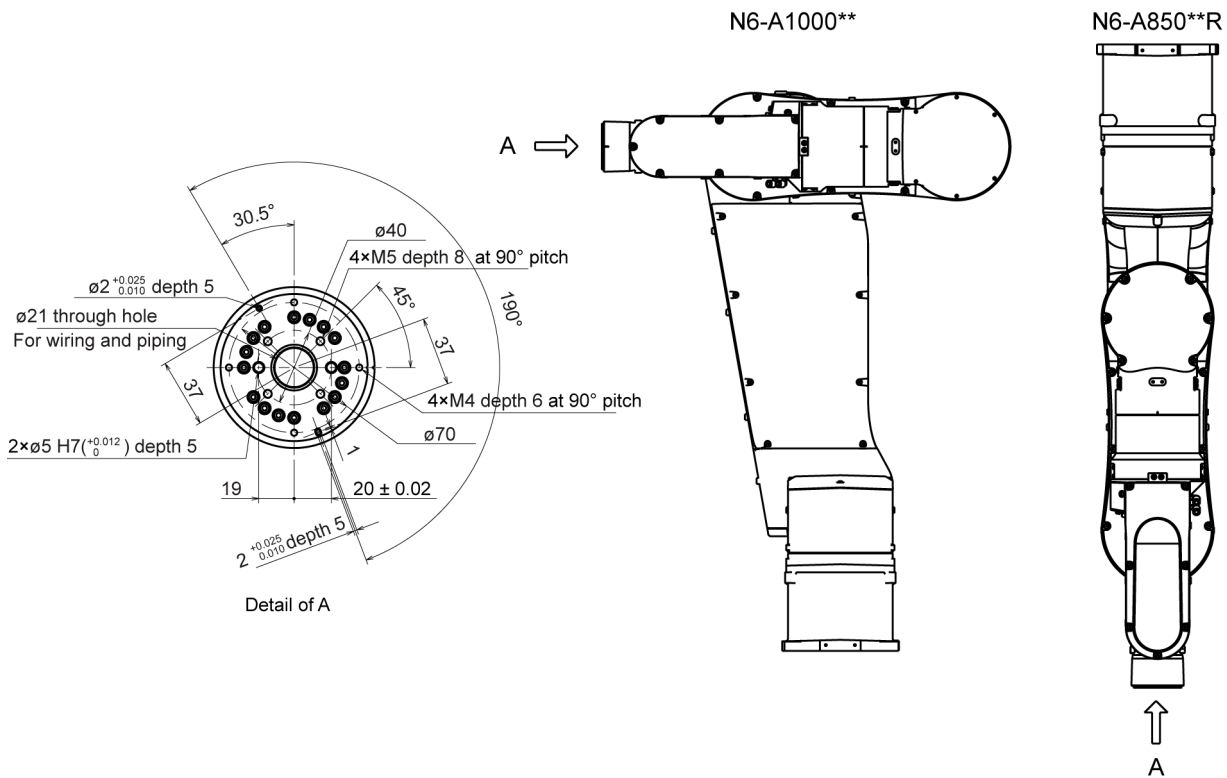

Arm #6

Attach an end effector to the end of the Arm #6 using the M5 bolts.

Screw depth of Arm #6 screw: 8 mm

Layouts

When you operate the Manipulator with an end effector, the end effector may interfere with the Manipulator body depending on the outer diameter of the end effector, the size of the work piece, or the position of the arms. When designing your system layout, pay close attention to the interference area of the end effector.

Hole for wires and tubes

When passing wires and tubes through the hole, you need to note the following.

When operating the Joint #5 or the #6, the wires and the tubes may short or be disconnected due to bent, torsion, and friction.

Make sure to inspect and perform maintenance on the wires and the tubes by yourself.

Compatibility with ISO flange:

For installing the end effector whose mounting dimensions are designed for the ISO flange, the optional tool adapter (ISO flange) is available.

For details, refer to “6. Options”.

4.2 Attaching Camera and Air Valves

The decks are equipped to the Arms #3, #4 and #5 for easy installation of the air valves.

To mount the camera, the camera plate unit is necessary. The optional Camera Plate Unit is available. For details, refer to “6. Options”.

N6-A1000**

[Unit: mm]

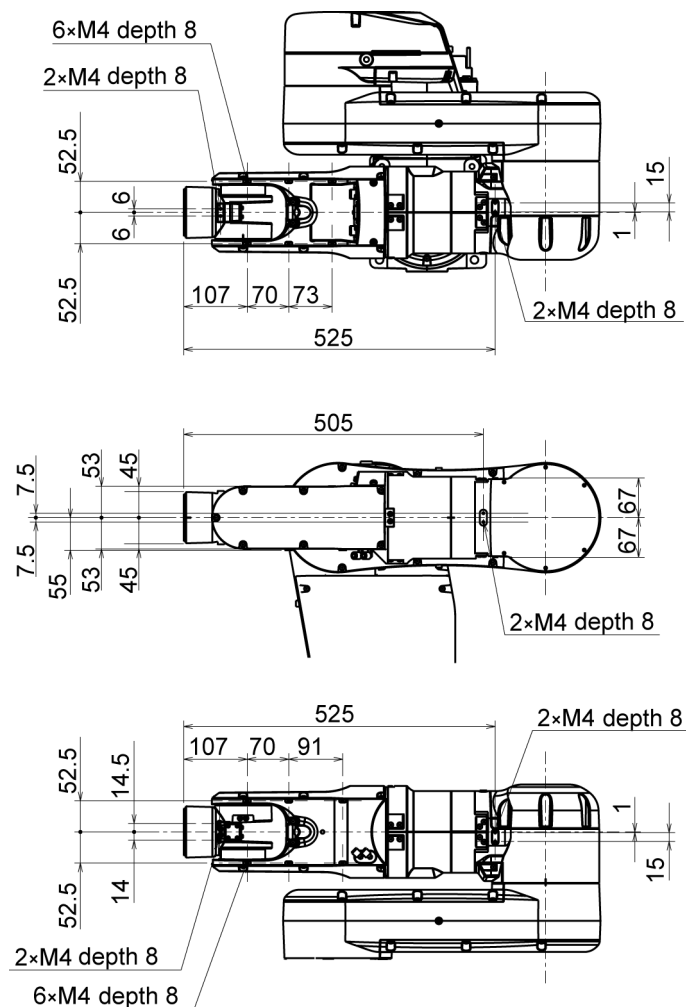

N6-A850**R

[Unit: mm]

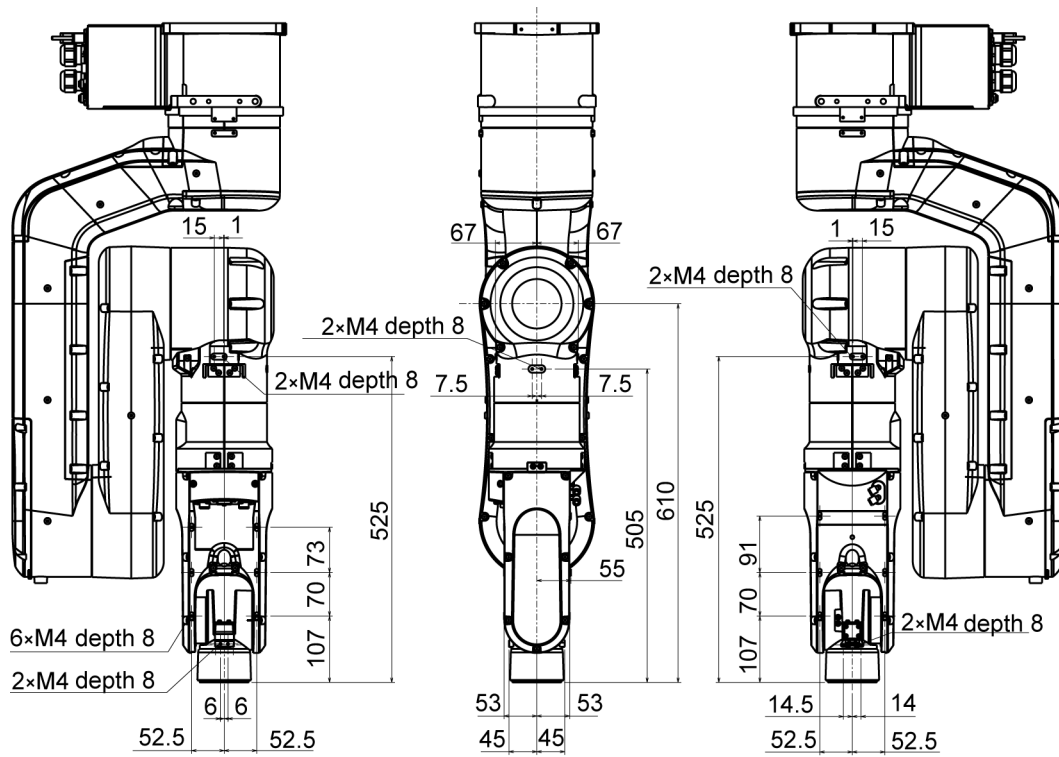

4.3 WEIGHT and INERTIA Settings

The WEIGHT and INERTIA (inertia moment and eccentricity) commands are for setting the load parameters of the Manipulator. These settings optimize the Manipulator motion.

WEIGHT Setting

The WEIGHT command is for setting the load weight. The more the load weight increases, the more the speed and acceleration/deceleration are reduced.

INERTIA Setting

The INERTIA setting is for setting the inertia moment and the eccentricity of the load. The more the inertia moment increases, the more the acceleration and deceleration of the Arm #6 are reduced. The more the eccentricity increases, the more the acceleration and deceleration for the Manipulator movement are reduced.

To ensure optimum Manipulator performance, make sure that the load (weight of the end effector and work piece) and inertia moment of the load are within the maximum rating for the Manipulator, and that Arm #6 does not become eccentric.

If the load or the inertia moment exceeds the ratings or if the load becomes eccentric, follow the steps in “4.3.1 WEIGHT Setting” and “4.3.2 INERTIA Setting”, to set parameters.

Setting parameters makes the operation of the Manipulator optimal, reduces vibration to shorten the operating time, and improves the capacity for larger loads. In addition, it reduces persistent vibration produced when the inertia moment of the end effector and work piece is bigger.

The allowable load for N6 series Manipulators is 6 kg at the maximum.

Due to the limitations of the moment and inertia moment shown in the table below, the load (end effector weight + work piece weight) should also meet these conditions.

Allowable Load

Joint	Allowable Moment	GD ² /4 Allowable Moment of Inertia
#4	15.2 N·m (1.55 kgf·m)	0.42 kg·m ²
#5	15.2 N·m (1.55 kgf·m)	0.42 kg·m ²
#6	9.4 N·m (0.96 kgf·m)	0.14 kg·m ²

Moment

The moment indicates amount of torque applied on the Joints in order to support the gravity on the load (end effector + work piece).

The moment increases as weight of the load and amount of eccentricity increase. As this also increases the load applied on the joint, make sure to keep the moment within the allowable value.

Inertia moment

The inertia moment indicates how difficult the load (end effector + work piece) to rotate when the Manipulator joint starts to rotate (amount of inertia). The inertia moment increases as weight of the load and amount of eccentricity increase. As this also increase the load applied on the joint, make sure to keep the inertia moment within the allowable value.

The moment M (N·m) and inertia moment I (kgm²) when the volume of the load (end effector + work piece) is small can be obtained by the following formula.

$$M \text{ (N·m)} = m \text{ (kg)} \times L \text{ (m)} \times g \text{ (m/s}^2\text{)}$$

$$I \text{ (kgm}^2\text{)} = m \text{ (kg)} \times L^2 \text{ (m}^2\text{)}$$

- m : Weight of load (kg)
- L : Eccentric quantity of load (m)
- g : Gravitational acceleration (m/s²)

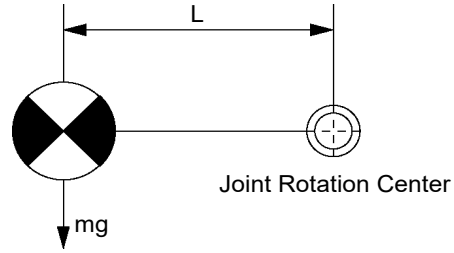

Design the end effector so that the moment M and the inertia moment I do not exceed the allowable load.

The eccentric quantity of load L should satisfy the following:

- Less than 260 mm from the Arm #5 rotation center (160 mm or less from the flange)
- Less than 160 mm from the Arm #6 rotation center

Example: When the load is 3 kg and the center of gravity is 120 mm from the flange:

$$m=3.0\text{kg}, L=120+100=220\text{mm}=0.220\text{m}$$

The moment M and the inertia moment are below the allowable load as follows:

$$\text{Moment } M : 3.0 \text{ kg} \times 0.220\text{m} \times 9.8 \text{ m/s}^2 = 6.468 \text{ N·m} < 15.2 \text{ N·m}$$

$$\text{Inertia moment } I : 3.0 \text{ kg} \times (0.220 \text{ m})^2 = 0.1452 \text{ kgm}^2 < 0.42 \text{ kgm}^2$$

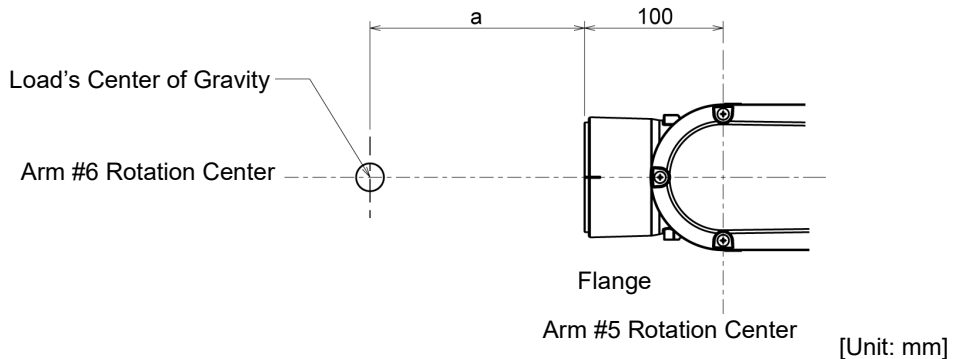

4.3.1 WEIGHT setting

 CAUTION	<ul style="list-style-type: none"> ■ Set the total weight of the end effector and the work piece smaller than the maximum payload. The N6 series Manipulators can operate without limitations on the condition unless and until the load exceeds this maximum payload. Always set the Weight parameters of the WEIGHT command according to the load. Setting a value that is smaller than the actual load may cause errors, excessive shock, insufficient function of the Manipulator, and/or shorten the life cycle of parts/mechanisms.
--------------------	---

The acceptable weight capacity (end effector and work piece) for N6 series Manipulators is as follows:

Rated	Maximum
3 kg	6 kg

Change the setting of the Weight parameter according to the load.

After changing the Weight parameter setting, the maximum acceleration/deceleration and speed of the robot system corresponding to the load is set automatically.

Setting method of Weight parameters

Epson
RC+

Select [Tools]-[Robot Manager]-[Weight] panel and set the value in [Weight:].

You may also execute the Weight command from [Command Window].

Load on the Manipulator

When you attach the equipment to the decks on the upper arm, convert its weight into equivalent weight assuming that the equipment is attached to the end of the Arm #6. Then, this equivalent weight added to the load will be a Weight parameter.

Calculate the Weight parameter by using the formula below and enter the value.

Weight Parameter Formula

$$\text{Weight parameter} = M_w + W_a + W_b$$

M_w : Load on the fore end of Arm #6 (kg)

W_a : Equivalent weight of the Arm #3 deck (kg)

W_b : Equivalent weight of the Arm #5 deck (kg)

$$W_a = M_a (L_a)^2 / (L)^2$$

$$W_b = M_b (L_b)^2 / (L)^2$$

M_a : Weight of the air valve on the Arm #3 deck

M_b : Weight of the camera on the Arm #5 deck

L : Length of the upper arm (mm)

L_a : Distance between the Joint #3 and the center of gravity of the air valve on the Arm #3 deck (mm)

L_b : Distance between the Joint #3 and the center of gravity of the camera on the Arm #5 deck (mm)

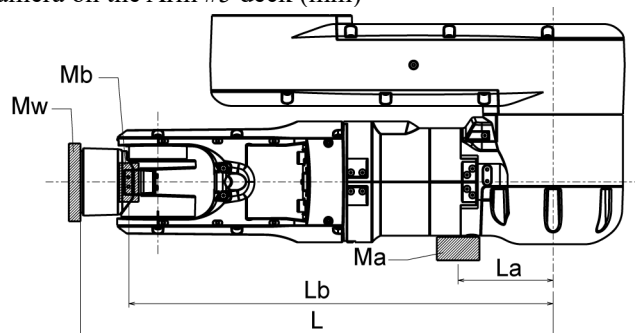

<Example> The fore end of the Arm #6 is 610 mm (L) away from the Joint #3 of N6-A1000**

Load on the fore-end of Arm #6 is 3.0 kg (M_w).

Load on the Arm #3 deck is 1.0 kg (M_a).

The deck is 120 mm (L_a) away from Joint #3.

Load on the Arm #5 deck is 0.5 kg (M_b).

The deck is 550 mm (L_b) away from the Joint #3.

$$W_a = 1.0 \times 120^2 / 610^2 = 0.039$$

$$W_b = 0.5 \times 550^2 / 610^2 = 0.41$$

$$M_w + W_a + W_b = 3.0 + 0.039 + 0.41 = 3.449 \rightarrow 3.5 \text{ (round up)}$$

Enter “3.5” for the Weight parameter.

Automatic speed setting by Weight parameter

N6-A1000**

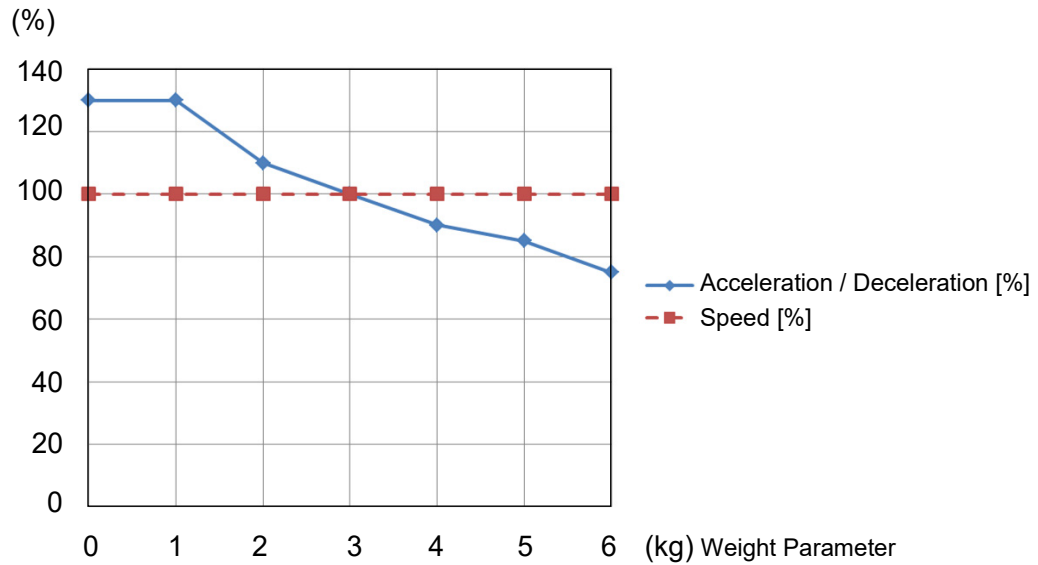

N6-A850**R

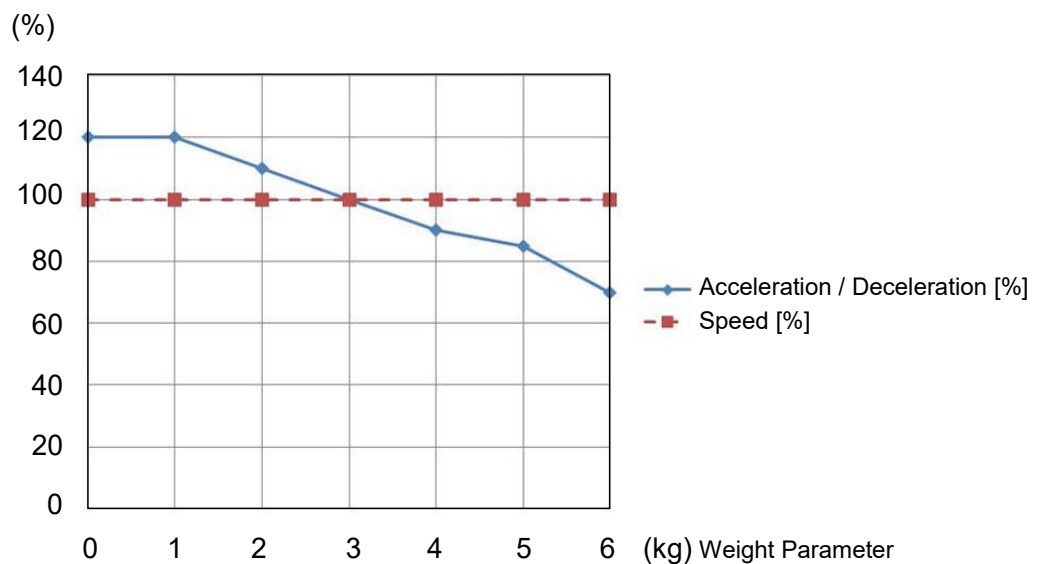

The percentages in the graphs are based on the speed at rated weight (3 kg) as 100%.

4.3.2 INERTIA setting

Inertia Moment and the INERTIA Setting

The inertia moment is defined as “the ratio of the torque applied to a rigid body and its resistance to motion”. When the Manipulator operates with objects such as an end effector attached to the Arm #6, the moment of inertia of load must be considered.

 CAUTION	<ul style="list-style-type: none"> ■ The inertia moment of the load (weight of the end effector and work piece) must be 0.14 kg·m² or less. The N6 series Manipulators are not designed to work with inertia moment exceeding 0.14 kg·m². Always set the inertia moment (INERTIA) parameter according to the inertia moment. Setting a value that is smaller than the actual inertia moment may cause errors, excessive shock, insufficient function of the Manipulator, and/or shorten the life of parts/mechanisms.
---	--

The acceptable inertia moment of load for N6 series Manipulators is 0.03 kg·m² nominal rating and 0.14 kg·m² maximum. Change the setting of the inertia moment according to the inertia moment of the load using the INERTIA setting. After the setting has been changed, the maximum acceleration/deceleration speed of Arm #6 responding to “inertia moment” is set automatically.

Inertia moment of load on Arm #6

The inertia moment of the load (weight of the end effector and work piece) on the Arm #6 can be set by the “inertia moment (INERTIA)” parameter of the INERTIA setting.

Epson
RC+

Select [Tools]–[Robot Manager]–[Inertia] panel and enter the value in [Load inertia:].
You may also execute the INERTIA setting from [Command Window].

Eccentric Quantity and the INERTIA Setting



- The eccentric quantity of the load (weight of the end effector and work piece) must be 160 mm or less. The N6 series Manipulators are not designed to work with eccentric quantity exceeding 160 mm. Always set the eccentric quantity parameter according to the eccentric quantity. Setting a value that is smaller than the actual eccentric quantity may cause errors, excessive shock, insufficient function of the Manipulator, and/or shorten the life cycle of parts/mechanisms.

The acceptable eccentric quantity of the load for N6 series Manipulators is 50 mm at nominal rating and 160 mm at maximum. When the eccentric quantity of the load exceeds the rating, change the setting of eccentric quantity parameter using the INERTIA setting. After changing the setting, the maximum acceleration/deceleration speed of Manipulator corresponding to “eccentric quantity” is set automatically.

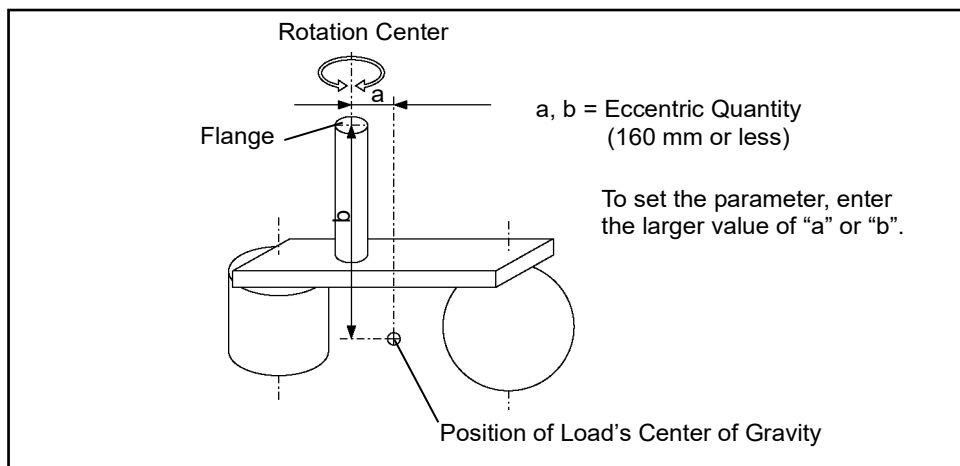

Eccentric Quantity

Eccentric quantity of load on Arm #6

The eccentric quantity of the load (weight of the end effector and work piece) on the Arm #6 can be set by the “eccentric quantity” parameter of the INERTIA setting. Enter the larger value of either “a” or “b” in the figure above to [Eccentricity].

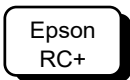

Select [Tools]-[Robot Manager]-[Inertia] panel and enter the value into [Eccentricity:]. You may also execute the INERTIA setting from [Command Window].

Automatic acceleration/deceleration setting by INERTIA (eccentric quantity)

Automatic setting by inertia moment setting

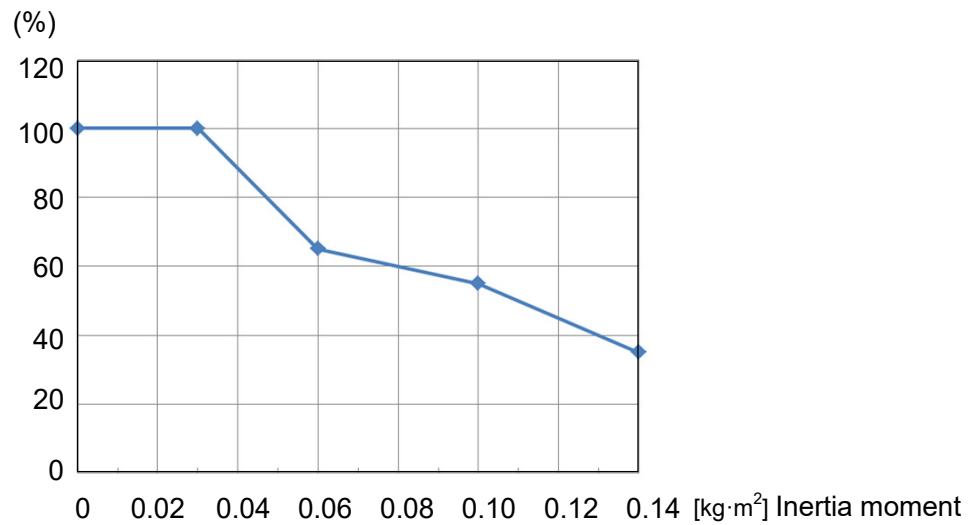

* The percentage in the graph is based on the acceleration / deceleration at rated eccentricity (0.03 kg·m²) as 100%.

Automatic setting by eccentricity setting

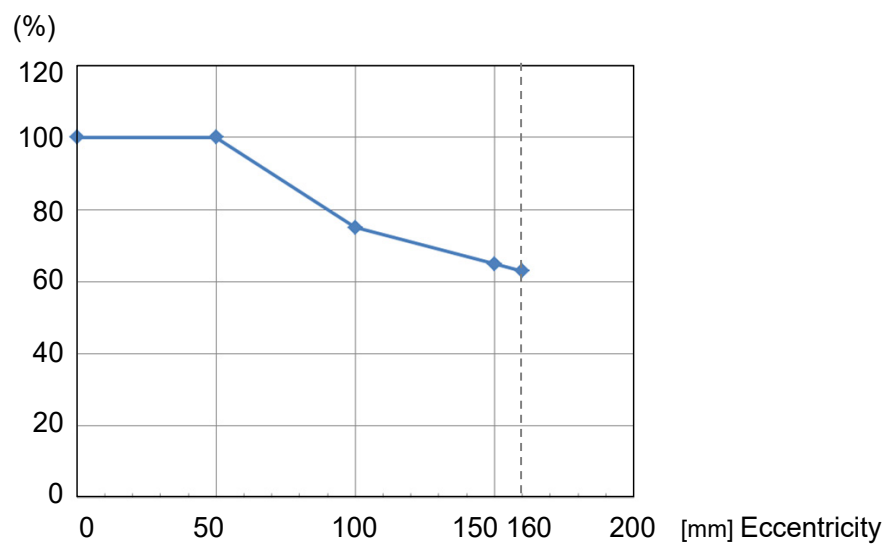

* The percentage in the graph is based on the acceleration / deceleration at rated eccentricity (50 mm) as 100%.

Calculating the Inertia Moment

Refer to the following example formulas to calculate the inertia moment of the load (end effector with work piece).

The inertia moment of the entire load is calculated by the sum of (a), (b), and (c).

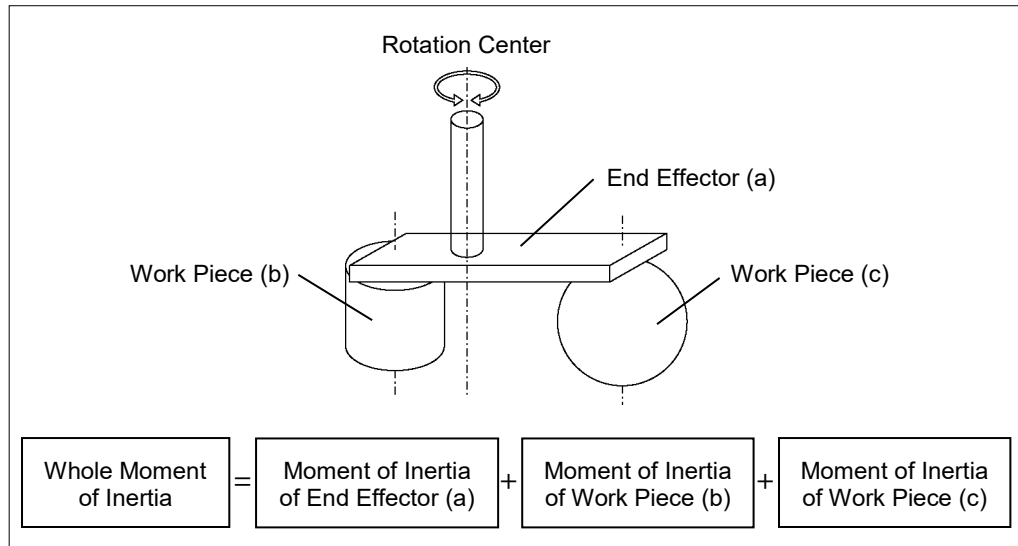

The methods for calculating the inertia moment for (a), (b), and (c) are shown in this and the next page. Figure out the whole inertia moment using the basic formulas below.

(a) Inertia moment of a rectangular parallelepiped

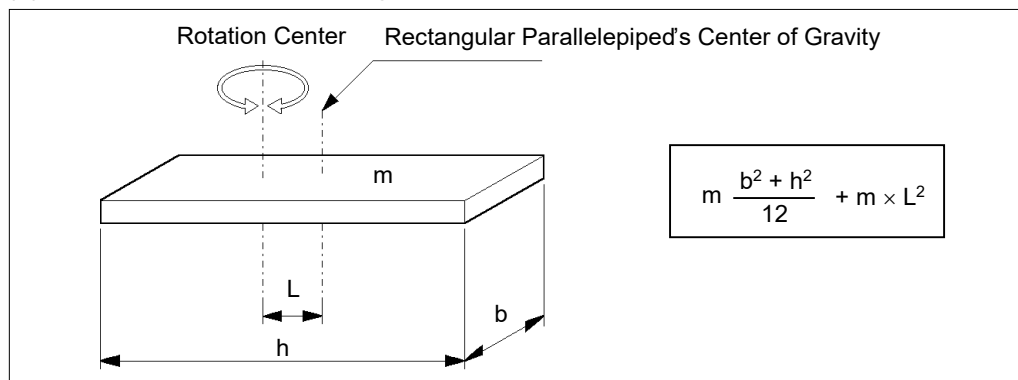

(b) Inertia moment of a cylinder

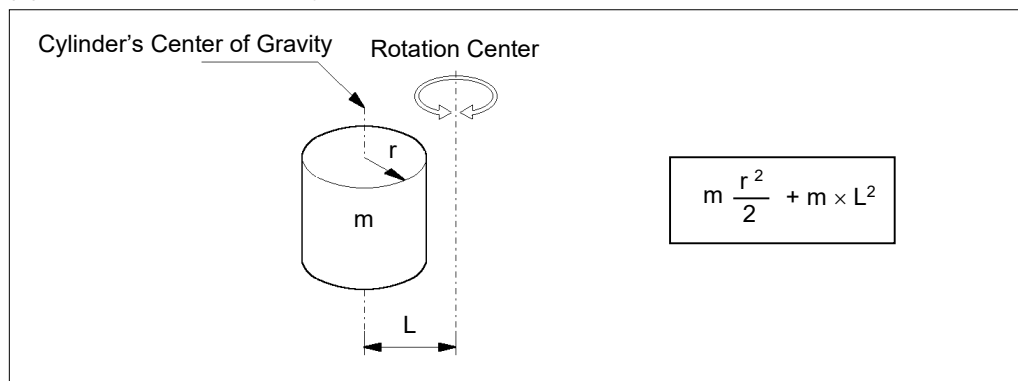

(c) Inertia moment of a sphere

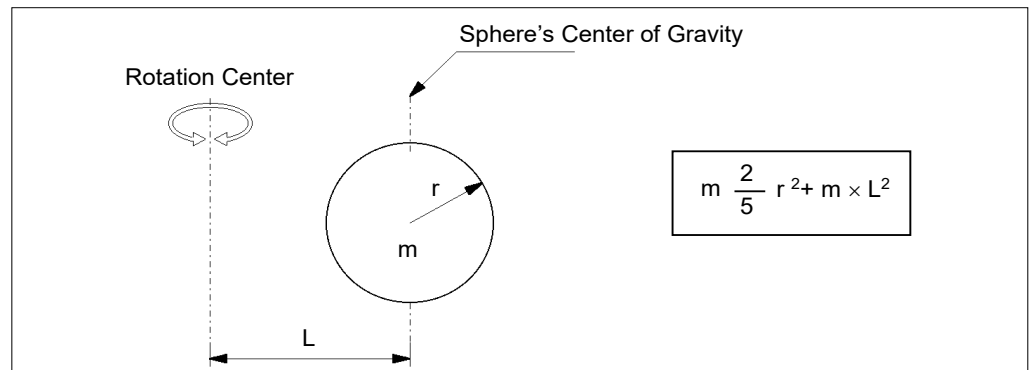

4.4 Precautions for Auto Acceleration/Deceleration

The speed and acceleration/deceleration of the Manipulator motion are automatically optimized according to the values of WEIGHT and INERTIA and the Manipulator's postures.

WEIGHT Setting

The speed and acceleration/deceleration of the Manipulator are controlled according to the load weight set by the WEIGHT command.

The more the load weight increases, the more the speed and acceleration/deceleration are reduced to prevent residual vibration.

INERTIA Setting

The acceleration/deceleration of Arm #6 are controlled according to the inertia moment set by the INERTIA setting. The acceleration/deceleration of the whole Manipulator are controlled according to the eccentricity set by the INERTIA setting. The more the inertia moment and eccentricity of the load increase, the more the acceleration/ deceleration are reduced.

Auto Acceleration/Deceleration According to Manipulator's Posture

The acceleration/deceleration are controlled according to the Manipulator's posture. When the Manipulator extends its arms or when the movement of the Manipulator produces vibration frequently, the acceleration/deceleration are reduced.

Set appropriate values for WEIGHT and INERTIA so that the Manipulator operation is optimized.

5. Motion Range



WARNING

- When limiting the motion range for safety, be sure to set by the pulse range. Failure to do so may cause serious safety problems.

The motion range is preset at the factory as describes in “2.4 Standard Motion Range”. This is the maximum motion range of the Manipulator.

Motion range is set by the following two methods:

1. Setting by pulse range (for all arms)
2. Setting the Cartesian (rectangular) range in the X, Y coordinate system of the Manipulator

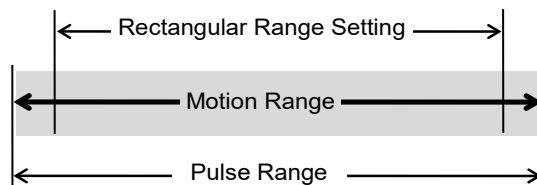

When the motion range is limited due to layout efficiency or safety, follow the descriptions in 5.1 through 5.3 to set the range.

5.1 Motion Range Setting by Pulse Range (for Each Joint)

Pulses are the basic unit of Manipulator motion. The motion range of the Manipulator is controlled by the pulse range (the lower limit and the upper limit) of each axis.

Pulse values are read from the encoder output of the servo motor.

The pulse range should be set within the maximum motion range.

NOTE



Once the Manipulator receives an operating command, it checks whether the target position specified by the command is within the pulse range before operating. If the target position is out of the set pulse range, an error occurs and the Manipulator does not move.

Epson
RC+

The pulse range can be set in [Tools]-[Robot manager]-[Range] panel.
You may also execute the Range command from the [Command Window].

5.1.1 Max. Pulse Range: N6-A1000**

Joint #1 (N6-A1000**)

When viewing from the arrow on the right figure, pulse values in counterclockwise direction are positive (+) and values in clockwise direction are negative (-).

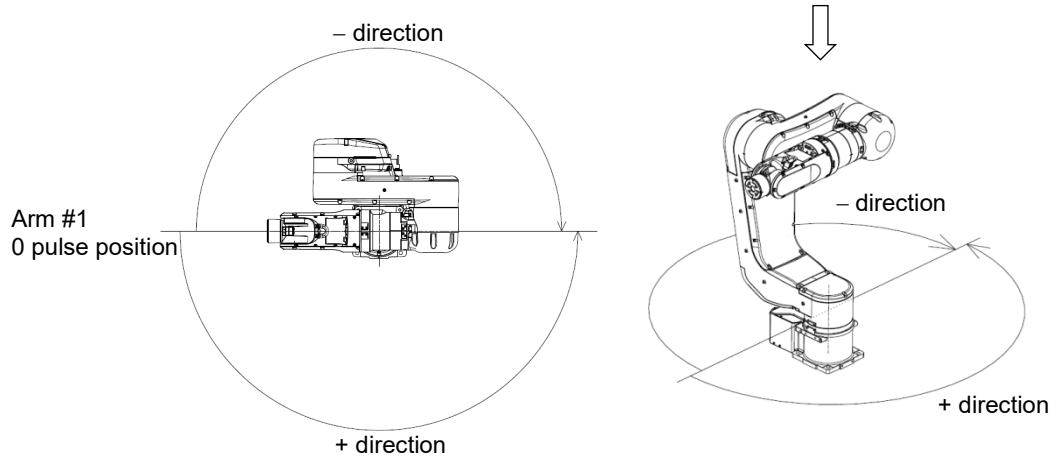

Angle (°) : ±180
 Pulse (pulse) : ±6619136

Joint #2 (N6-A1000**)

When viewing from the arrow on the right figure, pulse values in counterclockwise direction are positive (+) and values in clockwise direction are negative (-).

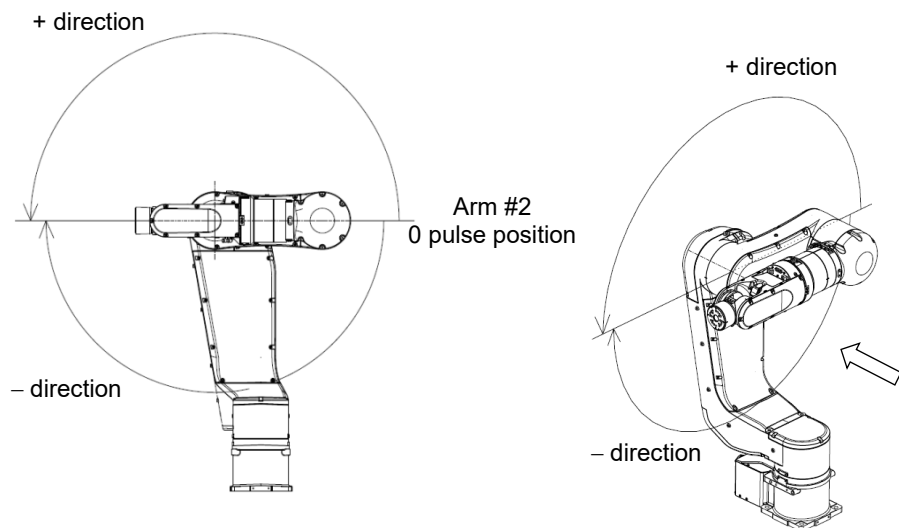

Angle (°) : ±180
 Pulse (pulse) : ±6619136

Joint #3 (N6-A1000)**

When viewing from the arrow on the right figure, pulse values in counterclockwise direction are positive (+) and values in clockwise direction are negative (-).

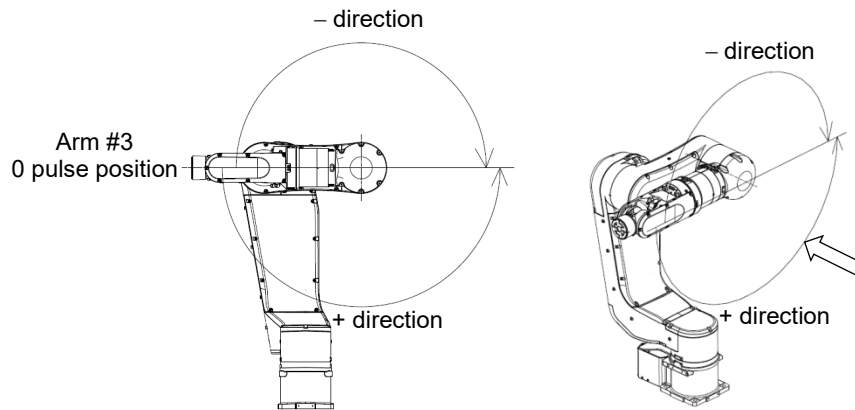

Angle (°) : ± 180
 Pulse (pulse) : ± 5308416

Joint #4 (N6-A1000)**

When viewing from the arrow on the right figure, pulse values in counterclockwise direction are positive (+) and values in clockwise direction are negative (-).

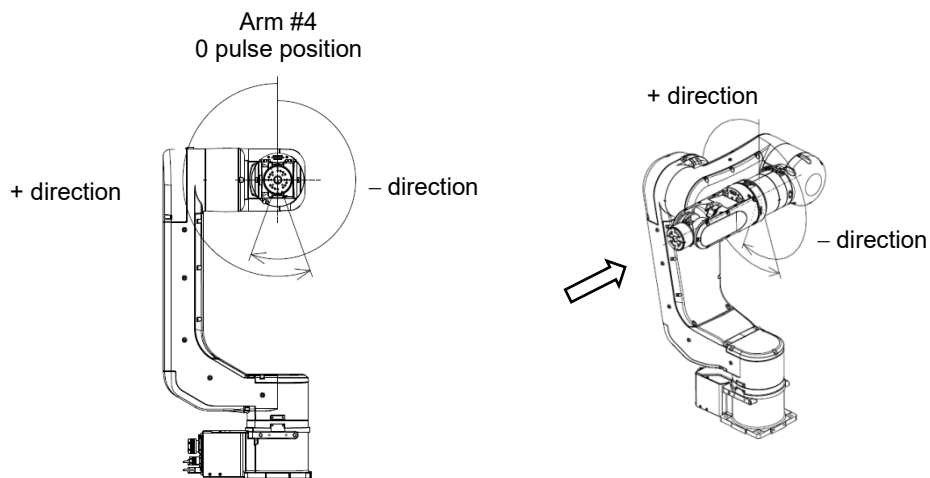

Angle (°) : ± 200
 Pulse (pulse) : ± 5898240

Joint #5 (N6-A1000)**

When viewing from the arrow on the right figure, pulse values in counterclockwise direction are positive (+) and values in clockwise direction are negative (-).

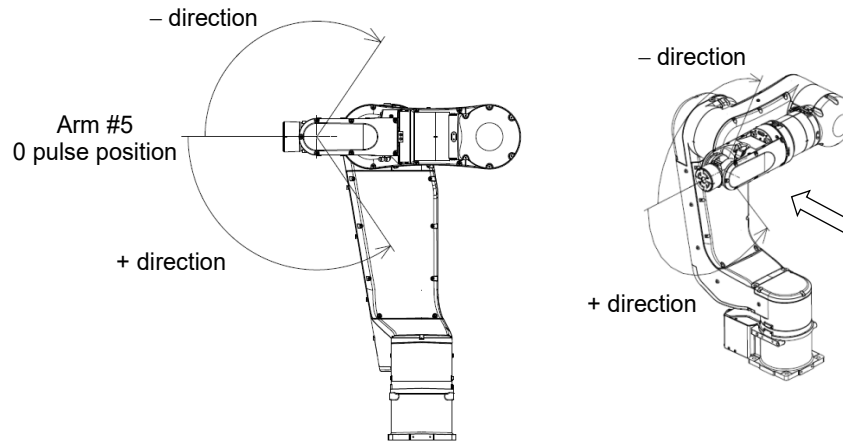

Angle (°) : ± 125
 Pulse (pulse) : ± 3640889

Joint #6 (N6-A1000)**

When viewing from the arrow on the right figure, pulse values in counterclockwise direction are positive (+) and values in clockwise direction are negative (-).

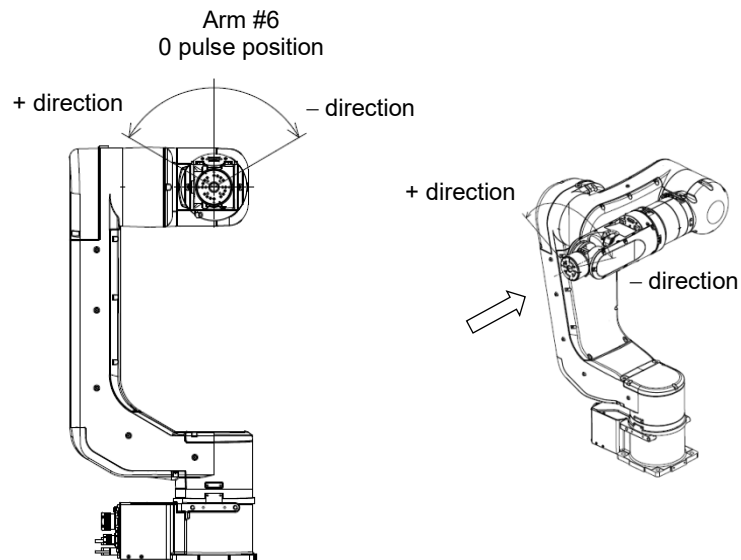

Angle (°) : ± 360
 Pulse (pulse) : ± 8773632

5.1.2 Max. Pulse Range: N6-A850**R

Joint #1 (N6-A850**R)

When viewing from the arrow on the right figure, pulse values in counterclockwise direction are positive (+) and values in clockwise direction are negative (-).

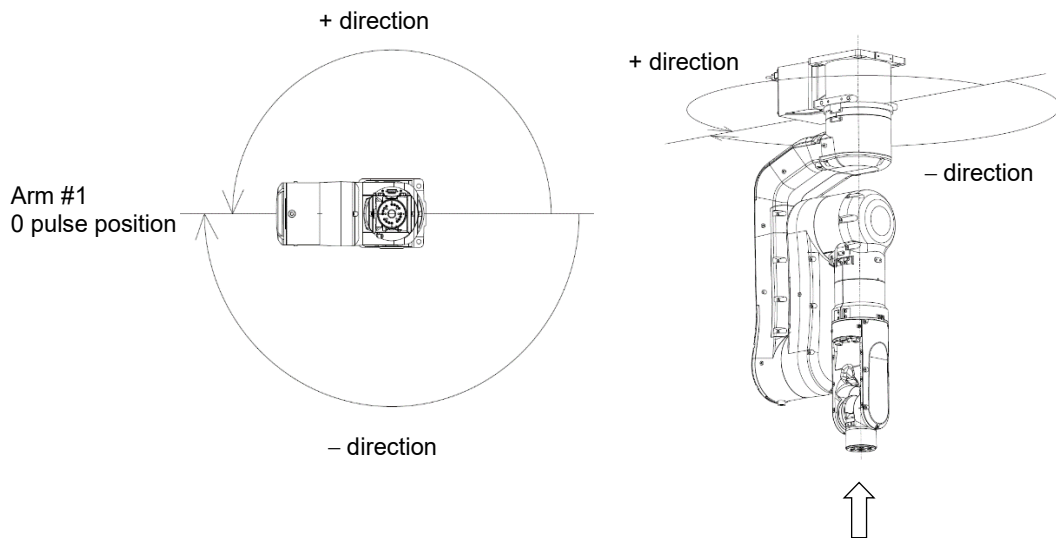

Angle (°) : ± 180
 Pulse (pulse) : ± 6619136

Joint #2 (N6-A850**R)

When viewing from the arrow on the right figure, pulse values in counterclockwise direction are positive (+) and values in clockwise direction are negative (-).

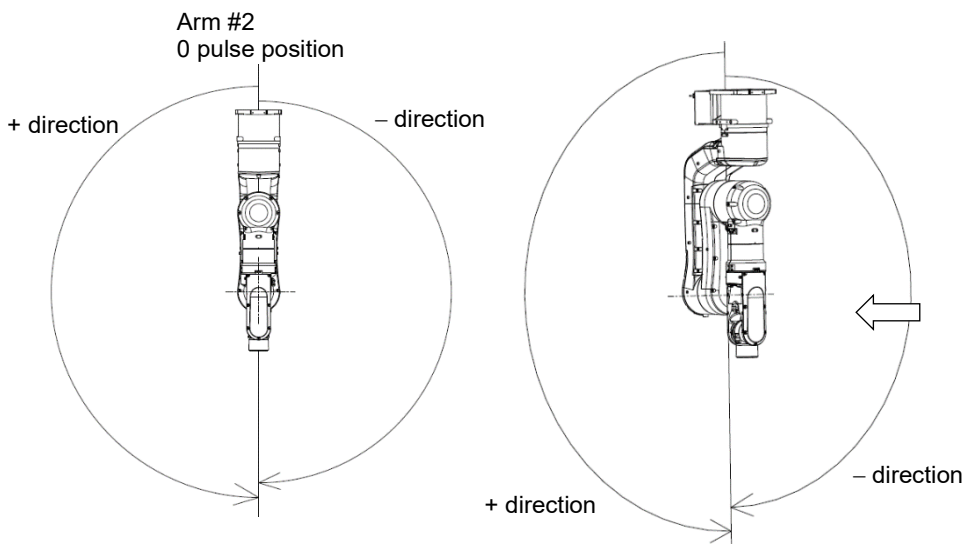

Angle (°) : ± 180
 Pulse (pulse) : ± 6619136

Joint #3 (N6-A850R)**

When viewing from the arrow on the right figure, pulse values in counterclockwise direction are positive (+) and values in clockwise direction are negative (-).

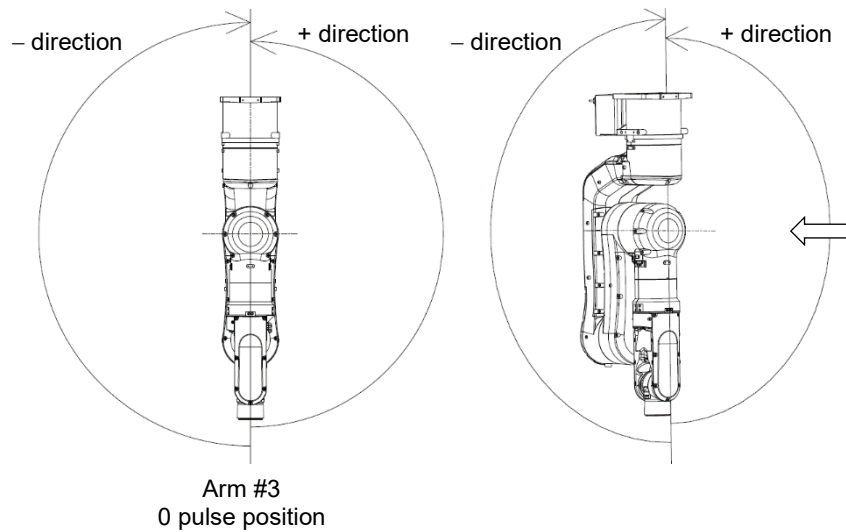

Angle (°) : ±180
Pulse (pulse) : ±5308416

Joint #4 (N6-A850R)**

When viewing from the arrow on the right figure, pulse values in counterclockwise direction are positive (+) and values in clockwise direction are negative (-).

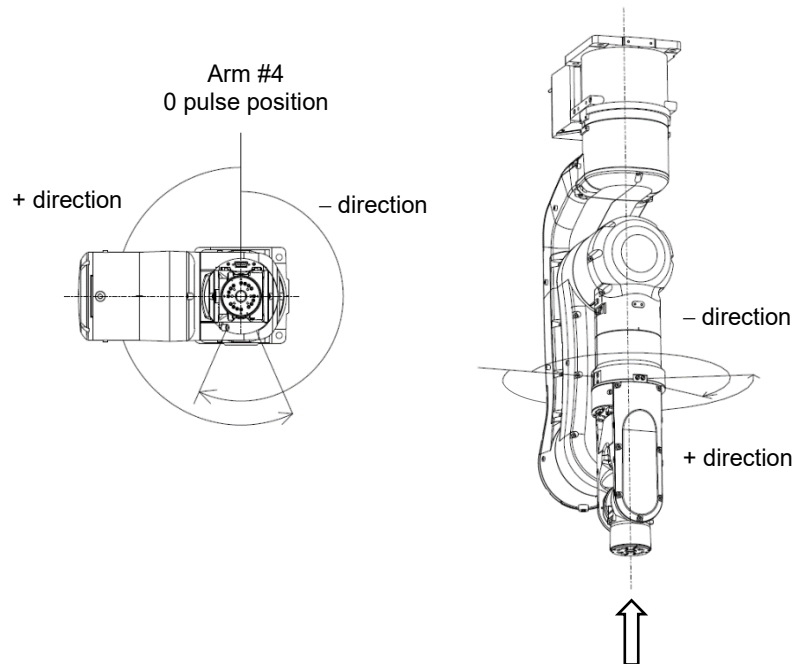

Angle (°) : ±200
Pulse (pulse) : ±5898240

Joint #5 (N6-A850R)**

When viewing from the arrow on the right figure, pulse values in counterclockwise direction are positive (+) and values in clockwise direction are negative (-).

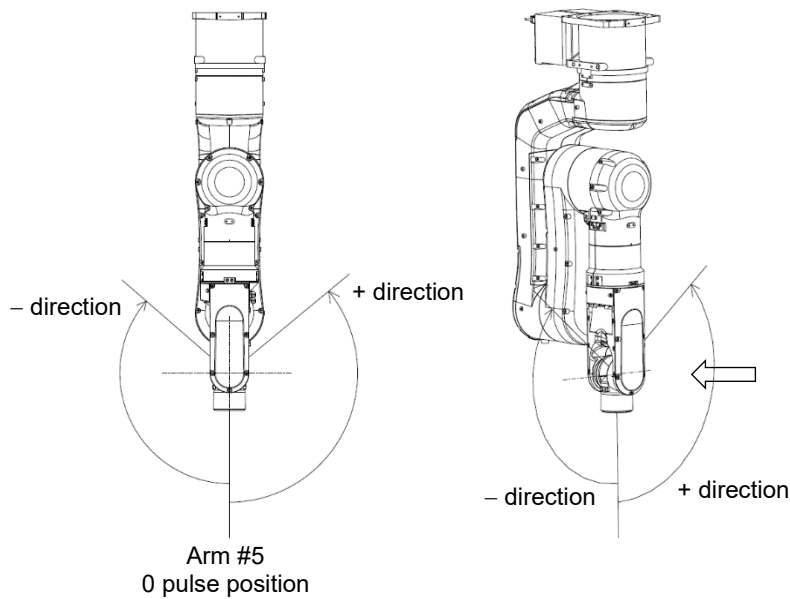

Angle (°) : ±125
Pulse (pulse) : ±3640889

Joint #6 (N6-A850R)**

When viewing from the arrow on the right figure, pulse values in counterclockwise direction are positive (+) and values in clockwise direction are negative (-).

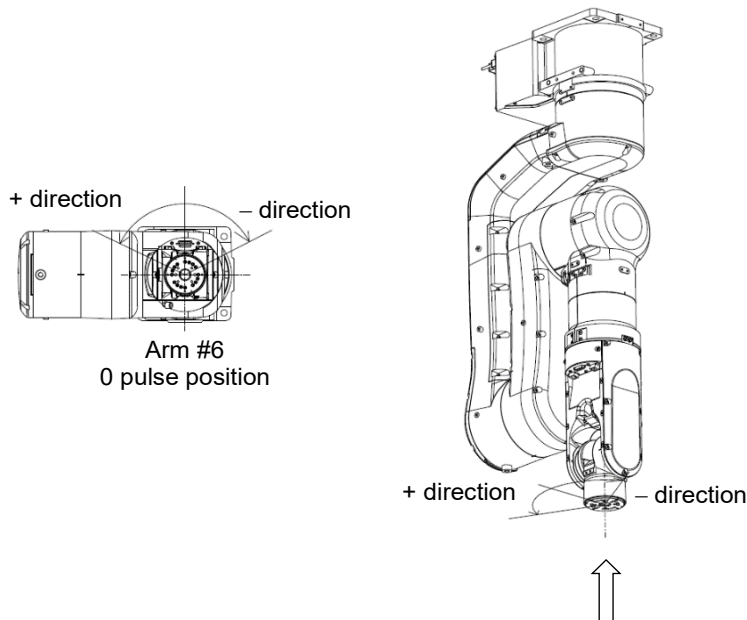

Angle (°) : ±360
Pulse (pulse) : ±8773632

5.2 Restriction of Manipulator Operation

To prevent the arms of the Manipulator from interfering each other, the Manipulator operation is restricted as follows:

Combination restriction of joint angles

The motion ranges of the Joints #2 and #3 are defined according to the combinations of their angles. If the combination of the joint angles falls the painted areas in the below figure, the Manipulator motion will be restricted.

Error: 4066

If the arm motion of the Manipulator is operated with a motion which will interfere with itself between the current position and the target position, “Error: 4066” occurs.

The error occurs in PTP motion and CP motion. “Error: 4066” occurs in the following situations:

When the target position is inside the combination restriction area of joint angle (Fig. 1: Green, Blue).

[Remedy] Change the target position and avoid “Error: 4066”.

N6-A1000**

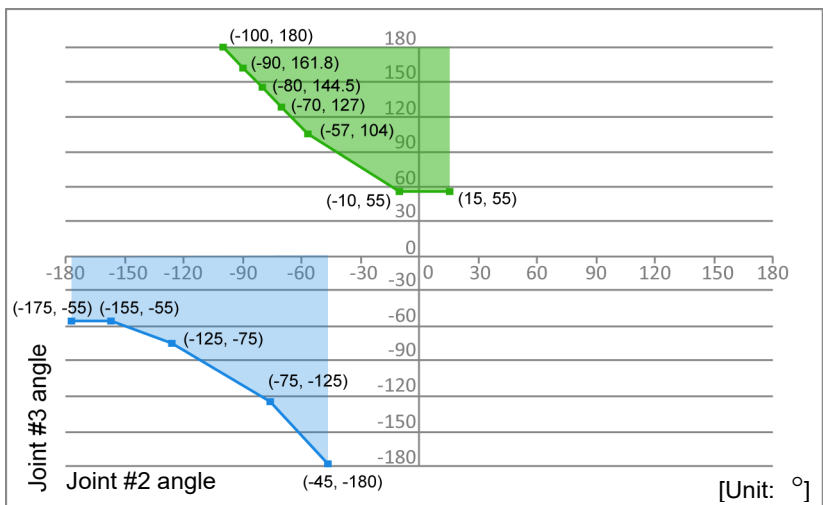

N6-A850R**

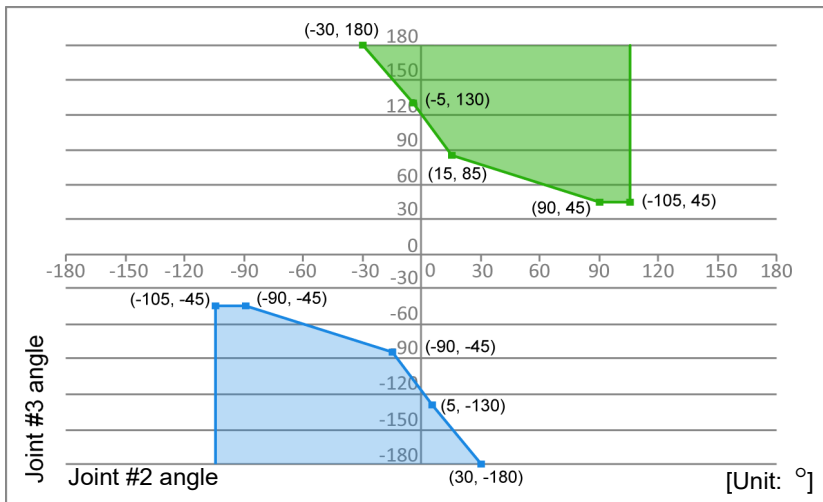

Fig. 1: Combination restriction of joint angle

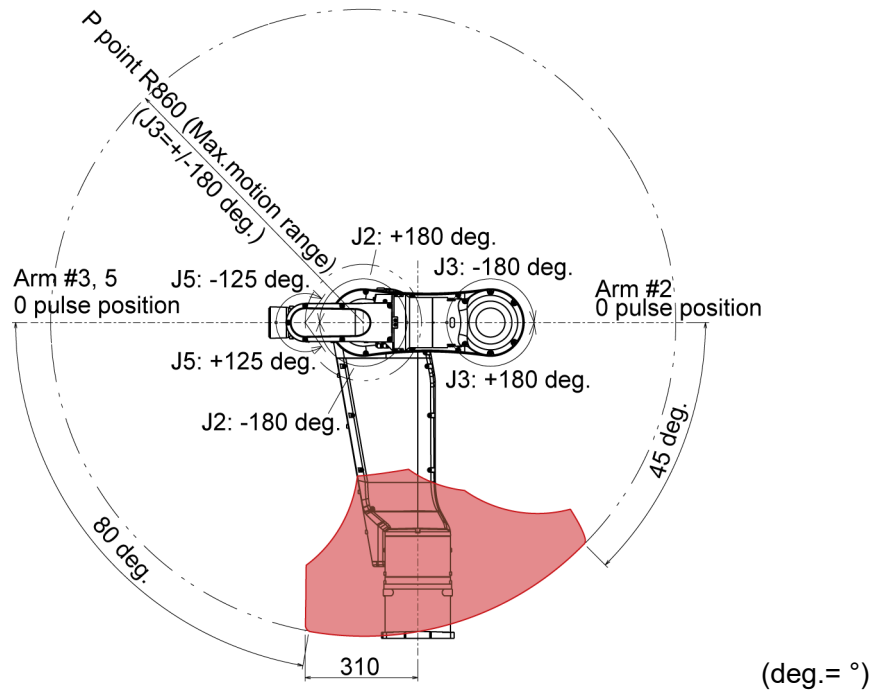

Fig 2: Area that “Error: 4066, 4248” occurs

Green and blue areas in Fig. 1 are red area in Fig. 2.

When the arm/elbow orientation of the target position is in a restricted orientation:

[Remedy] Change the arm/elbow orientation and avoid “Error: 4066”.

When the arm/elbow orientation of the current position is in a restricted orientation:

Normally, the arm/elbow orientation of the current position will not be able to move to a restricted orientation since “Error: 4066” will occur before operating the motion. However, if using jog or releasing the brake to move the Manipulator by hand, the arm/elbow orientation of the current position will be able to move to a restricted orientation. If “Error: 4066” occurs when the motion command “Go Pulse(0,0,0,0,0,0)” is executed, refer to the following remedy to avoid “Error: 4066”.

[Remedy] Move the Manipulator by Jog motion.

Release a brake and move the Manipulator by hand.

Error: 4248

When Manipulator enters into the red area (Fig. 2), “Error: 4248” occurs. The error occurs in PTP motion and occurs order to avoid a collision to Manipulator itself (Fig. 3).

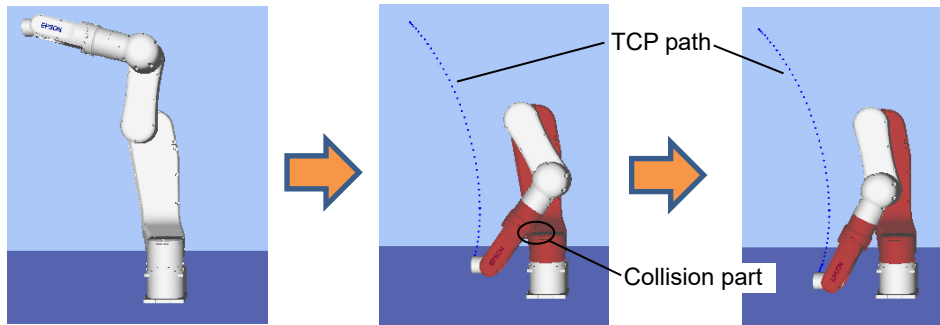

Fig. 3: Motion that collides with the Manipulator itself

Also, “Error: 4248” will occur when the specified target position is inside the orange area (Fig.4).

As shown in [Remedy], if “Error: 4248” occurs, set relay points outside of the orange area.

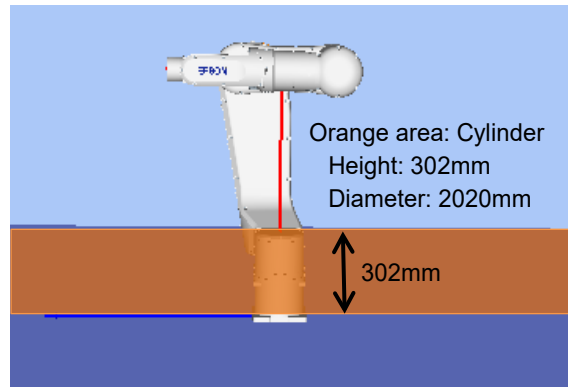

Fig. 4: Range of target position that “Error: 4248” will occur

The range of Fig. 4 is when Tool 0 and Local 0.

```
[Remedy] Set relay points to avoid a collision.
P1 = XY (-420,0, 1200, 0, -90, 0) /R /A /NF
P2 = XY (0,420, 280, 0, -90, -90) /R /B /F
P3 = XY (0,420, 305, 0, -90, -90) /R /B /F
```

```
Go P1
Go P3 CP ' Relay point
Go P2

Go P3 CP ' Relay point
Go P1
```

“Error: 4248” will occur again even the Manipulator is moved outside of the orange area (Fig. 4) in PTP motion after “Error: 4248” occurred. In that case, the Manipulator is in the red area (Fig. 2). Move the Manipulator from the area by moving the Joint #2 or #3 by Jog motion in Joint mode.

NOTE If the Manipulator moves at high speed, it will collide with itself after detecting “Error: 4248”.

Make sure to check the motion by simulator or motion in low power mode.

5.3 Coordinate System

The origin point is where the Manipulator's installation face intersects with the rotation axis of Joint #1.

For details on the coordinate system, refer to the *Epson RC+ Users Guide manual*.

N6-A1000**

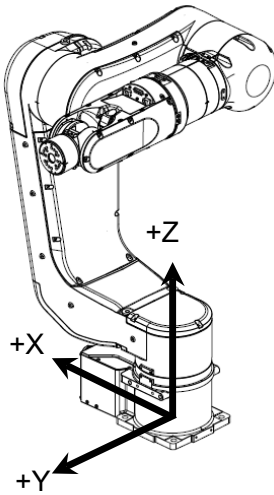

N6-A1000**R

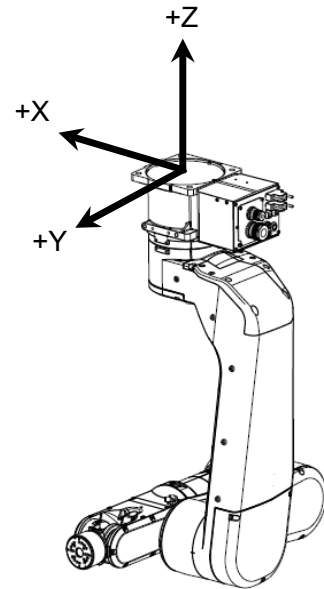

N6-A850**R

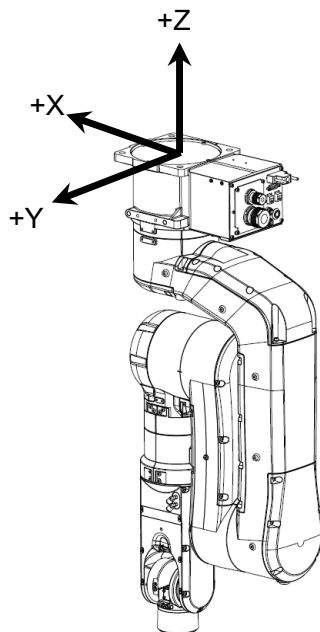

5.4 How to Use Orientation Flag

N6-A1000**

As shown in the following examples, N6-A1000** can move to the same position with the different orientation flag (Above, Below).

Ex 1

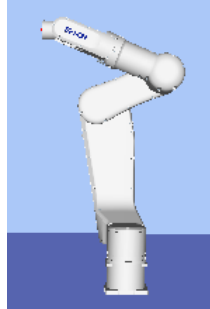

Above

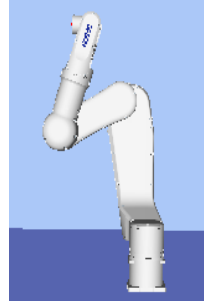

Below

Ex 2

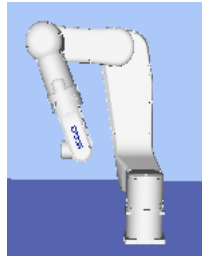

Above

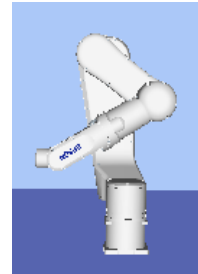

Below

When the improper orientation flag is selected, the robot may collide with the equipment. Be sure to select the proper orientation flag for your equipment.

Ex 3

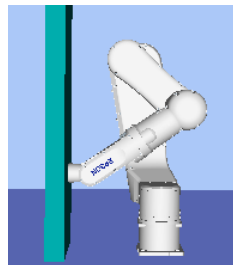

Orientation which the robot does not collide with the equipment

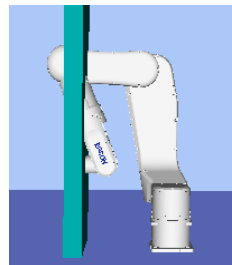

Orientation which the robot collides with the equipment

When you cannot select the orientation flag for N6-A1000**, use the command: "AutoOrientationFlag". Orientation flag is automatically changed to the orientation which the robot does not collide with the equipment.

Command: “AutoOrientationFlag”

Command: “AutoOrientationFlag” changes the orientation flag of N6-A1000** to the orientation which the robot does not collide with the equipment.

Change the following orientation flag:

Model	Parameter OFF/ON	Orientation flag			Remark
		Hand	Elbow	Wrist	
N6-A1000**	OFF	-	-	-	Move with the orientation flag which is selected by user. (Default)
	ON	-	✓	✓ *1	Set “ON” when you cannot select the orientation flag.

✓: When setting the AutoOrientationFlag to “ON”, the orientation flag is changed

*1: Wrist orientation flag is changed only when you change the elbow orientation flag. When you change the wrist orientation flag, it will be the orientation flag which minimizes the movement of Joint #4.

How to use the command

Syntax

- (1) AutoOrientationFlag On | Off
- (2) AutoOrientationFlag

Example

```
Motor On
Power High
AutoOrientationFlag On

Go P1
Go P2
```

Use AutoOrientationFlag with LJM Function

When you use the command with LJM Function, Wrist Flag, J4Flag, and J6Flag will be the orientation selected by LJM Function.

For example, when you set orientationFlag of LJM Function to “3”, “Wrist Flag”, “J4Flag”, and “J6Flag” are selected so that Joint #5 will be the shortest movement. When you do not use LJM Function, “Wrist Flag”, “J4Flag”, and “J6Flag” are selected so that Joint #4 will be the shortest movement.



When setting the AutoOrientationFlag to “ON”: Flag is changed as follows due to the position of point P and the red line.

- Point P is above the red line: Above
- Point P is below the red line: Below

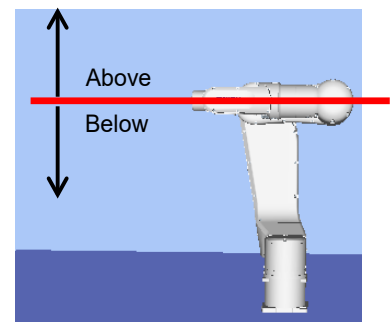

5.5 Changing the Robot

This section describes how to change the Manipulator model on Epson RC+.
 (N6-A1000** is set to “Table top mounting” by default. If you want to change the mounting type to “Ceiling mounting”, follow the steps below to change the model.
 N6-A850**R is set to “Ceiling mounting” and “Table top mounting” is not available.)



CAUTION

- Changing the Manipulator should be done with great caution. It initializes the robot calibration parameters (Hofs, CalPIs), additional axis information, and PG parameter data. Before changing the robot, make sure to save the calibration data by following the procedure below.
 1. Select the Epson RC+ menu-[Setup]-[System Configuration].
 2. Select [Controller]-[Robots]-[Robot**]-[Calibration] from the tree list. Then, click <Save>.

(1) Select the Epson RC+ menu-[Setup]-[System Configuration].

(2) Select [Controller]-[Robots]-[Robot**] from the tree list.

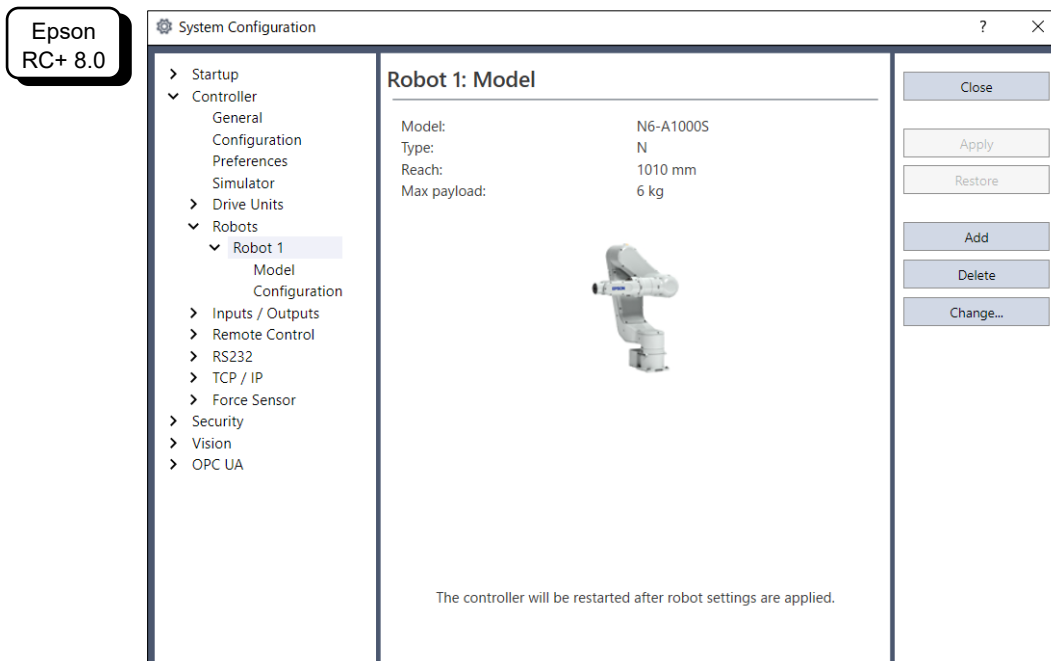
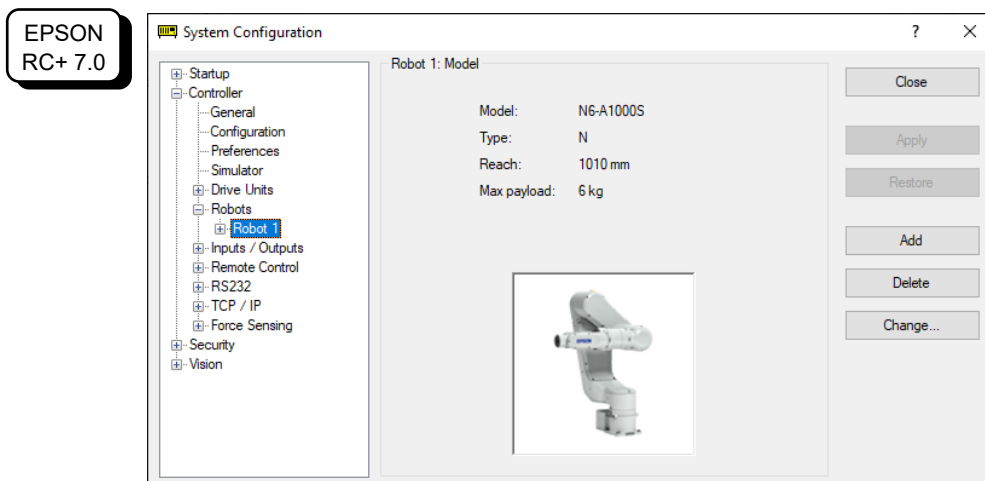

(3) Click the <Change...> button. The following dialog box will be displayed.

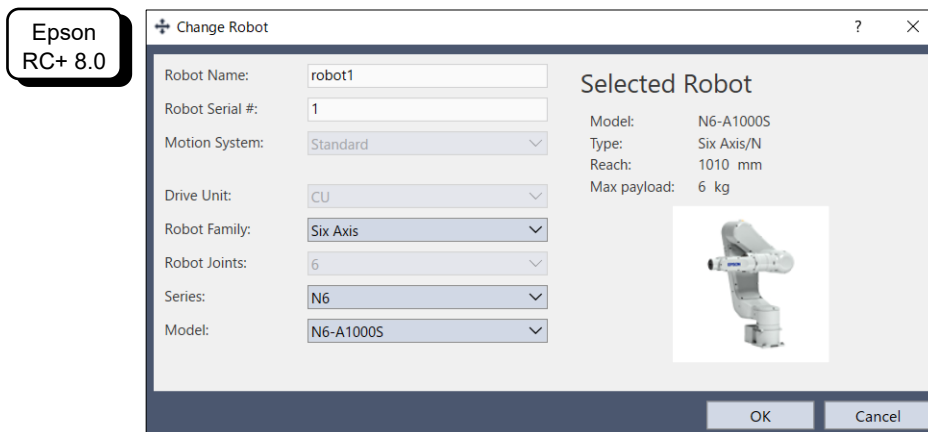
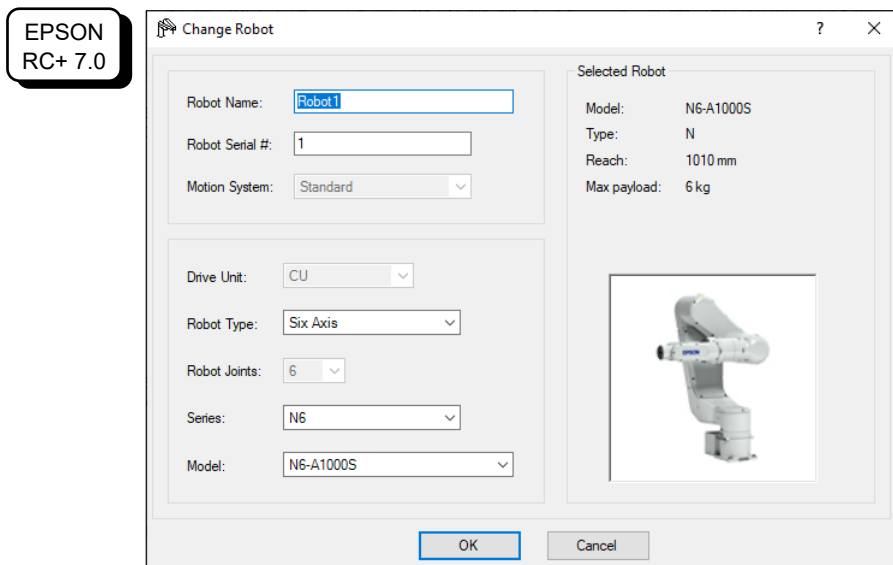

- (4) Input the robot name and serial number printed on the Label of the Manipulator.
- (5) Select the robot type in the [Robot Family] box.
- (6) Select the series name of the Manipulator in the [Series] box.
- (7) Select the robot model in the [Model] box. Available robots will be displayed according to the format of the currently installed motor driver. When [Dry run] is used, all the Manipulators of the series selected in Step 6 will be displayed.
- (8) Click the <OK> button. The Controller will be restarted.

5.6 Setting the Cartesian (Rectangular) Range in the XY Coordinate System of the Manipulator

The Cartesian (rectangular) range in the XY coordinate system of the Manipulator is specified by the limited Manipulator operation area and the XYLim setting.

The limited Manipulator operation area is defined so that the end effector does not interfere with the rear side of the Manipulator. The XYLim setting that you can determine the upper and lower limits of the X and Y coordinates.

The limited Manipulator operation area and the XYLim setting apply only to the software. Therefore, these settings do not change the physical range. The maximum physical range is

based on the position of the pulse range.

These settings are disabled during a joint jogging operation. Therefore, be careful not to allow the end effector to collide with the Manipulator or peripheral equipment.

Epson
RC+

Set the XYLim setting in [Tools]-[Robot manager]-[XYZ Limits] panel.
You may also execute the XYLim command from the [Command Window].

6. Options

N6 series Manipulator has the following options.

- 6.1 Brake Release Unit
- 6.2 Camera Plate Unit
- 6.3 Tool Adapter (ISO flange)
- 6.4 User Wiring
- 6.5 M/C cable

6.1 Brake Release Unit

With the Electromagnetic brakes are ON (such as in Emergency Stop status), all arms except for the Arm #1 cannot be moved by hand.

You can move the Arms by hand using the brake release unit while the controller power is OFF or right after unpacking.

 WARNING	<ul style="list-style-type: none"> ■ When connecting / replacing the brake release unit or the external short connector, turn OFF the power to the Controller and the brake release unit. Connecting and disconnecting the connector while the power is ON may result in electrical shock.
--	---

 CAUTION	<ul style="list-style-type: none"> ■ Normally, release the brake of joints one by one. Take extra care if you need to release the brakes of two or more joints simultaneously. Releasing the brakes of two or more joints simultaneously may cause hands and fingers to be caught and/or equipment damage to or malfunction of the Manipulator as the arms of the Manipulator may move in unexpected directions. ■ Be careful of the arm falling when releasing the brake. While the brake is being released, the Manipulator's arm falls by its own weight. The arm falling may cause hands and fingers to be caught and/or may cause equipment damage to or malfunction of the Manipulator.
--	---

Width	180 mm
Depth	150 mm
Height	87 mm
Weight (Cables are not included.)	1.7 kg
Cable to the Manipulator	2 m
M/C Short connector	For M/C power cable short-circuit

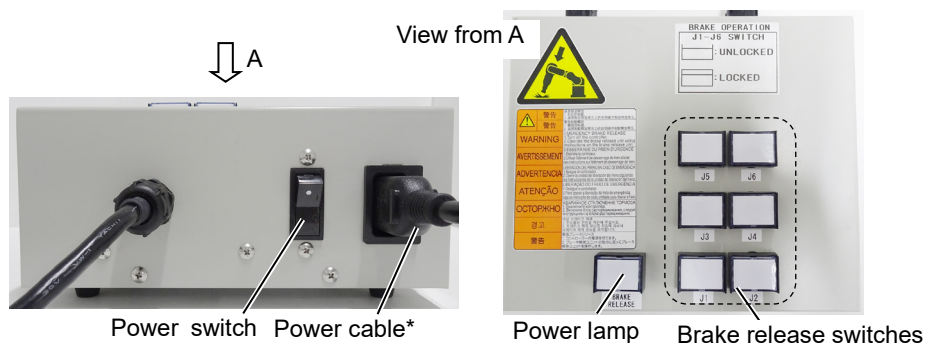

* Item you should provide

Power Cable

You must provide a power cable.

The power cable is required to meet the specifications below.

Item	Specification
(1) Plug	Comply with local safety regulation - Class I (2P+PE), AC250V, 6A or 10A Ex.: CEE Pub.7 Certified, CCC Certified, KC Certified, BS1363 Certified, PSB Certified, BIS Certified, SABS Certified - Class I (2P+PE), AC125V, 7A or 12A or, 15A etc. Ex.: UL Certified, PSE Certified, BSMI Certified
(2) Flexible cable	Comply with IEC/EN standards or local safety regulation Ex.: IEC 60227-1 General requirements IEC 60227-5 Polyvinyl chloride insulated cables of rated voltages up to and including 450/750 V - Part 5: Flexible cables (cords) EN 50525-1 General requirements EN 50525-2-11 Electric cables - Low voltage energy cables of rated voltages up to and including 450/750 V (Uo/U) - Part 2-11: Cables for general applications - Flexible cables with thermoplastic PVC insulation
(3) Appliance coupler	Comply with IEC/EN standards or local Safety regulation - IEC / EN 60320-1: Appliance couplers for household and similar general purposes - Part 1: General requirements - Standard Sheet C13: AC250V / 10A

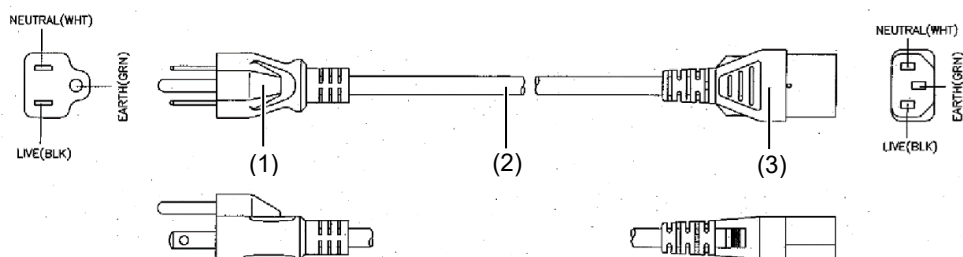

For Japan

Item	Specification
Plug	PSE Certified Class I (2P+PE), AC125V, 7A or higher
Code	PSE Certified 0.75mm ² or larger
Connector	PSE Certified IEC 60320-1 Standard Sheet C13: AC125V/10A or higher

Precautions for use



- If the Manipulator is operated without connecting the brake release unit and the external short connector, the brakes cannot be released and it may cause damage on them. After using the brake release unit, be sure to connect the external short connector to the Manipulator, or check connection of the connector for the brake release unit.
- Keep the external short connector. Otherwise you cannot release the brakes.
- If you turn ON the brake release unit while the brake release switch is being pressed, an unintended arm may move downward. Before turning ON the brake release unit, make sure that the brake release switch is not pressed.
- If you turn ON the brake release unit without the connector, it may lead to the short for the male pin used in the connector. Before turning ON the brake release unit, make sure that the connector is connected.

Mount the brake release unit

- (1) Turn OFF the controller.
- (2) When the M/C power cable is not connected to the Controller:
 - Connect either the M/C short connector or the Controller.
 - (Keep the Controller power OFF)
 - The M/C short connector can be purchased singly.

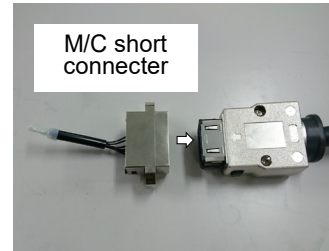

When the M/C power cable is already connected to the Controller:
Go to the step (3).



- (3) Disconnect the external short connector.
M/C cable direction: Standard (backward)

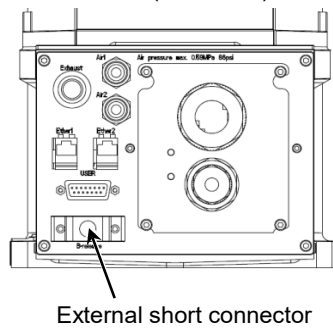

Upward and downward

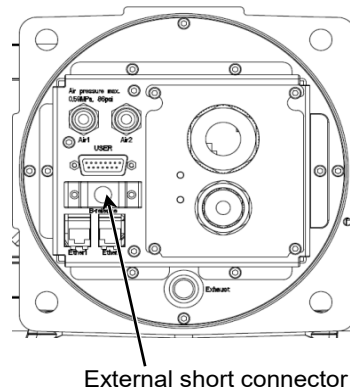

- (4) Connect the brake release unit to the connector of the connection cable.



NOTE The connection cable connector and the adjacent user cable connector have the same shape. Be careful not to connect the wrong connector.

M/C cable direction: Standard (backward)

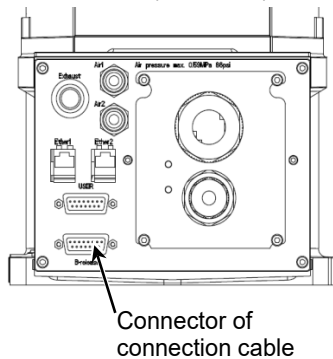

Upward and downward

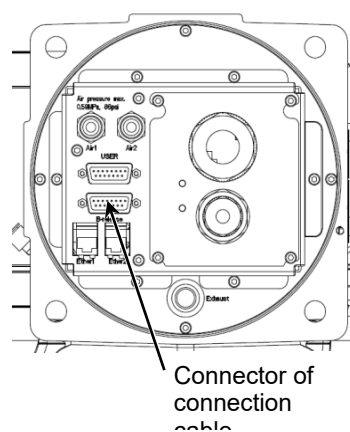

Remove the brake release unit

- (1) Turn OFF the brake release unit.
- (2) Disconnect the power cable of the brake release unit.
- (3) Disconnect the brake release unit from the connector of the connection cable.
- (4) If the M/C short connector is connected to the M/C power cable in the Installation step (2), disconnect the M/C short connector.
- (5) Connect the external short connector to the connector of the connection cable



The connection cable connector and the adjacent user cable connector have the same shape. Be careful not to connect the wrong connector.

M/C cable direction: Standard (backward)

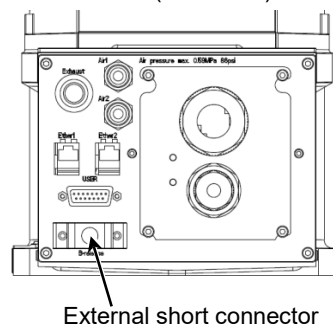

Upward and downward

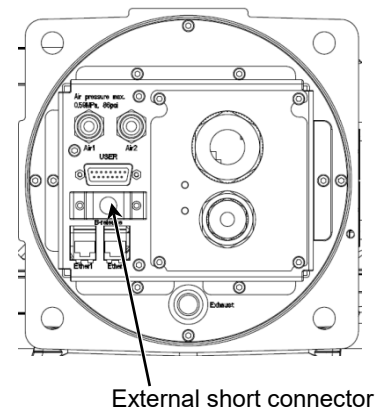

How to use the brake release unit



CAUTION

- Be careful of the arm falling when releasing the brake. While the brake is being released, the Manipulator's arm falls by its own weight. The arm falling may cause hands and fingers to be caught and/or may cause equipment damage to or malfunction of the Manipulator.
- If the arm you released its brake moves awkwardly or faster than usual, stop the operation promptly and contact the supplier of your region. The brake release unit may be broken. If you keep operating the Manipulator, it may lead to the breakdown of the Manipulator or you may get your hand or fingers caught.

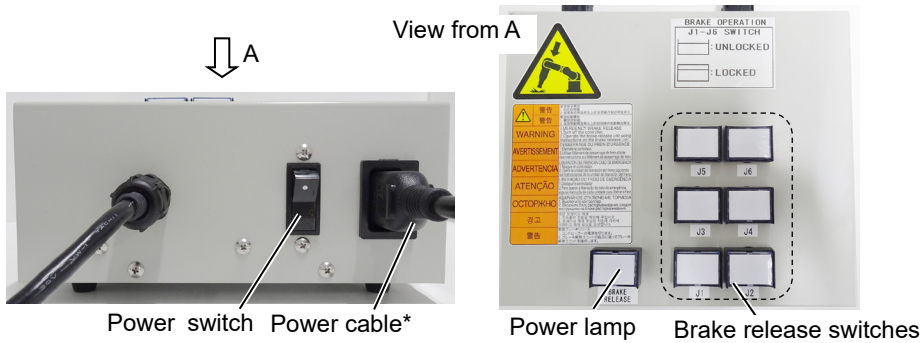

* Item you should provide

- (1) Refer to “Mount the brake release unit” above to connect the brake release unit to the connector of the connection cable.
- (2) Connect the power cable to the brake release unit.
- (3) Connect the power cable to the power supply plug.
- (4) Turn ON the brake release unit.
When the brake release unit is enabled, the power lamp lights up.
- (5) Press the switch of the arm (J2 to J6) you want to move and then move the arm.
Press the switch again. The brake will be released.
The brake will be enabled by pressing the switch once again.

NOTE Move the arm the brake is released by two persons or more (one presses the switch and one moves the arm). The arm can be very heavy and needs the significant force to move.

6.2 Camera Plate Unit

By using the camera plate unit, you can mount the camera to the N6 series Manipulator.

Appearance of arm end with camera

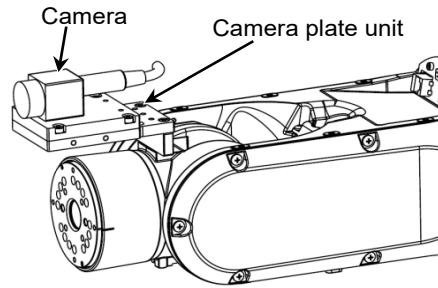

Parts included		unit
A	Camera adapter plate	1
B	Camera mid plate	1
C	Camera base plate	1
D	Hexagon socket head screws M4×12	6
E	Hexagon socket head screws M4×20	2
F	Plain washer for M4 (small washer)	2

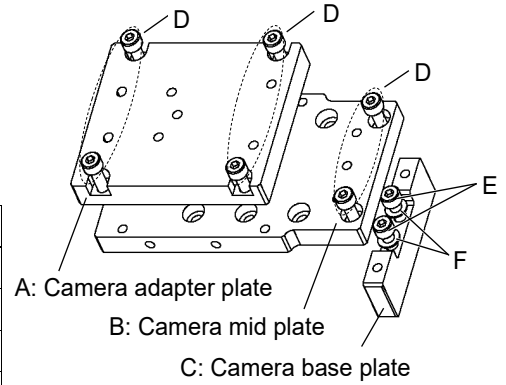

Installation

NOTE For details of tightening the hexagon socket head screws, refer to “Regular Inspection for N6 Manipulator”-“2.4 Tightening Hexagon Socket Head Bolts”.

Mounting holes for the camera base plate on the N6 series Manipulator

Camera base plate mounting hole

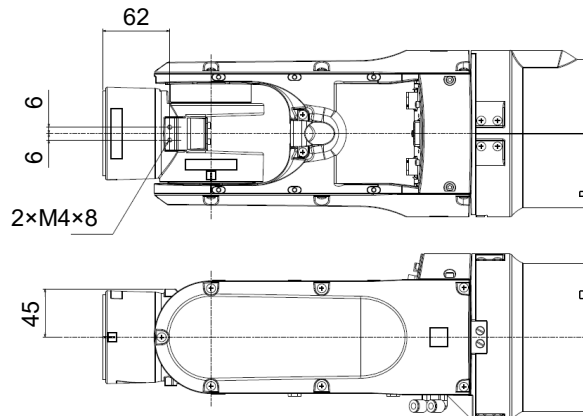
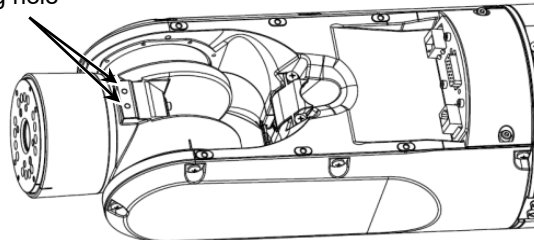

For the installation steps, refer to the following manual:

*Epson RC+ Option Vision Guide Hardware & Setup
Hardware - 6-Axis Robot*

Dimension of the camera plate unit

Dimensions X and Y vary depending on the position of the camera mid plate and camera size. Refer to the table below for the values.

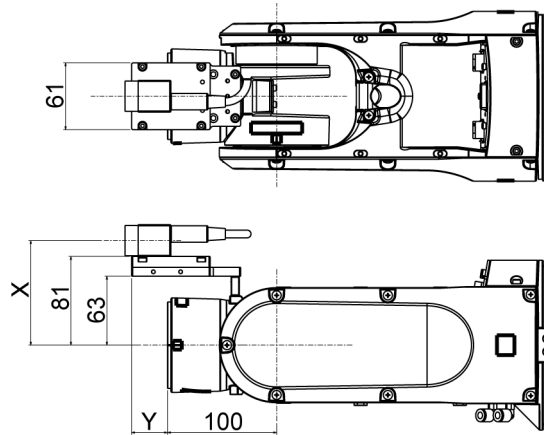

Camera adapter plate

Mounting holes to be used are different depending on the camera.

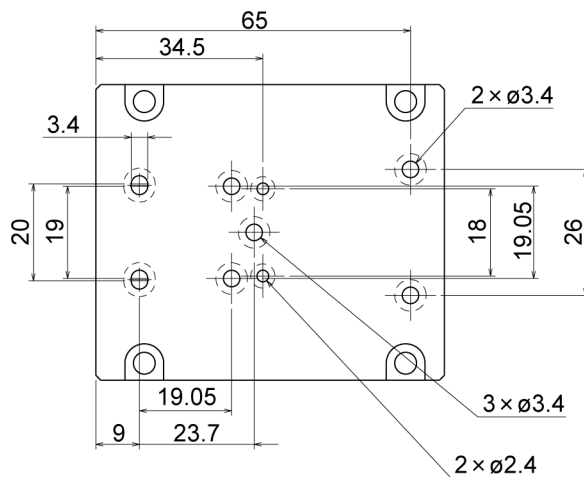

Camera mid plate

The camera mid plate uses the mounting holes A to D. By using the different mounting holes, it can be mounted to the camera base plate in the different four positions.

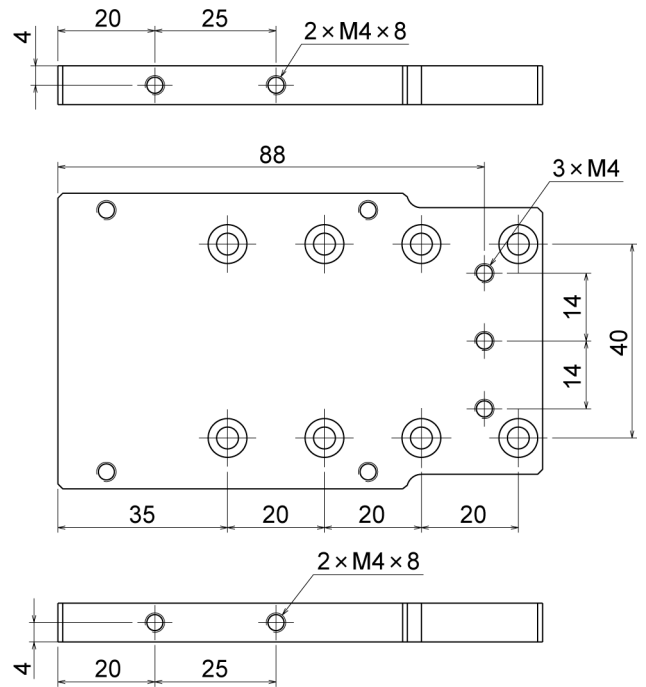

Camera and N6 series Manipulator Joint #5 motion range (reference values)

	A	B	C	D	X
USB camera, GigE camera	-75° to +125°	-65° to +125°	-55° to +125°	-45° to +125°	95.5 mm

	A	B	C	D
Y	33 mm	13 mm	-7 mm	-27 mm

The Joint #5 motion range varies depending on the mounting position of camera mid plate and the camera you are using.

The table below shows the motion range (reference values) based on the available cameras for this option and the mounting positions of the camera mid plate. The values in the table may vary depending on how to secure the cables.

Direction of the Joint #5 motion

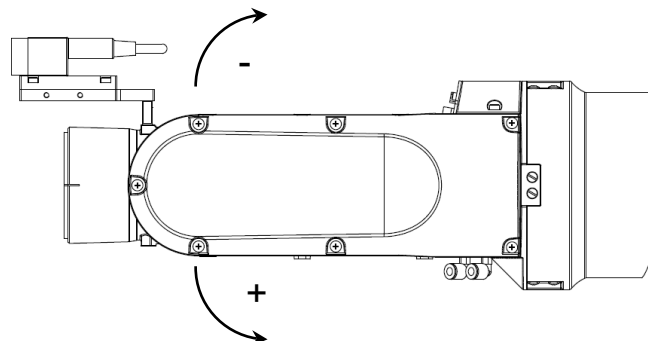

6.4 User Wiring

Use the following options when using the internal wiring for the end effector drive.

Standard user connector kit (D-sub)

Item	Qty.	Manufacturer	Standard
Connector	2	JAE	DA-15PF-N (Solder type)
Clamp hood	2	HRS	HDA-CTH(4-40)(10) (Connector setscrew: #4-40 UNC)

6.5 M/C Cable

M/C cable is a cable that connects the Manipulator and the controller.

Item	Qty.
M/C cable	1
Hexagon socket head cap bolts: M4×8	4

One type of M/C cable is included to the Manipulator at the time of shipment.

You can purchase it additionally.

When purchasing, you can select the M/C cable from the following combinations

Cable type

Cable length

Connector shape (controller connection side)

Cable type	Length	Connector shape	Code	
Default	3m	Straight	R12NZ900YF	
		L-shaped	R12NZ900YM	
	5m	Straight	R12NZ900YH	
		L-shaped	R12NZ900YN	
	10m	Straight	R12NZ900YJ	
		L-shaped	R12NZ900YP	
	15m	Straight	R12NZ900YK	
		L-shaped	R12NZ900YQ	
	20m	Straight	R12NZ900YL	
		L-shaped	R12NZ900YR	
	Flexible	3m	Straight	R12NZ900YT
			L-shaped	R12NZ900YY
5m		Straight	R12NZ900YU	
		L-shaped	R12NZ900YZ	
10m		Straight	R12NZ900YV	
		L-shaped	R12NZ900Z1	
15m		Straight	R12NZ900YW	
		L-shaped	R12NZ900Z2	
20m		Straight	R12NZ900YX	
		L-shaped	R12NZ900Z3	

For the replacement of M/C cable, refer to *N series Maintenance Manual* “N6 Maintenance - Replacing the M/C Cable”

Regular Inspection

Performing inspection properly is essential to prevent trouble and ensure safety.
This volume describes the inspection schedule and contents.
Inspect according to the schedule.

1. Regular Inspection for N2 Manipulator

This chapter describes maintenance inspection procedures. Performing maintenance inspection properly is essential to prevent trouble and ensure safety.

Be sure to perform the maintenance inspections in accordance with the schedule.

1.1 Inspection

1.1.1 Schedule for Inspection

Inspection points are divided into five stages: daily, monthly, quarterly, biannual, and annual. The inspection points are added every stage.

If the Manipulator is operated for 250 hours or longer per month, the inspection points must be added every 250 hours, 750 hours, 1500 hours, and 3000 hours operation.

	Inspection Point					
	Daily inspection	Monthly inspection	Quarterly inspection	Biannual inspection	Annual inspection	Overhaul*
1 month (250 h)	Inspect every day	√				
2 months (500 h)		√				
3 months (750 h)		√	√			
4 months (1000 h)		√				
5 months (1250 h)		√				
6 months (1500 h)		√	√	√		
7 months (1750 h)		√				
8 months (2000 h)		√				
9 months (2250 h)		√	√			
10 months (2500 h)		√				
11 months (2750 h)		√				
12 months (3000 h)		√	√	√	√	
13 months (3250 h)		√				
⋮	⋮	⋮	⋮	⋮	⋮	⋮
20000 h						√

h = hour

*Overhaul (parts replacement)

1.1.2 Inspection Point

Inspection Item

Inspection Point	Inspection Place	Daily	Monthly	Quarterly	Biannual	Annual
Check looseness or backlash of bolts/screws.	End effector mounting bolts	√	√	√	√	√
	Manipulator mounting bolts	√	√	√	√	√
Check looseness of connectors.	External connectors on Manipulator (on the connector plates etc.)	√	√	√	√	√
Visually check for external defects. Clean up if necessary.	External appearance of Manipulator	√	√	√	√	√
	External cables		√	√	√	√
Check for bends or improper location. Repair or place it properly if necessary.	Safeguard etc.	√	√	√	√	√
Check the brake operation.	Brake for Arm #2 to #6	√	√	√	√	√
Check whether unusual sound or vibration occurs.	Whole	√	√	√	√	√
Check the leak of grease for cables.	Grease for Arm #1 to #4	√	√			
Check either the external short connector or the brake release unit connector is connected.	The external short connector on the back side of the Manipulator, or the brake release unit connector.	√	√	√	√	√

Inspection Method

Inspection Point	Inspection Method
Check looseness or backlash of bolts/screws.	Use a hexagonal wrench to check that the end effector mounting bolts and the Manipulator mounting bolts are not loose. When the bolts are loose, refer to "1.4 Tightening Hexagon Socket Head Bolts" and tighten them to the proper torque.
Check looseness of connectors.	Check that connectors are not loose. When the connectors are loose, reattach it not to come off.
Visually check for external defects. Clean up if necessary.	Check the appearance of the Manipulator and clean up if necessary. Check the appearance of the cable, and if it is scratched, check that there is no cable disconnection.
Check for bends or improper location. Repair or place it properly if necessary.	Check that the safeguard, etc. are located properly. If the location is improper, place it properly.
Check the brake operation.	Check that the arm does not fall when in MOTOR OFF. If the arm falls when in MOTOR OFF and the brake is not released, contact the supplier.
Check whether unusual sound or vibration occurs.	Check that there is no unusual sound or vibration when operating. If there is something wrong, contact the supplier.

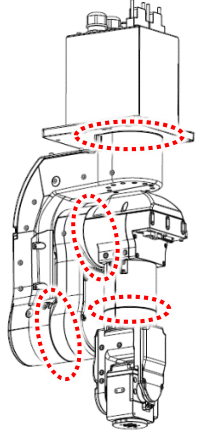
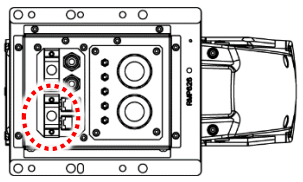
Inspection Point	Inspection Method
<p>Check the leak of grease for cables.</p>	<p>When the grease for cables is leaked from the gap of the Arm #1 to #4, wipe off the leaked grease.</p> 
<p>Check either the external short connector or the brake release unit connector is connected.</p>	<p>Check that either the external short connector or the brake release unit connector is connected. When it is not connected, connect it.</p> 

1.2 Overhaul (Parts Replacement)

Overhaul (replacement) shall be performed by personnel who has taken a proper training. For details, refer to “*Safety Manual Training*”.

1.3 Greasing

The reduction gear units and bevel gear need greasing regularly.

	Part	Interval	How to grease
Joint #1, 2, 3, 4, 5, 6	Actuator unit, Reduction gear unit	Overhaul timing	Greasing shall be performed by personnel who has taken a proper training. For details, “N series Maintenance Manual”

1.4 Tightening Hexagon Socket Head Bolts

Hexagon socket head cap bolts (hereinafter, “bolts”) are used in places where mechanical strength is required. These bolts are fastened with the tightening torque shown in the following tables.

When it is required to refasten the bolts in some procedures in this manual (except special cases as noted), use a torque wrench so that the bolts are fastened with appropriate tightening torque as shown below.

Bolt	Tightening Torque
M2.5	1.4 ± 0.1 N·m (14 ± 1 kgf·cm)
M3	2.0 ± 0.1 N·m (21 ± 1 kgf·cm)
M4	4.0 ± 0.2 N·m (41 ± 2 kgf·cm)
M5	8.0 ± 0.4 N·m (82 ± 4 kgf·cm)
M6	13.0 ± 0.6 N·m (133 ± 6 kgf·cm)
M8	32.0 ± 1.6 N·m (326 ± 16 kgf·cm)
M10	58.0 ± 2.9 N·m (590 ± 30 kgf·cm)
M12	100.0 ± 5.0 N·m (1,020 ± 51 kgf·cm)

See below for the set screw.

Set Screw	Tightening Torque
M3	0.9 ± 0.1 N·m (9 ± 1 kgf·cm)
M4	2.4 ± 0.1 N·m (26 ± 1 kgf·cm)
M5	3.9 ± 0.2 N·m (40 ± 2 kgf·cm)
M6	8.0 ± 0.4 N·m (82 ± 4 kgf·cm)

It is recommended to fasten the bolts aligned on a circumference in a crisscross pattern as shown in the figure below.

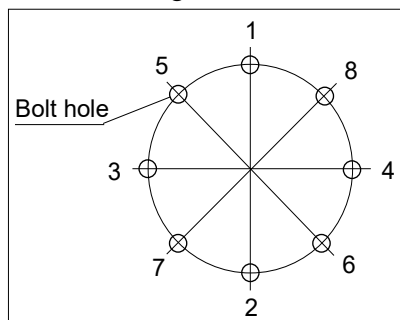

Do not fasten all bolts securely at one time. Divide the number of times to fasten the bolts into two or three and fasten the bolts securely with a hexagonal wrench. Then, use a torque wrench to fasten the bolts with tightening torques shown in the table above.

2. Regular Inspection for N6 Manipulator

This chapter describes maintenance inspection procedures. Performing maintenance inspection properly is essential to prevent trouble and ensure safety.

Be sure to perform the maintenance inspections in accordance with the schedule.

2.1 Inspection

2.1.1 Schedule for Inspection

Inspection points are divided into five stages: daily, monthly, quarterly, biannual, and annual. The inspection points are added every stage.

If the Manipulator is operated for 250 hours or longer per month, the inspection points must be added every 250 hours, 750 hours, 1500 hours, and 3000 hours operation.

	Inspection Point					
	Daily inspection	Monthly inspection	Quarterly inspection	Biannual inspection	Annual inspection	Overhaul*
1 month (250 h)	Inspect every day	√				
2 months (500 h)		√				
3 months (750 h)		√	√			
4 months (1000 h)		√				
5 months (1250 h)		√				
6 months (1500 h)		√	√	√		
7 months (1750 h)		√				
8 months (2000 h)		√				
9 months (2250 h)		√	√			
10 months (2500 h)		√				
11 months (2750 h)		√				
12 months (3000 h)		√	√	√	√	
13 months (3250 h)		√				
⋮	⋮	⋮	⋮	⋮	⋮	⋮
20000 h						√

h = hour

*Overhaul (parts replacement)

2.1.2 Inspection Point

Inspection Item

Inspection Point	Inspection Place	Daily	Monthly	Quarterly	Biannual	Annual
Check looseness or backlash of bolts/screws.	End effector mounting bolts	√	√	√	√	√
	Manipulator mounting bolts	√	√	√	√	√
Check looseness of connectors.	External connectors on Manipulator (on the connector plates etc.)	√	√	√	√	√
Visually check for external defects. Clean up if necessary.	External appearance of Manipulator	√	√	√	√	√
	External cables		√	√	√	√
Check for bends or improper location. Repair or place it properly if necessary.	Safeguard etc.	√	√	√	√	√
Check the brake operation.	Brake for Arm #2 to #6	√	√	√	√	√
Check whether unusual sound or vibration occurs.	Whole	√	√	√	√	√
Check the leak of grease for cables.	Grease for Arm #1 to #4	√	√			
Check either the external short connector or the brake release unit connector is connected.	The external short connector on the back side of the Manipulator, or the brake release unit connector.	√	√	√	√	√

Inspection Method

Inspection Point	Inspection Method
Check looseness or backlash of bolts/screws.	Use a hexagonal wrench to check that the end effector mounting bolts and the Manipulator mounting bolts are not loose. When the bolts are loose, refer to "2.4 Tightening Hexagon Socket Head Bolts" and tighten them to the proper torque.
Check looseness of connectors.	Check that connectors are not loose. When the connectors are loose, reattach it not to come off.
Visually check for external defects. Clean up if necessary.	Check the appearance of the Manipulator and clean up if necessary. Check the appearance of the cable, and if it is scratched, check that there is no cable disconnection.
Check for bends or improper location. Repair or place it properly if necessary.	Check that the safeguard, etc. are located properly. If the location is improper, place it properly.
Check the brake operation.	Check that the arm does not fall when in MOTOR OFF. If the arm falls when in MOTOR OFF and the brake is not released, contact the supplier.
Check whether unusual sound or vibration occurs.	Check that there is no unusual sound or vibration when operating. If there is something wrong, contact the supplier.

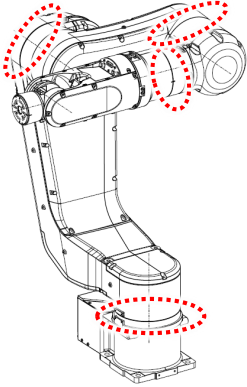
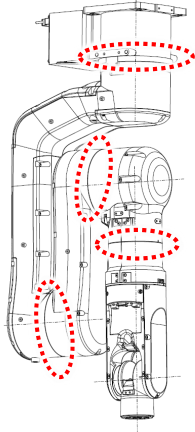
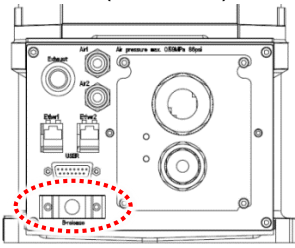
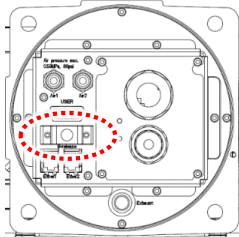
Inspection Point	Inspection Method
<p>Check the leak of grease for cables.</p>	<p>When the grease for cables is leaked from the gap of the Arm #1 to #4, wipe off the leaked grease.</p> <div style="display: flex; justify-content: space-around;"> <div data-bbox="655 331 914 779"> <p>N6-A1000**</p>  </div> <div data-bbox="1074 331 1281 824"> <p>N6-A850**</p>  </div> </div>
	<p>Check that either the external short connector or the brake release unit connector is connected.</p> <p>When it is not connected, connect it.</p> <div style="display: flex; justify-content: space-around;"> <div data-bbox="655 987 978 1305"> <p>M/C cable direction: Backward (standard)</p>  </div> <div data-bbox="1066 987 1313 1305"> <p>M/C cable direction: Upward and Downward</p>  </div> </div>

2.2 Overhaul (Parts Replacement)

Overhaul (replacement) shall be performed by personnel who has taken a proper training. For details, refer to “*Safety Manual Training*”.

2.3 Greasing

The reduction gear units and bevel gear need greasing regularly.

	Part	Interval	How to grease
Joint #1, 2, 3, 4, 5, 6	Actuator unit, Reduction gear unit	Overhaul timing	Greasing shall be performed by personnel who has taken a proper training. For details, “N series Maintenance Manual”
Joint #6	Bevel gear		

2.4 Tightening Hexagon Socket Head Bolts

Hexagon socket head cap bolts (hereinafter, “bolts”) are used in places where mechanical strength is required. These bolts are fastened with the tightening torque shown in the following tables.

When it is required to refasten the bolts in some procedures in this manual (except special cases as noted), use a torque wrench so that the bolts are fastened with appropriate tightening torque as shown below.

Bolt	Tightening Torque
M2.5	1.4 ± 0.1 N·m (14 ± 1 kgf·cm)
M3	2.0 ± 0.1 N·m (21 ± 1 kgf·cm)
M4	4.0 ± 0.2 N·m (41 ± 2 kgf·cm)
M5	8.0 ± 0.4 N·m (82 ± 4 kgf·cm)
M6	13.0 ± 0.6 N·m (133 ± 6 kgf·cm)
M8	32.0 ± 1.6 N·m (326 ± 16 kgf·cm)
M10	58.0 ± 2.9 N·m (590 ± 30 kgf·cm)
M12	100.0 ± 5.0 N·m (1,020 ± 51 kgf·cm)

See below for the set screw.

Set Screw	Tightening Torque
M3	0.9 ± 0.1 N·m (9 ± 1 kgf·cm)
M4	2.4 ± 0.1 N·m (26 ± 1 kgf·cm)
M5	3.9 ± 0.2 N·m (40 ± 2 kgf·cm)
M6	8.0 ± 0.4 N·m (82 ± 4 kgf·cm)

It is recommended to fasten the bolts aligned on a circumference in a crisscross pattern as shown in the figure below.

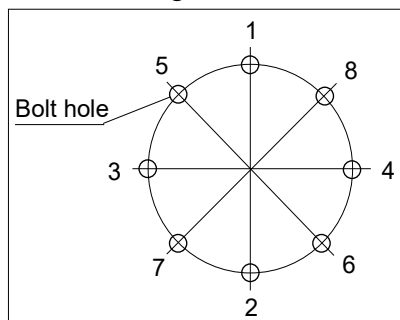

Do not fasten all bolts securely at one time. Divide the number of times to fasten the bolts into two or three and fasten the bolts securely with a hexagonal wrench. Then, use a torque wrench to fasten the bolts with tightening torques shown in the table above.

Appendix

This volume describes the specifications table for each model and detailed data of stopping time and stopping distance.

Appendix A: Specifications

N2 Specifications

Item		Specification
Model Number		N2-A450SR N2-A450S
Model Name		N2
Mounting type		Ceiling mounting Table Top mounting ^{*1}
Weight (excluding cables)		19 kg (42 lbs.)
Driving method	All joints	AC servo motor
Max. operating speed ^{*2}	Joint #1	297°/s
	Joint #2	297°/s
	Joint #3	356°/s
	Joint #4	356°/s
	Joint #5	360°/s
	Joint #6	360°/s
Maximum synthetic speed		5772 mm/s
Repeatability	Joint #1 to #6	± 0.02 mm
Max. motion range	Joint #1	± 180°
	Joint #2	± 180°
	Joint #3	± 180°
	Joint #4	± 195°
	Joint #5	± 130°
	Joint #6	± 360°
Max. pulse range	Joint #1	± 7929856 pulse
	Joint #2	± 7929856 pulse
	Joint #3	± 6619136 pulse
	Joint #4	± 7170731 pulse
	Joint #5	± 4733156 pulse
	Joint #6	± 13107200 pulse
Resolution	Joint #1	0.0000227°/pulse
	Joint #2	0.0000227°/pulse
	Joint #3	0.0000272°/pulse
	Joint #4	0.0000272°/pulse
	Joint #5	0.0000275°/pulse
	Joint #6	0.0000275°/pulse
Motor rated capacity	Joint #1	100 W
	Joint #2	100 W
	Joint #3	100 W
	Joint #4	30 W
	Joint #5	30 W
	Joint #6	15 W
Payload ^{*3}	Rated	1 kg
	Max.	2.5 kg
Allowable moment	Joint #4	5.4 N·m (0.55 kgf·m)
	Joint #5	5.4 N·m (0.55 kgf·m)
	Joint #6	2.4 N·m (0.24 kgf·m)
Allowable moment of inertia (GD2/4) ^{*4}	Joint #4	0.2 kg·m ²
	Joint #5	0.2 kg·m ²
	Joint #6	0.08 kg·m ²
Installed wire for customer use		15 wires (D-sub) 8 pin (RJ45) Cat 5e or equivalent (2 cables) (also used for Force Sensor)

Appendix A: Specifications

Item		Specification	
Model Number		N2-A450SR, N2-A450S	
Model Name		N2	
Installed pneumatic tube for customer use *5		ø6 mm pneumatic tubes (2 tubes), Allowable pressure: 0.59 MPa (6 kgf/cm ²) (86 psi)	
Environmental requirements *6	Ambient Temperature	5 to 40 °C *7	
	Ambient relative humidity	20 to 80% (no condensation)	
	Vibration	4.9 m/s ² (0.5 G) or less	
Noise level *8		LAeq = 71.2 dB (A)	
Applicable Controller		RC700-A	
MC cable	Cable weight (cable only)	For fixing and signal (common to all lengths)	0.09 kg/m
		For fixing and power (3M, 5M, 10M)	0.38 kg/m
		For fixing and power (15M, 20M)	0.43 kg/m
	Cable outer diameter	For fixing and signal (common to all lengths)	Ø7.7 mm (typ)
		For fixing and power (3M, 5M, 10M)	Ø 15.4 mm (typ)
		For fixing and power (15M, 20M)	Ø 17.4 mm (typ)
	Minimum bending radius	For fixing and signal (common to all lengths)	47 mm
		For fixing and power (3M, 5M, 10M)	93 mm
		For fixing and power (15M, 20M)	105 mm
Setting value range () Default value	SPEED	1 ~ (5) ~ 100	
	ACCEL *9	1 ~ (5) ~ 120	
	SPEEDS	0.1 ~ (50) ~ 1120	
	ACCELS	0.1 ~ (200) ~ 5000	
	FINE	0 ~ (10000) ~ 65535	
	WEIGHT	0 ~ (1) ~ 2.5	
	INERTIA	0 ~ (0.005) ~ 0.08	

*1: Manipulators are set to “Ceiling mounting” at shipment.

To use the Manipulators as “Table Top mounting”, you need to change the model settings.

Mounting types other than “Ceiling mounting” and “Table Top mounting” are out of specification.

For details on how to change the model settings, refer to “*N2 Manipulator 5.4 Changing the Robot*”, and “*Epson RC+ User’s Guide Robot Configuration*”.

*2: In case of PTP control

*3: Do not apply the load exceeding the maximum payload.

*4: If the center of gravity is at the center of each arm. If the center of gravity is not at the center of each arm, set the eccentric quantity using INERTIA command.

*5: For details of the installed pneumatic tube for customer use, refer to “*N2 Manipulator 3.7 User Wires and Pneumatic Tubes*”.

*6: For details of the environmental requirements, refer to “*N2 Manipulator 3.1 Environmental Conditions*”.

*7: When the product is used in a low temperature environment around the minimum temperature of the product specification, or when the product is suspended for a long time on holidays or at night, a collision detection error may occur due to the large resistance of the drive unit immediately after the start of operation. In such

a case, it is recommended to warm up for about 10 minutes.

*8: Conditions of Manipulator at measurement are as follows:

Operating conditions: Under rated load, 6 arms simultaneous motion, maximum speed,
maximum acceleration/deceleration, and duty 50%.

Measurement point: 1000 mm apart from the rear of Manipulator

*9: In general use, Accel setting 100 is the optimum setting that maintains the balance of acceleration and vibration when positioning. Although values larger than 100 can be set to Accel, it is recommended to minimize the use of large values to necessary motions since operating the Manipulator continuously with the large Accel setting may shorten the product life remarkably.

N6 Specifications

Item		Specification	
Model Number		N6-A1000**	N6-A850**R
Model Name		N6	
Mounting type		Ceiling mounting, Table Top mounting *1	Ceiling mounting
Weight (excluding cables)		69 kg (152 lbs.)	64 kg (141 lbs.)
Driving method		AC servo motor	
Max. operating speed *2	Joint #1	326°/s	
	Joint #2	326°/s	
	Joint #3	444°/s	
	Joint #4	444°/s	
	Joint #5	450°/s	
	Joint #6	537°/s	
Repeatability		± 0.04 mm	± 0.03 mm
Max. motion range	Joint #1	± 180°	
	Joint #2	± 180°	
	Joint #3	± 180°	
	Joint #4	± 200°	
	Joint #5	± 125°	
	Joint #6	± 360°	
Max. pulse range	Joint #1	± 6619136 pulse	
	Joint #2	± 6619136 pulse	
	Joint #3	± 5308416 pulse	
	Joint #4	± 5898240 pulse	
	Joint #5	± 3640889 pulse	
	Joint #6	± 8773632 pulse	
Resolution	Joint #1	0.0000272°/pulse	
	Joint #2	0.0000272°/pulse	
	Joint #3	0.0000339°/pulse	
	Joint #4	0.0000339°/pulse	
	Joint #5	0.0000343°/pulse	
	Joint #6	0.0000410°/pulse	
Motor rated capacity	Joint #1	600 W	
	Joint #2	600 W	
	Joint #3	400 W	
	Joint #4	100 W	
	Joint #5	100W	
	Joint #6	100W	
Payload *3	Rated	3 kg	
	Max.	6 kg	
Allowable moment	Joint #4	15.2 N·m (1.55kgf·m)	
	Joint #5	15.2 N·m (1.55kgf·m)	
	Joint #6	9.4 N·m (0.96 kgf·m)	
Allowable moment of inertia (GD2/4) *4	Joint #4	0.42 kg·m ²	
	Joint #5	0.42 kg·m ²	
	Joint #6	0.14 kg·m ²	
Installed wire for customer use		15 wires (D-sub) 8 pin (RJ45) Cat 5e or equivalent (2 cables) (also used for Force Sensor)	

Item		Specification		
Model Number		N6-A1000**	N6-A850**R	
Model Name		N6		
Installed pneumatic tube for customer use *5		ø6 mm pneumatic tubes (2 tubes), Allowable pressure: 0.59 MPa (6 kgf/cm ²) (86 psi)		
Environmental requirements *6	Ambient Temperature	5 to 40 °C *7		
	Ambient relative humidity	10 to 80% (no condensation)		
	Vibration	4.9 m/s ² (0.5 G) or less		
Noise level *8		LAeq = 76.4 dB (A)	LAeq = 70 dB (A) or under	
Environment		Standard Cleanroom & ESD *9		
Applicable Controller		RC700-A, RC700DU-A		
MC cable	Cable weight (cable only)	For fixing and signal (common to all lengths)	0.09 kg/m	
		For fixing and power (common to all lengths)	0.44 kg/m	
		For movable and signal (common to all lengths)	0.19 kg/m	
		For movable and power (common to all lengths)	0.46 kg/m	
	Cable outer diameter	For fixing and signal (common to all lengths)	Ø7.7 mm (typ)	
		For fixing and power (common to all lengths)	Ø16.9 mm (typ)	
		For movable and signal (common to all lengths)	Ø12.1 mm (typ)	
		For movable and power (common to all lengths)	Ø19.3 mm (typ)	
	Minimum bending radius *10	For fixing and signal (common to all lengths)	47 mm	
		For fixing and power (common to all lengths)	102 mm	
		For movable and signal (common to all lengths)	116 mm	
		For movable and power (common to all lengths)	116 mm	
	Setting value range () Default value	SPEED	1 ~ (3) ~ 100	
		ACCEL *11	1 ~ (5) ~ 120	
		SPEEDS	0.1 ~ (50) ~ 2000	
		ACCELS	0.1 ~ (200) ~ 25000	
FINE		0 ~ (10000) ~ 65535		
WEIGHT		0 ~ (3) ~ 6		

	INERTIA	0 ~ (0.03) ~ 0.14
--	---------	-------------------

- *1: Manipulator is set to “Table Top mounting” at shipment.
 To use the Manipulator as “Ceiling mounting”, you need to change the model settings.
 Mounting types other than “Table Top mounting” and “Ceiling mounting” are out of the specification.
 For details on how to change the model settings, refer to “*N6 Manipulator 5.5 Changing the Robot*”, and “*Epson RC+ User’s Guide Robot Configuration*”.
 - *2: In case of PTP control
 - *3: Do not apply the load exceeding the maximum payload.
 - *4: If the center of gravity is at the center of each arm. If the center of gravity is not at the center of each arm, set the eccentric quantity using INERTIA setting.
 - *5: For details of the installed pneumatic tube for customer use, refer to “*N6 Manipulator 3.7 User Wires and Pneumatic Tubes*”.
 - *6: For details of the environmental requirements, refer to “*N6 Manipulator 3.1 Environmental Conditions*”.
 - *7: When the product is used in a low temperature environment around the minimum temperature of the product specification, or when the product is suspended for a long time on holidays or at night, a collision detection error may occur due to the large resistance of the drive unit immediately after the start of operation. In such a case, it is recommended to warm up for about 10 minutes.
 - *8: Conditions of Manipulator at measurement are as follows:
 Operating conditions: Under rated load, 6 arms simultaneous motion, maximum speed, maximum acceleration/deceleration, and duty 50%.
 Measurement point: 1000 mm apart from the rear of Manipulator
 - *9: The exhaust system in the Cleanroom model Manipulator draws air from the base interior and arm cover interior. A crack or other opening in the base unit can cause loss of negative air pressure in the outer part of the arm, which can cause increased dust emission.
 Cleanliness level : Class ISO 5 (ISO14644-1)
 Exhaust System : Fitting for ø10 mm pneumatic tube
 (Reference: *N6 Manipulator 3.7 User Wires and Pneumatic Tubes*)
 60 L/min vacuum
 Exhaust tube : Polyurethane tube
 Outer diameter: ø10mm (Inner diameter: ø6-7 mm)
- ESD specification uses resin materials with antistatic treatment. This model controls adhesion of dust due to electrostatic charge.

*10: Note the following points when wiring the movable M/C cable.

- Install the cable not to apply a load to the connector.
- Bend the cable at the minimum bending radius of the movable part or more. The bending radius (a) and dimensions are shown in the figure below.

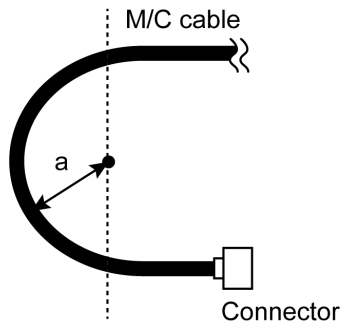

*11: In general use, Accel setting 100 is the optimum setting that maintains the balance of acceleration and vibration when positioning. Although values larger than 100 can be set to Accel, it is recommended to minimize the use of large values to necessary motions since operating the Manipulator continuously with the large Accel setting may shorten the product life remarkably.

Appendix B: Stopping time and Stopping distance in Emergency

The stopping time and stopping distance in emergency stop are shown in a graph for each model.

The stopping time is “Stopping time” in the figure below. Be sure to confirm that safety is ensured according to the installation environment and operation of the robot.

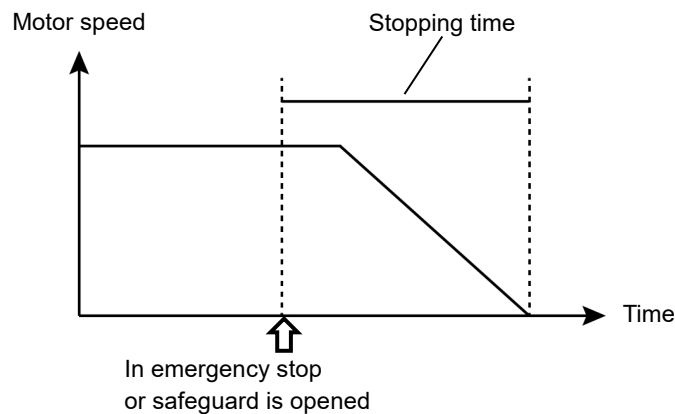

Condition:

The stopping time and stopping distance vary depending on the parameters (setting value) set for the robot. In this chapter, the time and distance are shown with the following parameters.

These conditions are based on the ISO 10218-1:2011 Annex B.

Accel : 100 ,100

Speed: 100 %, 66 %, 33 %Settings

Weight: 100 %, 66 %, 33 % of the maximum payload, rated payload

Arm elongation rate: 100 %, 66 %, 33 % *1

Other : Default

Motion: Singular axis motion of a Go command

Input timing of the Stop signal: input with maximum speed. In this motion, it is the center of the motion range.

*1 Arm elongation rate

The arm elongation rate L is as shown below:

The graphs indicate the results where the stopping time and the stopping distance in the longest among the arm elongation rates.

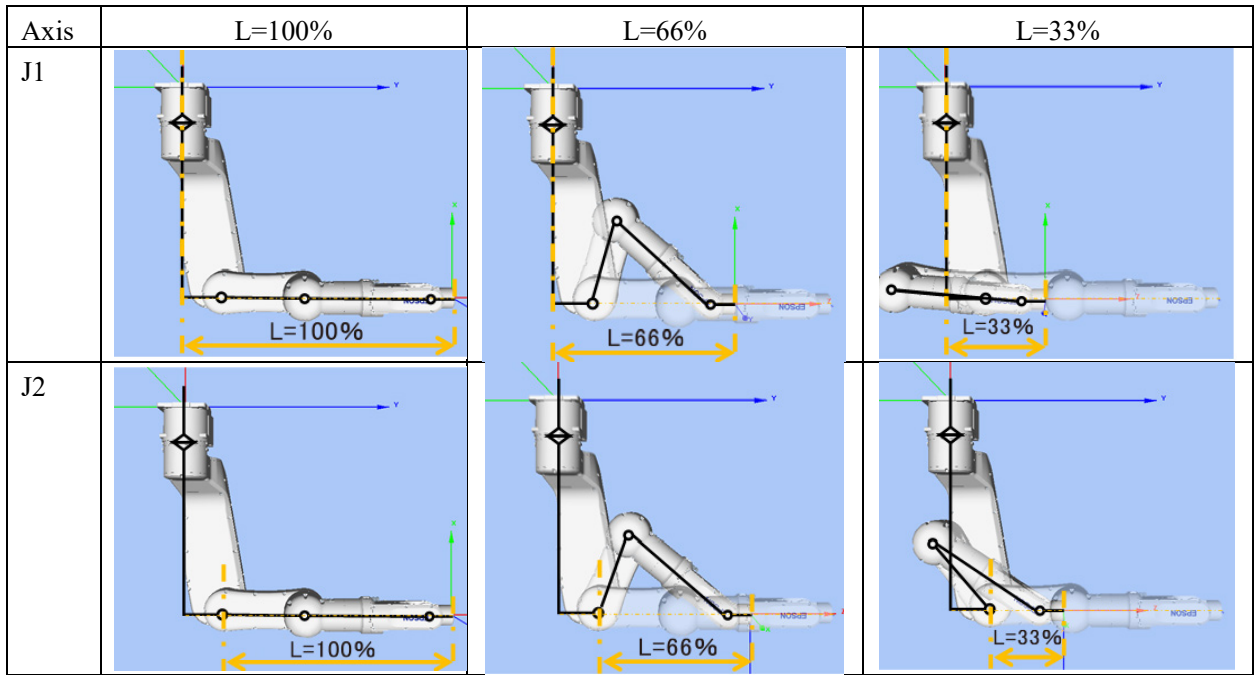

Description of legend:

The graph is shown for each Weight value(at 100%, approx. 66%, and approx. 33% of the maximum payload, and at the rated payload).

- Horizontal axis : Arm speed (Speed value)
- Vertical axis : Stopping time and stopping distance in each arm speed
- Time [sec] : Stopping time
- Distance [deg] : Stopping distance

N2 Stopping time and Stopping distance in Emergency

N2-A450S*: J1 (Table Top mounting, Ceiling mounting)

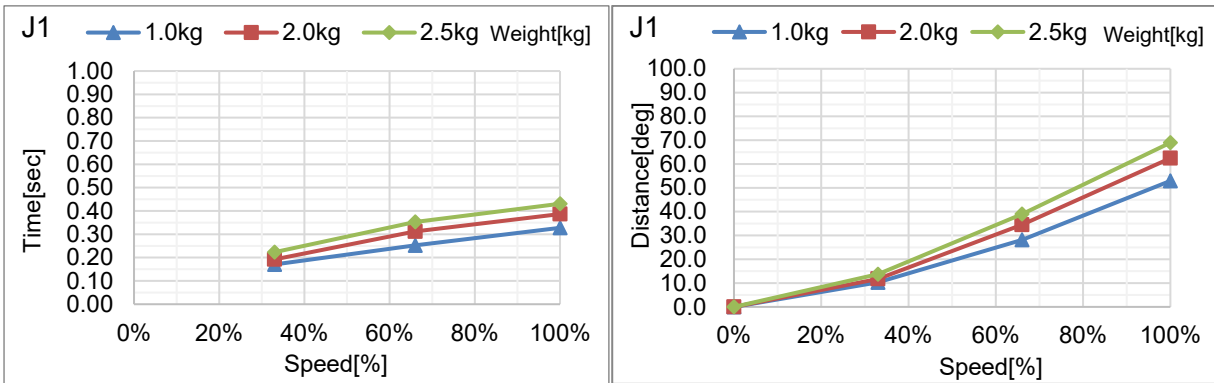

N2-A450S*: J2 (Table Top mounting, Ceiling mounting)

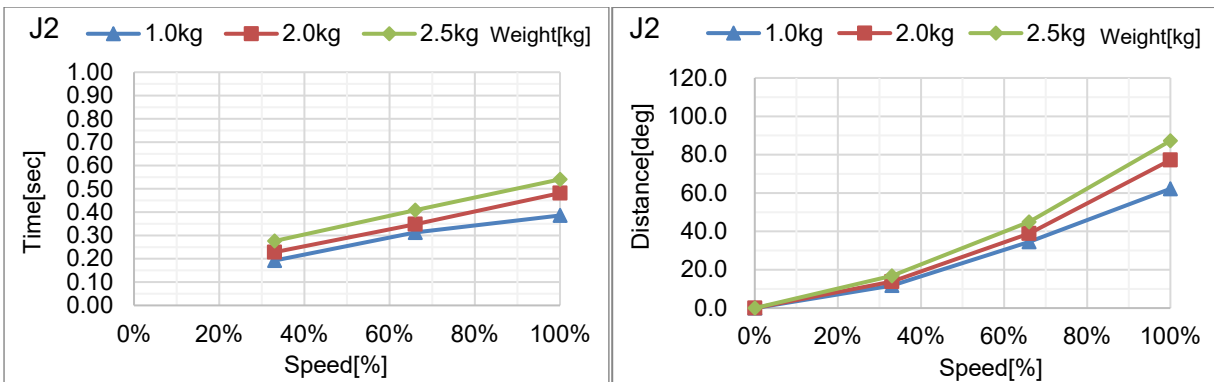

N2-A450S*: J3 (Table Top mounting, Ceiling mounting)

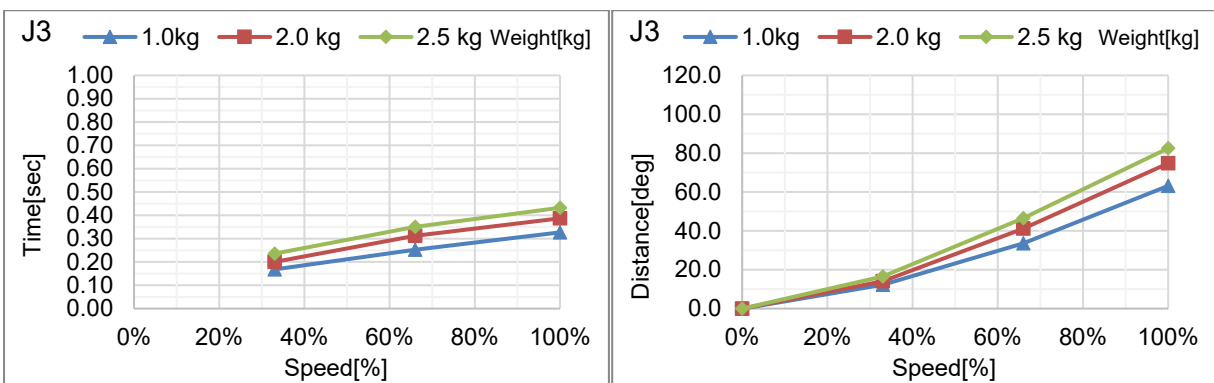

N2-A450S*: J4 (Table Top mounting, Ceiling mounting)

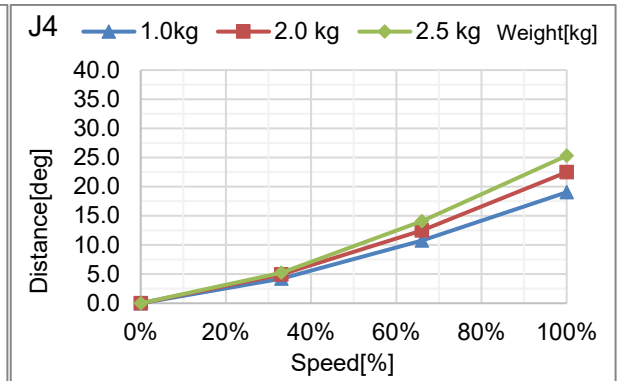
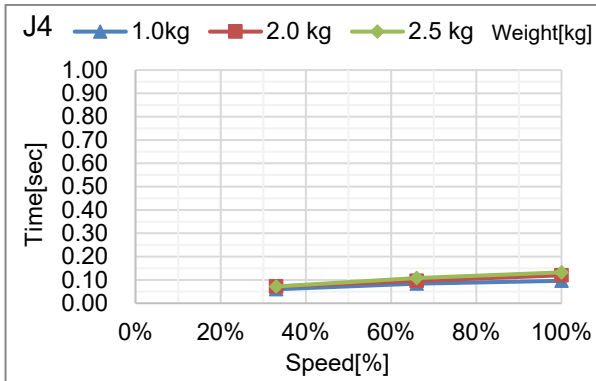

N2-A450S*: J5 (Table Top mounting, Ceiling mounting)

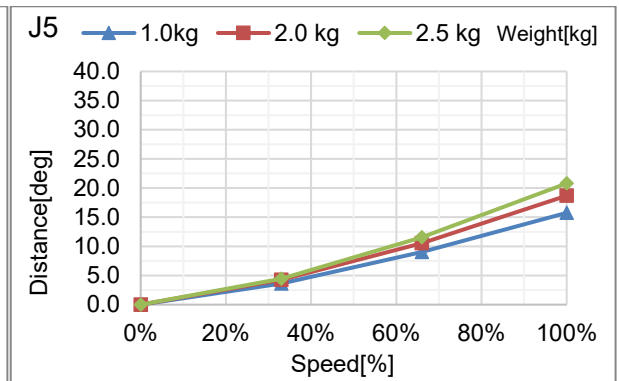
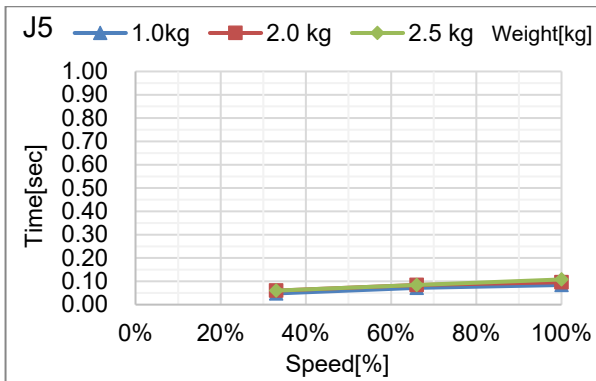

N2-A450S*: J6 (Table Top mounting, Ceiling mounting)

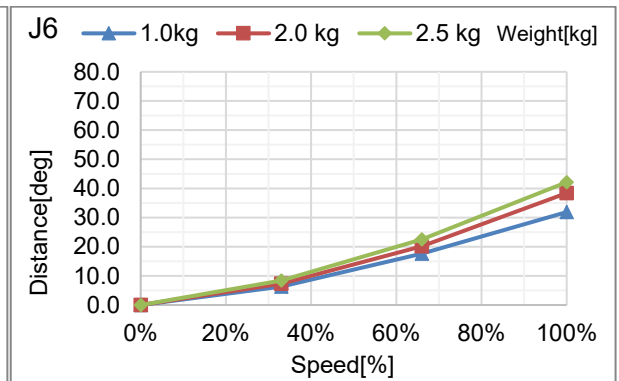
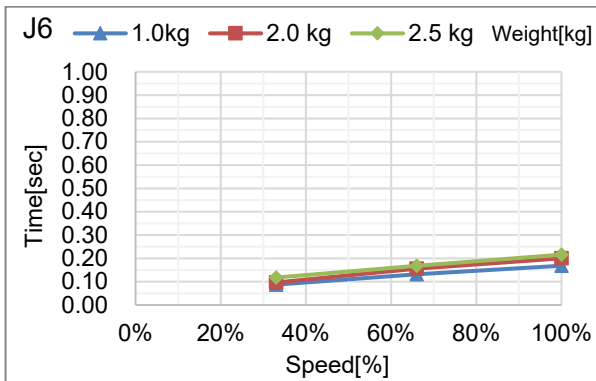

N6 Stopping time and Stopping distance in Emergency

N6-A850**R: J1 (Ceiling mounting)

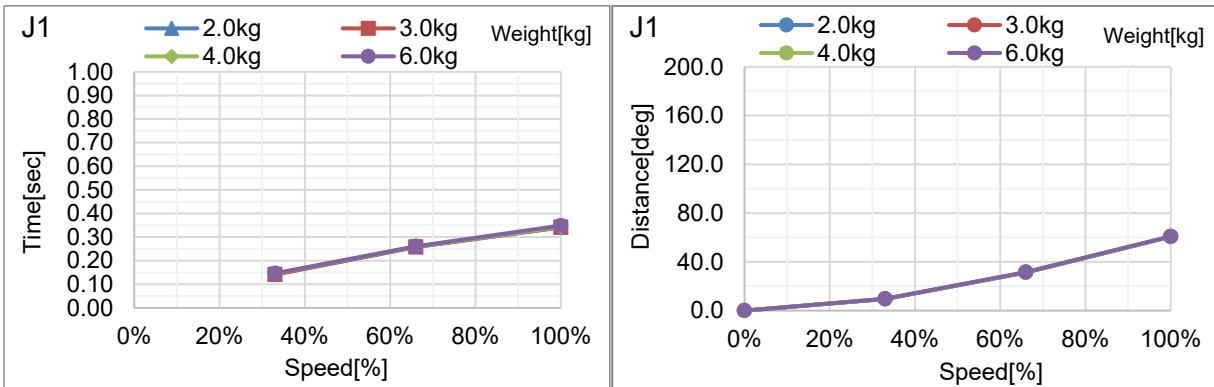

N6-A850**R: J2 (Ceiling mounting)

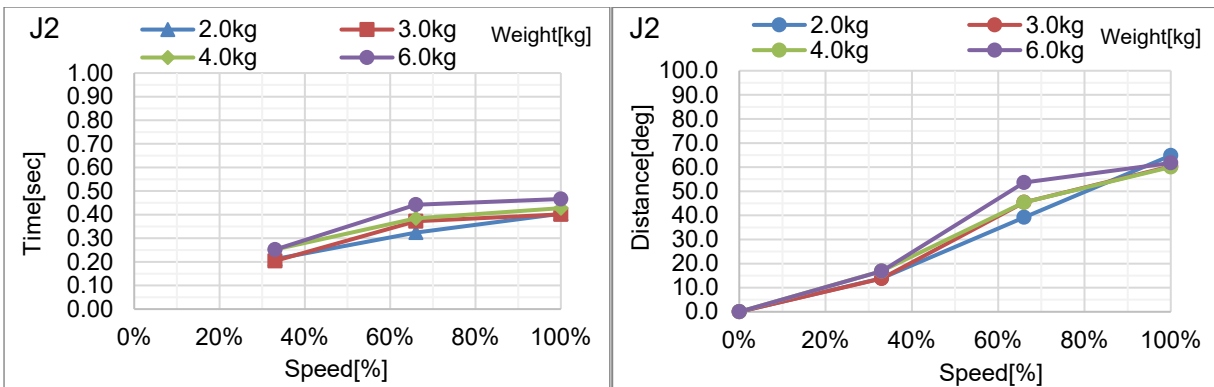

N6-A850**R: J3 (Ceiling mounting)

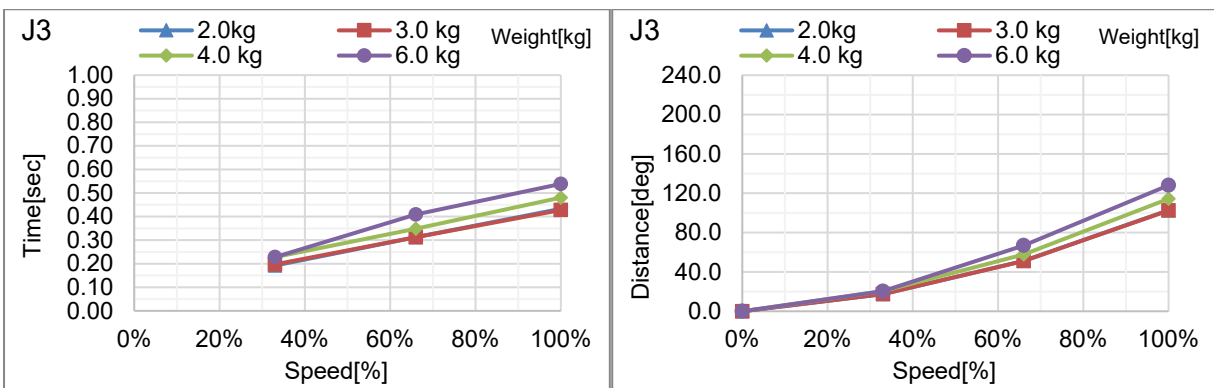

N6-A850**R: J4 (Ceiling mounting)

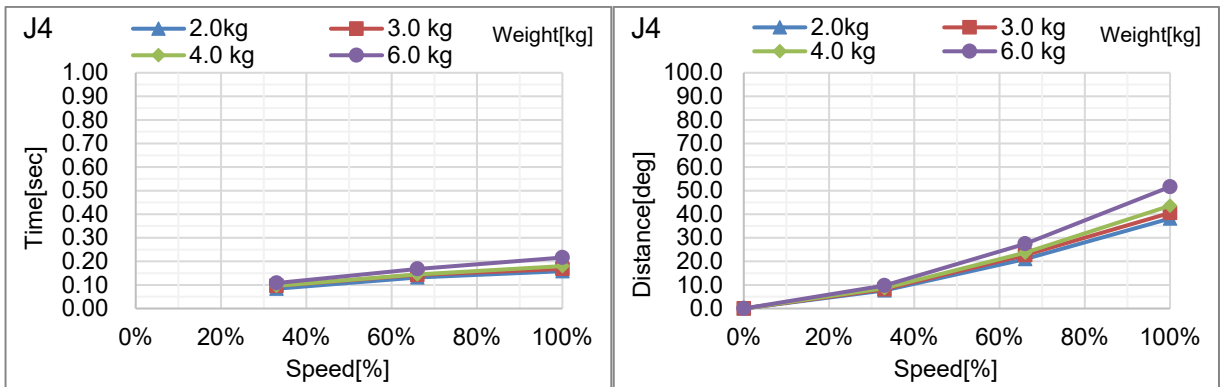

N6-A850**R: J5 (Ceiling mounting)

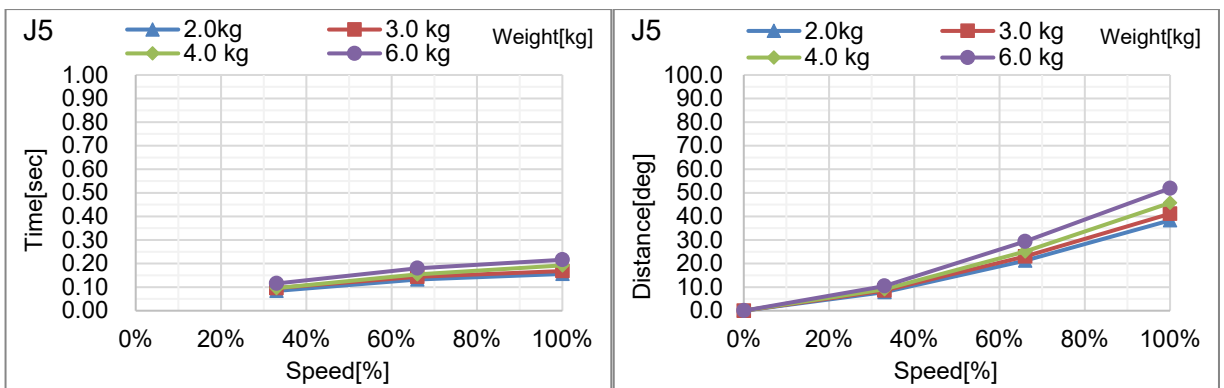

N6-A850**R: J6 (Ceiling mounting)

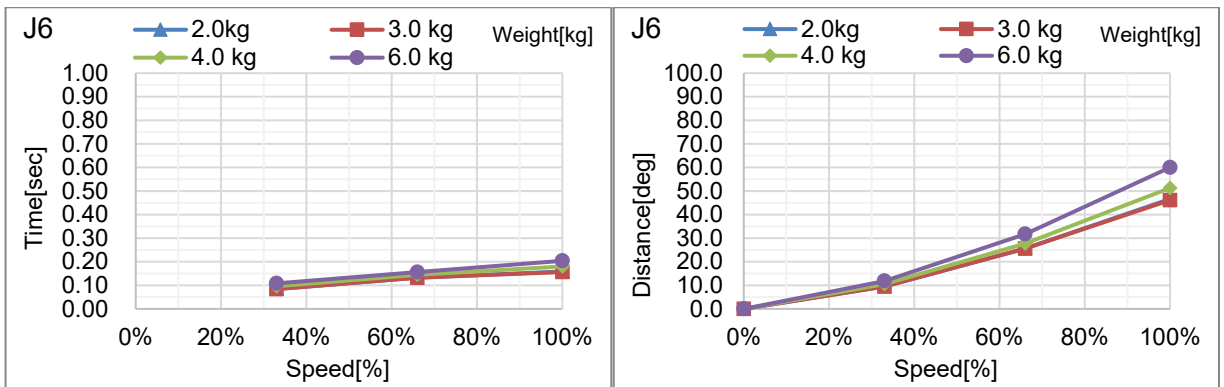

N6-A1000**: J1 (Table Top mounting, Ceiling mounting)

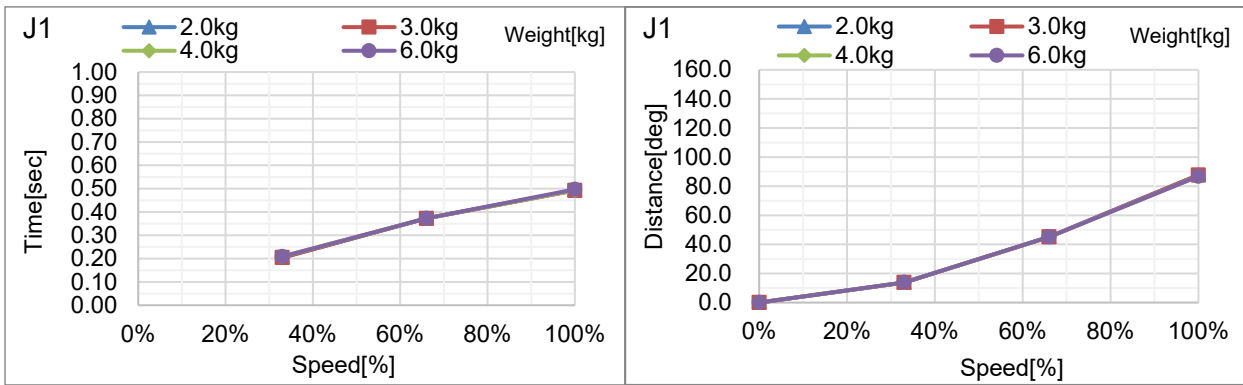

N6-A1000**: J2 (Table Top mounting, Ceiling mounting)

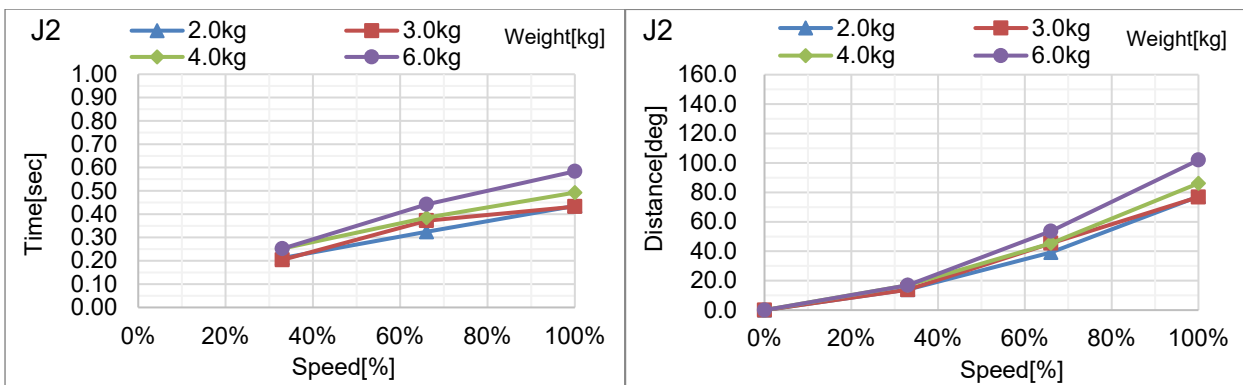

N6-A1000**: J3 (Table Top mounting, Ceiling mounting)

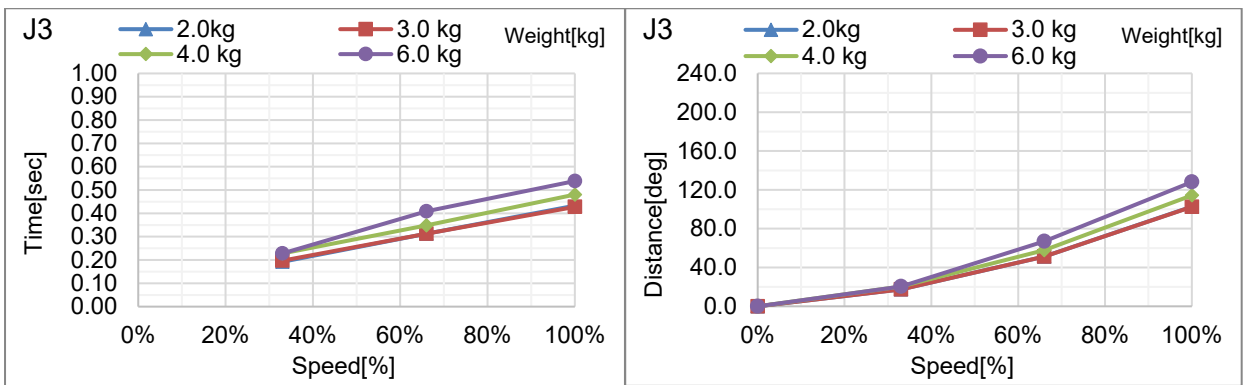

N6-A1000**: J4 (Table Top mounting, Ceiling mounting)

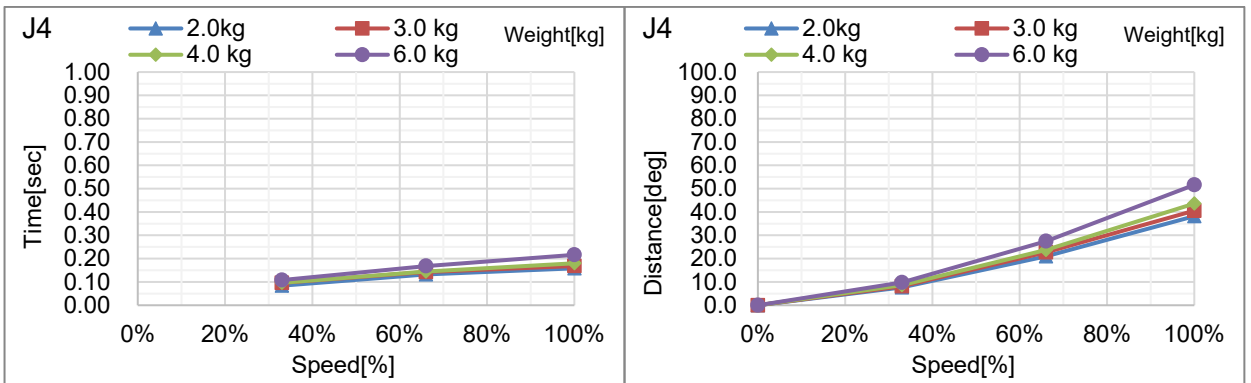

N6-A1000**: J5 (Table Top mounting, Ceiling mounting)

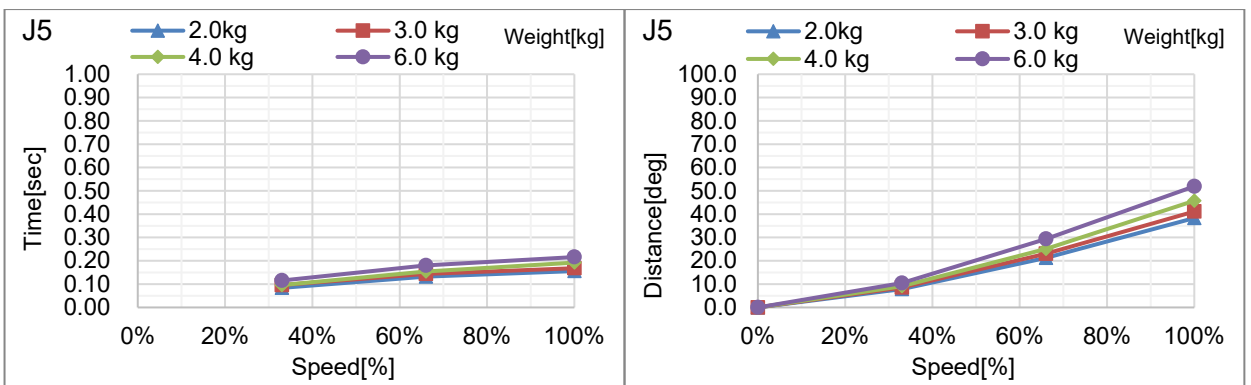

N6-A1000**: J6 (Table Top mounting, Ceiling mounting)

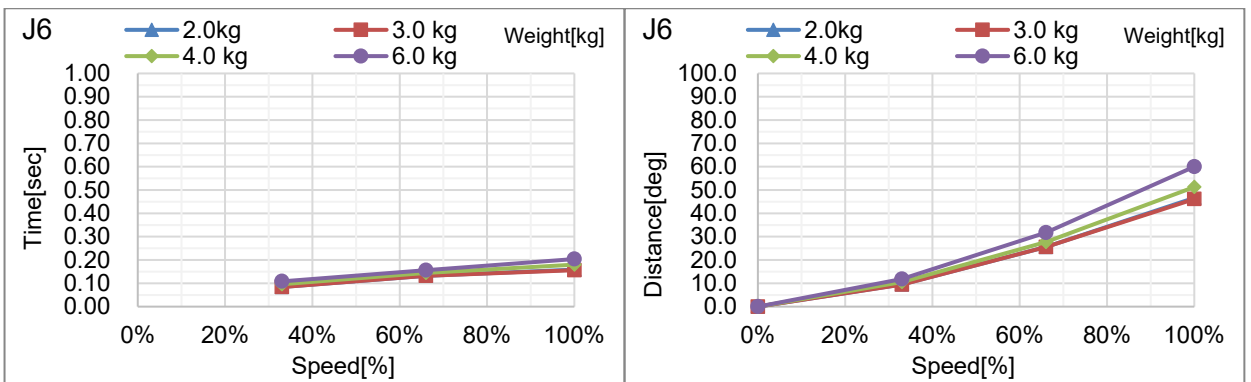

Supplementary Information regarding the Stopping Time and Stopping Distance at Emergency Stop

The stopping time and stopping distance described in Appendix B was measured by the motion determined by us based on the ISO 10218-1.

Therefore, it does not guarantee the maximum value of the stopping time and stopping distance in the customer's environment.

The stopping time and stopping distance differs depending on the robot's model, motion, and input timing of the stop signal. Make sure to always measure the stopping time and stopping distance that matches the customer's environment.

NOTE



The following are included in the robot's motion and parameter.

- The motion's starting point, target point, and relay point
- Motion commands (Go, Move, Jump commands etc.)
- Weight and Inertia Settings
- Motion speed, acceleration, deceleration, and one where the motion timing changes

Also, refer to the following description.

“N2, N6 Manipulator - 4.3 Weight and Inertia Settings“

“N2, N6 Manipulator - 4.4 Precautions for Auto Acceleration “

How to check the stopping time and stopping distance in the customer's environment

Measure the stopping time and stopping distance of the actual motion with the following method.

1. Create a motion program in the customer's environment.
2. After the motion to check the stopping time and stopping distance starts, input the stop signal at your own timing.
3. Record the time and distance from when the stop signal was input until the robot stopped.
4. Check the maximum stopping time and stopping distance by repeating 1 through 3 mentioned above.

- How to input the stop signal: Operate the stop switch manually or input the stop signal with the safety PLC.

- How to measure the stopping position: Measure with a tape measure. The angle could also be measured with the Where or RealPos command.

- How to measure the stopping time: Measure with a stop watch. The Tmr function can also be used to measure the stopping time.



- The stopping time and stopping distance changes depending on the timing the stop signal is input.

In order to prevent collision with people or objects, perform a risk assessment based on the maximum stopping time and stopping distance and perform an equipment design.

Therefore, make sure to measure the maximum value by changing the timing of the stop signal input during the actual motion and measure repeatedly.

Commands that can be useful when measuring stopping time and stopping distance

Commands	Functions
Where	Returns the data of the robot's current position.
RealPos	Returns the current position of the specified robot *Unlike the motion target position of the CurPos, this obtains the position of the actual robot from the encoder in real time.
PAgl	Returns by calculating the Joint position from the specified coordinate value. P1 = RealPos 'Obtain the current position Joint1 = PAgl(P1, 1) ' Request the J1 angle from the current position
Tmr	The Tmr function returns the elapsed time from when the timer starts in seconds.
Xqt	Runs the program specified with the function name and complete the task. The function used to measure the stopping time and stopping distance should be used to run tasks that were launched by attaching the NoEmgAbort options. You can run a task that does not stop with the emergency stop and safeguard open.

For more information, refer to the following manual.

"Epson RC+ SPEL+ Language Reference"

Appendix C: Stopping time and Stopping distance When Safeguard Is Opened

The stopping time and stopping distance when safeguard is opened are shown in a graph for each model.

The stopping time is “Stopping time” in the figure below. Be sure to confirm that safety is ensured according to the installation environment and operation of the robot.

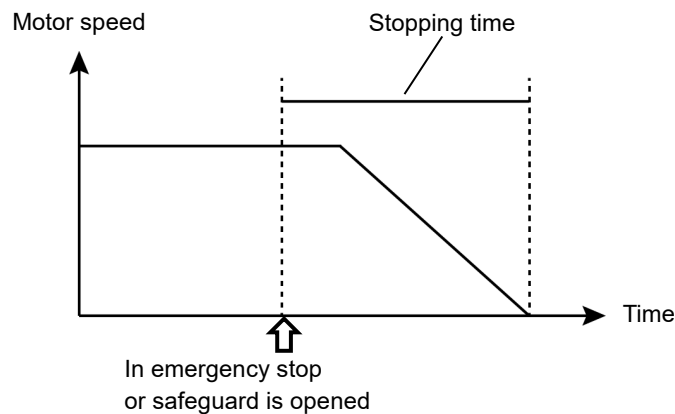

Condition:

The stopping time and stopping distance vary depending on the parameters (setting value) set for the robot. In this chapter, the time and distance are shown with the following parameters.

These conditions are based on the ISO 10218-1:2011 Annex B.

Accel : 100 ,100

Speed: 100 %, 66 %, 33 %Settings

Weight: 100 %, 66 %, 33 % of the maximum payload, rated payload

Arm elongation rate: 100 %, 66 %, 33 % *1

Other : Default

Motion: Singular axis motion of a Go command

Input timing of the Stop signal: input with maximum speed. In this motion, it is the center of the motion range.

*1 Arm elongation rate

The arm elongation rate L is as shown below:

The graphs indicate the results where the stopping time and the stopping distance in the longest among the arm elongation rates.

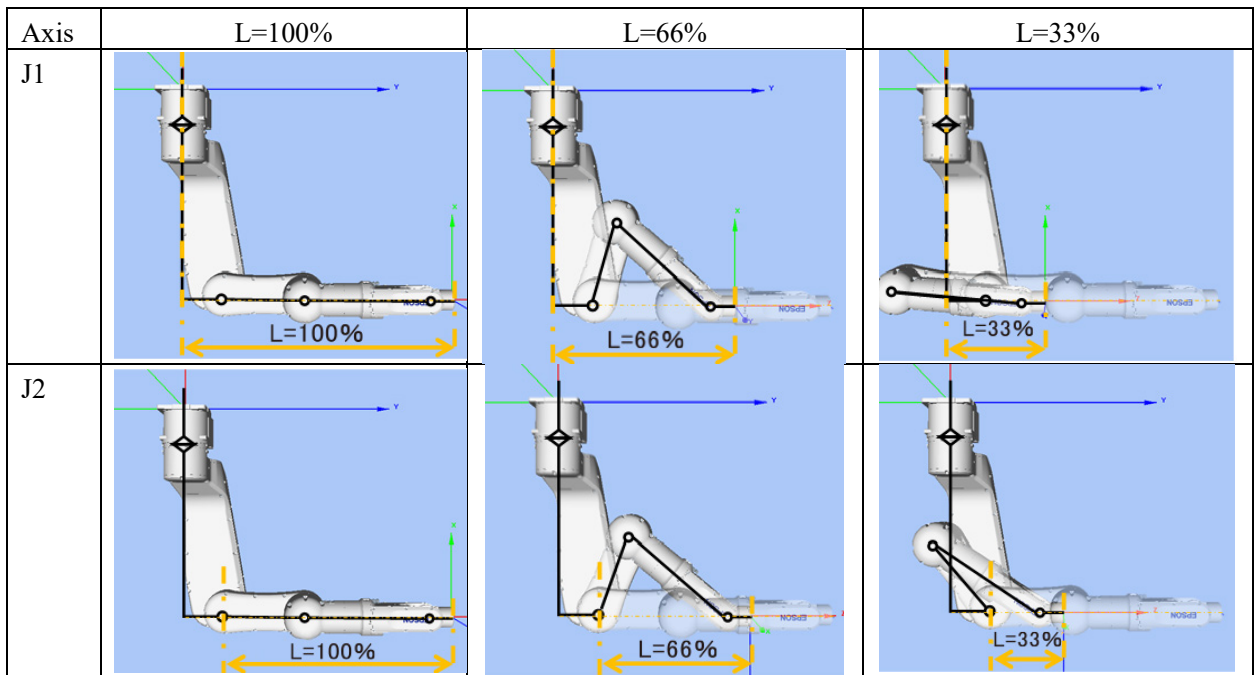

Description of legend:

The graph is shown for each Weight value (at 100%, approx. 66%, and approx. 33% of the maximum payload, and at the rated payload).

- Horizontal axis : Arm speed (Speed value)
- Vertical axis : Stopping time and stopping distance in each arm speed
- Time [sec] : Stopping time
- Distance [deg] : Stopping distance

N2 Stopping time and Stopping distance When Safeguard Is Opened

N2-A450S*: J1 (Table Top mounting, Ceiling mounting)

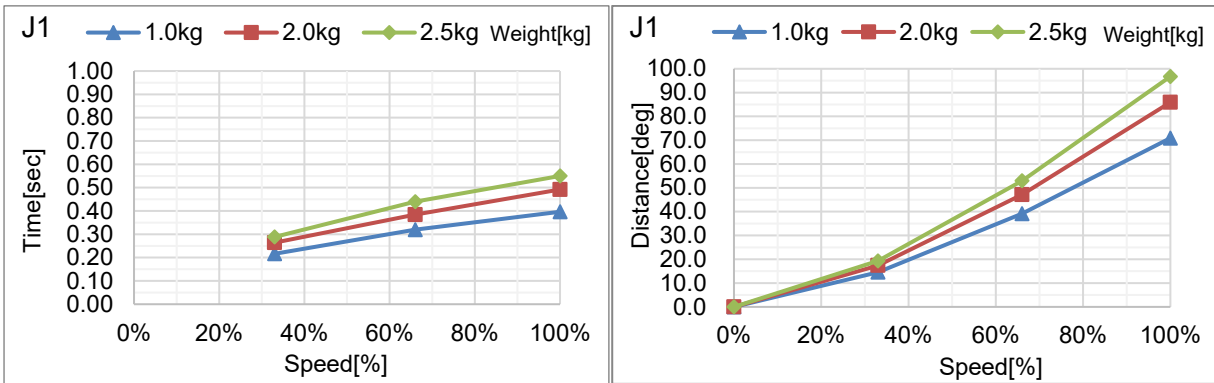

N2-A450S*: J2 (Table Top mounting, Ceiling mounting)

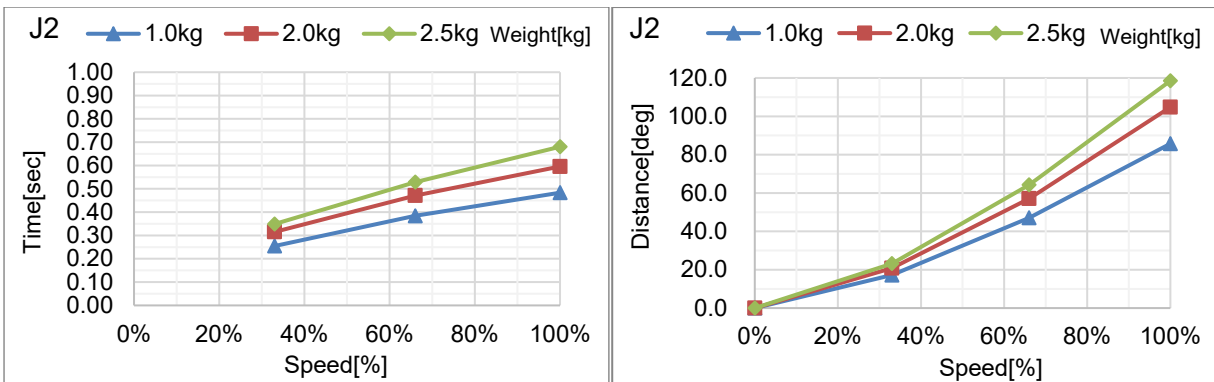

N2-A450S*: J3 (Table Top mounting, Ceiling mounting)

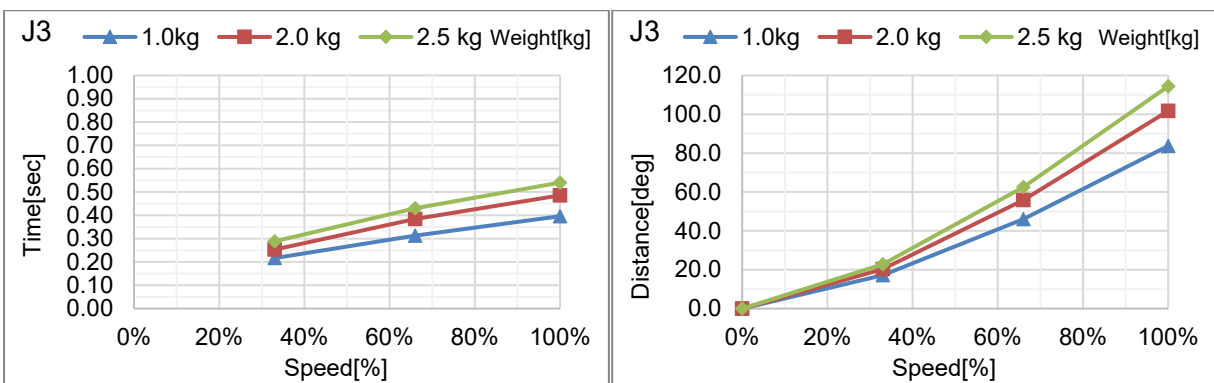

N2-A450S*: J4 (Table Top mounting, Ceiling mounting)

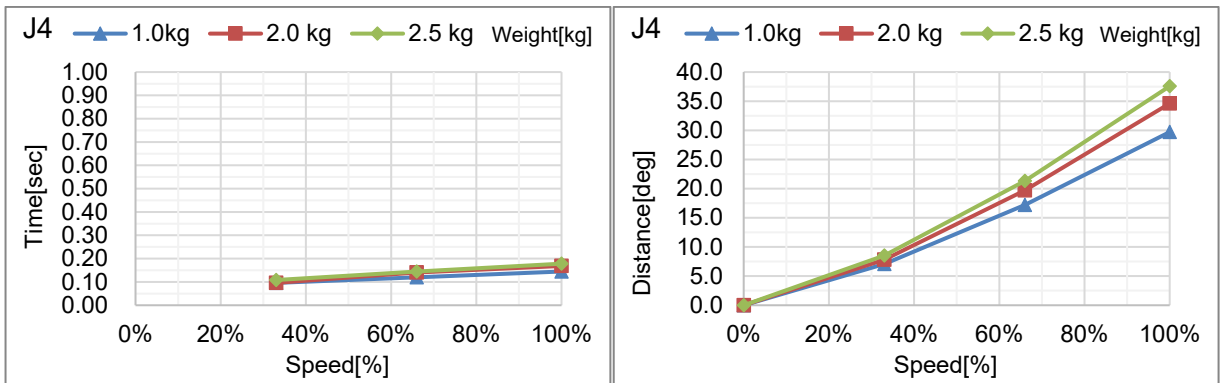

N2-A450S*: J5 (Table Top mounting, Ceiling mounting)

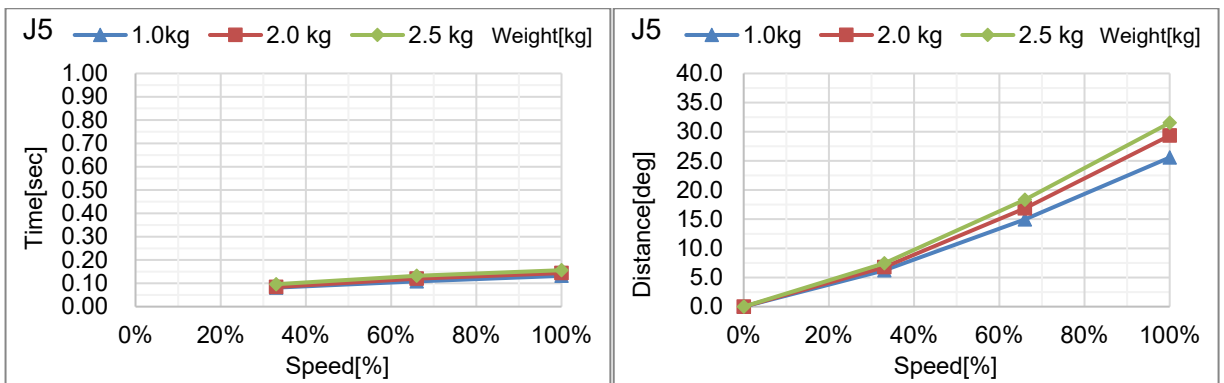

N2-A450S*: J6 (Table Top mounting, Ceiling mounting)

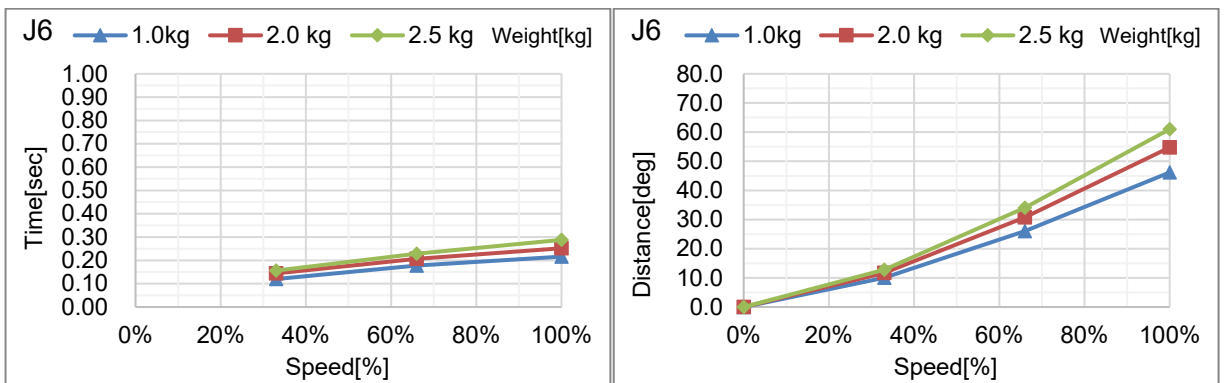

N6 Stopping time and Stopping distance When Safeguard Is Opened

N6-A850**R: J1 (Ceiling mounting)

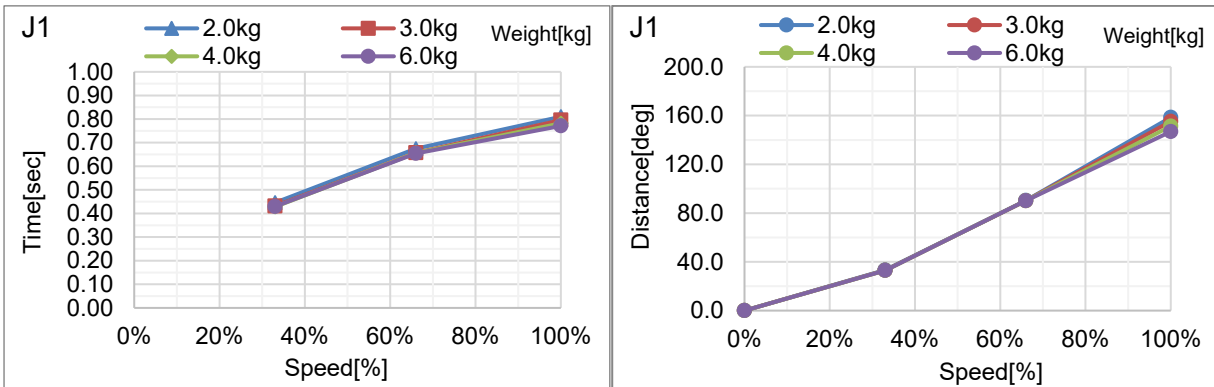

N6-A850**R: J2 (Ceiling mounting)

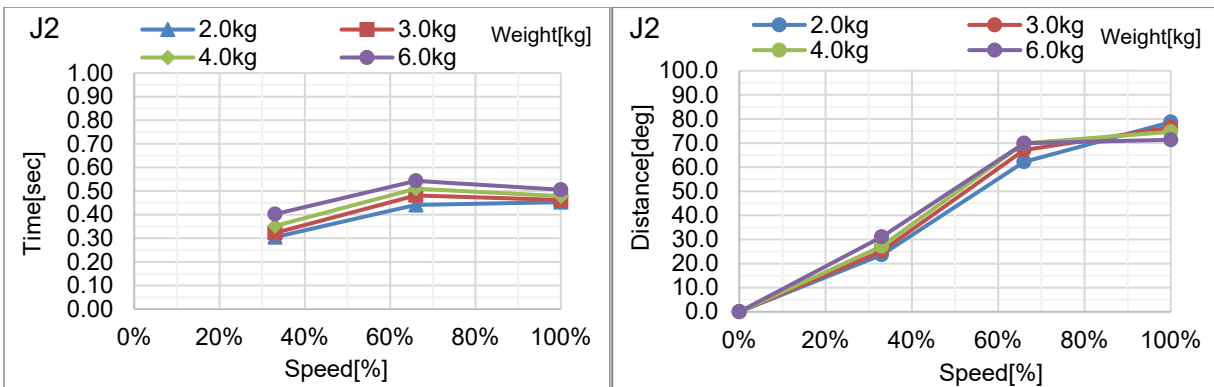

N6-A850**R: J3 (Ceiling mounting)

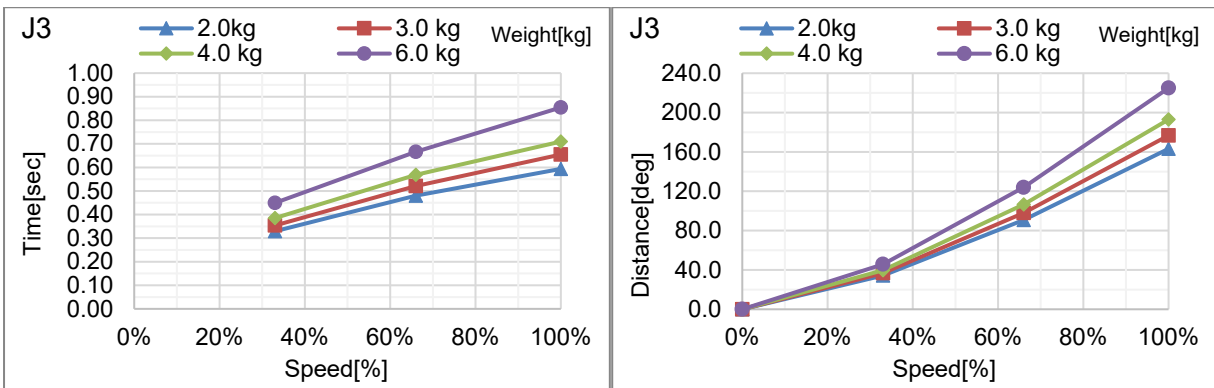

N6-A850**R: J4 (Ceiling mounting)

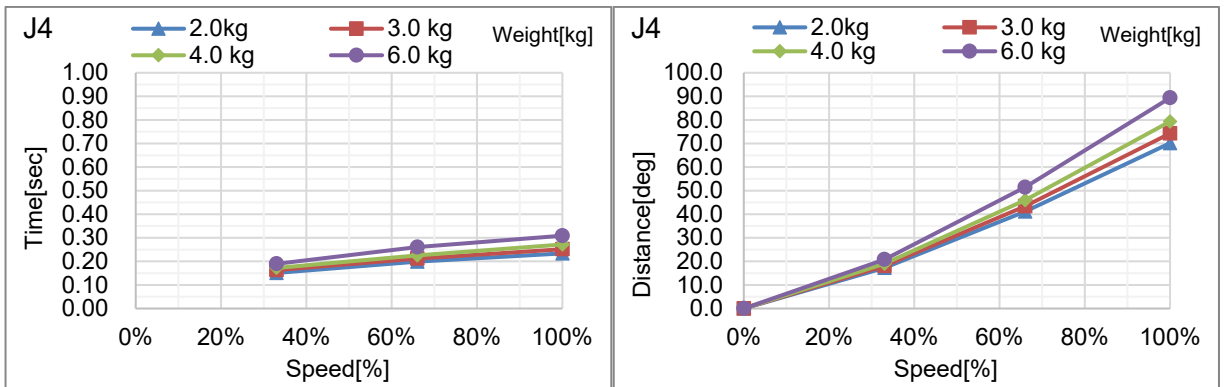

N6-A850**R: J5 (Ceiling mounting)

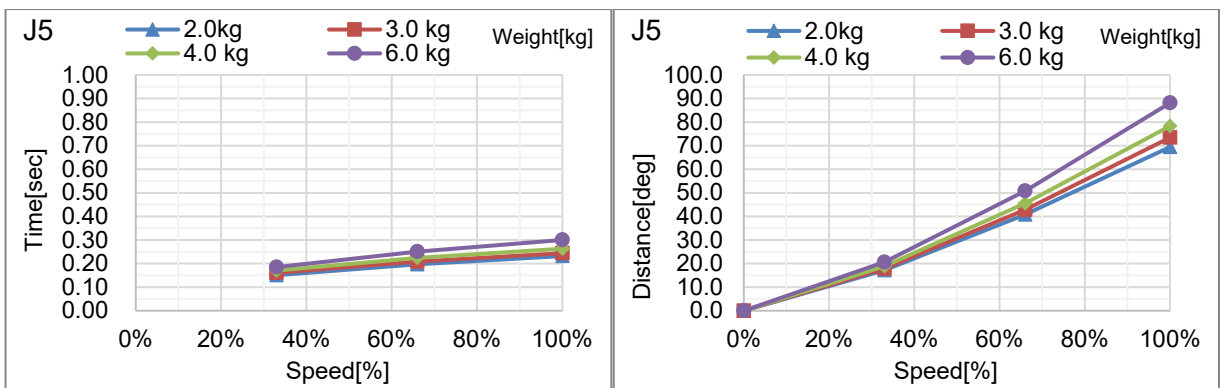

N6-A850**R: J6 (Ceiling mounting)

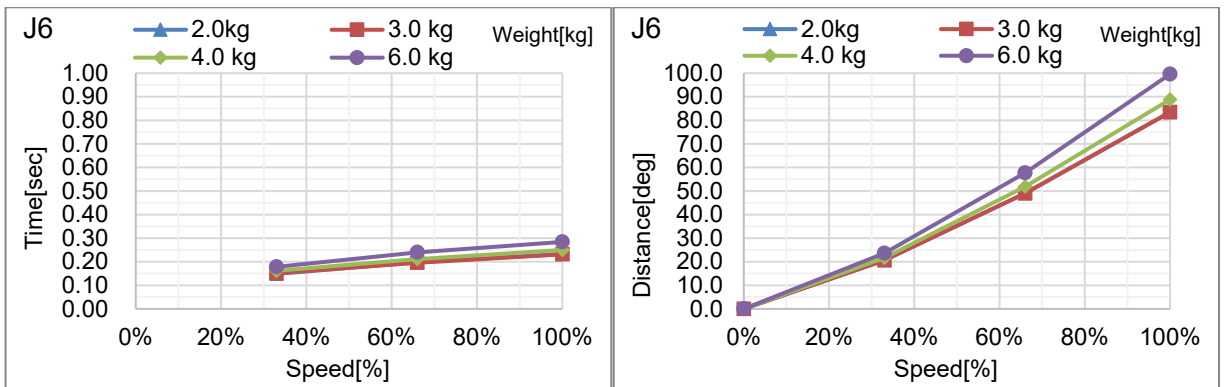

N6-A1000**: J1 (Table Top mounting, Ceiling mounting)

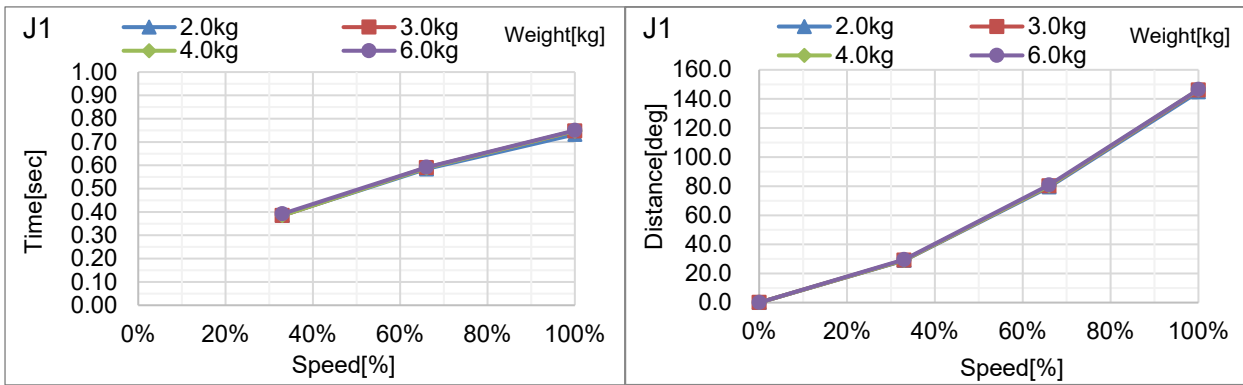

N6-A1000**: J2 (Table Top mounting, Ceiling mounting)

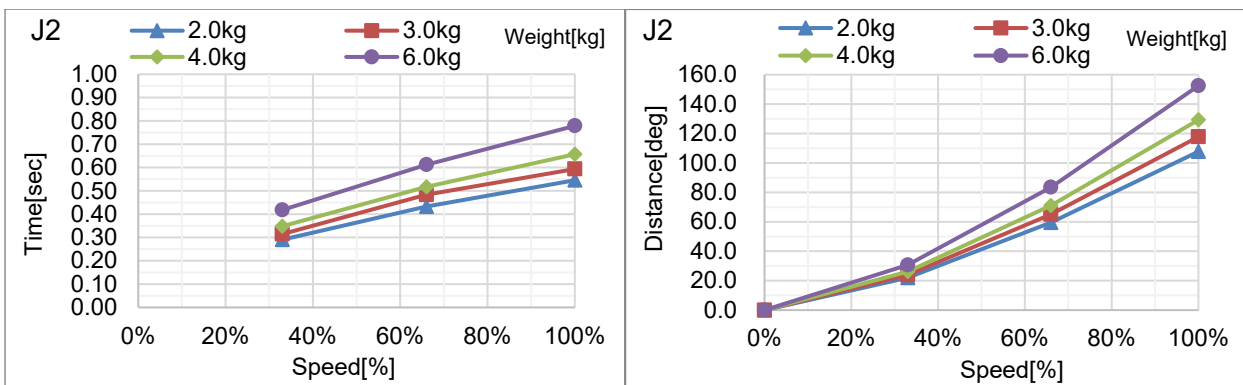

N6-A1000**: J3 (Table Top mounting, Ceiling mounting)

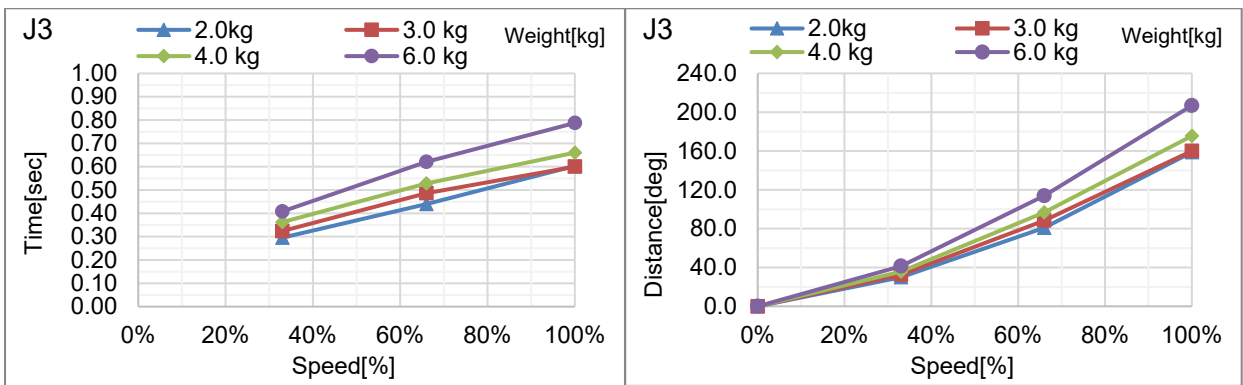

N6-A1000**: J4 (Table Top mounting, Ceiling mounting)

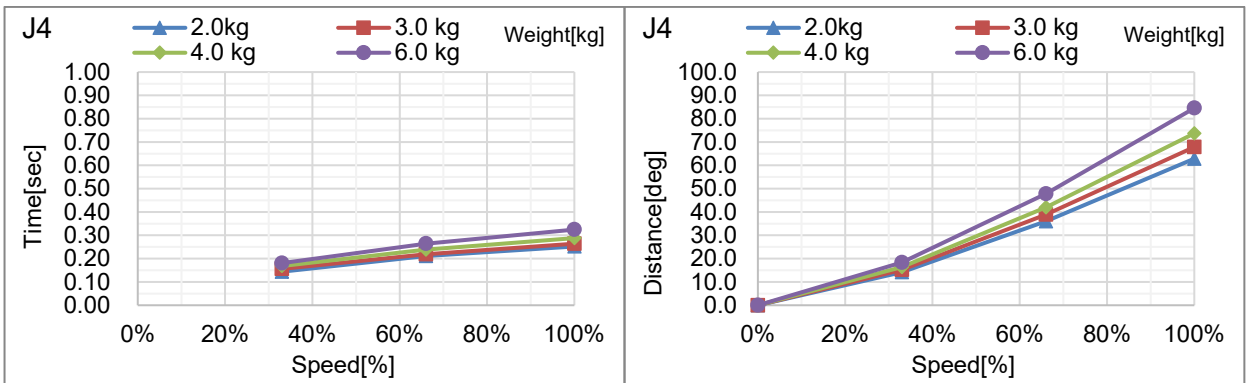

N6-A1000**: J5 (Table Top mounting, Ceiling mounting)

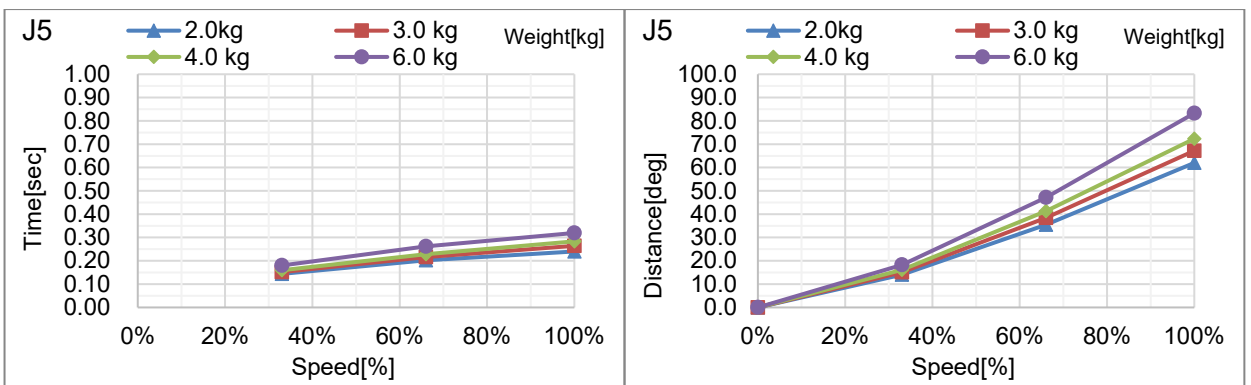

N6-A1000**: J6 (Table Top mounting, Ceiling mounting)

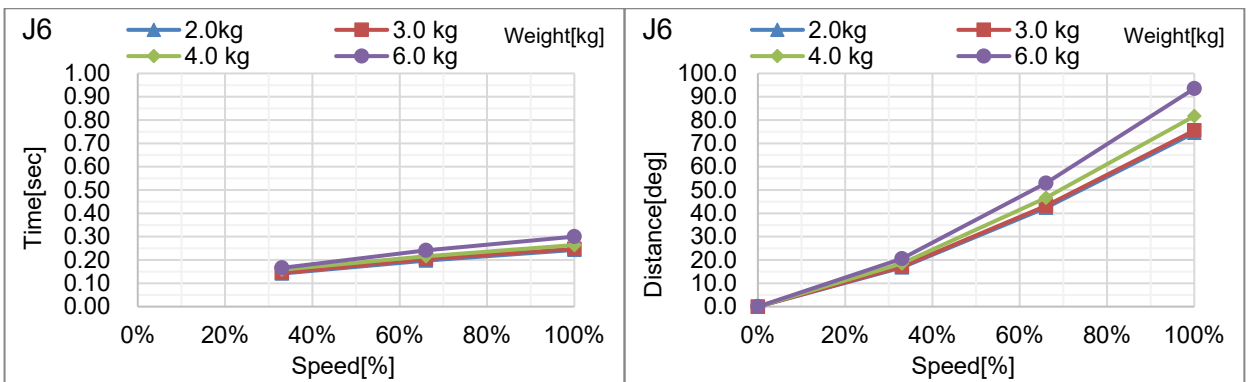

Supplementary Information regarding the Stopping Time and Stopping Distance when the Safeguard is Open

The stopping time and stopping distance described in Appendix C was measured by the motion determined by us based on the ISO 10218-1.

Therefore, it does not guarantee the maximum value of the stopping time and stopping distance in the customer's environment.

The stopping time and stopping distance differs depending on the robot's model, motion, and input timing of the stop signal. Make sure to always measure the stopping time and stopping distance that matches the customer's environment.

NOTE



The following are included in the robot's motion and parameter.

- The motion's starting point, target point, and relay point
- Motion commands (Go, Move, Jump commands etc.)
- Weight and Inertia Settings
- Motion speed, acceleration, deceleration, and one where the motion timing changes

Also, refer to the following description.

“N2, N6 Manipulator - 4.3 Weight and Inertia Settings“

“N2, N6 Manipulator - 4.4 Precautions for Auto Acceleration “

How to check the stopping time and stopping distance in the customer's environment

Measure the stopping time and stopping distance of the actual motion with the following method.

1. Create a motion program in the customer's environment.
2. After the motion to check the stopping time and stopping distance starts, input the stop signal at your own timing.
3. Record the time and distance from when the stop signal was input until the robot stopped.
4. Check the maximum stopping time and stopping distance by repeating 1 through 3 mentioned above.

- How to input the stop signal: Operate the stop switch/safeguard manually or input the stop signal with the safety PLC.

- How to measure the stopping position: Measure with a tape measure. The angle could also be measured with the Where or RealPos command.

- How to measure the stopping time: Measure with a stop watch. The Tmr function can also be used to measure the stopping time.



- The stopping time and stopping distance changes depending on the timing the stop signal is input.

In order to prevent collision with people or objects, perform a risk assessment based on the maximum stopping time and stopping distance and perform an equipment design.

Therefore, make sure to measure the maximum value by changing the timing of the stop signal input during the actual motion and measure repeatedly.

Commands that can be useful when measuring stopping time and stopping distance

Commands	Functions
Where	Returns the data of the robot's current position.
RealPos	Returns the current position of the specified robot *Unlike the motion target position of the CurPos, this obtains the position of the actual robot from the encoder in real time.
PAgl	Returns by calculating the Joint position from the specified coordinate value. P1 = RealPos 'Obtain the current position Joint1 = PAgl(P1, 1) ' Request the J1 angle from the current position
Tmr	The Tmr function returns the elapsed time from when the timer starts in seconds.
Xqt	Runs the program specified with the function name and complete the task. The function used to measure the stopping time and stopping distance should be used to run tasks that were launched by attaching the NoEmgAbort options. You can run a task that does not stop with the emergency stop and safeguard open.

For more information, refer to the following manual.

"Epson RC+ SPEL+ Language Reference"

