



# *epMotion*<sup>®</sup> 5070 with integrated PC and epBlue<sup>™</sup>

Operating manual  
epBlue Version 20



Register  
your instrument!

[www.eppendorf.com/myeppendorf](http://www.eppendorf.com/myeppendorf)

*my*eppendorf

# eppendorf



Copyright © 2012 Eppendorf AG, Hamburg. No part of this publication may be reproduced without the prior permission of the copyright owner.

**Trademarks**

epMotion®, epT.I.P.S.®, eppendorf® and Mastercycler® are registered trademarks of Eppendorf AG, Hamburg, Germany.

Falcon® is a registered trademark of Becton Dickinson, Franklin Lakes, USA.

LightCycler® and MagNA Pure® are registered trademark of Roche Diagnostics.

SIMATIC® is a registered trademark of Siemens AG

Registered trademarks are not marked in all cases with ™ or ® in this manual.

**Table of contents**

<b>1</b>	<b>Operating instructions</b>	<b>7</b>
1.1	Using this manual	7
1.2	Danger symbols and danger levels	7
1.2.1	Hazard icons	7
1.2.2	Degrees of danger	7
1.3	Symbols used	7
1.4	Abbreviations used	8
1.5	Glossary	8
1.6	Change history	9
<b>2</b>	<b>Product description</b>	<b>10</b>
2.1	Main illustration	10
2.2	Delivery package	11
2.3	Features	12
2.3.1	Principle of operation	12
2.4	Overview of hardware and labware	13
2.4.1	Hardware	13
2.4.2	Labware	17
2.4.3	Important volume terms for tubes and wells	19
<b>3</b>	<b>Safety</b>	<b>25</b>
3.1	Intended use	25
3.2	Information on product liability	25
3.3	Warnings for intended use	25
3.4	Warning symbols and safety devices on the device	28
<b>4</b>	<b>Operation</b>	<b>29</b>
4.1	First steps	29
4.1.1	Check correct installation	29
4.1.2	Creating the first user account	29
4.2	Installing or replacing the dispensing tool (tool)	32
4.2.1	Installing the dispensing tool	32
4.2.2	Removing the dispensing tool	33
4.2.3	Notes on the dispensing sequence	33
4.3	Placing labware on the worktable	33
4.3.1	Position labware	34
4.4	Starting and exiting epBlue	34
4.4.1	Start epBlue and log in with your user account	34
4.4.2	Logging out or exiting epBlue	35
4.4.3	General information on working with ID tracking	36
4.5	The Home tab	38
4.5.1	Overview of the Home tab	38
4.5.2	Open recent application	39
4.5.3	Open and manage barcode ID lists	40

4.6	The file window . . . . .	41
4.6.1	Access to the file window . . . . .	41
4.6.2	Opening an application . . . . .	42
4.6.3	Creating a new folder in your user directory . . . . .	43
4.6.4	Creating a new application. . . . .	44
4.6.5	Copying applications and folders from other user directories to one's own . . . . .	46
4.6.6	Editing folder and application properties . . . . .	47
4.6.7	Deleting applications and folders . . . . .	48
4.6.8	Import applications. . . . .	48
4.6.9	Exporting applications . . . . .	50
4.6.10	Open labware for editing . . . . .	51
4.6.11	Deleting a labware combination. . . . .	52
4.7	The Work tab . . . . .	53
4.7.1	Overview of the Work tab. . . . .	53
4.7.2	Worktable tab - equip the worktable . . . . .	58
4.7.3	Procedure tab - defining a procedure . . . . .	63
4.7.4	Reference list of commands and parameters . . . . .	74
4.7.5	The Run tab . . . . .	80
4.7.6	The Control tab . . . . .	87
4.7.7	The Logs tab . . . . .	89
4.8	The Labware tab. . . . .	90
4.8.1	Overview of the Labware tab . . . . .	90
4.8.2	Activate or deactivate labware . . . . .	93
4.8.3	Adjusting the labware bottom tolerance . . . . .	93
4.8.4	Filling racks and module racks with tubes . . . . .	95
4.8.5	Fill reservoir rack with reservoirs and filled module racks . . . . .	98
4.9	The Functions tab. . . . .	101
4.9.1	Overview of the Functions tab . . . . .	101
4.9.2	Barcode reader . . . . .	102
4.9.3	Optical sensor . . . . .	102
4.9.4	Tool interlock . . . . .	103
4.9.5	Firmware Update . . . . .	104
4.9.6	Dosing device . . . . .	104
4.10	The Admin tab . . . . .	105
4.10.1	Logging in as administrator . . . . .	105
4.10.2	Overview of the Admin tab. . . . .	105
4.10.3	Account Overview . . . . .	108
4.10.4	Edit accounts . . . . .	109
4.10.5	Set up a new password . . . . .	113
4.10.6	Group overview . . . . .	114
<b>5</b>	<b>Quick start . . . . .</b>	<b>115</b>
5.1	Short instructions . . . . .	115
5.1.1	Select and start the epMotion method . . . . .	115
5.2	Example method for epMotion . . . . .	116
5.2.1	Method objective . . . . .	116
5.2.2	Sample preparation . . . . .	116
5.2.3	Creating the example method . . . . .	116
5.2.4	Starting the method . . . . .	125

<b>6</b>	<b>Troubleshooting</b>	<b>127</b>
6.1	Error search	127
6.2	General errors	127
6.2.1	Read error of the optical sensor	127
6.2.2	Dispensing error	128
6.3	Error messages	128
<b>7</b>	<b>Maintenance</b>	<b>155</b>
7.1	Service	155
7.1.1	Replacing the sealing rings of the eight-channel dispensing tool	155
7.1.2	Maintaining the dispensing tools	155
7.2	Cleaning	156
7.2.1	Cleaning the worktable	156
7.2.2	Cleaning the work surface adapter	156
7.2.3	Cleaning the dispensing tools	156
7.2.4	Cleaning the barcode reader	156
7.2.5	Cleaning the thermoadapter, thermoblock and thermorack	156
7.2.6	Autoclaving Labware	157
7.3	Decontamination before shipment	157
<b>8</b>	<b>Technical data</b>	<b>158</b>
8.1	Power supply	158
8.2	Ambient conditions	158
8.3	Weight/dimensions	158
8.4	Interfaces	158
8.5	Dispensing Tools	159
8.6	Additional specifications	160
8.6.1	Barcode reader	160
8.6.2	Noise level	160
8.6.3	Optical sensor	160
8.6.4	Carrier	160
<b>9</b>	<b>Ordering information</b>	<b>161</b>
9.1	Accessories	161
9.1.1	Automated pipetting system epMotion 5070	161
9.1.2	Dispensing tools	161
9.1.3	epT.I.P.S. Motion pipette tips	161
9.1.4	Reservoirs	162
9.1.5	Racks for individual tubes	163
9.1.6	ReservoirRack modules	163
9.1.7	Height adapter	163
9.1.8	Additional Accessories	164
9.1.9	Accessories for real-time PCR	164
<b>10</b>	<b>Transport, storage and disposal</b>	<b>166</b>
10.1	Shut down	166
10.2	Installation after transport	166
10.3	Disposal	167

<b>11</b>	<b>Appendix A: Hardware</b>	<b>168</b>
11.1	Labware	168
11.1.1	Introduction	168
11.1.2	Overview of labware	169
11.1.3	Abbreviations used	181
11.1.4	Labware definitions	183
11.1.5	Compile your own labware combinations.	183
11.2	Tools (dispensing tools)	184
11.3	Optical sensor	186
11.3.1	Function	186
11.3.2	Detection version 1: detecting liquid surfaces	188
11.3.3	Detection variant 2: Tip detection	190
11.3.4	Detection variant 3: Location detection	190
11.3.5	Detection limits	191
<b>12</b>	<b>Appendix B: Software</b>	<b>192</b>
12.1	Commands, parameters, options	192
12.1.1	Number of Samples	192
12.1.2	Sample Transfer	194
12.1.3	Reagent Transfer	206
12.1.4	Dilute	207
12.1.5	Pool	210
12.1.6	Pool One destination	211
12.1.7	Mix	213
12.1.8	Exchange	215
12.1.9	Wait	215
12.1.10	Comment	216
12.1.11	User Intervention	216
12.2	Importing commands from a CSV file	217
12.2.1	Creating a CSV file for import	217
12.2.2	Importing a CSV file	219
12.3	Importing and exporting labware combinations	221
12.3.1	Importing labware combinations	221
12.3.2	Export labware combinations	222
12.4	Defined applications	223
<b>13</b>	<b>Appendix C: BIOS password</b>	<b>224</b>
13.1	Changing the BIOS password	224
	<b>Index</b>	<b>225</b>

## 1 Operating instructions

### 1.1 Using this manual



#### Material damage due to incorrect use.

- ▶ Only use the product for its intended purpose as described in the operating manual.
- ▶ Ensure adequate material resistance when using chemical substances.
- ▶ In case of doubt, contact the product manufacturer.

- ▶ Before using the epMotion 5070 for the first time, please read the operating manual.
- ▶ Please view this manual as part of the product and keep it somewhere easily accessible.
- ▶ When passing on the device, always enclose the operating manual.
- ▶ If this manual is lost, please request another one. The current version of the operating manual can be found on our website at [www.eppendorf.com](http://www.eppendorf.com).

### 1.2 Danger symbols and danger levels

#### 1.2.1 Hazard icons

	<b>Biohazard</b>		<b>Explosion</b>
	<b>Electric shock</b>		<b>Hot surface</b>
	<b>Hazard point</b>		<b>Material damage</b>

#### 1.2.2 Degrees of danger

The degree of danger is a part of a safety note and distinguishes the possible results of non-observance from each other.

<b>DANGER</b>	<i>Will</i> lead to severe injuries or death.
<b>WARNING</b>	<i>May</i> lead to severe injuries or death.
<b>CAUTION</b>	May lead to light to moderate injuries.
<b>NOTICE</b>	May lead to material damage.

### 1.3 Symbols used

Symbol	Meaning
▶	Handling
1. 2.	Actions in the specified order
•	List
<i>Text</i>	Name of fields in the software
	Useful information

## 1.4 Abbreviations used

<b>DWP</b>	Deepwell plate
<b>epT.I.P.S.</b>	eppendorf Totally Integrated Pipetting System
<b>MMC™</b>	MultiMediaCard™
<b>MTP</b>	Micro test plate
<b>PCR</b>	Polymerase Chain Reaction

## 1.5 Glossary

### A

**Application** Programs for a specific application. An application includes the procedure and the equipping of the worktable.

### B

**Barcode ID** Character string that epBlue uses to identify samples and labware.

**Barcode reader** Device for reading a barcode.

### C

**Command** A step in a procedure. Various parameters can be set for commands. Each command triggers an action, e.g., the transport of liquids.

### D

**Destination labware** Labware that liquid is dispensed into during the application. Destination labware refers to a plate or rack.

**Destination location** Position that liquid is dispensed into during the application.

**Destination vessel** Vessel liquid is dispensed into during the application.

**Dispensing tool** Tool that aspirates and dispenses liquid. Single-channel dispensing tools and eight-channel dispensing tools are available for various volume ranges.

### E

**Entry list** List with information on the barcode ID. For example, the list contains the position and name of a sample. If you would like to import an entry into epBlue, you do not need to manually enter the barcode IDs. epBlue imports entry lists as CSV or XML files.

**epT.I.P.S.® Motion** epMotion pipette tips. Only epT.I.P.S.® Motion can be used on the epMotion. epT.I.P.S.® Motions are available with or without a filter.

### F

**Filling volume** Maximum liquid volume of a labware. The epMotion uses the gripper to transport the labware up to the filling volume. The epMotion aspirates liquid from the labware up to the filling volume. The filling volume is higher than the working volume.

### H

**Height adapter** Adapter for low labware. The height differences among the labware will be offset to decrease the tool holder paths, thereby decreasing the run time of the application as well.

### I

**Input list** List with information on an ID-marked source labware. In the list, IDs and positions of the samples, which are located in the source labware, are stored in addition to other information. An input list is created for each ID-marked source labware when the application is started, see *Result list*.

**Intermediate labware** Labware that is used to dispense and aspirate liquids during the application.

**Intermediate labware** Vessel that is used to dispense and aspirate liquids during the application.

**Intermediate location** Position that is used to dispense and aspirate liquids during the application.

### L

**Labware** Racks, plates, tips, etc. which are placed on the worktable.

**Location** Area where labware is placed on the worktable.

**P**

**Pattern** Pattern in which liquid is aspirated and dispensed. Patterns are defined in a transfer command. Patterns are defined as regular patterns, standard patterns and irregular patterns. Patterns are independent in x-direction and y-direction.

**PCR clean** PCR clean is an Eppendorf AG purity grade for consumables. PCR clean meets the requirements for standard products, e.g., precision, accuracy, wetting behavior, tightness. PCR clean also meets the requirements with regard to absence of human DNA, DNase, RNase and PCR inhibitors.

Consumables with the PCR clean purity grade are controlled and certified by an external laboratory.

Certificates are available for downloading from our webpage [www.eppendorf.com](http://www.eppendorf.com).

**Procedure** Sequence of commands that are executed one after the other. Part of an application.

**R**

**Rack** Mount for tubes or pipette tips.

**Reservoir** Reservoirs are used to hold reagents. Reservoirs are hung in a ReservoirRack or placed directly on the worktable.

**Result list** List with information on an ID-marked destination labware. In the list, IDs and positions of the samples, which are located in the destination labware, are stored in addition to other information. A result list is created for each ID-marked destination labware at the end of an application, see *Input list*.

**S**

**Source labware** Labware that liquid is aspirated from during the application. Source labware refers to a plate or rack.

**Source vessel** Vessel liquid is aspirated from during the application.

**T**

**Thermorack** Temperable rack for smaller vessels, e.g., Safe-Lock tubes for 0.5 mL, 1.5 mL or 2 mL.

**Tube** Tube or single well of a plate.

**W**

**Working volume** Liquid volume for a labware. The epMotion fills a vessel with low levels of contamination up to the working volume. The working volume is less than the filling volume.

**Worktable** epMotion work surface where labware and tools are placed. In the software, the epMotion worktable is shown as the epBlue worktable.

**1.6 Change history**

Operating manual version	Date	Corresponding software version	Changes
5070 900.469-01	January 2011	epBlue 20	Adjustments for epBlue GxP
5075 900.469-02	October 2012	epBlue 20.4.1 and higher	Description of the ID functions updated. Preset administrator password changed Error corrections.

**2 Product description**

**2.1 Main illustration**

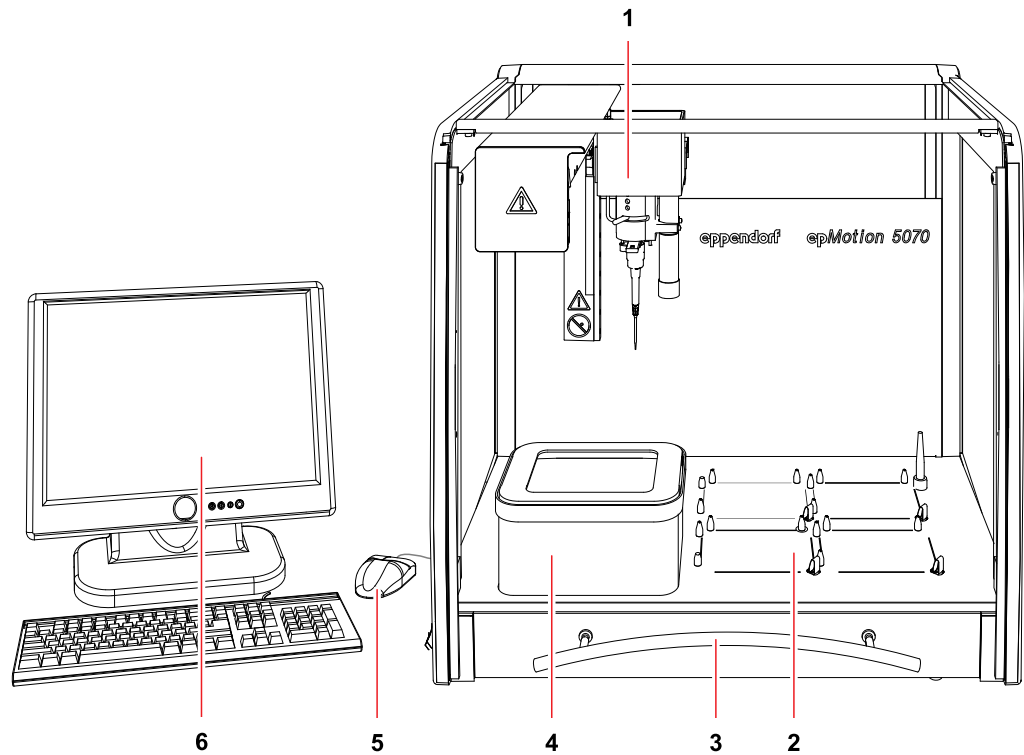

Fig. 1: Front view of the epMotion 5070

<b>1 Carrier</b>	<b>2 Worktable</b>
<b>3 Front hood</b>	<b>4 Waste container</b>
<b>5 Mouse</b>	<b>6 Monitor</b>

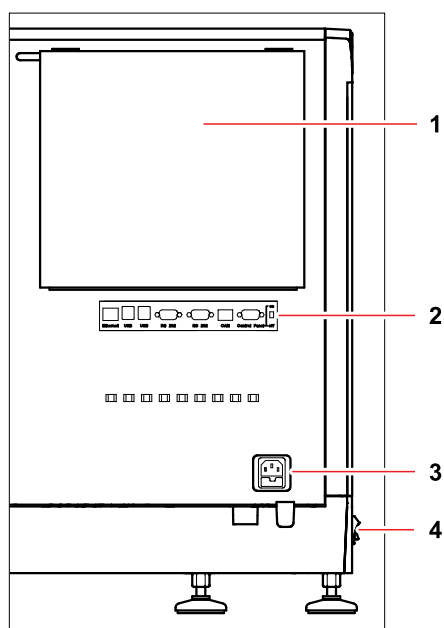

Fig. 2: Section of the rear view of the epMotion 5070

<b>1 PC</b>	<b>2 Interfaces (see p. 166)</b>
<b>3 Mains power supply</b>	<b>4 Mains switch</b>

Only connect devices to the interfaces that meet the IEC 950/EN 60950 (UL 1950) standards.

## 2.2 Delivery package

Quantity	Order no. (international)	Order No. (North America)	Description
1	5070 000.140	960000100	<b>Automated pipetting system epMotion 5070 with integrated PC</b> as 5070 700.000 plus integrated industrial PC, keyboard and mouse
1	–	–	<b>epBlue software installation CD-Rom</b> With an operating manual as a PDF
1	–	–	<b>Recovery DVD for Simatic 627 industrial PC</b>
1	5075 753.006	960002016	<b>Waste box</b>
1	–	–	<b>Optical sensor</b>
1	–	–	<b>Power cable</b> Compatible to the country where the order was placed or determined
1	–	–	<b>epMotion 5070 Operating Manual</b>
1	–	–	<b>Tool for transport safety device</b>

The accessories for **epMotion** with epBlue from **version 20** are expanded by the following:

Quantity	Order no. (international)	Order No. (North America)	Description
1	– (only epBlue ID)	–	<b>Barcode reader</b> With USB connection cable and table stand
1	–	–	<b>USB dongle ("eLicensor")</b> With epBlue hardware key code card



A detailed overview of the accessories and the article numbers can be found separately (see *Accessories* on p. 161).

## 2.3 Features

With epMotion 5070 you execute dispensing processes automatically. The PC with epBlue software is used to control the epMotion 5070.

epMotion 5070 can be supplied with a variety of dispensing tools which are inserted manually. These dispensing tools and the appropriate pipette tips in each case (epT.I.P.S. Motion) can be used to dispense quantities of liquid in the volume range from 1 µL to 1000 µL.



Also refer to the operating manual of the industrial PC and the keyboard.



Barcode

The epBlue ID variant allows the tracking of samples using barcodes and the connection to lab information systems.

### 2.3.1 Principle of operation

The liquid is samples from the source tube in pipette tips, transported and deposited in the destination tube.

On request, an optical sensor automatically checks the correct selection and positioning of tubes, available supplies and the position of pipette tips in the rack, as well as liquid level in some tubes.

With the aid of predefined commands, you can create and edit simple or complex dispensing operations yourself and combine these into methods. In the process, you specify in the software, among other things, the source location and destination location as well as the desired dispensing or transport pattern.

For further information, go to [www.epMotion.com](http://www.epMotion.com)

## 2.4 Overview of hardware and labware

Familiarize yourself with the epMotion 5070 and the labware prior to first use.

### 2.4.1 Hardware

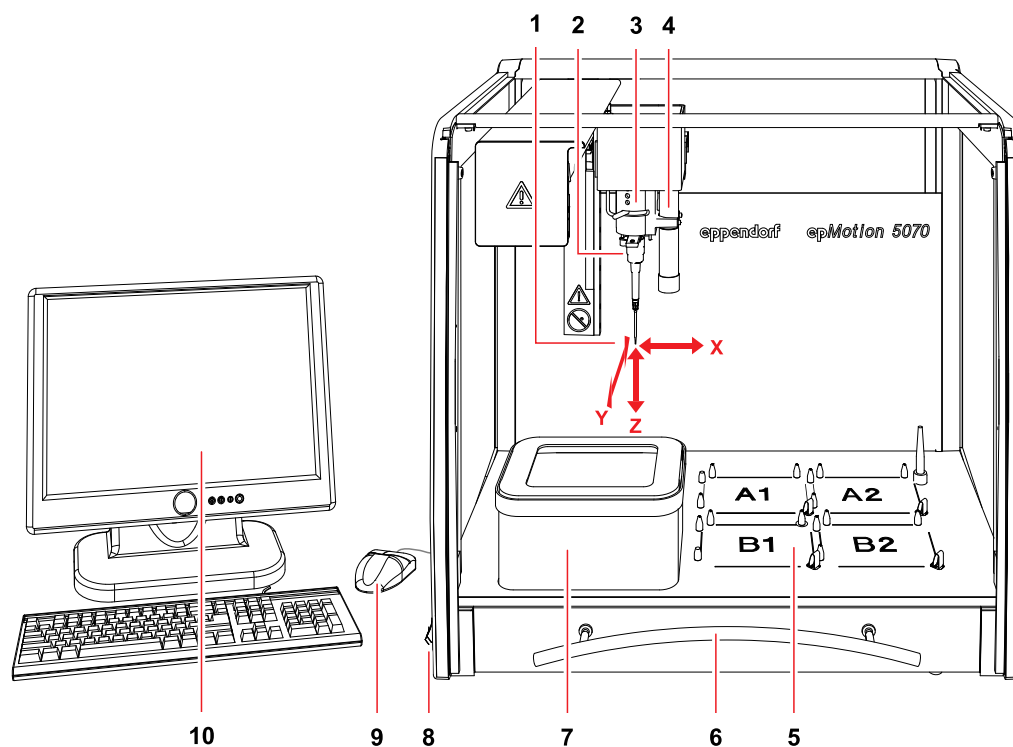

<b>1</b> Directions of movement of the carrier	<b>2</b> Dispensing tool
<b>3</b> Carrier	<b>4</b> Optical sensor
<b>5</b> Locations Locations A1, A2, B1 and B2 for labware.	<b>6</b> Front hood Can be pushed up to open the inner space.
<b>7</b> Waste container (standard) The waste container can be autoclaved; can be washed in a dishwasher.	<b>8</b> Mains/power switch For switching on and off.
<b>9</b> Mouse	<b>10</b> PC monitor

#### Work surface adapter for the epMotion worktable

The work surface adapter for the epMotion worktable consists of a set of 4 screw-on feet for adjusting the height of the epMotion. The screw-on feet may only be installed by service personnel authorized by Eppendorf.

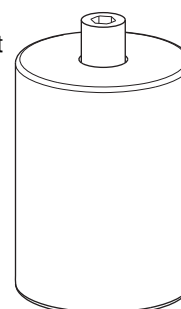

**Dispensing tools (tools)**

A total of six different dispensing tools is available for selection. For the three volume ranges 1 to 50 µL, 20 to 300 µL and 40 to 1000 µL a single-channel dispensing tool (TS xx) and an eight-channel dispensing tool (TM xx-8) are available in each case.

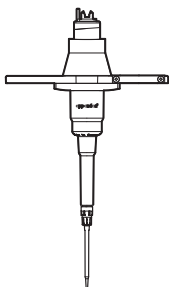

Fig. 3: Single-channel dispensing tool

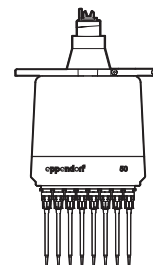

Fig. 4: Eight-channel dispensing tool

Dispensing tool	Volume range
TS 50	1 µL – 50 µL
TM 50-8	
TS 300	20 µL – 300 µL
TM 300-8	
TS 1000	40 µL – 1000 µL
TM 1000-8	

**Barcode reader**



Barcode

Only for a epMotion with epBlue ID and barcode reader.

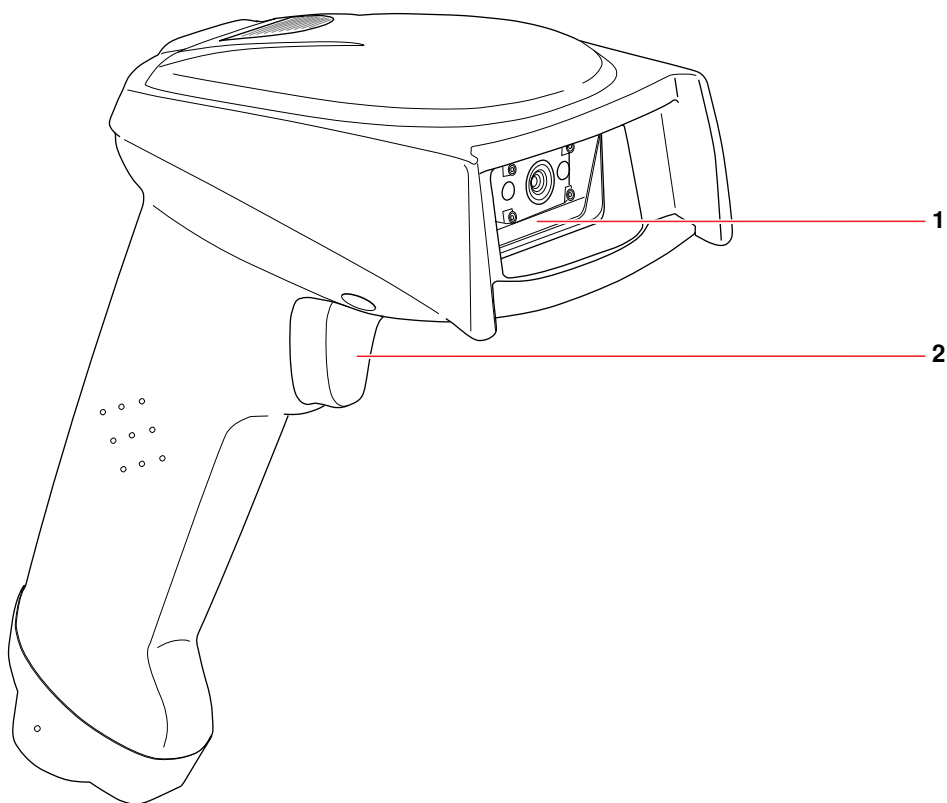

<b>1 The</b>	<b>2 Press the</b>
--------------	--------------------

The barcode reader is connected to a USB port of the industrial PC. To be able to use the barcode functions in the software, the supplied dongle (hardware key, "eLicenser") must be enabled (see separate enclosed leaflet) and connected to the industrial PC. The barcode reader has 2 operating modes:

- Manual trigger mode: press the key on the barcode reader to read data.
- Demand mode: the barcode reader continuously reads data and only needs to be held in the vicinity of a barcode for it to be able to detect and read it.

You can change the mode in the *Admin* tab of the epBlue software (see *The Admin tab on p. 105*).

The system allows you to track samples and document the used samples and reagents using barcode IDs. The barcode IDs can be read or entered at the start of a run. After completion of the run, the system issues a result list with the barcode IDs of the samples and their location in the labware.

## Optical sensor

The optical sensor is located in a tube to the right of the carrier.

With the aid of an optical procedure the optical sensor measures the light reflection of surfaces, e.g., of labware on the worktable or of liquids placed in the tubes.

The optical sensor performs the following checking tasks on the epMotion 5070:

- Detecting codes on tip racks and tube racks
- Determining existing stocks of tips in positioned tip racks so that tip racks which have been started can also continue to be used
- Checking whether the correct rack has been inserted (height detection)
- Detecting height of plates
- Detecting whether a location programmed as occupied on the worktable really is occupied
- Detecting 30 mL or 100 mL reservoirs (reaction vessels) and ReservoirRack modules in the ReservoirRack.
- automatically checking the adjustment of the entire device by means of exact measuring points on the surface of the worktable
- detecting the filling level of the liquids (liquid detection) in reservoirs, tubes and plates

Liquid Detection and Location detection can be performed for a labware height up to 107 mm.

---

### CAUTION!

#### Faulty liquid detection due to air bubbles.

Liquid detection cannot be performed reliably if there are air bubbles in tubes or wells.

- ▶ Before the start of a method, ensure that there are no air bubbles in tubes or wells.
- ▶ Remove bubbles by tapping the tubes or plates sharply several times.

---

To save time and depending on the requirements of the current method, you can use the software to activate or deactivate the individual functions of the optical sensor.



## Waste system

The standard waste container can hold approx. 400 individually-ejected 1000 µL tips or correspondingly more of smaller tip sizes.

## 2.4.2 Labware

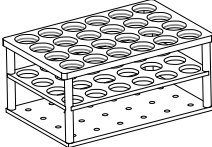
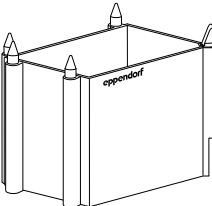
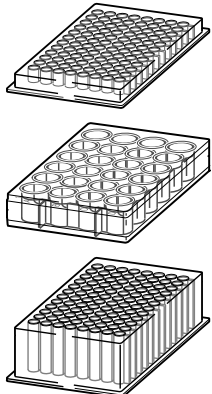
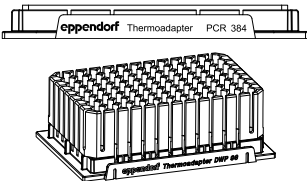
The following list gives you an overview of the labware of the epMotion 5070. More information on available labware components can be found in the appendix (see *Labware on p. 168*) as well as in the Internet at [www.epMotion.com](http://www.epMotion.com).

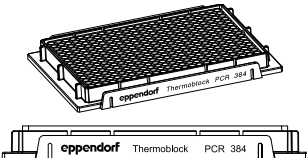
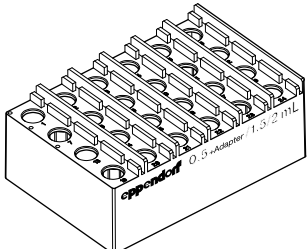
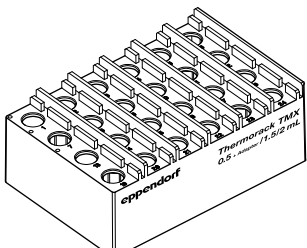
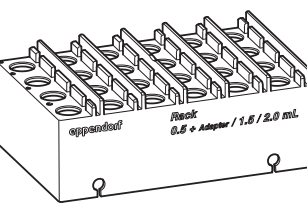
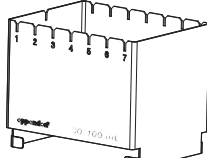
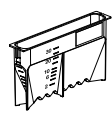
Labware	Description	Labware folder/ more information
<b>Tubes</b>	<p>You can use different reactions vessels on the epMotion 5070 by loading ReservoirRack modules, racks and thermoracks:</p> <ul style="list-style-type: none"> <li>• Safe-Lock tubes</li> <li>• Standard tubes 3810X</li> <li>• PCR tubes</li> <li>• Conical tubes</li> <li>• Tubes from various manufacturers</li> </ul>	<p><i>Equip Racks + Modules with Tubes</i></p>
<b>Racks</b> 	<p>Racks are tube holders for up to 24 tubes with various diameters.</p>	<p><i>Equip Racks + Modules with Tubes</i> <i>(see Racks for reagent tubes on p. 170)</i></p>
<b>Height adapter</b> 	<p>To keep carrier travel times and distances as short as possible, there are various height adapters (with a height of 40, 55 and 85 mm) which you can use to compensate for different heights of plates.</p>	<p><i>Adapter</i> <i>(see Height adapter on p. 179)</i></p>
<b>Plates</b> 	<p>You can use different plates on the epMotion 5070:</p> <ul style="list-style-type: none"> <li>• Microplates (MTP) with 6, 24, 48, 96 or 384 wells</li> <li>• Deepwell plate (DWP) with 24, 96 or 384 wells</li> <li>• PCR plates with frame (skirted) with 96 or 384 wells</li> <li>• Filter plates</li> <li>• Tube plates with 96 individual tubes</li> <li>• Rack for microtubes in a 96-well grid</li> </ul>	<p><i>Plates</i> <i>(see Plates on p. 180)</i></p>
<b>Thermoadapter</b> 	<p>The PCR thermoadapter is used for temperature controlling 96-well and 384-well PCR plates. However, it does not form a fixed combination with a plate.</p> <p>The thermoadapter DWP/96 is used for temperature controlling 96-well DWP plates. However, it does not form a fixed combination with a plate.</p>	<p><i>Adapter</i> <i>(see Thermoadapter on p. 174)</i></p>

Labware	Description	Labware folder/ more information
<p><b>Thermoblock</b></p> 	<p>The thermoblock is used for temperature controlling 96-well PCR plates (e.g., Eppendorf twin.tec semi-skirted or skirted). It forms a fixed combination with the plate which can only be moved together.</p>	<p><i>Thermoblocks with plates</i> (see <i>Thermoblock (384 wells)</i> on p. 173)</p>
<p><b>Thermoracks</b></p> 	<p>The thermorack with lid holder and 24 positions which can be temperature controlled is for the temperature control of smaller tubes (e.g., Eppendorf Safe-Lock tubes for 0.5 mL, 1.5 mL or 2 mL). The thermorack has a high heat capacity and a slower heat transfer i.e. it retains the temperature away from the temperature control over a longer time period. But it also takes longer to reach the desired temperature.</p>	<p><i>Equip Racks + Modules with Tubes</i> (see <i>Thermoracks and thermoracks TMX</i> on p. 172)</p>
<p><b>Thermoracks TMX</b></p> 	<p>The thermorack TMX with lid holder and 24 positions which can be temperature controlled is for the temperature-control of smaller tubes (e.g., Eppendorf Safe-Lock tubes for 0.5 mL, 1.5 mL or 2 mL). It is optimized for the application in the thermomixer as it is easier than the normal thermoracks and therefore permits higher rotational speed during mixing. It has a lower heat capacity but a faster heat transfer, i.e. it quickly reaches the desired temperature but does not retain it for long away from the temperature control.</p>	<p><i>Equip Racks + Modules with Tubes</i> (see <i>Thermoracks and thermoracks TMX</i> on p. 172)</p>
<p><b>0.5/1.5/2.0 mL rack</b></p> 	<p>The 0.5/1.5/2.0 mL rack has 24 bores. You can directly insert vessels with a volume of 1.5 mL or 2 mL, and use vessels with a volume of 0.5 mL with adapter sleeves. The 0,5/1,5/2,0 mL rack has lid holders. The lid holders are on the right, next to the bore for the vessel. The lid holder vertically clamps the tube lids. The 0.5/1.5/2.0 mL rack is transported with the gripper. The 0.5/1.5/2.0 mL rack is well-suited for use in the thermomixer.</p>	<p><i>Equip Racks + Modules with Tubes</i> (see <i>Thermoracks and thermoracks TMX</i> on p. 172)</p>
<p><b>ReservoirRack</b></p> 	<p>The ReservoirRack is used to hold a maximum of 7 reservoirs or ReservoirRack modules.</p>	<p><i>Equip Holder with Tubs + Modules</i> (see <i>Reservoirs and ReservoirRack</i> on p. 175)</p>
<p><b>Reservoirs (tubs)</b></p>  	<p>To supply liquids, reservoirs in sizes 30 mL and 100 mL are available. The ReservoirRack holds a maximum of 7 reservoirs.</p> <p>For larger volumes, an autoclavable reservoir with a capacity of 400 mL is available.</p>	<p><i>Equip Holder with Tubs + Modules</i> (see <i>Reservoirs and ReservoirRack</i> on p. 175)</p> <p><i>Tubs</i></p>

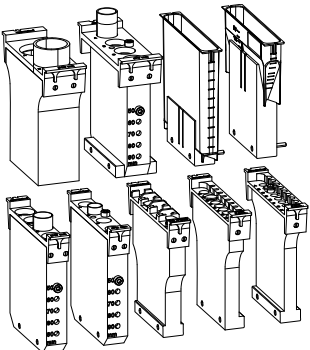
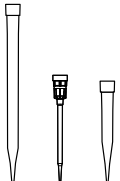
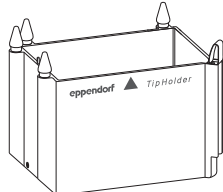
Labware	Description	Labware folder/ more information
<p><b>ReservoirRack module</b></p> 	<p>ReservoirRack Modules TC (temperature controlled) are equipped with vessels and placed in the ReservoirRack as ReservoirRack modules.</p>	<p><i>Equip Holder with Tubs + Modules</i> <i>(see ReservoirRack with ReservoirRack module on p. 176)</i></p>
<p><b>Tips</b></p> 	<p>epT.I.P.S. Motion are pipette tips for single use with the epMotion. They are available in three volume sizes to suit the dispensing tools (50 µL, 300 µL and 1000 µL), in each case with or without filter. epT.I.P.S. Motion are available as racks or reloads.</p>	<p><i>Tips</i> <i>(see epT.I.P.S. Motion on p. 169)</i></p>
<p><b>Tip holder</b></p> 	<p>The tip holder is an adapter that holds the epT.I.P.S. Motion Reloads.</p>	

### 2.4.3 Important volume terms for tubes and wells

The following remarks about volume terms are significant for selecting suitable tubes and plates and for some of the sequences when editing a method.

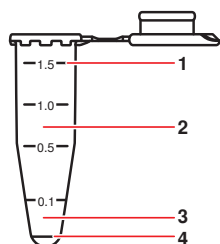

#### Filling volume

Maximum filling volume for a tube or well. A much larger volume is rejected by the software with an error message.

## Working volume

The working volume for wells is primarily in the range of 50% of max. filling volume. In the case of larger tubes, the working volume is a correspondingly larger percentage. Statements about working volume should be understood as recommendations.

Low-contamination dispensing into the well or tube is possible up to the working volume with key classes of liquid.

### MTP 96/384, PCR 96/384: fluid displacement in the working volume

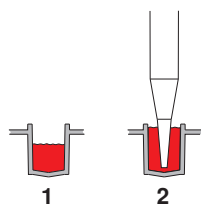

**A Well filled up to working volume**

**B Displacement if tip immersed to maximum depth before aspirating liquid**

When immersing tips in filled wells of 96-well and 384-well plates, volume displacement can cause the liquid to overflow if the optical sensor is switched off. You can avoid this by not exceeding the working volume in the wells.

To display the filling volume, click in the *Info* file window or mark the desired labware in the worktable mode.

Maximum immersion in wells is possible with all tips for 96-well plates and with 50 µL tips for 384-well plates (generally 1 mm from the bottom of the tube). To do so select in a command (**Sample Transfer, Reagent Transfer**) the corresponding *aspirate from bottom* option (see *Immersion depth and dispensing height* on p. 198).

## Remaining volume

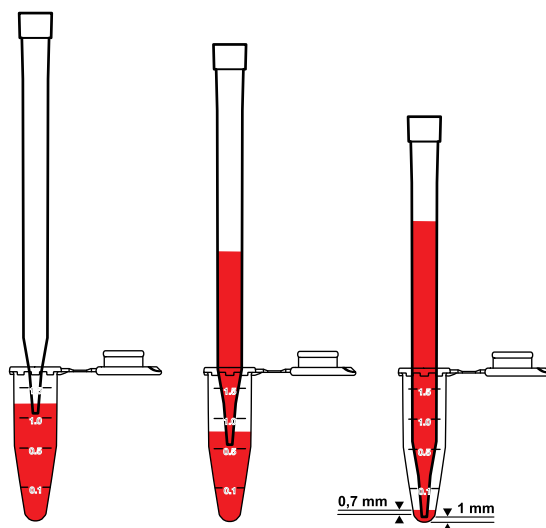

The term "remaining volume" refers to the volume which can no longer be aspirated from a tube, and which is dependent on tube geometry.

The pipette tip is generally immersed 3 mm in the liquid before liquid is aspirated. The pipette tip is moved downwards during aspiration of liquid. The immersion depth of 3 mm is maintained.

Under standard conditions, liquid can be aspirated up to the following limit data: 1.0 mm gap between the bottom of the tube and the pipette tip and simultaneously an immersion depth of the pipette tip into the liquid of 0.7 mm. The immersion depth of the pipette tip reduces at standard conditions at the tube bottom from 3 mm to 0.7 mm. The remaining volume is therefore calculated at standard conditions from a filling level of 1.7 mm.

#### Special cases for remaining volume

The initial immersion depth of 3 mm is included in the liquid type of the method. Higher immersion depths are only achieved if *Aspirate from bottom* is used. In the case of very tall tubes (e.g., primary tubes for blood), immersion to the bottom of the tube is not possible. In these cases, the remaining volume increases. There are consequently varying remaining volumes depending on tube type. Shorter 50 µL or 300 µL pipette tips and very tall tubes result in greater remaining volumes than the long 1000 µL pipette tip. Aspirations of liquid up to the remaining volume are liable to a greater risk of being incorrect. The curvature of the liquid surface could trigger falsified aspiration results.

#### Changing remaining volume

Under standard conditions the smallest distance between the pipette tip and the tube bottom is 1 mm. Exceptions are 30 mL and 100 mL reservoirs where it is 2.5 mm.



Note the comments on adjusting bottom tolerance (see *Adjusting the labware bottom tolerance on p. 93*).

---

### Multidispensing

#### Reverse stroke in multi-dispensing

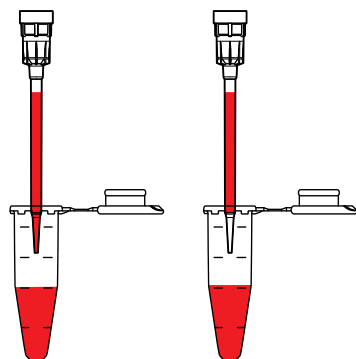

Fig. 5: Multidispense before and after reverse stroke

In multidispense, a reverse stroke takes place after aspiration of the liquid. Here the sampled liquid is returned into the source vessel. The volume of the reverse stroke is included in the aspiration volume and the required volume in the source vessel. At the start of the method, these volumes are automatically included in the calculation of volume by the software.

The reverse stroke is of equal size in all liquids, but varies according to pipette tip.



When dispensing the defined errors for pipetting are exceeded (see *Dispensing Tools on p. 159*).

---

### Extra aspiration in multi-dispensing

After the reverse stroke, there is more liquid in the pipette tip than the amount required for the dispensing steps. This extra aspiration is dispensed after dispensing is complete.

The dispensing of the extra aspiration depends on the tip change. The extra aspiration is returned to the source vessel if **no** tip change has been defined before the liquid aspiration. The extra aspiration is dispensed into the waste container if the tips are changed before each aspiration of liquid.

When water is multidispensed, the following approximate extra aspirations result for each pipette tip:

- 50 µL tips: approx. 2.5 µL extra aspiration
- 300 µL tips: approx. 5.0 µL extra aspiration (only about 3.7 µL with single-channel dispensing tool)
- 1000 µL tips: approx. 35.2 µL extra aspiration

### Aspiration volume

Aspiration volume is the volume which can be aspirated and which is required for the task in question. The volume is calculated at the start of the method from the sum of all aspirations.



In the case of multidispense, more liquid has to be aspirated for technical reasons than is calculated from the sum of all dispensing steps.

The following volumes must be available in the source vessel:

- 50 µL tips: approx. 5.8 µL extra aspiration
- 300 µL tips: approx. 45.2 µL reverse stroke (only approx. 16.7 µL with single-channel dispensing tool)
- 1000 µL tips: approx. 50.3 µL extra aspiration

The reverse stroke is the same size for all liquids.

### Example aspiration volumes with multidispense

A 96-well plate is to be filled with 10 µL water per well by the multidispense method. The eight-channel dispensing tool TM 50-8 is used. Aspiration will be completed from one reservoir. Tips are not changed before the next aspiration of liquid.

Total aspiration volumes for multidispense:

- 10 µL for 96 wells: 960 µL
- 8 x 5.8 µL reverse stroke: 46.4 µL
- 8 x 2.5 µL extra aspiration: 20 µL
- Total: **1026.4 µL**

The volume calculation of the software increases the sum total automatically by the remaining volume that cannot be aspirated from the source vessel. We do not recommend using multidispense for water before a dispensing volume of 3 µL. With small volumes, pipetting always offers better free-jet capability as well as precision and correctness. With pipetting, only the required volume is aspirated and dispensed.

### Required volume

Required volume is the total of "aspirated volume" and "remaining volume" in the tube. The minimum required volume is calculated at the start with the aid of the number of samples. For reasons of reliability (meniscus formation varies in the tubes), the "Required Volume" should always be exceeded.

## Volume check

Knowledge of the software is required to perform the volume check.

If it is known that the solution for dispensing has a density significantly different from that of water, check whether this needs to be compensated in the volume entry.

Perform the following check.

1. From the *ep* user and the *Routine* folder copy the *Fill 96* method to your user directory.
2. Adapt the copied method to your own labware.
3. Weigh the corresponding plate empty.
4. Fill the plate in the epMotion with water with the aid of the modified method.
5. Weigh the plate again.
6. Repeat the process with the liquid to be tested and another plate.
7. Use the weighing results to perform a volume calculation (mass : density = volume). The density of water at 20 °C is approx. 0.9982 mg/μL; take account of the density depending on the current temperature when converting (g/mL = mg/μL). In the case of the plate filled with water, you obtain a statement about the correctness of the dispensing tool for the selected volume. Assess the result with the test liquid accordingly, taking account of the density.
8. Depending on the result, adapt the volume in the commands. Rule of thumb: a change in density of 10% for identical dispensing conditions affects the dispensing result by between 0.2% and 1%.
9. Other physical variables (viscosity, vapor pressure, surface tension etc.) of the solution likewise affect the result.

### Volume correction after optical sensor error message

Knowledge of the software is required to perform volume correction.

If the optical sensor detects a too high or too low filling level or the (correct) filling level cannot be detected, a display appears during the Start sequence:

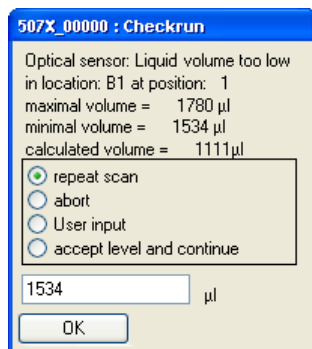

- *Maximal volume* indicates the maximum filling volume of the tube.
- *Minimal volume* indicates the required volume for aspiration based on the number of samples.
- *Calculated volume* is the volume calculated from the tube data and from measuring liquid level.

Perform the appropriate volume corrections at the tube:

- Reduce liquid if *Calculated volume* is larger than *Maximal volume*.
- Increase liquid if *Calculated volume* is smaller than *Minimal volume*.



**NOTICE!**

#### Collision as a result of volume correction or changes at the worktable.

- ▶ Perform volume correction only at the position displayed.
- ▶ Do not make any changes to the worktable.

Following volume correction at the tube, you have the following options.

- To perform Liquid Detection again, press the *Repeat scan* button and *OK*. *Repeat scan* can also be selected, for example, if the optical sensor was unable to perform a successful detection due to an air bubble in the liquid and this bubble has been removed by knocking etc. *User input* should be selected if the filling volume is below the detection limit of the optical sensor, for example. Overwrite the preset volume in the bottom input field with the correct volume and then press *OK*.
- Select *accept level and continue* if the displayed volume is to be accepted in a reagent transfer. The optical sensor then scans the next tube.
- Cancel the method. Select *abort* and then press *OK*.

If you happen to be working with several sources, see the comments in the Appendix (see *Pattern with several plates as source or destination vessels* on p. 195).

## 3 Safety

### 3.1 Intended use

The device can be used in laboratories for research, development, industrial and routine work and training and education. Applications include but are not limited to the fields of life sciences, biotechnology, chemistry, clinical research, routine diagnostics. epMotion 5070 automated pipetting systems are designed for contamination-free, precise and correct measuring and transferring of liquids. The autoclavable dispensing tools work in a volume range from 1 µL to 1000 µL. The epMotion 5070 meets the relevant fundamental requirements of the EC directives and standards listed in the declaration of conformity. epMotion 5070 automated pipetting systems are only to be used in rooms and must only be used by qualified staff with the appropriate training.

### 3.2 Information on product liability

In the following cases, the designated protection of the device may be compromised. Liability for any resulting property damage or personal injury is then transferred to the operator:

- The device is not used in accordance with the operating manual.
- The device is used outside of its intended use.
- The device is used with accessories or consumables which are not recommended by Eppendorf.
- The device is maintained or repaired by people not authorized by Eppendorf.
- The user makes unauthorized changes to the device.

### 3.3 Warnings for intended use

Read the operating manual first and observe the following general safety instructions before using the epMotion 5070.



#### Lethal voltages inside the device.

- ▶ Ensure that the housing is always closed and undamaged so that no parts inside the device can be contacted by accident.
- ▶ Do not remove the housing of the device.
- ▶ Do not allow any liquids to penetrate the inside of the housing.
- ▶ Do not allow the device to be opened by anyone except service personnel who have been specifically authorized by Eppendorf.



#### Electric shock due to damage to device or mains cable.

- ▶ Only switch on the device if the device and mains cable are undamaged.
- ▶ Only use devices that have been properly installed or repaired.
- ▶ In case of danger, disconnect the device from the mains supply.



#### Danger of explosion!

- ▶ Do not operate the device in areas where work is completed with explosive substances.
- ▶ Do not use this device to process any explosive or highly reactive substances.
- ▶ Do not use this device to process any substances which could create an explosive atmosphere.



**Damage to health due to handling infectious liquids and pathogenic germs.**

- ▶ Observe the national regulations for handling these substances, the biological security level of your laboratory, the material safety data sheets and the manufacturer's application notes.
- ▶ Wear personal protective equipment (PPE).
- ▶ Follow the instructions regarding hygiene, cleaning and decontamination.
- ▶ Comprehensive information on the regulations for handling germs and biological material in risk group II or higher can be found in the "Laboratory Biosafety Manual" (source: World Health Organization, Laboratory Biosafety Manual, in the valid version).



**Hazard when using flammable or infectious liquids.**

The waste container may contain residues of flammable or infectious liquids in ejected tips.

- ▶ If you use flammable liquids (e.g., ethanol 98%), treat the waste before disposing of it in accordance with your laboratory guidelines.
- ▶ Dispose of infectious material, waste or tips in accordance with national and local safety regulations.



**Risk from incorrect supply voltage**

- ▶ Only connect the device to power supplies which correspond with the electrical requirements on the nameplate.
- ▶ Only use sockets with a protective earth (PE) conductor and a suitable mains cable.



**Risk to health due to contaminated device.**

- ▶ Perform decontamination before storing or dispatching the device and/or its accessories.



**Poor safety due to incorrect accessories and spare parts.**

The use of accessories and spare parts other than those recommended by Eppendorf may impair the safety, function and precision of the device. Eppendorf cannot be held liable or accept any liability for damage resulting from the use of incorrect or non-recommended accessories and spare parts or from the improper use of such equipment.

- ▶ Only use accessories and original spare parts recommended by Eppendorf.



**Damage to health due to ergonomically inadequate workstation.**

- ▶ Follow the national regulations governing ergonomics of display workstations.



**Damage and corrosion from spilled liquids.**

- ▶ Disconnect the power plug if relatively large quantities of liquid are involved.
- ▶ Mop up spilled liquids immediately. When mopping up, pay particular attention to specifications in the safety data sheet.
- ▶ Do not make long-term use of chemicals which form aggressive vapors (e.g., 37% hydrochloric acid). Aggressive vapors and chemicals can cause color changes to the surface or, in the course of time, cause damage to the moving parts and electronics.



NOTICE!

**Damage to the device from the device tilting.**

- ▶ Note that during transport epMotion 5070 the center of gravity is at the back.
- ▶ Follow national safety regulations regarding the transport of heavy loads.
- ▶ Carry the epMotion 5070 using at least two people and reach underneath the device at the sides.
- ▶ Place it on an even and strong work surface epMotion 5070 of sufficient bearing capacity. The device must not be placed on a trolley or at an angle. Check that it is horizontal using a spirit level if necessary.



NOTICE!

**Damage from overheating.**

- ▶ Do not place the device close to sources of heat (e.g., radiator, drying cabinet).
- ▶ Do not expose the device to direct sunlight.
- ▶ Ensure free circulation of air by maintaining a distance of at least 6 cm from adjacent devices and the wall, on all sides of the device, and keep the underside of the device clear.



NOTICE!

**Impaired function due to vibration.**

- ▶ Do not place the epMotion 5070 on a surface with devices which generate vibration (e.g., vortex mixer, thermomixer, centrifuges).



NOTICE!

**Size of disposables can change through autoclaving.**

- ▶ Do not use autoclaved disposable products in automated applications.



NOTICE!

**Faults caused by additionally installed software.**

Temporary installed software can also cause faults.

- ▶ Only use software preinstalled by Eppendorf.
- ▶ Any additionally required software must be approved by Eppendorf.



NOTICE!

**Data loss due to lack of data backup or incorrect storage of data carriers.**

epBlue saves all information on user accounts, applications, labware and logfiles in a database on the epMotion PC. Damage to this database (e.g., due to a hardware fault) causes this information to be lost.

- ▶ Carry out regular database backups via the function *Backup* in *Admin* tab.
- ▶ Save the backup file on a secure data carrier and store it in accordance with the manufacturer instructions.

Eppendorf is not liable for data loss and its consequences.

### 3.4 Warning symbols and safety devices on the device

This section explains the warning symbols on the epMotion and the location of the safety devices.

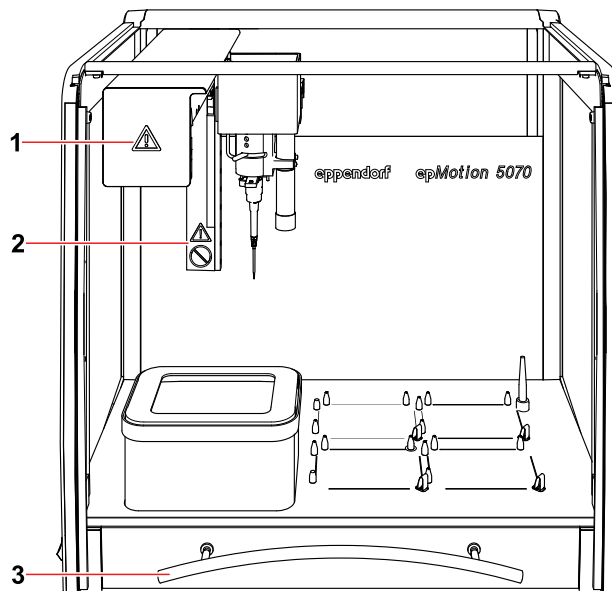



Fig. 6: Warning symbols and safety devices on the epMotion 5073

Tab. 1: Warning symbols

1		<b>WARNING</b> General hazard point. Follow the operating manual and in particular the safety notes.
2		<b>WARNING</b> The carrier may continue to move after the application has ended. Wait until the carrier has stopped moving before opening the front panel.
3		The housing protects the user from UV radiation, contamination and movable parts.

## 4 Operation



**NOTICE!**

### Damage from UV radiation.

UV radiation can cause color changes to the surface or, in the course of time, cause damage to the moving parts and electronics of the epMotion.

- ▶ Avoid UV radiation.

### 4.1 First steps

#### 4.1.1 Check correct installation

Before using the epMotion 5070 for the first time, please ensure

1. that the epMotion 5070 has been correctly connected and commissioned.
2. that the device is not damaged in any way

#### 4.1.2 Creating the first user account

In order to be able to use epBlue, an operator's user account must be configured. It is recommended that you create individual user accounts for every operator who will use the epMotion 5070.

This section describes how, as administrator, you can create the first user account. Additional information on user accounts and user groups and their administration can be found in the extensive description of the *Admin* tab (see *The Admin tab on p. 105*).

1. Start epBlue and log in as administrator (see *The Admin tab on p. 105*).
2. Go to the administrator area and click there on the *Admin* tab on the left-hand side of the program window.

Account	Personal		Telephone Number Email	Profile		
	Firstname	Company Branch		Member Of	Disabled Until	Last Login
user2	u			User Level 2	-	17.12.2009 10:55:52
				17.12.2009	-	17.12.2009 10:59:36
▶ administrator	Administrator			Administrator	-	08.01.2010 11:21:13
				08.04.2005	-	08.01.2010 10:32:55
as	as		as@eppendorf.de	Administrator Lab	-	08.01.2010 10:33:01
				17.12.2009	-	08.01.2010 11:21:04
Sophie				User Level 2	-	08.01.2010 09:59:20
				08.01.2010	20.01.2010	08.01.2010 09:59:20

3. In the left-hand area of the *Admin* tab select the *Account* entry so that it is highlighted, and then select the *Edit Account* tab.

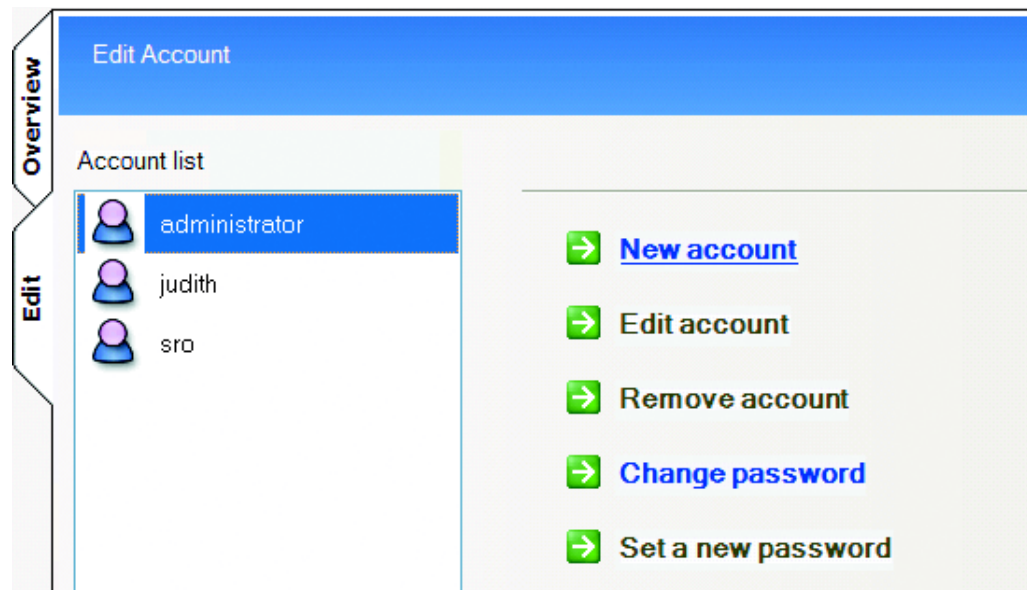

- Click on *New Account*.  
The following form is displayed.

The screenshot shows the 'Edit Account' form. On the left, there is a sidebar with 'Overview' and 'Edit' tabs. Below the sidebar is an 'Account list' containing three entries: 'administrator', 'judith', and 'sro'. The main form area contains the following fields:

- Account:** Annika \*
- Firstname:** [empty]
- Lastname:** [empty]
- Password:** [masked with dots] \*
- Confirm password:** [masked with dots] \*
- Company:** [empty]
- Branch:** [empty]
- E-Mail:** [empty]
- Telephone number:** [empty]
- Account valid until:**  4/28/2010
- Disabled until:**  4/28/2010
- Member of:**
  - Administrator \*
  - Administrator Lab
  - User Level 2
  - User Level 1
  - Guest
- Description:** [empty text area]

At the bottom right, there are 'Submit' and 'Cancel' buttons.

- In the *Account* field, enter an account name for the new user.
- In the *Password* and *Confirm password* fields, enter the password for the new user account. If the entries in the two fields do not match exactly, a message will be displayed. In this case, delete the contents of both fields and enter the password again.
- In the *Member of* section, activate the user group to which you want the new user to belong. The user will have the user rights defined for the selected group (see *Group overview on p. 114*).
- If you want to enable the account for a certain period of time, activate the *Account valid until* option and enter the expiry date there.  
You also have the option to lock the account until a certain day. To do this, activate the *Disabled until* option and enter the expiry date there.  
A disabled account can be enabled again by the administrator at a later time (see *The Admin tab on p. 105*).

9. If you wish, you can enter further information about the new user, e.g., the user's name and contact information. This information is optional. If you enter the name of the user he or she will be addressed by this name in the *Home* tab after login. Otherwise the account name will appear.
10. Click on *Submit*.  
The new user account is created. The user name appears in the Account List in the *Edit Account* tab.
11. If required, create further user accounts in the same way.
12. When you have finished, log out as administrator to prevent unauthorized access to the system.

## 4.2 Installing or replacing the dispensing tool (tool)

This section describes how to install or replace the dispensing tool required for your method.

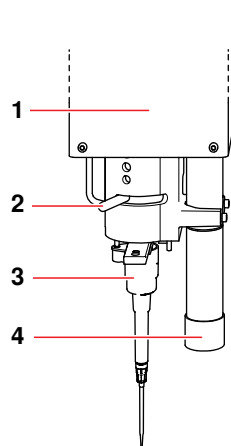

Fig. 7: Carrier with optical sensor

1 Carrier	2 Lever
3 Dispensing tool (here single channel dispensing tool)	4 Optical sensor



### Damage to the gold contacts from handling.

The connection to the PCB of the dispensing tool is interfered with or interrupted if the gold contacts on the dispensing tool are damaged or dirtied.

- ▶ Do not touch the gold contacts.

### 4.2.1 Installing the dispensing tool

Perform the following steps in the sequence described.

1. Slide the lever at the carrier all the way to the right.
2. Hold the dispensing tool in your hand and rotate it until the blue label and the volume range indication on the top bar faces you.  
The ejector pin of the dispensing tool is now on the left. In eight channel dispensing tools the channels are aligned in the Y direction (i.e. from the back to the front).
3. Slide the dispensing tool from below into the opening of the tool holder in the carrier up to the stop.
4. Slide the lever at the carrier all the way to the left. If the lever cannot be moved press the dispensing tool even harder into the opening of the carrier.



If you press too hard against the carrier when installing the dispensing tool, it can slip back. However, it does not matter if the carrier slips.

- 
5. Check the tight fit of the dispensing tool.  
The dispensing tool is now installed.



Check the tight fit of the dispensing tool regularly.

---

#### 4.2.2 Removing the dispensing tool

Perform the following steps in the sequence described.

1. Hold the dispensing tool firmly in your hand.
2. Slide the lever at the carrier all the way to the right.
3. Pull the dispensing tool all the way down.

The dispensing tool has now been removed and you can install a different one as described above.

#### 4.2.3 Notes on the dispensing sequence

Eight channel dispensing tools are only moved in the X direction (from left to right) over a 96 well plate.

During dispensing in 384 well plates eight channel dispensing tools can also execute a step in the Y direction (from the back to the front). All channels of the eight channel dispensing tool are always filled, i.e. liquid is dispensed from all channels. In the 384 well plates only every second well of a 16 well column is reached by the eight channel dispensing tool. However, using the above-mentioned Y step liquid can be added or aspired from every well in a 16 well column of a 384 well plate. Single channel dispensing tools move dependent on their program over a location in the X and Y direction.

#### 4.3 Placing labware on the worktable

This section provides you with an overview of the supply of labware on the worktable.



Beyond the preconfigured standard labware available ex works, it is also possible to dimension individual or external labware for use with the epMotion 5070 and to incorporate it in the labware directories of the software. For more information on this, contact Eppendorf Service.

---

#### 4.3.1 Position labware

Avoid placing very short labware next to very tall labware. Use a Height Adapter to compensate for the difference in height.



##### The lid lies loosely on the tip rack.

- ▶ Never grip the tip rack by its lid to lift it up, always by the side. Otherwise it will fall.
- ▶ Only take off the lid shortly before starting the method. The lid protects the tips from contamination.

1. Position the Tip Rack in the location on the worktable in accordance with the method. In the process, the Tip Rack is pressed against the stops on opposite sides by the spring plate at the location.
2. Remove the lid from the Tip Rack.
3. When using Module Racks: place the filled Reservoir Rack on a "B" location. "A" locations may not be used.
4. Position the other labware required for your method in any locations. In the process, ensure that the labware is not tilted.
5. If desired, place a waste bag in the waste container and fix in position using the clamping ring. Pull the edge of the bag tightly downwards so that the path of the dispensing tool and access to the racks is not obstructed.

#### 4.4 Starting and exiting epBlue

##### 4.4.1 Start epBlue and log in with your user account.



When the PC boots up, the epBlue server software starts automatically. If the server software is stopped while the PC is running, you must start the software manually before starting epBlue. To start the server software, select **Start - Programs - Eppendorf - epBlue Server** from the Windows Start menu.

To start epBlue, proceed as follows.



Eppendorf epBlue

1. Double-click on the **Eppendorf epBlue** icon on the desktop, or select **Start - Programs - Eppendorf - epBlue** in the Windows Start menu.  
epBlue starts, and the login screen appears.

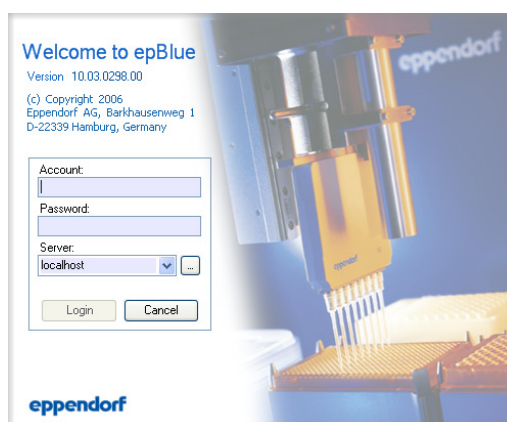

If you have forgotten your password, please contact your administrator. He can set a new password for you (see *Set up a new password on p. 113*).

Once you are logged in as a user, you can change your own password at any time. To do so, select *Tools - Account - Change Password* from the main menu.

2. Enter your account name and your password.
  3. Click on *Login*.
- epBlue starts and the program window displays the *Home* tab.

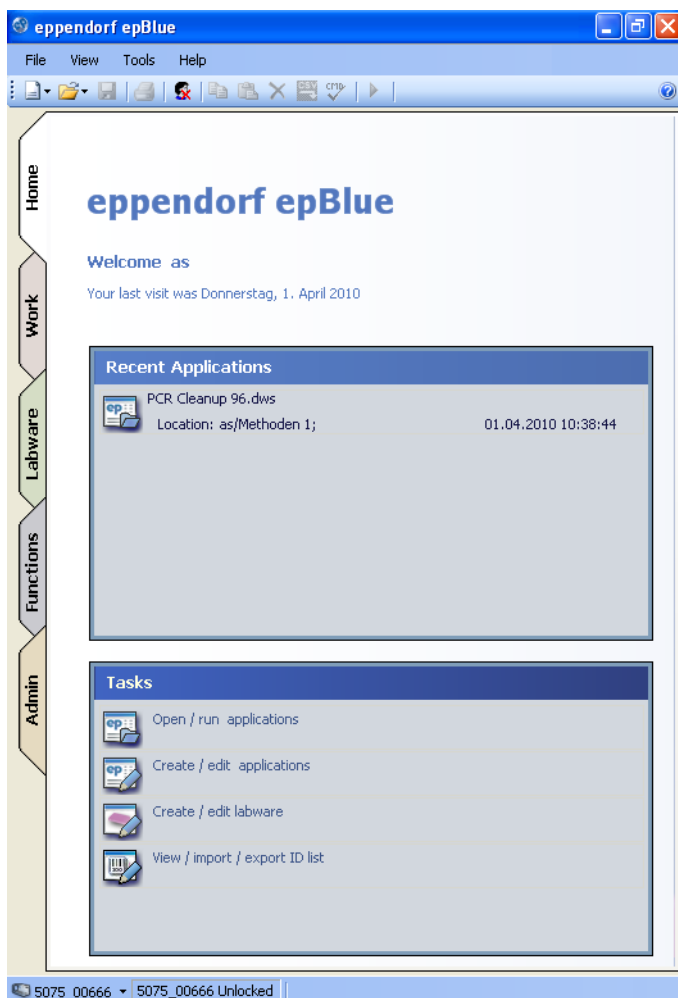

The number and type of tabs on the left hand edge of the epBlue window depends on your user rights and your epBlue configuration level.

#### 4.4.2 Logging out or exiting epBlue



You cannot log out of your account or exit epBlue while any of your applications are still running. If you need to log out or exit before your applications have finished, you must stop them manually (see *The Control tab on p. 87*).

#### Logout from your user account

To log out of your account, proceed as follows.

1. Save any changes you have made to your applications (see *Saving the current application on p. 55*) or to your labware (see *The Labware tab on p. 90*).
2. Select *Tools - Account - Log out* from the menu or click on the *Logout* button.  
You are logged out of your account.

The login screen appears. A different user can now log in.

## Exiting epBlue

To exit epBlue, proceed as follows.

1. Save any changes you have made to your applications (see *Saving the current application on p. 55*) or to your labware (see *The Labware tab on p. 90*).
2. Select *File - Exit* from the menu.  
epBlue is closed.

### 4.4.3 General information on working with ID tracking



Barcode

Only for an epMotion with barcode reader.

## Creating an application

- You can switch the ID tracking on and off for every labware positioned on the worktable. To switch on the ID tracking, set the *ID label* option of the labware to *Entry list* or *Manual scan*.
- To track the IDs in an application, switch on ID tracking for both the source labware and destination labware.
- Switch on the ID label option for each labware that you want epBlue to generate an ID list for. Sample IDs are automatically transferred through intermediate labware.
- ID tracking can only be carried out with the *Sample Transfer*, *Pool*, *Pool one Destination* and *Dilute* commands.
- For *Reagent Transfer* the IDs are not tracked, but they are documented in the log and in an input list.
- You can combine two or more samples with IDs in a destination, e.g., using a **Pool** command.

## Creating ID lists via epBlue

When the *ID label* option is switched on, epBlue creates at least one ID list for each labware in the application.

Depending on the labware type and the process carried out with the labware, the generated ID lists are stored as a *Input list* or *Result list*.

Labware type	Generated ID list
Rack with source vessels	Input list
Rack with source and destination vessels	Input list and Result list
Rack with destination vessels	Result list
Plate with source locations	None
Plate with source and destination locations	Result list
Plate with destination locations	Result list

When it comes to the creation of ID lists, intermediate positions are treated as destination positions.

Generally, epBlue creates ID lists during the application run. If you abort the application run, the ID lists only contain the entries of the positions that have been processed up to that point.

An ID list always refers to one labware. The ID list contains a list header and the following data fields for each labware position used:

Data field	Description
Position	Position number of the vessel or well. Positions are numbered line-by-line starting with 1 in the upper left position ("A1") of a plate or rack.
ID_1	ID of the vessel. For <i>Input list</i> : ID of source location. For <i>Result list</i> : ID of destination location.
ID_2	For <i>Input list</i> : empty. For <i>Result list</i> : the ID that was tracked from the source (ID of the content of the destination location).
Name	(Optional) text field for a description of the location. The <i>Name</i> data field is transmitted to the <i>Result list</i> along with the sample ID. epBlue adopts the entries for the properties of the source labware from the <i>Name</i> field if the <i>Name</i> data field is not filled in in the ID list of the source labware.

The plate ID is contained in the list header.

An ID list may contain several entries for a location. This is the case with the *Result lists* if samples with different IDs are combined in one destination location (pooled). For *Input lists*, there are 2 entries for each location if reagents with 2 IDs (e.g., one for the reagent type and one for the batch number) are used.

The ID lists are automatically saved in the epBlue database. You can export and import the ID lists in CSV or XML format.

## Run

- ID lists for source and destination labware are called *Input list* and *Result list*, respectively. You can display the lists via the list administration.
- *Input list* and *Result list* can be used with the *ID label* setting *entry list* as *Entry list* in the following runs.
- Dependent on the labware used the following information is required or issued for the ID tracking:

Labware	Plate	Rack
<b>Manual scanning</b>	Only one barcode per plate.	One barcode per tube. The rack itself does not carry a barcode.
<b>ID lists</b> <i>Input list</i> and <i>Result list</i>	One barcode per plate and one barcode per well used.	One barcode per tube. The rack itself does not carry a barcode.

**Example:** You use a plate as destination labware and have configured *manual scan*. You then must scan the barcode of the plate at the start of the method. After the method is complete you obtain a *Result list* containing both the ID of the plate and the IDs and locations of the transferred samples.

## 4.5 The Home tab



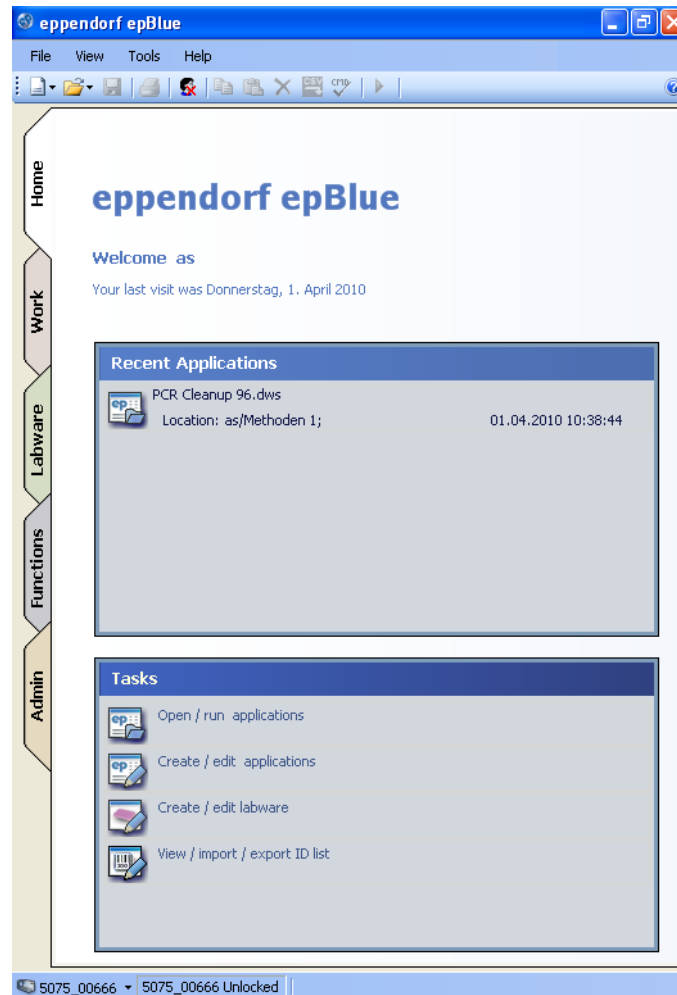

### 4.5.1 Overview of the Home tab

epBlue always starts with the *Home* tab. This tab offers shortcuts to common tasks and allows you to access your recently used applications quickly.



#### Recent applications and common tasks

In the *Recent Applications* section you will find a list of the applications you have used recently.

Recent Applications		
	Entry List Test.dws Location: as/Test PCR.dws;	17.12.2009 15:35:11
	Simple PCR.dws Location: as/Test PCR.dws;	17.12.2009 14:51:52
	Eingabe PCR.dws Location: as/Test PCR.dws;	17.12.2009 11:16:45
	10ml tubes to plate_w.dws Location: as/Test PCR.dws;	17.12.2009 11:16:11
	PCR Cleanup 96.dws Location: as/Test PCR.dws;	17.12.2009 11:14:27

In the *Tasks* section you can select the most common tasks quickly and easily. Alternatively, all tasks are also available in the main menu.

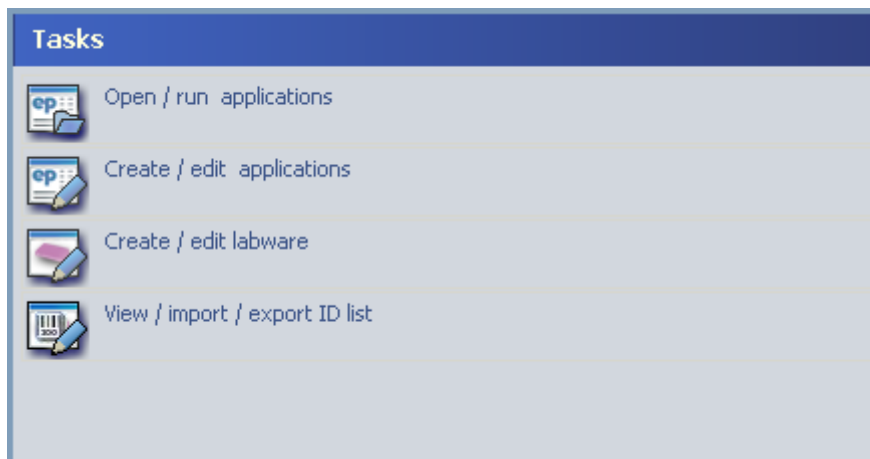

Barcode

The entry *View / import / export ID list* is only available with an epMotion with epBlue ID and barcode reader.

#### Icons in the Home tab

In the *Home* tab the following icons are available in the toolbar under the main menu.



- New... New Application: to create a new application
- Open... Open Application / Open Labware: to open an existing application or labware
- Save (not active): to save changes to applications or labware
- Print (not active): to print applications and logs
- Logout: to log out of your user account and exit the software

Alternatively, these functions are also available in the File menu.

#### 4.5.2 Open recent application



This section describes how to open those applications you have used recently. To open other applications, please refer to the section describing general file operations in the File Window (see *The file window on p. 41*).

The applications you have used recently are displayed in the *Recent Applications* list in the *Home* tab.

To open an application you have used recently, proceed as follows.

1. Click on the application in the *Recent Applications*.list.  
The application opens and the program window changes to the *Work* tab.  
You can now start or edit the application (see *The Work tab on p. 53*).

### 4.5.3 Open and manage barcode ID lists



Barcode

Only for a epMotion with epBlue ID and barcode reader.

Depending on your user rights, you can open and manage barcode ID lists.



NOTICE!

#### Data loss due to missing back-ups

The system saves ID lists in the system database.

- ▶ To avoid loss of data, save the system database regularly using the **Backup** function.

1. Click on *View/Import/export ID list* in the *Tasks* list. The *ID List Management* window opens. All the existing ID lists for your current user are displayed on the right-hand side of the window.
2. You can sort the existing lists according to date, user, type (input or result list) as well as according to the type of setting (manual or imported).  
For this, select the suitable setting from the respective fields under *View Options*.  
With the *Clear* button you can reset all the filter functions to their initial position again.  
A toolbar in the upper part allows you to view, export or delete existing lists, and to import new lists.



Import and Export is not available to guests and users with User Level 1.

- *View*: shows the barcode list as a table.
- *Import*: you can select a path to open the list to be imported and load it to barcode management. The CSV and XML formats are supported.

#### Import

1. Press *Import* in the icon bar. This opens the *Barcode Import* window.
2. Select the file to be imported by selecting the path and click on the *Open* button. The *ID List Exchange* window appears.
3. This window contains information on the imported path, the file type (CSV or XML) and the barcode with which the list is encrypted.  
Rename the list under *Name*.  
All the individual positions with the respective barcode are listed in a table below.
4. Press *Import*.  
The file is now displayed in the list of the barcode management window.

#### Export

1. Select an existing barcode list and press *Export*.
2. Select a storage location via the path, select CSV or XML as the file type and then press *Save*.  
This opens a new window containing information on the exported list.
3. Press *Export* to complete the saving process.

## Remove

- ▶ Select an existing barcode list and press *Remove*.  
The selected list is marked as deleted (only possible as Admin Lab).



When you delete an application, the ID lists which were created during the execution of this application, are also deleted.

---

## 4.6 The file window

### 4.6.1 Access to the file window

The file window allows you to open, create and edit applications, to manage your application files and folders, and to open some types of labware for editing.

The file window has two modes, depending on the way you access it: it can show either **applications** or **labware** files.

The basic procedures carried out in the file window are described in detail in the following sections.

---



To avoid loss of data it is recommended to perform regular data backups of all applications and labware files. To save data and to restore data from a previous backup, you must be logged in as an administrator (see p. 105).

---

### The file window for application files

To access the file window for **opening and running application files**, choose one of the following ways. If you open an application this way, epBlue will go directly to the *Run* tab, where you can start the application on a compatible device connected to your system.

- Click on *Open / run applications* in the *Tasks* section of the *Home* tab
- or click on the *Open* icon in the icon bar and select *Open Application*,
- or select *File - Open / run applications* from the main menu.

To access the file window for **creating or editing application files**, choose one of the following ways. Any applications you create and open this way will be displayed in the *Worktable*, where you can edit them for use in your system.

- Click on *Create / edit applications* in the *Tasks* section of the *Home* tab
  - or click on the *New* icon in the icon bar and select *New Application*,
  - or select *File - Create / edit applications* from the main menu.
- 



Further information on labware is described separately (see *Labware on p. 168*).

---

## File window for labware files

The file window for labware files shows the labware available in your system.

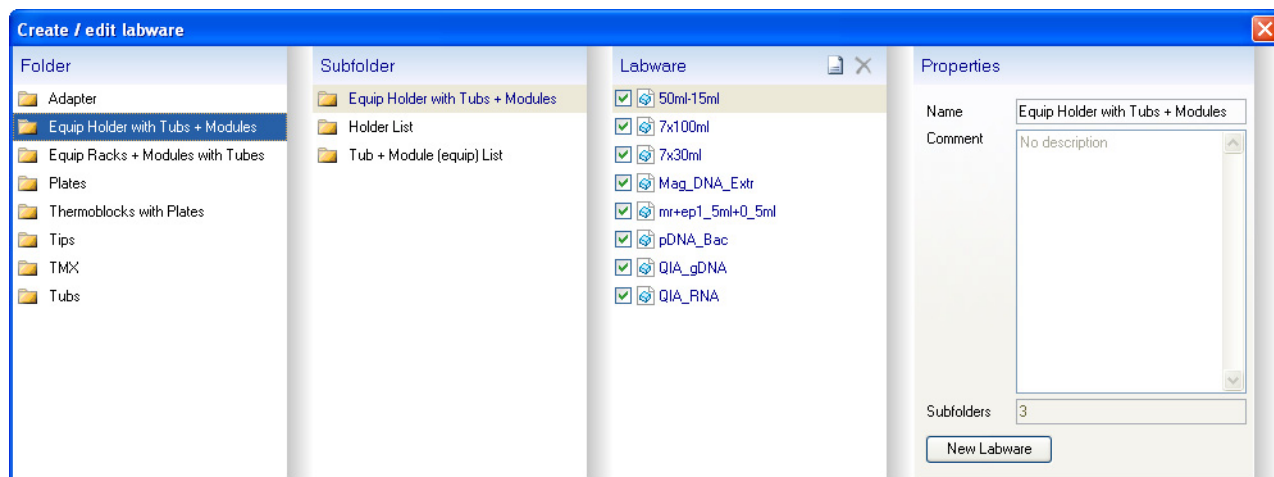

To access the file window for **opening and managing labware files**, do one of the following:

- Click on *Create / edit labware* in the *Tasks* section of the *Home* tab
- or click on the *Open* icon in the toolbar and select *Open Labware*,
- or select *File - Create / edit labware* from the main menu.

### 4.6.2 Opening an application

To open an application that you want to run on a device, proceed as follows.

1. Open the file window (see *Access to the file window on p. 41*).
2. Select a user name in the user list on the left-hand side to gain access to this user's directory (usually your own).  
The folders in the selected user directory are now displayed in the *Folder* list.
3. In the *Folder* list select the folder containing the required application.  
The applications in the selected folder are now displayed in the *Applications* list.
4. In the *Applications* list select the application you want to open.  
The properties of the selected application are displayed on the right-hand side.

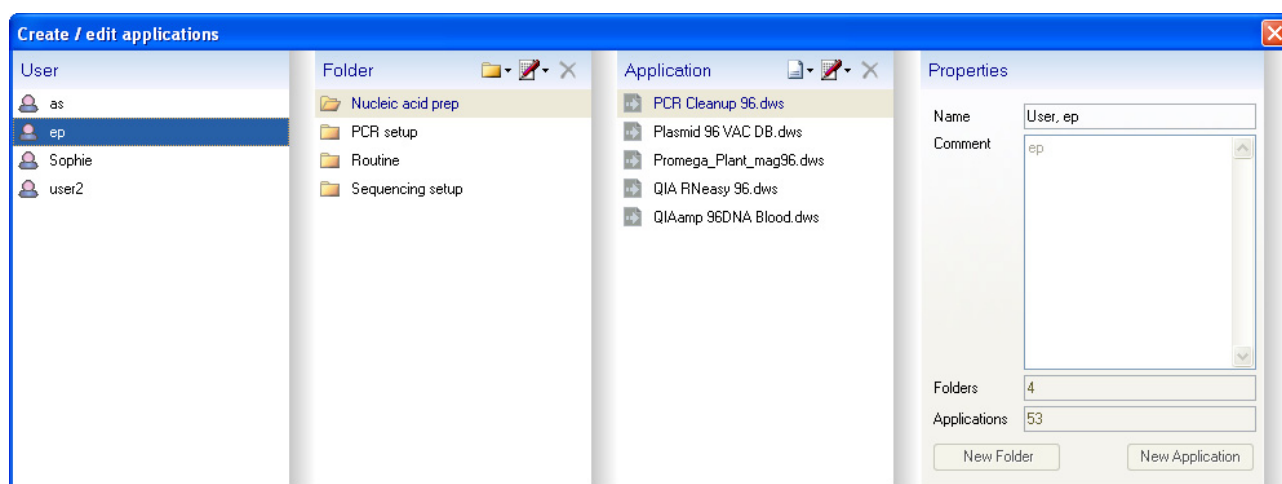

- To open the selected application, click on *Open Application*.

The application opens and epBlue goes to the *Work* (see *The Work tab on p. 53*) tab.

If you opened the application via the *Open / run applications* command, epBlue goes directly to the *Run* tab, where you can start the application on a device connected to your system.

If you opened the application via the *Create / edit applications* command, epBlue switches to the *Worktable*, where you can edit and run the application.

Applications from other user folders are automatically opened in read-only mode and cannot be started. You first have to copy the applications to your own user folder to be able to edit and run them (see p. 46).



In the *Applications* list open applications are displayed with a lock.

### 4.6.3 Creating a new folder in your user directory

Your user directory contains the applications that you can edit and run on the available devices. To organize your applications, you can store them in folders which you create in your user directory.

To create a new folder in your user directory, proceed as follows.

- Open the file window (see *Access to the file window on p. 41*).
- Select your user name in the *User* list on the left-hand side to gain access to your user directory.

All folders in your user directory are now displayed in the *Folder* list.

The properties of the selected user directory are displayed on the right-hand side.

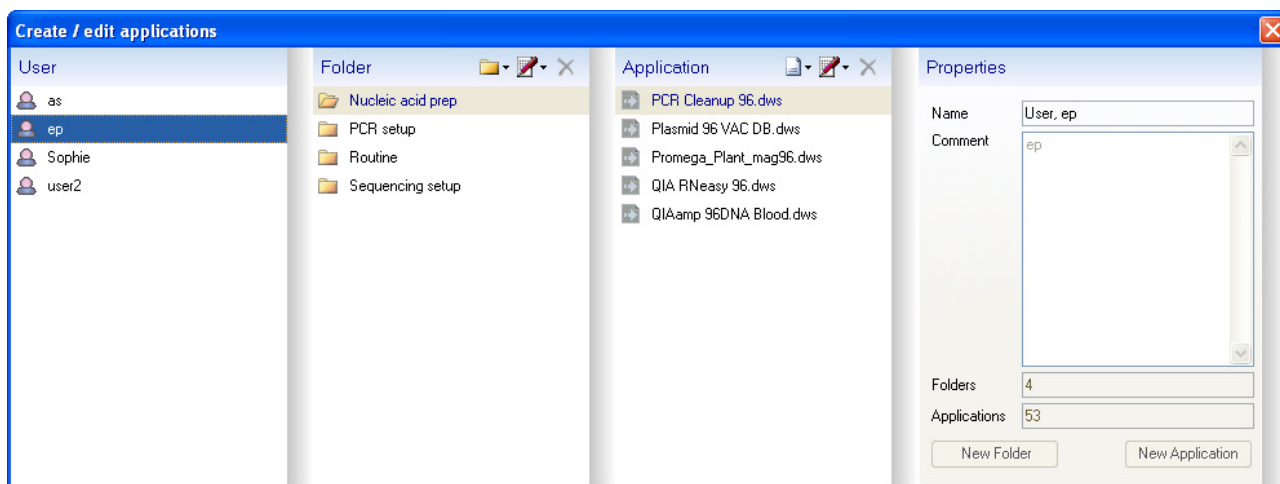

- To create a new folder click on *New Folder* or click on the *Create new folder* icon above the *Folder* list.

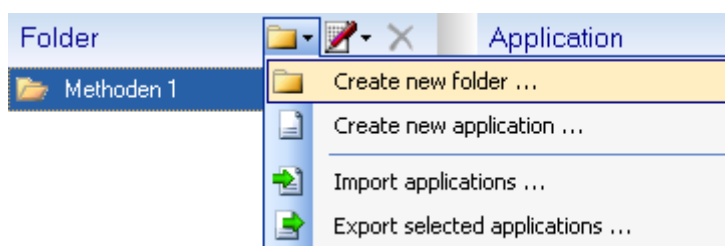

A dialog window opens.

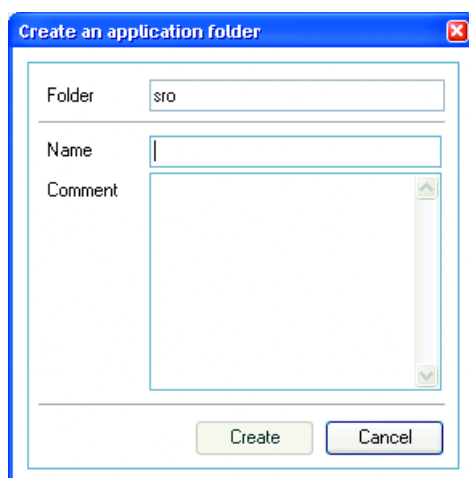

4. Enter a name for the new folder. If required, enter a short description of the folder in the *Comment* field.
5. Click on *Create*.

The new folder has been created and is displayed in the *Folder* list.

#### 4.6.4 Creating a new application



This section describes how to create a new empty application. Alternatively, you can duplicate an existing application (see *Duplicating an open application on p. 54*) and edit the duplicate. This allows you to create several similar applications quickly and efficiently.

This function is only available if you have the necessary user rights.

To create a new application, proceed as follows.

1. Open the file window (see *Access to the file window on p. 41*).
2. Select a user name in the user list on the left-hand side to gain access to this user's directory (usually your own).

The folders in the selected user directory are now displayed in the *Folder* list.

The properties of the selected user directory are displayed on the right-hand side.

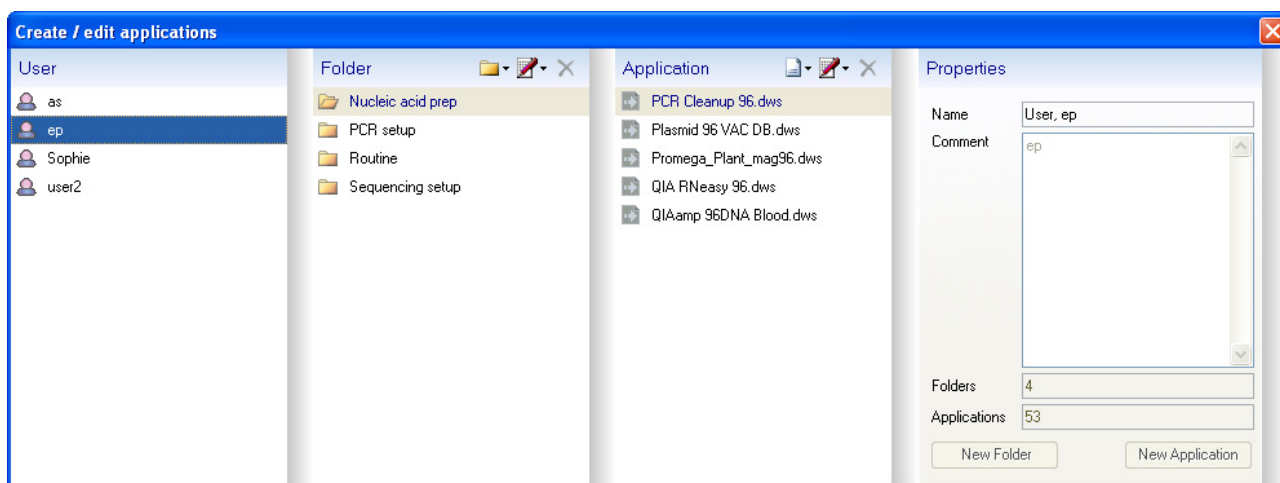

You can create a new application either in the top level of the user directory, or in a folder within the user directory.

- To create a new application at the top level of the user directory, check that the user has been selected in the *User* list, then right click in the *Applications* list and select *New Application* in the context menu or click on the *Create new application* icon above the *Applications* list.



- To create a new application in a **folder within the user directory**, select the folder in which you want to create the new application.  
The applications in the selected folder are now displayed in the *Applications* list.  
The properties of the selected folder are displayed on the right-hand side.

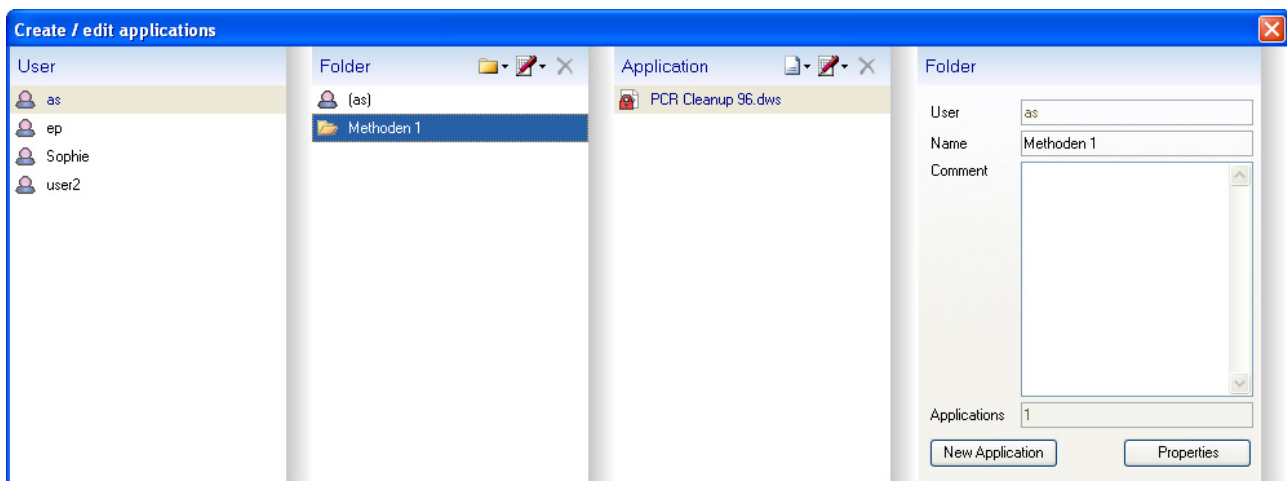

- To create a new application in the selected folder, click on *New Application* in the properties section, or right-click in the *Applications* list and select *New Application* from the context menu, or click on the *Create new application* icon above the *Applications* list.



A dialog window opens.

- Enter a name for the new application. If required, enter a short description of the application in the *Comment* field.
- Click on *Create*.  
The new application has been created and is displayed in the *Applications* list.

If you have created the application at the top level of the user directory, the user directory is now also included in the *Folder* list. Its name displayed in brackets.

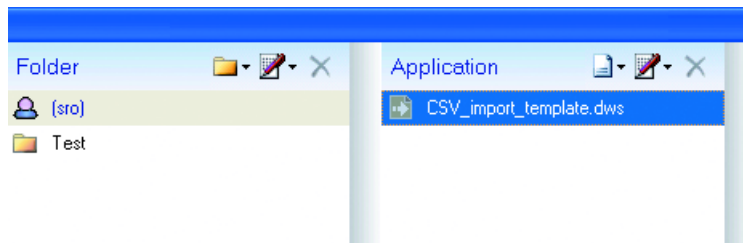

You can now open the new application (see *Opening an application on p. 42*) and edit it in the *Work* tab (see *The Work tab on p. 53*).

#### 4.6.5 Copying applications and folders from other user directories to one's own

The **ep** directory contains standard Eppendorf applications. These applications and all applications in other user directories are read-only and cannot be edited or started directly. However, you can copy them to your own directory in order to edit them or to run them on a device. In the same way, you can copy existing applications from other user's directories and adapt them to your own requirements.

To copy an application or folder from another user's directory to your own, proceed as follows.

1. Open the file window (see *Access to the file window on p. 41*).
2. In the *User* list select on the left-hand side the user directory containing the application or folder you want to copy.  
The folders in the selected user directory are displayed in the *Folder* list.
3. **To copy a folder**, select the folder in the *Folder* list, click on the *Edit Folder* icon above the *Folder* list and select *Copy* or right click on the folder and select *Copy* in the context menu.  
The folder is copied into the computer clipboard.
4. **To copy an application**, select the folder which contains the required application.  
The applications in the selected folder are now displayed in the *Applications* list.
5. In the *Applications* list select the application you want to copy.  
The properties of the selected application are displayed on the right-hand side.
6. Click on the *Edit Folder* icon above the *Applications* list and select *Copy*.

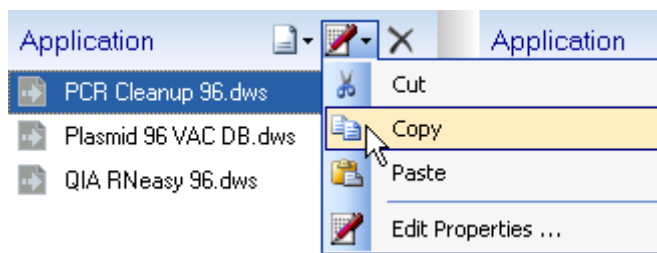

7. In the *User* list select on the left-hand side your own user directory.
8. **To insert a copied folder into your user directory**, click on the *Edit Folder* icon above the *Folder* list and select *Paste*.  
The copied folder is inserted into your user directory.
9. **To insert a copied application**, select the folder into which you want to insert the application.  
The applications in the selected folder are now displayed in the *Applications* list.

10. Click on the *Edit Folder* icon above the *Applications* list and select *Paste*.

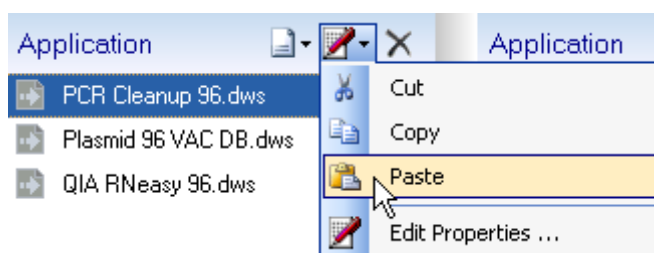

The copied application is inserted into the selected folder in your own user directory.

You can now run or edit the application or applications in the copied folder (see *The Work tab* on p. 53).



If the worktable of the copied application does not match that of the connected epMotion, you will not be able to execute the application. In this case, save the application with *Save as...* under a new name with the suitable worktable.

#### 4.6.6 Editing folder and application properties

To edit the properties of a folder or application, proceed as follows

1. Open the file window (see *Access to the file window* on p. 41).
2. To edit the properties of a folder select the folder in the *Folder* list.
3. To edit the properties of an application select it in the *Applications* list.

The properties of the selected folder or application are displayed on the right-hand side.

4. Click on *Properties*.

A dialog window opens. You can now edit the following properties.

- Name: The name of the folder or application.
- Comment: A short description of the folder or application.
- Read only (for applications): If this option is active, the application can be opened and started, but it cannot be edited, to protect it against accidental changes.

You can also call the properties via the **Cut+Copy+Paste** button.

5. To save the changes, click on *Save*.
6. To exit the properties without changes, click on *Cancel*.

#### 4.6.7 Deleting applications and folders



Barcode

If you delete an application with ID tracking activated, all the ID lists which were created when the application was executed will also be deleted.

You can delete applications and folders from your own user directory. The applications and folders in the **ep** directory cannot be edited or deleted.

To delete applications or folders, proceed as follows.

1. Open the file window (see *Access to the file window on p. 41*).
2. To delete a folder select the folder in the *Folder* list and click on the *Delete* icon above the *Folder* list.

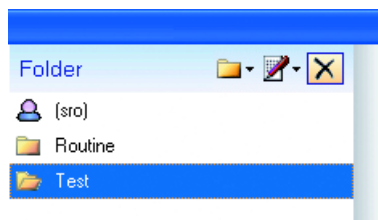

3. To delete an application select it in the *Applications* list and click on the *Delete* icon above the *Applications* list.

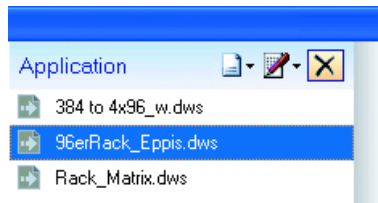

A warning message appears.

4. To confirm, click on *Yes*.  
The selected folder or application is deleted.

#### 4.6.8 Import applications

You can import applications from your hard disk or from a USB storage device into epBlue. The following file formats can be imported:

- method files for epMotion (file extension \*.dws)
- older method files (file extensions \*.ws or \*.lhs)
- Files exported with epBlue (file ending \*.export)

To import applications, proceed as follows:

1. Open the file window (see *Access to the file window on p. 41*).
2. Select the target directory and click on the *Import Applications* icon above the *Folder* list.

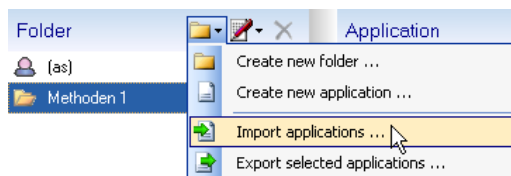

3. Alternatively click on the *Import Applications* icon above the *Applications* list.

The import window opens.

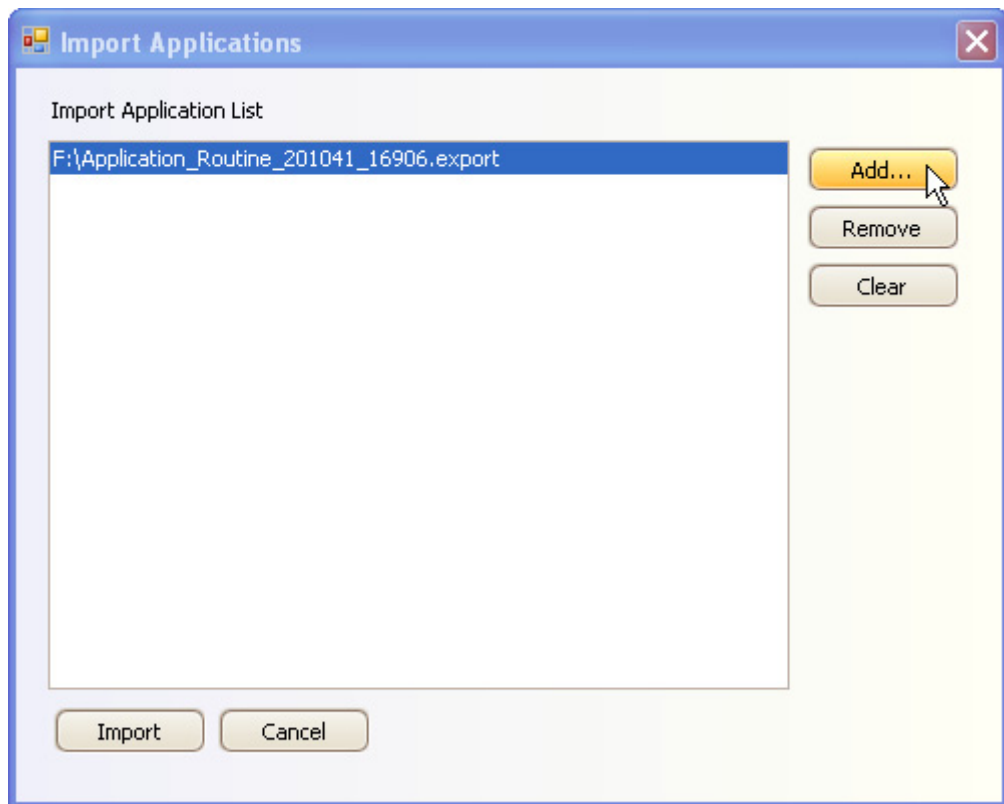

4. Click on *Add* and select the files you want to import from your hard disk or USB storage device.

The selected applications are listed in the import window.

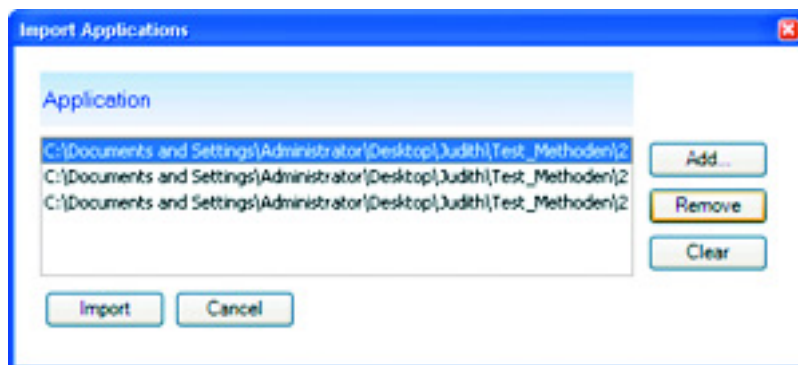

5. Click on *Remove* to remove individual files from the selection list. Click on *Clear* to clear the selection list.
6. Click on *Import*.  
Another import window opens. The target folder and the corresponding user are specified again at the top of the page. All the files to be imported are listed and automatically selected.
7. Deselect the files which should not be imported.
8. Click on *Import*.

The applications are imported into eBlue. An import summary appears in a window.

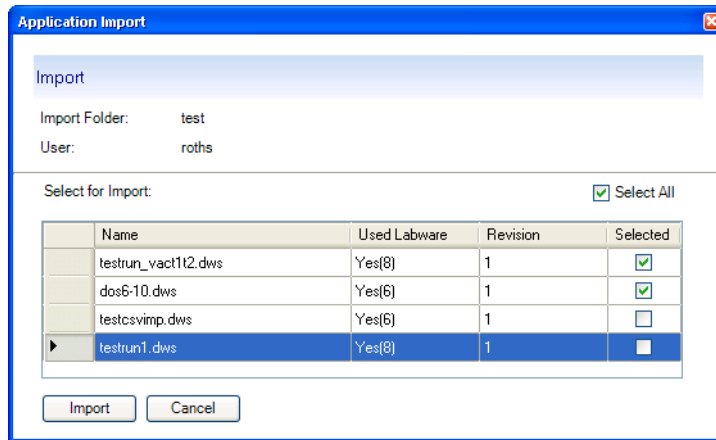

9. Click on *Finish* to complete the process.



If you import applications from older software versions, it may happen that the way the worktable is displayed in epBlue does not corresponds to your device configuration. Save the application with *Save as* under a new name to resolve this problem.

#### 4.6.9 Exporting applications

You can export application files to your hard disk or to a USB storage device.

To export applications, proceed as follows.

1. Open the file window (see *Access to the file window on p. 41*).
2. To export all applications to a folder select the folder in the *Folder* list and click on the *Export Selected Applications* icon above the *Folder* list.

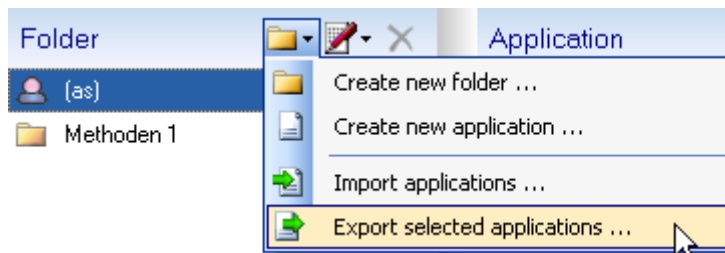

3. To export an individual application select the application in the *Applications* list and click on the *Export Selected Application* icon above the *Applications* list.
4. Select a target folder for the application files, click on *OK* and confirm the message in the new window with *export*. In this window you can deselect the files again and re-enter the target folder in the upper part.

The files are exported to the specified folder. An export summary appears in a window.

5. Click on *Finish* to complete the process.



The required labware for applications is also imported.



Exported epBlue applications cannot be used for the control panel.

Methods and labware exported from this epBlue version cannot be imported into older epBlue versions (10.x).

#### 4.6.10 Open labware for editing

This section describes how to open a labware file in the file window. For a more detailed description of the editing steps and labware types that can be edited see the description of the *Labware* tab (see *The Labware tab on p. 90*).

The import and export of labware files is described elsewhere (see *Importing and exporting labware combinations on p. 221*).



This function is only available if you have the necessary user rights.

To open labware for editing, proceed as follows.

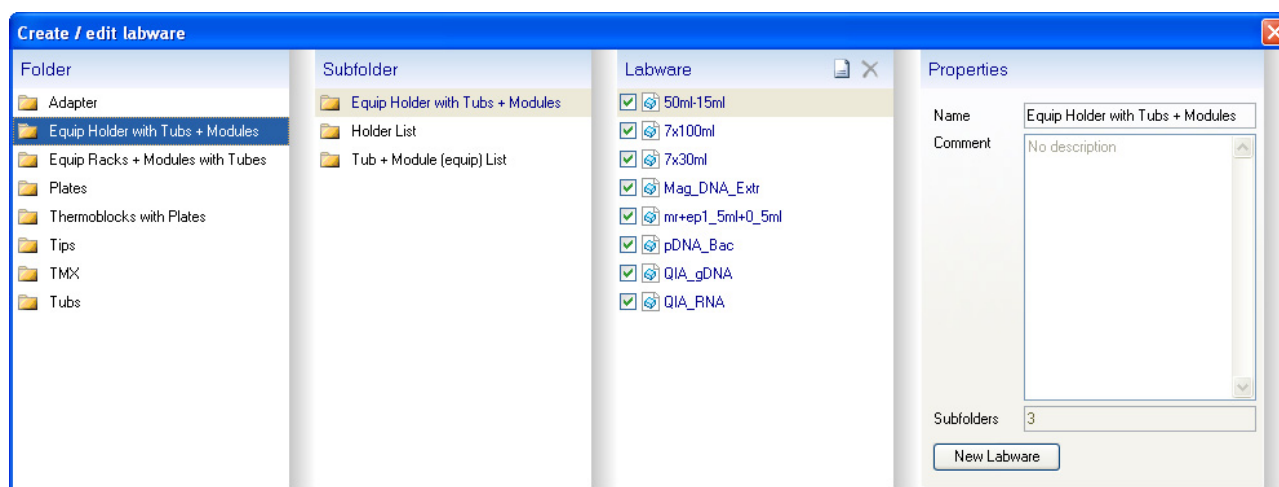

1. Open the labware file window (see *Access to the file window on p. 41*).
2. In the *Folder* list on the left-hand side select the labware folder containing the labware you want to edit.  
If there are subfolders, these are displayed in the *Subfolder* list.
3. If required, select the subfolder.  
The labware in this folder is displayed in the *Labware* list.
4. In the *Labware* list select the labware you want to open.  
The properties of the selected labware are displayed on the right-hand side.
5. To open the selected labware, click on *Open Labware*.  
The labware opens and the program window changes to the *Labware* tab.

You can edit the labware, or create new labware or labware combinations for use in your applications. You can equip racks or modules with tubes (see p. 95), and you can equip reservoir racks with various reservoirs and equipped modules (see p. 98).

#### 4.6.11 Deleting a labware combination



Depending on your user rights, you can delete labware combinations created by yourself or by other users in your system. Labware identified in the *Labware Properties* section as *Eppendorf Standard Labware* cannot be deleted.

To delete a labware combination you have created, proceed as follows.

1. Open the labware file window (see *Access to the file window on p. 41*).

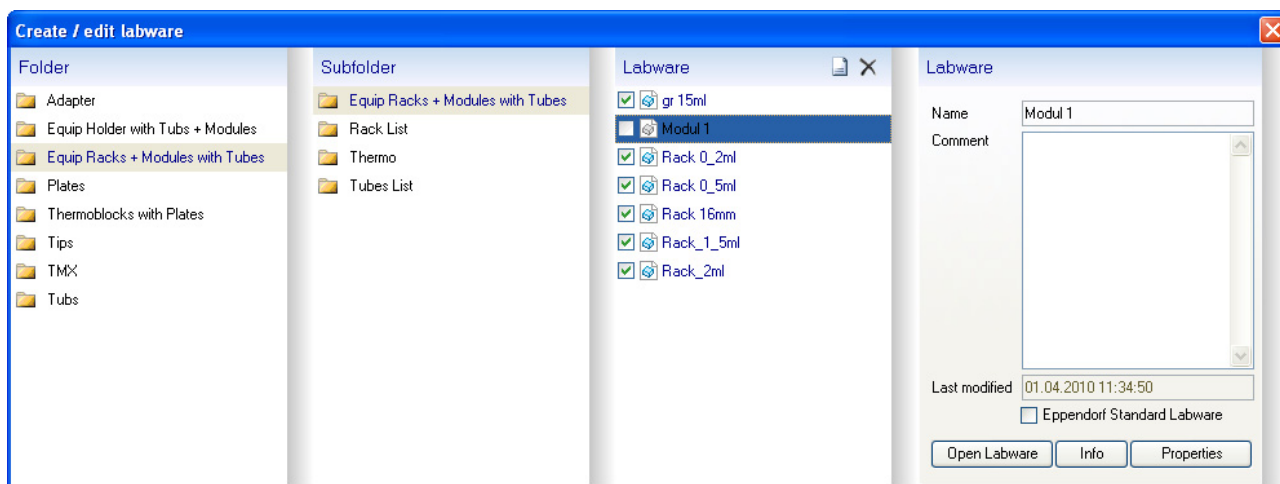

2. In the *Folder* and *Subfolder* lists select the labware folder containing the labware you want to delete.  
The labware in this folder is displayed in the *Labware* list. Eppendorf Standard Labware is displayed in blue, it cannot be deleted.
3. Select the labware you want to delete and click on the *Delete* icon above the *Labware* list.  
A warning message appears.
4. To confirm, click on *Yes*.  
The labware is deleted.

## 4.7 The Work tab

### 4.7.1 Overview of the Work tab



If the *Work* tab is empty when opened, you first have to open an application via the *Home* (see *The Home tab on p. 38*) tab or the file window. (see *Opening an application on p. 42*)

epBlue automatically changes to the *Work* tab if you have opened an application via the *Home* tab or the file window. You can also access the empty *Work* tab by clicking with the mouse. In the *Work* tab you can edit your own applications and start them on the available devices.

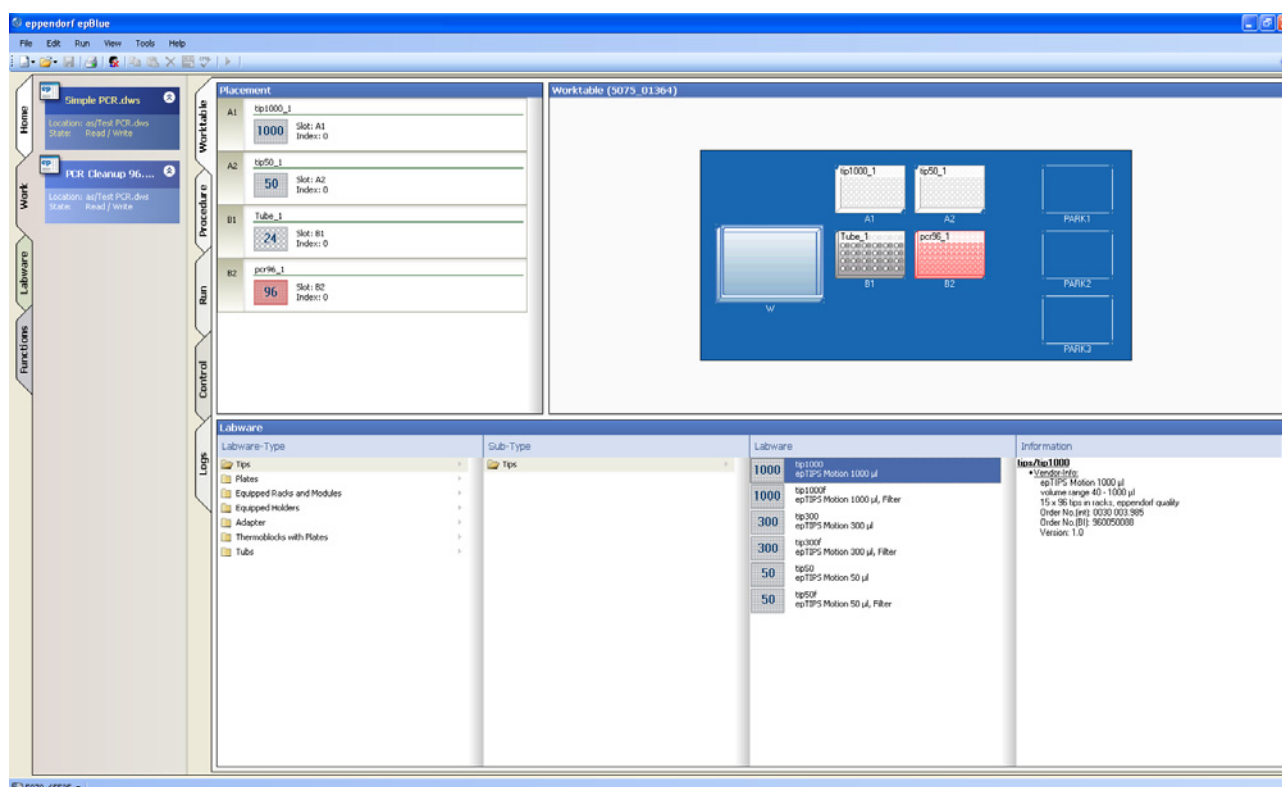

#### List of open applications

On the left-hand side of the *Work* tab a list with all open applications is displayed. Several applications can be open at the same time and can be edited or run in parallel. The current application is highlighted. To switch between the applications, click on the application names in the list.

#### Tabs for editing and running epMotion-applications (methods)

If you have opened a method (i.e. an application for epMotion), the *Work* tab displays several tabs:

- *Worktable*: In the *Worktable* tab you equip your worktable with the labware required for the method (see *Worktable tab - equip the worktable on p. 58*).
- *Procedure*: In the *Procedure* tab you define the sequence of the commands to be executed when the method is run (see *Procedure tab - defining a procedure on p. 63*).
- *Run*: With the *Run* tab you can start your method on one or several devices available in your system (see *The Run tab on p. 80*).
- *Control*: In the *Control* tab you can monitor and control the devices on which your method is currently running (see *The Control tab on p. 87*).
- *Logs*: In the *Logs* tab you can view and print the logs of the respective method.

### Icons in the Work tab for epMotion applications (methods)

When you have opened a method (i.e. an application for epMotion), the *Work* tab displays the following icons in the toolbar below the main menu.



- **New... New Application:** to create a new application for editing
- **Open... Open Application/Labware:** to open an existing application/labware
- **Save:** to save changes to your methods
- **Print:** to print a report
- **Logout:** to log out of your user account and exit the software
- **Copy** (only active in the *Procedure* tab): to copy objects (commands) to the clipboard of the computer.
- **Paste** (only active in the *Procedure* tab): to insert objects (commands) from the clipboard of the computer.
- **Delete** (only active in the *Procedure* tab): to delete a selected object (command).
- **CSV Import** (only active in the *Procedure* tab): to import commands from a CSV file to the Procedure.
- **Check Method** (only active in the *Procedure* tab): to check method parameters.
- **Start Method:** to start a method on a device.

Alternatively, these functions are also available in the **File** menu.

Additional information on the selection of tasks, e.g., opening or creating methods or managing method files and folders, can be found in the detailed description of the *Home* (see *The Home tab on p. 38*) tab and in the file window (see *The file window on p. 41*).

### Duplicating an open application

If an application is read-only or is running on a device, it is protected and cannot be edited. However, you can create a duplicate which you can edit.

To create a duplicate of an open application, proceed as follows.

1. Select the application in the list of open applications on the left-hand side.
2. Right-click on the application name and select *Duplicate* from the context menu.

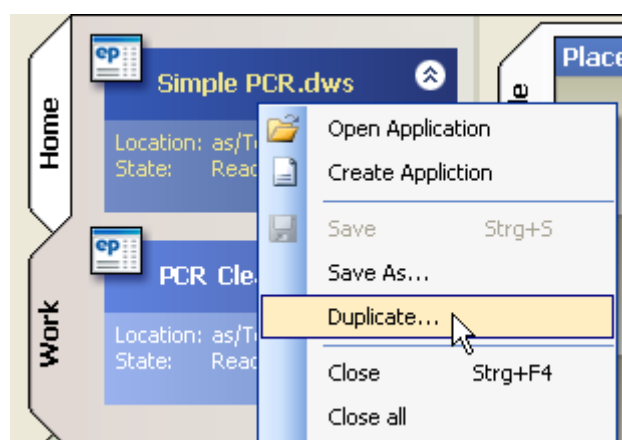

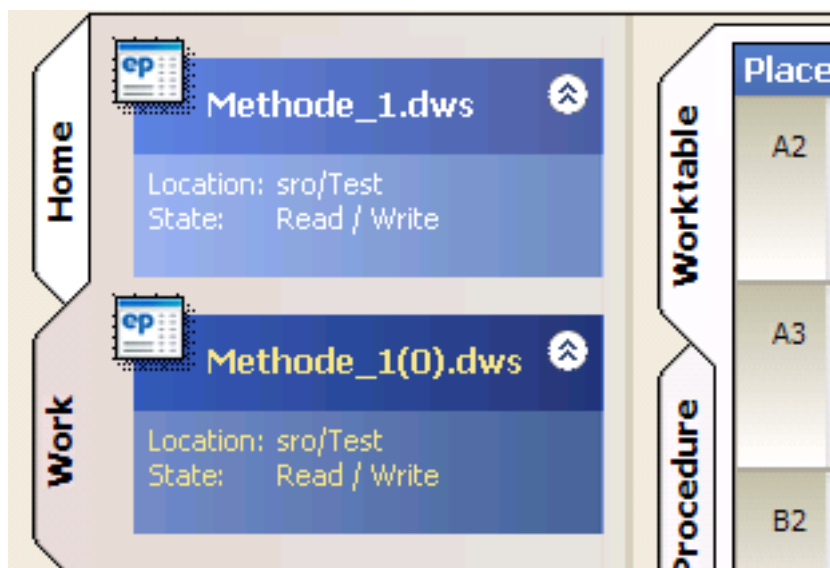

The duplicate application is created and displayed in list of open applications. The file name of the duplicate application is a copy of the name of the original application file plus a number in brackets. If you create more than one duplicate of the same original application, the duplicates are numbered consecutively.

You can now open the duplicate application or edit its properties (see *The file window on p. 41*).

### Saving the current application

To save the current application, proceed as follows.

1. Select the application in the list of open applications on the left-hand side of the *Work* tab. The current application is highlighted in darker blue.
2. To save the application under the same name, click on the *Save* icon, or select *File - Save* from the main menu, or right-click on the application name and select *Save* from the context menu.

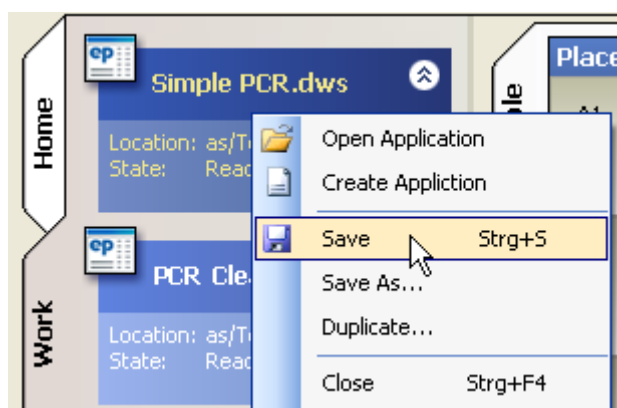

3. To save the application under a new name, select *File - Save As* from the main menu, or right-click on the application name and select *Save As* from the context menu.

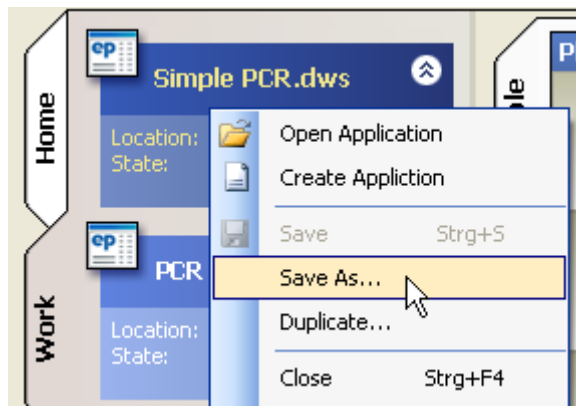

A dialog window opens.

4. Enter a file name and click on *Save*.  
The application is saved in your user directory.

### Printing applications and logs

You can print a description of the current application, e.g., the worktable assignment and procedure of commands defined in a method.

When the application has been executed on a device connected to your system, you can also print the logs of every individual run. The logs record every program step carried out by the device (see *Reading logs on p. 88*).

To print an application or its logs, proceed as follows.

1. Select the application in the list of open applications on the left-hand side of the *Work* tab.  
The current application is highlighted. To print the method, select the worktable. To print a log of the method, select the *Logs* tab.
2. Click on the *Print* icon, or select *File - Print* from the main menu.
3. The Preview window opens.



In the Preview window, the following icons are available (from left to right):

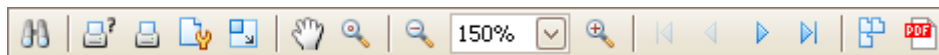

- **Search:** to search the document text.
  - **Print:** to select a printer and print the document.
  - **Quick Print:** to print the document on the standard printer configured in your system.
  - **Page Setup:** to change the page setup before printing.
  - **Scale:** adjust the size of your printout here.
  - **Hand Tool:** to navigate by dragging the document up or down with the mouse.
  - **Magnifier:** to toggle the zoom factor between 100% and full-page view.
  - **Zoom / Zoom Out / Zoom In:** to adjust the zoom factor.
  - **First / Previous / Next / Last Page:** to navigate through the document pages.
  - **Multiple Pages:** to specify the number of pages displayed in the Preview window.
  - **PDF:** to save the printout as a PDF in a folder you have selected.
4. Print or save the document as required, using the icons in the Preview window, as described above.
  5. To exit the preview, close the Preview window.

#### 4.7.2 Worktable tab - equip the worktable

In the *Worktable* tab you equip worktable of the epMotion with the labware required for the method.

To go to the *Worktable* tab select the *Work* tab on the left-hand side of the program window and select the *Worktable* tab.

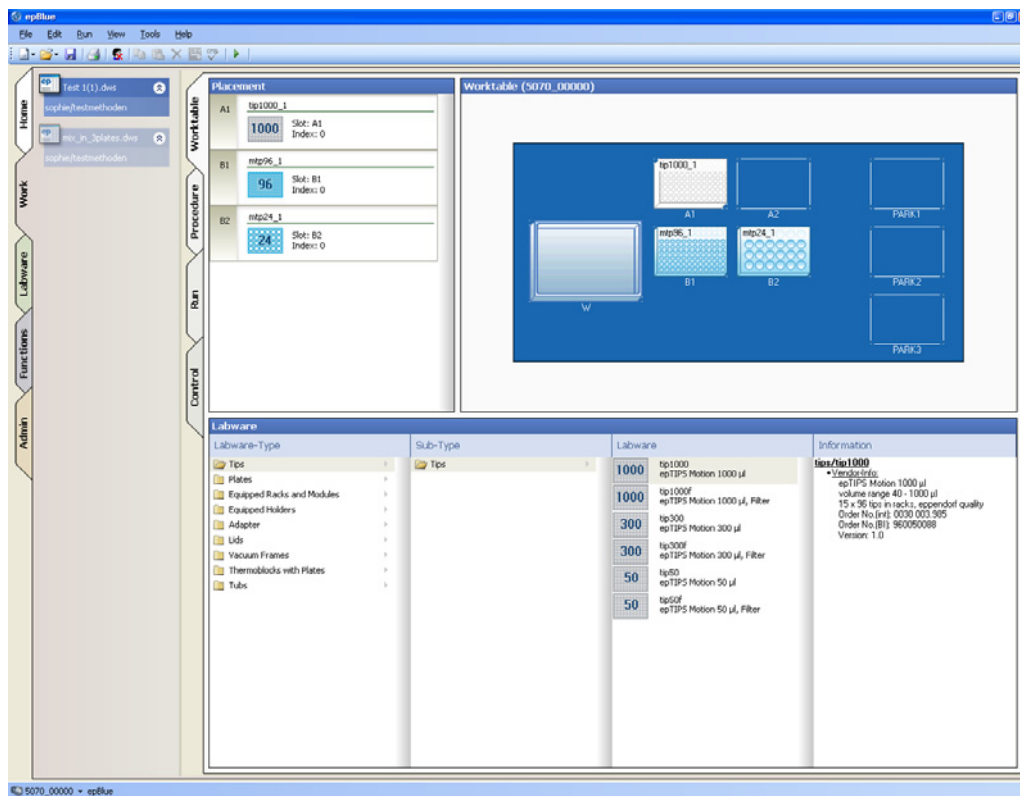

The *Worktable* tab is divided into 3 sections.

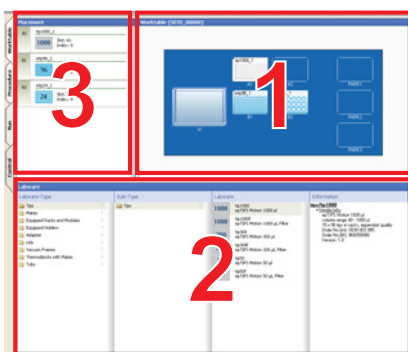

The *Worktable* (section 1) is displayed in the top right section of the *Worktable* tab. It shows the worktable assignment for the active method. You can edit the worktable with the mouse, add and remove labware or move labware to a different location on the worktable.

The *Labware* list (section 2) is displayed in the bottom section of the *Worktable* tab. It contains the available labware that you can place on the worktable.

The *Placement* list (section 3) is displayed in the top left section of the *Worktable* tab. It shows a list of all occupied worktable locations and the labware placed at each location.

### Positioning labware on the worktable

To position labware on the worktable, proceed as follows.

1. In the *Labware Type* list select the type of labware you want to use (e.g., "Plates").  
If there are subgroups they are displayed in the *Sub-Type* list.
2. In the *Sub-Type* list select the subgroup you want to use (e.g., "mtp96").  
The available labware of this type is displayed in the *Labware* list.
3. In the *Labware* list select the labware you want to position on the worktable (e.g., "CO\_MTP\_360\_1").  
Some information on the selected labware is displayed on the right-hand side.

Labware-Type	Sub-Type	Labware	Information
Tips	DWP 384	96 CO_MTP_360_1 Corning/Costar 96 Well Plate Without Lids	<b>plates/mtp96/CO_MTP_360_1</b> • Vendor Info: Corning/Costar 96 Well Plate Without Lids Description: U-bottom, FP Order No.: 3385 Maximal filling volume: 270 µl Working volume: 200 µl Detection limit optical sensor: 70 µl Version: 1.0
Plates	DWP 96	96 CO_MTP_360_2 Corning/Costar 96 Well Assay Plate	
Equipped Racks and Modules	Filter Plates 384	96 EP_µDNA_96_MTP Eppendorf 96 Well Elution Plate with	
Equipped Holders	Filter Plates 96		
Adapter	MTP 24 + DWP 24		
Lids	MTP 384		
Vacuum Frames	MTP 6		
Thermoblocks with Plates	MTP 96		
Tubs	PCR 384		
	PCR 96		
	Tube Plates 96		

4. To position the labware on the worktable, press the left mouse button and keep it pressed, dragging the labware upwards from the list.



While you are dragging the labware, it is attached to the mouse pointer by its upper left-hand corner. To position the labware on the worktable, direct the mouse pointer (not the center of the labware icon) to the intended location. The mouse pointer carries a small "+" (plus) symbol if the labware can be positioned at the current location.

5. Drag the labware to its intended location on the worktable and drop it there by releasing the mouse button.

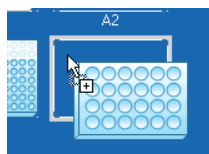

A dialog window opens which allows you to change the settings for this labware.

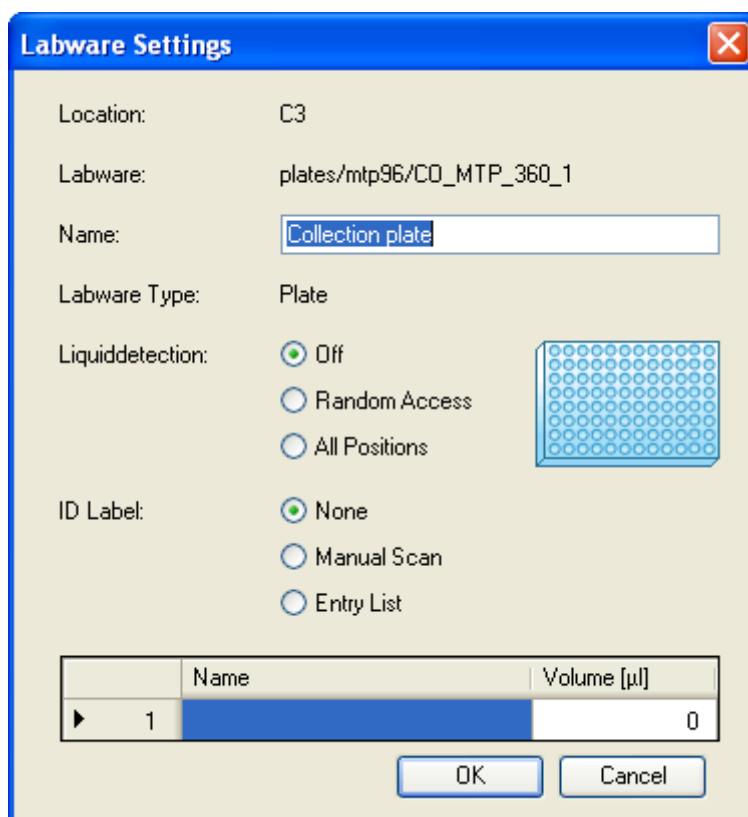

6. If required, edit the name of the labware in the *Name* field.
7. If the optical sensor is to perform liquid detection at this location during the method, then set the desired option.

The following options are available:

- *Off*: Liquid detection is switched off at this location. If you use this option, click in the Volume field and specify a volume for the labware.
- *Random Access*: The optical sensor performs liquid detection at a few randomly-selected positions of this labware.
- *All Positions*: The optical sensor performs liquid detection at all positions of this labware. It is not recommended to select this option for racks and plates with 96 positions, as this is time-consuming.

If required, you can always edit these settings again later (see *Editing labware properties on the worktable on p. 62*).

8. Only for an epMotion with epBlue ID and barcode reader: You can select whether a barcode ID should be assigned to the labware. There are 3 ways of doing this:
  - *Manual scan*: In the *Run* section you will be requested to manually read the used positions with the barcode reader.
  - *Entry list*: In the *Run* section you will be requested to select an already existing barcode list for the allocation. For control purposes, you will be requested at the start of the method to read the barcode of the first position in the list.
  - *None*: No barcode ID is assigned to the labware.
9. Click on *OK* to confirm the settings.  
The labware is positioned in the location.

10. Proceed in the same way to equip the other locations on the worktable.

The labware on the worktable is also displayed in the *Placement* list on the left-hand side of the *Worktable* tab.

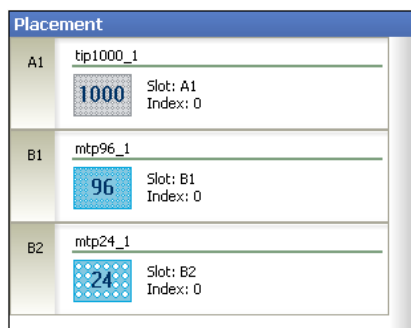

When positioning labware, please note the following restrictions:

- **all A locations:** no ReservoirRack.

To check whether a particular labware item can be positioned in a location, try dragging the labware over that location and observe the shape of the mouse pointer: the labware can be positioned only if the mouse pointer carries a "+" (plus) symbol.

### Stacking labware at a location

You can stack certain labware components at a location one above the other, e.g., selected plates or a height adapter and a plate.

In the locations you can stack a maximum of five predefined plates from Eppendorf. The maximum stacking height is 126 mm. The following plates can be stacked in a location:



For plate stacking, you must select the same setting for the *ID Label* option for all plates.

- EP\_pDNA\_96\_MTP
- EP\_TT\_PCR\_150
- EP\_TT\_PCR\_40
- EP\_DWP\_1200
- EP\_pDNA\_96\_DWP

To stack labware at a location, the specifications (geometry, name, bottom tolerance etc.) of the plates must be the same.



Additional labware suitable for stacking is available for download in the VIP section at [www.epMotion.com](http://www.epMotion.com). To download and import this labware, carry out a labware update.

Dispensing operations are not possible from a plate stack.

The optical sensor can perform location detection. Liquid detection is not possible.



When stacking plates, ensure that the filling level is adapted. The working volume should not be exceeded.

When stacking labware, always proceed in just the same way as when normally positioning individual labware components (see *Positioning labware on the worktable on p. 59*).

To stack labware at a location, proceed as follows.

1. Select and position the labware which is to be located in the **bottom** location (e.g., a height adapter).
2. Select and position the labware which is to be located at the same **top** location (e.g., a plate). Proceed in just the same way as when positioning the bottom labware component.

The two labware components are displayed in the location. The number of stacked items is displayed in brackets next to the location name.



The stacked labware components are also displayed in the *Placement* list on the left-hand side of the *Worktable* tab.

Placement	
A1	tip1000_1 1000 Slot: A1 Index: 0
A2	dwp96_1 96 Slot: A2 Index: 0
	Height_1 55 Slot: A2 Index: 1

### Editing labware properties on the worktable



You can edit the labware properties also for labware already placed onto the worktable.

To display and edit the properties of labware on the worktable, proceed as follows.

1. Double click on the labware on the worktable or right click on the labware in the *Placement* list and select *Properties* from the context menu.

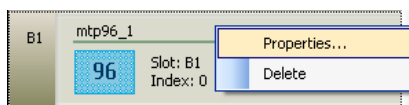

2. To edit the properties of stacked labware further down in the stack (e.g., a height adapter), right click on the labware in the *Placement* list and select *Properties* from the context menu. This labware can only be accessed via the *Placement* list.

A dialog window opens which allows you to change the settings for this labware.

### Remove labware from the Worktable

To remove labware from the worktable, proceed as follows.

1. Right-click on the labware on the worktable or right-click on the labware in the *Placement* list and select *Properties* from the context menu.
2. Or drag the labware from its location on the worktable to the waste position with the mouse, and drop it there.

The labware is removed from the worktable and also from the *Placement* list.

### 4.7.3 Procedure tab - defining a procedure

In the *Procedure* tab you can define the sequence of the commands to be executed when the method is run. It is recommended to first equip the worktable with the required labware before changing to the *Procedure* tab (see *Worktable tab - equip the worktable on p. 58*).

To go to the *Procedure* tab select the *Work* tab on the left-hand side of the program window and select the *Procedure* tab.

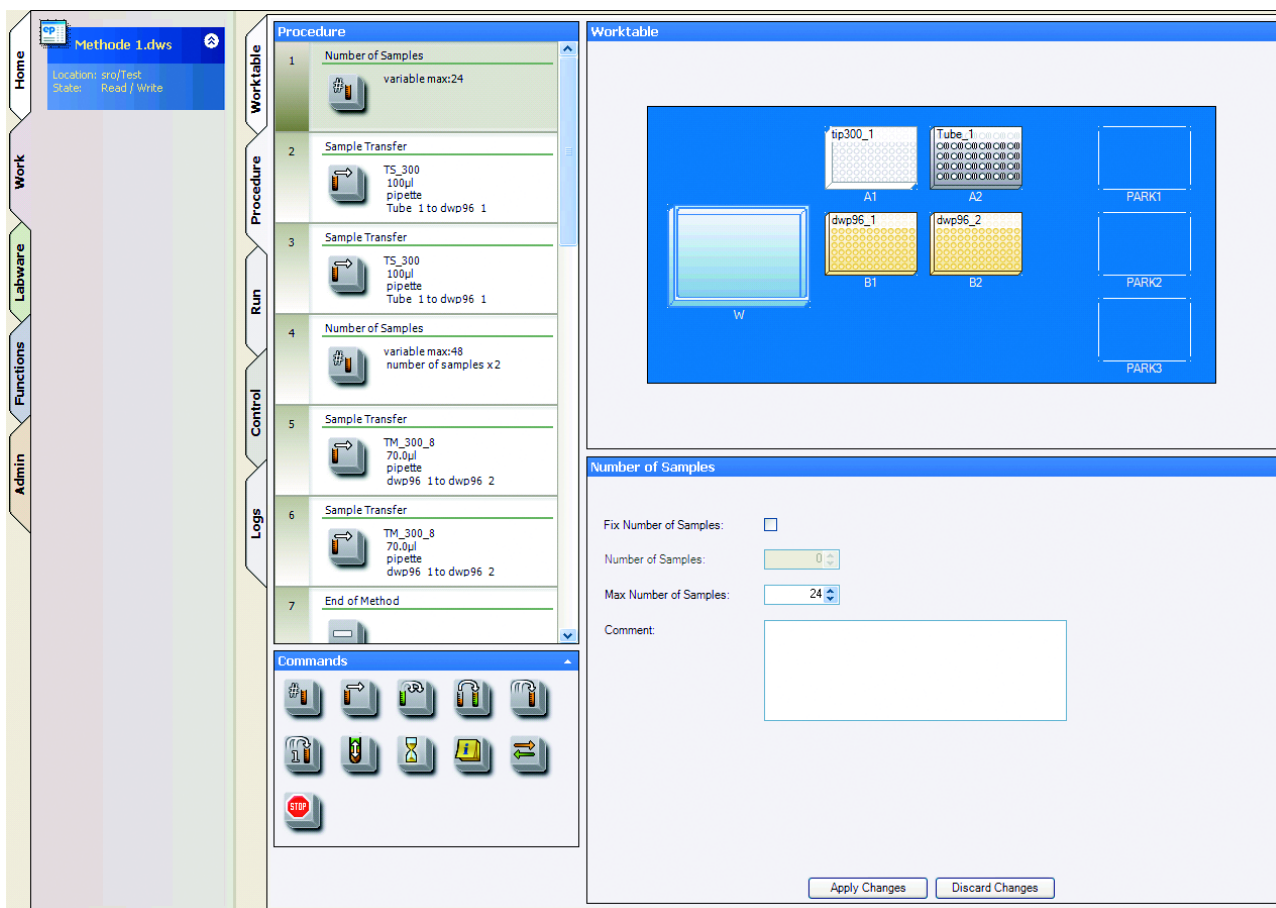

The *Procedure* tab is divided into 4 sections.

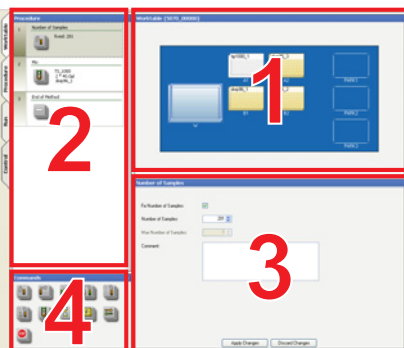

The *Worktable* (section 1) is displayed in the top right section of the *Procedure* tab. It shows the current worktable assignment for the active method. To edit the worktable you have to change to the *Worktable* tab (see *Worktable tab - equip the worktable on p. 58*).

The *Procedure* list (section 2) is displayed on the left-hand side of the *Procedure* tab. It shows the procedure as a list of commands, in the order in which they will be executed.

The *Parameter* section (section 3) is displayed in the bottom right section of the *Procedure* tab. It shows the parameters for the command which is currently selected in section 2. You can edit these parameters.

The *Commands* section (section 4) is displayed on the left-hand side under the *Procedure* list. It contains icons for all the commands you can use to define a procedure.

### Overview of the available commands

All available commands are displayed as icons in the Commands section under the *Procedure* list.



This section provides you with a brief overview of the commands. Details on all commands and their parameters are included in the reference list (see *Reference list of commands and parameters on p. 74*).



Barcode

Tracking a sample using a barcode ID is only possible with the *Sample Transfer*, *Pool*, *Pool One Destination* and *Dilute* commands. Use the *Reagent Transfer* command for ID-marked reagents. Reagent IDs are recorded in the *Input list* and *Log* but not in the result list. Basic information on barcode IDs can be found in the chapter "General information on working with ID tracking" (see p. 36).

The following commands are available for defining a procedure.



**Number of Samples:** Use the **Number of Samples** command to specify how many samples are to be processed in the subsequent steps of the procedure. The command can be used several times in a method to change the number of samples during the sequence of the procedure.



**Sample Transfer:** Use the **Sample Transfer** command to transfer samples from different locations of the source vessel labware to different locations of the destination vessel labware.



**Reagent Transfer:** Use the **Reagent Transfer** command to transfer samples from different locations of the source vessel labware to different locations of the destination vessel labware.



**Dilute:** The **Dilute** command is a modified **Sample Transfer** command making it easier to carry out diluting series. A defined volume is transported from one well to the next several times by means of pipetting.



**Pool:** The **Pool** command is used to transfer liquids from several source vessel locations to a single destination vessel location. For example, the contents of several source vessel labware wells can be pooled in a new destination vessel labware well.



**Pool:** The **Pool One Destination** command is used to transfer liquids from several source vessel locations to a single destination vessel location. This command is a simplified **Pool** command.



**Mix:** Use the **Mix** command to mix liquids at one location.



**Wait:** Use the **Wait** command to define a definite pause before the next step. The procedure continues automatically after the specified time has elapsed.



**Comment:** Use the **Comment** command to enter a comment line to be displayed at a specific location in the Procedure.



**Exchange:** The **Exchange** command is used to move labware to the location in the current method.



**User Intervention:** Use the **User Intervention** command to insert steps into your method which the user has to execute manually. The procedure only continues after the operator has confirmed the display message.

### Adding a command to the program

To add a command to the program, proceed as follows.

1. To **insert** a command anywhere in the program (either in the procedure or at the end) click on the Command icon in the *Command* section in the *Procedure* tab, e.g., on the *Sample Transfer* icon, drag the command to the top and drop it in the desired procedure location.



2. To **append** a command to the end of the procedure, double-click on the command icon in the *Command* section in the *Procedure* tab, e.g., on the *Sample Transfer* icon.

The command is added to the procedure.

The command parameters are displayed in the *Parameter* section of the *Procedure* tab.

3. Click on the *Parameters*, *Options*, *Mix* and *Liquid Type* tabs in the *Parameter* section to edit the command parameters as required by your method (see *Editing the parameters and options of a command on p. 67*).

The example shows the **Sample Transfer** command. Other commands can have different options in the *Parameter* section in the *Procedure* tab. Details on all commands and their parameters are included in the reference list (see *Reference list of commands and parameters on p. 74*).

4. Complete the procedure by adding other commands in the same way.

In addition to adding commands in the ways described above, you can also move a command up or down within the procedure (see p. 65), copy a command including its parameters and options (see p. 66), or delete a command from the procedure (see p. 67).

### Moving a command up or down in the procedure

To move a command to a different position in the procedure, proceed as follows.

1. In the *Procedure* list of the *Procedure* tab click on the command you want to move, drag it up or down with the mouse and drop it at the new location.

The command is moved to the new location.

### Duplicating a command

To duplicate a command, including its parameters and options, and insert the duplicate into the procedure, proceed as follows.

1. In the *Procedure* list of the *Procedure* tab select the original command and make sure that the parameters and options have been defined as necessary.
2. Click on the *Copy* icon, or right-click on the command and select *Copy* from the context menu.

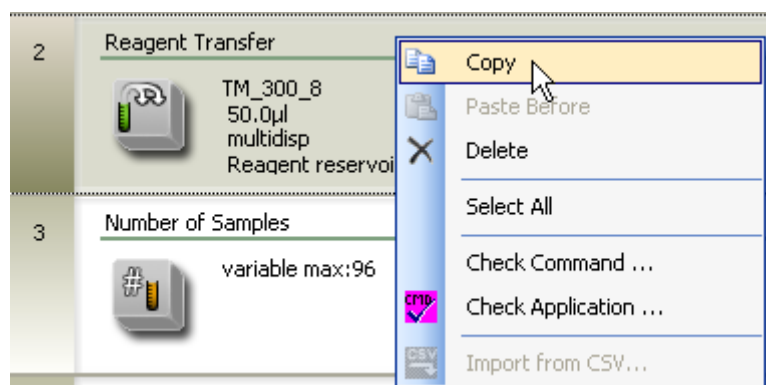

3. Select the command **below** the position in which you want to insert the duplicate, right-click and select *Paste before* from the context menu.

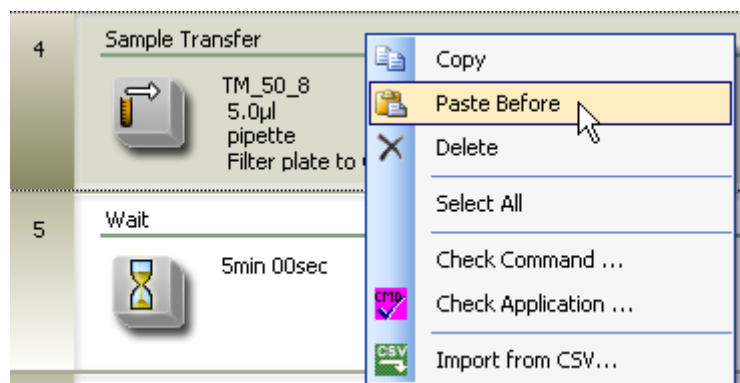

The command is duplicated and the duplicate is inserted at the chosen position.

You can now edit the parameters of the original command and the duplicate independently of each other.

### Removing commands from the procedure

To remove one or several commands from the procedure, proceed as follows.

1. In the *Procedure* list of the *Procedure* tab select the command you want to remove.
2. To select a sequence of commands, click on the first command in the sequence, then press the **Shift** key on the keyboard and click on the last command in the sequence.
3. Press the **Del** key on the keyboard, or right-click on the command or sequence of commands and select *Delete* from the context menu.

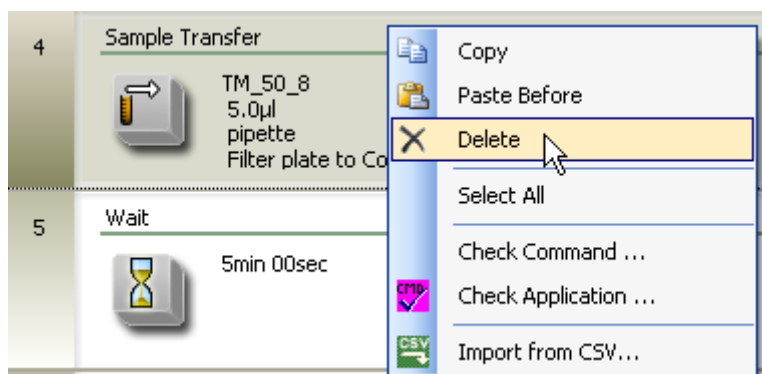

A warning message appears.

4. To delete, click on *OK*.  
The command or sequence of commands is removed from the procedure.

### Editing the parameters and options of a command

Each command has its own set of parameters, which you can edit at any time while you are creating or editing a procedure.

To edit the parameters and options for a command, proceed as follows.

1. In the *Procedure* list of the *Procedure* tab select the command you want to edit, e.g., a **Sample Transfer** command.

The command parameters are displayed in the *Parameter* section.

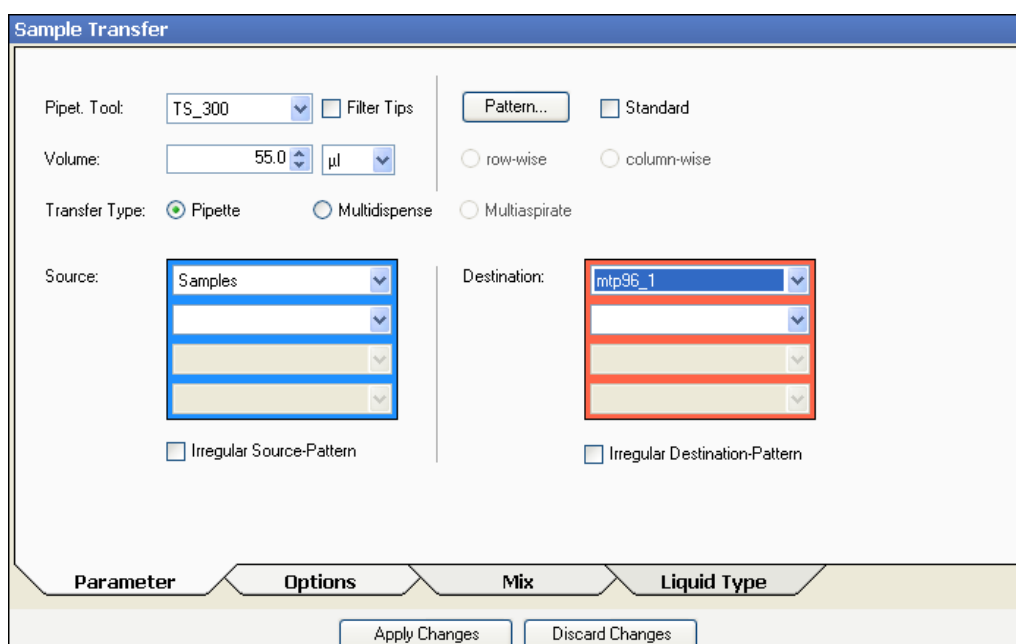

2. Select a dispensing tool from the *Pipet. Tool* list. If you are using filter tips, activate the *Filter Tips* option.
3. First set the volume to be dispensed (*Volume*) and select the *Transfer Type* (*Pipette* or *Multidispense*).
4. Select the source vessel (*Source*) and the destination vessel (*Destination*) for the command (see *Define the source vessel (Source) and destination vessel (Destination) for a transfer on p. 68*).
5. Specify the *Pattern* for the command (see *Editing the pattern for a Transfer command on p. 70*).
6. To specify further options for the command (e.g., *Liquid Type*, settings for mixing and changing tips), click on the *Options*, *Mix* and *Liquid Type* tabs in the *Parameter* section to edit the parameters according to the requirements of your method.
7. To discard the changes, click immediately on *Discard Changes* under the *Parameter* section **before** selecting a different command in the *Procedure* list.
8. To accept the changes, click on *Apply Changes* under the *Parameter* section or select a different command in the *Procedure* list.

The example shows the **Sample Transfer** command. Other commands may have different options in the *Parameter* section in the *Procedure* tab. For a detailed description of the available parameters and options for each command, see the reference list of commands (see *Reference list of commands and parameters on p. 74*).

#### Define the source vessel (Source) and destination vessel (Destination) for a transfer

You can define up to 4 source vessel and destination vessel locations for each **Transfer** command. To use labware as source or destination for a **Transfer** command the labware must first have been positioned on the worktable (see *Positioning labware on the worktable on p. 59*).

Within one **Transfer** command you can define up to 4 labware locations for source vessels and up to 4 locations for destination vessels. The second and all further labware locations must be compatible with the first labware selected.

There are 2 options for defining source and destination vessels for a **Transfer** command:

- You can select source and destination vessel labware from a list with labware objects positioned on the worktable (see p. 68).
- Immediately after adding a command to the procedure you can define a source and destination vessel via mouse click (see p. 69).

#### Selecting source vessel and destination vessel from a list

You can select up to 4 source vessel and destination vessel locations by selecting labware from a list of labware items positioned on the worktable. To do so, proceed as follows.

1. In the *Procedure* list of the *Procedure* tab select the command you want to edit, e.g., a **Sample Transfer** command.
2. In the *Parameter* section select the first source vessel labware from the list.

The list for the next location becomes active automatically. The second list shows only labware on the worktable which is compatible with the first selected labware location.

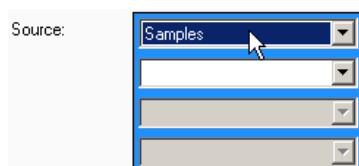

3. Specify further source vessel locations in the same way, if required.

4. Select the destination vessel labware in the same manner.



The source vessel and destination vessel locations for this command are active immediately.

### Clicking on source and destination with the mouse

You can define up to 4 source vessel and destination vessel locations by clicking with the mouse (only possible **immediately** after you have added the command to the procedure). To do so, proceed as follows.

1. Add a command to the procedure, e.g., a **Sample Transfer** command (see *Adding a command to the program on p. 65*).
2. Immediately after adding the command, move the mouse over the worktable.  
The mouse pointer changes into a dispensing tool symbol.
3. Click on the first source vessel labware on the worktable.

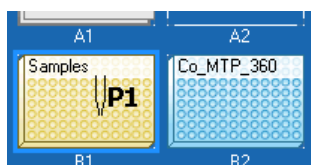

The selected source vessel labware is highlighted in blue and the *Source* list in the *Parameter* section displays the name of the labware at the top.

4. If required, select further source vessel locations by clicking with the mouse (up to 4 locations).

They are also highlighted in blue and displayed as source vessel locations in the *Parameter* section.

5. To define the destination vessel labware, press the *Ctrl* key on the keyboard and keep it pressed while clicking on the first destination vessel labware on the worktable.

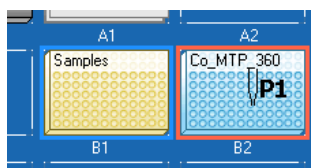

The selected destination vessel labware is highlighted in red and the *Destination* list in the *Parameter* section displays the name of the labware at the top.

6. If required, select further destination locations by holding the *Ctrl* key and clicking with the mouse (up to 4 locations).

They are also highlighted in red and displayed as destination vessel locations in the *Parameter* section.

The source and destination locations for this command are active immediately. You can edit them later by selecting different locations from the lists in the *Parameter* section (see *Selecting source vessel and destination vessel from a list on p. 68*).

## Editing the pattern for a Transfer command

The following pattern types are available for **Transfer** commands:

- **Standard pattern** (only for **Sample Transfer** commands): A simple standard pattern which can be based on rows or columns.
- **Regular pattern with automatic pattern detection** (for all commands except when using ReservoirRack): a standard pattern which is not strictly based on rows or columns, e.g., for pipetting a sample from the first column of a source vessel plate 1:1 to the second column of a destination vessel plate. To define this pattern, you need to specify only the first few positions. The pattern is then recognized and completed automatically.
- **Irregular pattern** (for some commands (see *Reference list of commands and parameters on p. 74*)): irregular pattern for a plate or module rack in which the source vessel and destination vessel locations can be defined freely. Automatic pattern detection is not possible, all locations must be specified manually (see *Creating an irregular pattern for a plate or a rack on p. 72*).

To edit the pattern for a **Transfer** command proceed as follows.

1. In the *Procedure* list of the *Procedure* tab select the command you want to edit (e.g., a **Sample Transfer** command) and define the source and destination vessel labware (see *Define the source vessel (Source) and destination vessel (Destination) for a transfer on p. 68*).
2. If the **Sample Transfer** command requires a standard pattern either by rows or columns, place a tick in the *Standard* checkbox and select the *row-wise* or *column-wise* option.

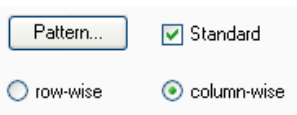

3. To define a regular pattern that is not row-wise or column-wise, click on the *Pattern* button. The Pattern window opens.

The source and destination vessel labware is displayed. The source vessel labware is displayed on the left-hand side with a blue frame. The destination vessel labware is displayed on the right-hand side with a red frame.

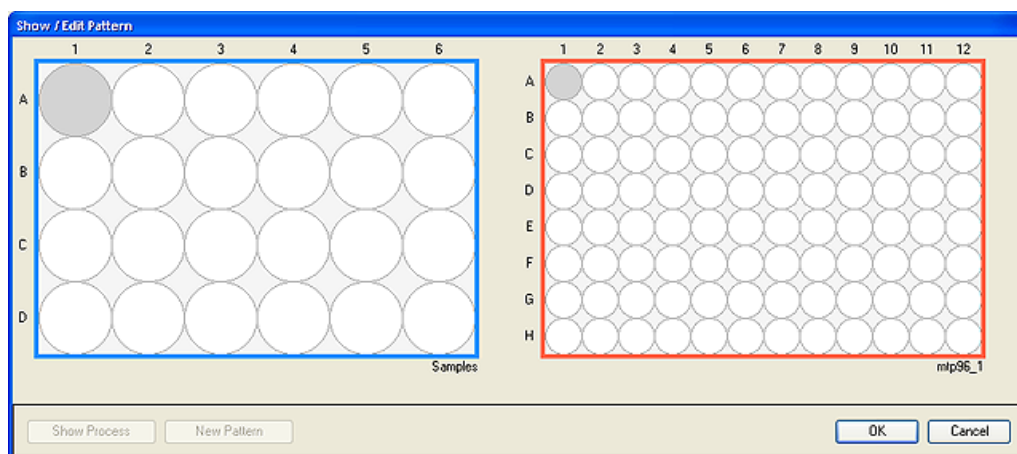

4. If there is a previous pattern that you do not want to use, click on the *New Pattern* button to remove it.

- In the source vessel labware click on the first location from which liquid is to be aspirated (e.g., location 1A).

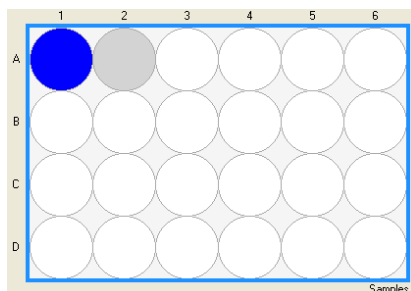

- In the destination vessel labware click on the location (or locations) to which the first liquid volume is to be transferred (e.g., location 2A).

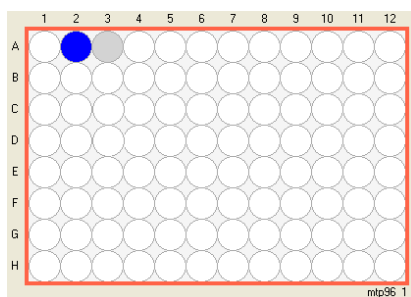

- In the source vessel labware click on the second location from which liquid is to be aspirated (e.g., location 1B).

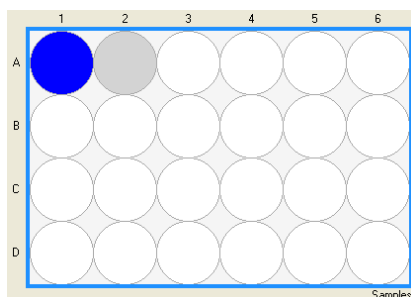

- In the destination vessel labware click on the location (or locations) to which the second liquid volume is to be transferred (e.g., location 2B).

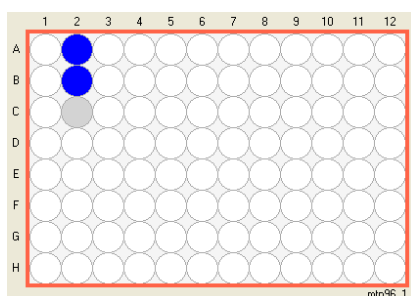

epBlue will attempt to recognize the intended pattern and will highlight the next position in gray.

- If the recognized pattern matches your requirements, click on *OK* to confirm and close the Pattern window. The pattern will be completed automatically up to the defined number of samples.

10. If you wish to discard the recognized pattern, click on *New Pattern* and start again.

11. To check a defined pattern, click on *Show Process* in the pattern window.

The pattern sequence is displayed and the corresponding source and destination locations are displayed in the same color.

For a description of all available commands and their parameters, see the reference list of commands (see *Reference list of commands and parameters on p. 74*).

Alternatively, you can create an irregular pattern for a plate or ReservoirRack (see *Creating an irregular pattern for a plate or a rack on p. 72*).

### Creating an irregular pattern for a plate or a rack

An **irregular pattern** for a plate or ReservoirRack is a pattern in which the source and destination vessel locations can be defined freely. Automatic pattern detection is not possible, all positions must be specified manually. Alternatively, you can define a **standard pattern** (row-wise or column-wise) or a **regular pattern with automatic pattern detection** (see *Editing the pattern for a Transfer command on p. 70*).

To create an irregular pattern for a plate, rack or ReservoirRack, proceed as follows.

1. In the *Procedure* list of the *Procedure* tab select the command you want to edit (e.g., a **Sample Transfer** command) and define the source and destination vessel labware (see *Define the source vessel (Source) and destination vessel (Destination) for a transfer on p. 68*).
2. In the *Parameter* section in the *Irregular Pattern* checkbox under the list with the source and/or destination vessel labware place a tick as required.

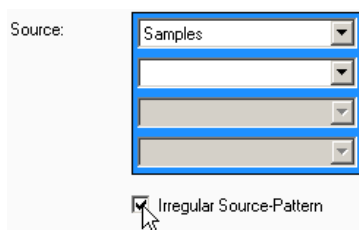

3. Click on the *Pattern* button.

The Pattern window opens.

The source and destination vessel labware is displayed. The source vessel labware is displayed on the left-hand side highlighted in blue. The destination vessel labware is displayed on the left-hand side highlighted in red.

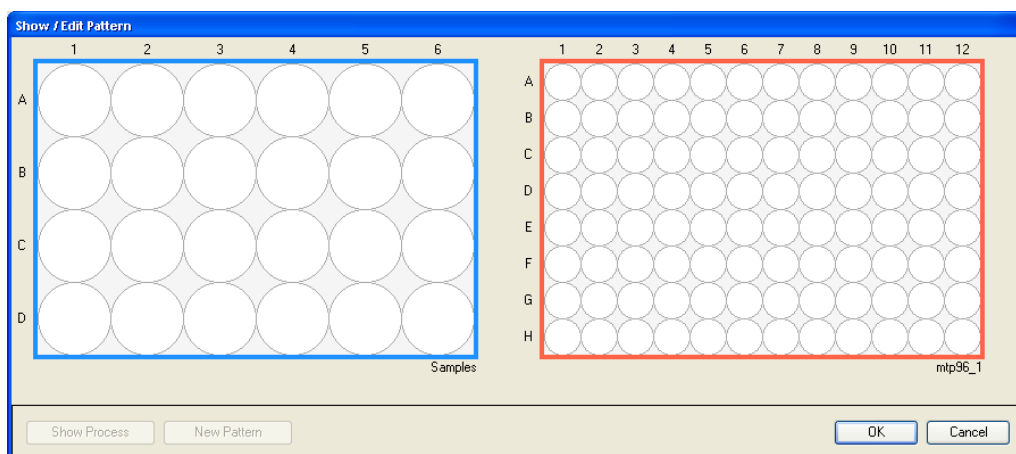

- In the source vessel labware click on the first location from which liquid is to be aspirated.

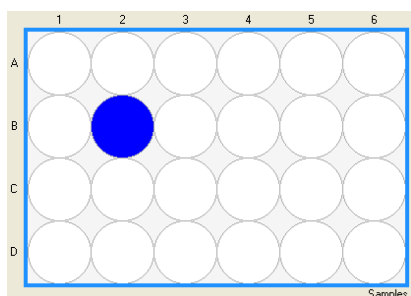

- In the destination vessel labware click on the location to which the first liquid volume is to be transferred.

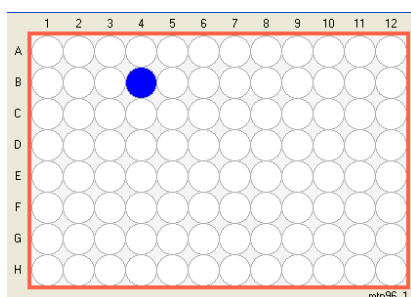

- Select all locations of the intended pattern in the same way, alternating between source vessel and destination vessel labware.
- To confirm the pattern and close the Pattern window, click on *OK*.
- If you wish to discard the pattern, click on *New Pattern* and start again.
- To check a defined pattern, click on *Show Process* in the pattern window.  
The pattern sequence is displayed and the corresponding source and destination vessel locations are displayed in the same color.

For a description of all available commands and their parameters, see the reference list of commands (see *Reference list of commands and parameters on p. 74*).

### Checking the method or individual commands (parameter test)

The parameter test allows you to check whether all required parameters are set, either for the entire method or for individual commands or a sequence of commands.

- To check the parameter settings of the current method, click on the *Check Application* icon in the toolbar of the *Work* (see p. 54) tab or select *Edit - Check Application* from the main menu or right-click on a created command and select *Check Application* from the context menu.
- To check an individual command or a sequence of commands, right-click on the command and select *Check* from the context menu or select *Edit - Check Commands* from the main menu.

A message window opens to inform you if a parameter error was found. Correct the error and repeat the check until all errors have been corrected.

## Importing commands from a CSV file

When working with biological material (e.g., protein solutions, nucleic acid solutions), it may be necessary to transfer defined quantities of different samples from various parent solutions to a target container in order to adjust the concentration (thus creating standards). The quantities of sample material that must be transferred can be determined by physical measurements (e.g., by using spectroscopic methods, enzymatic analysis, or chemical methods), and the resulting quantities can then be listed in a table.

- ▶ To import a table in CSV file format, select *Edit - Import from CSV* from the menu.

For details, please refer to the appendix (see *Importing commands from a CSV file on p. 217*).

## 4.7.4 Reference list of commands and parameters

This reference list contains all available commands and their parameters and options. Further details and specialized information can be found in the appendix.

You can use these commands to define a procedure (see *Procedure tab - defining a procedure on p. 63*).

## General configurations for Transfer commands

The following general parameters and options are used for **Transfer** commands. Click on the *Parameters*, *Options*, *Mix* and *Liquid Type* tabs in the *Parameters* section to edit the command parameters as required by your method.



Some parameters may differ or may not be available for individual commands. In this case please find additional details in the section about the corresponding **Transfer** command: **Sample Transfer** (see p. 76), **Reagent Transfer** (see p. 76), **Dilute** (see p. 76), **Pool** (see p. 77) and **Pool One Destination** (see p. 77).

### Parameter

- *Pipet. Tool / Filter Tips*: select the dispensing tool you want to use from the list. If you are using filter tips, activate the Filter Tips option.
- *Volume*: enter the volume to be transferred in each step. The volume is aspirated or dispensed according to the transfer types specified below.
- *Transfer type*
  - *Pipette*: the volume set above is aspirated or dispensed in each step.
  - *Multidispense*: the volume set above is dispensed in each multidispense step.
  - *Multiaspirate*: the volume set above is aspirated in each multiaspirate step.
- *Source/Destination*: select the source vessel labware and destination vessel labware from the worktable allocation (see *Define the source vessel (Source) and destination vessel (Destination) for a transfer on p. 68*).
- *Pattern*: the pattern is used to specify aspiration and dispensing positions within this command.
  - Standard pattern: if the command requires a standard pattern that is either row-wise or column-wise, check the *Standard* checkbox and select the row-wise or column-wise option.
  - Regular pattern with automatic pattern detection: to define a regular pattern that is not row-wise or column-wise, click on the *Pattern* button and define the intended pattern (see *Editing the pattern for a Transfer command on p. 70*).
  - Irregular pattern: to create an irregular pattern for a plate or a ReservoirRack, check the *Irregular Pattern* checkbox below the list of source and/or destination vessel labware as required. Then click on the *Pattern* button and define the intended pattern (see *Creating an irregular pattern for a plate or a rack on p. 72*).

### Options

- *Aspirate from bottom*: select if the liquid is to be aspirated from the bottom of the well.
- *Elution from filter*: select if the liquid is to be aspirated from a PCR Cleanup filter plate.
- *Dispense from top*: select if the liquid is to be dispensed from the top edge of the well.
- *Change tips*: select one of the available options to specify when the tips are to be changed.

### Mix

- *Mix before aspirating / Mix after dispensing*: activate the relevant option if the liquid is to be mixed before aspiration or after dispensing. To mix the liquid, it will be aspirated into the tip and dispensed back into the same well.
- *No. of cycles*: set the required number of mixing cycles.
- *Speed*: set the mixing speed.
- *Volume*: set the volume that is to be aspirated and dispensed during the mixing process.
- *Fixed height*: activate this option if you wish to use fixed height positions for mixing, and set the height values for aspiration and dispensing. The height is measured between the tip and the bottom of the well.

This option should only be used with filling levels below the volume of the well. With greater filling volumes, liquid can be forced out of the tube or well!

### Liquid Type

- *Standard Liquid Type*: select the liquid type which most closely resembles the physical properties of the liquid you want to transfer.
- *Change Parameters*: to change the settings for the selected liquid type for this command, activate this option and set the values according to your requirements.  
To restore the default settings for the selected liquid type, click the *Set Default* button.

## Number of Samples

Use the **Number of Samples** command to specify how many samples are to be processed in the subsequent steps of the procedure. It applies to all commands until the next **Number of Samples** command in the procedure. The command can be used several times in a method to change the number of samples during the sequence of the procedure.

Dependent on the type and purpose of the following commands, the **Number of Samples** command has different effects:

- *Sample Transfer*: number of samples picked up by the source vessel plate.
- *Reagent Transfer*: number of wells of the destination vessel plate into which the reagent is dispensed.
- *Dilute*: number of samples to be diluted.
- *Pool* and **Pool One Destination**: Number of wells in the source vessel plate from which liquid is aspirated.
- *Mix*: number of wells in the plate in which the liquid is mixed.

### Parameter

- *Fix Number of Samples / (Max) Number of Samples*: to define a fixed number of samples for all runs of this method, activate the *Fix Number of Samples* option and enter the required number. The specified number of samples will then be used for all runs.  
To use a variable number of samples, deactivate the *Fix Number of Samples* option and enter the maximum number of samples. The exact number of samples for each individual run must then be entered by the operator when the method starts.
- *Comment*: enter a comment, if required. The comment will be displayed at the start of the method.

## Sample Transfer

Use the **Sample Transfer** command to transfer samples from different locations of the source vessel labware to different locations of the destination vessel labware. During the **Sample Transfer** each sample is transferred in accordance with a defined pattern from its original well in the source vessel plate to a defined well in the destination vessel plate.

This command requires the general parameters for **Transfer** commands (see *General configurations for Transfer commands on p. 74*). The following details are specific for this command.

### Parameter

- *Transfer type*
  - *Pipette*: the volume set above is aspirated or dispensed in each step.
  - *Multidispense*: the volume set above is dispensed in each multidispense step.
  - *Multiaspirate*: not available.

## Reagent Transfer

Use the **Reagent Transfer** command to transfer samples from a location in the source vessel labware to different locations in the destination vessel labware. During the reagent transfer, the reagent is taken from its tube or well in the source vessel labware and dispensed into various specified wells in the destination vessel plate, according to the defined pattern.

This command requires the general parameters for **Transfer** commands (see *General configurations for Transfer commands on p. 74*). The following details are specific for this command.

### Parameter

- *Transfer type*
  - *Pipette*: the volume set above is aspirated or dispensed in each step.
  - *Multidispense*: the volume set above is dispensed in each multidispense step.
  - *Multiaspirate*: not available.
- *Pattern*: the pattern is used to specify aspiration and dispensing positions within this command.
  - Standard pattern: not available.
  - Regular pattern with automatic pattern detection: to define a regular pattern that is not row-wise or column-wise, click on the *Pattern* button and define the intended pattern (see *Editing the pattern for a Transfer command on p. 70*).
  - Irregular pattern: to create an irregular pattern for a plate or a ReservoirRack, check the *Irregular Pattern* checkbox below the list of source and/or destination vessel labware as required. Then click on the *Pattern* button and define the intended pattern (see *Creating an irregular pattern for a plate or a rack on p. 72*).

## Dilute

The **Dilute** command is a modified **Sample Transfer** command making it easier to carry out diluting series. A defined volume is transported from one well to the next several times by means of pipetting.

This command requires the general parameters for **Transfer** commands (see *General configurations for Transfer commands on p. 74*). The following details are specific for this command.

### Parameter

- *Transfer type*
  - *Pipette*: the volume set above is aspirated or dispensed in each step.
  - *Multidispense*: not available.
  - *Multiaspirate*: not available.

- *Pattern*: the pattern is used to specify aspiration and dispensing positions within this command.
  - Standard pattern: not available.
  - Regular pattern with automatic pattern detection: to define a regular pattern that is not row-wise or column-wise, click on the *Pattern* button and define the intended pattern (see *Editing the pattern for a Transfer command on p. 70*).
  - Irregular pattern: Only available for the source vessel location. To create an irregular pattern for a source plate or a ReservoirRack, check the *Irregular Pattern* checkbox below the list of source and/or destination vessel labware. Then click on the *Pattern* button and define the intended pattern (see *Creating an irregular pattern for a plate or a rack on p. 72*).

#### Options

- *Aspirate from bottom*: select if the liquid is to be aspirated from the bottom of the well.
- *Elution from filter*: not applicable.
- *Dispense from top*: select if the liquid is to be dispensed from the top edge of the well.
- *Change tips*: select one of the available options to specify when the tips are to be changed.

### Pool

The **Pool** command is used to transfer liquids from several source vessel locations to a single destination vessel location. For example, the contents of several source vessel labware wells can be pooled in a new destination vessel labware well.

This command requires the general parameters for **Transfer** commands (see *General configurations for Transfer commands on p. 74*). The following details are specific for this command.

#### Parameter

- *Transfer type*
  - *Pipette*: the volume set above is aspirated or dispensed in each step.
  - *Multidispense*: not available.
  - *Multiaspirate*: the volume set above is aspirated in each multiaspirate step.
- *Pattern*: the pattern is used to specify aspiration and dispensing positions within this command.
  - Standard pattern: not available.
  - Regular pattern with automatic pattern detection: to define a regular pattern that is not row-wise or column-wise, click on the *Pattern* button and define the intended pattern (see *Editing the pattern for a Transfer command on p. 70*).
  - Irregular pattern: not available.

#### Options

- *Aspirate from bottom*: select if the liquid is to be aspirated from the bottom of the well.
- *Elution from filter*: not applicable.
- *Dispense from top*: select if the liquid is to be dispensed from the top edge of the well.
- *Change tips*: select one of the available options to specify when the tips are to be changed.

### Pool One destination

The **Pool One Destination** command is used to transfer liquid from several source vessel locations to a single destination vessel location. This command is a simplified **Pool** command.(see *Pool on p. 77*)

This command requires the general parameters for **Transfer** commands (see *General configurations for Transfer commands on p. 74*). The following details are specific for this command.

**Parameter**

- *Transfer type*
  - *Pipette*: the volume set above is aspirated or dispensed in each step.
  - *Multidispense*: not available.
  - *Multiaspirate*: the volume set above is aspirated in each multiaspirate step.
- *Pattern*: the pattern is used to specify aspiration and dispensing positions within this command.
  - Standard pattern: not available.
  - Regular pattern with automatic pattern detection: to define a regular pattern that is not row-wise or column-wise, click on the *Pattern* button and define the intended pattern (see *Editing the pattern for a Transfer command on p. 70*).
  - Irregular pattern: Only available for the source vessel location. To create an irregular pattern for a source plate or a ReservoirRack, check the *Irregular Pattern* checkbox below the list of source and/or destination vessel labware. Then click on the *Pattern* button and define the intended pattern (see *Creating an irregular pattern for a plate or a rack on p. 72*).

**Options**

- *Aspirate from bottom*: select if the liquid is to be aspirated from the bottom of the well.
- *Elution from filter*: not applicable.
- *Dispense from top*: select if the liquid is to be dispensed from the top edge of the well.
- *Change tips*: select one of the available options to specify when the tips are to be changed.

**Mix**

Use the **Mix** command to mix liquids at one location. To mix the liquid, it will be aspirated into the tip and dispensed back into the same well.

**Parameter**

- *No. of cycles*: set the required number of mixing cycles.
- *Speed*: set the mixing speed.
- *Tool / Filter Tips*: select from the list the dispensing tool you want to use. If you are using filter tips, activate the *Filter Tips* option.
- *Mixing Volume*: set the volume that is to be aspirated and dispensed during the mixing process.
- *Fixed height*: activate this option if you wish to use fixed height positions for mixing, and set the height values for aspiration and dispensing. The height is measured between the tip and the bottom of the well.  
This option should only be used with filling levels below the volume of the well. With greater filling volumes, liquid can be forced out of the reaction vessel or well!
- *Racks*: select the labware from the worktable assignment.
- *Pattern*: the pattern is used to specify mixing positions within this command.
  - Regular pattern with automatic pattern detection: click on the *Pattern* button and define the intended pattern.
  - Irregular pattern: To create an irregular pattern place a tick in the *Irregular Pattern* checkbox under the *Racks* list. Then click on the *Pattern* button and define the intended pattern.

**Options**

- *Liquid Type*: select the *Liquid Type* which most closely resembles the physical properties of the liquid you want to mix.
- *Change tips*: select one of the available options to specify when the tips are to be changed.

### Exchange (epMotion 5070)

The **Exchange** command is used to carry out a manual labware exchange between 2 worktable locations. When the method runs on the epMotion 5070, the run stops at the Exchange command and the operator is requested to change the labware manually.

#### Parameter

- *exchange Labware*: select the first labware to be changed.
- *with Labware*: select the second labware.

### Wait

The **Wait** command defined a definite pause before the next step. The procedure continues automatically after the specified time has elapsed.

#### Parameter

- *Wait Time*: set the duration of the pause.
- *Wait for Temperature / Location*: activate this option if the epMotion 5070 should wait until the target temperature at a location has been reached, and select the location from the list.

### Comment

Use the **Comment** command to enter a comment line to be displayed at a specific location in the Procedure.

- *Comment*: enter the text for the comment.

### User Intervention

Use the **User Intervention** command to insert steps into your method which the user has to execute manually. The procedure only continues after the operator has confirmed the display message.

- *Comment*: enter an informative comment to tell the operator what task he or she needs to carry out.
- *Alarm*: activate this option for an alerting signal when this step in the procedure is reached.

#### 4.7.5 The Run tab

With the *Run* tab you can start a method on one or several devices available in your system.

To go to the *Run* tab select the *Work* tab on the left-hand side of the program window and select the *Run* tab.

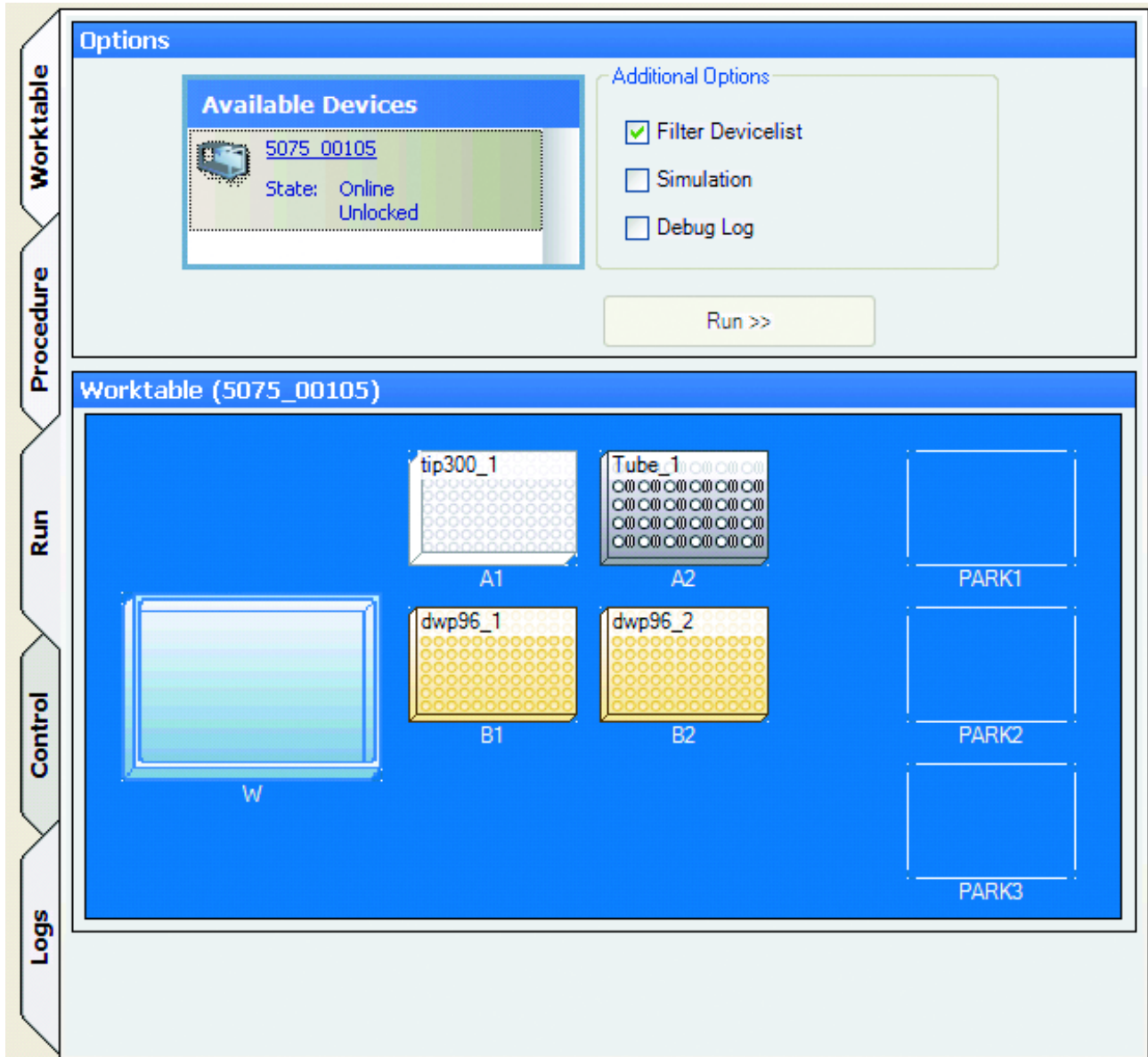

The *Run* tab is divided into 2 sections.

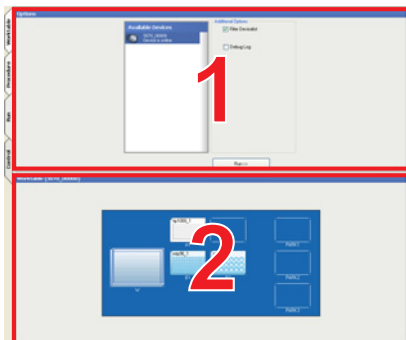

The **Options** section (section 1) is displayed in the top part of the *Run* tab. It guides you through the starting process step by step and allows you to enter additional parameters and select the required options for the run.

The **Worktable** (section 2) is displayed in the bottom part of the *Run* tab. It shows the worktable assignment for the active method and allows you to check the labware for the method. You cannot edit the worktable here; To do so you need to change to the *Worktable* tab (see *Worktable tab - equip the worktable on p. 58*).

To start a method, proceed as follows.

1. Open the method (see *Opening an application on p. 42*).
2. Change to the *Run* tab or, while the *Worktable* or *Procedure* tabs are active, click on the *Start Method* icon.

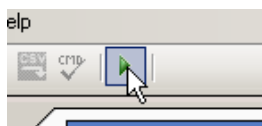

The *Options* section in the *Run* tab displays a list of devices in your system. To display only devices which are currently available and suitable for the selected method, activate the *Filter Devicelist* option.

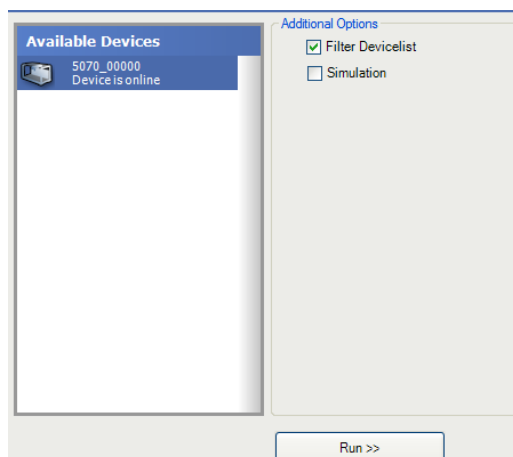

3. Select the device you want to use and click on *Run*.

If the number of samples is defined as variable for any step in the procedure, a window opens in which the actual number of samples for the current run must be entered manually. The number of samples request does not appear in methods with a fixed number of samples.

4. Enter the number of samples and click on *OK*. If required, enter the number of samples for further commands in the same way.

5. Check the equipping of the worktable of the device and make sure that it matches the worktable assignment defined for the method (as displayed in the *Worktable* section of the *Run* tab).



If barcode tracking is activated, in the labware settings window you can select between the settings *manual scan* and *entry list*.

6. To edit labware-specific settings for optical sensor and volumes, double-click on the labware in the *Worktable* section.  
The *Labware Settings* window opens.

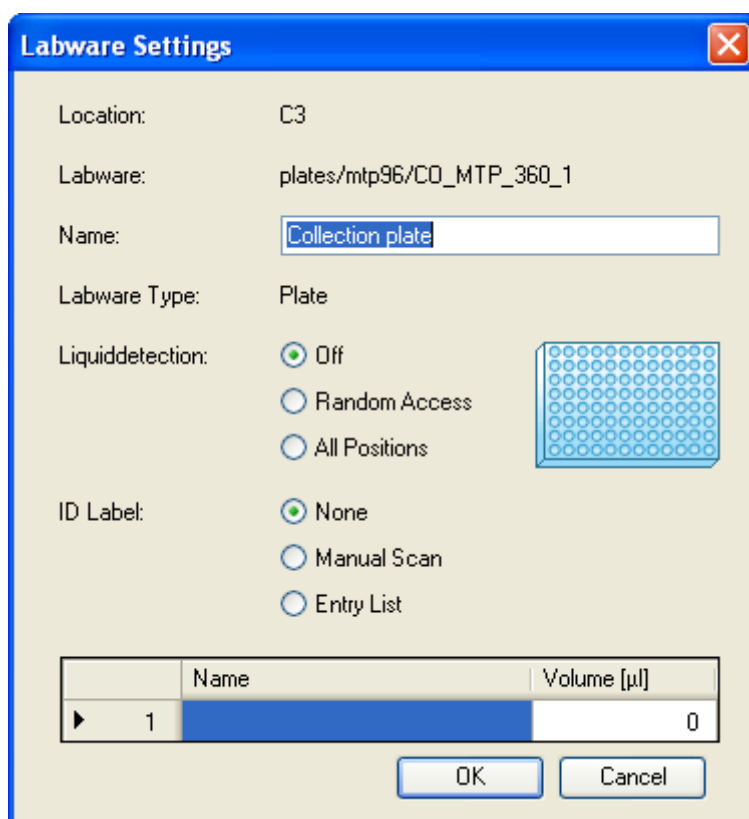

7. Change the settings as required, and click on *OK*. Edit the settings for other labware in the same way, if required.



The *Barcode Reader Settings* checkbox is only active if ID tracking has been switched on in the method to be started (see p. 58).

8. If you want to deactivate barcode tracking for this run, deactivate the *Barcode Reader Settings* checkbox.

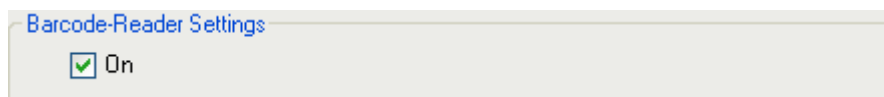

9. Under *Level Sensor Settings* in the *Options* section define the level sensor settings for this run.

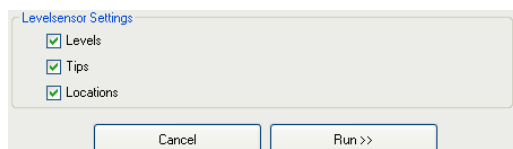

The following options are available:

- *Levels*: check the levels according to the settings defined for the individual labware items.
- *Tips*: check the type and quantity of tips in the tip rack.
- *Locations*: check that the labware is positioned correctly on the worktable, as specified in the method.

The options you select here only apply to this particular run. To define the general level sensor settings use the function **Optical Sensor** in *Functions* tab (see *Optical sensor on p. 102*).

10. Only for an epMotion with epBlue ID and barcode reader: click on *Run* or *Next*.

If ID tracking has been activated in the method, you are prompted to enter the barcodes or IDs starting with the destination labware. The corresponding labware is highlighted in the worktable view by a red border.

- **Scan barcodes (manual scan)**: For racks the individual location to which the barcode is to be allocated is marked in red.
  - Name the list that is created during the run for this labware as required under *List name*.
  - Scan the appropriate barcode with the barcode reader or enter the ID manually into the input field after activating the checkbox next to *Manual Enter*.
  - When entering the barcode manually, confirm your input with *OK*. The barcode is entered on the right in the *Read Barcodes* list.
  - Click on the *Next* button to enter the barcodes for the next labware.
  - If 2 barcode IDs are to be issued for a reagent, 2 input fields appear for one ID each (see p. 105). If you do not require the second ID use *Use only one ID*.
  - The method starts when all barcode IDs have been assigned and no further entries are requested.
- **Entry lists**: For labware with activated *Entry list* proceed as follows:
  - The *Select entry list* window opens with all entry lists. At this point you also have the option of importing further entry lists.
  - Select the suitable list and press *Accept*. The name of the list appears in a text field under the displayed labware.
  - Scan the barcode for the marked position to enable the program to compare it with the entry list.  
If no other entries are required, the method will start if there is a match.

If the scanned barcode ID does not match the entry list, an error message will appear and the *Select entry list* windows is displayed again. Check whether the scanned code or the entry list is correct.

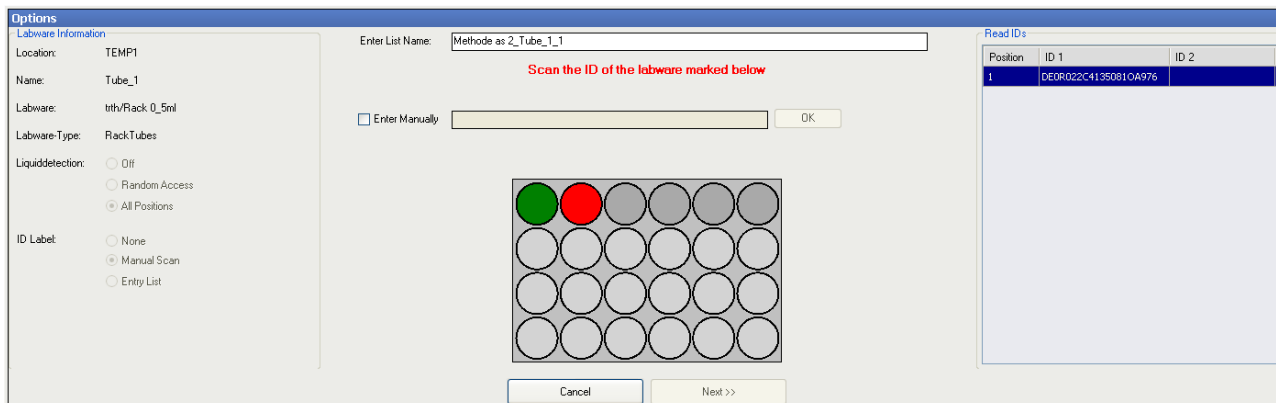

11. If liquid detection is switched off for the method or for individual labware components, the next steps display the labware information for each component, where the volume settings must be entered manually.

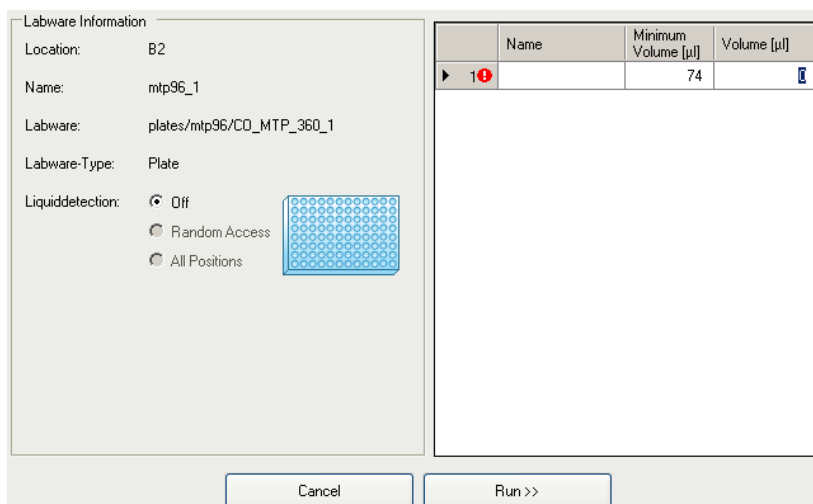

12. Enter the current volume and click on *Run*. If required, enter the volumes for other labware in the same way.

The method starts and the display changes to the *Control* tab(see *The Control tab* on p. 87).

## Simulation

Before you start your method, you have the ability to simulate the process.

To simulate a method, proceed as follows.

1. Open the method (see *Opening an application* on p. 42).
2. Change to the *Run* tab or, while the *Worktable* or *Procedure* tabs are active, click on the *Start Method* icon.

The *Options* section in the *Run* tab displays a list of devices in your system. To display only devices which are currently available and suitable for the selected method, activate the *Filter Devicelist* option.

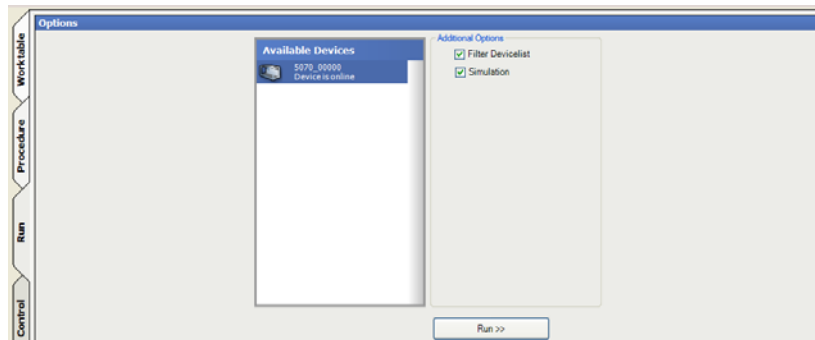

3. Select the device you want to use, click on *Simulation* and click on *Run*.  
If the number of samples is defined as variable for any step in the procedure, a window opens in which the actual number of samples for the current simulation of the method must be entered manually. The number of samples request does not appear in methods with a fixed number of samples.
4. Enter the number of samples and click on *OK*. If required, enter the number of samples for further commands in the same way.
5. Specify the level sensor settings for the simulation. Click on *Apply* when you change the settings or click on *Close* when you don't change the settings.  
The simulation starts in the *Simulation* tab.

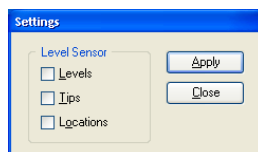

Only one simulation can start per client. To start a new simulation you have to close the last simulation first. To exit epBlue the simulation must be close.

### Controlling the simulation

If you start a simulation, the *Simulation* tab opens.

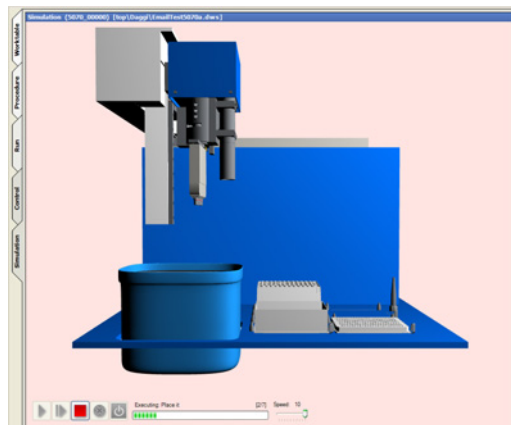

The Control icons allow you to control the simulation. The following options are available.



You can vary the speed of the simulation from real time (Value 1) to ten fold faster by moving the speed needle with the mouse.



**Start:** to continue the simulation. The simulation will resume until the end, or until you stop it again



**Steps:** to carry out the simulation step by step. The simulation will perform the next step or action, and will then stop again.



**Stop:** to interrupt the simulation. The simulation will stop at the current step or action and wait for further instructions. The other Control icons become active.



**Abort:** to abort the simulation.



**Exit:** to exit the simulation. The *Simulation* tab is closed. Now you can start another simulation or exit epBlue.

## Debug log



The debug log can only be recorded by the administrator and is required only if the Eppendorf Service team needs more information in the event of any faults occurring.

As administrator, you also have the option at the start of a method of recording a debug log for this run. The debug log records detailed information about the run in question.

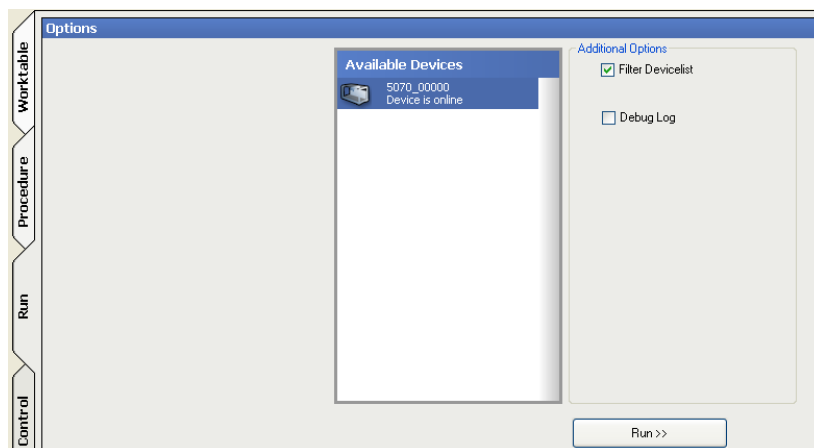

1. Before starting the method, click on the *Debug Log* checkbox. The checkbox then contains a tick.
2. Then start the method as usual. Recording the debug log can cause the run to proceed more slowly.
3. The debug log can be viewed and printed out from the *Logs* tab (see *The Logs tab on p. 89*).

#### 4.7.6 The Control tab

In the *Control* tab you can monitor and control the devices on which your methods are currently running.

epBlue automatically changes to the *Control* tab if you have started a method via the *Run* tab (see *The Run tab on p. 80*).

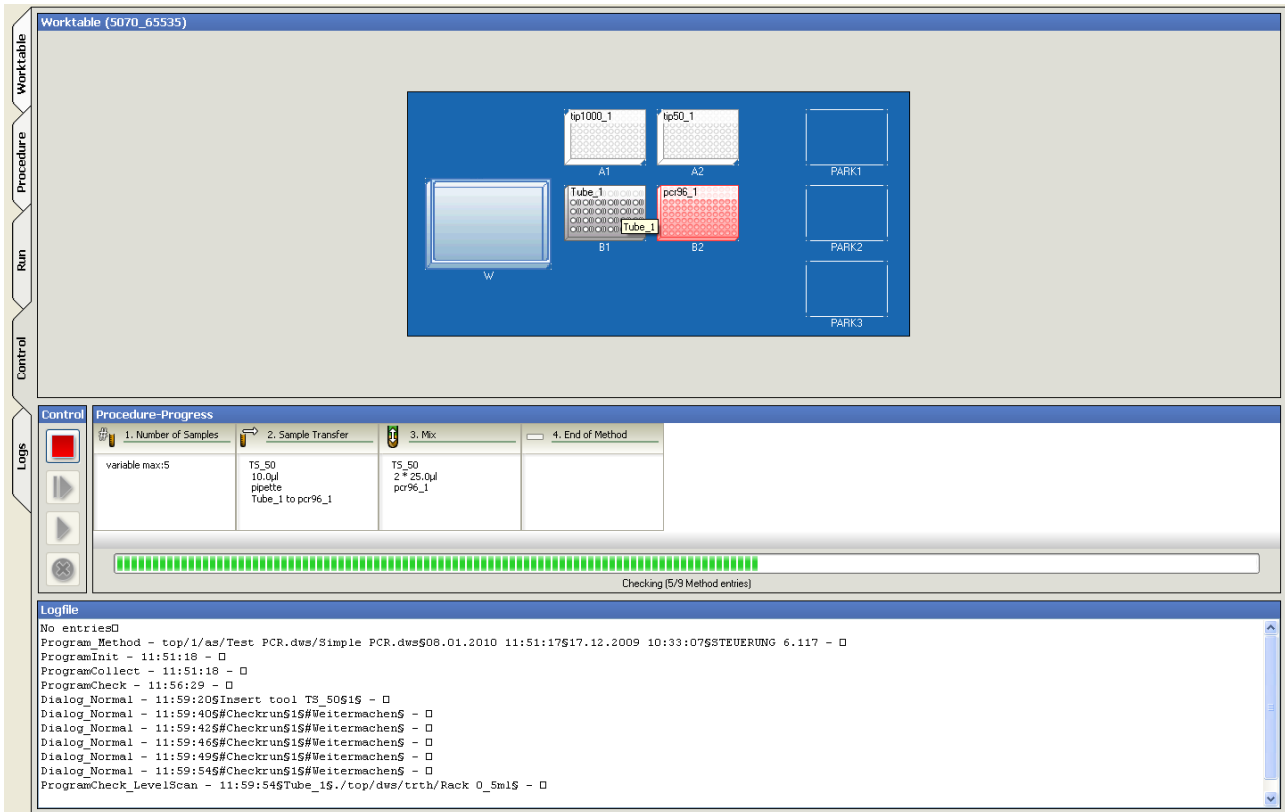

The *Control* tab is divided into 3 sections.

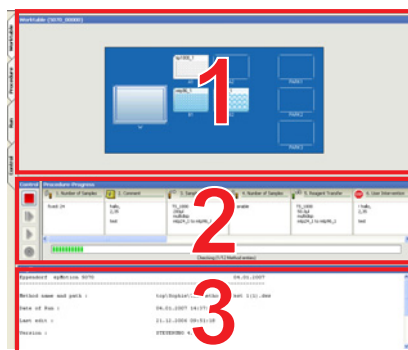

The *Worktable* section (section 1) is displayed in the top part of the *Control* tab. While the method is running, it shows the status of the worktable at the current step in the procedure.

The *Procedure Progress* section (section 2) is displayed in the center of the *Control* tab. It highlights the current step in the procedure and displays some information on the command that is being carried out. The **Control icons** on the left-hand side allow you to pause, to carry out the method step by step, or to abort the run.

The *Logfile* section (section 3) displays the log which records every step in the procedure and provides detailed information on the current status of the run.

## Controlling the run

Whilst the method is running the current command is highlighted in the *Procedure Progress* section.

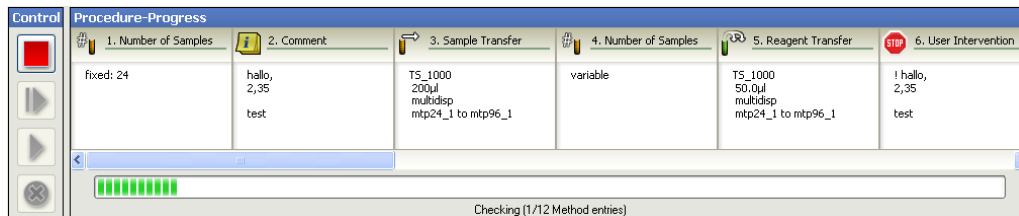

The Control icons allow you to control the run. The following options are available.



**Stop:** to stop the run. The device will stop at the current step or action and wait for further instructions. The other Control icons become active.



**Steps:** to carry out the method step by step. The device will perform the next step or action in the method, and will then stop again.



**Start:** to continue the run. The device will resume the run until the end, or until you stop it again.



**Abort:** to abort the run. The device will abort the run and return to its initial state.

## Reading logs

A log is generated automatically when a method is started. The log precisely records every step of the process.

You can view and print the logs and the method description (see *Printing applications and logs on p. 56*).

#### 4.7.7 The Logs tab

The *Logs* tab provides an overview of all logs that have run for this application.



**NOTICE!**

#### Data loss due to missing back-ups

The system does not automatically back up the logs.

- ▶ Save the logs using the **Backup** function.

Application name																																																
<b>Application :</b>	Simple PCR.dws - Rev. 1	Created	User	Result	Device																																											
	as - 17.12.2009 10:24:31	17.12.2009 10:33:09	as	Program Ended because o...	5070_65535																																											
	as - 17.12.2009 10:33:07	17.12.2009 10:39:05	as	Program Aborted by user	5070_65535																																											
<b>Last modified:</b>																																																
<b>Log file :</b>																																																
<b>Created :</b>	17.12.2009 10:39:05																																															
<b>User :</b>	as																																															
<b>Result :</b>	Program Aborted by user																																															
<b>Device :</b>	5070_65535																																															
<b>Device firmware:</b>	STEUERUNG 6.114																																															
<b>epBlue version:</b>	10.3.98.0																																															
Selected log file																																																
Eppendorf	epMotion 5070				17.12.2009																																											
-----																																																
Method name and path :	top/1/as/Test PCR.dws/Simple PCR.dws																																															
Date of Run :	17.12.2009 10:39:05																																															
Last edit :	17.12.2009 10:33:07																																															
Version :	STEUERUNG 6.114																																															
<table border="1"> <thead> <tr> <th>SEQ_NR-</th> <th>TIME----</th> <th>RUN--</th> <th>BGR--</th> <th>FUNCTION-----</th> <th>ERROR--</th> <th>PARAMETER-----</th> </tr> </thead> <tbody> <tr> <td>1</td> <td>10:39:06</td> <td></td> <td></td> <td>LoadProgram()</td> <td>0x0000</td> <td>" Programtop/1/as/Test PCR.dws/Simple PCR.dws, Previously Loaded "</td> </tr> <tr> <td>2</td> <td>10:39:08</td> <td></td> <td></td> <td>LoadProgram()</td> <td>0x0000</td> <td>"Program init begin"</td> </tr> <tr> <td>3</td> <td>10:39:08</td> <td></td> <td></td> <td>LoadProgram()</td> <td>0x0000</td> <td>"Program init ended"</td> </tr> <tr> <td>4</td> <td>10:39:08</td> <td></td> <td></td> <td>LoadProgram()</td> <td>0x0000</td> <td>"Program collect begin"</td> </tr> <tr> <td>5</td> <td>10:39:12</td> <td></td> <td></td> <td>LoadProgram()</td> <td>0x0000</td> <td>"Program collect ended"</td> </tr> </tbody> </table>							SEQ_NR-	TIME----	RUN--	BGR--	FUNCTION-----	ERROR--	PARAMETER-----	1	10:39:06			LoadProgram()	0x0000	" Programtop/1/as/Test PCR.dws/Simple PCR.dws, Previously Loaded "	2	10:39:08			LoadProgram()	0x0000	"Program init begin"	3	10:39:08			LoadProgram()	0x0000	"Program init ended"	4	10:39:08			LoadProgram()	0x0000	"Program collect begin"	5	10:39:12			LoadProgram()	0x0000	"Program collect ended"
SEQ_NR-	TIME----	RUN--	BGR--	FUNCTION-----	ERROR--	PARAMETER-----																																										
1	10:39:06			LoadProgram()	0x0000	" Programtop/1/as/Test PCR.dws/Simple PCR.dws, Previously Loaded "																																										
2	10:39:08			LoadProgram()	0x0000	"Program init begin"																																										
3	10:39:08			LoadProgram()	0x0000	"Program init ended"																																										
4	10:39:08			LoadProgram()	0x0000	"Program collect begin"																																										
5	10:39:12			LoadProgram()	0x0000	"Program collect ended"																																										

- ▶ Select the entry of a run in the list.  
The corresponding log is displayed in the *Selected Log File* section.
- ▶ To print the log, click on *Print* in the toolbar or on File-Print in the menu.

## 4.8 The Labware tab

### 4.8.1 Overview of the Labware tab



This tab is only displayed if you are logged in as a member of a user group with the necessary user rights.

If the *Labware* tab is empty when opened, you first have to open the labware via the *Home* tab (see *The Home tab on p. 38*) or the file window (see *The file window on p. 41*).

epBlue automatically changes to the *Labware* tab if you have opened labware via the *Home* tab or the file window. You can access the empty *Labware* tab also through a mouse click. With the *Labware* tab you can compile labware for use in your system and, provided you have the necessary access rights, can create and edit your own labware combinations.

Generally the *Labware* tab contains the following two editing modes.

If you edit a **Rack and tube combination** or a **Module rack and tube combination** the *Labware* tab displays lists with the available racks, module racks and tubes from which you can select the labware components.

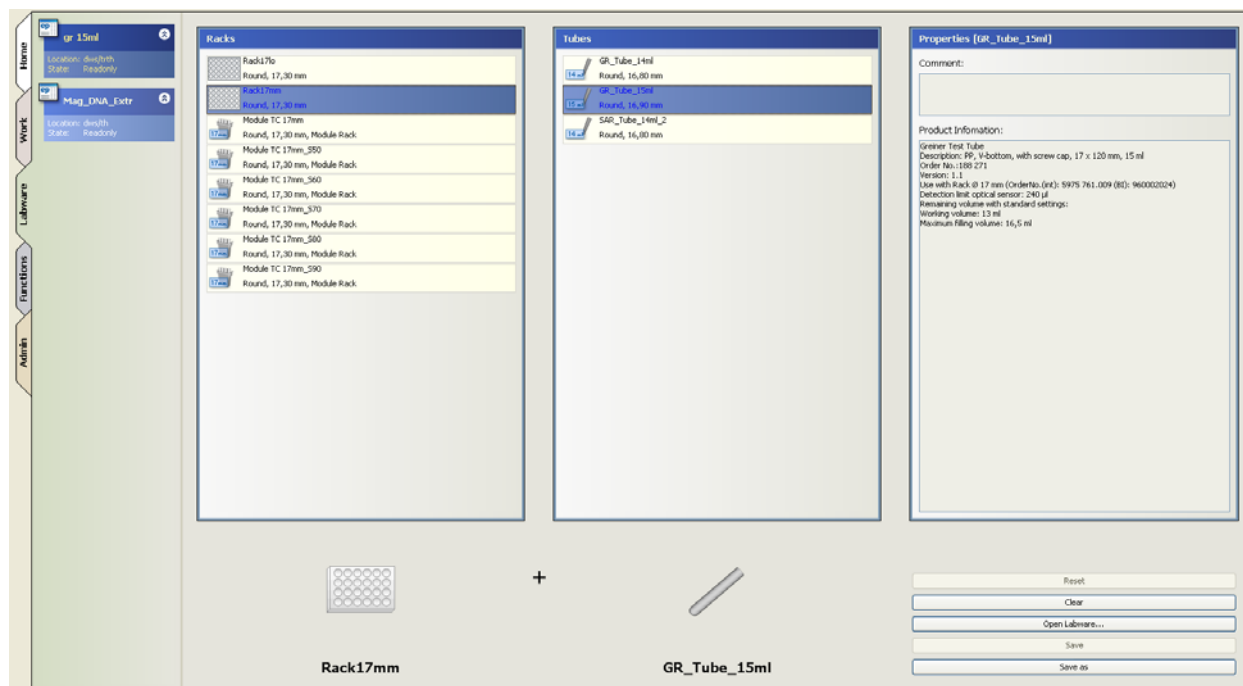

If you fill a **Reservoir rack** the *Labware* tab displays the reservoir rack and you can move different reservoirs and filled module racks into the rack via Drag-and-Drop.

**Holder\_01**  
Location: dws/th  
State: Read / Write

**Available Tubs**

- 15ml Falcon  
Path: dws/th/tubs
- 50ml Falcon  
Path: dws/th/tubs
- Module+EP1\_5ml  
Path: dws/th/tubs
- Module+EP2ml  
Path: dws/th/tubs
- ModulePCR+EP0\_2  
Path: dws/th/tubs
- ModulePCR+EP0\_5\_1  
Path: dws/th/tubs
- EP\_Reserv\_100ml  
Path: dws/th/tubs
- EP\_Reserv\_30ml  
Path: dws/th/tubs
- Module TC Reserv100ml  
Path: dws/th/tubs
- Module TC Reserv30ml  
Path: dws/th/tubs

**Vendor Info:**

Eppendorf epMotion Tub 30 ml  
Description: colorless, with lid, PP  
Order No.(int): 0030 126.505  
Order No.(BI): 960051009  
(Order No.(int): 5075 754.002 Order No.(BI): 960002148  
Only use with Eppendorf Tub-Holder  
Detection limit optical sensor: 3000 µL  
Working volume: 25 mL  
Maximum filling volume: 30 mL

Buttons: Reset, Clear, Open Labware..., Save, Save as

**Reservoir Rack Visualization:**

29mm	30ml	30ml	SL 1,5/2,0	17mm
50ml Falcon	50ml Falcon	EP_Reserv_30ml	EP_Reserv_30ml	Module+EP1_5ml
15ml Falcon	15ml Falcon			15ml Falcon

### List of open labware

On the left-hand side of the *Labware* tab a list with all open labware is displayed. Several labware items can be open at the same time and can be edited in parallel. The current labware is highlighted in darker blue. To switch between the items, click on the labware names in the list.

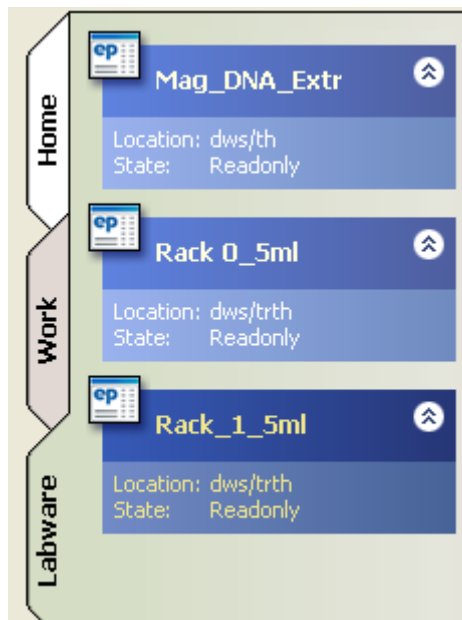

### Icons in the Labware tab

In the *Labware* tab the following icons are available in the toolbar under the main menu.



- New... New Application: to create a new application for editing
- Open... Open Application / Open Labware: to open an existing application or labware
- Save: to save changes to applications or labware
- Print: to print a report
- Logout: to log out of your user account and exit the software

Alternatively, these functions are also available in the File menu.

#### 4.8.2 Activate or deactivate labware

You can activate or deactivate labware for use in your system. If you edit applications, only the active labware is displayed in the *Worktable* tab (see *Worktable tab - equip the worktable on p. 58*). Deactivated labware will not be displayed and cannot be used in applications. You can reactivate deactivated labware at any time.



Before you deactivate labware, make sure that it is not used in any applications. Applications using labware which is not active will not run in your system.

To activate or deactivate labware for use in your system, proceed as follows.

1. Open the labware file window (see *Access to the file window on p. 41*).

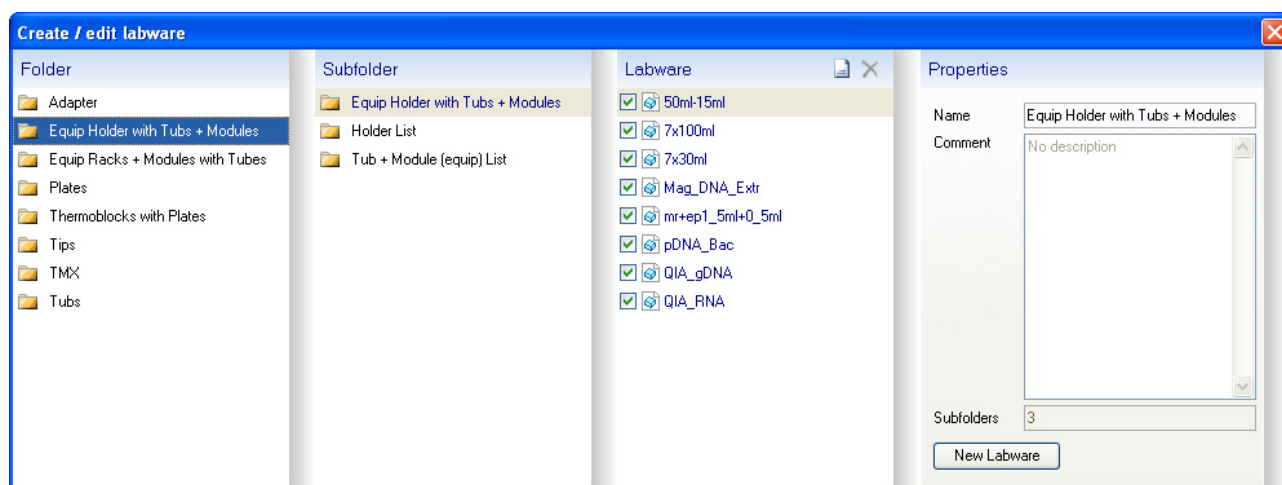

2. Select a labware folder on the left-hand side of the *Folder* list.  
If there are subfolders, these are displayed in the *Subfolder* list.
3. If required, select a subfolder.  
The labware in this folder is displayed in the *Labware* list.  
A checked checkbox next to the labware indicates that this labware is active and can be used in applications.
4. To view additional information on a labware item, select the required labware and click on *Info* in the *Labware Properties* section.
5. Activate or deactivate the labware items as required by clicking the checkboxes.
6. Close the Labware file window.  
The labware you marked as active will be available for use in applications.  
You can change these settings again at any time.

#### 4.8.3 Adjusting the labware bottom tolerance



Bottom tolerance can be adjusted only for some labware types, such as plates, tubes and tubs. You can identify editable labware in the file window easily by clicking on it: if the *Edit Labware* icon is active, you can edit the bottom tolerance for this labware.

Bottom tolerance describes the distance between the calculated bottom of the tube and the calculated lowest part of the pipette tip. The default setting for bottom tolerance for the majority of tubes is 1 mm. For some reservoirs, it is 2.5 mm.

A reduction in bottom tolerance leads to a lower remaining volume and should only be used with expensive reagents. Reduced bottom tolerance should be examined again when changing batch of pipette tips, plates or tubes or if there is doubt about dispensing being correct.

In the case of special tasks, for example removing liquids from above a pellet, it is recommended that the factory-set bottom tolerance should be increased. The user has sole responsibility for the correctness of dispensing and for straightforward aspiration in the case of tubes with altered bottom tolerance.



Adjusting the bottom tolerance for labware is at your own risk.

To adjust bottom tolerance for labware, proceed as follows.

1. Open the labware file window (see *Access to the file window on p. 41*).

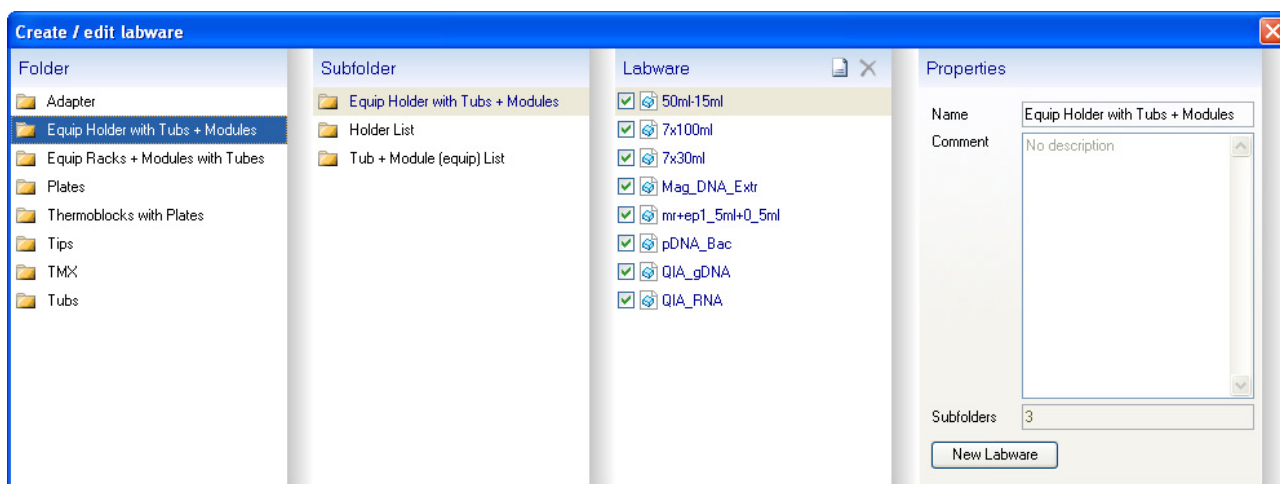

2. Select a labware folder on the left-hand side of the *Folder* list.  
If there are subfolders, these are displayed in the *Subfolder* list.
3. If required, select a subfolder.  
The labware in this folder is displayed in the *Labware* list.
4. In the *Labware* list select the labware for which you want to modify the bottom tolerance.  
The properties of the selected labware are displayed on the right-hand side.
5. To edit the selected labware, click on *Properties*.  
A dialog window appears.

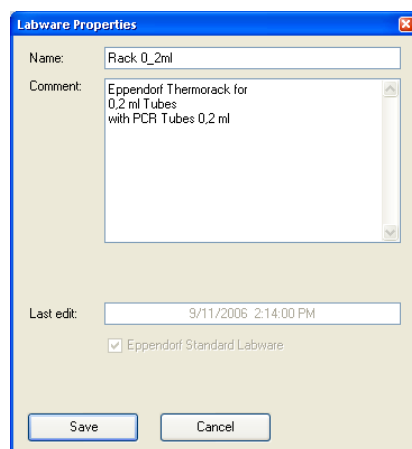

6. Enter the required value in the *Bottom Tol.* field.  
The remaining volume is displayed below. The minimum bottom tolerance is 200 µm.

- Click on *Save* to save the new setting.

The new settings are saved. If the original labware file is read-only (Eppendorf Standard Labware), a copy of the original labware file is created automatically and is saved with the new settings. Copies are numbered consecutively.

A reduced bottom tolerance should be approved for use only following the appropriate test runs. With the 30 mL and 100 mL reservoirs in particular, the reservoir must not be lifted by the pipette tips during aspiration as a result of a reduction in bottom tolerance.

When calculating the Remaining Volume, the minimum immersion depth of 0.7 mm for the pipette tip in the liquid is included in addition to bottom tolerance. With the 30 mL and 100 mL reservoirs, volume information is not absolutely accurate in the case of reduced bottom tolerance (because of the serrated bottom).

In the case of less stable plates it should be noted that the plate could be slightly bent. It is therefore not recommended to reduce bottom tolerance with such plates.

#### 4.8.4 Filling racks and module racks with tubes

You can create your own labware combinations from existing components, e.g., new rack-and-tube or module-rack-and-tube combinations. The module racks you equip here can then be combined with various reservoirs to create your own customized reservoir racks (see *Fill reservoir rack with reservoirs and filled module racks on p. 98*).

To equip a rack or module rack with tubes, proceed as follows.

- Open the labware file window (see *Access to the file window on p. 41*).

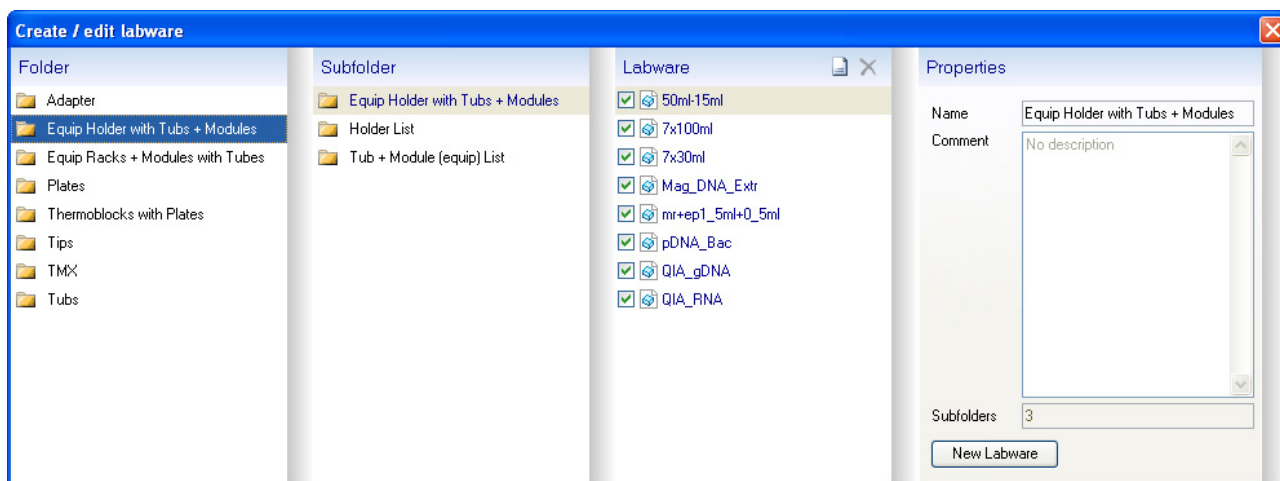

- In the left-hand side of the *Folder* list and in the *Subfolder* list select the folder **Equip Racks + Modules with Tubes**.  
The existing labware combinations in this folder are displayed in the *Labware* list.  
The properties of the selected folder are displayed on the right-hand side.
- To create a new labware combination, e.g., to equip a module rack with tubes, click on *New Labware*.  
A dialog window opens.
- Enter a name for the new labware. If required, enter a short description of the combination in the *Comment* field.<Emphasis/>

- Click on *Create*.

The new labware combination has been created and is displayed in the *Labware* list.

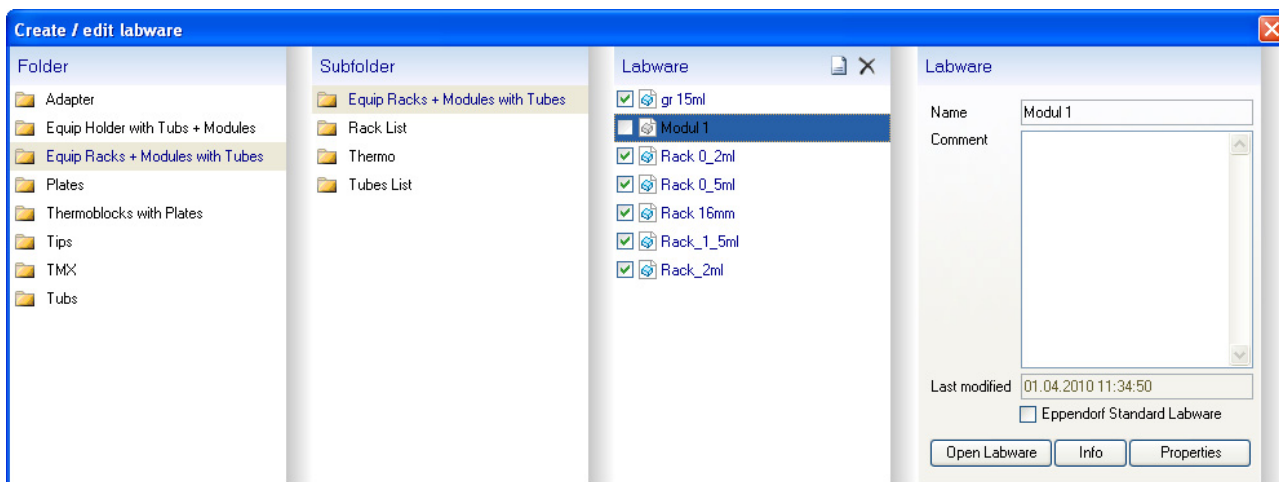

The new labware is opened and displayed in the *Labware* tab.

The *Racks* list on the left-hand side displays the available racks and module racks. The *Tubes* list in the center displays the available tubes with which you can equip the racks and module racks.

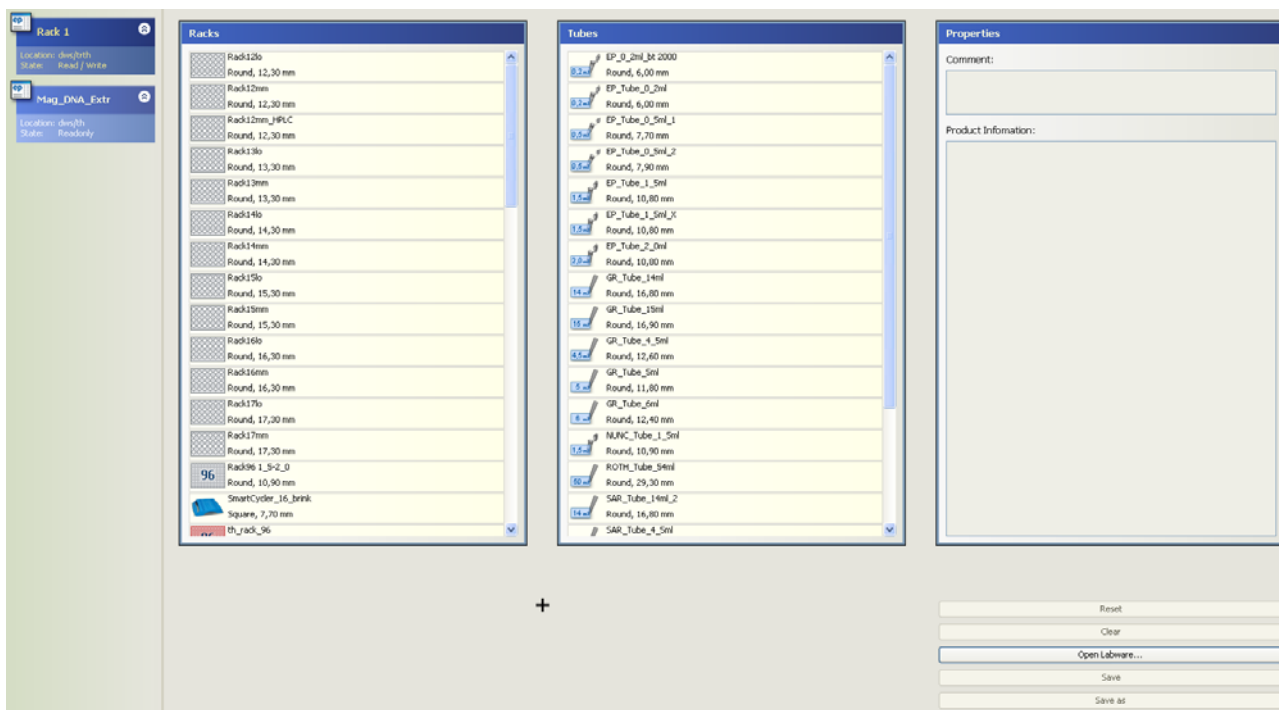

- In the *Racks* list select a rack or module rack. In the *Tubes* list select the appropriate tubes. If you make a selection in the *Racks* or *Tubes* lists, the lists are filtered so that only the components are displayed which can be used in combination with the selected object.

The selected items are displayed as graphics below the list. The **Product Info** field on the right shows additional information on the selected labware.

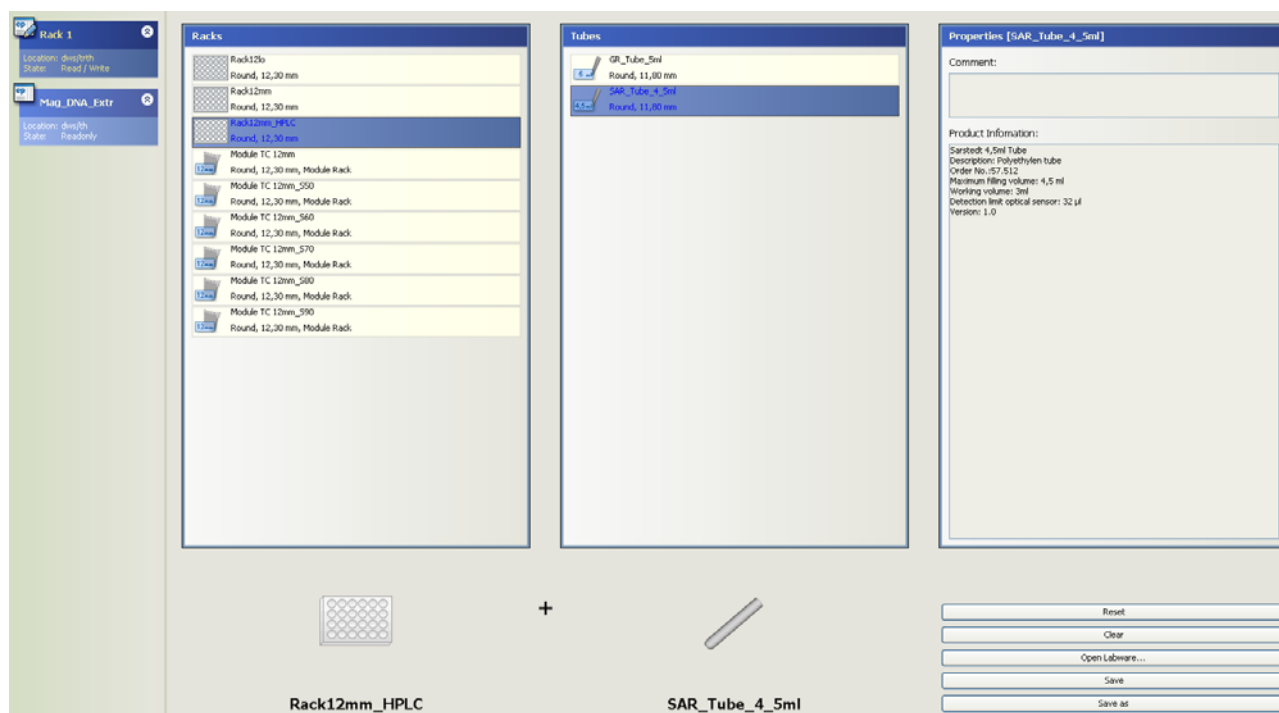

7. To reset both lists and make a new selection, click on *Clear* on the right-hand side.  
For existing labware which you want to change, set the labware back to its basic state with *Reset*. When you create new racks or tubes via *Create Labware*, *Reset* and *Clear* have the same function.
8. When you have selected a rack or module rack and the suitable micro test tubes, right-click on the labware in the list on the left-hand side of the *Labware* tab and click on *Save as* in the context menu or click on *Save as* on the right-hand side of the *Labware* tab.  
The labware combination is saved.
9. To save the combination under a different name, right-click on the labware in the list on the left-hand side of the *Labware* tab and select *Save As* from the context menu.  
A dialog opens.
10. Enter a new name for the labware combination and click on *Save*.  
The labware is saved under a new name and displayed in the *Labware* tab for subsequent editing.
11. Create and edit other required labware combinations in the same way.  
The module racks you have equipped here can now be used to create your own customized reservoir racks (see p. 98).

#### 4.8.5 Fill reservoir rack with reservoirs and filled module racks

You can create your own customized reservoir racks by equipping a rack or holder with various reservoirs or equipped module racks. If you have previously defined your own module-rack-and-tube combinations (see *Filling racks and module racks with tubes on p. 95*), you can now use those equipped module racks in a reservoir rack.

To equip a reservoir rack with reservoirs or equipped module racks, proceed as follows.

1. Open the labware file window (see *Access to the file window on p. 41*).

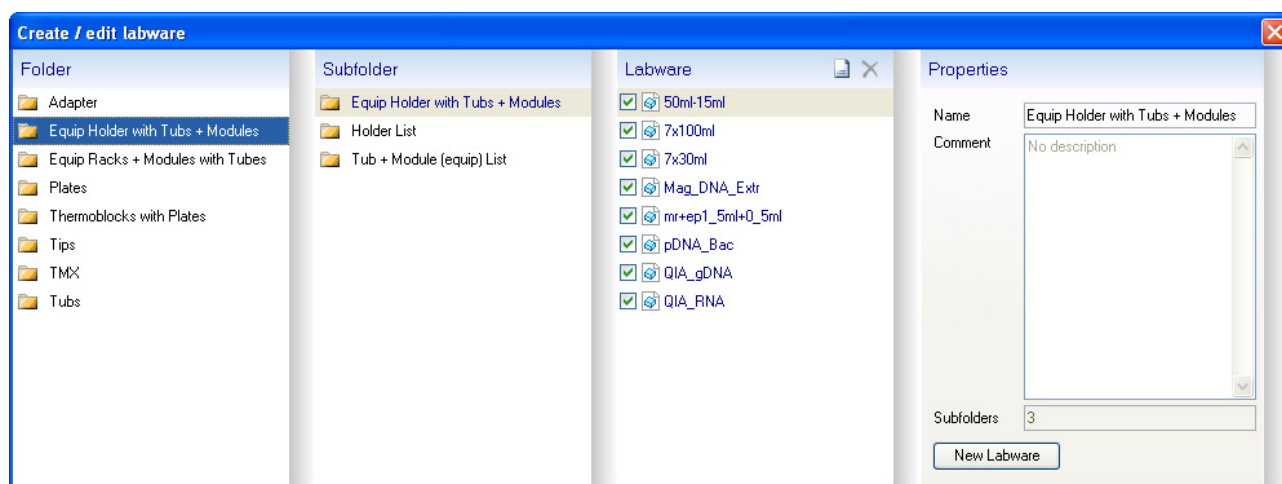

2. In the left-hand side of the *Folder* list and in the *Subfolder* list select the folder *Equip Holder with Tubes + Modules*.  
The existing labware combinations in this folder are displayed in the *Labware* list.  
The properties of the selected folder are displayed on the right-hand side.
3. To create a new labware combination, e.g., a new holder or reservoir rack, click on *New Labware*.  
A dialog window opens.
4. Enter a name for the new labware. If required, enter a short description of the combination in the *Comment* field. **<Emphasis>**
5. Click on *Create*.  
The new labware combination has been created and is displayed in the *Labware* list.

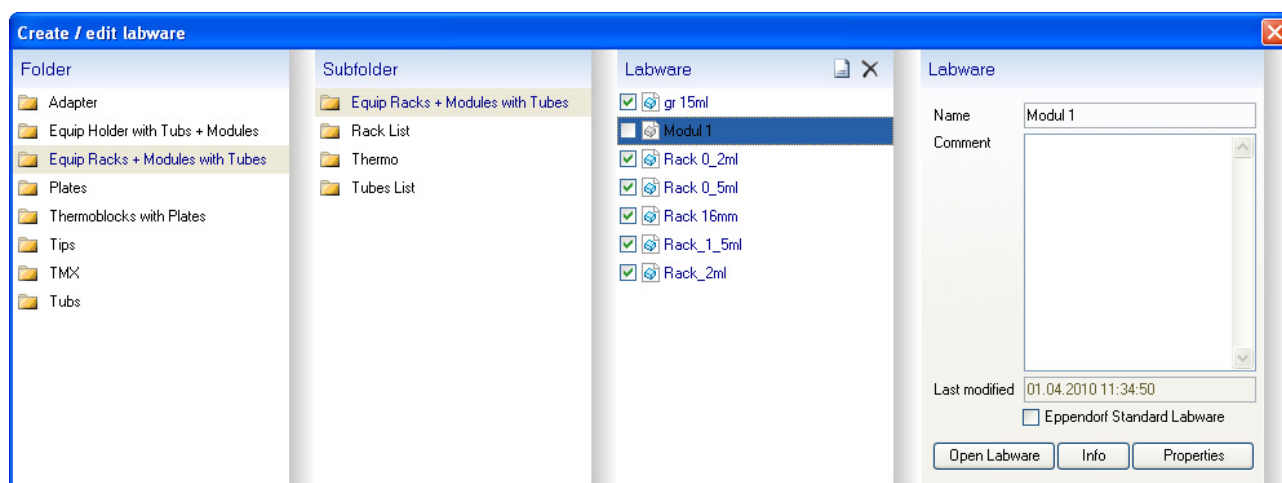

The new labware is opened and displayed in the *Labware* tab.

The list on the left shows the available reservoirs and the equipped module racks which you can use to equip the reservoir rack.

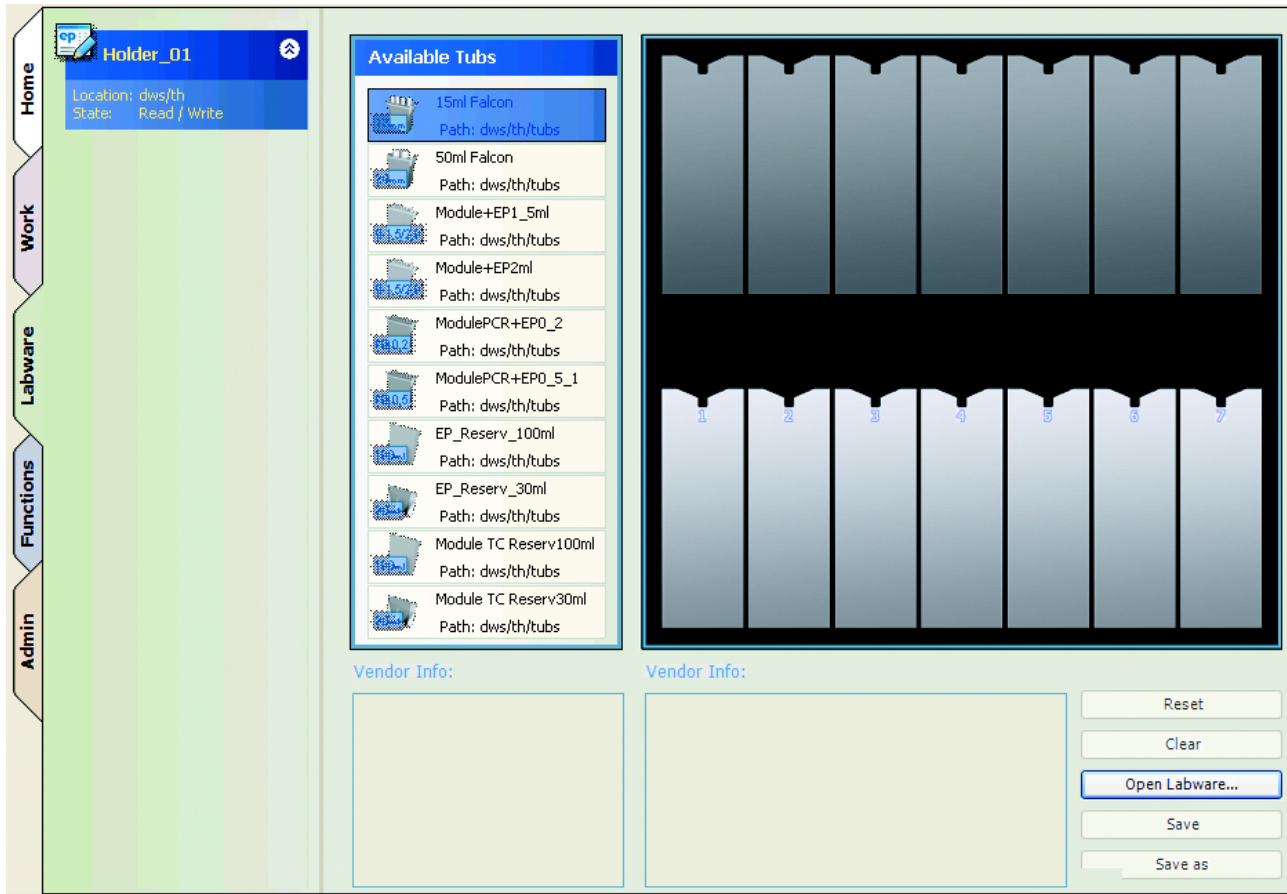

While you are dragging the reservoir or equipped module rack, it is attached to the mouse pointer by its upper left-hand corner. To position it in the reservoir rack, direct the mouse pointer (not the center of the reservoir or module rack icon) to the intended location.

6. Select a reservoir or equipped module rack from the list, drag it with the mouse to its intended location in the reservoir rack and drop it there by releasing the mouse button.  
The reservoir or equipped module rack is displayed in the reservoir rack.



The fields in the lower part of the *Labware* tab show additional information on the labware selected above.

7. To replace an item in the reservoir rack with a different reservoir or equipped module rack, simply drag the new item to the intended location. The old item is removed automatically.
8. When you have equipped the reservoir rack, click on *Save*.  
The combination is saved.
9. To save the combination under a new name right click on the labware in the list on the left-hand side of the *Labware* tab and select *Save As* in the context menu or click on *Save as* on the right-hand side of the *Labware* tab.
10. Enter a new name for the labware combination and click on *Save*.  
The labware is saved under a new name and displayed in the *Labware* tab for subsequent editing.
11. Create and edit other required reservoir racks and module racks in the same way.

## 4.9 The Functions tab

### 4.9.1 Overview of the Functions tab



This tab is only displayed if you are logged in as a member of a user group with the necessary user rights.

The *Functions* tab contains some general functions for configuring the system.



Barcode

Only for a epMotion with epBlue ID and barcode reader.

#### Barcode reader

The top entry on the left-hand side of the *Functions* tab allows you to change the settings for the Barcode reader.

#### List of available devices

On the left-hand side of the *Functions* tab a list with all available devices is displayed. The current device is highlighted in darker blue. To switch between the devices, click on the device names in the list.

#### Two tabs for configuring devices

There are two further tabs within the *Functions* tab:

*Properties*: The *Properties* tab displays a component list and specifies its respective firmware, proxy and server versions.

Properties				
	Component	Firmware Version	Proxy Version	Server Version
Settings	Carrier	STEUERUNG 4.154	00.09	00.09
	Control	STEUERUNG 4.154	00.07	00.07
	Dosing device	WZHALTER.HEX 00.23	02.03	02.03
	Dosing motor	WZHALTER.HEX 00.23	00.01	00.01
	Levelsensor	WZHALTER.HEX 00.23	00.01	00.01
	Process control	STEUERUNG 4.154	01.19	01.19
	Tool interlock	WZHALTER.HEX 00.23	00.02	00.02
	X-Axis	STEUERUNG 4.154	00.01	00.01
	Y-Axis	Y-ACHSE.HEX 00.05	00.01	00.01
	Z-Axis	Z-ACHSE.HEX 00.05	00.01	00.01

*Settings*: The *Settings* tab displays general information and you can execute service functions through it as described in the following sections.



#### 4.9.2 Barcode reader



Barcode

Only for a epMotion with epBlue ID and barcode reader.

Use this function to change the settings of the barcode reader.

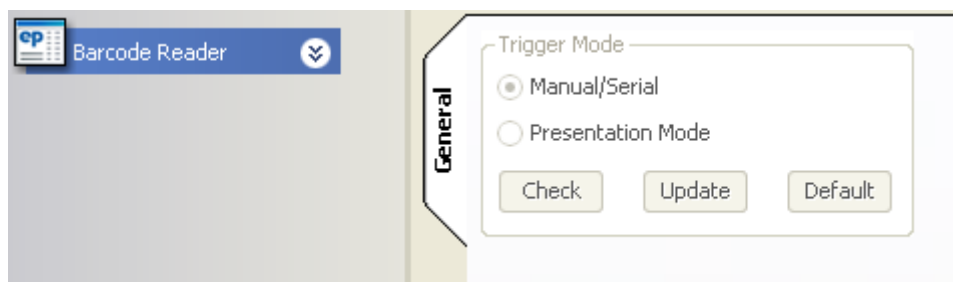

► **Trigger mode:**

- Activate *Manual/Serial* to read barcodes by pressing the key on the barcode reader.
- Activate *Presentation Mode* if the barcode reader should automatically and continually scan for barcodes.

Use *Check* to verify the current setting of the reader. After completing the changes, press *Update*. Use *Default* to reset the reader to *manual/serial*.

#### 4.9.3 Optical sensor

Use this function to set the general level sensor settings.

To do so, proceed as follows.

1. Select the function *Optical Sensor* in the *Settings* list.  
The current settings are displayed on the right.



The following options are available:

- *Levels*: check the liquid levels according to the settings defined for the individual labware items.
  - *Tips*: check the type and quantity of tips in the tip rack.
  - *Locations*: check that the labware is positioned correctly on the worktable, as specified in the method.
2. Activate or deactivate the options as required, and click on *Apply*.  
The new level sensor settings are active.

#### 4.9.4 Tool interlock

To unlock the tool in case of a system error. This function allows you to control the locking mechanism of the carrier which locks the dispensing tool in position when it is taken up by the carrier.

To control the tool interlock, proceed as follows.

1. In the *Settings* list select the function *Tool interlock*.  
The current settings are displayed on the right.

The *State* section displays the current lock status.

- **Zero value sensor**: shows the status of the sensor which checks that the tool is in zero position.
- **Tool detection sensor**: shows the status of the sensor which identifies the tool in the carrier.
- **Interlock**: shows the current status of the tool interlock.
- **Current Tool**: if there is a tool in the carrier, it is identified and displayed here.



While you operate the locking mechanism, hold the tool firmly in position with one hand. Otherwise it will drop out of the locking mechanism and be damaged.

2. Click on *Lock* or *Unlock* to lock or unlock the tool.

#### 4.9.5 Firmware Update

With this function you can execute a **Firmware Update**.

1. In the *Settings* list select the function *Firmware Update*.

2. Under *Flashfile*, specify the location of the new firmware file.
3. Click on *Flash*.  
The firmware update is carried out. The progress is shown under *State*.
4. When the firmware update is complete, exit the client and the server software. Then restart first the server, then the client software.

#### 4.9.6 Dosing device

Use this function to check the strokes of the dosing device for maintenance and calibration purposes.

Insert a tool and lock it with the *Tool interlock* function.

- *Tool used*: Name of the tool.
- *Tool path*: File path of the tool specification file.
- *Strokes*: Strokes of this dosing device.



Don't forget to remove the tool:

1. Hold the tool with one hand.
2. Unlock the tool carrier with the *Tool interlock* function.

## 4.10 The Admin tab

### 4.10.1 Logging in as administrator



#### Loss of data due to misuse or loss of the administrator password.

The administrator password protects the system against unauthorized access to the configuration and the stored data of all users.

- ▶ Make a note of the administrator password and keep it in a safe place. If you lose the administrator password, contact Eppendorf Service.
- ▶ Provide the administrator password only to persons who are permitted to edit the configuration of the system and who have the necessary skills to do this.



In order to prevent unauthorized access to the system, it is strongly recommended that you change the default administrator password as soon as possible (see *The Admin tab on p. 105*). It is recommended that you create individual user accounts for every operator who will use the epMotion 5070 (see *Creating the first user account on p. 29*).

To log in as administrator, proceed as follows.

1. To start epBlue, double-click on the **Eppendorf epBlue** icon on the desktop, or select **Start - Programs - Eppendorf - epBlue** in the Windows Start menu.  
The login screen appears.
2. Enter the account name "administrator" and the administrator password (the default is "Admin123!"), and click on *Login*.  
epBlue starts and the program window displays the *Home* (see *Overview of the Home tab on p. 38*) tab. You are logged in as administrator.
3. Select the *Admin* tab on the left-hand side of the program window.

### 4.10.2 Overview of the Admin tab

The *Admin* tab is only displayed if you are logged in as administrator. It allows you, as administrator, to manage user accounts and groups.

In the left-hand column of the *Admin* tab you can change between **Account**, **Group**, **Extra**, **Device List** and **Backup/Restore**. If you are logged in as **Admin Lab**, in the *Admin* tab, you will be able to change between *Barcode Settings* and *Print headers*. The current selection is highlighted.

Account	Personal		Company	Telephone Number		Profile	
	Firstname	Lastname		Branch	Email	Member Of	Disabled Until
▶ administrator	Administrator					Administrator	01.04.2010 12:58:47
as						Administrator Lab	01.04.2010 12:16:21
user2						User Level 2	01.04.2010 10:31:32
Sophie						User Level 2	01.04.2010 10:31:44

#### Account

When *Account* is selected in the left-hand column of the *Admin* tab, there are two tabs for editing user accounts:

- *Account Overview*: shows a list of all user accounts and gives you some information about every user (see p. 108).
- *Edit Account*: allows you to create new user accounts or edit existing accounts (see p. 109).

## Group

If *Group* is selected in the left-hand column of the *Admin* tab, the *Group Overview* tab displays a list containing all the user groups and the user rights defined for each group (see p. 114).

## Extra



### Malfunctions when connecting additional clients.

- ▶ Use only software approved and tested by Eppendorf AG.
- ▶ If you connect an additional client (e.g., PC or laptop) yourself and reconfigure the system, you take sole responsibility for this.
- ▶ Only install and configure an extra client if you have adequate experience of the relevant network and system configuration tasks.
- ▶ Integrate and configure an additional client into a cooperation network, only let an IT specialist do it who can also take over Support.
- ▶ Before installation, you should perform a data backup on the prospective client.
- ▶ Eppendorf AG expressly accepts no warranty for epBlue software functioning on the client together with other programs selected by the licensee.
- ▶ Eppendorf AG likewise accepts no liability for any damages or consequential damages (such as loss of profit, interrupted operations, loss of information or data) which may occur. This does not apply where compulsory liability is prescribed by law, in accordance with product liability law for example, in cases of intent, gross negligence, where there is loss of life, injury or impairment to health or if substantial contractual obligations are breached.
- ▶ Eppendorf AG does not give any support for any additional clients configured on the industry PC.

If *Extra* is selected in the left column of the *Admin* tab, the *Network* tab is available:

### Network - setting up a new client

If you have selected *Extra* in the left-hand column of the *Admin* tab you can establish a point-to-point Ethernet connection to a second client. To this end, the client software (epBlue) is installed on a second computer without server (see "Remote Client and Network Setup Guide"). The client must be connected to the server computer (integrated industrial PC) by an Ethernet crossover cable. To enable the second client to have access to the server, the second network connection of the server PC must have an IP address assigned to it:

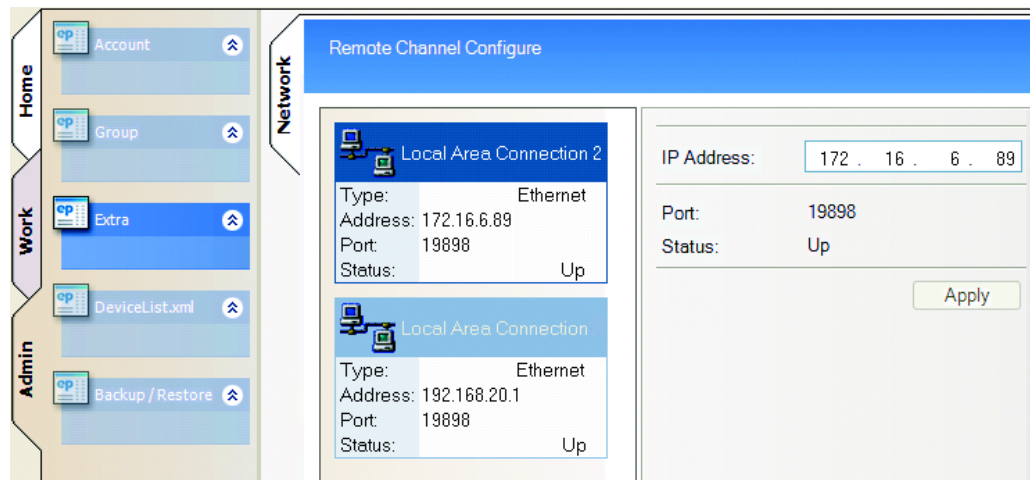

The network interface card of the second client needs the IP address of the server to get access:

1. Select the *Network* tab in the *Extra* tab of the *Admin* section of the server PC.
2. Select the field on the left, *Local Area Connection 2*.
3. Enter an IP address on the right.

The IP address should be 192.168.XXX.YYY. Do not use "20" or "020" for the numbers "XXX". This must not be the same as the IP address for the *Local Area Connection* or another IP address, which is already assigned to a device. The *Local Area Connection* is the connection to the device. By default, the server's IP address is 192.168.20.1, the device's IP address 192.168.20.2.

4. Adopt the IP address by clicking on *Apply*.

When the second client starts up, select the IP address quoted for the second network connection at *Server* in the login window. The second client now has access to the data of the server on the other computer.

### Device list

Here you can see information on all the connected devices. By default the name of the device is its serial number. You can change the name if necessary.

- Confirm your changes with *Apply*.

### Backup/Restore



**NOTICE!**

#### Data loss due to lack of data backup or incorrect storage of data carriers.

epBlue saves all information on user accounts, applications, labware and logfiles in a database on the epMotion PC. Damage to this database (e.g., due to a hardware fault) causes this information to be lost.

- ▶ Carry out regular database backups via the function *Backup* in *Admin* tab.
- ▶ Save the backup file on a secure data carrier and store it in accordance with the manufacturer instructions.

Eppendorf is not liable for data loss and its consequences.

When *Backup/Restore* is selected in the left-hand column of the *Admin* tab, there are two tabs for editing user groups:

- *Backup*: In the upper part you can make entries for automatic backups.
  - a Activate the *Create full Backup every* checkbox to automatically create a full backup. The interval for the backups can be entered in days to the right.
  - b Specify a path under which the backup should be stored.
  - c End your input with *Apply* when your changes should be adopted.
  - d Press *Reset* to delete all the entries again.



The epBlue client must not be connected to the epBlue server when an automatic backup is performed. epBlue checks whether the epBlue client is closed. If the epBlue client is not closed, the automatic backup is not performed and an error message is generated.

- In the bottom part you can define the settings for a manual backup.
  - a The *Backup type* is set to full backup. A name for the backup is automatically generated. You can change this name manually.
  - b On the right-hand side, enter a path under which the backup should be saved.
  - c Enter further information in the detail window.
  - d Press *Run* to create the backup.

A status display and a progress bar show the progress of the backup.

- *Restore*: You can define settings for your restore here.
  - a The *Restore type* is set to full restore.
  - b Below specify the path under which the backup file is stored.
  - c Enter further information in the detail window.
  - d Press *Run* to restore the backup.

A status display and a progress bar show the progress of the restore.



The *ID List Settings* and *Print headers* options are only shown if you are logged in as **Admin Lab**.

### ID List Settings



Barcode

Only for a epMotion with epBlue ID and barcode reader.

This area is only visible to **Admin Lab**.

1. Configure whether 1 or 2 IDs are to be used for reagents to be processed using a reagent transfer, e.g., to document the reagent type and batch number of expiry date in the method log.
2. Define the file type (CSV or XML) for import and export.
3. Define a default file path for import and export.
4. Confirm changes with *Apply*.

### Print headers

This area is only visible to **Admin Lab**.

You can make changes to the header area of your printouts here.

1. Activate the *Edit print header template* checkbox.
2. Make changes in the right-hand text window if necessary.
3. Select a different header or image file 2 lines below the checkbox above the right-hand button and save it by clicking on the *Save Header* button.
4. Define a default header area with *Set as default header*.
5. Delete an imported file with *Delete Header*.
6. Click on the *Show preview* button to show the new header area.

### 4.10.3 Account Overview

The *Account Overview* tab in the *Admin* tab provides an overview of all user accounts registered in your system.

Account Overview						
Account	Personal			Profile		
	Firstname	Company	Telephone number	Home	Member of	
	Lastname	Branch	Email	Registered on	Expire on	
administrator	Administrator			sp	Administrator	
service	Service			dws	Service	
Susanne	Susanne		user@eppendorf.de	4/8/2006	Administrator	

The overview contains the following information.

- **Personal Info:** the user's full name and contact information.
- **Profile Info:** the user's home directory, the date of registration of the user account and, if applicable, its expiry date.
- **Groups:** the user groups to which the user belongs. The user inherits the user rights defined for the selected group or groups.

To create or edit user accounts, go to the *Edit Account* tab.

#### 4.10.4 Edit accounts

The *Edit Account* tab in the *Admin* tab provides functions for creating new or editing existing accounts. The Account List on the left-hand side displays the user accounts in your system.

You can create new user accounts (see p. 109), edit existing accounts (see p. 111), delete accounts (see p. 112), and change the password for an account (see p. 112).

#### Create new user account

To create a new user account, proceed as follows.

1. Select **Account** in the left-hand area of the Admin tab to highlight it in dark blue and then select the *Edit Account* tab.
2. Click on *New Account*.

The following form is displayed.

3. In the *Account* field, enter an account name for the new user.
4. In the *Password* and *Confirm password* fields, enter the password for the new user account. If the entries in the two fields do not match exactly, a message will be displayed. In this case, delete the contents of both fields and enter the password again.

5. In the *Member of* section, activate the user group to which you want the new user to belong. The user will have the user rights defined for the selected group.
6. If you want to enable the account for a certain period of time, activate the *Account valid until* option and enter the expiry date there.

You also have the option to lock the account until a certain day. To do this, activate the *Disabled until* option and enter the expiry date there. A disabled account can be enabled again by the administrator at a later time (see *Editing a user account on p. 111*).



Each user name can only be used once, even if it has already been deleted once.

- 
7. If you wish, you can enter further information about the new user, e.g., the user's name and contact information. This information is optional. If you enter the name of the user he or she will be addressed by this name in the *Home* tab after login. Otherwise the account name will appear.
  8. Click on *Submit*.  
The new user account is created. The user name appears in the Account List in the *Edit Account* tab.
  9. If required, create further user accounts in the same way.
  10. When you have finished, log out as administrator to prevent unauthorized access to the system.

## Editing a user account

To edit an existing user account, proceed as follows.

1. Select the *Edit Account* tab in the *Admin* tab.
2. In the Account List on the left-hand side, select the user you want to edit.
3. Click on *Edit Account*.

The user account settings are displayed.

4. In the *Member of* section, activate the user group to which you want the user to belong. The user will have the user rights defined for the selected group.
5. If you want to enable the account for a certain period of time, activate the *Account valid until* option and enter the expiry date there.  
You also have the option to lock the account until a certain day. To do this, activate the *Disabled until* option and enter the expiry date there. A disabled account can be enabled again by the administrator at a later time (see *Editing a user account* on p. 111).



Each user name can only be used once, even if it has already been deleted once.

6. If you wish, you can enter further information about the new user, e.g., the user's name and contact information. This information is optional. If you enter the name of the user he or she will be addressed by this name in the *Home* tab after login. Otherwise the account name will appear.
7. Click on *Submit*.  
The changed settings for this user account are now active.
8. If required, edit other user accounts in the same way.
9. When you have finished, log out as administrator to prevent unauthorized access to the system.

### Deleting a user account

To delete a user account, proceed as follows.

1. Select the *Edit Account* tab in the *Admin* tab.
2. In the Account List on the left-hand side, select the user you want to delete.
3. Click on *Remove Account*.

The user account settings are displayed.

4. Click on *Remove*.  
A message appears.
5. To keep the account, click on *No*.
6. To delete the account, click on *Yes*.  
The account is deleted.
7. When you have finished, log out as administrator to prevent unauthorized access to the system.

### Change password



Every user can change his or her own password at any time by selecting *Tools - Account - Change Password* from the main menu.

If a user has lost his or her password, the administrator can change the user's password, e.g., reset it to a standard password. In this case, the user should then change the standard password to a personal password as soon as possible to prevent unauthorized access to the system.

To change the password for a user account, proceed as follows.

1. Select the *Edit Account* tab in the *Admin* tab.
2. In the Account List on the left-hand side, select the user whose password you want to change.

- Click on *Change Password*.  
The following form is displayed.

The screenshot shows a web interface titled 'Edit Account'. On the left, there is a vertical sidebar with 'Overview' and 'Edit' tabs. Below 'Edit' is an 'Account List' containing three entries: 'administrator', 'service', and 'Susanne'. The 'Susanne' entry is highlighted. The main content area is titled 'Enter your Password' and contains a 'Password:' field. Below this is a section titled 'Change your Password' with 'New Password:' and 'Confirm password' fields. At the bottom right are 'Submit' and 'Cancel' buttons.

- In the **Password** field, enter the current password.
- In the **New Password** and **Confirm password** fields, enter the new password. If the entries in the two fields do not match exactly, a message will be displayed. In this case, delete the contents of both fields and enter the new password again.
- Click on *Submit*.  
The new password for this user account is now active.
- When you have finished, log out as administrator to prevent unauthorized access to the system.

#### 4.10.5 Set up a new password

If a user has lost the password, the administrator can change the user's password.  
To set a new password for a user account, proceed as follows

- In the *Admin* tab select the *Account* item and go to the *Edit* tab.
- In the *Account List* select the user whose password has been forgotten on the left-hand side.
- Click on *Set a new password*.  
The following form is displayed.

The screenshot shows the same 'Edit Account' interface. In the 'Account list' on the left, 'Ute' is now highlighted. The main content area is titled 'Selected account' and shows 'Account: Ute'. Below this is a section titled 'Create a new password' with 'New password:' and 'Confirm password:' fields. At the bottom right are 'Submit' and 'Cancel' buttons.

- Enter the new password in the *New Password* and *Confirm Password* fields.  
If the entries in the fields do not match exactly, a message is displayed. In this case, delete the contents of both fields and enter the new password again.
- Click on *Submit*.  
The new password for the selected user account is active.
- Log out as administrator to prevent unauthorized access to the system.

#### 4.10.6 Group overview

The *Group Overview* tab in the *Admin* tab displays a list of all user groups and the access rights defined for each group.

Group Overview					
Group	Administrator	Administrator Lab	User Level 2	User Level 1	Guest
Fixed	<input checked="" type="checkbox"/>	<input checked="" type="checkbox"/>	<input checked="" type="checkbox"/>	<input checked="" type="checkbox"/>	<input checked="" type="checkbox"/>
Application					
Create and edit application		X	X	X	
Simulate application		X	X	X	X
Start application		X	X	X	X
Barcode					
Barcode settings		X			
Remove barcode list		X			
Data					
Backup data	X				
Export data	X	X	X		
Import data	X	X	X		
Print data		X	X	X	
Restore data	X				
Labware					
Activate and deactivate labware		X	X		
Create and edit labware		X	X		
Services					
Applied services		X			
System					
Configure system	X				
Manage account	X				
Setup hardware	X				
Setup software	X				

The overview contains the following information.

- **Group:** each group is displayed in a separate table column.
- **Fixed:** this checkbox is set for all groups because the user groups cannot be modified.
- **System, Application, Labware etc.:** the available user rights are listed. The rights that are active for a user group are marked with an X in the respective table cell.

The following user groups are available. For exact details of user groups and access rights in your system, please check the group overview for your system.

- **Administrator:** members of the Administrator group can manage user accounts and user groups and have access to some service functions. They are authorized to configure the system, set up hardware and software, backup and restore data and also to import, export and print data.
- **Admin Lab:** members of the Admin Lab group have access to application-related service functions. They are authorized to create, edit and run applications, edit and manage labware and also to import, export and print data.
- **User Level 2:** members of the User Level 2 group can create, edit and run applications, edit and manage labware and also import, export and print data.
- **User Level 1:** members of the User Level 1 group can create, edit and run applications and also print data.
- **Guest:** members of the Guest group can run applications.

## 5 Quick start

### 5.1 Short instructions



Only trained staff already familiar with the operating manual and the epMotion may work to the short instructions. Observe the safety precautions.

#### 5.1.1 Select and start the epMotion method

1. Double-click on the **Eppendorf epBlue** icon on the desktop, or select **Start - Programs - Eppendorf - epBlue** in the Windows Start menu.  
epBlue starts, and the login screen appears.
2. Enter your account name and your password.
3. Click on *Login*.  
epBlue starts and the program window displays the *Home* tab.
4. Click on *Open / run applications* in the *Tasks* area of the *Home* tab or click on the icon *Open* and select *Open Application* or select *File - Open / run applications* in the main menu.  
The file window opens.
5. Open the user directory and the folder containing the epMotion method you want to start. Select the method and click on *Open Application*.  
If the method is suitable for more than one device in your system, a list of devices is displayed.
6. Select the device you want to use and click on *OK*.  
The method opens and the program window changes to the *Work* tab.
7. In the *Work* tab select the *Worktable* tab and check the equipment of the worktable. Check whether the labware shown in the display is available at the corresponding locations in the worktable and whether all locations identified as empty in the display are actually empty.
8. Check whether the tip racks are sufficiently filled with tips, whether all tubes are open and whether the waste basket is empty.
9. Close the front hood.
10. Change to the *Run* tab and activate the option *Filter Device List* to display only devices that are online and suitable for the method.
11. Select the device you want to use and click on *Run*.  
The method is loaded on the selected device.  
If the number of samples for each step in the procedure has been defined as variable, a window opens.
12. Enter the number of samples and click on *OK*. If required, enter the number of samples for further commands in the same way.
13. To edit labware-specific configurations for the level sensor and the volumes, double click on the labware in the *Worktable* area of the *Run* tab or right click on the labware and select *Properties* in the context menu.
14. To define the level sensor configurations for this method run, activate or deactivate the corresponding options.  
The level sensor can execute the following scans.
  - *Levels*: check the liquid levels according to the settings defined for the individual labware items.
  - *Tips*: check the type and quantity of tips in the tip rack.
  - *Locations*: check that the labware is positioned correctly on the worktable, as specified in the method.

15. Click on *Run*.
16. If necessary enter the liquid levels for the labware objects for which the Liquid Detection has been deactivated and click on *Run*.  
The method starts and the display changes to the *Control* tab. The progress and current status of the method is displayed. A message appears when the method run is complete.
17. To cancel the method before it is complete click on the icon *Stop* in the *Control* tab. The method stops. Then click on the *Abort* icon to abort the method.

## 5.2 Example method for epMotion

### 5.2.1 Method objective

Liquid such as a reagent is to be dispensed from a 30 mL reservoir in a Reservoir Rack into 16 wells of a PCR 96 plate. 16 samples from a Thermorack supplied with 1.5 mL Eppendorf micro test tubes are then transferred into the same wells of the PCR 96 plate.

### 5.2.2 Sample preparation

1. Supply the Reservoir Rack with a 30 mL reservoir. Manually fill this reservoir with any volume.
2. Supply the Thermorack with 16 1.5 mL Eppendorf micro test tubes. Put any desired sample volume in these tubes.

### 5.2.3 Creating the example method



The following sections describe the steps for creating the example method specified above. To follow these instructions, you must be familiar with the operating manual and the epMotion. Follow the safety notes at all times. If you are not sure, please refer to the detailed description of the Work tab (see *The Work tab* on p. 53).

## Logging in and creating a new method

1. Log in to your user account.
2. Click *Create / edit applications* in the *Tasks* section of the Home tab, or click the *New* icon and select *New Application*, or select *File - Create / edit applications* from the main menu.  
The file window opens.

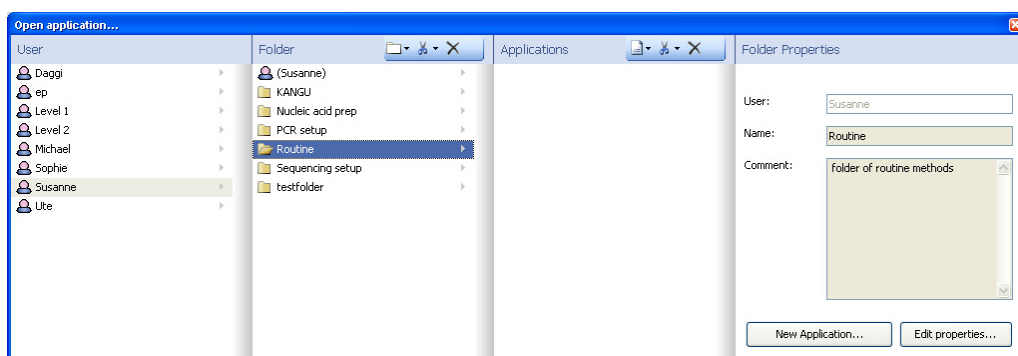

3. In the User list on the left hand side, select your user name to access your user directory.
4. In the Folder list, select the folder in which you want to create the new method.

- Click *New Application*, or right-click in the Applications list and select *New Application* from the context menu, or click the *Create new application* icon above the Applications list.

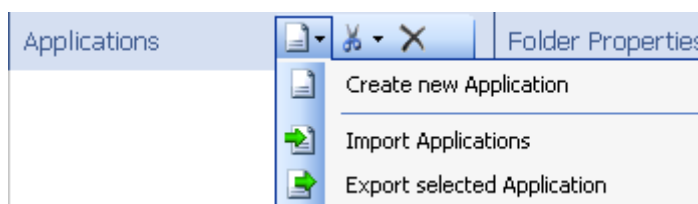

The following window opens.

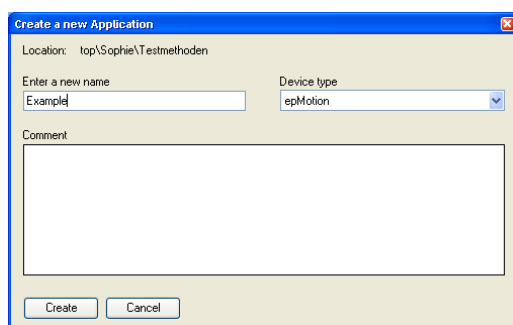

- Enter a name for the new method. If required, enter a short description of the method in the Comment field.
- In the Device type list, select *epMotion*.
- Click *Create*.

The new method is created and displayed in the Applications list.

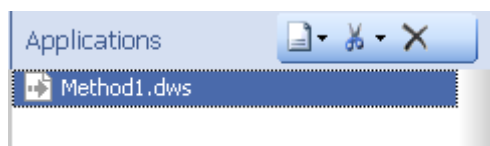

The method opens, and the program window switches to the Work tab.

### Supplying the worktable

- In the Work tab, select the Worktable tab to supply the worktable with the labware required for your method.
- In the Labware Type and Subtype lists, select *Equipped Holders*. In the Labware list, select select the Reservoir Rack *7x30ml*.

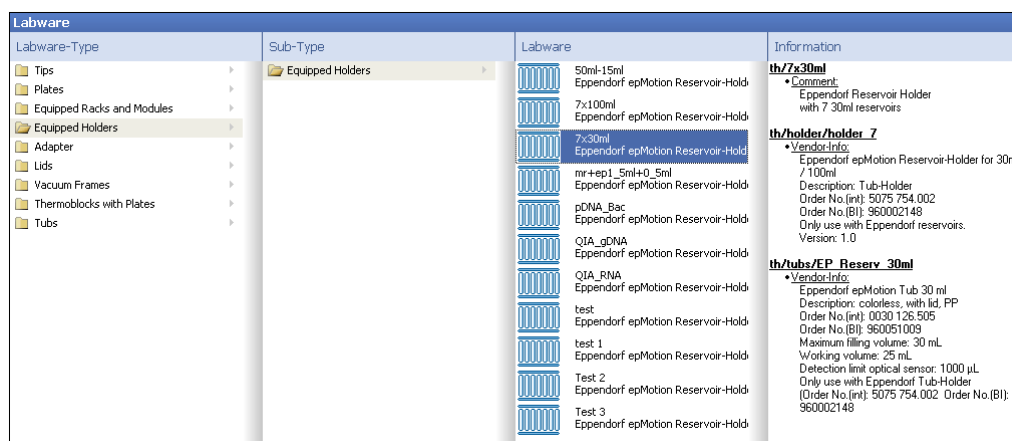

- Right-click and drag the Reservoir Rack upwards with the mouse, then drop it in location B1.

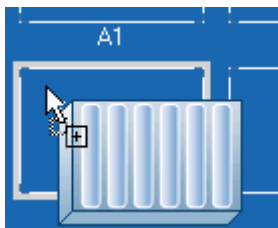

A dialog window opens, displaying information about the Reservoir Rack which has been positioned.

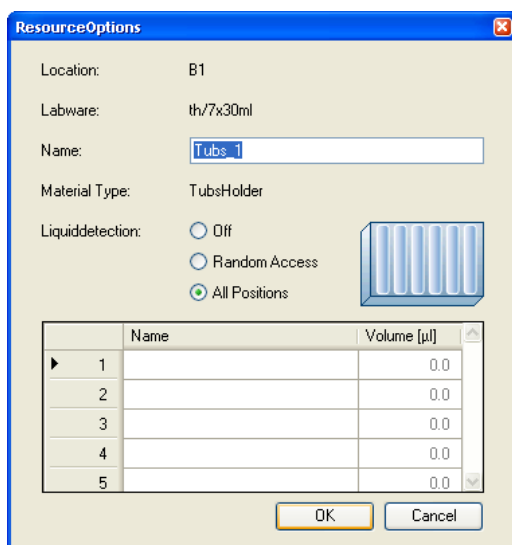

- Check whether *All positions* is marked for liquid detection by the optical sensor, and click *OK*.
- Under *Tips* in the Labware list, select the 300 µL tips (*tip300*).

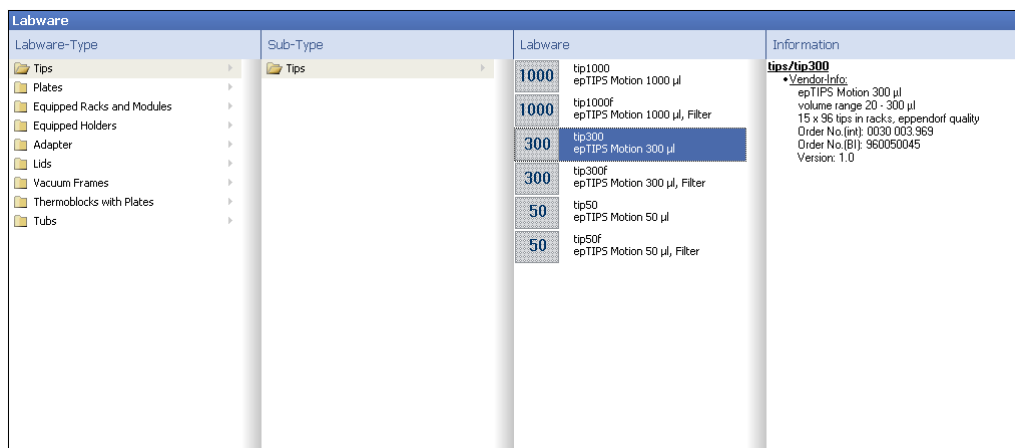

- Right-click and drag the tips upwards with the mouse, then drop it in location A1.

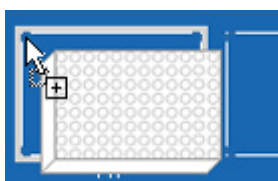

A dialog window opens, displaying information about the Reservoir Rack which has been positioned.

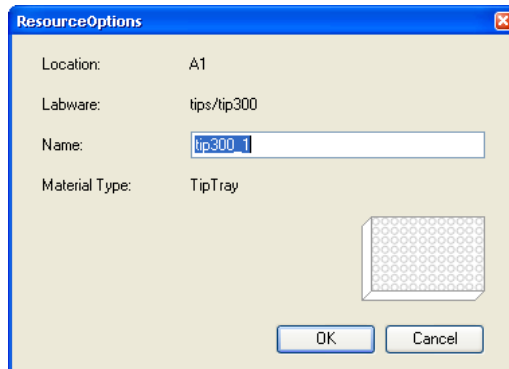

7. Click *OK*.
8. Under *Equipped Racks and Modules* select the thermorack (*Rack\_1\_5\_mL*).

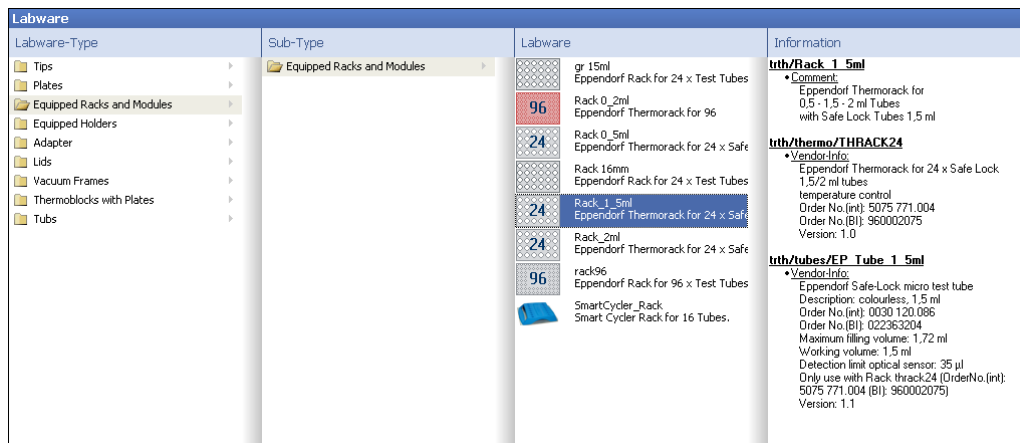

9. Position the thermorack in location B2.

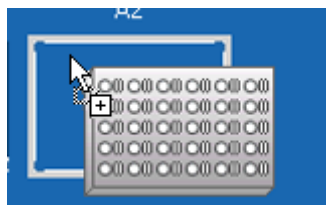

10. In the dialog window, check whether liquid detection is set to *All Positions*, and click *OK*.

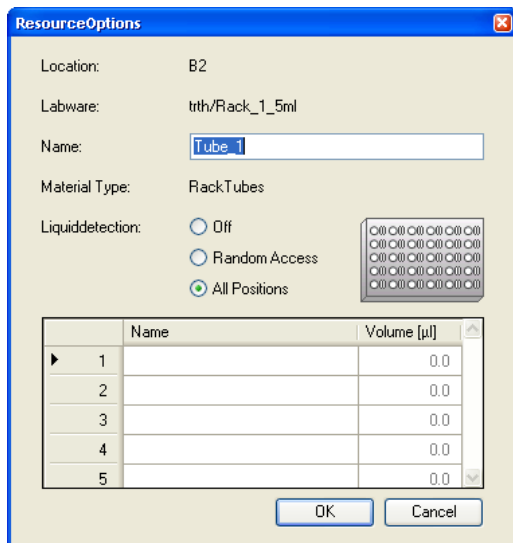

11. Under *Plates* and *pcr96*, select PCR plate *EP\_TT\_PCR\_150*.

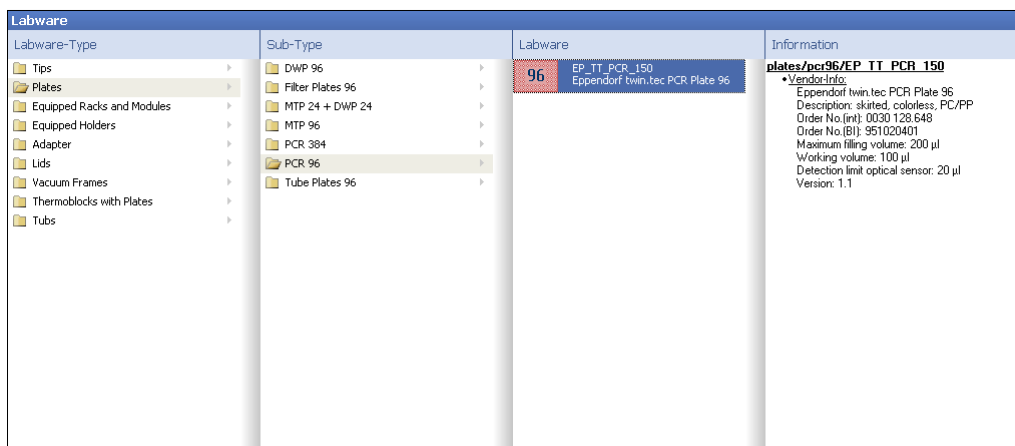

12. Position the plate in location A2.

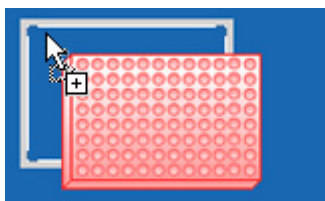

13. In the dialog window, check whether liquid detection is set to *Off*, and click *OK*. Liquid detection is very time-consuming for plates with 96 wells.

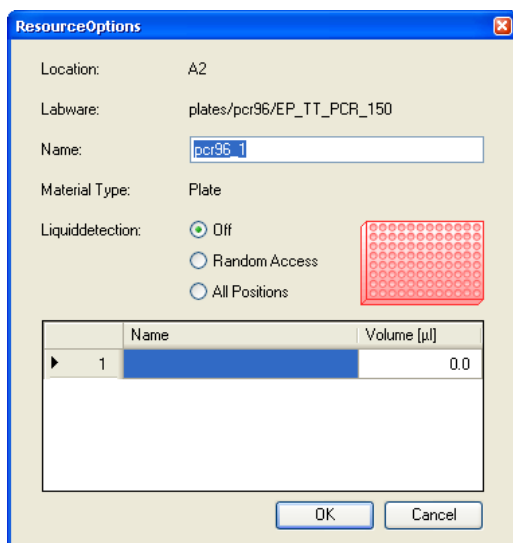

The worktable is now equipped with the necessary labware for this method.

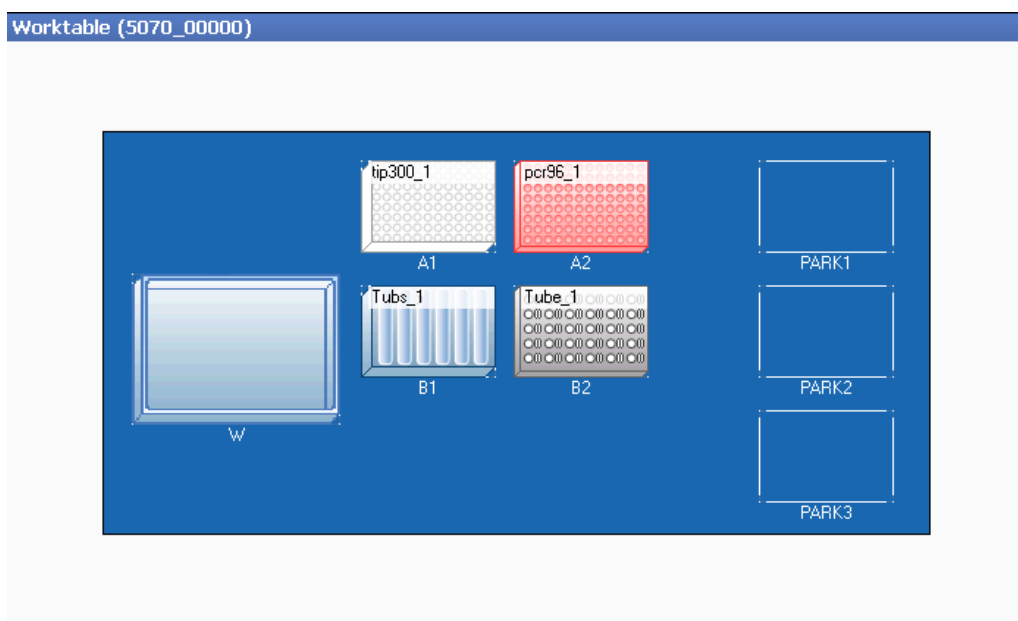

14. To save the method with this worktable assignment, click the *Save* icon, or select *File - Save* from the main menu, or right-click on the method name and select *Save* from the context menu.

For more detailed information on supplying the worktable, please refer to the detailed description (see *Worktable tab - equip the worktable on p. 58*).

## Defining the procedure

1. In the Work tab, select the Procedure tab to define the sequence of commands to be carried out when you run the method.
2. Double-click on the **Number of Samples** icon in the Commands section of the Procedure tab to add a Number of Samples command to the procedure.



3. In the Parameter section, activate the checkbox **Fix Number of Samples** and enter 8 as the fixed number of samples.

Number of Samples

Fix Number of Samples:

Number of Samples:

Max Number of Samples:

Comment:

4. Double-click on the **Reagent Transfer** icon in the Commands section of the Procedure tab to append it to the program, or click on the icon, drag the command upwards and drop it in the next program position.



5. In the Parameter section, make the following settings for the Reagent Transfer command:
  - **Pipet. Tool:** select TM\_300\_8.
  - **Volume:** enter 100 µL.
  - Select **Multidispense**.

- In the Source list, select the reservoir rack (*Tubs\_1*) as source. In the Destination list, select the PCR plate (*pcr96\_1*) as the destination.

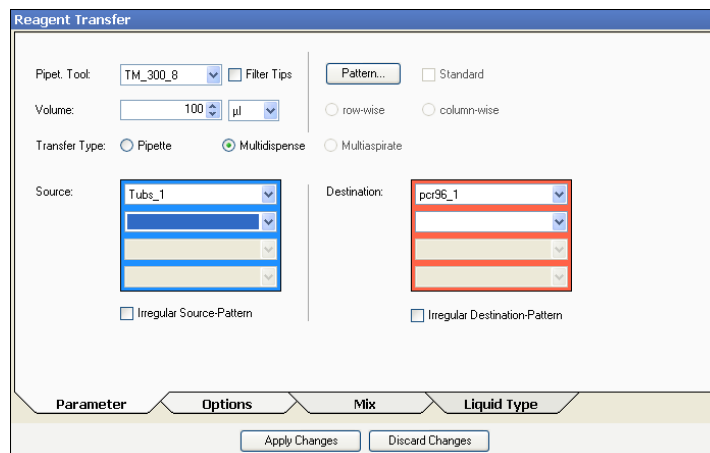

- To define the pattern for the Reagent Transfer, click the *Pattern* button. The Pattern window opens. The source labware is shown on the left, highlighted in blue. The destination labware is shown on the right, highlighted in red.
- In the source labware, click on the position with the filled 30 mL reservoir. In the destination labware, click on the first two columns (A1 and A2).

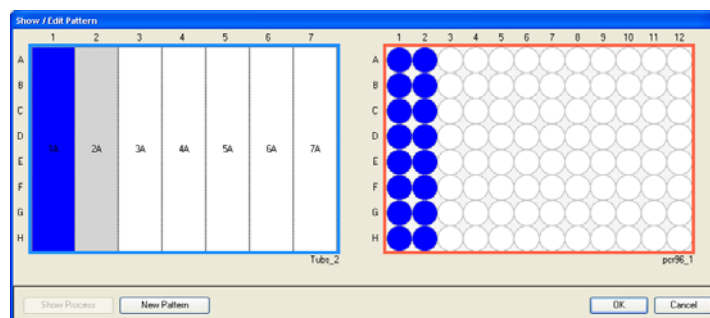

- Click *OK* to confirm the pattern and close the pattern window.
- Click on the **Options** tab in the parameter section for the Reagent Transfer command. Under **Change Tips**, select the option **when command finished**.

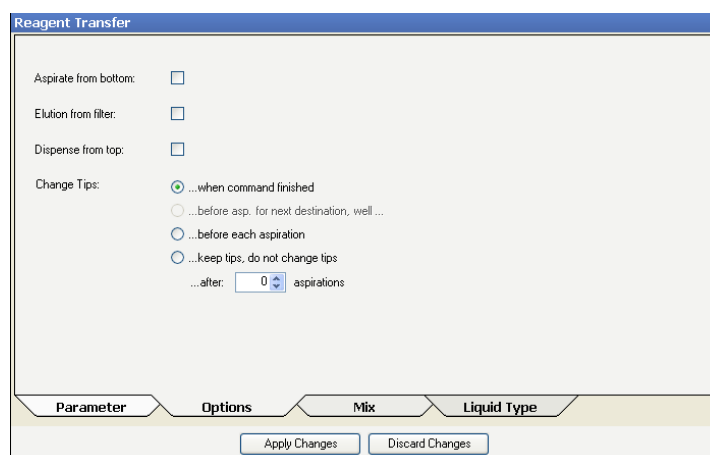

- Double-click on the **Sample Transfer** icon in the Commands section of the Procedure tab to append it to the program, or click on the icon, drag the command upwards and drop it in the next program position.



- In the Parameter section, make the following settings for the Sample Transfer command:
  - **Pipet. Tool:** select TS\_300.
  - **Volume:** enter 50 µL.
  - Select **Pipette**.

- In the Source list, select the Reservoir Rack (*Tube\_1*) as source, and activate the option **Irregular Source-Pattern**. By selecting this option, you can define an irregular pattern for the samples provided. In the Destination list, select the PCR plate (*pcr96\_1*) as the destination.

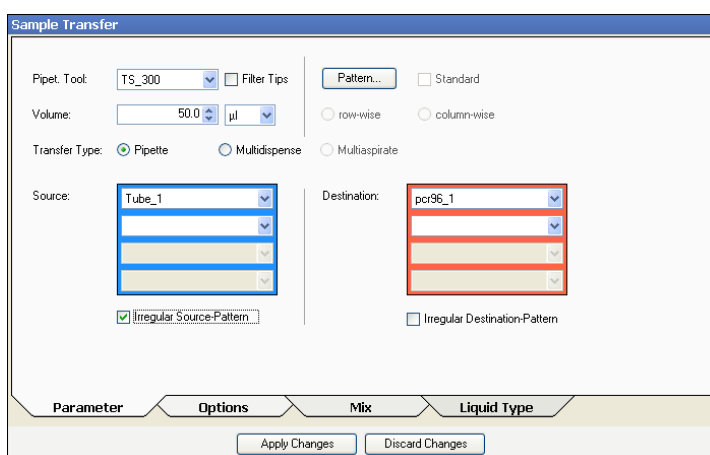

- To define the pattern for the Sample Transfer, click the *Pattern* button.

- In the source labware, click on all positions containing sample tubes. After each individual entry, switch between source and destination.

- Switch between source and destination to select the remaining (irregular) source positions and the (regular) destination positions. As the option **Irregular Pattern** is active only for the source, the individual wells of the destination can only be selected in the regular pattern.

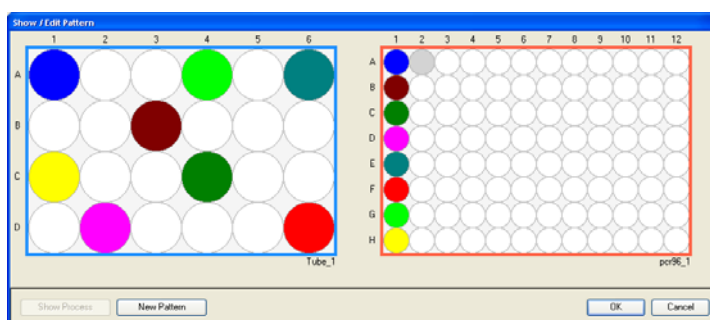

- Click *OK* to confirm the pattern and close the pattern window.

- Click on the Options tab in the parameter section. Under **Change Tips**, select the option **before asp. for next destination, well ....**

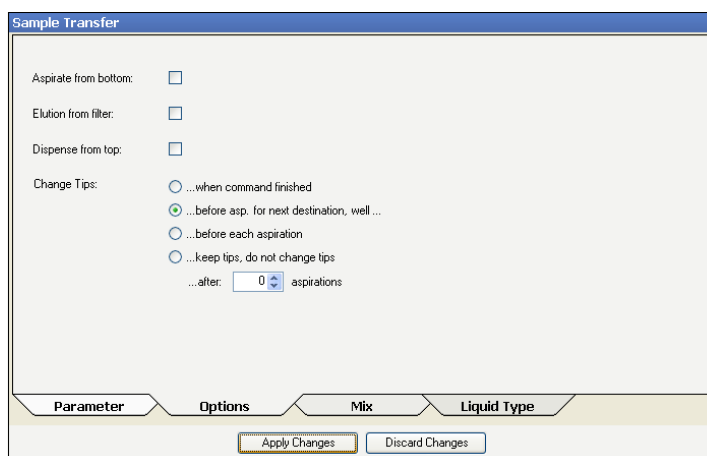

- To save the method with this procedure, click the *Save* icon, or select *File - Save* from the main menu, or right-click on the method name and select *Save* from the context menu. For more detailed information on defining a procedure, please refer to the detailed description (see *Procedure tab - defining a procedure on p. 63*).

### Checking and saving the method

- To check the parameter settings of the current method, select *Edit - Check Method* from the main menu.  
A message window opens to inform you if a parameter error was found. Correct the error and repeat the check until all errors have been corrected.
- To save the method, click the *Save* icon, or select *File - Save* from the main menu, or right-click on the method name and select *Save* from the context menu.

### 5.2.4 Starting the method

- Change to the Run tab and activate the option *Filter Devicelist* to display only devices which are online and which fit the method.

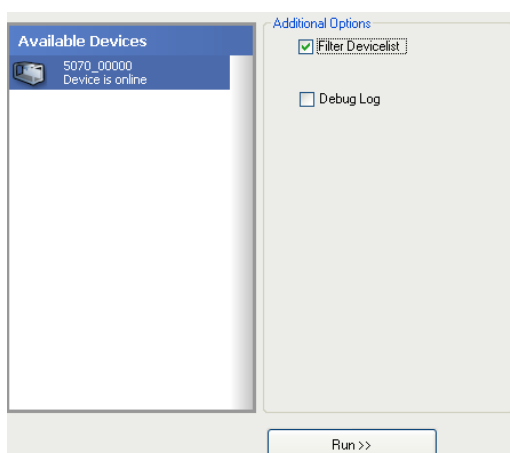

- Select the device you want to use and click *Run*.  
The method is loaded on the selected device.  
As the Number of Samples command in the procedure specifies a variable number of samples, you must enter the number of samples for this run manually.
- Enter the number of samples and click *OK*.

4. Check the supply of the worktable. To edit labware-specific settings for level sensor and volumes, double-click the labware in the Worktable section of the Run tab.
5. Specify level sensor settings for this method run.
  - **Levels:** check the liquid levels according to the settings defined for the individual labware items.
  - **Tips:** check the type and quantity of tips in the tip rack.
  - **Locations:** check that the labware is positioned correctly on the worktable, as specified in the method.

Click *Run*.

A volume query appears for the MTP 96 plate, as *Off* was previously set for liquid detection.

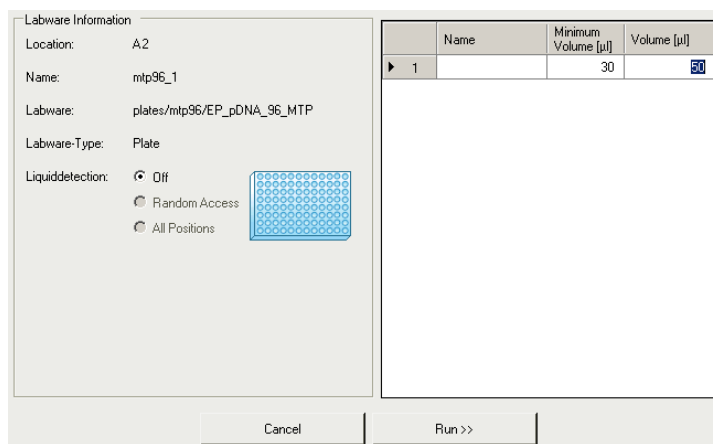

6. Enter 50 µL as the volume, and click *Run*.  
The method starts, and the display switches to the Control tab. The progress and current status of the method is displayed. A message appears when the method run is complete.
7. To abort the method before it is complete, click the *Stop* icon in the Control tab. The method stops. Then click the *Abort* icon to abort the method.

## 6 Troubleshooting

### 6.1 Error search

If a method does not start running after Start, check the following points. Note that the Labware on the worktable must match the method.

- Is plate or rack correctly inserted and not the wrong way round?
- Is a height adapter with the correct height being used?
- Are all the plates, racks, tips, tubs etc. shown in the display present on the worktable of the instrument?
- Are all tubes and tubs open?
- Are the tip racks filled with enough tips and have the lids been taken off the tip racks?
- Is the lid of Safe-Lock tubes correctly positioned?
- Are all the locations on the worktable of the instrument indicated as *empty* in the display really empty?
- Is the waste container empty?

If there is a bag in the waste container: check that bag has a clean finish and check its clamping ring. The bag must be inserted so that an adequate number of tips can be contained. Furthermore, the bag may not project into locations B1 or A1. The clamping ring must finish flush.

- Is the correct dispensing tool inserted and is it undamaged?
- Are the necessary filling quantities for the source present?
- Are racks or plates subsequently required for the parking positions ready and has their volume been entered?



Barcode

For an epMotion with barcode reader:

- Is the barcode reader correctly connected?
- Was the correct barcode ID scanned?
- If barcode ID tracking ensured by the commands of the method?

### 6.2 General errors

#### 6.2.1 Read error of the optical sensor

Symptom/message	Cause	Remedy
Read error of the optical sensor in detecting labware	Plates such as MTP, DWP, PCR etc. are not level on the worktable surface or have been inserted inverted.	▶ Check that the labware has been correctly inserted into the location.
Read error of the optical sensor in detecting labware	The plastic plate is not detected. The cause might be a minor unevenness in the the plastic surface. Such unevenness is usually not visible.	▶ Wipe a moist cloth several times over the detection range of the optical sensor on the labware. ▶ Repeat the <i>Location</i> detection with a still lightly moist surface.
Read error of the optical sensor in detecting the pipette tips	Problem when detecting pipette tips.	▶ Turn the tip rack by 180°.
Read error of the optical sensor in detecting the fluid level	Fluid surface not level (strong meniscus formation).	Carefully tap the rack or plate on the table until the surface is level.
Read error of the optical sensor in detecting the fluid level	Blisters or foam at the surface.	Remove the blisters/foam.



The detection of the location in plates takes place at the right margin.  
In case of a "Location" read error of the optical sensor a dialog with the appropriate correction option is shown.

### 6.2.2 Dispensing error

In case of doubts about the correctness of the dispensing note the information in the appendix and all information on the selected liquid type.

### 6.3 Error messages



All software error messages are issued in English. This also applies if "German" is selected in the language setting for the software.



Should you require service, contact your official dealer for Eppendorf products or our sales office. You can find the addresses of our dealers on our website [www.eppendorf.com](http://www.eppendorf.com). The addresses of our sales offices are listed on the penultimate page of these Instructions for Use.

Code	Symptom/message	Cause	Remedy
0x0600	Tool did not find home	<ul style="list-style-type: none"> <li>• Home position for the tool is not found.</li> <li>• No tool inserted.</li> <li>• Tool damaged.</li> <li>• PCB damaged.</li> <li>• Switch damaged.</li> <li>• Tool file does not correspond with tool.</li> </ul>	<ul style="list-style-type: none"> <li>▶ Insert tool.</li> <li>▶ Check tool.</li> <li>▶ Reboot and try again.</li> <li>▶ If error occurs again: Call local Eppendorf Service.</li> </ul>
0x0601	Hardware error Dosing device: final position always found	Dosing motor: home switch always on.	▶ Call local Eppendorf Service.
0x0607	Hardware error Dosing device: steps lost	Dosing motor: steps lost.	▶ Call local Eppendorf Service.
0x060D	Hardware error Dosing device: steps lost	Dosing motor: steps lost.	▶ Call local Eppendorf Service.
0x060E	Tool did not find home	Tool home position is not found.	<ul style="list-style-type: none"> <li>▶ No tool deployed.</li> <li>▶ Tool defective.</li> <li>▶ PCB defective.</li> <li>▶ Switch defective.</li> <li>▶ Tool file and tool do not correspond.</li> </ul>
0x060F	Hardware error Dosing device: final position not found	Dosing motor: home switch not reached again.	▶ Call local Eppendorf Service.
0x0709	The named file is invalid for updating the device.	The file contains incorrect control information. File may be damaged while copying.	▶ New file is essential. Call local Eppendorf Service.
0x070A	The cyclic redundancy check for the named file failed.	The file contains incorrect control information. File may be damaged while copying.	▶ New file is essential. Call local Eppendorf Service.

Code	Symptom/message	Cause	Remedy
0x070B	Error Flash Loader	The file contains incorrect control information. File may be damaged while copying.	▶ New file is essential. Call local Eppendorf Service.
0x0863	Thermomixer missing	Hardware error The thermomixer is not configured or is damaged.	Shut down and switch off the instrument; if error re-occurs after switching on: Call Eppendorf Service
0x0864	Thermomixer is not configured	Hardware error The thermomixer is not configured or is damaged.	Shut down and switch off the instrument; if error re-occurs after switching on: Call Eppendorf Service
0x0980	Thermomixer does not react	Hardware error The thermomixer does not respond to the system.	Shut down and switch off the instrument; if error re-occurs after switching on: Call Eppendorf Service
0x0954; 0x0964; 0x0974		The control time on a temperature was exceeded.	▶ Call local Eppendorf Service.
0x0B04	Not enough space on medium	Not enough space on medium to allocate buffer for file or directory.	▶ Make sure that there is enough space on medium. ▶ Make sure that there is enough space on medium. Either delete some files or replace the medium.
0x0B05	Error reading file path	<ul style="list-style-type: none"> <li>Internal file path conversion error.</li> </ul>	▶ Make sure that the file name and path is valid.
0x0B08	Invalid path or filename	Filename or path is invalid.	▶ Make sure that the file name and path is valid.
0x0B09	Too many files/directories open	The number of allowed open files and directories has reached its maximum.	▶ Close other open files.
0x0B0A	File or directory does not exist	File or directory does not exist.	▶ Make sure that the file name and path is valid.
0x0B0B	No name or directory found	File path is empty.	▶ Reboot and try again.
0x0B0C	Could not open file	Filename pointer/ID invalid	▶ Reboot and try again.
0x0B0D	Error opening file or directory.	File may be in use.	▶ Make sure that the file is not in use and try to open it again.
0x0B0E	Error closing file or directory.	File may be in use.	▶ Make sure that the file is not in use and try to close it again.
0x0B0F	Error opening/closing file or directory.	File may be in use.	▶ Make sure that the file is not in use and try to open/close it again.
0x0B10	Error opening file or directory.	<ul style="list-style-type: none"> <li>File may be in use, or</li> <li>file is damaged.</li> </ul>	▶ Make sure that the file is not in use and try to open it again. If error occurs again: ▶ Call local Eppendorf Service.
0x0B11	Error closing file or directory.	File may be in use.	▶ Make sure that the file is not in use and try to close it again.

Code	Symptom/message	Cause	Remedy
0x0B14	File is in use and cannot be accessed	<ul style="list-style-type: none"> <li>• Logfile is opened for viewing while the instrument tries to write into the file.</li> <li>• System errors.</li> </ul>	<ul style="list-style-type: none"> <li>▶ Close file; or:</li> <li>▶ Call local Eppendorf Service.</li> </ul>
0x0B15	Error opening file or directory.	File may be in use.	▶ Make sure that the file is not in use and try to open it again.
0x0B16	Error closing file or directory.	File may be in use.	▶ Make sure that the file is not in use and try to close it again.
0x0B17	Error opening file or directory.	File may be in use.	▶ Make sure that the file is not in use and try to open it again.
0x0B18	Error opening file or directory.	File may be in use.	▶ Make sure that the file is not in use and try to open it again.
0x0B40	Error opening file or directory.	File may be in use. Error opening file. Does it exist?	▶ Make sure that the file is not in use or does the file exist and try to open it again.
0x0B41	Error closing file or directory.	File may be in use.	▶ Make sure that the file is not in use and try to close it again.
0x0B42	Error reading file	File may be corrupted.	▶ Use Checkdisk
0x0B43	Error writing file	File may be corrupted.	▶ Use Checkdisk.
0x0B44	Illegal file length. Trying to read or write beyond file.	File may be corrupted.	▶ Use Checkdisk.
0x0B45	Error deleting file	File may be corrupted.	▶ Use Checkdisk.
0x0B46	Error renaming a file	File may be corrupted.	▶ Use Checkdisk.
0x0B48	Error creating file. File exists	File name has been edited that already exists.	▶ Use another name for the new file.
0x0B80	Error creating directory. Directory exists!	See error message.	▶ Use another name for the new file.
0x0B81	Error creating directory. Directory exists!	See error message.	▶ Use another name for the new file.
0x0B82	Error getting file entries	Some files may be deleted, or directory is corrupt.	▶ Use Checkdisk.
0x0B84	Error getting directory entries	Some files may be deleted, or directory is corrupt.	▶ Use Checkdisk.
0x0B85	Error listing files. Number of files in directory is not the same anymore.	Some files may be deleted, or directory is corrupt.	▶ Use Checkdisk.
0x0B88	Error deleting directory.	Some files may be deleted, or directory is corrupt.	▶ Use Checkdisk.
0x0BC0	Format aborted by user	See error message.	▶ Error message was an information for the user that he had aborted.
0x0C01	Volume too large for this tool	<p>Volume to be dispensed is too large for the selected tool. Possible causes:</p> <ul style="list-style-type: none"> <li>• Errors in tool files.</li> <li>• Errors in liquid type files.</li> </ul>	▶ Call local Eppendorf Application Support.

Code	Symptom/message	Cause	Remedy
0x0C02	Volume too small for this tool	Volume to be dispensed is too small for the selected tool. Possible causes: <ul style="list-style-type: none"> <li>• Errors in tool files.</li> <li>• Errors in liquid type files.</li> </ul>	▶ Call local Eppendorf Application.
0x0C08	Tool dimension unknown	Tool dimension values unknown. Labware outdated or corrupt.	▶ Make sure all labware is of the latest version.
0x1206 to 0x1210	No message text	Internal error.	▶ Call local Eppendorf Service.
0x120A	Program aborted by user	User pressed the <i>Abort</i> button during program run.	▶ Error message was an information for the user that he had aborted.
0x1221	The hood was opened while the program was stopped	See error message.	▶ Close hood.
0x1222	Transfer allowance was prematurely deactivated during program initialization	See error message.	▶ Start program again.
0x1223	Internal critical error	Hardware error. Restart of program impossible.	▶ Call local Eppendorf Service.
0x1249	Step time in program is too high.	Illegal value has been detected in program.	▶ Check step time in program and start program again.
0x124A	Step time in program is too low.	Illegal value has been detected in program.	▶ Check step time in program and start program again.
0x124B	Time increment in program is too high.	Illegal value has been detected in program.	▶ Check time increment in program and start program again.
0x124C	Time increment in program is too low.	Illegal value has been detected in program.	▶ Check time increment in program and start program again.
0x1259	Error while choosing rack or tube at program start	Neither rack or tube were selected.	▶ Restart program and be sure to select either rack or tube.
0x1289	Carrier: final position in x not found	<ul style="list-style-type: none"> <li>• Problems in carrier movement in x-axis (sluggish movement or no movement at all).</li> <li>• Light barrier for carrier in x-axis defective.</li> </ul>	▶ Call local Eppendorf Service.
0x128A	Carrier: final position in x always found	<ul style="list-style-type: none"> <li>• Problems in carrier movement in x-axis (sluggish movement or no movement at all).</li> <li>• Light barrier for carrier in x-axis defective.</li> </ul>	▶ Call local Eppendorf Service.
0x128B	Carrier: steps lost in x	<ul style="list-style-type: none"> <li>• Carrier was touched by the user.</li> <li>• Sluggishness in carrier movement in x-axis.</li> </ul>	▶ Shut down and switch off the instrument; if error reoccurs after switching on and restarting a method run: ▶ Call local Eppendorf Service.

Code	Symptom/message	Cause	Remedy
0x128C	Carrier: final position in y not found	<ul style="list-style-type: none"> <li>• Problems in carrier movement in y-axis (sluggish movement or no movement at all).</li> <li>• Light barrier for carrier in y-axis defective.</li> </ul>	<ul style="list-style-type: none"> <li>▶ Call Eppendorf Service.</li> </ul>
0x128D	Carrier: final position in y always found	<ul style="list-style-type: none"> <li>• Problems in carrier movement in y-axis (sluggish movement or no movement at all).</li> <li>• Light barrier for carrier in y-axis defective.</li> </ul>	<ul style="list-style-type: none"> <li>▶ Call local Eppendorf Service.</li> </ul>
0x128E	Carrier: steps lost in y	<ul style="list-style-type: none"> <li>• Carrier was touched by the user</li> <li>• Sluggishness in carrier movement in y-axis</li> </ul>	<ul style="list-style-type: none"> <li>▶ Shut down and switch off the instrument; if error reoccurs after switching on and restarting a method run:</li> <li>▶ Call local Eppendorf Service.</li> </ul>
0x128F	Carrier: final position 1 in z not found	<ul style="list-style-type: none"> <li>• Problems in carrier movement in z-axis (sluggish movement or no movement at all).</li> <li>• Light barrier for carrier in x-axis defective.</li> </ul>	<ul style="list-style-type: none"> <li>▶ Call local Eppendorf Service.</li> </ul>
0x1290	Carrier: final position 1 in z always found	<ul style="list-style-type: none"> <li>• Problems in carrier movement in z-axis (sluggish movement or no movement at all).</li> <li>• Light barrier for carrier in z-axis defective.</li> </ul>	<ul style="list-style-type: none"> <li>▶ Call local Eppendorf Service.</li> </ul>
0x1291	Carrier: final position 2 in z not found	<ul style="list-style-type: none"> <li>• Problems in carrier movement in z-axis (sluggish movement or no movement at all).</li> <li>• Light barrier for carrier in x-axis defective.</li> </ul>	<ul style="list-style-type: none"> <li>▶ Call local Eppendorf Service.</li> </ul>
0x1292	Carrier: final position 2 in z always found	<ul style="list-style-type: none"> <li>• Problems in carrier movement in z-axis (sluggish movement or no movement at all).</li> <li>• Light barrier for carrier in z-axis defective.</li> </ul>	<ul style="list-style-type: none"> <li>▶ Call local Eppendorf Service.</li> </ul>
0x1293	Carrier: final position in z wrong	<ul style="list-style-type: none"> <li>• Problems in carrier movement in z-axis (sluggish movement or no movement at all).</li> <li>• Light barrier for carrier in z-axis defective.</li> </ul>	<ul style="list-style-type: none"> <li>▶ Call local Eppendorf Service.</li> </ul>
0x1294	Carrier: steps lost in z	<ul style="list-style-type: none"> <li>• Carrier was touched by the user.</li> <li>• Sluggishness in carrier movement in z-axis.</li> </ul>	<ul style="list-style-type: none"> <li>▶ Shut down and switch off the instrument; if error reoccurs after switching on and restarting a method run:</li> <li>▶ Call local Eppendorf Service.</li> </ul>

Code	Symptom/message	Cause	Remedy
0x1295	Carrier: steps lost in z before picking up tip	<ul style="list-style-type: none"> <li>• Tip was still on pipette tool when tool started to pick up a new tip.</li> <li>• Tip rack not placed correctly on the worktable.</li> <li>• Mechanical problems of carrier.</li> </ul>	<ul style="list-style-type: none"> <li>▶ Remove tips from tools.</li> <li>▶ Place tip rack correctly and plane on the worktable.</li> </ul> In other cases: <ul style="list-style-type: none"> <li>▶ Call local Eppendorf Service.</li> </ul>
0x1296	Maximum number of tool cycles exceeded	See error message.	<ul style="list-style-type: none"> <li>▶ Use a new tool.</li> </ul>
0x1297	Danger of collision	When running the programmed application, the tool carrier system will touch racks or other labware on the worktable; e.g., during pipetting the optical sensor may touch a long tube on the adjacent position; possible reasons: <ul style="list-style-type: none"> <li>• A low plate (microplate) is located next to a high tube rack.</li> <li>• The 50 µL or 300 µL tip is programmed to move almost to the bottom of a very long tube with another long tube in the adjacent position.</li> </ul>	<ul style="list-style-type: none"> <li>▶ Program the labware on the worktable in a way that high and low labware are not adjacent.</li> <li>▶ Program the labware in a way that the 30 µL or 300 µL tip does not have to move deeply into a long vessel.</li> <li>▶ If possible: use higher volumes in the long vessels.</li> <li>▶ If possible: use longer tips for the long vessels.</li> </ul>
0x1298	Tool not calibrated	The actual tool is not calibrated.	Calibrate the actual tool.
0x1299	Invalid number of samples	Value for Number of Samples not permissible.	<ul style="list-style-type: none"> <li>▶ Insert an admissible value for Number of Samples.</li> </ul>
0x129A	Tip too small	<i>Reagent Transfer</i> : Used tip is too small.	<ul style="list-style-type: none"> <li>▶ Use a larger tip.</li> </ul>
0x129B	Source vessel too small	<i>Reagent Transfer</i> : Used source vessel is too small.	<ul style="list-style-type: none"> <li>▶ Use a larger vessel.</li> </ul>
0x12D0	Parameter conflict: Elution volume too large for this tool	Sample transfer with <i>elution from filter</i> option: Volume to be aspirated is too large for the tip used.	<ul style="list-style-type: none"> <li>▶ Select a tip large enough for picking up the liquid as well as the additional volume of air to be aspirated when using this option.</li> </ul>
0x12D1	Parameter conflict: Elution volume too large for destination tube or well	Option <i>elution from filter</i> : volume is too large for the vessel used.	<ul style="list-style-type: none"> <li>▶ Select a tool large enough when using this option.</li> </ul>
0x12E0	Error in system configuration	Error in system configuration.	Correct system configuration.
0x12E1	Parameter conflict: Prewetting not possible when aspirate from bottom is selected	See error message.	<ul style="list-style-type: none"> <li>▶ Change application.</li> </ul>
0x12E2	Parameter conflict: Prewetting not possible when dispense from top is selected	See error message.	<ul style="list-style-type: none"> <li>▶ Change application.</li> </ul>

Code	Symptom/message	Cause	Remedy
0x12E3	Parameter conflict: Prewetting not possible when elution from filter is selected	A liquid type using a prewetting step (e.g., ethanol 98%) cannot be used in combination with the <i>elution from filter</i> parameter in a <i>sample transfer</i> command.	▶ Change application.
0x12E6	Level too high	The liquid level would be higher than the vessel after dispensing.	▶ Adjust the liquid to be dispensed to the vessel.
0x12E7	Opening the hood is not allowed when putting down tool.  Switch off power, then switch on again to restart method.	See error message.	▶ See error message.
0x12E9	Tool not locked	This can only happen with the 5070. The tool lock is not properly closed.	▶ Close tool lock.
0x12F1	No communication with thermomixer	Hardware error The thermomixer may be damaged.	Shut down and switch off the instrument; if error re-occurs after switching on: Call Eppendorf Service
0x12F3	Thermomixer is too hot for labware (temperature command in this method)	The temperature unit of the thermomixer is too hot for the selected labware	Choose a lower temperature
0x12F4	The thermomixer is too hot for labware (temperature command in previous method)	The temperature unit of the thermomixer is too hot for the selected labware	Choose a lower temperature
0x12F7	Waiting for thermomixer	The procedure is waiting for the thermomixer.	Wait until thermomixer function has ended
0x12F8	The selected mixing speed is not possible with this labware	The mixing speed is not allowed for the selected labware	Select another labware or mixing speed
0x1500	Too big vessel index in location: ...	A tube is to be accessed for which the index is greater than the number of tubes on the plate/rack/holder.	▶ Error during creation of the application.
0x1504	<rack name> is not accessible for tools in location ...	Rack is a lower part of a labware stack; therefore, the tool has no access.	▶ Change application so that the rack is accessible.
0x1509	Liquid volume too large for vessel in location:...	Total volume supplied in a source vessel is larger than needed or larger than vessel.	<ul style="list-style-type: none"> <li>▶ Provide less volume in the vessel.</li> <li>▶ Change application.</li> <li>▶ When verifying the total volume needed for the source or destination, take into account additional aspirated volume in case of multidispense mode(see <i>Important volume terms for tubes and wells</i> on p. 19).</li> </ul> epMotion 5070 only: <ul style="list-style-type: none"> <li>▶ Set <i>liquid detection</i> to <i>off</i> for racks that are on park positions at the beginning of the procedure.</li> </ul>

Code	Symptom/message	Cause	Remedy
0x150A	Liquid volume too low for vessel in location: ...	Total volume supplied by the user in a source vessel is smaller than needed for a sample transfer, reagent transfer or mix command (total volume = volume to be aspirated + remaining volume for this vessel + (in case of multidispense mode:) additional aspirated volume.	<ul style="list-style-type: none"> <li>▶ Calculate the total volume for the source or destination vessel and select a suitable vessel. Regarding additional aspirated volume in case of multidispense mode, refer to manual (see <i>Important volume terms for tubes and wells on p. 19</i>).</li> <li>▶ Consider that the software may calculate higher remaining volumes in some cases to avoid crashes.</li> <li>▶ Set <i>liquid detection</i> to <i>off</i> for racks that are on park positions at the beginning of the procedure.</li> </ul>
0x150B	Optical sensor: Liquid volume too low in location: ...	See above (error 0x150A).	▶ See above (error 0x150A).
0x150D	Optical sensor: Plate could not be found in location: ... Optical sensor: Rack could not be found in location: ...	The rack programmed for this location could not be found by the optical sensor; possible causes: <ul style="list-style-type: none"> <li>• Rack not placed onto location (wrong rack code or wrong rack height).</li> <li>• Rack in wrong orientation.</li> <li>• Problems related to the optical sensor function.</li> </ul>	<ul style="list-style-type: none"> <li>▶ Place the rack onto the locations as edited in the corresponding application; or:</li> <li>▶ Make sure that the rack is placed plane on the worktable surface; or:</li> <li>▶ Rotate rack 180° (front to back) and place it back onto the worktable location; or:</li> <li>▶ Call local Eppendorf Service.</li> </ul>
0x150E	Optical sensor: Tips could not be found in location ...	The tip rack programmed for this location could not be found by the optical sensor; possible causes: <ul style="list-style-type: none"> <li>• Tip rack not placed onto location.</li> <li>• Problems related to the optical sensor function.</li> </ul>	<ul style="list-style-type: none"> <li>▶ Place the tip rack onto the locations as edited in the corresponding application; or:</li> <li>▶ Call local Eppendorf Service.</li> </ul>
0x1510	Optical sensor: Nothing could be found in location:	See error message.	<ul style="list-style-type: none"> <li>▶ Place the labware programmed for this location on the worktable.</li> </ul> If error occurs again: <ul style="list-style-type: none"> <li>▶ Call local Eppendorf Service.</li> </ul>
0x1512	Tip type ... is not placed on the worktable	Tips that are needed according to the application are not available on the worktable.	<ul style="list-style-type: none"> <li>▶ Place the tip tray programmed for this location on the worktable.</li> </ul> If error occurs again: <ul style="list-style-type: none"> <li>▶ Call local Eppendorf Service.</li> </ul>
0x1513	Position is out of range	The position to be addressed by the tool carrier is outside of its available range. Possible cause: Rack in park position is programmed to be addressed by the dispensing tool.	<ul style="list-style-type: none"> <li>▶ Change application.</li> </ul> If error occurs again: <ul style="list-style-type: none"> <li>▶ Call local Eppendorf Service.</li> </ul>
0x1514	Optical sensor: Rack in wrong orientation in location ...	The tub holder has been placed onto the worktable in the wrong direction.	▶ Rotate tub holder 180° and place it back onto the worktable; restart the application.

Code	Symptom/message	Cause	Remedy
0x1515	Tool cannot be used for rack in location ...	Distance between tip cones of the liquid handling tool does not match the distance between vessels (e.g., 24 tubes - rack does not fit the 8-channel tool).	<ul style="list-style-type: none"> <li>▶ Change application.</li> </ul>
0x1516	No vessel in location: ...	Vessels that are needed according to the application are not available on the worktable (vessel/rack combination).	<ul style="list-style-type: none"> <li>▶ Place the vessel/rack combination programmed for this location on the worktable.</li> </ul> <p>If error occurs again:</p> <ul style="list-style-type: none"> <li>▶ Call local Eppendorf Service.</li> </ul>
0x1519	Tip is too thick for vessel in location: ...	Diameter of the destination vessel is too small for the tip when dispensing the liquid.	<ul style="list-style-type: none"> <li>▶ Select other tips or vessels in the application.</li> <li>▶ Select <i>dispense from top</i> in the options of the liquid handling command.</li> </ul>
0x151A	Optical sensor: There is a cap on vessel in location: ...	The optical sensor has detected a cap on a vessel when trying to detect a liquid level.	<ul style="list-style-type: none"> <li>▶ Remove the cap from the vessel and start the run again.</li> </ul>
0x151B	Optical sensor: There is a wrong vessel in location: ...	Relates to vessels that are equipped with a readable code (e.g. Eppendorf tubs): The rack programmed for this location could not be found by the optical sensor; possible causes: <ul style="list-style-type: none"> <li>• Wrong vessel.</li> <li>• Problems related to the optical sensor function.</li> </ul>	<ul style="list-style-type: none"> <li>▶ Place the vessel onto the location as edited in the corresponding application; or</li> <li>▶ Call local Eppendorf Application Support.</li> </ul>
0x151C	Optical sensor: Vessel too high for level detection in location: ...	Level detection for very high vessels is not possible.	<ul style="list-style-type: none"> <li>▶ Switch off the level detection for this vessel.</li> <li>▶ Use level detection only for vessel/ rack equipment with a total height below 103 mm.</li> </ul>
0x151E	Detected volume is out of detection range ...	Normally a system/hardware error (malfunction of the optical sensor); but may also be caused by filling a vessel up to the total vessel height.	<ul style="list-style-type: none"> <li>▶ Do not fill vessels above the specified maximum filling volume.</li> </ul> <p>In other cases:</p> <ul style="list-style-type: none"> <li>▶ Call local Eppendorf Service.</li> </ul>
0x151F	Labware stack too high in location: Maximum pieces which may be piled:	A maximum of 5 racks can be stacked in a location. Placing more than 5 racks in a location.	<ul style="list-style-type: none"> <li>▶ Do not stack more than 5 racks in a location.</li> </ul>
0x1526	No free position for deposition of tool available	When trying to deposit the dispensing tool after use the tool holder did not find a free position for the tool.	<ul style="list-style-type: none"> <li>▶ Clear at least one position on the worktable to accept a dispensing tool.</li> </ul>
0x1528	Method program may not use more than four dispensing tools	See error message.	<ul style="list-style-type: none"> <li>▶ If more than 4 dispensing tools are needed, divide the application into two applications that use no more than 4 dispensing tools.</li> </ul>

Code	Symptom/message	Cause	Remedy
0x152D	Tip too short Select other tips or vessels in the method.	Tip does not reach the liquid level at the beginning or during the course of the liquid handling command.	<ul style="list-style-type: none"> <li>▶ Select other tips or vessels in the application.</li> </ul>
0x1581	Optical sensor: Liquid level could not be detected in location: ...	Error in level detection.	<ul style="list-style-type: none"> <li>▶ Repeat measurement.</li> </ul>
0x1700	Liquid volume too low for vessel in location: ...	Total volume supplied by the user in a source vessel is smaller than needed for a sample transfer, reagent transfer or mix command (total volume = volume to be aspirated + remaining volume for this vessel + (in case of multidispense mode:) additional aspirated volume.	<ul style="list-style-type: none"> <li>▶ Calculate the total volume for the source or destination vessel and select a suitable vessel. Regarding additional aspirated volume in case of multidispense mode, refer to manual (see <i>Important volume terms for tubes and wells on p. 19</i>).</li> <li>▶ Consider that the software may calculate higher remaining volumes in some cases to avoid crashes.</li> <li>▶ Set <i>liquid detection</i> to <i>off</i> for racks that are on park positions at the beginning of the procedure.</li> </ul>
0x1701	Liquid volume too large for vessel in location:...	Total volume supplied in a source vessel is larger than needed or larger than vessel.	<ul style="list-style-type: none"> <li>▶ Provide less volume in the vessel.</li> <li>▶ Change application.</li> <li>▶ When verifying the total volume needed for the source or destination, take into account additional aspirated volume in case of multidispense mode(see <i>Important volume terms for tubes and wells on p. 19</i>).</li> </ul> <p>epMotion 5070 only:</p> <ul style="list-style-type: none"> <li>▶ Set <i>liquid detection</i> to <i>off</i> for racks that are on park positions at the beginning of the procedure.</li> </ul>
0x1900	Program error/system error	Internal program error.	<ul style="list-style-type: none"> <li>▶ Restart application run or restart system.</li> </ul> <p>If error occurs again:</p> <ul style="list-style-type: none"> <li>▶ Call local Eppendorf Service.</li> </ul>
0x1901	Loading error	File damaged.	<ul style="list-style-type: none"> <li>▶ Call local Eppendorf Service.</li> </ul>
0x1902	Loading error	File damaged.	<ul style="list-style-type: none"> <li>▶ Call local Eppendorf Service.</li> </ul>
0x1903	Loading error	File damaged.	<ul style="list-style-type: none"> <li>▶ Call local Eppendorf Service.</li> </ul>
0x1904	The following labware has been deleted: ...	Edit mode: The worktable was changed after an application had been programmed; thus, the labware defined in a command is no longer available.	<ul style="list-style-type: none"> <li>▶ Change the <i>source</i> or <i>destination</i> in the parameter of the respective command in accordance to match the worktable. In this case the pattern also has to be re-edited;</li> <li>▶ The labware has to be reprogrammed in the worktable.</li> </ul>
0x1905	Loading error	File damaged.	<ul style="list-style-type: none"> <li>▶ Call local Eppendorf Service.</li> </ul>

Code	Symptom/message	Cause	Remedy
0x1906	Loading error	File damaged.	▶ Call local Eppendorf Service.
0x1907	Loading error	File damaged.	▶ Call local Eppendorf Service.
0x1908	The method was written with a newer program structure. You must update your software if you want to edit this method	See Error message.	▶ Update your software, or: ▶ Call local Eppendorf Service.
0x1909	Loading error	File damaged.	▶ Call local Eppendorf Service.
0x190A	Program error/system error	Internal program error.	▶ Restart application run or restart system. If error occurs again: ▶ Call local Eppendorf Service.
0x190B	Program error/system error	Internal program error.	▶ Restart application run or restart system. If error occurs again: ▶ Call local Eppendorf Service.
0x190C	Program error/system error	Internal program error.	▶ Restart application run or restart system. If error occurs again: ▶ Call local Eppendorf Service.
0x190D	The following labware is not selected in the Labware File window: ...	Edit mode/worktable: The chosen labware is not available in the labware collection that had been selected for your lab. Possible cause for this error message: The labware has been deselected in the Labware File window.	▶ Select the respective labware in the Labware File window. You need to have the appropriate user rights. If you do not have the necessary user rights ask your administrator.
0x190E	The following tool is not selected in the Labware File Window: ...	Edit mode/procedure: The chosen tool is not available in the labware collection that had been selected for your lab. Possible cause for this error message: The labware has been deselected in the Labware File window.	▶ Select the respective labware in the Labware File window. You need to have the appropriate user rights. If you do not have the necessary user rights ask your administrator.
0x190F	The following liquid is not selected in the Labware File Window: ...	Edit mode/procedure: The chosen liquid option is not available in the labware collection that had been selected for your lab. Possible cause for this error message: The labware has been deselected in the Labware File window.	This selection could only be deactivate/activate by Eppendorf Service. ▶ Call local Eppendorf Service.

Code	Symptom/message	Cause	Remedy
0x1910	The method was written for another workstation configuration The position of the following labware is not available on this worktable	The position of required labware is not available on this device e.g. you have a 5075 LH and the application was written on a 5075 VAC.	<ul style="list-style-type: none"> <li>▶ Load the concerned application on a compatible device, or</li> <li>▶ Modify the application until it matches the available device.</li> </ul>
	The position of the following labware is not allowed anymore yyy in location: xxx	Edit mode/worktable: The chosen labware may not be placed on the selected position anymore. Possible cause for this error message: The application has been written with a former version of the software.	<ul style="list-style-type: none"> <li>▶ Place the respective labware on another position.</li> </ul>
0x1911	The following labware has been changed, so that the pattern does not fit anymore: xxx	As it is possible to change the order or contents of an “Equipped Holder” combination, it can happen that the recent pattern of a command does not fit the new positions of the tubes.	<ul style="list-style-type: none"> <li>▶ Either change the order or contents of the “Equipped Holder” combination back to the original. Or change the pattern in the command.</li> </ul>
0x1980 to 0x1983	Program error/system error	Internal program error.	<ul style="list-style-type: none"> <li>▶ Restart application run or restart system.</li> </ul> <p>If error occurs again:</p> <ul style="list-style-type: none"> <li>▶ Call local Eppendorf Service.</li> </ul>
0x1984	No parameter for tool/liquid.	Edit mode/parameter in command <i>Sample Transfer:</i> A special file for the selected combination of tool and liquid type is not available.	<ul style="list-style-type: none"> <li>▶ Select another tool or another liquid type.</li> </ul>
0x1985	Program error/system error	Internal program error.	<ul style="list-style-type: none"> <li>▶ Restart application run or restart system.</li> </ul> <p>If error occurs again:</p> <ul style="list-style-type: none"> <li>▶ Call local Eppendorf Service.</li> </ul>
0x1986	Program error/system error	Internal program error.	<ul style="list-style-type: none"> <li>▶ Restart application run or restart system.</li> </ul> <p>If error occurs again:</p> <ul style="list-style-type: none"> <li>▶ Call local Eppendorf Service.</li> </ul>
0x1A02	The name is already used for another labware	Edit mode / labware: The same name has been defined for a different rack or another labware item.	<ul style="list-style-type: none"> <li>▶ Enter a different name.</li> </ul>
0x1A03	This position is not available for the selected labware	Edit mode/worktable: Certain worktable positions are not allowed for certain labware (e.g., tips can only be placed in the rear of the worktable).	<ul style="list-style-type: none"> <li>▶ Place the selected labware in another location.</li> </ul>

Code	Symptom/message	Cause	Remedy
0x1A04	The selected labware may not be stacked on top of labware already placed	Edit mode/worktable: Building of labware stacks on the worktable is restricted to certain labware combinations (e.g., thermorack above thermorack does not make sense).	▶ See "Cause".
0x1A06	Labware stack too high in location: xxx Maximum height: xxx mm	Edit mode/worktable: Labware stacks on the worktable may not exceed a maximum height limit (e.g., plates on adapters is allowed; reservoir holder on adapters is not allowed because the stack would become too high).	▶ See "Cause".
0x1A10	8-channel tool cannot be used for this source rack	Edit mode/parameter in command <i>Sample Transfer</i> : Source rack does not fit to 8-channel-tool (e.g.: 24-well-plate or tube rack with 24 positions).	▶ Choose another rack or another tool.
0x1A11	8-channel tool cannot be used for this destination rack.	Edit mode/parameter in command <i>Sample Transfer</i> : Destination rack does not fit the 8-channel tool (e.g. 24-well plate or tube rack with 24 positions).	▶ Choose another rack or another tool.
0x1A12	No source or destination selected	Edit mode/parameter in command <i>Sample Transfer</i> : Source or destination rack has not been selected.	▶ Select source or destination, respectively.
0x1A15	Invalid entry for movement blow (0 ... 100)	Edit mode/parameter in transfer command: A value beyond the allowed range has been entered for the parameter <i>Movement Blow</i> .	▶ Enter a value between 0 and 100%.
0x1A16	Invalid entry for delay blow (0 ... 9999)	Edit mode/parameter in transfer command: A value beyond the allowed range has been entered for the parameter <i>Delay Blow</i> .	▶ Enter a value between 0 and 9999 msec.
0x1A17	Invalid entry for speed aspiration (0.2 ... 110)	Edit mode/parameter in transfer command: A value beyond the allowed range has been entered for the parameter <i>speed aspiration</i> .	▶ Enter a value between 0.2 and 110 mm/sec.
0x1A19	Invalid entry for speed blow (0.2 ... 110)	Edit mode/parameter in transfer command: A value beyond the allowed range has been entered for the parameter <i>Speed Blow</i> .	▶ Enter a value between 0.2 and 110 mm/sec.

Code	Symptom/message	Cause	Remedy
0x1A1A	Invalid entry for initial stroke (0 ... 100)	Edit mode/parameter in transfer command: a value beyond the allowed range has been entered for the parameter <i>initial stroke</i> .	▶ Enter a value between 0 and 100%.
0x1A20	8-channel tool cannot be used for this source rack	Edit mode/parameter in command <i>Reagent Transfer</i> : Source rack does not fit the 8-channel tool (e.g., 24-well plate or tube rack with 24 positions).	▶ Choose another rack or another tool.
0x1A21	8-channel tool cannot be used for this destination rack	Edit mode/parameter in command <i>Reagent Transfer</i> : Destination rack does not fit the 8-channel tool (e.g., 24-well plate or tube rack with 24 positions).	▶ Choose another rack or another tool.
0x1A22	No source or destination selected	Edit mode/parameter in command <i>Reagent Transfer</i> : Source or destination rack has not been selected.	▶ Select source or destination, respectively.
0x1A30	8-channel tool cannot be used for this source rack	Edit mode/parameter in command <i>Pool</i> : Source rack does not fit the 8-channel tool (e.g., 24-well plate or tube rack with 24 positions).	▶ Choose another rack or another tool.
0x1A31	8-channel tool cannot be used for this destination rack	Edit mode/parameter in command <i>Pool</i> : Destination rack does not fit the 8-channel tool (e.g. 24-well plate or tube rack with 24 positions).	▶ Choose another rack or another tool.
0x1A32	No source or destination selected	Edit mode/parameter in command <i>Pool</i> : Source or destination rack has not been selected.	▶ Select source or destination, respectively.
0x1A40	8-channel tool cannot be used for this source rack	Edit mode/parameter in command <i>PoolOneDest</i> : Source rack does not fit the 8-channel tool (e.g., 24-well plate or tube rack with 24 positions).	▶ Choose another rack or another tool.
0x1A41	8-channel tool cannot be used for this destination rack	Edit mode/parameter in command <i>PoolOneDest</i> : Destination rack does not fit the 8-channel tool (e.g. 24-well plate or tube rack with 24 positions).	▶ Choose another rack or another tool.
0x1A42	No source or destination selected	Edit mode/parameter in command <i>PoolOneDest</i> : Source or destination rack has not been selected.	▶ Select source or destination, respectively.

Code	Symptom/message	Cause	Remedy
0x1A50	8-channel tool cannot be used for this source rack	Edit mode/parameter in command <i>Dilute</i> : Source rack does not fit the 8-channel tool (e.g., 24-well plate or tube rack with 24 positions).	▶ Choose another rack or another tool.
0x1A51	8-channel tool cannot be used for this destination rack	Edit mode/parameter in command <i>Dilute</i> : Destination rack does not fit the 8-channel tool (e.g. 24-well plate or tube rack with 24 positions).	▶ Choose another rack or another tool.
0x1A52	No source or destination selected	Edit mode/parameter in command <i>Dilute</i> : Source or destination rack has not been selected.	▶ Select source or destination, respectively.
0x1A61	8-channel tool cannot be used for this rack	Edit mode/parameter in command <i>Mix</i> : Rack does not fit the 8-channel tool (e.g., 24-well plate or tube rack with 24 positions).	▶ Choose another rack or another tool.
0x1A62	No rack selected	Edit mode/parameter in command <i>Mix</i> : Rack has not been selected.	▶ Select rack, respectively.
0x1A65	Invalid entry for speed (0.2 ... 110)	Edit mode/parameter in command <i>Mix</i> : A value beyond the allowed range has been entered for the parameter <i>Speed</i> .	Enter a value between 0.2 and 110 mm/sec.
0x1A70	This position is already occupied	Edit mode/pattern: When editing the pattern you have tried to select a certain position that is already occupied.	▶ Follow the direction of the edited pattern and move to a different position.
0x1A73	Delete function only available for last entry	Edit mode/pattern: Deleting a pattern position you just entered is only possible as long as you did not leave the source (or the destination, respectively).	▶ If you have to delete this position which is no more available you must edit a new pattern from the beginning (softkey <i>new pattern</i> or <i>cancel</i> ).
0x1A75	A rack may only have 384 positions	Edit mode/pattern: Not enough software memory available for editing the pattern. Maximum possible positions are 384.	▶ Choose another rack, because the chosen rack has too many positions.
0x1A76	8-channel tool cannot be used for this module rack	Edit mode/pattern: Rack does not fit the 8-channel tool (e.g., <i>Tubs + Modules (equip) + Holders</i> -combination with positions all less than 8 in Modules).	▶ Choose another rack or another tool.

Code	Symptom/message	Cause	Remedy
0x1A77	No module rack or tubes found	Edit mode/pattern: Rack does not have any positions (e.g., <i>Tubs + Modules (equip) + Holders</i> -combination with positions all less than 1 in Modules).	▶ Choose another rack.
0x1A78	Number of tubes not supported	Edit mode/pattern: One or more Modules have 3, 5, 6, 7 or more than 8 positions. This is not supported.	▶ Choose another rack.
0x1A80	Invalid entry for minutes (0 ... 99)	Edit mode/parameter in command <i>Wait</i> : A value beyond the allowed range has been entered for the parameter <i>minutes</i> .	▶ Enter a value between 0 and 99 minutes.
0x1A81	Invalid entry for seconds (0 ... 59)	Edit mode/parameter in command <i>Wait</i> : A value beyond the allowed range has been entered for the parameter <i>seconds</i> .	▶ Enter a value between 0 and 59 seconds.
0x1A90	Selecting more than one rack as Source or as Destination: All source racks (or all destination racks, resp.) must have the same well pattern	Edit mode/parameter in transfer command: The selected labwares have a different amount of wells.	▶ Choose another rack.
0x1A91	Selecting more than one rack as Source or as Destination: Rack was already selected as source rack (or as destination rack, resp.)	Edit mode/parameter in transfer command: A labware may not be selected more than once.	▶ Enter a value between 0 and 110 degrees.
0x1AE0	Invalid entry for mixing speed (0 ... 2000)	Edit mode / parameter in command "Thermomixer": a value beyond the allowed range has been entered for the parameter "speed"	Enter a value between 0 and 2000 rpm
0x1AE1	Invalid entry for minutes (0 ... 120)	Edit mode / parameter in command "Thermomixer": a value beyond the allowed range has been entered for the parameter "minutes"	Enter a value between 0 and 120 minutes
0x1AE2	Invalid entry for seconds (0 ... 59)	Edit mode / parameter in command "Thermomixer": a value beyond the allowed range has been entered for the parameter "seconds"	Enter a value between 0 and 59 seconds
0x1AE3	Invalid entry for temperature (4 ... 110)	Edit mode / parameter in command "Thermomixer": a value beyond the allowed range has been entered for the parameter "temperature"	Enter a value between 4 and 110 degrees
0x1C00 to 0x1C09	File could not be read	File damaged.	▶ Call local Eppendorf Service.

Code	Symptom/message	Cause	Remedy
0x1C0B	Sample number too large	Run mode: The number of samples you entered will fill more than one rack (source or destination, respectively) based on the programmed pattern.	<ul style="list-style-type: none"> <li>▶ Start the application again and enter a lower number of samples; or:</li> <li>▶ Enter the edit mode and program a pattern that together with the number of samples you want to run will not extend beyond one rack.</li> </ul>
0x1C0C	File could not be read	File damaged.	<ul style="list-style-type: none"> <li>▶ Call local Eppendorf Service.</li> </ul>
0x1C0D	You must clear old pattern first Press "new pattern"	Edit mode/pattern: You tried to change a stored pattern before deleting the old pattern.	<ul style="list-style-type: none"> <li>▶ Delete the old pattern by pressing the button <i>new pattern</i>.</li> </ul>
0x1C0E	You must go forward	Edit mode/pattern: When entering the pattern, the order of edited locations in the source (or destination, respectively) must be from left to right or from the top of the pattern downwards (i.e., move only in columns or in rows).	<ul style="list-style-type: none"> <li>▶ See explanation in "Cause".</li> </ul>
0x1C0F	You may only move horizontally or vertically	Edit mode/pattern: When entering the pattern the order of edited locations in the source (or destination, resp.) must be from the left to right or from top of the pattern downwards (i.e., move only in columns or in rows). Note: Error message may also occur when working with an 8-channel tool and editing another position than the upper ones (see error code 0x1C1F).	<ul style="list-style-type: none"> <li>▶ See explanation in "Cause".</li> </ul>
0x1C10	Pattern for replicates of first sample too complex	Edit mode/pattern: The pattern algorithm cannot handle this pattern.	<ul style="list-style-type: none"> <li>▶ Enter a simpler pattern if possible.</li> </ul> <p>In case this is not possible:</p> <ul style="list-style-type: none"> <li>▶ Call local Eppendorf Application Support.</li> </ul>
0x1C11	Pattern too complex	Edit mode/pattern: The pattern algorithm cannot handle this pattern. Note: See note in error 0x1C0F.	<ul style="list-style-type: none"> <li>▶ Enter a simpler pattern if possible.</li> </ul> <p>In case this is not possible:</p> <ul style="list-style-type: none"> <li>▶ Call local Eppendorf Application Support.</li> </ul>
0x1C12	Program error/system error	Internal program error.	<ul style="list-style-type: none"> <li>▶ Restart application run or restart system.</li> </ul> <p>If error occurs again:</p> <ul style="list-style-type: none"> <li>▶ Call local Eppendorf Service.</li> </ul>
0x1C13	Program error/system error	Internal program error.	<ul style="list-style-type: none"> <li>▶ Restart application run or restart system.</li> </ul> <p>If error occurs again:</p> <ul style="list-style-type: none"> <li>▶ Call local Eppendorf Service.</li> </ul>

Code	Symptom/message	Cause	Remedy
0x1C14	Pattern must fit in rows or columns	Edit mode/pattern: The basic unit of the pattern you tried to enter extends beyond a row or a column. This cannot be handled by the pattern algorithm.	<ul style="list-style-type: none"> <li>▶ Enter a simpler pattern if possible.</li> </ul> In case this is not possible: <ul style="list-style-type: none"> <li>▶ Call local Eppendorf Application Support.</li> </ul>
0x1C15	Pattern too complex	Edit mode/pattern: The pattern algorithm cannot handle this pattern. Note: See note in error 0x1C0F.	<ul style="list-style-type: none"> <li>▶ Enter a simpler pattern if possible.</li> </ul> In case this is not possible: <ul style="list-style-type: none"> <li>▶ Call local Eppendorf Service.</li> </ul>
0x1C16	This position is already occupied	Edit mode/pattern: When editing the pattern you have tried to select a certain rack position that is already occupied.	<ul style="list-style-type: none"> <li>▶ Following the edited pattern move to a different rack position.</li> </ul>
0x1C17	You must start with the source	Edit mode/pattern: When editing a pattern you must start with the source.	<ul style="list-style-type: none"> <li>▶ See explanation in "Cause".</li> </ul>
0x1C18	Please enter a source now	Edit mode/pattern: In the destination rack, you tried to enter more replicates than you had sources.	<ul style="list-style-type: none"> <li>▶ Enter the same number of replicates for all sources you edit when programming a pattern.</li> </ul>
0x1C19	Please enter a destination now	Edit mode/pattern: When having selected a source in the "Sample Transfer" command you first have to enter a destination for this source before moving to the next source position	<ul style="list-style-type: none"> <li>▶ Edit the destination position(s) for the selected source position.</li> </ul>
0x1C1A	No more positions available (limited by <b>Number of Samples</b> command)	Edit mode/pattern: Editing further positions is not possible because the limit set in the <i>Number of Samples</i> command would be exceeded.	<ul style="list-style-type: none"> <li>▶ Select a pattern that fits the programmed <i>Number of Samples</i> command.</li> </ul>
0x1C1B	Program error/system error	Internal program error.	<ul style="list-style-type: none"> <li>▶ Restart application run or restart system.</li> </ul> If error occurs again: <ul style="list-style-type: none"> <li>▶ Call local Eppendorf Service.</li> </ul>
0x1C1C	Program error/system error	Internal program error.	<ul style="list-style-type: none"> <li>▶ Restart application run or restart system.</li> </ul> If error occurs again: <ul style="list-style-type: none"> <li>▶ Call local Eppendorf Service.</li> </ul>
0x1C1D	Program error/system error	Internal program error.	<ul style="list-style-type: none"> <li>▶ Restart application run or restart system.</li> </ul> If error occurs again: <ul style="list-style-type: none"> <li>▶ Call local Eppendorf Service.</li> </ul>

Code	Symptom/message	Cause	Remedy
0x1C1E	Pattern for reagent transfer: source can be chosen only once	Edit mode/pattern for command <i>Reagent Transfer</i> . After having entered the source and the destinations for the reagent transfer you cannot select an additional source.	<ul style="list-style-type: none"> <li>▶ Enter the source only once. In case this does not meet your requirements for this application consider selecting command <i>Sample Transfer</i> instead of <i>Reagent Transfer</i>; or:</li> <li>▶ Call local Eppendorf Application Support.</li> </ul>
0x1C1F	Pattern with 8-channel tool: Please edit upper position of this tool	Edit mode/pattern with 8-channel tool: Only the upper positions of the 8-channel tools can be selected.	<ul style="list-style-type: none"> <li>▶ See explanation in "Cause".</li> </ul>
0x1C20	Pattern for sample transfer: only one position per sample on source	Edit mode/pattern for command <i>Sample Transfer</i> . Before selecting a second source position, you have to edit the destination for the first source position.	<ul style="list-style-type: none"> <li>▶ Enter destination for the source you just selected; afterwards, you can edit the next source position.</li> </ul>
0x1C21	In source rack further positions cannot be edited because positions in destination rack are already occupied	Edit mode/pattern: Selecting further source positions would require a second destination rack according to the pattern you edited.	<ul style="list-style-type: none"> <li>▶ Edit a pattern that does not require more than one destination rack per command. To use more destination racks, create additional commands.</li> </ul>
0x1C22	Pattern for pool one dest: destination can be chosen only once	Edit mode/pattern for command <i>PoolOneDest</i> . After having entered the sources and the destination, you cannot select an additional destination.	<ul style="list-style-type: none"> <li>▶ Enter the destination only once. In case this does not meet your requirements for this application, consider selecting command <i>Pool</i> instead of <i>PoolOneDest</i>; or:</li> <li>▶ Call local Eppendorf Application Support.</li> </ul>
0x1C23	Pattern for dilute: only one position per sample on source	Edit mode/pattern for command <i>Dilute</i> . Before selecting a second source position, you have to edit the destination for the first source position.	<ul style="list-style-type: none"> <li>▶ Enter destination for the source you just selected; afterwards, you can edit the next source position.</li> </ul>
0x1C25	Pattern for pool: only one position per sample on destination	Edit mode/pattern for command <i>Pool</i> . Before selecting a second destination position, you have to edit the next source positions to be pooled into this destination.	<ul style="list-style-type: none"> <li>▶ Enter sources for the next destination position; afterwards, you can edit the next destination position.</li> </ul>
0x1C26	Pattern for <i>Reagent Transfer</i> : not enough source positions	Run mode: To provide enough reagent volume for the number of samples you entered, the selected reagent source positions must be higher.	<ul style="list-style-type: none"> <li>▶ Start the application again and enter a lower number of samples; or:</li> <li>▶ Enter the edit mode and program more reagent source positions in the pattern. Keep in mind that the selected reagent source positions may not extend beyond one rack.</li> </ul>
0x2025	Bottom tolerance too big	Bottom tolerance too big.	<ul style="list-style-type: none"> <li>▶ Use a smaller value.</li> </ul>

Code	Symptom/message	Cause	Remedy
0x2026	Bottom tolerance too small	Bottom tolerance too small.	▶ Use a bigger value.
0x2027	(SVC_ILLEGAL_NODE_TYPE)	Internal error.	▶ Call local Eppendorf Service.
0x2100	Program error/system error	Internal program error.	▶ Restart application run or restart system. If error occurs again: ▶ Call local Eppendorf Service.
0x2101	Tool not defined.	Parameter <i>Pipet. Tool</i> was not edited in the application.	▶ See explanation in "Cause".
0x2102	Tool not selected in the Labware File Window	The pipette tool you edited in the application is not selected in the Labware File Window and therefore is not available for programming.	This selection could only be deactivate/activated by Eppendorf Service. ▶ Call local Eppendorf Service.
0x2104	Tips not edited in worktable/ procedure	Tips were edited in the procedure of the application, but they were not edited in the worktable (e.g., filter tips <-> tips without filter).	▶ Edit the tips that you programmed in the procedure in the worktable.
0x2105	Parameter conflict: Start volume greater than filling volume of source tube or well	The <i>Volume</i> and <i>Source</i> parameters of the source vessel do not match ( <i>Volume</i> is higher than the maximum filling volume of the source vessel).	▶ Edit <i>Volume</i> and <i>Source</i> in the worktable so that <i>Volume</i> is covered by the maximum filling volume of the source vessel.
0x2106	Parameter conflict: Start volume greater than filling volume of destination tube or well	The <i>Volume</i> and <i>Destination</i> parameters of the destination vessel do not match ( <i>Volume</i> is higher than the maximum filling volume of the destination vessel).	▶ Edit <i>Volume</i> and <i>Destination</i> in the worktable so that <i>Volume</i> is covered by the maximum filling volume of the destination vessel.
0x2107	Volume not defined	Parameter <i>Volume</i> was not edited in the application.	▶ See explanation in "Cause".
0x2108	Parameter conflict: Volume too small for this tool	The <i>Volume</i> and <i>Pipet. Tool</i> parameters of the application do not match ( <i>Volume</i> is smaller than the lower limit of the tool volume range).	▶ Edit <i>Volume</i> and <i>Pipet. Tool</i> so that <i>Volume</i> is covered by the volume range of the pipette tool.
0x2109	Parameter conflict: Volume too large for this tool	The <i>Volume</i> and <i>Pipet. Tool</i> parameters of the application do not match ( <i>Volume</i> is higher than the upper limit of the tool volume range).	▶ Edit <i>Volume</i> and <i>Pipet. Tool</i> so that <i>Volume</i> is covered by the volume range of the pipette tool.
0x210A	Parameter conflict: volume greater than filling volume of source tube or well	The <i>Volume</i> and <i>Source</i> parameters of the application do not match ( <i>Volume</i> is higher than the maximum filling volume of the source vessel).	▶ Edit <i>Volume</i> and <i>Source</i> so that <i>Volume</i> is covered by the maximum filling volume of the source vessel.
0x210B	Parameter conflict: volume greater than filling volume of destination tube or well	The <i>Volume</i> and <i>Destination</i> parameters of the application do not match ( <i>Volume</i> is higher than the maximum filling volume of the destination vessel).	▶ Edit <i>Volume</i> and <i>Destination</i> so that <i>Volume</i> is covered by the maximum filling volume of the destination vessel.

Code	Symptom/message	Cause	Remedy
0x210D	Source rack not defined	Parameter <i>Source</i> was not edited in the application.	▶ See explanation in "Cause".
0x210E	Source rack not edited in worktable	The source rack you edited in the procedure of the application has been removed from the worktable.	▶ Edit the rack that you programmed in the procedure as <i>Source</i> in the worktable, or edit a different source rack in the application.
0x210F	Source rack not selected in the Labware File Window	The source rack you edited in the application is not selected or removed in the Labware File Window and therefore is not available for programming.	▶ Select the rack in the Labware File Window or edit a different rack in the application.
0x2110	Destination rack not defined	Parameter <i>Source</i> was not edited in the application.	▶ See explanation in "Cause".
0x2111	Destination rack not edited in worktable	Destination rack was edited in the procedure of the application, but it was not edited in the worktable.	▶ Edit the rack that you programmed in the procedure as <i>Destination</i> in the worktable or edit a different destination rack in the application.
0x2112	Destination rack not selected in the Labware File Window	The destination rack you edited in the application is not selected or removed in the Labware File Window and therefore is not available for programming.	▶ Select the rack in the Labware File Window or edit a different rack in the application.
0x2113	Pattern not defined	Parameter <i>Pattern</i> was not edited in the application.	▶ See explanation in "Cause".
0x2114	Loading error (invalid entry in pattern)	Normally a system error; but may also be caused by editing a pattern without destination positions; or: File damaged.	▶ Edit a pattern with source and destination positions. In other cases: ▶ Call local Eppendorf Service.
0x211B	Liquid type not defined	Parameter <i>Liquid Type</i> was not edited in the application.	▶ Choose a "Liquid Type" for the Liquid Handling Command.
0x211C	Liquid type not selected in the Labware File Window	The <i>Liquid Type</i> you choose in the application is not selected or removed in the Labware File Window and therefore is not available for programming.	This selection could only be deactivate/activated by Eppendorf Service. ▶ Call local Eppendorf Service.
0x211D	Mixing cycles in source not defined	Parameter <i>No. of Cycles</i> in a mix procedure was not edited for the source in the application (mix procedure as defined in a command <i>Mix</i> or as part of a liquid transfer command via parameter <i>Options</i> ).	▶ See explanation in "Cause".
0x211E	Invalid entry for mixing cycles in source (1 ... 99)	Entry for the <i>No. of Cycles</i> parameter in a mix procedure for source vessels was higher than the max. limit (1 up to 99 cycles) (mix procedure as defined in a command <i>Mix</i> or as part of a liquid transfer command via parameter <i>Options</i> ).	▶ Enter a number between 1 and 99 for the <i>No. of Cycles</i> parameter.

Code	Symptom/message	Cause	Remedy
0x211F	Invalid entry for mixing speed in source (1 ... 10)	Entry for the parameter <i>Speed</i> in a mix procedure for source vessels was higher than the max. limit (1 up to 10) (mix procedure as defined in a command <i>Mix</i> or as part of a liquid transfer command via parameter <i>Options</i> ).	▶ Enter a number between 1 and 10 for the <i>Speed</i> parameter.
0x2120	Mixing volume in source not defined	Parameter <i>Volume</i> in a mix procedure for source vessels was not edited in the application (mix procedure as defined in a command <i>Mix</i> or as part of a liquid transfer command via parameter <i>Options</i> ).	▶ See explanation in "Cause".
0x2121	Parameter conflict: mixing volume in source too large for this tool	The <i>Volume</i> and <i>Pipet. Tool</i> parameters of a mix procedure for source vessels are not in agreement ( <i>Volume</i> is higher than the upper limit of the tool's volume range) (mix procedure as defined in a command <i>Mix</i> or as part of a liquid transfer command via parameter <i>Options</i> ).	▶ Edit <i>Volume</i> and <i>Pipet. Tool</i> so that <i>Volume</i> is within pipette tool's volume range.
0x2122	Parameter conflict: mixing volume in source too small for this tool	The <i>Volume</i> and <i>Pipet. Tool</i> parameters of a mix procedure for source vessels do not match ( <i>Volume</i> is less than the lower limit of the tool's volume range) (mix procedure as defined in a command <i>Mix</i> or as part of a liquid transfer command via parameter <i>Options</i> ).	▶ Edit <i>Volume</i> and <i>Pipet. Tool</i> so that <i>Volume</i> is within the pipette tool's volume range.
0x2123	Parameter conflict: mixing volume in source greater than filling volume of source tube or well	The <i>Volume</i> and <i>Source</i> parameters of a mix procedure in the application do not match ( <i>Volume</i> is higher than the maximum filling volume of the source vessel) (mix procedure as defined in a command <i>Mix</i> or as part of a liquid transfer command via parameter <i>Options</i> ).	▶ Edit <i>Volume</i> and <i>Source</i> so that <i>Volume</i> is within the allowable filling volume of the source vessel.
0x2124	Mixing cycles in destination not defined	Parameter <i>No. of Cycles</i> in a mix procedure for destination vessels was not edited in the application (mix procedure as part of a liquid transfer command via parameter <i>Options</i> ).	▶ See explanation in "Cause".
0x2125	Invalid entry for mixing cycles in destination (1 ... 99)	Entry for the parameter <i>No. of Cycles</i> in a mix procedure for destination vessels was higher than the max. limit (1 up to 99 cycles) (mix procedure as part of a liquid transfer command via parameter <i>Options</i> ).	▶ Enter a number between 1 and 99 for the <i>No. of Cycles</i> parameter.

Code	Symptom/message	Cause	Remedy
0x2126	Invalid entry for mixing speed in destination (1 ... 10)	Entry for the parameter <i>Speed</i> in a mix procedure for destination vessels was higher than the max. limit (1 up to 10) (mix procedure as part of a liquid transfer command via parameter <i>Options</i> ).	▶ Enter a number between 1 and 10 for the <i>Speed</i> parameter.
0x2127	Mixing volume in destination not defined	Parameter <i>Volume</i> in a mix procedure for destination vessels was not edited in the application (mix procedure as part of a liquid transfer command via parameter <i>Options</i> ).	▶ See explanation in "Cause".
0x2128	Parameter conflict: mixing volume in destination too large for this tool	The <i>Volume</i> and <i>Pipet. Tool</i> parameters in a mix procedure for destination vessels do not match ( <i>Volume</i> is higher than the upper limit of the tool volume range) (mix procedure as part of a liquid transfer command via parameter <i>Options</i> ).	▶ Edit <i>Volume</i> and <i>Pipet. Tool</i> so that <i>Volume</i> is within the pipette tool's volume range.
0x2129	Parameter conflict: mixing volume in destination too small for this tool	The <i>Volume</i> and <i>Pipet. Tool</i> in a mix procedure for destination vessels do not match ( <i>Volume</i> is lower than the minimum allowed volume) (mix procedure as part of a liquid transfer command via parameter <i>Options</i> ).	▶ Edit <i>Volume</i> and <i>Pipet. Tool</i> so that <i>Volume</i> is within the volume range of the pipet tool.
0x212A	Parameter conflict: mixing volume in destination greater than filling volume of destination tube or well	The <i>Volume</i> and <i>Destination</i> parameters in a mix procedure for destination vessels do not match ( <i>Volume</i> is higher than the maximum filling volume of the destination vessel) (mix procedure as part of a liquid transfer command via parameter <i>Options</i> ).	▶ Edit <i>Volume</i> and <i>Destination</i> so that <i>Volume</i> is within the maximum filling volume of the destination vessel.
0x212C	Parameter conflict: mix after dispense not allowed in multidispense mode	When the <i>transfer type</i> parameter is set to <i>multidispense</i> , the <i>mix after dispense</i> parameter cannot be edited for this command.	▶ Change parameter <i>transfer type</i> to <i>pipette</i> ; or: ▶ Omit the mixing step; in this case you could also edit another mixing step as a new command ( <i>Mix</i> ), which would be performed after the previous command of the procedure has ended.
0x212D	Parameter conflict: 8-channel tool cannot be used for this source rack	Edit mode / parameter in liquid handling command: Source rack does not fit the 8-channel tool (e.g., 24-well plate or tube rack with 24 positions).	▶ Choose another rack or another tool.
0x212E	Parameter conflict: 8-channel tool cannot be used for this destination rack	Edit mode / parameter in liquid handling command: Destination rack does not fit the 8-channel tool (e.g. 24-well plate or tube rack with 24 positions).	▶ Choose another rack or another tool.

Code	Symptom/message	Cause	Remedy
0x212F	Sample number too large	The number of samples you have entered will fill more than one rack (source or destination, respectively) based on the programmed pattern.	▶ Program a pattern that together with the number of samples you want to run will not extend beyond one rack, or choose a lower number of samples in the corresponding <i>Number of Samples</i> command.
0x2130	Parameter conflict: tip cannot be used for this source rack	The <i>Source rack</i> parameter in the liquid handling command does not match the selected tool (e.g., 384-well plate and TS_1000 or TM1000_8).	▶ Choose another rack or another tool.
0x2131	Parameter conflict: tip cannot be used for this destination rack	The <i>Destination rack</i> parameter in the liquid handling command does not match the selected tool (e.g., 384-well plate and TS_1000 or TM1000_8).	▶ Choose another rack or another tool.
0x2132	Invalid number of samples (1 ... 384)	Number of samples you have entered is too high.	▶ Enter a maximum number of samples up to 384.
0x2136	Invalid entry for seconds (1 ... 59)	Edit mode/parameter in command <i>Wait</i> : A value beyond the allowed range has been entered for the <i>seconds</i> parameter.	▶ Enter a value between 0 and 59 seconds.
0x2137	Invalid entry for minutes (1 ... 99)	Edit mode/parameter in command <i>Wait</i> : A value above the allowable maximum minutes has been entered for the <i>minutes</i> parameter.	▶ Enter a value between 0 and 99 minutes.
0x2138	Method without active commands	application contains only passive commands (like wait, comment, etc.).	▶ Insert at least one active command.
0x2139	Parameter conflict: mix before aspirating not allowed in multiaspirate mode	Pool/POD: Mix before aspirating not allowed in multiaspirate mode.	▶ Do not mix.
0x213A	Labware to be exchanged are identical	Parameter in command <i>Exchange</i> : Both values point to the same labware.	▶ Enter a new labware for one of the two positions.
0x213A	Labware to be exchanged are identical	Parameter in command <i>Exchange</i> : Both values point to the same labware.	▶ Enter a new labware for one of the two positions.
0x2170	Parameter conflict: Parameter elution from filter is only possible when filter plates have been selected as source	To edit the <i>elution from filter</i> option a filter plate must have been edited as source.	▶ See explanations in "Cause".
0x2171	Parameter conflict: Multidispense mode is not allowed when selected elution from filter	See explanation in the error message.	▶ See explanation in the error message.

Code	Symptom/message	Cause	Remedy
0x2172	Parameter conflict: Transfer volume must be set to zero when Parameter elution from filter has been selected	Using the <i>elution from filter</i> option, the complete volume contained in the filter plate wells is always aspirated; therefore, editing a volume to be transferred is not possible.	▶ Set the volume to zero because the entry will not have an effect in the application run.
0x2173	Elution from filter is only possible in a sample transfer	File damaged.	▶ Call local Eppendorf Service.
0x2191	Exchange command not possible because no liquid handling station available	The chosen application may not be run on the selected device. Possible cause for this error message: The application has been written for another device.	▶ Load the concerned application on an other device, or ▶ delete Exchange commands in the application.
0x2201	Hardware error Carrier: final position in x always found	X-axis motor: Home switch always on.	▶ Call local Eppendorf Service.
0x2207	Hardware error Carrier: steps lost in x	X-axis motor: Steps lost.	▶ Call local Eppendorf Service.
0x220A	(SMOT_IOCTL_ERR)	X-axis motor: Unknown driver error code.	▶ Call local Eppendorf Service.
0x220B	(SMOT_BADPARAMS)	X-axis motor: error bad parameters.	▶ Call local Eppendorf Service.
0x220C	(SMOT_ALREADYONPOS)	X-axis motor: already in position.	▶ Call local Eppendorf Service.
0x2301	Hardware error Carrier: final position in y always found	Y-axis motor: Home switch always on.	▶ Call local Eppendorf Service.
0x2307	Hardware error Carrier: steps lost in y	Y-axis motor: Steps lost.	▶ Call local Eppendorf Service.
0x230D	Hardware error Carrier: steps lost in y	Y-axis motor: Steps lost.	▶ Call local Eppendorf Service.
0x230E	Hardware error Carrier: final position in y not found	Y-axis motor: Home not found.	▶ Call local Eppendorf Service.
0x230F	Hardware error Carrier: final position in y not found	Y-axis motor: Home not found.	▶ Call local Eppendorf Service.
0x2401	Hardware error Carrier: final position in z always found	Z-axis motor: Home switch always on.	▶ Call local Eppendorf Service.
0x2402	Hardware error Carrier: final position 2 in z not found	Z-axis motor: Home2 not found.	▶ Call local Eppendorf Service.
0x2403	Hardware error Carrier: final position 2 in z always found	Z-axis motor: Home2 switch always on.	▶ Call local Eppendorf Service.

Code	Symptom/message	Cause	Remedy
0x2404	Hardware error Carrier: final position in z wrong	Z-axis motor: Wrong home switch.	▶ Call local Eppendorf Service.
0x2407	Hardware error Carrier: steps lost in z	Z-axis motor: Steps lost.	▶ Call local Eppendorf Service.
0x240D	Hardware error Carrier: steps lost in z	Z-axis motor: Steps lost.	▶ Call local Eppendorf Service.
0x240E	Hardware error Carrier: final position in z not found	Z-axis motor: Home not found.	▶ Call local Eppendorf Service.
0x240F	Hardware error Carrier: final position in z not found	Z-axis motor: Home not found.	▶ Call local Eppendorf Service.
0x2F00	Communication error during transmission to Trinamic module	Hardware error The communication with the Trinamic module is failing.	Shut down and switch off the instrument; if error re-occurs after switching on: Call Eppendorf Service
0x2F01	Communication error during reception from Trinamic module	Hardware error The communication with the Trinamic module is failing.	Shut down and switch off the instrument; if error re-occurs after switching on: Call Eppendorf Service
0x2F02	Checksum error during reception from Trinamic module	Hardware error The checksum from the Trinamic module is failing.	Shut down and switch off the instrument; if error re-occurs after switching on: Call Eppendorf Service
0x2F03	Communication error during reception from Trinamic module	Hardware error The communication with the Trinamic module is failing.	Shut down and switch off the instrument; if error re-occurs after switching on: Call Eppendorf Service
0x2F06	Mixer motor cannot find its home position	Hardware error Mixer motor cannot find its home position	Shut down and switch off the instrument; if error re-occurs after switching on: Call Eppendorf Service
0x2F08	Clamping device cannot write to spi bus	Hardware error Communication with clamping device is failing.	Shut down and switch off the instrument; if error re-occurs after switching on: Call Eppendorf Service
0x2F0A	Clamping device did not reach operating current	Hardware error The gear belt of the clamping device may be failing.	Shut down and switch off the instrument; if error re-occurs after switching on: Call Eppendorf Service
0x2F0C	Clamping device limit switch has wrong position	Hardware error	Shut down and switch off the instrument; if error re-occurs after switching on: Call Eppendorf Service
0x3000	Temperature unit 1 in location C1 reports an invalid temperature	The temperature unit "TEMP1" in position C1 is damaged and showed an invalid temperature.	Shut down and switch off the instrument; if error re-occurs after switching on: Call Eppendorf Service
0x3001	Temperature unit 2 in location C2 reports an invalid temperature	The temperature unit "TEMP2" in position C2 is damaged and showed an invalid temperature.	Shut down and switch off the instrument; if error re-occurs after switching on: Call Eppendorf Service
0x3002	Temperature unit 3 in location C3 reports an invalid temperature	The temperature unit "TEMP3" in position C3 is damaged and showed an invalid temperature.	Shut down and switch off the instrument; if error re-occurs after switching on: Call Eppendorf Service

Code	Symptom/message	Cause	Remedy
0x3003	The thermomixer reports an invalid temperature	The temperature unit of the thermomixer is damaged and showed an invalid temperature.	Shut down and switch off the instrument; if error re-occurs after switching on: Call Eppendorf Service
0x3004	Temperature unit 1 in location C1 cannot heat	The temperature unit "TEMP1" in position C1 is damaged and do not heat.	Shut down and switch off the instrument; if error re-occurs after switching on: Call Eppendorf Service
0x3005	Temperature unit 2 in location C2 cannot heat	The temperature unit "TEMP2" in position C2 is damaged and do not heat.	Shut down and switch off the instrument; if error re-occurs after switching on: Call Eppendorf Service
0x3006	Temperature unit 3 in location C3 cannot heat	The temperature unit "TEMP3" in position C3 is damaged and do not heat.	Shut down and switch off the instrument; if error re-occurs after switching on: Call Eppendorf Service
0x3007	The thermomixer cannot heat	The temperature unit of the thermomixer is damaged and do not heat.	Shut down and switch off the instrument; if error re-occurs after switching on: Call Eppendorf Service
0x3008	Temperature unit 1 in location C1 cannot cool	The temperature unit "TEMP1" in position C1 is damaged and does not cool.	Shut down and switch off the instrument; if error re-occurs after switching on: Call Eppendorf Service
0x3009	Temperature unit 2 in location C2 cannot cool	The temperature unit "TEMP2" in position C2 is damaged and does not cool.	Shut down and switch off the instrument; if error re-occurs after switching on: Call Eppendorf Service
0x300A	Temperature unit 3 in location C3 cannot cool	The temperature unit "TEMP3" in position C3 is damaged and does not cool.	Shut down and switch off the instrument; if error re-occurs after switching on: Call Eppendorf Service
0x300B	The thermomixer cannot cool	The temperature unit of the thermomixer is damaged and does not cool.	Shut down and switch off the instrument; if error re-occurs after switching on: Call Eppendorf Service

## 7 Maintenance

### 7.1 Service

#### 7.1.1 Replacing the sealing rings of the eight-channel dispensing tool

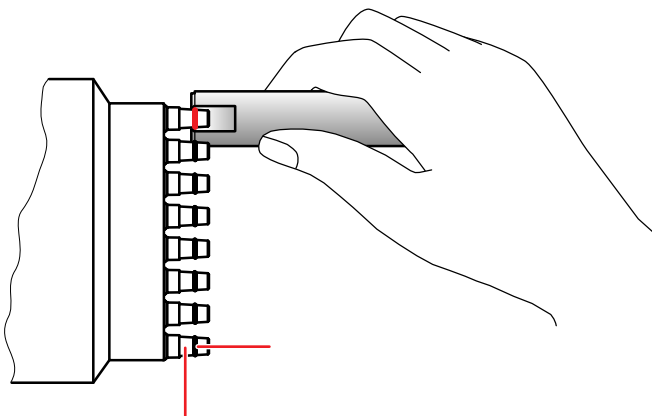

1 Sealing ring

2 Tip cone



NOTICE!

#### Damage to the gold contacts from handling.

The connection to the PCB of the dispensing tool is interfered with or interrupted if the gold contacts on the dispensing tool are damaged or dirtied.

- ▶ Do not touch the gold contacts.



Replace the sealing rings annually or as required.

Use the auxiliary tool and the mounting aid included with the delivery of the dispensing tool.

Carry out the following steps to replace the sealing rings:

1. Attach the edge of the auxiliary tool at the level of the sealing ring.
2. Cut the sealing ring at the dispensing tool with the help of the auxiliary tool.
3. Remove the sealing ring by hand.
4. Clean the tip cones with a lightly moist and lint-free cloth.
5. Repeat the process for all other sealing rings and tip cones.
6. Attach the new sealing rings with the help of the mounting tool (shortened pipette tip) and position the sealing rings in the recessed grooves of the tip cones.

#### 7.1.2 Maintaining the dispensing tools



NOTICE!

#### A lack of servicing will impair reliable dispensing.

Servicing of the dispensing tools is essential after 200,000 full strokes. This is the only way to ensure reliable dispensing.

- ▶ Note the warning in the software reporting that 200,000 full strokes have been reached and have the dispensing tools serviced.
- ▶ Send the dispensing tool for maintenance to your service partner of Eppendorf AG.

## 7.2 Cleaning

### 7.2.1 Cleaning the worktable



#### Damage from UV radiation.

UV radiation can cause color changes to the surface or, in the course of time, cause damage to the moving parts and electronics of the epMotion.

- ▶ Avoid UV radiation.



If the worktable becomes contaminated during operation, remove such contamination as quickly as possible.

1. Clean the worktable with a 70% ethanol solution or with hypochlorite-containing agents (3%) and a lint-free cloth.
2. Clean the worktable in the area of the spring plate using a cotton bud if necessary.

### 7.2.2 Cleaning the work surface adapter

1. Clean the work surface adapter with alcohol-containing disinfectants and a lint-free cloth. Do not use any cleaning agents which contain sodium hypochlorite.
2. Wipe off the disinfectants after they have had time to take effect.

### 7.2.3 Cleaning the dispensing tools

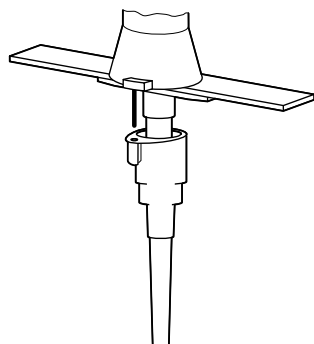

1. Remove the ejector of the single-channel tools.
2. Clean the tip cones and surfaces with water or a 70% ethanol solution or with hypochlorite-containing (3%) agents and a lint-free cloth.
3. Wipe off the disinfectants after they have had time to take effect.

### 7.2.4 Cleaning the barcode reader



#### Damage to device from ingress of liquid or abrasive materials and wipes.

- ▶ Do not immerse the barcode reader in water.
  - ▶ Do not wipe the window with abrasive materials and wipes.
  - ▶ Never use solvents (for example acetone, benzene, ether, or phenol-based agents).
- ▶ If contaminated, clean the barcode reader with a moist cloth and mild cleaning agents (e.g., washing-up liquid) or plastic cleaner fluid.

### 7.2.5 Cleaning the thermoadapter, thermoblock and thermorack

1. Wipe down thermoadapter, thermoblock and thermorack with alcohol-containing disinfectant or with Na hypochlorite (3 to 4%) and a lint-free cloth.
2. Wipe off the disinfectants after they have had time to take effect.

### 7.2.6 Autoclaving Labware

- ▶ Autoclave the thermoadapter, thermoblock and thermorack for 20 minutes at 121 °C and 1 bar pressure.

### 7.3 Decontamination before shipment

If you want to send the dispensing tool to be checked, repaired or calibrated by Eppendorf AG or one of its service partners, please observe the following:

Hazardous substances are:

- solutions presenting a hazard to health
  - potentially infectious agents
  - organic solvents and reagents
  - radioactive substances
  - proteins presenting a hazard to health
  - DNA
- ▶ Follow the instructions in the decontamination certificate. These can be found as a PDF file on our homepage [www.eppendorf.de](http://www.eppendorf.de).
  - ▶ Decontaminate all the parts you want to dispatch.
  - ▶ Include the completed and signed decontamination certificate for returned goods with your shipment (incl. the serial number of the dispensing tool).

## 8 Technical data



The following technical data apply exclusively to the automatic pipetting system epMotion. For technical data on the PC and the keyboard please refer to the appropriate operating instructions.

### 8.1 Power supply

Voltage	100 to 240 V ±10%
Fuses	Type T 2.5 AH / 250 V
Current consumption	< 1.5 A
Frequency	50 Hz to 60 Hz ±5%
Power consumption	max. 80 W
Overvoltage category	II (IEC 610 10-1)
Degree of contamination:	2
Protection class	1

### 8.2 Ambient conditions

General operation	+15°C to +35°C 55% to 75% rel. humidity up to 2000 m NN
Storage conditions	-20°C to +70°C 10% to 80% rel. humidity

### 8.3 Weight/dimensions

Device	
Width	65 cm
Depth	48 cm
Height	63 cm

Automatic pipetting system epMotion 5070	45 kg
--	-------

### 8.4 Interfaces

Interface	Specification
USB	USB 2.0
Ethernet	Ethernet 100 MBit/s

## 8.5 Dispensing Tools

Data for free-jet pipetting using double-distilled water. Data analysis in accordance with ISO 8655.

Temperature approx. 20 °C, standard air pressure.

Dispensing tool	Volume range	Volume	Error			
			systematic (falsity)		Random (imprecision)	
			%	µL	%	µL
TS 50	1.0 µL to 50 µL	1 µL	±15	±0.2	±5.0	±0.05
		5 µL	±5.0	±0.25	±3.0	±0.15
		25 µL	±1.5	±0.375	±0.6	±0.15
		50 µL	±1.2	±0.6	±0.4	±0.2
TS 300	20 µL to 300 µL	20 µL	±4.0	±0.8	±2.5	±0.5
		30 µL	±3.0	±0.9	±1.5	±0.45
		150 µL	±1.0	±1.5	±0.4	±0.6
		300 µL	±0.6	±1.8	±0.3	±0.9
TS 1000	40 µL to 1.000 µL	40 µL	±5.0	±2.0	±1.5	±0.6
		100 µL	±2.0	±2.0	±1.0	±1.0
		500 µL	±1.0	±5.0	±0.2	±1.0
		1,000 µL	±0.7	±7.0	±0.15	±1.5
TM 50-8	1.0 µL to 50 µL	1 µL	±25	±0.25	±10	±0.1
		5 µL	±5.0	±0.25	±5.0	±0.25
		25 µL	±2.0	±0.5	±1.5	±0.375
		50 µL	±1.2	±0.6	±0.7	±0.35
TM 300-8	20 µL to 300 µL	20 µL	±10	±2.0	± 4.0	±0.8
		30 µL	±10	±3.0	±3.5	±1.05
		150 µL	±2.5	±3.75	±0.8	±1.2
		300 µL	±1.5	±4.5	±0.45	±1.35
TM 1000-8	40 µL to 1.000 µL	40 µL	±6.0	±2.4	±2.5	±1.0
		100 µL	±3.0	±3.0	±1.5	±1.5
		500 µL	±1.5	±7.5	±0.3	±1.5
		1,000 µL	±0.8	±8.0	±0.2	±1.5



When dispensing the defined errors for pipetting are exceeded.

## 8.6 Additional specifications

### 8.6.1 Barcode reader

Type	Manual barcode reader
Connection	USB
Weight	185 g
Barcodes supported	linear: Codabar, Code 39, Interleaved 2 of 5, Code 93, Code 128, UPC/EAN, EAN addendum 2D: Data Matrix

### 8.6.2 Noise level

Noise level	typically 53 dB (A)
-------------	---------------------

### 8.6.3 Optical sensor

Optical confocal infrared sensor	Contact-free recognition of liquid levels, inserted tools, labware surfaces, and type and quantity of pipette tips
Detection conditions	The liquid surface must be at $90 \pm 3^\circ$ in relation to the optical beam axis. The liquid height must be at least 3 mm

### 8.6.4 Carrier

<b>Working space</b>	
Width X	37 cm
Depth Y	20 cm
Height Z	20 cm
<b>X-Y-Z axis positioning</b>	
Systematic deviation	$\pm 0.3$ mm
Random deviation	$\pm 0.1$ mm

## 9 Ordering information

### 9.1 Accessories



Use only original Eppendorf accessories or accessories (labware) approved by Eppendorf AG on the epMotion.

#### 9.1.1 Automated pipetting system epMotion 5070

Order no. (international)	Order No. (North America)	Description
5070 000.140	960000100	<b>Automated pipetting system epMotion 5070 with integrated PC</b> as 5070 700.000 plus integrated industrial PC, keyboard and mouse

#### 9.1.2 Dispensing tools

Order no. (international)	Order No. (North America)	Description
5280 000.010	960001010	<b>Single-channel dispensing tool TS 50</b> Volume range 1 µL - 50 µl
5280 000.037	960001028	<b>Single-channel dispensing tool TS 300</b> Volume range 20 µ - 300 µl
5280 000.053	960001036	<b>Single-channel dispensing tool TS 1000</b> Volume range 40 µL - 1000 µl
5280 000.215	960001044	<b>Eight-channel-dispensing tool TM 50</b> Volume range 1 µL - 50 µl
5280 000.231	960001052	<b>Eight-channel-dispensing tool TM 300</b> Volume range 20 µ - 300 µl
5280 000.258	960001061	<b>Eight-channel-dispensing tool TM 1000</b> Volume range 40 µL - 1000 µl
5075 774.003	960001109	<b>Holder for 6 dispensing tools</b>

#### 9.1.3 epT.I.P.S. Motion pipette tips.

Order no. (international)	Order No. (North America)	Description
0030 014.405 0030 015.207	0030014405 0030015207	<b>epT.I.P.S. Motion 50 µL</b> 10 racks with 96 tips each Eppendorf Quality Sterile
0030 014.448 0030 015.223	0030014448 0030015223	<b>epT.I.P.S. Motion 300 µL</b> 10 racks with 96 tips each Eppendorf Quality Sterile
0030 014.480 0030 015.240	0030014480 0030015240	<b>epT.I.P.S. Motion 1 000 µL</b> 10 racks with 96 tips each Eppendorf Quality Sterile
0030 014.413 0030 015.215	0030014413 0030015215	<b>epT.I.P.S. Motion Filter 50 µL</b> 10 racks with 96 tips each PCR clean PCR clean and Sterile

Order no. (international)	Order No. (North America)	Description
0030 014.456 0030 015.231	0030014456 0030015231	<b>epT.I.P.S. Motion Filter 300 µL</b> 10 racks with 96 tips each PCR clean PCR clean and Sterile
0030 014.499 0030 015.258	0030014499 0030015258	<b>epT.I.P.S. Motion Filter 1 000 µL</b> 10 racks with 96 tips each PCR clean PCR clean and Sterile
0030 014.421	0030014421	<b>epT.I.P.S. Motion Reloads 50 µL</b> 12 × 2 trays with 96 tips each Eppendorf Quality
0030 014.464	0030014464	<b>epT.I.P.S. Motion Reloads 300 µL</b> 12 × 2 trays with 96 tips each Eppendorf Quality
0030 014.502	0030014502	<b>epT.I.P.S. Motion Reloads 1 000 µL</b> 12 × 2 trays with 96 tips each Eppendorf Quality
0030 014.430	0030014430	<b>epT.I.P.S. Motion Filter Reloads 50 µL</b> 12 × 2 trays with 96 tips each PCR clean
0030 014.472	0030014472	<b>epT.I.P.S. Motion Filter Reloads 300 µL</b> 12 × 2 trays with 96 tips each PCR clean
0030 014.510	0030014510	<b>epT.I.P.S. Motion Filter Reloads 1 000 µL</b> 12 × 2 trays with 96 tips each PCR clean
5075 751.399		<b>TipHolder</b> for epT.I.P.S. Motion Reloads

#### 9.1.4 Reservoirs

Order no. (international)	Order No. (North America)	Description
5075 754.002	960002148	<b>ReservoirRack</b> for 30 mL and 100 mL reservoirs and ReservoirRack Module TC
0030 126.505 0030 126.513	960051009 960051017	<b>epMotion Reservoir</b> PCR clean, 10 × 5 pieces in bags 30 mL 100 mL
5075 751.364	5075751364	<b>Reservoir 400 mL</b> 10 pieces

### 9.1.5 Racks for individual tubes

Order no. (international)	Order No. (North America)	Description
5075 761.009 5075 775.000 5075 760.002 5075 776.006 5075 792.028 5075 792.044 5075 792.001 5075 792.060 5075 762.005 5075 792.087 5075 763.001 5075 792.109	960002024 960002156 960002032 960002164 960002377 960002326 960002369 960002334 960002041 960002342 960002059 960002351	<b>Racks for individual tubes</b> for use with Eppendorf vessels and glass or plastic test tubes, cannot be tempered Ø 17 mm × 100 mm max. length Ø 17 mm × 60 mm max. length Ø 16 mm × 100 mm max. length Ø 16 mm × 60 mm max. length Ø 15 mm × 100 mm max. length Ø 15 mm × 60 mm max. length Ø 14 mm × 100 mm max. length Ø 14 mm × 60 mm max. length Ø 13 mm × 100 mm max. length Ø 13 mm × 60 mm max. length Ø 12 mm × 100 mm max. length Ø 12 mm × 60 mm max. length
5075 792.125	960002380	<b>Rack</b> for 24 HPLC vessels Ø 12 mm × 40 mm max. length
5075 791.005	960002318	<b>Rack</b> for 96 × 1.5/2.0 mL conical tubes
5075 751.160 5075 751.186	960002070 960002080	<b>Thermorack TMX</b> for 24 Safe-Lock tubes 0.5 mL 1,5/2,0 mL
5075 751.453 5075 751.275		<b>Rack</b> for 24 Safe-Lock tubes 0,5/1,5/2,0 mL, cannot be tempered, with adapter sleeves für 0,5 mL 1,5/2,0 mL, cannot be tempered

### 9.1.6 ReservoirRack modules

Order no. (international)	Order No. (North America)	Description
5075 799.049 5075 799.065 5075 799.081 5075 799.103 5075 799.120 5075 799.162 5075 799.189 5075 799.146 5075 799.260	960002601 960002611 960002620 960002630 960002640 960002650 960002660 960002670 960002680	<b>ReservoirRack Module TC</b> PCR 0.2 mL PCR 0.5 mL Safe-Lock Ø 12 mm Ø 16 mm Ø 17 mm Ø 29 mm Reservoir 30 mL Reservoir 100 mL

### 9.1.7 Height adapter

Order no. (international)	Order No. (North America)	Description
5075 751.003 5075 752.000 5075 755.009	960002105 960002113 960002121	<b>Height adapter</b> 85 mm 55 mm 40 mm

### 9.1.8 Additional Accessories

Order no. (international)	Order No. (North America)	Description
5075 001.250	960021044	<b>Monitor</b> 19" TFT monitor to be used with epMotion versions with integrated PC
5075 016.001	960000309	<b>epBlue-epMotion PC Software</b> Software for epMotion Version with integrated PC, preinstalled
5075 002.000	5075002000	<b>epBlue ID upgrade kit for epMotion with integrated PC</b> With epBlue ID installation CD-ROM, recovery DVD, barcode reader, USB hardware Key (eLicenser) and hardware key code card for upgrading an epBlue or epBlue GxP system
5075 753.006	960002016	<b>Waste box</b>
5070 752.001	5070752001	<b>Work surface adapter</b> to raise the epMotion worktable 4 feet
5075 751.054	960002391	<b>Thermoadapter</b> for Deep Well Plates, 96 wells
5075 769.000 5075 771.004	960002067 960002075	<b>Thermorack</b> For 24 Safe-Lock tubes 0.5 mL 1.5/2.0 mL
5075 772.000	960002172	<b>Adapter sleeves</b> for thermorack 1.5/2.0 mL for 0.5 mL Safe-Lock tubes

### 9.1.9 Accessories for real-time PCR

Order no. (international)	Order No. (North America)	Description
5075 790.009	960002520	<b>Rack Smart</b>
5075 795.000	960002511	<b>Rack LC</b> 20 µL/100 µL
5075 751.305	5075751305	<b>Thermoadapter LC Sample</b> for MagNA Pure LC sample cartridge
5075 767.031	960002500	<b>Thermorack CB</b> 100 µL
5075 787.008 5075 788.004	960002199 960002202	<b>Thermoadapter</b> for PCR plates, 96 wells, skirted for PCR 384 wells, skirted
5075 789.000	960002300	<b>Thermoadapter Frosty</b>
5075 766.000	960002083	<b>Thermoblock</b> PCR 96 for use with vessels 0.2 mL or 77 PCR tubes 0.5 mL
5075 767.007	960002091	<b>Thermoblock</b> PCR 384
0030 128.648 0030 128.656 0030 128.664 0030 128.672 0030 128.680	951020401 951020427 951020443 951020460 951020486	<b>twin.tec PCR Plate 96, skirted</b> Wells colorless, 25 pieces low profile, border clear border yellow border green border blue border red

Order no. (international)	Order No. (North America)	Description
0030 128.800	951020508	<b>twin.tec PCR Plate 96, skirted</b> Wells black, 25 pieces border yellow
0030 128.508 0030 128.516 0030 128.524 0030 128.532 0030 128.540	951020702 951020711 951020729 951020737 951020745	<b>twin.tec PCR Plate 384</b> Wells colorless, 25 pieces border clear border yellow border green border blue border red
3881 000.015 3881 000.023 3881 000.031	022510509 022510541 022510525	<b>PCR-Cooler</b> Starter Set (1 x pink, 1 x blue) pink blue



All twin.tec plates can be obtained with bar coding on request.

10 Transport, storage and disposal

10.1 Shut down



If you decommission the epMotion for a prolonged period of time, observe the storage conditions (see *Ambient conditions on p. 158*).

Carry out the following tasks before decommissioning the epMotion:

1. Clean the epMotion and decontaminate the components (see *Cleaning on p. 156*).
2. Only have the transport of the epMotion carried out by the service department of Eppendorf AG or authorized service personnel.

10.2 Installation after transport

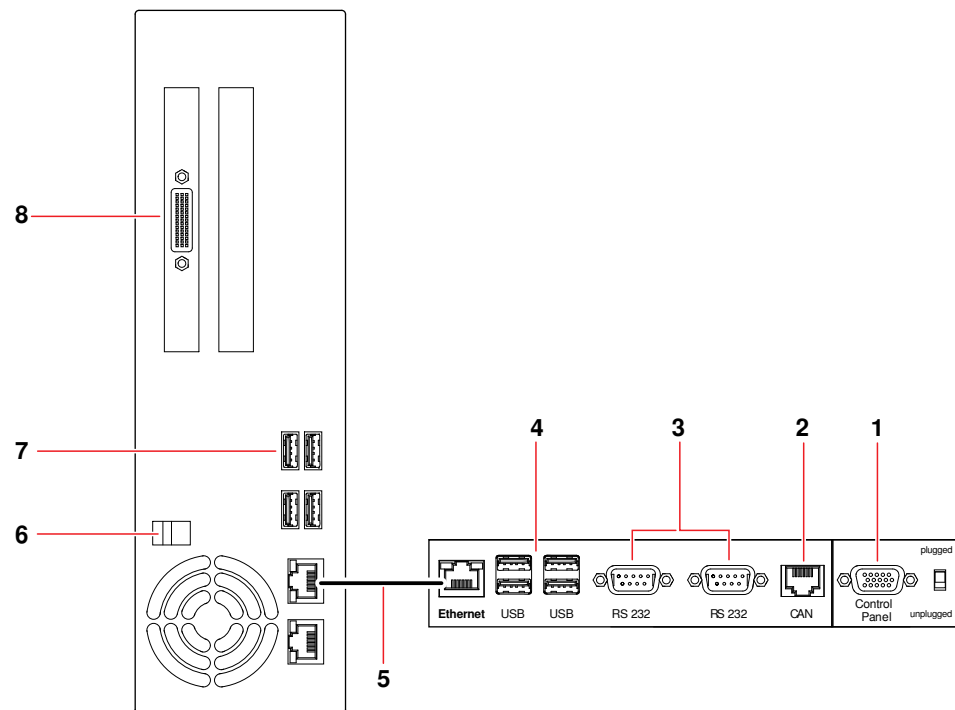

Fig. 8: System connections between epMotion PC and epMotion

1 <b>Control panel</b>	2 <b>CAN</b> For additional epMotion systems
3 <b>RS 232</b>	4 <b>USB</b>
5 <b>Ethernet</b> Connection between epMotion PC and epMotion	6 <b>PC power switch</b>
7 <b>USB</b> Connection for mouse and keyboard	8 <b>DVI monitor connection</b> DVI connection for PC display

### 10.3 Disposal

In case the product is to be disposed of, the relevant legal regulations are to be observed.

**Information on the disposal of electrical and electronic devices in the European Community:**

Within the European Community, the disposal of electrical devices is regulated by national regulations based on EU Directive 2002/96/EC pertaining to waste electrical and electronic equipment (WEEE).

According to these regulations, any devices supplied after August 13, 2005, in the business-to-business sphere, to which this product is assigned, may no longer be disposed of in municipal or domestic waste. To document this, they have been marked with the following identification:



Because disposal regulations may differ from one country to another within the EU, please contact your supplier if necessary.

In Germany, this is mandatory from March 23, 2006. From this date, the manufacturer has to offer a suitable method of return for all devices supplied after August 13, 2005. For all devices supplied before August 13, 2005, the last user is responsible for the correct disposal.

## 11 Appendix A: Hardware

### 11.1 Labware

#### 11.1.1 Introduction

Among other features, the software contains a large number of predefined consumables (tubes, pipette tips, plates etc.), racks, holders and tools etc. You will find all labware names arranged in specific subdirectories by labware type. These are explained in the following sections.

This is not a comprehensive description, as the range of labware is constantly being expanded. More information on available labware components can be found in the product description of this operating manual as well in the Internet at [www.epMotion.com](http://www.epMotion.com). **All information subject to change.**

Information about the bottom tolerance and the remaining volume can be displayed via *Open labware* (Home - create/edit labware tab) in the *Labware Properties* section.

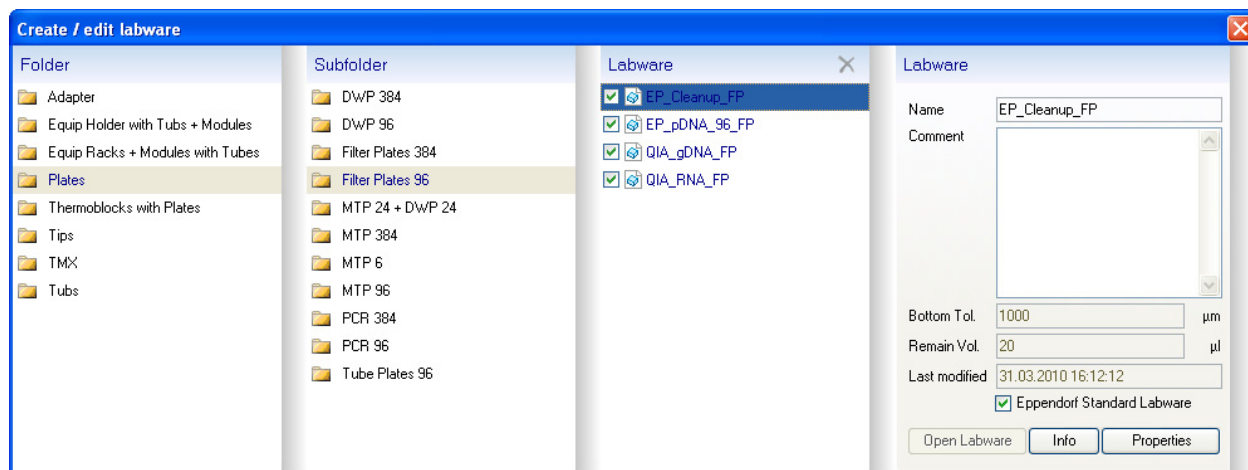

Fig. 9: Product properties in "Open labware"

You can display additional product information for selected labware, such as the article name, information about volumes, and order numbers, etc. To do so, click on *Info* in the file window or mark the desired labware in Worktable mode.



Fig. 10: Product properties in the file window (after you click on Info)

The same information is displayed in the *Labware* list of the *Work* tab (e.g., after opening an application) if a labware has been selected.

Labware-Type	Sub-Type	Labware	Information
Tips	DWP 384	96 EP_Cleanup_FP Eppendorf 96 Well Filter Plates	<b>plates/filter96/EP_Cleanup_FP</b> *Vendor-Info: Eppendorf 96 Well Filter Plates Description: Filter plate für PCR cleanup Order No.(Kit, int): 0032.007.600 Order No.(Kit, BI): 955156005 Maximal filling volume: 450 µl Working volume:300 µl Detection limit optical sensor: 66 µl Version: 1.0
Plates	DWP 96	96 EP_pDNA_96_FP Eppendorf 96 Well Filter Plate	
Equipped Racks and Modules	Filter Plates 384	96 QIA_gDNA_FP Qiagen	
Equipped Holders	Filter Plates 96	96 QIA_RNA_FP Qiagen	
Adapter	MTP 24 + DWP 24		
Lids	MTP 384		
Vacuum Frames	MTP 6		
Thermoblocks with Plates	MTP 96		
Tubs	PCR 384		
	PCR 96		
	Tube Plates 96		

Fig. 11: Product information in Worktable mode

### 11.1.2 Overview of labware

#### epT.I.P.S. Motion



Fig. 12: 1000 µL



Fig. 13: 300 µL



Fig. 14: 50 µL

epT.I.P.S. Motion are single-use tips and are intended exclusively for dispensing tools belonging to the epMotion family of devices. The pipette tips are available in three volume sizes to suit the volume of the dispensing tools (50 µL, 300 µL and 1000 µL), in each case with or without filter.

The *Tips* labware folder contains the selection of epT.I.P.S pipette tips. Motion pipette tips.

Name in labware folder	Product name
tips1000	epT.I.P.S. Motion 1000 µL
tips1000f	epT.I.P.S. Motion 1000 µL, filter
tip300	epT.I.P.S. Motion 300 µL
tip300f	epT.I.P.S. Motion 300 µL, filter
tip50	epT.I.P.S. Motion 50 µL
tip50f	epT.I.P.S. Motion 50 µL, filter

Pipette tips and racks are made of polypropylene (PP).The filter of the pipette tips is made of polyethylene (PE).



#### Positioning fault as a result of incorrect tip handling.

- ▶ Use tips only once.
- ▶ Do not autoclave tips. If purity conditions demand it, use filter tips of the PCR clean specification.
- ▶ Do not stack tip racks.

The coding on the tray informs the optical sensor about the volume of the tips and about whether or not these are tips with filters. As the coding is only on one side of the tray, the correct positioning of the rack on the worktable is important. Position the racks on the worktable so that the labeling of the rack or tip holder and the recess on the tray are facing toward you.

The optical sensor detects any supply of tips still available within a rack, i.e. tips in racks which have been started can continue to be used for subsequent methods. A prerequisite for this is that the tips in the rack are in contiguous positions.



**NOTICE!**

**Faults as a result of tips missing from the rack.**

The optical sensor detects only the initial and final position of tips in a rack. Missing tips removed from the center of a column by hand are not detected and will lead to faults in executing the method.

- ▶ Do not remove by hand any tips within an enclosed area on the rack.

A column in a tip rack which has been started and which has been created by use of a single-channel dispensing tool is detected by the software if you switch to a multi-channel dispensing tool and is not used. Tips from this started column will not be picked up until a single-channel dispensing tool is being used again later.

If you use an eight-channel dispensing tool, it will accordingly not use columns which have been started. In the case of multi-channel mode, 8 tips are always picked up simultaneously.

If the optical sensor is switched off, the tips must be placed in the rack starting with coordinate A1. Columns must be complete.

**Racks, thermoracks, thermoblock and thermoadapter**

Racks are tube holders which can hold up to 24 tubes of a type. They are supplied primarily for tubes larger than 2 mL.

Tubes with a capacity of 2 mL and below are positioned in thermoracks.

A special type is the "two-location rack". This rack can hold 96 tubes of approx. 2 mL.

**Restrictions**

<b>Rack</b>	The combination of a rack with a tube type occurs in the labware file window in the <i>Equip Racks + Modules with Tubes</i> directory.
<b>Thermorack</b>	The combination of a rack with a tube type occurs in the <i>Equip Racks + Modules with Tubes</i> directory.
<b>Thermoblock</b>	The combination of a thermoblocks with a skirted, semi-skirted or unskirted PCR plate is specified in the software. No configuration or change possible.
<b>Thermoadapter</b>	Thermo adapters are available for 96-well and 384-well PCR plates as well as for the Deepwell plates 96. When equipping the worktable, you can place a plate on the thermoadapter in a similar way to putting labware on a height adapter. In contrast to the thermoblock, the thermoadapter and plate do not form a fixed combination. The thermoadapter and the thermoblock differ in visual terms by their different web lengths. The thermoblock also has cutouts with which the gripper of the epMotion 5075 can engage.  Racks and thermoracks can be combined with tubes by users with level 2 rights or administrator rights.

**Racks for reagent tubes**

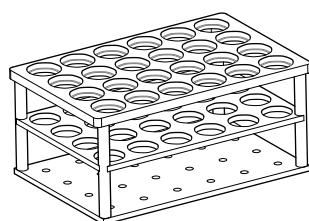

Fig. 15: Rack for 24 reagent tubes

The appropriate racks are available as tube holders for reagent tubes with diameters of 12 to 17 mm. The basic area of the racks corresponds to that of a microplate, i.e. they can be placed at any location on the worktable. The locations on a rack are numbered from 1 to 24. The rack is available in two different heights.

The optical sensor can use the coding of the racks to check that they are correctly aligned. The software issues an error message if the rack is inserted the wrong way round.

Tubes and racks may not exceed a total height of approx. 123 mm. The maximum immersion depth of the 300 µL and 500 µL tips is correspondingly less than that of the longer 1000 µL tips.

The administrator determines which tube can be used with which rack and is consequently available as a combination in the software.

### Rack LC for LightCycler capillaries

The Rack LC is a tube holder for automatically filling LightCycler capillaries. It can hold 96 capillaries with a capacity of 20 µL or 96 capillaries with a capacity of 100 µL. The bores for both sizes of capillary are arranged in an alternating pattern.

In the software you will find the Rack LC under *Plates\Tube Plates*.

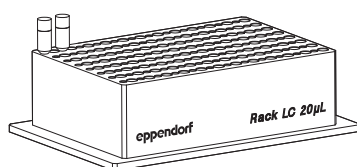

Fig. 16: Rack LC 20 µL

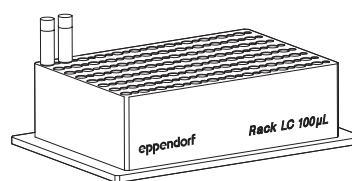

Fig. 17: Rack LC 100 µL

### Using the Rack LC

1. Position the Rack LC on the worktable with its label on the front.
2. Select the labware for filling the capillaries from the *Labware Tube Plates* list.
3. Supply the Rack LC with only one capillary size per run.

### Rack 96 (Two Location Rack)

The rack is for the absorption of cryo tubes without lid (diameter similar to Safe-Lock tubes 1.5 or 2 mL). To be able to take 96 tubes, this special rack occupies 2 locations.

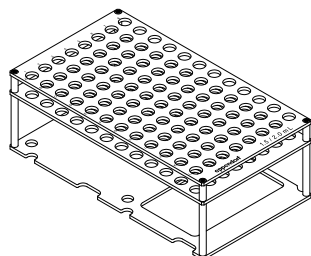

Fig. 18: Rack 96 (Two Location Rack)

### CAUTION!

#### Risk of crashing if only one location occupied by Rack 96!

- ▶ When editing the worktable for the rack 96 always occupy **two Locations** a rear and a front location (e.g., A2 and B2).
- ▶ Define the same detection variant of the optical sensor for both locations.
- ▶ After the start of a method, also always make identical changes and entries for both locations of Rack 96 in the start worktable.



Do not use any tubes with lid.

### Using Rack 96

1. Select Rack 96 in the labware folder *Equip Racks + Modules with Tubes* under the name *Rack96\_1\_5 – 2\_0*.
2. Proceed as for equipping the 96-well thermorack when equipping this rack with tubes with an attached lid (Safe-Lock type tube). The position numbering of Rack 96 is rotated by 90° compared to a 96-well plate.
3. When equipping the worktable, place Rack 96 on the pins of the two locations. In the process, the opening in the bottom tray of Rack 96 must point towards the front.

### Thermoracks and thermoracks TMX

For smaller tubes (e.g., Eppendorf Safe-Lock tube for 1.5 mL or 2 mL) a Thermorack/Thermorack TMX which can be temperature-controlled with lid holder and 24 positions is available. The tube lids are held vertically in the holder to the right of the tube bore.

With the aid of 24 adapter sleeves you can also insert into the Thermorack/Thermorack TMX Safe-Lock tubes with a volume of 0.5 mL. The Thermorack/Thermorack TMX for the use with 0.5 mL tubes is also available with inserted adapter sleeves.



### Damage to the device from placing the thermorack on the thermomixer!

The thermorack is not suitable for application in the thermomixer. Using it in the thermomixer may result in damage to the device and dispensing errors.

- ▶ Do not place the thermorack onto the thermomixer!
- ▶ Only use the thermorack TMX on the thermomixer.

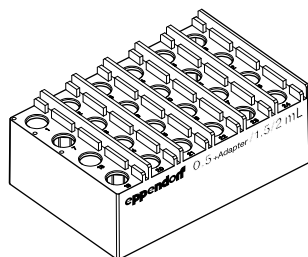

Fig. 19: Thermorack

The thermorack has a high heat capacity and retains the temperature away from the temperature-control over a longer time period. It has a slower heat transfer as the Thermorack TMX, i.e. it takes a bit longer to reach the desired temperature. Therefore the thermorack can also be applied for temperature-control on the epMotion without active temperature-control.

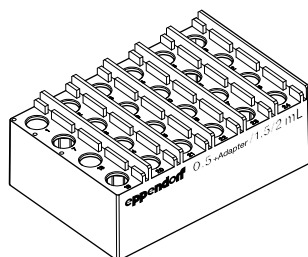

Fig. 20: Thermorack TMX

The Thermorack TMX is optimized for the application in the thermomixer as it is easier than the normal thermoracks and therefore permits higher rotational speed during mixing. It has a quick heat transfer and thus reaches the desired temperature quickly. The Thermorack TMX has a lower heat capacity as opposed to the normal thermorack and does not retain the temperature constant for a long time outside an active temperature-control. Therefore the Thermorack TMX is above all suitable for the application on a epMotion with thermo unit and/or thermomixer.

### Thermoblocks and Thermoracks (96 Wells)

The thermoblock shown is available for 96-well PCR plates (e.g., Eppendorf twin.tec semi-skirted or skirted).

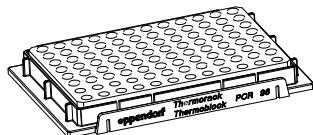

Fig. 21: Thermoblock/Thermorack

Skirted 96-well PCR plates can optionally be positioned in a location on the worktable with a 96-well thermoblock, a 96-well thermoadapter or solo if the administrator has defined them as a labware combination in the software.

Unskirted or semi-skirted 96-well PCR plates can only be positioned in a location on the worktable in conjunction with the 96-well thermoblock or 96-well thermoadapter.

The combination of Thermoblock and other PCR plates cannot be performed by the administrator, only by Eppendorf. Fixed combinations are predefined in the software for a variety of plates, e.g., for twin.tec plates.

### Special case Thermorack and 0.2 mL tubes

If the thermoblock is to be equipped with 0.2 mL PCR tubes then the thermoblock turns into a thermorack in the software. The combination of a 0.2 mL tube with the thermorack does not have to be predefined in the Labware directory at the factory, it can be effected by the administrator in the *Equip Racks + Modules with Tubes* labware folder.



### Risk of collision as a result of projecting tube lids!

Carrier travel is optimized in the z direction. As a result, the tube lids may not point upwards. They could otherwise be contacted by the tips which could lose liquid in the process.

- ▶ Position 0.2 mL individual tubes and 8-tube strips so that their tube lids do not obstruct the path of travel or dispensing steps of the dispensing tool.

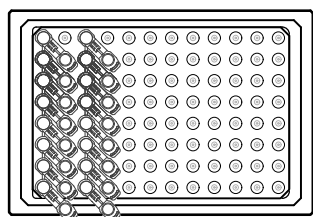

Fig. 22: Tube lid rotated by 45° in relation to the surface of the thermoblock

### Use of the thermorack with 0.2 mL tubes

1. The best arrangement for the tubes is in columns, leaving every other column free for the tube lids. Therefore you can position maximum 48 tubes in the thermoblock (see image).
2. Specify the assignment in the transport pattern when programming the method. Supply at the start must correspond to the pattern.

### Thermoblock (384 wells)

A special 384-well thermoblock is available for PCR plates with 384 wells.

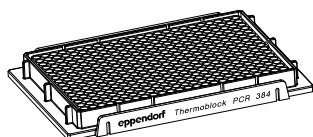

Fig. 23: Thermoblock (384 wells)

Regarding the use of the 384 PCR plates with thermoblock a fixed combination is available in the software just as with the 96-well PCR plates with thermoblock.

### Thermoadapter

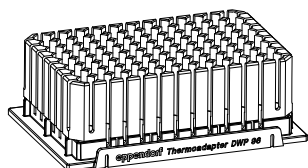

Fig. 24: Thermoadapter DWP 96

Thermo adapters can be positioned in a location with or without a plate at the start of the method. The thermoadapter forms a temporary combination with a plate. The combination is formed when the worktable is edited. In terms of their combination options, thermo adapters are similar to height adapters. A semi-skirted or unskirted PCR plate can only be used on the epMotion in combination with a thermo adapter or thermoblock.

When viewed from above, PCR thermo adapters look very similar to thermoblocks. However, they can be distinguished from one another from the side by the differing lengths of their webs.



Fig. 25: Thermoblocks and thermo adapters

### Thermoadapter LC Sample

The Thermoadapter LC Sample is a tube holder for the automated filling of MagNa Pure LC Sample Cartridges. The adapter and the cartridge form a fixed combination and cannot be transported with the gripper. The adapter can be temperature controlled up to 70°C. In the software you can find the Thermoadapter LC Sample+Cartridge under *Thermoblocks with plates*.

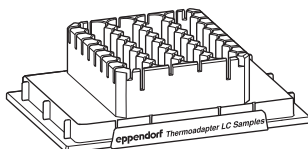

Fig. 26: Thermoadapter LC Sample

### Cooling effect of thermoracks and thermoblocks

The PCR racks are cooled by being stored in the refrigerator (passive cooling). For the continued temperature curve, the following values apply as a guide.

Thermorack or Thermoblock	Plate or Tubes Used	Filling Volume per Well or Tube	Time taken to heat from 0°C to 10°C
R 1.5 / 2 mL	1.5 mL Safe-Lock tube	1000 µL	~ 30 min.
PCR 96	96-well twin.tec PCR plate	150 µL	~ 14 min.
PCR 384	twin.tec 384-well PCR plate	25 µL	~ 10 min.

## Reservoirs and ReservoirRack

To supply liquids, reservoirs in sizes 30 mL and 100 mL are available. Up to seven reservoirs are placed in a ReservoirRack to position them on the worktable.

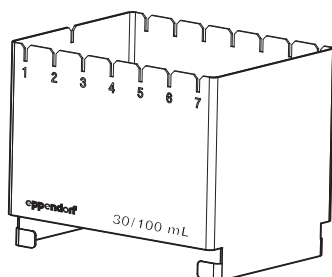

Fig. 27: ReservoirRack

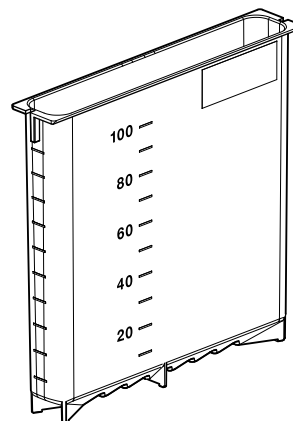

Fig. 28: 100 mL reservoir

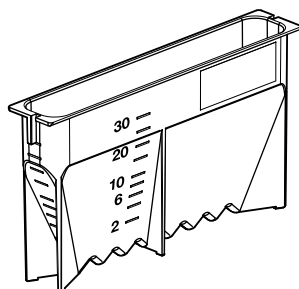

Fig. 29: 30 mL reservoir

The reservoirs are optimized for eight-channel mode:

- The 100 mL reservoir is recommended for 1000  $\mu$ L tips.
- The 30 mL reservoir is suitable for all pipette tip sizes.
- In conjunction with the eight-channel dispensing tool, 50  $\mu$ L and 300  $\mu$ L tips cannot reach the bottom of a 100 mL reservoir.

Some combinations of reservoirs in the ReservoirRack are already predefined in the software. As administrator, you can furthermore define new combinations of reservoirs and ReservoirRacks.

For larger volumes, an autoclavable reservoir with a capacity of 400 mL is available. The remaining volume with these reservoirs is approx. 10 mL. The reservoir is made of polypropylene (PP).

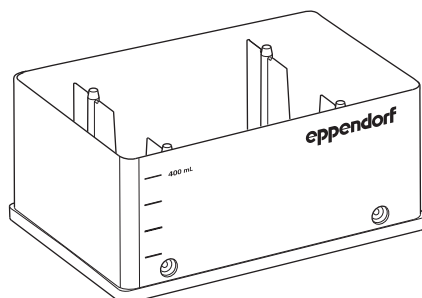

Fig. 30: 400 mL reservoir (Eppendorf)

### ReservoirRack with ReservoirRack module

Up to 7 different ReservoirRack modules can be equipped with vessels in the ReservoirRack. Tubes can be placed in the ReservoirRack when they are in ReservoirRack modules and reservoirs with holders which can be temperature-controlled. The same tubes must be used within a ReservoirRack module. The ReservoirRack can be equipped in any sequence.

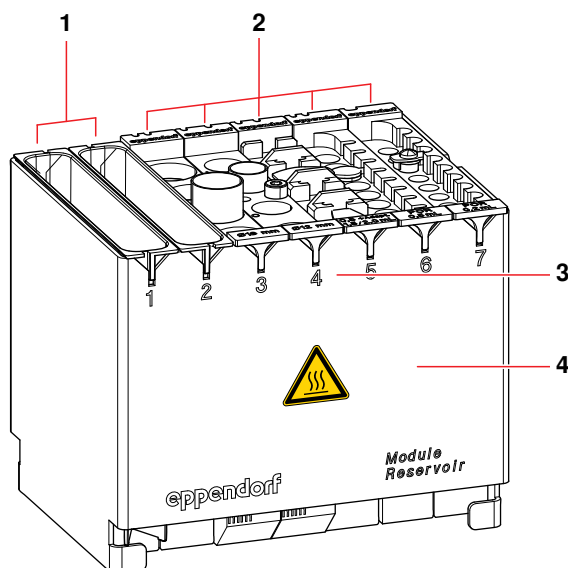
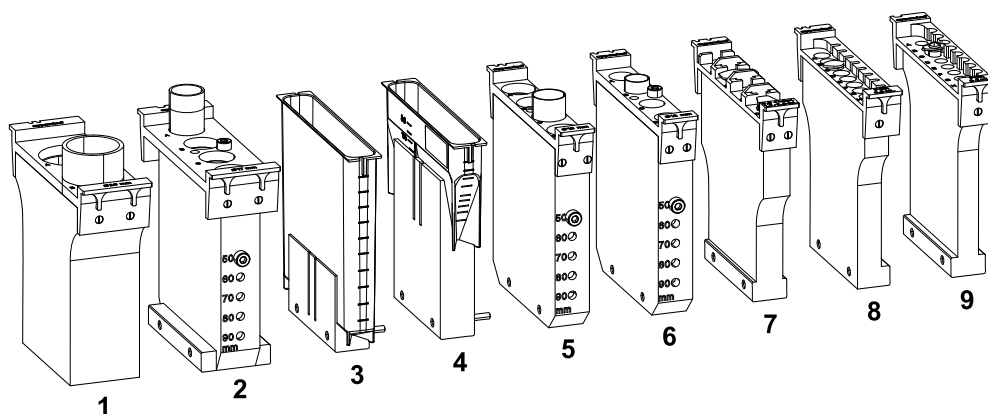

Fig. 31: Equipped ReservoirRack

<b>1 Reservoirs</b>	<b>2 ReservoirRack modules</b>
<b>3 Locations in the ReservoirRack</b>	<b>4 ReservoirRack</b>

The following ReservoirRack Modules TC (temperature-controlled) can be used:



Item No.	Description	Labware name for software
1	RR Module TC Ø 29 mm	Module TC 29 mm
2	RR Module TC Ø 17 mm	Module TC 17 mm
3	RR Module TC Ø 100 mL	Module TC Reserv100ml
4	RR Module TC Reservoir 30 mL	Module TC Reserv30ml
5	RR Module TC Ø 16 mm	Module TC 16mm
6	RR Module TC Ø 12 mm	Module TC 12mm

Item No.	Description	Labware name for software
7	RR Module TC Safe Lock	Module TC Safe Lock (for 2 mL and 1.5 mL Safe-Lock tubes) and Module TC Safe Lock 0.5ml (for 0.5 mL Safe-Lock tubes) (use with adapter)
8	RR Module TC PCR 0.5 mL	Module TC PCR0_5ml
9	RR Module TC PCR 0.2 mL	Module TC PCR0_2ml

Insert the ReservoirRack modules square in the rack with the coding facing backwards.



**Material damage as a result of incorrect positioning of module racks.**

If the module racks have been put in the reservoir rack with the code facing forwards, there is a risk of collision and faulty dispensing.

- ▶ Ensure that all module racks are inserted correctly.

If you use the 30 mL and 100 mL reservoirs with holders which can be temperature-controlled, they must be fastened via two connecting webs on each ReservoirRack module.

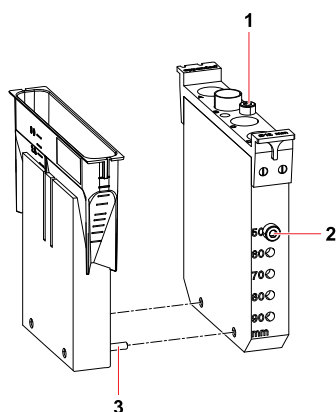

<b>1 Adjusting pin in the depositing position</b>	<b>2 Adjusting pin (here height adjustment 50 mm)</b>
<b>3 Connecting bar</b>	

Bores in the ReservoirRack module with diameters 12, 16 and 17 mm and two pins enable tubes of five different heights (5 50, 60, 70, 80, 90 mm) to be positioned. Both pins must be inserted on both sides at the desired height, even if not all the positions are occupied by tubes. The ReservoirRack modules with the diameters 17 and 29 mm occupy two positions in the ReservoirRack.

The equipped ReservoirRacks can be positioned in any location with the exception of the A locations.

If you are using the ReservoirRack with ReservoirRack modules and reservoirs in your method, you can only use irregular patterns. Exception: the ReservoirRack is occupied throughout with identically equipped ReservoirRack modules or reservoirs. In this case, the pattern with automatic pattern detection and the standard pattern (in the case of sample transfer) can also be used.

The level detection and *ID Label* option (only epBlue ID) can be separately adjusted for each ReservoirRack module.



**NOTICE!**

**Material damage as a result of the gripper colliding with the module rack.**

- ▶ Ensure that module rack and tubes do not exceed a height of 123 mm.

**Equipping ReservoirRack modules**

The following list contains possible arrangements of ReservoirRack modules with defined tubes:

<b>Rack</b>	<b>Tube (labware name)</b>	<b>Manufacturer</b>
RR Module TC Ø 12 mm	BD_Tube_5ml_1	BD Biosciences
	CHA_Tube_6_2ml	Chase
	GR_Tube_5ml	Greiner
	SAR_Tube_4_5ml	Sarstedt
	SAR_Tube_5000	Sarstedt
RR Module TC Ø 16 mm	BD_Tube_11ml	BD Biosciences
	BD_Tube_12ml	BD Biosciences
	BS_Tube_13ml	Bibby Sterilin
	Gr_Tube_11ml	Greiner
	SAR_Tube_10ml	Sarstedt
	SAR_Tube_11ml	Sarstedt
	QSP_Tube_11_5ml	QSP
	USP_Tube_10ml	USA Scientific plastic
RR Module TC Ø 17 mm	BD_Tube_14ml	BD Biosciences
	GR_Tube_14ml	Greiner
	GR_Tube_15ml	Greiner
	SAR_Tube_11ml_1	Sarstedt
	SAR_Tube_14ml_3	Sarstedt
	SAR_Tube_14ml_2	Sarstedt
	SAR_Tube_14_5ml	Sarstedt
RR Module TC Ø 29 mm	Roth_Tube_54ml	Roth

### Temperature control of ReservoirRack modules

The following values are intended as guide values for temperature-controlling ReservoirRack modules.

ReservoirRack modules	Vessel	Temperature change from 23 °C to 4 °C		Temperature change from 23 °C to 37 °C	
		Set temperature	Temperature control duration	Set temperature	Temperature control duration
3 x RR Module TC PCR 0.2 mL or RR Module TC PCR 0.5 mL	PCR reaction vessel 0.2 mL PCR reaction vessel 0.5 mL	3 °C	approx. 15 min.	38 °C	approx. 8 min.
3 x RR Module TC Safe Lock	Safe Lock 0.5 mL Safe Lock 1.5 mL Safe Lock 2.0 mL	3 °C 2 °C 3 °C	approx. 20 min.	38 °C	approx. 12 min.
3 x RR Module TC Ø 12 mm or RR Module TC Ø 16 mm or 2 x RR Module TC Ø 17 mm	Reaction vessel Ø 12 mm Reaction vessel Ø 16 mm Conical tube 15 mL	3 °C 3 °C 2 °C	approx. 30 min.	38 °C	approx. 17 min.
2 x RR Module TC Ø 29 mm	Conical tube 50 mL	3 °C	approx. 39 min.	39 °C	approx. 23 min.
1 x RR Module TC Reservoir 30 mL	Reservoir 30 mL	1 °C	approx. 21 min.	39 °C	approx. 15 min.
1 x RR Module TC Ø 100 mL	Reservoir 100 mL	1 °C	approx. 46 min.	40 °C	approx. 28 min.

### Height adapter

In order to keep transfer times and distances as short as possible for the carrier, there are various height adapters which can be used to compensate for plates of differing heights.

Height Adapter and plate may not exceed a total height of 123 mm. Combinations taller than 123 mm are rejected with an error message during configuration of the worktable.

For this reason, racks and reservoir holders may not be placed on height adapters.

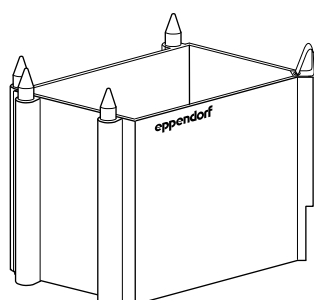

Fig. 32: Height adapter

The adapters are marked with the height in question. The following heights are available.

**40 mm:** This adapter is suitable for use with 50 µL and 300 µL tips, for example. Labware which fits on taller height adapters can likewise be positioned here.

**55 mm:** This adapter is suitable for deepwell plates, 300 mL reservoirs, semi-skirted or unskirted PCR plates in a thermoblock and for some skirted PCR plates in a thermoblock, for example.

**85 mm:** This adapter is suitable for almost all microplates from 6 to 384 wells as well as almost all PCR plates with 96 or 384 wells. The Eppendorf PCR plate twin.tec (skirted, 96 or 384 wells) can be inserted with a thermoblock at this height.

### Thermoadapter Frosty

The Frosty thermoadapter is a special type. It is particularly suitable for users who have used the Eppendorf PCR Cooler during manual PCR setup and who wish to continue using this form of cooling. To do so, the cooling unit of the PCR Cooler is placed in a modified height adapter and a skirted PCR plate (e.g., a 96-well twin.tec PCR plate) positioned on that. Other PCR plates cannot be used. The cooling unit cannot be equipped with 0.2 mL PCR tubes when it is used in the epMotion.

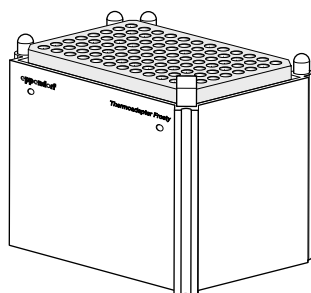

Fig. 33: Modified height adapter and cooling unit or "Frosty Thermoadapter"

The cooling unit does not affect the overall height of height adapter and skirted PCR plate.

Note on editing the method: when editing the worktable for the Frosty Thermoadapter (*Adap\_frosty*), only select a skirted PCR plate for the location. The cooling unit to be used is not named in the software.

Notes on the cooling unit.

- The unit should be deep-frozen with the underside of the unit facing upwards.
- The cooling unit then displays the overshooting of a temperature of 7°C by changing color from purple to pink or from dark blue to light blue. A key factor in cooling samples is the color value in the depressions in the cooling unit.
- The cooling action of the cooling unit is comparable to manual use of the PCR Cooler.

## Plates

Files are available for the following labware:

- Microplates (MTP) with different numbers of wells
- Deepwell plate (DWP) with different numbers of wells
- Skirted PCR plates with different numbers of wells
- Filter plates
- Tube plates with 96 individual tubes
- Rack for microtubes in a 96-well grid

The plates described here can be positioned straight onto the surface of the worktable at a location. The prerequisite for this is that the plates in question have been activated in the software (see *Activate or deactivate labware on p. 93*).

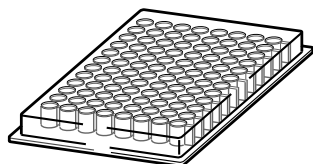

Fig. 34: Microplate (MTP) with 96 wells

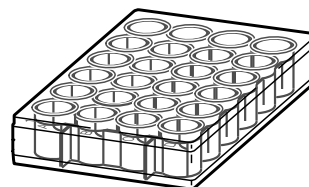

Fig. 35: Microplate (MTP) with 24 wells

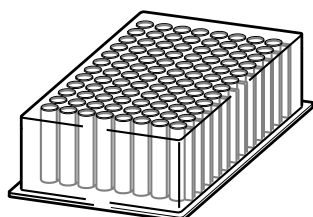

Fig. 36: Deepwell plate (DWP) with 96 wells



Plates and racks must be inserted at right-angles to the base.

In the *Plates* labware folder you will find a large selection of various plates. These are arranged in specific subfolders by plate type:

Tab. 2: Plates labware folder

MTP 96	Microplates, 96 wells
MTP 384	Microplates, 384 wells
MTP 24 + DWP 24	Microplates and deepwell plate, 24 wells
MTP 6	Microplate, 6 wells
PCR 96	PCR plates, 96 wells
PCR 384	PCR plates, 384 wells
DWP 96	Deepwell plate, 96 wells
DWP 384	Deepwell plate, 384 wells
Filter Plates 96	Filter plates, 96 wells
Filter Plates 384	Filter plates, 384 wells
Tube Plates 96	Plates with up to 96 individually removable tubes

### 11.1.3 Abbreviations used

Each labware Name includes information about the manufacturer and labware type, e.g., **EP\_pDNA\_384\_MTP\_1** (EP = Eppendorf, pDNA\_384 = Collection Plate for PerfectPrep Plasmid 384 Kit, MTP = micro test plate). If a manufacturer abbreviation is not used, it is an Eppendorf item. The following sections contain explanations of the abbreviations used.

**Manufacturer**

<b>Abbreviation</b>	<b>Manufacturer</b>
AB	Abgene
AXYG	Axygen Scientific
ABI	Applied Biosystems
BD	BD Biosciences
BRAN	BRAND
BS	Barloworld Scientific
CO	Corning/Costar
ELK	Elkay
EP	Eppendorf AG
FALC	Falcon
GENE	Genetix
GR	Greiner
IWA	Iwaki
LAMB	One Lambda
MAT	Matrix
MI	Millipore
MJ	MJ Research
MN	Macherey+Nagel
NUNC	Nunc/Nalgene
PACK	Packard
PALL	Pall
POR	Porex
PR	Promega
ROB	Robbins
QIA	Qiagen
SAR	Sarstedt
SCI	Scientific
TPP	TPP
USP	USA Scientific
WHAT	Whatman

#### Other abbreviations in labware names

Abbreviation	Description
DWP	Deepwell plate (DWP) with 24, 96 or 384 wells
FP	Filter plate
MTP	Micro test plate with 6, 24 ... 96, 384 wells
PCR	Plate for PCR (Polymerase Chain Reaction)
TP	Tube plate (plate with individually removable tubes)
Cleanup	Plate is included in the PCR Cleanup Kit
DNA/RNA	Plate is included in the kit for purification/isolation
TT	Eppendorf twin.tec
PCR Plate Thermo	Fixed combination of thermoblock and PCR plate
Numbers	For example, <i>_5ml_</i> or <i>_200_</i> = maximum filling volume (each tube or well) in mL or µL

#### 11.1.4 Labware definitions

The following folders are present for labware and labware combinations:

Labware folder/	Content	Description
<i>Tips</i>	pipette tips	(see p. 169)
<i>Plates</i>	Various subfolders for plates (e.g., MTP 96, Tube Plates)	(see p. 180)
<i>Equip Racks + Modules with Tubes</i>	Combinations of racks, thermoracks and tubes and Safe-Lock tubes and for equipping ReservoirRack modules	(Fig. 16 on p. 171) and (see p. 176)
<i>Equip Holder with Tubs + Modules</i>	For reservoirs, equipped ReservoirRack modules and the ReservoirRack	(see p. 176) and (see p. 178)
<i>Adapters</i>	Height adapters and thermoadapters	(see p. 179) and (see p. 174)
<i>Thermoblocks with plates</i>	Fixed combinations of skirted PCR plates (in which passive temperature-control of the thermoblock is to be used) and semi-skirted or unskirted PCR plates (which cannot be placed in a location without an adapter). In these cases, the thermoblock functions as an adapter and if required, for temperature-control.	(see p. 173)
<i>Tubs</i>	Reservoirs with a capacity of 400 mL or 300 mL which can be positioned in a location without an additional holder	(see p. 175)

#### 11.1.5 Compile your own labware combinations

The labware combinations are summarized in the labware file window in folders. You can activate or deactivate labware in the folders.

You can also create your own labware combinations from the components that are available (e.g., rack-tube combinations), or delete them using the icon or the Delete pop-up menu.

When editing a method, activated labware combinations as well as activated labware are displayed in a list.

Folder for labware and labware combinations and liquids



Beyond the preconfigured standard labware available ex works, it is also possible to dimension individual or external labware for use with the epMotion 5070 and to incorporate it in the labware directories of the software. For more information on this, contact Eppendorf Service.

Requesting labware definitions



You can find more than 350 labware files for downloading at [www.epMotion.com](http://www.epMotion.com).

If tubes or plates you require are not yet defined in the software, send the appropriate request to the following address:

Eppendorf AG  
 Application Support:  
 Phone: +49 180 366 67 89  
 E-mail: [support@eppendorf.com](mailto:support@eppendorf.com)  
 Fax +49 538 01 556 or +49 539 901 25

11.2 Tools (dispensing tools)

Dispensing tools are piston-stroke pipettes working on the air-cushion principle. If the piston in the dispensing tool moves up, liquid can be aspirated into the tip. Piston movements in a downward direction dispense the liquid. The piston movement is effected by a stepper motor in the carrier, in all 8 channels simultaneously in multi-channel tools.

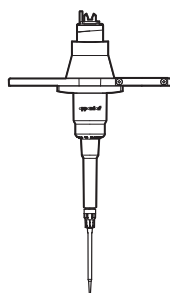

Fig. 37: Single channel dispensing tool TS 50, volume range 1-50 µL

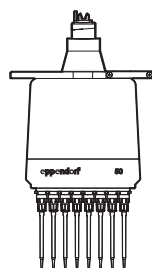

Fig. 38: Eight channel dispensing tool TM 50-8, volume range 1-50 µL

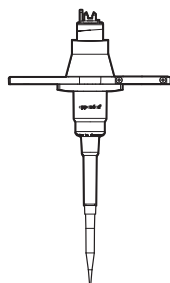

Fig. 39: Single channel dispensing tool TS 300, volume range 20-300 µL

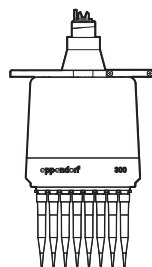

Fig. 40: Eight channel dispensing tool TM 300-8, volume range 20-300 µL

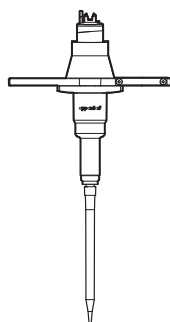

Fig. 41: Single channel dispensing tool  
TS 1000, volume range 40-1000  $\mu\text{L}$

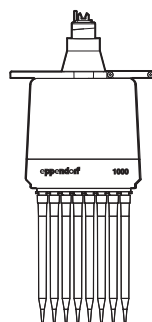

Fig. 42: Eight channel dispensing tool  
TM 1000-8, volume range 40-1000  $\mu\text{L}$

More information about tools can be found in the product description of this operating manual (see *Dispensing tools (tools) on p. 14*).

Following the start of a method, all the subsequent steps run fully automatically.

- If required, the Optical Sensor checks the correct selection, positioning and filling level of tubes and the supply of tips in Tip Racks.
- The correct dispensing tool is detected by the code in the tool.
- Depending on the dispensing tool, one or eight pipette tips are picked up.
- If the further procedure has been defined in the method by supply of the worktable and in the procedure by commands, the carrier moves the dispensing tool to the source location. The required liquid is aspirated. The carrier then moves the dispensing tool to the first destination location.

Furthermore

- Water can be pipetted from 1  $\mu\text{L}$  and multidispensed from 3  $\mu\text{L}$ .



An undershooting of the recommended dispensing volumes is possible but it is your own responsibility. Ensure that in this case the dispensing for your application is sufficient.

- 
- Depending on the method, other destination positions are possible. The dispensing or transport pattern is likewise specified within the command.
  - The number of samples can be entered at the start or specified with priority in the method.
  - The time of the pipette tip change can likewise be programmed.
  - Liquid can likewise be mixed in the pipette tip before aspiration and after dispensing.
  - Optimum dispensing parameters are achieved by selecting a liquid type in the commands.
  - If other commands in a method require different dispensing tools, the change in dispensing tool which will have to be performed by the user is shown in the display in the started method.

## 11.3 Optical sensor

### 11.3.1 Function

The optical sensor (U.S. Pat. No. 6,819,437) is used, among other things, for detecting the filling level of tubes. If you are working in a method with defined and constant volumes and you specify these when editing the method, filling level detection can be dispensed with. On MTPs with 384 wells and 0.2 and 0.5 mL tubes, it is not possible to measure liquid. Liquid measurement is not recommended for MTPs with 96 wells.

#### Principle

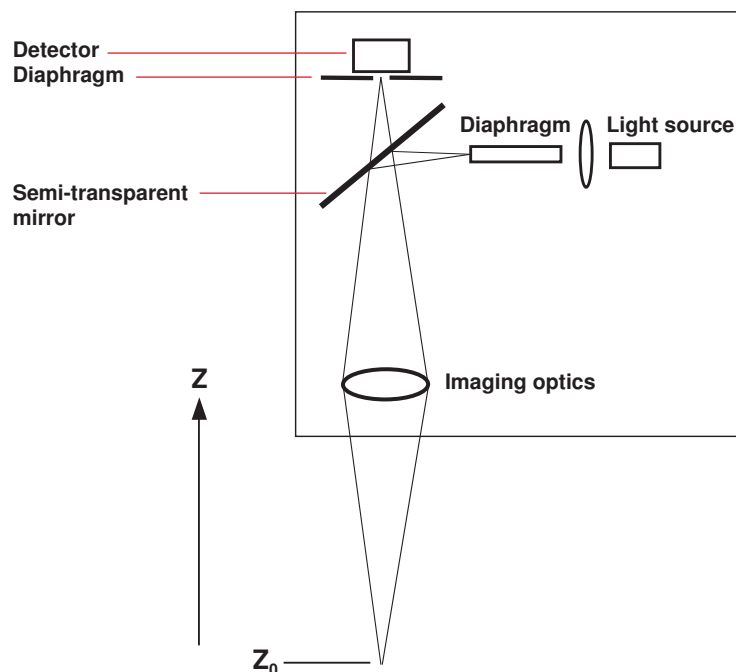

The reflection of light is detected by a receiver with the aid of a lateral light source, a semi-transparent mirror, a lens and motion in the z direction in the desired position; the software then evaluates the maximum. The reflections of light provide information about surfaces and liquid level. Detection operations can be performed using the reflections of light.

Use the *Functions* tab to define a default setting for the optical sensor:

- Liquid detection (detection of liquid surfaces) (see p. 188)
- Tips (tip detection) (see p. 189)
- Locations (detection of location occupation) (see p. 191)

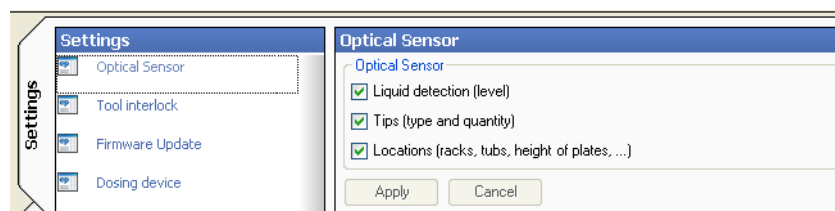
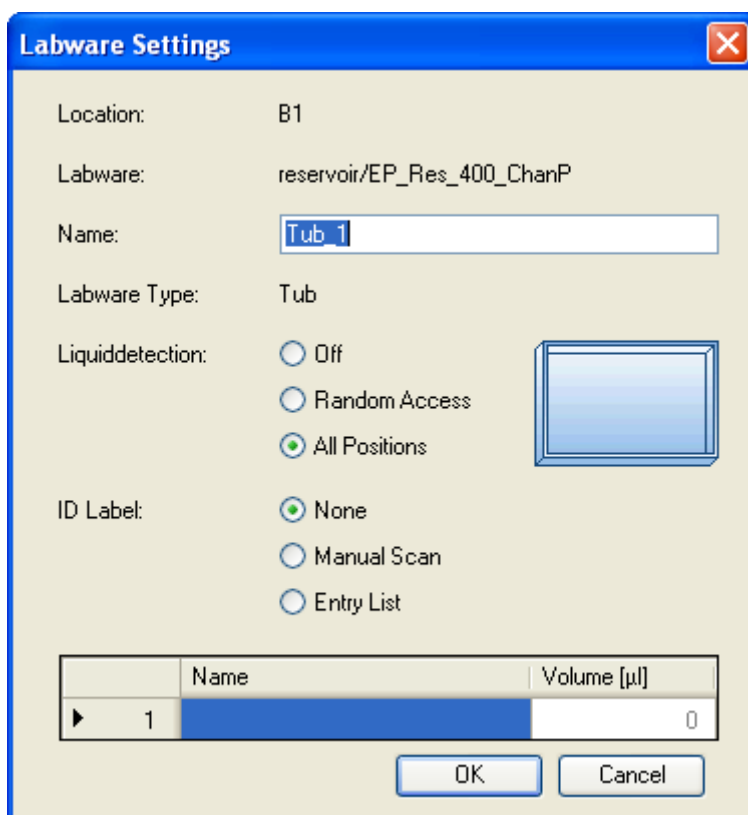
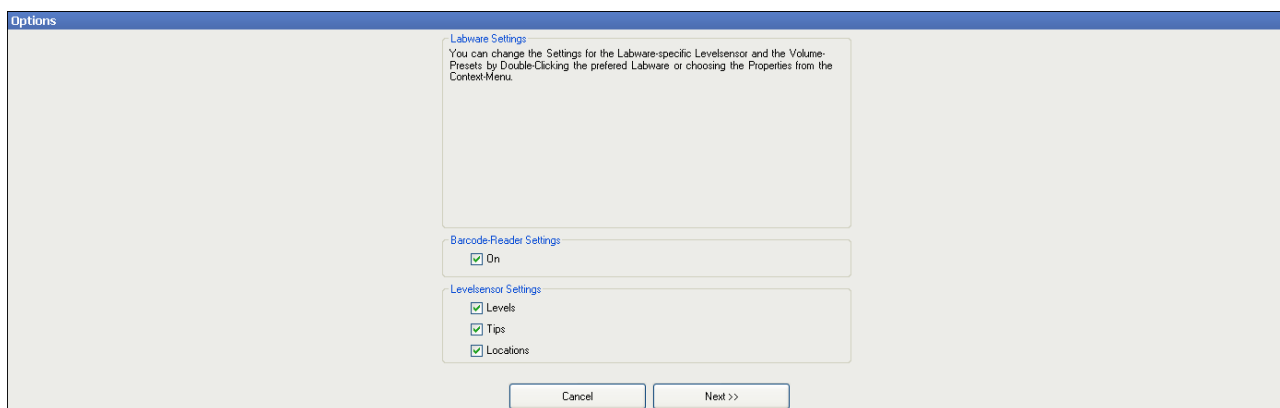

Fig. 43: Default setting of the optical sensor via the Functions tab

Double-click on the labware on the worktable to show the detection variants. In Worktable mode you can switch scanning of liquid surfaces on or off for any marked labware:



To switch scanning on or off for a specific run for all locations, activate the corresponding option immediately after starting the method.



If the filling volumes of the tubes are easy to detect in the method to be started, you can reduce processing time by switching off the optical sensor and entering volume manually. If destination tubes are empty, it is quicker to enter a volume "0" than to scan with the optical sensor. Filling volumes which are known should be defined when you edit the method.

If the optical sensor is switched off, a display for entering filling volume is automatically faded in as the method continues.

### 11.3.2 Detection version 1: detecting liquid surfaces

Level Detection applies generally for Liquid Detection in all labware. You switch Level Detection on or off when you start a method.

If *Levels* is activated, the surface of the liquid is scanned in the case of labware for which Liquid Detection is set to *All positions*. If *Levels* deactivated, there is no detection of liquid surfaces (liquid detection).

Liquid Detection relates to the labware. Liquid Detection switches the optical sensor for detecting the surfaces of liquids on or off. When detecting the surface of a liquid, the optical sensor can only detect approximately horizontal (plane) surfaces. The surface must be at  $90^\circ \pm 3^\circ$  in relation to the optical beam axis. If the curvature of the surface is too extreme as a result of the physical properties of the liquid, tube or tube geometry, the optical sensor can no longer detect the liquid level. In this case, the user must enter the volume.

It is not possible to detect filling levels in 384-well plates; it is recommended to only a limited extent for 96-well plates to minimize the time required. Where Number of Samples  $\leq 10$ , only *Off* and *All Positions* are displayed for selection.

#### Liquid Detection selection options

##### Off

If you set the optical sensor to *Off*, 24 individual volumes can already be defined for a 24-tube rack when editing, for example:

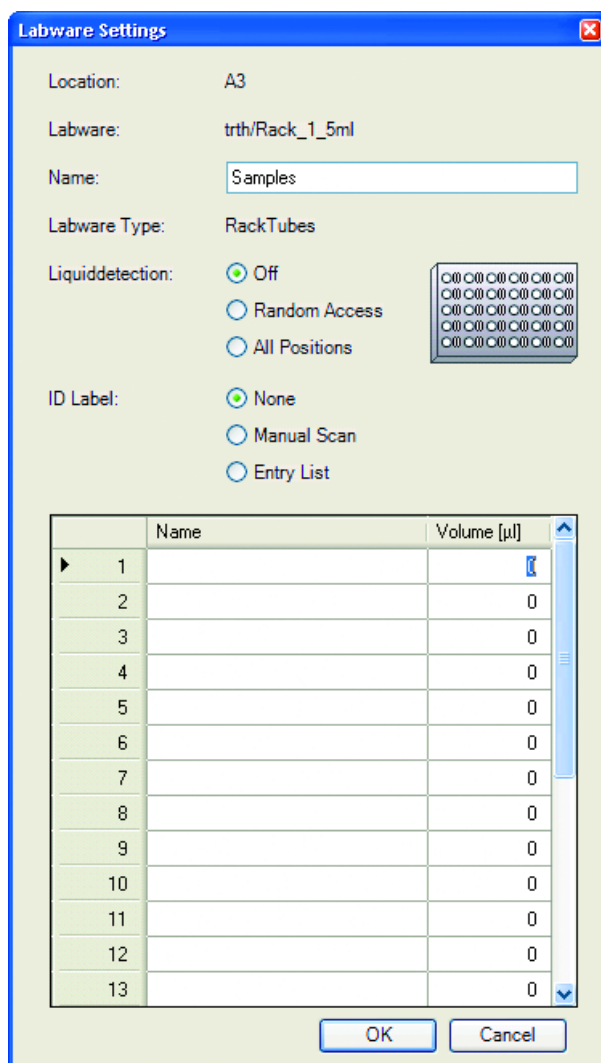

If you start with the volume entry in the first row, the volume will be adopted for all positions automatically. To do this, mark the *Volume* column and then click in another field. One correction per row is then possible.

For locations in which the optical sensor is switched off, the required volume is automatically displayed upon starting. The volume is displayed if the volume has been specified in the Worktable. Volumes can be corrected at this point. Empty destination locations are not automatically displayed to allow the volume to be checked and entered at the start of the method. If a volume is to be displayed automatically for destination labware at the start, enter a volume not equal to "0" when editing. If you are using the Rack 96 (two-location rack), you must make identical entries to the worktable for the two occupied locations.

### Random Access

Random access allows scanning for the first and last position plus 8 other random positions. Random access is recommended when tubes or wells have very similar filling levels within a location and the scanning procedure time is to be reduced.

Random access performs liquid detection only in positions which are defined via Number of Samples and Pattern. In the case of random access, the smallest volume determined is always used for all tubes or wells of a location for aspirating or dispensing the liquid. If there is a number of samples of 10 or less when the method is started, all the tubes affected are scanned by the optical sensor.

Notes: If filling levels differ significantly in one location, check whether the *Aspirate from bottom* and *Dispense from top* options are better alternatives to *Random Access*.

### All positions

If automatic detection is required, Liquid Detection must be marked with *All Positions*.

If all wells are scanned in a 96-well plate or 24-tube rack, each volume is administered separately when a single-channel dispensing tool is used.

In the case of eight-channel dispensing tools and a 96-well plate, the following applies: observe the largest volume within a column (8 wells) when dispensing liquid. Observe the smallest volume within a column (8 wells) when aspirating liquid.

### Optical sensor check run

If the optical sensor is unable to perform location detection successfully, you have the option of bypassing detection and entering the volume manually. To do so, mark *User input*. Check first whether the correct labware is positioned in the location. The method may not be continued if there is incorrect labware in the location.

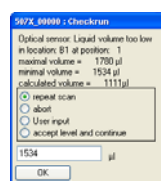

### Switch Level Detection on and off

If Level Detection is switched on and if variants for scanning the surface of the liquid are selected in the method for these locations, scanning is effected in the start routine.

If Liquid Detection for labware or Level Detection are switched off, all the volumes required are queried at the start.

Labware, that is in the virtual parking positions is excluded from Level Detection.

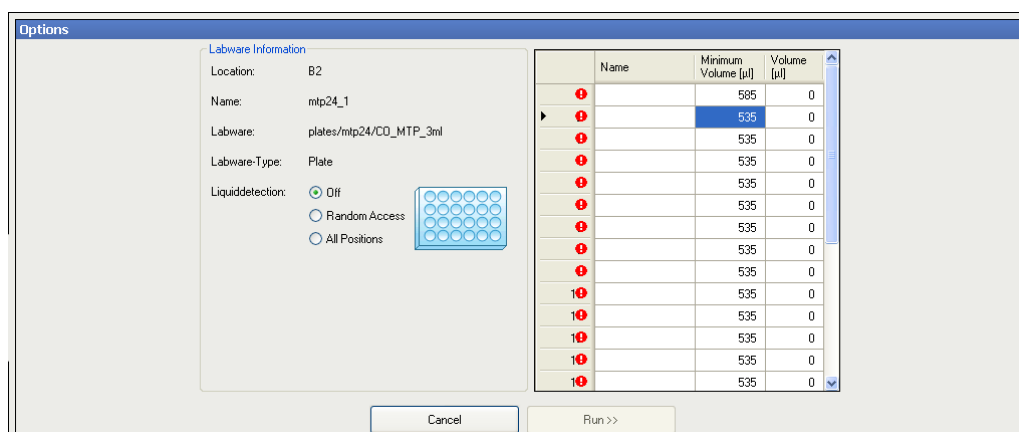

If you would like to specify the volume, exceed the specified minimum volume after the start. Make sure that you do not exceed the maximum volume. Once you have completed your input, press Enter. The entry should match the actual filling level of tube.

The specified volume does not take account of the way the shape of the meniscus of the liquid varies in the different tubes, for example. An inadequate volume could therefore lead to faulty dispensing.

At the start, it is possible to make an individual volume entry or volume correction for each tube in racks and reservoirs. With 96-well and 384-well plates, the one volume input applies to all wells.

Liquid Detection can be performed on a labware height up to 107 mm.

The optical sensor cannot be used for Liquid Detection in large tubes (e.g., 15 mL).

#### 11.3.3 Detection variant 2: Tip detection

Both the identity of the tip racks (volume range; with/without filter) in the locations and the presence of tips in the rack are detected. A code on the sides of the tip rack enables the tip type and supply quantity to be detected. If more tips are required for the method than are present, these extra tips are requested in the method once the existing tips have been exhausted. If tip detection is switched off, you will have to ensure that the tip rack is adequately supplied starting from the back left (coordinate A1) and that the specifications of the worktable corresponds to the method to be started.

#### 11.3.4 Detection variant 3: Location detection

A code in the corresponding racks enables correct occupation of a worktable location to be detected. Even racks positioned the wrong way round are detected, with the exception of reservoir racks. Plates are detected by height.

Location Detection can be performed on a labware height up to 107 mm.

### 11.3.5 Detection limits

Depending on tube geometry, there are different detection limits for the optical sensor when detecting filling level (liquid detection). Information about the detection limits can be displayed if you click on *Info* in the file window. So that aspiration can be performed from tubes with filling levels below the detection limit of the optical sensor, a volume must be entered at the start of the method. This entry can be made in the start routine using the keyboard, even after the relevant error message from the optical sensor. The detection limit of the optical sensor generally starts at filling levels above 3 mm.

Labware		Labware	Information
Labware-Type	Sub-Type		
Tips	DWP 384	96 CO_MTP_360_1 Corning/Costar 96 Well Plate Without Lids	<b>plates/mtp96/CO_MTP_360_1</b> *VendorInfo: Corning/Costar 96 Well Plate Without Lids Description: U-bottom, PP Order No.: 3365 Maximal filling volume: 270 µl Working volume: 200 µl Detection limit optical sensor: 70 µl Version: 1.0
Plates	DWP 96	96 CO_MTP_360_2 Corning/Costar 96 Well Assay Plate	
Equipped Racks and Modules	Filter Plates 384	96 EP_pDNA_96_MTP Eppendorf 96 Well Elution Plate with	
Equipped Holders	Filter Plates 96		
Adapter	MTP 24 + DWP 24		
Lids	MTP 384		
Vacuum Frames	MTP 6		
Thermoblocks with Plates	MTP 96		
Tubs	PCR 384		
	PCR 96		
	Tube Plates 96		

## 12 Appendix B: Software

### 12.1 Commands, parameters, options

This section includes detailed information about commands and parameters. This information is supplemented by the descriptions in the section entitled "Operation".

The parameters and options of the commands are described in detail in the section entitled "Sample Transfer". Parameters and options of individual commands which deviate from Sample Transfer are described separately.

#### 12.1.1 Number of Samples

Use the **Number of Samples** command to specify how many samples are to be processed in the subsequent steps of the procedure. It applies to all commands until the next **Number of Samples** of the procedure. If you do not enter this command, a question is asked about the number of samples when the device starts up. This entry then applies to all the commands of the method.

The maximum number for **Number of Samples** results, dependent on the command, from the plate or rack type in the destination or source vessel location. For example, the largest value for two 384-well plates is 768.

Further restrictions on the maximum number result from the pattern and the number of tubes per rack or wells per plate. For example, the sum of the aspiration locations in the source vessel location during **Sample Transfer** can be smaller than the sum of the dispensing positions in the destination vessel location.

Depending on the type and purpose of the subsequent commands *Number of Samples* has different effects:

- *Sample Transfer*: number of samples picked up by the source vessel plate.
- *Reagent Transfer*: number of wells of the destination vessel plate into which the reagent is dispensed.
- *Dilute*: number of samples to be diluted.
- *Pool* and *Pool One Destination*: number of wells in the source vessel plate from which liquid is aspirated.
- *Mix*: number of wells in the plate in which the liquid is mixed.

#### Define parameters

- *Fix Number of Samples*:  
Activate this option if a fixed number of samples is to be defined for each method start. At the start, there is **no** Number of Samples request.  
Deactivate this option if the number of samples is to be entered by the user when the method is started.

- *Max Number of Samples:*

At the start of the method, the number entered here is accepted as the maximum input value. When the pattern is displayed, *Max number of Samples* is taken into account.

- *Comment* is displayed at the start of the method and the *Number of Samples* request. The comment can provide information about which entries are meaningful here or to which commands the entry relates (e.g., maximum number of samples, to single-channel or eight-channel dispensing tool and Reagent or Sample Transfer).

*Fix Number of Samples* and *Max Number of Samples* both apply until the next *Number of Samples* command in the procedure.

The *Number of Samples* request is asked first at the start. If *Number of Samples* is contained several times in a procedure, the request occurs in succession as many times as required (exception *Fix Number of Samples*).

If part of a procedure in the method is not to be executed, enter "0" as a value.

### Information about entering Number of Samples

- **Eight-Channel Dispensing Tools**

Example of Number of Samples entries with an eight-channel dispensing tool:

An entry of "1" to "8" means that 8 "samples" will be processed. An entry of "9" means that 16 "samples" will be processed etc. This applies correspondingly to a 384 plate. Note that with a 384-well plate, only every other well in a column will be served by the eight-channel dispensing tool. Further procedure depends on the pattern.

- **Sample Transfer**

Example: a 96-well plate is to be filled by two full 24-position racks. For every rack the method contains a Sample Transfer command in which a rack has been defined as source vessel.

The **Number of Samples** command has been entered once. In order to transfer 24 samples to the plate from both the racks, enter the value "24". A total of 48 transfers is thus effected. An entry of 10 would mean that in each rack, the tool aspirates from 10 positions. The maximum number for Number of Samples is 24.

If both racks are to be processed consecutively, a Sample Transfer command with both racks as source vessel is defined in the method. An entry of 30 would then mean that the Sample Transfer would be carried out in full in the first rack (24 transfers) and six times in the second rack. The maximum number for Number of Samples is 48.

In order for the different execution options to be detected at the start, enter a comment on the Number of Samples when editing the method.

- **Reagent Transfer**

The entry of the Number of Samples for the Reagent Transfer relates to the destination vessel.

- **Dilute**

Number of Samples before the **Dilute** command defines the numbers of samples to be diluted. The dilution steps are defined in the pattern. Dilution steps are possible only within a location; they are limited by a row or column. In other words, with a 96-well plate, all the wells of one row can be filled with diluent and 12 dilution steps could be performed. In this case, the undiluted sample would be aspirated from another location in the first step.

- **Pattern**

Examples for limiting the Number of Samples by the pattern in a Sample Transfer: If only every second sample is aspirated from a 96 well plate (source vessel), the maximum input is: 48 ( $96 : 2 = 48$ ).

If one sample is aspirated from a 96 well plate (source vessel) and dispensed twice into another 96 well plate (destination vessel), then the maximum Number of Samples is 48.

Reason: Sample Transfer applies here from one source vessel to one destination vessel; here  $48 \times 2 = 96$  applies. If, however, a second 96 well plate was available in the command as destination vessel, the 96 samples could be transferred either continuously (first plate A complete, then plate B) or alternating (plate A, plate B, plate A, etc.). Whether the transfer is continuous or alternating is defined in the pattern of the method.

### 12.1.2 Sample Transfer

The command transfers samples from several locations of a source vessel plate to several locations of a destination vessel plate in accordance with the defined patterns.

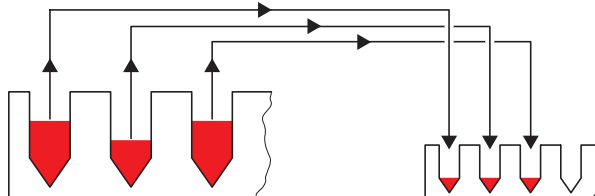

Fig. 44: Diagram of Sample Transfer

The number of samples picked up from the source vessel plate depends on the preceding command *Number of Samples*.



Barcode

The Sample Transfer command automatically carries out an ID tracking (transfer of IDs to the destination labware) when the source labware is provided with IDs.

### Define parameters

**Pipet.Tool** Select Dispensing Tool The name "TS" (tool, single channel) stands for single-channel dispensing tools while "TM" (tool, multi channel) stands for eight-channel dispensing tools. The selection depends on the tubes used and the volume. Eight-channel dispensing tools cannot be used with 24-tube racks, for example. When selecting the dispensing tool, be aware of immersion depth into the tubes.

**Filter Tips:** Define whether pipette tips with filters are used in the method.

**Volume** Enter the volume and select µL or nL. With volumes of up to 99.9 µL a decimal place is available.

**Transfer type** *Pipette:* Aspiration and dispensing of the volume entered.

*Multidispense:* Dispensing of the volume entered at every dispensing step. Number of steps and quantities aspirated depend on the Number of Samples.



With small volumes, pipetting always provides better free-jet capability as well as precision and accuracy. When pipetting, in contrast to multidispense, only the required volume is aspirated and dispensed. However, please note that multidispense represents a very rapid type of dispensing. With the multidispense option, a 96-well plate can be filled in 35 to 60 seconds.

However, with multidispensing the measurement errors identified for pipetting are exceeded (see *Dispensing Tools* on p. 159).

**Source and Destination:**

A selection is only possible if the worktable is already equipped with labware. When you press the *Source* or *Destination* buttons, displays with corresponding selection lists will become available. The selection is made using the labware positioned on the worktable. Up to four locations can be selected as source or destination vessels within a command.

After selecting the source and destination vessels the respective labware names are displayed. You can also dispense within a plate, in which case the source vessel and destination vessel are identical.

If the source or destination labware is deleted from the worktable, the labware name will be shown in gray in the parameter settings. The source labware or destination labware has to be defined afresh or an error message is issued when starting the method.

**Pattern:**

Define pattern. Patterns can be defined with automatic pattern detection, as simple standard patterns (Sample Transfer only) or free patterns (irregular). The patterns are independent of direction. Regular patterns are detected by the software after just a few entries, and completed without further entries.

If the labware is changed after the pattern has been entered, a corresponding warning sign appears when a new labware is selected. If the same tube type (e.g., MTP 96) is retained, the pattern can be adopted.

If no destination vessel is defined in the pattern in default pattern or in pattern with automatic sample detection, the software automatically completes the pattern in the direction of the rows (from left to right).

**Pattern with several plates as source or destination vessels**

If several plates are available as source vessels and/or destination vessels, the display pattern is expanded as follows:

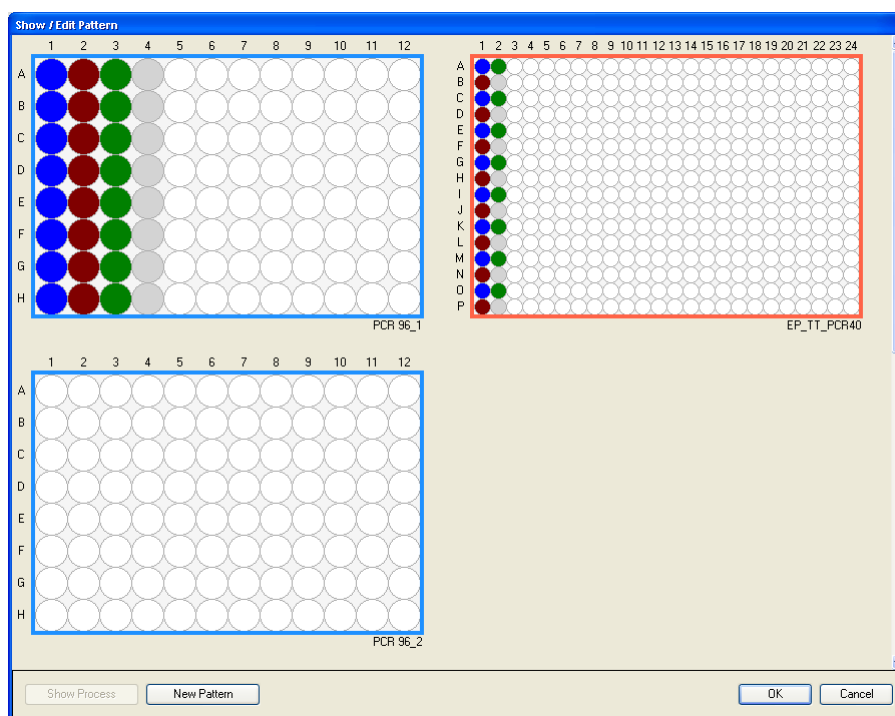

Begin entering the pattern with the top labware. The labware is displayed here in the order of the source or destination vessel definition. The source vessel is shown on the left, the destination vessel on the right.

If the same sample or liquid is to be transferred to specific wells of all plates following the same pattern, an entry for all plates in the *Source* or *Destination* display is only required for the first transfer. During the second transfer only an entry in the very first labware of the source or destination is required.

### Example pattern for several plates



Detailed descriptions on pattern can be found in the chapter "Operation" (see *Editing the pattern for a Transfer command on p. 70*).

#### Objective

One sample is to be transferred from a 24-tube rack in each case eight times to four 96-well plates. The pattern for one plate is also to apply to the other plates.

This example describes only the steps relevant to a pattern. It is assumed that the worktable has been loaded and commands and parameters have been specified.

1. Define the 24 well rack as source vessel.
2. Define the 96 well plates as destination vessel.

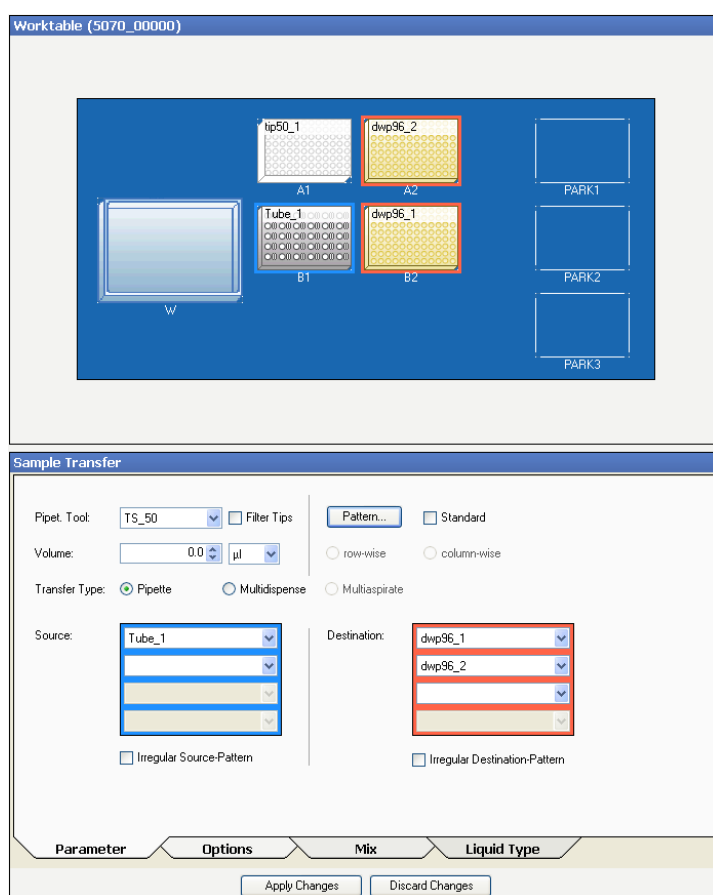

3. Define the pattern. To do so, define an aspiration location of the source vessel.

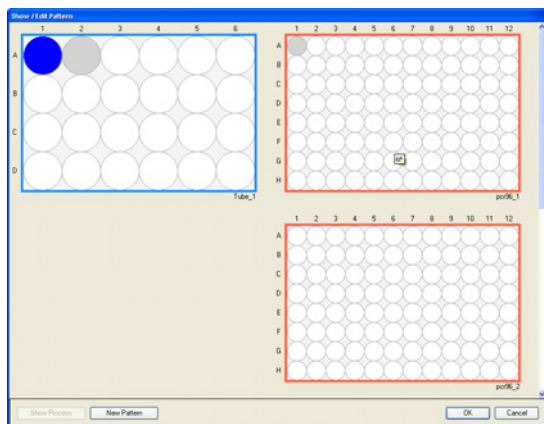

4. Define the dispensing positions of the destination vessel.

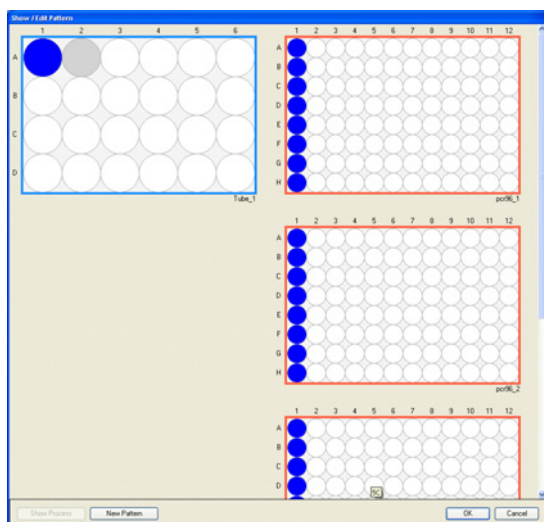

5. Click on the first well in the second plate.  
The entire column will be adopted in accordance with plate 1. Continue analog with additional destination vessels.
6. Complete the pattern. Subsequently the pattern for the destination vessel only has to be entered for the first plate. The pattern is transferred to all additional destination plates.

## Options

You can make further settings via *Options*.

### Immersion depth and dispensing height

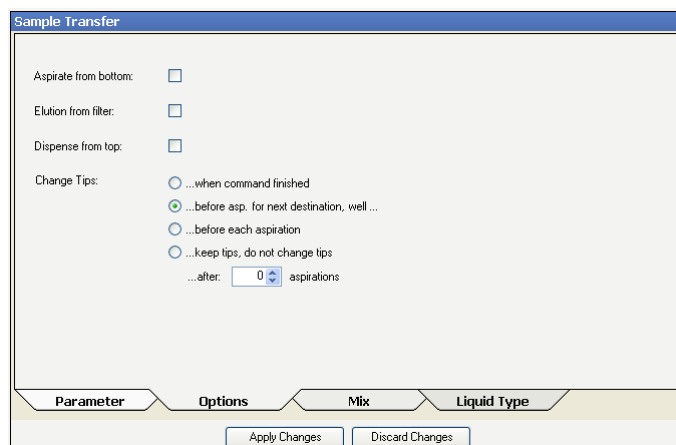

#### Aspirate from bottom

This version is especially recommended for smaller tubes. It is not necessary to scan MTP and PCR plates if the required volume is much smaller than the existing one.

At the start only enter a volume for the plate which approximately corresponds to the actual volume and allows for any aspirations and additions which may be required. The volume entered does not affect the position of the pipette tip with *Aspirate from bottom* or *Dispense from top*. To prevent tubes overflowing during aspiration, the level of the tubes must not exceed the working volume. With *Aspirate from bottom*, the tip is positioned approx. 1 mm above the bottom of the tube. The distance from the bottom of the tube depends on the tolerances of the tube type and can be modified by the administrator. After liquid has been aspirated, the tip is moved slowly out of the tube.

*Aspirate from bottom* is not recommended for tubes > 3 mL with high filling levels. In the case of viscous solutions, the outer wetting which results may increase the risk of contamination and falsify the dispensing result.

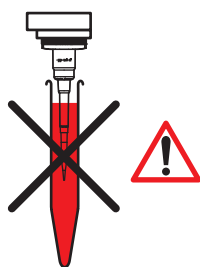

With very large tubes (e.g., centrifugation vessels or reservoirs) and high filling levels it is even possible for the entire tip and the tip cone of the dispensing tool to become wet. You should always avoid high filling levels.

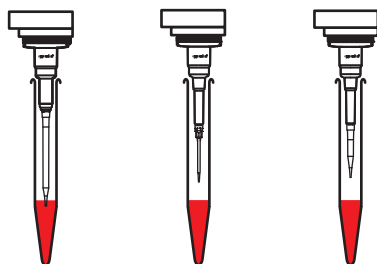

With large tubes, the length of the 50 µL and 300 µL tips and the dispensing tool result in restrictions on immersion depth, leading to a higher remaining volume compared to the 1000 µL tip.

**Dispense from top** *Dispense from top* is a fast version for dispensing a liquid into a destination vessel, because the z movement up to approx. 3 to 4 mm above the liquid prior to dispensing is omitted. Liquid is dispensed in the top area of the tube. The tubes may not be filled above maximum filling volume. *Dispense from top* can also be used for pipetting and on smaller tubes or plates with different filling levels. As the tip remains in the top area of the tube and does not move down into the tube, the risk of contamination is virtually ruled out. The greater distance from the liquid may impair target accuracy at minimal dispensing volumes. With a small volume and tubes > 5 mL, the tip might not reach the bottom of the tube or the liquid provided. There is a risk of the liquid touching the tube wall above the liquid provided. With larger volumes, liquid could well splash up. Certain dispensing speeds may not be exceeded for acceptable dispensing. *Dispense from top* should be validated by corresponding trials.

**Elution from filter** This function is especially suited to the aspiration of liquids from corresponding filter plates (currently only PCR cleanup filter plates). The following special features apply to this option:

- Do not enter a volume for Sample Transfer.
- The piston movement in the dispensing tool for aspirating liquid starts as soon as the tip starts moving down in the well. The maximum stroke is used for each dispensing tool. This also applies to dispensing.
- The tip travels easily into the resilient filter material.
- In combination with the test PCR cleanup a *Mix before aspirating* is recommended.
- The *Elution from filter* function relates to the source vessel.

With the elution function, virtually complete aspiration of the liquid from the filter plate is achieved.

- In the Sample Transfer command under *Transfer Type* select *pipette*.
- The aspired liquid is dispensed into the destination vessel.

When transporting the liquid, the usual appearance of the liquid in the pipette tip does not apply. There may be air bubbles at several points in the pipette tip. The air segment at the bottom end of the pipette tip may not be clearly pronounced.

At different volumes you save time if the optical sensor is not used to determine liquid level. However, selecting *Aspirate from bottom* and *Dispense from top* ensures that liquids are dispensed and professionally dispensed. You are still asked at the start to enter a volume for a plate with 96 wells (exception: destination labware which had a volume "0" when the worktable was edited). The intention is to select an average volume for all wells with *Aspirate from bottom* or *Dispense from top*.

### Changing pipette tips (Change Tips)

Under *Options* you can determine the time when tips are changed.

The following is displayed:

*Change tips ...*

- ... *when command is finished*

The tips are not ejected until the command is finished. This is recommended in the case of repeated aspiration of a particular reagent for filling all the wells of a plate, for example.

- ... *before asp. for next destination, well*

Tip change before aspirating from a new location. If many different liquids are aspirated from a plate or rack, the new liquids must not come into contact with old remaining liquid in the tip. Tip change is therefore advisable.

- ... *before each aspiration*

No tip is filled twice, Even if it is the same source vessel for the aspiration. Should always be used for *Mix after dispensing* to prevent contamination of the source with liquid traces from mixing in a destination vessel.

- ... *keep tips, do not change tips*

The tips continue to be used in the next command. If the next command is likewise defined with *keep tips, do not change tips*, use also continues to the command after next and so on (sensible if a nutrient medium is to be distributed on many empty plates, for example). Particularly with liquid which tends to foam, failing to change tips after multiple aspirations can lead to extra volume in the tip. This extra volume may cause contamination of the dispensing tool. If transfer type *pipette* is changed to *multidispense*, after the first command an ejection occurs even if *keep tips, do not change tips* is selected.

- ... *after: aspirations* In the input field you can set the number of strokes after which the tips should be ejected. This function is available if ... *keep tips, do not change tips* has been selected.

**Special features of multidispense:**

With *multidispense*, a slight extra volume needs to be aspirated.

- ... *before asp. for next destination, well:*
  - Extra volume is returned into the old source vessel
  - Change tip
  - Liquid aspiration from new source vessel
- ... *before each aspiration:*
  - Extra volume is discarded into the waste
  - Change tip
  - Liquid aspiration from new or old source vessel

## Mix

### Mix before aspiration or after dispensing

If *Mix before aspirating* and/or *Mix after dispensing* is selected, a display for setting mixing parameters appears when you click on the adjacent button.

The screenshot shows the 'Sample Transfer' dialog box with two columns of settings. The left column is for 'Mix before aspirating' and the right column is for 'Mix after dispensing'. Both columns have identical settings: No. of Cycles (2), Speed (11.0 mm/sec), Volume (0.0 µl), Fixed Height (unchecked), Aspiration (0 mm), and Dispense (0 mm). At the bottom, there are tabs for 'Parameter', 'Options', 'Mix', and 'Liquid Type', and buttons for 'Apply Changes' and 'Discard Changes'.

If *Fixed height* is **not** selected, the following applies:

- The settings for immersion depth, blow-out (to aspirate the remaining liquid), delay time to start blow-out, etc. are automatically taken from the selected liquid type.
- If *Aspirate from bottom* has been selected, this immersion depth also applies to *Mix before aspirating*.
- If *Dispense from top* has been selected, the volume known at the start will be used for mixing in conjunction with the *Liquid type* immersion depth for *Mix after dispensing*.

Unlike with all other forms of dispensing (free flow) in dispensing with mixing there is contact with the liquid in the destination vessel. Particular note should be taken of this when setting tip change.

Mixing volume is always less than the current filling volume in the tube, as the remaining volume of the aspiration cannot be used for mixing. The remaining volume for the correspondingly marked tube may be viewed in the *Labware properties* section via the *Open a labware* window, for example. In the case of very large tubes (e.g., conical tubes) larger remaining volumes result with the 50 µL and 300 µL tips in combination with the geometry of the dispensing tool than with the 1000 µL tips.

In the case of deviations from the predefined liquid type, determine the optimum mixing speed in trials. Carefully increase the mixing speed during these trials. Use very high speeds only for correspondingly viscous solutions. At very high speeds, large volumes and multiple mixing cycles, liquid may get into the dispensing tool (e.g., foam formation). The use of filter tips will increase reliability.

The entire mixing process takes place in the liquid. When the liquid is aspirated and dispensed, the dispensing tool is moved on accordingly in the z direction. Blow-out is performed at the end above the liquid. A mixing cycle consists of an upward and a downward movement.

The *Mix after dispensing* mixing variant can only be used in conjunction with the *Pipette* dispensing variant.



More information on mixing is provided separately.

---

## Liquid types

If liquids whose physical properties of viscosity, vapor pressure and surface tension differ significantly from those of water are to be dispensed, we recommend selecting a different liquid type. The predefined liquid types are arranged to work at a consistent immersion depth for aspiration. During aspiration, the dispensing tool moves on to suit aspiration speed, tube geometry and aspiration volume.

Check every selected liquid type and every parameter change in conjunction with other commands by test-running the method. The predefined liquid types represent recommendations. If necessary, adapt the settings to your requirements.

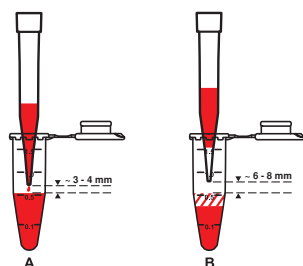

### A Dispense

Dispensing is effected approx. 3 to 4 mm above the liquid. During dispensing, the tool moves up so that the gap is maintained. Exception: liquid type "ProteinC" at 5 mm

### B Drawing-up following aspiration

Before the liquid is transported, the liquid is drawn up in the pipette tip so that the bottom part of the tip contains air during the transport operation.

The following liquid types are available:

Liquid Type	Dispensing data optimized for	50 µL tip: pipetting from	50 µL tip: dispensing from	Comments
<i>Alcohol 75%</i>	Mixture of 75% ethanol and 25% water	1 to 3 µL	3 µL	Wash reagent in kits for nucleic acid purification. See applications in ep-Folder <i>Nucleic acid prep</i> . <i>Speed Aspiration</i> : low to medium <i>Speed Dispense</i> : low to high
<i>Alcohol 98%</i>	Alcohol 98%	1 µL	3 µL	A new tip is prewetted with the liquid for aspirating. <i>Speed Dispense</i> : low Only for multidispense using 300 µL filter tips: very small gap from filter with 300 µL aspiration. To prevent the filter from being wetted, default to pipetting from 280 µL.
<i>Glycerol</i>	Mixture of 40% glycerin and 60% water	1 µL	5 µL	Glycerin content in many enzyme solutions is much less than this, so <i>Water</i> can also be used as the liquid type here. <i>Speed Aspiration</i> : medium <i>Speed Dispense</i> : medium to high; ZN 300-8:low
<i>Protein</i>	Water with 1% albumin (10 g/l), 0.01% Triton X-100	5 µL	5 µL	When using a new tip, prewet it with the liquid to be aspirated before the first dispensing operation. Notice! Curvature of the liquid surface will impair free-jet capability when dispensing into cell culture plates. See <i>ProteinC</i> . <i>Speed Aspiration</i> : low to medium <i>Speed Dispense</i> : low to medium

Liquid Type	Dispensing data optimized for	50 µL tip: pipetting from	50 µL tip: dispensing from	Comments
<i>ProteinC</i>	As for Protein	As for Protein	As for Protein	<i>ProteinC</i> uses when dispensing higher distance to the calculated plain liquid surface (4 to 5 mm) than <i>Protein</i> . All other data such as <i>Protein</i> . Recommended for nutrient media. <i>Speed Aspiration</i> : low to medium <i>Speed Dispense</i> : low to medium
<i>Rinse</i>	For demineralized water and water with a low surfactant content; use the <i>mix</i> option or independent <i>MIX</i> command	1 µL	3 µL	Like the <i>Water</i> liquid type but with a significantly delayed blowout. Recommended, e.g., in combination with <i>mix</i> to reduce the residual moisture in the tip, but it can also increase the contamination risk regarding smaller containers (e.g., wells in PCR plate). <i>Speed Aspiration</i> : medium <i>Speed Dispense</i> : medium
<i>Speed_xl</i>	Demineralized water; mixed by means of high dispensing speed	1 µL	3 µL	Thorough mixing in a 96-well DWP, for example, with a 750 µL sample and 750 µL dispense. Caution! Higher risk of contamination, especially with small tubes, because of high dispensing speed! <i>Speed Aspiration</i> : medium <i>Speed Dispense</i> : medium to high
<i>Speed_xs</i>	Demineralized water; very low aspiration speed to avoid stirring up sediment	1 µL	3 µL	E.g., for slow aspiration from filter plates. <i>Speed Aspiration</i> : very low <i>Speed Dispense</i> : medium
<i>Water</i>	Demineralized water	1 µL	3 µL	Technical data relating to systematic and random measuring deviation was determined using this liquid type. Recommended for most methods. <i>Speed Aspiration</i> : medium <i>Speed Dispense</i> : medium

### Change parameters of the liquid type

The screenshot shows the 'Sample Transfer' software interface. At the top, 'Standard Liquid Type:' is set to 'Water' with a dropdown arrow and the word 'default' to its right. Below this is a checked checkbox labeled 'Change Parameter'. A list of parameters follows, each with a numerical input field and a unit: 'Speed Aspiration:' (11.0 mm/sec), 'Speed Dispense:' (15.4 mm/sec), 'Delay Blow:' (0 ms), 'Speed Blow:' (33.0 mm/sec), 'Movement Blow:' (0 % of max. movement), 'Initial Stroke:' (100 % of max. stroke), and 'Prewetting:' (0 Cycles). A 'Set Default' button is located to the right of the 'Prewetting' field. At the bottom, there are four tabs: 'Parameter', 'Options', 'Mix', and 'Liquid Type', with 'Liquid Type' being the active tab. Below the tabs are two buttons: 'Apply Changes' and 'Discard Changes'.

The first time the display is called up, the standard parameters specified in the software for the previously-selected liquid type, the previously-entered volume and the previously selected dispensing type are displayed. This is indicated by *default* in the top right of the display. In the event of changes, the display changes from *default* to *changed*. The liquid type can be reset to the default parameters at any time with the *Set Default* button.

The variation of *Movement Blow*, *Speed Blow* and *Delay Blow* serves to optimize the dispensing of remaining liquid.

Tab. 3: Liquid Type Parameter

Parameter	Input range	Comments
<i>Speed Aspiration</i>	0.2 to 110 mm/sec	In the case of viscous solutions and relatively large aspiration volumes, <i>Speed aspiration</i> should be increased only moderately so that the delayed aspiration of liquid can be completed before the z movement of the carrier. Low values are meaningful for phase separations, for example, or to avoid stirring up sediments or particles.
<i>Speed Dispense</i>	0.2 to 110 mm/sec	Especially when dispensing relatively large volumes into an empty tube, the risk of liquid splashing back can be reduced by lower <i>Speed Dispense</i> values. At higher values, be aware of the increased risk of contamination from the liquid splashing out. Higher values are meaningful, for example, when dispensing into a relatively large tube to achieve more thorough mixing.
<i>Delay Blow</i>	0 to 99990 msec	With liquids which have higher wetting properties and consequently delayed draining characteristics, we recommend increasing <i>Delay Blow</i> . The time can be set to zero for liquids which do not wet very much. Increasing <i>Delay blow</i> means that the method takes longer.
<i>Speed Blow</i>	0.2 to 110 mm/sec	The term <i>Blow</i> is used to describe the blow-out like with a manual pipette. At lower values for <i>Speed Blow</i> , bubbles may form at the outlet opening of the pipette tip in liquids with low surface tension.
<i>Movement Blow</i>	0 to 100%	Extent of piston stroke in the blow-out step. This is slightly different depending on dispensing tool. <i>Speed Blow</i> and <i>Movement Blow</i> can be varied with the objective of reducing the splashback of the liquid to be dispensed or the liquid already in the tube.
<i>Initial Stroke</i>	0 to 100%	Extent of piston when blowing out air after completed absorption of liquid. With changes of <i>Initial Stroke</i> the tips are changed automatically due to technical reasons.
<i>Prewetting</i>	0 to 9 cycles	Prewetting is carried out only with a new unused tip in order to create the same conditions for the first and for subsequent dispensing steps. It is recommended for liquids with a low vapor pressure to enrich the air space in the dispensing tool with evaporated liquid to a comparable extent in all cases. It is also recommended for liquids with reduced surface tension and consequently delayed draining properties so as to achieve comparable prewetting of the tip with solution for all dispensing steps. Prewetting (1 cycle) is preset with the liquid types <i>Alcohol 98%</i> , <i>Protein</i> and <i>ProteinC</i> .



If the optimal setting of *Initial Stroke* is changed, it may lead to cross contamination.



Changes in the liquid types are carried out at one's own responsibility and can possibly lead to a deterioration of the dispensing results.

Please check the setting regarding the dispensing accuracy for each application.

The speed of liquid aspiration, liquid dispensing, drawing up and blow-out are optimized for the liquid in question in each liquid type in order to achieve low-contamination dispensing up to the working volume of the tubes.

With critical liquids, start checking with demineralized water. If this is successful, repeat the test with the liquid actually envisaged.

The following must be confirmed in the check:

- Adequate precision and accuracy are still achieved.
- No liquid splashes out (probability of contamination remains unchanged at low).

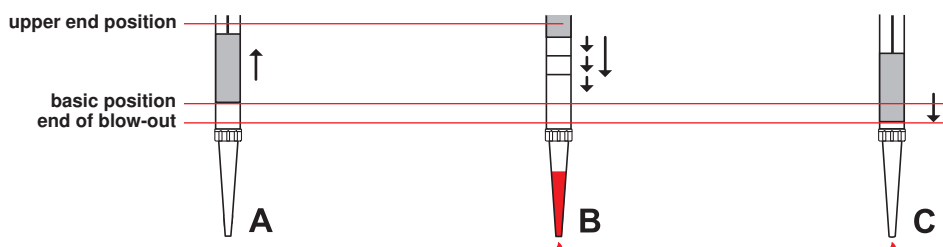

Fig. 45: Aspirate, dispense and blow

<p><b>A Aspirate</b> To aspirate a sample, the piston moves upward from the home position.</p>	<p><b>B Dispense</b> <b>Multidispense:</b> return to default position by means of short individual steps. <b>Pipette:</b> total path in one step.</p>
<p><b>C Blow</b> Remaining liquid is discarded by means of blow-out.</p>	

### 12.1.3 Reagent Transfer

A reagent is transferred from a source labware location to several destination labware locations. Reagent Transfer is best suited to transferring a reagent to several plates.

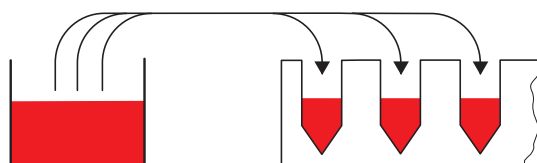

Fig. 46: Reagent Transfer principle

In Reagent Transfer the entry for Number of Samples relates to the destination vessel. All other entries and selection options are comparable to those of Sample Transfer.



In Reagent Transfer several source vessel locations with liquid might be present.



Barcode

ID tracking does **not** take place with the Reagent Transfer command. If the source vessel labware is provided with IDs, these IDs are only recorded in the log.

### Special case: use of several sources

For Reagent Transfer you can define methods in which more than one tube is defined as source vessel. The software can access the next tube automatically after the first tube has been emptied, to fill the destination labware for example. You no longer have to fill the first tube completely.

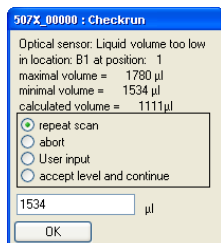

If the optical sensor is switched on, the first source vessel is scanned. If, during this process, the software detects that there is too little liquid for the number of samples, the *Checkrun* window will appear. The minimum volume, maximum volume and calculated volume are displayed. You can now select how the optical sensor is to proceed (continue, abort, etc.).

To incorporate the next tube in the calculation, select *accept level and continue*. The optical sensor continues by scanning the next tubes. The volumes determined are totaled and the method started when the volume is adequate.

The optical sensor also detects empty tubes that have been defined as source vessels in the pattern. *The message appears with a Calculated volume of 0 µL*. Confirm with *Accept level and continue* to scan the subsequent tubes.

If the level detection is switched off, a request for entering the volume appears for the source vessel locations of the pattern. The total volume required is assigned only to the first tube in the entry list. For all other source vessel locations the left-hand column contains "1". The "1" serves as a reminder to assign the individual volumes to the tubes.

### 12.1.4 Dilute

Dilute facilitates the creation of dilution series. A defined volume is transported from well to well by means of pipetting. Before the **Dilute** command diluent (diluent reagent) must be dispensed using a Reagent Transfers. The Reagent Transfer command fills the wells with the diluent required. Dilute can be executed using a source plate (undiluted samples) and a destination labware (dilution steps).

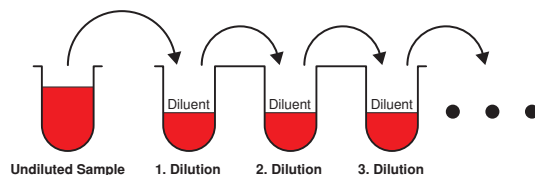

Fig. 47: Dilute command principle (destination vessel plate)

The **Number of Samples** command before Dilute defines the numbers of samples to be diluted. The dilution steps are defined in the pattern and only possible within one location. They are limited by a row or a column.

If the Dilute command is executed within a single plate, the source and destination vessel areas on the plate must not overlap. This can be achieved by limiting the number of samples with the *Number of Samples* command.



Barcode

The Dilute command automatically tracks the IDs (transfer of IDs to the destination labware) when the Dilute command is executed over different source and destination labware and the source labware is provided with IDs.



To achieve thorough mixing of sample and diluent, under *Mix* you should use *Mix after dispensing*. Mixing is performed after every dispensing step. *Mix before aspirating* refers only to mixing before the first aspiration, i.e. mixing the undiluted sample. All other entries and selection options are comparable to those of Sample Transfer.

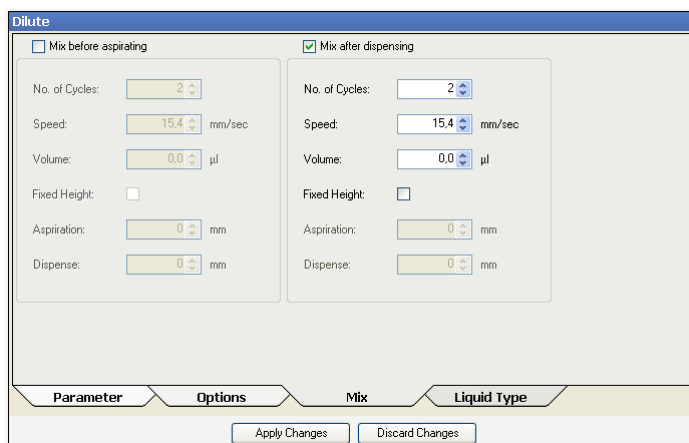

### Example dilution series

This example explains the principle of a dilution series. This is not a concrete application.

#### Sequence and objective of a dilution series

- 24 samples are in a rack with 24 vessels and should be diluted 1:1000.
- Dilution takes place in 3 stages with 1:10 dilutions in each case.

To achieve this, the 24 samples are transferred to a 96-well plate.

Diluent is transferred from a 300 mL reservoir to the 96-well plate.

Work is performed first with a single-channel dispensing tool and then later, to speed up the process, with an eight-channel dispensing tool.

#### Method

First samples and then diluent should be transferred to the 96-well MTP. The dilutions are performed in the MTP 96.

In the *Sample Transfer* command, 200 µL of sample are respectively put in the micro test plate. The pattern for the 24 samples in the destination vessel looks as follows:

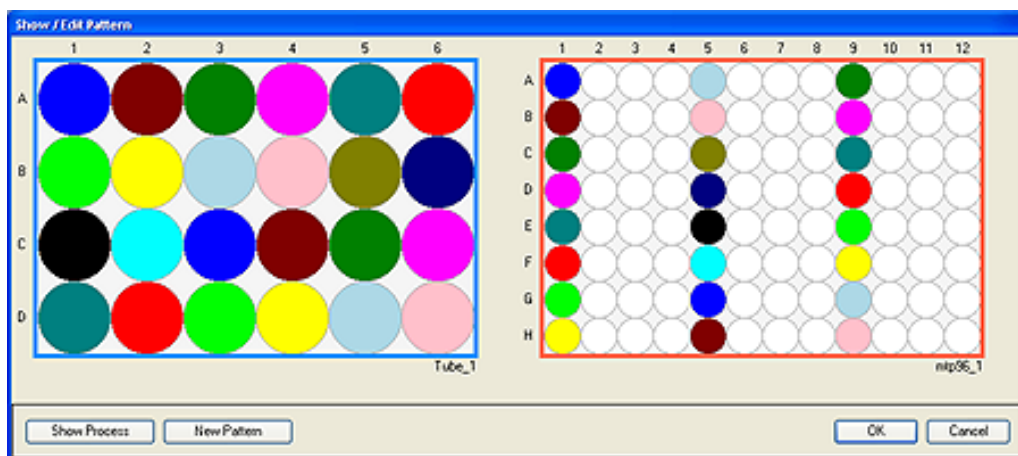

In the *Reagent Transfer* command the empty wells of the micro test plate are filled with 225 µL of diluent. From this point on, an eight-channel dispensing tool executes the task.

The pattern of the destination vessel looks as follows:

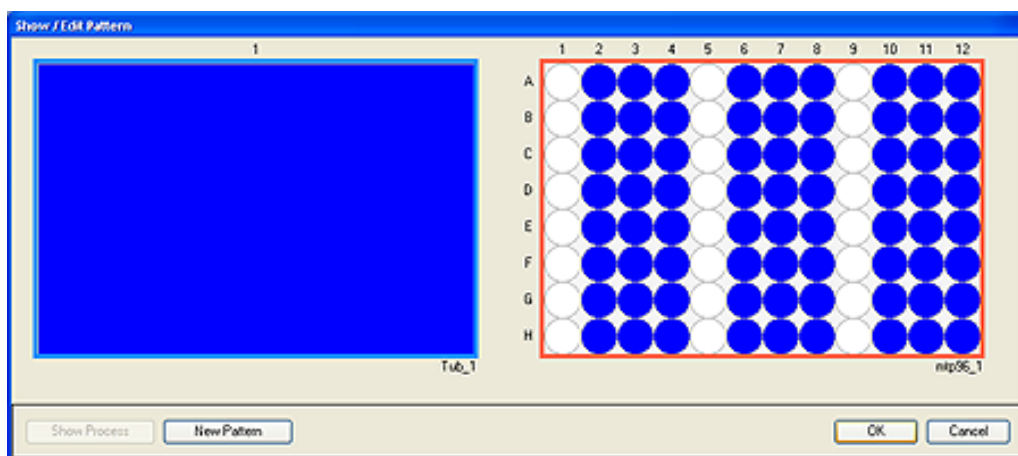

In the *Dilute* command 25 µL of sample (A-1) is aspirated and mixed with the 225 µL of diluent (e.g., A-2). This is performed three consecutive times (A-3 and A-4). These three dilutions (1:10) lead to a 1:1000 dilution (MTP columns 4, 8 and 12).

Calling up *Show Process* in the *Dilute* command must show the following pattern for Dilute:

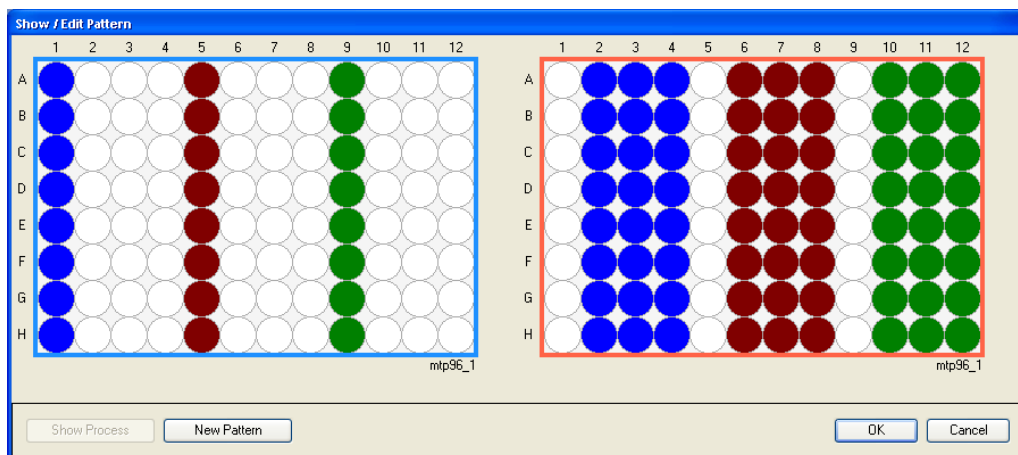

In this example, each dilution step is a 1:10 dilution. The desired dilution of 1:1000 is achieved using the third 1:10 dilution. The volume aspirated from the undiluted sample also applies for the dilution steps.

### 12.1.5 Pool

With the Pool command you combine liquids from several wells as well as different source vessel locations.

Because with *multiaspirate* following each sample aspiration a drawing-up of the liquid in the tip occurs, the aspirated liquid segments are in the beginning separated by air bubbles. With a filled tip the content is dispensed into the destination vessel. Which locations of the source are pooled for one location each of the destination vessel is defined in the pattern.

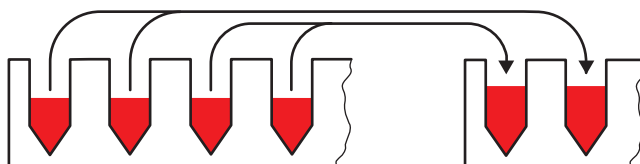

Barcode

The Pool command automatically carries out an ID tracking (transfer of IDs to the destination labware) when the source labware is provided with IDs.

### Define pattern

The pattern for the Pool command differs slightly from the pattern for other transfer commands. The following steps briefly describe the special features of the Pool command.

1. In the parameter window of the command click on the *Pattern* button.
2. In the pattern window click on the source locations from which the liquid is to be pooled in the desired order.
3. In the destination vessel plate click on the location where the pooled liquid is to be dispensed.
4. In the source click on the next sequence of locations from where the liquid is to be pooled.
5. In the destination click on the next location where the pooled liquid is to be dispensed.

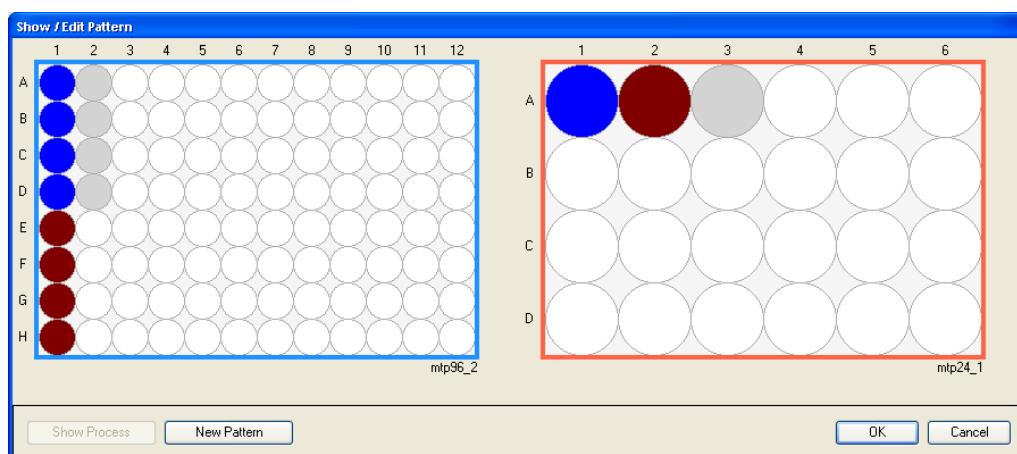

6. As soon as the pattern is identified, confirm with the *Ok* key.

## Options

### Change tips

#### Change tips ...

- .... before asp. for next destination, well ...

Is the default setting. Tips are only changed when the next pool has been assembled for the next destination location.

All other entries and selection options are comparable to those of Sample Transfer.

### Enter Number of Samples for Pool

The entry of the Number of Samples relates to the source vessel. The number of samples divided by "Number of Samples per Destination" gives the number of destination locations. If a decimal place results from the division, the number is rounded up for destination locations. The pattern in the source is also executed completely for the last destination location. In the Pool pattern, a maximum of the samples occurring in a row or column can be pooled.

**Example:** the samples of each column of a 96-well plate are to be pooled in a destination vessel. In other words, 8 samples are always put into a tube.

- Number of Samples entry at start: 48

$$48 : 8 = 6$$

6 destination vessels are filled.

- Number of Samples entry at start: 50

$$50 : 8 = 6.25$$

7 destination vessels are filled.

The command is executed in the source up to location 56 inclusive (prerequisite: no limit in the **Number of Samples** command).

#### 12.1.6 Pool One destination

With the PoolOneDest command you dispense the liquids from several source vessel locations into **one** destination vessel location.

The Number of Samples entry determines the number of locations in which aspiration will be performed. There is only one location as destination vessel.

With the multiaspirate transfer type, the liquid is drawn up in the tip following every dispensing step. The same criteria apply here as to the Pool command.



Barcode

The Pool One Destination command automatically carries out an ID tracking (transfer of IDs to the destination labware) when the source labware is provided with IDs.

## Define pattern

The pattern for the Pool One Destination command differs slightly from the pattern for other transfer commands. The following steps briefly describe the special features for the Pool One Destination command. In the pattern the locations are defined for the source vessel where aspiration is to take place and the direction of the aspiration steps. Next the destination vessel is only selected once.

1. In the parameter window of the command click on the *Pattern* button.
2. In the pattern window click on the first and the second source vessel location to define the direction for pooling the liquid.
3. In the destination vessel plate click on the location where the pooled liquid is to be dispensed.

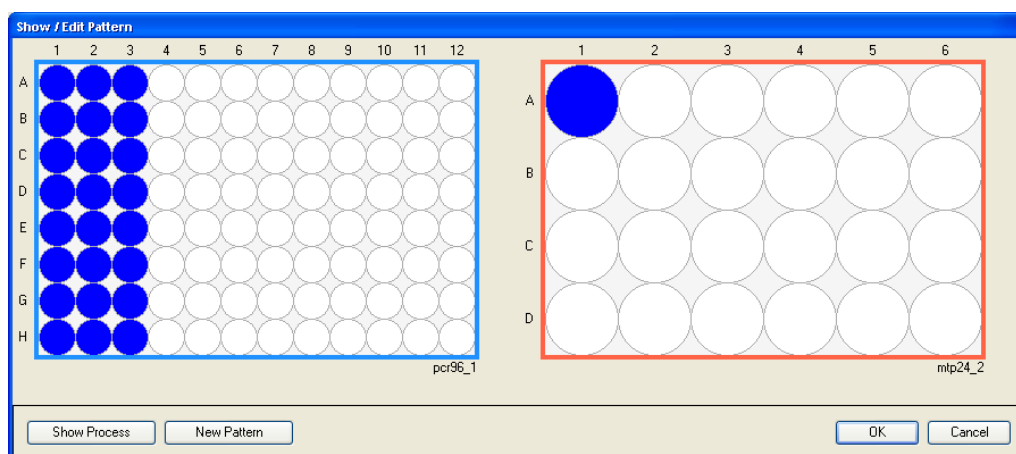

4. As soon as the pattern is identified, confirm with the *Ok* key.

## Options

### Change tips

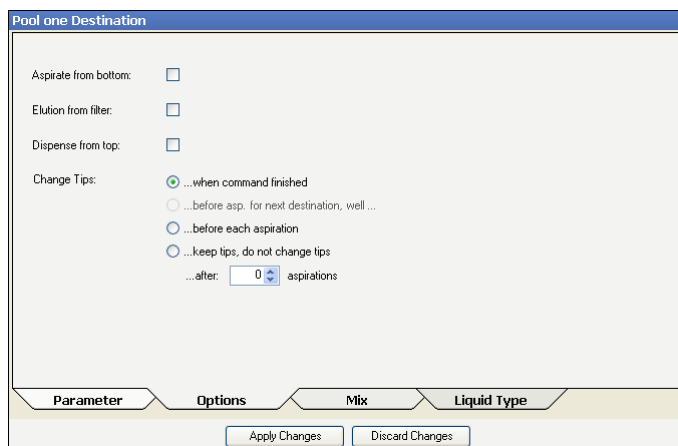

#### Change tips ...

- *... when command is finished*

Is the default setting. The tips are not ejected until the command is finished.

All other settings are comparable with Sample Transfer.

### 12.1.7 Mix

Use this command to mix liquids within a location.

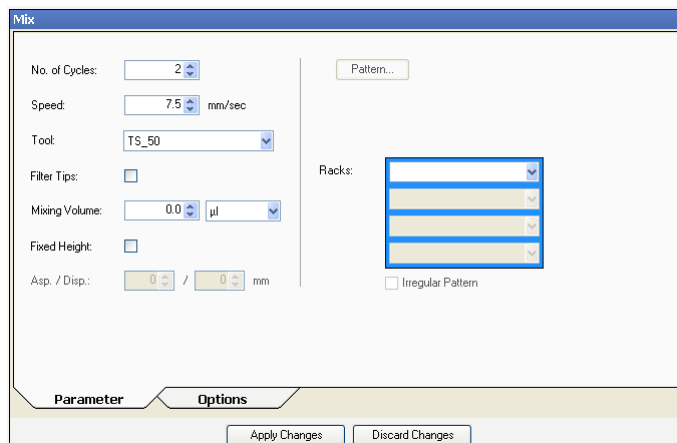

The entire mixing process takes place in the liquid. When the liquid is aspirated and dispensed, the dispensing tool is moved on accordingly in the z direction. A mixing cycle consists of an upward and a downward movement. The travel results from the selected volume.



Use only 50 µL tips for mixing in 384-well plates!

The descriptions of the mixing process for Sample Transfer (see *Mix on p. 201*) also apply to this stand-alone Mix command.

#### Recommended mixing speeds (Speed)

Enter the mixing speed in the *Speed* window. The speed range is between 0.2 and 110 mm/sec. As long as there is no entry in the input field for *Speed*, this field always displays the aspiration speed of the selected liquid type. The speeds in the Liquid Type parameters are optimized for pipetting or multidispensing in combination with the selected dispensing tool and the selected volume.

Dispensing tool	Recommended lower volume range (mm/sec)	Recommended medium volume range (mm/sec)	Recommended high volume range (mm/sec)
TS 50	15 - 88	15 - 44	10 - 40
TM 50-8	15 - 88	15 - 44	10 - 40
TS 300	5 - 15	6 - 16	6 - 16
TM 300-8	2 - 11	2 - 11	2 - 11
TS 1000	4 - 15	4 - 15	4 - 15
TM 1000-8	4 - 15	4 - 15	4 - 15

The optimum mixing speed should be determined in trials. Increase mixing speed carefully during these trials. Use very high speeds only for correspondingly viscous solutions.



At very high speeds, large volumes and multiple mixing cycles, liquid may get into the dispensing tool (e.g., foam formation). In this case, perform run tests using demineralized water. The use of pipette tips with filter will increase reliability.

## Mixing volume

The mixing volume must always be less than the current filling volume in the tube, as the remaining volume of the aspiration cannot be used for mixing.

You can have the remaining volume displayed in the *Labware properties*. In the case of very large tubes (e.g., 15 mL) larger remaining volumes result with the 50 µL and 300 µL tips in combination with the geometry of the dispensing tool than with the 1000 µL tips.

## Mixing functions at Fixed Height

With *Fixed Height* a mixing process with a defined aspirating height and dispensing height can be determined.



*Fixed Height* should only be used for filling levels below the filling volume. At larger filling volumes, depending on the immersion depth selected, liquid may be forced out of the tube or well.

Enter the distance from the bottom of the tube in mm as the height.

*Asp.* stands for the distance of the pipette tip to the bottom of the tube when aspirating, *Disp.* stands for the distance of the pipette tip to the bottom of the tube when dispensing.

If you enter 0 mm in the *Asp.* field a correction of approx. ca. 2 mm upwards occurs after the execution. The correction depends on tube type and the tolerances of the tube type.

If you choose for *Disp.* a height which lies above the tube the dispensing is reduced automatically to the height of the tube.

If you select a height for *Disp.*, which is below that of *Asp.*, *Disp.* is raised to a height of *Asp.* on execution.

### 12.1.8 Exchange

This command is used to switch labware to the location in the current method.



The request to replenish identical tip racks (identical volume, with/without filter) is made automatically by the program, so no more tip racks of the same type need to be positioned in the parking positions.

---

Labware that is placed on the worktable from the parking positions within a method is not scanned by the optical sensor.

### Define parameters

There are 2 selection lists to enable you to view the labware on the worktable and in the parking positions. Selection enables Exchange for subsequent commands. When the method is started, at the request Exchange the location in question is displayed in addition to the name of the labware.



An alternative to *Exchange* is splitting into various part-methods. This would also allow liquid detection by the optical sensor for the labware to be used subsequently.

### 12.1.9 Wait

Use the Wait command to insert a pause in the method, e.g., to take account of temperature-control periods between two additions of reagent.

The duration of the pause is specified in the parameter settings.

### 12.1.10 Comment

Use the Comment command to display a comment at a certain point during execution of the method.

The comment command entered is shown marked as a command line during the method run, no separate window is displayed.

### 12.1.11 User Intervention

Use this command to interrupt a method, for example to perform manual steps.

If there is to be an alarm immediately before the manual intervention, mark the *Alarm* field.

Enter a corresponding comment on the intervention in the *Comment* field.

For methods with external steps which lead to a change in volume, divide these into 2 methods.

The following things must not happen at all with *User Intervention*:

- Change in position of carrier.
- Exchange of dispensing tools in locations T1 – T4.
- Positioning of labware which is not known to the method.
- Labware which is removed and then replaced may not be changed externally in terms of volume.
- Distance from labware required in the method. The waste container can be emptied in conjunction with this command. Then position the waste container correctly again.

## 12.2 Importing commands from a CSV file

When working with biological material (e.g., protein solutions, nucleic acid solutions), it may be necessary to transfer defined quantities of different samples from various parent solutions to a target container in order to adjust the concentration (thus creating standards). The quantities of sample material that must be transferred can be determined by physical measurements (e.g., by using spectroscopic methods, enzymatic analysis, or chemical methods), and the resulting quantities can then be listed in a table.

Using the menu function *Edit - Import from CSV* you can import a table in CSV format defining the volumes of sample material to be transferred from locations of a source tube to selected locations of a destination tube.

The imported table is converted into a sequence of Sample Transfer commands. With every imported Sample Transfer command the liquid of a specific source location is transferred to a specific destination location. The automatic pattern detection is not active for this command.

You can create and edit tables in CSV format using an editor or a spreadsheet. By importing a procedure from a file you can reuse the same sequence of commands in different methods by simply importing the sequence again from the same source file.



Barcode

At the top of the CSV file allocate names and barcode ID lists to the labware if required. From line 7 you can allocate the IDs to the individual steps and save them.

### 12.2.1 Creating a CSV file for import

A CSV file is an ASCII text file defining the structure and content of a table. Each line of text in the CSV file describes a row in the table. The content of the cells in each table row are separated by commas, semicolons or tab keys. You can create and edit a CSV with any simple ASCII text editor (e.g., Windows Notepad) or a spreadsheet (e.g., Microsoft Excel). The format of the CSV file has changed compared to epBlue Version 10.x.



If you use Microsoft Excel to create or edit a CSV file for import, make sure that the default separator for lists is not identical to the decimal point. I.e. in the Regional Settings for "English" in the Windows Control Panel the default separator for lists is a comma, so you cannot use the comma as a decimal point. Save your edited table in CSV format before exiting Excel (you do not need to save it also as an Excel file).

To create a CSV file make sure that the following prerequisites are met.

1. If you create your table in a spreadsheet and then export it to the CSV format make sure that the original spreadsheet file only contains one sheet, because only one sheet with table data can be exported to a CSV file.
2. Every Transfer command must be defined in a separate line. The values must always be sorted as follows: The first line contains *Rack*, *Source Barcode*, *Source List Name*, *Destination Barcode* and *Destination Name*. The names can also be abbreviated and also apply to plates. Rack 1-4 must be specified. In row 7 you enter *Barcode-ID*, *Rack* (Source rack), *Source* (Source location), *Rack* (Destination rack), *Destination* (Destination location), *Volume* (Transfer volume in  $\mu\text{L}$ ), *Tool* (dispensing tool) and *Name* (Sample name). The values in every line must be separated by commas, semicolons or tab keys. For decimal figures the decimal point or comma can be used. Make sure that the separator for lists is not identical to the decimal point. If you do not use barcodes the respective columns can be left without a value.



Even if you do not use barcodes the 1st and 7th row must be completed as described above. Each row must contain exactly 7 separators even if optional columns (e.g., barcode ID, name) are to remain empty.

To illustrate the required file structure the first table rows of a CSV file are shown in the example below the way they appear in the spreadsheet:

	A	B	C	D	E	F	G	H
1	Rack	Src.Barcode	Src.List Name	Dest.Barcode	Dest.List Name			
2		1	4711 Hamburg	4712	Köln			
3		2	815 Bremen					
4		3	911 Dresden					
5		4						
6								
7	Barcode ID	Rack	Source	Rack	Destination	Volume	Tool	Name
8			1 A1		1 A1		1	1 Sample 1
9			1 A2		1 A2		1	1 Sample 2
10			1 A3		1 A3		1	1 Sample 3
11			1 A4		1 A4		2	1 Sample 4
12			2 A1		1 A5		2	1 Sample 5
13			2 A2		1 A6		2	1 Sample 6
14			3 A1		1 A7		2	1 Sample 7

In comparison the same CSV file is shown here as it appears in an ASCII text editor:

```
Rack;Src.Barcode;Src.List Name;Dest.Barcode;Dest.List Name;;;
1;4711;Hamburg;4712;K"ln;;;
2;815;Bremen;;;;;
3;911;Dresden;;;;;
4;;;;;;

Barcode ID;Rack;Source;Rack;Destination;Volume;Tool;Name
;1;A1;1;A1;1;1;Sample 1
;1;A2;1;A2;1;1;Sample 2
;1;A3;1;A3;1;1;Sample 3
;1;A4;1;A4;2;1;Sample 4
;2;A1;1;A5;2;1;Sample 5
;2;A2;1;A6;2;1;Sample 6
;3;A1;1;A7;2;1;Sample 7
```

3. The values in the 6 rows of the CSV file must start in the second line of the file and then continue uninterrupted. No further entries must be made under these values because these would be interpreted as a command during import and cause errors.
4. If a line starts with "#", it is interpreted as comment and not imported.
5. A maximum of 500 Transfer commands can be imported from a CSV file into a method.
6. The number of racks specified in the CSV file as source and definition locations must match the number of racks defined in the first Sample Transfer command added manually to the method prior to importing the file . A maximum of 4 source locations and 4 destination locations can be used on the worktable. The exact source and destination locations on each plate can be entered as figures (1, 2, 3, etc.) or as alphanumeric coordinates on the plate (A1, B5, A3, etc.)
7. The tool numbers in the CSV file must match the dispensing tools as follows:
  - 1 - TS\_50
  - 2 - TS\_300
  - 3 - TS\_1000

TM dispensing tools cannot be used. It is recommended to avoid frequent dispensing tool changes within a method.

### 12.2.2 Importing a CSV file

Proceed as follows to import a sequence of Sample Transfer commands from a CSV file.



Make sure that the CSV file meets the requirements for import .

1. As a first step always add a Number of Samples command in a new procedure (see *Adding a command to the program on p. 65*).
2. In the parameter area of the Number of Samples command, enable the "Fix number of samples" option and set the number of samples to 1.

The number of samples is now limited for the following steps, so that every Sample Transfer command that follows is only executed once (i.e. for one sample).

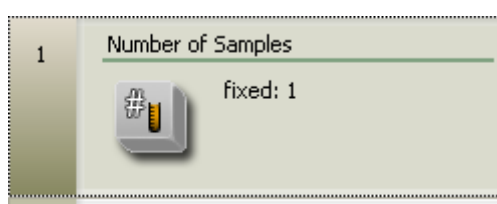

3. As a second step add a Sample Transfer command in the procedure (see *Adding a command to the program on p. 65*).

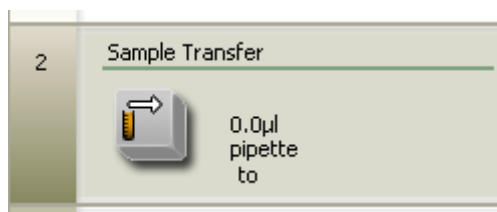

The first Sample Transfer command and its source and destination locations on the worktable serve as master configuration for the complete sequence of the commands imported from the CSV file. Only the source and destination locations defined manually in this first Sample Transfer command will be available during the sequence of the imported command.

4. Define the source and destination locations for the Sample Transfer command (see *Define the source vessel (Source) and destination vessel (Destination) for a transfer on p. 68*).

The following example shows a Sample Transfer command with 2 source locations and 2 destination locations. These locations are available for the imported command sequence.

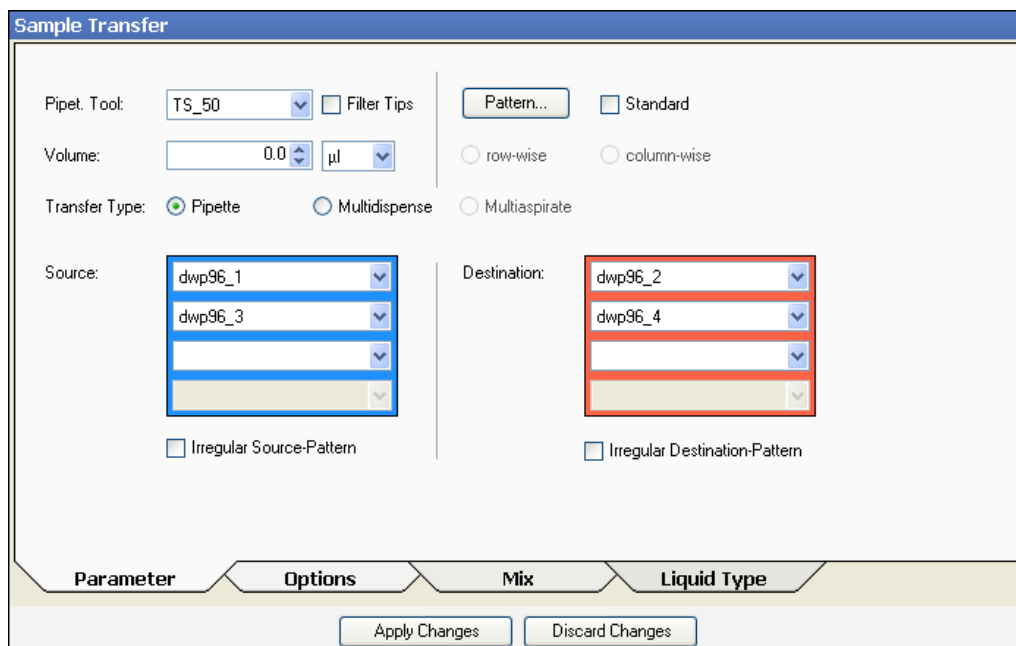

The number of racks specified in the CSV file as source and destination locations must match the number of racks defined with the first Sample Transfer command. A maximum of 4 source locations and 4 destination locations can be defined. The rack locations are then used in the order in which they appear in the parameter area of the first Sample Transfer command. I.e. if source rack 2 is specified in the file, the second rack in the list of source locations is used as source rack for the step.

- In the *Options* and *Mix* tabs in the parameter area of the Sample Transfer command define the options and mixing configurations you want to use for the sequence of the imported commands.

The options and mixing configurations manually defined for the first Sample Transfer command are copied and used for all imported commands. The "Elution from filter" option is not available for imported commands.

- Check the parameter settings for the first Sample Transfer command and ensure that they meet the requirements for the complete sequence of commands.

Please pay particular attention to the mixing volume and the mixing speeds, because these settings must be suitable for all imported commands. The preset value for the mixing speed must be overwritten manually with a different value. If you want to use different dispensing tools (including TS\_300), a mixing speed of 11 mm/sec is recommended.

- To import the command sequence from the file click on the Sample Transfer command in the program list to make sure it has been selected.

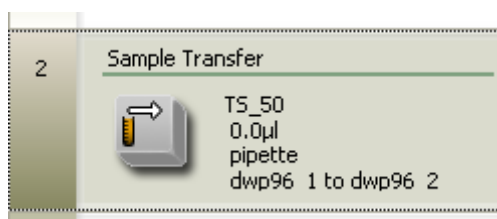

- In the main menu select *Edit - Import from CSV*.
- Select the CSV file you want to import and click on *Open*.

The CSV file is imported. Every line defined in the CSV file is added to the procedure as a Sample Transfer command with the settings defined in the file for source, destination, volume and tool. The imported command sequence is displayed in the program list.

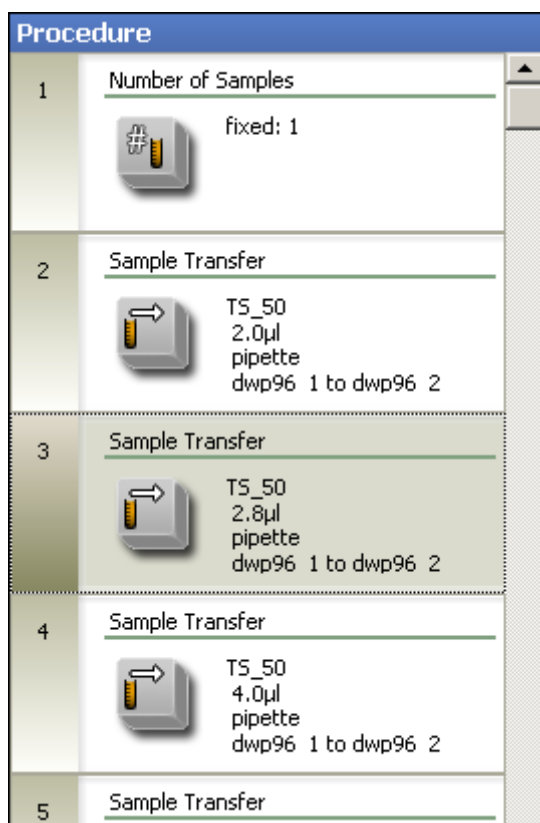

A maximum of 500 Transfer commands can be imported from a CSV file into a method.

## 12.3 Importing and exporting labware combinations

### 12.3.1 Importing labware combinations

1. In the start menu under *File* select the item *Import Labware*.  
The following window opens:

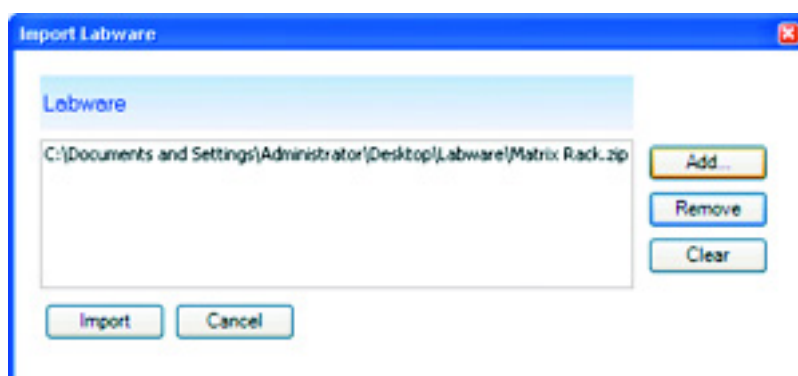

2. Add the labware to be imported to the list via *Add* and the following folder selection. Use *Remove* to delete individual files. Click on *Clear* to delete all files simultaneously.
3. Click on *Import*.

The following window opens:

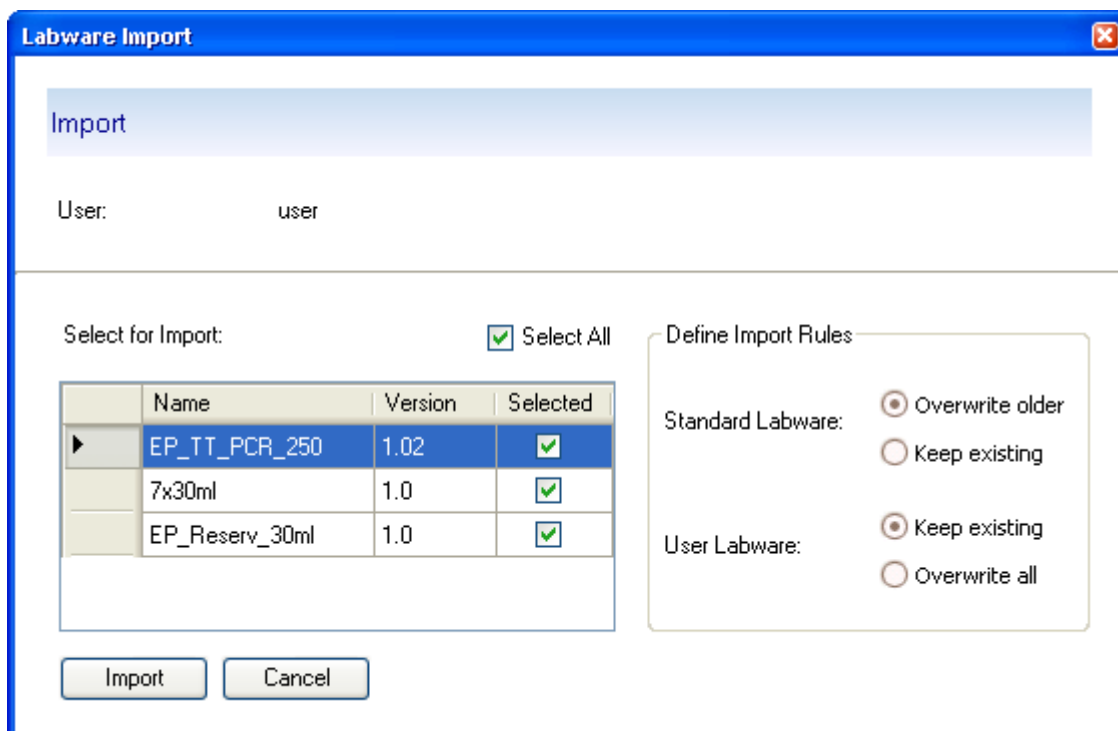

4. The labware (e.g., holder with the complete, added labware) is displayed in a list. Deselect any labware not required or already present, if necessary.
5. Define the import rules. The following are available:
  - *Keep existing*: Keeps the existing file with the same name.
  - *Overwrite older*: Older files are overwritten.
6. Click on *Import*.  
The labware files are imported to eBlue. An import summary appears in a window.
7. Click on *Finish* to complete the process.

### 12.3.2 Export labware combinations

1. In the start menu under *File*, select the *Export Labware* item.  
The following window opens:

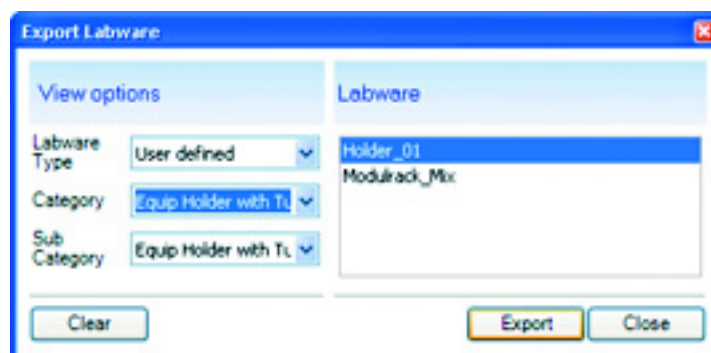

2. Select the *Labware Type* and the category of the labware to be exported.
3. Select the file to be exported from the list on the right.
4. Click on *Export* or click on *Clear* to reset the window to its original state.

5. Select a target folder and click on *OK*.
6. The labware (e.g., holder with the complete, added labware) is displayed in a list. Deselect any labware not required or already present, if necessary.
7. Click on *Export*.  
The labware files are exported to the destination folder. The import summary appears in a window.
8. Click on *Finish* to complete the process.

## 12.4 Defined applications

The User *ep* contains four subfolders with several applications for you to copy to your user directory where you can edit or start them.

Applications contained in *ep* cannot be started or edited there directly.

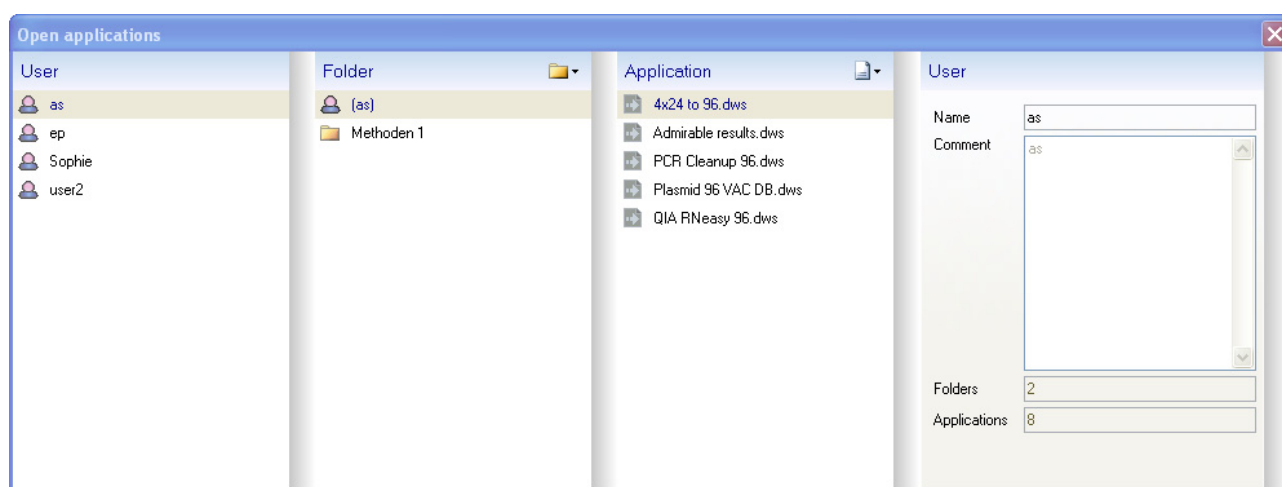

The defined applications are examples of the following areas:

- Nucleic acid preparation
- PCR setup
- Setup of sequencing reactions
- Routine liquid handling

Complete applications for nucleic acid preparation with kits from various manufacturers can be found on the webpage [www.epmotion.com](http://www.epmotion.com) under "Plug'n'prep" in the VIP area.



To better understand the descriptions you should display the contents of an application. Select the application and the information is displayed on the right-hand side of the screen.

## 13 Appendix C: BIOS password

### 13.1 Changing the BIOS password

To prevent unauthorized access to the BIOS setup a password can be set up:

1. Switch on the PC.
2. As soon as the BIOS starts press "F2" to open the setup.
3. Use the cursor to go to "security".
4. Use the cursor to go to "set supervisor password" and press Enter.  
The password field opens.
5. Enter and confirm a password.
6. Press F10 to save and exit the BIOS setup.

**Index**

**A**

Accessories	
Item number .....	161
Activate labware .....	93
Adapter	
Labware folder/.....	183
Thermoadapter Frosty .....	180
Add a command to a method .....	65
Admin tab .....	105
Administrator login .....	105
Application files .....	41
Application properties .....	47
Application Support .....	184
Applications	
Defined .....	223
Aspirate from bottom .....	198
Aspiration volume .....	22
Autoclaving	
Thermoadapter, thermoblock, thermorack .....	157
Automated pipetting system	
Item number .....	161

**B**

Barcode ID lists .....	40
Export .....	40
Import .....	40
Remove .....	41
Barcode reader	
Cleaning .....	156
before aspiration for next destination, well .....	200
before each aspiration .....	200
Bottom tolerance .....	93

**C**

Carrier	
Technical data .....	160
Change history .....	9
Change liquid type .....	202
Change tips .....	199
Changing the user password .....	112
Check commands .....	73
Check the method .....	73
Cleaning	
Barcode reader .....	156
Dispensing Tools .....	156
Thermoadapter, thermoblock, thermorack .....	156
Work surface adapter .....	156
Worktable .....	156
Client connection .....	106

Command check .....	73
Command icons .....	64
Command overview .....	64
Command parameters .....	67, 74
Command reference list .....	74
Commands	
Comment .....	216
Dilute .....	207
Exchange .....	215
Mix .....	213
Number of Samples .....	192
Pool .....	210
Pool One destination .....	211
Reagent Transfer .....	206
Sample Transfer .....	194
User Intervention .....	216
Wait .....	215
Comment .....	216
Comment command .....	79
Connect client .....	106
Control method run .....	87
Control tab .....	87
Copying applications .....	46
Create user account .....	109
Creating a user account .....	111

**D**

Deactivate labware .....	93
Debug log .....	86
Debug log for method run .....	86
Decontamination .....	157
Define module rack .....	95
Defining the procedure .....	63
Delete application .....	48
Deleting user accounts .....	112
Destination .....	68
Detection versions .....	188
Device list .....	107
Dilute .....	207
Dilute command .....	76
Dispense from top .....	199
Dispensing error .....	128
Dispensing sequence .....	33
Dispensing tool	
Installing .....	32
Removal .....	33
Sealing ring replacement .....	155
Dispensing tools .....	14
Item number .....	161
Disposal .....	167
Dosing device .....	104



**N**

Network..... 106  
 New application ..... 44  
 New folder..... 43  
 New user account ..... 109  
 Noise level ..... 160, 160  
 Number of Samples ..... 192  
 Number of Samples command ..... 75

**O**

Open an application..... 42  
 Operating controls  
     Dispensing tools..... 14  
     Optical sensor ..... 16  
     Overview ..... 13  
 Optical sensor ..... 102  
     Detection limits..... 191  
     Detection versions..... 188  
     Function ..... 186  
     Read error ..... 127  
     Tasks ..... 16  
     Technical data ..... 160  
     Tip detection..... 190  
 Overview of commands ..... 64

**P**

Parameter ..... 67, 74  
     Filter Tips ..... 194  
     Fix Number of Samples..... 192  
     Max Number of Samples..... 193  
     multidispense ..... 194  
     Pipet.Tool ..... 194  
     pipette ..... 194  
     Transfer Type..... 194  
     Volume ..... 194  
 Parameter test ..... 73  
 Parameters for Transfer command ..... 74  
 Password ..... 112  
 Password forgotten ..... 113  
 Pattern ..... 70  
 PCR accessories  
     Item number ..... 164  
 Pipet.Tool ..... 194  
 pipette tips..... 169  
     Change..... 199  
     Item number ..... 161  
 Plates ..... 180  
     Labware files ..... 180  
     Labware folder/..... 183  
 Pool..... 210  
 Pool command ..... 77  
 Pool One destination..... 211  
 Pool One Destination command ..... 77

Positioning labware..... 59  
 Print headers ..... 108  
 Printing applications ..... 56  
 Procedure tab ..... 63

**Q**

Quick start ..... 115

**R**

Rack 96 ..... 171  
 Rack LC ..... 171  
 Racks..... 170  
     Item number..... 163  
 Random Access ..... 189  
 Reagent reservoirs  
     Item number..... 162  
 Reagent Transfer ..... 206  
 Reagent Transfer command ..... 76  
 Reagent tubes ..... 170  
 Recent applications ..... 39  
 Reference list of commands ..... 74  
 Remaining volume ..... 20  
     Special cases..... 21  
 Remove command..... 67  
 Remove labware ..... 62  
 Reservoir rack ..... 98  
 ReservoirRack ..... 175  
 ReservoirRack module  
     Item number..... 163  
 ReservoirRack modules ..... 176  
 Reservoirs ..... 175  
     Item number..... 162  
 Reset a user password..... 113  
 Reset password..... 113  
 Reverse stroke..... 21  
 Run tab ..... 80  
 Run the method ..... 80, 87

**S**

Safety devices ..... 28  
 Sample Transfer ..... 194  
 Sample Transfer command..... 76  
 Saving applications..... 55  
 Short instructions..... 115  
 Source and destination..... 68  
 Stacking labware ..... 61, 61  
 Starting the method ..... 80  
 Stop method ..... 87  
 Support..... 184

## T

Technical data	
Barcode reader .....	160
Carrier .....	160
Dispensing Tools .....	159
Noise level .....	160
Optical sensor .....	160
Thermoadapter .....	174
Autoclaving .....	157
Cleaning .....	156
Thermoadapter Frosty .....	180
Thermoadapter LC Sample .....	174
Thermoblock	
Autoclaving .....	157
Cleaning .....	156
Cooling effect .....	174
Thermoblocks .....	172, 173
Thermoblocks with plates .....	183
Thermorack	
Autoclaving .....	157
Cleaning .....	156
Cooling effect .....	174
Thermorack and 0.2 mL tubes .....	173
Thermoracks .....	172, 173
Tip detection .....	190
Tips	
Labware folder/ .....	183
Tool interlock .....	103
Tools .....	184
Transfer command .....	68, 74
Transfer Command Pattern .....	70
Tubes + (Thermo)racks + Modules	
Labware folder/ .....	183
Tubs	
Labware folder/ .....	183
Two Location Rack .....	171

## U

Update Firmware .....	104
User account overview .....	108, 108
User accounts .....	109
User groups .....	114
User Intervention .....	216
User Intervention command .....	79
User password .....	112, 113

## V

Volume .....	22
Aspiration volume .....	22
Correction .....	24
Extra aspiration .....	22
Filling volume .....	19

Remaining volume .....	20
Required volume .....	22
Reverse stroke .....	21
terms .....	19
Working volume .....	20
Volume check .....	23

## W

Wait .....	215
Wait command .....	79
when command is finished .....	200
Work surface adapter	
Cleaning .....	156
Work tab .....	53
Working volume .....	20
Worktable	
Cleaning .....	156
Position labware .....	33
Worktable tab .....	58

# EG-Konformitätserklärung EC Conformity Declaration

Das bezeichnete Produkt entspricht den einschlägigen grundlegenden Anforderungen der aufgeführten EG-Richtlinien und Normen. Bei einer nicht mit uns abgestimmten Änderung des Produktes oder einer nicht bestimmungsgemäßen Anwendung verliert diese Erklärung ihre Gültigkeit.

The product named below fulfills the relevant fundamental requirements of the EC directives and standards listed. In the case of unauthorized modifications to the product or an unintended use this declaration becomes invalid.

Produktbezeichnung, Product name:

epMotion® 5070 mit integriertem PC / epMotion® 5070 with integrated PC

einschließlich Zubehör / including accessories

Produkttyp, Product type:

Automatisches Pipettiersystem / automated pipetting system

Einschlägige EG-Richtlinien/Normen, Relevant EC directives/standards:

2006/95/EG, EN 61010-1, EN 61010-2-81

2004/108/EG, EN 55011/B, EN 61000-6-1, EN 61000-3-2/3, EN 61326-2-6

EN ISO 8655-1/-2/-6



Vorstand, Board of Management:

25.02.2011

Hamburg, Date:



Projektmanagement, Project Management:

**eppendorf**



Eppendorf AG · Barkhausenweg 1 · 22339 Hamburg · Germany







Evaluate your operating manual

[www.eppendorf.com/manualfeedback](http://www.eppendorf.com/manualfeedback)

# eppendorf

**Your local distributor: [www.eppendorf.com/worldwide](http://www.eppendorf.com/worldwide)**

Eppendorf AG · 22331 Hamburg · Germany · Tel: +49 40 53801-0 · Fax: +49 40 538 01-556 · E-mail: [eppendorf@eppendorf.com](mailto:eppendorf@eppendorf.com)

Eppendorf North America, Inc. · 102 Motor Parkway · Hauppauge, N.Y. 11788-5178 · USA

Tel: +1 516 334 7500 · Toll free phone: +1 800-645-3050 · Fax: +1 516 334 7506 · E-mail: [info@eppendorf.com](mailto:info@eppendorf.com)

**Application Support** Europe: Tel: +49 1803 666 789 (Preis je nach Tarif im Ausland; 9 ct/min aus dem dt. Festnetz; Mobilfunkhöchstpreis 42 ct/min)  
[support@eppendorf.com](mailto:support@eppendorf.com)

North America: Tel: +1 800 645 3050 · E-mail: [techserv@eppendorf.com](mailto:techserv@eppendorf.com)

Asia Pacific: Tel: +60 3 8023 6869 · E-mail: [support\\_asiapacific@eppendorf.com](mailto:support_asiapacific@eppendorf.com)