



# Integrated Motion on the EtherNet/IP Network: Configuration and Startup

ControlLogix, CompactLogix, GuardLogix,  
Compact GuardLogix, iTRAK 5730, Kinetix 350, Kinetix 5300,  
Kinetix 5500, Kinetix 5700, Kinetix 6500, ArmorKinetix,  
PowerFlex 527, PowerFlex 755, PowerFlex Drive Products with  
TotalFORCE Control



**Allen-Bradley**

by ROCKWELL AUTOMATION

User Manual

Original Instructions

## Important User Information

Read this document and the documents listed in the additional resources section about installation, configuration, and operation of this equipment before you install, configure, operate, or maintain this product. Users are required to familiarize themselves with installation and wiring instructions in addition to requirements of all applicable codes, laws, and standards.

Activities including installation, adjustments, putting into service, use, assembly, disassembly, and maintenance are required to be carried out by suitably trained personnel in accordance with applicable code of practice.

If this equipment is used in a manner not specified by the manufacturer, the protection provided by the equipment may be impaired.

In no event will Rockwell Automation, Inc. be responsible or liable for indirect or consequential damages resulting from the use or application of this equipment.

The examples and diagrams in this manual are included solely for illustrative purposes. Because of the many variables and requirements associated with any particular installation, Rockwell Automation, Inc. cannot assume responsibility or liability for actual use based on the examples and diagrams.

No patent liability is assumed by Rockwell Automation, Inc. with respect to use of information, circuits, equipment, or software described in this manual.

Reproduction of the contents of this manual, in whole or in part, without written permission of Rockwell Automation, Inc., is prohibited.

Throughout this manual, when necessary, we use notes to make you aware of safety considerations.



**WARNING:** Identifies information about practices or circumstances that can cause an explosion in a hazardous environment, which may lead to personal injury or death, property damage, or economic loss.

---



**ATTENTION:** Identifies information about practices or circumstances that can lead to personal injury or death, property damage, or economic loss. Attentions help you identify a hazard, avoid a hazard, and recognize the consequence.

---

**IMPORTANT** Identifies information that is critical for successful application and understanding of the product.

---

These labels may also be on or inside the equipment to provide specific precautions.



**SHOCK HAZARD:** Labels may be on or inside the equipment, for example, a drive or motor, to alert people that dangerous voltage may be present.

---



**BURN HAZARD:** Labels may be on or inside the equipment, for example, a drive or motor, to alert people that surfaces may reach dangerous temperatures.

---



**ARC FLASH HAZARD:** Labels may be on or inside the equipment, for example, a motor control center, to alert people to potential Arc Flash. Arc Flash will cause severe injury or death. Wear proper Personal Protective Equipment (PPE). Follow ALL Regulatory requirements for safe work practices and for Personal Protective Equipment (PPE).

---

The following icon may appear in the text of this document.



Identifies information that is useful and can help to make a process easier to do or easier to understand.

Rockwell Automation recognizes that some of the terms that are currently used in our industry and in this publication are not in alignment with the movement toward inclusive language in technology. We are proactively collaborating with industry peers to find alternatives to such terms and making changes to our products and content. Please excuse the use of such terms in our content while we implement these changes.

	<b>Preface</b>	
	About This Publication .....	9
	Download Firmware, AOP, EDS, and Other Files .....	9
	Inclusive Terminology .....	9
	Summary of Changes .....	9
	Additional Resources .....	9
	<b>Chapter 1</b>	
<b>Components of a Motion System</b>	Controller, Communication, Drive, and Software Options .....	11
	Help for Selecting Drives and Motors .....	13
	<b>Chapter 2</b>	
<b>Configure Drive Properties</b>	Before You Begin .....	15
	Add a Kinetix Drive .....	17
	Add a PowerFlex Drive .....	18
	Add a Peripheral Device for PowerFlex 755 Drives .....	19
	Add an iTRAK Section, Mover, or Power Supply .....	20
	Configure Module Definition .....	22
	Safety Application Types .....	24
	Connection Types .....	25
	Safety Instance .....	25
	Motion Safety Type .....	26
	Axis Test Mode .....	26
	Configure Power Settings .....	26
	Configure Predictive Maintenance .....	29
	Configure Digital Inputs .....	30
	Configure Digital Outputs .....	30
	Configure Safety Settings .....	31
	Configure Safety Connections .....	32
	Generate the Safety Network Number (Integrated safety drives only) .....	33
	Configure Track Sections .....	34
	<b>Chapter 3</b>	
<b>Configure Axis Properties</b>	Create an Associated Axis .....	37
	Create an Axis .....	37
	Specify Feedback Assignments .....	38
	Create a Motion Group .....	39
	Set the Base Update Period .....	40
	Associate Axes to the Motion Group .....	42
	Configure an Axis and Feedback Type .....	42
	Complete Axis Configuration .....	46
	Configure Application Type, Loop Response, and Test Mode .....	46
	Axis Test Mode .....	47
	Complete Axis Configuration for Converter Types .....	47
	Specify the Motor Data Source .....	48

	Choose the Catalog Number as the Motor Data Source . . . . .	48
	Display Motor Model Information . . . . .	51
	Use Motor Analyzer . . . . .	51
	Assign Motor Feedback . . . . .	53
	Configure Commutation . . . . .	54
	Configure Load Feedback . . . . .	55
	Configure Master Feedback . . . . .	55
	Configure Feedback Only Axis Properties . . . . .	56
	Configure Actions . . . . .	56
	Configure Exceptions . . . . .	57
	 <b>Chapter 4</b>	
<b>Axis Scheduling</b>	Timing Model . . . . .	60
	One Cycle Timing . . . . .	61
	Axis Scheduling Configuration . . . . .	63
	Configure the Update Periods . . . . .	63
	Motion Utilization . . . . .	69
	 <b>Chapter 5</b>	
<b>Configuration Examples for a Kinetix Drive</b>	Example 1: Position Loop with Motor Feedback Only . . . . .	71
	Example 2: Position Loop with Dual Feedback . . . . .	74
	Example 3: Feedback Only . . . . .	78
	Example 4: Kinetix 5500 Drive, Velocity Loop with Motor Feedback . . . . .	81
	Example 5: Kinetix 5700 Drive, Frequency Control with No Feedback . . . . .	85
	Example 6: 842E-CM Integrated Motion Encoder with Master Feedback . . . . .	87
	 <b>Chapter 6</b>	
<b>Axis Configuration Examples for the PowerFlex 755 Drive</b>	Example 1: Position Loop with Motor Feedback Via a UFB Feedback Device . . . . .	91
	Example 2: Position Loop with Dual Motor Feedback Via a UFB Feedback Device . . . . .	93
	Example 3: Velocity Loop with Motor Feedback Via a UFB Feedback Device . . . . .	97
	Example 4: Velocity Loop with No Feedback . . . . .	101
	Example 5: Frequency Control with No Feedback . . . . .	103
	Example 6: Torque Loop with Feedback . . . . .	106
	 <b>Chapter 7</b>	
<b>Axis Configuration Examples for the PowerFlex 527 Drive</b>	Example 1: Frequency Control with No Feedback . . . . .	109
	Example 2: Velocity Control with Motor Feedback . . . . .	112
	Example 3: Position Control with Motor Feedback . . . . .	114
	 <b>Chapter 8</b>	
<b>Commission an Axis</b>	Scaling . . . . .	119
	Direct Coupled Rotary . . . . .	120
	Direct Coupled Linear . . . . .	120
	Rotary Transmission . . . . .	121
	Linear Actuator . . . . .	121
	Changing Scaling Factors . . . . .	121
	Hookup Tests . . . . .	122

Run a Motor and Feedback Test .....	126
Run a Motor Feedback Test .....	127
Run a Marker Test .....	128
Applying the Commutation Hookup Test .....	128
Unknown Commutation Offset .....	129
Verification of Known Commutation Offset .....	129
Non-standard or Incorrect Wiring .....	129
Run a Commutation Test .....	129
Polarity .....	130
Autotune .....	131
Load .....	133
Load Observer .....	135
Benefits of Load Observer .....	135
How Load Observer Functions .....	135
Load Observer Configuration .....	136
Adaptive Tuning .....	137
Benefits of Adaptive Tuning .....	137
How Adaptive Tuning Functions .....	137
Adaptive Tuning Configuration .....	138
Command Notch Filters .....	140
Load Ratio Data from Motion Analyzer .....	141
Test an Axis with Motion Direct Commands .....	141
Access Motion Direct Commands for an Axis or Group .....	142
Understanding STO Bypass When Using Motion Direct Commands .....	144

## Chapter 9

### Axis Test Mode

What is Axis Test Mode? .....	147
Axis Test Mode Scope .....	147
Use Cases for Axis Test Mode .....	148
Enable Axis Test Mode .....	148
From the Axis Properties .....	149
From the Motion Group .....	149
From the Tools Tab .....	150
Axis Simulation .....	150
Axis Test Mode Limitations .....	150
Safety Simulation Considerations .....	152
Safe-Torque Off (STO) Considerations .....	152
Safe Feedback Interface (SFX) Considerations .....	152
Safe Stop 1 (SS1) Considerations .....	153
Safe Brake Control (SBC) Considerations .....	153

## Chapter 10

### Homing

Guidelines for Homing .....	155
Active Homing .....	156
Passive Homing .....	156
Examples .....	156
Active Homing .....	156
Passive Homing .....	159
Absolute Position Recovery (APR) .....	159

	APR Terminology . . . . .	160
	Position Recovery Considerations for Logix 5000 Controllers . . . . .	160
	Absolute Feedback Device . . . . .	160
	SERCOS Versus Integrated Motion on Ethernet Networks . . . . .	161
	APR Scenarios . . . . .	161
	APR Faults . . . . .	164
	APR Fault Conditions . . . . .	164
	APR Fault Generation . . . . .	165
	APR Fault Examples . . . . .	167
	Resetting an APR Fault . . . . .	168
	Absolute Position Loss without APR Faults . . . . .	168
	Behavior of APR for Incremental Encoders . . . . .	168
	 <b>Chapter 11</b>	
<b>Manual Tune</b>	When to Manually Tune an Axis . . . . .	169
	Axis Configuration Types . . . . .	169
	Current Tuning Configuration . . . . .	169
	Loop Responses . . . . .	169
	Tune The Axis . . . . .	171
	Motion Generator and Motion Direct Commands . . . . .	172
	Additional Tune . . . . .	173
	Feedforward Parameters . . . . .	174
	Compensation Parameters . . . . .	174
	Torque Notch Filters Parameters . . . . .	175
	Torque Filters Parameters . . . . .	175
	Command Notch Filters Parameters . . . . .	175
	Adaptive Tuning Parameters . . . . .	176
	Limits Parameters . . . . .	176
	Planner Parameters . . . . .	177
	Configure Torque Values . . . . .	177
	Monitor Tags with the Quick Watch Window . . . . .	178
	Use Motion Generator . . . . .	179
	 <b>Chapter 12</b>	
<b>Status, Faults, and Alarms</b>	Faults and Alarms Dialog Box . . . . .	183
	QuickView Pane . . . . .	185
	Data Monitor . . . . .	185
	Motion Status . . . . .	185
	Drive Status Indicators . . . . .	186
	Connection Faults and Errors . . . . .	186
	Motion Faults . . . . .	187
	Manage Motion Faults . . . . .	187
	Configure the Exception Actions for AXIS_CIP_DRIVE . . . . .	188
	Inhibit an Axis . . . . .	191
	Example: Inhibit and Axis . . . . .	192
	Example: Uninhibit an Axis . . . . .	193

<b>Parameter Group Dialog Boxes</b>	<b>Appendix A</b>	
	Parameter Group Dialog Boxes .....	195
<b>Program a Velocity Profile and Jerk Rate</b>	<b>Appendix B</b>	
	Program a Velocity Profile and Jerk Rate .....	197
	Definition of Jerk .....	197
	Choose a Profile .....	197
	Use % of Time for the Easiest Programming of Jerk .....	198
	Velocity Profile Effects.....	199
	Jerk Rate Calculation .....	199
	Profile Operand .....	203
	Enter Basic Logic .....	205
	Example Motion Control Program .....	206
	Download a Project.....	207
	Choose a Motion Instruction .....	207
	Troubleshoot Axis Motion.....	209
	Why Does My Axis Accelerate When I Stop It? .....	210
	Why Does My Axis Overshoot Its Target Speed? .....	211
	Why Is There a Delay When I Stop and Then Restart a Jog? .....	213
	Why Does The Axis Reverse Direction When Stopped and Started? .....	214
	Programming with the MDSC Function.....	217
<b>PowerFlex Out-of-Box Configuration</b>	<b>Appendix C</b>	
	Recommended Out-of-Box Settings.....	221
	Setting the ACO/AVO Attribute for PowerFlex 527 Drives Only.....	225
	<b>Glossary .....</b>	<b>227</b>
	<b>Index .....</b>	<b>229</b>

**Notes:**

## About This Publication

Use this manual to configure an integrated motion on the EtherNet/IP™ network application and to start up your motion solution with a Logix controller-based system.

See [Integrated Motion on EtherNet/IP Networks for PowerFlex® Drives with TotalFORCE® Application Technique](#), publication [750-AT007](#) to configure and troubleshoot PowerFlex drive products with TotalFORCE Control in several different integrated motion axis modes by using the Studio 5000 Logix Designer® application.

This manual is designed to give you a straightforward approach to an integrated motion control solution. If you have any comments or suggestions, see [Documentation Feedback](#) on the back cover of this manual.

## Download Firmware, AOP, EDS, and Other Files

Download firmware, associated files (such as AOP, EDS, and DTM), and access product release notes from the Product Compatibility and Download Center at [rok.auto/pcdc](http://rok.auto/pcdc).

## Inclusive Terminology

Rockwell Automation recognizes that some of the terms that are currently used in our industry and in this publication are not in alignment with the movement toward inclusive language in technology.

We are proactively collaborating with industry peers to find alternatives to such terms and making changes to our products and content. Please excuse the use of such terms in our content while we implement these changes.

## Summary of Changes

This publication contains the following new or updated information. This list includes substantive updates only and is not intended to reflect all changes.

Topic	Page
Updated the APR Recovery Scenarios table.	162
Added Motion Run Motor Test (MRMT) to the Available Motion Direct Commands table.	209

## Additional Resources

These documents contain additional information concerning related products from Rockwell Automation. You can view or download publications at [rok.auto/literature](http://rok.auto/literature).

Resource	Description
Integrated Motion on the EtherNet/IP Network Reference Manual, publication <a href="#">MOTION-RM003</a>	Provides a programmer with details about the Integrated Motion on the EtherNet/IP network Control Modes, Control Methods, and AXIS_CIP_DRIVE Attributes.
Logix 5000® Controllers Motion Instructions Reference Manual, publication <a href="#">MOTION-RM002</a>	Provides a programmer with details about motion instructions for a Logix-based controller.
Motion System Tuning Application Technique, publication <a href="#">MOTION-AT005</a>	Provides detailed information on motion system tuning.
Tuningless Features Configuration Quick Start, publication <a href="#">MOTION-OS001</a>	Provides information to quickly tune Kinetix drives.
The Integrated Architecture® and CIP Sync™ Configuration Application Technique, publication <a href="#">IA-AT003</a>	Provides detailed configuration information on CIP Sync technology and time synchronization.
Motor Nameplate Datasheet Entry for Custom Motor Applications Application Technique, publication <a href="#">2198-AT002</a>	Provides information on the use of nameplate data entry for custom induction motors and permanent-magnet motors that are used in applications with Kinetix 5700 servo drives.
Kinetix Rotary Motion Specifications Technical Data, publication <a href="#">KNX-TD001</a>	Product specifications for Kinetix® VPL, VPC, VPF, VPH, and VPS; Kinetix MPL, MPM, MPF, and MPS; Kinetix TLY and TL; Kinetix HPK; and Kinetix MMA rotary motors.
Kinetix Linear Motion Specifications Technical Data, publication <a href="#">KNX-TD002</a>	Product specifications for Kinetix MPAS and MPMA linear stages, Kinetix MPAR and MPAL electric cylinders, and Kinetix LDC and LDL linear motors.
Kinetix 5700, 5500, 5300, 5100 Servo Drives Specifications, publication <a href="#">KNX-TD003</a>	Provides product specifications for Kinetix Integrated Motion over the EtherNet/IP network and EtherNet/IP networking servo drive families.
Kinetix Rotary and Linear Motion Cable Specifications Technical Data, publication <a href="#">KNX-TD004</a>	Product specifications for Kinetix 2090 motor and interface cables.
iTRAK 5730 System User Manual, publication <a href="#">2198T-UM003</a>	Provides information and instructions for how to assemble, lift, mount, connect, configure, troubleshoot, and maintain an iTRAK® 5730 system.
Kinetix 350 Single-axis EtherNet/IP Servo Drive User Manual, publication <a href="#">2097-UM002</a>	Provides detailed information on wiring, power, troubleshooting, and integration with ControlLogix®, or CompactLogix™ controller platforms.

Resource	Description
Kinetix 5300 Single-axis EtherNet/IP Servo Drives User Manual, publication <a href="#">2198-UM005</a>	Provides detailed installation instructions to mount, wire, and troubleshoot the Kinetix 5300 servo drives, and system integration for your drive and motor/actuator combination with a Logix 5000 controller.
Kinetix 5500 Servo Drives Installation Instructions, publication <a href="#">2198-IN001</a>	Provides installation instructions for the Kinetix 5500 Integrated Axis Module and Axis Module components.
Kinetix 5500 Servo Drives User Manual, publication <a href="#">2198-UM001</a>	Provides information on installation, configuration, startup, troubleshooting, and applications for the Kinetix 5500 servo drive systems.
Kinetix 5700 Safe Monitor Functions Reference Manual, publication <a href="#">2198-RM001</a>	Explains how the Kinetix 5700 drives can be used in up to Safety Integrity Level (SIL 3), Performance Level (PLe) applications.
Kinetix 5700 Servo Drives User Manual, publication <a href="#">2198-UM002</a>	Provides information on installing, configuring, startup, troubleshooting, and applications for the Kinetix 5700 servo drive systems.
ArmorKinetix System Safe Monitor Functions Reference Manual, publication <a href="#">2198-RM007</a>	Explains how the ArmorKinetix modules can be used in up to Safety Integrity Level (SIL 3), Performance Level (PLe) applications.
ArmorKinetix System User Manual, publication <a href="#">2198-UM006</a>	Provides information on installing, configuring, startup, troubleshooting, and applications for the ArmorKinetix power interface module (PIM), distributed servo drive (DSD), and distributed servo motor (DSM).
Kinetix 6200 and Kinetix 6500 Modular Multi-axis Servo Drives User Manual, publication <a href="#">2094-UM002</a>	Provides information on installation, configuration, startup, troubleshooting, and applications for the Kinetix 6200 and Kinetix 6500 servo drive systems.
PowerFlex 527 Adjustable Frequency AC Drive User Manual, publication <a href="#">520-UM002</a>	Provides information on installation, configuration, startup, troubleshooting, and applications for the PowerFlex 527 drive.
Integrated Motion on EtherNet/IP Networks for PowerFlex Drives with TotalFORCE Application Technique, publication <a href="#">750-AT007</a>	Describes how to configure and troubleshoot PowerFlex drive products with TotalFORCE Control in several different integrated motion axis modes by using the Studio 5000 Logix Designer® application.
PowerFlex 750-Series AC Drives Programming Manual, publication <a href="#">750-PM001</a>	Provides information that is necessary to install, startup, and troubleshoot PowerFlex 750-Series Adjustable Frequency AC Drives.
PowerFlex 750-Series AC Drives Reference Manual, publication <a href="#">750-RM002</a>	Provides detailed drive information including operation, parameter descriptions, and programming of the AC drive.
842E-CM Integrated Motion Encoder on EtherNet/IP User Manual, publication <a href="#">842E-UM002</a>	Describes the necessary tasks to install, wire, and troubleshoot your encoder.
PowerFlex 750-Series Products with TotalFORCE Control Technical Data, publication <a href="#">750-TD100</a>	Provides detailed information on: <ul style="list-style-type: none"> <li>• Drive and bus supply specifications</li> <li>• Option specifications</li> <li>• Fuse and circuit breaker ratings</li> </ul>
PowerFlex 750-Series Products with TotalFORCE Control Installation Instructions, publication <a href="#">750-IN100</a>	Provides the basic steps to install PowerFlex 755TL low harmonic drives, PowerFlex 755TR regenerative drives, and PowerFlex 755TM drive systems.
PowerFlex Drives with TotalFORCE Control Programming Manual, publication <a href="#">750-PM101</a>	Provides detailed information on startup, control algorithms, and status indicators.
Product Certifications website, <a href="http://rok.auto/certifications">rok.auto/certifications</a> .	Provides declarations of conformity, certificates, and other certification details.

## Components of a Motion System

### Controller, Communication, Drive, and Software Options

To create an Integrated Motion on EtherNet/IP™ system, you need the following:

- A Logix 5000® controller with a connection to the EtherNet/IP network, either via an embedded Ethernet port or an Ethernet communication module (See [Table 1](#))
- An Integrated Motion drive (see [Table 2](#))
- Software
  - Studio 5000 Logix Designer® application
  - RSLinx® Classic software, version 3.51.00 or later
  - For PowerFlex® 755 drives, you need the Add-on Profile, version 18 or later
  - For PowerFlex 755T drives, you need the Add-on Profile, version 36 or later

A safety controller is required for motion and safety applications.



When a PowerFlex 755 drive is used in Integrated Motion on EtherNet/IP mode, the Logix controller and Studio 5000 Logix Designer application are the exclusive owners of the drive. A HIM or other drive software tools, such as DriveExplorer™ and Connected Components Workbench software, cannot be used to control the drive or change configuration settings. These tools can only be used for monitoring.

See the [Product Compatibility and Download Center \(PCDC\)](#) for minimum controller, Ethernet module, and drive firmware revisions, Studio 5000 Logix Designer application required revisions, and compatibility information.

[Table 1](#) provides information on how many motion axes are supported depending on the hardware that is used in your application and the configuration of your axes. For example, you can have eight Position Loop axes per 1756-EN2T module. Each drive requires one TCP and one CIP™ connection. If you have other devices that consume TCP connections on the module, it reduces the number of drives you can support. Only the drives and axes that are configured for Position Loop are limited. Frequency Control, Velocity Loop, and Torque Loop configured drives and axes are not limited.

**Table 1 - Supported Axes by Controller Type**

Controller	Communication Modules <sup>(1)</sup>	Supported Axes <sup>(2)</sup>	
		Position Loop	Other Loop Types
ControlLogix® 5570, GuardLogix® 5570 Armor™ ControlLogix 5570, Armor GuardLogix 5570	1756-EN2T, 1756-EN2TF, 1756-EN2TP, 1756-EN2TR	8	Up to 100
	1756-EN3TR	100	
	1756-EN4TR	100	
ControlLogix 5580, GuardLogix 5580	1756-EN2T, 1756-EN2F, 1756-EN2TP, 1756-EN2TR	8	Up to 256
	1756-EN3TR	256	
	1756-EN4TR	256	
ControlLogix 5580, GuardLogix 5580	1756-L81E, 1756-L81ES	Embedded Ethernet <sup>(3)</sup>	Up to 256
	1756-L82E, 1756-L82ES		
	1756-L83E, 1756-L83ES, 1756-L84E, 1756-L84ES		
	1756-L85E		

Table 1 - Supported Axes by Controller Type (Continued)

Controller	Communication Modules <sup>(1)</sup>	Supported Axes <sup>(2)</sup>	
		Position Loop	Other Loop Types
CompactLogix™ 5380, Compact GuardLogix 5380	Embedded Ethernet	2	Up to 256
		4	
		8	
		16	
		20	
		24	
		28	
		32	
CompactLogix 5370, Compact GuardLogix 5370, Armor CompactLogix 5370, Armor Compact GuardLogix 5370	Embedded Ethernet	2	Up to 100
		4	
		4	
		8	
		16	
		16	
		16	
		16	
Compact GuardLogix SIL 3 Controllers	Embedded Ethernet	2	Up to 256
		4	
		8	
		16	
		20	
		24	
		28	
		32	

(1) For more information on Ethernet communication modules, see 1756 ControlLogix Communication Modules Specifications Technical Data, publication [1756-TD003](#).  
 (2) Multiple controllers can control drives on a common 1756-ENxTx module, so based on the TCP connection limit, up to 128 can be supported.  
 (3) ControlLogix 5580 and GuardLogix 5580 can also use Ethernet communication modules to communicate on the EtherNet/IP network.

[Table 2](#) describes the EtherNet/IP products available for integrated motion.

Table 2 - Integrated Motion EtherNet/IP Products

Drive	Description
842E-CM Absolute Encoders	The 842E-CM is an ultra-high resolution encoder with EtherNet/IP interface with time synchronization for motion control. These encoders provide 18-bit single-turn resolution and 30-bit multi-turn resolution.
Kinetix® 350	The Kinetix 350 drive is a single-axis EtherNet/IP servo drive with hardwired Safe Torque Off (STO) with connection to safety inputs.
Kinetix 5300	The Kinetix 5300 servo drive is an entry-level servo drive that is integrated on EtherNet/IP.
Kinetix 5500	The Kinetix 5500 servo drives support the Integrated Motion on EtherNet/IP network. Single-axis and multi-axis, AC, DC, AC/DC, and AC/DC hybrid bus-sharing configurations are possible.
	2198-Hxxx-ERS servo drives support hardwired Safe Torque Off (STO) with connections to safety inputs.
	2198-Hxxx-ERS2 servo drives support integrated Safe Torque Off (STO) with connections to the safety controller.
Kinetix 5700	2198-Sxxx-ERS3 (single-axis) and 2198-Dxxx-ERS3 (dual-axis) series A support that is hardwired and integrated STO with connections to the safety controller. Series B also support integrated Timed SS1 safety function.
	2198-Sxxx-ERS4 (single-axis) and 2198-Dxxx-ERS4 (dual-axis) inverters support integrated safe monitor functions with connection to the safety controller.
	2198-Pxxx DC Bus Supply provides power in a range of 7...46 kW and 10.5...69.2 A output current to Kinetix 2198 single-axis and dual-axis inverters for applications.
	2198-RPxxx Regenerative Bus Supply provides continuous output power and current to Kinetix 2198 single-axis and dual-axis inverters for applications.

Table 2 - Integrated Motion EtherNet/IP Products (Continued)

Drive	Description
ArmorKinetix® DSD and DSM Modules	2198-DSD0xx-ERS2 and 2198-DSD0xx-ERS5 single-axis inverters with current ratings up to 8 A rms. Drives feature TÜV Rheinland-certified Safe Torque Off function with integrated safety connection options, PLe and SIL 3 safety ratings, and support for Hiperface DSL, and Hiperface encoder feedback. The DSD modules also support Timed and Monitored SS1 drive-based stopping functions, and support controller-based Safe Stop 1 and safe speed monitoring functions over the Ethernet network.
	2198-DSM0xx-ERS2 and 2198-DSM0xx-ERS5 single-axis motor/inverter with maximum continuous torque of 11.9 N•m (105.3 lb•in) and peak torque of 31.2 N•m (276.1 lb•in) with speeds up to 8000 rpm. The -ERS2 motor/inverters feature TÜV Rheinland-certified Safe Torque Off function with integrate safety connection, PLe, and SIL 3 for Hiperface DSL feedback only. The modules also support Timed SS1 drive-based stopping functions. The 2198-DSMxxx-ERS5 modules also support Timed and Monitored SS1 drive-based stopping functions, and support controller-based Safe Stop 1 and Safely-limited Speed functions.
	2198-Pxxx DC Bus Supply provides power in a range of 7...46 kW and 10.5...69.2 A output current to 2198 modules for applications.
Kinetix 6500	The Kinetix 6500 drive is a closed-loop modular servo drive. It consists of an integrated axis (IAM) power module and up to seven axis (AM) power modules, each coupled with a Kinetix 6500 control module. The IAM and AM power modules provide power for up to eight axes. The 2094-EN02D-M01-S0 control modules support Safe Torque Off (STO) and 2094-EN02D-M01-S1 control modules support safe-speed monitoring.
PowerFlex 527	The PowerFlex 527 is a single-axis EtherNet/IP AC drive with hardwired and Integrated Safe Torque Off (STO). It consists of an integrated axis power module and incremental encoder feedback (sold separately).
PowerFlex 755	The PowerFlex 755 Drive EtherNet/IP AC drive can control a motor in closed loop and open loop mode. The PowerFlex 755 drive contains an EtherNet/IP adapter that is embedded on the main control board. Drive option modules provide I/O, safety <sup>(1)(2)</sup> , and feedback functions to the drive.
PowerFlex 755T Drive Products	PowerFlex 755T Drive Products provide harmonic mitigation, regeneration, non-regenerative, and common bus solutions that use TotalFORCE® technology to achieve excellent motor control through precise, adaptive control of torque, velocity, and position for electric motors.
iTRAK® 5730 Intelligent Track System	The iTRAK 5730 system is a modular, scalable, linear motor system. This system provides independent control of multiple movers on straight or curvilinear paths.
iTRAK Power Supply	Catalog number 2198T-W25K-ER, DC-DC converter that generates DC-bus power for iTRAK systems.

(1) Integrated Motion support of the Integrated Safety Functions option module (20-750-S4) is only available when used with GuardLogix 5580 and Compact GuardLogix 5380 safety controllers.

(2) PowerFlex Drive firmware revision 14 or later required for Integrated Safe Torque Off option module (20-750-S3) Integrated Safety Functions option module (20-750-S4)

## Help for Selecting Drives and Motors

FactoryTalk® Motion Analyzer Online helps you select the appropriate Allen-Bradley® drives and motors that are based on your load characteristics and typical motion application cycles. The software guides you through wizard-like screens to collect information specific to your application.

After you enter the information for your application, such as, load inertia, gearbox ratio, feedback device, and brake requirements, the software generates an easy-to-read list of recommended motors, drives, and other support equipment.

You can access Motion Analyzer at [rok.auto/motion-analyzer](http://rok.auto/motion-analyzer).

**Notes:**

## Configure Drive Properties

This chapter describes the basic steps for how to configure an integrated motion project in the Studio 5000 Logix Designer® application. For detailed product-specific configuration, see the user manual for your product.

---

**IMPORTANT** When a PowerFlex® drive is used in Integrated Motion on EtherNet/IP™ mode, the Logix controller and Studio 5000 Logix Designer application are the exclusive owners of the drive (the same as Kinetix® drives). A HIM (human interface module) or other drive software tools cannot be used to control the drive or change configuration settings. These tools can only be used for monitoring.

If you use a PowerFlex Safe Speed Monitor module (catalog number 20-750-S1) with a PowerFlex 755 drive, you can use a 20-HIM-A6 module or Connected Components Workbook, to configure the safety portion because Studio 5000 Logix Designer applications do not configure the drive.

---

### Before You Begin

Before you can configure a drive in the Logix Designer application, you must create a controller project with a connection to the EtherNet/IP network as shown in [Figure 1 on page 16](#).

Keep these considerations in mind when creating your motion project.

- For a Motion and Safety application, you must add a GuardLogix® integrated safety controller.
- For all communication modules, use the firmware revision that matches the firmware revision of your controller. See the release notes for the firmware revision of your controller.
- The electronic keying feature automatically compares the expected module, as shown in the configuration tree, to the physical module before communication begins.



**ATTENTION:** When configuring communication modules in motion or safety applications, set electronic keying to either Exact Match or Compatible Keying. Never use Disable Keying with motion or safety applications.

For more information about electronic keying, see the Electronic Keying in Logix 5000™ Control Systems Application Technique, publication [LOGIX-AT001](#).

- Time synchronization supports highly distributed applications that require time stamping, sequence of events recording, distributed motion control, and increased control coordination. All controllers and communication modules must have time synchronization enabled for applications that use Integrated Motion on the EtherNet/IP network.

See the Integrated Architecture® and CIP Sync™ Configuration Application Technique, publication [IA-AT003](#), for detailed information on time synchronization.

For detailed information on configuring a controller or Ethernet/IP adapter, see the publications that are listed in the [Additional Resources on page 9](#).

Figure 1 - Create a Motion Project

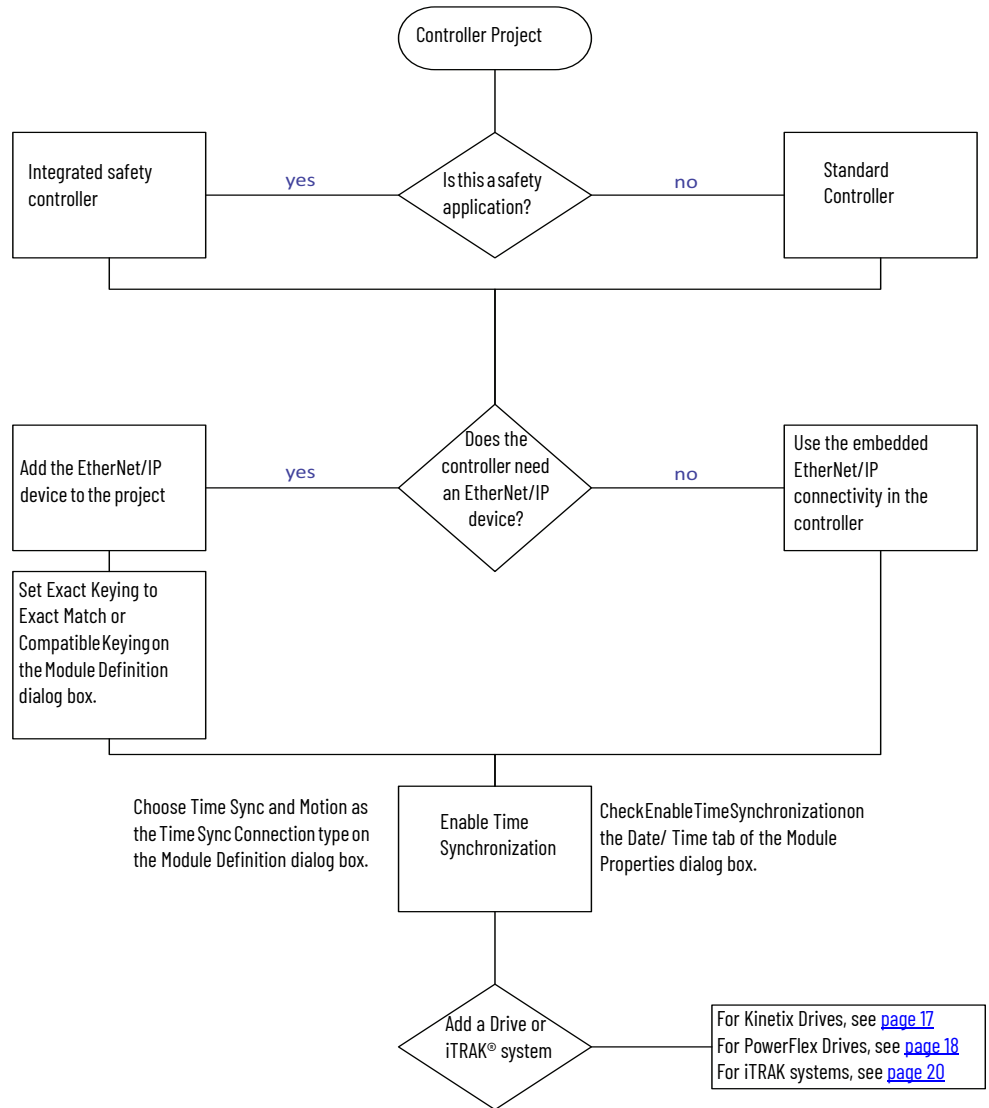

## Add a Kinetix Drive

The available configuration options differ depending on the controller and drive type that you chose for your project. Before you begin, verify that you have the correct minimum software, firmware, and Add-on Profile versions. See [Chapter 1](#).

See the drive manuals that are listed in the [Additional Resources on page 9](#) for detailed information on drive configuration and operation.

[Figure 2](#) shows the path for configuring a Kinetix drive in a motion project.

**Figure 2 - Add and Configure a Kinetix Drive**

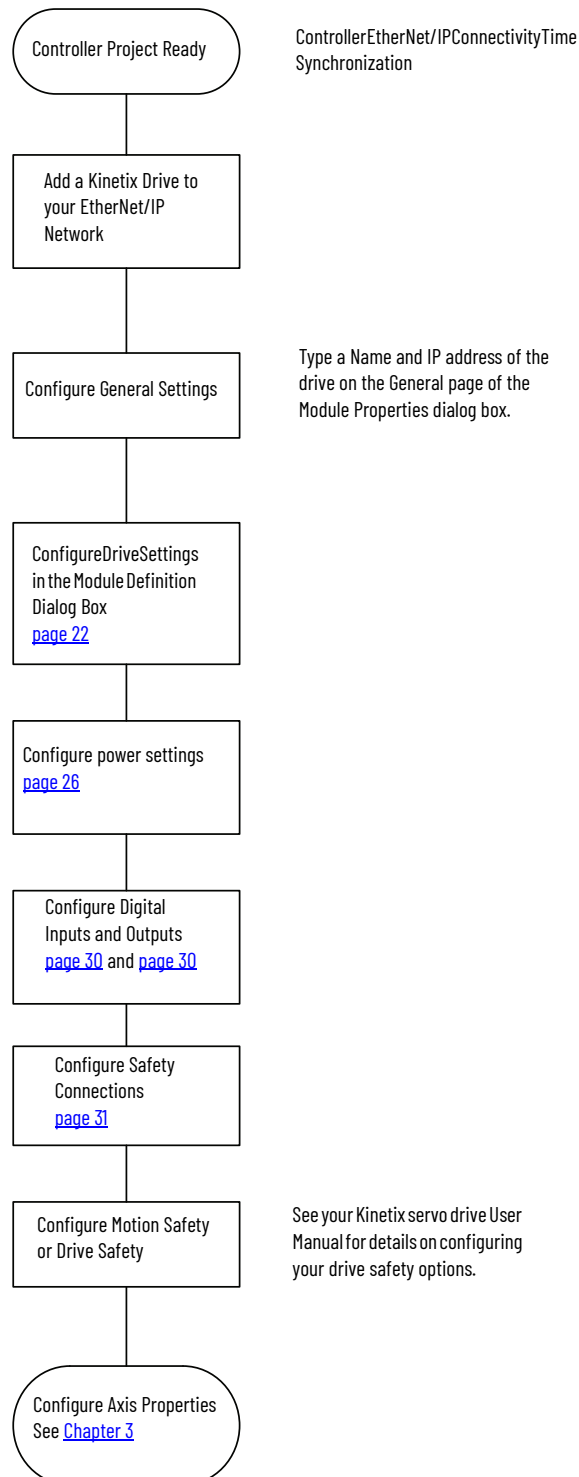

# Add a PowerFlex Drive

The available configuration options differ depending on the controller, drive type, and PowerFlex option modules you chose for your project.

[Figure 3](#) shows the path for configuring a PowerFlex drive in a motion project.

**Figure 3 - Add and Configure a PowerFlex 755, PowerFlex 755T, or PowerFlex 527 Drive**

- Choose a PowerFlex 755 drive catalog number that ends in -CM or -CM-Sx for an Integrated Motion Drive.
- Choose a PowerFlex 755T drive catalog number that ends in -CM for an Integrated Motion Drive.

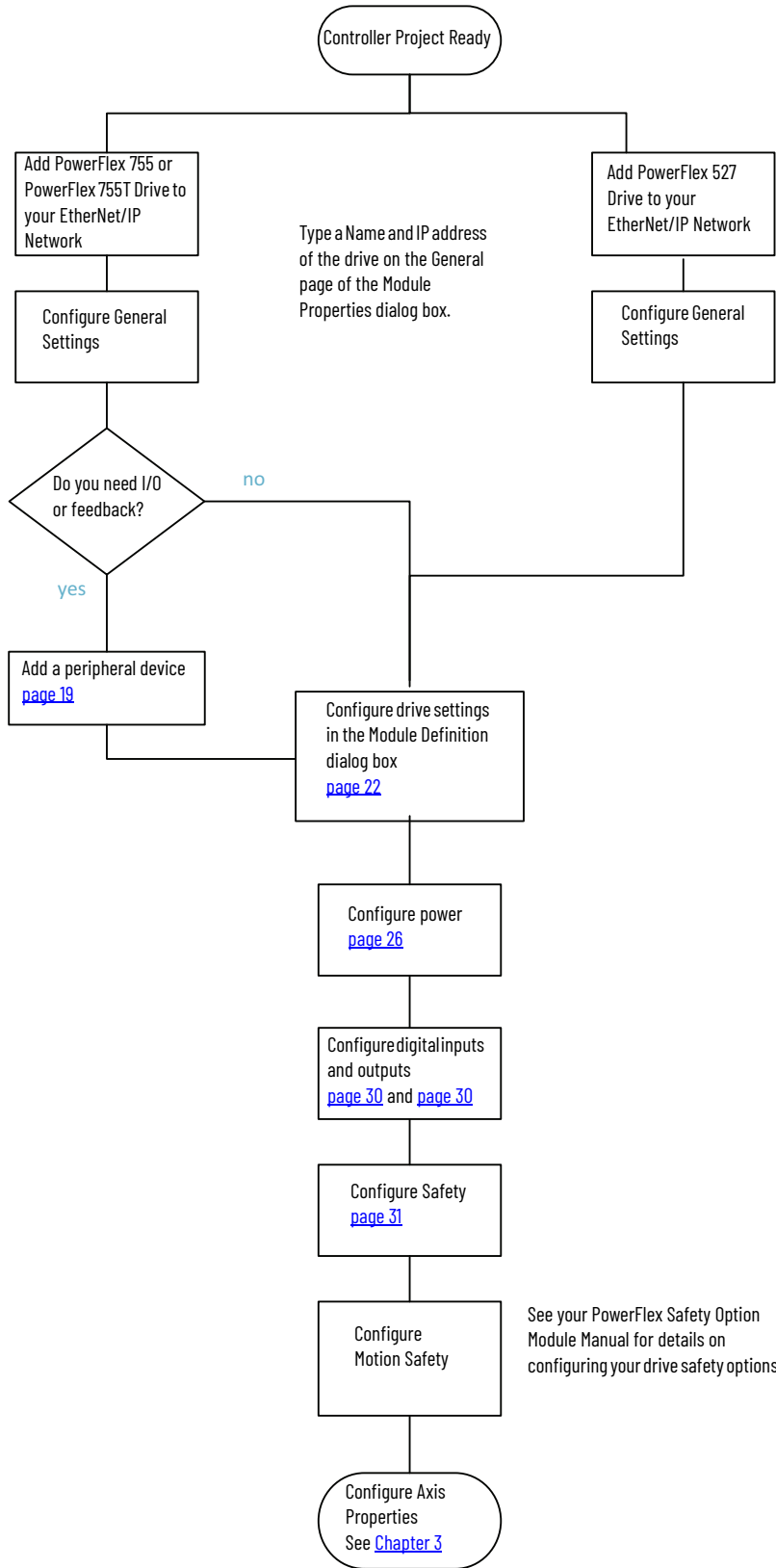

## Add a Peripheral Device for PowerFlex 755 Drives

To add a peripheral device to your drive for I/O or feedback, follow these steps.

1. On the General tab of the Module Properties dialog box, click Change to open the Module Definition dialog box.
2. Edit the Revision, if necessary.

For PowerFlex 755 drives, you must select a revision of 12 or later to add an I/O module to port 7 as a peripheral device.

3. Right-click your drive and choose New Peripheral Device.

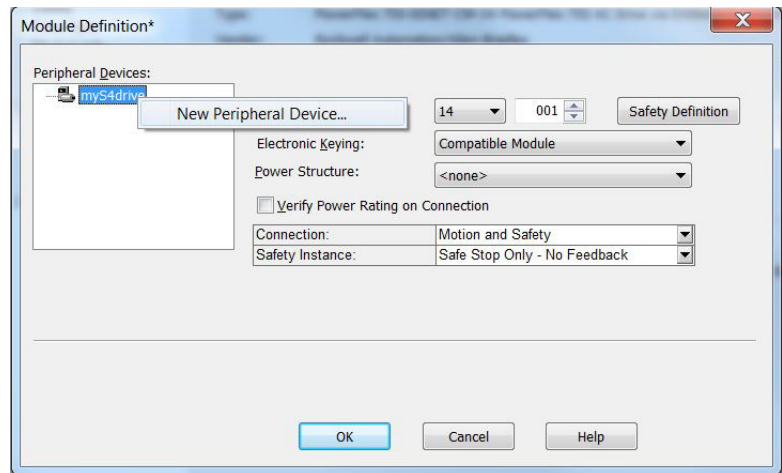

4. Select a port for your device.



If you are adding a safety option module and a feedback option module, add the safety option module first. After adding the safety option module, then select a connection type of Safety only or Motion and Safety before adding your feedback option module. See [Connection Types](#) for more information.

Follow these guidelines for port assignment:

- The Integrated Safety Functions option module and the feedback device must be installed on the same backplane using ports 4, 5, or 6.
- When used in an Integrated Motion application, the Integrated Safety Functions option module must be installed in port 6.
- Only one safety option module can be installed in a drive. Multiple safety options or duplicate safety option installations are not supported.

These feedback module combinations are supported.

Option	Supported Module	Catalog Number	Valid Ports
Two Feedback Options	Single Incremental Encoder	20-750-ENC-1	4...8 <sup>(1)</sup>
	Dual Incremental Encoder	20-750-DENC-1	4...8 <sup>(1)</sup>
	Universal Feedback Card	20-750-UFB-1	4...6
Two Feedback Options and One Safety Option	Single Incremental Encoder	20-750-ENC-1	4 and 5
	Dual Incremental Encoder	20-750-DENC-1	4 and 5
	Universal Feedback	20-750-UFB-1	4 and 5
	Safe Torque Off, or Safe Speed Monitor <sup>(2)</sup> , or Integrated Safe Torque Off, or Integrated Safety Functions <sup>(2)</sup>	20-750-S 20-750-S1 20-750-S3 20-750-S4	6

(1) Use ports 7 and 8 when using 20-750-ENC-1 or 20-750-DENC-1 modules.

(2) The Safe Speed Monitor option module must be used with the 20-750-DENC-1 Dual Incremental Encoder module or the 20-750-UFB-1 Universal Feedback module.

5. If you are using a feedback option module for safe feedback with a 20-750-S4 safety option, click the Safe Feedback checkbox.
6. If your drive is equipped with an integrated safety option module (20-750-S3 or 20-750-S4), click Safety Definition to define the Major and Minor Revisions and Electronic Keying options.

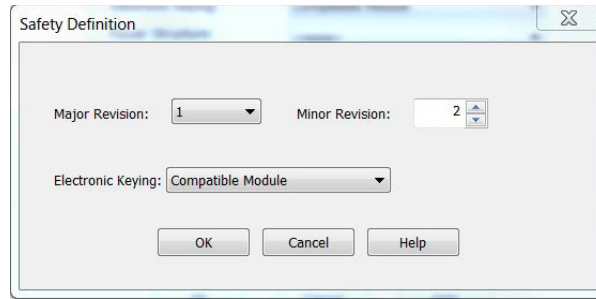

When you are using integrated safety modules, you can set the electronic keying to either Exact Match or Compatible Keying.

7. Continue with [Configure Module Definition on page 22](#).

## Add an iTRAK Section, Mover, or Power Supply

The available configuration options differ depending on the controller and iTRAK device type you chose for your project. Before you begin, verify that you have the correct minimum software, firmware, and Add-on Profile versions. See [Chapter 1](#).

[Figure 4](#) shows the path for configuring an iTRAK section, mover, or power supply in an integrated motion project.

If you are using an iTRAK power supply, add the module to the project under the same controller as the iTRAK sections and the Kinetix 5700 power supply (either the regenerative power supply or the DC Bus supply).

If using the iTRAK system, each section is automatically assigned an IP address by the iTRAK backplane, in sequential order from the first iTRAK module added to the project.

Figure 4 - Add iTRAK Drive Modules

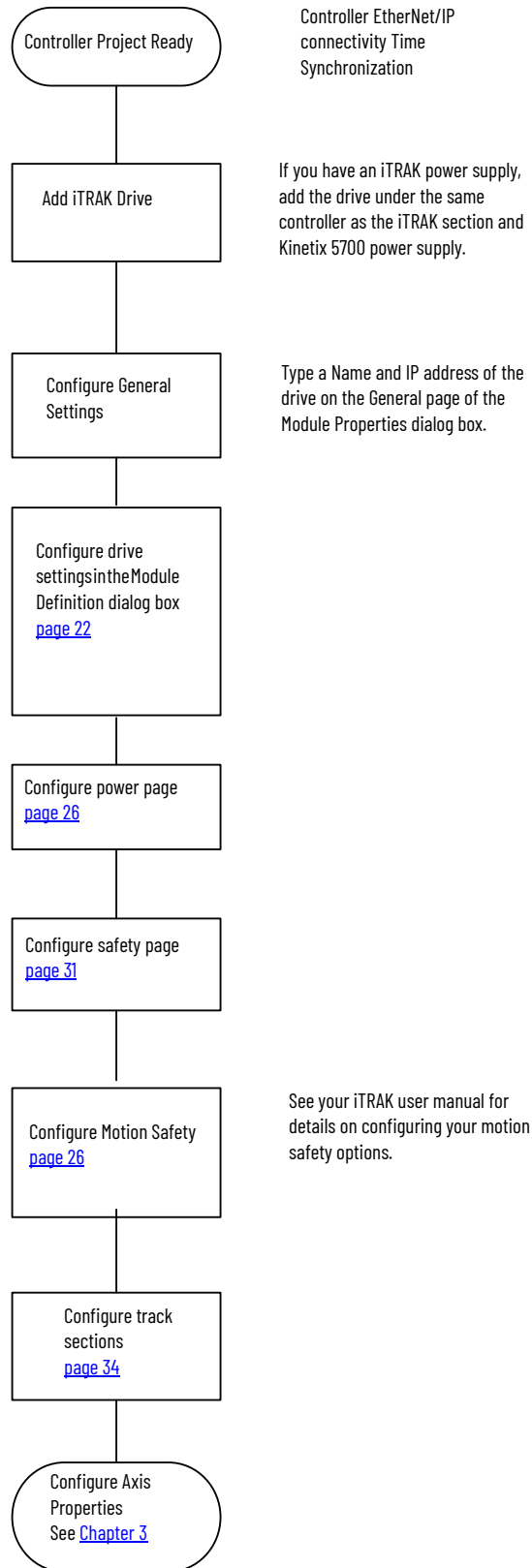

## Configure Module Definition

All drives let you update the drive Revision, choose an Electronic Keying type, and choose a Power Structure. Options for Connection type and other fields depend on the type of drive you added to your project. See [Table 3 on page 22](#).



**ATTENTION:** The electronic keying feature automatically compares the expected module, as shown in the configuration tree, to the physical module before communication begins.

When you are using devices in an integrated motion application, set the electronic keying to either Exact Match or Compatible Keying.

**Never** use Disable Keying with motion or safety modules.

For more information about electronic keying, see the Electronic Keying in Logix 5000™ Control Systems Application Technique, publication [LOGIX-AT001](#).

**Table 3 - Module Definition Fields - Kinetix, ArmorKinetix, and iTRAK**

	Kinetix 350, Kinetix 5300, Kinetix 5500, and Kinetix 6500 Servo Drives	Kinetix 5700 DC - Bus Supply Kinetix 5700 Regenerative Bus Supply	Kinetix 5700 Inverter	ArmorKinetix DSD	ArmorKinetix DSM	iTRAK 5730	
Revision	X	X	X <sup>(1)</sup>	X	X	X	Update the Revision, if necessary.
Electronic Keying	X	X	X	X	X	X	Choose Exact Match or Compatible Keying.
Power Structure <sup>(2)</sup>	X	X	X	X	X	X	Assign a power structure, if necessary. <sup>(3)</sup>
Safety Application	—	—	X	X	X	X	See <a href="#">Safety Application Types on page 24</a>
Connection	X	X	X	X	X	X	See <a href="#">Connection Types on page 25</a> .
Safety Instance	—	—	—	—	—	—	See <a href="#">Safety Instance on page 25</a>
Motion Safety	—	—	X	X	X	X	See <a href="#">Motion Safety Type on page 26</a>
Motion Safety 1	—	—	X	—	—	—	
Motion Safety 2	—	—	X	—	—	—	

(1) For 2198-xxxx-ERS3 series A drives, the firmware revision is 7 or earlier. For 2198-xxxx-ERS3 series B and later drives, the firmware revisions are 9 or later.

(2) Power structure only is selectable for the Kinetix 6500, PowerFlex 755, and PowerFlex 527 drives. The other product power structures are selected with the AOP.

(3) Locate the power structure reference numbers by checking the device hardware, reviewing the product documentation, checking the purchase order, or reviewing the bill of materials.

**Table 4 - Module Definition Fields - PowerFlex**

	PowerFlex 755 Drive with Embedded Ethernet	PowerFlex 755 Drive with Safe Torque Off	PowerFlex 755 Drive with Safe Speed Monitoring	PowerFlex 755 Drive with Integrated Safe Torque Off	PowerFlex 755 Drive with Integrated Safety Functions	PowerFlex 527 Drive	
	PowerFlex 755 Hi-Power Drive with Embedded Ethernet	PowerFlex 755 Hi-Power Drive with Safe Torque Off (with 20-750-S option module installed)	PowerFlex 755 Hi-Power Drive with Safe Speed Monitoring (with 20-750-S1 option module installed)	PowerFlex 755 Hi-Power Drive with Integrated Safe Torque Off (with 20-750-S3 option module installed)	PowerFlex 755 Hi-Power Drive with Integrated Safety Functions (with 20-750-S4 option module installed)		
Revision	X <sup>(1)</sup>	X <sup>(1)</sup>	X <sup>(1)</sup>	X <sup>(1)</sup>	X <sup>(1)</sup>	X	Update the Revision, if necessary.
Electronic Keying	X	X	X	X	X	X	Choose Exact Match or Compatible Keying.
Power Structure <sup>(2)</sup>	X	X	X	X	X	X	Assign a power structure, if necessary. <sup>(3)</sup>
Safety Application	—	—	—	—	—	—	See <a href="#">Safety Application Types on page 24</a>
Connection	X	X	X	X	X	X	See <a href="#">Connection Types on page 25</a> .
Safety Instance	—	—	—	—	X	—	See <a href="#">Safety Instance on page 25</a>
Motion Safety	—	—	—	—	—	—	See <a href="#">Motion Safety Type on page 26</a>
Motion Safety 1	—	—	—	—	—	—	
Motion Safety 2	—	—	—	—	—	—	

(1) For PowerFlex 755 drives, you must select a revision of 12 or later to add an I/O module to port 7 as a peripheral device.

(2) Power structure only is selectable for the Kinetix 6500, PowerFlex 755, and PowerFlex 527 drives. The other product power structures are selected with the AOP.

(3) Locate the power structure reference numbers by checking the device hardware, reviewing the product documentation, checking the purchase order, or reviewing the bill of materials.

Table 5 - Module Definition Fields - PowerFlex 755T Drives

	PowerFlex 755TL AC Drive - CIP Motion	PowerFlex 755TM Common Bus Inverter - CIP Motion	PowerFlex 755TM Regenerative Bus Supply - CIP Motion	PowerFlex 755TR AC Drive - CIP Motion	PowerFlex 755TS AC Drive - CIP Motion	
Revision	X <sup>(1)</sup>	X <sup>(1)</sup>	X <sup>(1)</sup>	X <sup>(1)</sup>	X <sup>(1)</sup>	Update the Revision, if necessary
Electronic Keying	X	X	X	X	X	Choose Exact Match or Compatible Keying
Power Structure <sup>(2)</sup>	X	X	X	X	X	Assign a power structure, if necessary <sup>(3)</sup>
Safety Application	—	—	—	—	—	See <a href="#">Safety Application Types on page 24</a>
Connection	X	X	X	X	X	See <a href="#">Connection Types on page 25</a>
Predictive Maintenance	X	X	X	X	X	See publication <a href="#">750-AT007</a>
Safety Instance	—	—	—	—	X	See <a href="#">Safety Instance on page 25</a>
Motion Safety	—	—	—	—	—	See <a href="#">Motion Safety Type on page 26</a>
Motion Safety 1	—	—	—	—	—	
Motion Safety 2	—	—	—	—	—	

(1) For PowerFlex 755 drives, you must select a revision of 12 or later to add an I/O module to port 7 as a peripheral device.

(2) Power structure only is selectable for the Kinetix 6500, PowerFlex 755, and PowerFlex 527 drives. The other product power structures are selected with the AOP.

(3) Locate the power structure reference numbers by checking the device hardware, reviewing the product documentation, checking the purchase order, or reviewing the bill of materials.

Figure 5 - Example Module Definition Dialog Boxes

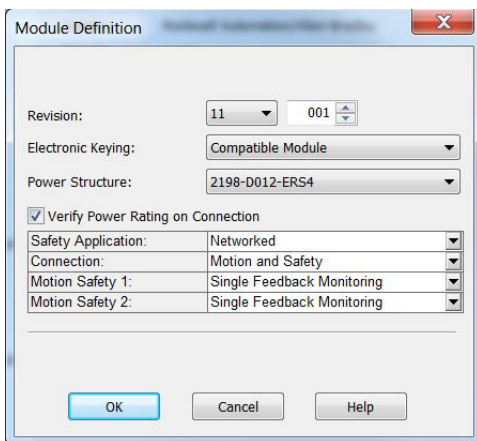

Kinetix 5700 Drive with Integrated Safety

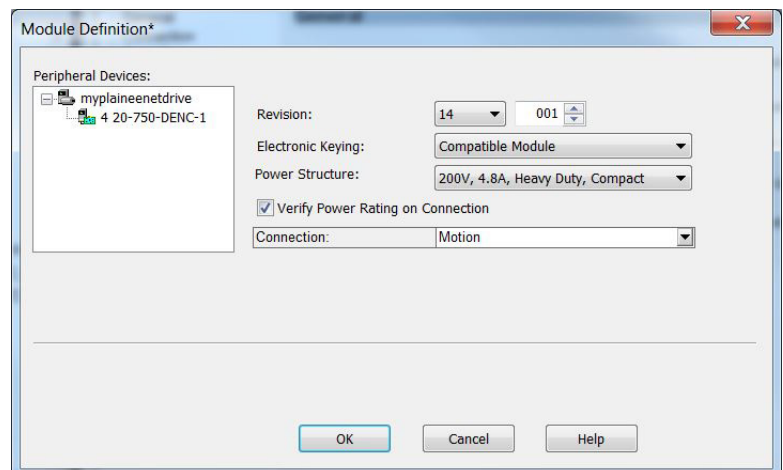

PowerFlex 755 Drive with Embedded Ethernet

## Safety Application Types

The Safety Application dropdown menu lets you choose between Hardwired for Hardwired STO mode or Networked for a Kinetix 5700 integrated safety application or iTRAK 5730 integrated safety. [Table 6](#) defines the choices and which Connection Types are available based on your choice of Safety Application mode.

**Table 6 - Safety Application Definitions**

Safety Application Mode	Safety Functions	Minimum Module <sup>(1)</sup> Required	Connection Types	Compatible Controllers <sup>(2)</sup>
Hardwired	Safe Torque Off (STO)	2198-xxxx-ERS3 (series A) 2198-xxxx-ERS3 (series B or later)	• Motion Only	• ControlLogix® 5570/5580 • CompactLogix™ 5370/5380 • GuardLogix 5570/5580 • Compact GuardLogix 5370/5380
	Safe Torque Off (STO)	2198-xxxx-ERS3 (series A)	• Motion and Safety • Safety Only	• GuardLogix 5570/5580
Networked (integrated)	Safe Torque Off (STO)	iTRAK 5730	• Motion and Safety • Safety Only	• GuardLogix 5580
	Safe Torque Off (STO)	2198-DSx-ERS2 or -ERS5	• Motion and Safety • Safety Only • Safety Networked (Integrated) • Motion Only • Networked (Integrated) and select Safety Only	• GuardLogix 5570 • Compact GuardLogix 5370
	Timed SS1	2198-xxxx-ERS3 (series B or later) iTRAK 5730 2198-DSx-ERS2 or -ERS5	• Motion and Safety • Safety Only	• GuardLogix 5580 • Compact GuardLogix 5380
	• Timed SS1 • Monitored SS1 • Controller-based safety functions <sup>(3)</sup>	2198-xxxx-ERS4 2198-DSx-ERS5	• Motion and Safety • Safety Only	
Safety Off	• none	2198-DSx-ERS2 or -ERS5	• Motion Only	• ControlLogix 5570/5580 • CompactLogix 5370/5380 • GuardLogix 5570/5580 • Compact GuardLogix 5370/5380

(1) Where a 2198-xxxx-ERS3 drive is specified, a 2198-xxxx-ERS4 drive is backwards compatible. Where a 2198-xxxx-ERS3 (series A) drive is specified, a 2198-xxxx-ERS3 (series B) drive is backwards compatible.  
 (2) Where a ControlLogix or CompactLogix (non-safety) controller is specified, a GuardLogix or Compact GuardLogix controller is backwards compatible. Also, GuardLogix 5580 and Compact GuardLogix 5380 controllers are backwards compatible with GuardLogix 5570 and Compact GuardLogix 5370 controllers.  
 (3) See the Kinetix 5700 Safe Monitor Functions Safety Reference Manual, publication [2198-RM001](#), for more information on these Drive Safety instructions.

## Connection Types

Choose the connection type for your drive.

**Table 7 - Module Connection Definitions**

Connection Type	Used with the Following Safety Options	Description
Motion and Safety	<ul style="list-style-type: none"> <li>Integrated safety</li> </ul>	<ul style="list-style-type: none"> <li>Motion connections and integrated safety are managed by this controller.</li> </ul>
Motion Only <sup>(1)</sup>	<ul style="list-style-type: none"> <li>Hardwired Safe Torque Off mode</li> <li>Integrated safety, if there is a secondary safety controller</li> </ul>	<ul style="list-style-type: none"> <li>Motion connections are managed by this controller.</li> <li>Hardwired STO is controlled by the hardwired safety inputs or integrated safety is managed by another controller that has a Safety-only connection to the drive.</li> </ul>
Safety Only	<ul style="list-style-type: none"> <li>Integrated safety</li> </ul>	<ul style="list-style-type: none"> <li>Integrated safety is managed by this controller.</li> <li>Motion connections are managed by another controller that has a Motion only connection to the drive.</li> </ul>

(1) The ArmorKinetic DSD and DSM modules do not have hardwired safety connections.

For Motion and Safety or Safety selections, additional configuration and considerations that are not covered in this manual apply. See the publications for your drive, PowerFlex 750-series safety option module, and safety controller, which are listed in the [Additional Resources on page 9](#).

### IMPORTANT

For Logix Designer application version 35, drives with axes using the Axis Test Mode feature provide only limited support for Safety Connections. When the feature is used, the Axis Safety State for the Safety Connection axis with 'Axis Test Mode' is set as 'Unknown (No Motion Connection)' at the end of the configuration.

Logix Designer application version 36 added motion and safety simulation for CIP Safety™ drives.

## Safety Instance

For PowerFlex drives with a 20-750-S4 option module installed and a connection type of Motion and Safety or Safety only, you can choose a Safety Instance. A 20-750-UFB-1 or 20-750-DENC-1 feedback module with Safe Feedback checked is required for Single or Dual Feedback monitoring choices to be available.

See the PowerFlex 755/755T Integrated Safety Functions Option Module User Manual, publication [750-UM005](#), for more information.

**Table 8 - Safety Instance Definitions**

Safety Instance Mode	Description
Safe Stop 1 Only - No Feedback	STO function and Timed SS1 Safe Stop 1 functions are available.
Single Feedback Monitoring	Primary feedback is used in the safety object for safe monitoring.
Dual Feedback Monitoring	In addition to primary feedback, an external feedback device is used to provide error checking of the primary feedback device. A secondary encoder is considered part of the encoder diagnostics and the data that it produces is not rated safety data.

## Motion Safety Type

When the Connection type is Motion and Safety or Safety only and the Safety Application mode is Networked, you can choose a Motion Safety Type.

**Table 9 - Motion Safety Definitions**

Motion Safety Mode	Description
STO Only	STO function only.
Safe Stop 1 Only - No Feedback	STO function and Timed SS1 Safe Stop 1 functions are available.
Single Feedback Monitoring	Primary feedback is used in the safety object for safe monitoring. The feedback can be a SIL rated Hiperface DSL encoder, for example, a VPL-B1003P-Q or W motor used in the DSL Feedback port. This feedback can also be a Sine/Cosine or EnDat device, for example, an MPL-B310P-M motor used in the Universal Feedback port.
Dual Feedback Monitoring	In addition to primary feedback, an external feedback device is used to improve SIL levels. For example, the Bulletin 842HR type encoder can be used in the Universal Feedback port as a Sine/Cosine device.

See the Kinetix 5700 Safe Monitor Functions Safety Reference Manual, publication [2198-RM001](#), to evaluate SIL levels possible with one feedback device or two feedback devices.

## Axis Test Mode

When an Axis that is associated with the Safety Drive is configured for Axis Test Mode, no Safety Connection is established.

## Configure Power Settings

The Power page lets you configure the drive Bus Configuration, assign a Bus Sharing Group, set Bus Regulator Action or select a Shunt Resistor Type and configuration limits. The options for configuration differ depending on drive type.

Consider the following when choosing the appropriate settings for your application.



**ATTENTION:** To avoid damage to equipment, all modules that are physically connected to the same shared-bus connection system must be part of the same bus-sharing Group in the Studio 5000 Logix Designer application.

- The Logix Designer application enforces shared-bus configuration rules for Kinetix drives, except for shared AC configurations.
- Kinetix 5500 drives with single-phase operation are limited to 2198-H003-ERSx, 2198-H008-ERSx, and 2198-H015-ERSx.
- Single-phase operation is possible only when Module Properties > Power tab > Bus Configuration is configured as Standalone and Voltage is configured as 200...240V AC.



**ATTENTION:** To avoid damage to equipment, make sure the AC input voltage that is configured in the Logix Designer application matches the actual hardware being configured.

Figure 6 - Power Configuration Example Pages

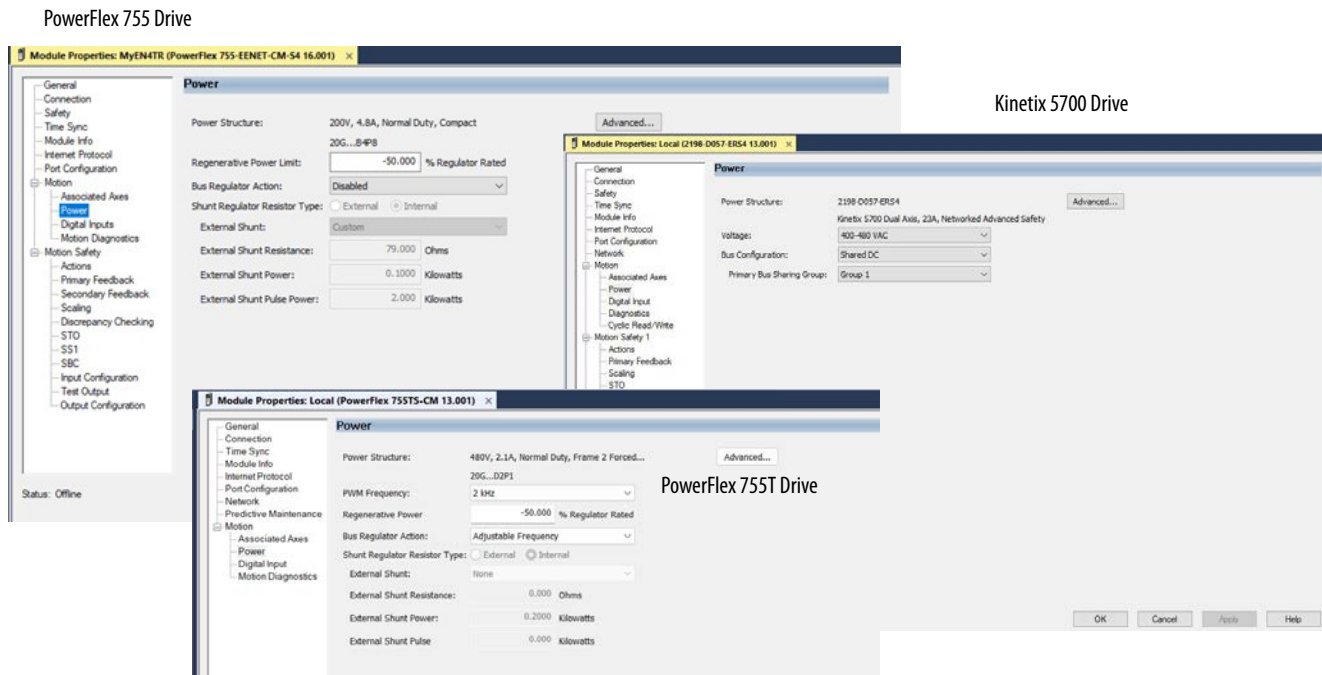

1. Choose the appropriate power settings for your application, see [Table 10](#).

For PowerFlex 755T power setting information, see *Integrated Motion on EtherNet/IP Networks for PowerFlex Drives with TotalFORCE® Application Technique*, publication [750-AT007](#).

Table 10 - Power Settings

Attribute	Settings	Description
Voltage	400...480 VAC	324...528 AC rms input voltage
	200...240 VAC	195...264 AC rms input voltage
PWM Frequency	1.33 kHz 2 kHz 4 kHz (Default) 8 kHz 12 kHz	The value sets the carrier frequency for the pulse-width modulation (PWM) output to the motor.
AC Input Phasing	<ul style="list-style-type: none"> <li>• Three-phase</li> <li>• Single-phase</li> </ul>	Input power phasing. Single-phase operation is not available for all drives. For more information on the power options that are available, see the user manual for your product.
Bus Configuration	Shared AC/DC <sup>(1)</sup>	Applies to 2198-Pxxx DC-bus power supply (converter) modules. Can also apply to 2198-H008-ERSx modules.
	Standalone	Applies to single-axis drives and drives with Shared AC input configurations, for example, 2198-H008-ERSx modules.
	Shared DC	Indicates that the converter section of the drive supplies DC Bus power only to this drive's power structure.
	Shared DC/DC	Applies to inverter drives with Shared DC input (common-bus) configurations. Default selection for iTRAK power supply modules.
Regenerative Power Limit	Settings are specific to each device.	This limit is the amount of energy that the drive allows during regeneration. If an external regenerative power supply or shunt (dynamic brake) resistor is used, it is recommended that this value is set to -200.0%. <b>IMPORTANT:</b> If this value is set too low, the ability of the drive to stop a motor is limited.
Bus-sharing Group <sup>(2)</sup>	Group number	Applies to any bus-sharing configuration.

Table 10 - Power Settings (Continued)

Attribute	Settings	Description
Bus Regulator Action	Disabled	Disables the internal shunt resistor and external shunt option.
	Shunt Regulator	Enables the internal and external shunt options.
	Adjustable Frequency <sup>(3)</sup>	This selection allows the drive to either change the torque limits or ramp rate of the velocity to control the DC bus voltage. This option is not recommended for positioning applications because it overrides the velocity and the system can overshoot or not stop.
	Shunt then Adjustable Frequency	This selection allows the Shunt resistor to absorb as much energy as it is designed for, then transitions to adjustable frequency control if the limit of the resistor has been reached.
	Adjustable Frequency then Shunt	This selection allows for adjustable frequency control of the DC bus. If adjustable frequency control cannot maintain the DC bus within limits, the shunt resistor is activated.
	Common Bus Follower <sup>(4)</sup>	To configure your Kinetix 6500 IAM power module as a common-bus follower IAM module.
Shunt Regulator Resistor Type	Internal	Enables the internal shunt (the external shunt option is disabled).
	External	Enables the external shunt (the internal shunt option is disabled).
External Shunt	<ul style="list-style-type: none"> <li>• None</li> <li>• Shunt catalog number<sup>(5)</sup></li> <li>• Custom<sup>(6)</sup></li> </ul>	Selects external shunt option.
External Shunt Resistance	Valid values are determined by the type of drive.	Specifies the external shunt resistance in Ohms. Available only if the External Shunt is set to Custom.
External Shunt Power	Valid values are determined by the type of drive.	Specifies the external shunt power in Kilowatts. Available only if the External Shunt is set to Custom.
External Shunt Pulse Power	Valid values are determined by the type of drive.	Specifies the external shunt power in Kilowatts. Available only if the External Shunt is set to Custom.
Bus Capacitance	Valid values are determined by the type of drive.	Specifies the bus capacitance in microfarads (uF). Available only if the External Shunt is set to Custom.

(1) Shared AC/DC bus configuration is the default selection for 2198-Pxxx DC-bus power supplies.  
 (2) For more information on bus-sharing groups, refer to Kinetix 5700 servo drives User Manual, publication [2198-UM002](#), or the iTRAK 5730 System User Manual, [2198t-UM003](#).  
 (3) Default for PowerFlex 527 drives.  
 (4) Drive will not accept CommonBus Follower selection while three-phase power or DC bus power is applied.  
 (5) Only the shunt catalog number that is intended for the specific DC-bus power supply is shown. See the Kinetix Servo Drives Specifications Technical Data, publication [KNX-TD003](#), for more information on shunt resistors.  
 (6) Custom is only for PowerFlex 527 and 755 drives.

2. To adjust the limits for overload and voltage, Click Advanced.

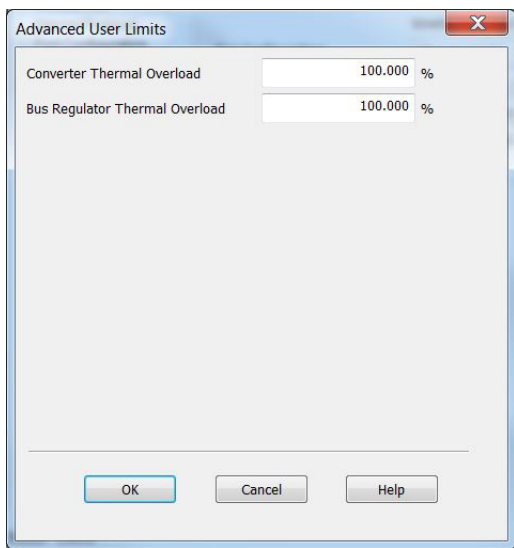

Kinetix 5700 DC Bus Supply

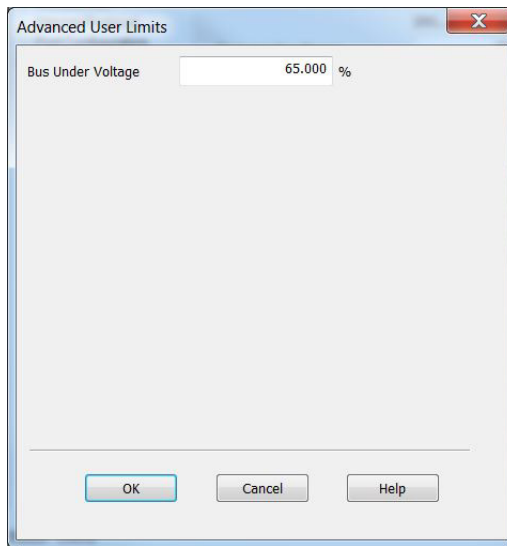

PowerFlex 755 Drive

Table 11 - Limits for Overload and Voltage

Parameter	Description
Converter Over Temperature Limit	Sets the user limit for converter over temperature.
Converter Thermal Overload Limit	Sets the user limit for converter thermal overload.
Converter Pre-charge Overload Limit	Sets the user limit for converter pre-charge overload.
Converter Ground Current Limit	Sets the user limit for the converter ground current.
Bus Input Overcurrent	Sets DC bus user limit for bus input overcurrent.
Bus Regulator Over Temperature Limit	Sets the user limit for bus regulator temperature.
Bus Regulator Thermal Overload Limit	Sets the user limit for bus regulator overload.
Bus Over Voltage Limit	Sets the user limit for bus over voltage.
Bus Under Voltage Limit	Sets the user limit for the bus under voltage.
Control Module Over Temperature Limit	Sets the user limit for the Control Module Over temperature User Limit exception.
Inverter Ground Current User Limit	Sets the user limit for the inverter ground current.

## Configure Predictive Maintenance

The Predictive Maintenance page lets you enable notifications for these PowerFlex 755T drive items:

- Fans
- Capacitors
- Power Devices
- Bearings
- Lubricants

Figure 7 - Predictive Maintenance Example Pages

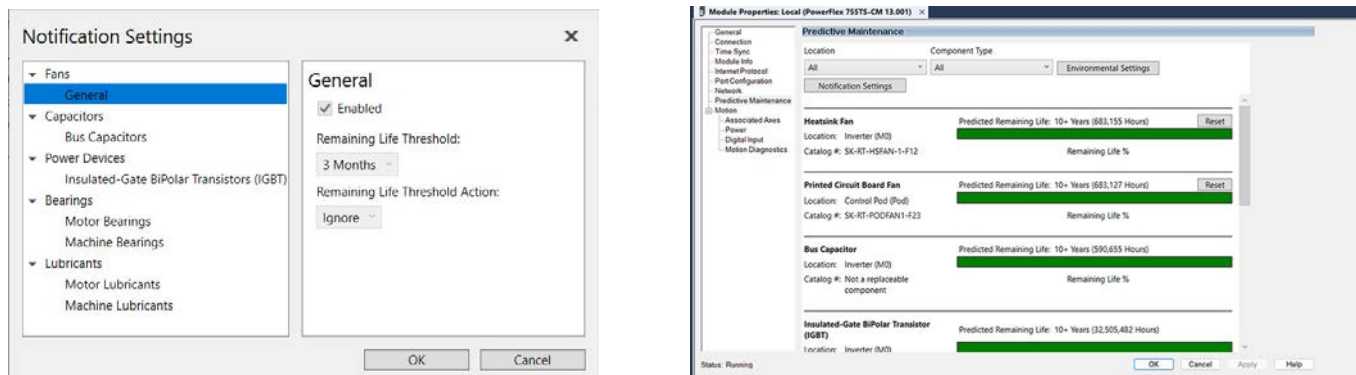

See Integrated Motion on EtherNet/IP Networks for PowerFlex Drives with TotalFORCE Application Technique, publication [750-AT007](#) for Predictive Maintenance information.

## Configure Digital Inputs

The following restrictions apply to settings made on this page:

- All digital input parameters, except Unassigned, must be unique.
- At least one Digital Input must be set to Regeneration Power OK when a module is set to the Shared DC - Non-CIP Converter bus sharing configuration in the Power tab.
- When you use the 2198-R014, 2198-R031, or 2198-R127 external passive shunt resistor with a DC-bus power supply, the Shunt Thermal Switch Digital Input must be configured.

Configure the digital inputs to monitor the status of drive functions appropriate to your application.

Table 12 - Drive Functions

Functions	Description
Enable	A 24V DC input is applied to this terminal as a condition to enable each module.
Home	An active state indicates to a homing sequence that the referencing sensor has been seen. Typically, a transition of this signal is used to establish a reference position for the machine axis.
Registration 1 Registration 2	An inactive-to-active transition (also known as a positive transition) or active-to-inactive transition (also known as a negative transition) is used to latch position values for use in registration moves.
Home	An active state indicates to a homing sequence that the referencing sensor has been seen. Typically, a transition of this signal is used to establish a reference position for the machine axis.
Positive Overtravel Negative Overtravel	The positive/negative limit switch (normally closed contact) inputs for each axis require 24V DC (nominal).
Regeneration Power OK	In the active state, the inverters can be enabled. An inactive state indicates that the bus supply unit is not ready to supply DCbus power. The inverters cannot be enabled. When a Kinetix 5700 bus group is supplied by an 8720MC-RPS unit, one inverter in the bus group must be configured in the Logix Designer application as Shared-DC Non-CIP Motion™ Converter and assigned to Regeneration OK. This signal is wired from RDY on the 8720MC-RPS unit and indicates to the Kinetix 5700 drive system that the 8720MC-RPS unit is ready to supply power. Enabled inverters enumerate a Bus Power Sharing fault if the Regeneration OK input goes inactive.
AC Line Contactor OK	An active indicates that the AC Line Contactor is working correctly.
Bus Capacitor OK	You can configure this input in the Logix Designer application and wire the module status (MS) output from the 2198-CAPMOD-2240 capacitor module to indicate to the inverter that a major fault is present on the capacitor module.
Shunt Thermal Switch OK	When the 2198-R014, 2198-R031, or 2198-R127 external shunt resistor is wired to the DC-bus power supply, this input must be configured in the Logix Designer application to monitor the status of the external shunt module thermal switch and assigned to Shunt thermal switch OK. This function does not apply to the 2198-R004 shunt resistor. You can also use this input to monitor the status of an active shunt module in the system that is connected via the capacitor module or an extension module.
Bus Conditioner OK	You can configure this input in the Logix Designer application and wire the module status (MS) output from the 2198-DCBUSCONDRP312 conditioner module to indicate to the inverter that a major fault is present on the conditioner module.
Pre-charge OK	This feature extends the precharge input monitoring capability to the PowerFlex 755 drive in integrated motion. The event processing is as follows: 1. If the configured Pre-charge OK Input becomes inactive and the drive is in the Stopped state, the drive enters the precharge state. 2. If the configured Pre-charge OK input becomes inactive and the drive is in the Running state, the drive generates the Converter Pre-charge Input Deactivated exception and performs a Fault Coast Stop.
Motor Thermostat OK	Motor thermostat input functionality is provided through the motor thermostat input (PTC) on the 22-Series I/O modules (installed in Port 7) when in Integrated Motion on EtherNet/IP mode. The functionality is the same as the motor thermostat functionality in parameter mode. When the PTC input resistance transitions from low to high at the design temperature, the drive issues a motor over temperature fault, 18 [Motor PTC Trip]. The functionality supports the current motor thermostat range for status trip and reset in parameter mode. However, this functionality is not suitable for Kinetix MPL and MPM motors due to the varying hardware capacities and thermostat ranges of the Kinetix and 22-Series I/O modules.

## Configure Digital Outputs

The Digital Outputs tab is only available for PowerFlex 755 drives with a digital I/O option card installed as a peripheral device. The appearance of the tab varies depending on the device configuration.

Configure the digital outputs appropriately for your application.

Table 13 - Digital Output Functions

Functions	Description
Unassigned	The output is not assigned.
Contactor Enable	A Contactor Enable Output can be configured in the PowerFlex 755 drive in integrated motion only. The operation of this output is tied to fault processing in the drive. The drive de-energizes the Contactor Enable Output when an exception causes the axis to go to the 'shut down' state. Note: This configuration is only valid when an auxiliary power supply is used for control power with frames 1...7 drives or when a 24 auxiliary power supply is used on frames 8...10 drives. See Drives in Common Bus Configurations with Kinetix 5700 Bus Supplies, publication <a href="#">MOTION-AT007</a> , for more information.
Mechanical Brake Engage Delay	The amount of time that the power structure remains enabled after the axis has been commanded to zero speed before disabling the power structure. The motor decelerates to a stop, the brake output actuates, and this delay provides time for the brake to engage.

## Configure Safety Settings

If your system includes a drive that supports integrated safety, note the safety network number (SNN) on the Module Properties General page, which populates automatically when you add a drive that supports integrated safety to the project.

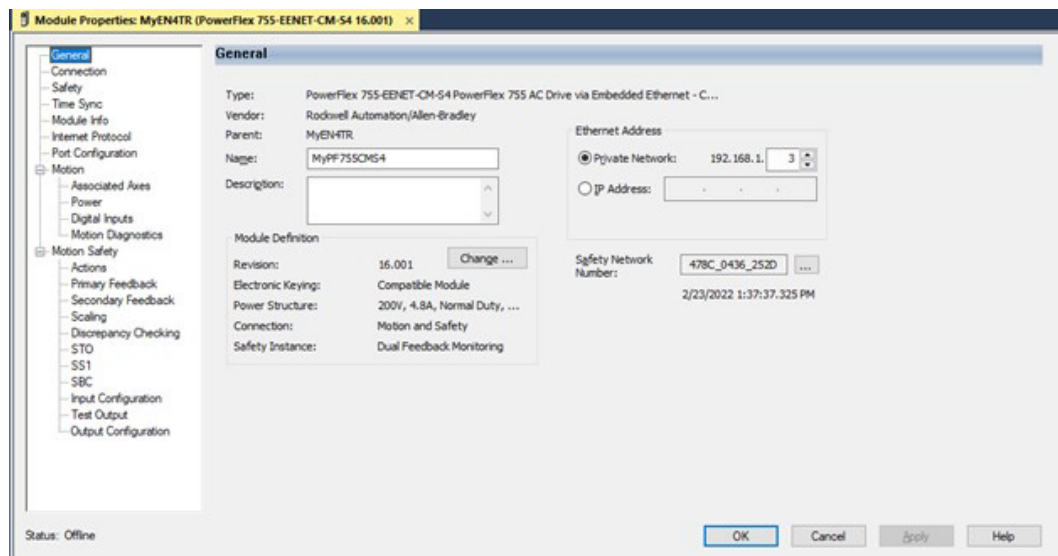

Safety network numbers for PowerFlex drives that include 20-750-S3 or 20-750-S4 option modules are unique. SNNs for other drives match the SNN of the safety controller in the project.

Often the automatically assigned SNN is sufficient, but sometimes manual configuration of the SNN is required. See [Generate the Safety Network Number \(Integrated safety drives only\) on page 33](#), your product user manual, or the GuardLogix Controller Systems Safety Reference Manual, publication [1756-RM093](#) for more information.

The connection between the owner controller and the drive is based on the following:

- Servo drive safety network number
- GuardLogix slot number
- GuardLogix safety network number
- Path from the GuardLogix controller to the drive
- Configuration signature

If any differences are detected, the connection between the GuardLogix controller and drive is lost, and the yellow yield icon appears in the controller project tree after you download the program.

## Configure Safety Connections

1. Choose the Safety page.

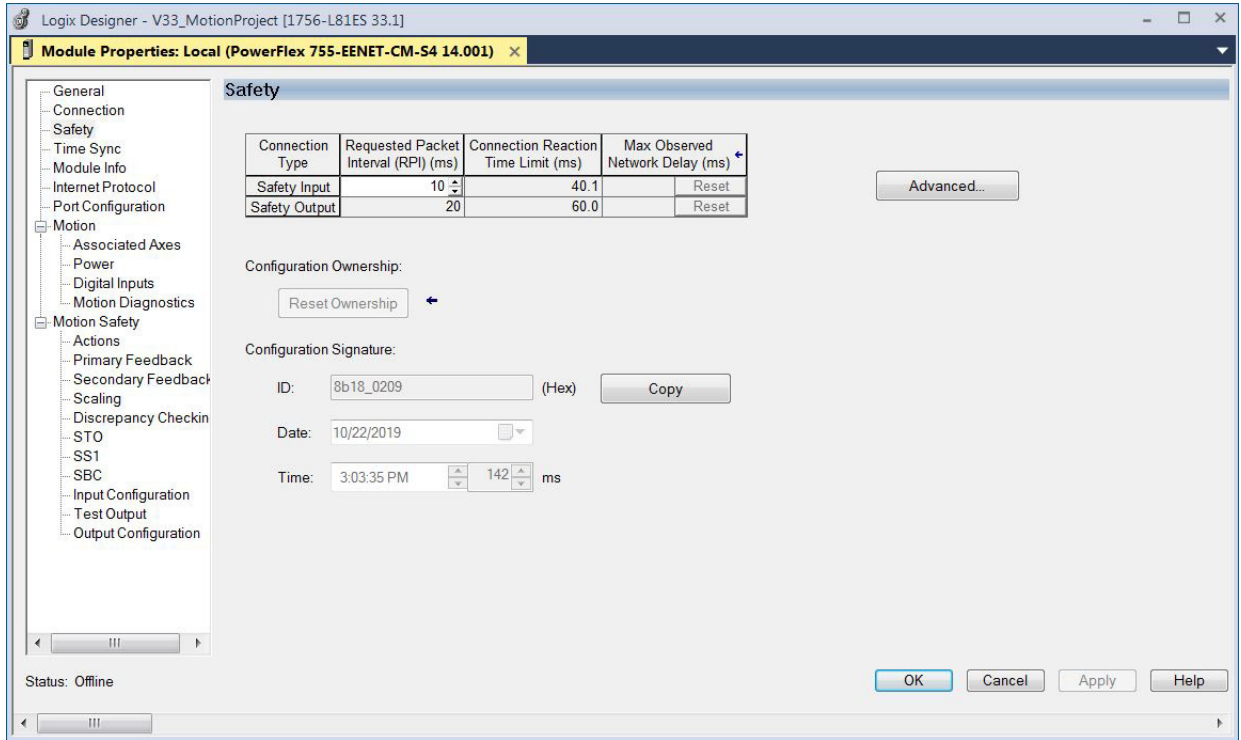

2. Click Advanced to open the Advanced Connection Reaction Time Limit Configuration dialog box.

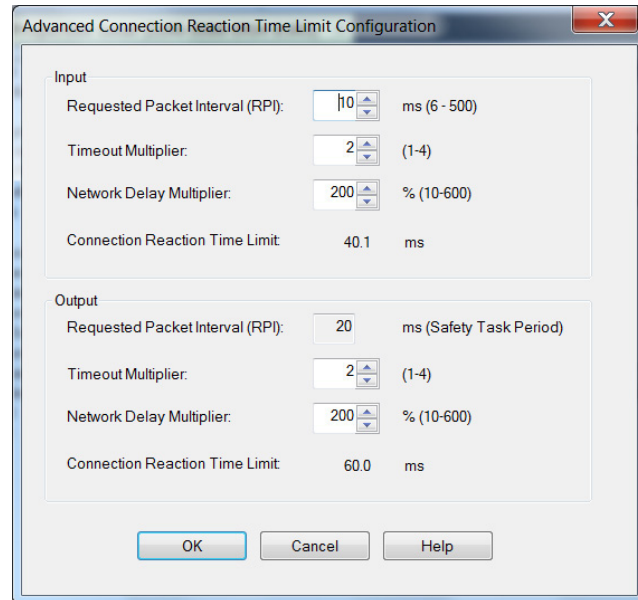

3. Analyze each safety channel to determine the appropriate settings.

The smallest Input RPI allowed is 6 ms. The selection of small RPI values consumes network bandwidth and can cause spurious trips because other devices cannot get access to the network.

For more information about the Advanced Connection Reaction Time Limit Configuration, refer to the appropriate GuardLogix or Compact GuardLogix Controllers User Manual, which is listed in [Additional Resources on page 9](#).

## Generate the Safety Network Number (Integrated safety drives only)

The assignment of a time-based safety network number (SNN) is automatic when you create a GuardLogix safety controller project and add new Safety devices. This number is sufficient. However, manual manipulation of an SNN is required in the following situations:

- If safety-consumed tags are used
- If the project consumes safety input data from a device whose configuration is owned by some other device
- If a safety project is copied to another hardware installation within the same routable safety system

If an SNN is assigned manually, the SNN has to be unique.

---

**IMPORTANT** If you assign an SNN manually, make sure that the system expansion does not result in duplication of SNN and node address combinations. A warning appears if your project contains duplicate SNN and node address combinations. You can still verify the project, but Rockwell Automation recommends that you resolve the duplicate combinations.

---

To edit the SNN, follow these steps.

1. To open the Safety Network Number dialog box, click the ellipsis to the right of the Safety Network Number.

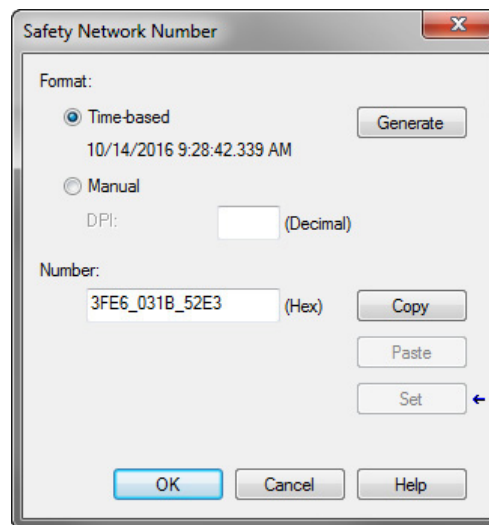

2. Select either Time-based or Manual.  
If you select Manual, enter a value from 1...9999 decimal.
3. Click Generate.
4. Click OK.

# Configure Track Sections

For iTRAK drive modules, use the following steps to configure your track.

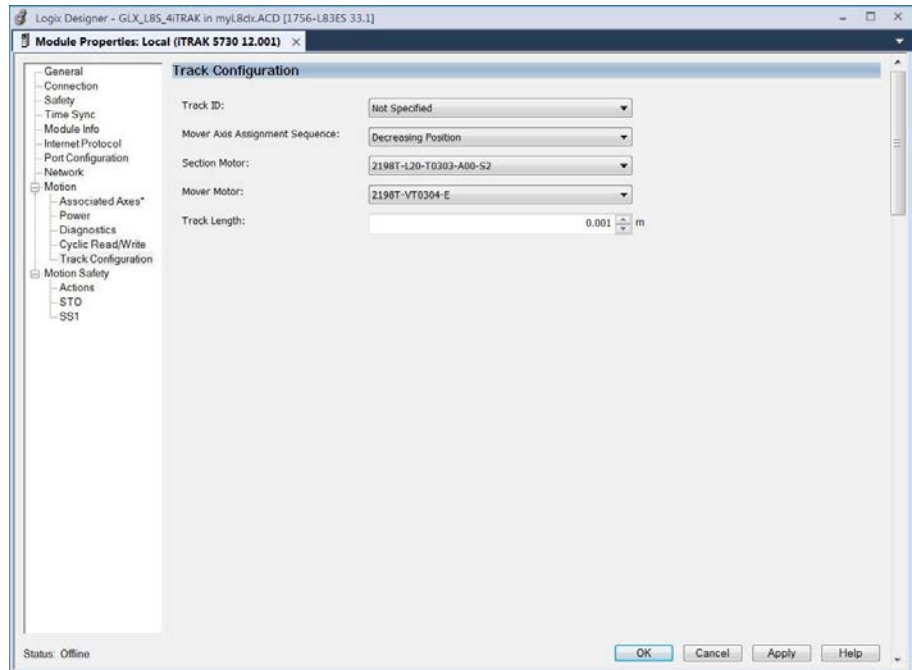

1. From the Track ID dropdown menu, select your Track ID.

**IMPORTANT**

When multiple modules share the same Track ID, these modules are identified as being configured as one Track System. This configuration allows the Logix Designer application to validate the track system as a whole. Section modules that specify a 0 or Not Specified Track ID are not validated because they are treated as standalone sections when validating track systems.

2. From the Mover Axis Assignment Sequence dropdown menu, choose the Mover Axis Assignment Sequence for your motion application.

**Table 14 - Mover Axis Assignment Sequences**

Mover Axis Assignment Sequence	Description
Decreasing Position	Track section assigns movers on the track to axis instances in a sequence starting with the mover with the highest position value as the first mover followed by movers with decreasing position values.
Increasing Position	Track section assigns movers on the track to axis instances in a sequence starting with the mover with the lowest position value as the first mover followed by movers with increasing position values.
DecreasingPositionfromReferenceMover	Track section assigns movers on the track to axis instances in a sequence starting with the mover electronically identified as the Reference Mover followed by movers in the direction of decreasing position values relative to the Reference Mover.
IncreasingPositionfromReferenceMover	Track section assigns movers on the track to axis instances in a sequence starting with the mover electronically identified as the Reference Mover followed by movers in the direction of increasing position values relative to the Reference Mover

3. From the Section Motor dropdown menu, select the section motor corresponding to your iTRAK drive module.

A curve section acts like three individual sections: curve A, curve B, and curve C. Each of the three sections must be added as a separate drive and configured individually.

- If your drive module is a straight section, then select a 2198T-L20-T0303-A00-S2 section motor
  - If your drive module is a curve A section, then select a 2198T-L20-T0309-D18-S2-A section motor
  - If your drive module is a curve B section, then select a 2198T-L20-T0309-D18-S2-B section motor
  - If your drive module is a curve C section, then select a 2198T-L20-T0309-D18-S2-C section motor
4. Enter the length of your entire track in the Track Length field.

**Notes:**

## Configure Axis Properties

### Create an Associated Axis

Before you can complete the configuration process, you must create an axis and associate it to your drive.

### Create an Axis

Follow these steps to create an axis.

1. To open the Module Properties dialog box, double-click the drive in the Controller Organizer.
2. Click the Associated Axes tab.

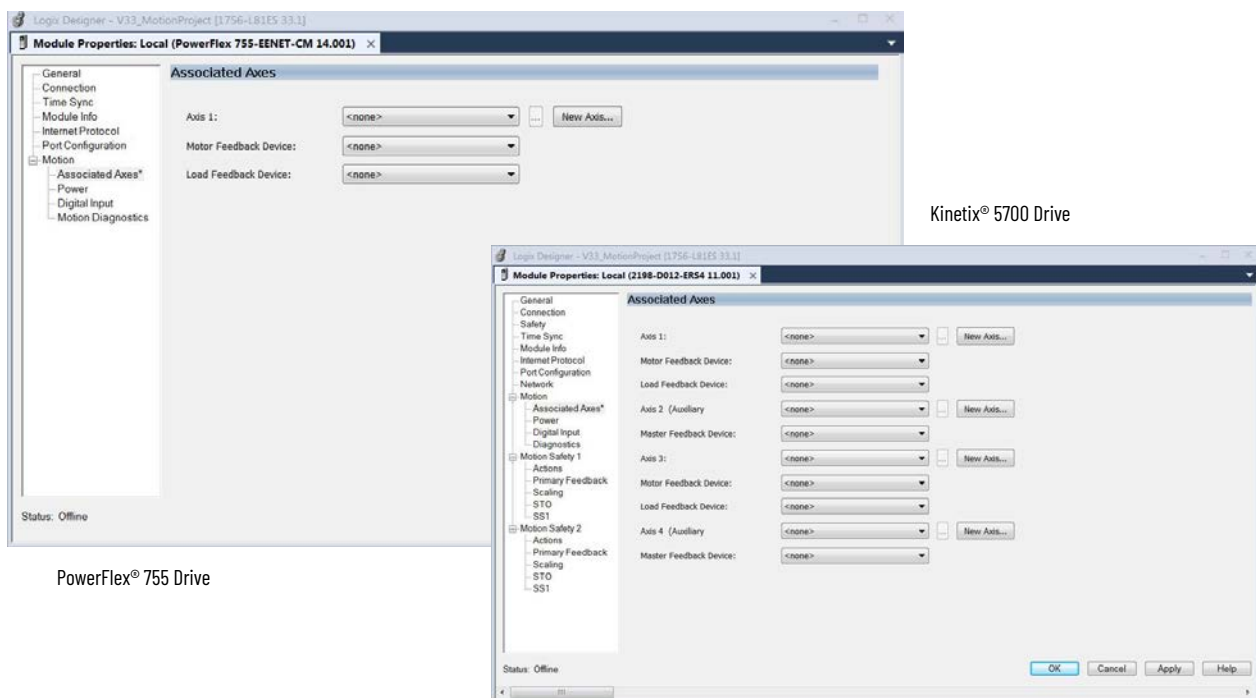

3. Click New Axis.



To use the Axis Test Mode feature, all axes that are associated with a module must have Axis Test Mode enabled. See [Axis Test Mode on page 147](#) for more information.

- On the New Tag dialog box, type a name for the axis.

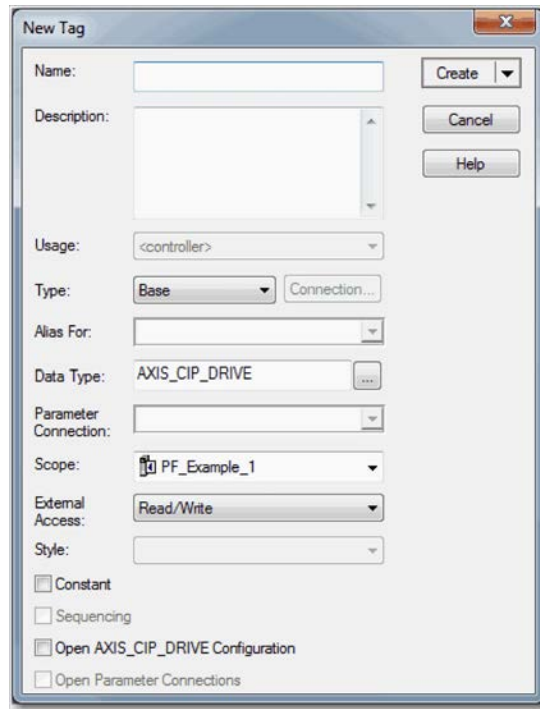

The default data type is AXIS\_CIP\_DRIVE.

For iTRAK® systems, the first axis must be the section axis. The remaining four axes can be used for mover axis or left blank depending on your application.

- Make any adjustments for your application.
- Click Create.
- Configure additional axes, if applicable.



To use the Axis Test Mode feature, all axes that are associated with a module must have Axis Test Mode enabled. See [Axis Test Mode on page 147](#) for more information.

## Specify Feedback Assignments

The type of feedback you can assign differs based on the type of drive.

**Table 15 - Drive Feedback Types**

Drive	Axis	Feedback Types
Kinetix® 350	1	Motor Feedback
Kinetix 5300	2	Axis 1 for Motor or Load Feedback Axis 2 for Auxiliary (Master) Feedback
Kinetix 5500	1	Motor Feedback
Kinetix 6500	2	<ul style="list-style-type: none"> <li>Port 1 is reserved for Motor Feedback on the primary axis (Axis_1)</li> <li>Port 2 can be used either as a Load Feedback for the primary axis or as a Master Feedback for a secondary feedback only axis (Axis_2)</li> </ul>
Kinetix 5700 Single-axis Inverter (2198-Sxxx-ERSx)	2	Axis 1 for Motor or Load Feedback Axis 2 for Auxiliary (Master) Feedback
Kinetix 5700 Dual-axis Inverter (2198-Dxxx-ERSx)	4	Axis 1 and 3 for Motor and/or Load Feedback Axis 2 and 4 for Auxiliary (Master) Feedback
Kinetix 5700 DC-bus power supply Kinetix 5700 Regenerative Power Supply	1	No Feedback
2198T iTRAK Power Supply	1	No Feedback
ArmorKinetix® DSM (2198-DSMxxx-ERSx)	–	Motor Feedback
ArmorKinetix DSD (2198-DSDxxx-ERSx)	–	Axis 1 for Motor and/or Load Feedback Axis 2 for Auxiliary (Master) Feedback

Table 15 - Drive Feedback Types (Continued)

Drive	Axis	Feedback Types
iTRAK 5370 Section	1	Integrated Track Feedback
iTRAK 5370 Mover	4	Integrated Track Feedback
PowerFlex® 527	1	Motor Feedback
PowerFlex 755 and PowerFlex 755T drive products with 20-750-ENC-1 feedback module	1	Configure the Port channel A for Motor Feedback or Load Feedback
PowerFlex 755 and PowerFlex 755T drive products with 20-750-DENC-1 feedback module PowerFlex 755 and PowerFlex 755T drive products with 20-750-UFB-1 feedback module	1	Configure the Port channel A and channel B for Motor Feedback or Load Feedback

- For PowerFlex 755 drives, Kinetix 5700 drives, and Kinetix 6500 drives, use the dropdown menus to choose the feedback type for the applicable axes.

---

**IMPORTANT** PowerFlex 755 drives require a peripheral device for feedback. You must manually establish the motor or load feedback port and channel assignments on the PowerFlex 755 drive.

---

- Click OK to close the Module Properties dialog box.

---

**IMPORTANT** The Logix Designer application helps prevent the creation of feedback port assignments with incompatible feedback types. For example, you cannot assign the same port for multiple devices. The same port cannot be used for Motor Feedback Device, Load Feedback Device, and Master Feedback Device.

---

## Create a Motion Group

---

**IMPORTANT** All axes must be added to the Motion Group in your project. If you do not group the axes, they remain ungrouped and unavailable for use. You can only have one Motion Group per Logix controller.

---

To create a motion group, follow these instructions.

- In the Controller Organizer, right-click Motion Groups and choose New Motion Group.

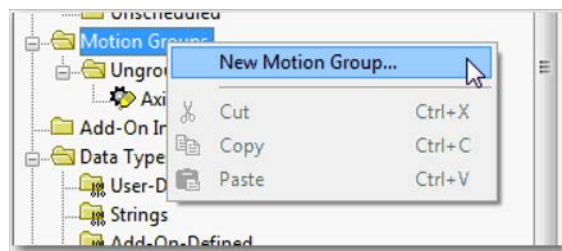

2. Type a name for the motion group.

3. Make any adjustments for your application.
4. Click Create.

## Set the Base Update Period

The Base Update Period is basically the RPI (request packet interval) rate for Ethernet communication between the controller and the motion module, a Unicast connection.

There are two alternate update periods that you can configure when using the Axis Scheduling function. See [Axis Scheduling Configuration on page 63](#) for details.

The Base Update Period determines how often the Motion Task runs. When the Motion Task runs, it interrupts most other tasks regardless of their priority. The Motion Task is the part of the controller that takes care of position and velocity information for the axes.

To set the Base Update Period, follow these steps.

1. Click the Attribute tab in the Motion Group Properties dialog box.

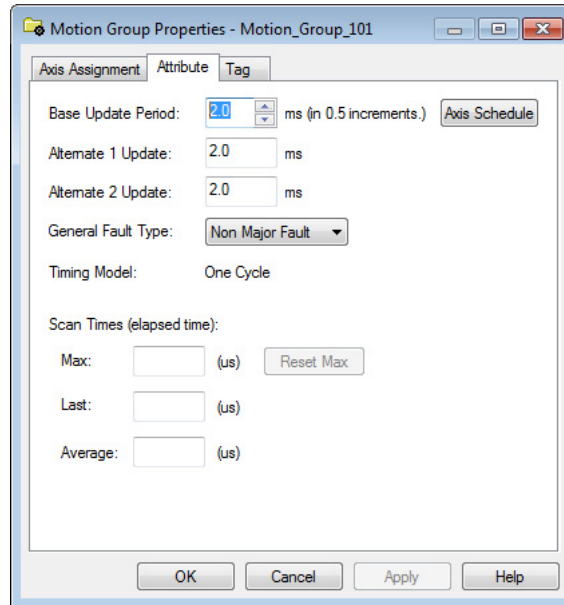

2. Set the Base Update Period.

Drive Type	Minimum Update Period ms
PowerFlex 755	3
PowerFlex 755T	2
PowerFlex 527	4
Other Axis CIP Drives	1



Check the Last Scan time values. Typically, the value is less than 50% of the Base Update Period to reduce group overlap and timing issues in the system.

**Figure 8 - Base Update Period Example**

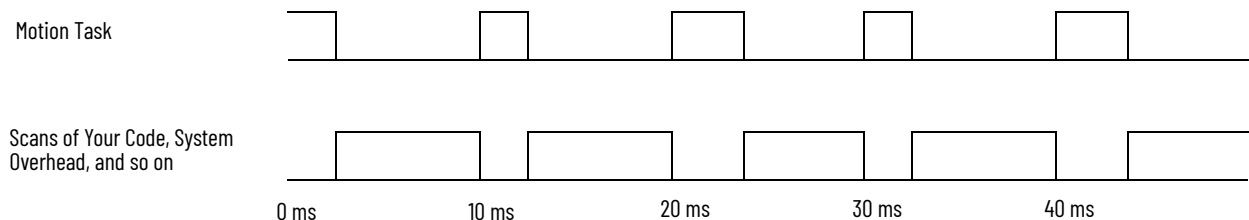

In this example, the Base Update Period = 10 ms. Every 10 ms the controller stops scanning your code and whatever else it is doing and runs the motion



For more information on programming execution, see the Logix 5000 Controllers Tasks, Programs, and Routines Programming Manual, publication [1756-PM005](#).

The Base Update Period is a trade-off between updating the positions of your axes and scanning your code. In general, you do not want the Motion Task to take more than 50% of the overall Logix controller time on average. The more axes that you add to the Motion Group, the more time it takes to run the Motion Task.

For detailed information on the Axis Scheduling function, Axis Assignment tab, and Alternate Update Period Scheduling, see [Axis Scheduling Configuration on page 63](#).

## Associate Axes to the Motion Group

To associate axes to a motion group, follow these steps:

1. Right-click the new motion group and choose Properties.

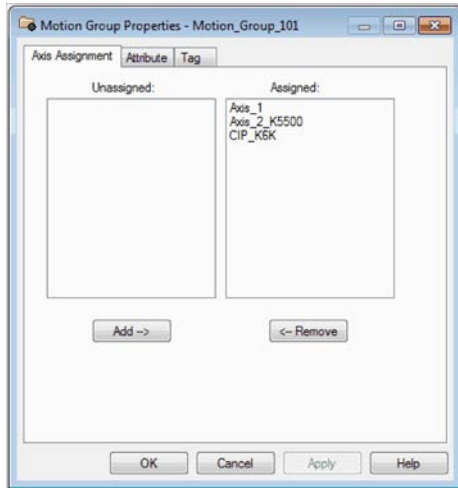

2. Click the Axis Assignment tab and move your axes (created earlier) from Unassigned to Assigned.
3. Click the Attribute tab and edit the default values as appropriate for your application. See Axis Scheduling and Faults for detailed information on the settings available from the Attribute tab.
4. Click OK.

## Configure an Axis and Feedback Type

After you add the drive to your project and create the axes, use the Axis Properties dialog boxes to complete the drive configuration. Notice that the dialog boxes change based on your configuration choices.

[Table 16](#) lists the basic tasks necessary to configure an axis.

**Table 16 - Axis Properties Pages**

Axis Properties Page	Perform These Tasks	Page
General	<ul style="list-style-type: none"> <li>• Assign the axis configuration.</li> <li>• Choose the feedback configuration.</li> <li>• If you have not already done so, you can create and associate an axis to a new Motion Group and associate a drive module to the axis.</li> <li>• Configure Test Mode.</li> </ul>	43
Motor	<ul style="list-style-type: none"> <li>• Specify a motor with the Data Source = Nameplate Datasheet.</li> <li>• Specify a motor with the Data Source = Catalog Number.</li> <li>• Select a motor with the Data Source = Motor NV.</li> <li>• Only the Motor Overload Limit is configurable for iTRAK Sections</li> </ul>	48
Motor Feedback	<ul style="list-style-type: none"> <li>• Select and configure the Motor Feedback Type.</li> </ul>	53
Load Feedback	<ul style="list-style-type: none"> <li>• Select and configure the Load Feedback Type, if applicable.</li> </ul>	55
Master Feedback	<ul style="list-style-type: none"> <li>• Select and configure the Master Feedback Type, if applicable. Master Feedback is only available for Feedback Only axes.</li> </ul>	55
Actions	<ul style="list-style-type: none"> <li>• Configure how an axis responds to fault types.</li> <li>• Modify actions for how an axis responds to fault types.</li> </ul>	56
Exceptions	<ul style="list-style-type: none"> <li>• Define the action to be performed by the drive as a result of an exception condition. Exceptions are conditions that can occur during motion axis operation that could generate faults or alarms.</li> </ul>	57
Scaling	<ul style="list-style-type: none"> <li>• Configure feedback by choosing the load type, by entering the scaling units, and by choosing the Travel mode.</li> <li>• Enter the Input Transmission and Actuator ratio, if applicable.</li> </ul>	119

The parameters that you configure on the General category dialog box result in the presentation of attributes and parameters that are available for the combination of your selections.

**IMPORTANT** All AXIS\_CIP\_DRIVE Axis Properties dialog boxes are dynamic. Optional attributes and dialog boxes that are related to each integrated motion axis that you create come and go based on what combination of axis characteristics you define.

**IMPORTANT** Be sure to associate the drive and axis before when configuring the axis because the drive determines what optional attributes are supported for the axis.

If you have already created an axis and associated it with a drive, the Associated Module and Axis are shown on the General page of the Axis Properties dialog box.

Figure 9 - General Page

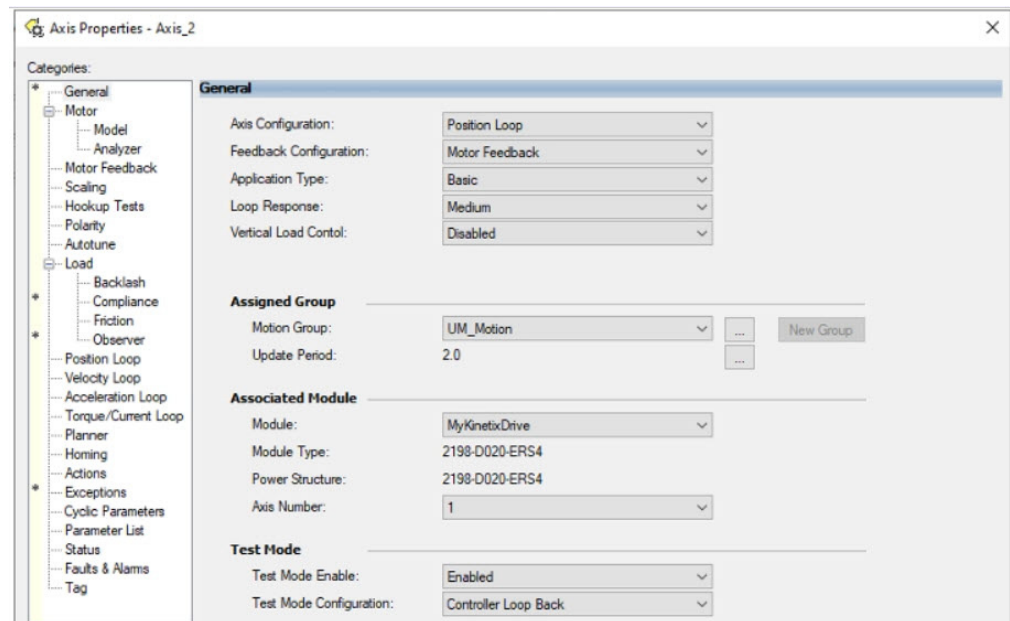

The Axis Number field corresponds to the axes listed on the Associated Axes tab of the Module Properties dialog box. Any feedback port assignments that you made on the Associated Axes page are also mapped to the drive when you associate an axis and a drive.

1. In the Controller Organizer, double-click the Axis that you want to configure.
2. Choose an Axis Configuration type.

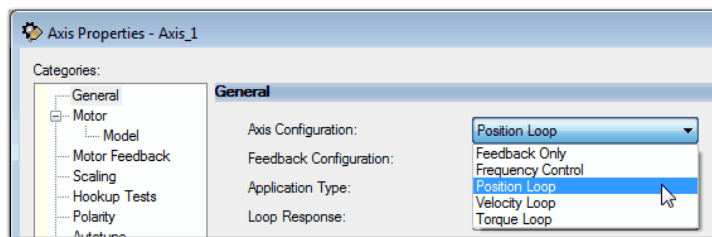

[Table 17](#), [Table 18](#), and [Table 19](#) compare the axis configuration types for Kinetix and PowerFlex drives, and iTRAK systems.

Table 17 - Compare the Axis Configuration Types for the Kinetix Drives

Axis Type	Kinetix 350 Drive	Kinetix 5300 Drive	Kinetix 5500 Drive	Kinetix 5700 Drive Dual-axis Inverter	Kinetix 5700 Drive Single-axis Inverter	Kinetix 5700 DC Bus Supply	Kinetix 5700 Regenerative Power Supply	ArmorKinetix DSM Module	ArmorKinetix DSD Module	Kinetix 6500 Drive
Position Loop (P)	Yes	Yes	Yes	Yes	Yes	No	No	Yes	Yes	Yes
Velocity Loop (V)	Yes	Yes	Yes	Yes	Yes	No	No	Yes	Yes	Yes
Torque Loop (T)	Yes	Yes	Yes	Yes	Yes	No	No	Yes	Yes	Yes
Feedback Only (E)	No	Yes	Yes	Yes	Yes	No	No	Yes	Yes	Yes
Frequency Control (F)	No	Yes	Yes	Yes	Yes	No	No	No	Yes	No
AC/DC Regenerative Converters (G)	No	No	No	No	No	No	Yes	No	No	No
AC/DC Non-Regenerative Converters (N)	No	No	No	No	No	Yes	No	No	No	No

Table 18 - Compare the Axis Configuration Types for the PowerFlex Drives

Axis Type	PowerFlex® 527 Drive	PowerFlex 755 Drive	PowerFlex 755T Drive
Position Loop (P)	Yes	Yes	Yes
Velocity Loop (V)	Yes	Yes	Yes
Torque Loop (T)	No	Yes	Yes
Feedback Only (E)	No	No	No
Frequency Control (F)	Yes	Yes	Yes

Table 19 - Compare the Axis Configuration Types for the iTRAK 5370

Axis Type	iTRAK 5370 Sections	iTRAK 5370 Movers
Position Loop (P)	No	Yes
Velocity Loop (V)	No	No
Torque Loop (T)	No	Yes
Feedback Only (E)	No	No
Frequency Control (F)	No	No
Track Section (X)	Yes	No

- In the Feedback Configuration dropdown menu, choose Motor Feedback.

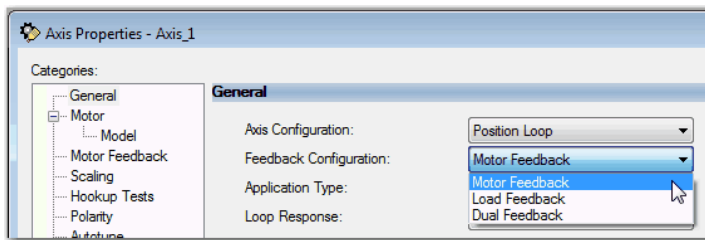

For iTRAK mover and section axes, the Feedback Configuration is always Motor Feedback. For the iTRAK power supply, it is always No Feedback. See [Table 20](#), [Table 21](#), and [Table 22](#) for Kinetix, ArmorKinetix, and PowerFlex drive options, respectively.

Table 20 - Feedback Configuration Types for Kinetix Drives

Feedback Type	Kinetix 350 Drive	Kinetix 5300 Drive	Kinetix 5500 Drive	Kinetix 5700 Single and Dual-axis Inverter Type Drives	Kinetix 5700 DC Bus Supply	Kinetix 5700 Regenerative Power Supply	Kinetix 6500 Drive
Motor Feedback	Position Loop (P), Velocity Loop (V), Torque Loop (T)	Position Loop (P), Velocity Loop (V), Torque Loop (T)	Position Loop (P), Velocity Loop (V), Torque Loop (T)	Position Loop (P), Velocity Loop (V), Torque Loop (T)	—	—	Position Loop (P), Velocity Loop (V), Torque Loop (T)
Load Feedback	—	Position Loop (P), Velocity Loop (V)	—	Position Loop (P), Velocity Loop (V)	—	—	Position Loop (P), Velocity Loop (V), Torque Loop (T)
Dual Feedback	—	Position Loop (P)	—	Position Loop (P)	—	—	Position Loop (P)
Dual Integral	—	—	—	—	—	—	—
Master Feedback	—	Feedback Only (N)	Feedback Only (N)	Feedback Only (N)	—	—	Feedback Only (N)
No Feedback	—	Velocity Loop (V), Frequency Control (F)	Velocity Loop (V), Frequency Control (F)	Frequency Control (F)	AC/DC Non-regenerative Converter Only (N)	AC/DC Regenerative Converter (G)	—

Table 21 - Feedback Configuration Types for ArmorKinetix Modules

Feedback Type	ArmorKinetix DSM	ArmorKinetix DSD
Motor Feedback	Position Loop (P), Velocity Loop (V), Torque Loop (T)	Position Loop (P), Velocity Loop (V), Torque Loop (T)
Load Feedback	—	Position Loop (P), Velocity Loop (V)
Dual Feedback	—	Position Loop (P) <sup>(1)</sup>
Dual Integral	—	—
Master Feedback	Feedback Only (N)	Feedback Only (N)
No Feedback	—	Frequency Control (F)

(1) Connect an ArmorKinetix DSD module to a Kinetix VPL motor by using the ArmorKinetix motor power/feedback cable to use an external auxiliary encoder for dual feedback.

Table 22 - Feedback Configuration Types for PowerFlex Drives

Feedback Type	PowerFlex 527	PowerFlex 755	PowerFlex 755T
Motor Feedback	Position Loop (P), Velocity Loop (V)	Position Loop (P), Velocity Loop (V), Torque Loop (T)	Position Loop (P), Velocity Loop (V), Torque Loop (T)
Load Feedback	—	—	—
Dual Feedback	—	Position Loop (P)	Position Loop (P)
Dual Integral	—	Position Loop (P)	Position Loop (P)
Master Feedback	—	—	—
No Feedback	Frequency Control (F)	Velocity Loop (V), Frequency Control (F)	Velocity Loop (V), Frequency Control (F)

## Complete Axis Configuration Configure Application Type, Loop Response, and Test Mode

Depending on your Axis Configuration and Feedback Type, you have additional options for general axis configuration.

1. Choose the application type, if applicable.

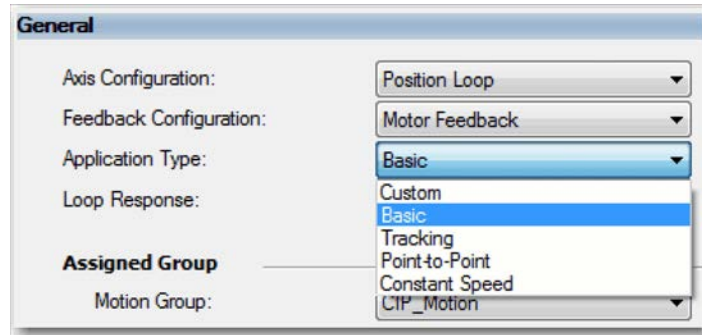

Application Type specifies the type of motion control application and is used to set the Gain Tuning Configuration Bits attribute that establishes the appropriate gain set application. These combinations determine how the calculations are made, which can reduce the need to perform an Autotune or a Manual Tune.

This table provides the gains that are established based on the application type.

**Table 23 - Customize Gains to Tune**

Application Type	Kpi	Kvi	ihold	Kvff	Kaff	torqLPF
Custom <sup>(1)</sup>	—	—	—	—	—	
Basic	No	No	No	Yes	No	Yes
Tracking	No	Yes	No	Yes	Yes	Yes
Point-to-Point	Yes	No	Yes	No	No	Yes
Constant Speed	No	Yes	No	Yes	No	Yes

(1) If you set the type to Custom, you can control the individual gain calculations by changing the bit settings in the Gain Tuning Configuration Bits Attribute.

Include in the table that:

- Kpi = Position Integrator Bandwidth
- Kvi = Velocity Integrator Bandwidth
- iHold = Integrator Hold
- Kvff = Velocity Feedforward
- Kaff = Acceleration Feedforward
- torqLPF = Torque Low Pass Filter

2. Choose a loop response, if applicable.

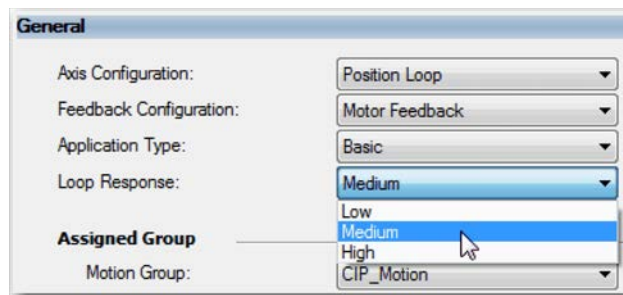

Loop Response settings also impact the calculations that are made and can minimize the need for you to perform an Autotune or a Manual Tune. The loop response impacts the spacing between the position and velocity loops and the proportional and integral gains. This response impacts how aggressively a given profile is tracked.



For information about other application type and loop response settings and attribute calculations, see the specific attribute descriptions in the Integrated Motion on the EtherNet/IP Reference Manual, publication [MOTION-RM003](#).

3. Some drives let you enable or disable a Vertical Load Control function.  
When this feature is Enabled, the drive attempts, whenever possible, to avoid applying Category 0 stop actions in response to Major Fault conditions. The drive may tailor other aspects of its behavior to best handle vertical loads.
4. Enable Axis Test Mode, if applicable.

## Axis Test Mode

Axis Test Mode simulates real-time motion control behavior at the motion axis, motion module, or motion group level, without requiring or using a set of connected hardware. By using Axis Test Mode, you can develop and test the application program without controller network connections to device hardware.

Axis Test Mode is available to enable if the feature is supported by your selected controller.

See [Chapter 9 Axis Test Mode](#) and the Integrated Motion on the EtherNet/IP Reference Manual, publication [MOTION-RM003](#), for details on Axis Test Mode operation.

Axis Test Mode can be enabled in the Axis configuration and/or the motion group configuration. This mode is not available at the module level.

## Complete Axis Configuration for Converter Types

1. Select either a Bus Voltage Control converter or an Active Current Control converter configuration.

Converter Configuration	Definition
Bus Voltage Control	The converter controls the DC bus voltage output of the converter. The output of the DC bus control loop drives an inner Active AC Line current control loop to maintain the commanded DC bus voltage level established by the Bus Voltage setpoint.
Active Current Control	The converter disables DC bus voltage regulation and directly controls the Active AC Line current component based on the Active Current Command.

2. To indicate how the axis transitions from the Stopped state to the Starting state, specify a Converter Startup Method.

Method	Description
Enable Request	The converter stays in the Stopped state until it receives an Enable Request from the controller. After the converter receives the request, it transitions to Starting state and checks for proper AC line synchronization. Once ready for regenerative control, the converter transitions to the Running state with all configured control loops operational.
Enable Input	The converter checks the status of the Enable Input. If it is active, the converter axis transitions from the Stopped state to the Starting state and checks for proper AC line synchronization. Once ready for regenerative control, the converter transitions to the Running state with all configured control loops operational.
Automatic	The converter automatically transitions to Starting state and checks for proper AC line synchronization. Once ready for regenerative control, the converter transitions to the Running state with all configured control loops operational.
Follow Inverter Enabled	The converter monitors the Power Structure Enabled status of all inverters that are connected to the DC bus. When any inverter Power Structure Enabled transitions to Starting state, the converter transitions to Starting state and checks for proper AC line synchronization. Once ready for regenerative control, the converter transitions to the Running state with all configured control loops operational. The Converter Disable Delay value determines the amount of time the converter power structure remains enabled in Running state after the inverter Power Structure Enabled status has transitioned on all inverters connected to the DC Bus.

For Kinetix 5700 Regenerative Bus Supply in Enable Request mode, you must issue an MSO instruction (after AC is applied and CIP\_Axis\_State = STOPPED) to enable voltage regulation on the regenerative bus supply and an MSF instruction to disable voltage regulation.

See the DC Bus Voltage Regulation topic in the [Kinetix 5700 Servo Drives User Manual](#) for important information on configuring regenerative bus supply.

3. Select a Reactive Power Control setting. This setting enables or disables the reactive power control function for the regenerative converter.

When the setting is enabled, the regenerative converter works solely as a reactive power compensation device by injecting reactive power to the grid. The converter does not transfer active power to associated drives on the DC Bus. Instead, the converter's rating capacity is dedicated to reactive power correction to the grid.

## Specify the Motor Data Source

The Motor Data Source is where you tell the axis where the motor configuration values are originating. You can select a motor by catalog number from the Motion Database. You can enter motor data from a nameplate or data sheet, or use the motor data that is contained in the drive or motor nonvolatile memory.

On the Motor dialog box you specify what motor that you want to use and where the data is coming from:

- Specify a motor with the Data Source = Catalog Number. <sup>(1)</sup>
- Specify a motor with the Data Source = Nameplate Datasheet.
- Select a motor with the Data Source = Motor NV (Kinetix Drives) or Drive NV (PowerFlex 755 Drives) <sup>(1)</sup>

For iTRAK systems, the motor data cannot be edited, except for the Motor Overload Limit on iTRAK section axes.

## Choose the Catalog Number as the Motor Data Source

To choose a motor from the Motion Database, follow these steps.

1. If the Axis Properties dialog box is not open, double-click the axis.
2. Go to the Motor dialog box of Axis Properties.

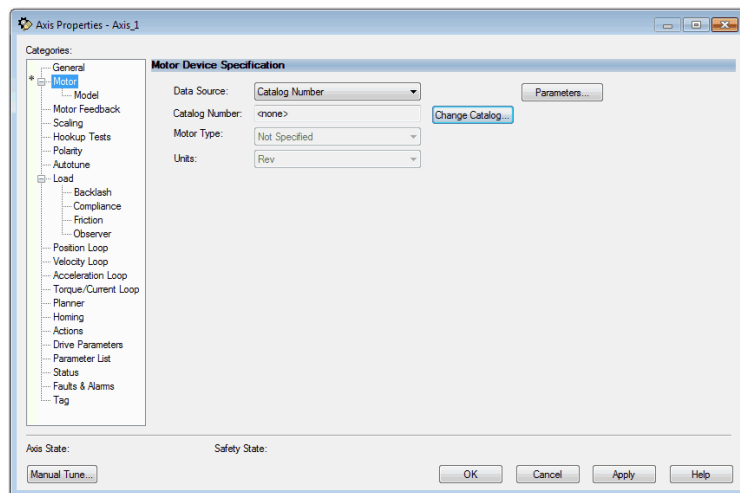

3. From the Data Source dropdown menu, choose Catalog Number.

(1) Not supported for PowerFlex 527 drives.

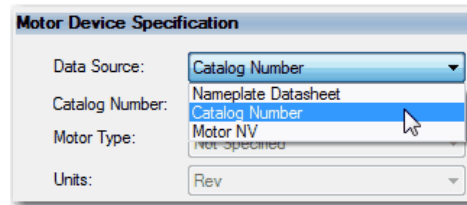

4. Click Change Catalog.
5. Select a motor.

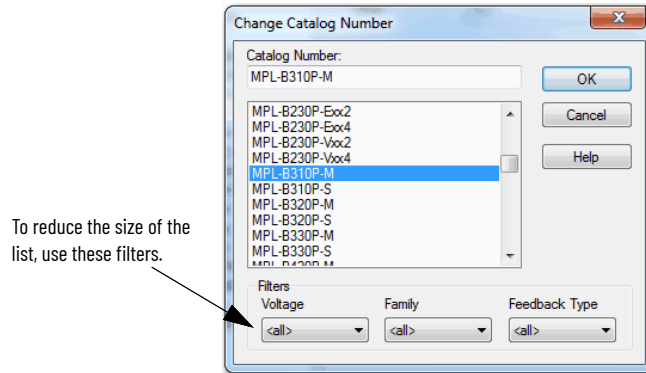

6. The Motor dialog box is now populated with all information that is related to the motor you selected from the Motion Database.

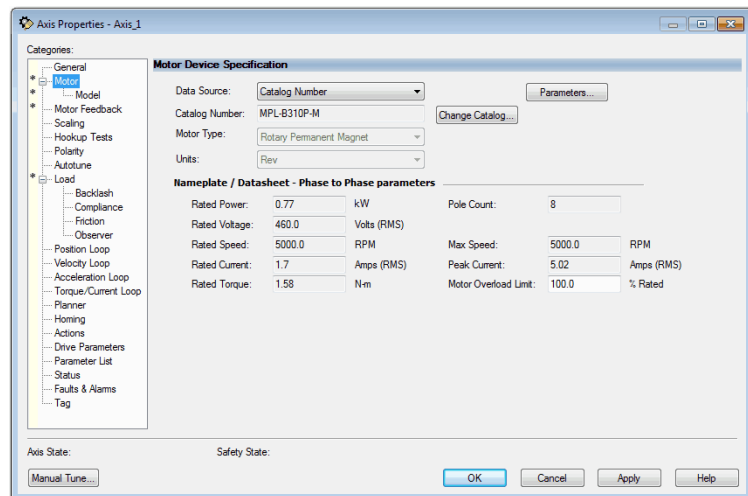

7. Click Apply.



When you use a motor catalog number as the data source, default values are automatically set based on the Application Type and Loop Response settings from the General dialog box.

### Choose Nameplate as the Motor Data Source

The Nameplate option requires you to enter the motor specification information from the motor nameplate and the motor data sheet.

1. On the Motor dialog box of Axis Properties, from the Data Source dropdown menu, choose Nameplate Datasheet.

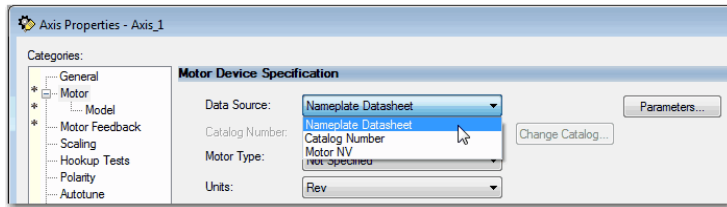

2. Choose a motor type.

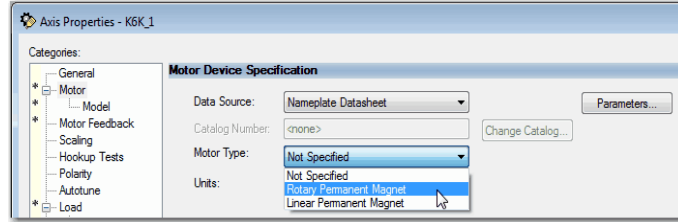

Table 24 shows the motor types that are available.

Table 24 - Motor Types (Kinetix Drives)

Motor Type	Kinetix 350 Drive	Kinetix 5300	Kinetix 5500	Kinetix 5700	ArmorKinetix DSM	ArmorKinetix DSD	Kinetix 6500
Rotary Permanent Magnet	Yes	Yes	Yes	Yes	Yes	No	Yes
Rotary Induction	No	Yes	Yes	Yes	No	Yes	No
Linear Permanent Magnet	No	Yes	Yes	Yes	No	No	Yes
Rotary Interior Permanent Magnet	No	No	No	Yes	No	No	No

Table 25 - Motor Types (PowerFlex Drives)

Motor Type	PowerFlex 755	PowerFlex 755T	PowerFlex 527
Rotary Permanent Magnet	Yes	No	No
Rotary Induction	Yes	Yes	Yes
Linear Permanent Magnet	No	No	No
RotaryInteriorPermanentMagnet	No	No	No

Notice that the motor information fields are initialized to defaults.

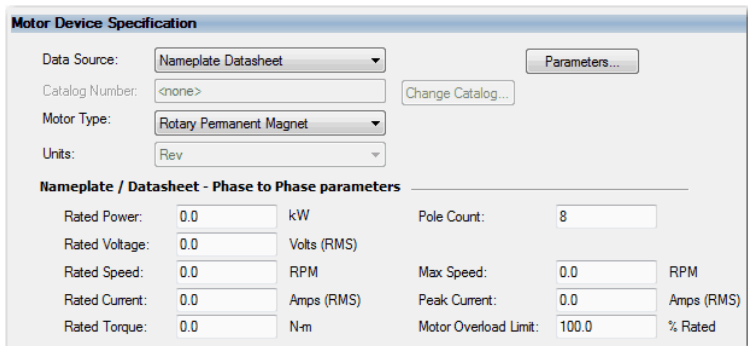

3. Enter the parameter information from the motor Nameplate Datasheet and click Apply.

*Choose Motor NV or Drive NV as the Motor Data Source*

When you choose Motor NV as the data source, the motor attributes are derived from nonvolatile memory of a motor-mounted smart feedback device that is equipped with a serial interface (Motor NV) or from the drive (Drive NV). Only a minimal set of motor and motor feedback (Feedback 1) attributes are required to configure the drive.

1. From the Motor dialog box of Axis Properties, choose Motor NV or Drive NV.

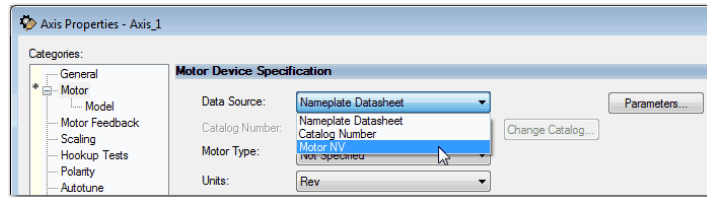

2. Choose the Motor Units that are associated with the motor, either Rev for rotary motor or Meters for linear motor.  
No other motor information is needed.
3. Click Apply.

## Display Motor Model Information

The Motor Model dialog box displays more information that is based on the motor, axis, and feedback configuration types you choose.

The asterisk next to a category means that you have not applied changes.

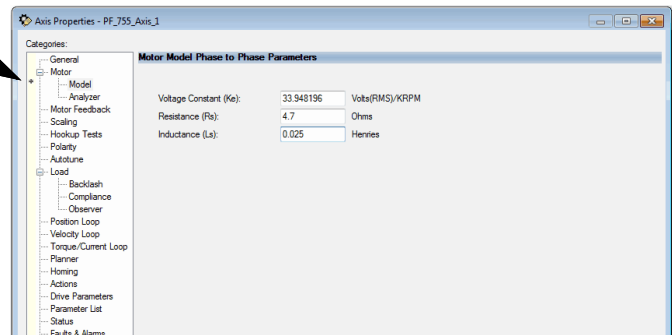

- If the motor data source is Catalog Number, the fields are populated automatically from the database and the fields are read-only.
- If the motor data source is Nameplate Datasheet, you can enter the information.



You can leave the default values, go online, and run a Motor Test to get the proper values from the drive.

See [Hookup Tests on page 122](#).

- If the motor data source is Drive NV, the data comes from the nonvolatile memory of the drive.
- If you select Catalog Number, Motor NV, or Drive NV, the values display as read-only.

## Use Motor Analyzer

For some drives, you can use the Motor Analyzer tool to identify the model for motors that have the data source set to Nameplate Datasheet.

The Motor Analyzer provides the following three tests:

- Dynamic Motor
- Static Motor
- Calculate Model

The tests analyze motor parameters for rotary and linear induction motors and permanent magnet motors. The parameters that appear on the tests are dependent on the motor type you choose.



If the motor you are using is a Permanent Magnet, the Dynamic Motor is the only test that appears.

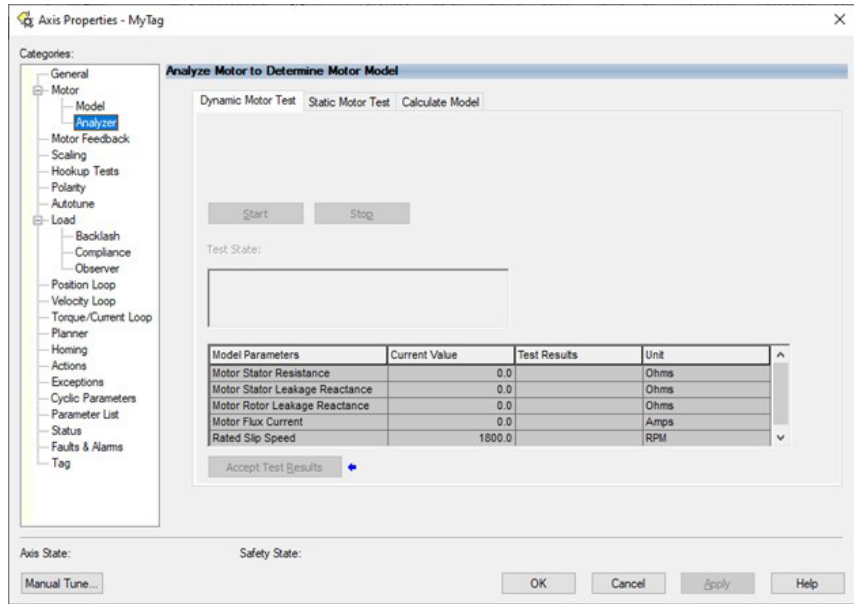

**Table 26 - Motor Analyzer Parameters**

Parameter	Description
Motor Resistance	Specifies the phase-to-phase resistance of a permanent magnet motor.
Motor Inductance	Specifies the phase-to-phase inductance of a permanent magnet motor.
Motor Rotary Voltage Constant	Specifies the voltage, or back-EMF, constant of a rotary permanent-magnet motor in phase-to-phase RMS Volts per KRPM.
Motor Stator Resistance	Specifies the Y circuit, phase-neutral, winding resistance of the stator as shown as R1 in the IEEE motor model.
Motor Stator Leakage Reactance	Specifies the Y circuit, phase-neutral, leakage reactance of the stator winding, at rated frequency, as shown as X1 in the IEEE motor model.
Motor Torque Constant	Specifies the torque constant of a rotary permanent-magnet motor in Newton-meters per RMS amp.
Motor Rotor Leakage Reactance	Specifies the Y circuit, phase-neutral, equivalent stator-referenced leakage inductance of the rotor winding, at rated frequency, as shown as X2 in the IEEE motor model.
Motor Flux Current	Id Current Reference that is required to generate full motor flux. The No Load Motor Rated Current commonly found in Induction Motor data sheets closely approximates the value of the Motor Flux Current. The Kinetix 350 does not support this parameter.
Rated Slip	Rated Slip is the amount of slip at motor rated current (full load) and motor rated frequency.

See the Integrated Motion on the EtherNet/IP Network Reference Manual, publication [MOTION-RM003](#), for complete information on Axis Attributes Motor Feedback.

## Assign Motor Feedback

What appears on the Motor Feedback dialog box is dependent on what you select on the General dialog box for Feedback Configuration.

Axis Configuration Type	Parameters
Feedback Only	Master Feedback
Frequency Control	No Feedback
Position Loop	<ul style="list-style-type: none"> <li>Motor Feedback, one mounted device</li> <li>Dual Feedback, two mounted devices</li> <li>Dual Integral Feedback, two mounted devices</li> </ul>
Velocity Loop	<ul style="list-style-type: none"> <li>Load Feedback</li> <li>Motor Feedback, mounted device</li> </ul>
Torque Loop	<ul style="list-style-type: none"> <li>Motor Feedback, mounted device</li> </ul>

For a Kinetix drive, the Motor Feedback dialog box represents the information for the feedback device that is directly coupled to the motor. This dialog box is available if the feedback configuration that is specified on the General dialog box is anything other than Master Feedback or No Feedback.

Feedback channel attributes that are associated with the Motor Feedback dialog box are designated as Feedback 1.

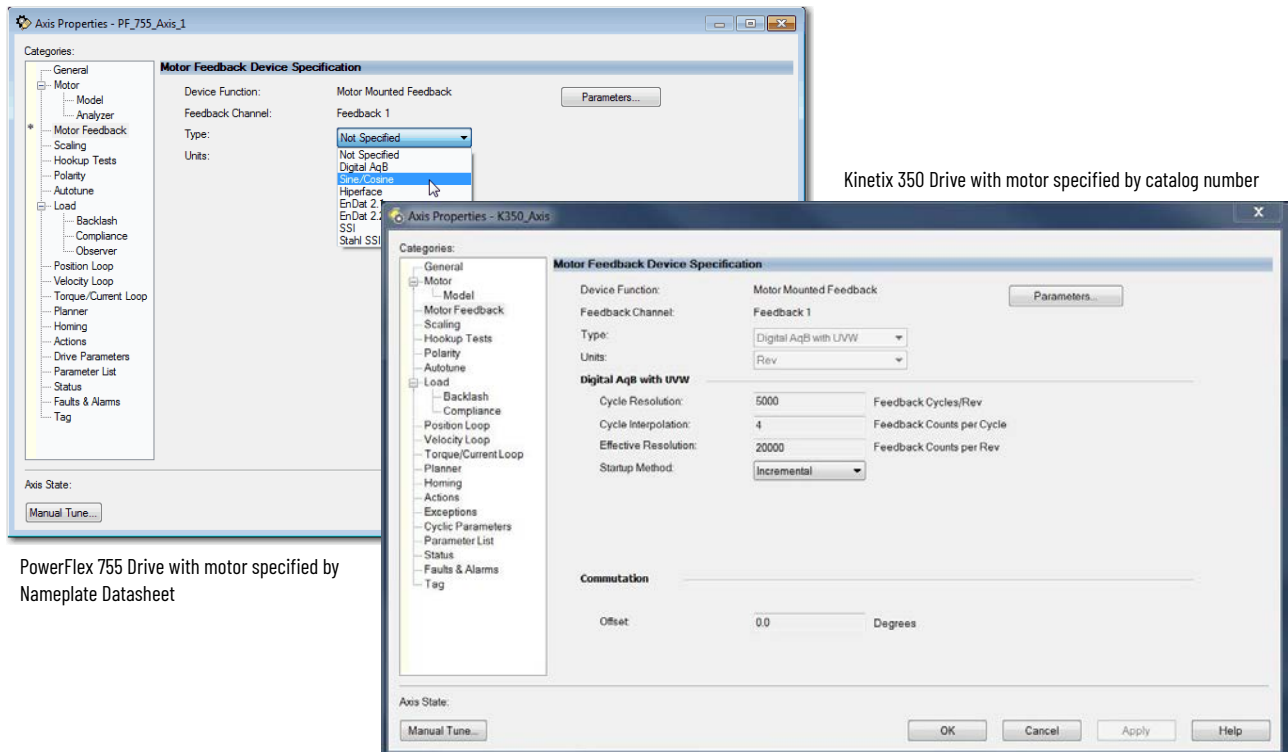

If you chose Catalog Number as the data source for your motor, all information on this dialog box will be entered automatically except for the Startup Method. Otherwise you have to enter the information yourself. Configure the available settings by using the information in [Table 27](#).

Table 27 - Settings

Setting	Description
Type	The type of feedback available depends on the axis and feedback configurations. Some examples include: <ul style="list-style-type: none"> <li>• Not specified</li> <li>• Digital AqB</li> <li>• Sine Cosine</li> <li>• Hiperface DSL</li> <li>• Tamagawa Serial</li> <li>• Stahl SSI</li> <li>• Track Mover<sup>(1)</sup></li> <li>• Track Section<sup>(1)</sup></li> </ul>
Units	<ul style="list-style-type: none"> <li>• Rev for Rotary motors</li> <li>• Meter for Linear motors</li> </ul> If you specified a motor on the Motor page, the value is automatically set.
Cycle Resolution	Enter the cycle resolution for the feedback device.
Cycle Interpolation	Enter the cycle interpolation for the feedback device.
Effective Resolution	Configures or displays the effective resolution of the feedback device. This value is calculated by multiplying the Cycle Resolution with the Cycle Interpolation.
Startup Method	Determines how the device applies the feedback count value during drive startup. Choose from the following: <ul style="list-style-type: none"> <li>• Incremental - The device zeros the feedback count accumulator at power-up.</li> <li>• Absolute - The device initializes the feedback count accumulator at power-up to the absolute feedback position value read from the feedback device. Digital AqB and Sine/ Cosine Feedback Types do not support Absolute startup.</li> </ul>
Turns	For a rotary motor, enter a value for the absolute number of turns for the device to make.
Length	For a linear motor, enter the absolute length of the device.

(1) iTRAK systems only

## Configure Commutation

If a permanent magnet motor is selected from the Motion Database, the Commutation Alignment is set to Controller Offset. However, if a permanent magnet motor is specified from the Nameplate Datasheet, you must specify the Commutation Alignment method. The default is set to Not Aligned.



Commutation fields only appear for feedback device types that support commutation offset, such as Hiperface encoders.

Table 28 - Commutation Alignment Settings

Type	Description
Not Aligned	Not Aligned indicates that the motor is not aligned, and that the Commutation Offset value is not valid. If the Commutation Offset is not valid, the drive cannot use it to determine the commutation angle. Any attempt to enable the drive with an invalid commutation angle results in a Start Inhibit condition.
Controller Offset	Controller Offset applies the Commutation Offset value from the controller to determine the electrical angle of the motor.
Motor Offset	The drive derives the commutation that is offset directly from the motor.
Self-Sense	The drive automatically measures the commutation that is offset when it transitions to the Starting state for the first time after a power cycle. This setting generally applies to a PM motor equipped with a simple incremental-feedback device.

In most cases, the Commutation Alignment is set to Controller Offset and the Commutation test is run during commissioning to determine the Commutation Offset and Polarity.

See the Integrated Motion Reference Manual, publication [MOTION-RM003](#), for more information on axis attributes.



### Effective Resolution Support for PowerFlex 755 Drives:

The AXIS\_CIP\_DRIVE axis properties Motor Feedback category recognizes the support of selectable Effective Resolution as defined in the Add-on Profile (AOP) schema for version 28 controller projects. The Motor Feedback category also lets you select between the choices that are presented. Logix Designer application version 28 modifies the feedback types that define support for the 20-bit fixed Effective Resolution in current PowerFlex 755 schemas. The default selection for Nameplate Datasheet is 20 bit. Version 28 modifies the feedback type to add the new 24-bit fixed Effective Resolution to the schema. You must select the Effective Resolution field to configure for 24 bit. This modification is in addition to the new SSI Digital support that was added for Major Revision 12 of the PowerFlex 755 drives.

## Configure Load Feedback

The Load Feedback category contains the information from the feedback device that is directly coupled to the load-side of a mechanical transmission or actuator.

The Load Feedback category is available if the Feedback Configuration that is specified on the General dialog box is Load or Dual.

Attributes that are associated with the Load Feedback category are designated Feedback 2.

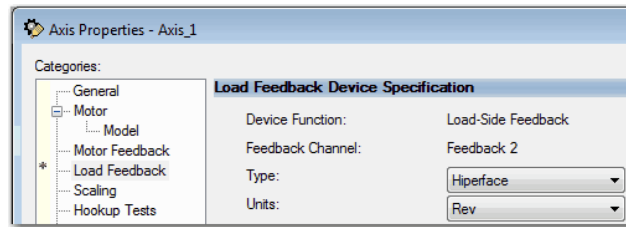

Unlike the Motor Feedback category, you must explicitly enter load feedback-device information on the Load Feedback category, including the Feedback Type. This entry is required because the Load Feedback device is not built into the motor.

**Table 29 - Load Feedback Settings**

Setting	Description
Type	The type of feedback available depends on the axis and feedback configurations. Some examples include: <ul style="list-style-type: none"> <li>• Not specified</li> <li>• Digital AqB</li> <li>• Sine Cosine</li> <li>• Hiperface DSL</li> <li>• Tamagawa Serial</li> <li>• Stahl SSI</li> </ul>
Units	<ul style="list-style-type: none"> <li>• Rev for Rotary motors</li> <li>• Meter for Linear motors</li> </ul>
Cycle Resolution	Enter the cycle resolution for the feedback device.
Cycle Interpolation	Enter the interpolation factor for the feedback device.
Effective Resolution	Configures or displays the effective resolution of the feedback device. This value is calculated by multiplying the Cycle Resolution with the Cycle Interpolation.
Startup Method	Determines how the device applies the feedback count value during drive startup. Choose from the following: <ul style="list-style-type: none"> <li>• Incremental - The device zeros the feedback count accumulator at power-up.</li> <li>• Absolute - The device initializes the feedback count accumulator at power-up to the absolute feedback position value read from the feedback device. Digital AqB and Sine/ Cosine Feedback Types do not support Absolute startup.</li> </ul>
Turns	For a rotary motor, enter a value for the absolute number of turns for the device to make.
Length	For a linear motor, enter the absolute length of the device.

## Configure Master Feedback

The Master Feedback category is available if the Feedback Configuration that is specified in the General category is Master Feedback. The attributes that are associated with the Master Feedback category are associated with Feedback 1. Again, like the Load Feedback category, you must enter all information.

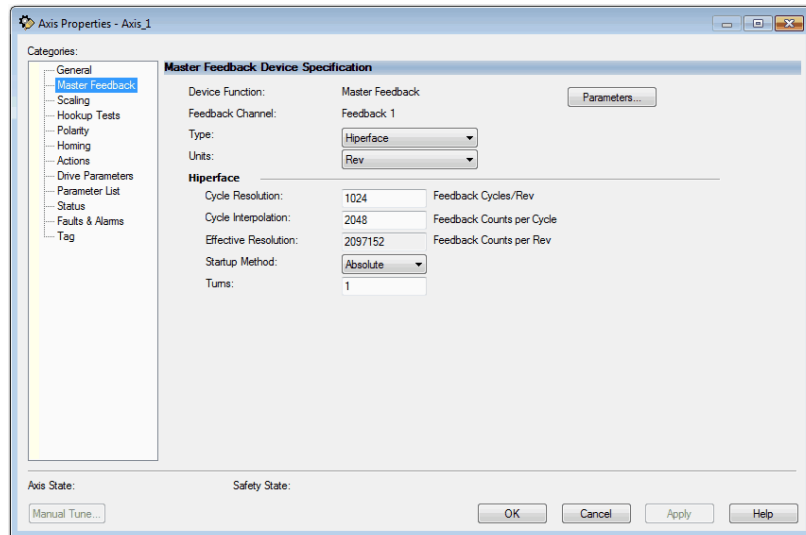

To verify that the motor and feedback device are functioning properly, download to the controller, and continue on to [Hookup Tests on page 122](#).

## Configure Feedback Only Axis Properties

To create your external encoder module and configure feedback-only axis properties if you are using the 842E-CM integrated motion encoder on the EtherNet/IP™ network, see [Example 6: 842E-CM Integrated Motion Encoder with Master Feedback on page 87](#).

## Configure Actions

Configure standard actions to determine how the axis responds to certain faults. The options available for each of the actions depend on the axis configuration and information from the drive's profile. See [Table 30](#).



**ATTENTION:** Changing Action attributes from the Current Decel and Disable setting could endanger personnel, machine, and property if Vertical Load Control is enabled on the General page of the Axis Properties dialog box.

Safety Actions can be configured for the following drives:

- Kinetix 5700 drives with Safe Monitor functionality, catalog numbers 2198-xxxx-ERS4
- PowerFlex 755 drives with a 20-750-S4 integrated safety functions option card installed
- iTRAK 5370

See your drive or safety option module user manual for more information on configuring safety actions for Safe Torque Off (STO) and Safe Stop functions.

Table 30 - Standard Actions

Parameter	Description	Action
Disable (MFS) Stopping Action	Selects the stop action for the motor. The available options depend on the Axis Configuration.	<ul style="list-style-type: none"> <li>• Disable &amp; Coast</li> <li>• Current Decel &amp; Disable</li> <li>• Ramped Decel &amp; Disable</li> <li>• Current Decel &amp; Hold</li> <li>• Ramped Decel &amp; Hold</li> <li>• DC injection brake</li> <li>• AC injection brake</li> </ul>
Connection Loss Stopping Action	Specifies the stopping method applied to the motor when it detects a loss of connection.	<ul style="list-style-type: none"> <li>• Disable &amp; Coast</li> <li>• Current Decel &amp; Disable</li> <li>• Ramped Decel &amp; Disable</li> <li>• Current Decel &amp; Hold</li> <li>• Ramped Decel &amp; Hold</li> <li>• DC injection brake</li> <li>• AC injection brake</li> </ul>
Converter Input Phase Loss Action	Specifies the converter's response to an incoming phase loss while the converter is running.	<ul style="list-style-type: none"> <li>• Continue</li> <li>• Ride thru</li> </ul>
Power Loss Action	Specifies the power loss action for the motor.	<ul style="list-style-type: none"> <li>• Continue</li> <li>• Coast thru</li> <li>• Decel Regen</li> <li>• Ride thru</li> </ul>
Shutdown Action	Specifies the shutdown action of the motor.	<ul style="list-style-type: none"> <li>• Disable</li> <li>• Drop DC Bus</li> </ul>
Motor Overload Action	Specifies the motor overload action for the motor. This field is optional.	<ul style="list-style-type: none"> <li>• None</li> <li>• Current Foldback</li> </ul>
Inverter Overload Action	Specifies the inverter overload action for the motor. This field is optional.	<ul style="list-style-type: none"> <li>• None</li> <li>• Current Foldback</li> </ul>
Drive Overload Action	Specifies the drive overload action for the motor. This field is optional.	<ul style="list-style-type: none"> <li>• None</li> <li>• Current Foldback</li> <li>• Reduce PWM Rate</li> <li>• PWM - Foldback</li> </ul>
AC Line Frequency Change Action	Specifies the converter's action when the rate of change of the AC line frequency exceeds a hard-coded threshold or the configured frequency change threshold.	<ul style="list-style-type: none"> <li>• Continue</li> <li>• Ride thru</li> </ul>
AC Line Sync Loss Action	Specifies the converter's response to an incoming line synchronization loss condition while the converter is running.	<ul style="list-style-type: none"> <li>• Continue</li> <li>• Ride thru</li> </ul>
AC Line Voltage Sag Action	Specifies the converter's response to an incoming AC Line Voltage Sag condition while the device is running.	<ul style="list-style-type: none"> <li>• Continue</li> <li>• Ride thru</li> </ul>
Converter Overload Action	Specifies the device's response to a converter overload condition.	<ul style="list-style-type: none"> <li>• None</li> <li>• Current Foldback</li> </ul>

For details on Actions, see the [MOTION-RM003](#).

## Configure Exceptions

Drives with Motion Only connections let you define the action that is performed by the drive as a result of an exception condition. Exceptions are conditions that can occur during motion axis operation that could generate faults or alarms. The associated drive of the axis controls which actions are available for each Exception. When a fault or alarm occurs, the corresponding fault or alarm axis attributes are set.

The controller continuously evaluates the status of all exceptions. When multiple exceptions are active, the controller applies the most severe Exception Action. If an exception is active and another exception with a more severe Exception Action becomes active, the controller changes the Exception Action to the more severe action. Exception Action severities are listed after this in increasing order of severity.

For more information on exceptions, see [Configure the Exception Actions for AXIS\\_CIP\\_DRIVE on page 188](#).

Table 31 - Exception Actions

Exception Action	Definition
Ignore	The controller completely ignores the exception condition. For some exceptions that are fundamental to the operation of the planner, Ignore is not an available option.
Alarm	The controller sets the associated bit in the Motion Alarm Status word, but does not otherwise affect axis behavior. If the exception is so fundamental to the drive, Alarm is not an available option. When an exception action is set to Alarm, the Alarm goes away by itself when the exceptional condition has cleared.
Fault Status Only	Fault Status Only instructs the controller to set the associated bit in the Motion Fault Status word, but does not otherwise affect axis behavior. An explicit Fault Reset is required to clear the fault once the exceptional condition has cleared. Like Ignore and Alarm, if the exception is so fundamental to the operation of the drive, Fault Status Only is not an available option.
Stop Planner <sup>(1)</sup>	The controller sets the associated bit in the Motion Fault Status word and instructs the Motion Planner to perform a controlled stop of all planned motion at the configured maximum deceleration rate. An explicit Fault Reset is required to clear the fault once the exceptional condition has cleared. If the exception is so fundamental to the drive, Stop Planner is not an available option.
Disable	When the exception occurs, the associated bit in the Fault Status word is set and the axis comes to a stop by using the stopping action that is defined by the drive for the particular exception that occurred. There is no controller-based configuration to specify what the stopping action is, the stopping action is device-dependent.
Shutdown	When the exception occurs, the drive brings the motor to a stop by using the stopping action that is defined by the drive and the power structure is disabled. An explicit Shutdown Reset is required to restore the drive to operation.

(1) Stop planner is not applicable to torque mode

For details on Exception Actions, see the [MOTION-RM003](#).

## Axis Scheduling

This chapter describes how to configure the Axis Scheduling feature that is in the Motion Group properties dialog box.

Axis Scheduling provides a way for you to configure drives to run at different update rates. Axis Scheduling can improve the performance of your controllers. You can use Axis Scheduling with integrated motion drives and virtual axes. By using Axis Scheduling, you can optimize your controller, network, and drive performance. For smaller controller applications, such as CompactLogix™, you can expect to see a significant improvement in system performance.

Many applications have motion drives with different performance requirements. At the simplest level, motion drives can be assigned into a 'fast' and 'slow' update rate groupings.

- The 'fast' group typically includes high-speed coordinated process positioning drives with aggressive PCAM or interpolation profiles and auxiliary functions like registration position/velocity phase correction.
- The 'slow' group typically includes non-coordinated motion drives used for automatic machine reconfiguration, non-coordinated point-to-point motion process drives, or coordinated drives with less aggressive PCAM or gearing functions.

Axis Scheduling is compatible with these products:

- ControlLogix® 5580 controllers
- GuardLogix® 5580 controllers
- CompactLogix 5380 controllers
- Compact GuardLogix 5380 controllers
- ControlLogix 5570 controllers
- GuardLogix 5570 controllers
- CompactLogix 5370 controllers
- Compact GuardLogix 5370 controllers
- All Integrated Motion EtherNet/IP™ drives, for example, Kinetix®, ArmorKinetix®, and PowerFlex® drives

### About Axis Scheduling

Axis Scheduling can improve ControlLogix and CompactLogix EtherNet/IP Integrated Architecture® Motion system performance by reducing average Logix controller and EtherNet/IP network utilization. Axis Scheduling supports three separate controller/network motion drive update rates per controller, one rate for high-performance drives, and two additional rates for lower performance drives.

For example, suppose that you have a robot that removes product from a conveyor belt. There are three precision axes on the robot and four general-purpose axes on the conveyor belt. If you configure the controller to run all seven axes at 2 ms to control the precision axes, this setting takes the network utilization of your controller too high. In the past, one option would have been to run all seven axes at 8 ms, but this setting is not fast or precise enough for the robot axes. So you have had to add a second controller and Ethernet module to get the performance you needed. Axis Scheduling lets you configure the axes at different rates that are based on the needs of the application, which balances the motion performance and network utilization of your controller.

With Axis Scheduling, you can configure the axes on the robot to run at a faster base-update rate (2 ms) than the rate of the conveyor (8 ms).

With the ability to configure three update periods, the four conveyor axes can run as one channel, which appears to the controller as one drive. The axes are updated round-robin style; every 2 ms, three of the robot axes and one of the conveyor axes are updated.

During the next update, three robot axes are updated and then the next conveyor axis is updated; eventually all conveyor axes are updated and the process starts again. The controller updates four axes every update period. The controller can handle the load of four axes easier than a load of seven axes. This capability improves the performance of the controller.

## Timing Model

The general timing model for the integrated motion on the EtherNet/IP network I/O connection data exchange is described in this section. The Timing Model field on the Attribute tab of the Motion Group Properties dialog box is shown as One Cycle or Two Cycle. See [Figure 10](#) for an example.

Figure 10 - Timing Model Attribute Examples

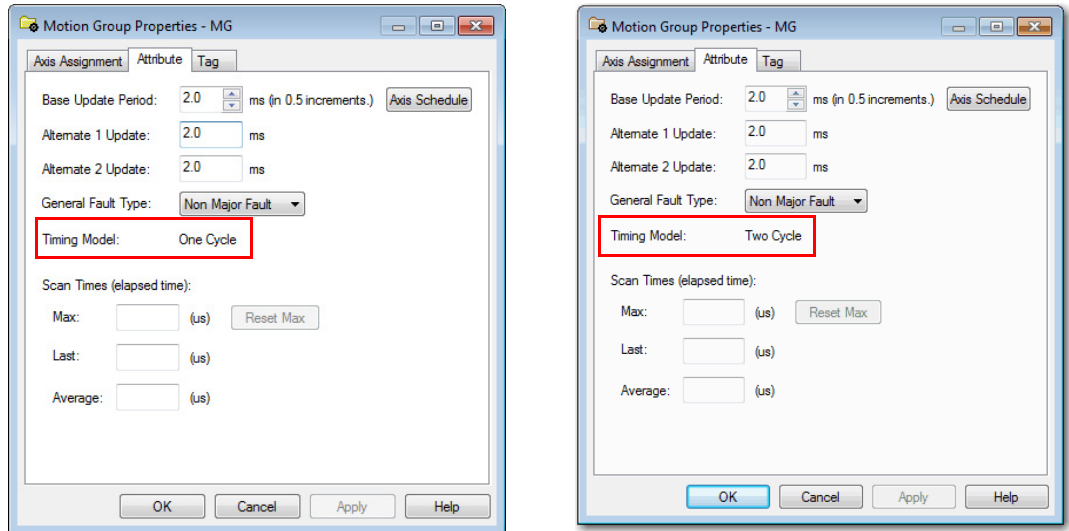

Table 32 - CIP Motion Timing Model

Controller	Timing Model
1756-L7 or 1769-L and earlier	One cycle
1756-L8 and 5069 and later	Two cycle

## One Cycle Timing

The Controller Update Period paces data exchange between the device and the controller with one Device-to-Controller data packet that is sent for every Controller-to-Device data packet received. The Controller-to-Device Connection packets are sent periodically according to the configured Controller Update Period. The Device Update Period, which is the update period at which the device performs its control calculations, is typically much faster than the Controller Update Period. The basic integrated motion on the EtherNet/IP network 1-cycle timing model is shown in [Figure 11](#).

Figure 11 - Integrated Motion on the EtherNet/IP Network One Cycle Timing Model

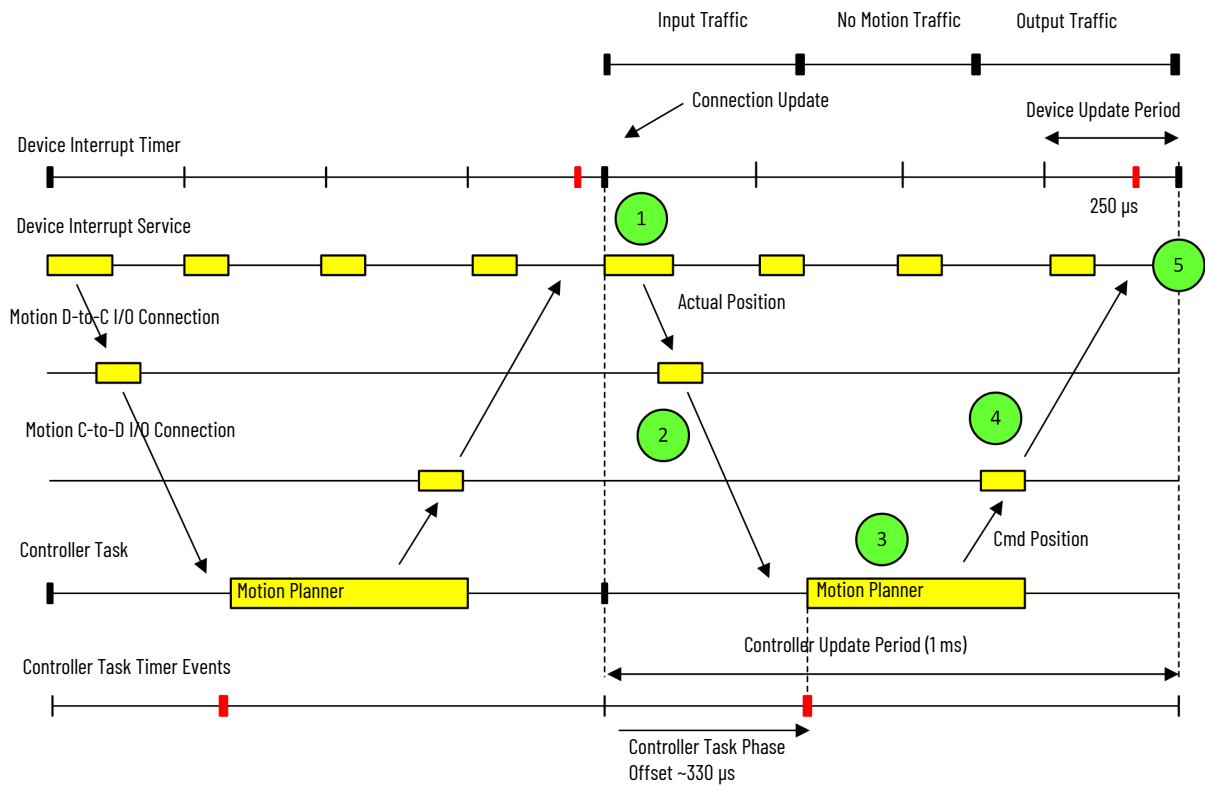

## Two Cycle Timing

The Two Cycle Timing Model that is shown in [Figure 12](#) begins with the device transmitting the D-to-C connection packet to the controller at the beginning of the update cycle. In this case, the Controller Task does not start until half way through the update cycle. This start point allows more time for the D-to-C connection packet to reach the controller before the Motion Planner task runs. Unlike the One Cycle Timing Model, the C-to-D connection packet is not transmitted back to the device until the next time the Motion Planner task runs. This delay again allows more time for the C-to-D connection packet to reach the device. It takes two connection cycles to complete the I/O data transaction with the device.

Figure 12 - Integrated Motion on the EtherNet/IP Network Two Cycle Timing Model

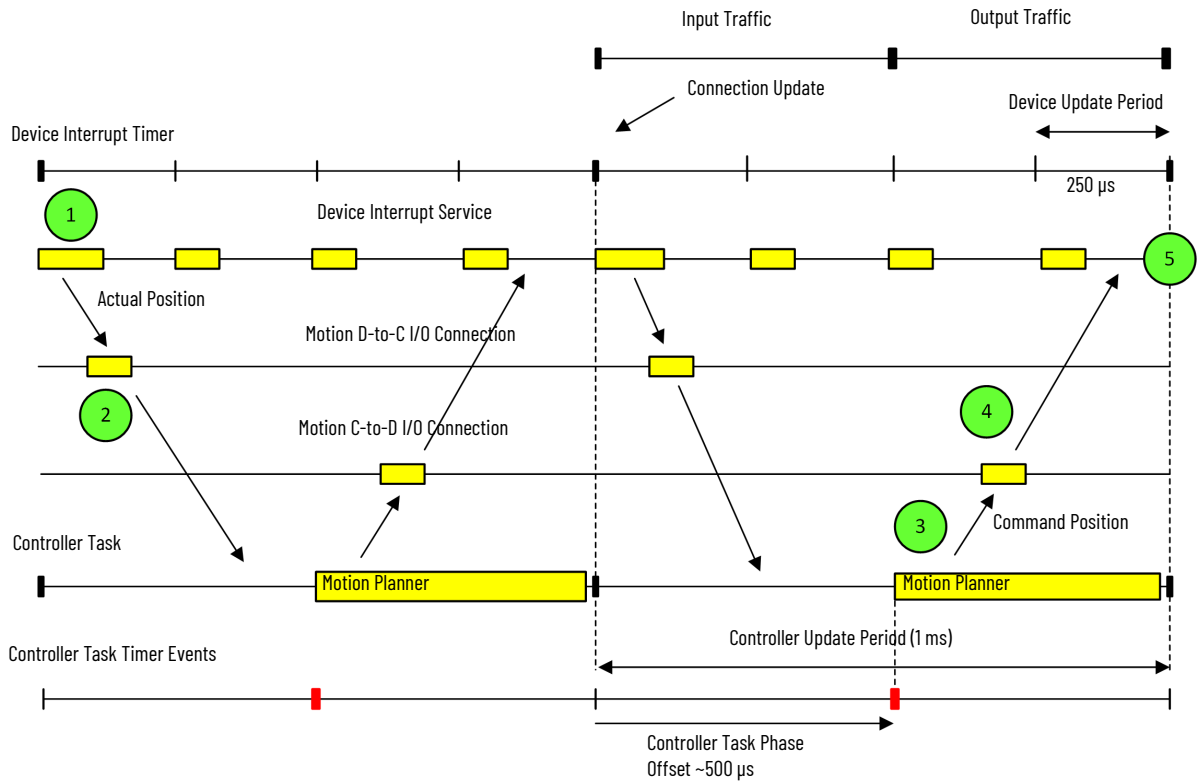

## Axis Scheduling Configuration

In the Studio 5000 Logix Designer application, you use the Axis Schedule Panel, accessible from the Attribute tab of the Motion Group Properties dialog box, to configure the update periods. The Axis Schedule Panel provides a Base Update Period and two alternatives. Information such as Estimated Utilization and Actual Utilization appear on this panel.

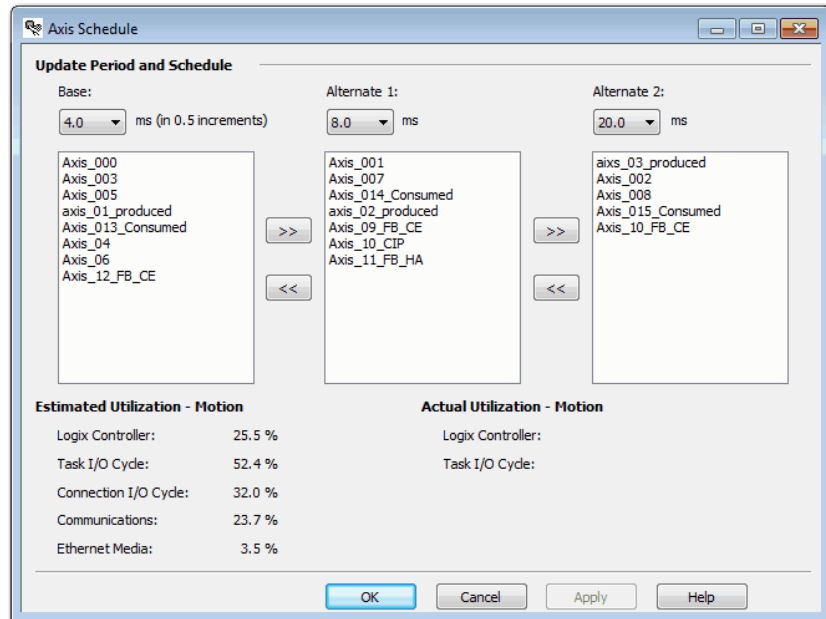

The alternative rates for lower performance drives provide a way for multiple drives to be 'multiplexed' through one drive update channel. Axis Scheduling allows multiple drives to be updated by using the same amount of controller and network capacity as used in updating one non-multiplexed drive.

For more information on how to configure a motion group for Kinetix or PowerFlex drives, see [Create a Motion Group on page 39](#).

## Configure the Update Periods

Follow these steps to configure the update periods:



To change all update rates to the same value, refer to the example on [page 67](#).

1. Double-click the Motion Group.

The Motion Group Properties dialog box appears.

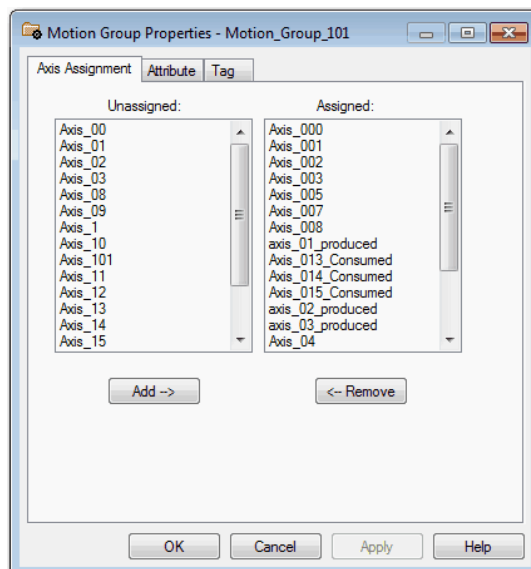

2. Assign axes to the group if necessary.

3. Click Apply.
4. Go to the Attribute tab.
5. Choose a Base Update Period.

In this example, the Base Update Period is 4.0 ms and the Alternate 1 and 2 Update Periods are 8 ms and 20 ms. The base period acts as the anchor value for the axis scheduling feature.

The Alternate Update Periods are multiples of the base. You can edit the Base Update Period when the controller is offline and is read-only when the controller is online. The alternate rates on the Attribute tab are read-only.

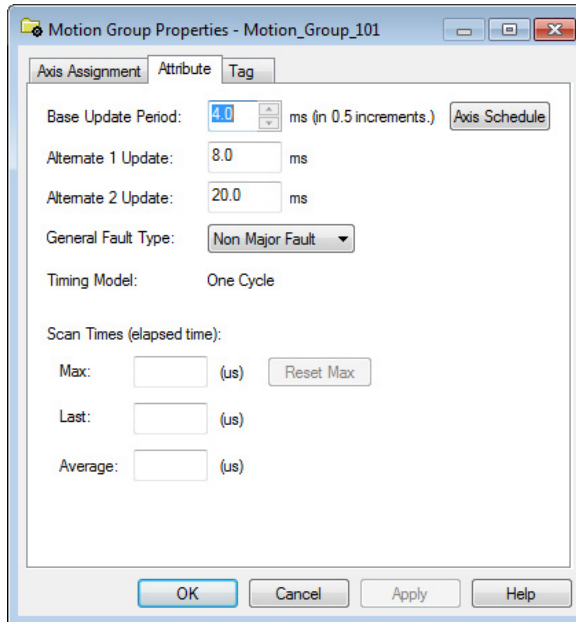

6. To go to the Axis Schedule Panel, click the Axis Schedule.

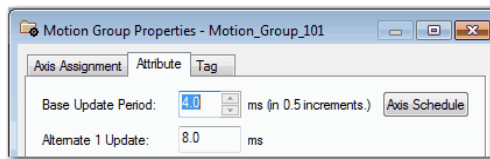

The Axis Schedule Panel appears.

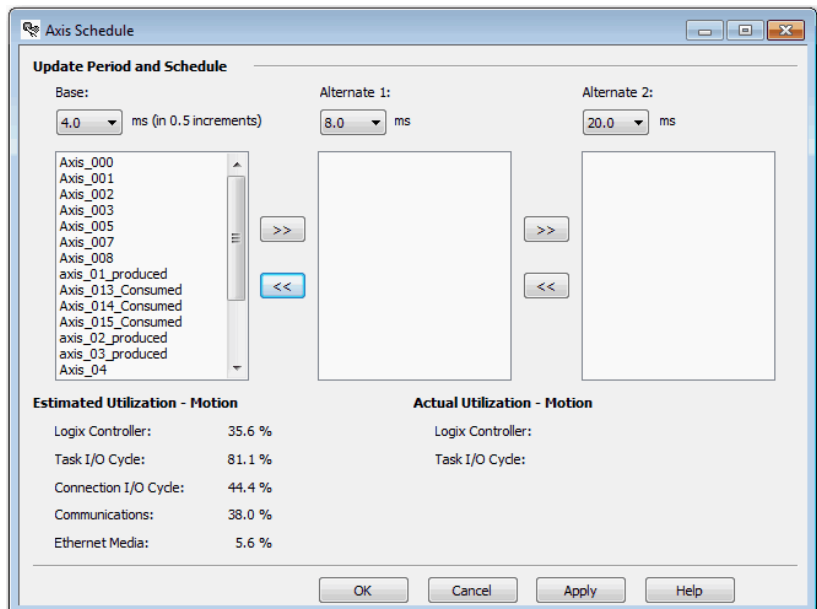

The axes that you assigned in the Axis Assignment tab appear in the Base column.

7. To assign the axes to the Alternate Update Periods, use the positioning arrows. The axes appear in the Alternate columns.

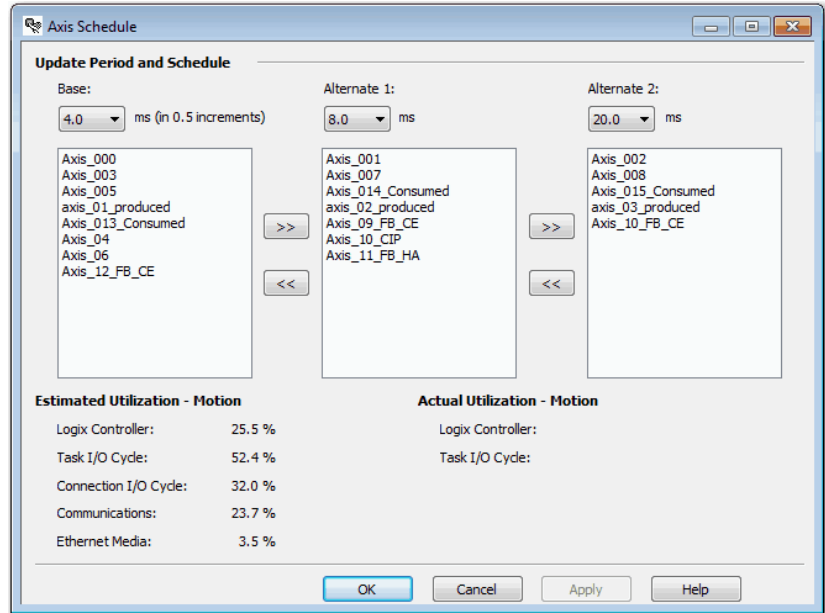

8. Choose the Alternate 1 Update Period.

The multipliers range from 2...32, so if the base update rate is 2.0, the values in the alternate rates are 4, 6, 8, 10, 12...32. If the base update rate is 3.0, the values are 6, 9, 12, 15, and so on.

If you change the Base rate to a value that the Alternate rate value is not a multiple of, a warning flag appears next to the Alternate rate.

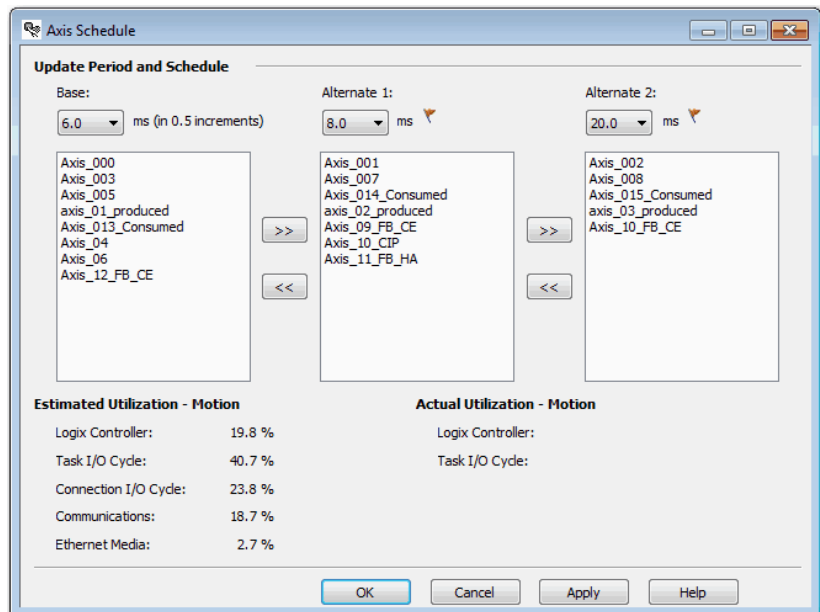

Once an alternate rate is set on the Axis Schedule Panel, the Base Update Period for the group on the Attribute tab becomes disabled. You can still set the base update rate on the Axis Schedule Panel.

A warning appears and the value is set to either 0.5 or 32 if you enter a value outside of the acceptable range.

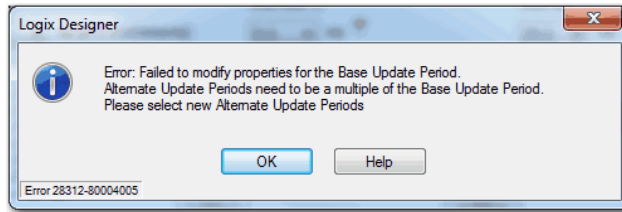

If the Base Update Period is too small, the controller does not have time to execute non-motion related Ladder Logic.

As a result, the configuration sets the lower limit on the Base Update Period that is based on the number of axes in the group.

You can use Integrated Architecture Builder (IAB) to determine the performance information that is based on your system configuration.

Too many axes per base rate can indicate one of the following:

- There is not enough time for the motion task to execute, which results in a motion task overlap error.
- There are high-application program scan times, which affect all logic: program logic that supports motion applications and general program logic.

9. Choose the Alternate 2 update period.

If the base update rate is changed to a value that invalidates the alternate update rates, a warning tool tip appears.

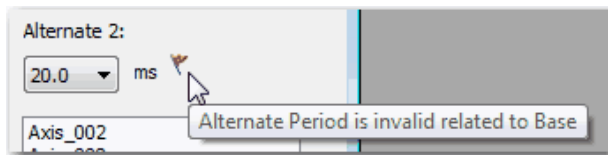

If you click OK or Apply, a warning box appears that tells you that you must select valid alternate update rates before you apply any changes.

10. Update the periods as required.

11. Click Apply.

The Alternate update rates appear on the Attribute tab.

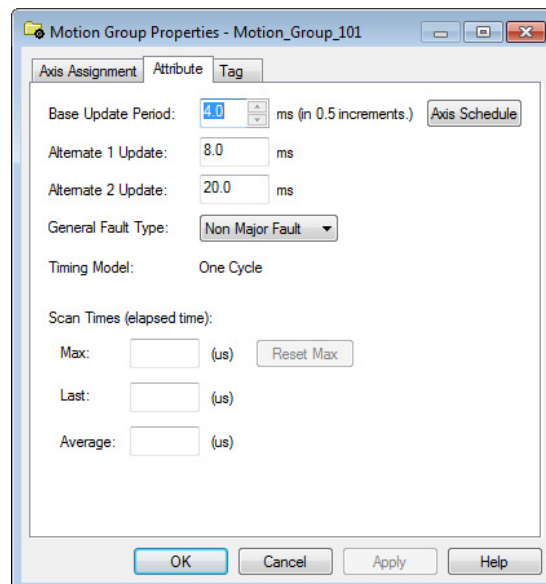

The following example shows what happens on the various dialog boxes when all update rates are changed to the same value.

1. To change all rates to the same value, for example 4 ms, go to the Axis Schedule Panel.

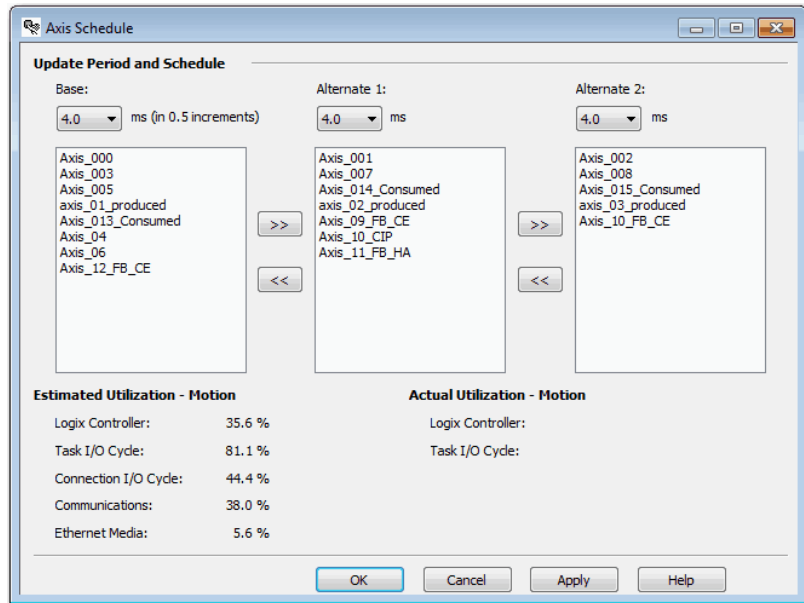

The Base Update Period on the Attribute tab becomes active.

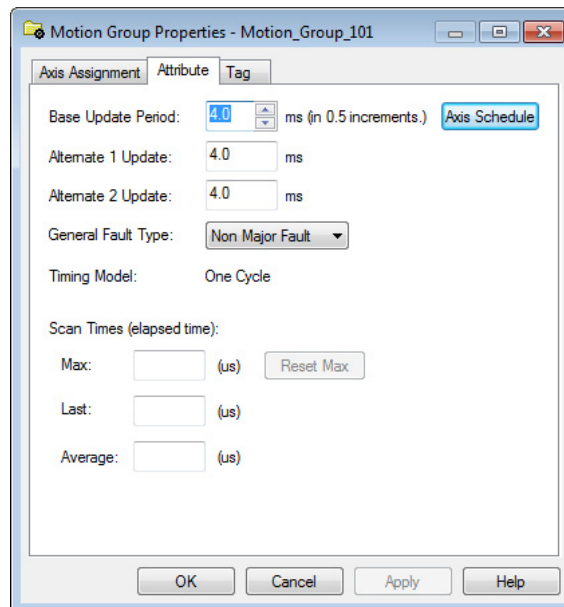

After you have made all update periods in the Axis Schedule Panel, the update period values are the same and the Base Update Period is now active. The Alternate Update Periods are always read-only.

2. Change the Base Update Period.

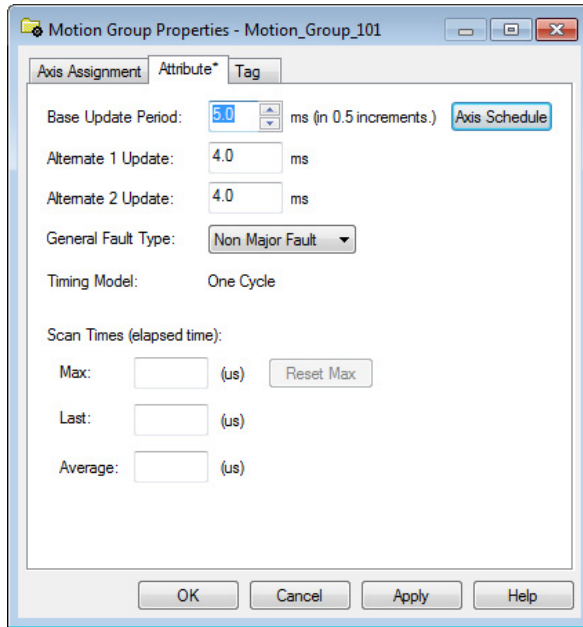

After you click Apply (or OK), the values in the alternate fields change to match the base.

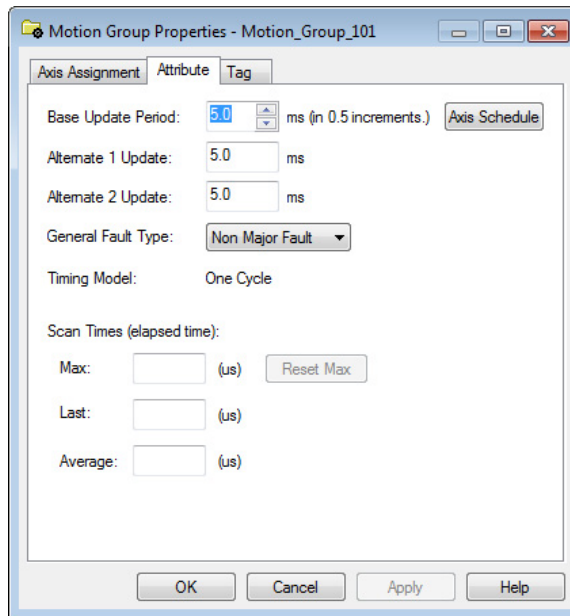

The values are also changed in the Axis Schedule Panel.

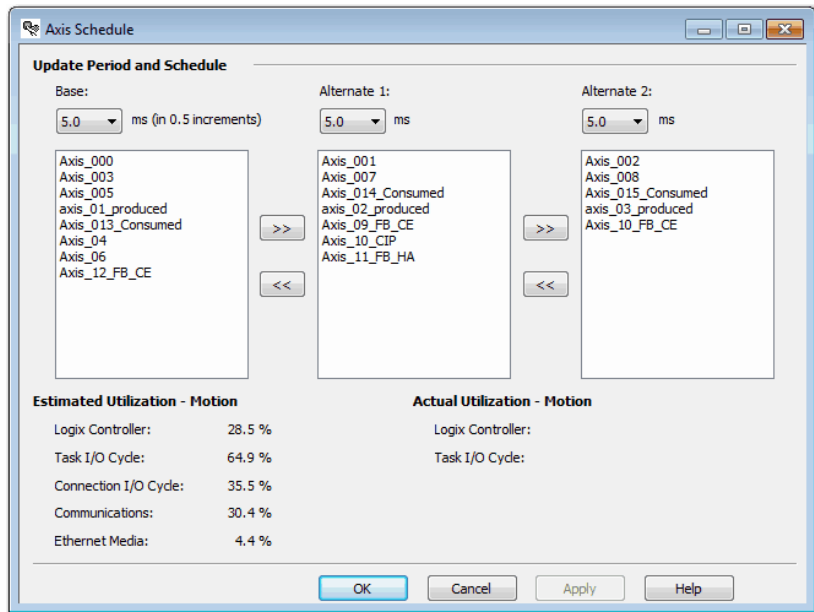

## Motion Utilization

The following values are updated in real time as you change your configuration. You can see how the utilization metrics are responding to your configuration changes and you can modify your configuration.

Estimated Utilization - Motion		Actual Utilization - Motion	
Logix Controller:	66.1 %	Logix Controller:	
Task I/O Cycle:	135.4 %	Task I/O Cycle:	
Connection I/O Cycle:	77.2 %		
Communications:	62.7 %		
Ethernet Media:	9.2 %		

- The yellow warning icons indicate that the value is at the borderline of the controller capabilities.
- The red X next to the Task I/O Cycle and Connection I/O Cycle warnings indicates that the value has reached beyond what the motion task cycle can handle.

If you are reaching utilization limits and you only have the Base Update Period that is assigned to axes, start to assign axes to the Alternate Update Periods.

**Table 33 - Utilization Parameter Descriptions**

Parameter	Description
Estimated Utilization - Motion	Estimated utilization assumes basic default configuration with no active motion planner activity, no transmission statistics, and no cyclic read or write. The estimated percent of time the controller spends on motion while online.
Logix Controller	The estimated percentage of time of the Logix controller that a motion task consumes. If this value exceeds 50%, a warning icon appears. If this value exceeds 80%, an error icon appears.
Task I/O Cycle	The estimated percentage of time available in the update cycle Motion Task to process input, run motion planner, and send output to motion devices. If this value exceeds 100%, a warning icon appears. If this value exceeds (200 connection I/O cycle Cycle)%, an error icon appears.
Connection I/O Cycle	The estimated percentage of time available in the update cycle for input and output data transmission over the motion connection. If this value exceeds 80%, a warning icon appears. If the value exceeds 100%, an error icon appears.
Communications	Shows the estimated percentage of time of the communications controller that the motion connection packets consume. If this value exceeds 50%, a warning icon appears. If this value exceeds 100%, an error icon appears.

**Table 33 - Utilization Parameter Descriptions (Continued)**

<b>Parameter</b>	<b>Description</b>
Ethernet Media	Shows the estimated percentage of Ethernet media bandwidth that motion-connection packet traffic uses. If the value exceeds 50%, a warning icon appears. If the values exceed 100%, an error icon appears.
Actual Utilization - Motion	Actual utilization is based on measurements that are made by the Logix controller. Actual utilization values can be substantially higher than estimated utilization values depending on factors such as active motion planner activity, transmission statistics, and cyclic read or write data.
Logix Controller	Shows the actual percentage of time of the Logix controller that the motion task consumes.
Task I/O Cycle	Shows the actual percentage of time available in the update cycle for motion task to process input, run motion planner, and send output to motion devices.

## Configuration Examples for a Kinetix Drive

This chapter provides typical axis-configuration examples when using Kinetix® 350, Kinetix 5500, Kinetix 6500, and Kinetix 5700 drives. The differences between the Kinetix drives are noted where applicable.

Kinetix 5700 drive configurations are similar to the examples in this chapter. For more examples of how to configure the Kinetix 5700 drive, see the Kinetix 5700 Servo Drives User Manual, publication [2198-UM002](#).

### Example 1: Position Loop with Motor Feedback Only

This example assumes that you have:

- Added your drive to your project.
- Created an associated axis for motor feedback.
- Added the axis to a motion group.

In this example, you create an `AXIS_CIP_DRIVE` and a Kinetix 6500 drive, which includes the control module and a power structure. You then connect the motor feedback cable to the Motor Feedback port of the Kinetix 6500 drive.

1. Open the Axis Properties.
2. From the Axis Configuration dropdown menu, choose Position Loop.
3. From the Feedback Configuration dropdown menu, choose Motor Feedback.

The axis and feedback configurations determine the control mode.

For more information on the control modes, see the Integrated Motion on the EtherNet/IP network Reference Manual, publication [MOTION-RM003](#).

Figure 13 - Example 1: General Dialog Box, Position Loop with Motor Feedback Only

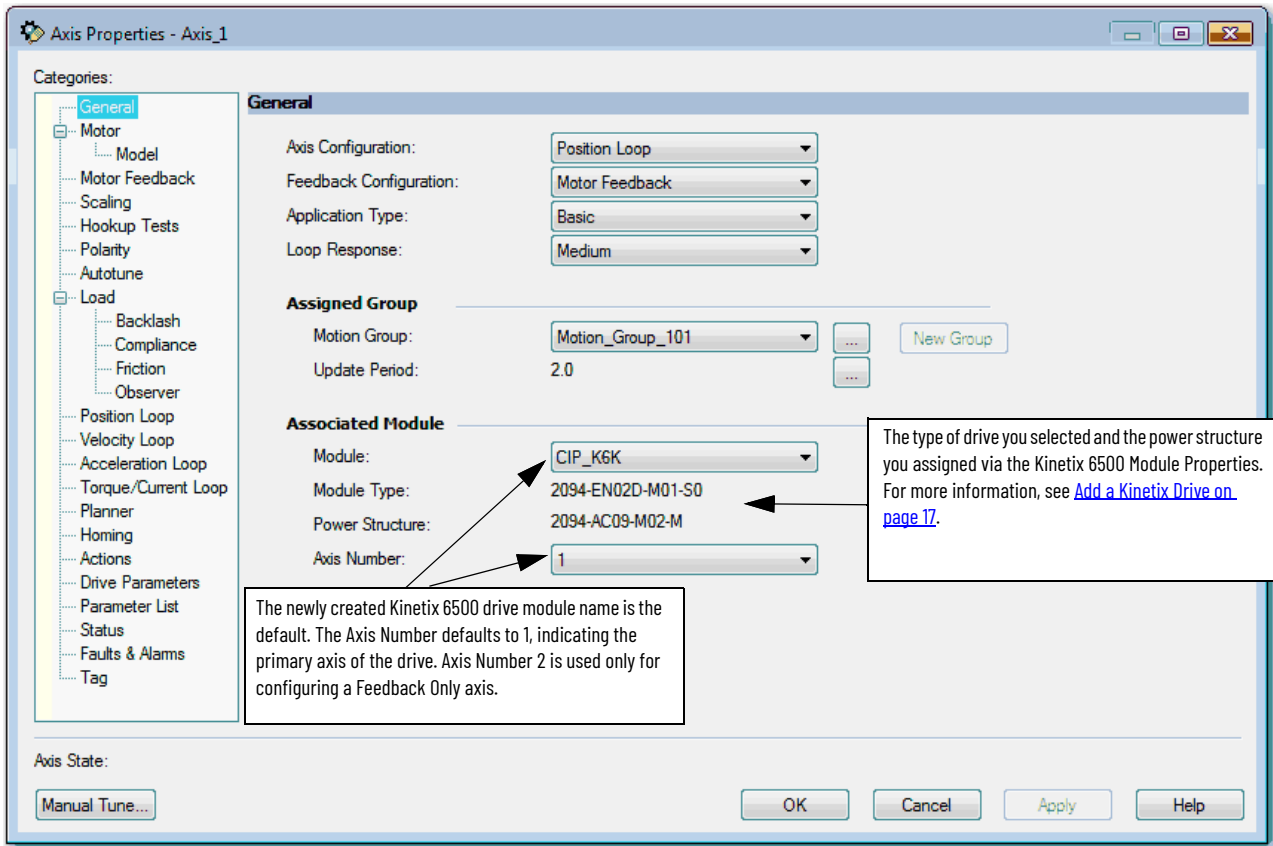

After you have configured the axis and you change the Axis Configuration type or the Axis Number, some of the configuration information is set to default values. This change can cause some previously entered data to be reset back to its default setting.

When you select the Position Loop with Motor Feedback, the Motor and Motor Feedback dialog boxes become available.

4. Choose Catalog Number as the Motor Data Source.
5. Click Change Catalog and choose your motor.

In this case, a MPL-B310P-M motor was chosen.

Figure 14 - Example 1: Position Loop with Motor Feedback Only, Motor Dialog Box

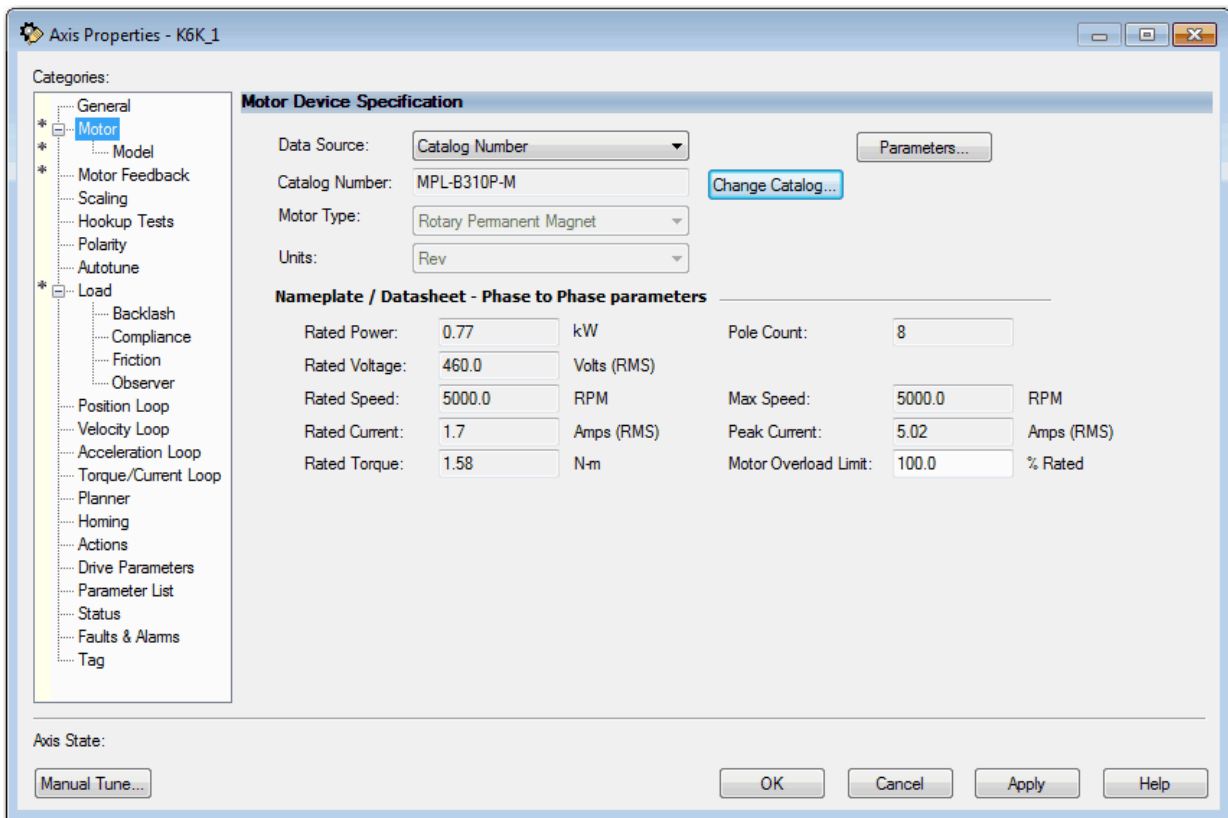

- Click Change Catalog to choose motors from the motion database. When you specify your motor this way, the motor specification data is automatically entered for you. If the motor you are using is not in the Change Catalog list, then it is not in the Motion Database. You have to input the specification data or add a custom motor to the Motion Database that can be selected. For more information, see [Choose Nameplate as the Motor Data Source on page 49](#).

Figure 15 - Example 1: Position Loop with Motor Feedback Only, Scaling Dialog Box

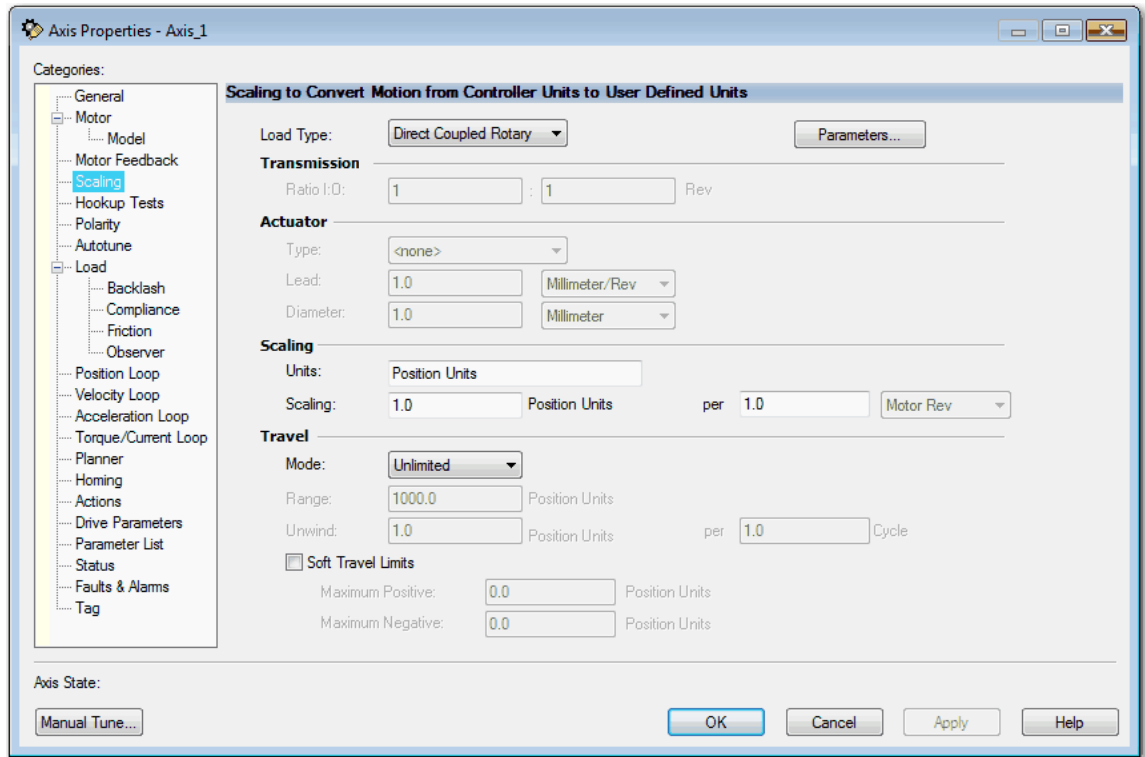

7. Choose the Load Type.
8. Enter the Scaling Units.
9. Choose the Travel Mode.  
For more information about Scaling, see [Scaling on page 119](#).
10. Click Apply.  
You are now finished configuring the axis for Position Loop with Motor Feedback.

## Example 2: Position Loop with Dual Feedback

This example assumes that you have:

- Added your drive to your project.
- Created an associated axis and selected a motor feedback device.
- Added the axis to a motion group.

In this example, you create an AXIS\_CIP\_DRIVE and a Kinetix 6500 drive, which includes the control module and a power structure. You must configure both feedback ports. You must have two feedback cables that are connected to the Kinetix 6500 drive for one axis.

You connect the Motor Feedback cable to the Motor Feedback port, and the Load Feedback cable to the Aux Feedback port of the Kinetix 6500 drive.

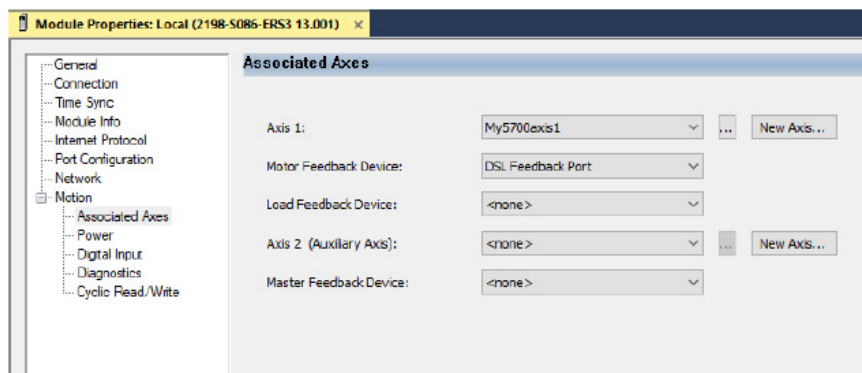

1. Open the Axis Properties.

2. From the Axis Configuration dropdown menu, choose Position Loop.
3. From the Feedback Configuration dropdown menu, choose Dual Feedback.

The axis and feedback configurations determine the control mode.

For more information on the control modes, see the Integrated Motion on the EtherNet/IP Network Reference Manual, publication [MOTION-RM003](#).

**Figure 16 - Example 2: Position Loop with Dual Feedback, General Dialog Box**

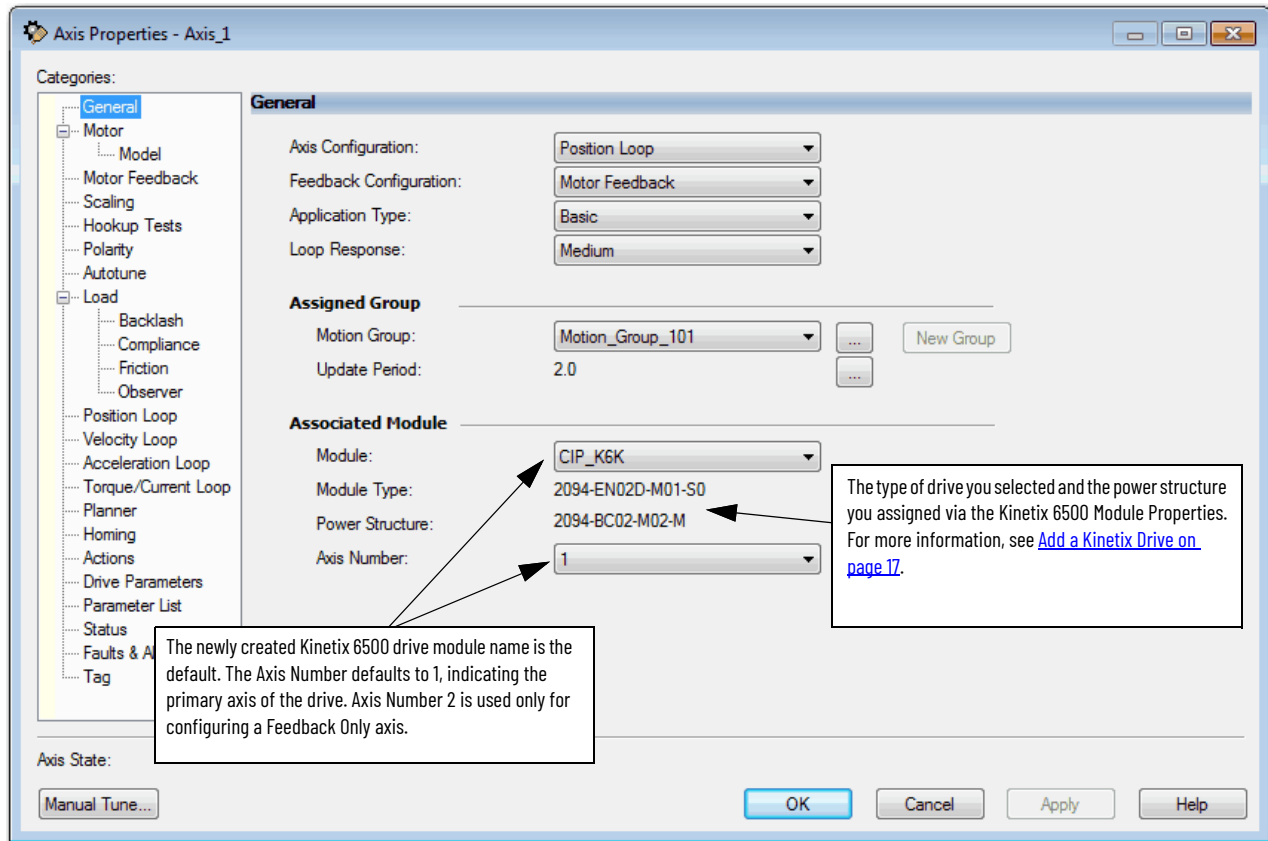

**IMPORTANT** After you have configured the axis and you change the Axis Configuration type or the Axis Number, some of the configuration information is set to default values. This change can cause some previously entered data to be reset back to its default setting.

Now that you defined the axis as being a Position Loop with Dual Feedback axis, the Motor, Motor Feedback, and Load dialog boxes become available.

4. From the Data Source dropdown menu, choose Catalog Number.
5. Click Change Catalog and choose your motor.

In this case, a MPL-B310P-M motor was chosen.

Figure 17 - Example 2: Position Loop with Dual Feedback, Motor Dialog Box

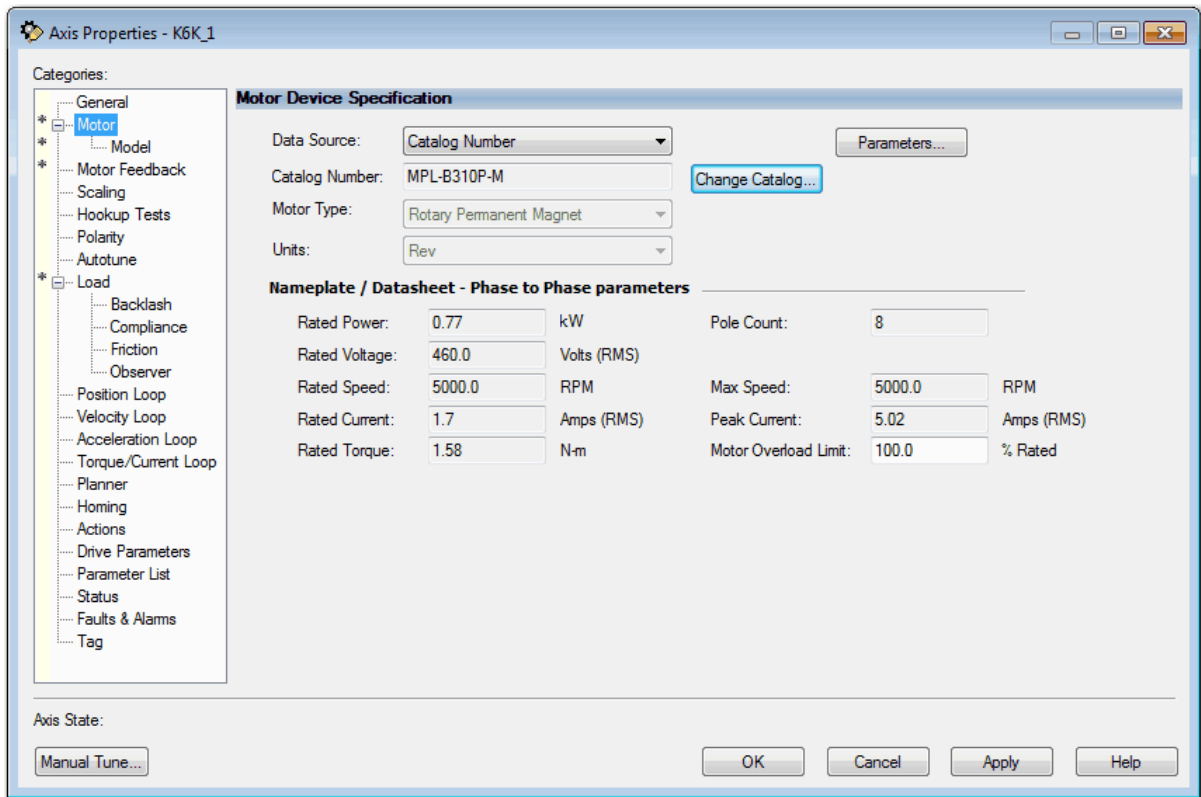

The MPL-B310P-M motor is in the Motion Database, so you can select it by Catalog Number. Notice that the specification data for this motor is automatically entered for you.

If the motor you are using is not in the Change Catalog list, then it is not in the Motion Database. You must input the specification data.

For more information, see [Choose Nameplate as the Motor Data Source on page 49](#).

On the Motor Feedback dialog box, the information is automatically filed in based on your selections on the Motor dialog box.

Figure 18 - Example 2: Position Loop with Dual Feedback, Motor Feedback Dialog Box

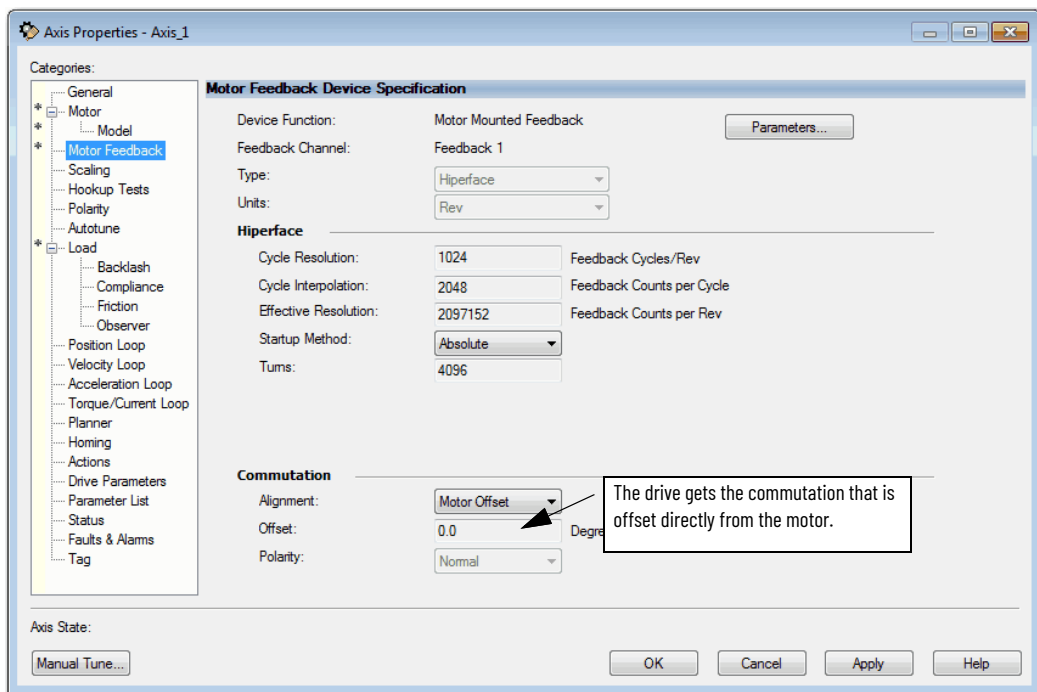

For information about Commutation, see [Assign Motor Feedback on page 53](#) and [Applying the Commutation Hookup Test on page 128](#).

The axis is now configured as the primary feedback. The next task is to configure Feedback 2 on the Load Feedback dialog box.

- To assign the Load Feedback device, click the Define feedback device hyperlink or go to the Module Properties of the drive.

**Figure 19 - Example 2: Position Loop with Dual Feedback, Load Feedback Dialog Box, Load-side Feedback**

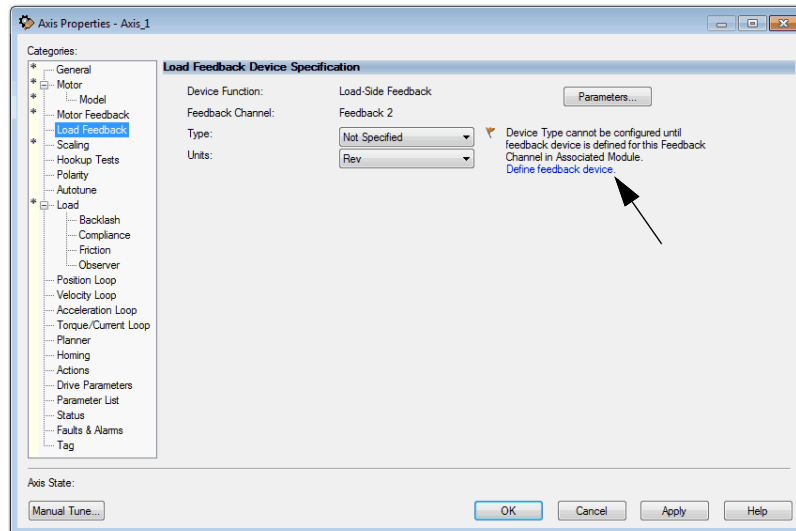

- From the Load Feedback Device dropdown menu, choose Aux Feedback Port.
- To apply your changes and return to the Load Feedback dialog box, click OK.

**Figure 20 - Example 2: Kinetix 6500 Module Properties, Associated Axis Tab**

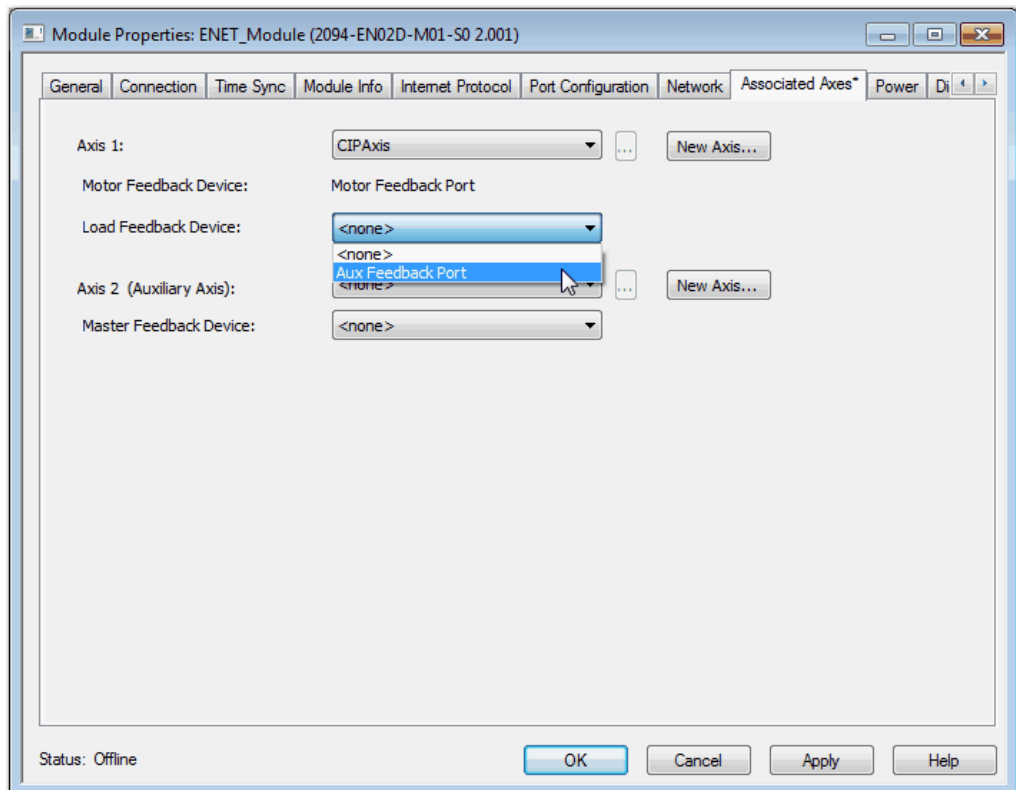

- Choose the Feedback Type and Units.

Figure 21 - Example 2: Position Loop with Dual Feedback, Load Feedback Dialog Box

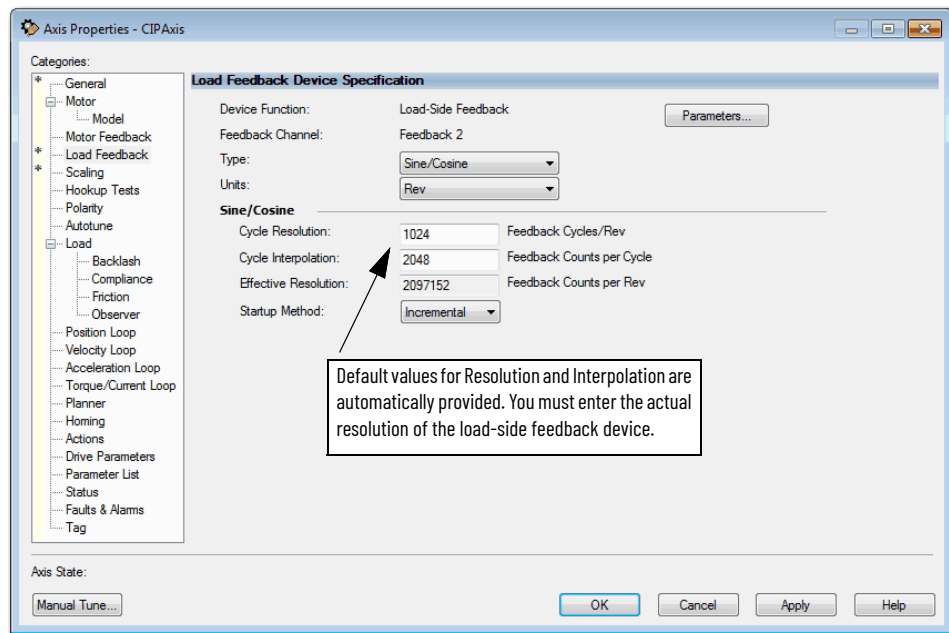
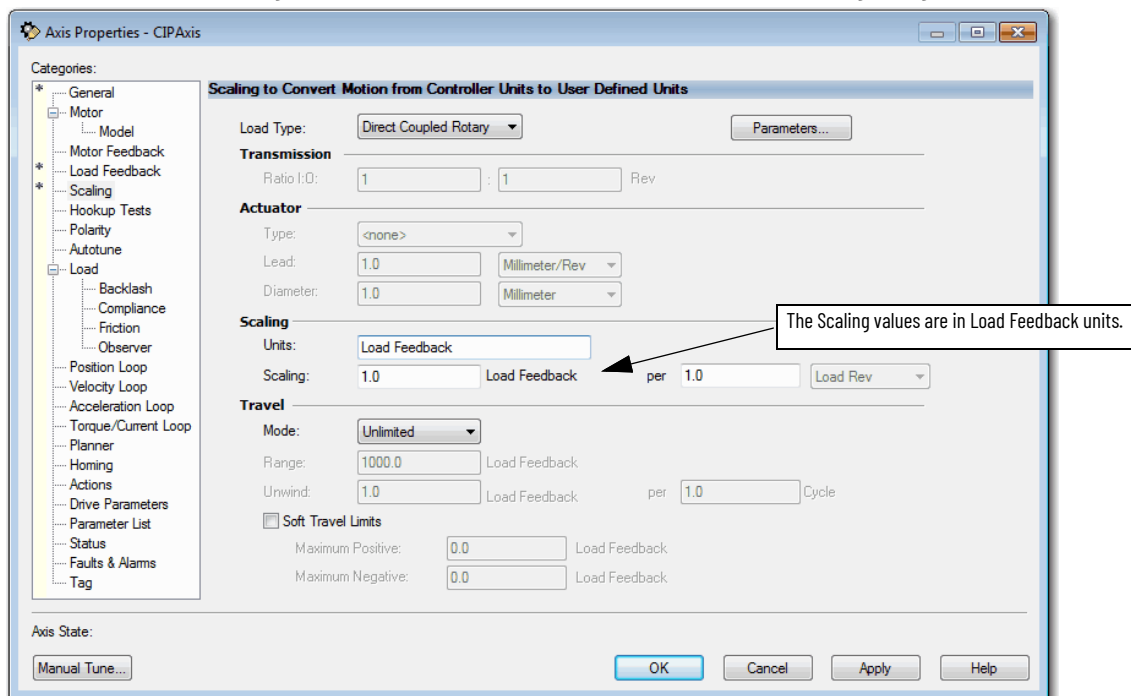

Figure 22 - Example 2: Position Loop with Dual Feedback, Scaling Dialog Box



You are now finished configuring the axis as Position Loop axis with Dual Feedback.

10. To apply your changes and close Axis Properties, click OK.

### Example 3: Feedback Only

In this example, you create a half-axis AXIS\_CIP\_DRIVE type by using the AUX Feedback port of the drive for Master Feedback. You must connect the Master Feedback device cable to the Aux Feedback port of the Kinetix 6500 drive.



You can use feedback only axes, for example, as a master reference for gearing, with PCAM moves, and MAOC output CAMs.

1. From the Axis Configuration dropdown menu, choose Feedback Only.
2. From the Feedback Configuration dropdown menu, choose Master Feedback. This selection determines the control mode.

For more information, see the Integrated Motion on the EtherNet/IP network Reference Manual, publication [MOTION-RM003](#).

- From the Module dropdown menu, choose the associated module that you want to use for the Master Feedback device.

Figure 23 – Example 3: Feedback Only with Master Feedback, General Dialog Box

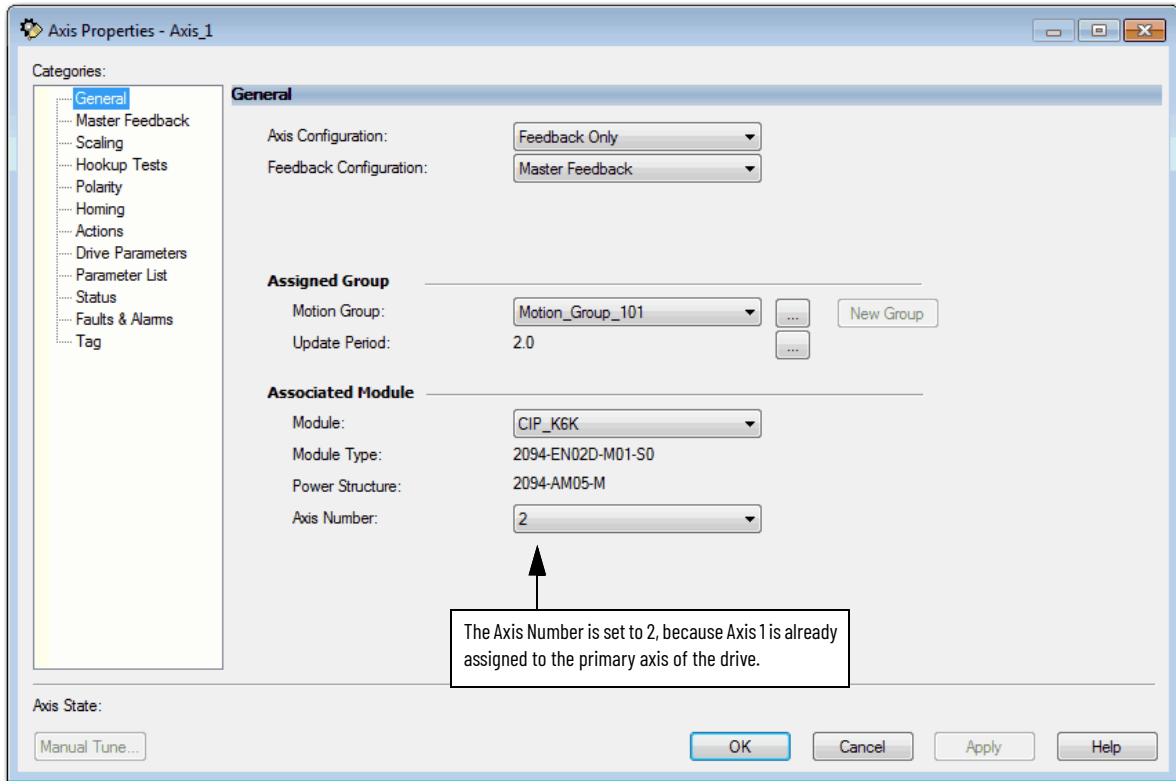

- To associate the drive with the axis, click the Define feedback device hyperlink.

Figure 24 – Example 3: Feedback Only with Master Feedback, Master Feedback Dialog Box

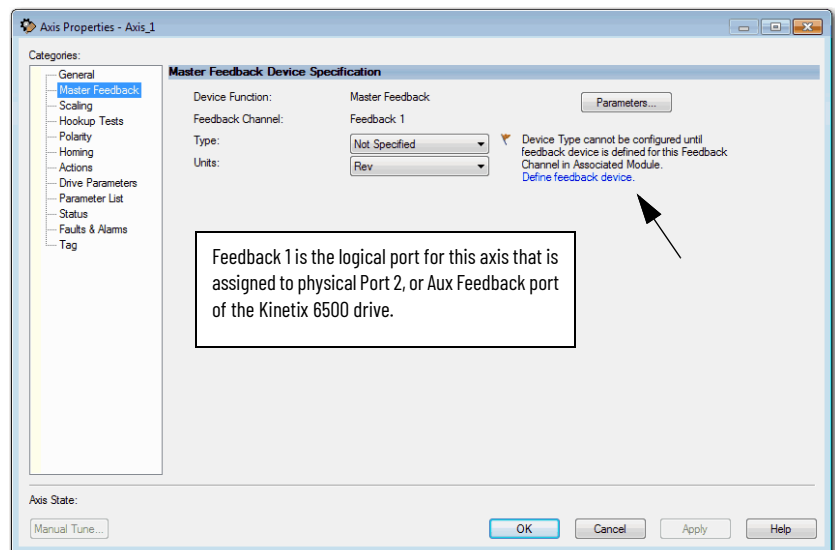

- From the Axis2(AuxiliaryAxis)dropdown menu, chooseAxis\_IV\_Feedback Only to associate the axis.

Figure 25 - Example 3: Master Feedback Dialog Box

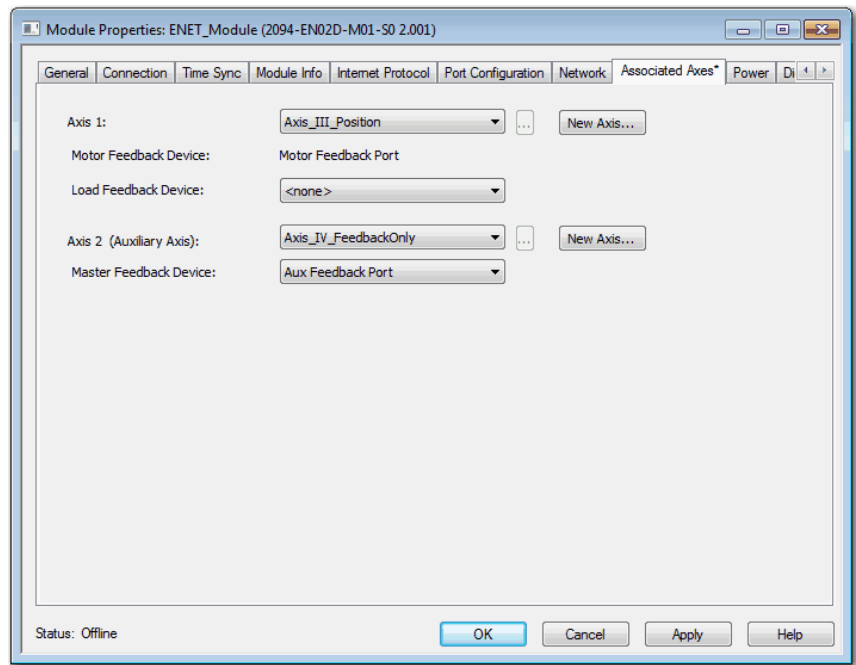

- From the Master Feedback Device dropdown menu, choose Aux Feedback Port to map the port to the device.



The available ports are different for the Kinetix 5700 drives.

- To apply your changes and return to Axis Properties, click OK.

Figure 26 - Example 3: Feedback Only with Master Feedback, Master Feedback Dialog Box

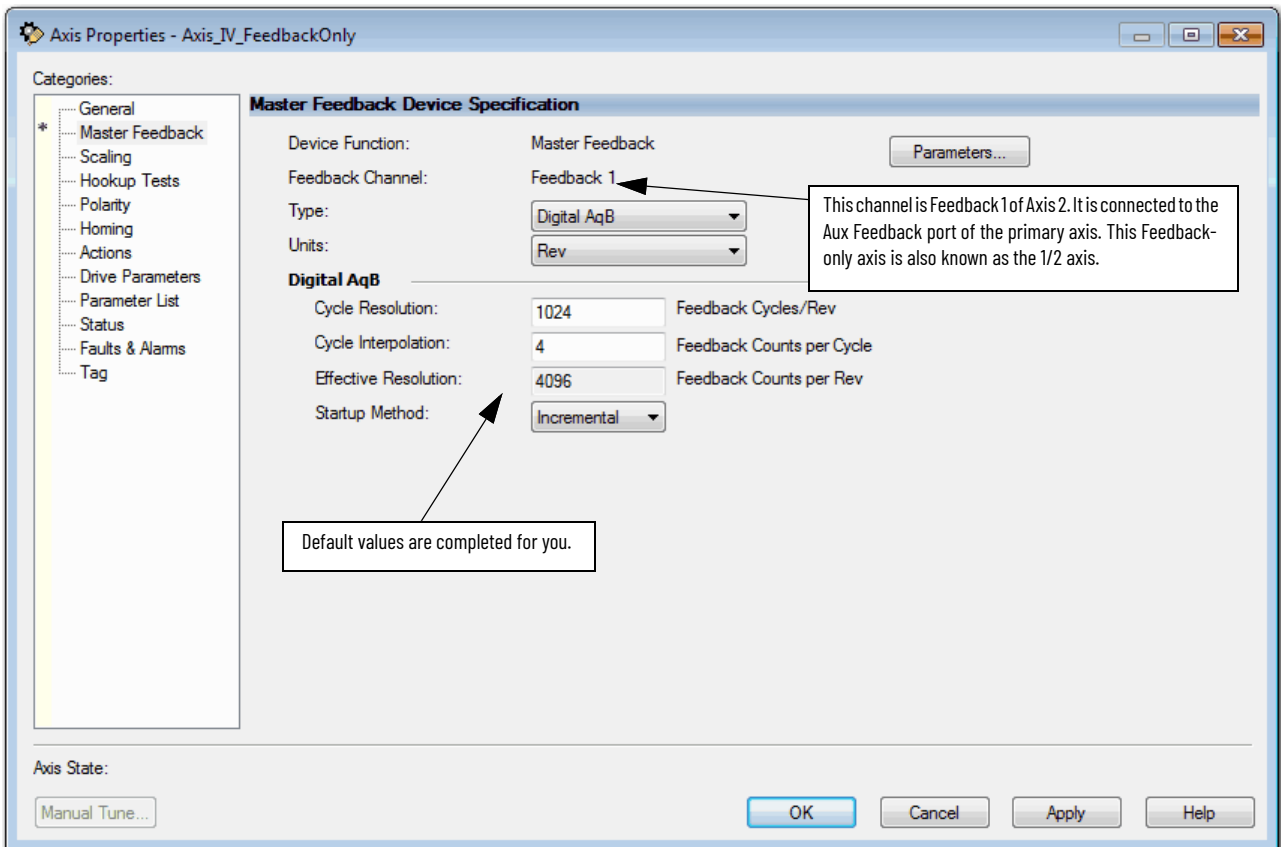

8. From the Type dropdown menu, choose Digital AqB as the feedback type.
9. From the Units dropdown menu, choose Rev.
10. In the appropriate field, type the resolutions of your specific feedback device.

Figure 27 – Example 3: Feedback Only with Master Feedback, Scaling Dialog Box

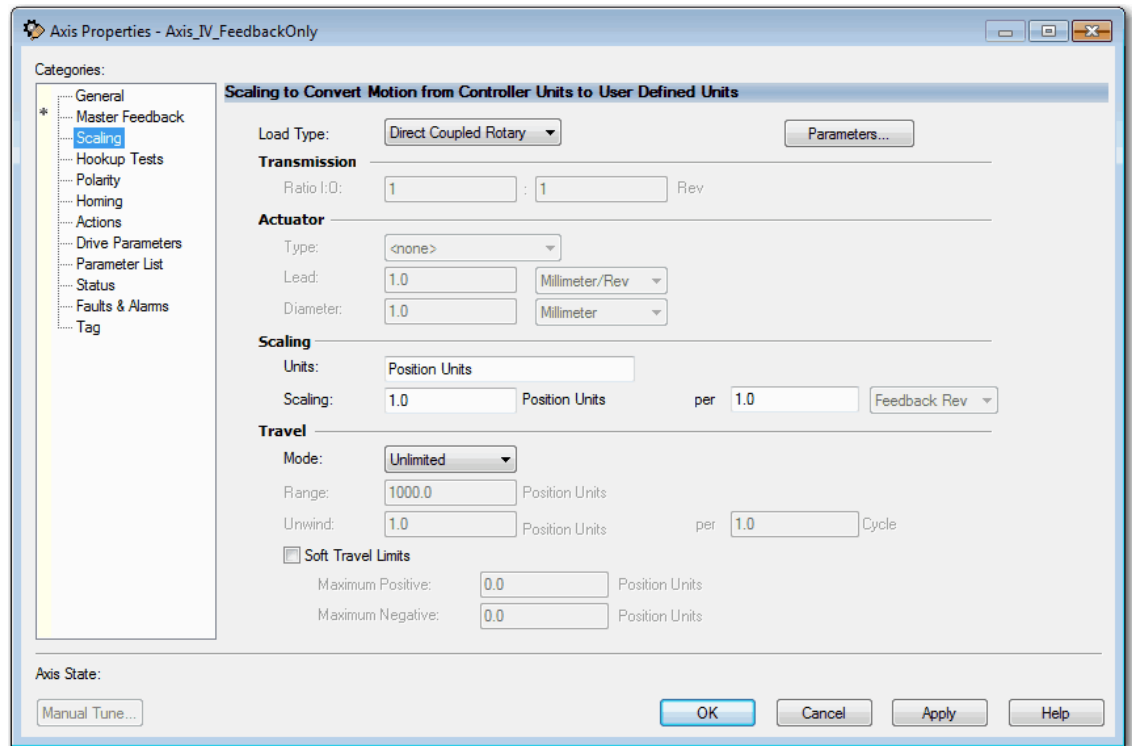

11. From the Load Type dropdown menu, choose your load type.
12. Enter the Scaling Units.
13. From the Mode dropdown menu, choose your Travel mode.  
For more information about Scaling, see [Scaling on page 119](#).
14. Click Apply.  
You are now finished configuring an axis for Feedback Only.

## Example 4: Kinetix 5500 Drive, Velocity Loop with Motor Feedback

In this example, you are configuring a Kinetix 5500 servo drive, catalog number 2098-H025-ERS, with motor feedback by using a Rotary Permanent Magnet motor, catalog number VPL-A1001M-P.

You must connect the Motor Feedback cable to the Motor Feedback port of the Kinetix 5500 drive and then configure the feedback port.

1. Once you have added the drive to your project and created an AXIS\_CIP\_DRIVE, open the Axis Properties.

Figure 28 - Example 4: Velocity Loop with Motor Feedback, General Dialog Box

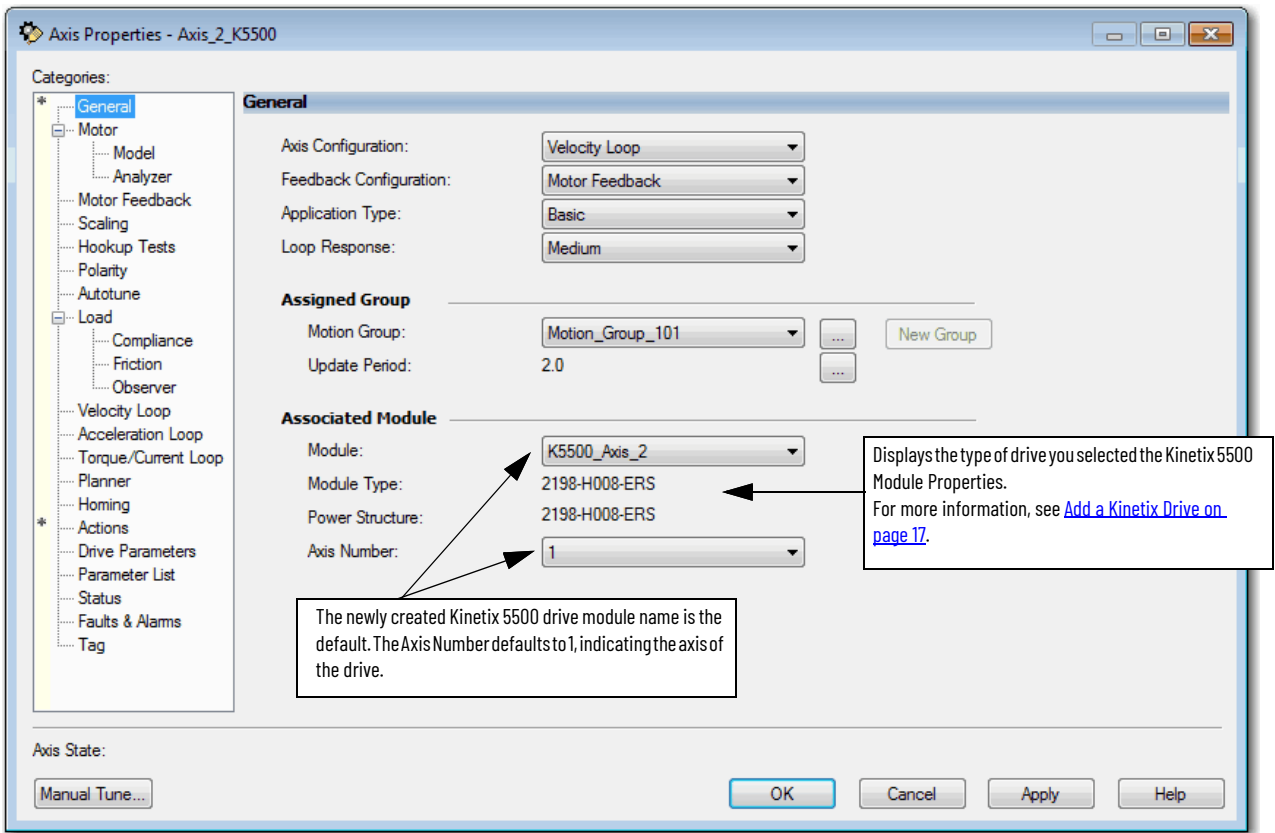

After you have configured the axis and you change the Axis Configuration type or the Axis Number, some of the configuration information is set to default values. This change can cause some previously entered data to be reset back to its default setting.

After you select Velocity Loop with Motor Feedback, the Motor and Motor Feedback dialog boxes become available.

2. Click the Motor dialog box.
3. Choose Catalog Number as the Motor Data Source.
4. Click Change Catalog and choose your motor, for example, catalog number VPL-B0631T-C.

Figure 29 - Example 4: Velocity Loop with Motor Feedback, Motor Dialog Box

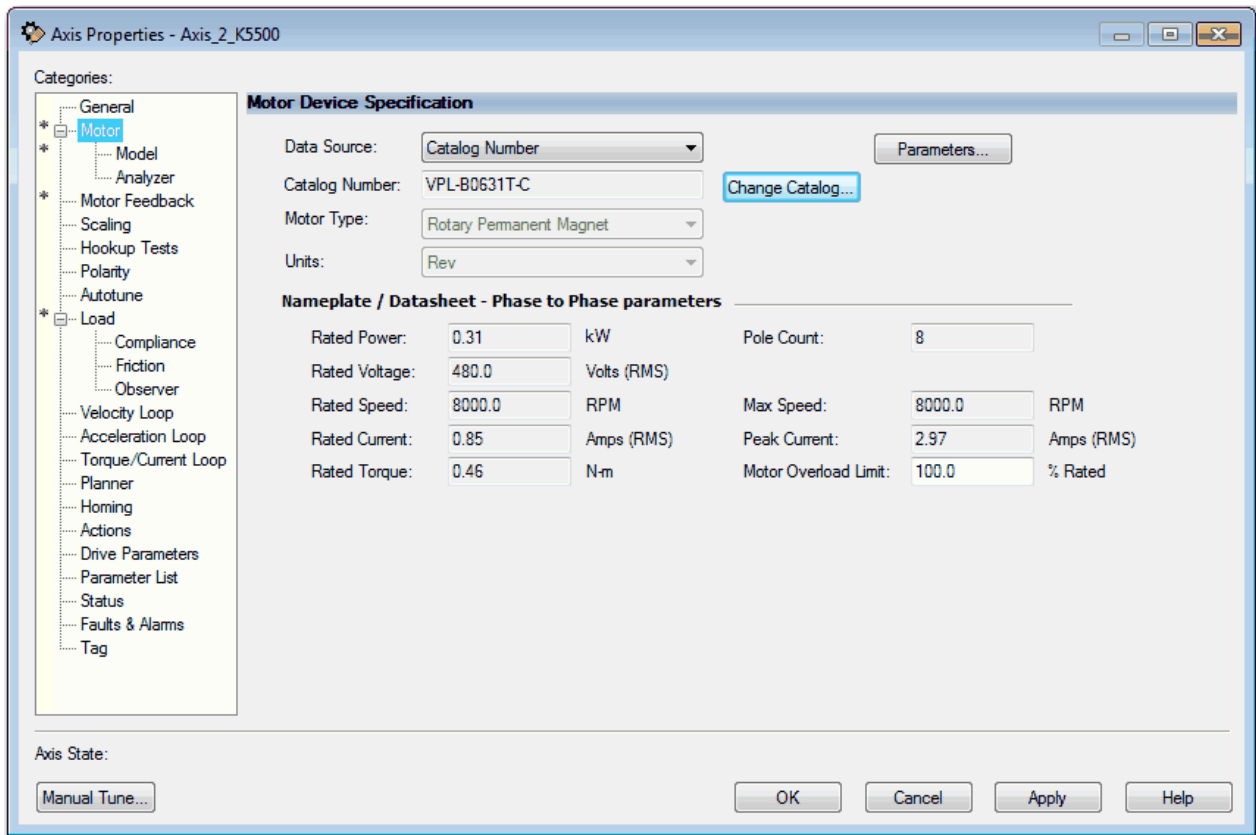

When you select the Catalog Number for the motor specification, the VPL-B0631T-C motor is in the Motion Database. The specification data for this motor is automatically completed for you.

If the motor you are using is not in the Change Catalog list, then it is not in the Motion Database. You must input the specification data or add a custom motor to the Motion Database that can be selected.

For more information, see [Choose Nameplate as the Motor Data Source on page 49](#).

5. Click the Motor Feedback dialog box.

Figure 30 - Example 4: Velocity Loop with Motor Feedback, Motor Feedback Dialog Box

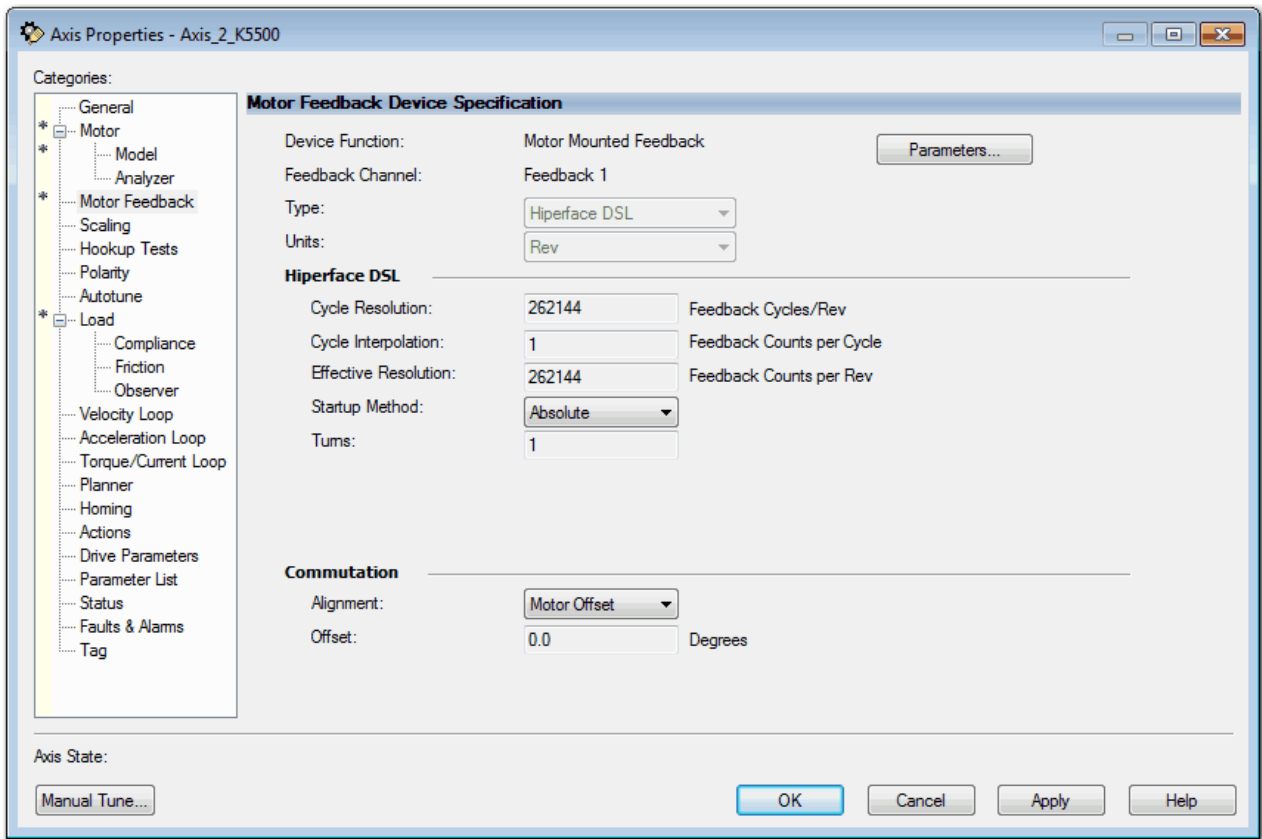

With this drive and motor combination, the Motor-Mounted Feedback that is available is the Hiperface DSL type. The data is automatically populated based on that selection. You can assign the commutation alignment.

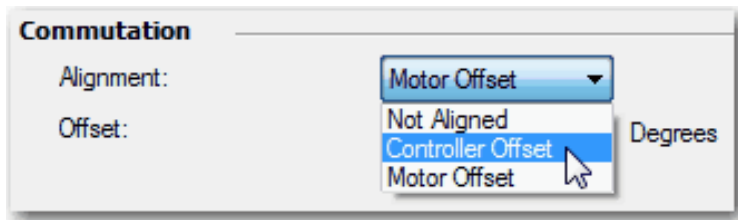

- To adjust the Scaling attributes, click the Scaling dialog box.

Figure 31 - Example 4: Velocity Loop with Motor Feedback, Scaling Dialog Box

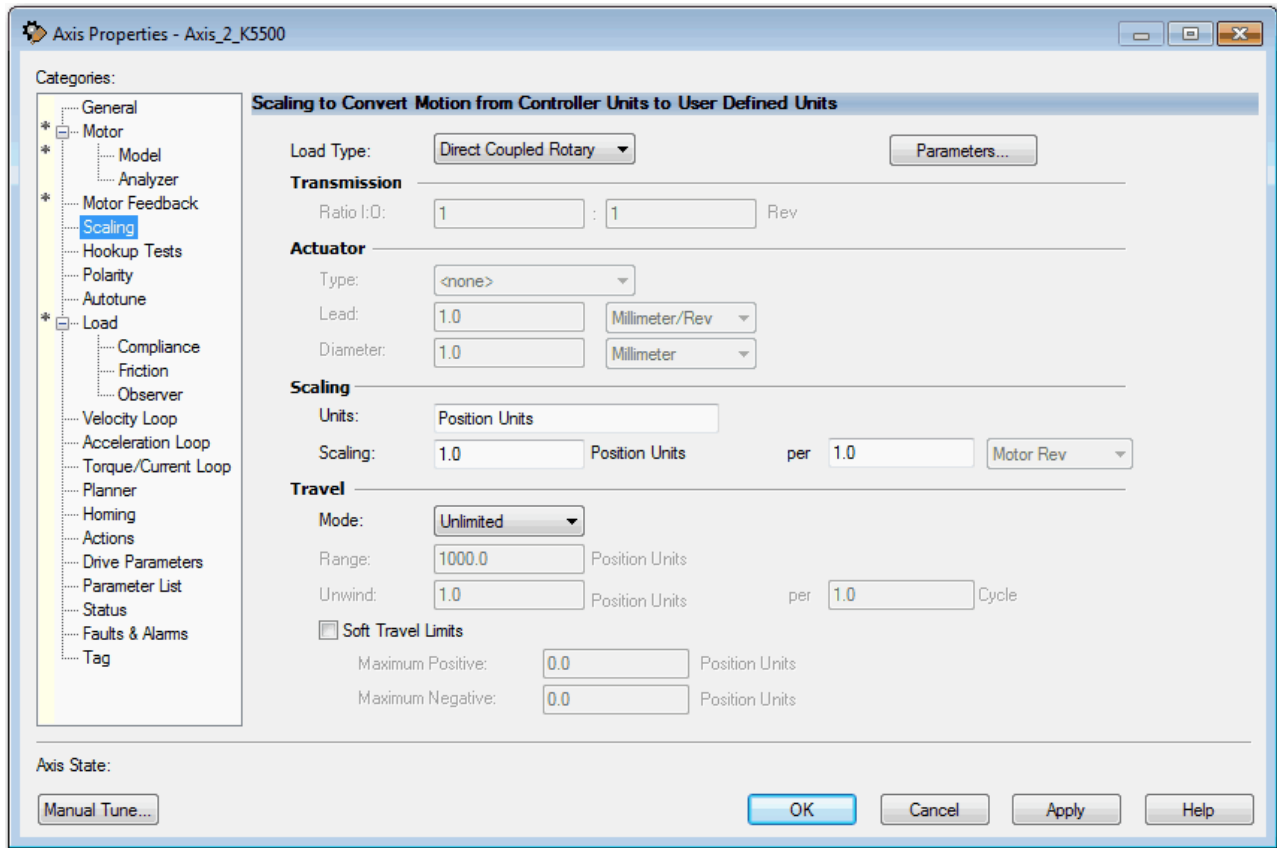

7. Choose the Load Type.
8. Enter the Scaling Units.
9. Choose the Travel Mode.

For more information about Scaling, see [Scaling on page 119](#).

10. Click Apply.

You are now finished configuring the Kinetix 5500 axis for Velocity Loop with Motor Feedback.

## Example 5: Kinetix 5700 Drive, Frequency Control with No Feedback

In this example, create a project with a ControlLogix® controller, for example, 1756-L73S. You are configuring a Kinetix 5700 drive, catalog number 2198-D006-ERS3, with no feedback by using a HPK-Series High-power Servo motor.

1. Once you have added the drive to your project and created an AXIS\_CIP\_DRIVE, open the Axis Properties.
2. From the Axis Configuration dropdown menu, choose Frequency Control.  
At the Feedback Configuration dropdown menu, No Feedback is the only option.

Figure 32 – Example 6: Frequency Control with No Feedback, General Dialog Box

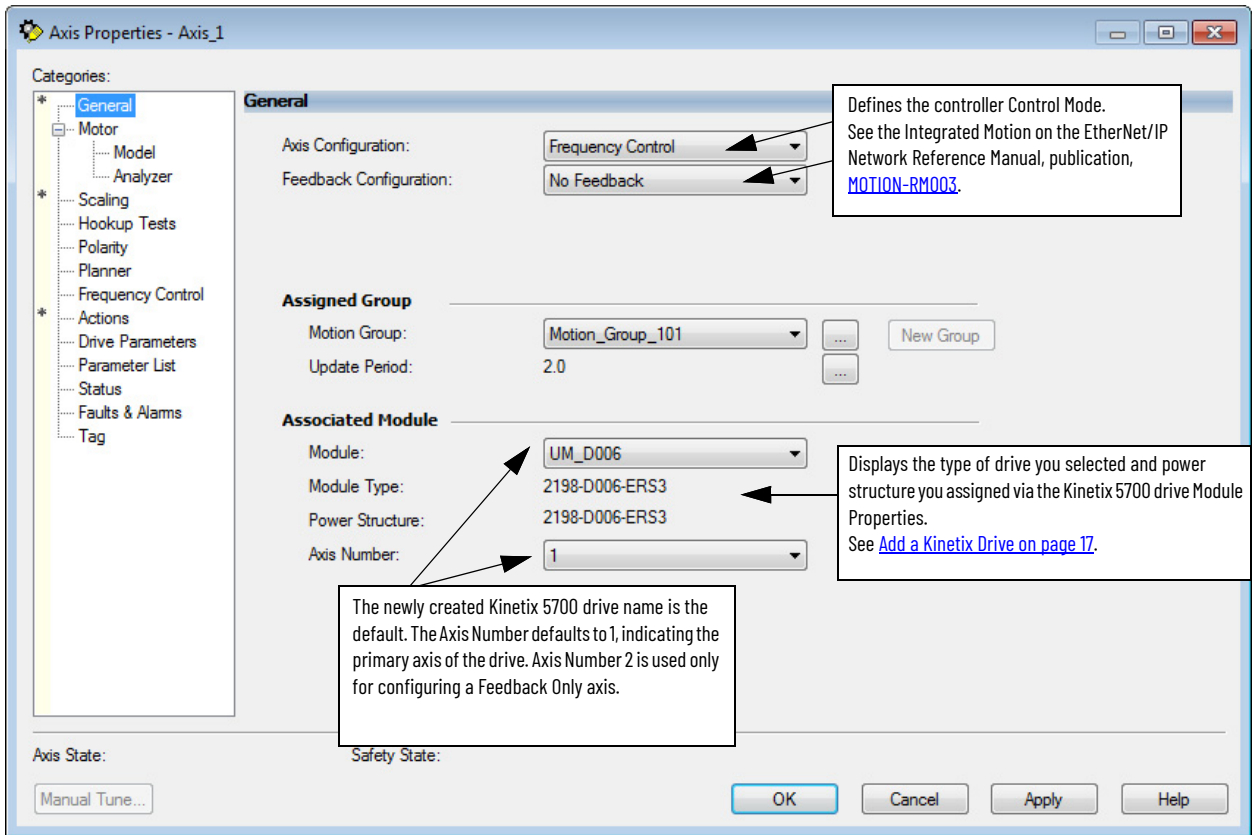

- From the Data Source dropdown menu, choose a data source.  
In this case, the data source is Catalog Number and the Motion Database provides values for these fields.  
See the [Display Motor Model Information on page 51](#) for more information about data sources.

Figure 33 – Example 6: Frequency Control with No Feedback, Motor Dialog Box

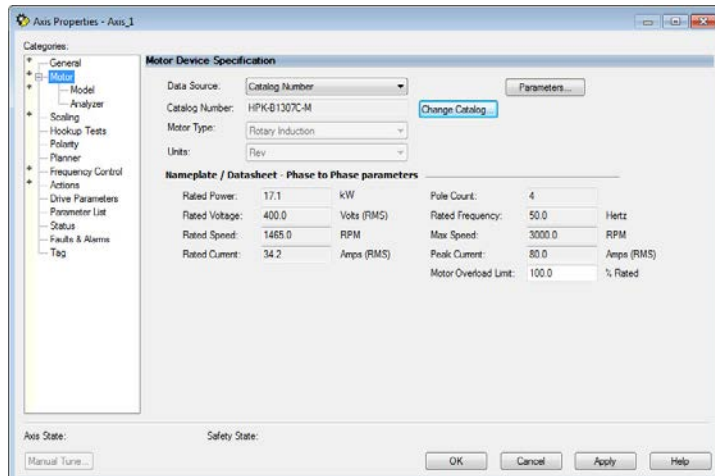

- From the Frequency Control Method dropdown menu, choose the appropriate method.  
This example uses Basic Volts/Hertz.
- Click Apply.

Figure 34 – Example 5: Frequency Control with No Feedback, Frequency Control Dialog Box

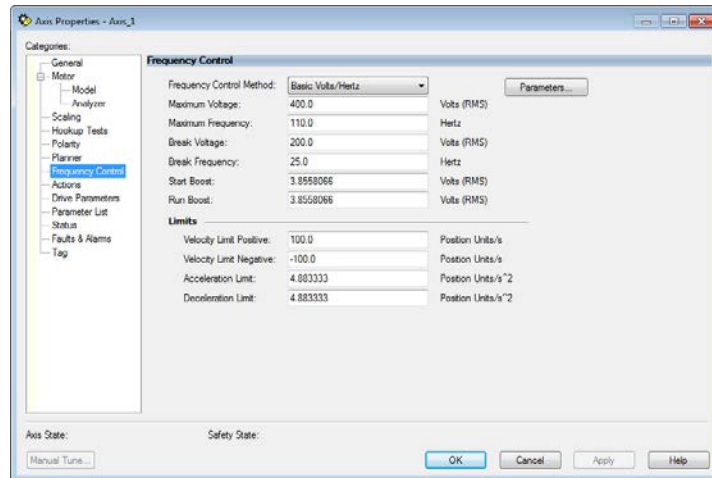

- From the Load Type dropdown menu, choose the appropriate load type.

Figure 35 – Example 6: Frequency Control with No Feedback, Scaling Dialog Box Conversion Units

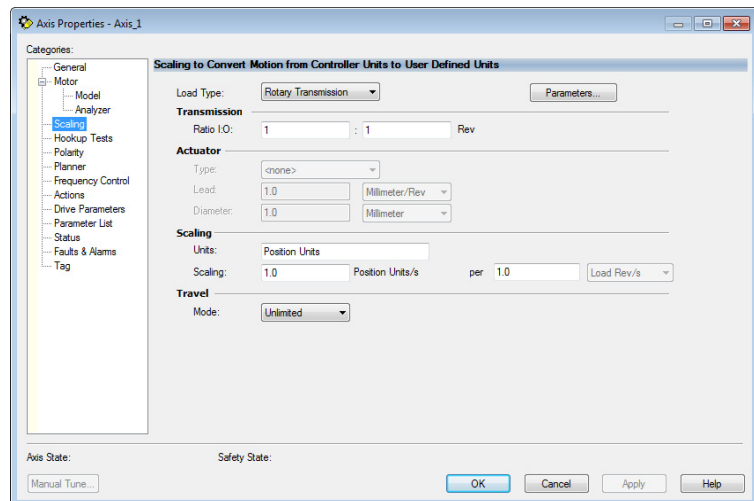

- Enter the Transmission Ratio.
- From the Actuator Type dropdown menu, choose the appropriate actuator, if applicable.
- Enter the Diameter dimensions.
- Enter the Scaling Units.  
See the [Scaling on page 119](#) for more information.
- From the Travel Mode dropdown menu, choose the appropriate travel mode.
- Click Apply.

You are now finished configuring the axis for Frequency Control with No Feedback.

## Example 6: 842E-CM Integrated Motion Encoder with Master Feedback

In this example, create a project with a ControlLogix controller, for example, 1756-L73. You are configuring an 842E-CM encoder, catalog number 842-CM-M, with feedback only.

- In the Controller Organizer, right-click Ethernet under the I/O Configuration folder and choose New Module.  
The Select Module Type dialog box appears.

Figure 36 – Example 7: Select Module Type Dialog Box

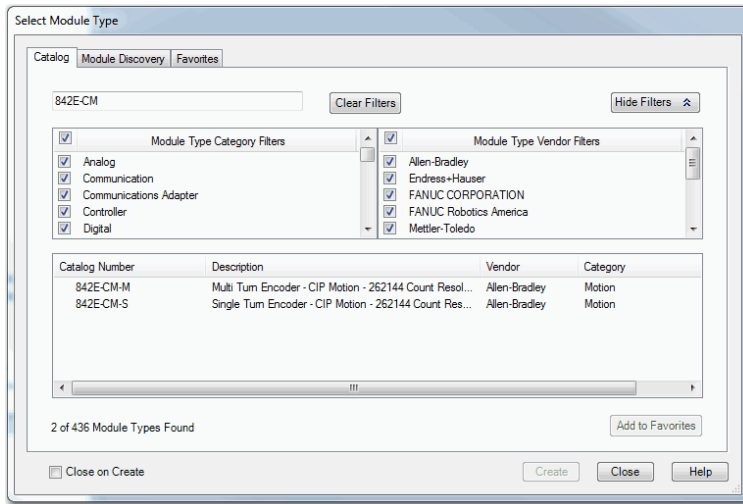

2. Select your 842E-CM encoder as appropriate for your actual hardware configuration.
3. Click Create.

The New Module dialog box appears.

Figure 37 – Example 7: New Module Dialog Box

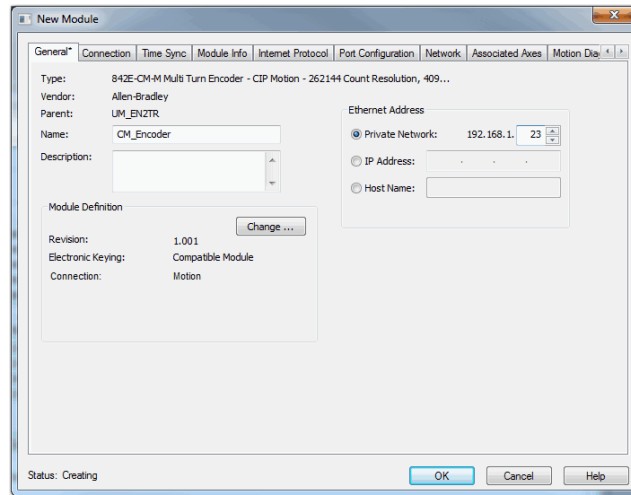

4. Configure the 842E-CM encoder.
  - a. Type the encoder Name.
  - b. Select an EtherNet/IP address option.
 

In this example, the Private Network address is selected.
  - c. Enter the address of your EtherNet/IP™ module.
 

In this example, the last octet of the address is 23.
5. To close the New Module dialog box, click OK.
6. To close the Select Module, click Close.
 

Type dialog box.
7. Right-click the 842E-CM encoder that you created and choose Properties.
 

The Module Properties dialog box appears.
8. Configure the Associated Axis tab and the motion group for your 842E-CM encoder.
 

In this example, the feedback-only axis is named Master\_Fdbk.
9. In the Controller Organizer, right-click the feedback-only axis and choose Properties.
10. Select the General category.

**Figure 38 – Example 7: 842E-CM Integrated Motion Encoder with Master Feedback, General Dialog Box**

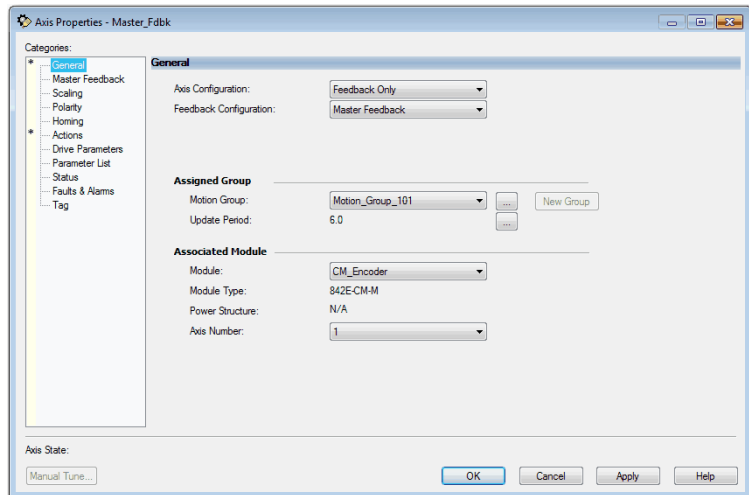

11. From the Module dropdown menu, choose the 842E-CM encoder to associate with your Feedback Only axis.  
The Module Type field populates with the chosen encoder catalog number.
12. Select the Master Feedback category.

**Figure 39 – Example 7: 842E-CM Integrated Motion Encoder with Master Feedback, Master Feedback Dialog Box**

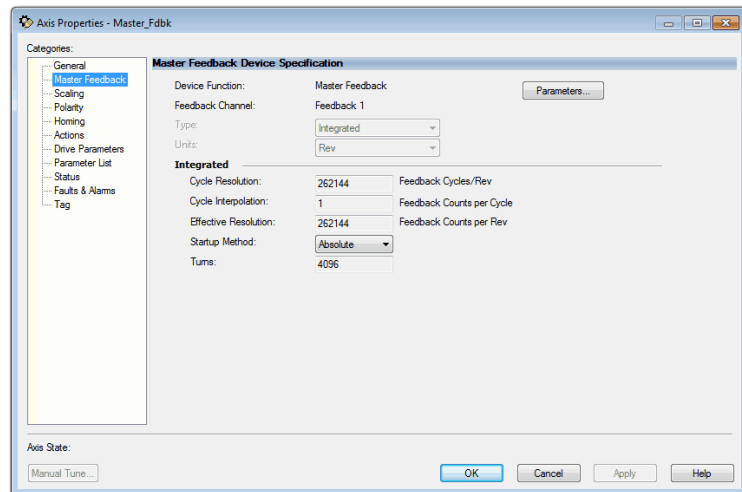

The Type and Units appear dim. The Cycle Resolution, Cycle Interpolation, Effective Resolution, and Turns are automatically completed with values from the AOP schema. The selections for the Master Feedback category are automatic to make sure that valid values are entered.

13. Click OK.

**Notes:**

## Axis Configuration Examples for the PowerFlex 755 Drive

This chapter provides example axis configurations when using a PowerFlex® 755 drive.



For axis configuration examples when using a PowerFlex 755T drive, see *Integrated Motion on EtherNet/IP Networks for PowerFlex Drives with TotalFORCE Application Technique*, publication [750-AT007](#).

The following six examples are typical axis-configuration applications for the PowerFlex 755 drive:

- Position Loop with Motor Feedback
- Position Loop with Dual Feedback
- Velocity Loop with Motor Feedback
- Velocity Control with No Feedback
- Frequency Control with No Feedback
- Torque Loop with Feedback

### Example 1: Position Loop with Motor Feedback Via a UFB Feedback Device

This example describes how to create an AXIS\_CIP\_DRIVE axis that is associated to a PowerFlex 755 drive with motor feedback via a universal feedback device, catalog number 20-750-UFB-1.



Remember that you already assigned the feedback device when you added the drive to your project.

See [Create an Axis on page 37](#) for more information about feedback devices.

1. Once you have created an AXIS\_CIP\_DRIVE, open the Axis Properties.
  2. From the Axis Configuration dropdown menu, choose Position Loop.
- When you choose the configuration type, it determines the Control Mode.

See the *Integrated Motion on the EtherNet/IP Network Reference Manual*, publication [MOTION-RM003](#).

**Figure 40 - Example 1: Position Loop with Motor Feedback, General Dialog Box**

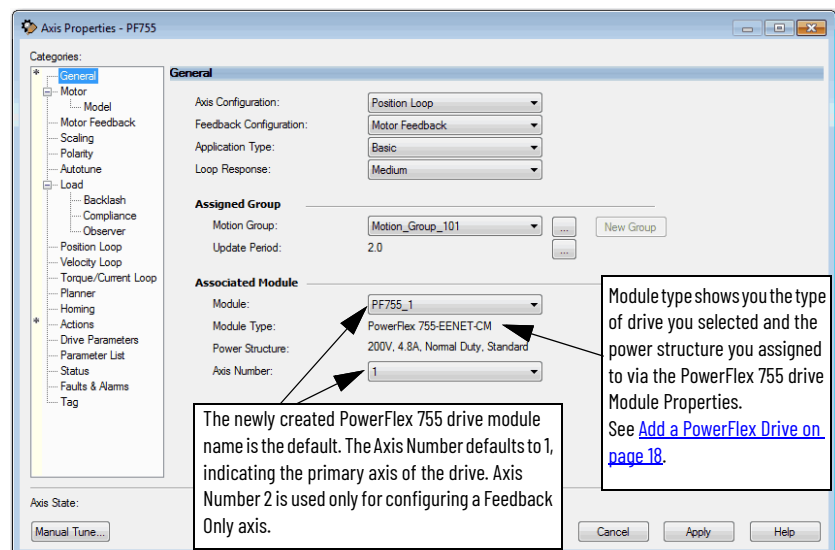

3. From the Feedback Configuration dropdown menu, choose Motor Feedback.



After you have configured the axis and you change the Axis Configuration type or the Axis Number, some of the configuration information is set to default values. This change can cause some previously entered data to be reset back to its default setting.

Now that you defined the axis as being a Position Loop with Motor Feedback, the Motor and Motor Feedback dialog boxes become available.

Figure 41 - Example 1: Position Loop with Motor Feedback, Motor Dialog Box

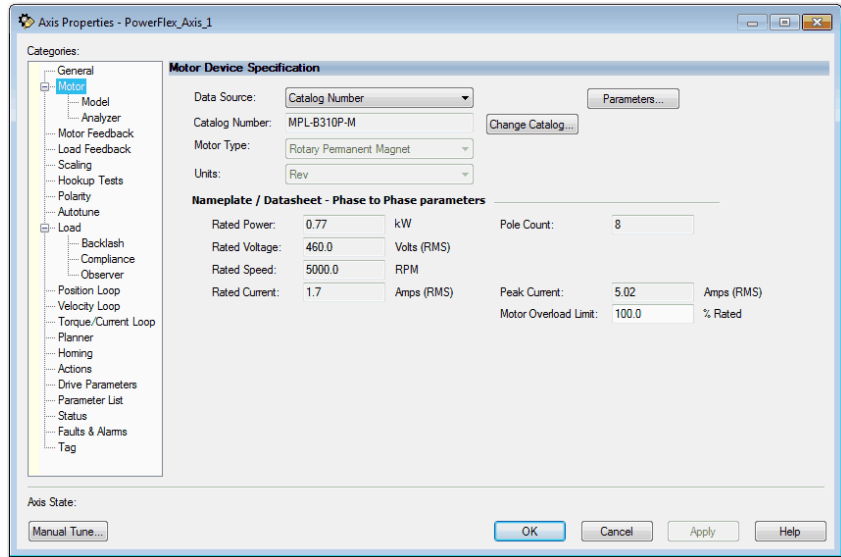

4. Choose Catalog Number as the Data Source.
5. Click Change Catalog and choose a motor.

When you select the Catalog Number for the motor specification, the MPL-B310P-M motor is in the Motion Database. The specification data for this motor is automatically entered for you. If the motor you are using is not in the Change Catalog list, then it is not in the Motion Database. You have to enter the specification data on your own.

The Motor Feedback dialog box is automatically filled based on your motor selection.

Figure 42 - Example 1: Position Loop with Motor Feedback, Motor Feedback Dialog Box

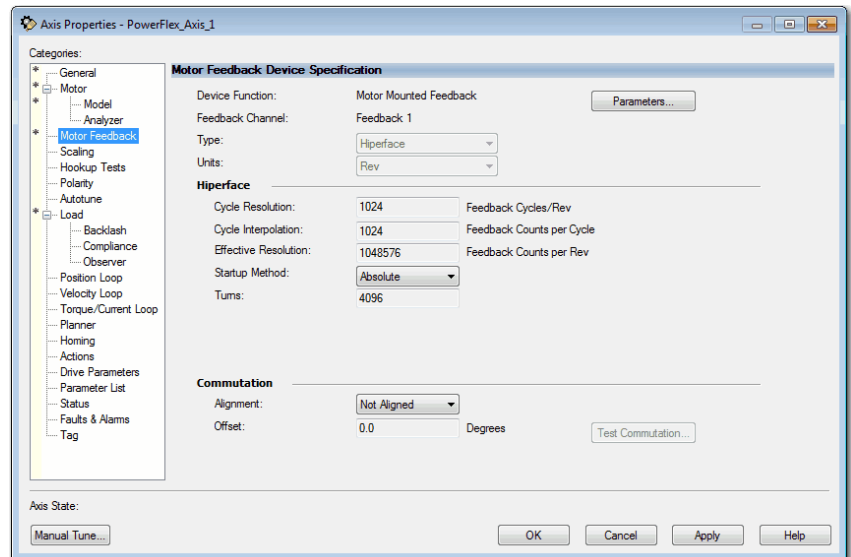

6. Choose the Commutation Alignment.

For more information about Commutation, see [Assign Motor Feedback on page 53](#) and [Applying the Commutation Hookup Test on page 128](#).

Figure 43 – Example 1: Position Loop with Motor Feedback, Scaling Dialog Box

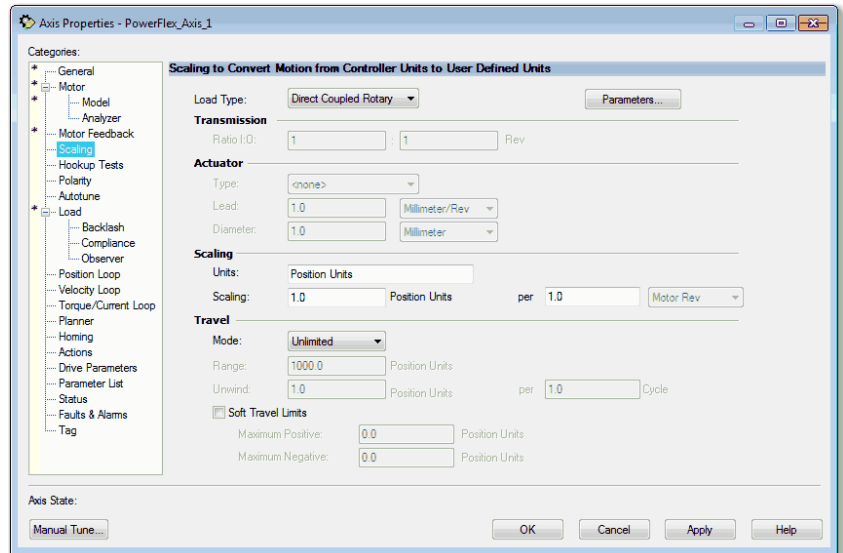

7. From the Load Type dropdown menu, choose your type of load.
8. Enter the Scaling Units.
9. From the Travel Mode dropdown menu, choose your Travel Mode.  
For more information about Scaling, see [Scaling on page 119](#).
10. Click Apply and OK to exit Axis Properties.

The axis is now configured for Position Loop with Motor Feedback.

## Example 2: Position Loop with Dual Motor Feedback Via a UFB Feedback Device

This example describes how to create an AXIS\_CIP\_DRIVE axis that is associated to a PowerFlex 755 drive with dual motor feedback via a universal feedback device, catalog number 20-750-UFB-1.



Remember that you already assigned the feedback device when you added the drive to your project.

See [Create an Axis on page 37](#) for more information about feedback devices.

1. Once you have created an AXIS\_CIP\_DRIVE, open the Axis Properties.
2. From the Axis Configuration dropdown menu, choose Position Loop.
3. From the Feedback Configuration dropdown menu, choose Dual Feedback.

When you choose the configuration type, it determines the Control Mode.

See the Integrated Motion on the EtherNet/IP Network Reference Manual, publication [MOTION-RM003](#).

Figure 44 - Example 2: Position Loop with Dual Feedback, General Dialog Box

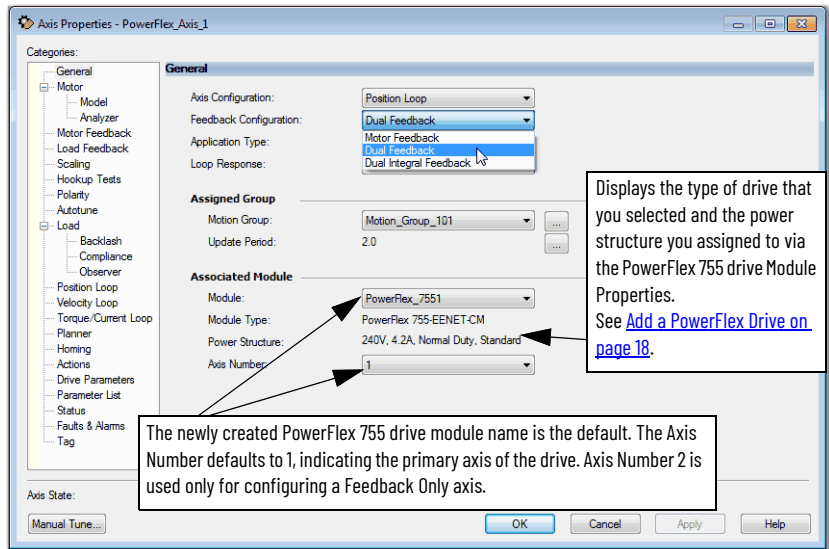

**IMPORTANT**

After you have configured the axis and you change the Axis Configuration type or the Axis Number, some of the configuration information is set to default values. This change can cause some previously entered data to be reset back to its default setting.

Now that you defined the axis as being a Position Loop with Dual Feedback axis, the Motor Feedback, and Load Feedback dialog boxes become available.

- From the Data Source dropdown menu, choose Catalog Number.

Figure 45 - Example 2: Position Loop with Dual Feedback, Motor Dialog Box

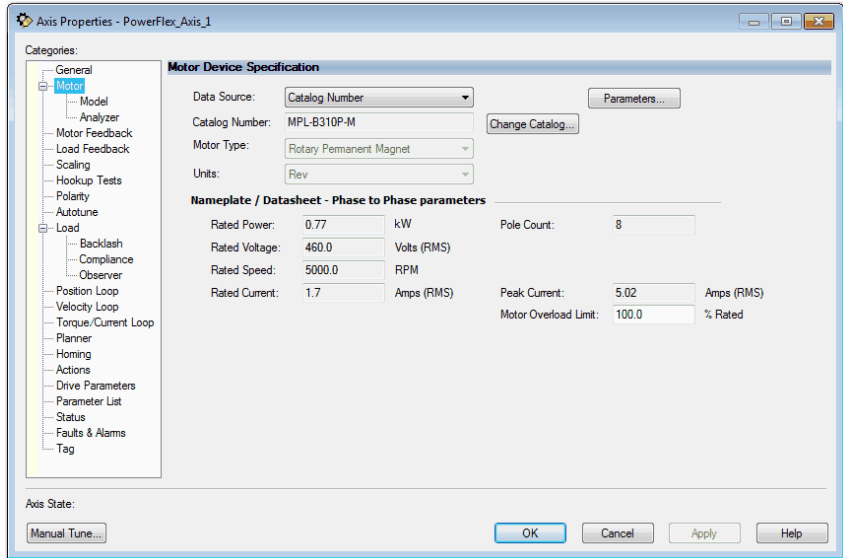

- Click Change Catalog and choose your motor. In this case, a MPL-B310P-M motor was chosen.

When you select the Catalog Number for the motor specification, the MPL-B310P-M motor is in the Motion Database. The specification data for this motor is automatically entered for you. If the motor you are using is not listed in the Change Catalog, then it is not in the Motion Database. You have to enter the specification data on your own.

The Motor Feedback dialog box is automatically filled based on your motor selection.

Figure 46 - Example 2: Position Loop with Dual Feedback, Motor Feedback Dialog Box

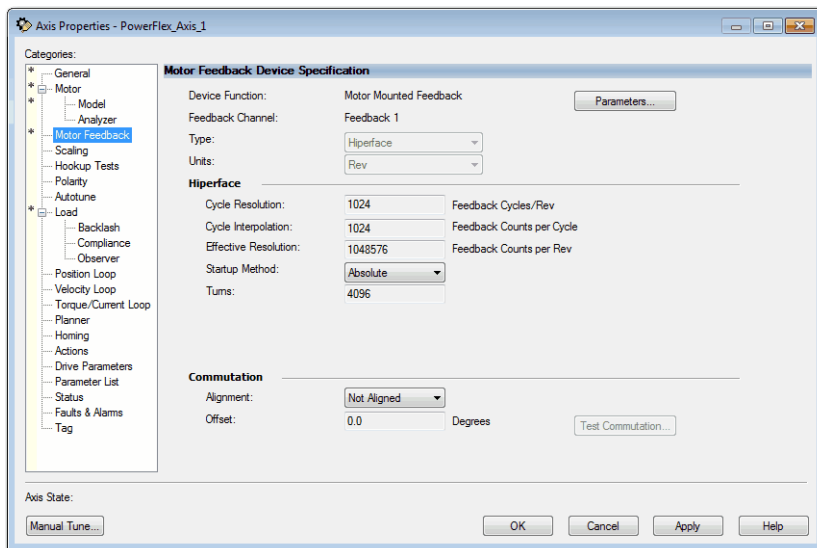

6. Choose the Commutation Alignment.

For more information about Commutation, see [Applying the Commutation Hookup Test on page 128](#).

On the Motor Feedback dialog box, the information is automatically based on your selections on the Motor dialog box.

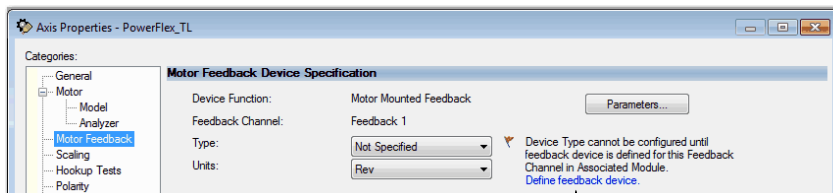

If you have not defined a feedback device, the motor dialog box displays a link to the module definition for the drive.

The axis is now configured as a Position Loop with two feedback devices. The next task is to configure Feedback 2 on the Load Feedback dialog box.

Follow these instructions to define the Load feedback.

1. From the Load Feedback dialog box, click the Define feedback device hyperlink.

**Figure 47 - Example 2: Load-side Feedback, Load Feedback Dialog Box**

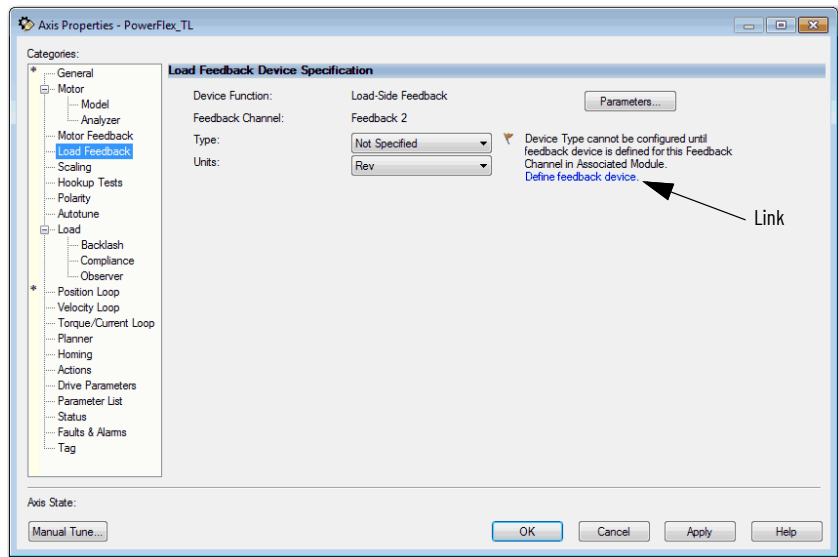

2. Click Associated Axes in Module Properties dialog box.
3. From the Load Feedback Device dropdown menu, choose the appropriate port/channel for the Load Feedback Device.

**Figure 48 - Example 2: PowerFlex 755 Module Properties, Associated Axis Tab**

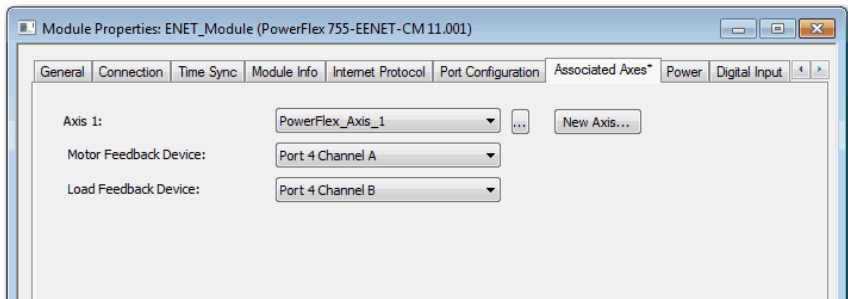

4. From the Type dropdown menu, choose the type of feedback.
5. From the Units dropdown menu, choose the appropriate units.
6. Click Apply.

Figure 49 - Example 2: Load-side Feedback, Load Feedback Dialog Box

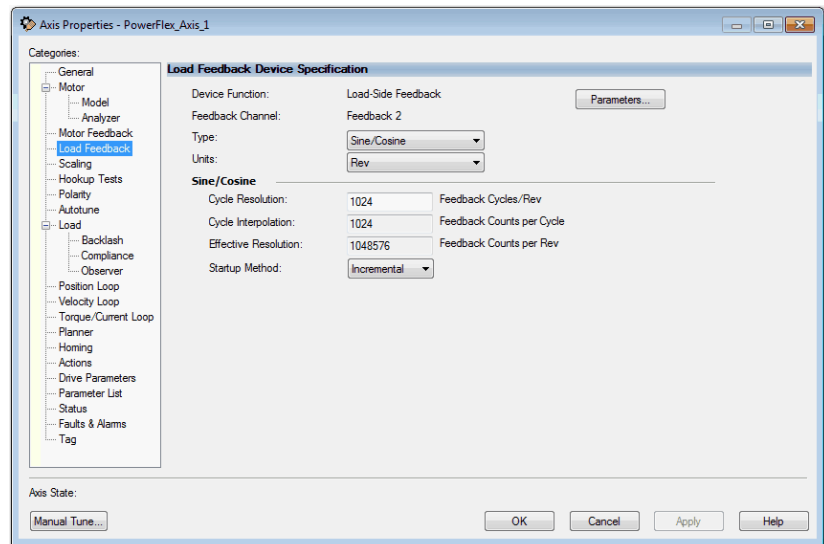
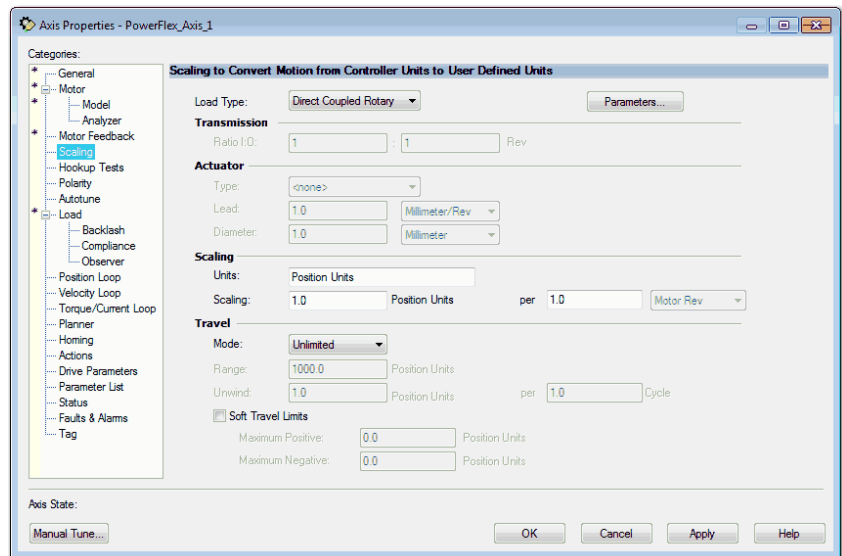

Figure 50 - Example 2: Position Loop with Dual Feedback, Scaling Dialog Box



7. From the Load Type dropdown menu, choose your load type.
8. Enter the Scaling Units.
9. From the Travel Mode dropdown menu, choose a Travel Mode.  
See [Scaling on page 119](#) for more information about Scaling.
10. Click Apply and OK to exit Axis Properties.

You are now finished configuring a PowerFlex 755 drive axis as Position Loop with Dual Feedback.

### Example 3: Velocity Loop with Motor Feedback Via a UFB Feedback Device

This example describes how to create two AXIS\_CIP\_DRIVE axes that are associated to a PowerFlex 755 drive with dual motor feedback via a universal feedback device, catalog number 20-750-UFB-1.



Remember that you already assigned the feedback device when you added the drive to your project.

1. Once you have created an AXIS\_CIP\_DRIVE, open the Axis Properties.
2. Connect the Feedback Port 1 with one feedback cable that is connected to the PowerFlex 755 drive.
3. From the Axis Configuration dropdown menu, choose Velocity Loop.
4. From the Feedback Configuration dropdown menu, choose Motor Feedback.

Figure 51 - Example 3: Velocity Loop with Motor Feedback, General Dialog Box

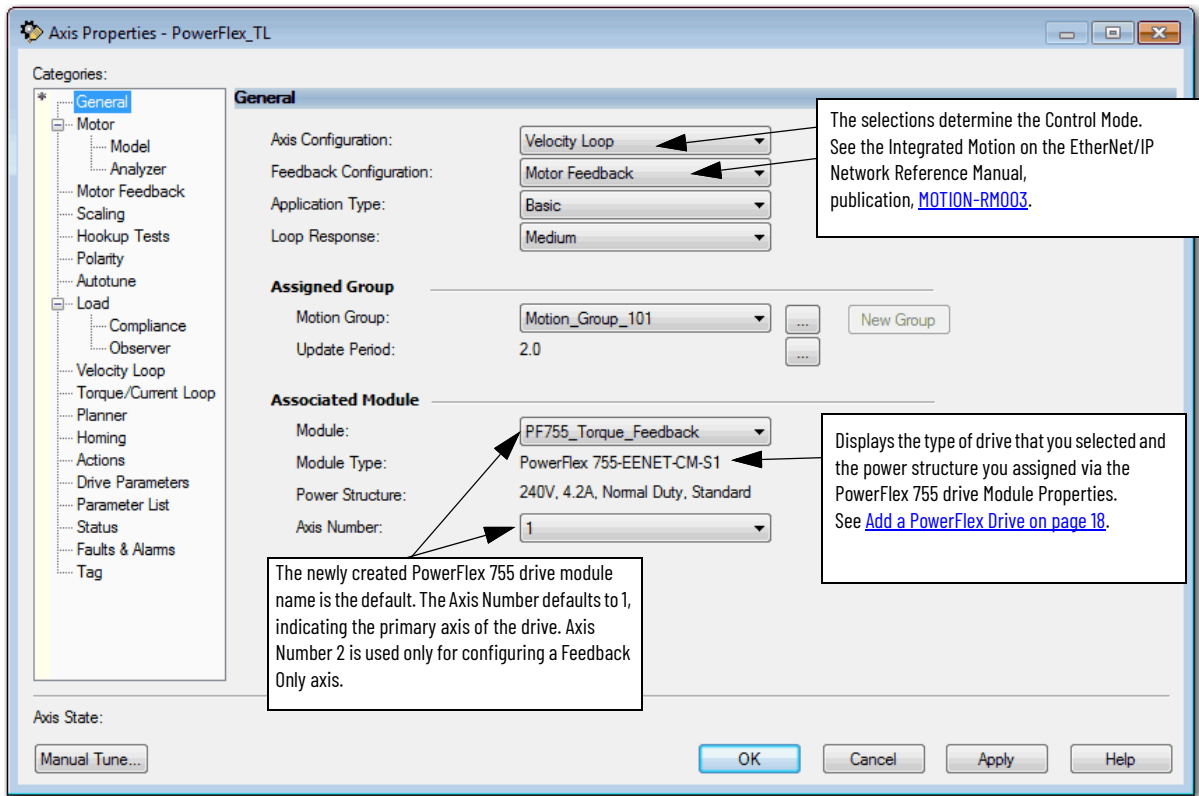

**IMPORTANT** After you have configured the axis and you change the Axis Configuration type or the Axis Number, some of the configuration information is set to default values. This change can cause some previously entered data to be reset back to its default setting.

Now that you defined the axis as a Velocity Loop with Motor Feedback, the Motor and Motor Feedback dialog boxes become available.

Figure 52 - Example 3: Velocity Loop with Motor Feedback, Motor Dialog Box

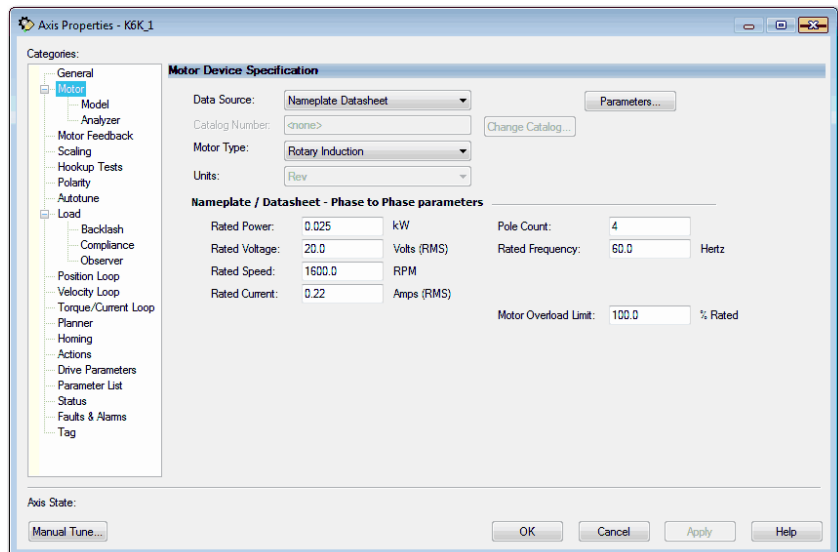

5. From the Data Source dropdown menu, choose Nameplate data sheet.
6. From the Motor Type dropdown menu, choose Rotary Induction.

7. Enter the parameters by using the information from the motor Nameplate or data sheet and click Apply.

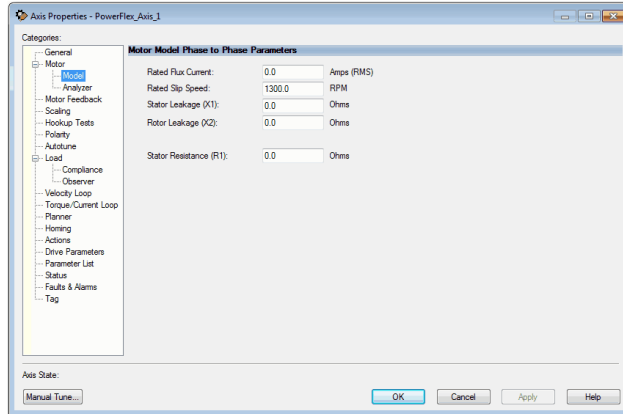

8. Enter the parameters on the Motor Model dialog box by using the information from the motor Nameplate or data sheet and click Apply.

Figure 53 - Example 3: Motor Feedback Dialog Box, Velocity Loop with Motor Feedback

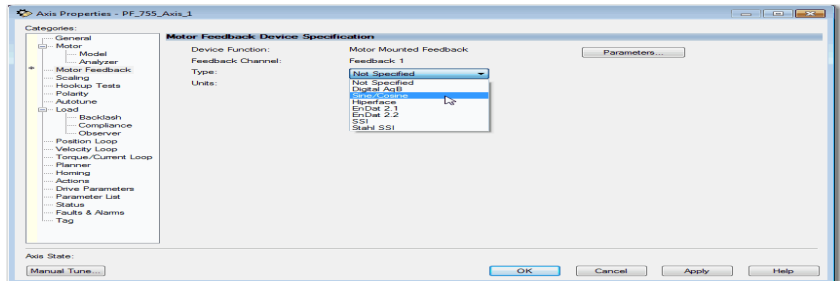

9. From the Type dropdown menu, choose the type of feedback.  
The fields are populated with the data that relates to the motor and feedback types you chose.

Figure 54 - Example 3: Velocity Loop with Motor Feedback, Motor Feedback Dialog Box

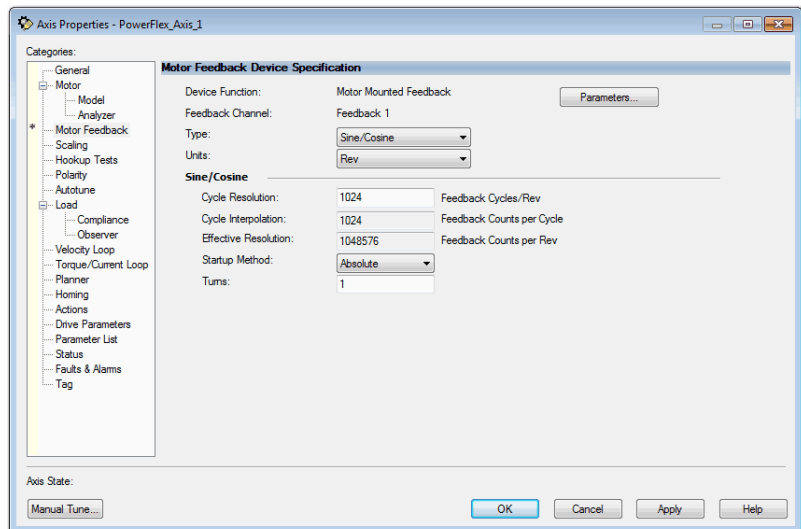

10. Click Scaling.

Figure 55 – Example 3: Velocity Loop with Motor Feedback, Scaling Dialog Box

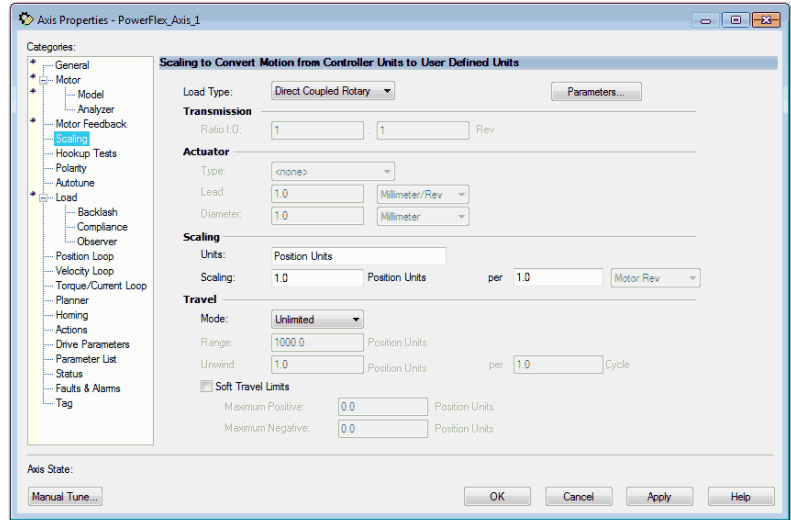

11. From the Load Type dropdown menu, choose the appropriate load type.
12. Enter the Scaling Units.
13. From the Travel Mode dropdown menu, choose the appropriate Travel Mode.  
See [Scaling on page 119](#) for more information.
14. Click Apply and OK to exit Axis Properties.

You are now finished configuring the axis as Velocity Loop with Motor Feedback.

## Example 4: Velocity Loop with No Feedback

In this example, you create an AXIS\_CIP\_DRIVE configured for a Velocity Loop with No Feedback axis and associate the axis to the PowerFlex 755 drive.

1. From the Axis Configuration dropdown menu, choose Velocity Loop.
2. From the Feedback Configuration dropdown menu, choose No Feedback.

Figure 56 - Example 4: Velocity Loop with No Feedback, General Dialog Box

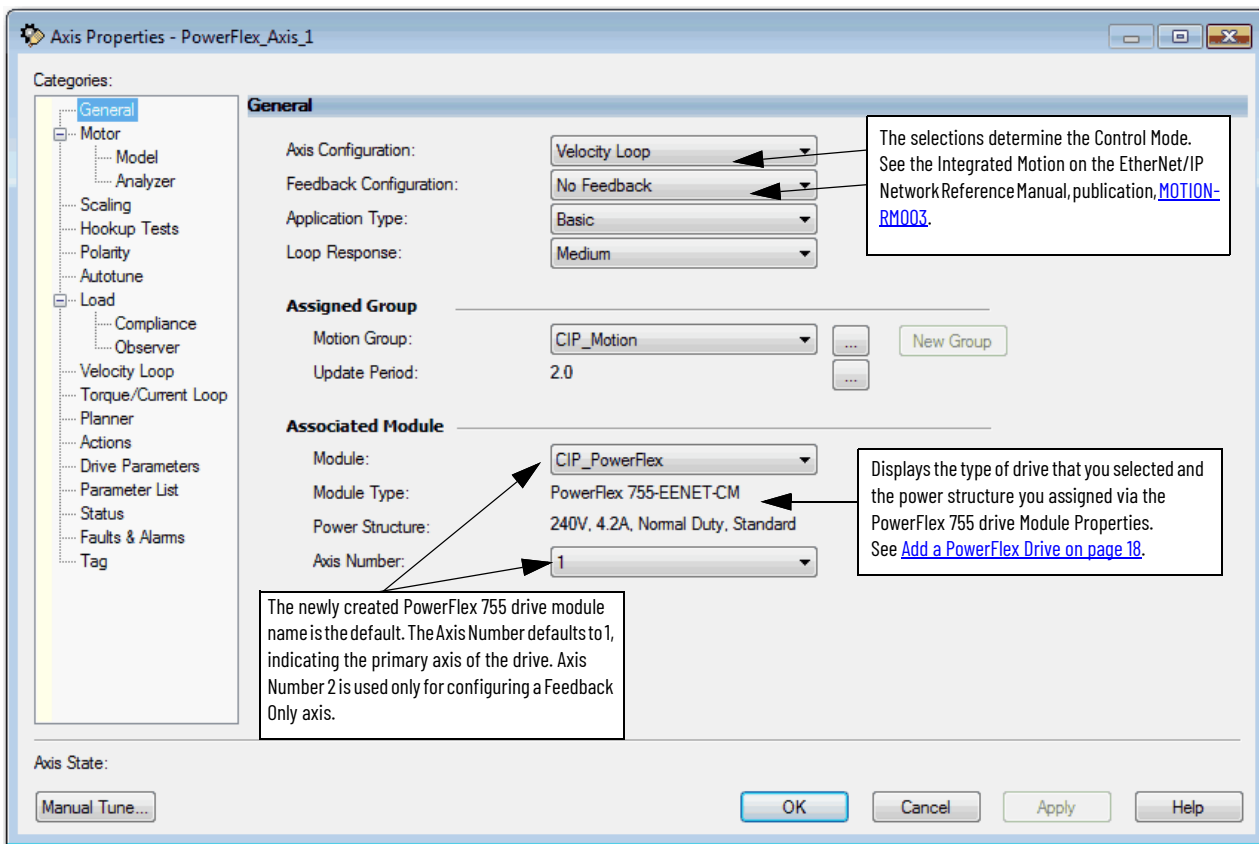

3. From the Data Source dropdown menu, choose Nameplate data sheet.

Figure 57 - Example 4: Velocity Loop with No Feedback, Motor Dialog Box

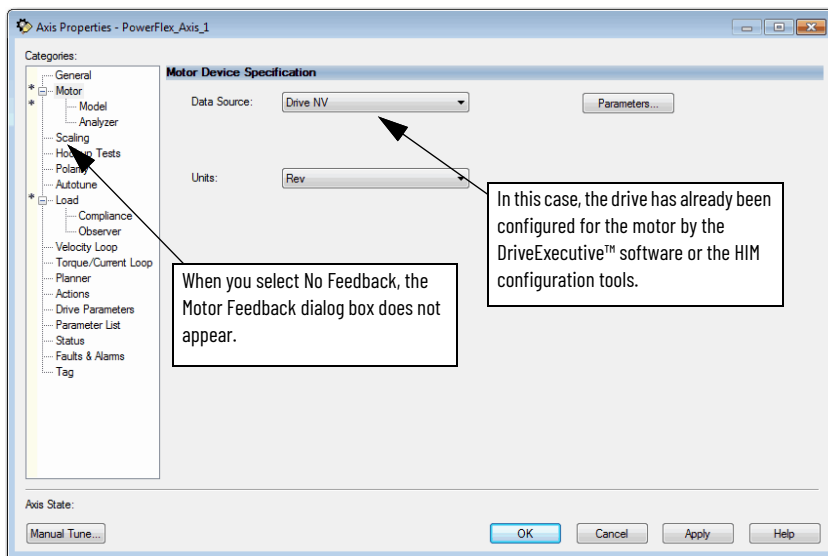
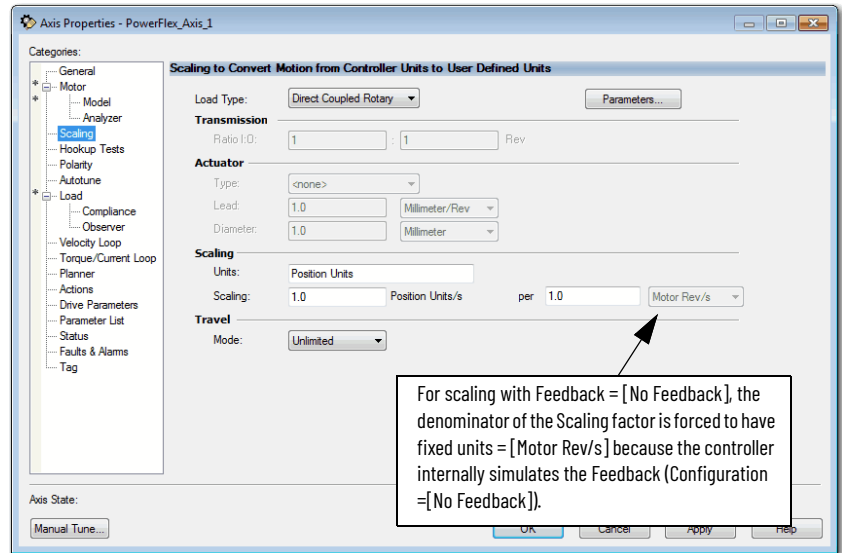
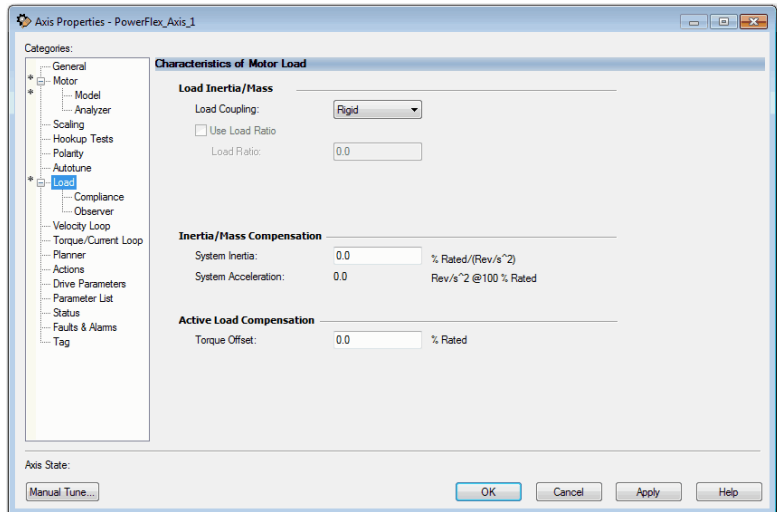

Figure 58 – Example 4: Velocity Loop with No Feedback, Scaling Dialog Box



4. From the Load Type dropdown menu, choose the appropriate load type.
5. Enter the Scaling Units.
6. From the Travel Mode dropdown menu, choose the appropriate Travel Mode.  
See [Scaling on page 119](#) for more information.
7. Click Apply.

Figure 59 – Example 4: Velocity Loop with No Feedback, Load Dialog Box



8. From the Load Coupling dropdown menu, choose the appropriate load coupling.
9. Enter the System Inertia.
10. Enter the Torque Offset, if applicable.  
For more information about the load characteristics, see [Load on page 133](#).
11. Click Apply.

You are now finished configuring an axis as Velocity Loop with No Feedback.

## Example 5: Frequency Control with No Feedback

In this example, you are configuring an axis for Frequency Control with No Feedback.

1. Once you have created the AXIS\_CIP\_DRIVE axis, open the Axis Properties.
2. From the Axis Configuration dropdown menu, choose Frequency Control.
3. From the Feedback Configuration dropdown menu, choose No Feedback.

Figure 60 – Example 5: Frequency Control with No Feedback, General Dialog Box

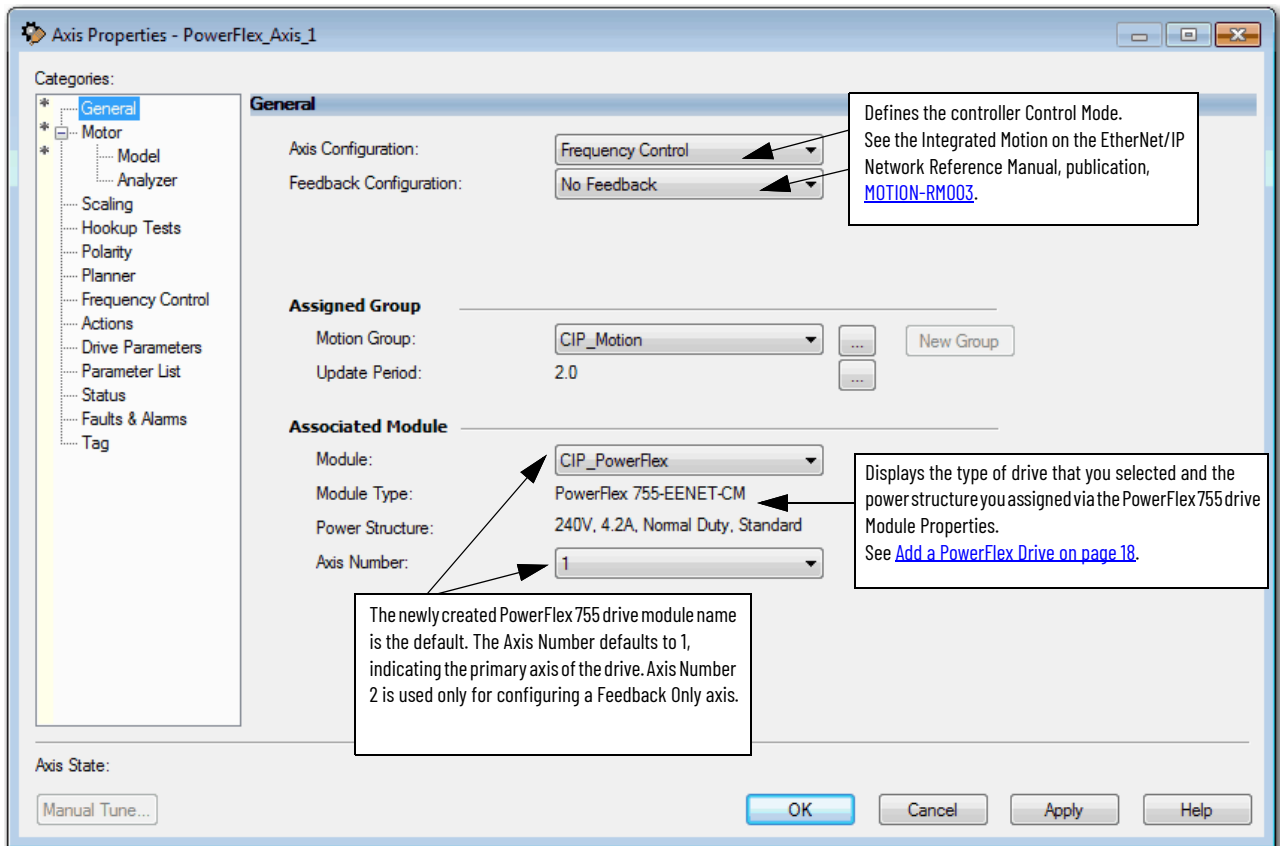

4. From the Data Source dropdown menu, choose a data source.  
In this case, Nameplate data sheet is the Data Source.  
See the [Specify the Motor Data Source on page 48](#) for more information about Data Sources.

Figure 61 – Example 5: Frequency Control with No Feedback, Motor Dialog Box

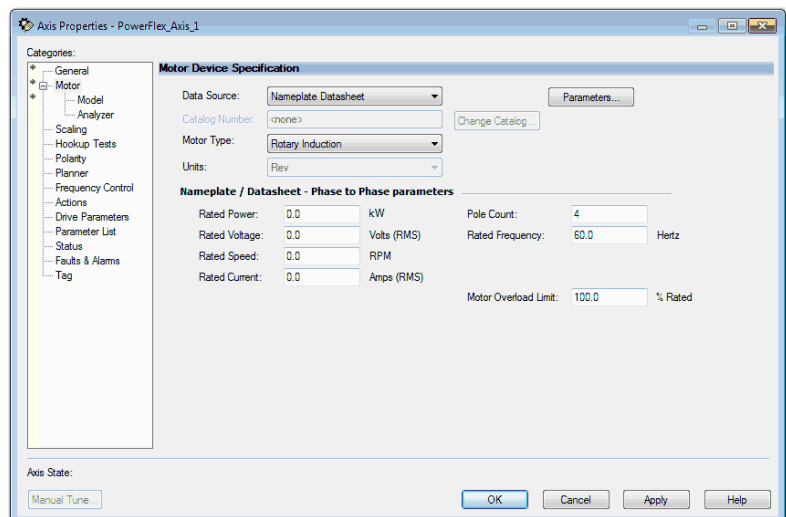

In this case, the data source is Catalog Number and the Motion Database provides values for these fields.

See the [Display Motor Model Information on page 51](#) for more information about data sources.

Figure 62 - Example 5: Frequency Control with No Feedback, Motor Model Dialog Box

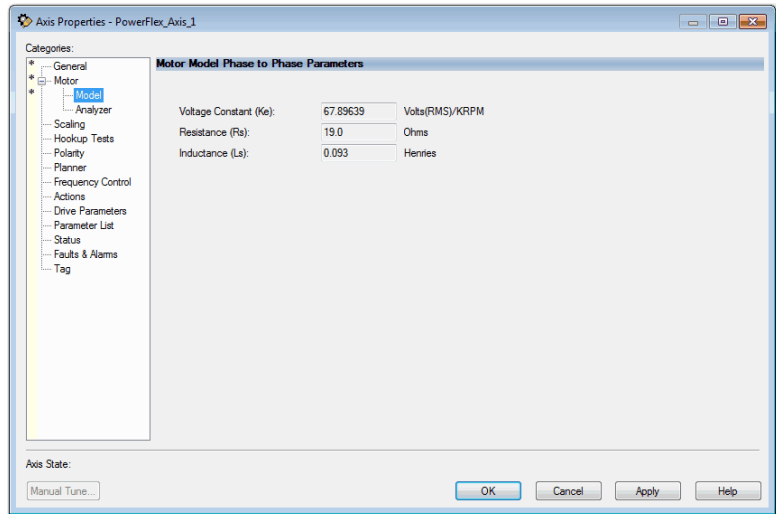

5. From the Frequency Control Method dropdown menu, choose the appropriate method.
6. Click Apply.

Figure 63 - Example 5: Frequency Control with No Feedback, Frequency Control Dialog Box

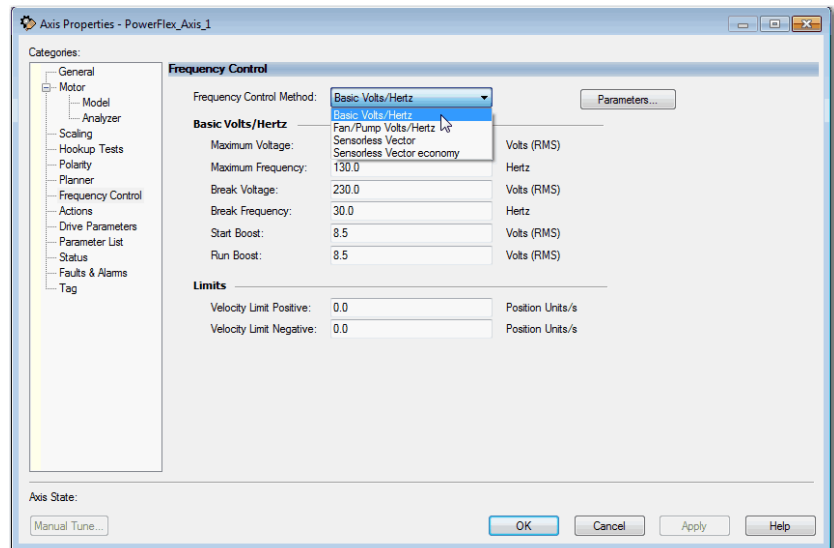

Figure 64 – Example 5: Frequency Control Method, Basic Volts/Hertz

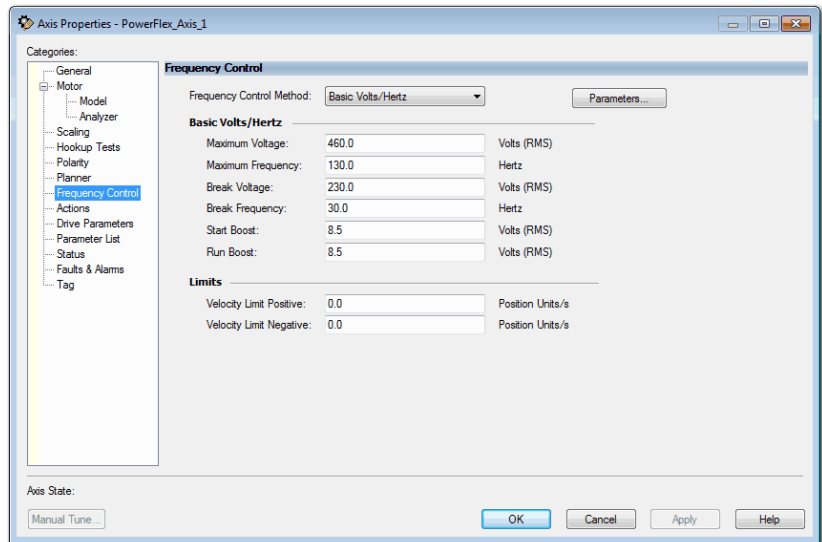
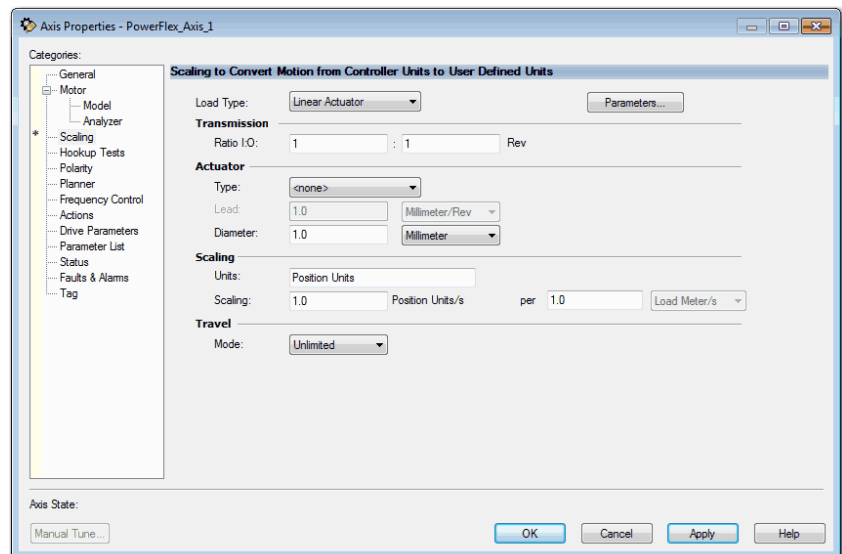

Figure 65 – Example 5: Frequency Control with No Feedback, Scaling Dialog Box Conversion Units



7. From the Load Type dropdown menu, choose the appropriate load type.
8. Enter the Transmission Ratio.
9. From the Actuator Type dropdown menu, choose the appropriate actuator.
10. Enter the Diameter dimensions.
11. Enter the Scaling Units.  
See the [Scaling on page 119](#) for more information.
12. From the Travel Mode dropdown menu, choose the appropriate travel mode.
13. Click Apply.

You are now finished configuring the axis for Frequency Control with No Feedback.

## Example 6: Torque Loop with Feedback

1. Once you have created the AXIS\_CIP\_DRIVE axis, open the Axis Properties.
2. From the Axis Configuration dropdown menu, choose Torque Loop.
3. From the Feedback Configuration dropdown menu, choose Motor Feedback.

Figure 66 - Example 6: Torque Loop with Motor Feedback, General Dialog Box

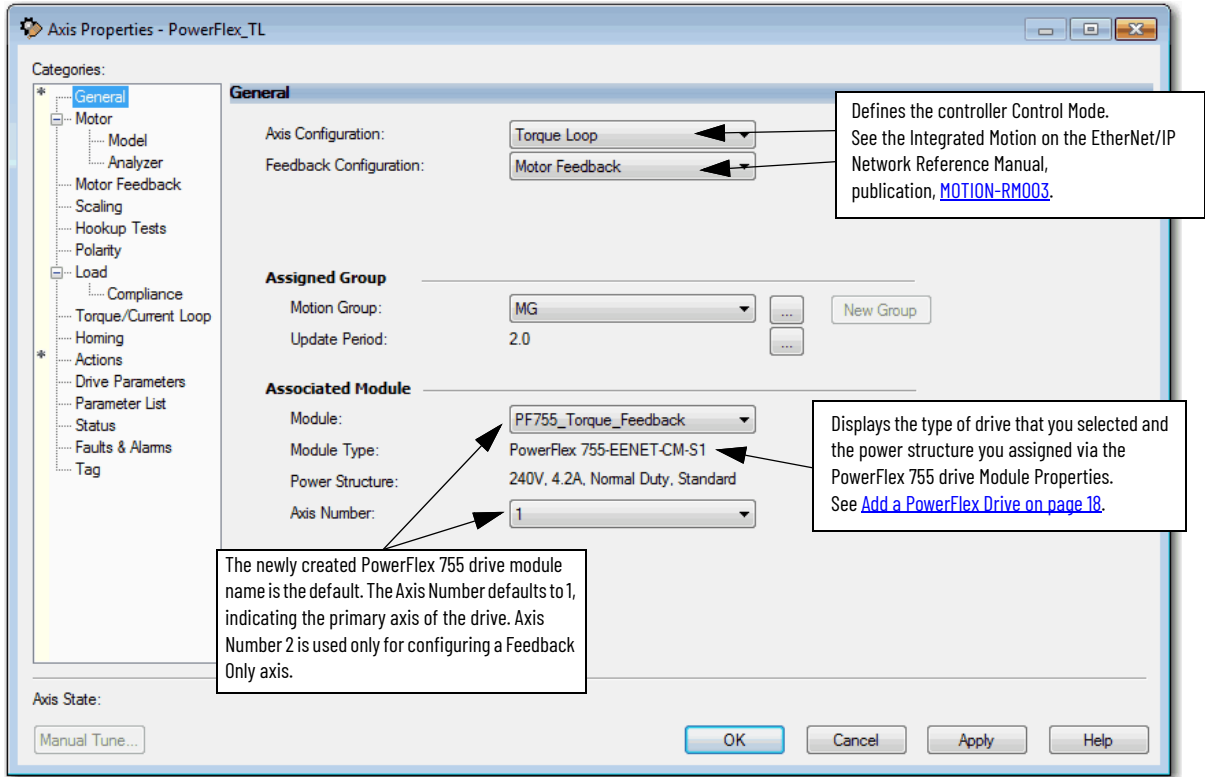

Figure 67 - Example 6: Torque Loop with Motor Feedback, Motor Dialog Box

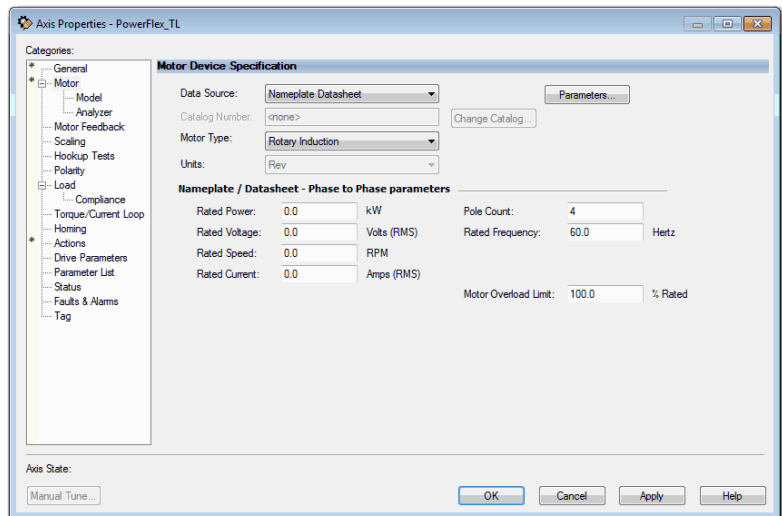
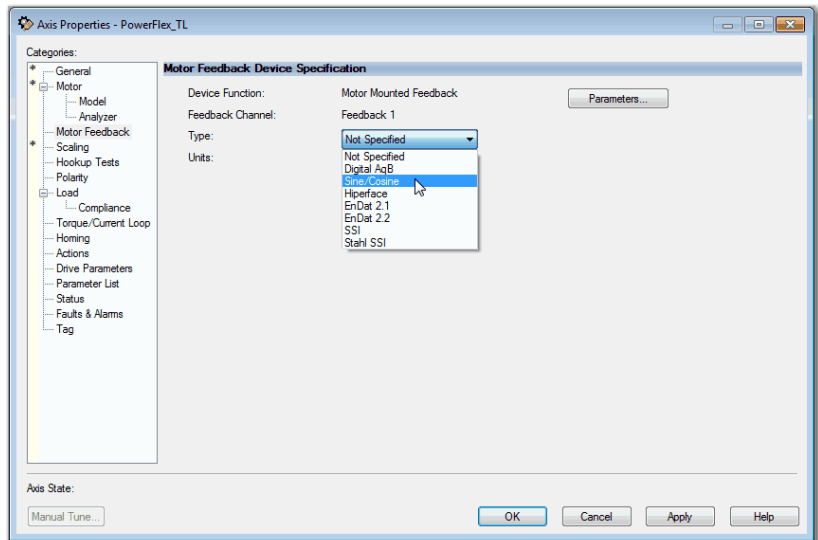

Figure 68 - Example 6: Torque Loop with Motor Feedback, Feedback Type



4. From the Type dropdown menu, choose the appropriate feedback type.

Figure 69 - Example 6: Torque Loop with Motor Feedback, Feedback Type

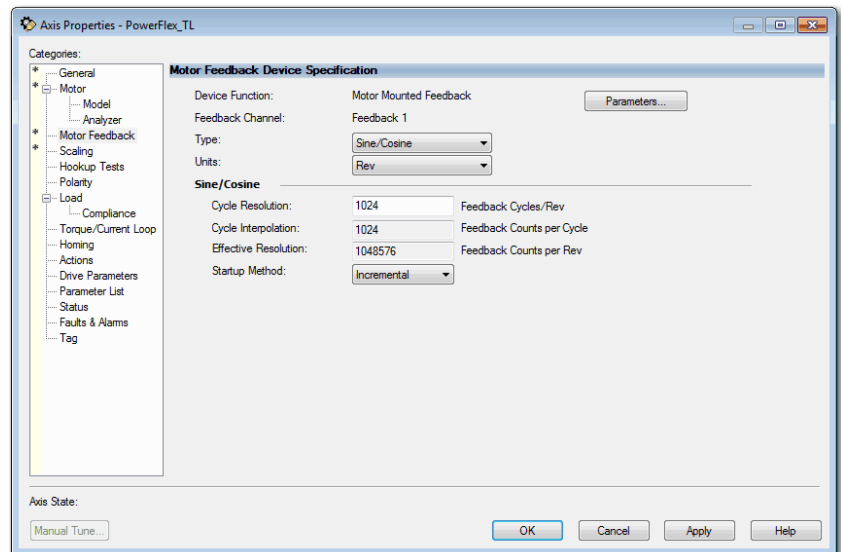
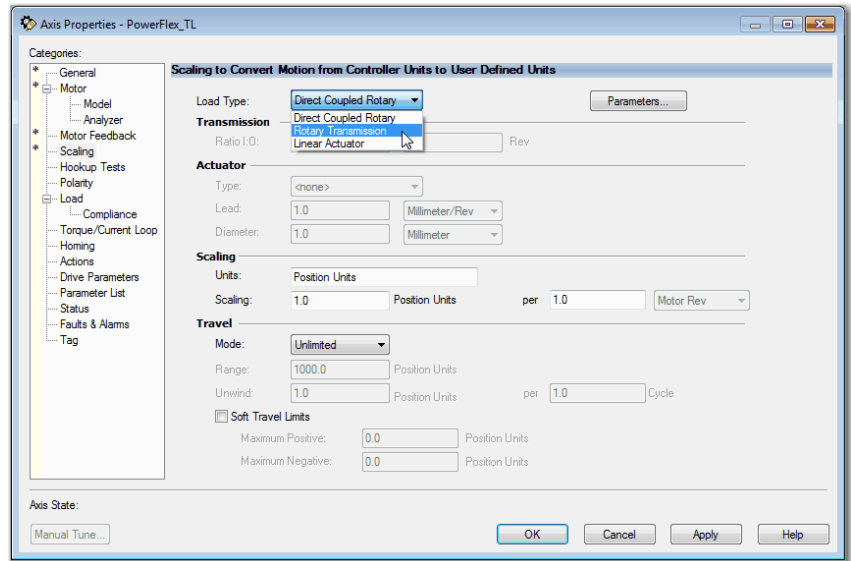
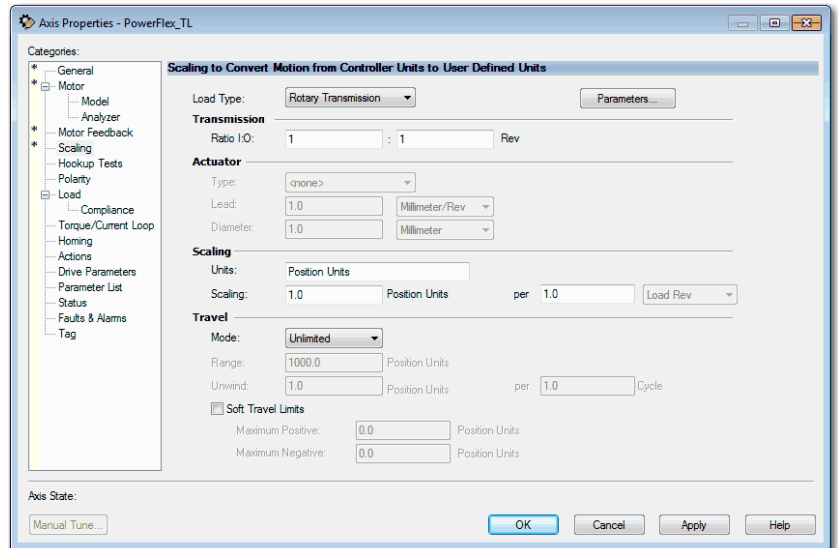

Figure 70 - Example 6: Torque Loop with Motor Feedback, Scaling Load Type



- From the Load Type dropdown menu, choose the appropriate load type.

Figure 71 - Example 6: Torque Loop with Motor Feedback, Scaling Conversions



- Enter the Transmission Ratio.
- Enter the Scaling Units.
- From the Travel Mode dropdown menu, choose the appropriate travel mode. See the [Scaling on page 119](#) for more information.
- Click Apply.

You are now finished configuring the axis for Torque Loop with Motor Feedback.

## Axis Configuration Examples for the PowerFlex 527 Drive

This chapter provides example axis configurations when using a PowerFlex® 527 drive.

The following examples are typical axis-configuration applications for the PowerFlex 527 drive:

- Frequency Control with No Feedback
- Velocity Control with Motor Feedback
- Position Control with Motor Feedback

### Example 1: Frequency Control with No Feedback

The PowerFlex 527 drives support basic Volts/Hertz (V/Hz), Fan/Pump Volts/ Hertz, Sensorless Vector Control (SVC), and Sensorless Vector Control (SVC) Economy frequency control methods.

Follow these steps to configure the induction motor axis properties.

1. In the Controller Organizer, right-click an axis and choose Properties.
2. Select the General category.

The General and Associated Module dialog box appears.

**Figure 72 - Example 1: Frequency Control with No Feedback, General Dialog Box**

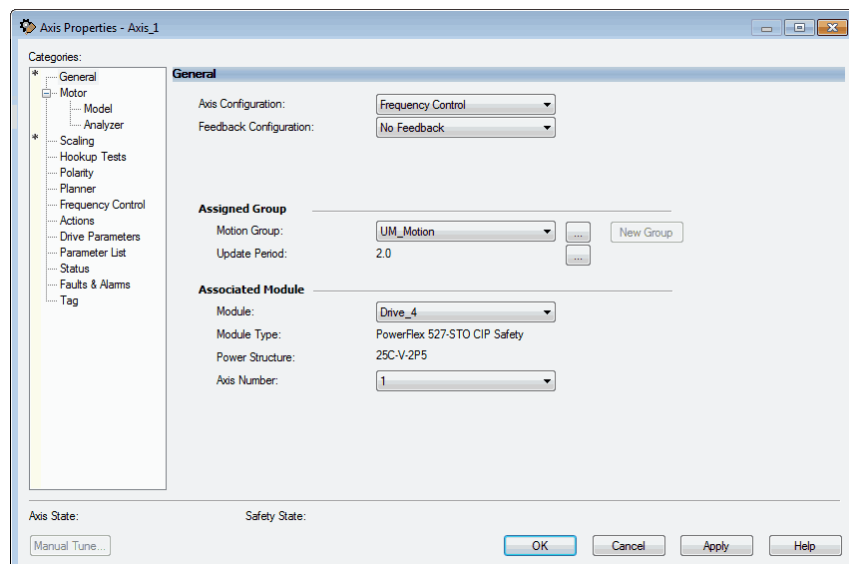

3. From the Axis Configuration dropdown menu, choose Frequency Control.
4. From the Module dropdown menu, your PowerFlex 527 drive.  
The Module Type and Power Structure fields populate with the chosen drive catalog number.
5. Click Apply.
6. Select the Motor category.  
The Motor Device Specification dialog box appears.

Figure 73 - Example 1: Frequency Control with No Feedback, Motor Device Specification Dialog Box

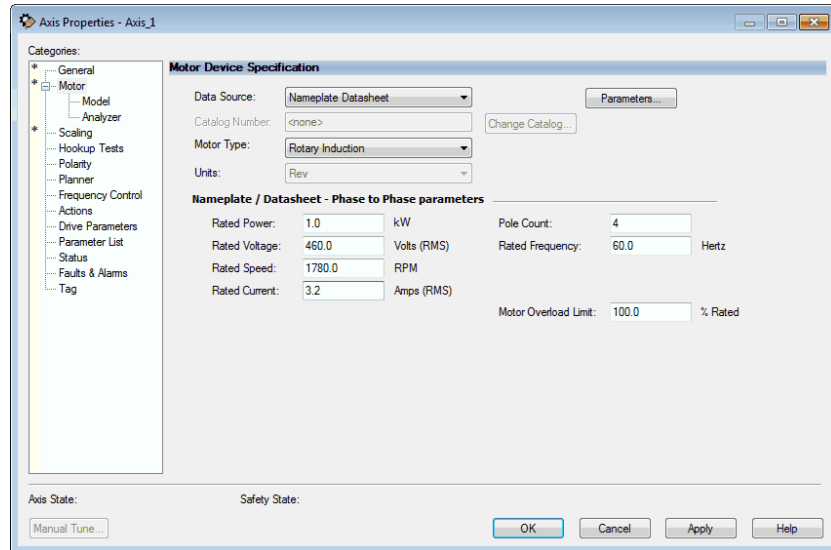

7. From the Data Source dropdown menu, choose Nameplate data sheet. This selection is the default setting.
8. From the Motor Type dropdown menu, choose Rotary Induction.
9. From the motor nameplate or data sheet, enter the phase-to-phase values.
10. Click Apply.
11. Select the Frequency Control category. The Frequency Control dialog box appears.

Figure 74 - Example 1: Frequency Control with No Feedback, Frequency Control Dialog Box

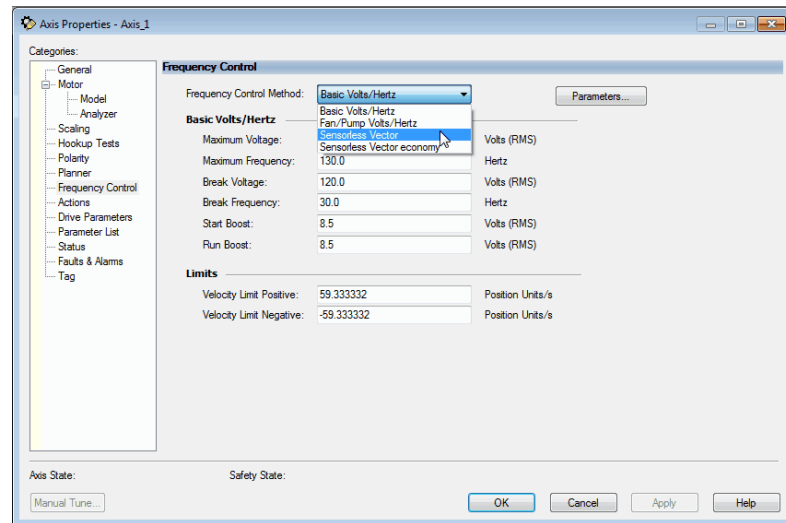

12. From the Frequency Control Method dropdown menu, choose the method appropriate for your application.
13. If you chose the Basic Volts/Hertz method, enter the nameplate data for your motor in the Basic Volts/Hertz fields. If you chose the Sensorless Vector method, the Basic Volts/Hertz fields are dimmed.
14. Click Apply.
15. If you chose the Sensorless Vector or Sensorless Vector Economy method, select the Motor > Analyzer category. The Analyze Motor to Determine Motor Model dialog box appears.

**Figure 75 – Example 1: Frequency Control with No Feedback, Analyze Motor to Determine Motor Model Dialog Box**

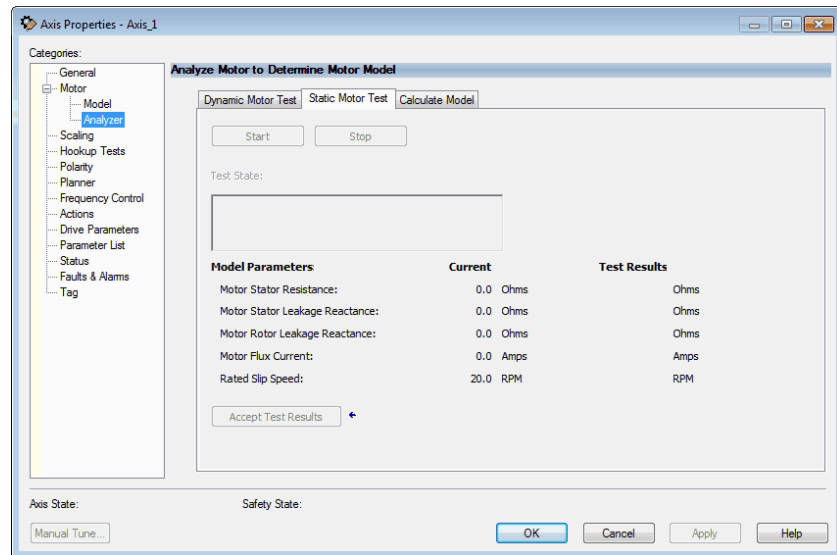

16. Click the Static Motor Test tab.
17. To run the test and measure Motor Stator Resistance, click Start.  
If you choose the Basic Volts/Hertz category, you can skip this test.  
Some out-of-box settings must be applied here. See [Appendix C](#) for more information.
18. Select the Actions category.  
The Actions to Take Upon Conditions dialog box appears.

**Figure 76 – Example 1: Frequency Control with No Feedback, Actions to Take Upon Conditions Dialog Box**

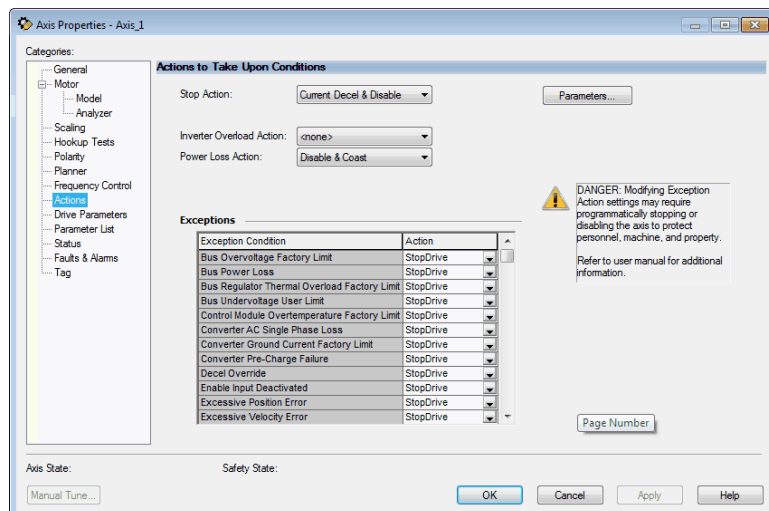

From this dialog box, you can program actions and change the action for exceptions (faults). See the PowerFlex 527 Adjustable Frequency AC Drive User Manual, publication [520-UM002](#) for more information.

Some out-of-box settings must be applied here. See [Appendix C](#) for more information.

19. Select the Parameter List category.  
The Motion Axis Parameters dialog box appears.

Figure 77 - Example 1: Frequency Control with No Feedback, Motion Axis Parameters Dialog Box

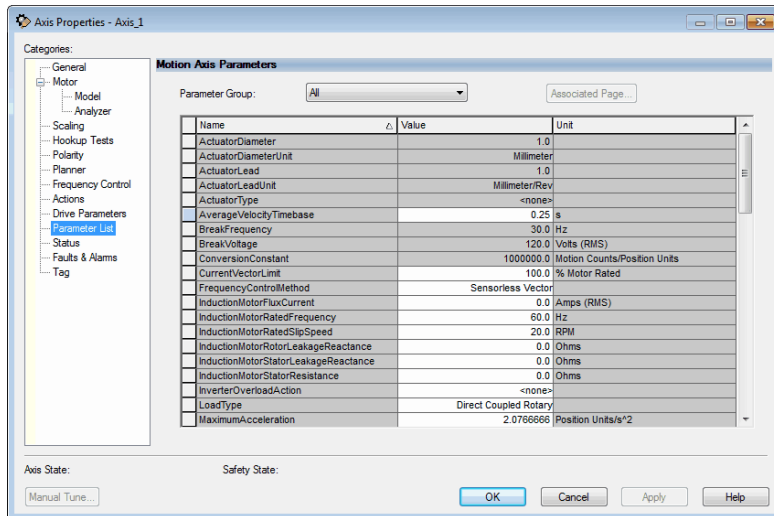

From this dialog box, you can program actions and change the action for exceptions (faults). See the PowerFlex 527 Adjustable Frequency AC Drive User Manual, publication [520-UM002](#) for more information.

To obtain the best performance from the drive, regardless of which control method you are using, configure the recommended out-of-box settings. These settings are described in [Appendix C](#).

20. Click OK.
21. Repeat steps 1...20 for each induction motor axis.

## Example 2: Velocity Control with Motor Feedback

Follow these steps to configure the induction motor axis properties.

1. In the Controller Organizer, right-click an axis and choose Properties.
  2. Select the General category.
- The General and Associated Module dialog box appears.

Figure 78 - Example 2: Velocity Control with Motor Feedback, General Dialog Box

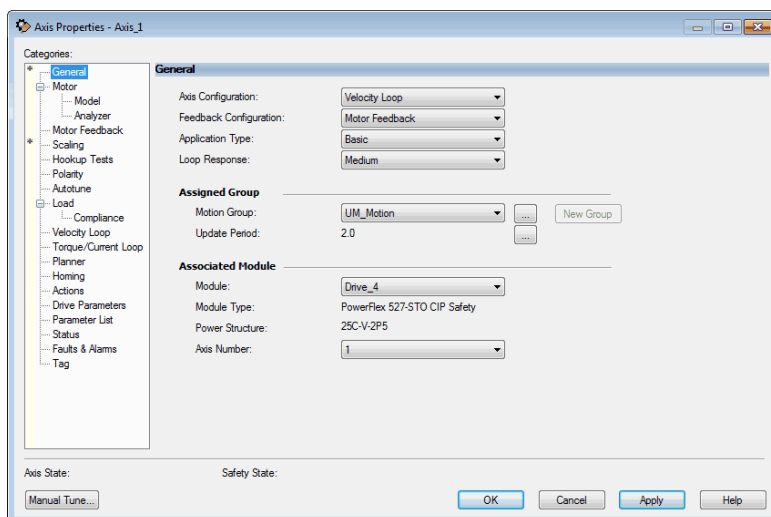

3. From the Axis Configuration dropdown menu, choose Velocity Loop.
4. From the Module dropdown menu, your PowerFlex 527 drive.  
The Module Type and Power Structure fields populate with the chosen drive catalog number.
5. Click Apply.
6. Select the Motor category.

The Motor Device Specification dialog box appears.

Figure 79 – Example 2: Velocity Control with Motor Feedback, Motor Device Specification Dialog Box

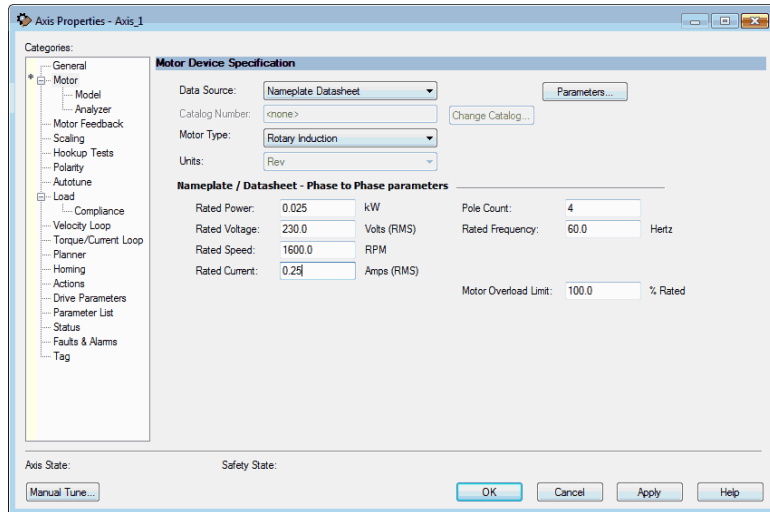

7. From the Data Source dropdown menu, choose Nameplate data sheet. This selection is the default setting.
8. From the Motor Type dropdown menu, choose Rotary Induction.
9. From the motor nameplate or data sheet, enter the phase-to-phase values.
10. Click Apply.
11. Select the Motor Feedback category.

Figure 80 – Example 2: Velocity Control with Motor Feedback, Motor Feedback Device Specification Dialog Box

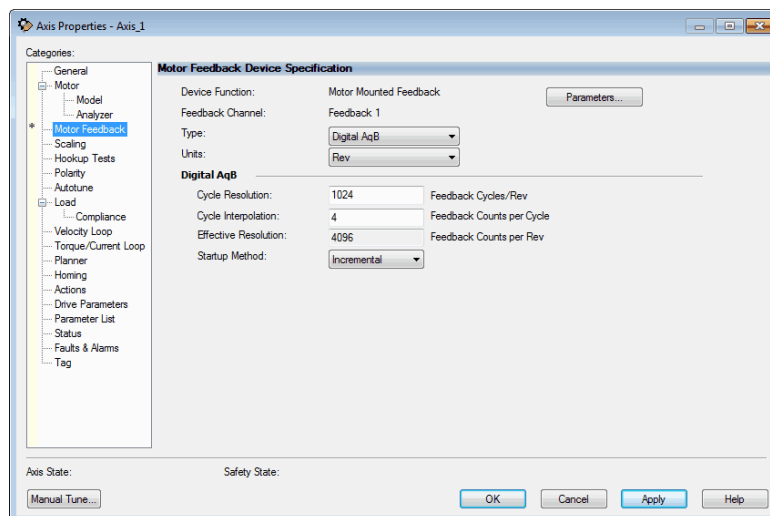

12. Enter the specifications of your encoder into the fields.
13. Click Apply.
14. Select the Scaling category and edit the values as appropriate for your application.
15. If you changed any settings, click Apply.
16. Select the Actions category.

The Actions to Take Upon Conditions dialog box appears.

From this dialog box, you can program actions and change the action for exceptions (faults). Some out-of-box (OOB) settings must be applied here. See [Appendix C](#) on [page 221](#) for more information.

17. Select the Parameter List category.

The Motion Axis Parameters dialog box appears.

Figure 81 - Example 2: Velocity Control with Motor Feedback, Motion Axis Parameters Dialog Box

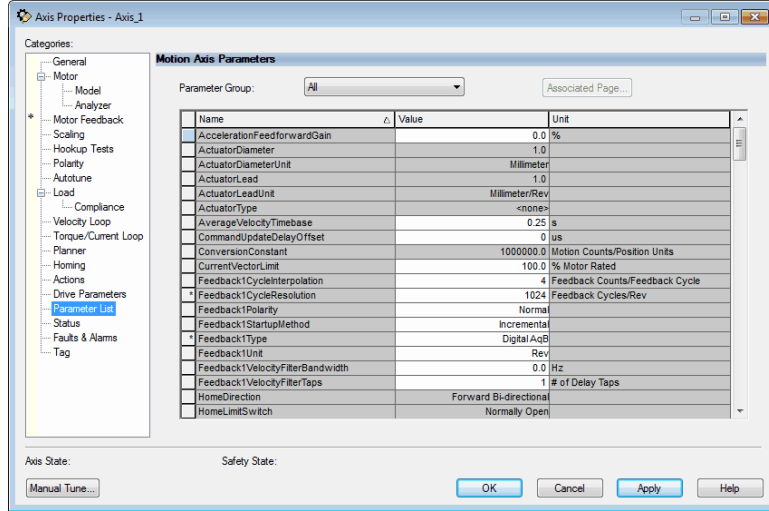

From this dialog box, you can program actions and change the action for exceptions (faults). See the PowerFlex 527 Adjustable Frequency AC Drive User Manual, publication [520-UM002](#) for more information.

To obtain the best performance from the drive, regardless of which control method you are using, configure the recommended out-of-box settings. These settings are described in the PowerFlex 527 Adjustable Frequency AC Drive User Manual, publication [520-UM002](#).

18. Click OK.
19. Repeat steps 1...18 for each induction motor axis.

### Example 3: Position Control with Motor Feedback

Follow these steps to configure the induction motor axis properties.

1. In the Controller Organizer, right-click an axis and choose Properties.
2. Select the General category.

The General and Associated Module dialog box appears.

Figure 82 - Example 3: Position Control with Motor Feedback, General Dialog Box

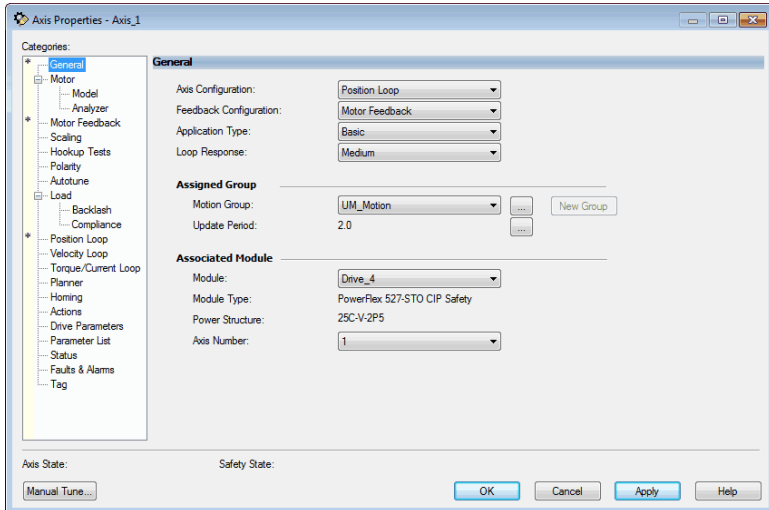

3. From the Axis Configuration dropdown menu, choose Position Loop.
4. From the Module dropdown menu, your PowerFlex 527 drive.  
The Module Type and Power Structure fields populate with the chosen drive catalog number.
5. Click Apply.

6. Select the Motor category.  
The Motor Device Specification dialog box appears.

**Figure 83 – Example 3: Position Control with Motor Feedback, Motor Device Specification Dialog Box**

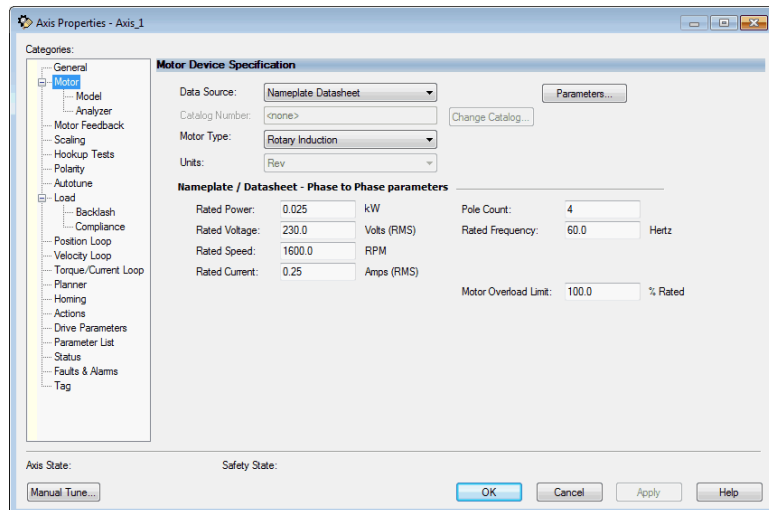

7. From the Data Source dropdown menu, choose Nameplate data sheet.  
This selection is the default setting.
8. From the Motor Type dropdown menu, choose Rotary Induction.
9. From the motor nameplate or data sheet, enter the phase-to-phase values.
10. Click Apply.
11. Select the Motor Feedback category.

**Figure 84 – Example 3: Position Control with Motor Feedback, Motor Feedback Device Specification Dialog Box**

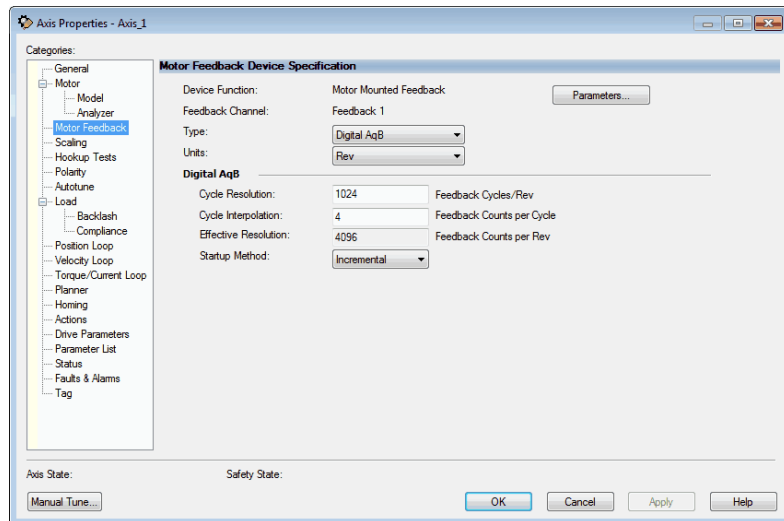

12. Enter the specifications of your encoder into the fields.
13. Click Apply.
14. Select the Scaling category and edit the values as appropriate for your application.

Figure 85 – Example 3: Position Control with Motor Feedback, Scaling to Convert Motion from Controller Units to User-defined Units Dialog Box

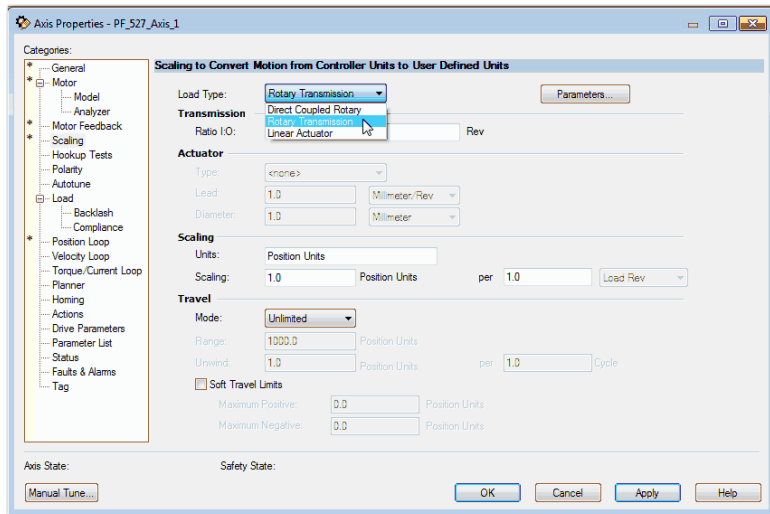

15. If you changed any settings, click Apply.
16. Select the Actions category.  
The Actions to Take Upon Conditions dialog box appears.

Figure 86 – Example 3: Position Control with Motor Feedback, Actions to Take Upon Conditions Dialog Box

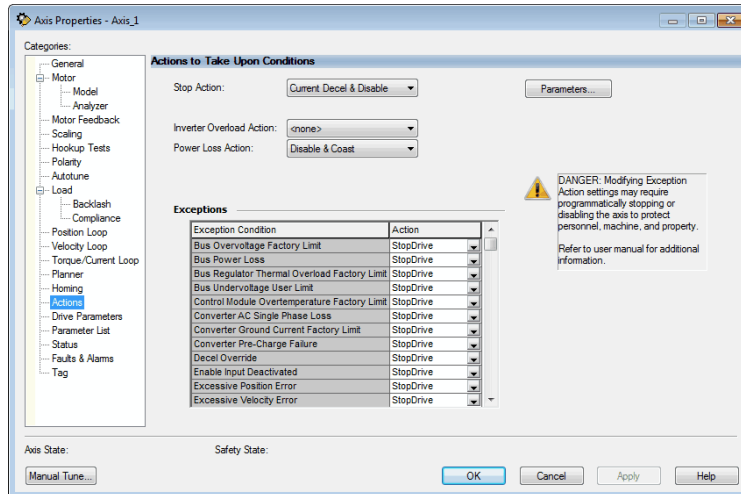

- From this dialog box, you can program actions and change the action for exceptions(faults). Some out-of-box(OOB)settings must be applied here. See [Appendix C](#) for more information.
17. Select the Parameter List category.  
The Motion Axis Parameters dialog box appears.

Figure 87 - Example 3: Position Control with Motor Feedback, Motion Axis Parameters Dialog Box

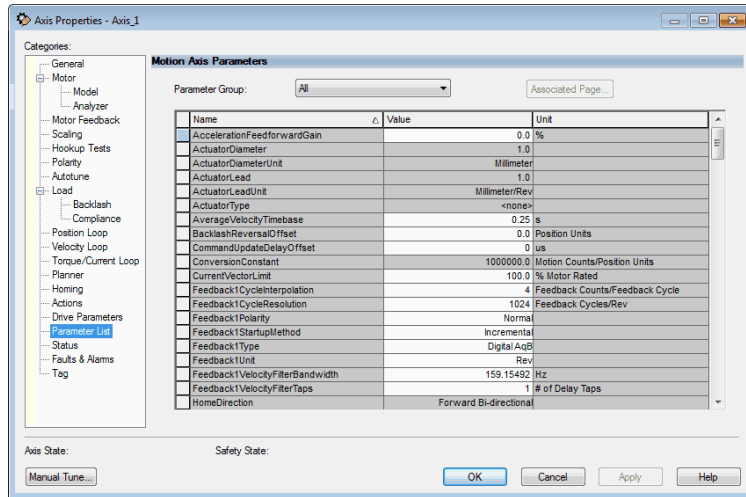

From this dialog box, you can program actions and change the action for exceptions (faults).

To obtain the best performance from the drive, regardless of which control method you are using, configure the recommended out-of-box settings. These settings are described in [Appendix C](#) on [page 221](#).

18. Click OK.
19. Repeat steps [1...18](#) for each induction motor axis.

**Notes:**

## Commission an Axis

Commission the axis after you have followed the steps in these sections:

**Table 34 - Configure Drive and Axis Properties**

Section	Page
Configure Drive Properties	15
Configure Axis Properties	37

To commission the axis of your device, you must go through scaling, hookup tests, polarity, autotune, and load, which are all discussed in this chapter.

### Scaling

Axis motion can be specified in whatever units you want. In the Scaling dialog box, you configure the motion control system to convert between raw internal-motion units. For example, Feedback Counts or Planner Counts can be converted to your preferred unit of measure, be it revolutions, degrees, meters, or inches.

This conversion involves three key Scaling Factor attributes, Conversion Constant, Motion Resolution, and Position Unwind. If you use the Scaling dialog box, the software calculates the Scaling Factors for you. The only task that you do is select the Load Type that best matches the mechanical linkage between the motor and the load.

There are four Load types:

- Direct Coupled Rotary
  - The load is directly coupled to the linear motor moving mass.
- Direct Coupled Linear
  - The load is directly coupled to the linear motor moving mass.
- Rotary Transmission
  - The rotational load is coupled to the motor through a geared transmission.
- Linear Actuator
  - The linear load is coupled to a rotary motor through a rotary to linear mechanical system.

This figure shows the default Scaling dialog box for a Direct Coupled Rotary load type. By default, the Scaling dialog box is set for 1 'Position Unit' per Motor Rev.

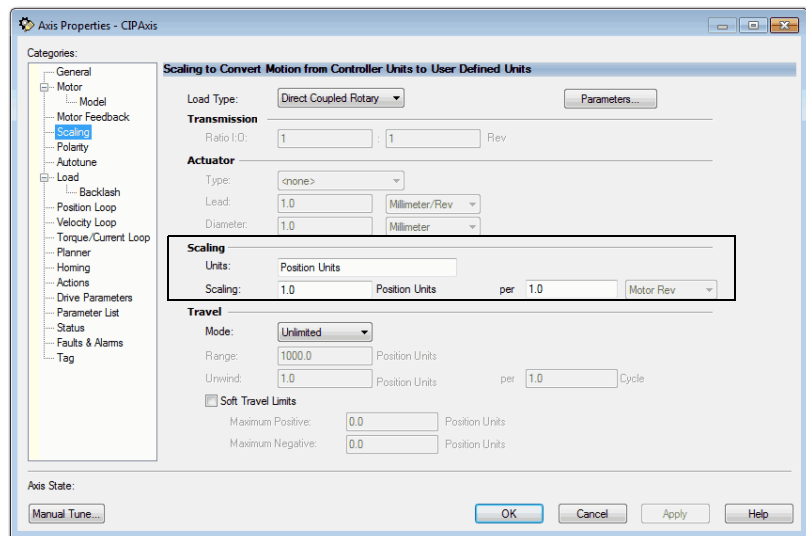

When you click Parameters, you see values for the Conversion Constant and the Motion Resolution, each having a value of 1 million. These values are generated from the software calculator.

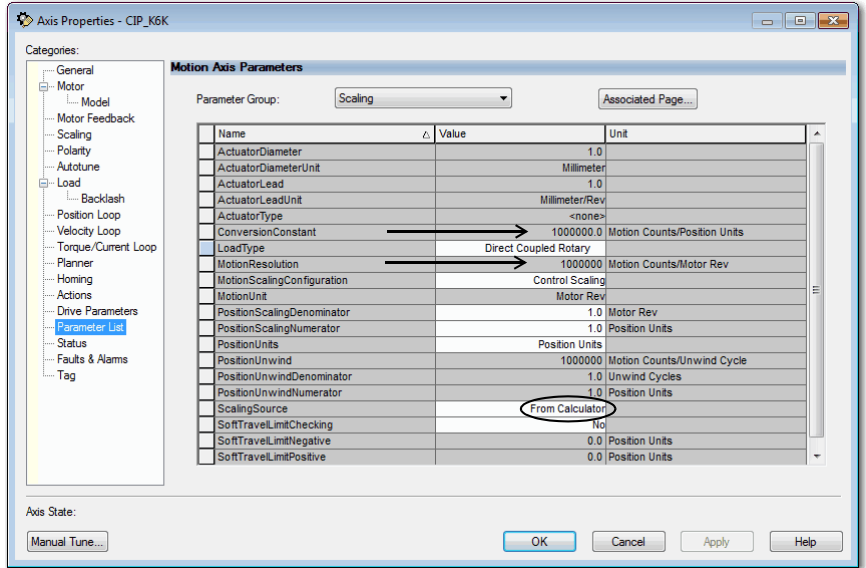

In most cases, the software scaling calculator generates Scaling Factor values that are suitable for the application. But in rare cases, like applications that require online product recipe changes, you can set the Scaling Source attribute to Direct Scaling Factor Entry. This attribute allows you to enter the Scaling Factors.

### Direct Coupled Rotary

For a Direct Coupled Rotary load type, you can express Scaling Units for the rotary motor, for example, Degrees.

Here is an example of a Direct Coupled Rotary load that is scaled in Degrees and the resulting values for the Conversion Constant and Motion Resolution.

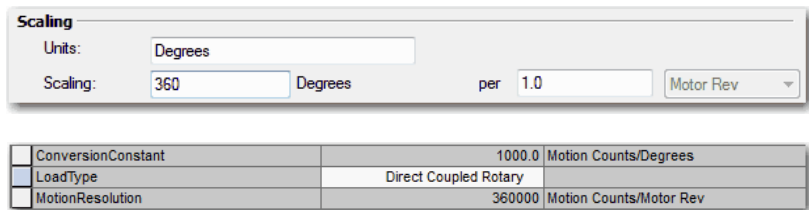

### Direct Coupled Linear

For a Direct Coupled Linear load type, you can express Scaling Units for the linear motor, for example, Inches.

Here is an example of a Direct Coupled Linear load that is scaled in Inches and the resulting values for the Conversion Constant and Motion Resolution.

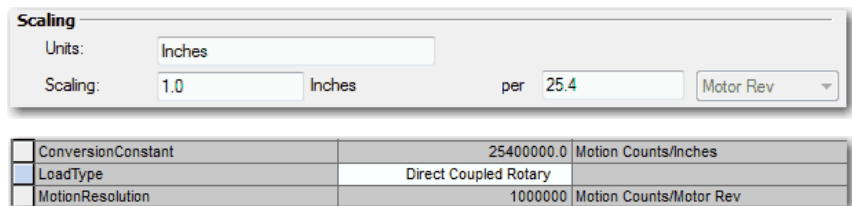

For more information about Conversion Constant and Motion Resolution, see the Integrated Motion on the EtherNet/IP Network Reference Manual, publication [MOTION-RM003](#).

## Rotary Transmission

For a Rotary Transmission load type, you enter the Transmission ratio mechanical system. When you allow the software scaling calculator to compute the Scaling Factors by using the Transmission Ratio, it reduces the risks of cumulative errors due to irrational numbers.

Here is an example of a Rotary Transmission load that is scaled in Packages (three packages per Load Revolution) and the resulting values for the Conversion Constant and Motion Resolution.

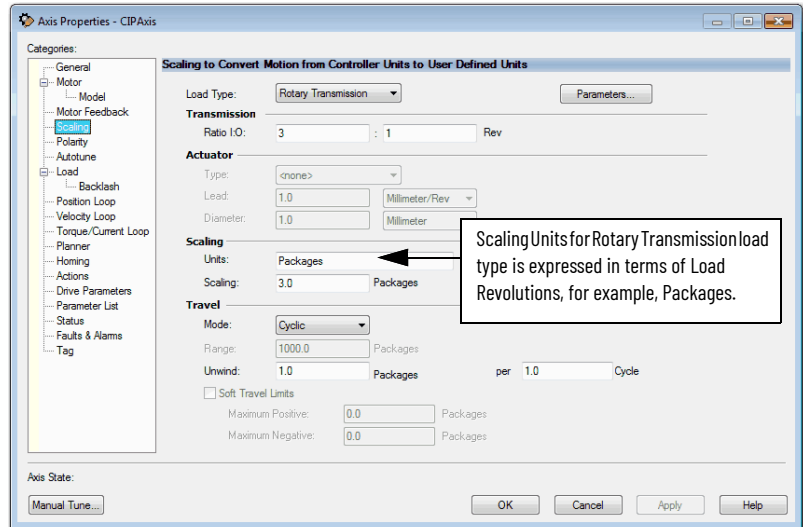

ConversionConstant	100000.0	Motion Counts/Packages
LoadType	Rotary Transmission	
MotionResolution	300000	Motion Counts/Load Rev

## Linear Actuator

With the Linear Actuator load type, you can specify the characteristics of the linear actuator mechanics by the Actuator Type.

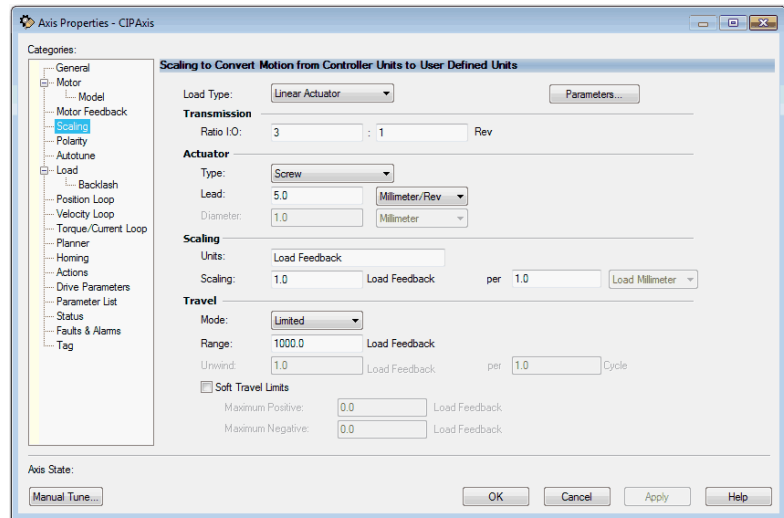

ConversionConstant	10000.0	Motion Counts/Load Feedback
LoadType	Linear Actuator	
MotionResolution	10000	Motion Counts/Load Millimeter

## Changing Scaling Factors

Changing Scaling configuration factors can have a significant impact on the calculations of factory defaults for scaling dependent-axis configuration attributes.

If you change a scaling factor that impacts other attributes, the following dialog box appears when you apply the change.

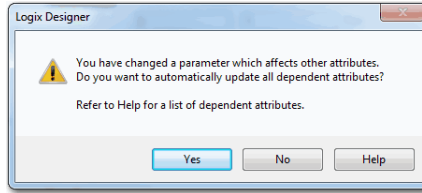

This dialog box gives you the choice to recalculate factory defaults for scaling dependent attributes.

1. To recalculate and apply all dependent attribute values, click Yes.
2. To apply only changes to the scaling attributes, click No.

Once you have applied your configurations, the factory defaults for dynamic configuration attributes, for example, gain, limits, and filter settings are automatically computed. The calculations are based on your drive and motor configuration settings and selection for application type and loop response.

The factory defaults yield a stable operational system that can then be tailored to the specific requirements for many types of machine applications.

You can use Autotune to improve performance if the gain set provided to you by the factory defaults does not satisfy the configuration requirements of your system.

See [Autotune on page 131](#).

## Hookup Tests

Use the Hookup Tests dialog box to perform the following:

- Check your cabling
- Adjust motor and feedback polarity
- Establish your sense of positive motion direction
- If applicable, check the encoder marker and commutation function

To run any of the Hookup Tests, you must first download your program.



**ATTENTION:** These tests can actively move the axis even with the controller in remote Program mode:

- Before you do the tests, make sure no one is in the way of the axis.
- Changing motor or feedback after performing the Hookup Test can result in an axis-runaway condition when the drive is enabled.

To avoid personal injury or damage to equipment, you must remove the load from each axis as uncontrolled motion can occur when an axis with an integral motor brake is released during the test.

The type of drive and the combination of the Axis and Feedback configuration types you choose determine what Hookup tests are available.



**ATTENTION:** Test Mode Enabled axes cannot perform Motor, Motor Feedback, Inertia, or Hookup Tests.

Test Mode Enabled axes return an error code "Test Prohibited - Axis Test Mode Active (value 128)."

Executing a hookup test on an axis with Test Mode enabled results in an error response. This axis also fails the MRAT or MRHD motion instruction.

**Table 35 - Types of Hookup Tests**

Test	Description
Marker	Checks that the drive gets the marker pulse. You must manually move the axis for this test.
Motor and Feedback	Tests the polarity of the motor, motion, load, and motor feedback.
Motor Feedback	Tests the polarity of the motor feedback.
Load Feedback	Test the load feedback polarity of the motor.
Commutation	Tests the commutation offset and polarity of a drive.
Master Feedback	Test the master feedback polarity.

[Table 36](#) lists the Hookup Tests that is based on axis configuration and drive type.

**Table 36 - Types of Hookup Tests**

Axis Type	Feedback Type	Drive <sup>(1)</sup>	Master Feedback	Motor and Feedback	Motor Feedback	Load Feedback	Marker	Commutation
Feedback Only	Master Feedback	Kinetix® 5300	x	—	—	—	x	—
		Kinetix 5500	x	—	—	—	x	—
		Kinetix 5700	x	—	—	—	x	—
		ArmorKinetix® DSD	x	—	—	—	x	—
		ArmorKinetix DSM	x	—	—	—	x	—
		Kinetix 6500	x	—	—	—	x	—
Frequency Control <sup>(2)</sup>	No Feedback	Kinetix 5300	—	x	—	—	—	—
		Kinetix 5500	—	x	—	—	—	—
		Kinetix 5700	—	x	—	—	—	—
		ArmorKinetix DSD	—	x	—	—	—	—
		PowerFlex® 527	—	x	—	—	—	—
		PowerFlex 755	—	x	—	—	—	—
		PowerFlex 755TL axis 2	—	x	—	—	—	—
		PowerFlex 755TR axis 2	—	x	—	—	—	—
		PowerFlex 755TS	—	x	—	—	—	—
		PowerFlex 755TM Common Bus Inverters	—	x	—	—	—	—

Table 36 - Types of Hookup Tests (Continued)

Axis Type	Feedback Type	Drive <sup>(1)</sup>	Master Feedback	Motor and Feedback	Motor Feedback	Load Feedback	Marker	Commutation
Position Loop	Motor Feedback	Kinetix 5300	—	x	x	—	x	x
		Kinetix 350	—	x	x	—	x	—
		Kinetix 5500	—	x	x	—	x	—
		Kinetix 5700	—	x	x	—	x	x
		ArmorKinetix DSD	—	x	x	—	x	x
		ArmorKinetix DSM	—	x	x	—	x	x
		Kinetix 6500	—	x	x	—	x	x
		PowerFlex 527	—	x	x	—	—	—
		PowerFlex 755	—	x	x	—	x	x
		PowerFlex 755TL axis 2	—	x	x	—	—	—
		PowerFlex 755TR axis 2	—	x	x	—	—	—
		PowerFlex 755TS	—	x	x	—	—	—
		PowerFlex 755TM Common Bus Inverters	—	x	x	—	—	—
		Load Feedback	Kinetix 5300	—	x	x	x	x
	Kinetix 5700		—	x	x	x	x	x
	ArmorKinetix DSD		—	x	x	x	x	x
	Kinetix 6500		—	x	x	x	x	—
	Dual Feedback	Kinetix 5300	—	x	x	x		x
		Kinetix 5700	—	x	x	x	x	x
		ArmorKinetix DSD	—	x	x	x	x	x
		Kinetix 6500	—	x	x	x	x (motor)	x (motor)
		PowerFlex 755	—	x	x	x	x (motor)	x (motor)
		PowerFlex 755TL axis 2	—	x	x	x	x	—
		PowerFlex 755TR axis 2	—	x	x	x	x	—
		PowerFlex 755TS	—	x	x	x	x	—
	Dual Integrated Feedback	PowerFlex 755	—	x	x	x	x (motor)	x (motor)
		PowerFlex 755TL axis 2	—	x	x	x	x	—
		PowerFlex 755TR axis 2	—	x	x	x	x	—
		PowerFlex 755TS	—	x	x	x	x	—
		PowerFlex 755TM Common Bus Inverters	—	x	x	x	x	—

Table 36 - Types of Hookup Tests (Continued)

Axis Type	Feedback Type	Drive <sup>(1)</sup>	Master Feedback	Motor and Feedback	Motor Feedback	Load Feedback	Marker	Commutation
Velocity Loop	No Feedback	PowerFlex 755TL axis 2	—	x	—	—	—	—
		PowerFlex 755TR axis 2	—	x	—	—	—	—
		PowerFlex 755TS	—	x	—	—	—	—
		PowerFlex 755TM Common Bus Inverters	—	x	—	—	—	—
	Motor Feedback	Kinetix 350	—	x	x	—	x	—
		Kinetix 5300	—	x	x	—	x	x
		Kinetix 5500	—	x	x	—	x	—
		Kinetix 5700	—	x	x	—	x	x
		ArmorKinetix DSD	—	x	x	—	x	x
		ArmorKinetix DSM	—	x	x	—	x	x
		Kinetix 6500	—	x	x	—	x	x
		PowerFlex 527	—	x	x	—	x	—
		PowerFlex 755	—	x	x	—	—	x
		PowerFlex 755TL axis 2	—	x	x	—	—	—
		PowerFlex 755TR axis 2	—	x	x	—	—	—
		PowerFlex 755TS	—	x	x	—	—	—
	PowerFlex 755TM Common Bus Inverters	—	x	x	—	—	—	
	Load Feedback	Kinetix 5300	—	x	x	x	—	x
		Kinetix 5700	—	x	x	x	x	x
		ArmorKinetix DSD	—	x	x	x	x	x
Kinetix 6500		—	x	x	x	x	x	
Torque Loop	No Feedback	PowerFlex 755	—	x	—	—	—	—
	Motor Feedback	Kinetix 350	—	x	x	—	x	—
		Kinetix 5300	—	x	x	—	x	x
		Kinetix 5500	—	x	x	—	x	—
		Kinetix 5700	—	x	x	—	x	x
		ArmorKinetix DSD	—	x	x	—	x	x
		ArmorKinetix DSM	—	x	x	—	x	x
		Kinetix 6500	—	x	x	—	x	x
		PowerFlex 755	—	x	x	—	—	x
		PowerFlex 755TL axis 2	—	x	x	—	—	—
		PowerFlex 755TR axis 2	—	x	x	—	—	—
		PowerFlex 755TS	—	x	x	—	—	—
	PowerFlex 755TM Common Bus Inverters	—	x	x	—	—	—	
Load Feedback	Kinetix 6500	—	x	x	x	x	x	

(1) For the Kinetix 5700 drive, see the Kinetix 5700 Multi-axis Servo Drives User Manual, publication [2198-UM002](#).

(2) The Motor and Feedback hookup test is not compatible with induction motors using the Frequency Control loop configuration.

## Run a Motor and Feedback Test

The Motor and Feedback Test is the most commonly used Hookup Test because it automatically tests both the motor and feedback wiring and determines correct polarity values.



**ATTENTION:** These tests make the axis move even with the controller in remote Program mode. Before you do the tests, make sure no one is in the way of the axis.



The Motor and Feedback hookup test is not compatible with induction motors using the Frequency Control loop configuration.

Follow these steps to perform a Motor and Feedback Hookup Test.

1. Go to the Hookup Tests dialog box.

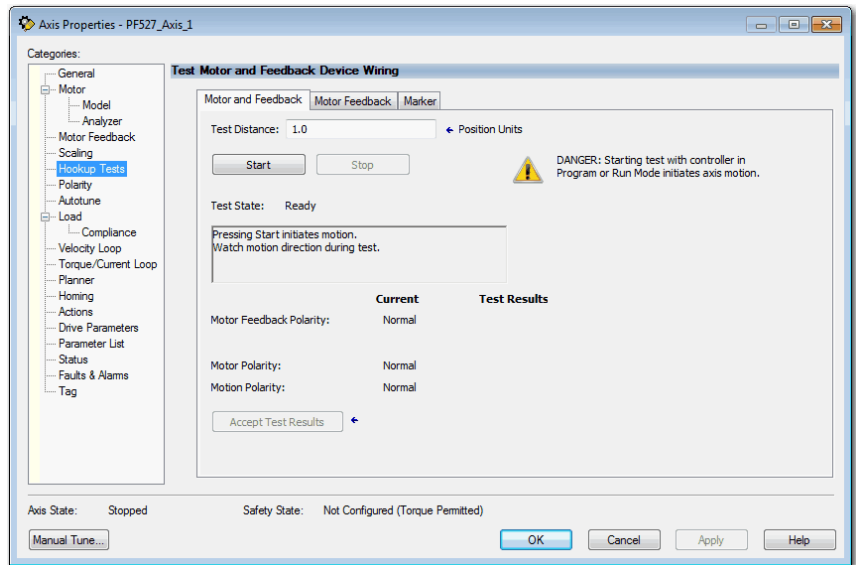

Remember that a blue arrow next to a field means that when you change its value the new value automatically gets written to the controller when you leave the field.

2. Enter the Test Distance.  
The Test Distance is the distance that the test moves the axis.
3. To run the Motor and Feedback test, click Start.

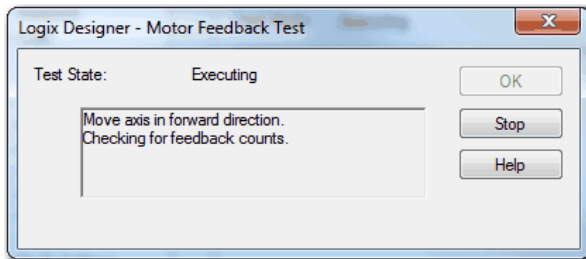

4. The axis moves on its own to test for feedback polarity and proper wiring. To check for proper rotation direction, watch the axis.  
The drive determines that the feedback device is working properly and the test passed.

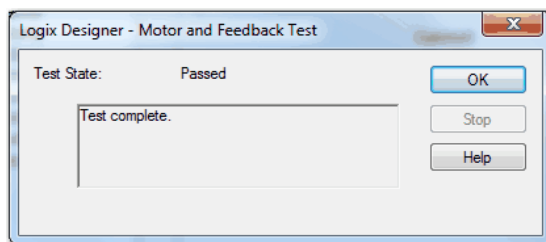

- Click OK.

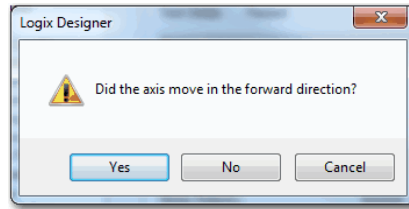

- If your axis moved in a forward direction, click yes and you see that the test result is Normal.

If the motor does not move in the forward direction, according to your application the test result is inverted. When you accept the test results the Current shows inverted.

See the [Polarity on page 130](#).

If you are satisfied with the results, you can accept the test results.

	Current	Test Results
Motor Feedback Polarity:	Normal	Normal
Motor Polarity:	Normal	Normal
Motion Polarity:	Normal	Normal

Accept Test Results ←

The test can pass but give you results that you are not expecting. In this case, you can have a wiring problem.

See the related drive documentation that is listed in the [Additional Resources on page 9](#).

- Click Yes or No depending on whether the axis moved in the forward direction for your application.
- Click Accept Results, if the test ran successfully.

## Run a Motor Feedback Test

The Motor Feedback Test checks the polarity of the motor feedback. Follow these steps to perform a Motor Feedback test.

- From the Hookup Tests dialog box, click the Motor Feedback tab.

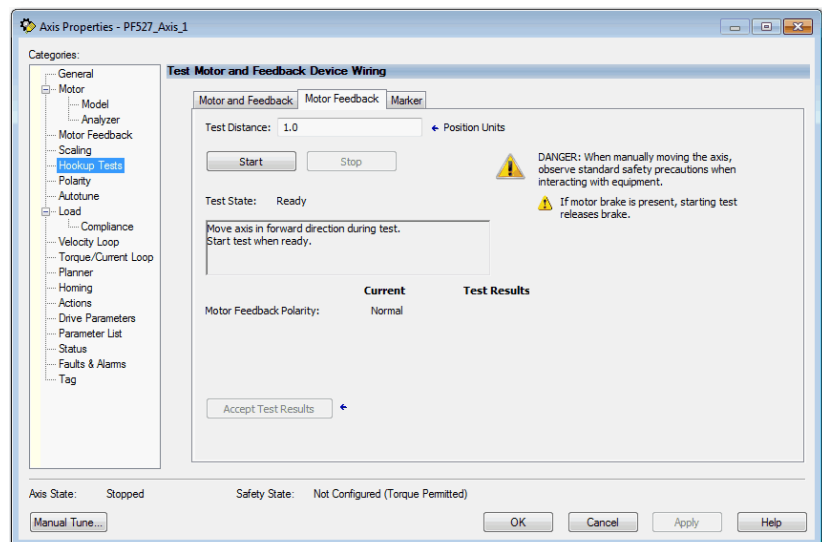

- Enter the Test Distance.
- Click Start.

## Run a Marker Test

The Marker Test checks that the drive receives the marker pulse from the position feedback device. You must manually move the axis for this test. Follow these steps to perform a Marker test.

1. From the Hookup Tests dialog box.
2. Click the Marker tab.
3. To check for the marker pulse, click Start.

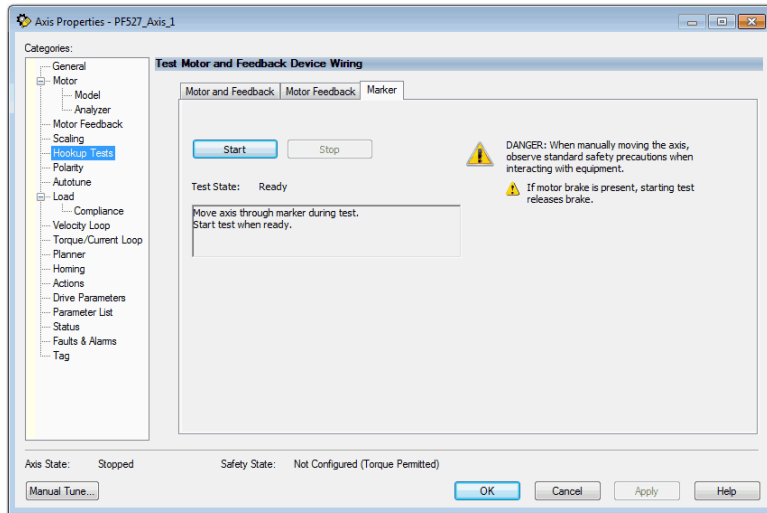

4. Manually move the axis until you get the marker pulse.

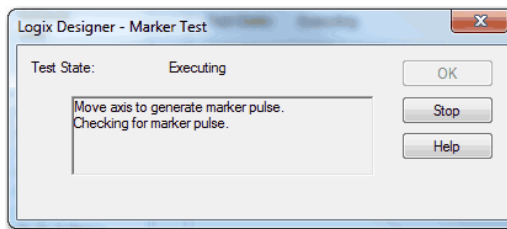

The drive receives the marker pulse and the test passed.

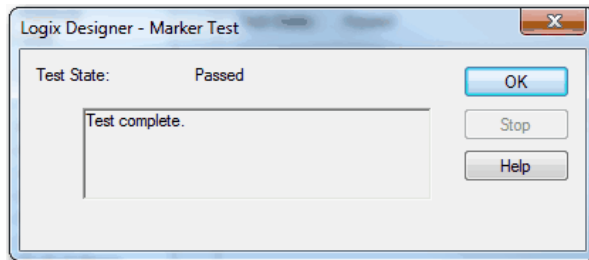

5. Click OK.

## Applying the Commutation Hookup Test

The Commutation Test determines an unknown Commutation Offset and potentially the unknown polarity of the startup commutation wiring. The Commutation Test can be also used to verify both a known Commutation Offset and the polarity startup commutation wiring. This test is applied to third-party or custom Permanent Magnet motors that are not available as a catalog number in the Motion Database.



For linear stages, make sure that there is enough available travel, otherwise the commutation test produces a fault.

When a motor needs a Commutation Offset and you are not using a catalog number as the Motor Data Source, you cannot enable the axis.

There are several different cases where the Commutation Hookup Test can be applied to a PM motor:

- [Unknown Commutation Offset](#)
- [Verification of Known Commutation Offset](#)
- [Non-standard or Incorrect Wiring](#)

## Unknown Commutation Offset

The primary use for the Commutation Hookup Test is the case where the machine is equipped with a PM motor that has an unknown Commutation Offset.

The Commutation Offset, and potentially Commutation Polarity, can be unknown for different reasons, including an unprogrammed 'smart encoder' or any generic third-party encoder where the Commutation Offset is unknown.



The Kinetix 350 and the Kinetix 5500 drives do not support the Commutation Polarity attribute.

## Verification of Known Commutation Offset

Another use of the Commutation Test is to verify that the motor is wired correctly and has the expected Commutation Offset. A machine engineer can decide not to correct for a wiring error in software but rather flag a wiring error so that it can be physically corrected. Incorrect wiring of the motor power phases, encoder signal wiring, or commutation signal wiring can show up as an unexpected Commutation Offset.

For example, suppose that a motor was wired in a 'WUV' sequence instead of the normal 'UVW' sequence. The motor would still rotate in the correct direction, but the Commutation Test indicate that the Commutation Offset was off by a factor of 120 electrical degrees.

After running the Motor and Feedback Hookup Tests, you can run the Commutation Test to determine the specific Commutation Offset and Commutation Polarity. The drive executes the Commutation Test, which includes motor rotation in the positive direction by at least one revolution. The results of the Commutation Test are reported back to compare against the known Commutation Offset and Commutation Polarity to determine if a wiring issue exists.

## Non-standard or Incorrect Wiring

The Commutation Test can also be applied to a PM motor that is wired in a non-standard manner or incorrectly. If there is incorrect wiring, it is sometimes desirable to mitigate the problem via software. You can use software mitigation on larger machines where changes to the wiring would be difficult due to the size and location of the wiring.

After running the Motor and Feedback Hookup Tests, you can run the Commutation Test to determine the specific Commutation Offset and Commutation Polarity. The drive executes the Commutation Test, which includes motor rotation in the positive direction by at least one revolution. The results of the Commutation Test are reported back for review. If the results are satisfactory, you can accept the results as part of the stored axis configuration of the controller to establish the correct wiring polarity.

## Run a Commutation Test

Set the Motor and Feedback Polarity by using the Motor and Feedback Test before running the Commutation Test. This setting helps make sure that the motor spins in the correct direction for the Commutation Test for monitoring the Commutation Angle.



Run the Motor and Feedback Test first to determine that your feedback is working. If the Feedback is not working, the Commutation Test gives you incorrect results or the test times out.

Follow these steps to run a commutation test.

1. To run the Commutation Test to determine the Commutation Offset and Commutation Polarity, click Start.



The Kinetix 350, Kinetix 5500, and PowerFlex 527 drives do not support the Commutation Polarity attribute.

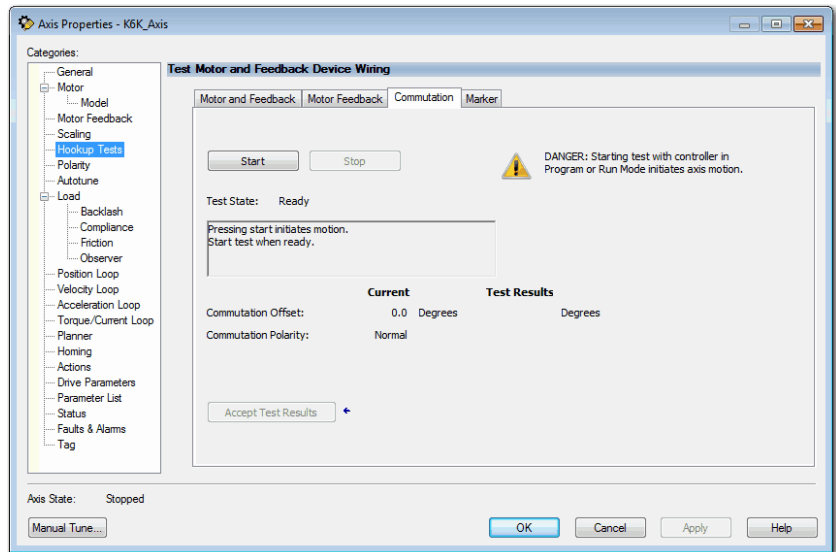

The drive executes the Commutation Test, which includes motor rotation in the positive direction by at least one revolution.

The results of the Commutation Test appear.

2. If the results are satisfactory, click Accept Test Results.

Commutation Offset and Polarity results are stored in the controller as part of the axis configuration that is sent to the drive during initialization.

## Polarity

If you have run the Motor and Feedback Hookup Test, the settings on the Polarity dialog box are already correct for the application. If the polarity settings are known and cables to the motor and feedback devices are prefabricated and tested, the polarity settings can be entered on this dialog box.

1. Right-click the servo axis that you want to change polarity and select Properties.

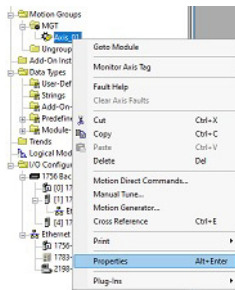

2. Click the Polarity category on the Axis properties page.
3. Set the Motion Polarity to Inverted.

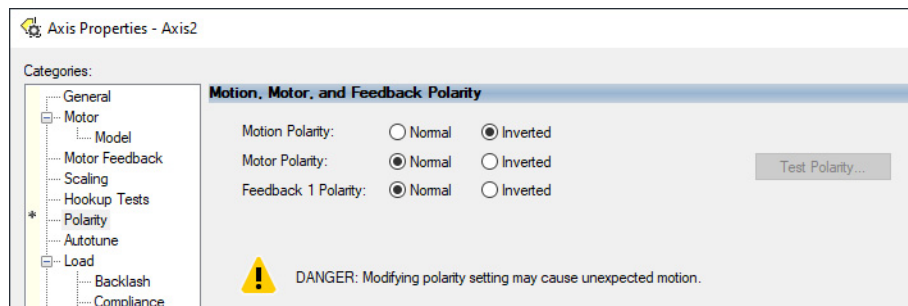

4. Click Apply and OK.

The axis is now ready for operation. You can use Direct Commands to initiate axis motion or you can run your application program. If you find that the dynamic performance of your axis does not meet your system requirements, use Autotune to improve performance.

## Autotune

Once you have set the parameters and performed tasks in the General, Motor, Motor Feedback, Scaling, Hookup Test, and Polarity dialog boxes, you are ready to Autotune, if necessary.

Typically, you do not need to use Autotune or Manual Tune. Once you select your drive and use the Motion Database as the data source, the defaults can provide adequate tuning performance. If the default values do not provide adequate performance for the application, it is recommended that the drive is configured for tuning-less operation. For information on how to configure a Kinetix 5300, Kinetix 5500, or Kinetix 5700 drive for tuning-less operation, see the Tuning-less Feature Configuration Quick Start Guide, publication [MOTION-0S001](#).

If the tuning-less features are not available for your drive, use autotune to adjust the parameters. For detailed tuning information, see the Motion System Tuning Application Technique, publication [MOTION-AT005](#).



**ATTENTION:** When you tune an axis, it moves even with the controller in Remote Program mode. In that mode, your code is **not** in control of the axis. Before you tune an axis, make sure no one is in the way of the axis. If the drive has not been enabled before (new installation), verify that you have safeguards in place to safely remove power from the drive if there is an unstable situation where the drive can produce undesired motion.

### IMPORTANT

An axis with Axis Test Mode enabled does not support Auto or Manual Tuning. Execution of the MRAT instruction on an axis with Axis Test Mode enabled is not successful.

To use the Autotune feature, use the following steps.

1. Click the Autotune dialog box.

If this box is checked, the Autotune moves the motor using a Tune Profile to measure inertia. If this box is not checked, gain and filter bandwidth calculations are still made but the inertia is not measured.

Choose whether the motor is coupled to the load or not.

To configure the Tune Profile, you enter the Travel Limit, Speed, Torque, and Direction.

Measure Inertia using Tune Profile

Motor with Load  Uncoupled Motor

Travel Limit: 0.0 ← Position Units

Speed: 0.0 ← Position Units/s

Torque: 100.0 ← % Rated

Direction: Forward Uni-directional

2. Set the Travel Limit that is based on the travel constraints of the machine.
3. Set the Speed to the expected operation speed.
4. Set the Torque to the level that you want to apply to the motor during the Autotune. The default of 100% Rated Torque usually give good results.
5. Set the Direction that is based on machine constrains. Unidirectional tune profile measures inertia and friction. Bidirectional tune profile adds measurement of active torque loading.



Blue arrows next to a field mean that these values are immediately applied. Once you put a value in the field and then leave that field, it is automatically sent to the controller.

6. Click Start.

This message appears if you have edits that have not been applied. If you do not save edits that are pending, Autotune does not run.

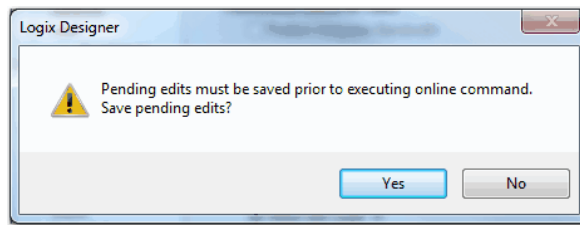

The Autotune status displays Success. A tune configuration fault can occur if any number of attributes are zero.

**Table 37 - Tune Configuration Fault**

Fault	Description
Tune Configuration Fault	<p>A tune configuration fault can occur if any number of attributes are zero. This fault occurs only when you use Nameplate Data as the motor data source. The following attributes are checked for zero:</p> <ul style="list-style-type: none"> <li>• Tuning Torque</li> <li>• Conversion Constant</li> <li>• Drive Model Time Constant</li> <li>• System Damping (Damping Factor)</li> <li>• Rotary Motor Inertia</li> <li>• Linear Motor Mass                             <ul style="list-style-type: none"> <li>- The Kinetix 350 drive does not support this attribute.</li> </ul> </li> <li>• Motor Rated Continuous Current</li> <li>• PM Motor Rotary Voltage Constant</li> <li>• PM Motor Linear Voltage Constant</li> <li>• Rotary Motor Rated Speed</li> <li>• Linear Motor Rated Speed</li> </ul>

The Autotune profile accelerates and decelerates the motor according to the Tune Direction. Once the Autotune is finished, the test state changes.

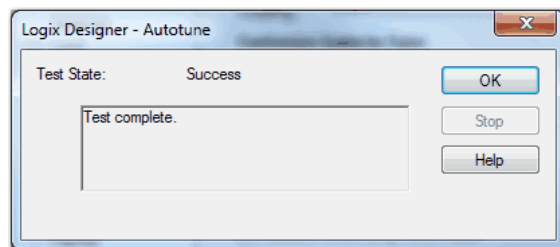

## 7. Click OK.

After completing the Autotune profile, the measurements that are made during this process are used to update the fields in the Gains Tuned and Inertia Tuned grids.

Check your Tune Status

The screenshot shows a dialog box titled 'Tune Status: Success'. It contains two tables: 'Loop Parameters Tuned' and 'Load Parameters Tuned'. The 'Loop Parameters Tuned' table has columns for Name, Current, Tuned, and Units. It lists three parameters: PositionLoopBandwidth (Current: 19.469685, Tuned: 19.479559, Units: Hz), PositionIntegratorBandwidth (Current: 0.0, Tuned: 0.0, Units: Hz), and VelocityLoopBandwidth (Current: 77.87874, Tuned: 77.918236, Units: Hz). The 'Load Parameters Tuned' table lists MaximumAcceleration (Current: 14087.599, Tuned: 14087.599, Units: Po...), MaximumDeceleration (Current: 14087.599, Tuned: 14087.599, Units: Po...), and SystemInertia (Current: 0.01434175, Tuned: 0.01434175, Units: % ...). An 'Accept Tuned Values' button is at the bottom.

Any value that has an asterisk in the leftmost column has another value from its tuned value.

## 8. You can compare existing and tuned values for your gains and inertias with the prospective tune values.

The first screenshot shows the 'Loop Parameters Tuned' table with a tooltip over the 'Current' value of 19.469685 for PositionLoopBandwidth. The tooltip displays the full value: 19.469685. A note says: 'If the value does not fit in the column, a tool tip appears to show the complete value. You can also change the column widths.'

The second screenshot shows the same dialog box with the 'Accept Tuned Values' button highlighted.

## 9. Choose to accept the new values and apply them to the controller.

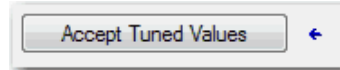

Now you can run the system with the new gain set and evaluate performance. You can improve the performance by adjusting application type, loop response, and/or load coupling selections.



If your application requires stricter performance, you can further improve performance with manual tuning.

See [When to Manually Tune an Axis on page 169](#).

## Load

The Load dialog box contains the characteristics of the motor load. You can also use the values that are provided by autotune. The Autotune automatically sets most of these values:

- If you use the catalog number as the Data Source, the Motor Inertia, Total Inertia, and System Inertia are pre-populated with the correct values.
- If you know what the Load Ratio values are, you can enter that information on the Load dialog box or you can use the values that are provided by Autotune.

**IMPORTANT** If utilizing the tuning-less features, it is recommended to set the Load Ratio to zero. For information on how to configure a Kinetix 5300, Kinetix 5500, or Kinetix 5700 drive for tuning less operation, see the Tuningless Feature Configuration Quick Start Guide, publication [MOTION-QS001](#).

Figure 88 - Kinetix 6500 Load Dialog Box

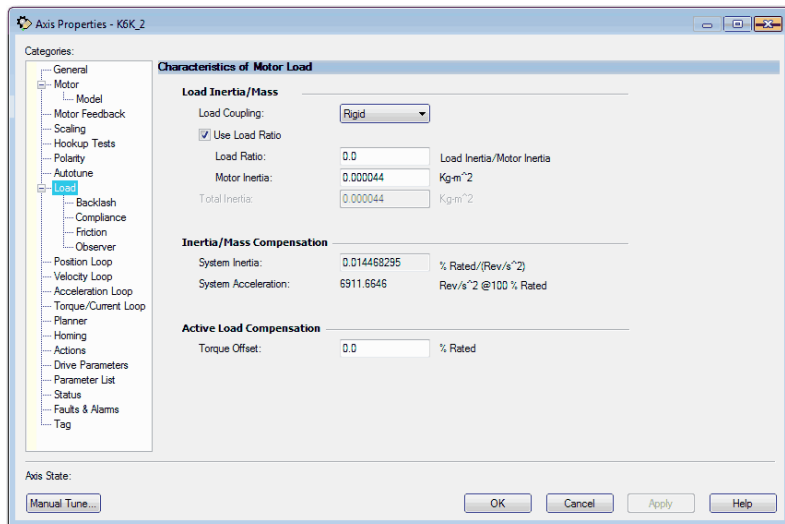

Table 38 - Characteristics of Motor Load Fields

Parameter	Description
Load Coupling	Lets you control how tightly the system is physically coupled. Your choices are the following: <ul style="list-style-type: none"> <li>Rigid (default)</li> <li>Compliant</li> </ul> Load Coupling appears dimmed when the axis is Servo On.
InertiaCompensation	Inertia compensation controls relate to rotary motors.
Load Ratio	The value of the Load Ratio attribute represents the ratio of the load inertia or mass to the motor inertia, or mass.
Motor Inertia	The Motor Inertia attribute is a float that specifies the unloaded inertia of a rotary motor.
Total Inertia	TotalInertia represents the combined inertia of the rotary motor and load in engineering units.
Inertia/Mass Compensation	Inertia compensation controls relate to rotary motors. Mass compensation controls relate to linear motors.
System Acceleration	System Inertia is recalculated anytime the System Acceleration changes: <ul style="list-style-type: none"> <li>System Inertia = 0, if System Acceleration = 0</li> <li>System Inertia = 1/System Acceleration</li> <li>Units are Rev/s<sup>2</sup> @100% Rated</li> </ul>
System Inertia	The torque or force-scaling gain value converts commanded acceleration into equivalent rated torque/force. Properly set, this value represents the total system inertia or mass. System Inertia is a read-only field that is based on Total Inertia. The software recalculates System Acceleration anytime the dependent attributes change: <ul style="list-style-type: none"> <li>If the data Source is Motor Catalog Number, the System Acceleration value is read directly from the motion database.</li> <li>If the Data Source is Nameplate data sheet, the System Acceleration value is calculated.</li> <li>If the Data Source is Drive NV or Motor NV, this field is blank.</li> </ul>
Torque Offset	The Torque Offset attribute provides a torque bias when performing closed-loop control.
Mass Compensation	Mass compensation controls relate to linear motors.
Motor Mass	The mass of the motor displays in Kg units. This control is calculated based on the load inertia ratio. Generally it is not equal to 0 for Kinetix drives.
Total Mass	Total Mass represents the combined mass of the linear motor and load in engineering units.
Load Backlash <sup>(1)</sup>	This parameter provides backlash configuration options for the load of the motor.

**Table 38 - Characteristics of Motor Load Fields (Continued)**

Parameter	Description
Load Compliance <sup>(1)</sup>	<ul style="list-style-type: none"> <li>The Torque Low Pass Filter Bandwidth attribute is the break frequency for the second order low pass filter that is applied to the torque reference signal.</li> <li>The Torque Notch Filter Frequency attribute is the center frequency of the notch filter that is applied to the torque reference signal. A value of 0 for this attribute disables this feature.</li> <li>The Torque Lag Filter Gain attribute sets the high frequency gain of the torque reference Lead-Lag Filter. A value greater than one results in a lead function and a value less than one results in a lag function. A value of 1 disables the filter.</li> <li>The Torque Lag Filter Bandwidth attribute sets the pole frequency for the torque reference Lead-Lag Filter. A value of 0 disables the filter.</li> </ul>
Load Friction <sup>(1)</sup>	<ul style="list-style-type: none"> <li>Sliding Friction Compensation is the value that is added to the current/torque command to offset the effects of coulomb friction.</li> <li>Compensation Window defines a window around the command position.</li> </ul>
Load Observer <sup>(2)</sup>	This parameter configures the operation of the Load Observer.

(1) The Kinetix 350 does not support this parameter.

(2) The Kinetix 5300, Kinetix 5500, Kinetix 5700, and Kinetix 6500 drives natively support this parameter.

See the Integrated Motion on the EtherNet/IP Network Reference Manual, publication [MOTION-RM003](#), for detailed descriptions of the AXIS\_CIP\_DRIVE attributes.

## Load Observer

The Load Observer feature is a control loop inside the drive that estimates the mechanical load on the motor and compensates for it. This feature lets the control loops to treat the motor as if it is unloaded and relatively easy to control. The Load Observer automatically compensates for disturbances and load dynamics, such as sudden inertia changes, compliance, backlash, and resonances that are within the bandwidth of the Load Observer.

For detailed tuning information, see the Motion System Tuning Application Technique, publication [MOTION-ATO05](#).

### Benefits of Load Observer

The Load Observer Feature provides the following benefits:

- Provides relatively high-performance motion control without tuning
- Minimizes the need to retune to account for machine wear over time
- Automatically compensates for changes in vibration and resonance that are within the bandwidth of the Load Observer
- Mitigates periodic identification of in-band resonance to compensate for them

### How Load Observer Functions

The Load Observer acts on the acceleration signal within the control loops and monitors the Acceleration Reference and the Actual Position feedback. The Load Observer models an ideal unloaded motor and generates a load Torque Estimate that represents any deviation in response of the actual motor and mechanics from the ideal model. This deviation represents the reaction torque that is placed on the motor shaft by the load mechanics. Closed-loop operation compensates the deviation, which is estimated in real time. See [Figure 89 on page 136](#) for an example Load Observer block diagram.

Figure 89 - Load Observer Block Diagram

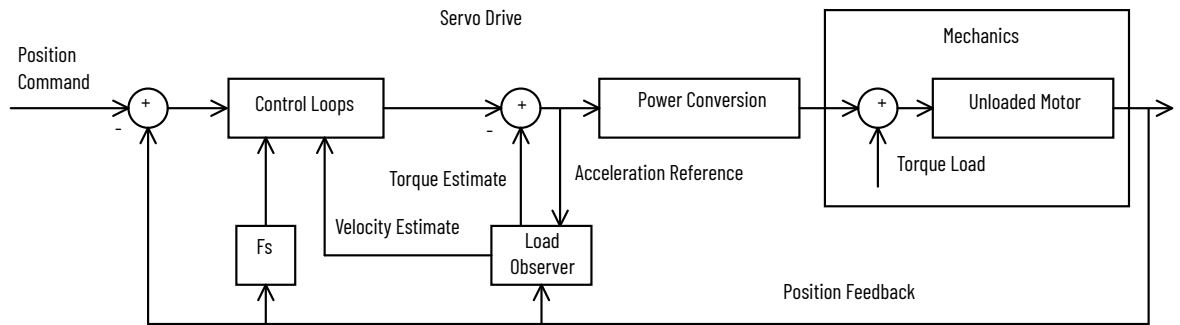

The Load Observer also generates a Velocity Estimate signal that you can apply to the velocity loop. The Velocity Estimate has less delay than the Velocity Feedback signal derived from the actual feedback device. It also helps to reduce high frequency output noise that the aggressive action of the Load Observer on the acceleration reference causes. Together, Load Observer with Velocity Estimate provides the best overall performance for positioning applications. Table 39 describes the Load Observer configuration settings.

Table 39 - Load Observer Configuration Settings

Configuration	Description
Disabled	Load Observer is inactive.
Load Observer Only	Provides a torque estimate only.
Load Observer with Velocity Estimate	The standard Load Observer operation. Provides torque and velocity estimates.
Velocity Estimate Only	Provides only a velocity estimate.
Acceleration Feedback	Provides acceleration feedback by disconnecting the Acceleration Reference to the Load Observer.

### Load Observer Configuration

This section applies to only the Load Observer feature for the Kinetix 5300, Kinetix 5500, Kinetix 5700, Kinetix 6500, and PowerFlex 755T drives. Click the Observer tab in the Axis Properties dialog box. Here, the Load Observer mode can be selected with the Configuration dropdown menu. See Table 39 for descriptions of each setting. If Load Observer is enabled, the recommended Configuration setting is Load Observer with Velocity Estimate for positioning applications. Access to Load Observer bandwidth (Kop) and Load Observer Integral Bandwidth (Koi) is also shown. Typically, Koi = 0.

Gains are limited to 500 Hz in drive firmware revision 2.160 and earlier. In drive firmware revision 2.170 and later, the gain limits are increased to 10,430 Hz.

The Load Observer can be configured in various ways by using the Load Observer Configuration attribute. The standard configuration is Load Observer with Velocity Estimate. This configuration approximates the load torque and minimizes the phase lag associated with the velocity feedback.

Figure 90 - Load Observer with Velocity Estimate: Kinetix 6500 Drive

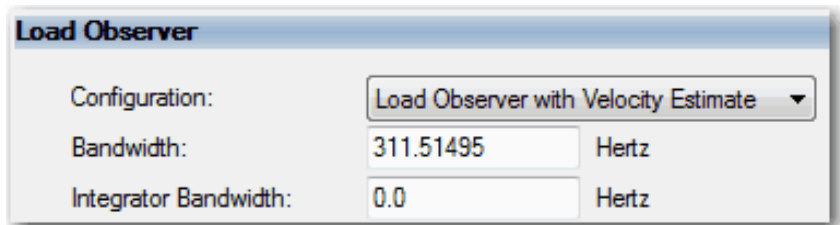

For more information, see the Motion System Tuning Application Technique, publication [MOTION-ATO05](#).

## Adaptive Tuning

The Adaptive Tuning feature is an algorithm inside of the drive. This feature continuously adjusts or adapts various filter parameters and control loop gains to compensate for unknown and changing load conditions while the drive is running. Its primary functions are as follows:

- Automatically adjust torque loop notch and low pass filter parameters to suppress resonances
- Automatically de-tune control loop gains to avoid instability when it is detected

For detailed tuning information, see the Motion System Tuning Application Technique, publication [MOTION-ATO05](#).

### Benefits of Adaptive Tuning

Adaptive Tuning performs the following:

- Automatically suppresses changing resonances
- Minimizes periodic identification of resonance and retuning
- Mitigates the need for a tuning expert
- Reduces decommissioning time, especially for high axis count
- Minimizes the power consumption, machine vibration, and errors

### How Adaptive Tuning Functions

Adaptive Tuning is always running in the background to detect motor side resonances. Adaptive Tuning periodically analyzes the frequency response of torque loop signals to identify, track, and measure resonances. Adaptive Tuning also analyzes the frequency response of the command signal to make sure that dominant command frequencies are not mistaken for resonances. This process is known as command rejection. The action that is taken to change tuning parameters largely depends on the adaptive tuning mode of operation.

The configurable Adaptive Tuning parameters from the Compliance Category of the Axis Properties are listed in the following table. For a list of all Adaptive Tuning attributes, see the Motion System Tuning Application Technique, publication [MOTION-ATO05](#).

**Figure 91 - Adaptive Tuning Parameters**

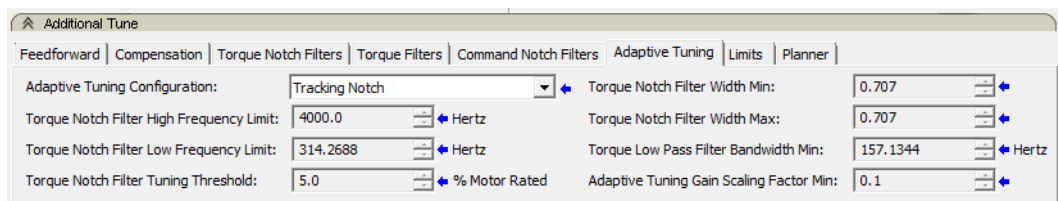

**Table 40 - Adaptive Tuning Attributes**

Parameter Name	Description	Default Value <sup>(1)</sup>	Range/Units
Torque Low Pass Filter Bandwidth	Break frequency for the second order low pass filter that is applied to the torque reference signal.	<ul style="list-style-type: none"> <li>• 5 x load observer bandwidth</li> <li>• 5 x velocity loop bandwidth<sup>(2)</sup></li> </ul>	0...10000 Hz
Torque Notch Filter N Frequency	Center frequency of each notch filter that is applied to the torque reference signal.	0	0...10000 Hz
Adaptive Tuning Configuration	Controls the Adaptive Tuning feature mode of operation.	0 = Disabled	0 = Disabled 1 = Tracking Notch 2 = Gain Stabilization 3 = Tracking Notch and Gain Stabilization
Tracking Notch Filters <sup>(3)</sup>	The number of torque notch filters that are automatically tuned by Adaptive Tuning.	4	0...4 tracking notch filters

Table 40 - Adaptive Tuning Attributes (Continued)

Parameter Name	Description	Default Value <sup>(1)</sup>	Range/Units
Torque Notch Filter High Frequency Limit	Adaptive Tuning identifies resonances that are not associated with the command between these low and high frequency limits with magnitudes above this tuning threshold.	4000	1...4000 Hz
Torque Notch Filter Low Frequency Limit		4 * Z2 * Velocity Loop BW	1...2000 Hz
Torque Notch Filter Tuning Threshold		5	0...100% of motor rated torque
Command Notch Filter N Frequency	Center frequency of each command notch filter that is applied to the command signal.	0	0...10000 Hz

(1) Some of the default values differ depending on the drive type and firmware revision that is used for the application.  
 (2) When load observer is disabled.  
 (3) The option for the number of tracking notch filters differs depending on the drive type and firmware revision that is used for the application.

For the purposes of this manual, resonances are characterized as follows:

- HF resonances are above the low frequency limit
- LF resonances are below the low frequency limit
- MF resonances are slightly above the low frequency limit

### Adaptive Tuning Configuration

The modes of adaptive tuning operation include:

- Disabled
- Tracking Notch
- Gain Stabilization
- Tracking Notch and Gain Stabilization

You access adaptive tuning from the Compliance tab on the Load Category page.



The PowerFlex 755T drives offer Adaptive Tuning, but only the 'Tracking Notch' option is available.

#### Disabled

Adaptive Tuning is always running in the background to identify motor side resonances, even when the feature is disabled.

No action is taken to compensate for the identified resonances in this mode. The result is status only, which lets you create a custom Ladder Logic to react to changes. This function is useful for condition monitoring, diagnostics, and preventative maintenance purposes in tracking HF resonances that change over time. The Adaptive Tuning output parameters can be selected and monitored in the Drive Parameters tab of the Axis Properties dialog box.

## Tracking Notch

Typically the Torque Notch Filter Frequencies on the Compliance tab of the Axis Properties dialog box are applied to the torque notch filters. In this mode, the Torque Notch Filter Frequency Estimates that are identified by the drive are applied to the torque notch filters instead.

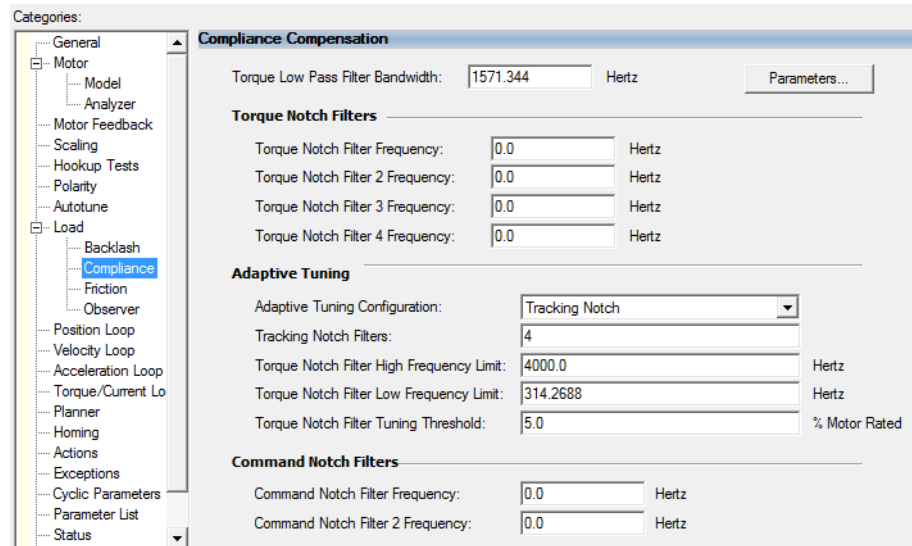

## Gain Stabilization

Adaptive Tuning performs two primary functions in modes with Gain Stabilization.

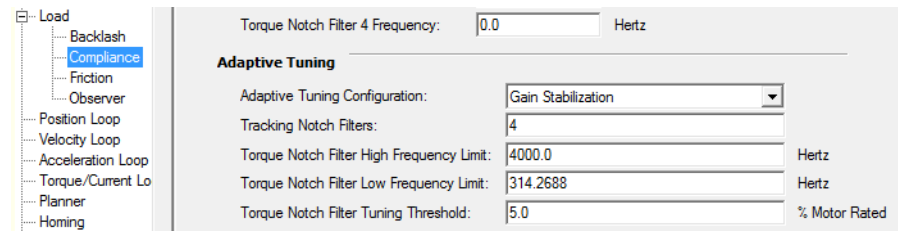

Adaptive Tuning enables and tunes the low pass filter to suppress resonances if any are identified above the low frequency limit. Typically the Torque Low Pass Filter Bandwidth that is visible on the Compliance tab of the Axis properties dialog box is applied to the low pass torque filter. With Adaptive Tuning, the Torque Low Pass Filter Bandwidth Estimate that is identified by the drive is applied to the torque low pass filter instead. The bandwidth estimate is incrementally decreased from its default value until the identified HF resonances are suppressed or an LF resonance or instability occurs.

The gain stabilization function detunes control loop gains to suppress any remaining resonances and stabilize the system. The Adaptive Tuning Gain Scaling factor scales the following gains:

- Load Observer Bandwidth
- Load Observer Integrator Bandwidth
- Velocity Loop Bandwidth
- Velocity Loop Integrator Bandwidth
- Position Loop Bandwidth
- Position Loop Integrator Bandwidth

The actual control loop gains are the values that are shown in the Axis Properties dialog box that is multiplied by the gain scaling factor. The scaling factor is incrementally decreased from its default value until the system is stable. When Gain Stabilization is not enabled, the scaling factor is reset to its default value of 1 so that control loop gains are not affected.

Gain Stabilization is good for situations where there are more resonances than there are notch filters and for keeping the axis stable. Instability and audible noise is caused from the following situations:

- HF resonances that filters do not already suppress
- MF resonances that filters suppress where the filter bandwidths are too close to the closed-loop bandwidth
- LF resonances that result when Load Observer is not applied with the recommended out-of-box settings
- LF resonances that result from classical instability

---

**IMPORTANT** We do not recommend that you enable Gain Stabilization on vertical loads as detuning can cause load drops.

---

### Tracking Notch and Gain Stabilization

When Tracking Notch and Gain Stabilization are enabled, the drive applies the Tracking Notches if necessary, followed by Gain Stabilization, if necessary.

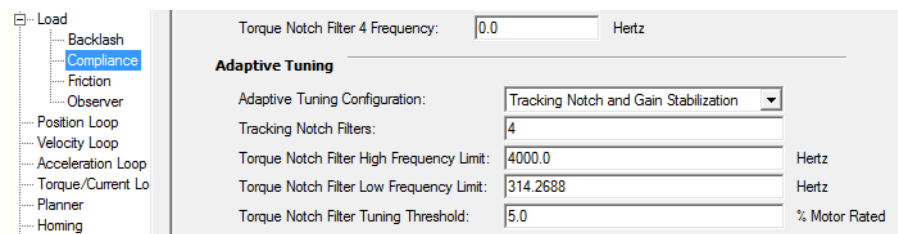

Notch Filter Tuning sets the torque notch filters to suppress High Frequency resonances that may exist. Gain Stabilization applies the low pass filter to suppress additional HF resonances if they exist. This function is useful for suppressing more HF resonances than there are notch filters. If the system is unstable, Gain Stabilization incrementally detunes control loops until the system is stable.

The system is detuned if one or more of the following conditions exist:

- A torque notch filter was set to suppress a MF resonance. The width of the torque notch filter is wide enough or its frequency is close enough to the closed-loop bandwidth to cause instability
- The torque low pass filter was set to suppress an MF resonance, but its bandwidth is close enough to the closed-loop bandwidth to cause instability
- Any additional unsuppressed resonances are present.

For detailed descriptions of the Adaptive Tuning Status Bits, see the Motion System Tuning Application Technique, publication [MOTION-AT005](#).

## Command Notch Filters

Even when all motor side resonances are suppressed and the motor shaft is tightly controlled using closed loop feedback, the load end effector can still oscillate at a few Hertz through a compliant mechanical connection or linkage to the motor. These oscillations are load-side resonances that are unobservable in the feedback signal and are not measurable by the feedback device on the motor.

### Benefits of Command Notch Filters

The Command Notch Filters can be used to minimize load side resonances that result in end effector vibration that is common in robots, cranes, cantilevered loads, anti-sway, liquid sloshing, laser cutting, and material handling applications.

## Command Notch Filter Configuration

To apply a Command Notch filter, first specify a smooth reference move profile. Then determine the load oscillation frequency with either an empirical formula, a stopwatch, or a high-speed camera and then apply a command notch filter at that frequency.

**Command Notch Filters**

Command Notch Filter Frequency:  Hertz

Command Notch Filter 2 Frequency:  Hertz

For more details about the Command Notch filters, see the Motion System Tuning Application Technique, publication [MOTION-ATO05](#).

## Load Ratio Data from Motion Analyzer

Load Ratio can also be found through Autotune from Motion Analyzer.

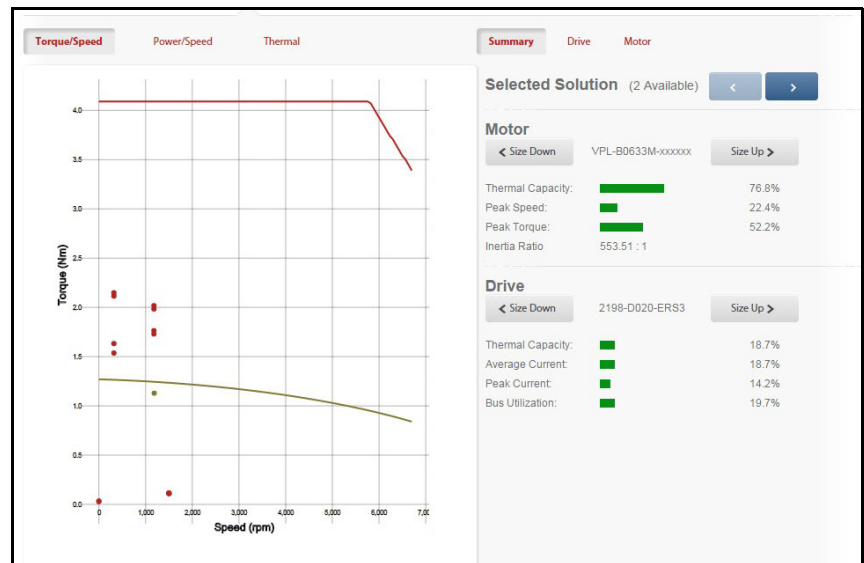

If you do not want to run the Autotune, you can manually enter the load ratio from other sources such as Motion Analyzer.

Thermal Capacity:	<div style="width: 76.8%;"></div>	76.8%
Peak Speed:	<div style="width: 22.4%;"></div>	22.4%
Peak Torque:	<div style="width: 52.2%;"></div>	52.2%
Inertia Ratio	553.51 : 1	

See [Help for Selecting Drives and Motors on page 13](#) for more information about the Motion Analyzer.

## Test an Axis with Motion Direct Commands

Motion direct commands let you issue motion commands while you are online without having to write or execute an application program. You must be online to execute a Motion Direct Command. There are several ways to access the Motion Direct Command.

Motion Direct Commands (MDC) are useful when you are commissioning or troubleshooting a motion application. During commissioning, you can configure an axis and monitor the behavior by using Trends in the Controller Organizer. Use of Motion Direct Commands can fine-tune the system with or without load to optimize its performance. When testing and/or troubleshooting, you can issue Motion Direct Commands to establish or re-establish conditions such as Home. Often during initial development, test the system in small manageable areas. These tasks include the following:

- Home to establish initial conditions
- Incrementally Move to a physical position
- Monitor system dynamics under specific conditions

## Access Motion Direct Commands for an Axis or Group

To access the Motion Direct Commands for the Motion Group or axis, right-click the Group or Axis in the Controller Organizer and choose Motion Direct Commands.

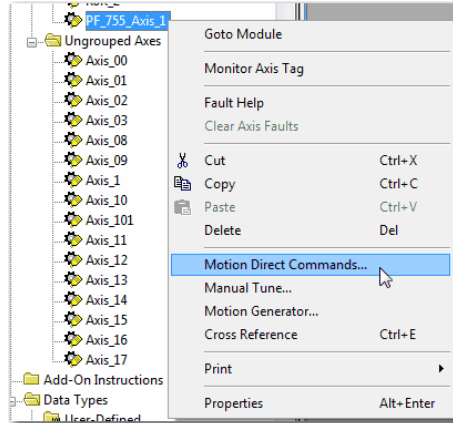
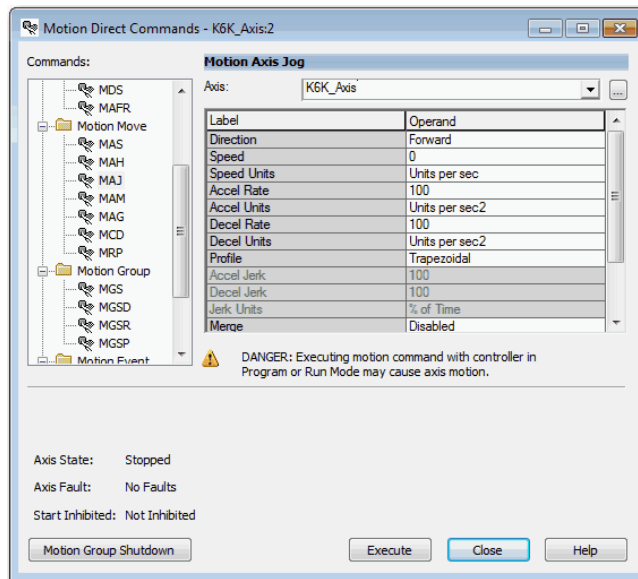
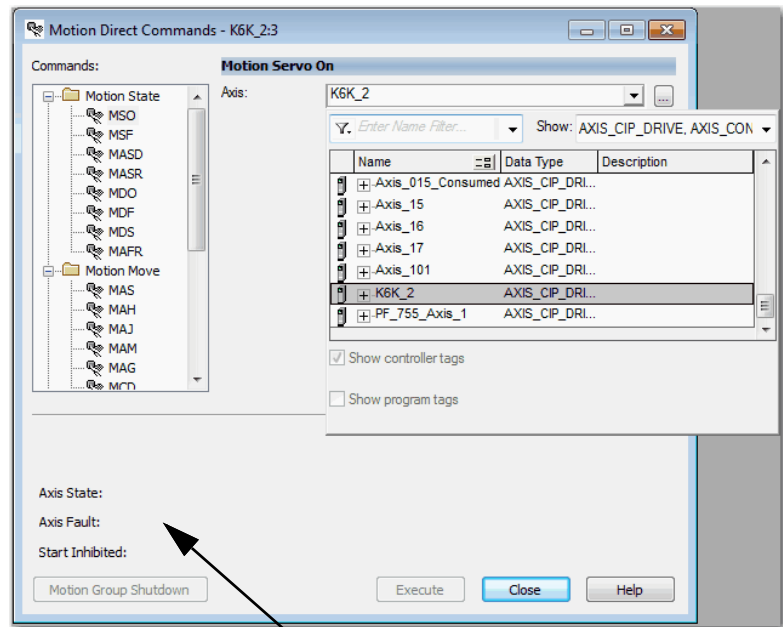

Figure 92 - Motion Direct Commands Dialog Box



The content of the Motion Direct Command dialog box varies, depending on the command you have chosen. In the Command list, you can either type the mnemonic and the list advances to the closest match or you can choose a command from the Axis dropdown menu. Choose the desired command and its dialog box appears.

You can access an axis by using the dropdown list. Axis status indicators are in this dialog box.



Axis Status Indicators

This dialog box is an example of axis indicator values.

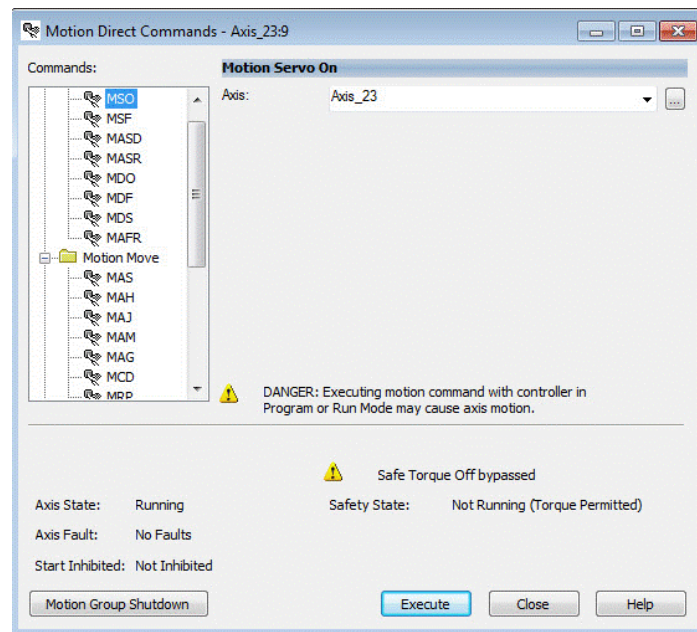

**IMPORTANT** The device spins at the command velocity once you execute an MDS command if you use a PowerFlex 755 drive in Velocity Mode with Flying Start Enable set to true.

For more information about the Flying Start Attribute, see the Integrated Motion on the EtherNet/IP Network Reference Manual, publication [MOTION-RM003](#).

## Understanding STO Bypass When Using Motion Direct Commands

For complete information about Motion Direct Commands in motion control systems including the Safe Torque Off feature, see the publications that are listed in the [Additional Resources on page 9](#).

The drive does not allow motion while the safety controller is in Program mode by default. This condition applies only if a safety connection between the GuardLogix® safety controller and the drive was established at least once after the drive was received from the factory.

The drive does not allow motion because the Safety Task is not executed while the GuardLogix safety controller is in Program mode. This condition applies to applications that run in a single-safety controller (with Motion and Safety connections). The standard controller can transition to Program mode while the safety controller stays in Run mode and continues to execute the Safety Task. This transition occurs when an integrated safety drive has a Motion connection to a standard controller and a separate Safety connection to a dual-safety controller.

However, applicable drive systems are designed with a bypass feature for the STO function in single-safety controller configurations. You can use the Motion Direct Command (MDC) feature to allow motion while following all necessary and prescribed steps per machine safety operating procedures.



**ATTENTION:** Consider the consequences of allowing motion by using MDC when the controller is in Program mode. You must acknowledge warning messages in the Logix Designer application that warn of the drive bypassing the STO function and unintended motion can occur. The integrated safety drive does not respond to the request of STO function if MDC mode is entered.

**ATTENTION:** It is your responsibility to maintain machine safety integrity while executing Motion Direct Commands. One alternative is to provide Ladder Logic for Machine Maintenance mode that leaves the controller in Run mode with safety functions executing.

[Table 41](#) defines which drive supports the type of STO functionality.

**Table 41 - Drives That Support Safe Torque Off (STO)**

Drive	Mechanism	Axis Status	STO Configuration
Kinetix 350 servo drive	Hardwired	GuardStatus	None
Kinetix 5300 servo drive	Hardwired	GuardStatus	None
Kinetix 5500 2198-Hxxx-ERS servo drives	Hardwired	GuardStatus	None
Kinetix 5500 2198-Hxxx-ERS2 servo drives	Integrated	SafetyStatus	Logix Designer application
Kinetix 5700 2198-xxxx-ERS3 servo drives	Hardwired	GuardStatus	None
Kinetix 5700 2198-xxxx-ERS4 servo drives	Integrated	SafetyStatus	Logix Designer application
ArmorKinetix Distributed Servo Drive - 2198-DSDxxx-ERSx	Integrated	SafetyStatus	Logix Designer application
ArmorKinetix Distributed Servo Motor - 2198-DSMxxx-ERSx	Integrated	SafetyStatus	Logix Designer application
Kinetix 6500 servo drives with 2094-EN02D-M01-S0, Safe Torque Off control module	Hardwired	GuardStatus	Webpage
Kinetix 6500 servo drives with 2094-EN02D-M01-S1, Safe speed monitoring	Hardwired	GuardStatus	Webpage
PowerFlex 755 drive and PowerFlex 755T drive products with Safe Torque Off Option module (20-750-S0)	Hardwired	GuardStatus	Webpage
PowerFlex 755 drive with Safe Speed Monitor Option module (20-750-S1)	Hardwired	GuardStatus	Webpage
PowerFlex 755 drive and PowerFlex 755T drive products with Integrated Safety - Safe Torque Off Option module (20-750-S3)	Integrated	SafetyStatus	Logix Designer application
	Hardwired	GuardStatus	None
PowerFlex 755 and PowerFlex 755T drive products with Integrated Safety Functions Option Module (20-750-S4)	Integrated	SafetyStatus	Logix Designer application
	Hardwired	GuardStatus	None
PowerFlex 527 drive	Hardwired	GuardStatus	None
	Integrated	SafetyStatus	Logix Designer application

For detailed information on the Safe Torque Off function, see one of the following publications:

- Kinetix 5300 Single-axis EtherNet/IP Servo Drives User Manual, publication [2198-UM005](#)
- Kinetix 5500 Servo Drives User Manual, publication [2198-UM001](#)
- Kinetix 5700 Multi-axis Servo Drives User Manual, publication [2198-UM002](#)
- ArmorKinetix System User Manual, publication [2198-UM006](#)
- PowerFlex 527 Adjustable Frequency AC Drive User Manual, publication [520-UM002](#)
- PowerFlex 750-Series Safe Speed Monitor Option Module Safety Reference Manual, publication [750-RM001](#)
- PowerFlex 750-Series Safe Torque Off Option Module User Manual, publication [750-UM002](#)
- PowerFlex 755 Integrated Safety - Safe Torque Off Option User Manual, publication [750-UM004](#)
- PowerFlex 755/755T Integrated Safety Functions Option Module User Manual, publication [750-UM005](#)

**Notes:**

## Axis Test Mode

### What is Axis Test Mode?

Axis Test Mode allows CIP™ motion simulation on physical Logix controllers and FactoryTalk® Logix Echo controllers. Use Axis Test Mode to develop and test application programs without a controller I/O connection to a set of physical CIP motion drives, motors, or machine components.

Perform development and testing without modifying motion and safety logic. In Axis Test Mode, the logic performs the same as on physical hardware.

Axis Test Mode supports the Controller Loopback model where the command position becomes the actual position in the simulated axis:

- Logix Designer application version 35 added motion simulation for CIP drives.
- Logix Designer application version 36 added motion and safety simulation for CIP Safety™ drives.

### Axis Test Mode Scope

Axis Test Mode requires the same drive configuration (CIP axis that is associated with a drive) as for a physical drive. Axis Test Mode supports motion and safety simulation on:

- ControlLogix® 5580 and GuardLogix® 5580 controllers
- CompactLogix™ 5380 and Compact GuardLogix 5380 controllers that support CIP motion
- FactoryTalk Logix Echo 5580 controllers

Axis Test Mode supports:

- Single-axis and multi-axis CIP drive types with position loop control mode.
- Limited simulation support for CIP motion converters, feedback-only type axes, velocity, and torque loop.

For more information on simulation details, see the Motion on the EtherNet/IP Network reference manual, publication [MOTION-RM003](#).

Axis Test Mode does not simulate the following:

- Generic drives
- SERCOS, analog, and virtual axes
- A mix of physical and test mode axes in the same multi-axis drive (for example, a Kinetix® 5700 dual-axis inverter)
- Home and registration instructions that require interaction with a drive or motor, for example, switch/marker
- Advanced drive features like Load observer, Flying Start, torque proving, adaptive tuning, auto tuning, hookup tests, and registration to an input
- Cyclic readable and writable data, except for Safety Status A and Safety Status B
- Motion diagnostic page data

For more information on simulated attributes, see the Motion on the EtherNet/IP Network reference manual, publication [MOTION-RM003](#).

# Use Cases for Axis Test Mode

Axis Test Mode can help in these programming situations:

Situation	Description
Commissioning	<ul style="list-style-type: none"> <li>Develop application programs and verify the programs by using a FactoryTalk Echo controller, possibly with Emulate3D™, before you download to a physical controller/system.</li> <li>Enable only the desired sections of machines during startup.                             <ul style="list-style-type: none"> <li>Little or no code modification is required.</li> <li>Allows axis simulation without manually changing axis types, for example from CIP to virtual.</li> <li>Virtualize an entire robot.</li> <li>Virtualize an entire ICT track.</li> </ul> </li> <li>Enable/disable sections that are not physically present.</li> <li>Use the same ACD for machine execution and for simulating what-if scenarios, improvements, and changes.</li> </ul>
Maintenance	<ul style="list-style-type: none"> <li>Test operation during recipe adjustments before running on physical equipment.</li> <li>Decommission faulty or bypassable sections for brief periods of time.</li> </ul>
Permanent Out of Service	Disable sections that are no longer required without removing logic from your application.
Simulation	Replay events in the controller for analytics and troubleshooting purposes in a simulation environment.

## Enable Axis Test Mode

Axis Test Mode is only enabled/disabled/configured while offline. The following procedures are the ways to enable/disable Axis Test Mode:

- From the General page of Axis Properties
- From the Motion Group
- From the Tools tab

When Axis Test Mode is enabled, the axis icon in the controller organizer changes.

**Figure 93 - Axis Test Mode Icon**

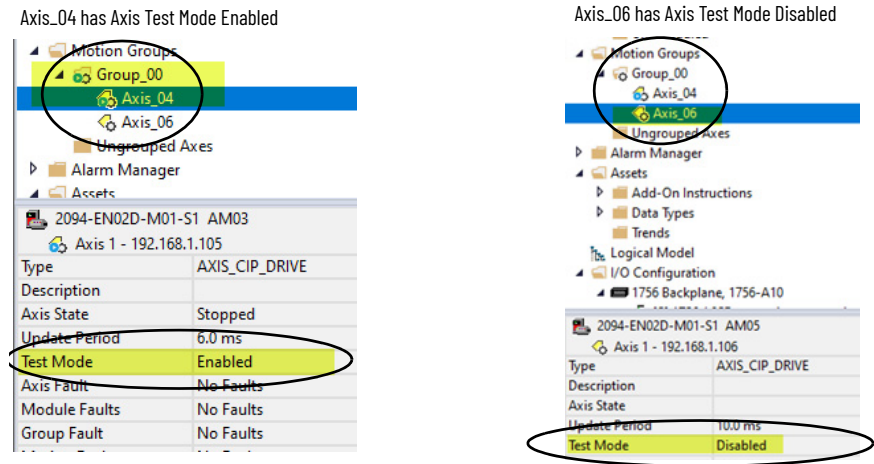

## From the Axis Properties

1. Open the Axis Properties.
2. From the Test Mode Enable dropdown menu, choose Enable or Disable.
3. From the Test Mode Configuration dropdown menu, Controller Loopback is selected.  
Currently, only the Controller Loopback model is supported.

Figure 94 - Axis Properties - Enable Test Mode

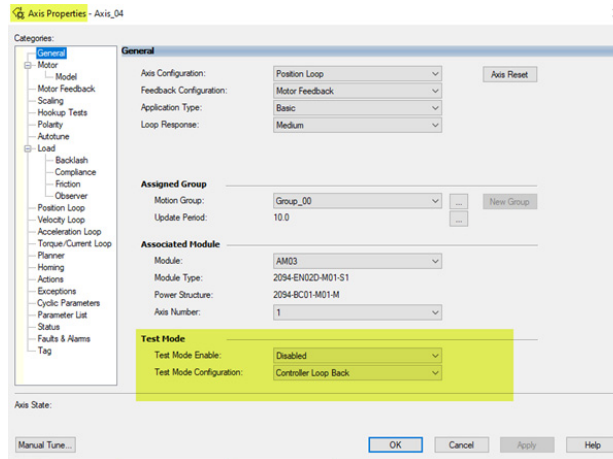

## From the Motion Group

By using this method, you can enable or disable all axes or you can disable individual axes.

1. From the Controller Organizer, right-click the Motion Group and select Motion Test Mode Configuration.
2. In the Axis Test Mode Configuration dialog box, select to Enable All or Disable All axes.  
You can also select to Enable or Disable an individual axis.
3. Select Apply and then OK to save your change.

Figure 95 - Axis Test Mode Enable/Disable from Motion Group

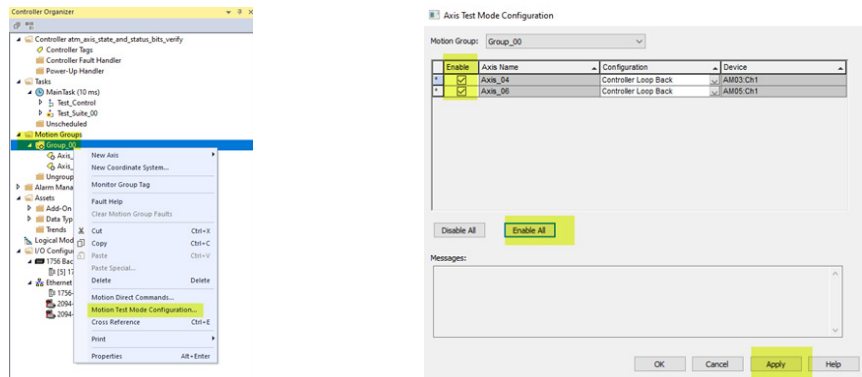

## From the Tools Tab

By using this method, you can enable or disable all axes or you can disable individual axes.

1. Select the Tools tab, select Motion, and select Update Test Mode Configuration.
2. In the Axis Test Mode Configuration dialog box, select to Enable All or Disable All axes. You can also select to Enable or Disable an individual axis.
3. Select Apply and then OK to save your change.

Figure 96 - Axis Test Mode Enable/Disable from Tools Tab

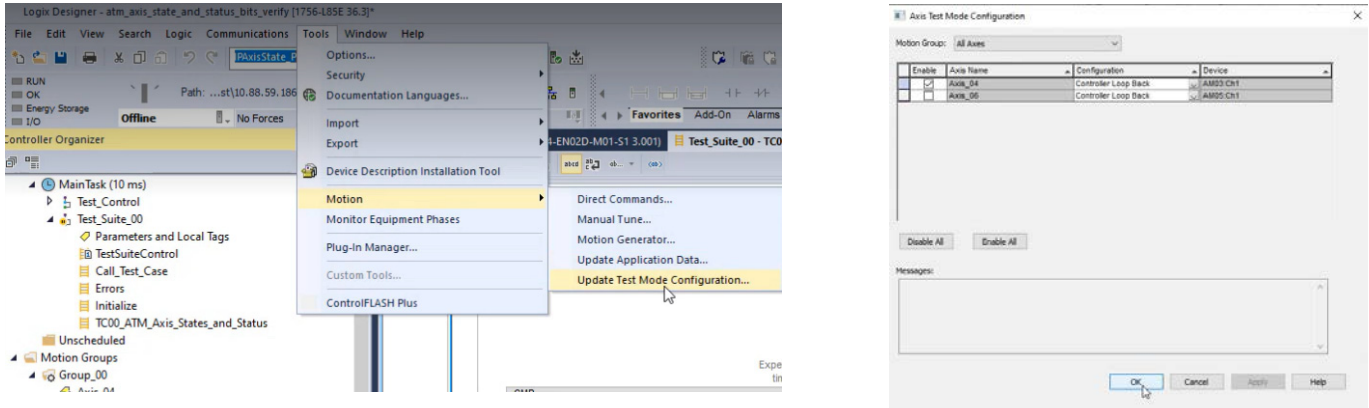

## Axis Simulation

Axis Test Mode simulates axis motion in both standard and safety programs.

For supported instructions and attributes, see the Integrated Motion on the EtherNet/IP Network Reference Manual, publication [MOTION-RM003](#).

## Axis Test Mode Limitations

Instructions that depend on physical input do not always simulate as expected. Evaluate any logic that has these instructions before you enable Axis Test Mode.

- MAH
- MAOC
- MAR
- MDR
- MRAT
- MRHD

Motion Configuration instructions show an error message because the Controller Loopback model does not support tuning or diagnostic tests.

Hookup tests show an error message in the Test State field in the Test Motor and Feedback Device Wiring dialog box for an axis the has Axis Test Mode enabled.

### *Absolute Position Recovery (APR) Considerations*

An axis in Axis Test Mode has no position retention information. If you initiate any of the following actions, the APR position does not restore and the axis start position is reset to 0:

- Download to controller
- Power cycle controller
- Save or restore a project to or from the controller SD card

### Motion Diagnostics

Because there is no physical connection to a CIP drive in Axis Test Mode, no drive diagnostic data is shown and no drive faults are logged.

Figure 97 - Motion Diagnostics when in Axis Test Mode

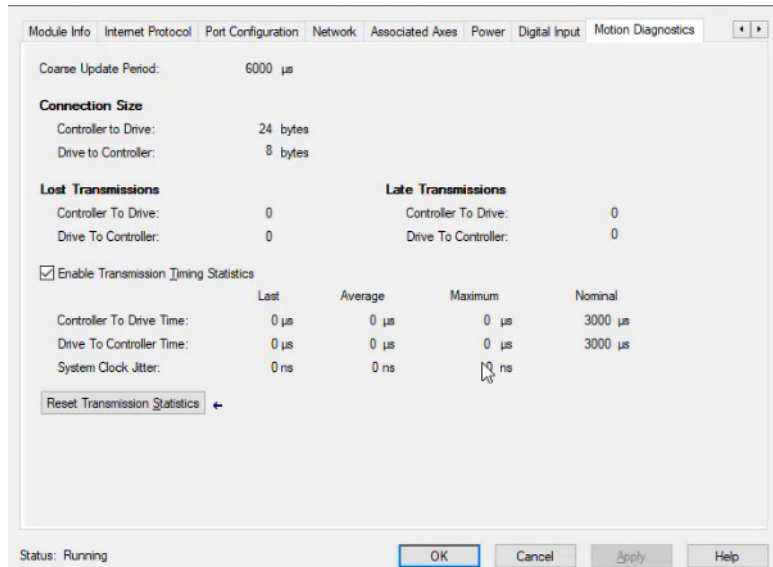

### Cyclic Read/Write

In a physical controller, for every cycle, values are read. In Axis Test Mode, the axis always reports zeros, even if you select parameters to read from or write to the drive.

Axis Test Mode supports two specific cyclic read attributes:

- Safety Data A
- Safety Data B

These pass-thru attributes loopback the values from the simulated safety connection.

Figure 98 - Cyclic Read/Write when in Axis Test Mode

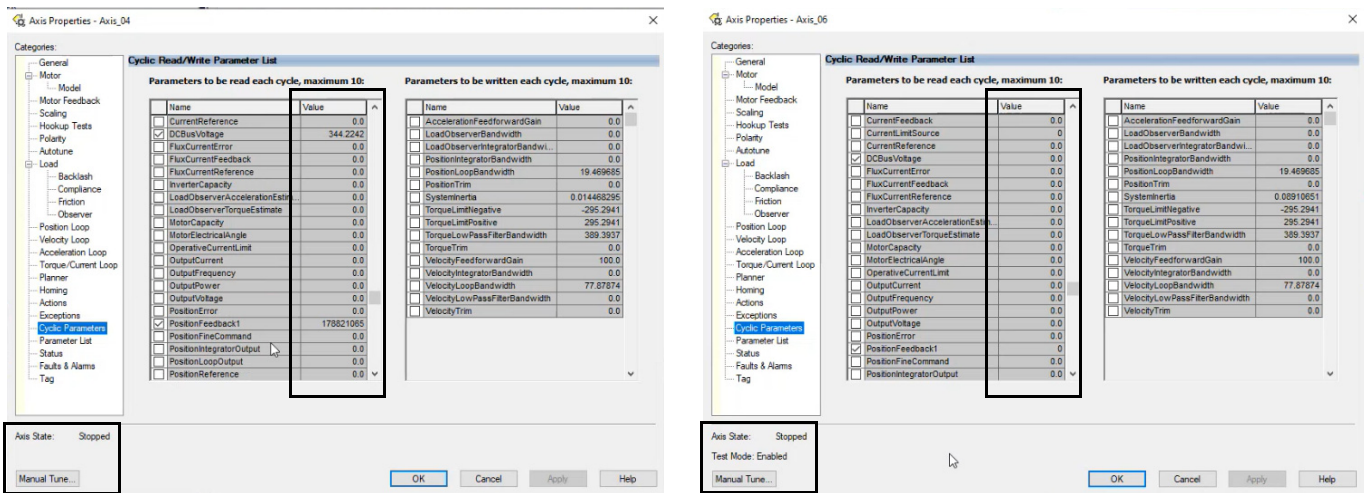

Axis Test Mode Disabled

Axis Test Mode Enabled

## Safety Simulation Considerations

Axis Test Mode operates when a controller is configured for either SIL 2 or SIL 3 safety control. Simulation affects the following safety features:

Safety Feature	Description
Safety signature on a physical controller	In Axis Test Mode on a physical controller, simulation helps prevent the safety controller from generating a safety signature if an axis is in test mode and associated with a CIP Safety drive. A signed project cannot be downloaded to a physical controller if the axes have been switched to Axis Test Mode.
Safety signature on an emulated controller	Axis Test Mode does not help prevent a controller from generating a Safety Signature on an emulated controller. A signed project can be downloaded to an emulated controller for any Axis Test Mode and Safety configuration.
Safety-lock	An application with axes in Axis Test Mode and associated with a Motion and Safety device can be used when an application is safety-locked. The simulation processes safety data and simulates safety functions.

For more information on the safety instructions, see GuardLogix Safety Application Instruction Set reference manual, publication [1756-RM095](#).

## Safe-Torque Off (STO) Considerations

For an axis that has Axis Test Mode enabled, the Safety Inputs simulate the Torque Disabled condition. Axis Test Mode does not support these trigger inputs:

- Safety Limit Fault
- Safety Limit Active
- Connection Loss

When a stop action occurs, the gradual velocity deceleration that is seen on a physical drive is replaced by a sharp drop in Actual Velocity on the axis with Axis Test Mode enabled.

CIP safety drives have an STO bypass function that lets torque be enabled when a motion direct command is executed without the safety task running. Axis Test Mode does not support STO bypass. In Axis Test Mode, an attempt to execute an STO bypass generates an error message.

### *iTRAK Behaviors*

An iTRAK® application in Axis Test Mode supports the STO function. To disable the entire track, each Section Axis must individually request the STO function. With Axis Test Mode enabled, the associated mover axis state remains independent and unaffected by the STO function on the Section Axis.

You need additional logic to simulate physical iTRAK behavior. The Safety Status bits supported with Axis Test Mode include:

- Axis.SafeTorqueOffActiveInhibit
- Axis.SafeTorqueOffActiveStatus
- Axis.SafeTorqueDisabledStatus

## Safe Feedback Interface (SFX) Considerations

The Safe Feedback Interface converts motor velocity and position feedback from a drive module into user scaling units.

Axis Test Mode does not support these attributes:

- Discrepancy Time - (UINT) Attribute 3
- Velocity Ratio - (REAL) Attribute 6
- Velocity Discrepancy Deadband - (REAL) Attribute 7
- Position Discrepancy Deadband - (UDINT) Attribute 10

Axis Test Mode does not support this bit:

- ERS4\_SF\_MSS1:SI.ConnectionFaulted.

## Safe Stop 1 (SS1) Considerations

Safe Stop 1 monitors the deceleration of an axis according to the specified velocity ramp to zero speed and controls its output (O1) to initiate Safe Torque Off (STO). In Axis Test Mode, if you define the Safe Stopping Action Source as Connected Drive, the Axis Velocity Deceleration is not supported.

For an axis that has Axis Test Mode enabled, the Velocity value instantaneously drops to 0. The Axis Test Mode does not support the Ramped Deceleration profile.

SST Features	Axis Test Mode Behavior
SS1 Trigger Sources	'Connection Loss' is not supported because there is no physical connection
SS1 Cold Start Type	Manual is not supported, so when the safety controller mode is set to Run, the SI.RestartRequired is automatically cleared.
Monitored SS1	These configuration parameters are not supported while in Axis Test Mode: <ul style="list-style-type: none"> <li>• Decel Reference Speed</li> <li>• Decel Reference Rate</li> <li>• Decel Speed Tolerance</li> </ul> An axis with Axis Test Mode enabled behaves the same as a physical drive, related faults are not supported.

## Safe Brake Control (SBC) Considerations

The Safe Brake Control function performs these actions:

- Controls safety outputs that actuate a brake.
- Sets timing between brake and torque-off request outputs.
- Monitors brake feedback and I/O status.

Axis Test Mode does not control physical brake outputs and does not simulate these values:

- Brake Feedback 1
- Brake Feedback 2
- Input Status
- Output Status

For an axis that has Axis Test Mode enabled, SBC has these considerations:

SBC Features	Axis Test Mode Behavior
SBC trigger sources	'Connection Loss' is not supported
SBC parameters: Input Configuration	Not supported in Axis Test Mode
SBC parameters: Test Output	Not supported in Axis Test Mode
SBC parameters: Output Configuration	Not supported in Axis Test Mode
SBC mode: Used Test Pulses	'Used, Test Pulses' behavior is similar to 'Used, No Test Pulses'
S01, S00 Safety Outputs S10, S11 Safety Inputs	In Drive Based SBC Function, the Safety outputs S00 and S01 are not supported. Consequently, the feedback from Safety Inputs S10 and S11 is also not supported with Axis Test mode enabled. The SBC Fault Code 101 'Brake Feedback Fault' is not supported.

If STO activates an SBC parameter, an axis with Axis Test Mode enabled supports both options:

- Not Linked: The SBC function acts independently from the STO function.
- Linked: The SBC function is linked to the STO function. When STO is active, after the STO to SBC Delay timer expires, either BrakeEngaged or TorqueDisabled is set.

**Notes:**

## Homing

Homing puts your equipment at a specific starting point for operation. This starting point is called the home position. Typically, you home your equipment when you reset it for operation.

When using integrated motion on the EtherNet/IP™ network, all active and passive homes are setting absolute positions as long as an absolute device is being used.

The controller loopback configuration in the Axis Test Mode only supports the Home Immediate and Home Immediate Absolute motion sequencing. Additional Homing Sequences, like Home to Switch and Home to Marker, are not supported. You must add your own logic to bypass the unsupported sequences.

See the Integrated Motion on the EtherNet/IP network Reference Manual, publication [MOTION-RM003](#), for more details about the Homing attributes.

### Guidelines for Homing

To configure the homing procedure, you specify the mode (active or passive) and sequence. Based on those selections, you can also choose the home position, an offset for the home position, the direction, and speed. For switch-based sequences, you can also select whether the limit switch is normally open or normally closed.

[Table 42](#) describes guidelines for homing procedures.

**Table 42 - Guidelines for the Homing Procedures**

Guideline	Description
To move an axis to the home position, use Active homing.	Active homing turns on the servo loop and moves the axis to the home position. Active homing also does the following: <ul style="list-style-type: none"> <li>Stops any other motion.</li> <li>Uses a trapezoidal profile.</li> </ul>
<b>For a Feedback-only device, use Passive homing.</b>	Passive homing does not move the axis: <ul style="list-style-type: none"> <li>Use passive homing to calibrate a Feedback-only axis to its marker.</li> <li>If you use passive homing on a servo axis, turn on the servo loop and use a move instruction to move the axis.</li> </ul>
For single-turn equipment, consider homing to a marker.	The marker homing sequence is useful for single-turn rotary and linear encoder applications because these applications have only one encoder marker for full axis travel.
For multi-turn equipment, home to a switch or switch and marker.	These homing sequences use a home limit switch to define the home position: <ul style="list-style-type: none"> <li>You need a home limit switch if the axis moves multiple revolutions when it runs. Otherwise, the controller cannot tell which marker pulse to use.</li> <li>For the most precise homing, use both the switch and marker.</li> </ul>
If your equipment can't back up, use unidirectional homing.	With unidirectional homing, the axis doesn't reverse direction to move to the Home Position. For greater accuracy, consider using an offset: <ul style="list-style-type: none"> <li>Use a Home Offset that is in the same direction as the Home Direction.</li> <li>Use a Home Offset that is greater than the deceleration distance.</li> <li>If the Home Offset is less than the deceleration distance does the following: <ul style="list-style-type: none"> <li>The axis simply slows to a stop. The axis doesn't reverse direction to move to the Home Position. In this case, the MAH instruction doesn't set the process compete bit.</li> <li>On a rotary axis, the controller adds one or more revolutions to the move distance. This addition makes sure that the move to the Home Position is unidirectional.</li> </ul> </li> </ul>
Choose a starting direction for the homing sequence.	Decide which direction you want to start the homing sequence in: <ul style="list-style-type: none"> <li>Positive direction—choose a Forward direction.</li> <li>Negative direction—choose a Negative direction.</li> </ul>

## Active Homing

When the axis Homing mode is configured as Active, the physical axis is first activated for servo operation. As part of this process, all other motion in process is canceled and appropriate status bits cleared. The axis is then homed by using the configured Home Sequence, which can be Immediate, Switch, Marker, or Switch-Marker. The latter three Home Sequences result in the axis being jogged in the configured Home direction. Then, after the homing sequence is complete, the position is redefined. Based on detection of the home event, the axis is automatically moved to the configured Home Position.

---

**IMPORTANT** The control moves the axis to the unwind position of zero. This movement occurs only when unidirectional active homing is performed on a rotary axis and the Home Offset value is less than the deceleration distance when the home event is detected. This process helps make sure that the resulting move to the Home Position is unidirectional.

---

## Passive Homing

When the axis Homing mode is configured as Passive, the MAH instruction redefines the actual position of a physical axis on the next occurrence of the encoder marker or home sensor. The sequence determines the homing steps. You must set the homing sequence to marker or switch. Passive homing is most commonly used to calibrate Feedback Only axes to their markers or switch. Passive homing is identical to active homing to an encoder marker or switch except that the motion controller does not command any axis motion.

After initiating passive homing (MAH), the axis must be moved past the encoder marker or trip the home switch for the homing sequence to complete properly. In this case, you must set the homing sequence to marker or switch. The motion controller cannot directly command motion for physical Feedback Only axes and must be accomplished via other means.

For closed-loop Servo axes, when configured for Passive Homing, only set the Sequence to Immediate. Then when the MAH is executed, it simply sets the actual position to that of the Position value set in the Homing parameters. There is no physical motion with these settings.

## Examples

This section contains examples of active and passive homing.

### Active Homing

The examples in [Table 43](#) show different ways to use active homing.

**Table 43 - Active Homing Examples**

Sequence	Description
<b>Active immediate home</b>	This sequence sets the axis position to the Home Position without moving the axis. If feedback isn't enabled, this sequence enables feedback.
<b>Active immediate Absolute</b>	As with the Active Immediate Home, when this sequence is performed, the controller immediately enables the drive, but rather than assigning a user-configurable Home Position to the current axis actual position and command position, the controller sets actual position and command position to the current position of the absolute feedback device. This homing sequence produces no axis motion. Unlike Active Immediate Home, the Home Offset attribute in this case is applicable.
<b>Active home to switch in forward Bidirectional</b>	<p>The switch homing sequence is useful for multi-turn rotary and linear applications.</p> <div style="text-align: center;"> <p>Active Bidirectional Home with Switch then Marker</p> <p>1: Home Limit Switch Detected 2: Home Limit Switch Cleared 3: Home Position</p> </div> <p>These steps occur during the sequence.</p> <ol style="list-style-type: none"> <li>1. The axis moves in the Home Direction at the Home Speed to the home limit switch and stops.</li> <li>2. The axis reverses direction and moves at the Home Return Speed until it clears the home limit switch and then stops.</li> <li>3. The axis moves back to the home limit switch or it moves to the Offset position. The axis moves at the Home Return Speed. If the axis is a Cyclic Travel Mode Axis, the move back to the Home Position takes the shortest path (that is, no more than a half revolution).</li> </ol> <p>If the axis is past the home limit switch at the start of the homing sequence, the axis reverses direction and starts the return leg of the homing sequence.</p> <p>Use a Home Return Speed that is slower than the Home Speed to increase the homing accuracy. The accuracy of this sequence depends on the return speed and the delay to detect the transition of the home limit switch.</p> <p>Uncertainty = Home Return Speed x delay to detect the home limit switch.</p> <p><b>Example:</b> Suppose that your Home Return Speed is 0.1 in./s and it takes 10 ms to detect the home limit switch. Uncertainty = 0.1 in./s x 0.01 s = 0.001 in.</p> <p>The mechanical uncertainty of the home limit switch also affects the homing accuracy.</p>

Table 43 - Active Homing Examples (Continued)

Sequence	Description
<p><b>Active home to marker in forward Bidirectional</b></p>	<p>The marker homing sequence is useful for single-turn rotary and linear encoder applications because these applications have one encoder marker only for full axis travel.</p> <p style="text-align: center;">Active Bidirectional Home with Marker</p>  <p>These steps occur during the sequence.</p> <ol style="list-style-type: none"> <li>1. The axis moves in the Home Direction at the Home Speed to the marker and stops.</li> <li>2. The axis moves back to the marker or it moves to the Offset position. The axis moves at the Home Return Speed. If the axis is a Cyclic Travel Mode Axis, the move back to the Home Position takes the shortest path (that is, no more than a half revolution).</li> </ol> <p>The accuracy of this homing sequence depends on the homing speed and the delay to detect the marker transition.          Uncertainty = Home Speed x delay to detect the marker.  <b>Example:</b> Suppose that your Home Speed is 1 in./s and it takes 1 m s to detect the marker.          Uncertainty = 1 In./s x 0.000001 s = 0.000001 in.</p>
<p><b>Active home to switch and marker in forward Bidirectional</b></p>	<p>This sequence is the most precise active homing sequence available.</p> <p style="text-align: center;">Active Bidirectional Home with Switch then Marker</p>  <p>These steps occur during the sequence.</p> <ol style="list-style-type: none"> <li>1. The axis moves in the Home Direction at the Home Speed to the home limit switch and stops.</li> <li>2. The axis reverses direction and moves at the Home Return Speed until it clears the home limit switch.</li> <li>3. The axis continues to move at the Home Return Speed until it gets to the marker.</li> <li>4. The axis moves back to the marker or it moves to the Offset position. The axis moves at the Home Return Speed. If the axis is a Cyclic Travel Mode Axis, the move back to the Home Position takes the shortest path (that is, no more than 1/2 revolution).</li> </ol> <p>If the axis is past the home limit switch at the start of the homing sequence, the axis reverses direction and starts the return leg of the homing sequence.</p>

Table 43 - Active Homing Examples (Continued)

Sequence	Description
<b>Active home to switch in forward unidirectional</b>	This active homing sequence is useful for when an encoder marker is not available and either unidirectional motion is required or a proximity switch is being used. These steps occur during the sequence. <ol style="list-style-type: none"> <li>1. The axis moves in the Home Direction at the Home Speed to the home limit switch.</li> <li>2. If it's in the same direction as the Home Direction, the axis moves to the Home Offset position.</li> </ol>
<b>Active home to marker in forward unidirectional</b>	This active homing sequence is useful for single-turn rotary and linear encoder applications when unidirectional motion is required. These steps occur during the sequence. <ol style="list-style-type: none"> <li>1. The axis moves in the Home Direction at the Home Speed to the marker.</li> <li>2. If it's in the same direction as the Home Direction, the axis moves to the Home Offset position.</li> </ol>
<b>Active home to switch and marker in forward unidirectional</b>	This active homing sequence is useful for multi-turn rotary applications when unidirectional motion is required. These steps occur during the sequence. <ol style="list-style-type: none"> <li>1. The axis moves in the Home Direction at the Home Speed to the home limit switch.</li> <li>2. The axis continues to move at the Home Speed until it gets to the marker.</li> <li>3. If it's in the same direction as the Home Direction, the axis moves to the Home Offset position.</li> </ol>

## Passive Homing

The examples in [Table 44](#) show different ways to use passive homing.

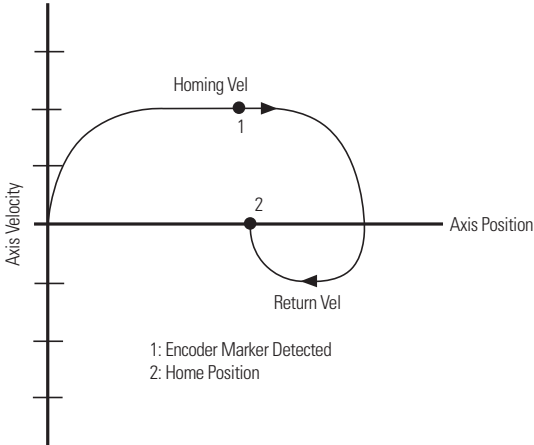
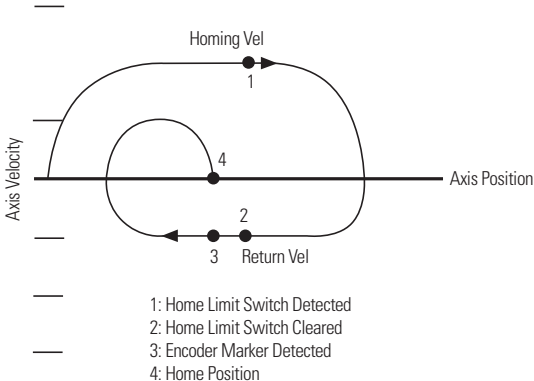
Table 44 - Passive Homing Examples

Sequence	Description
Passive Immediate Home	This sequence is the simplest passive homing sequence type. When this sequence is performed, the controller immediately assigns the Home Position to the current axis actual-position. This homing sequence produces no axis motion.
Passive Immediate Absolute	When this sequence is performed, rather than assigning a user-configurable Home Position to the current actual axis position, the controller immediately sets the actual position to the current position of the absolute feedback device. This homing sequence produces no axis motion. Unlike Active Immediate Home, the Home Offset attribute in this case is applicable.
Passive Home with Switch	This passive homing sequence is useful for when an encoder marker is not available or a proximity switch is being used. When this sequence is performed in the Passive Homing mode, an external agent moves the axis until the home switch is detected. The Home Position is assigned to the axis position at the moment that the limit switch is detected. If you are using a Home Offset, then the Home Position is offset from the point where this value detects the switch.
Passive Home with Marker	This passive homing sequence is useful for single-turn rotary and linear encoder applications. When this sequence is performed in the Passive Homing mode, an external agent moves the axis until the marker is detected. The home position is assigned to the axis position at the precise position where the marker was detected. If you are using a Home Offset, then the Home Position is offset from the point where this value detects the marker.
Passive Home with Switch then Marker	This passive homing sequence is useful for multi-turn rotary applications. When this sequence is performed in the Passive Homing mode, an external agent moves the axis until the home switch and then the first encoder marker is detected. The home position is assigned to the axis position at the precise position where the marker was detected. If you are using a Home Offset, then the Home Position is offset from the point where this value detects the marker.

## Absolute Position Recovery (APR)

APR is the recovery of the absolute position of an axis that has been machine-referenced after a power cycle or reconnection. The APR feature maintains the machine reference or absolute position through power cycles, program downloads, and even firmware updates under certain conditions. The terms Absolute Position and Machine Reference Position are synonymous.

Absolute position is established by a homing procedure that is initiated by successful execution of an MAH instruction. Once the homing procedure has successfully established a machine reference, the Axis Homed bit is set in the Motion Status attribute, indicating that actual position and command position now have meaning regarding the associated machine.

If the Axis Homed status bit is clear, the APR function is bypassed and there is no attempt to restore absolute position. The clear status bit indicates that position has not been absolutely referenced to the machine.

If the Axis Test Mode feature is enabled, then the APR function is bypassed. Axis Test Mode cannot interfere with the application of homing and APR made outside of Axis Test Mode.

After a power cycle, disabling Axis Test Mode, or a project download, the controller sets the axis start position at 0.

The axis moves to a specific position and cannot have any relationship to the position of the axis on the actual machine if all axes in the machine have not been homed before the operation. Any time the Axis Homed status bit is cleared, the axis must be homed.

## APR Terminology

[Table 45](#) describes terminology that is related to the APR feature.

**Table 45 - APR Terminology Descriptions**

Term	Description
Absolute Feedback Position	Position value that is read from an absolute feedback device.
Incremental Feedback Position	Position value that is read from an incremental feedback device.
Feedback Position	Value that is read from a feedback device, absolute, or incremental.
Absolute Position Absolute Machine Reference Position Machine Reference Position	Position registers in the Logix 5000™ controllers after the following instructions have been executed on a machine with an absolute or an incremental feedback device: <ul style="list-style-type: none"> <li>• MAH, machine home</li> <li>• MRP, machine redefine position</li> </ul>
A machine home/reference	Establishes a Machine Reference Offset as follows: $\text{HomeOffset} = \text{ConfiguredHomePosition} - \text{AbsoluteFeedbackPosition}$ $\text{AbsoluteMachineReferencePosition} = \text{AbsoluteFeedbackPosition} + \text{HomeOffset}$
Absolute Position Recovery (APR)	Recovers the Absolute Machine Reference Position by maintaining the Home Offset through various scenarios as described on <a href="#">page 160</a> .

## Position Recovery Considerations for Logix 5000 Controllers

There are differences in the way the ControlLogix® 5560, GuardLogix® 5560, and the ControlLogix 5570 controllers recover machine position:

- The ControlLogix 5560 and GuardLogix 5560 controllers have a battery and use a memory card to save information.
- The ControlLogix 5570 controller has a 1756-ESMxxx module and uses a memory card to save information.
- The ControlLogix 5560 and GuardLogix 5560 series A controllers have a battery to recover the position after a power cycle but does not support APR.
- The ControlLogix 5560 and GuardLogix 5560 series B controllers recover the position after a download or restore from the ControlFLASH™ software card or a firmware update from the ControlFLASH software. A battery is not required.
- The ControlLogix 5570 controller with a ControlLogix Controller Energy Storage Module (ESM) works the same as the GuardLogix 5560 series B controller with a battery.
- The ControlLogix 5570 controller without a ControlLogix Controller Energy Storage Module (ESM) works like a ControlLogix 5560 series B controller without a battery.

## Absolute Feedback Device

The absolute feedback device permits the absolute position to be retained through a power cycle. These devices take various forms, but they can all maintain an absolute feedback position while power to the drive and feedback device is off.

When power is turned back on, the drive reads the feedback referenced absolute position from the feedback device. By applying a saved absolute offset to this absolute feedback position, the motion control system can recover the machine referenced absolute position.

Most drive products provide this capability. However, Absolute Position is lost if the drive is swapped out or the drive firmware is updated. Integrated motion on the EtherNet/IP network lets you recover Absolute Position through power cycles, program downloads, and firmware updates.

## SERCOS Versus Integrated Motion on Ethernet Networks

For a SERCOS axis with absolute feedback, the drive scaling function and absolute position are maintained in the drive. Therefore, the drive scaling function and absolute position can be easily restored in the control after a power cycle or download of a new project. This restoration is accomplished by reading the position from the drive.

By contrast, an integrated motion on the EtherNet/IP network axis supports controller-based scaling where absolute position is maintained in the firmware of the controller. Without the work of the APR feature, absolute position would be lost after a power cycle or project download.

### APR Scenarios



**ATTENTION:** Whenever memory becomes corrupt, you lose position even if you have it stored on a memory card.

---

[Table 46 on page 162](#) provides detailed information on when the APR feature recovers absolute position. The following assumptions must be considered. In each of these cases, the APR feature restores absolute position and preserves the state of the Axis Homed bit. This feature indicates that the axis has a machine referenced absolute position.

- All relevant axes are integrated motion axes.
- Yes, indicates that machine reference is recovered (for Axes that have been homed).
- No, indicates that machine reference is not recovered (for Axes that have been homed).

[Table 46](#) describes the scenarios whether the APR feature recovers absolute position. In each case that is marked Yes, the APR feature restores absolute position and preserves the state of the Axis Homed bit. This mark indicates that the axis has a machine referenced absolute position.

Table 46 - APR Recovery Scenarios

Scenario	Event	Machine Reference Retained
<b>Controller</b>	Battery <sup>(1)</sup>	Yes
	Controller power cycle with battery. <sup>(1)</sup>	Yes
	Controller removal and insertion under power (RIUP) with a battery <sup>(1)</sup> .	Yes
	Controller firmware update.	Yes
	Controller update from Secure Digital card.	Yes
	Swap two controllers with the same catalog numbers (Secure Digital card also swapped). It is only possible to restore the APR from a Secure Digital card if the second controller had a previously homed application.	Yes
	Steps 1. Axes are homed. 2. Project is saved to Secure Digital card. 3. Axes are moved and re-referenced. 4. System is restored from Secure Digital card. Result The system absolute position is restored to re-referenced positions and the Home bit remains set.	Yes
	The system absolute position on each machine becomes restored correctly at its respective position and the Home bit remains set.	Yes
	Change controller (Secure Digital card not swapped).	No <sup>(2)</sup>
	Change controller without a Secure Digital card.	No
	Controller CompactFlash update.	Yes
	Controller swap (same CF card).	Yes
	Change controller.	No
	Change controller without a CompactFlash card.	No
	Controller power cycle without battery. <sup>(1)</sup>	No <sup>(3)</sup>
	Controller removal and insertion under power (RIUP) without battery. <sup>(1)</sup>	No
	Take the controllers out of two systems with a battery or energy storage module and swap controller. There are no CompactFlash or Secure Digital card on either controller.	No
	1. Controller remains powered. 2. Power cycle drives. 3. Change feedback device type but not motor.	No <sup>(3)</sup>
	Axes are homed. The system absolute position is lost, the axes must be rehomed, and the Home bit is cleared.	No <sup>(3)</sup>
	Controller power cycle or removal and insertion under power without a battery or energy storage module.	No
1. Controller and drives remained powered. 2. Hardware feedback failure on an axis.	No	
Battery backed controller. User program running with an axis that is not homed.	No	
<b>Controller and drives remained powered</b>	Disconnect and reconnect the Ethernet cable.	Yes
	Disconnect and reconnect the same feedback or motor cable on an axis.	Yes
	Inhibit or uninhibit an axis or drive.	Yes

Table 46 - APR Recovery Scenarios (Continued)

Scenario	Event	Machine Reference Retained
<b>Battery backed controller</b>	Save to a Secure Digital card <sup>(2)</sup> with a homed axis and you initiate the restore.	Yes
	RIUP controller.	Yes
	Cycle power-on controller.	Yes
	Cycle power-on controller that is configured to restore the user program from a Secure Digital card on power-up.	Yes
	RAM memory becomes corrupt and the user program is restored from the Secure Digital card. The machine must be referenced again because RAM memory is corrupt. There is no way to retrieve the machine reference positions from a memory card after machine memory becomes corrupt.	No <sup>(3)</sup>
	User program that runs with a homed axis and you manually restore the user program from a Secure Digital card. If you reset the machine reference by using MAH or MRP after storing the user program to a memory card, the MAH and MRP changes are not lost. The APR is not restored to the reference stored on the memory card. The APR is restored to the reference stored in RAM.	Yes
	Battery backed controller: Restore by taking the Secure Digital card to another controller. If the other controller has the exact same Axis ID and scaling constants as the Secure Digital card, and has homed axes, the APR is not restored to the reference stored on the card. The APR is restored to the reference stored in RAM. The Axis ID attribute is automatically generated when you create an axis in the Logix Designer application. See The Axis ID attribute description in the Integrated Motion on the EtherNet/IP network Reference Manual, publication <a href="#">MOTION-RM003</a> for more information.	Yes
<b>Change controller</b>	Transfer the Secure Digital card from the first controller to the second with the following preconditions. 1. Empty the second controller. There is no user program in the second controller. 2. The user program has been saved on a Secure Digital card with CIP Motion axes homed.	No
	Transfer the Secure Digital card from the first controller to the second with the following preconditions. 1. The second controller has the same user program with the controller being swapped. 2. The second controller has axes homed.	Yes
<b>Same controller</b>	Reload the same user program from a Secure Digital card. This scenario assumes that the axis is homed in RAM before reload.	Yes
	Update controller firmware from Secure Digital card.	Yes
<b>Controller remains powered or power cycled with battery and power cycle drives</b>	Change the drive with the same or different catalog number.	Yes
	Change the motor but not the feedback device.	Yes
<b>Download same program with no hardware changes</b>	Change the name of an axis.	Yes
	Download the same Studio 5000 Logix Designer application program to the controller.	Yes
	Save As with another filename.	Yes
	Partial Export and then import an axis.	Yes
	Added application logic.	Yes
	Download the Studio 5000 Logix Designer project of an existing axis.	Yes
	Add an axis.	No for the new axis.
	Copy or cut and paste or drag then drop axis into the same project or another project.	No for the new or pasted axis.
	Export and then import into the same or another project. <b>Tip:</b> Save the project as an .ACD file to recover the absolute position.	No
There are changes to the axis scaling attributes.	No	
<b>Position feedback</b>	The position feedback device was disconnected or reconnected.	Yes

Table 46 - APR Recovery Scenarios (Continued)

Scenario	Event	Machine Reference Retained
<b>Feedback device</b>	The position feedback device was disconnected or reconnected.	Yes
	The feedback device type changed.	No <sup>(3)</sup>
	The position feedback device was swapped.	No <sup>(3)</sup>
	The position feedback device failed.	No <sup>(3)</sup>
	The position feedback polarity changed.	No <sup>(3)</sup>
	The feedback mode changed.	No <sup>(3)</sup>
<b>Restore</b>	Restore from Secure Digital card. (It is only possible to restore the APR from a Secure Digital card if the controller had a previously homed application.)	Yes
<b>Inhibit or Uninhibit</b>	Inhibit or uninhibit an axis.	Yes
	Inhibit or uninhibit an I/O module.	Yes
<b>Axis Unassigned or Assigned to Motion Group</b>	Axis assigned to a motion group.	Yes
	Axis unassigned to a motion group.	Yes
<b>Axis Unassociated or Associated to Motion Device</b>	Axis associated to a motion device.	Yes
	Axis unassociated to a motion device.	Yes
<b>Studio 5000 Logix Designer application project</b>	Import or export the project download.	Yes
	Download the project download of new or copied axis.	No <sup>(4)</sup>
<b>Drive</b>	The drive cycled power with incremental feedback.	No
	The drive firmware updated with incremental feedback.	No
	Change the drive.	Yes
	Cycle power to the drive.	Yes
	Cycle power to the drive with absolute feedback.	Yes
	Change the motor, if the motor does not contain a feedback device.	Yes
	The drive firmware was update with absolute feedback.	Yes
	The drive was disconnected or reconnected.	Yes
	The drive was inhibited or uninhibited.	Yes
The drive was swapped with the same feedback.	Yes	
<b>Scaling</b>	Scaling signature has changed. The scaling signature changed. This change includes Transmission, Linear Actuator, Motion Resolution, and Motion Unit attribute changes.	No <sup>(3)</sup>

(1) The term Battery in this table assumes the ControlLogix 5560 or GuardLogix 5560 controller with a battery or a ControlLogix 5570 controller and a 1756-ESMxxx Energy Storage Module.

ControlLogix 5580, GuardLogix 5580, CompactLogix™ 5380, and Compact GuardLogix 5380 controllers have embedded energy storage modules.

(2) The controller cannot generate the fault because the data cannot be preserved.

(3) When any of these conditions occur, the Axis Homed bit, if set, is cleared indicating that axis position is no longer referenced to the machine. To flag the condition that the Axis Homed bit has been cleared and that the machine referenced absolute position has been lost, an APR Fault is generated. This fault is recoverable and can be cleared via any Fault Reset or Shutdown Reset instruction.

(4) Not retained for the new or copied axis.

## APR Faults

An APR fault is generated when the system fails to recover the absolute position of the axis after power cycle, reset, or reconnection. When an APR fault occurs, the actual position of the axis is no longer correlated to the position of the axis before the power cycle, reset, or reconnect. APR Faults can be generated during initial axis configuration or during operation. APR faults are recoverable and can be cleared with a Fault Reset request. See [Resetting an APR Fault on page 168](#).

### APR Fault Conditions

The axis must be in the homed state, with the Axis Homed bit set, for an APR Fault to occur.

#### Attribute Changes

A Motion Resolution or an Axis Feedback Polarity attribute has been changed and downloaded to the controller. This change can also happen during the execution of an SSV.

### *Axis Feedback Changes*

The feedback device has been replaced. This change creates an Axis Feedback Serial Number mismatch APR fault.

Axis Feedback mode has changed, for example, axis with feedback changed to axis without feedback or vice versa and downloaded to the controller.

- A user program is downloaded.
- A user program and tags are restored from the memory card.
  - Manual Restore
  - Power-up restore, when configured
- Firmware is updated via ControlFLASH™ software.
- An SSV to either change Feedback Polarity or one of the attributes, which results in a change to the Motion Resolution attribute.

### **APR Fault Generation**

A project download, restore from a memory card, or a ControlFLASH firmware update after one of these events can cause an APR fault:

- Axis configuration.
  - Change in any of the axis attributes that impact the absolute machine position.
- Attribute changes.
  - Offline edits of the axis attributes or configuration do not cause an APR fault until after the download occurs.
  - Online edits of certain attributes result in an immediate APR fault. Changing the axis feedback device or feedback polarity without downloading the project also generates an immediate APR fault.
- Axis hardware change or malfunction.
- Axis hardware resource insufficiency.
  - Hardware resource insufficiencies are detected only during download or ControlFLASH firmware update.
- Reconnection of the drive axis.

When an APR fault occurs, the actual position of the axis is set to the feedback reference position of the axis. This value is read from the absolute encoder of the axis. The APR Fault clears the axis homed status bit.

### *APR Download Checks*

The following checks are made during a download of a project:

1. Does the Axis exist? If not, then it is a new axis and no APR fault occurs or is generated.
2. Does the Scaling Signature match the saved Scaling Signature?
3. Does the Feedback Serial Number match the saved Feedback Serial Number?
4. Does the Mover Axis Assignment Sequence match the saved Mover Axis Assignment Sequence?

If these checks pass, absolute position is restored.

### *APR Monitoring During Operation*

During operation, the system monitors the following conditions:

1. Is the Feedback Integrity Status bit cleared?
2. Were Scaling Signature dependent attribute values changed by using an SSV instruction?

If any of these conditions occur, an APR Fault is generated and the Homed Status bit is cleared. In the case of a cleared Feedback Integrity bit, there still is an opportunity to restore absolute position if an absolute position feedback device is used. If on a subsequent Fault Reset, the system finds that the Feedback Integrity bit is set, the APR function restores absolute position and the Homed Status bit.

Similarly, if on a subsequent drive power cycle or drive disconnect/reconnect, the system finds that the Feedback Integrity bit is set, the Feedback Integrity Loss Fault is cleared and the APR function restores absolute position and the Homed Status bit. However, absolute position is not restored, and the Homed Status bit remains clear when connected to an incremental feedback device, necessitating re-execution of the axis homing procedure.

These attributes do not affect the Scaling Signature or result in the loss of the absolute machine reference and therefore do not generate an APR Fault.

- Conversion Constant
- Position Unwind
- Travel Mode

Care must be taken when changing these values so that the new values are correctly related to the Position Unit of the product and the mechanics of the system. This correlation is typically done as part of a product recipe change. For example, when you are wrapping regular sized candy bars and then you must change and make king size bars, you would change the conversion constant.

If the Axis Homed status bit is clear, the APR function is bypassed and there is no attempt to restore absolute position. The clear status bit indicates that position has not been absolutely referenced to the machine.

### *Types of APR Faults*

There are two types of APR Faults: Standard APR Faults and Rockwell Automation Specific Faults. APR Faults display in the Axis Properties dialog box, Faults and Alarms.

**Table 47 - Standard APR Fault Descriptions (Attribute 756)**

Value	Exception	Description
1	Memory Write Error	Error in saving absolute position data to nonvolatile memory.
2	Memory Read Error	Error in reading absolute position data from nonvolatile memory.
3	Feedback Serial Number Mismatch	Position Feedback Serial Number does not match the saved Feedback Serial Number.
4	Buffer Allocation Fault	Caused when there is not enough RAM memory left to save APR data.
5	Scaling Configuration Changed	Scaling attribute configuration for this axis does not match the saved scaling configuration.
6	Feedback Mode Change	Feedback Mode has changed and does not match the saved Feedback Mode configuration.

**Table 48 - Rockwell Automation Specific Fault Descriptions (Attribute 905)**

Value	Exception	Description
1	Persistent Media Fault	After you get this fault, the APR feature stops working until you replace the ControlLogix 5560 or GuardLogix 5560 controller.
2	Firmware Error	Used to trap unexpected firmware errors.

## APR Fault Examples

### Scaling

Scaling parameters changes can potentially generate an APR fault because internal constants computed from these two parameters can generate a motion resolution change. If this change happens, an APR fault is generated.

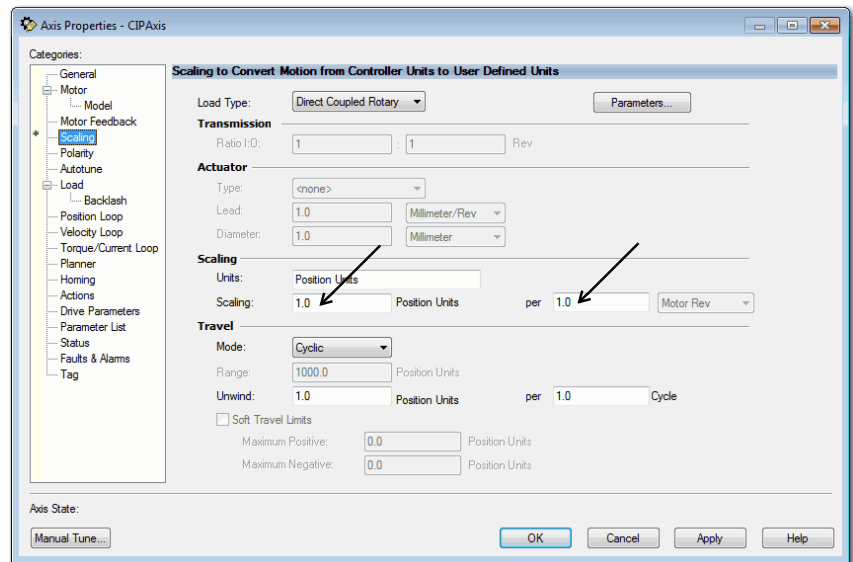

### Online Scaling

Any change or SSV message that results in a motion resolution change can generate an APR fault.

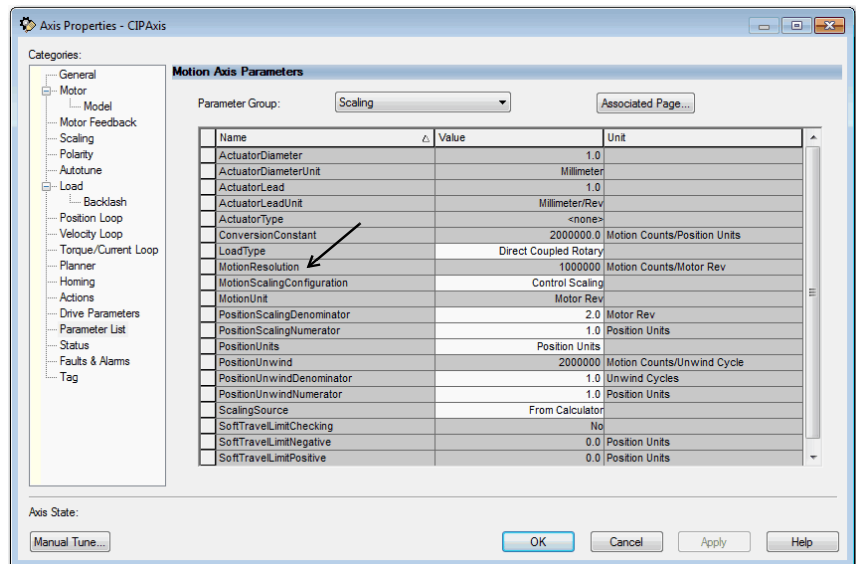

### Saving an ACD File Versus Upload of a Project

The following is an example of a sequence of events that can generate an APR fault.

1. Make an online change to an axis attribute that generates an APR fault.
2. Rehome the axis.  
This action is normally done so APR restores axes positions after a download.
3. Save your project.

## 4. Download your project.

You still get an APR fault because saving the project only uploads the tags, not the changed attributes.

---

**IMPORTANT** You must upload the project for the changed attributes to be saved and to help prevent an APR fault on a subsequent download.

---

## Resetting an APR Fault

There are three ways to reset an APR Fault:

- Execute an Instruction:
  - Motion Axis Fault Reset (MAFR)
  - Motion Group Shutdown Reset (MGSR)
  - Motion Axis Shutdown Reset (MASR)
  - Motion Coordinated Shutdown Reset (MCSR)
- Do the following from the Controller Organizer:
  - Clear the group fault, the software executes an MGSR
  - Clear the axis fault, the software executes an MASR
- Download the same project a second time



For iTRAK systems, if a Feedback Integrity Loss APR fault occurs, you must manually execute an MAFR command to clear the fault.

The fault will not be cleared with a redownload or power cycling the track.

## Absolute Position Loss without APR Faults

The Absolute Position Recovery is not retained after the following:

- A project is exported, saved as an .L5K, and imported (downloaded)
- A major nonrecoverable fault (MNRF)
- A power loss



When you perform an import/export on a project in the RSLogix 5000® software, version 19 or earlier, the axis absolute position is not recovered on download to the controller.

The APR can potentially be restored from a memory card on a ControlLogix 5560 or GuardLogix 5560 controller (if a battery is not present) or on a ControlLogix 5570 controller (if a 1756-ESMxxx module is not present) as described on [page 160](#).

- A download of an axis that does not have its home bit set
- Power cycling of an incremental encoder

## Behavior of APR for Incremental Encoders

APR for incremental encoders means Absolute Machine Reference Position Retention. When an incremental encoder is homed, the homed bit is set. An APR fault is generated and the home axis bit clears when any of the events or conditions that generate an APR fault for an absolute encoder occur.

For example, the behavior of APR faults for an incremental encoder is identical to that of an absolute encoder. The exception to this behavior is when an incremental encoder is power cycled and its position comes up as zero. Its Absolute Machine Reference Position is lost. An APR fault is not generated.

## Manual Tune

Manual tuning lets you customize your tuning parameters. It also lets you manually improve motion performance by adjusting system bandwidth, damping factor, and drive loop gains, filters, and compensations via direct online control. Perform a manual tune when you are online with a controller to tune an axis in real time.

### When to Manually Tune an Axis

If you are not sure if you need to manually tune, use this process:

- If the software calculation defaults are acceptable, tuning is complete.
- If the software calculation defaults are not acceptable, and tuning-less features are available for your drive, configure the drive for tuning-less operation, otherwise, perform an Autotune. If the results are acceptable, tuning is complete.
  - See the Tuning-less Feature Configuration Quick Start Guide, publication [MOTION-QS001](#). See [Autotune on page 131](#) for details.
- If the results are not acceptable, manually tune the axis.

### Axis Configuration Types

Manual Tune applies to Position Loop and Velocity Loop axis configurations. Manual Tune is not available for any other axis configurations. If you change the axis configuration to a value other than Position Loop or Velocity Loop while Manual Tune is opened, the contents of the Manual Tune expander becomes disabled. This condition also applies to the Additional Tune functions.

### Current Tuning Configuration

Manual Tune displays the current tuning configuration. All parameters on the Manual Tuning dialog box are available while online.



In the RSLogix 5000® software, version 20 and later you can make edits when online. In the RSLogix 5000 software, version 19 and earlier, changes can only be made when online and the SERVO is enabled.

When you adjust the sliders, you can see what gains were updated. When the servo is on, the left area of the dialog box lights up. This option gives you real manual tuning capability. When you expand the Tuning Configuration, you are reminded of the application type and coupling (loop response affects the system damping) you selected. These values are governing the displayed values.

There are three Loop Response settings on the General dialog box.

### Loop Responses

This dialog box is where you can enter values for system bandwidth and system damping, which affect the loop gains. You can also individually modify the gains with sliders, bandwidth parameters, or manual changes. The gains and filters that you have tuned by using either default factory values or Autotune are your initial values in the Manual Tune dialog box. Coupling displays how tightly set or how you chose the system to tune.

The Motion Console dialog box displays Manual Tuning and Motion Generator. Use the left of the dialog box to test in an inactive state. As you perform the tune, you can test in an active state with Motion Generator.

**General**

Axis Configuration: Position Loop

Feedback Configuration: Motor Feedback

Application Type: Basic

Loop Response: Medium

Assigned Group: Low

Motion Group: MG

Loop Response relates to the following values for System Damping.

Low = 1.5

Medium = 1.0

High = 0.8

**Motion Console - K6K\_Axis**

**Manual Tuning**

System Bandwidth: 0.0 Hertz

System Damping: 1.0

**Tuning Configuration**

Application Type: Basic

Coupling: Rigid

**Gains To Tune**

Position Integrator Bandwidth

Velocity Integrator Bandwidth

System Damping is for setting the axis Bandwidth and Error Tolerance values.

**Motion Console - K5300\_Axis**

**Manual Tuning**

System Bandwidth: 0.0 Hertz

System Damping: 1.0

**Tuning Configuration**

**Position Loop**

Loop Bandwidth: 19.6418 Hertz

Integrator Bandwidth: 0.0 Hertz

Integrator Hold: Disabled

Error Tolerance: 0.81028694 Position Units

**Velocity Loop**

Loop Bandwidth: 78.5672 Hertz

Integrator Bandwidth: 0.0 Hertz

Integrator Hold: Disabled

Error Tolerance: 111.114555 Position Units/s

**Motion Generator**

Commands

Label	Operand
Move Type	Absolute
Position	0
Speed	0
Speed Units	Units per sec
Accel Rate	100
Accel Units	Units per sec <sup>2</sup>
Decel Rate	100
Decel Units	Units per sec <sup>2</sup>
Profile	Trapezoidal

Axis State:

Axis Fault:

Start Inhibited:

Execute Disable Axis

**Additional Tune**

Velocity Feedforward: 100.0 %

Acceleration Feedforward: 0.0 %



**ATTENTION:** Before you tune or test axis motion, make sure no one is in the way of the axis.

Typically motion does not occur in Program mode but you can test an axis in Remote Program mode by using Motion Direct Commands.

When you tune an axis, your code is **not** in control of the axis.

## Tune The Axis

The tuning procedure tunes the proportional gains. Typically, tune the proportional gains first and see how your equipment runs.

Follow these instructions to tune an axis manually.

- To open Manual Tune, do one of the following:
  - Double-click an axis while online with a controller.
  - Right-click an axis and choose Manual Tune.
  - Click Manual Tune in the lower left of any category dialog box.

The Manual Tune dialog box appears.

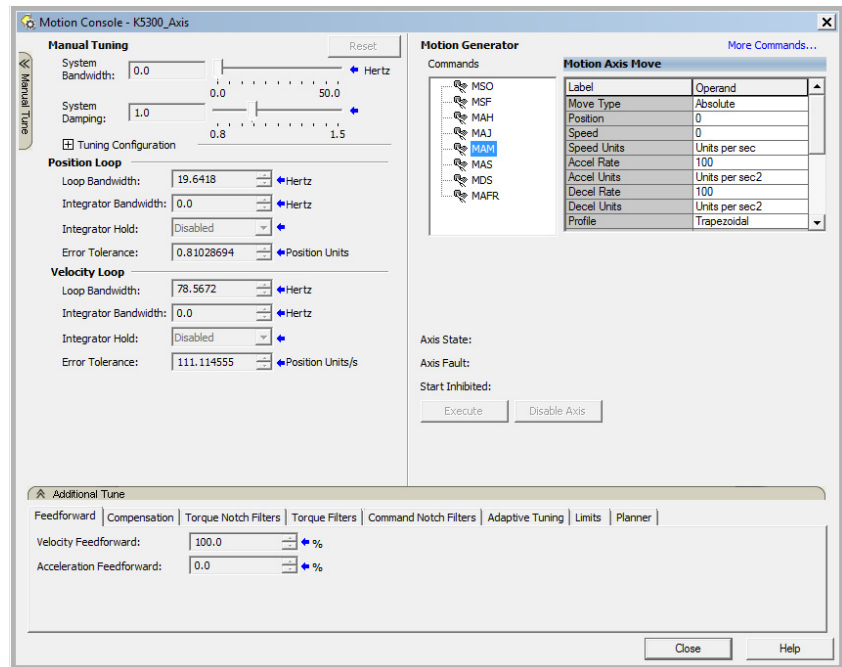

When the Manual Tune dialog box appears, you can find that you cannot see the entire console. You can create more space for the console by reducing the size of the Controller Organizer or by adjusting the toolbars.

- Adjust your settings according to your application.
- When you change a value, it is sent to the controller immediately.
- Execute a command.
- Watch the result.
- Make the necessary adjustments and execute a command.



You can click Reset to return to default values.

For more information on how to manually tune, see the Motion System Tuning Application Technique, publication [MOTION-AT005](#).

# Motion Generator and Motion Direct Commands

The commands on the Motion Generator give you basic control of a closed-loop servo axis.

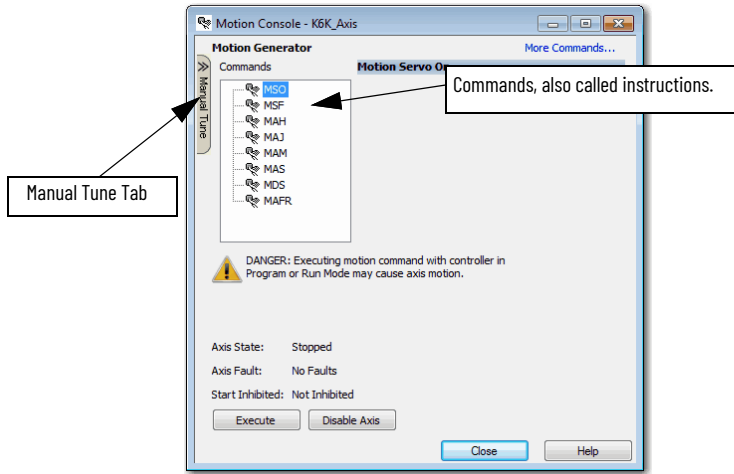

The following instructions are available on the Motion Generator dialog box.

**Table 49 - Available Instructions**

Command	Description
MDS	Motion Drive Start
MSO	Motion Servo On
MSF	Motion Servo Off
MAH	Motion Axis Home
MAJ	Motion Axis Jog
MAM	Motion Axis Move
MAS	Motion Axis Stop
MAFR	Motion Axis Fault Reset

When you click the More Commands link on the Motion Generator, you are taken to the Motion Direct Commands dialog box. In this dialog box, you can observe the effects of the manual tune. You can turn the axis on and off, home and move the axis, and reset faults.

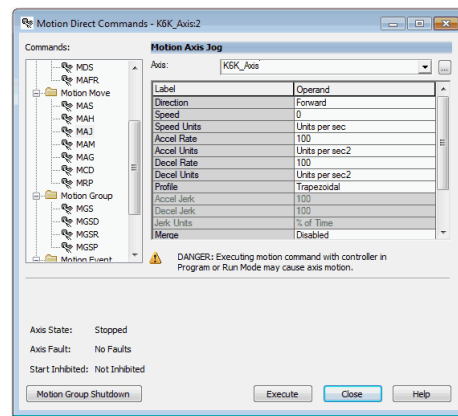

Follow these instructions to use a Motion Direct Command.

1. Select MSO (Motion Servo On) and click Execute.

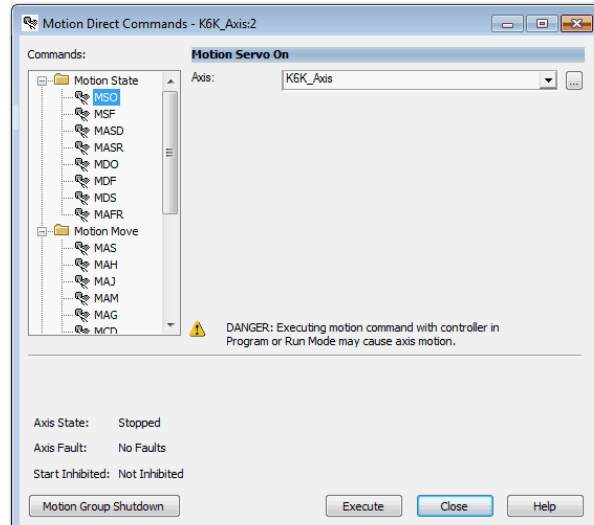

2. Click Reset.  
Reset restores all values that were there when you first opened Manual Tune.
3. Select MAM (Motion Axis Move) and click Execute.

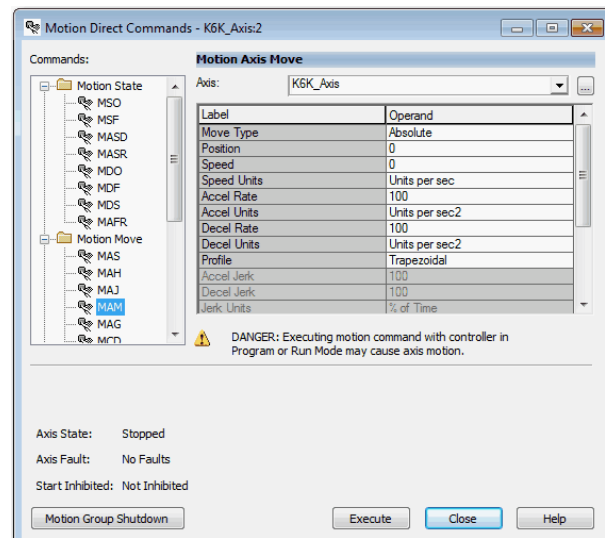

4. Click Execute.  
Your drive moves according to your configuration settings.
5. Adjust your settings, if desired.
6. Select another command and click Execute.

## Additional Tune

The Additional Tune section gives you access to additional tuning parameters, typically needed for more advanced servo loop settings. Additional Tune provides access of up to eight parameter tabs depending on the drive and firmware that are used for the application:

- Feedforward
- Compensation
- Torque Notch Filters
- Torque Filters
- Command Notch Filters
- Adaptive Tuning
- Limits
- Planner



You may have to turn all your toolbars off to see the complete screen. When you are done, choose View>Toolbars>Factory Defaults, or turn on the toolbars you want to see.

The type of drive you are using determines the attributes that appear on the tabs. All possible attributes are not shown in the following sections.

See the Integrated Motion on the EtherNet/IP™ network Reference Manual, publication [MOTION-RM003](#), for detailed information about the AXIS\_CIP\_DRIVE attributes.

## Feedforward Parameters

The Feedforward tab lets you adjust velocity and acceleration feedforward.

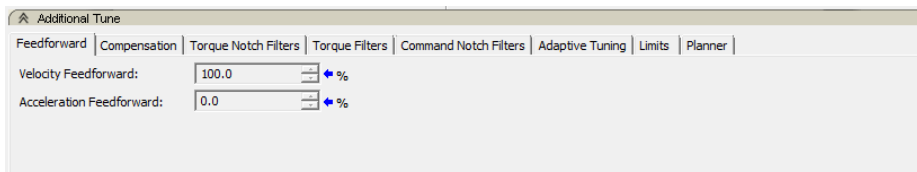

Attribute <sup>(1)</sup>	Description
Velocity Feedforward	A command signal that is a scaled version of the command velocity profile.
Acceleration	A signal that is a scaled version of the command acceleration profile.
AC Line Current Power Feedforward Gain	A value that is a scaled version that inverter Output Power signal that is applied to the line-side current control loop of the regenerative converter.

(1) The attributes that you can edit depend on your drive and firmware revision.

## Compensation Parameters

The Compensation tab lets you input scaling gain and friction offset values.

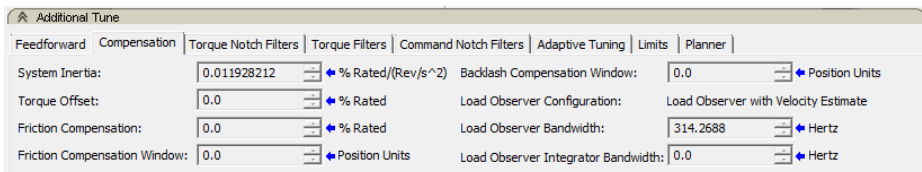

Attribute <sup>(1)</sup>	Description
System Inertia	Torque or force scaling gain value that converts commanded acceleration into equivalent rated torque/force.
Torque Offset	Provides a torque bias when performing closed-loop control.
Friction Compensation	Value that is added to the current/torque command to offset the effects of friction.
Friction Compensation Window	Defines a window around the command position.
Backlash Compensation Window	Defines a window around the command position.
Load Observer Configuration	Configures the operation of the Load Observer.
Load Observer Bandwidth	Determines the proportional gain, $Kop$ , of the load observer.
Load Observer Integral Bandwidth	Determines the load observer integral gain, $Koi$ , that together with the $Kop$ , multiplies the integrated error signal within the observer.

(1) The attributes that you can edit depend on your drive and firmware revision.

## Torque Notch Filters Parameters

The Torque Notch Filters tab lets you adjust configuration values for the torque notch filters.

Attribute <sup>(1)</sup>	Description
Torque Notch Filter N Frequency	Center frequency of each torque notch filter that is applied to the torque reference signal.
Torque Notch Filter N Width	Width of each notch filter that is applied to the torque reference signal. When multiple resonance frequencies are close in frequency, a wider notch filter can potentially suppress them both.

(1) The attributes that you can edit depend on your drive and firmware revision.

## Torque Filters Parameters

The Torque Filters tab lets you input torque low pass and lag filter values.

Attribute <sup>(1)</sup>	Description
Torque Low Pass Filter Bandwidth	Break frequency for the second order low pass filter that is applied to the torque reference signal.
Torque Lag Filter Gain	Sets the high frequency gain of the torque reference Lead-Lag Filter.
Torque Lag Filter Bandwidth	Sets the lag filter that is applied to the torque reference filter.

(1) The attributes that you can edit depend on your drive and firmware revision.

## Command Notch Filters Parameters

The Command Notch Filters tab lets you adjust configuration values for the torque notch filters.

Attribute <sup>(1)</sup>	Description
Command Notch Filter N Frequency	Center frequency of each command notch filter that is applied to the command signal.
Command Notch Filter N Width	Width of each command notch filter that is applied to the command signal.

(1) The attributes that you can edit depend on your drive and firmware revision.

## Adaptive Tuning Parameters

The Adaptive Tuning tab lets you adjust Adaptive Thing configuration values.

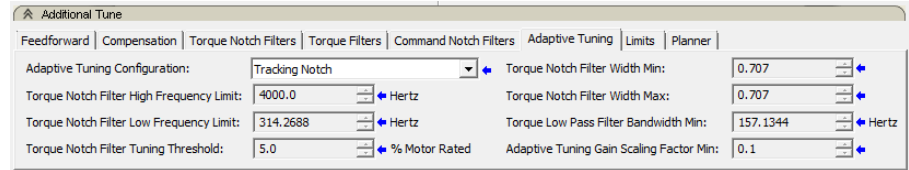

Attribute <sup>(1)</sup>	Description
Adaptive Tuning Configuration	Controls the Adaptive Tuning feature mode of operation.
Torque Notch Filter High Frequency Limit	Adaptive Tuning identifies resonances that are not associated with the command between these low and high frequency limits with magnitudes above this tuning threshold.
Torque Notch Filter Low Frequency Limit	
Torque Notch Filter Tuning Threshold	
Torque Notch Filter Width Min	The adaptive tuning Tracking Notch function adjusts torque notch filter widths proportional to the frequency estimate in relation to the high and low frequency limits. It sets torque notch filter widths equal to this minimum width when the frequency estimate is equal to the low frequency limit. It sets torque notch filter widths equal to this maximum width when the frequency estimate is equal to the high frequency limit. The default setting is 0.707 for minimum and maximum width.
Torque Notch Filter Width Max	
Torque Low Pass Filter Bandwidth Min	In modes with Gain Stabilization, Adaptive Tuning incrementally decreases this bandwidth estimate from its default value in 200 Hz increments until it suppress resonances that notch filters do not already suppress above the low frequency limit, if necessary. The Torque Low Pass filter will not be decreased below the minimum bandwidth value.
Adaptive Tuning Gain Scaling Factor Min	In modes with Gain Stabilization, Adaptive Tuning incrementally decreases this gain scaling factor from its default value to stabilize the system if necessary. The gain scaling factor will not be decreased to a value below the minimum.

(1) The attributes that you can edit depend on your drive and firmware revision.

## Limits Parameters

The Limits tab lets you input peak, velocity, and acceleration or deceleration values.

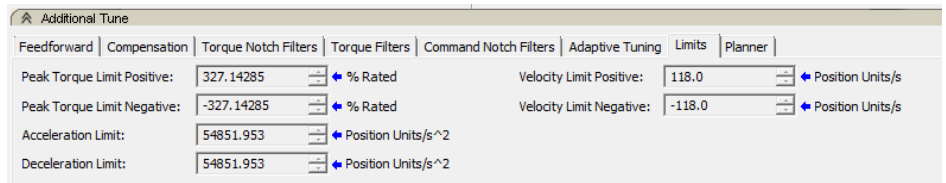

Attribute <sup>(1)</sup>	Description
Peak Torque Limit	Floating point that is based on calculations using Max Motor Torque, Max Drive Torque, Motor Peak Current, Motor Rated Current, and Drive Peak Current attributes.
Velocity Limit	Positive or Negative velocity reference value.
Acceleration	Defines the maximum acceleration (increase in speed) allowed for the acceleration reference value into the acceleration summing junction. The Kinetix® 350 does not support this attribute.
Deceleration	Defines the maximum deceleration (decrease in speed) allowed for the acceleration reference signal into the acceleration summing junction.

(1) The attributes that you can edit depend on your drive and firmware revision

## Planner Parameters

The Planner tab lets you input the maximum values for acceleration and deceleration.

Attribute <sup>(1)</sup>	Description
Maximum	The value of the Maximum Speed attribute that is used by various motion instructions to determine the steady-state speed of the axis.
Maximum Acceleration and Maximum Deceleration	The Maximum Acceleration and Maximum Deceleration values frequently used by motion instructions, for example, MAJ, MAM, and MCD, to determine the acceleration/deceleration rate to apply to the axis.
Maximum Acceleration and Maximum Deceleration Jerk	The Maximum Acceleration and Maximum Deceleration jerk values frequently used by motion instructions, for example, MAJ, MAM, and MCD, to determine the acceleration/deceleration rate to apply to the axis.

(1) The attributes that you can edit depend on your drive configuration.

## Configure Torque Values

More advanced servo loop settings typically require additional tuning parameters such as torque values. The type of drive you are using determines the values that appear.

Follow these steps to configure torque values:

1. Right-click an axis and click Manual Tune.
2. In the bottom-left corner of the Manual Console dialog box, click Additional Tune to display the additional tune tabs.
3. To access the torque values, click the Filters tab.
4. Adjust the torque values as desired.
5. After you adjust the values, click Additional Tune to close the tabs.

## Monitor Tags with the Quick Watch Window

The Quick Watch window lets you monitor the tags in your program while you are executing commands. To open Quick Watch, press ALT+3 or choose it from the View menu.

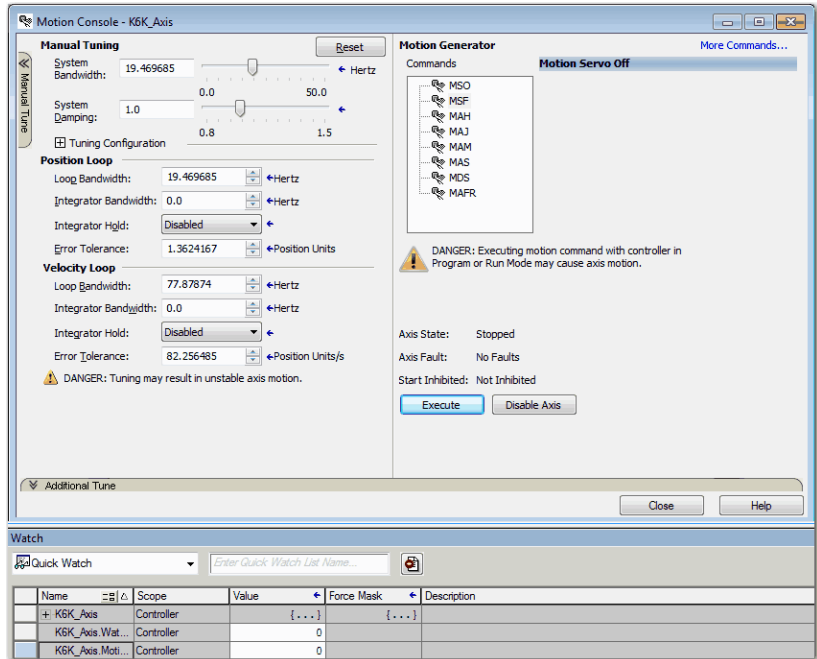

You create Quick Watch Lists by choosing Quick Watch from the dropdown menu.

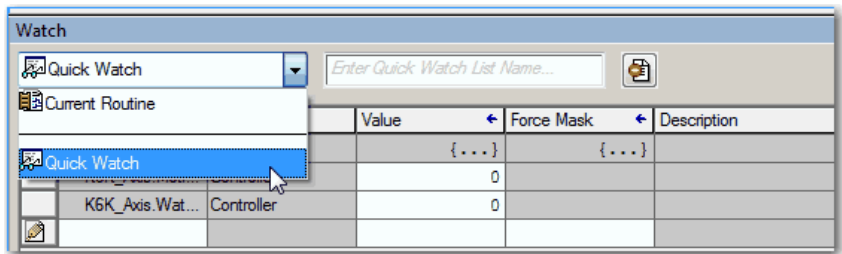

Once you name a Quick Watch List, it is available in the ACD, L5K, and L5X files. Make sure to name your lists. Lists that do not have names are lost when you close the software.

## Use Motion Generator

This example assumes the following:

- The servo is off, with session Online
  - Axis State: Stopped
  - Axis Faults: No Faults
1. Choose MSO (Motion Servo On).

This selection readies the drive for motion, and enables the servo loop.

2. Click Execute.

The axis state goes to Servo = On.

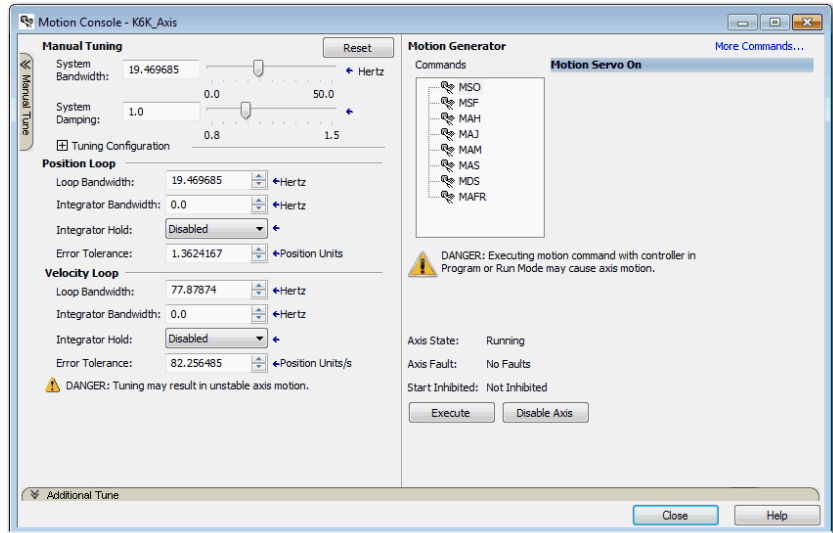

The Motion Console dialog box displays the following:

- Axis State: Running
- Axis Faults: No Faults

The Results window displays the following message.

```
Errors
Going online with controller...
Complete - 0 error(s), 0 warning(s)
Motion Console - Axis_101, MSO, (16#0000) No Error
```

3. Select MAH (Motion Axis Home) and click Execute.

Use this step to execute the Homing command to establish a feedback positional reference, if a Position loop is being tuned.

The axis state goes Servo-On, and the controller performs the Axis Home procedure, which is based on the configured Home settings.

The Motion Console dialog box appears:

- Axis State: Running
- Axis Faults: No Faults

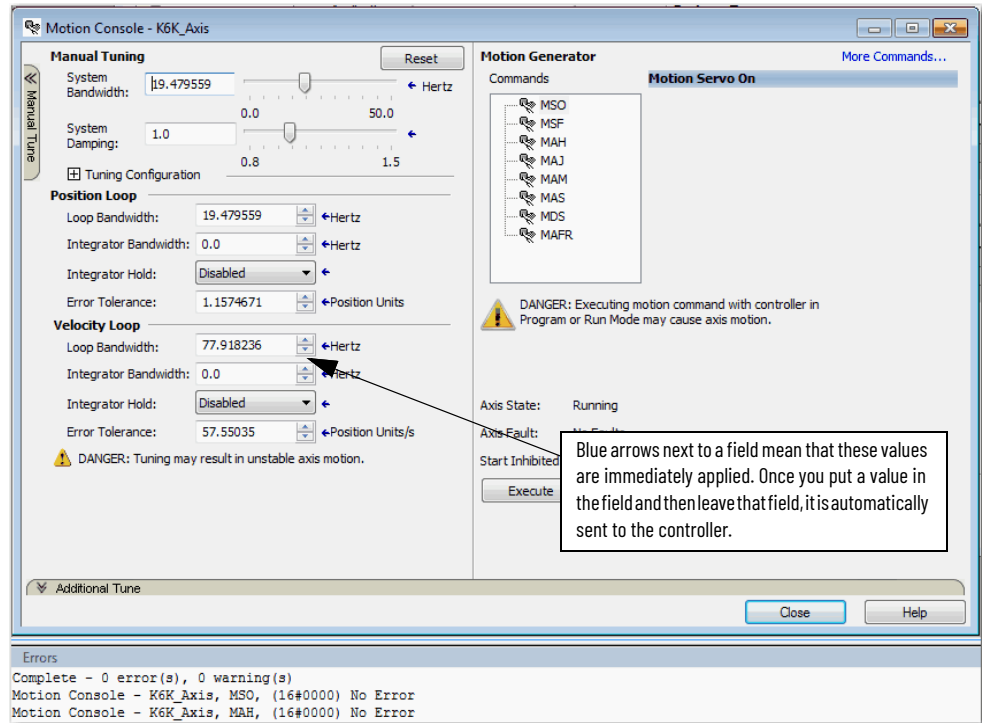

The Results window displays No Error.

4. Choose MAM (Motion Axis Move).

This step initiates an Axis-Move at the selected speed, acceleration/deceleration, profile, and endpoint position and lets you observe the axis response.

Before executing this MAM Move, you can initiate a method to observe the axis response during the move.

Some examples include the following:

- Watch-window:  
Quick Watch tag name = Axis\_y.ActualPosition or = Axis\_y.ActualVelocity
- New Trend with Tags:  
Axis\_y.ActualPosition or = Axis\_y.ActualVelocity
- Axis Properties:  
Status dialog box = Axis\_y.ActualPosition or = Axis\_y.ActualVelocity

## 5. Click Execute.

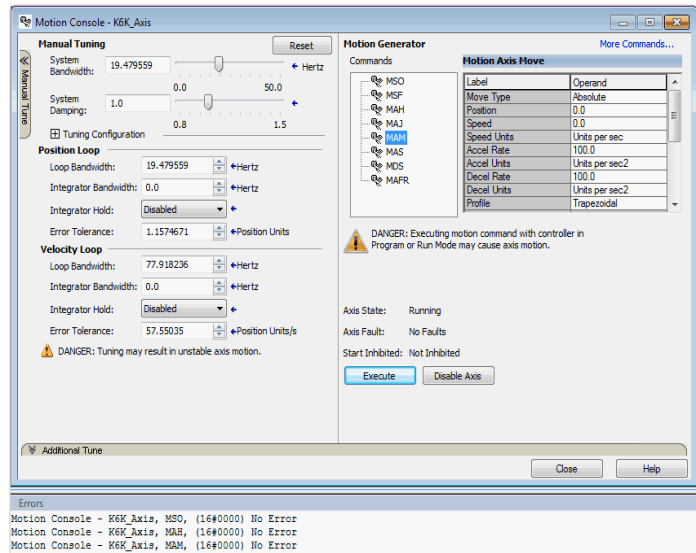

The controller performs a controlled axis move.

The Motion Console dialog box appears:

- Axis State: Running
- Axis Faults: No Faults

The Results window displays No Error.

## 6. Observe and verify the Axis response.

The axis motion moves according to the configured MAM settings:

- If the settings and response are satisfactory, then tuning is finished and you can close Manual Tune.
- If the settings or responses are not satisfactory, stay in Manual Tune and adjust the parameters.

**Notes:**

## Status, Faults, and Alarms

There are four ways to find and view faults and alarms:

- Fault and Alarm Log
- QuickView® Pane
- Tag Monitor, see the individual fault-related attributes
- Drive Status Indicators

### Faults and Alarms Dialog Box

The Faults and Alarms dialog box displays the status of faults and alarms in the controller for an axis. The display is read-only except for the ability to clear logs. Fault and alarm entries are displayed only when you are online with a controller.

When online, check or clear the checkboxes in the Show row to show or hide the specified group of entries. Only the last 25 faults and alarms display.



Figure 99 - Faults and Alarms Log

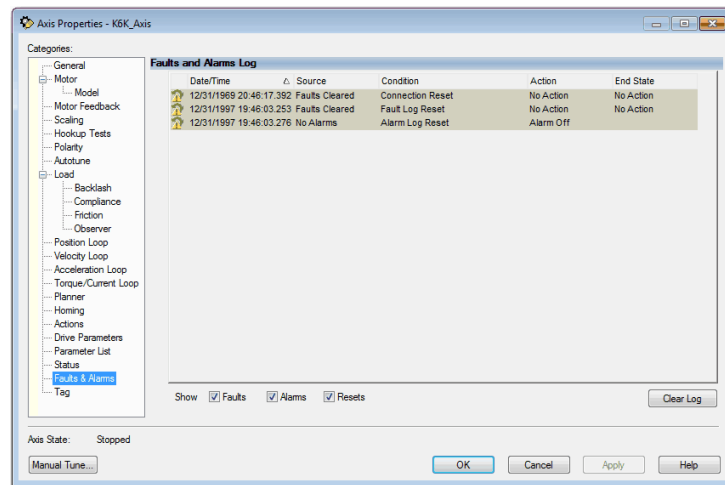

[Table 50](#) describes the parameters for the Faults and Alarms dialog box.

Table 50 - Faults and Alarms Dialog Box Descriptions

Parameter	Description
Indicator	Displays the following icons to indicate the state of a fault or alarm: <ul style="list-style-type: none"> <li>• Alarm On</li> <li>• Alarm Off</li> <li>• Fault Occurred</li> <li>• Reset Occurred</li> </ul>
Date/Time	Displays the date and time that the event occurred. The time stamp is the workstation setting.
Source	Displays the source of the event, for example: <ul style="list-style-type: none"> <li>• Safety Fault</li> <li>• Module Fault</li> <li>• Group Fault</li> <li>• Axis Fault</li> <li>• Axis Alarm</li> </ul>
Condition	Displays detailed information specific to the event category and code. For drive exception conditions, the information is the same text that is used for the condition. This field can contain more information when the Subcode field has been used for that entry. The field is a more detailed entry if both codes are used in the log, for example: <ul style="list-style-type: none"> <li>• Group Sync Failure</li> <li>• Bus Overvoltage UL</li> <li>• All Axis Faults</li> <li>• Motor Overspeed</li> <li>• Axis Init Fault</li> </ul>
Action	Displays the action command that was executed in response to the event as configured in the axis. For instance, in many cases this display indicates that a command sent to a drive, for example: <ul style="list-style-type: none"> <li>• Planned Stop</li> <li>• Ramped Stop</li> <li>• Limited Stop</li> <li>• Coast</li> <li>• No Action</li> <li>• Alarm Off</li> <li>• Alarm On</li> </ul>
End State	Displays the action result that is returned from the axis, which can be more detailed than the command sent. For instance, a send of disable can result in either Holding, Shutdown or other status, for example: <ul style="list-style-type: none"> <li>• Stopped - Hold</li> <li>• Stopped - Disable</li> <li>• Shutdown</li> <li>• Shutdown Reset</li> </ul>
Faults	Toggles between faults; display or hide.
Alarms	Toggles between alarms; display or hide.
Clear Log	Clears both the fault and alarm logs in the controller for this axis.

## QuickView Pane

The QuickView pane gives you a quick summary of faults and alarms that are related to the axis you select in the Controller Organizer. The information includes the type of axis, description, axis state, faults, and alarms.

2094-EN02D-M01-S1 K6K_Drive	
Axis 1 - 192.168.1.31	
Type	AXIS_CIP_DRIVE
Description	
Axis State	Stopped
Update Period	2.0 ms
Axis Fault	No Faults
Module Faults	No Faults
Group Fault	No Faults
Motion Fault	No Faults
Initialization Fault	No Faults
Attribute Error	No Faults
Guard Fault	No Faults
Guard Lock Status	Unlocked
Start Inhibited	Not Inhibited
Motor Catalog	MPL-A310P-M

## Data Monitor

The Data Monitor is where you can read and write the values that are assigned to specific tags, both online and offline.

You can do the following:

- Type a tag description.
- Change the display style of a value.
- Change a force mask value.
- Sort your tags alphabetically.

Name	Value	Force Mask	Style	Data Type
K6K_Axis	{...}	{...}		AXIS_CIP_DRIVE
K6K_Axis.AxisFault	16#0000_0000		Hex	DINT
K6K_Axis.AxisFault.0	0		Decimal	BOOL
K6K_Axis.AxisFault.1	0		Decimal	BOOL
K6K_Axis.AxisFault.2	0		Decimal	BOOL
K6K_Axis.AxisFault.3	0		Decimal	BOOL
K6K_Axis.AxisFault.4	0		Decimal	BOOL
K6K_Axis.AxisFault.5	0		Decimal	BOOL
K6K_Axis.AxisFault.6	0		Decimal	BOOL
K6K_Axis.AxisFault.7	0		Decimal	BOOL
K6K_Axis.AxisFault.8	0		Decimal	BOOL

## Motion Status

Use the Status category to:

- Display the status of the axis
- View the current state of the axis and CIP Safety™ drive
- Manually adjust axis drive attributes

The status tab displays the following:

- Position Data (Actual and Command)
- Velocity Data (Actual and Command)
- Axis status indicators
  - The indicators light up if the state has been reached. For example, if the Torque Limit is reached, the light next to that limit turns blue.
- Digital I/O status indicators
  - The indicators light up if the state has been reached. For example, if Registration 1 is reached, the light next to Registration 1 turns blue.

You can view the status of the digital I/O indicators in the Status category of the Axis Properties window. An example of the Status category is shown in the following figure.

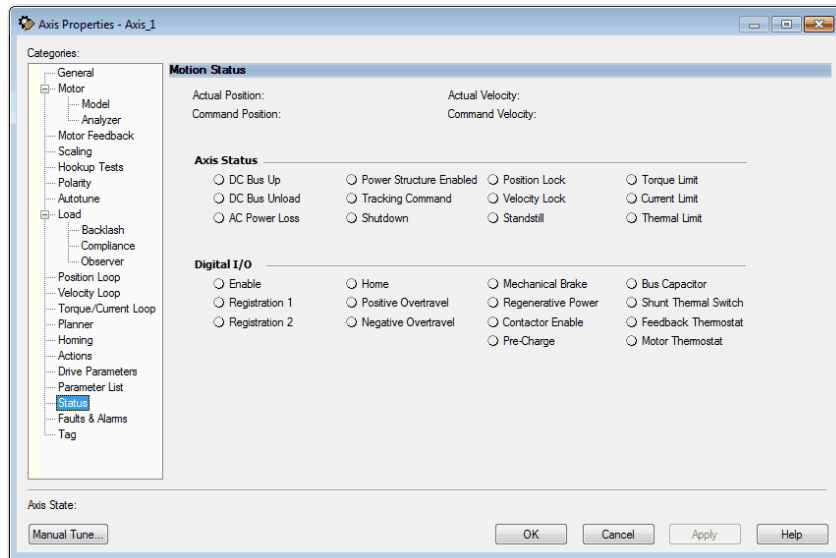

The following two tables detail the meaning of the status indicators per the axis tags.

**Table 51 - Axis Tags Status Indicators**

Bit	Required/Optional	Name	Digital I/O	Axis Status	Description
0	R	Enable Input	Off	0	Enable is not active
			On	1	Enable is active
1	R/E	Home Input	Off	0	Home is not active
			On	1	Home is active
2	R/E	Registration 1 Input	Off	0	Reg 1 is not active
			On	1	Reg 1 is active
3	O/E	Registration 2 Input	Off	0	Reg 2 is not active
			On	1	Reg 2 is active
4	R/P	Positive Overtravel OK Input	Off	0	Overtravel Fault
			On	1	No Overtravel Fault
5	R/P	Negative Overtravel OK Input	Off	0	Overtravel Fault
			On	1	No Overtravel Fault
6	O/E	Feedback 1 OK Thermostat	Off	0	Feedback 1 Thermostat Fault
			On	1	No Feedback 1 Thermostat Fault
7	O/D	Resistive Brake Release Output	Off	0	Motor connected to Brake Resistor
			On	1	Motor connected to Inverter
8	O/D	Mechanical Brake Release Output	Off	0	Brake is Engaged
			On	1	Brake is Released
9	O/D	Motor Thermostat OK Input	Off	0	Thermostat Fault
			On	1	No Thermostat Fault
10...31	-	Reserved	-	-	-

## Drive Status Indicators

For complete information on drive status indicators, refer to the publications listed in [Additional Resources on page 9](#).

## Connection Faults and Errors

The Connection tab provides you with information about the connection condition between the controller and a module. The information comes from the controller.

You can configure the controller so that a loss of connection causes a major fault. Fault codes are as follows:

Major Fault	Configure the controller so that a loss of connection to this module causes a major fault.
Module Faults	Displays the fault code that is returned from the controller and provides details about the fault.

[Table 52](#) describes common connection errors.

**Table 52 - Common Connection Errors**

Error	Description
Connection Request Error	The controller is attempting to make a connection to the module and has received an error. The connection was not made.
Service Request Error	The controller is attempting to request a service from the module and has received an error. The service was not performed successfully.
Module Configuration Invalid	The configuration in the module is invalid. Module Configuration Rejected - invalid power structure.
Electronic Keying Mismatch	Electronic Keying is enabled and some part of the keying information differs between the software and the module.

## Motion Faults

The controller has these types of motion faults.

**Table 53 - Motion Faults**

Type	Description	Example
Instruction error	Caused by a motion instruction: <ul style="list-style-type: none"> <li>Instruction errors do not affect controller operation.</li> <li>Review the error code in the motion control tag to see why an instruction has an error.</li> <li>Fix instruction errors to optimize execution time and make sure that your code is accurate.</li> </ul> See Error Codes (ERR) for Motion Instructions, publication <a href="#">MOTION-RM002</a> .	A Motion Axis Move (MAM) instruction with a parameter out of range.
Fault	Caused by an anomaly with the servo loop: <ul style="list-style-type: none"> <li>You choose whether motion faults cause major faults.</li> <li>Can shut down the controller if you do not correct the fault condition.</li> </ul>	<ul style="list-style-type: none"> <li>Loss of feedback.</li> <li>Actual position that exceeds an overtravel limit.</li> </ul>

## Manage Motion Faults

By default, the controller runs when there is a motion fault. As an option, you can configure motion faults to cause a major fault and shut down the controller.

To configure a fault type, follow these steps:

1. Right-click Motion Group and choose Properties.

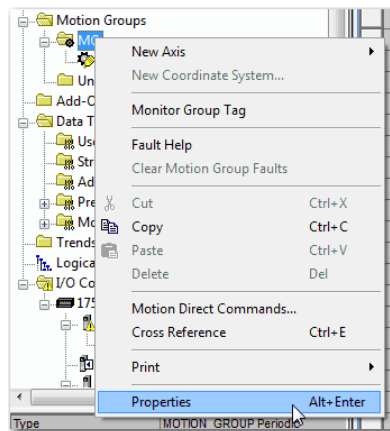

2. Click the Attribute tab.
3. From the General Fault Type dropdown menu, choose the general fault type.

If you want any motion fault to cause a major fault and shut down the controller, choose Major Fault. If you choose Non-Major Fault, you must write application code that enables the controller to handle the motion fault.

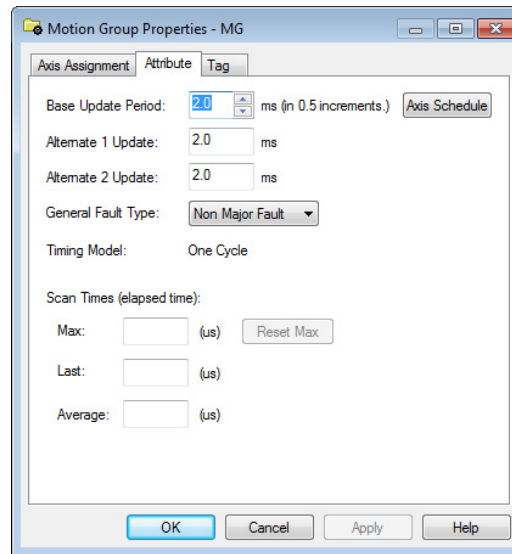

## Configure the Exception Actions for AXIS\_CIP\_DRIVE

Use exception actions to configure how an axis responds to different exception events. Exceptions that are applicable for an axis depend on the how the axis is configured.



**ATTENTION:** Modifying the Exception Action settings may require programmatically stopping or disabling the axis to protect personnel, machine, and property.



- The method that is used for stopping an axis for a Stop Drive exception action depends on the specific exception condition as determined by the drive. The action does NOT depend on the configured Disable (MSF) Stopping Action parameter on the Actions page.
- When a previously selected entry is no longer supported due to a configuration change, most of the conditions default to Disable. In the few cases where Disable does not apply, the default is Fault Status Only. For example, Disable does not apply with a feedback-only type configuration.

The drive the axis is associated with controls the available actions for each Exception. When a fault or alarm occurs, the corresponding fault or alarm axis attributes are set.

See Exception, Fault, and Alarm Attributes in the Integrated Motion on the EtherNet/IP™ Network Reference Manual, publication [MOTION-RM003](#).

To configure the Exception Actions, open the Axis Properties Exceptions dialog box.

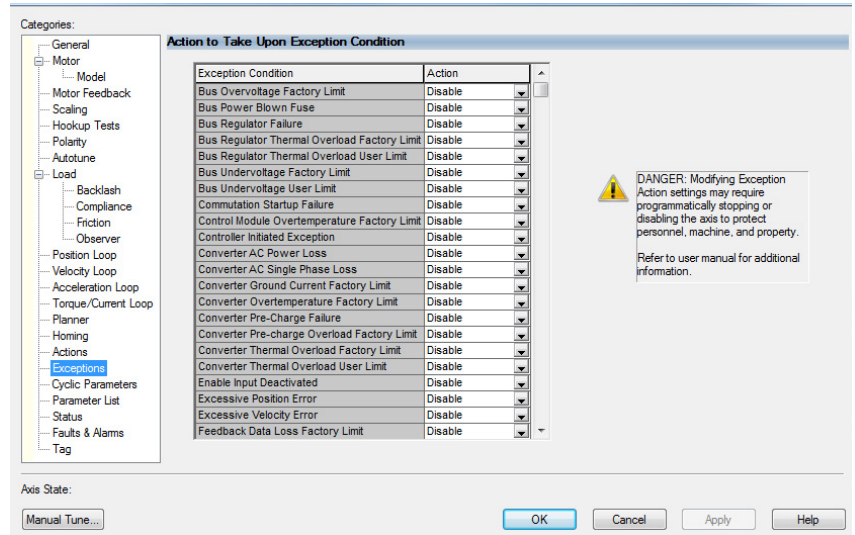

Options for each of the actions and the list of Exceptions can change based on how you configure the drive. If an exception is not possible for a specific drive (as defined by the profile of the drive), then that exception is not shown in this list.

The drive can restrict the list of actions that are taken. When a previously selected entry is no longer supported due to a configuration change, most of the entries default to Disable. In the few cases where Disable does not apply, the default is Fault Status Only. For example, Disable does not apply with a Feedback Only type configuration.

Figure 100 - Action Parameter Group Dialog Box

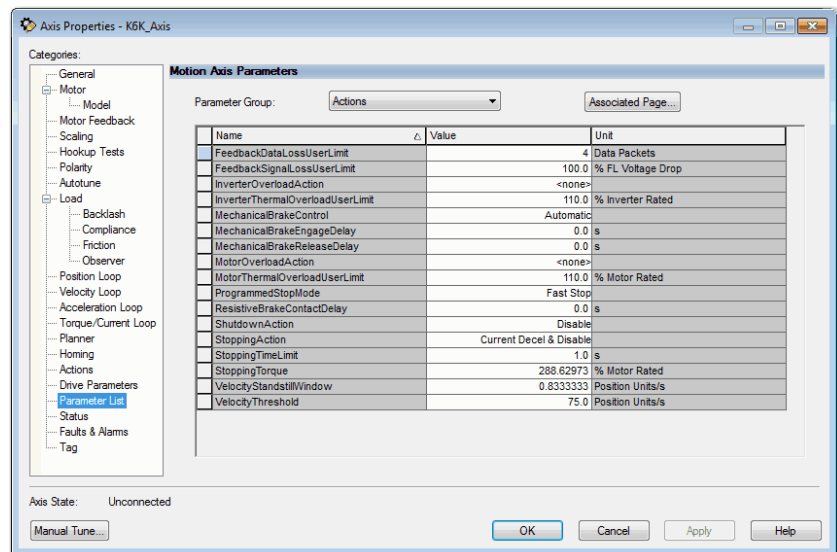

**Table 54 - Action Tasks and Related Faults**

Task	Choose	Description
Shut down the axis and let it coast to a stop.	Shutdown	<p>Shutdown is the most severe action. Use it for faults that could endanger the machine or the operator if you do not remove power quickly and completely.</p> <p>A fault happens when the following occurs:</p> <ul style="list-style-type: none"> <li>• Axis servo action is disabled</li> <li>• Servo amplifier output is zeroed</li> <li>• Appropriate drive enable output is deactivated</li> <li>• OK contact of the servo module opens. Use this contact to open the E-stop string to the drive power supply</li> </ul>
Stop the axis and let the drive stop the axis where you use the Stopping Action attribute to configure how to stop the drive.	Disable	<p>A fault happens when the following occurs:</p> <ul style="list-style-type: none"> <li>• Axis servo action is disabled</li> <li>• Servo amplifier output is zeroed</li> <li>• Appropriate drive enable output is deactivated</li> <li>• Drive switches to local servo loop control and the axis is slowed to a stop by using the Stopping Torque</li> <li>• The servo action and the power structure are disabled if the axis doesn't stop in the stopping time</li> </ul>
Leave the servo loop on and stop the axis at its Maximum Deceleration rate.	Stop Planner	<p>Use this fault action for less severe faults. It is the gentlest way to stop. Once the axis stops, you must clear the fault before you can move the axis. The exception is Hardware Overtravel and Software Overtravel faults, where you can jog or move the axis off the limit.</p>
		<p>A fault happens when the following occurs:</p> <ul style="list-style-type: none"> <li>• Axis slows to a stop at the Maximum Deceleration Rate without disabling the servo action or the servo module Drive Enable output</li> <li>• Control of the servo loop of the drive is maintained</li> <li>• Axis slows to a stop at the Maximum Deceleration rate without disabling the drive</li> </ul>
Write your own application code to handle the fault.	Fault Status Only	<p>Use this fault action only when the standard fault actions are not appropriate. With this fault action, you must write code to handle the motion faults. For Stop Motion or Status Only, the drive must stay enabled for the controller to continue to control the axis. Select Status Only to let motion continue only if the drive itself is still enabled and tracking the command reference.</p>
	Ignore	<p>Ignore instructs the device to ignore the exception condition. For some exceptions that are fundamental to the operation of the axis, it is not possible to Ignore the condition.</p>
	Alarm	<p>Alarm action instructs the device to set the associated bit in the Axis Alarm word, but does not otherwise affect axis behavior. For some exceptions that are fundamental to the operation of the device, it is not possible to select this action or any other action that leaves device operation unaffected.</p>

# Inhibit an Axis

**IMPORTANT** You can inhibit an axis only if the axis has been previously synched to the group. If the axis has not been synched to the group, you cannot inhibit the axis.

Inhibit an axis when you want to block the controller from using an axis because the axis has faulted or is not installed. You can also inhibit an axis to let the controller use other axes.

You want to block the controller from using an axis because the axis has faulted or is not installed.

You want to let the controller use the other axes.

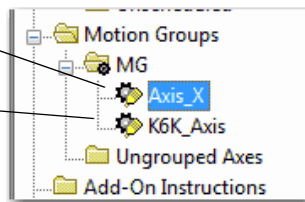

See [Example: Inhibit and Axis on page 192](#) and [Example: Uninhibit an Axis on page 193](#) for more information.

**Table 55 - Inhibit Axes**

<p><b>Before you inhibit or uninhibit an axis, turn off all axes.</b></p>	<p>Before you inhibit or uninhibit an axis, know that inhibit/uninhibit of an axis also affects any half axes in the same drive.</p> <ol style="list-style-type: none"> <li>1. Stop all motion in the axis.</li> <li>2. Use an instruction such as the Motion Servo Off (MSF) for the axis.</li> </ol> <p>This process lets you stop motion under your control. Otherwise the axes turn off on their own when you inhibit or uninhibit one of them.</p> <p>CIP™ only connections to the drive with the affected axis are shut down. Connections and motion on all other drives axes continue uninterrupted.</p> <p>The controller automatically restarts the connections.</p>
<p>To inhibit the axes, inhibit the communication module.</p>	<p>Do you want to inhibit the integrated motion on the EtherNet/IP network axes?</p> <ul style="list-style-type: none"> <li>• YES—Inhibit the 1756-ENxT communication modules.</li> <li>• NO—Inhibit the individual axes.</li> </ul> <p>You can inhibit the axes of a module on an individual basis. However, it is more efficient to inhibit all axes at once by inhibiting the module.</p>

### Example: Inhibit and Axis

**IMPORTANT** If you inhibit an axis on a drive, you inhibit all action on the drive, including any half axes. Verify that you are aware of all action on a drive before inhibiting the axis.

1. Verify that all axes are off.

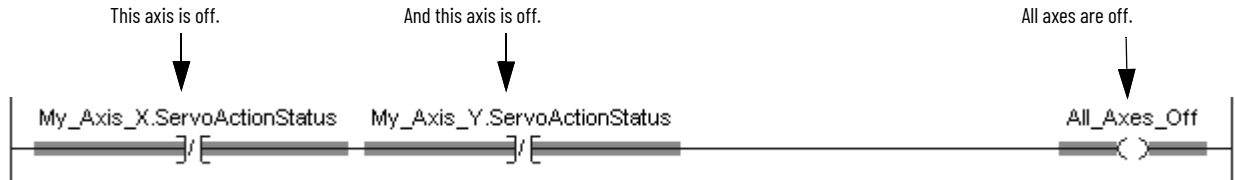

2. Trigger the inhibit with a one-shot instruction.

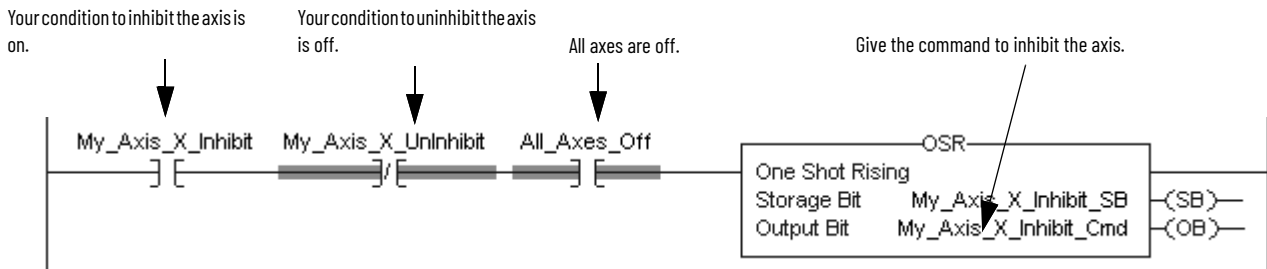

3. Inhibit the axis.

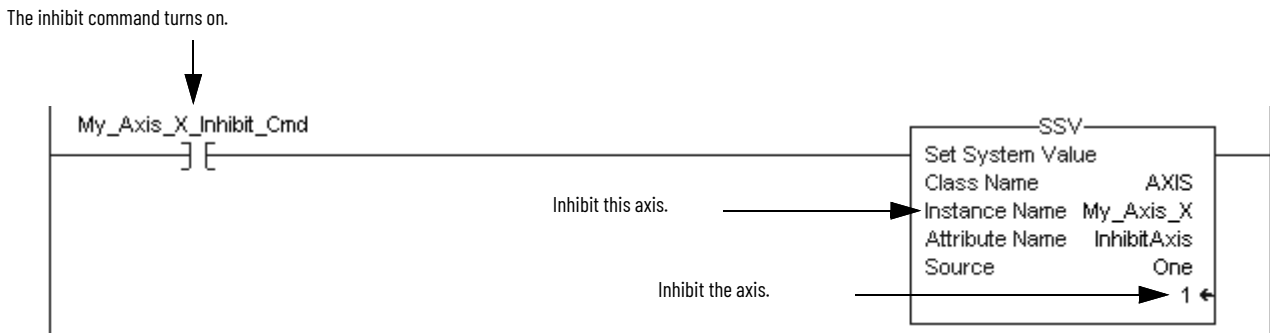

4. Wait for the inhibit process to finish.

- The following have happened:
- The axis is inhibited.
  - All uninhibited axes are ready.
  - The connections to the motion drive module are running again.

What you want to do next?



### Example: Uninhibit an Axis

**IMPORTANT** If you inhibit an axis on a drive, you inhibit all action on the drive, including any half axes. Verify that you are aware of all action on a drive before inhibiting the axis.

1. Verify that all axes are off.

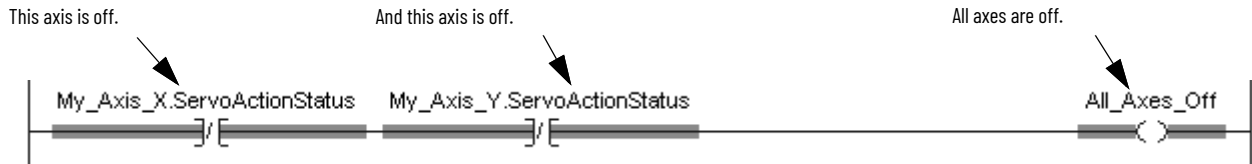

2. Trigger the uninhibit with a one-shot instruction

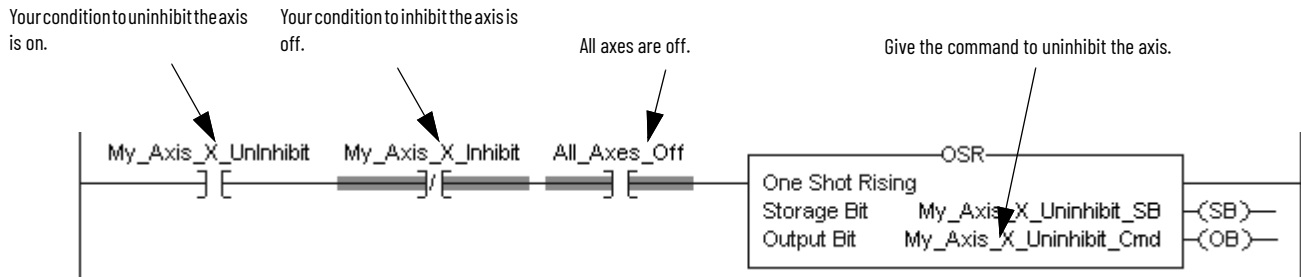

3. Uninhibit the axis.

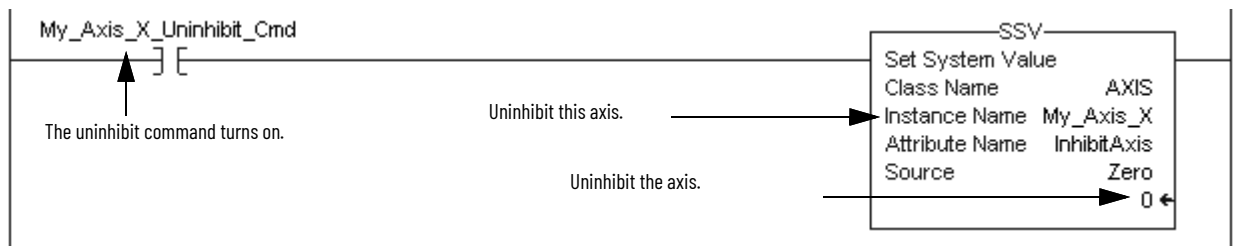

4. Wait for the inhibit process to finish

The following have happened:

- The axis is uninhibited.
- All uninhibited axes are ready.
- The connections to the motion drive module are running again.

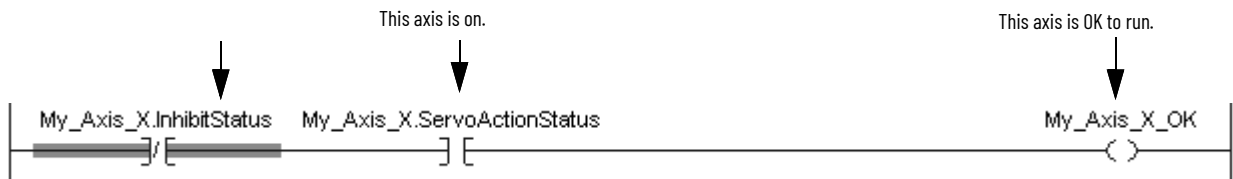

**Notes:**

## Parameter Group Dialog Boxes

### Parameter Group Dialog Boxes

This appendix describes the parameter group dialog-boxes. You can access all parameters that are associated with each category dialog box by clicking Parameters on the dialog box.

Each Parameter dialog-box list can contain more attributes than the associated category dialog box. In some cases, attributes that are contained on the Parameter List dialog box are not contained on the associated category dialog box.

**Figure 101 - Scaling Parameters**

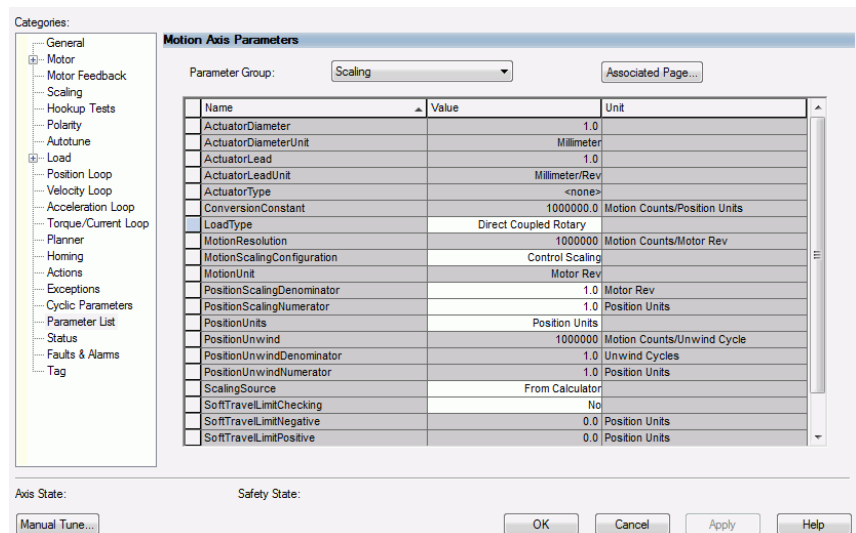

You can configure advanced parameters only on the dialog box for that group. Not all parameters can be set on each category dialog box.

This dialog box is an example of the parameters available for an axis that is configured as a Position Loop. There are six parameters that you can set on the Position Loop and Position Loop Parameter Group dialog boxes.

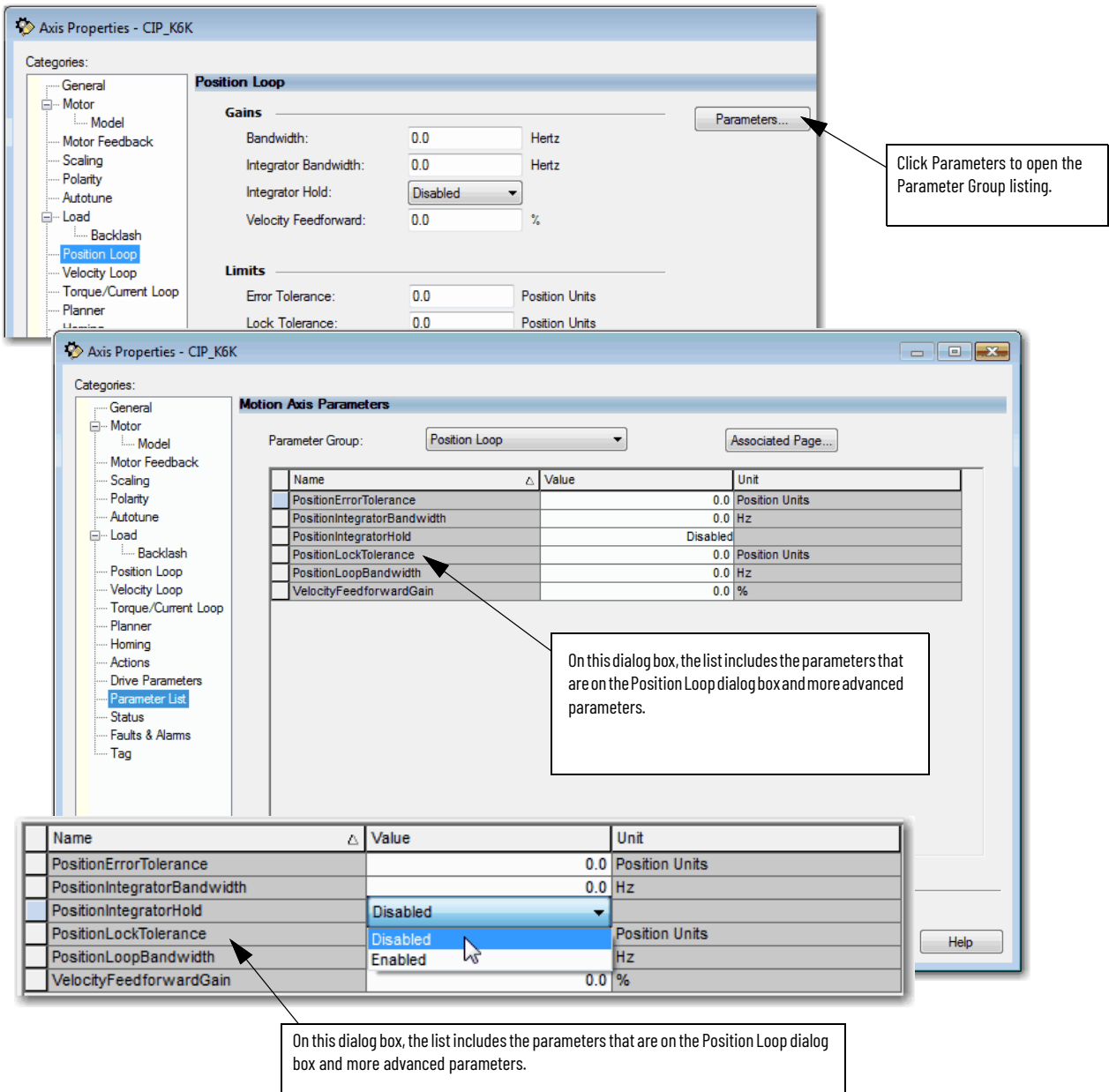
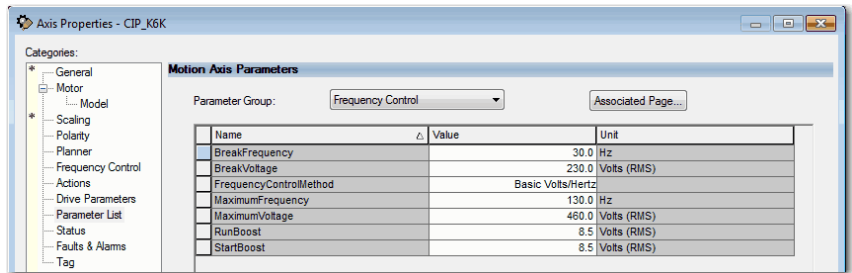

Figure 102 - Frequency Control Parameters



## Program a Velocity Profile and Jerk Rate

This appendix describes how to program a velocity profile and jerk rate.

### Program a Velocity Profile and Jerk Rate

You can use either of these motion profiles for various instructions:

- Trapezoidal profile for linear acceleration and deceleration
- S-curve profiles for controlled jerk

### Definition of Jerk

The Jerk is the rate of change of acceleration or deceleration.

The jerk parameters apply only to S-curve profile moves that use these instructions:

- MAJ
- MAM
- MAS
- MCD
- MCS
- MCCD
- MCCM
- MCLM

For example, if acceleration changes from 0 to 40 mm/s<sup>2</sup> in 0.2 seconds, the jerk is:

$$(40 \text{ mm/s}^2 - 0 \text{ mm/s}^2) / 0.2 \text{ s} = 200 \text{ mm/s}^3$$

### Choose a Profile

Consider cycle time and smoothness when you choose a profile.

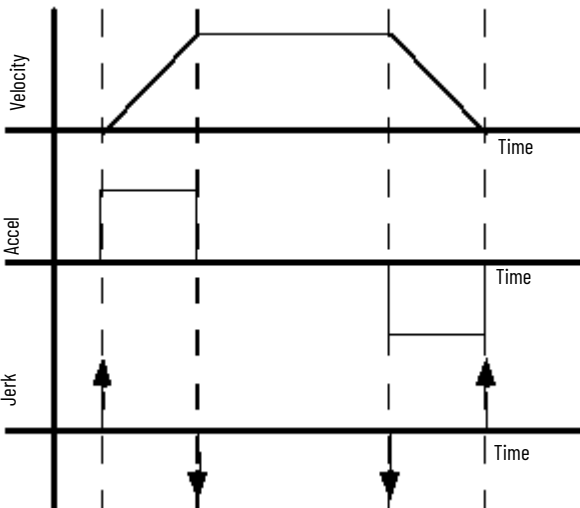
If You Want	Choose This Profile	Consideration
<ul style="list-style-type: none"> <li>• Fastest acceleration and deceleration times</li> <li>• More flexibility in programming subsequent motion</li> </ul>	<p>Trapezoidal</p> 	<p>Jerk <b>doesn't</b> limit the acceleration and deceleration time:</p> <ul style="list-style-type: none"> <li>• The Acceleration and Deceleration rates control the maximum change in Velocity.</li> <li>• Your equipment and load get more stress than with an S-curve profile.</li> <li>• Jerk is considered infinite and is shown as a vertical line.</li> </ul>

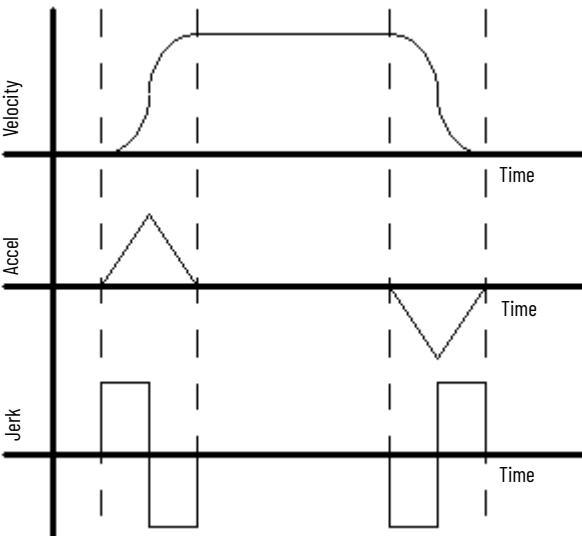
If You Want	Choose This Profile	Consideration
<p>Smoother acceleration and deceleration that reduces the stress on the equipment and load</p>	<p>S-curve</p> 	<p>Jerk limits the acceleration and deceleration time:</p> <ul style="list-style-type: none"> <li>• It takes longer to accelerate and decelerate than a trapezoidal profile.</li> <li>• If the instruction uses an S-curve profile, the controller calculates acceleration, deceleration, and jerk when you start the instruction.</li> <li>• The controller calculates triangular acceleration and deceleration profiles.</li> </ul>

### Use % of Time for the Easiest Programming of Jerk

Use % of Time to specify how much of the acceleration or deceleration time has jerk. You don't have to calculate actual jerk values.

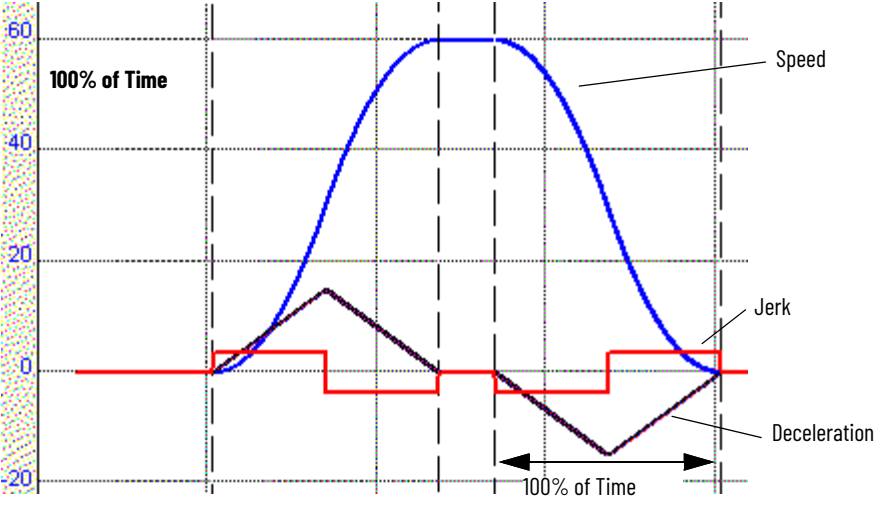
Example	Profile
<p>100% of Time</p>	<p>At 100% of Time, the acceleration or deceleration changes the entire time that the axis speeds up or slows down.</p> 

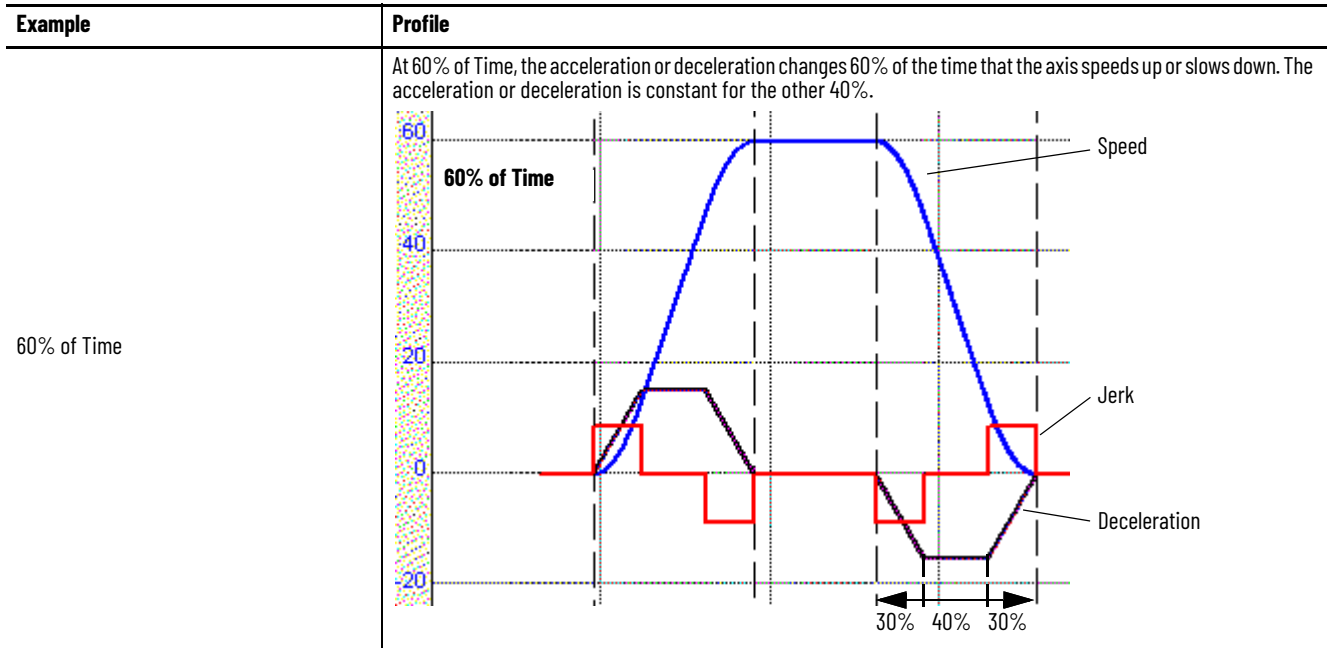

### Velocity Profile Effects

Table 56 summarizes the differences between profiles.

Table 56 - Profile Differences

Profile	ACC/DEC	Motor	Priority of Control			
Type	Time	Stress	Highest to Lowest			
Trapezoidal	Fastest	Worst	Acc/Dec	Velocity	Position	
S-curve	2X Slower	Best	Jerk	Acc/Dec	Velocity	Position

### Jerk Rate Calculation

If the instruction uses or changes an S-curve profile, the controller calculates acceleration, deceleration, and jerk when you start the instruction.

The system has a Jerk priority planner. In other words, Jerk always takes priority over acceleration and velocity. Therefore, you always get the programmed Jerk. If a move is velocity-limited, the move does not reach the programmed acceleration and/or velocity.

Jerk Parameters for MAJ programmed in units of % time are converted to engineering units as follows:

If Start Speed < MAJ Programmed Speed

$$\text{Accel Jerk (Units/Sec}^3\text{)} = \frac{\text{Programmed Accel Rate}^2}{\text{Programmed Speed}} * \left( \frac{200}{\% \text{ of Time}} - 1 \right)$$

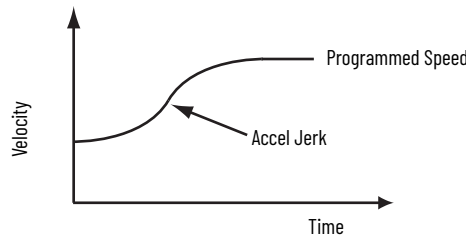

If Start Velocity > MAJ Programmed Speed

$$\text{Decel Jerk (Units/Sec}^3\text{)} = \frac{\text{Programmed Decel Rate}^2}{\text{Max (Programmed Speed, [Start Speed - Programmed Speed])}} * \left( \frac{200}{\% \text{ of Time}} - 1 \right)$$

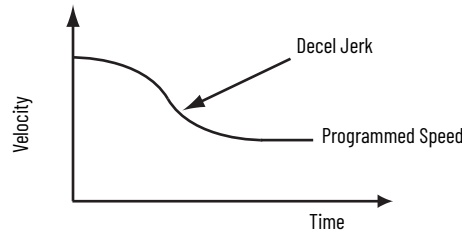

Jerks for programmed moves, such as MAM or MCLM instructions, in units of % time are converted to engineering units as follows:

If Start Speed < Programmed Speed

$$\text{Accel Jerk (Units/Sec}^3\text{)} = \frac{\text{Programmed Accel Rate}^2}{\text{Programmed Speed}} * \left( \frac{200}{\% \text{ of Time}} - 1 \right)$$

$$\text{Decel Jerk (Units/Sec}^3\text{)} = \frac{\text{Programmed Decel Rate}^2}{\text{Max (Programmed Speed, [Start Speed - Programmed Speed])}} * \left( \frac{200}{\% \text{ of Time}} - 1 \right)$$

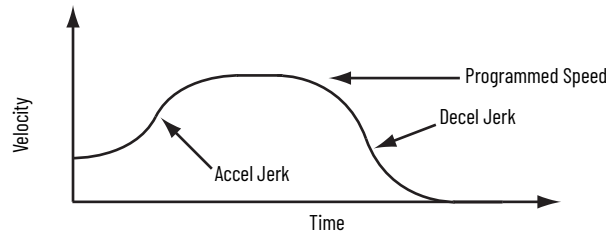

If Start Speed > Programmed Speed

$$\text{DecelJerk1} = \frac{\text{Programmed Decel Rate}^2}{\text{Max (Programmed Speed, [Start Speed - Programmed Speed])}} * \left( \frac{200}{\% \text{ of Time}} - 1 \right)$$

$$\text{DecelJerk2} = \frac{\text{Programmed Decel Rate}^2}{\text{Programmed Speed}} * \left( \frac{200}{\% \text{ of Time}} - 1 \right)$$

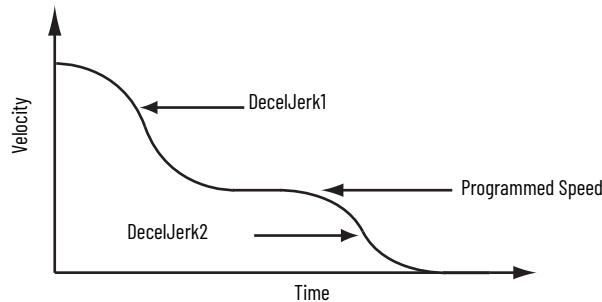

DecelJerk1 is used while Current Speed > Programmed Speed  
 DecelJerk2 is used while Current Speed < Programmed Speed

The same '% of time' jerk can result in different slopes for the acceleration profile than on the deceleration profile, dependent on the Speed parameter of the instruction.

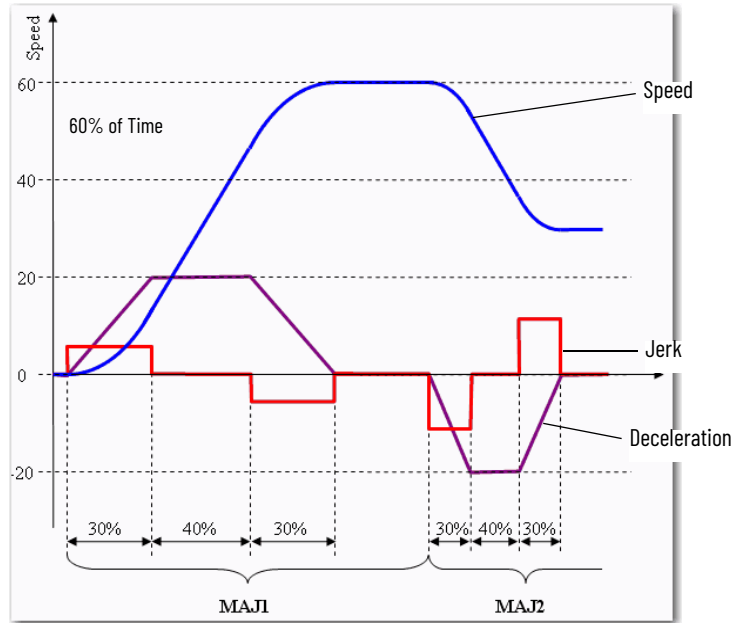

The motion planner algorithm adjusts the actual jerk rate so that both the acceleration profile and the deceleration profile contain at least the '% of time' ramp time. If the Start Speed is close to the programmed Speed parameter, the actual percentage of ramp time can be higher than the programmed value.

In most cases, the condition is:

- if: (start Speed is == 0.0) OR (start Speed is > 2 \* max Speed).
- then: you get **programmed** percentage of ramp time
- else: you get **higher than programmed** percentage of ramp time

### Conversion from % Time to Engineering Units

If you want to convert % of Time to Engineering Units, use these equations.

For Accel Jerk:

$$j_a [\% \text{ of Time}] = \frac{2}{1 + \frac{j_a [\text{EU/s}^3] v_{\text{max}} [\text{EU/s}]}{a_{\text{max}} [\text{EU/s}^2]}} 100$$

For Decel Jerk:

$$j_d [\% \text{ of Time}] = \frac{2}{1 + \frac{j_d [\text{EU/s}^3] v_{\text{max}} [\text{EU/s}]}{d_{\text{max}} [\text{EU/s}^2]}} 100$$

### Jerk Programming in Units/Sec<sup>3</sup>

If you want to specify the jerk in 'Units/sec<sup>3</sup>' instead of '% of time', adjust your jerk value as follows so that you get the value that you programmed.

$$\text{Temporary Speed} = \frac{\text{Programmed Decel Rate}^2}{\text{Desired Decel Jerk value in Units/Sec}^3}$$

$$k = \frac{\text{Start Speed} - \text{Programmed Speed}}{\text{Max}(\text{Programmed Speed}, \text{Temporary Speed})}$$

if ( $k < 1$ )

- Instruction Faceplate Decel Jerk in Units/Sec<sup>3</sup> = Desired Decel Jerk in Units/Sec<sup>3</sup>
- else
- Instruction Faceplate Decel Jerk in Units/Sec<sup>3</sup> = Desired Decel Jerk in Units/Sec<sup>3</sup> \* k

### Unique Program Considerations

If you program a move by using the **% of Time** units, the programming software computes an **Accel Jerk** =  $a^2/v$  where a = the programmed **Accel Rate** and v = programmed **Speed**.

Therefore, the higher the programmed speed, the lower the computed Jerk. The system has a Jerk priority planner. In other words, Jerk always takes priority over acceleration and velocity.

Therefore, you always get the programmed Jerk. If a move is velocity-limited, the move does not reach the programmed acceleration and/or velocity. Once you reach the velocity limit for the length of the move, as the velocity is increased, the move takes longer and longer to complete.

**Decel Jerk** is computed similarly to the Accel Jerk described previously. The only difference is that instead of  $a^2/v$ , Decel Jerk =  $d^2/v$ , where d = the programmed **Decel Rate**.

---

#### EXAMPLE

Example #1

Start Speed = 8.0 in/sec

Desired Speed = 5.0 in/sec

Desired Decel Rate = 2.0 in/sec<sup>2</sup>

Desired Decel Jerk = 1.0 in/sec<sup>3</sup>

Temporary Speed = (Desired Decel Rate)<sup>2</sup> / Desired jerk value in  
Units/Sec<sup>3</sup> = 2.0<sup>2</sup> / 1.0 =  
= 4.0 in/sec

$k = (8.0 - 5.0) / \text{max}(5.0, 4.0) = 3.0 / 5.0 =$   
= 0.6

Because  $k < 1$ , we can enter the desired Decel jerk directly in the  
faceplate

Instruction faceplate Decel jerk in Units/Sec<sup>3</sup> = 1.0 in/sec<sup>3</sup>

---

---

**EXAMPLE** Example #2  
 Start Speed = 13.0 in/sec  
 Desired Speed = 5.0 in/sec  
 Desired Decel Rate = 2.0 in/sec<sup>2</sup>  
 Desired Decel Jerk = 1.0 in/sec<sup>3</sup>  
 Temporary Speed = (Desired Decel Rate)<sup>2</sup> / Desired jerk value in  
 Units/Sec<sup>3</sup> = 2.0<sup>2</sup> / 1.0 =  
 = 4.0 in/sec  
 $k = (13.0 - 5.0) / \max(5.0, 4.0) = 8.0 / 5.0 =$   
 = 1.6  
 Because  $k > 1$ , we have to calculate the Decel jerk to use on the  
 instruction faceplate as:  
 Instruction faceplate Decel jerk in Units/Sec<sup>3</sup> =  
 = 1.0 in/sec<sup>3</sup> \* 1.6 =  
 = 1.6 in/sec<sup>3</sup>

---

Which revision do you have?

- 15 or earlier: % of Time is fixed at 100.
- 16 or later: % of Time defaults to 100% of time on projects that are converted from earlier versions. For new projects, you must enter the Jerk value.

## Profile Operand

This operand has two profile types:

- [Trapezoidal Velocity Profile](#)
- [S-curve Velocity Profile](#)

### Trapezoidal Velocity Profile

The trapezoidal velocity profile is the most commonly used profile because it provides the most flexibility in programming subsequent motion and the fastest acceleration and deceleration times. Acceleration and deceleration specify the change in velocity per unit time. Jerk is not a factor for trapezoidal profiles. Therefore, it is considered infinite and is shown as a vertical line in the following graph.

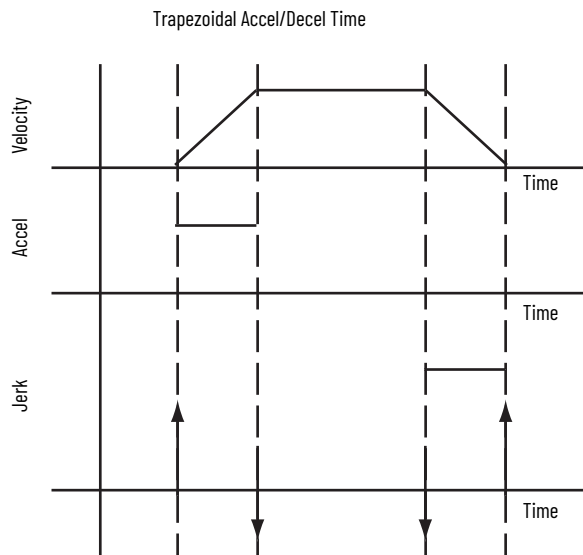

### S-curve Velocity Profile

S-curve velocity profiles are most often used when the stress on the mechanical system and load must be minimized. The acceleration and deceleration time is balanced against the machine stress with two additional parameters, acceleration jerk and deceleration jerk.

The acceleration profile can be set to almost pure rectangular, see [Trapezoidal Accel/Decel Time on page 203](#) (fastest and highest stress), or to triangular, see [Programmable S-curve Accel/Decel Time, Acceleration Jerk = 60% of Time on page 205](#) (slowest, lowest stress), dependent on the Jerk settings.

The typical acceleration profile is a trade-off between stress and speed, as shown in [S-curve Accel/Decel Time, Backward Compatibility Setting: Acceleration Jerk = 100% of Time on page 205](#).

Either you specify the Jerk (either in Units/sec<sup>3</sup> or as a percentage of maximum) or it is calculated from the percentage of time. (Percentage of time is equal to the percentage of ramp time in the acceleration/deceleration profile).

$$j_a [EU/s^3] = \frac{a_{max}^2 [EU/s^2]}{v_{max} [EU/s]} \left( \frac{200}{j_a [\% \text{ of time}]} \right)^{-1}$$

$$j_d [EU/s^3] = \frac{d_{max}^2 [EU/s^2]}{v_{max} [EU/s]} \left( \frac{200}{j_d [\% \text{ of time}]} \right)^{-1}$$

### Backward Compatibility

The Jerk of 100% of time produces triangular acceleration and deceleration profiles. These profiles are ones that would have been previously produced as shown in [S-curve Accel/Decel Time, Backward Compatibility Setting: Acceleration Jerk = 100% of Time on page 205](#).

Small Jerk rates, rates less than 5% of time, produce acceleration and deceleration profiles close to rectangular ones, such as the one shown in [Trapezoidal Accel/Decel Time on page 203](#).

**IMPORTANT** Higher values of the % of Time result in lower values of Jerk Rate Limits and, therefore, slower profiles. See [Table 57](#) for reference.

Table 57 - Velocity Versus Jerk

	Trapezoidal Velocity Profile <sup>(1)</sup>	S-shaped Velocity Profile with Jerk <100% of Time <sup>(2)</sup>	S-shaped Velocity Profile with Jerk = 100% of Time <sup>(3)</sup>
Accel/Decel Jerk in Units/sec <sup>3</sup>	¥	$\frac{\text{Max Accel}^2}{\text{Max Velocity}}$ to $\infty$	$\frac{\text{Max Accel}^2}{\text{Max Velocity}}$
Accel/Decel Jerk in % of Maximum	—	0...100%	—
Accel/Decel Jerk in % of Time	0%	1...100%	100%

(1) The example on [page 203](#) (labeled Trapezoidal Accel/Decel Time) uses a rectangular acceleration profile.  
 (2) The example on [page 205](#) (labeled Programmable S-curve Accel/Decel Time, Acceleration Jerk = 60% of Time) uses a trapezoidal acceleration profile.  
 (3) The example on [page 205](#) (labeled S-curve Accel/Decel Time, Backward Compatibility Setting: Acceleration Jerk = 100% of Time) uses a triangular acceleration profile.

Calculations are performed when an Axis Move, Change Dynamics, or an MCS™ Stop of StopType = Move or Jog is initiated.

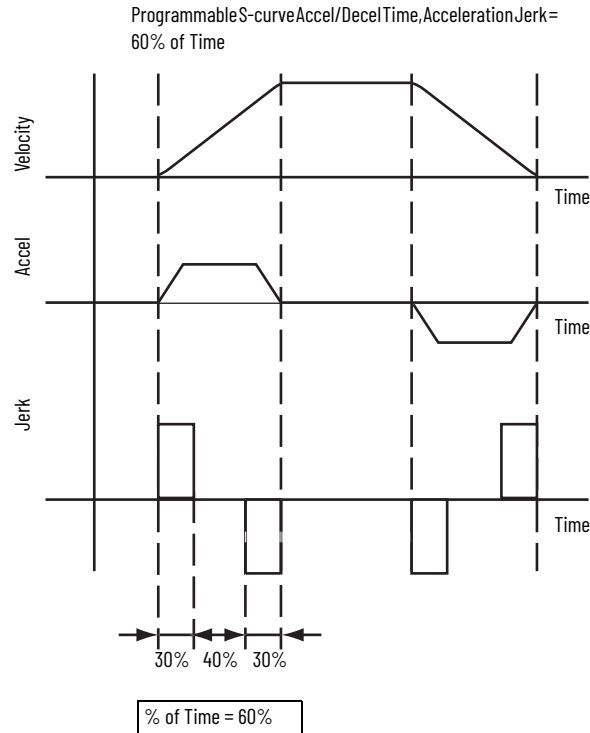

S-curve Accel/Decel Time, Backward Compatibility Setting: Acceleration Jerk = 100% of Time

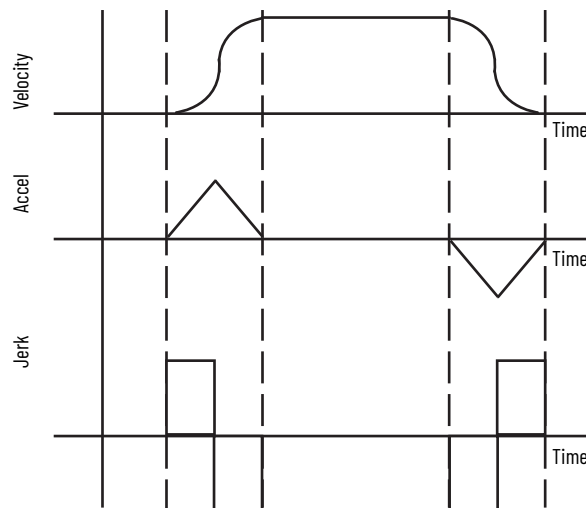

## Enter Basic Logic

The controller gives you a set of motion control instructions for your axes:

- Use these instructions just like the rest of the Studio 5000 Logix Designer® application instructions. You can program motion control in these programming languages:
  - Ladder diagram (LD)
  - Structured Text (ST)
  - Sequential Function Chart (SFC)
- Each motion instruction works on one or more axes.

- Each motion instruction needs a motion control tag. The tag uses a MOTION\_INSTRUCTION data type. The tag stores the status information of the instruction.

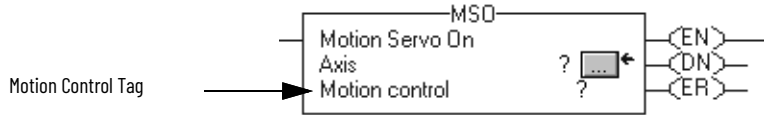

**ATTENTION:** Use the tag for the motion control operand of motion instruction only once. Unintended operation of the control variables can happen if you reuse the same motion control tag in other instructions.

### Example Motion Control Program

This figure is an example of ladder logic that homes, jogs, and moves an axis.

If *Initialize\_Pushbutton* = on and the axis = off (*My\_Axis\_X.ServoActionStatus* = off) then the MSO instruction turns on the axis.

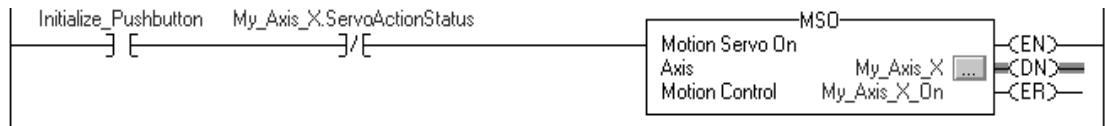

If *Home\_Pushbutton* = on and the axis hasn't been homed (*My\_Axis\_X.AxisHomedStatus* = off) then the MAH instruction homes the axis.

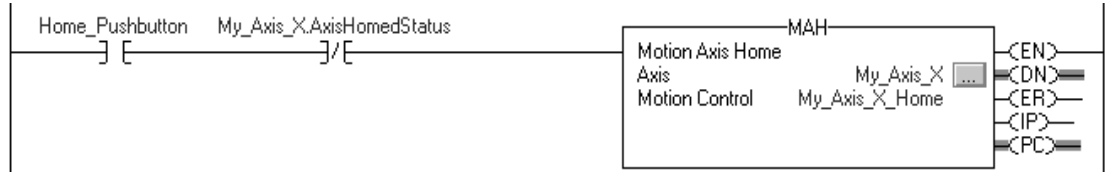

If *Jog\_Pushbutton* = on and the axis = on (*My\_Axis\_X.ServoActionStatus* = on) then the MAJ instruction jogs the axis forward at 8 units/s.

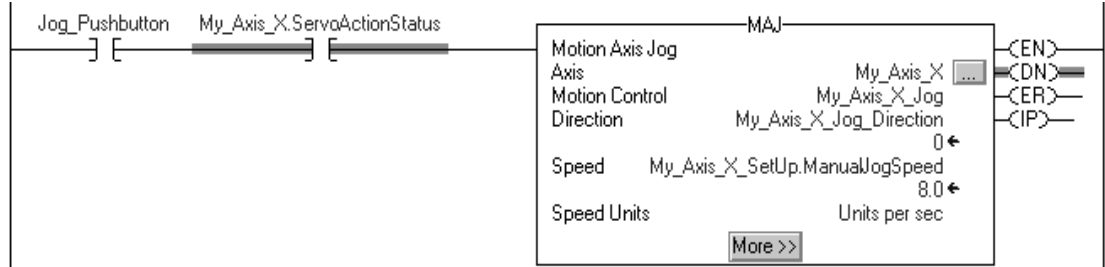

If *Jog\_Pushbutton* = off then the MAS instruction stops the axis at 100 units/s<sup>2</sup>. Make sure that *Change Decel* is Yes. Otherwise, the axis decelerates at its maximum speed.

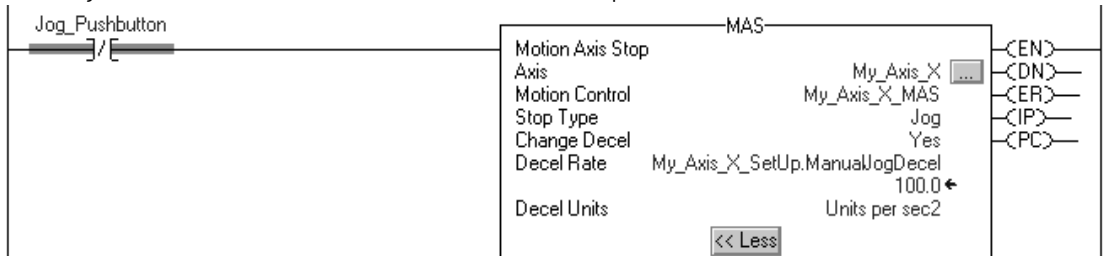

If *Move\_Command* = on and the axis = on (*My\_Axis\_X.ServoActionStatus* = on) then the MAM instruction moves the axis. The axis moves to the position of 10 units at 1 unit/s.

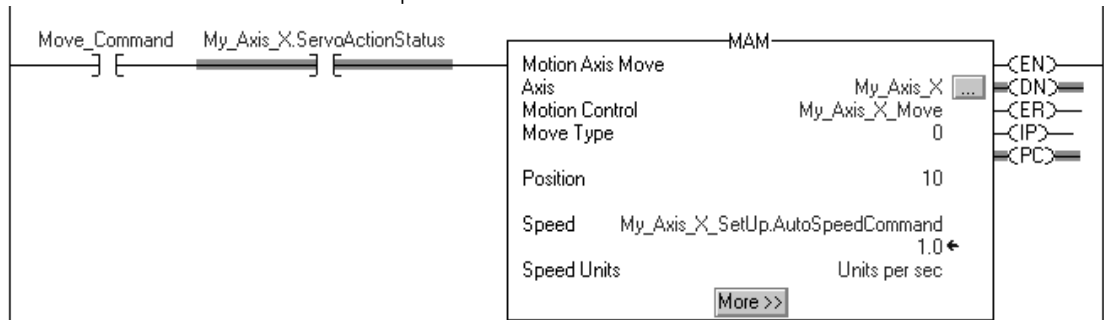

### Download a Project

Follow these steps to download your program to a controller.

1. With the keyswitch, place the controller in Program or Remote Program mode.
2. From the Communications menu, choose Download.
3. Confirm that you wish to complete the download procedure.
4. Click Download.
5. Once the download is complete, place the controller in Run/Test mode.

After the project file is downloaded, status and compiler messages appear in the status bar.

### Choose a Motion Instruction

Use [Table 58](#) to choose an instruction and see if it is available as a Motion Direct Command.

**Table 58 - Available Motion Direct Commands**

If You Want To	And	Use This Instruction	Motion Direct Command
Change the state of an axis	Enable the drive and activate the axis loop.	MSO Motion Servo On	Yes
	Disable the drive and deactivate the axis loop.	MSF Motion Servo Off	Yes
	Force an axis into the shutdown state and block any instructions that initiate axis motion.	MASD Motion Axis Shutdown	Yes
	Reset the axis from the shutdown state.	MASR Motion Axis Shutdown Reset	Yes
	Activate the drive control loops for the Integrated Motion on EtherNet/IP network axis and run the motor at the specified speed.	MDS Motion Drive Start	—
	Clear all motion faults for an axis.	MAFR Motion Axis Fault Reset	Yes

Table 58 - Available Motion Direct Commands (Continued)

If You Want To	And	Use This Instruction	Motion Direct Command
Control axis position	Stop any motion process on an axis.	MAS Motion Axis Stop	Yes
	Home an axis.	MAH Motion Axis Home	Yes
	Jog an axis.	MAJ Motion Axis Jog	Yes
	Move an axis to a specific position.	MAM Motion Axis Move	Yes
	Start electronic gearing between two axes.	MAG Motion Axis Gear	Yes
	Change the speed, acceleration, or deceleration of a move or a jog that is in progress.	MCD Motion Change Dynamics	Yes
	Change the command or actual position of an axis.	MRP Motion Redefine Position	Yes
	Calculate a Cam Profile that is based on an array of cam points.	MCCP Motion Calculate Cam Profile	No
	Start electronic camming between two axes.	MAPC Motion Axis Position Cam	No
	Start electronic camming as a function of time.	MATC Motion Axis Time Cam	No
Calculate the slave value, slope, and derivative of the slope for a cam profile and master value.	MCSV Motion Calculate Slave Values	No	
Initiate action on all axes	Stop motion of all axes.	MGS Motion Group Stop	Yes
	Force all axes into the shutdown state.	MGSD Motion Group Shutdown	Yes
	Transition all axes to the ready state.	MGSR Motion Group Shutdown Reset	Yes
	Latch the current command and actual position of all axes.	MGSP Motion Group Strobe Position	Yes
Arm and disarm special event checking functions, such as registration and watch position	Arm the watch-position event checking for an axis.	MAW Motion Arm Watch Position	Yes
	Disarm the watch-position event checking for an axis.	MDW Motion Disarm Watch Position	Yes
	Arm the module registration-event checking for an axis.	MAR Motion Arm Registration	Yes
	Disarm the module registration-event checking for an axis.	MDR Motion Disarm Registration	Yes
	Arm an output cam for an axis and output.	MAOC Motion Arm Output Cam	No
	Disarm one or all output cams connected to an axis.	MDOC Motion Disarm Output Cam	No

Table 58 - Available Motion Direct Commands (Continued)

If You Want To	And	Use This Instruction	Motion Direct Command
Tune an axis and run diagnostic tests for your control system. These tests include the following: <ul style="list-style-type: none"> <li>• Motor/encoder hookup test</li> <li>• Encoder hookup test</li> <li>• Marker test</li> </ul> Control multi-axis coordinated motion	Run a tuning motion profile for an axis	MRAT Motion Run Axis Tuning	No
	Run one of the diagnostic tests on an axis.	MRHD Motion Run Hookup Diagnostic	No
	Start a linear coordinated move for the axes of a coordinate system.	MCLM Motion Coordinated Linear Move	No
	Start a circular move for the axes of a coordinate system.	MCCM Motion Coordinated Circular Move	No
	Change in path dynamics for the active motion on a coordinate system.	MCCD Motion Coordinated Change Dynamics	No
	Stop the axes of a coordinate system or cancel a transform.	MCS Motion Coordinated Stop	No
	Shut down the axes of a coordinate system.	MCS D Motion Coordinated Shutdown	No
	Start a transform that links two coordinate systems together. This transform is like bidirectional gearing.	MCT Motion Coordinated Transform <sup>(1)</sup>	No
	Calculate the position of one coordinate system regarding another coordinate system.	MCTP Motion Calculate Transform Position <sup>(1)</sup>	No
	Transition the axes of a coordinate system to the ready state and clear the axis faults.	MCSR Motion Coordinated Shutdown Reset	No
Run a motor test to measure motor model parameters.	MRMT Motion Run Motor Test		

(1) You can only use this instruction with ControlLogix® 5560 or GuardLogix® 5560 controllers.

## Troubleshoot Axis Motion

This section helps you troubleshoot some situations that could happen while you are running an axis.

Example Situation	Page
Why Does My Axis Accelerate When I Stop It?	210
Why Does My Axis Overshoot Its Target Speed?	211
Why Is There a Delay When I Stop and Then Restart a Jog?	213
Why Does The Axis Reverse Direction When Stopped and Started?	214

## Why Does My Axis Accelerate When I Stop It?

While an axis is accelerating, you try to stop it. The axis accelerates for a short time before it starts to decelerate.

### Example

You start a Motion Axis Jog (MAJ) instruction. Before the axis gets to its target speed, you start a Motion Axis Stop (MAS) instruction. The axis continues to speed up and then eventually slows to a stop.

### Look For

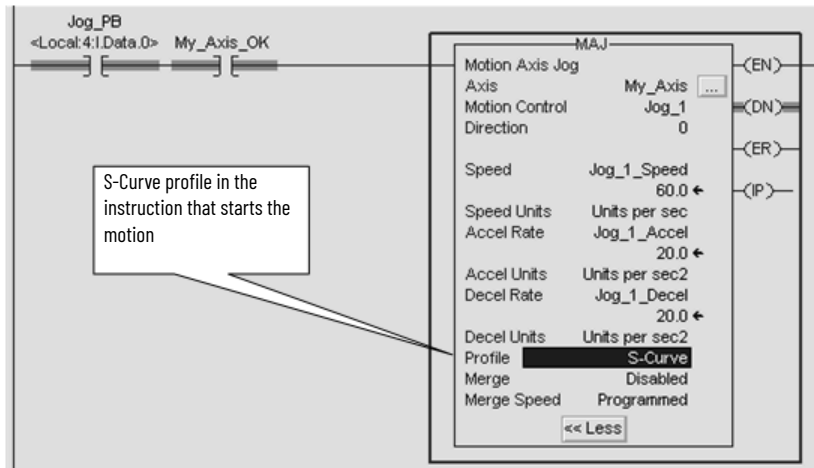

### Cause

When you use an S-curve profile, jerk determines the acceleration and deceleration time of the axis:

- An S-curve profile has to get acceleration to 0 before the axis can slow down.
- The time that it takes depends on the acceleration and speed.
- In the meantime, the axis continues to speed up.

The following trends show how the axis stops with a trapezoidal profile and an S-curve profile.

### Stop While Accelerating

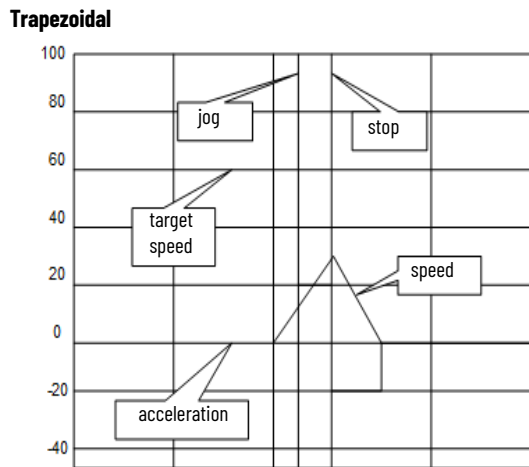

The axis slows down as soon as you start the stopping instruction.

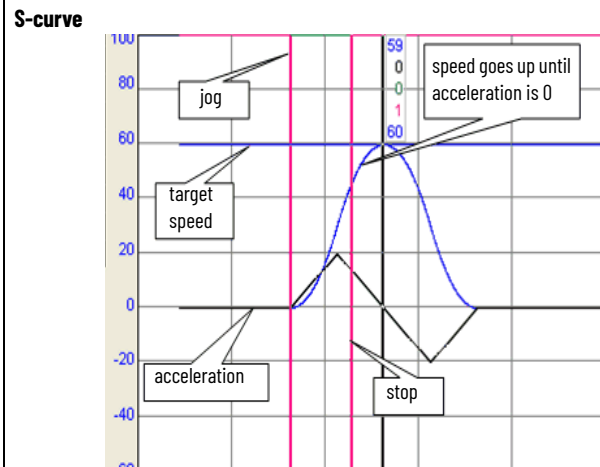

The axis continues to speed up until the S-curve profile brings the acceleration rate to 0.

## Corrective Action

If you want the axis to slow down right away, use a trapezoidal profile.

## Why Does My Axis Overshoot Its Target Speed?

While an axis is accelerating, you try to stop the axis or change its speed. The axis accelerates and goes past its initial target speed. Eventually it starts to decelerate.

### Example

You start a Motion Axis Jog (MAJ) instruction. Before the axis gets to its target speed, you try to stop it with another MAJ instruction. The speed of the second instruction is set to 0. The axis continues to speed up and overshoots its initial target speed. Eventually it slows to a stop.

### Look For

The top screenshot shows a MAJ instruction configuration window. The Speed is set to 60.0 and the Accel Rate is set to 20.0. A callout box points to the Accel Rate field with the text: "The MAJ instruction that starts the axis has a higher acceleration rate than the instruction that stops the axis." Another callout box points to the Profile field, which is set to S-Curve, with the text: "S-curve profile".

The bottom screenshot shows a MAJ instruction configuration window. The Speed is set to 0.0 and the Accel Rate is set to 10.0. A callout box points to the Accel Rate field with the text: "The MAJ instruction that stops the axis has a lower acceleration rate than the instruction that starts the axis." Another callout box points to the Profile field, which is set to S-Curve, with the text: "S-curve profile".

### Cause

When you use an S-curve profile, jerk determines the acceleration and deceleration time of the axis:

- An S-curve profile has to get acceleration to 0 before the axis can slow down.
- If you reduce the acceleration, it takes longer to get acceleration to 0.
- In the meantime, the axis continues past its initial target speed.

The following trends show how the axis stops with a trapezoidal profile and an S-curve profile.

**Stop While Accelerating and Reduce the Acceleration Rate**

**Trapezoidal**

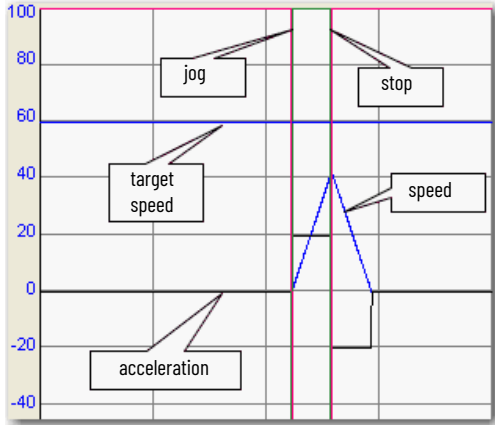

The axis slows down as soon as you start the stopping instruction. The lower acceleration doesn't change the response of the axis.

**S-curve**

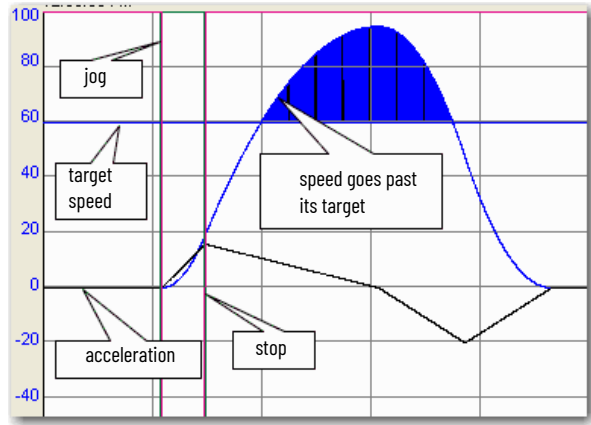

The stopping instruction reduces the acceleration of the axis. It now takes longer to bring the acceleration rate to 0. The axis continues past its target speed until acceleration equals 0.

*Corrective Action*

Use a Motion Axis Stop (MAS) instruction to stop the axis or configure your instructions like this example.

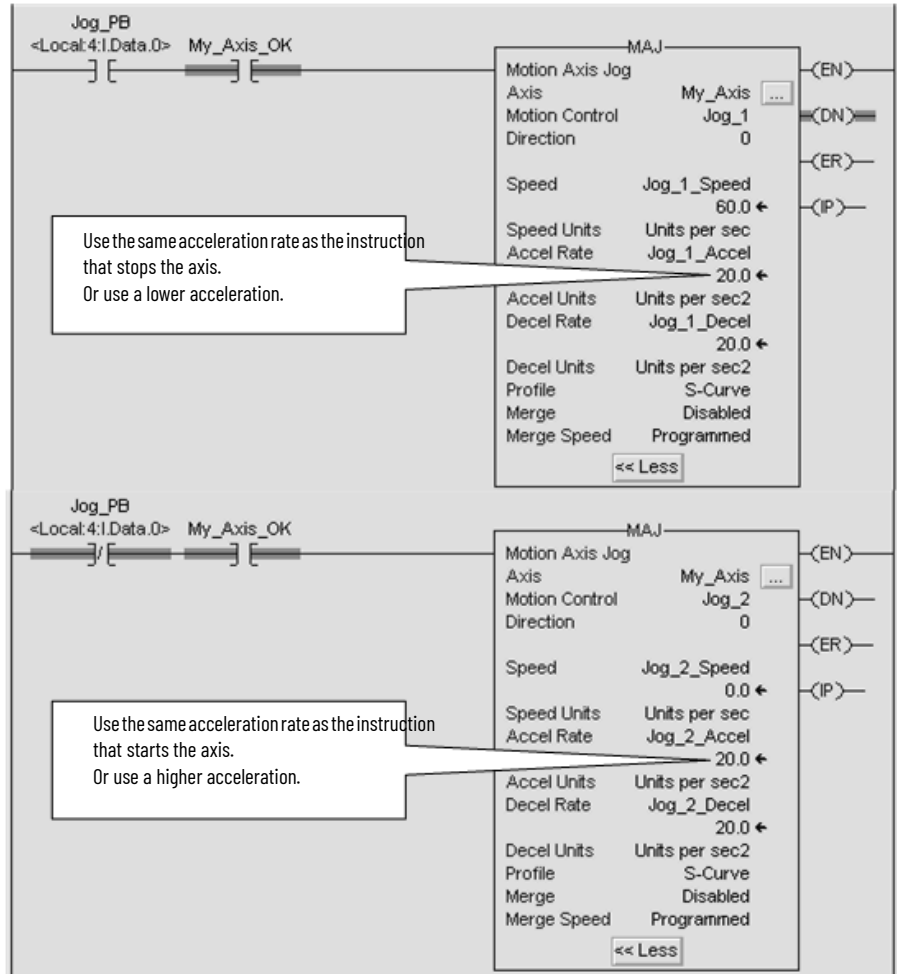

## Why Is There a Delay When I Stop and Then Restart a Jog?

While an axis is jogging at its target speed, you stop the axis. Before the axis stops completely, you restart the jog. The axis continues to slow down before it speeds up.

### Example

You use a Motion Axis Stop (MAS) instruction to stop a jog. While the axis is slowing down, you use a Motion Axis Jog (MAJ) instruction to start the axis again. The axis doesn't respond right away. It continues to slow down. Eventually it speeds back up to the target speed.

### Look For

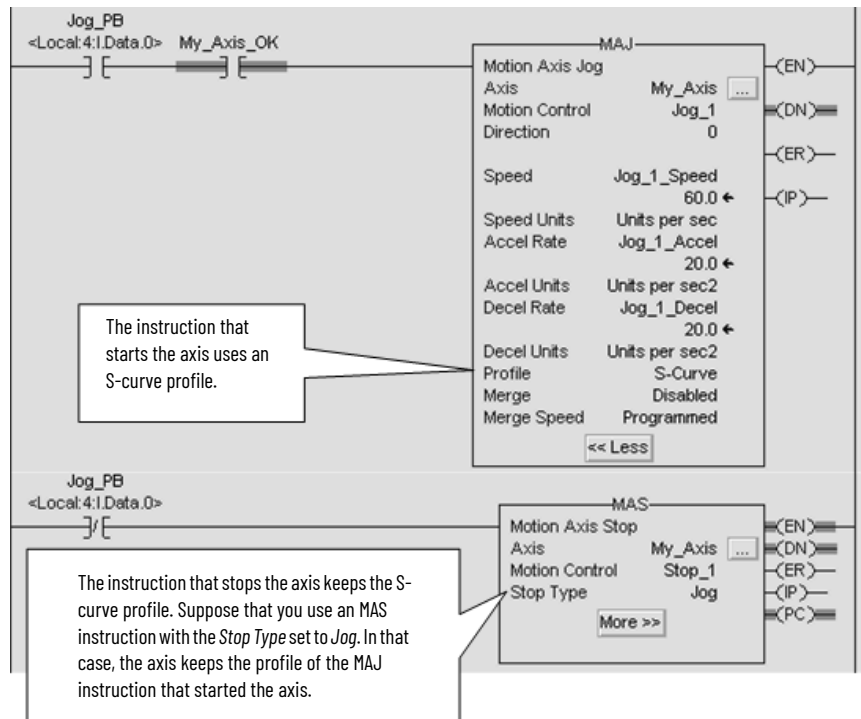

*Cause*

When you use an S-curve profile, jerk determines the acceleration and deceleration time of the axis. An S-curve profile has to get acceleration to 0 before the axis can speed up again. The following trends show how the axis stops and starts with a trapezoidal profile and an S-curve profile.

**Start While Decelerating**

**Trapezoidal**

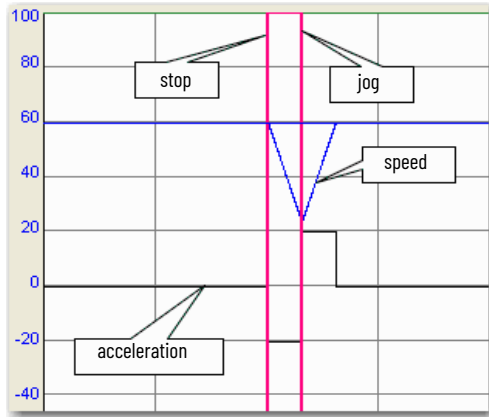

The axis speeds back up as soon as you start the jog again.

**S-curve**

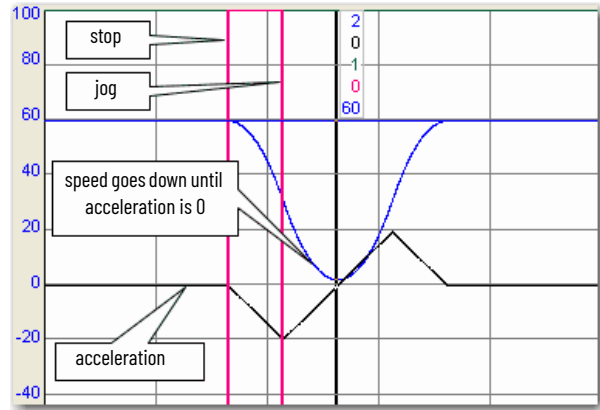

The axis continues to slow down until the S-curve profile brings the acceleration rate to 0.

*Corrective Action*

If you want the axis to accelerate right away, use a trapezoidal profile.

**Why Does The Axis Reverse Direction When Stopped and Started?**

While an axis is jogging at its target speed, you stop the axis. Before the axis stops completely, you restart the jog. The axis continues to slow down and then reverses direction. Eventually the axis changes direction again and moves in the programmed direction.

*Example*

You use a Motion Axis Stop (MAS) instruction to stop a jog. While the axis is slowing down, you use a Motion Axis Jog (MAJ) instruction to start the axis again. The axis continues to slow down and then moves in the opposite direction. Eventually it returns to its programmed direction.



### Corrective Action

Use the same deceleration rate in the instruction that starts the axis and the instruction that stops the axis.

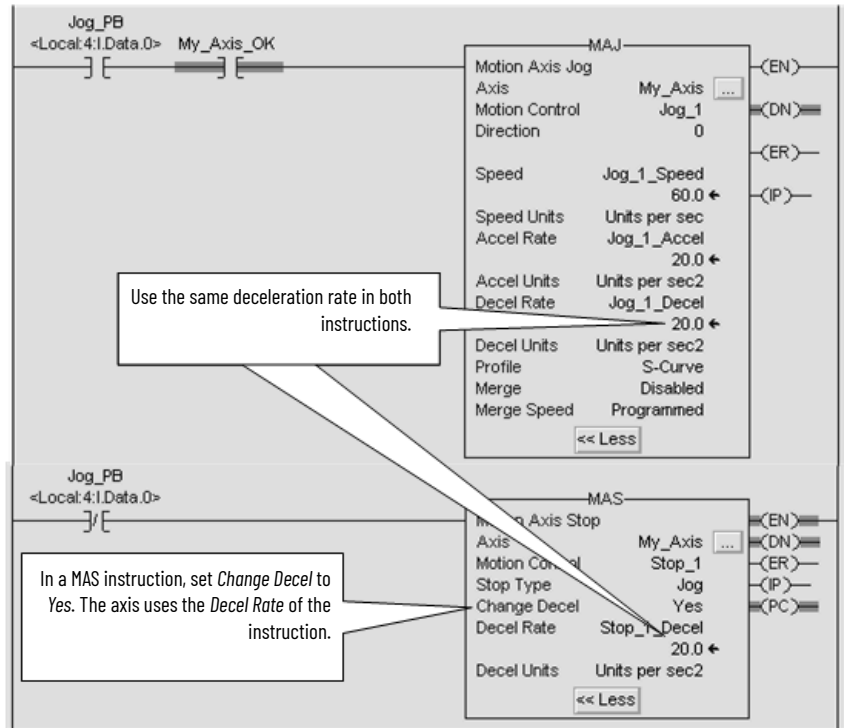

## Programming with the MDSC Function

Figure 103 shows an example of programming motion with the MDSC functionality. In this example, we illustrate a 50.0 mm move.

Figure 103 - Slave Speed Control from Master with Lock Position, MDSC Time Based

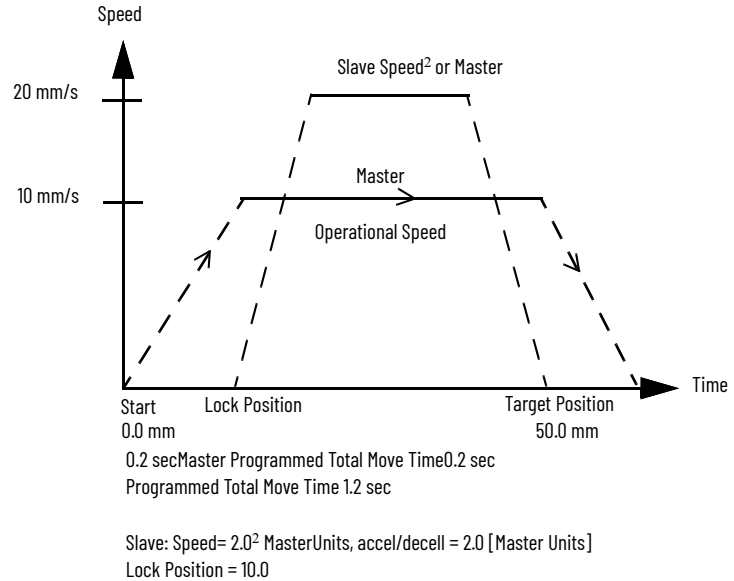

Table 59 - Comparison of the Enumerations for the Motion Instructions

Revision	Operand	Units	Type	Profile
V19 and earlier	Speed	Units/sec	Rate	Trapezoidal, S-curve
(PJerk)	Accel/Decel	Units/sec <sup>2</sup>	Rate	—
	Jerk	Units/sec <sup>3</sup>	Rate	—
		% of time	Time	—
	Speed, Accel/Decel, and Jerk	% of max % of units/sec	Rate	—
For instructions: MAM, MAJ, MCD, and MAS				
V20	Speed	Units/sec	Rate	Trapezoidal, S-curve
		Sec	Time	Trapezoidal, S-curve
		Master units	Feedback	Trapezoidal, S-curve
	Accel/Decel	Units/sec <sup>2</sup>	Rate	Trapezoidal, S-curve
		Sec	Time	Trapezoidal, S-curve
		Master units	Feedback	Trapezoidal, S-curve
	Jerk	Units/sec <sup>2</sup>	Rate	Trapezoidal, S-curve
		Sec	Time	Trapezoidal, S-curve
		Master units	Feedback	Trapezoidal, S-curve
For instructions, MDSC, MAM, MAJ, and MATC				

In Figure 104, we are programming rate. The controller calculates the time of the move: Speed and Accel/Decel as units = units (seconds).

In Figure 105, we are programming time. The controller calculates the speed of the move: Speed and Accel/Decel as time [seconds].

Figure 104 - Programming Rate in RSLogix 5000® Software Version 19 and Earlier

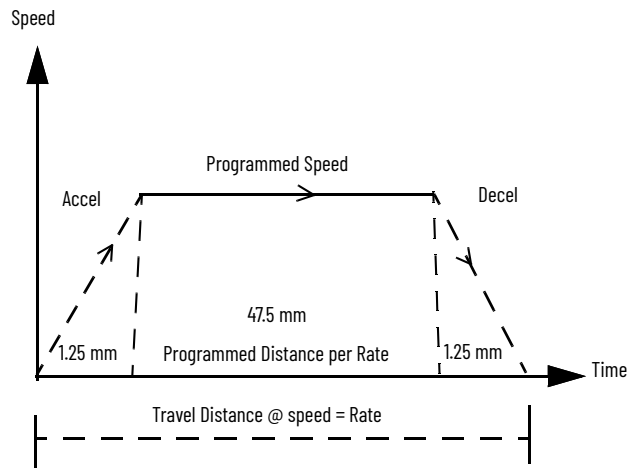

Start 0.0 End = 50.0 mm Speed = 10 mm/sec Accel/Decel = 40.0 mm/sec<sup>2</sup>  
 Equivalent to: DistanceRate

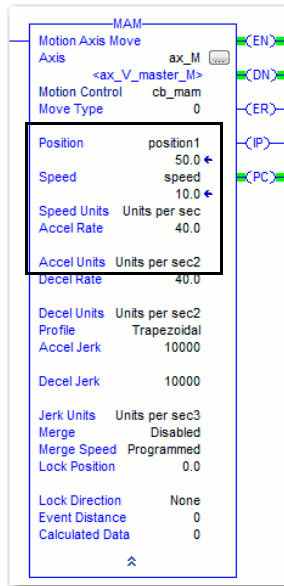

RSLogix 5000 software version 19 and earlier MAM instruction programmed as rate.

- Position 50.0 mm (start 0.0)
- Speed 10.0 mm/sec
- Accel 40.0 mm/sec<sup>2</sup>
- Decel 40.0 mm/sec<sup>2</sup>

So Travel\_Distance = area under the curve [ accel + at\_speed + decel ]  
 Travel\_Distance = 50 mm  
 Travel\_Distance = 50 mm [ 1.25 mm + 47.5 mm + 1.25 mm ]

Figure 105 - Programming Time in RSLogix 5000 Software Version 20 and Later

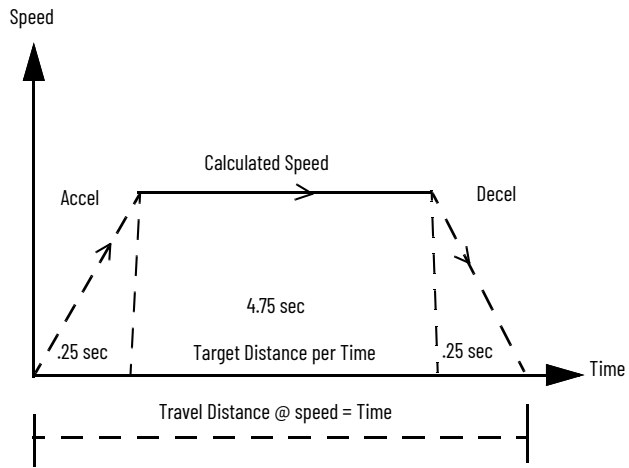

Start 0.0 End = 50.0 mm Speed = 10 mm/sec Accel/Decel = 0.25 sec  
 Equivalent to: DistanceTime

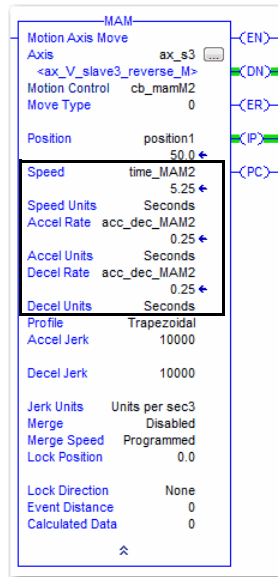

RSLogix 5000 software version 20 and later  
 MAM instruction programmed as time.

Position 50.0 mm (start 0.0)  
 Speed 5.25 sec  
 Accel 0.25 sec  
 Decel 0.25 sec

So Travel\_Distance = area under the  
 curve [ accel + at\_speed + decel ]  
 Travel\_Distance = 50 mm  
 Travel\_Time = 5.25 sec [ 0.25 + 4.75 + 0.25 sec ]

**Notes:**

## PowerFlex Out-of-Box Configuration

### Recommended Out-of-Box Settings

Apply these out-of-box settings first before configuring for your application. This information applies to only the PowerFlex® drive.

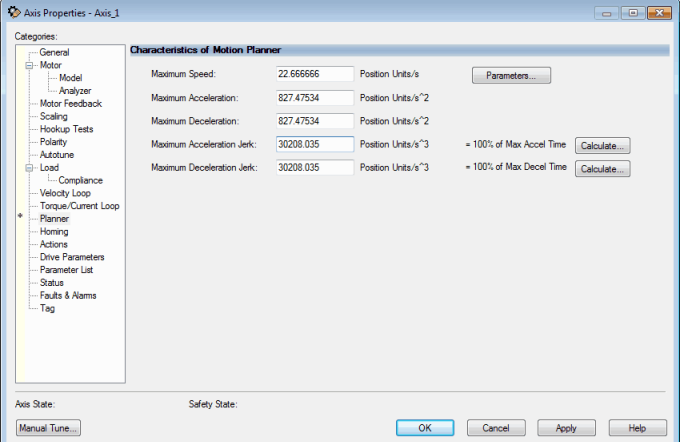
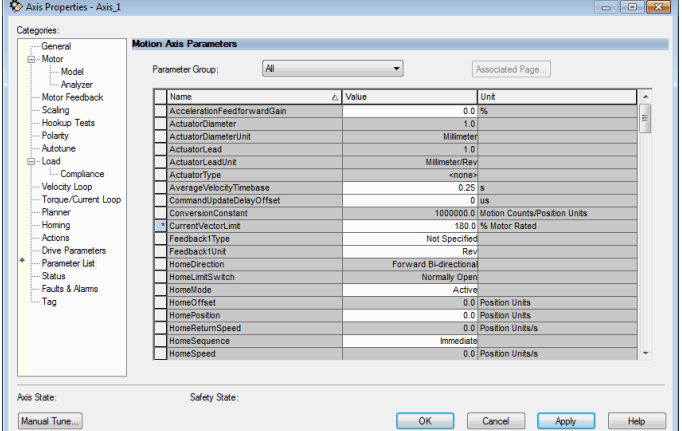
Settings in Studio 5000 Logix Designer® Application	Example	Recommended Configuration	
		PowerFlex 527	PowerFlex 755/755T
Ramp Velocity Limit		120% of Motor Rated Speed for Induction Motors	
Current Vector Limit		180% of Motor Rated Current	

Settings in Studio 5000 Logix Designer Application

Example

Recommended Configuration

PowerFlex 527

PowerFlex 755/755T

Torque Limits

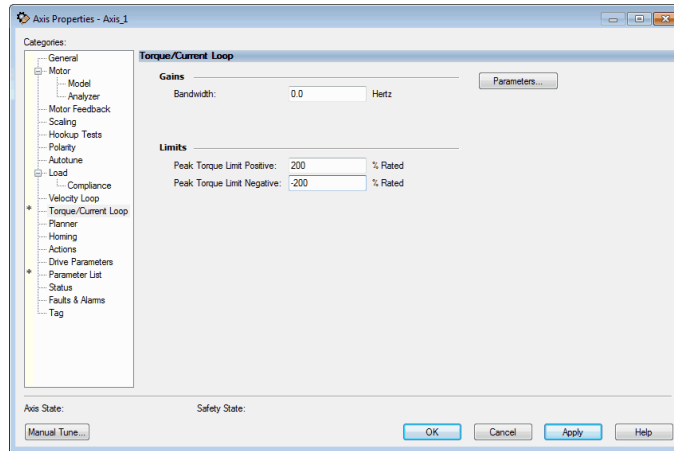

200% of Motor Rated Torque

Velocity Error Tolerance

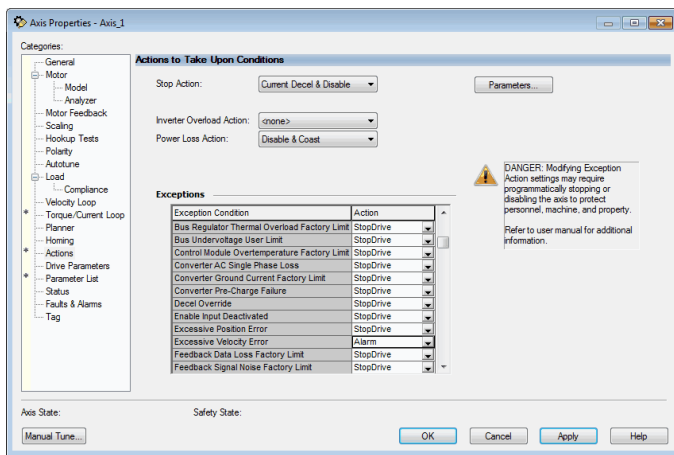

Change action to alarm

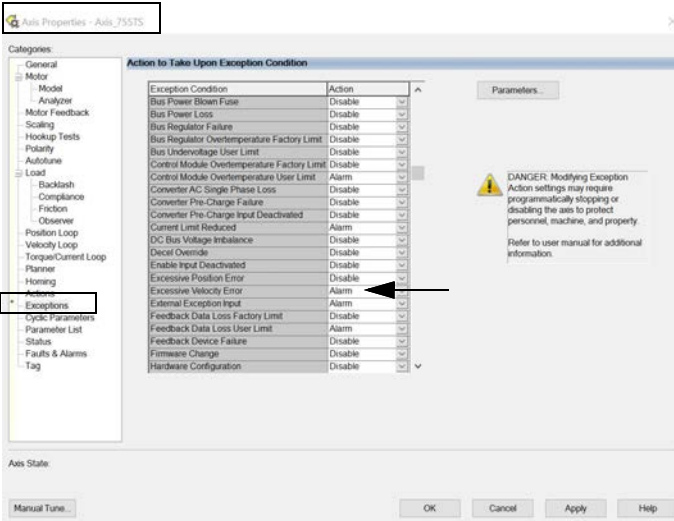

Settings in Studio 5000 Logix Designer Application

Example

Recommended Configuration

PowerFlex 527

PowerFlex 755/755T

Feedback Tap

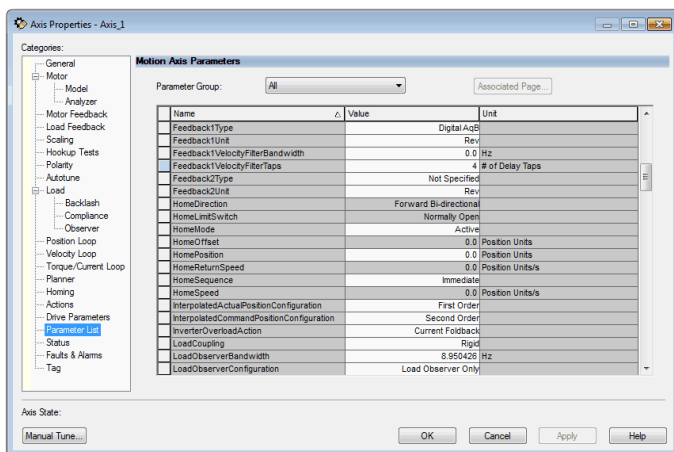

16

4<sup>(1)</sup>

Application Type setting in Velocity Loop

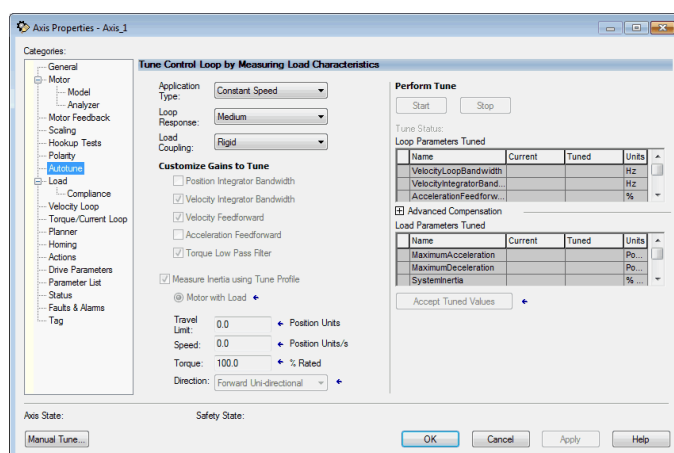

Constant Speed

Motion Group Base Update Rate

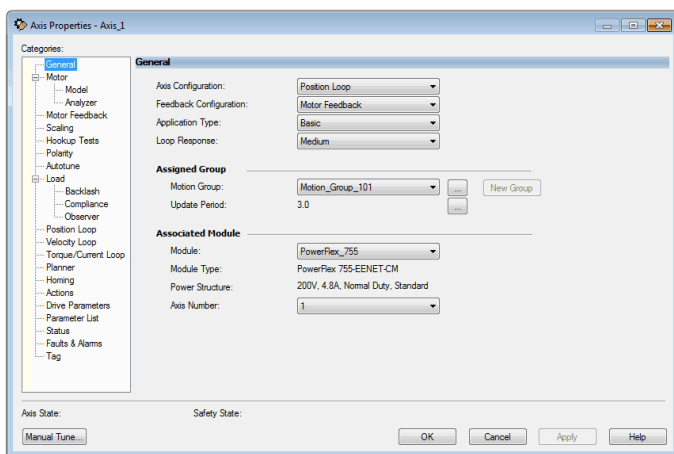

4 ms

3 ms (PowerFlex 755)  
2 ms (PowerFlex 755T)

(1) PowerFlex 755T drives do not support Feedback Tap.

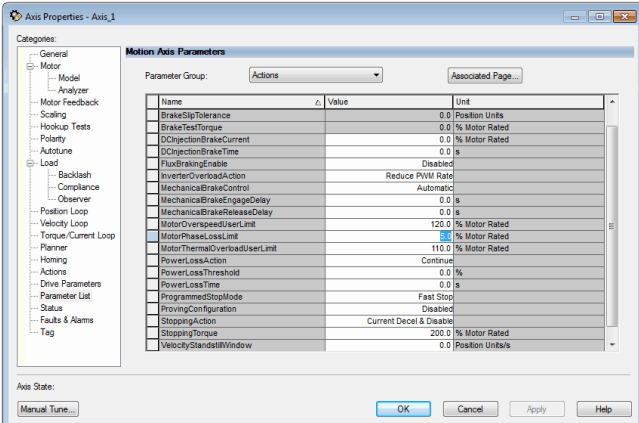
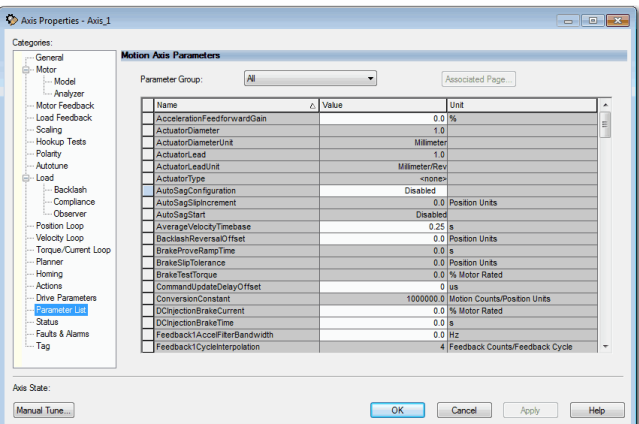
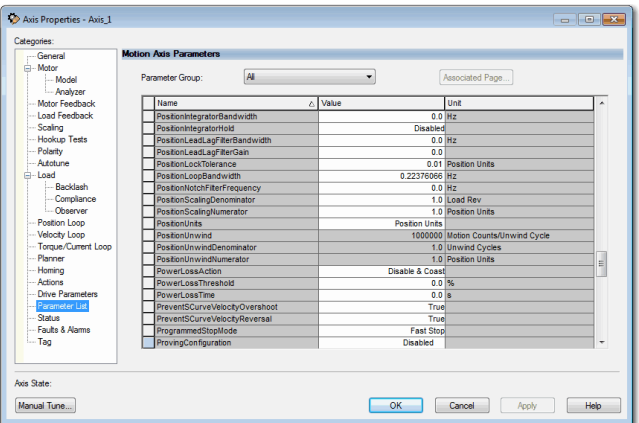
Settings in Studio 5000 Logix Designer Application	Example	Recommended Configuration
Motor Phase Loss Limit <sup>(1)</sup>		5% is the typical setting <sup>(2)</sup>
Auto Sag Configuration		Disabled <sup>(3), (4)</sup>
Proving Configuration		Disabled <sup>(5), (6)</sup>

- (1) You must use a value of 1% for MotorPhaseLossLimit if your configuration includes a Rotary Permanent Magnet Motor.
- (2) Change this parameter to 1% for only Rotary Permanent Magnet Motor configurations.
- (3) Auto Sag Configuration must be disabled for the out-of-box configuration to avoid unexpected operation. If you enable this parameter, it opens the Auto Sag Slip Increment and Auto Sag Start parameters for editing.
- (4) PowerFlex 755T drives do not support Auto Sag.
- (5) Proving Configuration must be disabled for the out-of-box configuration to avoid unexpected operation. If you enable this parameter, it opens the Brake Prove Ramp Time, Brake Slip Tolerance, and Brake Test Torque parameters for editing.
- (6) PowerFlex 755T drives do not support Torque Proving.

**IMPORTANT**

If your configuration includes a Rotary Permanent Magnet motor, you must change the Phase-Loss limit to 1 ms for operation. If you do not change the Phase-Loss limit to 1 ms, the Commutation Test for the Rotary PM could fail and generate a Motor Phase-Loss Limit fault. Also, the instruction MSO for the Rotary PM can fail and generate a Motor Phase-Loss Limit fault.

## Setting the ACO/AVO Attribute for PowerFlex 527 Drives Only

The attribute ACO/AVO (Analog Current Output/Analog Voltage Output) can be used to set the analog output of the PowerFlex 527 drive to either current (mA) or voltage (V).

Make sure that the Analog Out jumper (J2) is also set to the same value.

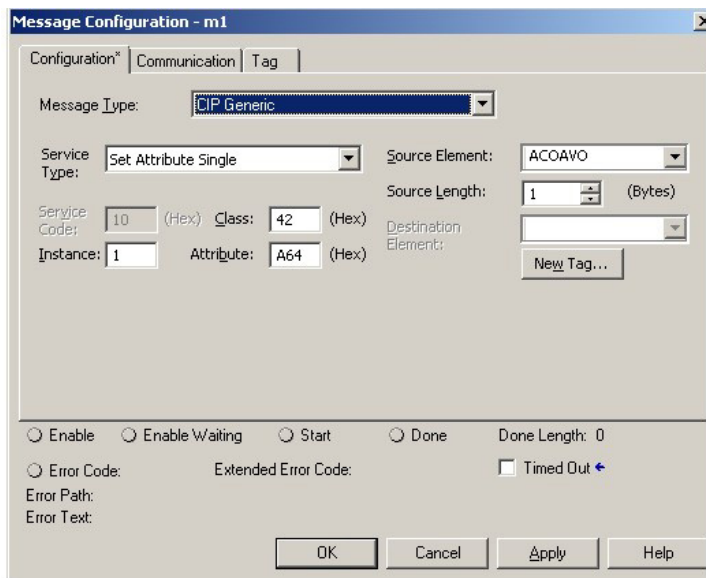

Table 60 - ACO/AVO:MSG

Parameter	Value	Description
Service Code	0x10	Get Attribute Single
Class	0x42	Analog Output
Instance	1	-
Attribute	0xA64	Voltage/Current Mode
Data Type	SINT	Unsigned Short Integer

Table 61 - ACO/AVO: Values

Value	Definition
0	Voltage (V)
1	Current (mA)

**Notes:**

The following terms and abbreviations are used throughout this manual. For definitions of terms that are not listed here, refer to the Allen-Bradley Industrial Automation Glossary, publication [AG-71](#).

<b>Absolute Position Retention (APR)</b>	While Homing creates an absolute machine reference position, the APR bit is designed to retain the absolute position.
<b>Axis</b>	A logical element of a motion control system that exhibits some form of movement. Axes can be rotary or linear, physical, or virtual, controlled, or observed.
<b>Axis Test Mode</b>	A feature that allows real-time motion control behavior to be simulated at the motion axis, motion module, or motion group level, without requiring or using a complete set of connected hardware.
<b>Bus Regulator</b>	Used to limit the rise in DC Bus voltage level that occurs when decelerating a motor.
<b>CIP™</b>	Common Industrial Protocol.
<b>CIP Sync™</b>	Defines extensions to CIP Common objects and device profiles to support time synchronization over CIP Networks.
<b>Closed-loop</b>	A method of control where there is a feedback signal that is used to drive the actual dynamics of the motor to match the commanded dynamics by servo action. In most cases, there is a literal feedback device to provide this signal, but in some cases the signal is derived from the motor excitation, for example, sensorless operation.
<b>Converter</b>	A device that generally converts AC input to DC output. A Converter is also commonly called the Drive Power Supply. In the context of a drive system, the Converter is responsible for converting AC Main input into DC Bus power.
<b>Course (Base) Update Period</b>	The base update period of the update task of the motion group, which is specified in milliseconds.
<b>Controller Loop Back</b>	In the Controller Loop Back mode, the command position that the motion planner generates is directly used as the actual position without communication to the drive.
<b>Cyclic Data Block</b>	A high priority real-time data block that is an integrated motion on the EtherNet/IP™ network connection transfers on a periodic basis.
<b>Drive</b>	A device that is designed to control the dynamics of a motor.
<b>Event Data Block</b>	A medium priority real-time data block that an integrated motion on the EtherNet/IP network connection transfers only after a specified event occurs. Registration and marker input transitions are typical drive events.
<b>Get/Read</b>	A Get/Read involves the retrieval of an attribute value from the perspective of the Controller side of the interface.
<b>Integrated Motion on the EtherNet/IP Network Drive</b>	The I/O connection is the periodic bidirectional, Class 1, CIP connection between a controller and a drive that is defined as part of the integrated motion on the EtherNet/IP network standard. Any drive device that complies with the integrated motion on the EtherNet/IP network standard.
<b>Inverter</b>	A device that generally converts DC input to AC output. An Inverter is also commonly called the Drive Amplifier. In the context of a drive system, the Inverter is responsible for controlling the application of DC Bus power to an AC motor.
<b>Motion</b>	Any aspect of the dynamics of an axis. In the context of this document, it is not limited to servo drives but encompasses all forms of drive-based motor control.
<b>Motion Group</b>	A user-defined grouping of motion axes. A motion group has configuration parameters and status attributes that apply to all axes in the group.

<b>Multiplexing</b>	The method by which multiple signals are combined into one signal for transmission.
<b>Multiplex Update Multiplier</b>	Number of multiplexed drives that determines the multiplex update period.
<b>Multiplex Update Period</b>	Task update period for a Multiplexed Axis.
<b>Open-loop</b>	A method of control where there is no application of feedback to force the actual motor dynamics to match the commanded dynamics. Examples of open-loop control are stepper drives and variable frequency drives.
<b>Safe Torque Off (STO)</b>	Provides a method, with a sufficiently low probability of failure, to force the power-transistor control signals to a disabled state. When the command to allow torque ceases from the GuardLogix <sup>®</sup> controller, all drive output-power transistors are released from the On-state.
<b>Service Data Block</b>	A lower priority real-time data block associated with a service message from the controller that an integrated motion on the EtherNet/IP network connection transfers on a periodic basis. Service data includes service request messages to access attributes, run a drive-based motion planner, or perform various drive diagnostics.
<b>Set/Write</b>	A Set/Write involves setting an attribute to a specified value from the perspective of the Controller side of the interface.
<b>Shunt Regulator</b>	A specific Bus Regulator method that switches the DC Bus across a power dissipating resistor to dissipate the regenerative power of a decelerating motor.
<b>Synchronized</b>	A condition where the local clock value on the drive is locked onto the master clock of the distributed System Time. When synchronized, the drive and controller devices can use time stamps that are associated with an integrated motion on the EtherNet/IP network connection data.
<b>System Time</b>	The absolute time value as defined in the CIP Sync standard in the context of a distributed time system where all devices have a local clock that is synchronized with a common master clock. In the context of integrated motion on the EtherNet/IP network, System Time is a 64-bit integer value in units of microseconds or nanoseconds with a value of 0 corresponding to January 1, 1970.
<b>Time Offset</b>	The System Time Offset value that is associated with the integrated motion on the EtherNet/IP network connection data that is associated with the source device. The System Time Offset is a 64-bit offset value that is added to the local clock of a device to generate System Time for that device.
<b>Time Stamp</b>	A system time stamp value that is associated with the integrated motion on the EtherNet/IP network connection data. The time stamp conveys the absolute time when the associated data was captured, or can be also used to determine when associated data is applied.
<b>Variable Frequency Drive (VFD)</b>	A class of drive products that seek to control the speed of a motor, typically an induction motor, through a proportional relationship between drive output voltage and commanded output frequency. Frequency drives are, therefore, sometimes referred to as Volts/Hertz drives.
<b>Vector Drive</b>	A class of drive products that seek to control the dynamics of a motor via closed-loop control. These dynamics include, but are not limited to, closed-loop control of both torque and flux vector components of the motor stator current relative to the rotor flux vector.

## Symbols

- % of time**
  - profile examples 198
  - use to program jerk 198

## Numerics

- 100 % of time jerk calculation** 204
- 1756-L6x**
  - APR 166
- 842E-CM**
  - configure feedback-only axis properties for Kinetix drives 87

## A

- absolute feedback device** 160
- absolute feedback position** 160
- absolute position** 155, 159, 160
- absolute position loss**
  - without APR fault 168
- active homing** 156
  - examples 156
- adaptive tuning** 137 - 141
- additional manual tuning parameters** 173 - 177
  - compensation parameters 174
  - feedforward parameters 174
  - filters parameters 175
  - limits parameters 176
  - planner parameters 177
  - torque parameters 177
- additional tune** 173 - 177
- alarms** 183 - 193
- APR**
  - absolute position recovery 159
  - fault 166
    - reset 168
  - fault conditions 164
  - fault generation 165
    - saving an ACD file versus uploading a project 167
  - faults 164
  - incremental encoders 168
  - position recovery considerations for Logix5000 controllers 160
  - recovery
    - battery backed controller 163
    - change controller 163
    - controller 162
    - controller and drives remained powered 162
    - download same program with no hardware changes 163
    - drive 164
    - feedback device 164
    - inhibit or uninhibit 164
    - position feedback 164
    - restore 164
    - RSLogix 5000 project 164

- scaling 164
- scenarios 161 - 164
- SERCOS versus integrated motion on Ethernet networks 161
- supported components 160
- terminology 160

### ArmorKinetix drive

- minimum version of Studio 5000 Logix Designer application 13
- supported axis types 13
- voltage ranges 13

### ArmorKinetix modules

- description 13

### associated products 9

### autotune 131

### availability of manual tuning

- per axis type 169

### available motion direct commands 207 - 209

### axis

- commission 119 - 145
- homed status bit 166
- inhibit 191
- tune 169

### axis configuration example

- Kinetix 5500 drive
  - velocity control with motor feedback 81
- Kinetix 5700 drive
  - frequency control with no feedback 85
- Kinetix drive using ControlLogix controller 87
- Kinetix drives
  - feedback only 78
  - position loop with dual feedback 74
  - position loop with motor feedback only 71
- PowerFlex 527 drive
  - frequency control with no feedback 109
  - position control with motor feedback 114
  - velocity control with motor feedback 112
- PowerFlex 755 drive
  - frequency control with no feedback 103
  - position loop with dual motor feedback via a UFB feedback device 93
  - position loop with motor feedback via a UFB feedback device 91
  - torque loop with feedback 106
  - velocity loop with motor feedback via a UFB feedback device 97
  - velocity loop with no feedback 101

### axis configuration examples

- Kinetix drives 71 - 89
- PowerFlex 527 drive 109 - 117
- PowerFlex 755 drive 91 - 108

### axis configuration types

- availability of manual tuning 169
- compare 43

### axis motion

- troubleshoot 209 - 216
  - axis accelerates when instructed to stop 210
  - axis overshoots its target speed 211
  - axis reverses direction when stopped and started 214
  - delay upon stopping and restarting a jog

- 213
- axis scheduling** 59 – 70
  - about 60 – 62
  - alternate update period 65
  - axis assignment 64
  - configure 63
  - configure update periods 63
  - motion utilization 69
  - multiple drives 63
  - system performance 59 – 60
  - timing models 60 – 62
- axis test mode** 147
  - enable 148
  - safety simulation 152
  - simulation 150
- axis timing models**
  - one cycle timing 61
  - two cycle timing 62
- AXIS\_CIP\_DRIVE**
  - exception actions 188
  - exceptions
    - alarm 190
    - disable 190
    - fault status only 190
    - ignore 190
    - shutdown 190
    - stop planner 190

## B

- backward compatibility** 204
- backward compatibility of 100 % of time jerk calculation** 204
- base update period**
  - integrated architecture builder 41
- base update period example** 41
- basic logic for programming velocity profile and jerk rate** 205
- bus-sharing**
  - configuration 27
  - regulator 28

## C

- cabling**
  - check 122
- calculation of jerk rate** 199
  - convert % of time to engineering units 201
  - specify jerk in units/sec<sup>3</sup> 202
  - unique program considerations 202
- catalog number**
  - choose as motor data source
    - Kinetix 5700 drive 48
- check**
  - motor and feedback wiring 126
  - polarity of motor feedback 126, 127
  - receipt of marker pulse 128
- choose catalog number as motor data source**
  - Kinetix 5700 drive 48
- choose drive NV as motor data source**
  - PowerFlex 755 drive 50
- choose motor NV as motor data source**
  - Kinetix 5700 drive 50
- choose nameplate as motor data source**
  - Kinetix 5700 drive 49

## choose nonvolatile memory as motor data source

- Kinetix 5700 drive 50
- PowerFlex 755 drive 50

## CIP motion drive module

- connection
  - electronic keying mismatch 187
  - major fault 187
  - module configuration invalid 187
  - request error 187
  - service request error 187

## CIP motion simulation

- 147

## CIP Sync

- 9, 15

## commands

- motion direct 172
- motion generator 172

## commission an axis

- 119 – 145

## commission

- hookup test 119
- Motion Direct Commands 119

## communication drive

- options 11

## commutation offset

- verify 128

## commutation test

- run 128, 129

## compensation tuning parameters

- 174

## components of a motion system

- 11

## configure

- axis scheduling 63
- axis scheduling update periods 63
- exception actions 188
- torque values for tuning 177

## configure feedback-only axis properties for Kinetix drives

- using 842E-CM integrated motion encoder 87

## configure load feedback

- Kinetix 5700 drive 55

## configure master feedback

- Kinetix 5700 drive 55

## connection errors

- 186

## connection faults and errors

- 186

## ControlFLASH software

- 160

## controller types

- supported axes 11

## coordinated motion instructions

- MotionCoordinatedChangeDynamics(MCCD) 209
- MotionCoordinatedCircularMove(MCCM) 209
- MotionCoordinatedLinearMove(MCLM) 209
- MotionCoordinatedShutdown(MCSD) 209
- MotionCoordinatedShutdownReset(MCSR) 209
- MotionCoordinatedStop(MCS) 209

## current tuning configuration

- 169

## D

## data monitor

- 185

## dependent attributes

- 122

## determine

- polarity values 126, 127

## digital I/O indicators

- PowerFlex 755 drive 185

**direct commands**

- motion state 207

**direct coupled**

- linear 119
- rotary 119

**direct coupled linear load type** 120**direct coupled rotary** 120**direct coupled rotary load type** 120**disable** 189**display motor model information**

- PowerFlex 755 drive 51

**download velocity profile and jerk rate**

- program 207

**drive NV**

- choose as motor data source
- PowerFlex 755 drive 50

**drive selection** 13**drive status indicators** 186**E****easy method for programming jerk** 198**effects of velocity profiles** 199**enable axis test mode** 148**encoder marker and commutation function**

- check 122

**EtherNet/IP drives**

- available for integrated motion 12

**example motion control program**

- ladder logic 206

**examples of easy method for programming jerk**  
198**exception actions**

- configure 188

**F****faults**

- manage motion 187
- status 189

**faults and alarms** 183 - 193

- action 184
- alarms 184
- clear log 184
- condition 184
- data monitor 185
- date and time 184
- drive status indicators 183
- end state 184
- faults 184
- indicator 184
- log 183
- quick view 183, 185
- source 184
- tag monitor 183

**faults and alarms dialog box** 183

- quick view pane 185

**feedback only axis configuration example** 78**feedback polarity** 130**feedback position** 160**feedback-only axis properties for Kinetix drives**

- configure using 842E-CM integrated motion encoder 87

**feedforward tuning parameters** 174**filters tuning parameters** 175**frequency control with no feedback axis**  
**configuration example** 85, 103, 109**G****gains to tune**

- customize 46

**glossary of terms** 227**H****home offset** 160**homing** 155 - 168

- active 156
- axis 155
- examples 156
- guidelines 155
- passive 156

**homing examples**

- active 156
- passive 159

**hookup tests** 123

- adjust motor and feed back polarity 122
- check encoder marker and commutation function 122
- checking cabling 122
- establish sense of positive motor direction 122

**I****incremental feedback position** 160**inhibit axis** 191**J****jerk**

- definition 197
- easy programming 198

**jerk rate calculation** 199

- convert % of time to engineering units 201
- specify jerk in units/sec<sup>3</sup> 202
- unique program considerations 202

**K****Kinetix 350 drive**

- description 12
- minimum version of Studio 5000 Logix Designer application 12
- supported axis types 12
- voltage ranges 12

**Kinetix 5500 drive**

- axis configuration example
- velocity control with motor feedback 81
- description 12
- load observer 136
- minimum version of Studio 5000 Logix Designer application 12
- supported axis types 12
- voltage ranges 12

**Kinetix 5700 drive**

- axis configuration example

- frequency control with no feedback 85
    - catalog number
      - choose as motor data source 48
    - description 12
    - load feedback
      - configure 55
    - load observer 136
    - master feedback
      - configure 55
    - minimum version of Studio 5000 Logix Designer application 12
    - motor NV
      - choose as motor data source 50
    - nameplate
      - choose as motor data source 49
    - nonvolatile memory
      - choose as motor data source 50
    - supported axis types 12
    - voltage ranges 12
  - Kinetix 6500 drive**
    - description 13
    - load observer 136
    - minimum version of Studio 5000 Logix Designer application 13
    - supported axis types 13
    - voltage ranges 13
  - Kinetix drive**
    - axisconfigurationexampleusingControlLogix controller 87
  - Kinetix drives**
    - axis configuration example
      - feedback only 78
      - position loop with dual feedback 74
      - position loop with motor feedback only 71
    - axis configuration examples 71 - 89
- L**
- ladder diagram (LD)** 205
  - ladder logic motion control program example** 206
  - LD**
    - ladder diagram 205
  - limits tuning parameters** 176
  - linear actuator** 119, 121
  - linear actuator load type** 121
  - load dialog box** 133
  - load feedback**
    - configure for Kinetix 5700 drive 55
  - load observer** 135 - 137
    - Kinetix 5500 drive 136
    - Kinetix 5700 drive 136
    - Kinetix 6500 drive 136
  - load ratio data from motion analyzer** 141
  - load type** 119, 121
    - direct coupled linear 120
    - direct coupled rotary 120
    - linear actuator 121
    - rotary transmission 121
  - loop responses** 169
- M**
- machine home/reference** 160
  - MAFR**
    - Motion Axis Fault Reset 172
  - MAH**
    - Motion Axis Home 172
  - MAJ**
    - Motion Axis Jog 172
  - MAM**
    - Motion Axis Move 172
  - manual tune** 169 - 181
    - current tuning configuration 169
    - determine when to 169
    - loop responses 169
  - manual tuning parameters**
    - compensation parameters 174
    - feedforward parameters 174
    - filters parameters 175
    - limits parameters 176
    - planner parameters 177
    - torque parameters 177
  - manually tune an axis** 169 - 181
    - determine when to 169
  - marker homing sequence** 155
  - marker pulse**
    - check 128
  - marker test**
    - run 128
  - MAS**
    - Motion Axis Stop 172
  - master feedback for Kinetix 5700 drive**
    - configure 55
  - master speed** 217
  - MDS**
    - Motion Drive Start 172
  - MDSC**
    - lock position 217
    - program rate 218
    - program time 219
    - programming motion 217
  - monitor tags with quick watch window** 178
  - Motion Analyzer** 13
  - motion analyzer**
    - load ratio data 141
  - Motion Arm Output Cam** 208
  - Motion Arm Registration** 208
  - Motion Arm Watch Position** 208
  - motion attributes**
    - configuration attributes 157
    - motion homing configuration 159
  - Motion Axis Fault Reset** 207
  - Motion Axis Gear** 208
  - Motion Axis Home** 208
  - Motion Axis Jog** 208
  - Motion Axis Move** 173, 208
  - Motion Axis Position Cam** 208
  - motion axis shutdown** 207
  - Motion Axis Shutdown Reset** 207
  - Motion Axis Stop** 208
  - Motion Axis Time Cam** 208
  - Motion Calculate Cam Profile** 208
  - Motion Calculate Slave Values** 208
  - Motion Change Dynamics** 208

**motion configuration instructions**

- Motion Run Axis Tuning (MRAT) 209
- Motion Run Hookup Diagnostic (MRHD) 209

**motion control instructions** 205

- ladder diagram (LD) 205
- sequential function chart (SFC) 205
- structured text (SD) 205

**motion control program**

- ladder logic example 206

**motion control system**

- scaling 119

**Motion Coordinated Change Dynamics** 209**Motion Coordinated Circular Move** 209**Motion Coordinated Linear Move** 209**Motion Coordinated Shutdown** 209**Motion Coordinated Shutdown Reset** 209**Motion Coordinated Stop** 209**motion direct**

- commands
  - understanding STO bypass 144

**Motion Direct Commands**

- STO bypass 144
- STO bypass 144

**motion direct commands** 172

- availability 207 – 209
- test an axis 141

**motion direct commands for an axis or group** 142**Motion Disarm Output Cam** 208**Motion Disarm Registration** 208**Motion Disarm Watch Position** 208**Motion Drive Start** 207**motion event instructions**

- Motion Arm Output Cam (MAOC) 208
- Motion Arm Registration (MAR) 208
- Motion Arm Watch Position (MAWP) 208
- Motion Disarm Output Cam (MDOC) 208
- Motion Disarm Registration (MDR) 208
- Motion Disarm Watch Position (MDW) 208

**motion faults**

- troubleshoot 187

**motion generator** 179

- commands 172

**motion group instructions**

- Motion Group Shutdown (MGS) 208
- Motion Group Shutdown Reset (MGSR) 208
- Motion Group Stop (MGS) 208
- Motion Group Strobe Position (MGSP) 208

**Motion Group Shutdown** 208**Motion Group Shutdown Reset** 208**Motion Group Stop** 208**Motion Group Strobe Position** 208**motion instructions** 141**motion move instructions**

- Motion Axis Gear (MAG) 208
- Motion Axis Home (MAH) 208
  - active homing 156

- passive homing 156
- Motion Axis Jog (MAJ) 208
- Motion Axis Move (MAM) 208
- Motion Axis Position Cam (MAPC) 208
- Motion Axis Stop (MAS) 208
- Motion Axis Time Cam (MATC) 208
- Motion Calculate Cam Profile (MCCP) 208
- Motion Calculate Slave Values (MCSV) 208
- Motion Change Dynamics (MCD) 208
- Motion Redefine Position (MRP) 208

**motion polarity** 130**motion programming with NIMDSC** 217**Motion Redefine Position** 208**Motion Run Axis Tuning** 209**Motion Run Hookup Diagnostic** 209**motion servo** 179**motion servo off** 207**motion state instructions**

- Motion Axis Fault Reset (MAFR) 207
- Motion Axis Shutdown (MAS) 207
- Motion Axis Shutdown Reset (MASR) 207
- Motion Servo Off 207
- Motion Servo On 207

**motion status** 185**motion system**

- components 11

**motion utilization** 69**motor and feed back polarity**

- adjust 122

**motor and feedback test**

- run 126

**motor and feedback wiring**

- check 126

**motor feedback**

- check 127

**motor feedback test**

- run 127

**motor model information**

- display for PowerFlex 755 drive 51

**motor NV**

- choose as motor data source
  - Kinetix 5700 drive 50

**motor polarity** 130**motor selection** 13**MSO**

- Motion Servo Off 172
- Motion Servo On 172, 207

**N****nameplate**

- choose as motor data source
  - Kinetix 5700 drive 49

**nonvolatile memory**

- choose as motor data source
  - Kinetix 5700 drive 50
  - PowerFlex 755 drive 50

**O****one cycle timing** 61

**options**

- communication drive 11
- controller 11
- software 11

**out-of-box configuration**

- PowerFlex 527 drive 221 – 225

**P****parameter group dialog boxes** 195 – 196**parameter group dialog-box listings** 195 – 196**passive home** 155**passive homing** 156**passive homing examples** 159**percent of time**

- profile examples 198
- use to program jerk 198

**persistent media fault**

- firmware error 166

**planner tuning parameters** 177**polarity** 130

- feedback 130
- motion 130
- motor 130
- verify 128

**polarity of motor feedback**

- check 126, 127

**polarity values** 126, 127**position control with motor feedback axis**

- configuration example 114

**position feedback device** 128**position loop with dual feedback axis**

- configuration example 74

**position loop with dual motor feedback via a**

- UFB feedback device axis

- configuration example 93

**position loop with motor feedback only axis**

- configuration example 71

**position loop with motor feedback via a UFB**

- feedback device axis configuration

- example 91

**power category**

- bus
  - configuration 27
  - regulator 28

**power cycle** 159**PowerFlex 527 drive**

- axis configuration example
  - frequency control with no feedback 109
  - position control with motor feedback 114
  - velocity control with motor feedback 112
- axis configuration examples 109 – 117
- description 13
- minimum version of Studio 5000 Logix
  - Designer application 13
- out-of-box configuration 221 – 225
- supported axis types 13
- voltage ranges 13

**PowerFlex 755 drive**

- axis configuration example
  - frequency control with no feedback 103
  - position loop with dual motor feedback
    - via a UFB feedback device 93

- position loop with motor feedback via a
  - UFB feedback device 91
- torque loop with feedback 106
- velocity loop with motor feedback via a
  - UFB feedback device 97
- velocity loop with no feedback 101
- axis configuration examples 91 – 108
- description 13
- digital I/O indicators 185
- drive NV
  - choose as motor data source 50
- minimum version of Studio 5000 Logix
  - Designer application 13
- motor model information
  - display 51
- nonvolatile memory
  - choose as motor data source 50
- recommended out-of-box settings 221 – 224
- supported axis types 13
- voltage ranges 13

**profile operand**

- profile types 203
- S-curve velocity profile 204
- trapezoidal velocity profile 203

**program**

- velocity profile and jerk rate
  - profile operand 203

**program jerk**

- easy method 198
- profile examples 198

**Q****quick view pane** 185**quick watch window** 178**R****recommended out-of-box settings**

- PowerFlex 755 drive 221 – 224

**reset**

- APR fault 168

**rotary transmission** 119, 121**rotary transmission load type** 121**RSLinx® Classic** 11**RSLinx 5000 programming software**

- motion instructions 141

**run**

- commutation test 128, 129
- marker test 128
- motor and feedback test 126
- motor feedback test 127

**S****Safe Torque Off** 144**saving an ACD file versus uploading a project**

- 167

- scaling** 119
    - direct coupled linear load type 120
    - direct coupled rotary load type 120
    - linear actuator load type 121
    - motion control system 119
    - online 167
    - rotary transmission load type 121
    - signature 164
  - scaling factors**
    - effects of changing 121
  - scaling parameters**
    - generation of APR fault 167
  - S-curve profile** 198
  - SD**
    - structured text 205
  - selecting drives** 13
  - selecting motors** 13
  - sense of positive motor direction**
    - establish 122
  - sequential function chart (SFC)** 205
  - SERCOS versus integrated motion on Ethernet networks** 161
  - SFC**
    - sequential function chart 205
  - single-axis** 12
  - slave speed** 217
  - software**
    - options 11
  - STO**
    - bypass 144
  - structured text (SD)** 205
  - supported axes** 11
- T**
- test an axis with motion direct commands** 141
  - timing models** 60 – 62
  - torque loop with feedback axis configuration example** 106
  - torque tuning parameters** 177
  - torque values**
    - configure for tuning 177
  - trapezoidal** 155
  - trapezoidal profile** 197
  - troubleshoot**
    - motion faults 187
  - troubleshoot axis motion** 209 – 216
    - axis accelerates when instructed to stop 210
    - axis delay upon stopping and restarting a jog 213
    - axis overshoots its target speed 211
    - axis reverses direction when stopped and started 214
  - troubleshoot faults**
    - instruction error 187
  - tune**
    - compensation 174
    - feedforward 174
    - filters 175
    - limits 176
    - manual 169
    - planner 177
  - tune an axis manually** 169 – 181
    - determine when to 169
  - tuning parameters**
    - compensation 174
    - feedforward 174
    - filters 175
    - limits 176
    - planner 177
    - torque 177
  - two cycle timing** 62
- U**
- understanding STO bypass when using motion direct commands** 144
  - update periods**
    - configure 63
- V**
- velocity and jerk rate**
    - S-curve profile 198
    - trapezoidal profile 197
  - velocity control with motor feedback axis configuration example** 81, 112
  - velocity loop with motor feedback via a UFB feedback device axis configuration example** 97
  - velocity loop with no feedback axis configuration example** 101
  - velocity profile and jerk rate**
    - choose a profile 197
    - download program 207
    - enter basic logic 205
    - ladder logic motion control program example 206
    - profile operand 203
      - S-curve velocity profile 204
      - trapezoidal velocity profile 203
  - velocity profile comparison** 199
  - velocity profile effects** 199

**Notes:**



# Rockwell Automation Support

Use these resources to access support information.

<b>Technical Support Center</b>	Find help with how-to videos, FAQs, chat, user forums, Knowledgebase, and product notification updates.	<a href="http://rok.auto/support">rok.auto/support</a>
<b>Local Technical Support Phone Numbers</b>	Locate the telephone number for your country.	<a href="http://rok.auto/phonesupport">rok.auto/phonesupport</a>
<b>Technical Documentation Center</b>	Quickly access and download technical specifications, installation instructions, and user manuals.	<a href="http://rok.auto/techdocs">rok.auto/techdocs</a>
<b>Literature Library</b>	Find installation instructions, manuals, brochures, and technical data publications.	<a href="http://rok.auto/literature">rok.auto/literature</a>
<b>Product Compatibility and Download Center (PCDC)</b>	Download firmware, associated files (such as AOP, EDS, and DTM), and access product release notes.	<a href="http://rok.auto/pcdc">rok.auto/pcdc</a>

## Documentation Feedback

Your comments help us serve your documentation needs better. If you have any suggestions on how to improve our content, complete the form at [rok.auto/docfeedback](http://rok.auto/docfeedback).

## Waste Electrical and Electronic Equipment (WEEE)



At the end of life, this equipment should be collected separately from any unsorted municipal waste.

Rockwell Automation maintains current product environmental compliance information on its website at [rok.auto/pec](http://rok.auto/pec).

Allen-Bradley, Armor, ArmorKinetix, CompactLogix, ControlFLASH, ControlLogix, DriveExecutive, DriveExplorer, DriveTools, expanding human possibility, FactoryTalk, GuardLogix, Integrated Architecture, iTRAK, Kinetix, Logix 5000, On-Machine, PowerFlex, QuickView, Rockwell Automation, Rockwell Software, RSLinx, RSLogix 5000, Stratix, Studio 5000, and Studio 5000 Logix Designer are trademarks of Rockwell Automation, Inc.

CIP, CIP Safety, CIP Sync, and EtherNet/IP are trademarks of ODVA, Inc.

Trademarks not belonging to Rockwell Automation are property of their respective companies.

Rockwell Otomasyon Ticaret A.Ş. Kar Plaza İş Merkezi E Blok Kat:6 34752, İçerenköy, İstanbul, Tel: +90 (216) 5698400 EEE Yönetmeliğine Uygundur

Connect with us.    

**rockwellautomation.com** ————— **expanding human possibility®**

AMERICAS: Rockwell Automation, 1201 South Second Street, Milwaukee, WI 53204-2496 USA, Tel: (1) 414.382.2000

EUROPE/MIDDLE EAST/AFRICA: Rockwell Automation NV, Pegasus Park, De Kleetlaan 12a, 1831 Diegem, Belgium, Tel: (32) 2663 0600

ASIA PACIFIC: Rockwell Automation SEA Pte Ltd, 2 Corporation Road, #04-05, Main Lobby, Corporation Place, Singapore 618494, Tel: (65) 6510 6608

UNITED KINGDOM: Rockwell Automation Ltd., Pitfield, Kiln Farm, Milton Keynes, MK11 3DR, United Kingdom, Tel: (44)(1908) 838-800

Publication MOTION-UM003P-EN-P - January 2025

Supersedes Publication MOTION-UM0030-EN-P - May 2024

Copyright © 2025 Rockwell Automation, Inc. All rights reserved. Printed in the U.S.A.