

BNI IOL-311-002-K006
BNI IOL-311-S02-K006-C01
IO-Link 1.1 NPN Sensor/Actuator Hub
with extension port
User's Guide





Contents

1	User Instructions	5
1.1.	About this Manual	5
1.2.	Structure of the Manual	5
1.3.	Typographical Conventions	5
	Enumerations	5
	Actions	5
	Syntax	5
	Cross references	5
1.4.	Symbols	5
1.5.	Abbreviations	5
1.6.	Differing views	5
2	Safety	6
2.1.	Intended Use	6
2.2.	Installation and Startup	6
2.3.	General Safety Instructions	6
2.4.	Resistance to aggressive substances	6
	Hazardous voltage	6
3	First Steps	7
3.1.	Connection overview	7
3.2.	Mechanical Connection	8
3.3.	Electrical Connection	8
	Function ground	8
	IO-Link connection	8
	Connecting the sensor hub	9
	Module variants	9
	Digital sensors	9
	Extension port	9
	Extension port	10
	Extension port configuration	10
4	Configuration: BNI IOL-311-002-K006	11
4.1.	IO-Link Data	11
4.2.	Process Data/ Input Data	11
4.3.	Process Data/ Output Data	11
4.4.	Parameter Data/ Demand Data	12
	Device Access Locks 0Chex	13
	Inversion of the inputs 40hex	13
	Configuration of inputs /outputs 41hex	13
	Safe state of the outputs 42hex	14
	Safe state of the outputs on Pin 4 42hex	14
	Safe state of the outputs on Pin 2 43hex	14
	Voltage monitoring 44hex	15
	Output monitoring 45hex	15
	Actuator warning 46hex	15
	Setting the serial number 54hex	16
	Configuration of the extension port 55hex	16
5	Configuration: BNI IOL-311-002-K006 extended with BNI IOL-311-002-K006	17
5.1.	IO-Link Data	17
5.2.	Process Data/ Input Data	17
5.3.	Process Data/ Output Data	18
5.4.	Parameter Data/ Demand Data	19
	Device Access Locks 0Chex	20
	Inversion of the inputs 40hex	20
	Configuration of inputs/ outputs 41hex	21
	Safe state of the outputs 42hex	22
	Safe state of the outputs on Pin 4 42hex	22

Safe state of the outputs on Pin 2 43hex	23
Voltage monitoring 44hex	24
Output monitoring 45hex	24
Actuator warning 46hex	25
Setting the serial number 54hex	26
Configuration of the extension port 55hex	26
6 Configuration: BNI IOL-311-002-K006 extended with valve terminal connector with 22/24 valves	27
6.1. IO-Link Data	27
6.2. Process Data/ Input Data	27
6.3. Process Data/ Output Data	27
6.4. Parameter Data / Demand Data	29
Device Access Locks 0Chex	30
Inversion of the inputs 40hex	30
Configuration of inputs/ outputs 41hex	30
Safe state of the outputs 42hex	31
Safe state of the outputs on Pin 4 42hex	31
Safe state of the outputs on Pin 2 43hex	32
Voltage monitoring 44hex	33
Output monitoring 45hex	34
Actuator warning 46hex	35
Setting the serial number 54hex	35
Configuration of the extension port 55hex	35
7 Configuration: BNI IOL-311-S02-K006-C01	36
7.1. IO-Link Data	36
7.2. Process Data/ Input Data	36
7.3. Process Data/ Output Data	37
7.4. Parameter Data/ Demand Data	38
Device Access Locks 0Chex	39
Inversion of the inputs 40hex	39
Configuration of inputs /outputs 41hex	39
Safe state of the outputs 42hex	40
Safe state of the outputs on Pin 4 42hex	40
Safe state of the outputs on Pin 2 43hex	40
Voltage monitoring 44hex	41
Output monitoring 45hex	41
Actuator warning 46hex	41
Setting the serial number 54hex	42
Configuration of the extension port 55hex	42
Identification 60hex	42
8 Configuration: BNI IOL-311-S02-K006-C01 extended with BNI IOL-311-S02-K006-C01	43
8.1. IO-Link Data	43
8.2. Process Data/ Input Data	43
8.3. Process Data / Output Data	46
8.4. Parameter Data/ Demand Data	47
Parameter Data/ Demand Data	47
Device Access Locks 0Chex	48
Inversion of the inputs 40hex	48
Configuration of inputs/ outputs 41hex	49
Safe state of the outputs 42hex	50
Safe state of the outputs on Pin 4 42hex	50
Safe state of the outputs on Pin 2 43hex	51
Voltage monitoring 44hex	52
Output monitoring 45hex	52
Actuator warning 46hex	53
Setting the serial number 54hex	54
Configuration of the extension port 55hex	54
Identification 60hex	54
9 Configuration: BNI IOL-311-S02-K006-C01 extended with Valve Terminal Connector with 22/24 Valves	55
9.1. IO-Link Data	55
9.2. Process Data/ Input Data	55
9.3. Process Data / Output Data	56
9.4. Parameter Data / Demand Data	58

Device Access Locks 0Chex	59
Inversion of the inputs 40hex	59
Configuration of inputs/ outputs 41hex	59
Safe state of the outputs 42hex	60
Safe state of the outputs Pin 4 42hex	60
Safe state of the outputs on Pin 2 43hex	61
Voltage monitoring 44hex	62
Output monitoring 45hex	63
Actuator warning 46hex	64
Setting the serial number 54hex	64
Configuration of the extension port 55hex	64
Identification 60hex	64
10 Error Codes and Events	65
10.1. Error Codes/ Errors	65
10.2. Events	65
11 IO-Link Functions	66
11.1. IO-Link Version 1.0/ 1.1	66
11.2. Data Storage	66
11.3. Block Configuration	66
11.4. Restoring the Factory Settings	66
12 Technical Data	67
12.1. Dimensions	67
12.2. Mechanical Data	67
12.3. Electrical Data	67
12.4. Operating conditions	67
13 Function Indicators	68
13.1. Function Indicators	68
LED indicator module status	68
Digital LED indicators for inputs/outputs	69
Extension port	69
14 Appendix	70
14.1. Type Code	70
14.2. Ordering Information	70
Notes	71

1 User Instructions

- 1.1. About this Manual** This manual describes the Balluff IO-Link I/O module, also called a sensor/actuator hub. The IO-Link protocol is used to link to the higher-level master module. In terms of function, this compact, cost-effective module is similar to a passive splitter box; it records digital sensor signals and transmits them over the IO-Link interface. It passes control signals coming over IO-Link to the connected actuators.
- 1.2. Structure of the Manual** The manual is organized so that the sections build on one another.
Chapter 2: Basic safety information.
.....
- 1.3. Typographical Conventions** The following typographical conventions are used in this manual.
- Enumerations** Enumerations are shown as a list with an en-dash.
- Entry 1.
 - Entry 2.
- Actions** Action instructions are indicated by a preceding triangle. The result of an action is indicated by an arrow.
- Action instruction 1.
 - ↔ Action result.
 - Action instruction 2.
- Syntax** **Numbers:**
Decimal numbers are shown without additional indicators (e.g. 123), hexadecimal numbers are shown with the additional indicator _{hex} (e. g. 00_{hex}).
- Cross references** Cross references indicate where additional information on the topic can be found.
-
- 1.4. Symbols**
-  **Attention!**
This symbol indicates a safety instruction that must be followed without exception.
-
-  **Note**
This symbol indicates general notes.
-
- 1.5. Abbreviations**
- | | |
|----------|-------------------------------|
| BNI | Balluff Network Interface |
| DPP | Direct Parameter Page |
| I/O port | Digital input/output port |
| IOL | IO-Link |
| EMC | Electromagnetic compatibility |
| FE | Function ground |
| LSB | Least Significant Bit |
| MSB | Most Significant Bit |
| SPDU | Service Protocol Data Unit |
| GND | Ground |
| US | Sensor supply |
| UA | Actuator supply |
- 1.6. Differing views** Product views and images in this manual may differ from the product described. They are intended to serve only as illustrations.

2 Safety

2.1. Intended Use

The BNI IOL-... acts as a decentralized input/output sensor module, which is connected to a higher-level IO-Link master module through an IO-Link interface.

2.2. Installation and Startup



Attention

Installation and startup must only be carried out by trained technical personnel. Qualified personnel are people who are familiar with installation and operation of the product and have the necessary qualifications for these tasks. Any damage resulting from unauthorized tampering or improper use voids the manufacturer's guarantee and warranty. The operator must ensure that appropriate safety and accident prevention regulations are observed.

2.3. General Safety Instructions

Commissioning and inspection

Before commissioning, carefully read the user's guide.

The system must not be used in applications in which the safety of persons is dependent upon proper functioning of the device.

Authorized personnel

Installation and startup must only be carried out by trained technical personnel.

Intended use

Warranty and liability claims against the manufacturer are rendered void by:

- Unauthorized tampering
- Improper use
- Use, installation or handling contrary to the instructions provided in this user's m

Obligations of the operating company

The device is a piece of equipment in accordance with EMC Class A. This device can produce RF noise. The operator must take appropriate precautionary measures. The device may only be used with an approved power supply. Only use approved cables.

Malfunctions

In the event of defects and device malfunctions that cannot be rectified, the device must be taken out of operation and protected against unauthorized use.

Intended use is ensured only when the housing is fully installed.

2.4. Resistance to aggressive substances



Attention

The BNI modules generally have a good chemical and oil resistance. When used in aggressive media (eg chemicals, oils, lubricants and coolants each in high concentration (ie, low water content)) must be checked prior application-related material compatibility. In the event of failure or damage to the BNI modules due to such aggressive media are no claims for defects.

Hazardous voltage



Attention

Before maintenance, disconnect the device from the power supply.



Note

In the interests of product improvement, Balluff GmbH reserves the right to change the technical data of the product and the content of this manual at any time without notice.

3 First Steps

3.1. Connection overview

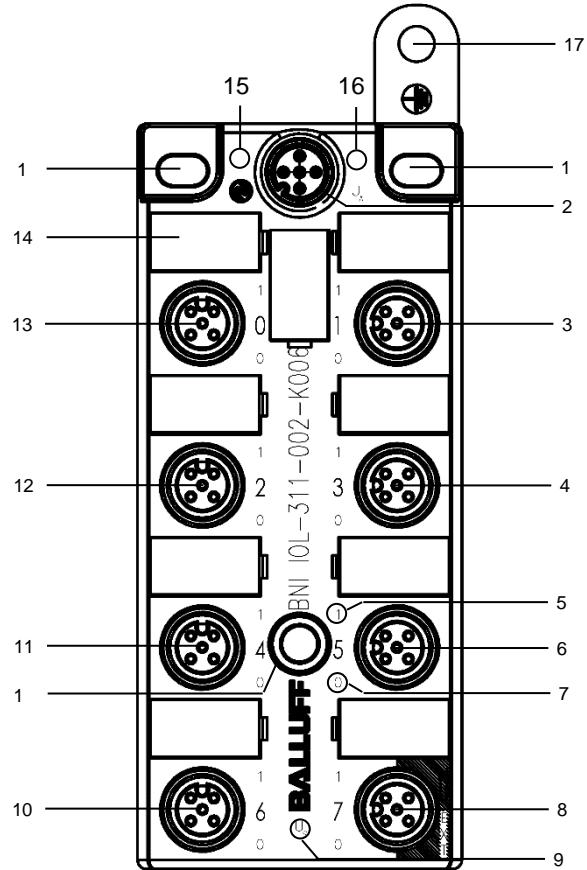

Figure 3-1: Connection overview BNI IOL-311-x02-K006

- | | |
|---|--|
| 1 Mounting hole | 9 Status LED: Power supply for sensors |
| 2 IO-Link interface | 10 Standard I/O port 6 |
| 3 Standard I/O port 1 | 11 Standard I/O port 4 |
| 4 Standard I/O port 3 | 12 Standard I/O port 2 |
| 5 Status LED: Standard I/O port 5 (pin 2) | 13 Standard I/O port 0 |
| 6 Standard I/O port 5 | 14 Label |
| 7 Status LED: Standard I/O port 5 (pin 4) | 15 Status LED IO-Link |
| 8 Extension port or standard I/O port 7 | 16 Status LED power supply for actuators |
| | 17 Ground connection |

3 First Steps

3.2. Mechanical Connection

The BNI IOL modules are fastened with 3 M4 screws.

3.3. Electrical Connection

The BNI IOL-311-x02-K006 modules do not require a separate supply voltage connection. Supply voltage is provided via the IO-Link interface and the higher-level IO-Link master module.

Function ground

The modules are equipped with a ground connection.

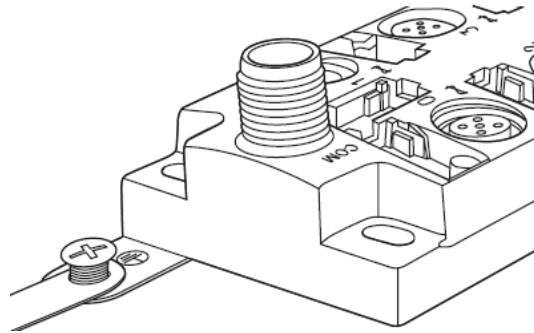

Figure 3-3: BNI ground connection IOL-311...

- Connect the sensor hub module to the ground connection.



Note

The FE connection from the housing to the machine must have low-impedance and be kept as short as possible.

IO-Link connection

The IO-Link connection is established via an M12 connector (A-coded, male).

IO-Link (M12, A-coded, male)

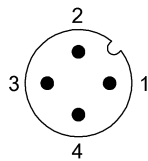

Pin	Requirement
1	Supply voltage for controller US, +24 V
2	Supply voltage for actuators UA, +24 V
3	GND, reference potential
4	C/Q, IO-Link data transmission channel

3 First Steps

Connecting the sensor hub

- Connect ground conductor to the FE terminal, if available.
- Connect the incoming IO-Link cable to the sensor hub.



Note

A standardized sensor cable is used to connect to the higher-level IO-Link master module. Maximum length of 20 m.

Module variants

Sensor hub variants	Digital port
BNI IOL-311-002-K006	16 NPN inputs / NPN outputs, freely configurable
BNI IOL-311-S02-K006-C01	16 NPN inputs / NPN outputs, freely configurable with single channel monitoring and identification

Digital sensors

Digital NPN input / NPN output port (M12, A-coded, female)

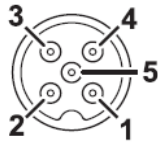

Pin	Requirement
1	+24 V
2	NPN Input 2 / NPN output 2
3	0 V, GND
4	NPN Input 1 / NPN output 1
5	FE



Note

For the digital inputs, the input guideline specified in EN 61131-2, Type 3 applies.



Note

Unused input port sockets must be fitted with blind caps to ensure the IP67 protection rating.

Extension port

Digital input/output port (M12, A-coded, female)

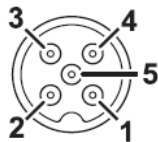

Pin	Requirement
1	+24 V
2	Extension port for actuator power supply
3	0 V, GND
4	Communication
5	FE



Note

A standardized sensor cable is used to connect to the device to be extended. Maximum length of 20 m.

3 First Steps

Extension port

The BNI IOL-311-002-K006 and BNI IOL-311-S02-K006-C01 NPN modules give you the ability to use the No. 7 slot in various ways. By default, it is used as a digital I/O slot, where both pin 2 and pin 4 can be used as a digital input or output.

This slot can be used as an Extension port by making a corresponding entry in the parameter with an index of 55hex. This makes it possible to operate one of the following modules using the No. 7 slot.

- BNI IOL-311-002-K006 or BNI IOL-311-S02-K006-C01
- BNI IOL-751-V08-K007
- BNI IOL-751-V10-K007
- BNI IOL-751-V13-K007



Extension port configuration

Configuration	Index 55hex value
BNI IOL-311-002-K006 / BNI IOL-311-S02-K006-C01	0
BNI IOL-311-002-K006 with BNI IOL-311-002-K006 / BNI IOL-311-S02-K006-C01 with BNI IOL-311-S02-K006-C01	1
BNI IOL-311-002-K006 with BNI IOL-751-V08-K007/ BNI IOL-311-S02-K006-C01 with BNI IOL-751-V08-K007	2
BNI IOL-311-002-K006 with BNI IOL-751-V10-K007/ BNI IOL-311-S02-K006-C01 with BNI IOL-751-V10-K007	3
BNI IOL-311-002-K006 with BNI IOL-751-V13-K007/ BNI IOL-311-S02-K006-C01 with BNI IOL-751-V13-K007	4



Note

The "Factory reset" command does not affect the configuration of the extension port in any way.



Note

The process data length depends on the configuration.

The configuration of the extension port can be performed via the parameter 0x55 (table). If the data storage or the validation is used, must be configured on the validation (identical). Depending on the system, the device ID has to be entered (table parameter data) or the device ID is read out from the IODD.

4 Configuration: BNI IOL-311-002-K006



4.1. IO-Link Data

BNI IOL-311-002-K006	
Transfer rate	COM2 (38.4 kbaud)
Minimum cycle time	3.5 ms
Process data length	2 byte input, 2 byte output

4.2. Process Data/
Input Data

BNI IOL-311-002-K006
Process data length of 2 bytes:

Byte	0								1							
Bit	7	6	5	4	3	2	1	0	7	6	5	4	3	2	1	0
Description	Input Port 7 Pin 4	Input Port 6 Pin 4	Input Port 5 Pin 4	Input Port 4 Pin 4	Input Port 3 Pin 4	Input Port 2 Pin 4	Input Port 1 Pin 4	Input Port 0 Pin 4	Input Port 7 Pin 2	Input Port 6 Pin 2	Input Port 5 Pin 2	Input Port 4 Pin 2	Input Port 3 Pin 2	Input Port 2 Pin 2	Input Port 1 Pin 2	Input Port 0 Pin 2

4.3. Process Data/
Output Data

BNI IOL-311-002-K006
Process data length of 2 bytes:

Byte	0								1							
Bit	7	6	5	4	3	2	1	0	7	6	5	4	3	2	1	0
Description	Output Port 7 Pin 4	Output Port 6 Pin 4	Output Port 5 Pin 4	Output Port 4 Pin 4	Output Port 3 Pin 4	Output Port 2 Pin 4	Output Port 1 Pin 4	Output Port 0 Pin 4	Output Port 7 Pin 2	Output Port 6 Pin 2	Output Port 5 Pin 2	Output Port 4 Pin 2	Output Port 3 Pin 2	Output Port 2 Pin 2	Output Port 1 Pin 2	Output Port 0 Pin 2

4 Configuration: BNI IOL-311-002-K006

4.4. Parameter Data/
Demand Data

	DPP	SPDU		Parameter	Data width	Access rights	Default value
	Index	Index	Sub-index				
Identification data	07hex			Vendor ID	2 bytes	Read only	0378hex
	08hex						
	09hex			Device ID	3 bytes		0x05 0B C0
	0Ahex						
	0Bhex						
		0Chex 12	0	Device Access Locks	2 bytes	Read/write	0hex
		10hex 16	0	Vendor name	7 bytes	Read only	BALLUFF
		11hex 17	0	Vendor text	15 bytes		www.balluff.com
		12hex 18	0	Product name			BNI IOL-311-002-K006
		13hex 19	0	Product ID	7 bytes		BNI00AF
		14hex 20	0	Product text			Sensor/Actor NPN Hub M12
		15hex 21	0	Serial number	16 bytes		0hex
		16hex 22	0	Hardware Revision			
		17hex 23	0	Firmware Revision			
	18hex 24	0	Application Specific Tag	32 bytes	Read / Write	0hex	

	DPP	SPDU		Parameter	Data width	Access rights	Default Value
	Index	Index	Subindex				
Parameter data		40hex 64	0 1-16	Inversion of the inputs	2 bytes	Read / Write	0hex
		41hex 65	0 1-8	Config. inputs/outputs	1 byte	Read / Write	0hex
		42hex 66	0 1-8	Pin 4 safe state	2 bytes	Read / Write	0hex
		43hex 67	0 1-8	Pin 2 safe state	2 bytes	Read / Write	0hex
		44hex 68	0 1-16	Voltage monitoring	2 bytes	Read	-
		45hex 69	0 1-16	Output monitoring	2 bytes	Read	-
		46hex 70	0 1-16	Actuator warning	2 bytes	Read	-
		54hex 84	0	Serial number	16 bytes	Read / Write	16x00hex
		55hex 85	0	Extension port	1 byte	Read / Write	0hex

4 Configuration: BNI IOL-311-002-K006

Device Access Locks 0C_{hex} The parameter Device Access Locks allows control of the Device behavior. Only Data Storage standardized device functions can be configured via the defined flag in this parameter. The Device Access Locks configuration can be changed by overwriting the parameter. The actual configuration setting is available per read access to this parameter. Access is only permitted via Subindex 0.

Inversion of the inputs 40_{hex}

Byte	0								1							
Bit	7	6	5	4	3	2	1	0	7	6	5	4	3	2	1	0
Sub-index	8	7	6	5	4	3	2	1	16	15	14	13	12	11	10	9
Description	Inversion Port 7 Pin 4	Inversion Port 6 Pin 4	Inversion Port 5 Pin 4	Inversion Port 4 Pin 4	Inversion Port 3 Pin 4	Inversion Port 2 Pin 4	Inversion Port 1 Pin 4	Inversion Port 0 Pin 4	Inversion Port 7 Pin 2	Inversion Port 6 Pin 2	Inversion Port 5 Pin 2	Inversion Port 4 Pin 2	Inversion Port 3 Pin 2	Inversion Port 2 Pin 2	Inversion Port 1 Pin 2	Inversion Port 0 Pin 2

Inversion of port (x):

- 0 – Normal
- 1 - Inverted

Configuration of inputs /outputs 41_{hex}

Byte	0							
Bit	7	6	5	4	3	2	1	0
Sub-index	8	7	6	5	4	3	2	1
Description	Direction Port 7	Direction Port 6	Direction Port 5	Direction Port 4	Direction Port 3	Direction Port 2	Direction Port 1	Direction Port 0

Direction of port (x):

- 0 – Input
- 1 – Output

4 Configuration: BNI IOL-311-002-K006

Safe state of the outputs
42hex

The safe state parameter makes it possible to configure the outputs in case of a fault. If no IO-Link communication is possible or the "valid flag" of the output process data has not been set by the master, then each output adopts the configured status. The following statuses can be configured for each pin.

Safe state of the outputs on Pin 4 42hex

Byte	0								1							
Bit	7	6	5	4	3	2	1	0	7	6	5	4	3	2	1	0
Sub-index	4		3		2		1		8		7		6		5	
Description	Safe state Port 3 Pin 4		Safe state Port 2 Pin 4		Safe state Port 1 Pin 4		Safe state Port 0 Pin 4		Safe state Port 7 Pin 4		Safe state Port 6 Pin 4		Safe state Port 5 Pin 4		Safe state Port 4 Pin 4	

Safe state of the outputs on Pin 2 43hex

Byte	0								1							
Bit	7	6	5	4	3	2	1	0	7	6	5	4	3	2	1	0
Sub-index	4		3		2		1		8		7		6		5	
Description	Safe state Port 3 Pin 2		Safe state Port 2 Pin 2		Safe state Port 1 Pin 2		Safe state Port 0 Pin 2		Safe state Port 7 Pin 2		Safe state Port 6 Pin 2		Safe state Port 5 Pin 2		Safe state Port 4 Pin 2	

Value		Output state
bin	dec	
00	0	Output is 0V
01	1	Output is 24V
10	2	Current status is maintained
11	3	Not defined

4 Configuration: BNI IOL-311-002-K006

Voltage monitoring
44hex

Byte	0								1							
Bit	7	6	5	4	3	2	1	0	7	6	5	4	3	2	1	0
Sub-index	8	7	6	5	4	3	2	1					12	11		9
Description	Short-circuit Port 7 Pin 1	Short-circuit Port 6 Pin 1	Short-circuit Port 5 Pin 1	Short-circuit Port 4 Pin 1	Short-circuit Port 3 Pin 1	Short-circuit Port 2 Pin 1	Short-circuit Port 1 Pin 1	Short-circuit Port 0 Pin 1	-	-	-	-	Outputs off (UA too low)	Undervoltage UA	-	Undervoltage US

Output monitoring
45hex

Byte	0								1							
Bit	7	6	5	4	3	2	1	0	7	6	5	4	3	2	1	0
Sub-index	8	7	6	5	4	3	2	1	16	15	14	13	12	11	10	9
Description	Short-circuit Port 7 Pin 4	Short-circuit Port 6 Pin 4	Short-circuit Port 5 Pin 4	Short-circuit Port 4 Pin 4	Short-circuit Port 3 Pin 4	Short-circuit Port 2 Pin 4	Short-circuit Port 1 Pin 4	Short-circuit Port 0 Pin 4	Short-circuit Port 7 Pin 2	Short-circuit Port 6 Pin 2	Short-circuit Port 5 Pin 2	Short-circuit Port 4 Pin 2	Short-circuit Port 3 Pin 2	Short-circuit Port 2 Pin 2	Short-circuit Port 1 Pin 2	Short-circuit Port 0 Pin 2

Actuator warning 46hex

Byte	0								1							
Bit	7	6	5	4	3	2	1	0	7	6	5	4	3	2	1	0
Sub-index	8	7	6	5	4	3	2	1	16	15	14	13	12	11	10	9
Description	Warning Port 7 Pin 4	Warning Port 6 Pin 4	Warning Port 5 Pin 4	Warning Port 4 Pin 4	Warning Port 3 Pin 4	Warning Port 2 Pin 4	Warning Port 1 Pin 4	Warning Port 0 Pin 4	Warning Port 7 Pin 2	Warning Port 6 Pin 2	Warning Port 5 Pin 2	Warning Port 4 Pin 2	Warning Port 3 Pin 2	Warning Port 2 Pin 2	Warning Port 1 Pin 2	Warning Port 0 Pin 2

4 Configuration: BNI IOL-311-002-K006

Setting the serial number 54_{hex}

The serial number has a default value of 16x00_{hex}.
In order to use the "Identity" master validation mode, a serial number can be set using this parameter.
This prevents a device from connecting to the wrong master port.

Configuration of the extension port 55_{hex}

Configuration	Index 55 _{hex} value
BNI IOL-311-002-K006	0
BNI IOL-311-002-K006 with BNI IOL-311-002-K006	1
BNI IOL-311-002-K006 with BNI IOL-751-V08-K007	2
BNI IOL-311-002-K006 with BNI IOL-751-V10-K007	3
BNI IOL-311-002-K006 with BNI IOL-751-V13-K007	4



Note

The "Factory reset" command does not affect the configuration of the extension port in any way.

5 Configuration: BNI IOL-311-002-K006 extended with BNI IOL-311-002-K006



5.1. IO-Link Data

BNI IOL-311-002-K006 extended with BNI IOL-311-002-K006	
Transfer rate	COM2 (38.4 kbaud)
Minimum cycle time	4.5 ms
Process data length	4 byte input, 4 byte output

5.2. Process Data/
Input Data

Process data length of 4 bytes:

Byte	0								1							
	7	6	5	4	3	2	1	0	7	6	5	4	3	2	1	0
Description	-	Input Port 6 pin 4	Input Port 5 pin 4	Input Port 4 pin 4	Input Port 3 pin 4	Input Port 2 pin 4	Input Port 1 pin 4	Input Port 0 pin 4	-	Input Port 6 pin 2	Input Port 5 pin 2	Input Port 4 pin 2	Input Port 3 pin 2	Input Port 2 pin 2	Input Port 1 pin 2	Input Port 0 pin 2

Byte	2								3							
	7	6	5	4	3	2	1	0	7	6	5	4	3	2	1	0
Extension port																
Description	Input Port 7 pin 4	Input Port 6 pin 4	Input Port 5 pin 4	Input Port 4 pin 4	Input Port 3 pin 4	Input Port 2 pin 4	Input Port 1 pin 4	Input Port 0 pin 4	Input Port 7 pin 2	Input Port 6 pin 2	Input Port 5 pin 2	Input Port 4 pin 2	Input Port 3 pin 2	Input Port 2 pin 2	Input Port 1 pin 2	Input Port 0 pin 2

5 Configuration: BNI IOL-311-002-K006 extended with BNI IOL-311-002-K006

5.3. Process Data/
Output Data

Process data length of 4 bytes:

Byte	0								1							
Bit	7	6	5	4	3	2	1	0	7	6	5	4	3	2	1	0
Description	-	Output Port 6 Pin 4	Output Port 5 Pin 4	Output Port 4 Pin 4	Output Port 3 Pin 4	Output Port 2 Pin 4	Output Port 1 Pin 4	Output Port 0 Pin 4	-	Output Port 6 Pin 2	Output Port 5 Pin 2	Output Port 4 Pin 2	Output Port 3 Pin 2	Output Port 2 Pin 2	Output Port 1 Pin 2	Output Port 0 Pin 2

Byte	2								3							
Bit	7	6	5	4	3	2	1	0	7	6	5	4	3	2	1	0
	Extension port															
Description	Output Port 7 Pin 4	Output Port 6 Pin 4	Output Port 5 Pin 4	Output Port 4 Pin 4	Output Port 3 Pin 4	Output Port 2 Pin 4	Output Port 1 Pin 4	Output Port 0 Pin 4	Output Port 7 Pin 2	Output Port 6 Pin 2	Output Port 5 Pin 2	Output Port 4 Pin 2	Output Port 3 Pin 2	Output Port 2 Pin 2	Output Port 1 Pin 2	Output Port 0 Pin 2

5 Configuration: BNI IOL-311-002-K006 extended with BNI IOL-311-002-K006

5.4. Parameter Data/
Demand Data

	DPP	SPDU		Parameter	Data width	Access rights	Default value
	Index	Index	Sub-index				
Identification data	07hex			Vendor ID	2 bytes	Read only	0378hex
	08hex						
	09hex			Device ID	3 bytes		0x05 0B C1
	0Ahex						
	0Bhex						
		0Chex 12	0	Device Access Locks	2 bytes	Read/write	0hex
		10hex 16	0	Vendor Name	7 bytes	Read only	BALLUFF
		11hex 17	0	Vendor text	15 bytes		www.balluff.com
		12hex 18	0	Product Name			BNI IOL-311-002-K006 with BNI IOL-311-002-K006
		13hex 19	0	Product ID	7 bytes		BNI00AF with BNI00AF
		14hex 20	0	Product text			Sensor/Actor NPN Hub M12 with Sensor/Actor NPN Hub M12
		15hex 21	0	Serial number	16 bytes		0hex
		16hex 22	0	Hardware Revision			
		17hex 23	0	Firmware Revision			
	18hex 24	0	Application Specific Tag	32 bytes	Read / Write	0hex	

	DPP	SPDU		Parameter	Data width	Access rights	Default Value
	Index	Index	Subindex				
Parameter data		40hex 64	0 1-32	Inversion of the inputs	4 bytes	Read / Write	0hex
		41hex 65	0 1-16	Config. inputs/outputs	2 bytes	Read / Write	0hex
		42hex 66	0 1-16	Safe state Pin 4	4 bytes	Read / Write	0hex
		43hex 67	0 1-16	Safe state Pin 2	4 bytes	Read / Write	0hex
		44hex 68	0 1-32	Voltage monitoring	4 bytes	Read	-
		45hex 69	0 1-32	Output monitoring	4 bytes	Read	-
		46hex 70	0 1-32	Actuator warning	4 bytes	Read	-
		54hex 84	0	Serial number	16 bytes	Read / Write	16x00hex
		55hex 85	0	Extension port	1 byte	Read / Write	1hex

5 Configuration: BNI IOL-311-002-K006 extended with BNI IOL-311-002-K006

Device Access Locks 0Chex

The parameter Device Access Locks allows control of the Device behavior. Only Data Storage standardized device functions can be configured via the defined flag in this parameter. The Device Access Locks configuration can be changed by overwriting the parameter. The actual configuration setting is available per read access to this parameter. Access is only permitted via Subindex 0.

Inversion of the inputs 40hex

Byte	0								1							
Bit	7	6	5	4	3	2	1	0	7	6	5	4	3	2	1	0
Sub-index	8	7	6	5	4	3	2	1	16	15	14	13	12	11	10	9
Description	* Inversion Port 7 Pin 4	Inversion Port 6 Pin 4	Inversion Port 5 Pin 4	Inversion Port 4 Pin 4	Inversion Port 3 Pin 4	Inversion Port 2 Pin 4	Inversion Port 1 Pin 4	Inversion Port 0 Pin 4	* Inversion Port 7 Pin 2	Inversion Port 6 Pin 2	Inversion Port 5 Pin 2	Inversion Port 4 Pin 2	Inversion Port 3 Pin 2	Inversion Port 2 Pin 2	Inversion Port 1 Pin 2	Inversion Port 0 Pin 2

* No function

Byte	2								3							
Bit	7	6	5	4	3	2	1	0	7	6	5	4	3	2	1	0
Sub-index	24	23	22	21	20	19	18	17	32	31	30	29	28	27	26	25
	Extension port															
Description	Inversion Port 7 Pin 4	Inversion Port 6 Pin 4	Inversion Port 5 Pin 4	Inversion Port 4 Pin 4	Inversion Port 3 Pin 4	Inversion Port 2 Pin 4	Inversion Port 1 Pin 4	Inversion Port 0 Pin 4	Inversion Port 7 Pin 2	Inversion Port 6 Pin 2	Inversion Port 5 Pin 2	Inversion Port 4 Pin 2	Inversion Port 3 Pin 2	Inversion Port 2 Pin 2	Inversion Port 1 Pin 2	Inversion Port 0 Pin 2

Inversion of port (x):

- 0 – Normal
- 1 - Inverted

5 Configuration: BNI IOL-311-002-K006 extended with BNI IOL-311-002-K006

Configuration of inputs/ outputs 41_{hex}

Byte	0							
Bit	7	6	5	4	3	2	1	0
Sub-index	8	7	6	5	4	3	2	1
Description	* Direction Port 7	Direction Port 6	Direction Port 5	Direction Port 4	Direction Port 3	Direction Port 2	Direction Port 1	Direction Port 0

* No function

Byte	1							
Bit	7	6	5	4	3	2	1	0
Sub-index	16	15	14	13	12	11	10	9
	Extension port							
Description	Direction Port 7	Direction Port 6	Direction Port 5	Direction Port 4	Direction Port 3	Direction Port 2	Direction Port 1	Direction Port 0

Direction of port (x):

- 0 - Input
- 1 - Output

5 Configuration: BNI IOL-311-002-K006 extended with BNI IOL-311-002-K006

Safe state of the outputs
42hex

The safe state parameter makes it possible to configure the outputs in case of a fault. If no IO-Link communication is possible or the "valid flag" of the output process data has not been set by the master, then each output adopts the configured status. The following statuses can be configured for each pin.

Safe state of the outputs on Pin 4 42hex

Byte	0								1							
	7	6	5	4	3	2	1	0	7	6	5	4	3	2	1	0
Sub-index	4		3		2		1		8		7		6		5	
Description	Safe state Port 3 Pin 4		Safe state Port 2 Pin 4		Safe state Port 1 Pin 4		Safe state Port 0 Pin 4		* Safe state Port 7 Pin 4		Safe state Port 6 Pin 4		Safe state Port 5 Pin 4		Safe state Port 4 Pin 4	

* No function

Byte	2								3							
	7	6	5	4	3	2	1	0	7	6	5	4	3	2	1	0
Sub-index	12		11		10		9		16		15		14		13	
Extension port																
Description	Safe state Port 3 Pin 4		Safe state Port 2 Pin 4		Safe state Port 1 Pin 4		Safe state Port 0 Pin 4		Safe state Port 7 Pin 4		Safe state Port 6 Pin 4		Safe state Port 5 Pin 4		Safe state Port 4 Pin 4	

5 Configuration: BNI IOL-311-002-K006 extended with BNI IOL-311-002-K006

Safe state of the outputs on Pin 2 43hex

Byte	0								1							
	7	6	5	4	3	2	1	0	7	6	5	4	3	2	1	0
Sub-index	4		3		2		1		8		7		6		5	
Description	Safe state Port 3 Pin 2		Safe state Port 2 Pin 2		Safe state Port 1 Pin 2		Safe state Port 0 Pin 2		* Safe state Port 7 Pin 2		Safe state Port 6 Pin 2		Safe state Port 5 Pin 2		Safe state Port 4 Pin 2	

* No function

Byte	2								3							
	7	6	5	4	3	2	1	0	7	6	5	4	3	2	1	0
Sub-index	12		11		10		9		16		15		14		13	
Extension port																
Description	Safe state Port 3 Pin 2		Safe state Port 2 Pin 2		Safe state Port 1 Pin 2		Safe state Port 0 Pin 2		Safe state Port 7 Pin 2		Safe state Port 6 Pin 2		Safe state Port 5 Pin 2		Safe state Port 4 Pin 2	

Value		Output state
bin	dec	
00	0	Output is 0V
01	1	Output is 24V
10	2	Current status is maintained
11	3	Not permitted

5 Configuration: BNI IOL-311-002-K006 extended with BNI IOL-311-002-K006

Voltage monitoring
44hex

Byte	0								1							
Bit	7	6	5	4	3	2	1	0	7	6	5	4	3	2	1	0
Sub-index	8	7	6	5	4	3	2	1					12	11		9
Description	Short-circuit Port 7 Pin 1	Short-circuit Port 6 Pin 1	Short-circuit Port 5 Pin 1	Short-circuit Port 4 Pin 1	Short-circuit Port 3 Pin 1	Short-circuit Port 2 Pin 1	Short-circuit Port 1 Pin 1	Short-circuit Port 0 Pin 1	-	-	-	-	Outputs off (UA too low)	Undervoltage UA	-	Undervoltage US

Byte	2								3							
Bit	7	6	5	4	3	2	1	0	7	6	5	4	3	2	1	0
Sub-index	24	23	22	21	20	19	18	17					28	27		25
	Extension port															
Description	Short-circuit Port 7 Pin 1	Short-circuit Port 6 Pin 1	Short-circuit Port 5 Pin 1	Short-circuit Port 4 Pin 1	Short-circuit Port 3 Pin 1	Short-circuit Port 2 Pin 1	Short-circuit Port 1 Pin 1	Short-circuit Port 0 Pin 1	-	-	-	-	Outputs off (UA too low)	Undervoltage UA	-	Undervoltage US

Output monitoring
45hex

Byte	0								1							
Bit	7	6	5	4	3	2	1	0	7	6	5	4	3	2	1	0
Sub-index	8	7	6	5	4	3	2	1	16	15	14	13	12	11	10	9
Description	* Short-circuit Port 7 Pin 4	Short-circuit Port 6 Pin 4	Short-circuit Port 5 Pin 4	Short-circuit Port 4 Pin 4	Short-circuit Port 3 Pin 4	Short-circuit Port 2 Pin 4	Short-circuit Port 1 Pin 4	Short-circuit Port 0 Pin 4	* Short-circuit Port 7 Pin 2	Short-circuit Port 6 Pin 2	Short-circuit Port 5 Pin 2	Short-circuit Port 4 Pin 2	Short-circuit Port 3 Pin 2	Short-circuit Port 2 Pin 2	Short-circuit Port 1 Pin 2	Short-circuit Port 0 Pin 2

* No function

5 Configuration: BNI IOL-311-002-K006 extended with BNI IOL-311-002-K006

Byte	2								3							
Bit	7	6	5	4	3	2	1	0	7	6	5	4	3	2	1	0
Sub-index	24	23	22	21	20	19	18	17	32	31	30	29	28	27	26	25
	Extension port															
Description	Short-circuit Port 7 Pin 4	Short-circuit Port 6 Pin 4	Short-circuit Port 5 Pin 4	Short-circuit Port 4 Pin 4	Short-circuit Port 3 Pin 4	Short-circuit Port 2 Pin 4	Short-circuit Port 1 Pin 4	Short-circuit Port 0 Pin 4	Short-circuit Port 7 Pin 2	Short-circuit Port 6 Pin 2	Short-circuit Port 5 Pin 2	Short-circuit Port 4 Pin 2	Short-circuit Port 3 Pin 2	Short-circuit Port 2 Pin 2	Short-circuit Port 1 Pin 2	Short-circuit Port 0 Pin 2

Actuator warning 46_{hex}

Byte	0								1							
Bit	7	6	5	4	3	2	1	0	7	6	5	4	3	2	1	0
Sub-index	8	7	6	5	4	3	2	1	16	15	14	13	12	11	10	9
Description	* Warning Port 7 Pin 4	Warning Port 6 Pin 4	Warning Port 5 Pin 4	Warning Port 4 Pin 4	Warning Port 3 Pin 4	Warning Port 2 Pin 4	Warning Port 1 Pin 4	Warning Port 0 Pin 4	* Warning Port 7 Pin 2	Warning Port 6 Pin 2	Warning Port 5 Pin 2	Warning Port 4 Pin 2	Warning Port 3 Pin 2	Warning Port 2 Pin 2	Warning Port 1 Pin 2	Warning Port 0 Pin 2

* No function

Byte	2								3							
Bit	7	6	5	4	3	2	1	0	7	6	5	4	3	2	1	0
Sub-index	24	23	22	21	20	19	18	17	32	31	30	29	28	27	26	25
	Extension port															
Description	Warning Port 7 Pin 4	Warning Port 6 Pin 4	Warning Port 5 Pin 4	Warning Port 4 Pin 4	Warning Port 3 Pin 4	Warning Port 2 Pin 4	Warning Port 1 Pin 4	Warning Port 0 Pin 4	Warning Port 7 Pin 2	Warning Port 6 Pin 2	Warning Port 5 Pin 2	Warning Port 4 Pin 2	Warning Port 3 Pin 2	Warning Port 2 Pin 2	Warning Port 1 Pin 2	Warning Port 0 Pin 2

5 Configuration: BNI IOL-311-002-K006 extended with BNI IOL-311-002-K006

Setting the serial number 54_{hex}

The serial number has a default value of 16x00_{hex}.
 In order to use the "Identity" master validation mode, a serial number can be set using this parameter.
 This prevents a device from connecting to the wrong master port.

Configuration of the extension port 55_{hex}

Configuration	Index 55 _{hex} value
BNI IOL-311-002-K006	0
BNI IOL-311-002-K006 with BNI IOL-311-002-K006	1
BNI IOL-311-002-K006 with BNI IOL-751-V08-K007	2
BNI IOL-311-002-K006 with BNI IOL-751-V10-K007	3
BNI IOL-311-002-K006 with BNI IOL-751-V13-K007	4



Note

The "Factory reset" command does not affect the configuration of the extension port in any way.

6 Configuration: BNI IOL-311-002-K006 extended with valve terminal connector with 22/24 valves



6.1. IO-Link Data

BNI IOL-311-002-K006 extended with valve terminal connector with 22/24 valves	
Transfer rate	COM2 (38.4 kbaud)
Minimum cycle time	4.5 ms
Process data length	2 byte input, 6 byte output

6.2. Process Data/
Input Data

Process data length of 2 bytes:

Byte	0								1							
	Bit	7	6	5	4	3	2	1	0	7	6	5	4	3	2	1
Description	-	Input Port 6 Pin 4	Input Port 5 Pin 4	Input Port 4 Pin 4	Input Port 3 Pin 4	Input Port 2 Pin 4	Input Port 1 Pin 4	Input Port 0 Pin 4	-	Input Port 6 Pin 2	Input Port 5 Pin 2	Input Port 4 Pin 2	Input Port 3 Pin 2	Input Port 2 Pin 2	Input Port 1 Pin 2	Input Port 0 Pin 2

6.3. Process Data/
Output Data

Process data length of 6 bytes:

Byte	0								1							
	Bit	7	6	5	4	3	2	1	0	7	6	5	4	3	2	1
Description	-	Output Port 6 Pin 4	Output Port 5 Pin 4	Output Port 4 Pin 4	Output Port 3 Pin 4	Output Port 2 Pin 4	Output Port 1 Pin 4	Output Port 0 Pin 4	-	Output Port 6 Pin 2	Output Port 5 Pin 2	Output Port 4 Pin 2	Output Port 3 Pin 2	Output Port 2 Pin 2	Output Port 1 Pin 2	Output Port 0 Pin 2

6 Configuration: BNI IOL-311-002-K006 extended with valve terminal connector with 22/24 valves

Byte	2								3							
Bit	7	6	5	4	3	2	1	0	7	6	5	4	3	2	1	0
	Valve terminal on the Extension port															
Description	* Valve 12 – Coil A	Valve 11 – Coil A	Valve 10 – Coil A	Valve 09 – Coil A	Valve 08 – Coil A	Valve 07 – Coil A	Valve 06 – Coil A	Valve 05 – Coil A	Valve 04 – Coil A	Valve 03 – Coil A	Valve 02 – Coil A	Valve 01 – Coil A

* No function for V013

Byte	4								5							
Bit	7	6	5	4	3	2	1	0	7	6	5	4	3	2	1	0
	Valve terminal on the Extension port															
Description	* Valve 12 – Coil B	Valve 11 – Coil B	Valve 10 – Coil B	Valve 09 – Coil B	Valve 08 – Coil B	Valve 07 – Coil B	Valve 06 – Coil B	Valve 05 – Coil B	Valve 04 – Coil B	Valve 03 – Coil B	Valve 02 – Coil B	Valve 01 – Coil B

* No function for V013

6 Configuration: BNI IOL-311-002-K006 extended with valve terminal connector with 22/24 valves

6.4. Parameter Data / Demand Data

	DPP	SPDU		Parameter	Data width	Access rights	Default value
	Index	Index	Sub-index				
Identification data	07hex			Vendor ID	2 bytes	Read only	0378hex
	08hex						
	09hex			Device ID	3 bytes		
	0Ahex						
	0Bhex					Read /write	0hex
		0Chex 12	0	Device Access Locks	2 bytes		
		10hex 16	0	Vendor Name	7 bytes	Read only	BALLUFF
		11hex 17	0	Vendor text	15 bytes		www.balluff.com
		12hex 18	0	Product name			BNI IOL-311-002-K006 with BNI IOL-751-V08-K007 BNI IOL-311-002-K006 with BNI IOL-751-V10-K007 BNI IOL-311-002-K006 with BNI IOL-751-V13-K007
		13hex 19	0	Product ID	7 bytes		BNI00AF with BNI006N BNI00AF with BNI006P BNI00AF with BNI006R
		14hex 20	0	Product text			Sensor/Actor NPN Hub M12 with BNI IOL-751-V08-K007 Sensor/Actor NPN Hub M12 with BNI IOL-751-V10-K007 Sensor/Actor NPN Hub M12 with BNI IOL-751-V13-K007
		15hex 21	0	Serial number	16 bytes		0hex
		16hex 22	0	Hardware Revision			
		17hex 23	0	Firmware Revision			
	18hex 24	0	Application Specific Tag	32 bytes	Read / Write		0hex

	DPP	SPDU		Parameter	Data width	Access rights	Default Value
	Index	Index	Subindex				
Parameter data		40hex 64	0 1-16	Inversion of the inputs	2 bytes	Read / Write	0hex
		41hex 65	0 1-8	Config. inputs/outputs	1 byte	Read / Write	0hex
		42hex 66	0 1-32	Safe state on Pin 4	10 bytes	Read / Write	0hex
		43hex 67	0 1-8	Safe state on Pin 2	2 bytes	Read / Write	0hex
		44hex 68	0 1-23	Voltage monitoring	3 bytes	Read	-
		45hex 69	0 1-40	Output monitoring	6 bytes	Read	-
		46hex 70	0 1-16	Actuator warning	2 bytes	Read	-
		54hex 84	0	Serial number	16 bytes	Read / Write	16x00hex
		55hex 85	0	Extension port	1 byte	Read / Write	2, 3, 4hex

6 Configuration: BNI IOL-311-002-K006 extended with valve terminal connector with 22/24 valves

Device Access Locks 0Chex

The parameter Device Access Locks allows control of the Device behavior. Only Data Storage standardized device functions can be configured via the defined flag in this parameter. The Device Access Locks configuration can be changed by overwriting the parameter. The actual configuration setting is available per read access to this parameter. Access is only permitted via Subindex 0.

Inversion of the inputs 40hex

Byte	0								1							
Bit	7	6	5	4	3	2	1	0	7	6	5	4	3	2	1	0
Sub-index	8	7	6	5	4	3	2	1	16	15	14	13	12	11	10	9
Description	* Inversion Port 7 Pin 4	Inversion Port 6 Pin 4	Inversion Port 5 Pin 4	Inversion Port 4 Pin 4	Inversion Port 3 Pin 4	Inversion Port 2 Pin 4	Inversion Port 1 Pin 4	Inversion Port 0 Pin 4	* Inversion Port 7 Pin 2	Inversion Port 6 Pin 2	Inversion Port 5 Pin 2	Inversion Port 4 Pin 2	Inversion Port 3 Pin 2	Inversion Port 2 Pin 2	Inversion Port 1 Pin 2	Inversion Port 0 Pin 2

* No function

Inversion of port (x):

- 0 - Normal
- 1 - Inverted

Configuration of inputs/ outputs 41hex

Byte	0							
Bit	7	6	5	4	3	2	1	0
Sub-index	8	7	6	5	4	3	2	1
Description	* Direction Port 7	Direction Port 6	Direction Port 5	Direction Port 4	Direction Port 3	Direction Port 2	Direction Port 1	Direction Port 0

* No function

Direction of port (x):

- 0 - Input
- 1 - Output

6 Configuration: BNI IOL-311-002-K006 extended with valve terminal connector with 22/24 valves

Safe state of the outputs 42hex

The safe state parameter makes it possible to configure the outputs in case of a fault. If no IO-Link communication is possible or the "valid flag" of the output process data has not been set by the master, then each output adopts the configured status. The following statuses can be configured for each pin.

Safe state of the outputs on Pin 4 42hex

Byte	0								1							
Bit	7	6	5	4	3	2	1	0	7	6	5	4	3	2	1	0
Sub-index	4		3		2		1		8		7		6		5	
Description	Safe state Port 3 Pin 4		Safe state Port 2 Pin 4		Safe state Port 1 Pin 4		Safe state Port 0 Pin 4		* Safe state Port 7 Pin 4		Safe state Port 6 Pin 4		Safe state Port 5 Pin 4		Safe state Port 4 Pin 4	

* No function

Byte	2								3							
Bit	7	6	5	4	3	2	1	0	7	6	5	4	3	2	1	0
Sub-index									31		29		27		25	
Valve terminal on the extension port																
Description		* Valve 12 – Coil A		Valve 11 – Coil A		Valve 10 – Coil A		Valve 09 – Coil A	

* No function for V013

Byte	4								5							
Bit	7	6	5	4	3	2	1	0	7	6	5	4	3	2	1	0
Sub-index	23		21		19		17		15		13		11		9	
Valve terminal on the extension port																
Description	Valve 08 – Coil A		Valve 07 – Coil A		Valve 06 – Coil A		Valve 05 – Coil A		Valve 04 – Coil A		Valve 03 – Coil A		Valve 02 – Coil A		Valve 01 – Coil A	

6 Configuration: BNI IOL-311-002-K006 extended with valve terminal connector with 22/24 valves

Byte	6								7							
Bit	7	6	5	4	3	2	1	0	7	6	5	4	3	2	1	0
Sub-index									32		30		28		26	
	Valve terminal on the extension port															
Description									* Valve 12 – Coil B		Valve 11 – Coil B		Valve 10 – Coil B		Valve 09 – Coil B	

* No function for V013

Byte	8								9							
Bit	7	6	5	4	3	2	1	0	7	6	5	4	3	2	1	0
Sub-index	24		22		20		18		16		14		12		10	
	Valve terminal on the extension port															
Description	Valve 08 – Coil B		Valve 07 – Coil B		Valve 06 – Coil B		Valve 05 – Coil B		Valve 04 – Coil B		Valve 03 – Coil B		Valve 02 – Coil B		Valve 01 – Coil B	

Safe state of the outputs on Pin 2 43_{hex}

Byte	0								1							
Bit	7	6	5	4	3	2	1	0	7	6	5	4	3	2	1	0
Sub-index	4		3		2		1		8		7		6		5	
Description	Safe state Port 3 Pin 2		Safe state Port 2 Pin 2		Safe state Port 1 Pin 2		Safe state Port 0 Pin 2		* Safe state Port 7 Pin 2		Safe state Port 6 Pin 2		Safe state Port 5 Pin 2		Safe state Port 4 Pin 2	

* No function

Value		Output state
bin	dec	
00	0	Output is 0V
01	1	Output is 24V
10	2	Current status is maintained
11	3	Not defined

6 Configuration: BNI IOL-311-002-K006 extended with valve terminal connector with 22/24 valves

Voltage monitoring
44hex

Byte	0								1							
Bit	7	6	5	4	3	2	1	0	7	6	5	4	3	2	1	0
Sub-index	8	7	6	5	4	3	2	1					12	11		9
Description	Short-circuit Port 7 Pin 1	Short-circuit Port 6 Pin 1	Short-circuit Port 5 Pin 1	Short-circuit Port 4 Pin 1	Short-circuit Port 3 Pin 1	Short-circuit Port 2 Pin 1	Short-circuit Port 1 Pin 1	Short-circuit Port 0 Pin 1	-	-	-	-	Outputs off (UA too low)	Undervoltage UA	-	Undervoltage US

Byte	2							
Bit	7	6	5	4	3	2	1	0
Sub-index		23				19		17
Valve terminal on the extension port								
Description	-	Overload UA	-	-	-	Undervoltage UA	-	Undervoltage US

6 Configuration: BNI IOL-311-002-K006 extended with valve terminal connector with 22/24 valves

Output monitoring
45hex

Byte	0								1							
Bit	7	6	5	4	3	2	1	0	7	6	5	4	3	2	1	0
Sub-index	8	7	6	5	4	3	2	1	16	15	14	13	12	11	10	9
Description	* Short-circuit Port 7 Pin 4	Short-circuit Port 6 Pin 4	Short-circuit Port 5 Pin 4	Short-circuit Port 4 Pin 4	Short-circuit Port 3 Pin 4	Short-circuit Port 2 Pin 4	Short-circuit Port 1 Pin 4	Short-circuit Port 0 Pin 4	Short-circuit Port 7 Pin 2	Short-circuit Port 6 Pin 2	Short-circuit Port 5 Pin 2	Short-circuit Port 4 Pin 2	Short-circuit Port 3 Pin 2	Short-circuit Port 2 Pin 2	Short-circuit Port 1 Pin 2	Short-circuit Port 0 Pin 2

* No function

Byte	2								3							
Bit	7	6	5	4	3	2	1	0	7	6	5	4	3	2	1	0
Sub-index					39	37	35	33	31	29	27	25	23	21	19	17
Valve terminal on the extension port																
Description	-	-	-	-	* Valve 12 – Coil A	Valve 11 – Coil A	Valve 10 – Coil A	Valve 09 – Coil A	Valve 08 – Coil A	Valve 07 – Coil A	Valve 06 – Coil A	Valve 05 – Coil A	Valve 04 – Coil A	Valve 03 – Coil A	Valve 02 – Coil A	Valve 01 – Coil A

* No function for V013

Byte	4								5							
Bit	7	6	5	4	3	2	1	0	7	6	5	4	3	2	1	0
Sub-index					40	38	36	34	32	30	28	26	24	22	20	18
Valve terminal on the extension port																
Description	-	-	-	-	* Valve 12 – Coil B	Valve 11 – Coil B	Valve 10 – Coil B	Valve 09 – Coil B	Valve 08 – Coil B	Valve 07 – Coil B	Valve 06 – Coil B	Valve 05 – Coil B	Valve 04 – Coil B	Valve 03 – Coil B	Valve 02 – Coil B	Valve 01 – Coil B

* No function for V013

6 Configuration: BNI IOL-311-002-K006 extended with valve terminal connector with 22/24 valves

Actuator warning
46hex

Byte	0								1							
Bit	7	6	5	4	3	2	1	0	7	6	5	4	3	2	1	0
Sub-index	8	7	6	5	4	3	2	1	16	15	14	13	12	11	10	9
Description	* Warning Port 7 Pin 4	Warning Port 6 Pin 4	Warning Port 5 Pin 4	Warning Port 4 Pin 4	Warning Port 3 Pin 4	Warning Port 2 Pin 4	Warning Port 1 Pin 4	Warning Port 0 Pin 4	* Warning Port 7 Pin 2	Warning Port 6 Pin 2	Warning Port 5 Pin 2	Warning Port 4 Pin 2	Warning Port 3 Pin 2	Warning Port 2 Pin 2	Warning Port 1 Pin 2	Warning Port 0 Pin 2

* No function

Setting the serial number 54hex

The serial number has a default value of 16x00hex. In order to use the "Identity" master validation mode, a serial number can be set using this parameter. This prevents a device from connecting to the wrong master port.

Configuration of the extension port 55hex

Configuration	Index 55hex value
BNI IOL-311-002-K006	0
BNI IOL-311-002-K006 with BNI IOL-311-002-K006	1
BNI IOL-311-002-K006 with BNI IOL-751-V08-K007	2
BNI IOL-311-002-K006 with BNI IOL-751-V10-K007	3
BNI IOL-311-002-K006 with BNI IOL-751-V13-K007	4



Note

The "Factory reset" command does not affect the configuration of the extension port in any way.

7 Configuration: BNI IOL-311-S02-K006-C01



7.1. IO-Link Data

BNI IOL-311-S02-K006-C01	
Transfer rate	COM2 (38.4 kbaud)
Minimum cycle time	6 ms
Process data length	10 byte input, 2 byte output

7.2. Process Data/
Input Data

BNI IOL-311-S02-K006-C01
Process data length of 10 bytes:

Byte	0								1							
Bit	7	6	5	4	3	2	1	0	7	6	5	4	3	2	1	0
Description	Input Port 7 Pin 4	Input Port 6 Pin 4	Input Port 5 Pin 4	Input Port 4 Pin 4	Input Port 3 Pin 4	Input Port 2 Pin 4	Input Port 1 Pin 4	Input Port 0 Pin 4	Input Port 7 Pin 2	Input Port 6 Pin 2	Input Port 5 Pin 2	Input Port 4 Pin 2	Input Port 3 Pin 2	Input Port 2 Pin 2	Input Port 1 Pin 2	Input Port 0 Pin 2

Byte	2								3							
Bit	7	6	5	4	3	2	1	0	7	6	5	4	3	2	1	0
Description	Short-circuit Port 7 Pin 1	Short-circuit Port 6 Pin 1	Short-circuit Port 5 Pin 1	Short-circuit Port 4 Pin 1	Short-circuit Port 3 Pin 1	Short-circuit Port 2 Pin 1	Short-circuit Port 1 Pin 1	Short-circuit Port 0 Pin 1	-	-	-	-	Outputs off (UA too low)	Undervoltage UA	-	Undervoltage US

7 Configuration: BNI IOL-311-S02-K006-C01

Byte	4								5							
Bit	7	6	5	4	3	2	1	0	7	6	5	4	3	2	1	0
Description	Short-circuit Port 7 Pin 4	Short-circuit Port 6 Pin 4	Short-circuit Port 5 Pin 4	Short-circuit Port 4 Pin 4	Short-circuit Port 3 Pin 4	Short-circuit Port 2 Pin 4	Short-circuit Port 1 Pin 4	Short-circuit Port 0 Pin 4	Short-circuit Port 7 Pin 2	Short-circuit Port 6 Pin 2	Short-circuit Port 5 Pin 2	Short-circuit Port 4 Pin 2	Short-circuit Port 3 Pin 2	Short-circuit Port 2 Pin 2	Short-circuit Port 1 Pin 2	Short-circuit Port 0 Pin 2

Byte	6								7							
Bit	7	6	5	4	3	2	1	0	7	6	5	4	3	2	1	0
Description	Warning Port 7 Pin 4	Warning Port 6 Pin 4	Warning Port 5 Pin 4	Warning Port 4 Pin 4	Warning Port 3 Pin 4	Warning Port 2 Pin 4	Warning Port 1 Pin 4	Warning Port 0 Pin 4	Warning Port 7 Pin 2	Warning Port 6 Pin 2	Warning Port 5 Pin 2	Warning Port 4 Pin 2	Warning Port 3 Pin 2	Warning Port 2 Pin 2	Warning Port 1 Pin 2	Warning Port 0 Pin 2

Byte	8								9							
Bit	7	6	5	4	3	2	1	0	7	6	5	4	3	2	1	0
Description	Identification Byte0								Identification Byte1							

7.3. Process Data/
Output Data

BNI IOL-311-S02-K006-C01

Process data length of 2 bytes:

Byte	0								1							
Bit	7	6	5	4	3	2	1	0	7	6	5	4	3	2	1	0
Description	Output Port 7 Pin 4	Output Port 6 Pin 4	Output Port 5 Pin 4	Output Port 4 Pin 4	Output Port 3 Pin 4	Output Port 2 Pin 4	Output Port 1 Pin 4	Output Port 0 Pin 4	Output Port 7 Pin 2	Output Port 6 Pin 2	Output Port 5 Pin 2	Output Port 4 Pin 2	Output Port 3 Pin 2	Output Port 2 Pin 2	Output Port 1 Pin 2	Output Port 0 Pin 2

7 Configuration: BNI IOL-311-S02-K006-C01

7.4. Parameter Data/
Demand Data

	DPP	SPDU		Parameter	Data width	Access rights	Default value
	Index	Index	Sub-index				
Identification data	07hex			Vendor ID	2 bytes	Read only	0378hex
	08hex						
	09hex			Device ID	3 bytes		0x05 0B E0
	0Ahex						
	0Bhex						
		0Chex 12	0	Device Access Locks	2 bytes	Read/Write	0hex
		10hex 16	0	Vendor name	7 bytes	Read only	BALLUFF
		11hex 17	0	Vendor text	15 bytes		www.balluff.com
		12hex 18	0	Product name			BNI IOL-311-S02-K006-C01
		13hex 19	0	Product ID	7 bytes		BNI00AW
		14hex 20	0	Product text			Sensor/Actor NPN Hub M12 ext. diag.
		15hex 21	0	Serial number	16 bytes		0hex
		16hex 22	0	Hardware revision			
		17hex 23	0	Firmware revision			
	18hex 24	0	Application Specific Tag	32 bytes	Read / Write	0hex	

	DPP	SPDU		Parameter	Data width	Access rights	Default Value
	Index	Index	Sub-index				
Parameter data		40hex 64	0 1-16	Inversion of the inputs	2 bytes	Read / Write	0hex
		41hex 65	0 1-8	Config. inputs/outputs	1 byte	Read / Write	0hex
		42hex 66	0 1-8	Pin 4 safe state	2 bytes	Read / Write	0hex
		43hex 67	0 1-8	Pin 2 safe state	2 bytes	Read / Write	0hex
		44hex 68	0 1-16	Voltage monitoring	2 bytes	Read	-
		45hex 69	0 1-16	Output monitoring	2 bytes	Read	-
		46hex 70	0 1-16	Actuator warning	2 bytes	Read	-
		54hex 84	0	Serial number	16 bytes	Read / Write	16x00hex
		55hex 85	0	Extension port	1 byte	Read / Write	0hex
		60hex 96	0 1-16	Identification	2 bytes	Read / Write	0hex

7 Configuration: BNI IOL-311-S02-K006-C01

Device Access Locks 0C_{hex}

The parameter Device Access Locks allows control of the Device behavior. Only Data Storage standardized device functions can be configured via the defined flag in this parameter. The Device Access Locks configuration can be changed by overwriting the parameter. The actual configuration setting is available per read access to this parameter. Access is only permitted via Subindex 0.

Inversion of the inputs 40_{hex}

Byte	0								1							
Bit	7	6	5	4	3	2	1	0	7	6	5	4	3	2	1	0
Sub-index	8	7	6	5	4	3	2	1	16	15	14	13	12	11	10	9
Description	Inversion Port 7 Pin 4	Inversion Port 6 Pin 4	Inversion Port 5 Pin 4	Inversion Port 4 Pin 4	Inversion Port 3 Pin 4	Inversion Port 2 Pin 4	Inversion Port 1 Pin 4	Inversion Port 0 Pin 4	Inversion Port 7 Pin 2	Inversion Port 6 Pin 2	Inversion Port 5 Pin 2	Inversion Port 4 Pin 2	Inversion Port 3 Pin 2	Inversion Port 2 Pin 2	Inversion Port 1 Pin 2	Inversion Port 0 Pin 2

Inversion of port (x):

0 – Normal
1 - Inverted

Configuration of inputs /outputs 41_{hex}

Byte	0							
Bit	7	6	5	4	3	2	1	0
Sub-index	8	7	6	5	4	3	2	1
Description	Direction Port 7	Direction Port 6	Direction Port 5	Direction Port 4	Direction Port 3	Direction Port 2	Direction Port 1	Direction Port 0

Direction of port (x):

0 – Input
1 – Output

7 Configuration: BNI IOL-311-S02-K006-C01

Safe state of the outputs
42_{hex}

The safe state parameter makes it possible to configure the outputs in case of a fault. If no IO-Link communication is possible or the "valid flag" of the output process data has not been set by the master, then each output adopts the configured status. The following statuses can be configured for each pin.

Safe state of the outputs on Pin 4 42_{hex}

Byte	0								1							
	7	6	5	4	3	2	1	0	7	6	5	4	3	2	1	0
Sub-index	4		3		2		1		8		7		6		5	
Description	Safe state Port 3 Pin 4		Safe state Port 2 Pin 4		Safe state Port 1 Pin 4		Safe state Port 0 Pin 4		Safe state Port 7 Pin 4		Safe state Port 6 Pin 4		Safe state Port 5 Pin 4		Safe state Port 4 Pin 4	

Safe state of the outputs on Pin 2 43_{hex}

Byte	0								1							
	7	6	5	4	3	2	1	0	7	6	5	4	3	2	1	0
Sub-index	4		3		2		1		8		7		6		5	
Description	Safe state Port 3 Pin 2		Safe state Port 2 Pin 2		Safe state Port 1 Pin 2		Safe state Port 0 Pin 2		Safe state Port 7 Pin 2		Safe state Port 6 Pin 2		Safe state Port 5 Pin 2		Safe state Port 4 Pin 2	

Value		Output state
bin	dec	
00	0	Output is 0V
01	1	Output is 24V
10	2	Current status is maintained
11	3	Not defined

7 Configuration: BNI IOL-311-S02-K006-C01

Voltage monitoring
44hex

Byte	0								1							
Bit	7	6	5	4	3	2	1	0	7	6	5	4	3	2	1	0
Sub-index	8	7	6	5	4	3	2	1					12	11		9
Description	Short-circuit Port 7 Pin 1	Short-circuit Port 6 Pin 1	Short-circuit Port 5 Pin 1	Short-circuit Port 4 Pin 1	Short-circuit Port 3 Pin 1	Short-circuit Port 2 Pin 1	Short-circuit Port 1 Pin 1	Short-circuit Port 0 Pin 1	-	-	-	-	Outputs off (UA too low)	Undervoltage UA	-	Undervoltage US

Output monitoring
45hex

Byte	0								1							
Bit	7	6	5	4	3	2	1	0	7	6	5	4	3	2	1	0
Sub-index	8	7	6	5	4	3	2	1	16	15	14	13	12	11	10	9
Description	Short-circuit Port 7 Pin 4	Short-circuit Port 6 Pin 4	Short-circuit Port 5 Pin 4	Short-circuit Port 4 Pin 4	Short-circuit Port 3 Pin 4	Short-circuit Port 2 Pin 4	Short-circuit Port 1 Pin 4	Short-circuit Port 0 Pin 4	Short-circuit Port 7 Pin 2	Short-circuit Port 6 Pin 2	Short-circuit Port 5 Pin 2	Short-circuit Port 4 Pin 2	Short-circuit Port 3 Pin 2	Short-circuit Port 2 Pin 2	Short-circuit Port 1 Pin 2	Short-circuit Port 0 Pin 2

Actuator warning
46hex

Byte	0								1							
Bit	7	6	5	4	3	2	1	0	7	6	5	4	3	2	1	0
Sub-index	8	7	6	5	4	3	2	1	16	15	14	13	12	11	10	9
Description	Warning Port 7 Pin 4	Warning Port 6 Pin 4	Warning Port 5 Pin 4	Warning Port 4 Pin 4	Warning Port 3 Pin 4	Warning Port 2 Pin 4	Warning Port 1 Pin 4	Warning Port 0 Pin 4	Warning Port 7 Pin 2	Warning Port 6 Pin 2	Warning Port 5 Pin 2	Warning Port 4 Pin 2	Warning Port 3 Pin 2	Warning Port 2 Pin 2	Warning Port 1 Pin 2	Warning Port 0 Pin 2

7 Configuration: BNI IOL-311-S02-K006-C01

Setting the serial number 54hex

The serial number has a default value of 16x00hex.
 In order to use the "Identity" master validation mode, a serial number can be set using this parameter.
 This prevents a device from connecting to the wrong master port.

Configuration of the extension port 55hex

Configuration	Index 55hex value
BNI IOL-311-S02-K006-C01	0
BNI IOL-311-S02-K006-C01 with BNI IOL-311-S02-K006-C01	1
BNI IOL-311-S02-K006-C01 with BNI IOL-751-V08-K007	2
BNI IOL-311-S02-K006-C01 with BNI IOL-751-V10-K007	3
BNI IOL-311-S02-K006-C01 with BNI IOL-751-V13-K007	4



Note

The "Factory reset" command does not affect the configuration of the extension port in any way.

Identification 60hex

Byte	0								1							
	7	6	5	4	3	2	1	0	7	6	5	4	3	2	1	0
Description	Identification Byte0								Identification Byte1							

8 Configuration: BNI IOL-311-S02-K006-C01 extended with BNI IOL-311-S02-K006-C01



8.1. IO-Link Data

BNI IOL-311-S02-K006-C01 extended with BNI IOL-311-S02-K006-C01	
Transfer rate	COM2 (38.4 kbaud)
Minimum cycle time	8.4 ms
Process data length	20 byte input, 4 byte output

8.2. Process Data/
Input Data

Process data length of 20 bytes:

Byte	0								1							
Bit	7	6	5	4	3	2	1	0	7	6	5	4	3	2	1	0
Description	-	Input Port 6 pin 4	Input Port 5 pin 4	Input Port 4 pin 4	Input Port 3 pin 4	Input Port 2 pin 4	Input Port 1 pin 4	Input Port 0 pin 4	-	Input Port 6 pin 2	Input Port 5 pin 2	Input Port 4 pin 2	Input Port 3 pin 2	Input Port 2 pin 2	Input Port 1 pin 2	Input Port 0 pin 2

Byte	2								3							
Bit	7	6	5	4	3	2	1	0	7	6	5	4	3	2	1	0
	Extension port															
Description	Input Port 7 pin 4	Input Port 6 pin 4	Input Port 5 pin 4	Input Port 4 pin 4	Input Port 3 pin 4	Input Port 2 pin 4	Input Port 1 pin 4	Input Port 0 pin 4	Input Port 7 pin 2	Input Port 6 pin 2	Input Port 5 pin 2	Input Port 4 pin 2	Input Port 3 pin 2	Input Port 2 pin 2	Input Port 1 pin 2	Input Port 0 pin 2

8 Configuration: BNI IOL-311-S02-K006-C01 extended with BNI IOL-311-S02-K006-C01

Byte	4								5							
Bit	7	6	5	4	3	2	1	0	7	6	5	4	3	2	1	0
Description	Short-circuit Port 7 Pin 1	Short-circuit Port 6 Pin 1	Short-circuit Port 5 Pin 1	Short-circuit Port 4 Pin 1	Short-circuit Port 3 Pin 1	Short-circuit Port 2 Pin 1	Short-circuit Port 1 Pin 1	Short-circuit Port 0 Pin 1	-	-	-	-	Outputs off (UA too low)	Undervoltage UA	-	Undervoltage US

Byte	6								7							
Bit	7	6	5	4	3	2	1	0	7	6	5	4	3	2	1	0
Extension port																
Description	Short-circuit Port 7 Pin 1	Short-circuit Port 6 Pin 1	Short-circuit Port 5 Pin 1	Short-circuit Port 4 Pin 1	Short-circuit Port 3 Pin 1	Short-circuit Port 2 Pin 1	Short-circuit Port 1 Pin 1	Short-circuit Port 0 Pin 1	-	-	-	-	Outputs off (UA too low)	Undervoltage UA	-	Undervoltage US

Byte	8								9							
Bit	7	6	5	4	3	2	1	0	7	6	5	4	3	2	1	0
Description	* Short-circuit Port 7 Pin 4	Short-circuit Port 6 Pin 4	Short-circuit Port 5 Pin 4	Short-circuit Port 4 Pin 4	Short-circuit Port 3 Pin 4	Short-circuit Port 2 Pin 4	Short-circuit Port 1 Pin 4	Short-circuit Port 0 Pin 4	* Short-circuit Port 7 Pin 2	Short-circuit Port 6 Pin 2	Short-circuit Port 5 Pin 2	Short-circuit Port 4 Pin 2	Short-circuit Port 3 Pin 2	Short-circuit Port 2 Pin 2	Short-circuit Port 1 Pin 2	Short-circuit Port 0 Pin 2

* No function

8 Configuration: BNI IOL-311-S02-K006-C01 extended with BNI IOL-311-S02-K006-C01

Byte	10								11																							
Bit	7	6	5	4	3	2	1	0	7	6	5	4	3	2	1	0																
	Extension port																															
Description	Short-circuit Port 7 Pin 4		Short-circuit Port 6 Pin 4		Short-circuit Port 5 Pin 4		Short-circuit Port 4 Pin 4		Short-circuit Port 3 Pin 4		Short-circuit Port 2 Pin 4		Short-circuit Port 1 Pin 4		Short-circuit Port 0 Pin 4		Short-circuit Port 7 Pin 2		Short-circuit Port 6 Pin 2		Short-circuit Port 5 Pin 2		Short-circuit Port 4 Pin 2		Short-circuit Port 3 Pin 2		Short-circuit Port 2 Pin 2		Short-circuit Port 1 Pin 2		Short-circuit Port 0 Pin 2	

Byte	12								13																							
Bit	7	6	5	4	3	2	1	0	7	6	5	4	3	2	1	0																
Description	* Warning Port 7 Pin 4		Warning Port 6 Pin 4		Warning Port 5 Pin 4		Warning Port 4 Pin 4		Warning Port 3 Pin 4		Warning Port 2 Pin 4		Warning Port 1 Pin 4		Warning Port 0 Pin 4		* Warning Port 7 Pin 2		Warning Port 6 Pin 2		Warning Port 5 Pin 2		Warning Port 4 Pin 2		Warning Port 3 Pin 2		Warning Port 2 Pin 2		Warning Port 1 Pin 2		Warning Port 0 Pin 2	

* No function

Byte	14								15																							
Bit	7	6	5	4	3	2	1	0	7	6	5	4	3	2	1	0																
	Extension port																															
Description	Warning Port 7 Pin 4		Warning Port 6 Pin 4		Warning Port 5 Pin 4		Warning Port 4 Pin 4		Warning Port 3 Pin 4		Warning Port 2 Pin 4		Warning Port 1 Pin 4		Warning Port 0 Pin 4		Warning Port 7 Pin 2		Warning Port 6 Pin 2		Warning Port 5 Pin 2		Warning Port 4 Pin 2		Warning Port 3 Pin 2		Warning Port 2 Pin 2		Warning Port 1 Pin 2		Warning Port 0 Pin 2	

Byte	16								17							
Bit	7	6	5	4	3	2	1	0	7	6	5	4	3	2	1	0
Description	Identification Byte0								Identification Byte1							

8 Configuration: BNI IOL-311-S02-K006-C01 extended with BNI IOL-311-S02-K006-C01

Byte	18								19							
Bit	7	6	5	4	3	2	1	0	7	6	5	4	3	2	1	0
	Extension port															
Description	Identification Byte0								Identification Byte1							

8.3. Process Data / Output Data Process data length of 4 bytes:

Byte	0								1							
Bit	7	6	5	4	3	2	1	0	7	6	5	4	3	2	1	0
Description	-	Output Port 6 Pin 4	Output Port 5 Pin 4	Output Port 4 Pin 4	Output Port 3 Pin 4	Output Port 2 Pin 4	Output Port 1 Pin 4	Output Port 0 Pin 4	-	Output Port 6 Pin 2	Output Port 5 Pin 2	Output Port 4 Pin 2	Output Port 3 Pin 2	Output Port 2 Pin 2	Output Port 1 Pin 2	Output Port 0 Pin 2

Byte	2								3							
Bit	7	6	5	4	3	2	1	0	7	6	5	4	3	2	1	0
	Extension port															
Description	Output Port 7 Pin 4	Output Port 6 Pin 4	Output Port 5 Pin 4	Output Port 4 Pin 4	Output Port 3 Pin 4	Output Port 2 Pin 4	Output Port 1 Pin 4	Output Port 0 Pin 4	Output Port 7 Pin 2	Output Port 6 Pin 2	Output Port 5 Pin 2	Output Port 4 Pin 2	Output Port 3 Pin 2	Output Port 2 Pin 2	Output Port 1 Pin 2	Output Port 0 Pin 2

8 Configuration: BNI IOL-311-S02-K006-C01 extended with BNI IOL-311-S02-K006-C01

8.4. Parameter Data/
Demand Data

	DPP	SPDU		Parameter	Data width	Access rights	Default value
	Index	Index	Sub-index				
Identification data	07hex			Vendor ID	2 bytes	Read only	0378hex
	08hex						
	09hex			Device ID	3 bytes		0x05 0B E1
	0Ahex						
	0Bhex						
		0Chex 12	0	Device Access Locks	2 bytes	Read/Write	0hex
		10hex 16	0	Vendor Name	7 bytes	Read only	BALLUFF
		11hex 17	0	Vendor text	15 bytes		www.balluff.com
		12hex 18	0	Product Name			BNI IOL-311-S02-K006-C01 with BNI IOL-311-S02-K006-C01
		13hex 19	0	Product ID	7 bytes		BNI00AW with BNI00AW
		14hex 20	0	Product text			Sensor/Actor NPN Hub M12 ext. diag. with NPN Hub M12 ext. diag.
		15hex 21	0	Serial number	16 bytes		0hex
		16hex 22	0	Hardware Revision			
		17hex 23	0	Firmware Revision			
	18hex 24	0	Application Specific Tag	32 bytes	Read / Write	0hex	

Parameter Data/
Demand Data

	DPP	SPDU		Parameter	Data width	Access rights	Default Value
	Index	Index	Subindex				
Parameter data		40hex 64	0 1-32	Inversion of the inputs	4 bytes	Read / Write	0hex
		41hex 65	0 1-16	Config. inputs/outputs	2 bytes	Read / Write	0hex
		42hex 66	0 1-16	Safe state Pin 4	4 bytes	Read / Write	0hex
		43hex 67	0 1-16	Safe state Pin 2	4 bytes	Read / Write	0hex
		44hex 68	0 1-32	Voltage monitoring	4 bytes	Read	-
		45hex 69	0 1-32	Output monitoring	4 bytes	Read	-
		46hex 70	0 1-32	Actuator warning	4 bytes	Read	-
		54hex 84	0	Serial number	16 bytes	Read / Write	16x00hex
		55hex 85	0	Extension port	1 byte	Read / Write	1hex
		60hex 96	0 1-32	Identification	4 bytes	Read / Write	0hex

8 Configuration: BNI IOL-311-S02-K006-C01 extended with BNI IOL-311-S02-K006-C01

Device Access Locks 0Ch_{hex}

The parameter Device Access Locks allows control of the Device behavior. Only Data Storage standardized device functions can be configured via the defined flag in this parameter. The Device Access Locks configuration can be changed by overwriting the parameter. The actual configuration setting is available per read access to this parameter. Access is only permitted via Subindex 0.

Inversion of the inputs 40h_{hex}

Byte	0								1							
Bit	7	6	5	4	3	2	1	0	7	6	5	4	3	2	1	0
Sub-index	8	7	6	5	4	3	2	1	16	15	14	13	12	11	10	9
Description	* Inversion Port 7 Pin 4	Inversion Port 6 Pin 4	Inversion Port 5 Pin 4	Inversion Port 4 Pin 4	Inversion Port 3 Pin 4	Inversion Port 2 Pin 4	Inversion Port 1 Pin 4	Inversion Port 0 Pin 4	* Inversion Port 7 Pin 2	Inversion Port 6 Pin 2	Inversion Port 5 Pin 2	Inversion Port 4 Pin 2	Inversion Port 3 Pin 2	Inversion Port 2 Pin 2	Inversion Port 1 Pin 2	Inversion Port 0 Pin 2

* No function

Byte	2								3							
Bit	7	6	5	4	3	2	1	0	7	6	5	4	3	2	1	0
Sub-index	24	23	22	21	20	19	18	17	32	31	30	29	28	27	26	25
	Extension port															
Description	Inversion Port 7 Pin 4	Inversion Port 6 Pin 4	Inversion Port 5 Pin 4	Inversion Port 4 Pin 4	Inversion Port 3 Pin 4	Inversion Port 2 Pin 4	Inversion Port 1 Pin 4	Inversion Port 0 Pin 4	Inversion Port 7 Pin 2	Inversion Port 6 Pin 2	Inversion Port 5 Pin 2	Inversion Port 4 Pin 2	Inversion Port 3 Pin 2	Inversion Port 2 Pin 2	Inversion Port 1 Pin 2	Inversion Port 0 Pin 2

Inversion of port (x):
 0 – Normal
 1 - Inverted

8 Configuration: BNI IOL-311-S02-K006-C01 extended with BNI IOL-311-S02-K006-C01

Configuration of inputs/ outputs 41hex

Byte	0							
Bit	7	6	5	4	3	2	1	0
Sub-index	8	7	6	5	4	3	2	1
Description	* Direction Port 7	Direction Port 6	Direction Port 5	Direction Port 4	Direction Port 3	Direction Port 2	Direction Port 1	Direction Port 0

* No function

Byte	1							
Bit	7	6	5	4	3	2	1	0
Sub-index	16	15	14	13	12	11	10	9
Extension port								
Description	Direction Port 7	Direction Port 6	Direction Port 5	Direction Port 4	Direction Port 3	Direction Port 2	Direction Port 1	Direction Port 0

Direction of port (x):

- 0 - Input
- 1 - Output

8 Configuration: BNI IOL-311-S02-K006-C01 extended with BNI IOL-311-S02-K006-C01

Safe state of the outputs
42hex

The safe state parameter makes it possible to configure the outputs in case of a fault. If no IO-Link communication is possible or the "valid flag" of the output process data has not been set by the master, then each output adopts the configured status. The following statuses can be configured for each pin.

Safe state of the outputs on Pin 4 42hex

Byte	0								1							
	7	6	5	4	3	2	1	0	7	6	5	4	3	2	1	0
Sub-index	4		3		2		1		8		7		6		5	
Description	Safe state Port 3 Pin 4		Safe state Port 2 Pin 4		Safe state Port 1 Pin 4		Safe state Port 0 Pin 4		* Safe state Port 7 Pin 4		Safe state Port 6 Pin 4		Safe state Port 5 Pin 4		Safe state Port 4 Pin 4	

* No function

Byte	2								3							
	7	6	5	4	3	2	1	0	7	6	5	4	3	2	1	0
Sub-index	12		11		10		9		16		15		14		13	
Extension port																
Description	Safe state Port 3 Pin 4		Safe state Port 2 Pin 4		Safe state Port 1 Pin 4		Safe state Port 0 Pin 4		Safe state Port 7 Pin 4		Safe state Port 6 Pin 4		Safe state Port 5 Pin 4		Safe state Port 4 Pin 4	

8 Configuration: BNI IOL-311-S02-K006-C01 extended with BNI IOL-311-S02-K006-C01

Safe state of the outputs on Pin 2 43hex

Byte	0								1							
Bit	7	6	5	4	3	2	1	0	7	6	5	4	3	2	1	0
Sub-index	4		3		2		1		8		7		6		5	
Description	Safe state Port 3 Pin 2		Safe state Port 2 Pin 2		Safe state Port 1 Pin 2		Safe state Port 0 Pin 2		* Safe state Port 7 Pin 2		Safe state Port 6 Pin 2		Safe state Port 5 Pin 2		Safe state Port 4 Pin 2	

* No function

Byte	2								3							
Bit	7	6	5	4	3	2	1	0	7	6	5	4	3	2	1	0
Sub-index	12		11		10		9		16		15		14		13	
Extension port																
Description	Safe state Port 3 Pin 2		Safe state Port 2 Pin 2		Safe state Port 1 Pin 2		Safe state Port 0 Pin 2		Safe state Port 7 Pin 2		Safe state Port 6 Pin 2		Safe state Port 5 Pin 2		Safe state Port 4 Pin 2	

Value		Output state
bin	dec	
00	0	Output is 0V
01	1	Output is 24V
10	2	Current status is maintained
11	3	Not permitted

8 Configuration: BNI IOL-311-S02-K006-C01 extended with BNI IOL-311-S02-K006-C01

Voltage monitoring
44hex

Byte	0								1							
Bit	7	6	5	4	3	2	1	0	7	6	5	4	3	2	1	0
Sub-index	8	7	6	5	4	3	2	1					12	11		9
Description	Short-circuit Port 7 Pin 1	Short-circuit Port 6 Pin 1	Short-circuit Port 5 Pin 1	Short-circuit Port 4 Pin 1	Short-circuit Port 3 Pin 1	Short-circuit Port 2 Pin 1	Short-circuit Port 1 Pin 1	Short-circuit Port 0 Pin 1	-	-	-	-	Outputs off (UA too low)	Undervoltage UA	-	Undervoltage US

Byte	2								3							
Bit	7	6	5	4	3	2	1	0	7	6	5	4	3	2	1	0
Sub-index	24	23	22	21	20	19	18	17	32	31	30	29	28	27	26	25
	Extension port															
Description	Short-circuit Port 7 Pin 1	Short-circuit Port 6 Pin 1	Short-circuit Port 5 Pin 1	Short-circuit Port 4 Pin 1	Short-circuit Port 3 Pin 1	Short-circuit Port 2 Pin 1	Short-circuit Port 1 Pin 1	Short-circuit Port 0 Pin 1	-	-	-	-	Outputs off (UA too low)	Undervoltage UA	-	Undervoltage US

Output monitoring
45hex

Byte	0								1							
Bit	7	6	5	4	3	2	1	0	7	6	5	4	3	2	1	0
Sub-index	8	7	6	5	4	3	2	1	16	15	14	13	12	11	10	9
Description	* Short-circuit Port 7 Pin 4	Short-circuit Port 6 Pin 4	Short-circuit Port 5 Pin 4	Short-circuit Port 4 Pin 4	Short-circuit Port 3 Pin 4	Short-circuit Port 2 Pin 4	Short-circuit Port 1 Pin 4	Short-circuit Port 0 Pin 4	* Short-circuit Port 7 Pin 2	Short-circuit Port 6 Pin 2	Short-circuit Port 5 Pin 2	Short-circuit Port 4 Pin 2	Short-circuit Port 3 Pin 2	Short-circuit Port 2 Pin 2	Short-circuit Port 1 Pin 2	Short-circuit Port 0 Pin 2

* No function

8 Configuration: BNI IOL-311-S02-K006-C01 extended with BNI IOL-311-S02-K006-C01

Byte	2								3							
Bit	7	6	5	4	3	2	1	0	7	6	5	4	3	2	1	0
Sub-index	24	23	22	21	20	19	18	17	32	31	30	29	28	27	26	25
	Extension port															
Description	Short-circuit Port 7 Pin 4	Short-circuit Port 6 Pin 4	Short-circuit Port 5 Pin 4	Short-circuit Port 4 Pin 4	Short-circuit Port 3 Pin 4	Short-circuit Port 2 Pin 4	Short-circuit Port 1 Pin 4	Short-circuit Port 0 Pin 4	Short-circuit Port 7 Pin 2	Short-circuit Port 6 Pin 2	Short-circuit Port 5 Pin 2	Short-circuit Port 4 Pin 2	Short-circuit Port 3 Pin 2	Short-circuit Port 2 Pin 2	Short-circuit Port 1 Pin 2	Short-circuit Port 0 Pin 2

Actuator warning 46hex

Byte	0								1							
Bit	7	6	5	4	3	2	1	0	7	6	5	4	3	2	1	0
Sub-index	8	7	6	5	4	3	2	1	16	15	14	13	12	11	10	9
Description	* Warning Port 7 Pin 4	Warning Port 6 Pin 4	Warning Port 5 Pin 4	Warning Port 4 Pin 4	Warning Port 3 Pin 4	Warning Port 2 Pin 4	Warning Port 1 Pin 4	Warning Port 0 Pin 4	* Warning Port 7 Pin 2	Warning Port 6 Pin 2	Warning Port 5 Pin 2	Warning Port 4 Pin 2	Warning Port 3 Pin 2	Warning Port 2 Pin 2	Warning Port 1 Pin 2	Warning Port 0 Pin 2

* No function

Byte	2								3							
Bit	7	6	5	4	3	2	1	0	7	6	5	4	3	2	1	0
Sub-index	24	23	22	21	20	19	18	17	32	31	30	29	28	27	26	25
	Extension port															
Description	Warning Port 7 Pin 4	Warning Port 6 Pin 4	Warning Port 5 Pin 4	Warning Port 4 Pin 4	Warning Port 3 Pin 4	Warning Port 2 Pin 4	Warning Port 1 Pin 4	Warning Port 0 Pin 4	Warning Port 7 Pin 2	Warning Port 6 Pin 2	Warning Port 5 Pin 2	Warning Port 4 Pin 2	Warning Port 3 Pin 2	Warning Port 2 Pin 2	Warning Port 1 Pin 2	Warning Port 0 Pin 2

8 Configuration: BNI IOL-311-S02-K006-C01 extended with BNI IOL-311-S02-K006-C01

Setting the serial number 54_{hex}

The serial number has a default value of 16x00_{hex}.
 In order to use the "Identity" master validation mode, a serial number can be set using this parameter.
 This prevents a device from connecting to the wrong master port.

Configuration of the extension port 55_{hex}

Configuration	Index 55 _{hex} value
BNI IOL-311-S02-K006-C01	0
BNI IOL-311-S02-K006-C01 with BNI IOL-311-S02-K006-C01	1
BNI IOL-311-S02-K006-C01 with BNI IOL-751-V08-K007	2
BNI IOL-311-S02-K006-C01 with BNI IOL-751-V10-K007	3
BNI IOL-311-S02-K006-C01 with BNI IOL-751-V13-K007	4

Note
 The "Factory reset" command does not affect the configuration of the extension port in any way.

Identification 60_{hex}

Byte	0								1							
	7	6	5	4	3	2	1	0	7	6	5	4	3	2	1	0
Description	Identification Byte0								Identification Byte1							

Byte	2								3							
	7	6	5	4	3	2	1	0	7	6	5	4	3	2	1	0
	Extension port															
Description	Identification Byte0								Identification Byte1							

9 Configuration: BNI IOL-311-S02-K006-C01 extended with Valve Terminal Connector with 22/24 Valves



9.1. IO-Link Data

BNI IOL-311-S02-K006-C01 extended with valve terminal connector with 22/24 valves	
Transfer rate	COM2 (38.4 kbaud)
Minimum cycle time	7.2 ms
Process data length	10 byte input, 6 byte output

9.2. Process Data/
Input Data

Process data length of 10 bytes:

Byte	0								1							
Bit	7	6	5	4	3	2	1	0	7	6	5	4	3	2	1	0
Description	-	Input Port 6 Pin 4	Input Port 5 Pin 4	Input Port 4 Pin 4	Input Port 3 Pin 4	Input Port 2 Pin 4	Input Port 1 Pin 4	Input Port 0 Pin 4	-	Input Port 6 Pin 2	Input Port 5 Pin 2	Input Port 4 Pin 2	Input Port 3 Pin 2	Input Port 2 Pin 2	Input Port 1 Pin 2	Input Port 0 Pin 2

Byte	2								3							
Bit	7	6	5	4	3	2	1	0	7	6	5	4	3	2	1	0
Description	Short-circuit Port 7 Pin 1	Short-circuit Port 6 Pin 1	Short-circuit Port 5 Pin 1	Short-circuit Port 4 Pin 1	Short-circuit Port 3 Pin 1	Short-circuit Port 2 Pin 1	Short-circuit Port 1 Pin 1	Short-circuit Port 0 Pin 1	-	-	-	-	Outputs off (UA too low)	Undervoltage UA	-	Undervoltage US

9 Configuration: BNI IOL-311-S02-K006-C01 extended with Valve Terminal Connector with 22/24 Valves

Byte	4								5							
Bit	7	6	5	4	3	2	1	0	7	6	5	4	3	2	1	0
Description	* Short-circuit Port 7 Pin 4	Short-circuit Port 6 Pin 4	Short-circuit Port 5 Pin 4	Short-circuit Port 4 Pin 4	Short-circuit Port 3 Pin 4	Short-circuit Port 2 Pin 4	Short-circuit Port 1 Pin 4	Short-circuit Port 0 Pin 4	* Short-circuit Port 7 Pin 2	Short-circuit Port 6 Pin 2	Short-circuit Port 5 Pin 2	Short-circuit Port 4 Pin 2	Short-circuit Port 3 Pin 2	Short-circuit Port 2 Pin 2	Short-circuit Port 1 Pin 2	Short-circuit Port 0 Pin 2

Byte	6								7							
Bit	7	6	5	4	3	2	1	0	7	6	5	4	3	2	1	0
Description	* Warning Port 7 Pin 4	Warning Port 6 Pin 4	Warning Port 5 Pin 4	Warning Port 4 Pin 4	Warning Port 3 Pin 4	Warning Port 2 Pin 4	Warning Port 1 Pin 4	Warning Port 0 Pin 4	* Warning Port 7 Pin 2	Warning Port 6 Pin 2	Warning Port 5 Pin 2	Warning Port 4 Pin 2	Warning Port 3 Pin 2	Warning Port 2 Pin 2	Warning Port 1 Pin 2	Warning Port 0 Pin 2

* No function

Byte	8								9							
Bit	7	6	5	4	3	2	1	0	7	6	5	4	3	2	1	0
Description	Identification Byte0								Identification Byte1							

9.3. Process Data / Output Data

Process data length of 6 bytes

Byte	0								1							
Bit	7	6	5	4	3	2	1	0	7	6	5	4	3	2	1	0
Description	-	Output Port 6 Pin 4	Output Port 5 Pin 4	Output Port 4 Pin 4	Output Port 3 Pin 4	Output Port 2 Pin 4	Output Port 1 Pin 4	Output Port 0 Pin 4	-	Output Port 6 Pin 2	Output Port 5 Pin 2	Output Port 4 Pin 2	Output Port 3 Pin 2	Output Port 2 Pin 2	Output Port 1 Pin 2	Output Port 0 Pin 2

9 Configuration: BNI IOL-311-S02-K006-C01 extended with Valve Terminal Connector with 22/24 Valves

Byte	2								3							
Bit	7	6	5	4	3	2	1	0	7	6	5	4	3	2	1	0
	Valve terminal on the Extension port															
Description	* Valve 12 – Coil A	Valve 11 – Coil A	Valve 10 – Coil A	Valve 09 – Coil A	Valve 08 – Coil A	Valve 07 – Coil A	Valve 06 – Coil A	Valve 05 – Coil A	Valve 04 – Coil A	Valve 03 – Coil A	Valve 02 – Coil A	Valve 01 – Coil A

* No function for V013

Byte	4								5							
Bit	7	6	5	4	3	2	1	0	7	6	5	4	3	2	1	0
	Valve terminal on the Extension port															
Description	* Valve 12 – Coil B	Valve 11 – Coil B	Valve 10 – Coil B	Valve 09 – Coil B	Valve 08 – Coil B	Valve 07 – Coil B	Valve 06 – Coil B	Valve 05 – Coil B	Valve 04 – Coil B	Valve 03 – Coil B	Valve 02 – Coil B	Valve 01 – Coil B

* No function for V013

9 Configuration: BNI IOL-311-S02-K006-C01 extended with Valve Terminal Connector with 22/24 Valves

9.4. Parameter Data / Demand Data

	DPP	SPDU		Parameter	Data width	Access rights	Default value
	Index	Index	Sub-index				
Identification data	07hex			Vendor ID	2 bytes	Read only	0378hex
	08hex						
	09hex			Device ID	3 bytes		0x05 0B E2 0x05 0B E3 0x05 0B E4
	0Ahex						
	0Bhex						
		0Chex 12	0	Device Access Locks	2 bytes	Read/Write	0hex
		10hex 16	0	Vendor Name	7 bytes	Read only	BALLUFF
		11hex 17	0	Vendor text	15 bytes		www.balluff.com
		12hex 18	0	Product name			BNI IOL-311-S02-K006-C01 with BNI IOL-751-V08-K007 BNI IOL-311-S02-K006-C01 with BNI IOL-751-V10-K007 BNI IOL-311-S02-K006-C01 with BNI IOL-751-V13-K007
		13hex 19	0	Product ID	7 bytes		BNI00AW with BNI006N BNI00AW with BNI006P BNI00AW with BNI006R
		14hex 20	0	Product text			Sensor/Actor NPN Hub M12 ext. diag. with BNI IOL-751-V08-K007 Sensor/Actor NPN Hub M12 ext. diag. with BNI IOL-751-V10-K007 Sensor/Actor NPN Hub M12 ext. diag. with BNI IOL-751-V13-K007
		15hex 21	0	Serial number	16 bytes		0hex
		16hex 22	0	Hardware Revision			
	17hex 23	0	Firmware Revision				
	18hex 24	0	Application Specific Tag	32 bytes	Read / Write	0hex	

	DPP	SPDU		Parameter	Data width	Access rights	Default Value
	Index	Index	Subindex				
Parameter data		40hex 64	0 1-16	Inversion of the inputs	2 bytes	Read / Write	0hex
		41hex 65	0 1-8	Config. inputs/outputs	1 byte	Read / Write	0hex
		42hex 66	0 1-32	Safe state on Pin 4	10 bytes	Read / Write	0hex
		43hex 67	0 1-8	Safe state on Pin 2	2 bytes	Read / Write	0hex
		44hex 68	0 1-23	Voltage monitoring	3 bytes	Read	-
		45hex 69	0 1-40	Output monitoring	6 bytes	Read	-
		46hex 70	0 1-16	Actuator warning	2 bytes	Read	-
		54hex 84	0	Serial number	16 bytes	Read / Write	16x00hex
		55hex 85	0	Extension port	1 byte	Read / Write	2, 3, 4hex
		60hex 96	0 1-16	Identification	2 bytes	Read / Write	0hex

9 Configuration: BNI IOL-311-S02-K006-C01 extended with Valve Terminal Connector with 22/24 Valves

Device Access Locks 0C_{hex}

The parameter Device Access Locks allows control of the Device behavior. Only Data Storage standardized device functions can be configured via the defined flag in this parameter. The Device Access Locks configuration can be changed by overwriting the parameter. The actual configuration setting is available per read access to this parameter. Access is only permitted via Subindex 0.

Inversion of the inputs 40_{hex}

Byte	0								1							
Bit	7	6	5	4	3	2	1	0	7	6	5	4	3	2	1	0
Sub-index	8	7	6	5	4	3	2	1	16	15	14	13	12	11	10	9
Description	* Inversion Port 7 Pin 4	Inversion Port 6 Pin 4	Inversion Port 5 Pin 4	Inversion Port 4 Pin 4	Inversion Port 3 Pin 4	Inversion Port 2 Pin 4	Inversion Port 1 Pin 4	Inversion Port 0 Pin 4	* Inversion Port 7 Pin 2	Inversion Port 6 Pin 2	Inversion Port 5 Pin 2	Inversion Port 4 Pin 2	Inversion Port 3 Pin 2	Inversion Port 2 Pin 2	Inversion Port 1 Pin 2	Inversion Port 0 Pin 2

* No function

Inversion of port (x):

0 - Normal
1 - Inverted

Configuration of inputs/ outputs 41_{hex}

Byte	0							
Bit	7	6	5	4	3	2	1	0
Sub-index	8	7	6	5	4	3	2	1
Description	* Direction Port 7	Direction Port 6	Direction Port 5	Direction Port 4	Direction Port 3	Direction Port 2	Direction Port 1	Direction Port 0

* No function

Direction of port (x):

0 - Input
1 - Output

9 Configuration: BNI IOL-311-S02-K006-C01 extended with Valve Terminal Connector with 22/24 Valves

Safe state of the outputs
42hex

The safe state parameter makes it possible to configure the outputs in case of a fault. If no IO-Link communication is possible or the "valid flag" of the output process data has not been set by the master, then each output adopts the configured status. The following statuses can be configured for each pin.

Safe state of the outputs Pin 4
42hex

Byte	0								1							
	7	6	5	4	3	2	1	0	7	6	5	4	3	2	1	0
Sub-index	4		3		2		1		8		7		6		5	
Description	Safe state Port 3 Pin 4		Safe state Port 2 Pin 4		Safe state Port 1 Pin 4		Safe state Port 0 Pin 4		* Safe state Port 7 Pin 4		Safe state Port 6 Pin 4		Safe state Port 5 Pin 4		Safe state Port 4 Pin 4	

* No function

Byte	2								3							
	7	6	5	4	3	2	1	0	7	6	5	4	3	2	1	0
Sub-index									31		29		27		25	
Valve terminal on the extension port																
Description		* Valve 12 – Coil A		Valve 11 – Coil A		Valve 10 – Coil A		Valve 09 – Coil A	

* No function for V013

Byte	4								5							
	7	6	5	4	3	2	1	0	7	6	5	4	3	2	1	0
Sub-index	23		21		19		17		15		13		11		9	
Valve terminal on the extension port																
Description	Valve 08 – Coil A		Valve 07 – Coil A		Valve 06 – Coil A		Valve 05 – Coil A		Valve 04 – Coil A		Valve 03 – Coil A		Valve 02 – Coil A		Valve 01 – Coil A	

9 Configuration: BNI IOL-311-S02-K006-C01 extended with Valve Terminal Connector with 22/24 Valves

Byte	6								7							
Bit	7	6	5	4	3	2	1	0	7	6	5	4	3	2	1	0
Sub-index									32		30		28		26	
	Valve terminal on the extension port															
Description									* Valve 12 – Coil B		Valve 11 – Coil B		Valve 10 – Coil B		Valve 09 – Coil B	

* No function for V013

Byte	8								9							
Bit	7	6	5	4	3	2	1	0	7	6	5	4	3	2	1	0
Sub-index	24		22		20		18		16		14		12		10	
	Valve terminal on the extension port															
Description	Valve 08 – Coil B		Valve 07 – Coil B		Valve 06 – Coil B		Valve 05 – Coil B		Valve 04 – Coil B		Valve 03 – Coil B		Valve 02 – Coil B		Valve 01 – Coil B	

Safe state of the outputs on Pin 2 43hex

Byte	0								1							
Bit	7	6	5	4	3	2	1	0	7	6	5	4	3	2	1	0
Sub-index	4		3		2		1		8		7		6		5	
Description	Safe state Port 3 Pin 2		Safe state Port 2 Pin 2		Safe state Port 1 Pin 2		Safe state Port 0 Pin 2		* Safe state Port 7 Pin 2		Safe state Port 6 Pin 2		Safe state Port 5 Pin 2		Safe state Port 4 Pin 2	

* No function

Value		Output state
bin	dec	
00	0	Output is 0V
01	1	Output is 24V
10	2	Current status is maintained
11	3	Not defined

9 Configuration: BNI IOL-311-S02-K006-C01 extended with Valve Terminal Connector with 22/24 Valves

Voltage monitoring
44hex

Byte	0								1							
Bit	7	6	5	4	3	2	1	0	7	6	5	4	3	2	1	0
Sub-index	8	7	6	5	4	3	2	1					12	11		9
Description	Short-circuit Port 7 Pin 1	Short-circuit Port 6 Pin 1	Short-circuit Port 5 Pin 1	Short-circuit Port 4 Pin 1	Short-circuit Port 3 Pin 1	Short-circuit Port 2 Pin 1	Short-circuit Port 1 Pin 1	Short-circuit Port 0 Pin 1	-	-	-	-	Outputs off (UA too low)	Undervoltage UA	-	Undervoltage US

Byte	2							
Bit	7	6	5	4	3	2	1	0
Sub-index		23				19		17
Valve terminal on the extension port								
Description	-	Overload UA	-	-	-	Undervoltage UA	-	Undervoltage US

9 Configuration: BNI IOL-311-S02-K006-C01 extended with Valve Terminal Connector with 22/24 Valves

Output monitoring
45hex

Byte	0								1							
Bit	7	6	5	4	3	2	1	0	7	6	5	4	3	2	1	0
Sub-index	8	7	6	5	4	3	2	1	16	15	14	13	12	11	10	9
Description	* Short-circuit Port 7 Pin 4	Short-circuit Port 6 Pin 4	Short-circuit Port 5 Pin 4	Short-circuit Port 4 Pin 4	Short-circuit Port 3 Pin 4	Short-circuit Port 2 Pin 4	Short-circuit Port 1 Pin 4	Short-circuit Port 0 Pin 4	* Short-circuit Port 7 Pin 2	Short-circuit Port 6 Pin 2	Short-circuit Port 5 Pin 2	Short-circuit Port 4 Pin 2	Short-circuit Port 3 Pin 2	Short-circuit Port 2 Pin 2	Short-circuit Port 1 Pin 2	Short-circuit Port 0 Pin 2

* No function

Byte	2								3							
Bit	7	6	5	4	3	2	1	0	7	6	5	4	3	2	1	0
Sub-index					39	37	35	33	31	29	27	25	23	21	19	17
Valve terminal on the extension port																
Description	-	-	-	-	* Valve 12 – Coil A	Valve 11 – Coil A	Valve 10 – Coil A	Valve 09 – Coil A	Valve 08 – Coil A	Valve 07 – Coil A	Valve 06 – Coil A	Valve 05 – Coil A	Valve 04 – Coil A	Valve 03 – Coil A	Valve 02 – Coil A	Valve 01 – Coil A

* No function for V013

Byte	4								5							
Bit	7	6	5	4	3	2	1	0	7	6	5	4	3	2	1	0
Sub-index					40	38	36	34	32	30	28	26	24	22	20	18
Valve terminal on the extension port																
Description	-	-	-	-	* Valve 12 – Coil B	Valve 11 – Coil B	Valve 10 – Coil B	Valve 09 – Coil B	Valve 08 – Coil B	Valve 07 – Coil B	Valve 06 – Coil B	Valve 05 – Coil B	Valve 04 – Coil B	Valve 03 – Coil B	Valve 02 – Coil B	Valve 01 – Coil B

* No function for V013

9 Configuration: BNI IOL-311-S02-K006-C01 extended with Valve Terminal Connector with 22/24 Valves

Actuator warning
46hex

Byte	0								1							
Bit	7	6	5	4	3	2	1	0	7	6	5	4	3	2	1	0
Sub-index	8	7	6	5	4	3	2	1	16	15	14	13	12	11	10	9
Description	* Warning Port 7 Pin 4	Warning Port 6 Pin 4	Warning Port 5 Pin 4	Warning Port 4 Pin 4	Warning Port 3 Pin 4	Warning Port 2 Pin 4	Warning Port 1 Pin 4	Warning Port 0 Pin 4	* Warning Port 7 Pin 2	Warning Port 6 Pin 2	Warning Port 5 Pin 2	Warning Port 4 Pin 2	Warning Port 3 Pin 2	Warning Port 2 Pin 2	Warning Port 1 Pin 2	Warning Port 0 Pin 2

* No function

Setting the serial number
54hex

The serial number has a default value of 16x00hex. In order to use the "Identity" master validation mode, a serial number can be set using this parameter. This prevents a device from connecting to the wrong master port.

Configuration of the extension port
55hex

Configuration	Index 55hex value
BNI IOL-311-S02-K006-C01	0
BNI IOL-311-S02-K006-C01 with BNI IOL-311-S02-K006-C01	1
BNI IOL-311-S02-K006-C01 with BNI IOL-751-V08-K007	2
BNI IOL-311-S02-K006-C01 with BNI IOL-751-V10-K007	3
BNI IOL-311-S02-K006-C01 with BNI IOL-751-V13-K007	4



Note

The "Factory reset" command does not affect the configuration of the extension port in any way.

Identification
60hex

Byte	0								1							
Bit	7	6	5	4	3	2	1	0	7	6	5	4	3	2	1	0
Description	Identification Byte0								Identification Byte1							

10 Error Codes and Events

10.1. Error Codes/
Errors

Error code	Description
0x8011	Index not available
0x8012	Subindex not available
0x8023	Access denied
0x8033	Parameter length overrun
0x8034	Parameter length underrun
0x8035	Function not available
0x8036	Function temporarily unavailable

10.2. Events

IO-Link Revision 1.0	
Event code	Description
0x5112	Low sensor voltage (US)
0x5114	Low actuator voltage (UA)
0x5410	Output stages
0x8DF0	Retry at the extension port
0x8DF1	Device lost at the extension port
0x8DF2	Wrong device at the extension port
IO-Link Revision 1.1	
Event code	Description
0x5111	Low sensor voltage (US)
0x5112	Low actuator voltage (UA)
0x7710	Short circuit
0x8DF0	Retry at the extension port
0x8DF1	Device lost at the extension port
0x8DF2	Wrong device at the extension port

11 IO-Link Functions

11.1. IO-Link Version 1.0/ 1.1

This device can be operated with an IO-Link master according to IO-Link version 1.0, and version 1.1. Version-specific functions such as data storage (version 1.1) are only supported in combination with a suitable IO-Link master.

11.2. Data Storage

Each IO-Link master of IO-Link version 1.1 features data storage in which an image of the IO-Link device configuration can be stored. When a device is replaced, the stored configuration is automatically transferred to the new device. This guarantees minimal downtime. Validation must be switched on in order to use the data storage. For information about the configuration of data storage and validation, please refer to the operating manual of the respective IO-Link master.

11.3. Block Configuration

The device supports block configuration. This allows all parameters in a data block to be consistently imported from a controller or a configuration tool into the device.

11.4. Restoring the Factory Settings

The factory settings on the device can be restored by carrying out the "restore factory settings" system command.
0x82 must be written to Index 2 Subindex 0 for the command.

12 Technical Data

12.1. Dimensions

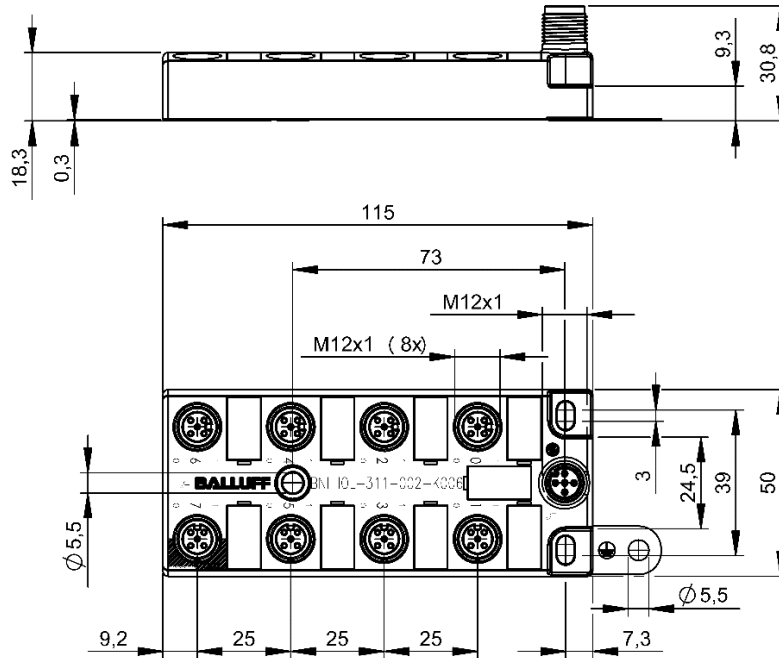

12.2. Mechanical Data

Housing material	Plastic, transparent
IO-Link port	IO-Link port M12, A-coded, male
NPN I/O ports	M12x1, A-coded, female (8 piece)
Weight	100 g
Dimension (L x W x H, without connector)	115 x 50 x 30.8 mm

12.3. Electrical Data

Supply voltage	18-30.2 V DC, corresponding to EN 61131-2
Ripple	< 1%
Current consumption without load	≤ 65 mA
Load current (PIN 1) – Input Port	Max. 350 mA (temperature-dependent)
Load current (PIN 1) – Output Port	Max. 1,5 A (temperature-dependent)
Load current per output (PIN 2.4)	Max. 200 mA (temperature-dependent)
Inputs	NPN, type 3

12.4. Operating conditions

Operating temperature	-5 °C ... +55 °C
Storage temperature	-25 °C ... +70 °C
Degree of protection	IP67 (only in plugged-in and screwed state)

13 Function Indicators

13.1. Function Indicators

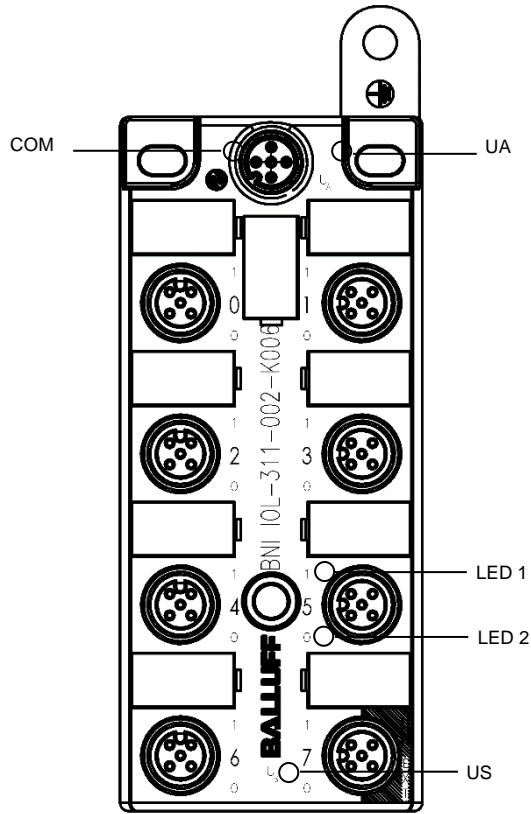

LED indicator module status

	Indicator	Function
IO-Link communication	Green	No communication
	Green, negatively pulsed	Communication OK
	Red	Communication overload
	Off	Module is without voltage
US LED	Green	Sensor power supply is OK
	Green, flashing quickly	Undervoltage < 18 V
	Off	Module is without voltage
UA LED	Green	Actuator power supply is OK
	Green, flashing quickly	Undervoltage < 18 V
	Off	No actuator power supply

13 Function Indicators

Digital LED indicators for inputs/outputs

LED 2, input/output on Pin 4 and LED 1, input/output on Pin 2

Indicator	Request / Signal
Yellow	Input/output signal = 1
Red	Sensor power supply short-circuit, actuator warning actuator short circuit
Off	Input/output signal = 0

Extension port

The table is valid if the extension port is active. If the extension port is used as a standard I/O, then the description from "Digital LED indicators for inputs/outputs" can be used.

Status	Function
Green	IO-Link – connection active
Green, flashing	No IO-Link connection or faulty IO-Link device
Quick, red flashing	Incorrect IO-Link device or incorrect configuration
Red	IO-Link short-circuit on Pin 4

14 Appendix

14.1. Type Code

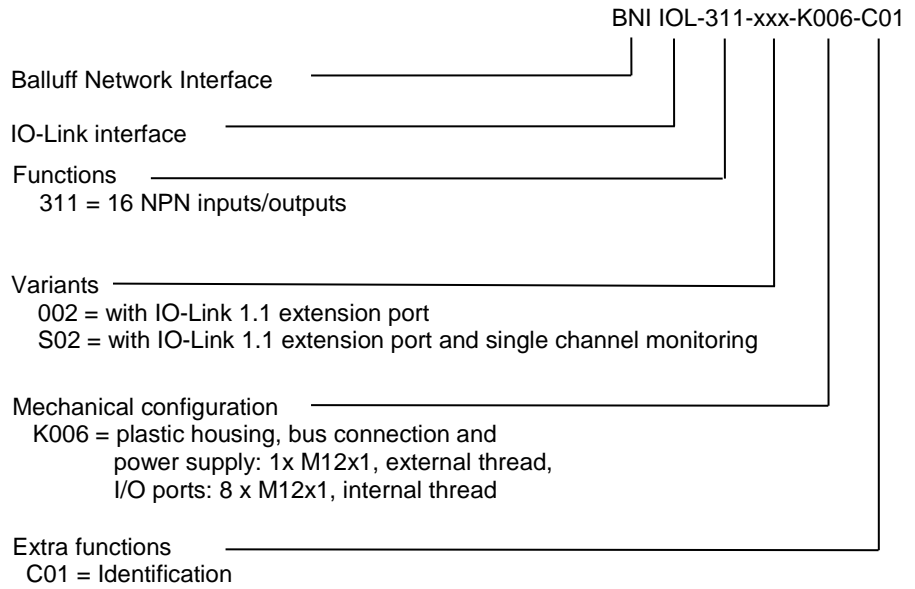

14.2. Ordering Information

Type code	Ordering code
BNI IOL-311-002-K006	BNI00AF
BNI IOL-311-S02-K006-C01	BNI00AW

Notes

www.balluff.com

Balluff GmbH
Schurwaldstrasse 9
73765 Neuhausen a.d.F.
Germany
Tel. +49 7158 173-0
Fax +49 7158 5010
balluff@balluff.de