



Terminator Installation and I/O Manual

Manual Number: T1K-INST-M

⚡ WARNING ⚡

Thank you for purchasing automation equipment from **AutomationDirect.com**[®], doing business as, **AutomationDirect**. We want your new automation equipment to operate safely. Anyone who installs or uses this equipment should read this publication (and any other relevant publications) before installing or operating the equipment.

To minimize the risk of potential safety problems, you should follow all applicable local and national codes that regulate the installation and operation of your equipment. These codes vary from area to area and usually change with time. It is your responsibility to determine which codes should be followed, and to verify that the equipment, installation, and operation is in compliance with the latest revision of these codes.

At a minimum, you should follow all applicable sections of the National Fire Code, National Electrical Code, and the codes of the National Electrical Manufacturer's Association (NEMA). There may be local regulatory or government offices that can also help determine which codes and standards are necessary for safe installation and operation.

Equipment damage or serious injury to personnel can result from the failure to follow all applicable codes and standards. We do not guarantee the products described in this publication are suitable for your particular application, nor do we assume any responsibility for your product design, installation, or operation.

Our products are not fault-tolerant and are not designed, manufactured or intended for use or resale as on-line control equipment in hazardous environments requiring fail-safe performance, such as in the operation of nuclear facilities, aircraft navigation or communication systems, air traffic control, direct life support machines, or weapons systems, in which the failure of the product could lead directly to death, personal injury, or severe physical or environmental damage ("High Risk Activities"). **AutomationDirect** specifically disclaims any expressed or implied warranty of fitness for High Risk Activities.

For additional warranty and safety information, see the Terms and Conditions section of our catalog. If you have any questions concerning the installation or operation of this equipment, or if you need additional information, please call us at 770-844-4200.

This publication is based on information that was available at the time it was printed. At **AutomationDirect** we constantly strive to improve our products and services, so we reserve the right to make changes to the products and/or publications at any time without notice and without any obligation. This publication may also discuss features that may not be available in certain revisions of the product.

Trademarks

This publication may contain references to products produced and/or offered by other companies. The product and company names may be trademarked and are the sole property of their respective owners. **AutomationDirect** disclaims any proprietary interest in the marks and names of others.

Copyright 2025 **AutomationDirect.com**[®] Incorporated
All Rights Reserved

No part of this manual shall be copied, reproduced, or transmitted in any way without the prior, written consent of **AutomationDirect.com**[®] Incorporated. **AutomationDirect** retains the exclusive rights to all information included in this document.

⚡ ADVERTENCIA ⚡

Gracias por comprar equipo de automatización de **Automationdirect.com**[®]. Deseamos que su nuevo equipo de automatización opere de manera segura. Cualquier persona que instale o use este equipo debe leer esta publicación (y cualquier otra publicación pertinente) antes de instalar u operar el equipo.

Para reducir al mínimo el riesgo debido a problemas de seguridad, debe seguir todos los códigos de seguridad locales o nacionales aplicables que regulan la instalación y operación de su equipo. Estos códigos varían de área en área y usualmente cambian con el tiempo. Es su responsabilidad determinar cuales códigos deben ser seguidos y verificar que el equipo, instalación y operación estén en cumplimiento con la revisión más reciente de estos códigos.

Como mínimo, debe seguir las secciones aplicables del Código Nacional de Incendio, Código Nacional Eléctrico, y los códigos de (NEMA) la Asociación Nacional de Fabricantes Eléctricos de USA. Puede haber oficinas de normas locales o del gobierno que pueden ayudar a determinar cuales códigos y normas son necesarios para una instalación y operación segura.

Si no se siguen todos los códigos y normas aplicables, puede resultar en daños al equipo o lesiones serias a personas. No garantizamos los productos descritos en esta publicación para ser adecuados para su aplicación en particular, ni asumimos ninguna responsabilidad por el diseño de su producto, la instalación u operación.

Nuestros productos no son tolerantes a fallas y no han sido diseñados, fabricados o intencionados para uso o reventa como equipo de control en línea en ambientes peligrosos que requieren una ejecución sin fallas, tales como operación en instalaciones nucleares, sistemas de navegación aérea, o de comunicación, control de tráfico aéreo, máquinas de soporte de vida o sistemas de armamentos en las cuales la falla del producto puede resultar directamente en muerte, heridas personales, o daños físicos o ambientales severos (“Actividades de Alto Riesgo”). **Automationdirect.com** específicamente rechaza cualquier garantía ya sea expresada o implicada para actividades de alto riesgo.

Para información adicional acerca de garantía e información de seguridad, vea la sección de Términos y Condiciones de nuestro catálogo. Si tiene alguna pregunta sobre instalación u operación de este equipo, o si necesita información adicional, por favor llámenos al número 770-844-4200 en Estados Unidos.

Esta publicación está basada en la información disponible al momento de impresión. En **Automationdirect.com** nos esforzamos constantemente para mejorar nuestros productos y servicios, así que nos reservamos el derecho de hacer cambios al producto y/o a las publicaciones en cualquier momento sin notificación y sin ninguna obligación. Esta publicación también puede discutir características que no estén disponibles en ciertas revisiones del producto.

Marcas Registradas

Esta publicación puede contener referencias a productos producidos y/u ofrecidos por otras compañías. Los nombres de las compañías y productos pueden tener marcas registradas y son propiedad única de sus respectivos dueños. **Automationdirect.com**, renuncia cualquier interés propietario en las marcas y nombres de otros.

PROPIEDAD LITERARIA 2025, **AUTOMATIONDIRECT.COM**[®] INCORPORATED
Todos los derechos reservados

No se permite copiar, reproducir, o transmitir de ninguna forma ninguna parte de este manual sin previo consentimiento por escrito de **Automationdirect.com**[®] Incorporated. **Automationdirect.com** retiene los derechos exclusivos a toda la información incluida en este documento. Los usuarios de este equipo pueden copiar este documento solamente para instalar, configurar y mantener el equipo correspondiente. También las instituciones de enseñanza pueden usar este manual para propósitos educativos.

⚡ AVERTISSEMENT ⚡

Nous vous remercions d'avoir acheté l'équipement d'automatisation de **Automationdirect.com**®, en faisant des affaires comme, **AutomationDirect**. Nous tenons à ce que votre nouvel équipement d'automatisation fonctionne en toute sécurité. Toute personne qui installe ou utilise cet équipement doit lire la présente publication (et toutes les autres publications pertinentes) avant de l'installer ou de l'utiliser.

Afin de réduire au minimum le risque d'éventuels problèmes de sécurité, vous devez respecter tous les codes locaux et nationaux applicables régissant l'installation et le fonctionnement de votre équipement. Ces codes diffèrent d'une région à l'autre et, habituellement, évoluent au fil du temps. Il vous incombe de déterminer les codes à respecter et de vous assurer que l'équipement, l'installation et le fonctionnement sont conformes aux exigences de la version la plus récente de ces codes.

Vous devez, à tout le moins, respecter toutes les sections applicables du Code national de prévention des incendies, du Code national de l'électricité et des codes de la National Electrical Manufacturer's Association (NEMA). Des organismes de réglementation ou des services gouvernementaux locaux peuvent également vous aider à déterminer les codes ainsi que les normes à respecter pour assurer une installation et un fonctionnement sûrs.

L'omission de respecter la totalité des codes et des normes applicables peut entraîner des dommages à l'équipement ou causer de graves blessures au personnel. Nous ne garantissons pas que les produits décrits dans cette publication conviennent à votre application particulière et nous n'assumons aucune responsabilité à l'égard de la conception, de l'installation ou du fonctionnement de votre produit.

Nos produits ne sont pas insensibles aux défaillances et ne sont ni conçus ni fabriqués pour l'utilisation ou la revente en tant qu'équipement de commande en ligne dans des environnements dangereux nécessitant une sécurité absolue, par exemple, l'exploitation d'installations nucléaires, les systèmes de navigation aérienne ou de communication, le contrôle de la circulation aérienne, les équipements de survie ou les systèmes d'armes, pour lesquels la défaillance du produit peut provoquer la mort, des blessures corporelles ou de graves dommages matériels ou environnementaux («activités à risque élevé»). La société **AutomationDirect** nie toute garantie expresse ou implicite d'aptitude à l'emploi en ce qui a trait aux activités à risque élevé.

Pour des renseignements additionnels touchant la garantie et la sécurité, veuillez consulter la section Modalités et conditions de notre documentation. Si vous avez des questions au sujet de l'installation ou du fonctionnement de cet équipement, ou encore si vous avez besoin de renseignements supplémentaires, n'hésitez pas à nous téléphoner au 770-844-4200.

Cette publication s'appuie sur l'information qui était disponible au moment de l'impression. À la société **AutomationDirect**, nous nous efforçons constamment d'améliorer nos produits et services. C'est pourquoi nous nous réservons le droit d'apporter des modifications aux produits ou aux publications en tout temps, sans préavis ni quelque obligation que ce soit. La présente publication peut aussi porter sur des caractéristiques susceptibles de ne pas être offertes dans certaines versions révisées du produit.

Marques de commerce

La présente publication peut contenir des références à des produits fabriqués ou offerts par d'autres entreprises. Les désignations des produits et des entreprises peuvent être des marques de commerce et appartiennent exclusivement à leurs propriétaires respectifs. **AutomationDirect** nie tout intérêt dans les autres marques et désignations.

Copyright 2025, **Automationdirect.com**® Incorporated
Tous droits réservés

Nulle partie de ce manuel ne doit être copiée, reproduite ou transmise de quelque façon que ce soit sans le consentement préalable écrit de la société **Automationdirect.com**® Incorporated. **AutomationDirect** conserve les droits exclusifs à l'égard de tous les renseignements contenus dans le présent document.

TERMINATOR INSTALLATION AND I/O MANUAL



Please include the Manual Number and the Manual Issue, both shown below, when communicating with Technical Support regarding this publication.

Manual Number: T1K-INST-M
Issue: 3rd Edition, Rev. E
Issue Date: 08/25

Edition/Rev	Date	Publication History
First Edition	11/00	Original issue
Rev. A	02/01	Added new module and minor corrections
Rev. B	07/01	Added new modules
Rev. C	04/02	Added new modules and minor corrections
Rev. D	12/02	Added new module and general updates
Rev. E	04/03	Added new module and added Class 1, Division 2, Zone 2 Approval
2nd Edition	09/03	Added new module and minor corrections
Rev. A	09/04	Added new modules and minor corrections
3rd Edition	05/13	Converted manual from Interleaf to QuarkXpress and made minor corrections
Rev. A	10/16	Added T1F-16TMST thermistor input module
Rev. B	01/18	Added Module Control Byte examples (4-21 to 4-24). General updates.
Rev. C	08/20	T1H-PBC discontinued, added notes to Chapter 3 accordingly.
Rev. D	11/24	Removed Type 1 fonts, inserted hyperlink on footers
Rev. E	08/25	Retired T1F-16TMST thermistor input module

TABLE OF CONTENTS



Chapter 1 - Getting Started

About This Manual	1-10
The Purpose of this Manual.....	1-10
Supplemental Manuals.....	1-10
Technical Support.....	1-10
Conventions Used	1-11
Key Topics for Each Chapter.....	1-11
Terminator I/O Base Controllers	1-12
Terminator I/O System Components	1-13
Power Supplies.....	1-13
I/O Modules.....	1-13

Chapter 2 - Installation and Wiring

Safety Guidelines	2-15
Plan for Safety.....	2-15
Three Levels of Protection.....	2-16
Emergency Stops.....	2-16
Emergency Power Disconnect.....	2-17
Orderly System Shutdown.....	2-17
Class 1, Division 2, Zone 2 Approval.....	2-17
Mounting Guidelines	2-18
Dimensions.....	2-18
Panel Mounting and Layout.....	2-19
Enclosures.....	2-20
Environmental Specifications.....	2-21
Power.....	2-21
Agency Approvals.....	2-21

Assembling the Components	2-22
Assembling the I/O Modules and Bases	2-22
Mounting the Components on DIN Rail.....	2-22
Connecting the Components on the DIN Rail	2-23
Removing I/O Modules from the Base	2-23
Multiple Power Supplies / Local Expansion Configurations	2-24
Multiple Power Supply Configuration.....	2-24
Example Using T1K-10CBL and T1K-10CBL-1 Expansion Cables	2-24
Example Using T1K-05CBL-RR-1 and T1K-05CBL-LL Expansion Cables	2-25
Example Using T1K-10CBL and T1K-05CBL-RR-1 Expansion Cables.....	2-26
Example Using T1K-05CBL-RR-1 Expansion Cables	2-27
Power Supply Wiring Guidelines	2-28
Power Wiring.....	2-28

Chapter 3 - I/O Wiring and Specifications

I/O Wiring Strategies	3-3
Terminator I/O System Isolation Boundaries.....	3-3
Powering I/O Circuits with the Auxiliary Supply	3-4
Powering I/O Circuits Using Separate Supplies	3-5
Sinking / Sourcing Concepts.....	3-6
I/O "Common" Terminal Concepts	3-7
Connecting DC I/O to Solid State Field Devices.....	3-8
Solid State Input Sensors.....	3-8
Solid State Output Loads	3-8
Relay Output Guidelines.....	3-10
Relay Outputs - Transient Suppression for Inductive Loads in a Control System ...	3-10
I/O Modules Position, Wiring and Specifications	3-15
Multiple Power Supply Configuration.....	3-15
Overview of I/O Expansion Configurations.....	3-16
Types of Modules Available for the Terminator System	3-17
Discrete Module Status Indicators.....	3-17
Color Coding of I/O Modules.....	3-17
Wiring the I/O Module Bases	3-18
Selecting Internal 24VDC Power Supply	3-19
Using Internal 24VDC Base Power	3-19
Using Internally Bussed 24VDC (T1K-08ND3, T1K-16ND3 only).....	3-19

External 24VDC Wiring Options.....	3-20
Using T1K-01AC for External 24VDC Power.....	3-20
Using an External 24VDC Power Supply.....	3-20
I/O Wiring Checklist	3-21
Output Module Fusing	3-21
I/O Module Hot Swap Feature	3-22
Hot Swap: I/O Module Replacement.....	3-22
Outputs Enable / Disable Switch	3-22
Check External 24VDC Wiring Before Hot Swapping.....	3-22
Calculating the Power Budget.....	3-23
Managing the Power Resource.....	3-23
Power Supply Specifications.....	3-23
Module Power Requirements	3-24
Power Budget Calculation Example.....	3-25
Power Budget Worksheet.....	3-26
I/O Specification Terms	3-27
Inputs or Outputs Per Module.....	3-27
Commons Per Module	3-27
Input Voltage Range.....	3-27
Output Voltage Range.....	3-27
Peak Voltage	3-27
AC Frequency.....	3-27
ON Voltage Level.....	3-27
OFF Voltage Level.....	3-27
Input impedance	3-27
Input Current.....	3-27
Minimum ON Current.....	3-27
Maximum OFF Current.....	3-27
Minimum Load.....	3-27
External DC Required	3-27
ON Voltage Drop	3-28
Maximum Leakage Current.....	3-28
Maximum Inrush Current.....	3-28
Base Power Required.....	3-28
OFF to ON Response.....	3-28

Table of Contents

ON to OFF Response.....	3-28
Terminal Type.....	3-28
Status Indicators.....	3-28
Weight	3-28
Fuses	3-28
T1K-01AC, T1K-01DC Power Supply	3-29
Dimensions	3-30
T1H-EBC Ethernet Base Controller (Obsolete)	3-31
Dimensions	3-32
T1K-EBC Ethernet Port Pin-out.....	3-32
T1K-EBC Serial Port Pin-out.....	3-32
T1H-EBC100 Ethernet Base Controller	3-33
Dimensions	3-34
T1K-EBC100 Ethernet Port Pin-out.....	3-34
T1K-EBC100 Serial Port Pin-out.....	3-34
T1K-DEVNETS.....	3-35
T1K-DEVNETS Serial Port Pin-out	3-36
Dimensions	3-36
T1K-DEVNETS DIP Switch Settings	3-36
T1K-MODBUS Base Controller.....	3-37
Dimensions	3-38
T1K-MODBUS DIP Switch Settings	3-38
T1K-RSSS Remote I/O Base Controller	3-39
Dimensions	3-40
T1K-RSSS DIP Switch Settings	3-40
T1K-RSSS Serial Port Pin-out.....	3-40
T1H-PBC PROFIBUS Base Controller.....	3-41
Dimensions	3-42
T1H-PBC Port Pin-out.....	3-42
T1K-08ND3 DC Input.....	3-43
Wiring & Dimensions	3-44
Jumper Selection	3-44
T1K-16ND3 DC Input.....	3-45
Wiring & Dimensions	3-46
Jumper Selection	3-46

T1K-08NA-1 AC Input	3-47
Wiring & Dimensions	3-48
T1K-16NA-1 AC Input	3-49
Wiring & Dimensions	3-50
T1K-08TD1 DC Output	3-51
Wiring & Dimensions	3-52
T1K-08TD2-1 DC Output	3-53
Wiring & Dimensions	3-54
T1H-08TDS Isolated DC Output	3-55
Wiring & Dimensions	3-56
T1K-16TD1 DC Output	3-57
Wiring & Dimensions	3-58
T1K-16TD2-1 DC Output	3-59
Wiring & Dimensions	3-60
T1K-08TA AC Output	3-61
Wiring & Dimensions	3-62
T1K-16TA AC Output	3-63
Wiring & Dimensions	3-64
T1K-08TAS AC Output	3-65
Wiring & Dimensions	3-66
T1K-08TR Relay Output	3-67
Wiring & Dimensions	3-68
T1K-16TR Relay Output	3-69
Wiring & Dimensions	3-70
T1K-08TRS Relay Output	3-71
Wiring & Dimensions	3-72
T1F-08AD-1 8-Channel Current Analog Input	3-73
Wiring & Dimensions	3-74
T1F-08AD-2 8-Channel Voltage Analog Input	3-75
Wiring & Dimensions	3-76
T1F-16AD-1 16-Channel Current Analog Input	3-77
Wiring & Dimensions	3-78

Table of Contents

T1F-16AD-2 16-Channel Voltage Analog Input	3-79
Wiring & Dimensions	3-80
T1F-08DA-1 8-Channel Current Analog Output	3-81
Wiring & Dimensions	3-82
T1F-08DA-2 8-Channel Analog Output	3-83
Wiring & Dimensions	3-84
T1F-16DA-1 16-Channel Current Analog Output	3-85
Wiring & Dimensions	3-86
T1F-16DA-2 16-Channel Voltage Analog Output	3-87
Wiring & Dimensions	3-88
T1F-16RTD RTD Input Module	3-89
Wiring & Dimensions	3-90
Setting Module Jumpers	3-91
T1F-RTD Data Format	3-92
T1F-16TMST Thermistor Input Module (Retired)	3-93
Wiring & Dimensions	3-94
Setting Module Jumpers	3-95
T1F-TMST Data Format	3-96
T1F-14THM 14-Channel Thermocouple Input	3-97
Wiring & Dimensions	3-98
Setting Module Jumpers	3-99
T1F-THM Data Format	3-99
Select the Conversion Units.....	3-99
T1F-8AD4DA-1 8-Channel Current Analog Input / 4-Channel Current Analog Output	3-101
Input Wiring & Dimensions	3-102
T1F-8AD4DA-1	3-103
Output Wiring & Dimensions	3-104
T1F-8AD4DA-2 8-Channel Voltage Analog Input / 4-Channel Voltage Analog Output	3-105
Input Wiring & Dimensions	3-106
T1F-8AD4DA-2	3-107
Output Wiring & Dimensions	3-108

T1H-CTRIO Counter I/O Module 3-109
 Wiring & Dimensions 3-110
 LED Indicators..... 3-110
 T1H-CTRIO Input Wiring Diagrams 3-111
 T1H-CTRIO Input Wiring Diagrams 3-112
 T1H-CTRIO Output Wiring Diagrams 3-113
 T1H-CTRIO Output Wiring Diagrams 3-114

T1K-08B(-1) I/O Module Base 3-115

T1K-16B(-1) I/O Module Base 3-115
 Dimensions 3-116

T1K-10CBL, T1K-10CBL-1 Expansion Cable 3-117
 Specifications 3-117
 Dimensions 3-118

T1K-5CBL-LL(-1) Expansion Cable 3-119

T1K-5CBL-RR(-1) Expansion Cable..... 3-119
 Dimensions 3-120

Cable Connection Examples..... 3-121

Chapter 4 - I/O Memory Map and Analog Module Resolution

Master / Slave Communications..... 4-2

Terminator I/O Backplane Communications 4-2

Discrete Input Module Memory Map 4-3

Discrete Output Module Memory Map 4-4

8-Channel Analog Input Module Memory Map..... 4-5

**16-Channel Analog Input Module
 (T1F-16AD-x, T1F-16RTD, T1F-16TMST and T1F-14THM)..... 4-7**
 T1F-14THM, T1F-16TMST and T1F-16RTD Channel Burnout Bit..... 4-7

16-Channel Analog Input Module Memory Map 4-8

Analog Input Module Resolution 4-10
 Input Module Resolution 4-10
 Channel Data Bits 4-10
 Analog and Digital Value Conversions..... 4-11

Table of Contents

T1F-08DA-x, Analog Output Module Memory Map	4-12
T1F-8AD4DA-x, Analog Output Module Memory Map	4-17
Analog Output Module Control Byte	4-21
Analog Output Module Resolution	4-25
Output Module Resolution	4-25
Channel Data Bits	4-25
Analog and Digital Value Conversions.....	4-26

Appendix A - European Union Directives (CE)

European Union (EU) Directives	A-2
Member Countries	A-2
Applicable Directives.....	A-2
Compliance	A-2
General Safety	A-4
Special Installation Manual.....	A-4
Other Sources of Information	A-4
Basic EMC Installation Guidelines.....	A-5
Enclosures.....	A-5
Electrostatic Discharge (ESD).....	A-5
AC Mains Filters.....	A-6
Suppression and Fusing.....	A-6
Internal Enclosure Grounding	A-6
Equip-potential Grounding	A-7
Communications and Shielded Cables.....	A-7
Analog and RS-232C Cables.....	A-8
Multidrop Cables.....	A-8
Shielded Cables within Enclosures.....	A-9
Analog Modules and RF Interference	A-9
Network Isolation.....	A-9
DC Powered Versions.....	A-9
Items Specific to the Terminator I/O System.....	A-10

GETTING STARTED



CHAPTER 1

In This Chapter...

About This Manual.....	1-2
Conventions Used.....	1-3
Terminator I/O Base Controllers.....	1-4
Terminator I/O System Components	1-5

About This Manual

The Purpose of this Manual

This manual is written for the user of the Terminator I/O line of field bus termination I/O products. This manual shows you how to install and wire the equipment. It provides specifications for the input and output modules.

Supplemental Manuals

In addition to this manual, you will want to have the specific manual for your Terminator I/O Base Controller. In some cases you may need an additional manual such as the master PLC User Manual or perhaps the manual for the PC-based control software you may be using.

Technical Support

We strive to make our manuals the best in the industry. We rely on your feedback to let us know if we are reaching our goal. If you cannot find the solution to your particular application, or, if for any reason you need technical assistance, please call us at:

770-844-4200

Our technical support group will be pleased to work with you to answer your questions. They are available Monday through Friday from 9:00 A.M. to 6:00 P.M. Eastern Time. We also encourage you to visit our web site where you can find technical and non-technical information about our products and our company.

<http://www.automationdirect.com>

Conventions Used



When you see the “notepad” icon in the left-hand margin, the paragraph to its immediate right will be a **special note**. The word **NOTE**: in boldface will mark the beginning of the text.



When you see the “exclamation mark” icon in the left-hand margin, the paragraph to its immediate right will be a warning. This information could prevent injury, loss of property, or even death (in extreme cases). The word **WARNING**: in boldface will mark the beginning of the text.

Key Topics for Each Chapter

The beginning of each chapter will list the key topics that can be found in that chapter.

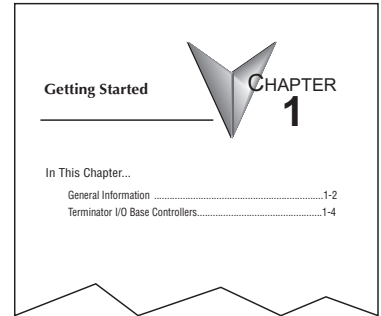

Terminator I/O Base Controllers

Terminator I/O offers five base controller modules. All modules include an on board RJ-12, RS-232C serial port.

The five base controllers are:

- Ethernet Base Controller
 - T1H-EBC (discontinued)
 - T1H-EBC100
- DeviceNet Base Controller
 - T1K-DEVNETS
- PROFIBUS™ DP Base Controller
 - T1H-PBC (discontinued)
- Modbus™ RTU Base Controller
 - T1K-MODBUS
- DirectLOGIC Remote I/O Base Controller
 - T1K-RSSS (discontinued)

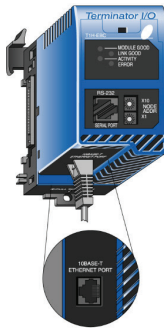

T1H-EBC

(Discontinued)

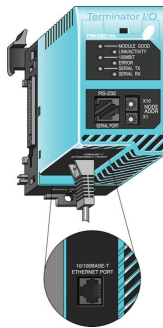

T1H-EBC100



T1K-DEVNETS



T1H-PBC

(Discontinued)



T1K-MODBUS



T1K-RSSS

(Discontinued)

Terminator I/O System Components

Terminator I/O is a modular system which combines the functions of terminal blocks and I/O modules for distributed I/O. Each Terminator I/O system has the following components: a Power Supply, a Base Controller, and one or more I/O Module(s). Terminator I/O systems can contain up to 16 I/O modules per slave (node). Each slave (node) system can be divided into one row of base I/O plus two rows of local expansion I/O using a base expansion cable.

Power Supplies

120/240 VAC and 12/24 VDC power supplies are available. The AC version has a built-in 24VDC supply. A power supply must be the leftmost component in a slave system followed by the base controller. Additional power supplies should be added between I/O modules to meet power budget requirements.

I/O Modules

A Terminator I/O module assembly consists of an I/O module and a separate base, as shown below. A complete range of discrete modules which support 12/24 VDC, 110/220 VAC and up to 7A relay outputs is offered. The analog I/O modules provide 12-bit and 14-bit resolution and several selections of I/O signal ranges (including bipolar). The temperature input modules provide 16 bit resolution with several temperature input range selections. All Terminator I/O modules can be Hot Swapped (replaced) without removing system power (except for the base controller and power supply). Refer to the I/O Module Hot Swap section in Chapter 3 for details.

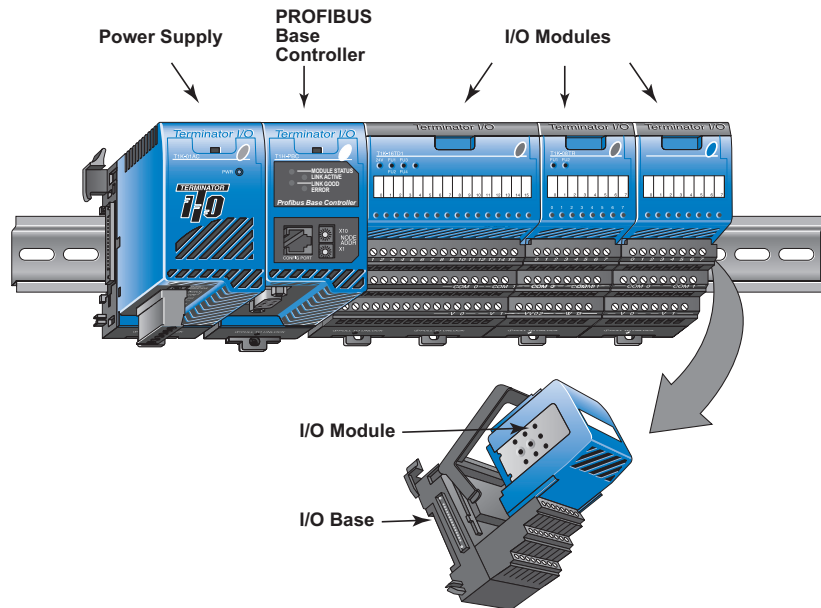

INSTALLATION AND WIRING



CHAPTER 2

In This Chapter...

Safety Guidelines.....	2-2
Mounting Guidelines	2-5
Assembling the Components.....	2-9
Multiple Power Supplies / Local Expansion Configurations.....	2-11
Power Supply Wiring Guidelines.....	2-15

Safety Guidelines



NOTE: *Products with CE marks perform their required functions safely and adhere to relevant standards as specified by CE directives provided they are used according to their intended purpose and that the instructions in this manual are adhered to. The protection provided by the equipment may be impaired if this equipment is used in a manner not specified in this manual. A listing of our international affiliates is available on our Web site: <http://www.automationdirect.com>*



WARNING: Providing a safe operating environment for personnel and equipment is your responsibility and should be your primary goal during system planning and installation. Automation systems can fail and may result in situations that can cause serious injury to personnel or damage to equipment. Do not rely on the automation system alone to provide a safe operating environment. You should use external electromechanical devices, such as relays or limit switches, that are independent of the PLC application to provide protection for any part of the system that may cause personal injury or damage. Every automation application is different, so there may be special requirements for your particular application. Make sure you follow all national, state, and local government requirements for the proper installation and use of your equipment.

Plan for Safety

The best way to provide a safe operating environment is to make personnel and equipment safety part of the planning process. You should examine every aspect of the system to determine which areas are critical to operator or machine safety. If you are not familiar with PLC system installation practices, or your company does not have established installation guidelines, you should obtain additional information from the following sources.

- NEMA — The National Electrical Manufacturers Association, located in Washington, D.C. publishes many different documents that discuss standards for industrial control systems. You can order these publications directly from NEMA. Some of these include:
 - ICS 1, General Standards for Industrial Control and Systems
 - ICS 3, Industrial Systems
 - ICS 6, Enclosures for Industrial Control Systems
- NEC — The National Electrical Code provides regulations concerning the installation and use of various types of electrical equipment. Copies of the NEC Handbook can often be obtained from your local electrical equipment distributor or your local library.
- Local and State Agencies — many local governments and state governments have additional requirements above and beyond those described in the NEC Handbook. Check with your local Electrical Inspector or Fire Marshall office for information.

Three Levels of Protection

The publications mentioned provide many ideas and requirements for system safety. At a minimum, you should follow these regulations. Also, you should use the following techniques, which provide three levels of system control.

- Emergency stop switch for disconnecting system power
- Mechanical disconnect for output module power
- Orderly system shutdown sequence in the PLC control program

Emergency Stops

It is recommended that emergency stop circuits be incorporated into the system for every machine controlled by a PLC. For maximum safety in a PLC system, these circuits must not be wired into the controller, but should be hardwired external to the PLC. The emergency stop switches should be easily accessed by the operator and are generally wired into a master control relay (MCR) or a safety control relay (SCR) that will remove power from the PLC I/O system in an emergency.

MCRs and SCRs provide a convenient means for removing power from the I/O system during an emergency situation. By de-energizing an MCR (or SCR) coil, power to the input (optional) and output devices is removed. This event occurs when any emergency stop switch opens. However, the PLC continues to receive power and operate even though all its inputs and outputs are disabled.

The MCR circuit could be extended by placing a PLC fault relay (closed during normal PLC operation) in series with any other emergency stop conditions. This would cause the MCR circuit to drop the PLC I/O power in case of a PLC failure (memory error, I/O communications error, etc.).

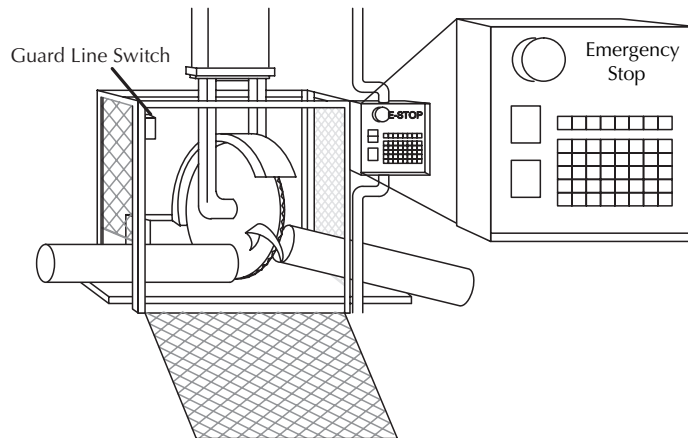

Emergency Power Disconnect

A properly rated emergency power disconnect should be used to power the PLC controlled system as a means of removing the power from the entire control system. It may be necessary to install a capacitor across the disconnect to protect against a condition known as “outrush”. This condition occurs when the output Triacs are turned off by powering off the disconnect, thus causing the energy stored in the inductive loads to seek the shortest distance to ground, which is often through the Triacs.

After an emergency shutdown or any other type of power interruption, there may be requirements that must be met before the PLC control program can be restarted. For example, there may be specific register values that must be established (or maintained from the state prior to the shutdown) before operations can resume. In this case, you may want to use retentive memory locations, or include constants in the control program to ensure a known starting point.

Orderly System Shutdown

Ideally, the first level of fault detection is the PLC control program, which can identify machine problems. Certain shutdown sequences should be performed. The types problems are usually things such as jammed parts, etc. that not pose a risk of personal injury or equipment damage.

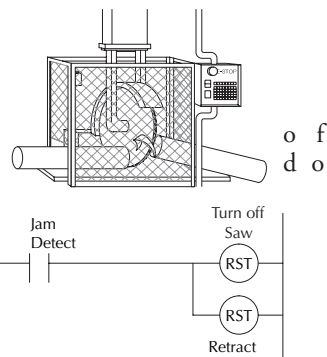

WARNING: The control program must not be the only form of protection for any problems that may result in a risk of personal injury or equipment damage.

Class 1, Division 2, Zone 2 Approval

This equipment is suitable for use in Class 1, Zone 2, Division 2, groups A, B, C and D or non-hazardous locations only.



WARNING: Explosion Hazard! Substitution of components may impair suitability for Class 1, Division 2. Do not disconnect equipment unless power has been switched off or area is known to be non-hazardous.

WARNING: Explosion Hazard! Do not disconnect equipment unless power has been switched off or the area is known to be non-hazardous.

WARNING: All models used with connector accessories must use R/C (ECBT2) mating plug for all applicable models. All mating plugs shall have suitable ratings for device.

WARNING: This equipment is designed for use in Pollution Degree 2 environments (installed within an enclosure rated at least IP54).

WARNING: Transient suppression must be provided to prevent the rated voltage from being exceeded by 140%.

Mounting Guidelines

Before installing the Terminator I/O system you will need to know the dimensions of the components. The diagrams on the following pages provide the component dimensions to use in defining your enclosure specifications. Remember to leave room for potential expansion.



NOTE: If you are using other components in your system, refer to the appropriate manual to determine how those units can affect mounting dimensions.

Dimensions

The following diagrams show the base controller, power supply and I/O module dimensions. Terminator I/O components mount on 35mm wide DIN rail.

Base Controller / Power Supply

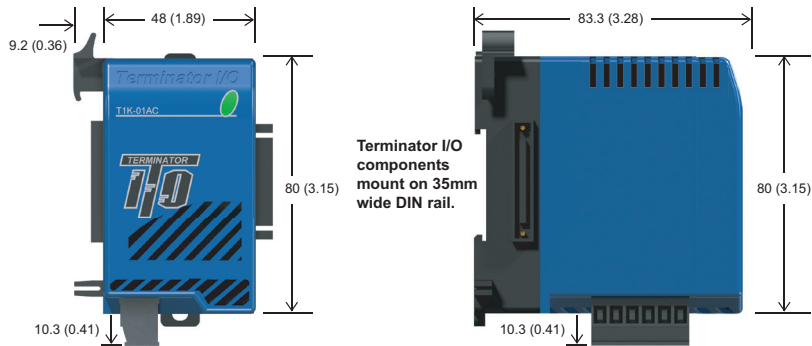

I/O Modules

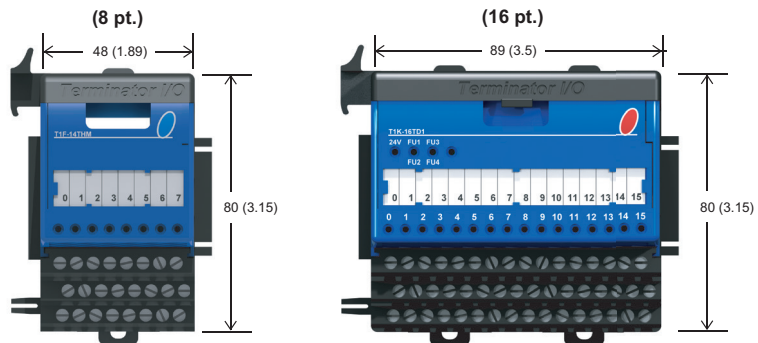

Panel Mounting and Layout

It is important to design your panel properly to help ensure that the Terminator I/O products operate within their environmental and electrical limits. The system installation should comply with all appropriate electrical codes and standards. It is important that the system also conforms to the operating standards for the application to ensure proper performance.

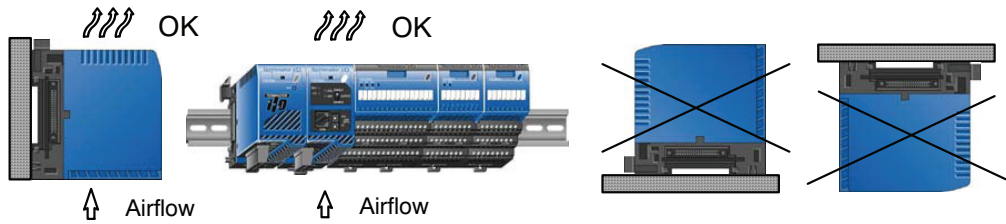

1. Only mount the unit horizontally as shown to provide proper ventilation.
2. When mounting more than one unit in a cabinet, there should be a minimum of 7.2 in. (183mm) between them.
3. Provide a minimum clearance of 2in. (50mm) between the units and all sides of the cabinet. There should also be at least 1.2 in. (30mm) of clearance between the base and any wiring ducts.

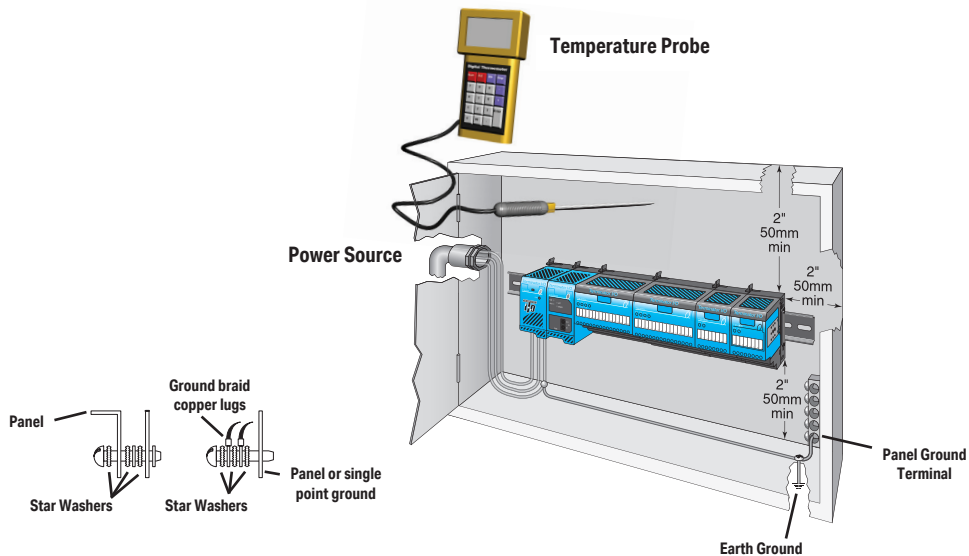

4. There must be a minimum of 2in. (50mm) clearance between the panel door and the nearest Terminator I/O component.
5. The ground terminal on the Terminator I/O power supply must be connected to a single point ground. Use copper stranded wire to achieve a low impedance. Copper eye lugs should be crimped and soldered to the ends of the stranded wire to ensure good surface contact. Remove anodized finishes and use copper lugs and star washers at termination points. A general rule is to achieve a 0.1 ohm of DC resistance between the Terminator I/O slave and the single point ground.
6. There must be a single point ground (i.e. copper bus bar) for all devices in the panel requiring an earth ground return. The single point of ground must be connected to the panel ground termination. The panel ground termination must be connected to earth ground. For this connection you should use 12AWG stranded copper wire as a minimum. Minimum wire sizes, color coding, and general safety practices should comply with appropriate electrical codes and standards for your region. A good common ground reference (earth ground) is essential for proper operation of the Terminator I/O. There are several methods of providing an adequate common ground reference, including: a) Installing a ground rod as close to the panel as possible. b) Connection to incoming power system ground.
7. Properly evaluate any installation where the ambient temperature may approach the lower or upper limits of the specifications. Place a temperature probe in the panel, close the door and operate the system until the ambient temperature has stabilized. If the ambient temperature is not within the operating specification for the Terminator I/O system, measure points in the panel in consideration for installing a cooling/heating source to provide the ambient temperature to meet the Terminator I/O operating specifications.
8. Device mounting bolts and ground braid termination bolts should be #10 copper bolts or equivalent. Tapped holes instead of nut-bolt arrangements should be used whenever possible. To ensure good contact on termination areas impediments such as, paint, other coating or corrosion should be removed in the area of contact.
9. The system is designed to be powered by 110/220 VAC or 24VDC normally available throughout an industrial environment. Isolation transformers and noise suppression devices are not normally necessary, but may be helpful in eliminating/reducing suspect power problems.

Enclosures

Your selection of a proper enclosure is important to ensure safe and proper operation of your Terminator I/O system. Applications of Terminator I/O systems vary and may require additional features. The minimum considerations for enclosures include:

- Conformance to electrical standards
- Protection from the elements in an industrial environment
- Common ground reference
- Maintenance of specified ambient temperature
- Access to equipment
- Security or restricted access
- Sufficient space for proper installation and maintenance of equipment

Environmental Specifications

The following table lists the environmental specifications that apply to the Terminator I/O modules. Be sure to check the specifications of the controller you are using. Also refer to the appropriate I/O module specifications in Chapter 3 for the temperature derating curves for the specific module.

Specification	Rating
Storage temperature	-4°F to 158°F (-20°C to 70°C)
Ambient operating temperature	32°F to 131°F (0°C to 55°C)
Ambient humidity*	5%–95% relative humidity (non-condensing)
Vibration resistance	MIL STD 810C, Method 514.2
Shock resistance	MIL STD 810C, Method 516.2
Noise Immunity	NEMA (ICS3-304) Impulse noise 1 μ s, 1000V FCC class A RFI (144MHz, 430MHz 10W, 10cm)
Atmosphere	No corrosive gases. The level for the environmental pollution = 2. (UL840)

* Equipment will operate at low humidity. However, static electricity problems occur much more frequently at lower humidity levels. Make sure you take adequate precautions when you touch the equipment. Consider using ground straps, anti-static floor coverings, etc., if you use the equipment in low humidity environments.

Power

The power source must be capable of supplying voltage and current complying with the base power supply specifications.

Specification	AC Power Supply	DC Power Supply
Part Number	T1K-01AC	T1K-01DC
Input Voltage Range	110/220 VAC (85–264 VAC) 50/60 Hz (47–63 Hz)	12/24 VDC (10.8–26.4 VDC) with less than 10% ripple
Maximum Inrush Current	20A	10A
Maximum Power	50VA	20W
Voltage Withstand (dielectric)	1 minute @ 1500VAC between primary, secondary, field ground	
Insulation Resistance	> 10M Ω at 500VDC	
Auxiliary 24VDC Output	20–28 VDC, 10% ripple max. 300mA. Max. 500mA @ 24VDC can be achieved if the 5VDC power budget rating of 2000mA is reduced to 1500mA. See power budget section.	None

Agency Approvals

Some applications require agency approvals. Typical agency approvals which your application may require are:

- CUL (Canadian Underwriters' Laboratories, Inc.)
- UL (Underwriters' Laboratories, Inc.)
- CSA (Canadian Standards Association)
- FM (Factory Mutual Research Corporation)

Assembling the Components

Assembling the I/O Modules and Bases

INSERT MODULE INTO BASE

1. Pull base arm back to allow space for module to enter base.
2. Align module slides with base track.
3. Press module firmly into base.

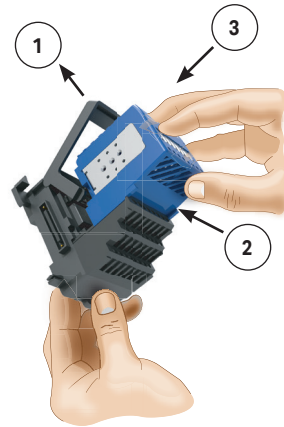

Mounting the Components on DIN Rail

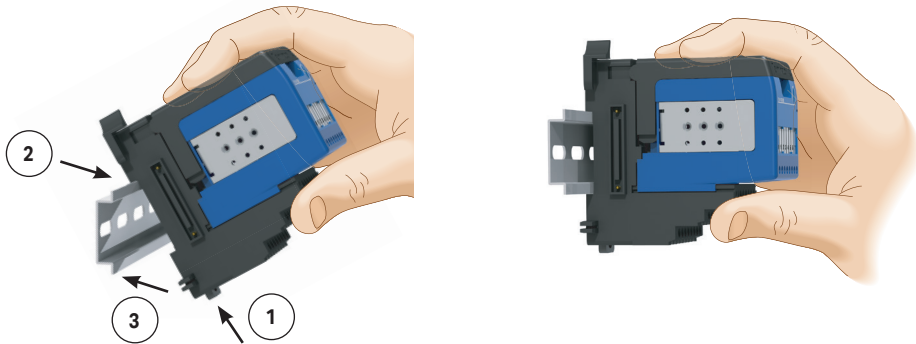

NOTE: Do not force the base controller on the DIN rail. Due to slight size variations in different manufacturers' DIN rail, it may be necessary to first unlatch the locking tab, rotate the module into place, then latch the locking tab.

INSTALL ON DIN RAIL

1. Make sure the locking tab is in the latched position (pushed in).
2. Hook upper tab over upper flange of DIN rail.
3. Tilt the unit toward DIN rail until it snaps securely to DIN rail.

Connecting the Components on the DIN Rail

SLIDE ASSEMBLY INTO POSITION ON THE DIN RAIL



Slide the module assembly on the DIN rail until the clip arm attaches securely to the adjacent module.



NOTE: One power supply is required in the leftmost component position followed by the base controller. Additional power supplies should be added between I/O modules as necessary to meet power budget requirements (see ch 3, page 3-18). Each power supply powers the modules to its right, but is interrupted by the next power supply.

Removing I/O Modules from the Base

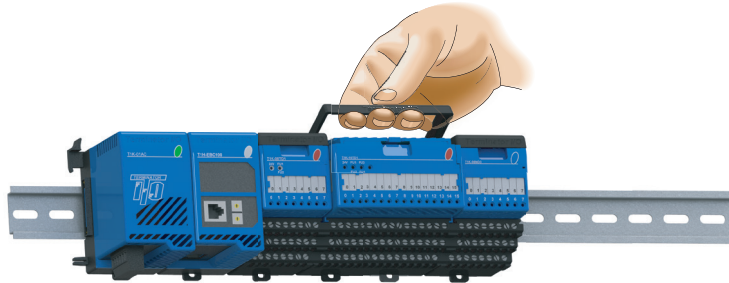

To remove a module from the base, grip the center of the base arm and rotate outward releasing the module. Lift the module from the base.

To remove a module assembly from the DIN rail, lift the clip arm up and slide the module assembly away from the adjacent module. Pull the locking tab down (out) and lift the assembly off the DIN rail. Refer to the “I/O Module Hot Swap Feature” section in Chapter 3 to remove an I/O module with Terminator I/O system power ON.

Multiple Power Supplies / Local Expansion Configurations

Multiple Power Supply Configuration

It is possible to have multiple power supplies in a single slave (node) system to meet power budget requirements. **One power supply is required in the leftmost component position followed by the base controller.** Additional power supplies should be added between I/O modules as necessary to meet power budget requirements. There are some restrictions on where power supplies can be placed in the system when using the T1K-05CBL-RR(-1) expansion base cable. Each power supply powers the modules to its right, but is interrupted by the next power supply. Each slave (node) system can be divided into one row of base I/O plus two rows of local expansion I/O up to a total of 16 I/O modules.

Expansion cables are available in two configurations: one that allows 24VDC base power to pass and one that does not (both cables pass the 5VDC base power). The “-1” version of the expansion cables, pass 24VDC on an isolated wire. Any local expansion DC input modules configured for “internal power” (current sourcing) must either have a power supply preceding it on the same base or have a “-1” version cable pass 24VDC from a power supply on the preceding base.

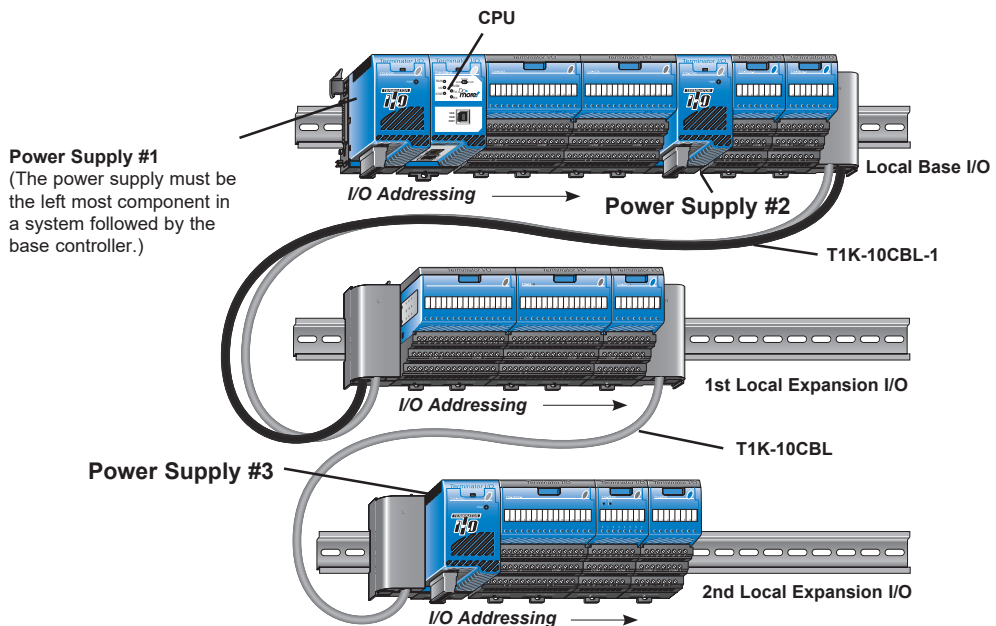

Example Using T1K-10CBL and T1K-10CBL-1 Expansion Cables

System shown above: The first power supply powers the base controller and the two I/O modules to its right. The second power supply powers the two modules to its right and the three I/O modules on the first local expansion base. Power Supply #3 powers the three I/O modules to its right on the second local expansion base. This serves as an example only, your power budget requirements will vary depending on the I/O modules used.

Example Using T1K-05CBL-RR-1 and T1K-05CBL-LL Expansion Cables



NOTE: The T1K-05CBL-RR-1 expansion cable with an isolated 24VDC lead was discontinued in 2015 and is no longer available. The following examples show this cable. As an alternative, consider using the T1K-10CBL(-1) cables as shown in the example on the preceding page.

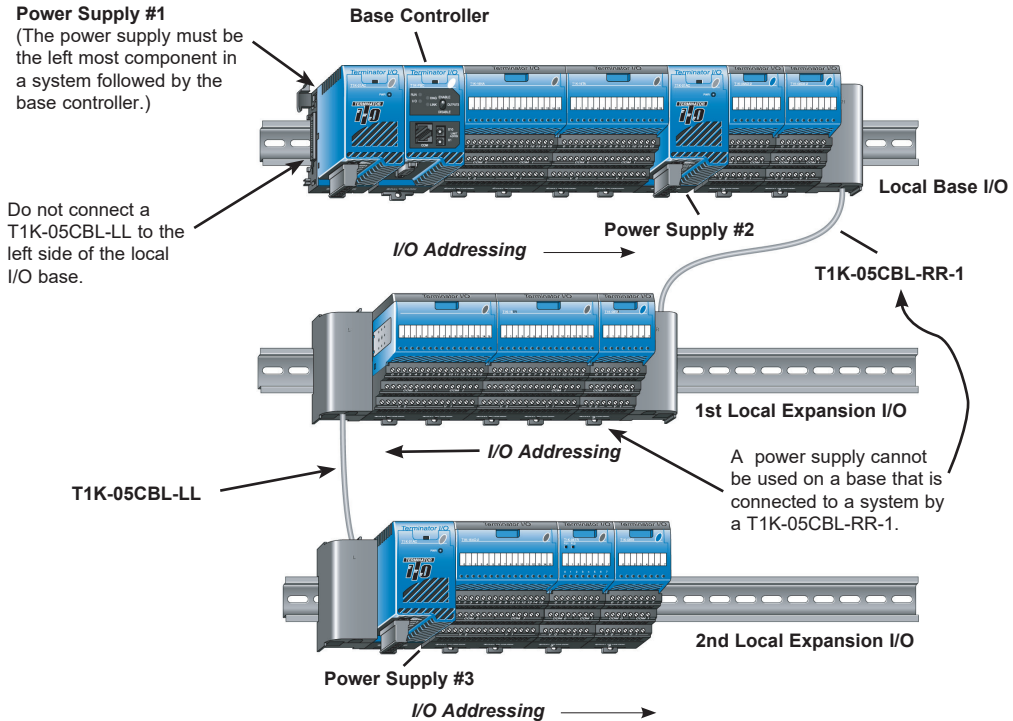

System shown above: The first power supply powers the base controller and the two I/O modules to its right. The second power supply powers the two modules to its right and the three I/O modules on the first local expansion base. When a T1K-05CBL-RR-1 is used, the expansion I/O assignments are from right to left (reversed). A power supply cannot be used on a base that is connected to a system by a T1K-05CBL-RR-1. Power Supply #3 powers the three I/O modules to its right on the second local expansion base. This serves as an example only, your power budget requirements will vary depending on the I/O modules used.

Example Using T1K-10CBL and T1K-05CBL-RR-1 Expansion Cables

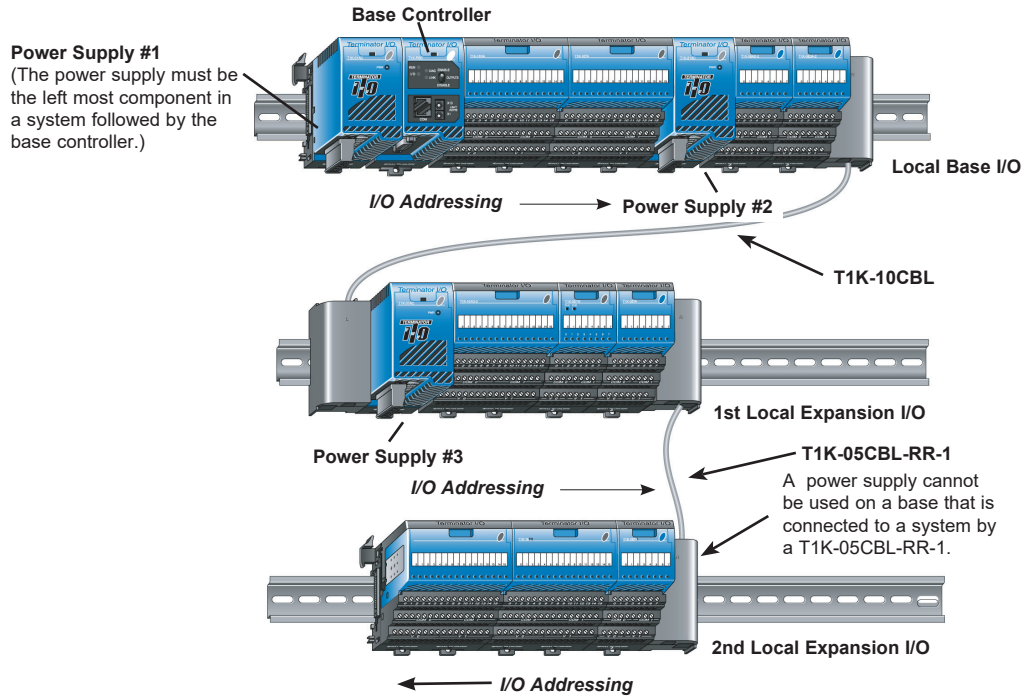

System shown above: The first power supply powers the base controller and the two I/O modules to its right. The second power supply powers the two modules to its right. Power Supply #3 powers the three I/O modules to its right on the first local expansion base and the three I/O modules on the second local expansion base. When a T1K-05CBL-RR-1 is used, the expansion I/O assignments are from right to left (reversed). A power supply cannot be used on a base that is connected to a system by a T1K-05CBL-RR-1. This serves as an example only, your power budget requirements will vary depending on the I/O modules used.

Example Using T1K-05CBL-RR-1 Expansion Cables

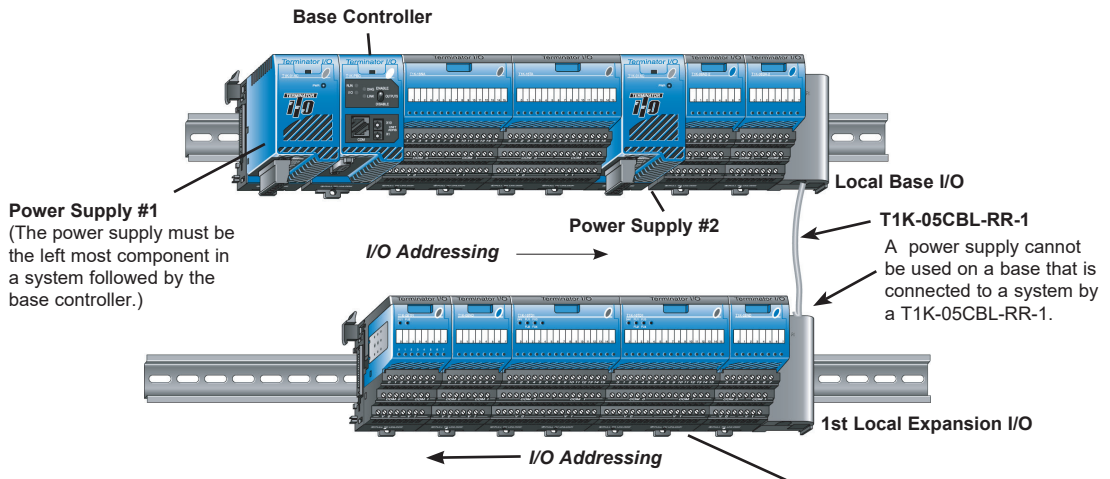

System shown above: The first power supply powers the base controller and the two I/O modules to its right. The second power supply powers the two modules to its right and the five I/O modules on the first local expansion base. When a T1K-05CBL-RR-1 is used, the expansion I/O assignments are from right to left (reversed). A power supply cannot be used on a base that is connected to a system by a T1K-05CBL-RR-1. This serves as an example only, your power budget requirements will vary depending on the I/O modules used.

Power Supply Wiring Guidelines

Power Wiring

The diagram below shows the terminal connections located on the Terminator I/O AC and DC power supplies. The table below shows the wire size and the recommended power supply terminal screw torque.

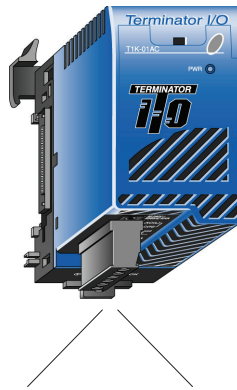

110/220 VAC Terminal Strip

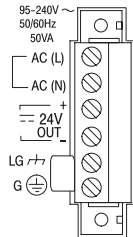

T1K-01AC

12/24 VDC Terminal Strip

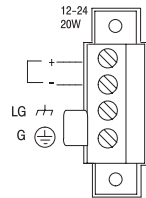

T1K-01DC

Power Supply	T1K-01AC	T1K-01DC
Wire Size	Solid: 24-12 AWG Stranded: 24-12 AWG	Solid: 24-12 AWG Stranded: 24-12 AWG
Recommended Torque	4.43-5.31 lb-in (0.5-0.6 N·m)	4.43-5.31 lb-in (0.5-0.6 N·m)

I/O WIRING AND SPECIFICATIONS



CHAPTER 3

In This Chapter...

I/O Wiring Strategies	3-3
I/O Modules Position, Wiring and Specifications	3-15
I/O Module Hot Swap Feature	3-22
Calculating the Power Budget.....	3-23
I/O Specification Terms.....	3-27
T1K-01AC, T1K-01DC Power Supply.....	3-29
T1H-EBC Ethernet Base Controller (Retired).....	3-31
T1H-EBC100 Ethernet Base Controller	3-33
T1K-DEVNETS.....	3-35
T1K-MODBUS Base Controller.....	3-37
T1K-RSSS Remote I/O Base Controller (Retired).....	3-39
T1H-PBC PROFIBUS Base Controller (Retired)	3-41
T1K-08ND3 DC Input.....	3-43
T1K-16ND3 DC Input.....	3-45
T1K-08NA-1 AC Input	3-47
T1K-16NA-1 AC Input	3-49
T1K-08TD1 DC Output	3-51
T1K-08TD2-1 DC Output	3-53
T1H-08TDS Isolated DC Output.....	3-55
T1K-16TD1 DC Output	3-57
T1K-16TD2-1 DC Output	3-59
T1K-08TA AC Output.....	3-61

T1K-16TA AC Output.....	3-63
T1K-08TAS AC Output.....	3-65
T1K-08TR Relay Output.....	3-67
T1K-16TR Relay Output.....	3-69
T1K-08TRS Relay Output.....	3-71
T1F-08AD-1 8-Channel Current Analog Input.....	3-73
T1F-08AD-2 8-Channel Voltage Analog Input.....	3-75
T1F-16AD-1 16-Channel Current Analog Input	3-77
T1F-16AD-2 16-Channel Voltage Analog Input	3-79
T1F-08DA-1 8-Channel Current Analog Output.....	3-81
T1F-08DA-2 8-Channel Analog Output	3-83
T1F-16DA-1 16-Channel Current Analog Output	3-85
T1F-16DA-2 16-Channel Voltage Analog Output	3-87
T1F-16RTD RTD Input Module	3-89
T1F-16TMST Thermistor Input Module (Retired).....	3-93
T1F-14THM 14-Channel Thermocouple Input.....	3-97
Setting Module Jumpers	3-99
T1F-8AD4DA-1 8-Channel Current Analog Input 4 Channel Current Analog Output.....	3-101
T1F-8AD4DA-1.....	3-103
T1F-8AD4DA-2 8-Channel Voltage Analog Input 4 Channel Voltage Analog Output	3-105
T1F-8AD4DA-2.....	3-107
T1H-CTRIO Counter I/O Module	3-109
T1K-08B(-1) I/O Module Base	3-115
T1K-16B(-1) I/O Module Base	3-115
T1K-10CBL, T1K-10CBL-1 Expansion Cable.....	3-117
T1K-5CBL-LL(-1) Expansion Cable	3-119
T1K-5CBL-RR(-1) Expansion Cable.....	3-119
Cable Connection Examples.....	3-121

I/O Wiring Strategies

Terminator I/O System Isolation Boundaries

The Terminator I/O system is very flexible and will work in many different wiring configurations. By studying this section before actual installation, you can probably find the best wiring strategy for your application. This will help to lower system cost, wiring errors, and avoid safety problems.

Terminator I/O system circuitry is divided into three main regions separated by isolation boundaries, shown in the drawing below. Electrical isolation provides safety, so that a fault in one area does not damage another. A transformer in the power supply provides magnetic isolation between the primary and secondary sides. Opto-couplers provide optical isolation in Input and Output circuits. This isolates logic circuitry from the field side, where factory machinery connects. Note the discrete inputs are isolated from the discrete outputs, because each is isolated from the logic side. Isolation boundaries protect the operator interface (and the operator) from power input faults or field wiring faults. When wiring a Terminator I/O system, it is extremely important to avoid making external connections that connect logic side circuits to any other.

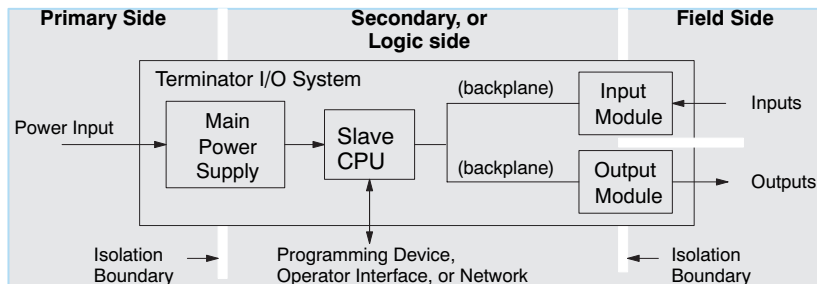

The next figure shows the physical layout of a Terminator I/O system, as viewed from the front. In addition to the basic circuits covered above, AC-powered bases include an auxiliary +24VDC power supply with its own isolation boundary. Since the supply output is isolated from the other three circuits, it can power input and/or output circuits!

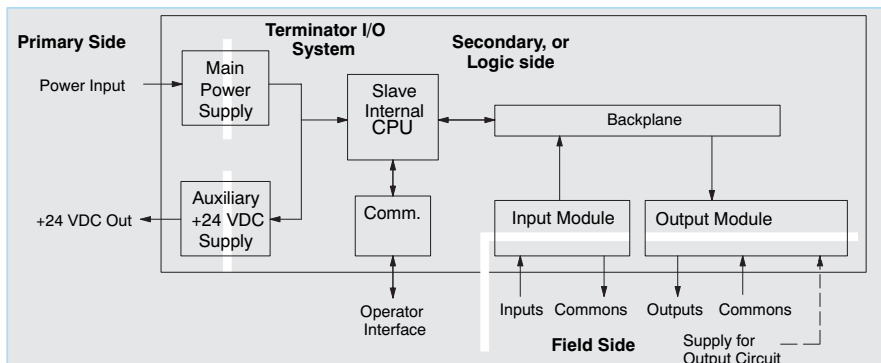

In some cases, using the built-in auxiliary +24VDC supply can result in a cost savings for your control system. It can power combined loads up to 500mA if power budget allows. Be careful not to exceed the current rating of the supply. If you are the system designer for your application, you may be able to select and design in field devices which can use the +24VDC auxiliary supply.

Powering I/O Circuits with the Auxiliary Supply

All AC power supplies feature an internal auxiliary supply. If input devices AND output loads need +24VDC power, the auxiliary supply may be able to power both circuits as shown in the following diagram.

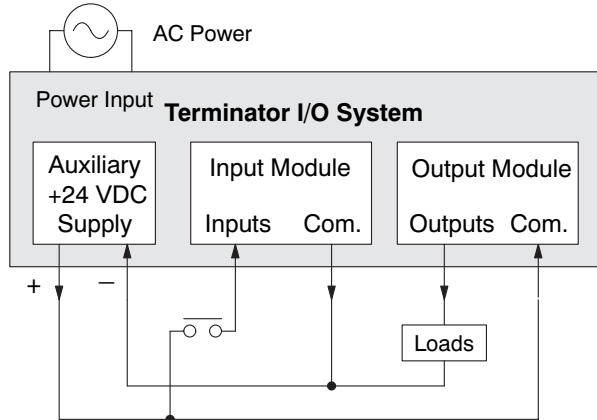

DC-powered units are designed for application environments in which low-voltage DC power is more readily available than AC. These include a wide range of battery-powered applications, such as remotely-located control, in vehicles, portable machines, etc. For this type of application, all input devices and output loads typically use the same DC power source. Typical wiring for DC-powered applications is shown in the following diagram.

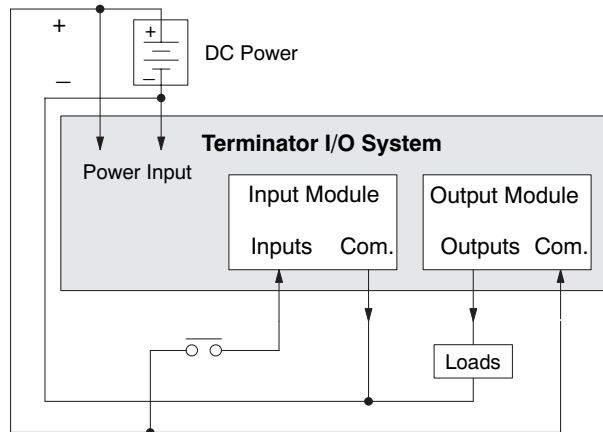

Powering I/O Circuits Using Separate Supplies

In most applications it will be necessary to power the input devices from one power source, and to power output loads from another source. Loads often require high-energy AC power, while input sensors use low-energy DC. If a machine operator is likely to come in close contact with input wiring, then safety reasons also require isolation from high-energy output circuits. It is most convenient if the loads can use the same power source as the Terminator I/O system, and the input sensors can use the auxiliary supply, as shown to the left in the figure below.

If the loads cannot be powered from the system supply, then a separate supply must be used as shown to the right in the figure below.

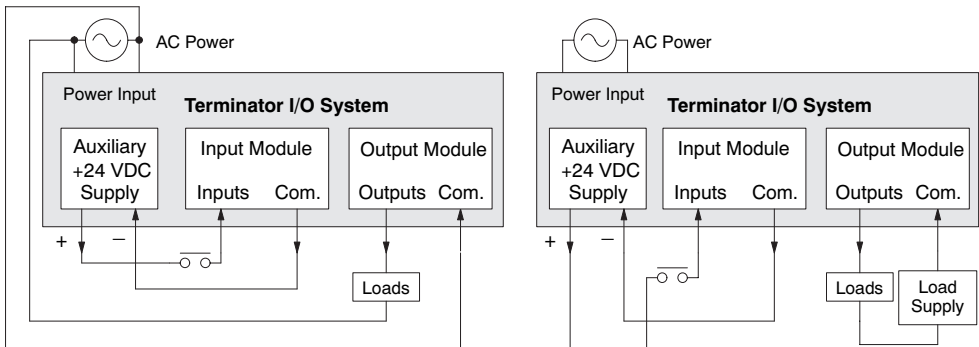

Some applications will use the external power source to also power the input circuit. This typically occurs on DC-powered systems, as shown in the drawing below to the left. The inputs share the system power source supply, while the outputs have their own separate supply.

A worse-case scenario, from a cost and complexity view-point, is an application which requires separate power sources for the Terminator I/O system, input devices, and output loads. The example wiring diagram below on the right shows how this can work, but also the auxiliary supply output is an unused resource. You will want to avoid this situation if possible.

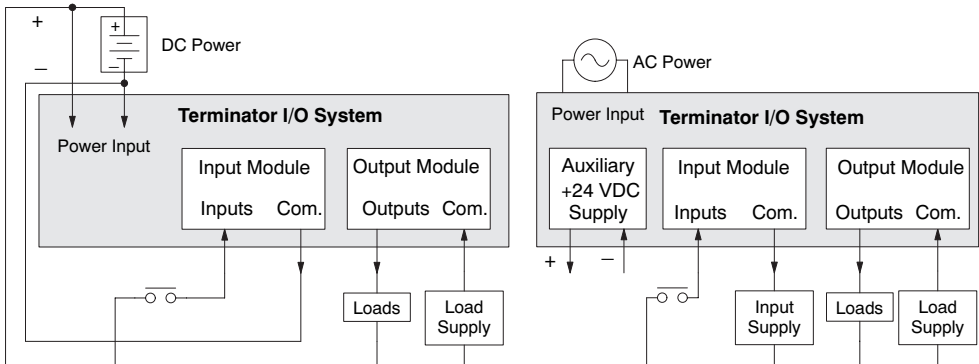

Sinking / Sourcing Concepts

Before going further in the study of wiring strategies, you must have a solid understanding of “sinking” and “sourcing” concepts. Use of these terms occurs frequently in input or output circuit discussions. It is the goal of this section to make these concepts easy to understand, further ensuring your success in installation. First the following short definitions are provided, followed by practical applications.

Sinking = provides a path to supply ground (-)

Sourcing = provides a path to supply source (+)

First you will notice these are only associated with DC circuits and not AC, because of the reference to (+) and (-) polarities. Therefore, sinking and sourcing terminology only applies to DC input and output circuits. Input and output points that are sinking or sourcing only can conduct current in only one direction. This means it is possible to connect the external supply and field device to the I/O point with current trying to flow in the wrong direction, and the circuit will not operate. However, you can successfully connect the supply and field device every time by understanding “sourcing” and “sinking”.

For example, the figure to the right depicts a “sinking” input. To properly connect the external supply, you will have to connect it so the input provides a path to ground (-). Start at the Terminator I/O system input terminal, follow through the input sensing circuit, exit at the common terminal, and connect the supply (-) to the common terminal. By adding the switch, between the supply (+) and the input, the circuit has been completed. Current flows in the direction of the arrow when the switch is closed.

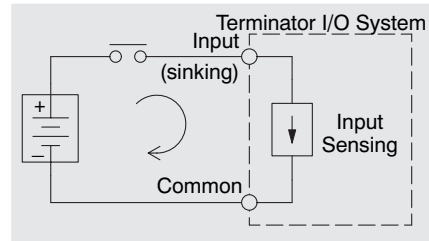

By applying the circuit principle above to the four possible combinations of input/output sinking/sourcing types as shown below. The I/O module specifications at the end of this chapter list the input or output type.

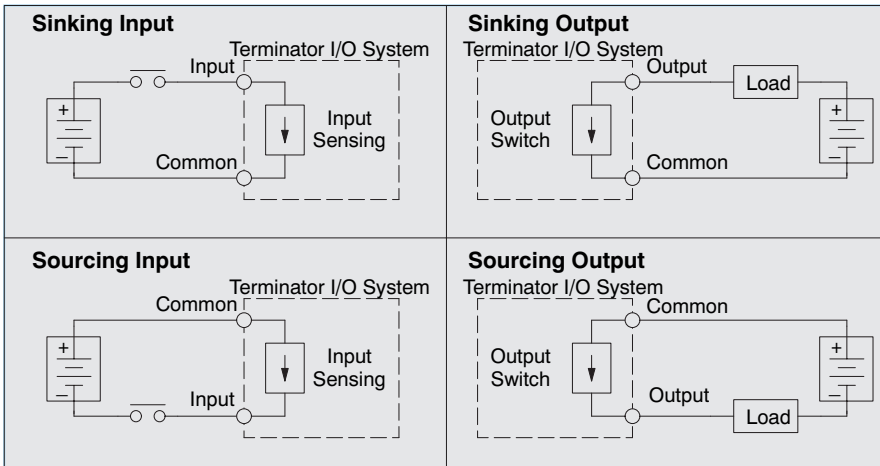

I/O "Common" Terminal Concepts

In order for an I/O circuit to operate, current must enter at one terminal and exit at another. Therefore, at least two terminals are associated with every I/O point. In the figure to the right, the Input or Output terminal is the main path for the current. One additional terminal must provide the return path to the power supply..

If there was unlimited space and budget for I/O terminals, every I/O point could have two dedicated terminals as the figure above shows. However, providing this level of flexibility is not practical or even necessary for most applications. So, most Input or Output points are in groups which share the return path (called commons). The figure to the right shows a group (or bank) of 4 input points which share a common return path. In this way, the four inputs require only five terminals instead of eight.

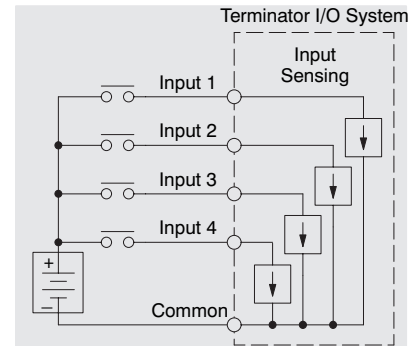
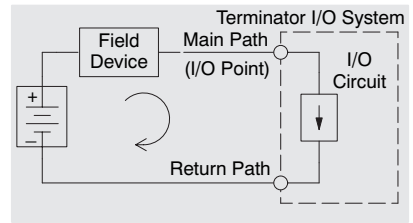

NOTE: In the circuit above, the current in the common path is 4 times any channel's input current when all inputs are energized. This is especially important in output circuits, where heavier gauge wire is sometimes necessary on commons.

Most Terminator I/O input and output modules group their I/O points into banks that share a common return path. The best indication of I/O common grouping is on the wiring label, such as the one shown to the right. The miniature schematic shows two banks of circuits with four output points in each. The common terminal for each is labeled COM 0 and COM 1, respectively.

In this wiring label example, the positive terminal of a DC supply connects to the common terminals. Some symbols you will see on the wiring labels, and their meanings are:

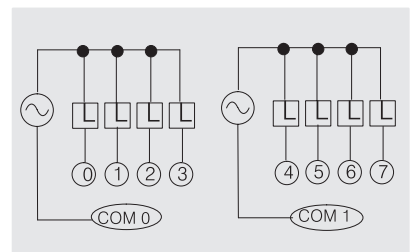
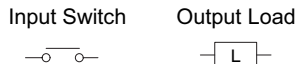
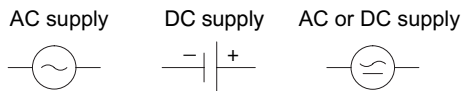

Connecting DC I/O to Solid State Field Devices

In the previous section on Sourcing and Sinking concepts, the DC I/O circuits were explained to only allow current to flow one way. This is also true for many of the field devices which have solid-state (transistor) interfaces. In other words, field devices can also be sourcing or sinking. *When connecting two devices in a series DC circuit, one must be wired as sourcing and the other as sinking:*

Solid State Input Sensors

Terminator I/O DC input modules are flexible because they detect current flow in either direction, so they can be wired as either sourcing or sinking. In the following circuit, a field device has an open-collector NPN transistor output. It sinks current from the input point, which sources current. The power supply can be the +24V auxiliary supply or another supply which sources current. The power supply can be the +24VDC or +24VDC, as long as the input specifications are met.

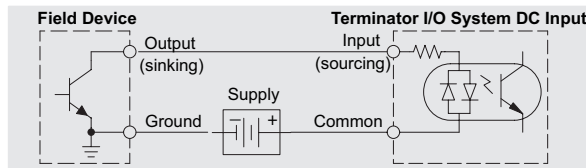

In the next circuit, a field device has an open-emitter PNP transistor output. It sources current to the input point, which sinks the current back to ground. Since the field device is sourcing current, no additional power supply is required.

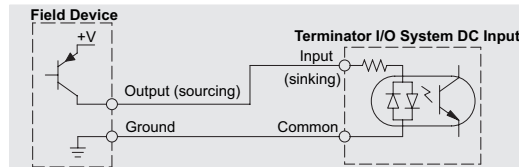

Solid State Output Loads

Sometimes an application requires connecting an output point to a solid state input on a device. This type of connection is usually made to carry a low-level control signal, not to send DC power to an actuator.

Several of the Terminator I/O DC output modules are the sinking type. This means that each DC output provides a path to ground when it is energized. In the following circuit, the output point sinks current to the output common when energized. It is connected to a sourcing input of a field device input.

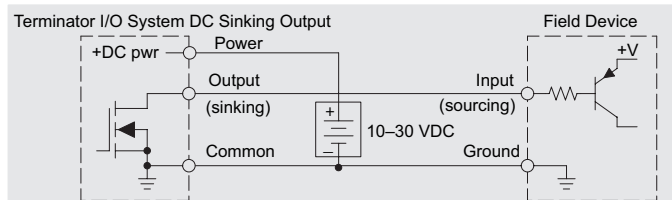

In the next example a sinking DC output point is connected to the sinking input of a field device. This is a little tricky, because both the Terminator I/O system output and field device input are sinking type. Since the circuit must have one sourcing and one sinking device, a sourcing capability needs to be added to the Terminator I/O system output by using a pull-up resistor. In the circuit below, resistor $R_{pull-up}$ is connected from the output to the DC output circuit power input.

Example: Circuit with no Suppression

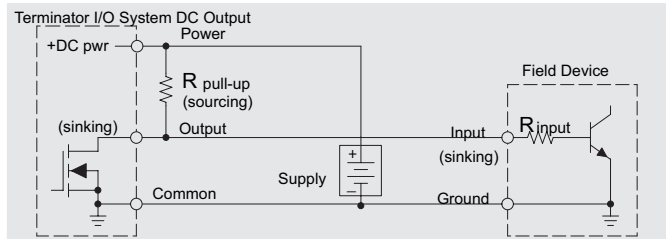

NOTE 1: DO NOT attempt to drive a heavy load (>25mA) with this pull-up method.

NOTE 2: Using the pull-up resistor to implement a sourcing output has the effect of inverting the output point logic. In other words, the field device input is energized when the Terminator I/O system output is OFF, from a ladder logic point-of-view. Your ladder program must comprehend this and generate an inverted output. Or, you may choose to cancel the effect of the inversion elsewhere, such as in the field device.

It is important to choose the correct value of $R_{pull-up}$. In order to do so, you need to know the nominal input current to the field device (I_{input}) when the input is energized. If this value is not known, it can be calculated as shown (a typical value is 15mA). Then use I_{input} and the voltage of the external supply to compute $R_{pull-up}$. Then calculate the power $P_{pull-up}$ (in watts), in order to size $R_{pull-up}$ properly.

Of course, the easiest way to drive a sinking input field device as shown below is to use a

$$I_{input} = \frac{V_{input} \text{ (turn-on)}}{R_{input}}$$

$$R_{pull-up} = \frac{V_{supply} - 0.7}{I_{input}} - R_{input}$$

$$P_{pull-up} = \frac{V_{supply}^2}{R_{pull-up}}$$

DC sourcing output module. The Darlington NPN stage will have about 1.5 V ON-state saturation, but this is not a problem with low-current solid-state loads.

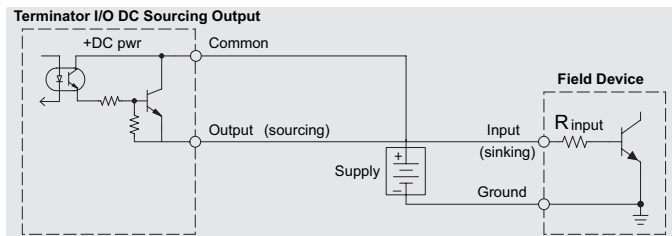

Relay Output Guidelines

Several output modules in the Terminator I/O family feature relay outputs: T1K-08TR, T1K-16TR, and T1K-08TRS. Relays are best for the following applications:

- Loads that require higher currents than the solid-state outputs can deliver
- Cost-sensitive applications
- Some output channels need isolation from other outputs (such as when some loads require different voltages than other loads)

Some applications in which NOT to use relays:

- Loads that require currents under 10mA
- Loads which must be switched at high speed or heavy duty cycle

Relay output module contacts are available in Form A type, or SPST (single pole, single throw) normally open.

Some relay output module's share common relay terminals, which connect to the wiper contact in each relay of the bank. Other relay modules have relays which are completely isolated from each other. In all cases, the module drives the relay coil when the corresponding output point is on.

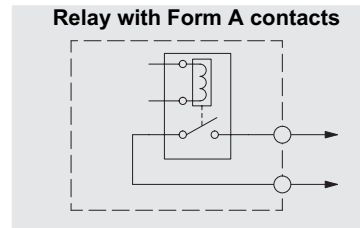

Relay Outputs - Transient Suppression for Inductive Loads in a Control System

The following pages are intended to give a quick overview of the negative effects of transient voltages on a control system and provide some simple advice on how to effectively minimize them. The need for transient suppression is often not apparent to the newcomers in the automation world. Many mysterious errors that can afflict an installation can be traced back to a lack of transient suppression.

What is a Transient Voltage and Why is it Bad?

Inductive loads (devices with a coil) generate transient voltages as they transition from being energized to being de-energized. If not suppressed, the transient can be many times greater than the voltage applied to the coil. These transient voltages can damage PLC outputs or other electronic devices connected to the circuit, and cause unreliable operation of other electronics in the general area. Transients must be managed with suppressors for long component life and reliable operation of the control system.

This example shows a simple circuit with a small 24V/125mA/3W relay. As you can see, when the switch is opened, thereby de-energizing the coil, the transient voltage generated across the switch contacts peaks at 140V.

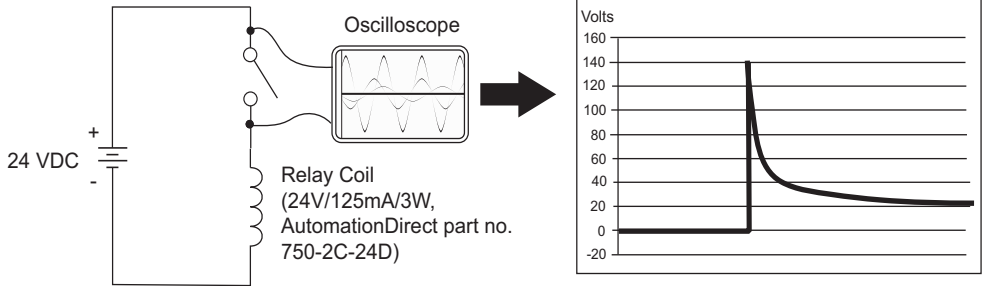
Example: Circuit with no Suppression

In the same circuit, replacing the relay with a larger 24V/290mA/7W relay will generate a transient voltage exceeding 800V (not shown). Transient voltages like this can cause many problems, including:

- Relay contacts driving the coil may experience arcing, which can pit the contacts and reduce the relay's lifespan.
- Solid state (transistor) outputs driving the coil can be damaged if the transient voltage exceeds the transistor's ratings. In extreme cases, complete failure of the output can occur the very first time a coil is de-energized.
- Input circuits, which might be connected to monitor the coil or the output driver, can also be damaged by the transient voltage.

A very destructive side-effect of the arcing across relay contacts is the electromagnetic interference (EMI) it can cause. This occurs because the arcing causes a current surge, which releases RF energy. The entire length of wire between the relay contacts, the coil, and the power source carries the current surge and becomes an antenna that radiates the RF energy. It will readily couple into parallel wiring and may disrupt the PLC and other electronics in the area. This EMI can make an otherwise stable control system behave unpredictably at times.

PLC's Integrated Transient Suppressors

Although the PLC's outputs typically have integrated suppressors to protect against transients, they are not capable of handling them all. It is usually necessary to have some additional transient suppression for an inductive load.

The next example uses the same 24V/125mA/3W relay used earlier. This example measures the PNP transistor output of a D0-06DD2 PLC, which incorporates an integrated Zener diode for transient suppression. Instead of the 140V peak in the first example, the transient voltage here is limited to about 40V by the Zener diode. While the PLC will probably tolerate repeated transients in this range for some time, the 40V is still beyond the module's peak output voltage rating of 30V.

Example: Small Inductive Load with Only Integrated Suppression

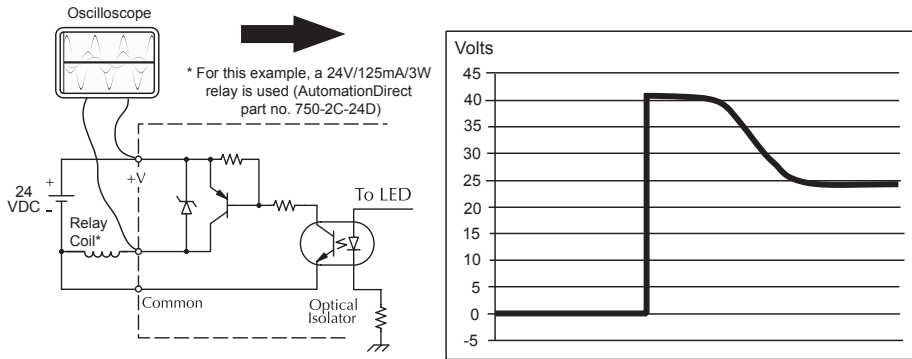

The next example uses the same circuit as above, but with a larger 24V/290mA/7W relay, thereby creating a larger inductive load. As you can see, the transient voltage generated is much worse, peaking at over 50V. Driving an inductive load of this size without additional transient suppression is very likely to permanently damage the PLC output.

Example: Larger Inductive Load with Only Integrated Suppression

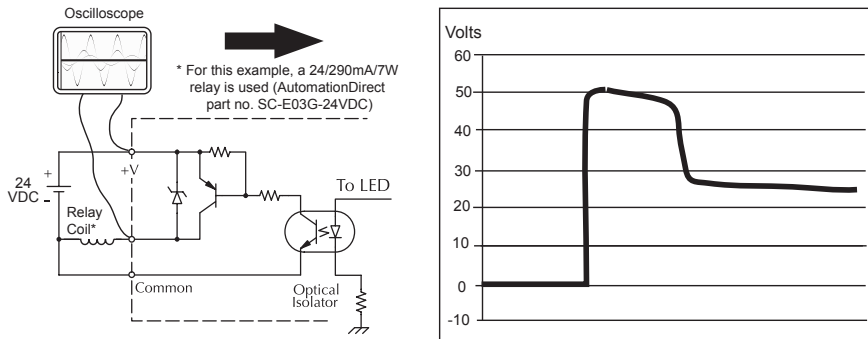

Additional transient suppression should be used in both these examples. If you are unable to measure the transients generated by the connected loads of your control system, using additional transient suppression on all inductive loads would be the safest practice.

Types of Additional Transient Protection

DC Coils:

The most effective protection against transients from a DC coil is a flyback diode. A flyback diode can reduce the transient to roughly 1V over the supply voltage, as shown in this example.

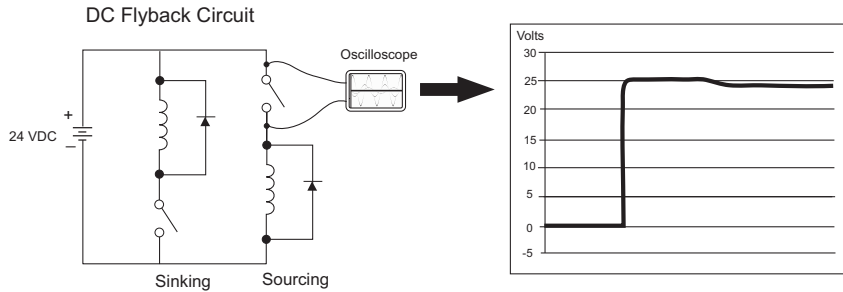

Many AutomationDirect socketed relays and motor starters have add-on flyback diodes that plug or screw into the base, such as the AD-ASMD-250 protection diode module and 784-4C-SKT-1 socket module shown below. If an add-on flyback diode is not available for your inductive load, an easy way to add one is to use AutomationDirect's DN-D10DR-A diode terminal block, a 600VDC power diode mounted in a slim DIN rail housing.



AD-ASMD-250
Protection Diode Module



784-4C-SKT-1
Relay Socket

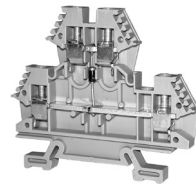

DN-D10DR-A
Diode Terminal Block

Two more common options for DC coils are Metal Oxide Varistors (MOV) or TVS diodes. These devices should be connected across the driver (PLC output) for best protection as shown below. The optimum voltage rating for the suppressor is the lowest rated voltage available that will NOT conduct at the supply voltage, while allowing a safe margin.

AutomationDirect's ZL-TSD8-24 transorb module is a good choice for 24VDC circuits. It is a bank of 8 uni-directional 30V TVS diodes. Since they are uni-directional, be sure to observe the polarity during installation. MOVs or bi-directional TVS diodes would install at the same location, but have no polarity concerns.



DC MOV or TVS Diode Circuit

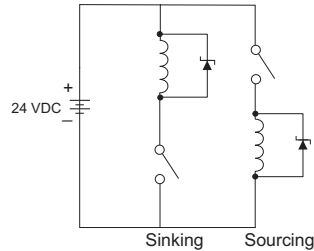

AC Coils:

Two options for AC coils are MOVs or bi-directional TVS diodes. These devices are most effective at protecting the driver from a transient voltage when connected across the driver (PLC output) but are also commonly connected across the coil. The optimum voltage rating for the suppressor is the lowest rated voltage available that will NOT conduct at the supply voltage, while allowing a safe margin.

The AutomationDirect ZL-TSD8-120 transorb module is a good choice for 120VAC circuits. It is a bank of eight bi-directional 180V TVS diodes.



AC MOV or Bi-Directional Diode Circuit

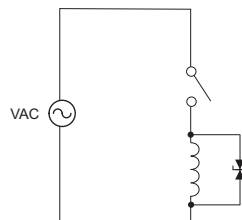

NOTE: Manufacturers of devices with coils frequently offer MOV or TVS diode suppressors as an add-on option which mount conveniently across the coil. Before using them, carefully check the suppressor ratings. Just because the suppressor is made specifically for that part does not mean it will reduce the transient voltages to an acceptable level.

For example, a MOV or TVS diode rated for use on 24–48VDC coils would need to have a high enough voltage rating to NOT conduct at 48V. That suppressor might typically start conducting at roughly 60VDC. If it were mounted across a 24V coil, transients of roughly 84V (if sinking output) or -60V (if sourcing output) could reach the PLC output. Many semiconductor PLC outputs cannot tolerate such levels.

I/O Modules Position, Wiring and Specifications

Multiple Power Supply Configuration

It is possible to have multiple power supplies in a single slave (node) system to meet power budget requirements. **One power supply is required in the leftmost component position followed by the base controller.** Additional power supplies should be added between I/O modules as necessary to meet power budget requirements (there are some restrictions on where power supplies can be placed in the system when using the T1K-05CBL-RR(-1) expansion base cable). Each power supply powers the modules to its right, but is interrupted by the next power supply. Each slave (node) system can be divided into one row of base I/O plus two rows of local expansion I/O up to a total of 16 I/O modules.

Expansion cables are available in two configurations: one that passes 24VDC base power through and one that does not (both cables pass the 5VDC base power). The (-1) version of the expansion cables pass 24VDC through on an isolated wire. Any local expansion DC input modules configured for internal power (current sourcing) must either have a power supply preceding it on the same base or, have a (-1) version cable to pass 24VDC from a power supply on the preceding base.



NOTE: *The T1K-05CBL-RR-1 expansion cable with an isolated 24VDC lead was discontinued in 2015 and is no longer available. Some of the following examples show this cable. As an alternative consider using the T1K-10CBL-1 cable as shown in the first example on the following page. See the Multiple Power Supplies / Local Expansion Configurations section in Chapter 2 for more information.*

Overview of I/O Expansion Configurations

There are several expansion I/O system configurations that can be created by using the local expansion cables. There are some restrictions on where power supplies can be placed in the system when using the T1K-05CBL-RR-1 expansion base cable. Refer to Chapter 2 for details of the example systems shown below.

**One expansion cable each;
T1K-10CBL and T1K-10CBL-1**

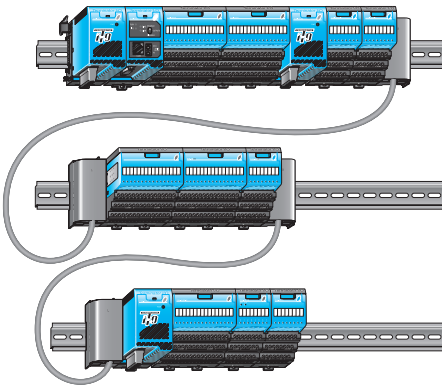

**One expansion cable each;
T1K-05CBL-RR-1 and T1K-05CBL-LL**

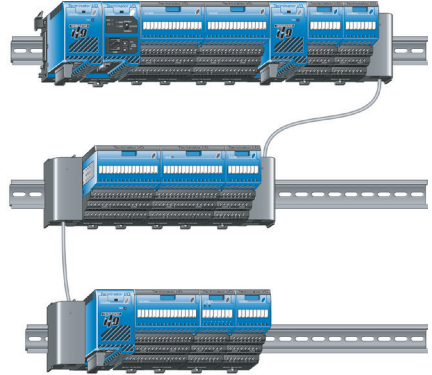

**One expansion cable each;
T1K-10CBL-1 and T1K-05CBL-RR-1**

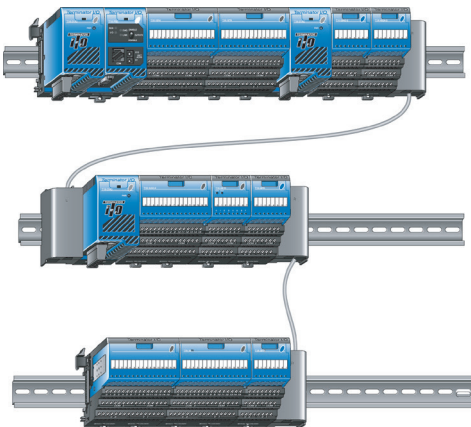

T1K-05CBL-RR-1 Expansion Cable

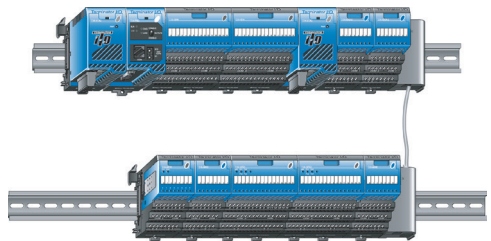

Types of Modules Available for the Terminator System

The table below lists the type of modules are available for the Terminator by category.

Terminator I/O Module / Unit	Slave System
Base Controller	Only one per slave (node) system. Mount to the right of the first power supply.
Additional Power Supplies	Yes (see Note)
DC Input Modules	Yes
AC Input Modules	Yes
DC Output Modules	Yes
AC Output Modules	Yes
Relay Output Modules	Yes
Analog Modules (volt, current, temp)	Yes
CTRIO Counter I/O Modules	Yes



NOTE: One power supply is required in the leftmost component position followed by the Base Controller. Additional power supplies should be added between I/O modules as necessary to meet power budget requirements. Each power supply powers the modules to its right, but is interrupted by the next power supply. It is not mandatory to have a power supply in the leftmost position on an expansion rack. Expansion cables are available in two configurations: one that passes 24VDC base power through and one that does not.

Discrete Module Status Indicators

The discrete I/O modules provide LED status indicators to show the status of the I/O points. Most of the output modules have additional LEDs to indicate a blown fuse.

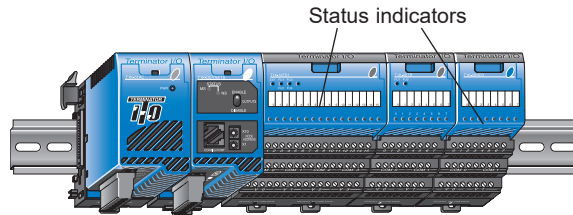

Color Coding of I/O Modules

The Terminator I/O family of I/O modules have a color coding scheme to help you quickly identify the module as either a power supply, an input module or an output module. This is done through a color mark indicator located on the front of each module. The color scheme is shown in the diagram and table on the following page.

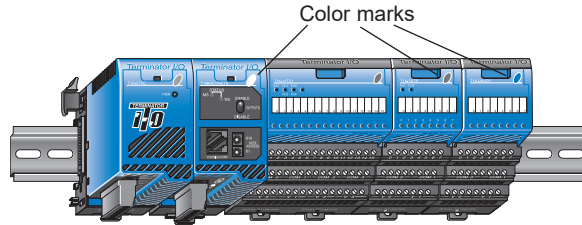

Module Type	Color Code
Power Supply	Green
Base Controller / Specialty	White
Discrete / Analog Input	Blue
Discrete / Analog Output	Red

Wiring the I/O Module Bases

There are two types of terminal bases for the Terminator I/O modules: screw clamp and spring clamp connectors. The recessed screw heads help minimize the risk of someone accidentally touching active wiring.



WARNING: For some modules, field device power may still be present on the terminal block even though the Terminator I/O system power is turned off. To minimize the risk of electrical shock, check all field device power before you remove a wire.

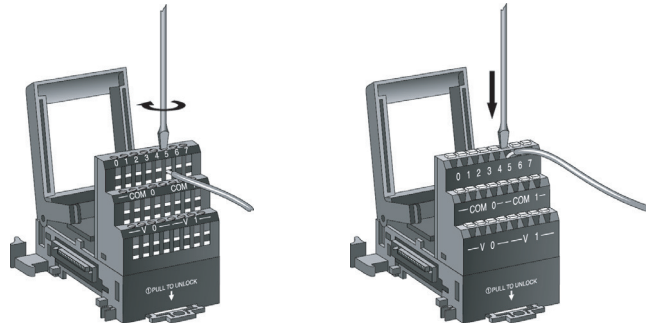

Terminal Type	Screw Type	Spring Clamp
Recommended Torque	1.77–3.54 lb·in (0.2–0.4 N·m)	-
Recommended Screwdriver Blade Size	0.02 in. x 0.125 in. (0.5 mm x 3mm)	Push in on clamp using screwdriver blade size: (0.016 x 0.079 to 0.032 x 0.16) in. (0.4 x 2 to 0.8 x 4) mm
Wire Gauge	Solid conductor: 24–12 AWG Stranded conductor: 24–12 AWG	Solid conductor: 24–14 AWG Stranded conductor: 24–14 AWG (Twist conductors before inserting into gate)

Selecting Internal 24VDC Power Supply

The DC input field devices can be powered from the integrated 24VDC power supply from the power supply bus. The T1K-08ND3 and T1K-16ND3 DC input modules have jumpers for selecting internal 24VDC power supply available for 2 and 3-wire field devices. The analog I/O and DC output modules do not have direct access to the internal bussed 24VDC.

Jumpers located under top cover of T1K-08ND3 and T1K-16ND3

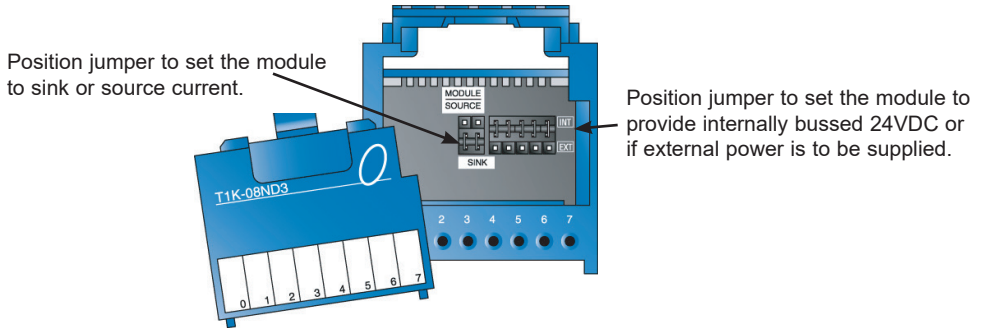

Using Internal 24VDC Base Power

The diagram below shows DC input devices using internally bussed 24VDC for power. If the module is set to “sink” current, +24VDC power is supplied to the input module base “COM” terminals and 0VDC is supplied to the module base “V” terminals. If the module is set to “source” current, +24VDC is supplied to the input module base “V” terminals and 0VDC is supplied to the module base “COM” terminals.

Using Internally Bussed 24VDC (T1K-08ND3, T1K-16ND3 only)

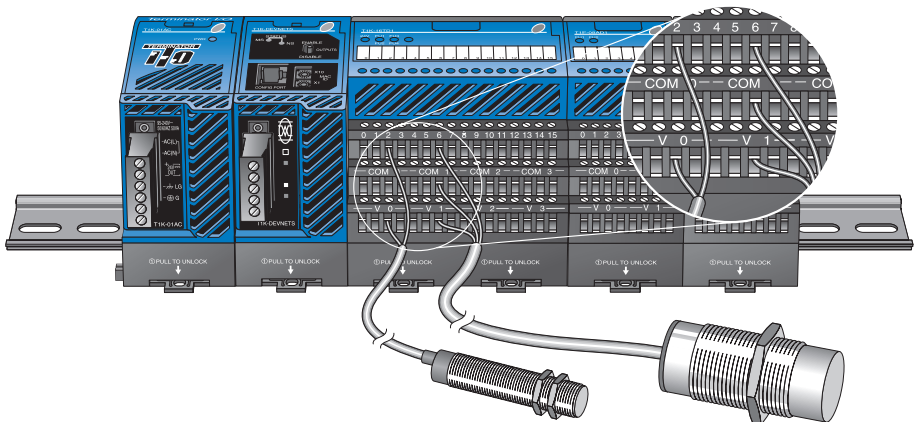

2 and 3-wire input field devices

External 24VDC Wiring Options

DC output and analog I/O modules do not have direct access to the internally bussed 24VDC. External user supplied 24VDC power, or auxiliary 24VDC from the T1K-01AC, can be applied directly to one end of the DC I/O module base terminal (V and COM) rows and jumpered across each base as needed in a system. This creates a “bus” (row) of 24VDC and a bus of 0VDC power. Be sure not to exceed the supply power budget.



NOTE: If you intend to use the I/O module Hot Swap feature, refer to the *Check External 24VDC Wiring Before Hot Swapping* section on page 3-17. The external 24VDC wiring options below are not recommended when intending to Hot Swap DC output or analog I/O modules.

Using T1K-01AC for External 24VDC Power

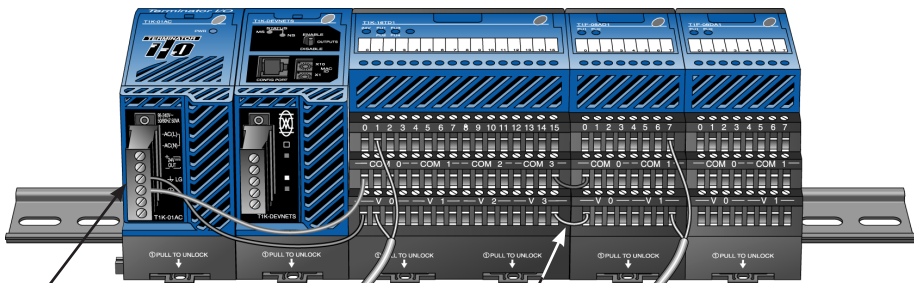

Use T1K-01AC external 24VDC to create a power bus for DC modules.

Place wire jumpers from one DC I/O module base to another as necessary to continue the external 24VDC power bus.

Using an External 24VDC Power Supply

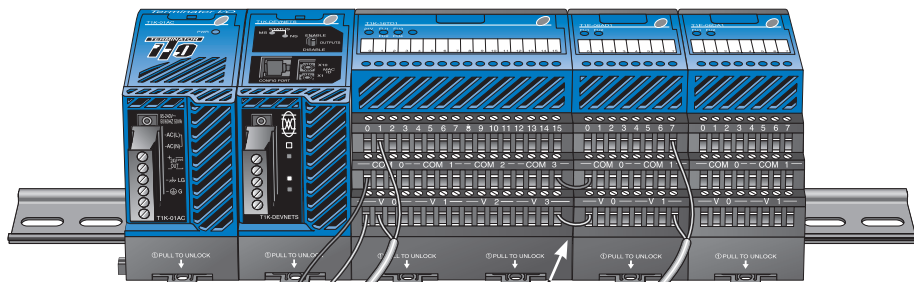

Use an external 24VDC power supply to create a power bus for the DC modules.

Place wire jumpers from one DC I/O module base to another as necessary to continue the external 24VDC power bus.

I/O Wiring Checklist

Use the following guidelines when wiring the base terminals in your system.

- 1. There is a limit to the size of wire the terminals can accept. The table below lists the suggested AWG for each module type.
- 2. Always use a continuous length of wire, do not combine wires to attain a needed length.
- 3. Use the shortest possible wire length.
- 4. Use wire trays for routing where possible.
- 5. Avoid running wires near high-energy wiring.
- 6. Avoid running input wiring close to output wiring where possible.
- 7. To minimize voltage drops when wires must run a long distance, consider using multiple wires for the return line.
- 8. Avoid running DC wiring in close proximity to AC wiring where possible.
- 9. Avoid creating sharp bends in the wires.
- 10. To reduce the risk of having a module with a blown fuse, we suggest you add external fuses to your I/O wiring. A fast blow fuse, with a lower current rating than the I/O module fuse can be added to each common, or a fuse with a rating of slightly less than the maximum current per output point can be added to each output.

Output Module Fusing

All Terminator I/O discrete output modules have internal user-replaceable fuses. For fuse specifications and part numbers for a specific output module, refer to the output module specifications later in this chapter. Be sure to remove system power or disable outputs via the Base Controller switch before attempting to remove the I/O module from its base. Refer to the next section “I/O Module Hot Swap Feature” if attempting to remove an I/O module with the system power ON.

Fuses located under top cover of output modules

Note: A blown fuse indicator illuminates only when a fuse is blown and associated output point is turned ON by the program.

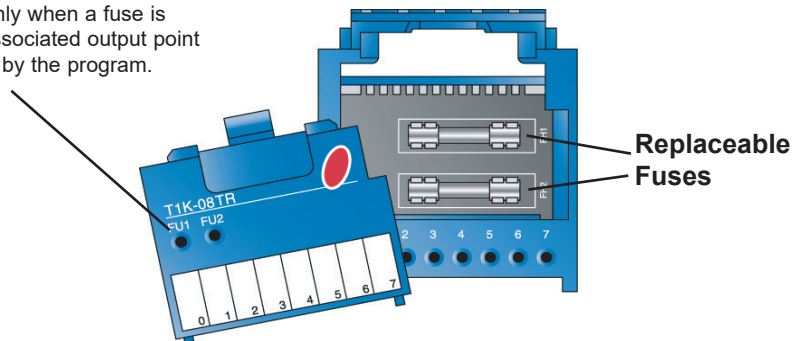

I/O Module Hot Swap Feature

The “Hot Swap” feature allows Terminator I/O modules to be replaced with Terminator I/O system power ON. Be careful not to touch the terminals with your hands or any conductive material to avoid the risk of personal injury or equipment damaged. Always remove power if it is equally convenient to do so.



WARNING: Only authorized personnel fully familiar with all aspects of the application should replace an I/O module with system power ON.

The Base Controllers in the table at right support the “Hot Swap” feature.

Base Controller	Supports “Hot Swap”
T1K-DEVNETS	Yes
T1K-MODBUS	Yes
T1K-RSSS	Yes
T1H-EBC(100)	Yes (refer to T1H-EBC-M or T1H-PBC-M User Manual for “Hot Swap” information)
T1H-PBC*	



**Note: T1H-PBC was discontinued 8/2020; no replacement available.*

The table at right shows which modules can or cannot be “Hot Swapped”.

Module	Can be “Hot Swapped”
Power Supply	No
Base Controller	No
I/O Modules (discrete / analog)	Yes

Hot Swap: I/O Module Replacement

The following steps explain how to “Hot Swap” an I/O module.

1. Remove I/O module from base.
2. Install new I/O module of the same part number.
3. Verify that the Base Controller LEDs have returned to normal.

Outputs Enable / Disable Switch

A feature that may be used in a non-continuous process application is the Outputs Enable/Disable switch. The switch is located on the front of the T1K-(DEVNETS, MODBUS, RSSS) base controllers. When the switch is in the Disable position all outputs are disabled (OFF), although discrete and analog input data continues to be read. This option may be used at a convenient time during the process application to replace an I/O module.

Check External 24VDC Wiring Before Hot Swapping

Before “Hot Swapping” an analog I/O module or a DC output module in a Terminator I/O system, make sure that each of the analog I/O and DC output module’s 24VDC and 0VDC base terminals are wired directly to the external power supply individually (see diagram below). If the external 24VDC / 0VDC is jumpered from base to base in a daisy chain fashion, and an analog I/O or DC output module is removed from its base, the risk of disconnecting the external 24VDC to the subsequent I/O modules exists.

Wire each analog or DC output module independently to the external power supply.



Do not jumper modules together creating 24VDC bus for Hot Swap.

Calculating the Power Budget

Managing the Power Resource

When determining the types and quantity of I/O modules to be used in the Terminator I/O system, it is important to remember there is a limited amount of power available from the power supply. A chart is provided to help you easily see the amount of power available with AC and DC power supplies. At the end of this section you will also find an example of power budgeting and a worksheet showing sample calculations.

If the chosen I/O exceeds the maximum power available from the power supply the problem is corrected by simply adding another power supply .



WARNING: It is extremely important to calculate the power budget correctly. If you exceed the power budget, the system may operate in an unpredictable manner which may result in a risk of personal injury or equipment damage.

Power Supply Specifications

The following chart shows the amount of current **supplied** by the Terminator I/O power supply. Use this to calculate the power budget for your system. The Auxiliary 24V Power Source mentioned in the table can be used to power field devices or modules that require an external 24VDC.

AC Power Supply	5VDC Current Supplied in mA (internal)	Auxiliary 24VDC Power Source Current Supplied in mA	DC Power Supply	5VDC Current Supplied in mA (internal)	Auxiliary 24VDC Power Source Current Supplied in mA
T1K-01AC	2000	300	T1K-01DC	2000	N/A
A max. of 500mA @ 24VDC can be achieved by lowering the 5VDC to 1500mA	1500	500	N/A	N/A	N/A

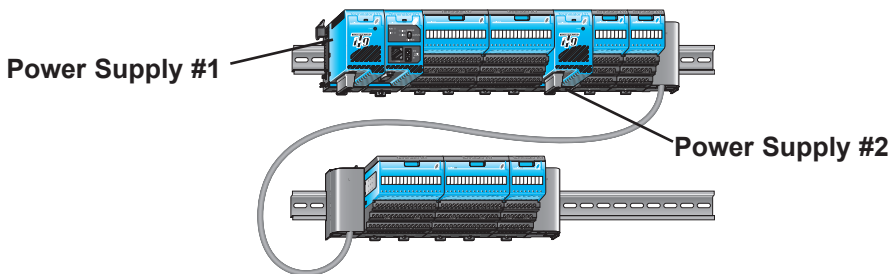

NOTE: Important about Power Supplies - One power supply is required in the leftmost component position (Power Supply #1), as shown above. Additional power supplies should be added between I/O modules as necessary to meet power budget requirements. Each power supply powers the modules to its right, but is interrupted by the next power supply. It is not mandatory to have a power supply in the leftmost position on an expansion rack.

The system shown above: The first Power Supply (PS#1) powers the network interface module and the two I/O modules to its right. The second Power Supply (PS#2) powers the remaining five I/O modules. This is only an example and the power budget requirements vary depending on the I/O modules used.



Module Power Requirements

This chart shows the amount of maximum current *required* for each of the Terminator I/O modules. Use this information to calculate the power budget for your system. If an external 24VDC power source is required, you can use the built-in 24VDC auxiliary supply as long as you do not exceed the power budget. If any device is connected to the Controller's serial port that uses the 5VDC supply pin, be sure to include the device's power consumption in your 5VDC power budget calculation.

Base Controller and I/O Module Power Consumption					
Module	5VDC (mA)	24VDC (mA)	Module	5VDC (mA)	24VDC (mA)
Base Controllers			AC Output Module		
T1K-RSSS	250	0	T1K-08TA	250	0
T1K-DEVNETS	190	(See note 1)	T1K-16TA	450	0
T1H-EBC(100)	350	0	T1K-08TAS	300	0
T1K-MOVBUS	250	0	Relay Output Modules		
T1H-PBC	530	0	T1K-08TR	350	0
DC Input Modules			T1K-16TR	700	0
T1K-08ND3	35	0	T1K-08TRS	400	0
T1K-16ND3	70	0	Analog Input Modules		
AC Input Modules			T1F-08AD-1	75	50 (see note 2)
T1K-08NA-1	35	0	T1F-16AD-1	75	50 (see note 2)
T1K-16NA-1	70	0	T1F-08AD-2	75	50 (see note 2)
DC Output Modules			T1F-16AD-2	75	50 (see note 2)
T1K-08TD1	100	200 (see note 2)	T1F-16RTD	150	0
T1K-08TD2-1	100	0	T1F-16TMST	150	0
T1H-08TDS	200	0	T1F-14THM	60	70 (see note 2)
T1K-16TD1	200	400 (see note 2)	Analog Output Modules		
T1K-16TD2-1	200	0	T1F-08DA-1	75	150 (see note 2)
Combination Analog Modules			T1F-16DA-1	75	150 (see note 2)
T1F-8AD4DA-1	75	60 (see note 2 and 3)	T1F-08DA-2	75	150 (see note 2)
T1F-8AD4DA-2	75	70 (see note 2)	T1F-16DA-2	75	150 (see note 2)
			Specialty Modules and other devices (see note 4)		
			T1H-CTRIO	400	0

Note 1: The T1K-DEVNETS consumes 45mA @ 11–25 VDC from the DeviceNet System.

Note 2: Use T1K-01AC 24VDC auxiliary supply or external user supply.

Note 3: 60mA plus 20mA per output loop

Note 4: If any device is connected to the Controller's serial port that uses the 5VDC supply pin, be sure to include the device's power consumption in your 5VDC power budget calculation



NOTE: Important Power Budget - For each power supply in a system, make sure the current required by the interface and I/O modules does not exceed the current supplied at both 5VDC and 24VDC.

Power Budget Calculation Example

The following example shows how to calculate the power budget for the first slave unit of an I/O system.

SLAVE (Node) #1			
Power Supply #1	Part Number	5VDC (mA) Required	24VDC (mA) Required
Power Supplied T1K-01AC (see pg. 3-19)		2000	300
Slave	T1H-EBC100	350	0
Module	T1K-16NA-1	70	0
Module	T1K-16TA	450	0
Other (I/O, etc.)	-	0	0
Maximum power required		870	0
Remaining power available		2000-870 = 1130	300-0 = 300
Power Supply #2	Part Number	5VDC (mA) Required	24VDC (mA) Required
Power Supplied T1K-01AC (see pg. 3-19)		1500	500
Module	T1K-08AD-2	75	50
Module	T1K-08AD-2	75	50
Module	T1K-16TD1	200	400
Module	T1K-08TR	350	0
Module	T1K-08ND3	35	0
Other	-	0	0
Maximum power required		735	500
Remaining power available		1500-735 = 765	500-500 = 0 (see note 1)

Note 1: An external user power supply must be used in if the 24VDC current requirement exceeds the T1K-01AC 24VDC auxiliary supply.

1. When using the tables at the beginning of the Power Budgeting section of this chapter, fill in the information for the base controller, I/O modules, and any other devices that will use system power, including devices that use the 24VDC output. Devices which fall into the “Other” category are devices such as an operator interface which also has power requirements but do attach as a module to the system.
2. Add the current columns starting with the slave and put the total in the row labeled “Maximum power required”.
3. Subtract the row labeled “Maximum power required” from the “Power Supplied”. Place the difference in the row labeled “Remaining Power Available”.
4. If “Maximum Power Required” is greater than “Power Supplied” in either of the two columns, the power budget will be exceeded. It will be unsafe to use this configuration and you will need to restructure your I/O configuration.

I/O Specification Terms

Inputs or Outputs Per Module

Indicates number of input or output points per module and designates current sinking, current sourcing, or either.

Commons Per Module

Number of commons per module and their electrical characteristics.

Input Voltage Range

The operating voltage range of the input circuit.

Output Voltage Range

The operating voltage range of the output circuit.

Peak Voltage

Maximum voltage allowed for the input circuit.

AC Frequency

AC modules are designed to operate within a specific frequency range.

ON Voltage Level

The voltage level at which the input point will turn ON.

OFF Voltage Level

The voltage level at which the input point will turn OFF.

Input impedance

Input impedance can be used to calculate input current for a particular operating voltage.

Input Current

Typical operating current for an active (ON) input.

Minimum ON Current

The minimum current for the input circuit to operate reliably in the ON state.

Maximum OFF Current

The maximum current for the input circuit to operate reliably in the OFF state.

Minimum Load

The minimum load current for the output circuit to operate properly.

External DC Required

Some output modules require external power for the output circuitry.

ON Voltage Drop

Sometimes called “saturation voltage”, it is the voltage measured from an output point to its common terminal when the output is ON at maximum load.

Maximum Leakage Current

The maximum current a connected maximum load will receive when the output point is OFF.

Maximum Inrush Current

The maximum current used by a load for a short duration upon an OFF to ON transition of a output point. It is greater than the normal ON state current and is characteristic of inductive loads in AC circuits.

Base Power Required

Power from the base power supply is used by the Terminator I/O modules and varies between different modules. The guidelines for using module power is explained in the power budget section of this manual.

OFF to ON Response

The time the module requires to process an OFF to ON state transition.

ON to OFF Response

The time the module requires to process an ON to OFF state transition.

Terminal Type

Indicates whether the terminal type is a removable or non-removable connector or a terminal.

Status Indicators

The LEDs that indicate the ON/OFF status of an input point. These LEDs are electrically located on either the logic side or the field device side of the input circuit.

Weight

Indicates the weight of the module.

Fuses

Protective devices for an output circuit, which stop current flow when current exceeds the fuse rating. They may be replaceable or non-replaceable, or located externally or internally.

T1K-01AC, T1K-01DC Power Supply

Specifications		
Specification	T1K-01AC	T1K-01DC
Input Voltage Range	110/220 VAC (85–264 VAC)	12/24 VDC (10.8 - 26.4 VDC)
Input Frequency	50/60 Hz (47–63 Hz)	-
Maximum Power	50VA	20W
Maximum Inrush Current	20A	10A
Insulation Resistance	> 10M Ω @ 500VDC	
Voltage Withstand (Dielectric)	1 min. @ 1500VAC between primary, secondary and field ground	
Auxiliary 24VDC Supply	300mA maximum	-
Output 1: 5VDC Base Power Supplied	Voltage	5.25 VDC (5.00–5.50 VDC)
	Current	a) 2.0 A maximum b) 1.5 A maximum (see note)
	Ripple	5% maximum
Output 2: 24VDC Base Power Supplied	Voltage	24VDC (20.0–28.0 VDC)
	Current	a) 300mA maximum b) 500mA maximum (see note)
	Ripple	10% maximum
Replacement Terminal Block - Phoenix Contact	MVSTBW 2.5/4-ST-5.08 BK	MVSTBW 2.5/6-ST-5.08 BK
Fuse	1 (Primary) not replaceable	



NOTE: 500mA @ 24VDC is achieved by lowering the 5VDC to 1.5 A from 2.0 A.

Environmental Specifications	
Ambient Operating Temperature	32°F to 131°F (0°C to 55°C)
Storage Temperature	-4°F to 158°F (-20°C to 70°C)
Ambient Humidity	5% to 95% (Non-condensing)
Atmosphere	No corrosive gases. The level of environmental pollution = 2 (UL 840).
Vibration Resistance	MIL STD 810C. Method 514.2
Shock Resistance	MIL STD 810C. Method 514.2
Voltage Withstand	1500VAC, 1 minute
Insulation Resistance	500VDC, 10M Ω
Noise Immunity	NEMA ICS3-304 Impulse Noise 1 μ s, 1000V FCC class A RFI (144MHz, 430MHz 10W, 10cm)

Dimensions

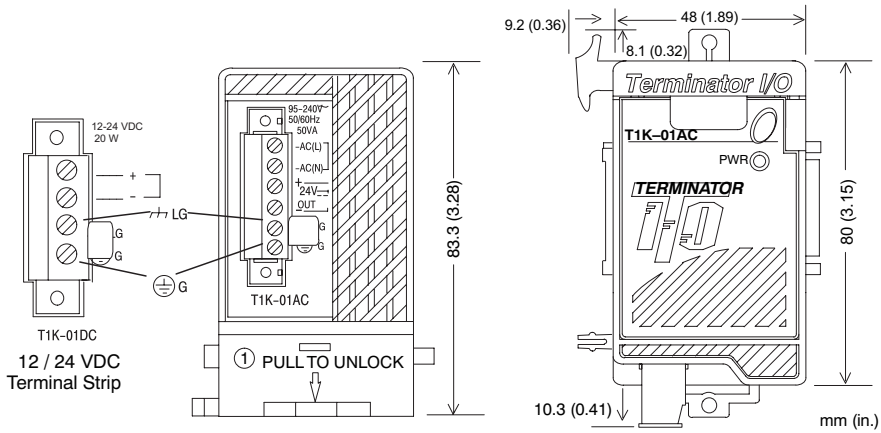

Power Supply #1

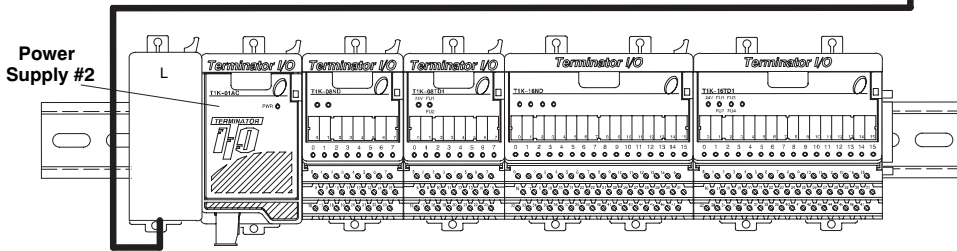
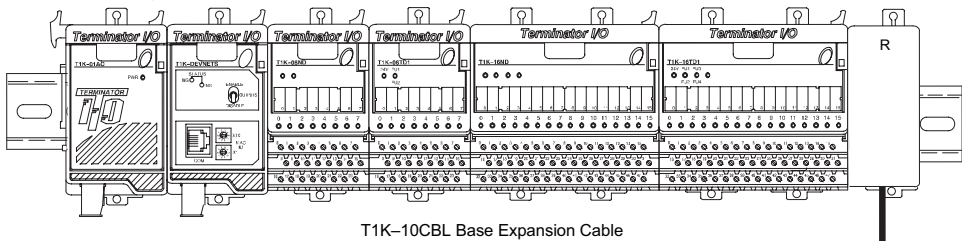

Note 1: The T1K-DEVNETS consumes 45 mA @ 11-25 VDC from the DeviceNet System

Note 2: Use T1K-01AC 24 VDC auxiliary supply or external user supply

Important Power Budget Note: For each power supply in a system, make sure the current required by the interface and I/O modules does not exceed the current supplied at both 5 VDC and 24 VDC.

T1H-EBC Ethernet Base Controller (Obsoleted)



*Note: T1H-EBC was discontinued 08/2011; no replacement available.

Specifications	
Module Type	Ethernet Slave
Communications	10Base-T
Auto-configuring	I/O type/position automatically identified during power-up
Ethernet Protocols	UDP/IP, IDX
Ethernet Port	RJ-45
Node Address	1 to 99 (decimal) set by rotary switches or software (0 used for setting address via software only)
Link Distance	100 meters (328 feet)
Data Transfer Rate	10Mbps
LED Indicators	<p>MODULE GOOD (green) On = module passed diagnostics check during last power-up Fast Blink = Configured I/O module no longer reporting (see auto-configuring above) Slow Blink = Unconfigured I/O module added to system (see auto-configuring above)</p> <p>LINK GOOD (green) On = 10Base-T link pulses are being received</p> <p>ACTIVITY (red) On = Ethernet network activity detected</p> <p>ERROR (red) On = Watchdog timer timeout represents hardware, communications or network fault; power-on reset or reset within master device software</p>
NOTE: All indicators re-initialize during power-up. For more information consult the T1H-EBC-M User Manual.	
Communications Port	RJ-12, RS-232C K-Sequence protocol, ASCII (not functional when used with H2-ERM).
Base Power Requirements	350mA @ 5VDC (EBC); Serial port supports up to 500mA @ 5VDC (Add for power budget consumption).

General Specifications	
Installation Requirements	Mounts to the right of the first power supply.
Operating Temperature	32°F to 131°F (0°C to 55°C)
Storage Temperature	-4°F to 158°F (-20°C to 70°C)
Relative Humidity	5% to 95% (Non-condensing)
Environmental Air	No corrosive gases. The level of environmental pollution = 2 (UL 840).
Vibration	MIL STD 810C. Method 514.2
Shock	MIL STD 810C. Method 514.2
Noise Immunity	NEMA ICS3-304 Impulse Noise 1 μ s, 1000V FCC class A RFI (144MHz, 430MHz 10W, 10cm)

Dimensions

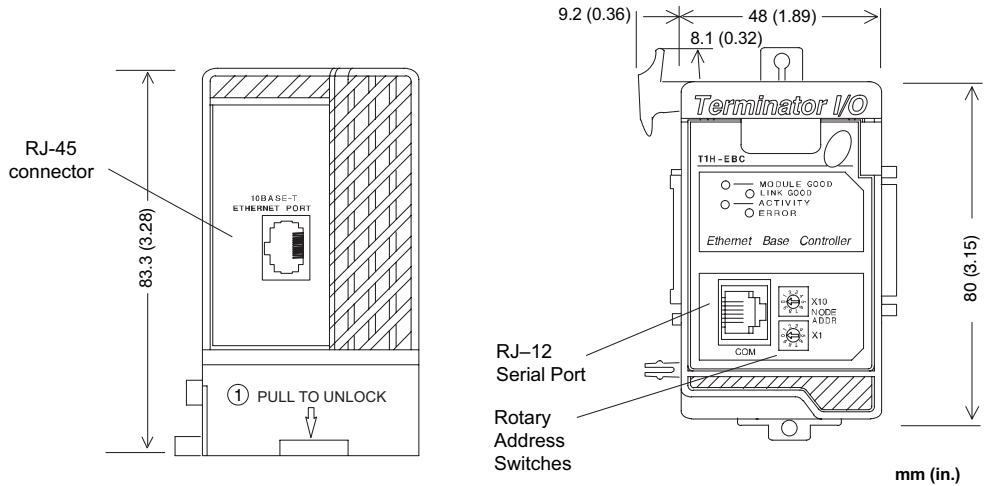

T1K-EBC Ethernet Port Pin-out

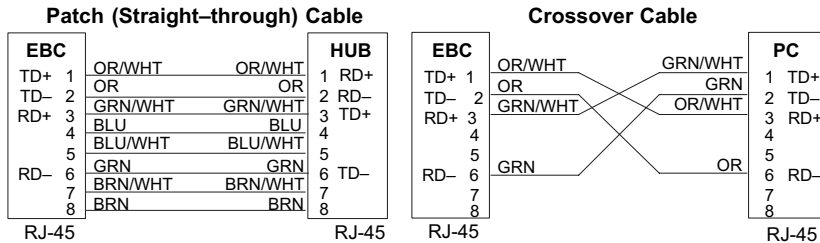

This diagram illustrates the standard wire positions in the RJ-45 connector. We strongly recommend that you use Category 5 or better, UTP cable.

T1K-EBC Serial Port Pin-out

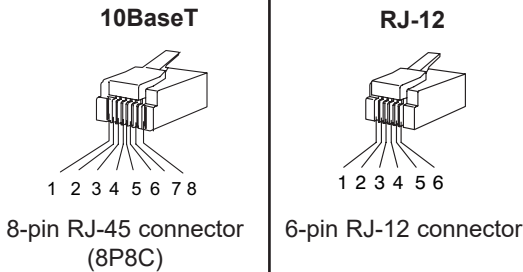

Serial Port Pin Descriptions		
Pin	Signal	Definition
1	0V	Power (+) connection (GND)
2	5V	Power (+) connection
3	RXD	Receive Data (RS-232C)
4	TXD	Transmit Data (RS-232C)
5	5V	Request to send
6	0V	Clear to Send

T1H-EBC100 Ethernet Base Controller

Specifications	
Module Type	Ethernet Slave
Communications	100Base-T Ethernet
Auto-configuring	I/O type/position automatically identified during power-up
IP Configuration	Obtain an IP address from a DHCP Server automatically at power-up (Default); Dedicated IP address using NetEdit3 or HTML configuration.
Ethernet Protocols	UDP/IP, IPX, MODBUS TCP
Ethernet Port	RJ-45
Node Address	1 to 99 (decimal) set by rotary switches or software; 0 (default, used for setting address via software only)
Link Distance	100 meters (328 feet)
Data Transfer Rate	100 MBaud or 10 MBaud (auto-detect)
LED Indicators	<p>MODULE GOOD (green): On = module passed diagnostics check during last power-up Fast Blink = configured I/O module no longer reporting (see auto-configuring above) Slow Blink = Unconfigured I/O module added to system (see auto-configuring above)</p> <p>LINK / ACTIVITY (green): On = Ethernet network activity detected</p> <p>100 MBit (green): On = Ethernet network activity detected at 100 Mbps Off = (With LINK / ACTIVITY On) Ethernet activity is auto-detected at 10 Mbps</p> <p>ERROR (red) On = watchdog timer timeout represents hardware, communications or network fault; power-on reset or reset within master device software</p> <p>SERIAL TX (green): On = EBC RJ12 serial port is transmitting</p> <p>SERIAL RX (green): On = EBC RJ12 serial port is receiving</p>
Serial Communications Port	RJ-12, RS-232C K-Sequence protocol, ASCII, MODBUS RTU [not functional when used with H2-ERM(100), H4-ERM(100), or H2-DM1(E)].
Base Power Requirement	350mA @ 5VDC (EBC); Serial port supports up to 500mA @ 5VDC (add for power budget consumption).

General Specifications	
Installation Requirements	Mounts to the right of the first power supply.
Operating Temperature	32°F to 131°F (0°C to 55°C)
Storage Temperature	-4°F to 158°F (-20°C to 70°C)
Relative Humidity	5% to 95% (Non-condensing)
Environmental Air	No corrosive gases. The level of environmental pollution = 2 (UL 840).
Vibration	MIL STD 810C. Method 514.2
Shock	MIL STD 810C. Method 514.2
Noise Immunity	NEMA ICS3-304 Impulse Noise 1 μ s, 1000V FCC class A RFI (144MHz, 430MHz 10W, 10cm)

Dimensions

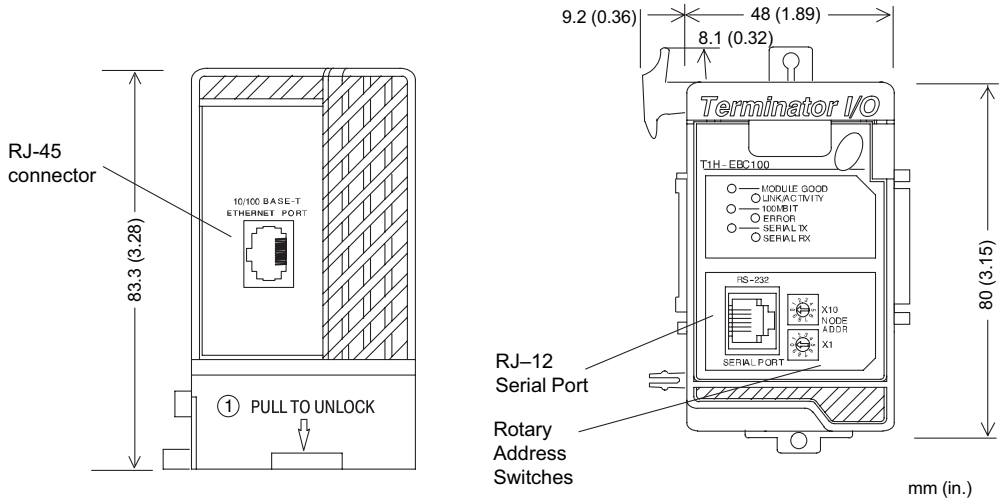

T1K-EBC100 Ethernet Port Pin-out

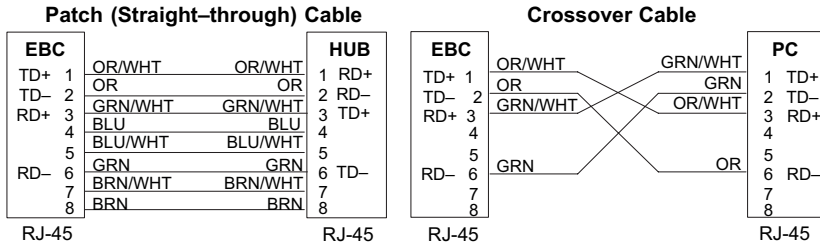

This diagram illustrates the standard wire positions in the RJ-45 connector. We strongly recommend that you use Category 5 or better, UTP cable.

T1K-EBC100 Serial Port Pin-out

10 / 100BaseT

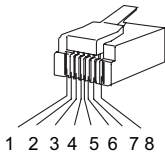

8-pin RJ-45 connector (8P8C)

RJ-12

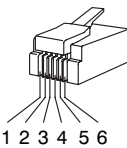

6-pin RJ-12 connector

Serial Port Pin Descriptions		
Pin	Signal	Definition
1	0V	Power (-) connection (GND)
2	5V	Power (+) connection
3	RXD	Receive Data (RS-232C)
4	TXD	Transmit Data (RS-232C)
5	5V	Request to send
6	0V	Clear to Send

T1K-DEVNETS

Communications Specification	
Communication Form	DeviceNet Communication Protocol (Slave) Predefined Master/Slave Group 2 Server only
Network Node Address	0 to 63 (Rotary switch setting)
Data Packet	0 to 8 Bytes (Data beyond eight bytes are divided.)
Communication Rate (Maximum cable length)	125000 Baud (1640ft / 500m) 250000 Baud (820ft / 250m) 500000 Baud (328ft / 100m)
Communication Status Indicators	MS: Module Status LED Green: normal device operation Red: unrecoverable controller fault NS: Network Status LED Green: communication link on-line and connected Green flashing: on-line, but not connected Red: critical link or controller failure Red flashing: connection time-out
DeviceNet Power Consumption	45mA @ 11 to 25VDC
Base Power Consumption	190mA @ 5VDC

DeviceNet Specifications			
Device Type	Generic	Configuration Consistency	No
Explicit Peer to Peer Message	No	Fault Node Recovery	No
I/O Peer to Peer Message	No	Master Scanner	No
Communication Baud Rate 125K, 250K, 500K	Yes	I/O Slave Message Bit Strobe Polling Cyclic Change of State	No Yes No No

General Specifications	
Installation Requirements	Must mount to the right of the first power supply in a slave system.
Operating Temperature	32°F to 131°F (0°C to 55°C)
Storage Temperature	-4°F to 158°F (-20°C to 70°C)
Ambient Humidity	5% to 95% relative humidity (Non-condensing)
Voltage Withstand	1500VAC, 1 minute (DeviceNet connector internal)
Insulation Resistance	500VDC, 10MΩ (DeviceNet connector internal)
Vibration Resistance	MIL STD 810C. Method 514.2
Shock	MIL STD 810C. Method 514.2
Noise Immunity	NEMA (ICSS-304) Impulse Noise 1μs, 1000V FCC class A RFI (145MHz, 435MHz 10W, 10cm)
Atmosphere	No corrosive gases Environmental Pollution Level 2
Weight	6.0 oz (170g)

Dimensions

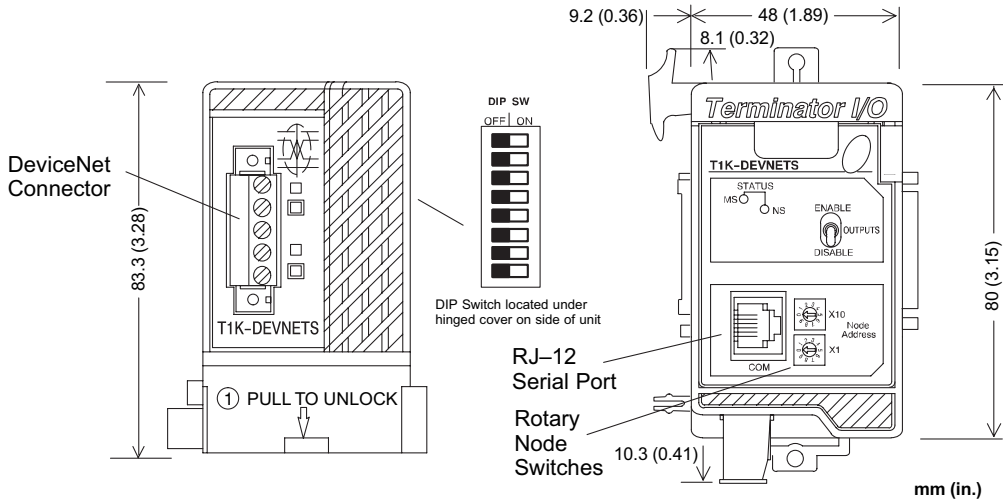

T1K-DEVNETS Serial Port Pin-out

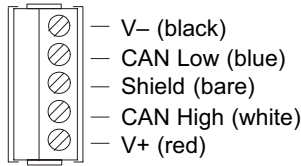

Use Belden Cable 3084A, or equivalent.

T1K-DEVNETS DIP Switch Settings

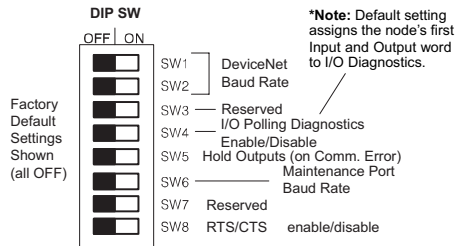

Serial Port

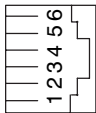

RJ-12

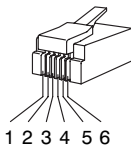

Serial Port Pin Descriptions		
Pin	Signal	Definition
1	0V	Power (-) connection (GND)
2	5V	Power (+) connection
3	RXD	Receive Data (RS-232C)
4	TXD	Transmit Data (RS-232C)
5	RTS	Request to send
6	CTS	Clear to Send

SW 1-2 DeviceNet Baud Rate		
Baud Rate	SW1	SW2
125 kbps	OFF	OFF
250 kbps	ON	OFF
500 kbps	OFF	ON
Reserved	ON	ON

SW 5 Hold Outputs	
Outputs	SW5
Turn Off	OFF
Hold	ON

SW 4 Disable I/O Polling Diagnostics	
I/O Diagnostics	SW4
Enable	OFF
Disable	ON

SW 6 Maintenance Port Baud Rate	
Baud Rate	SW6
9600bps	OFF
19200bps	ON

SW 8 RTS / CTS Enable / Disable	
RTS/CTS	SW8
Disable	OFF
Enable	ON

*See Dip SW 4 Note above.

T1K-MODBUS Base Controller

Specifications	
Communication Protocol	MODBUS RTU (Slave)
MODBUS Connector	15-pin female D-shell
MODBUS Port Type	RS-232C, RS-422 / 485
Station Address	1 to F7h (247), Rotary switch setting
Number of I/O Points	Discrete: Inputs: 1024, Outputs: 1024 Analog: Inputs: 64 Channels, Outputs: 64 Channels
Communication Baud Rate	(300, 600, 1200, 4800, 9600, 19200, 38400) Baud Dip Switch 1-3 Set
Communication Data	8-bit (fixed), 1 Start bit, 1 Or 2 Stop bit Parity: None / Odd / Even; configure using Setup Tool Defaults: 8 (fixed), 1, 1, Odd
Communication Time out	500ms, 1s, 2.5 s, 5s, 10s, 25s, 60s Default: 1s; configure using Setup Tool
RTS On / Off Delay Time	(0, 2, 5, 10, 50, 100, 500) ms Default: 0ms; configure using Setup Tool
Status Indicators	RWR (green): ON when power good RX (green): ON when data is being received TX (green): ON when data is being transmitted RUN (green): ON when communicating with Master ERR (red): Communication error DIAG (red): I/O system error
Output Enable Switch	Enable: outputs are enabled Disable: outputs are disabled
Installation Requirement	Must mount to the right of the first power supply in a slave system.
Base Power Requirements	250mA @ 5VDC
Communication Port (RJ-12 Serial Port)	RJ-12, RS-232C Use to configure MODBUS port using MODBUS Setup Tool Utility or use to upgrade firmware Baud rate: 9600, 19,200 Baud (set with Dip Switch 6) Fixed settings: 8 data bits, 1 start bit, parity Odd

General Specifications	
Installation Requirements	Must mount to the right of the first power supply in a slave system.
Operating Temperature	32°F to 131°F (0°C to 55°C)
Storage Temperature	-4°F to 158°F (-20°C to 70°C)
Ambient Humidity	30% to 95% relative humidity (Non-condensing)
Voltage Withstand	1500VAC, 1 minute (15-pin connector internal)
Insulation Resistance	500VDC, 10MΩ
Vibration Resistance	MIL STD 810C. Method 514.2
Shock	MIL STD 810C. Method 514.2
Noise Immunity	NEMA (ICS3-304) Impulse Noise 1μs, 1000V FCC class A RFII (145MHz, 435MHz)
Atmosphere	No corrosive gases Environmental Pollution Level 2
Weight	6.0 oz (170g)

Dimensions

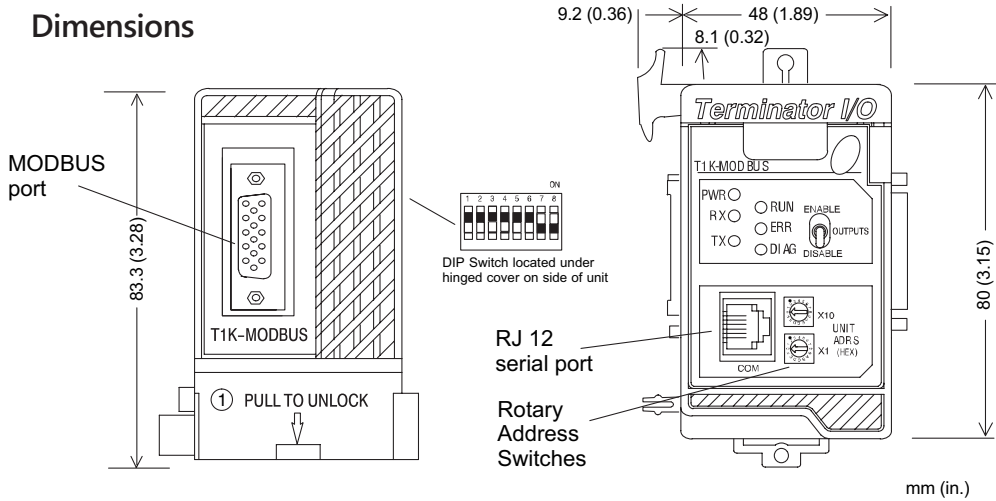

T1K-MODBUS DIP Switch Settings

MODBUS Port Pin-out		
Pin		Signal Definition
1	5V	5VDC
2	TXD	Transmit Data (RS-232C)
3	RXD	Receive Data (RS-232C)
4	RTS	Request to Send (RS-232C)
5	CTS	Clear to Send (RS-232C)
6	RXD-	Receive Data - (RS-422)
7	0V	Logic Ground
8	0V	Logic Ground
9	TXD+	Transmit Data + (RS-422)
10	TXD-	Transmit Data - (RS-422)
11	RTS+	Request to Send + (RS-422)
12	RTS-	Request to Send - (RS-422)
13	RXD+	Receive Data + (RS-422)
14	CTS+	Clear to Send + (RS-422)
15	CTS-	Clear to Send - (RS-422)

SW 1-3 MODBUS Port Baud Rates			
Baud Rate	SW 1	SW 2	SW 3
300	OFF	OFF	OFF
600	ON	OFF	OFF
1200	OFF	ON	OFF
2400	ON	ON	OFF
4800	OFF	OFF	ON
9600	ON	OFF	ON
19200	OFF	ON	ON
38400	ON	ON	ON

SW 6 Maintenance Port Baud Rate	
Baud Rate	SW6
9600	OFF
19200	ON

SW 7 MODBUS RTU Addressing Mode	
Mode	SW7
584/984	OFF
DirectLogic	ON

SW 4 Communication Setting Mode	
Default Mode	OFF
Option Mode (see T1K-MODBUS Manual)	ON

SW 8 RTS / CTS Enable / Disable	
RTS / CTS	SW8
Disable	OFF
Enable	ON

SW 5 Hold Output	
Outputs	SW5
Turn Off	OFF
Hold	ON

Serial Port Pin-out	
Pin	Signal
1	0V
2	+5V
3	RXD
4	TXD
5	RTS
6	CTS

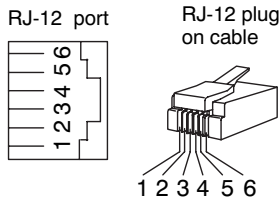

Default Mode	
Communication Data	8 Bit
Start Bit	1 Bit
Stop Bit	1 Bit
Parity Bit	Odd
Communication Time Out	1 sec.
RTS ON Delay Time	0 ms
RTS OFF Delay Time	0 ms

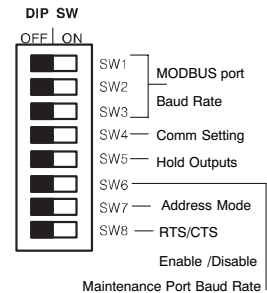

T1K-RSSS Remote I/O Base Controller (Retired)



* Note: T1K-RSSS was discontinued 05/2014; no replacement available.

Specification			
Module Type	Non-intelligent slave		
Protocol	SM-NET	RM-NET	
Station Address	1 to 31 set by rotary switches	1 to 7 set by rotary switches	
Number of Masters per PLC CPU	Check PLC CPU / remote Master module remote I/O specifications		
Max. Slave I/O Points per PLC CPU	Check PLC CPU / remote Master module remote I/O specifications		
Baud Rate / Communication Distance (set by DIP switches)	Baud Rate	Distance	Baud Rate Distance
	19200	1200m	19200 1.2km
	38400	1200m	38400 1.2km
	153600	600m	
	307200	300m	
614400	100m		
LED Indicators	RUN: On when communication is active. DIAG: On when a slave hardware failure error occurs. I/O Fast Blink: I/O error (250ms on / off time). Slow Blink: I/O configuration error while outputs are enabled (500ms on / off time). Continuous ON: I/O and configuration error. LINK: On when a communication error occurs.		
Output Enable Switch	Enable: outputs are enabled Disable: outputs are disabled		
Communication Port (active in SM-NET only)	RJ-12, RS-232C (K-Sequence) Dip switch selectable: Baud rate: 4800–38400 bps * select 9600 baud for operator interface (default) (other baud rates are for updating T1K-RSSS) Parity: odd (default), even Fixed settings: 8 data bits, 1 start bit, 1 stop bit		
Base Power Requirement	250mA @ 5VDC		
Communication Cabling	For remote I/O, RS-485 twisted pair Belden 9841 or equivalent.		

General Specifications	
Installation Requirements	Must mount to the right of the first power supply in a slave.
Operating Temperature	32°F to 131°F (0°C to 55°C)
Storage Temperature	-4°F to 158°F (-20°C to 70°C)
Relative Humidity	5% to 95% (Non-condensing)
Environmental Air	No corrosive gases. The level of environmental pollution = 2 (UL 840).
Vibration	MIL STD 810C. Method 514.2
Shock	MIL STD 810C. Method 514.2
Noise Immunity	NEMA ICS3-304 Impulse Noise 1µs, 1000V FCC class A RFI (144MHz, 430MHz 10W, 10cm)

Dimensions

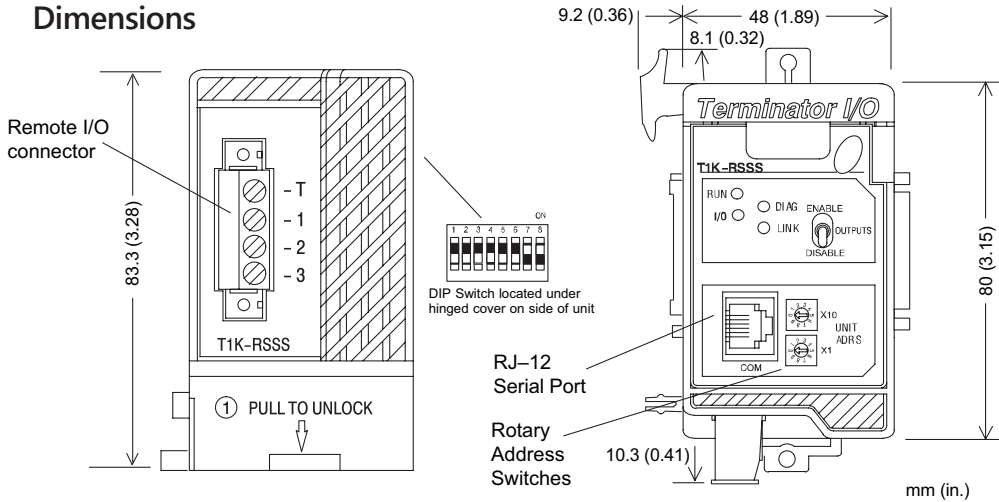

T1K-RSSS DIP Switch Settings

SW 1 Mode	
OFF	SM-NET
ON	RM-NET

Baud Rate	SW 2, 3, 4 Baud Rates		
	SW 1	SW 2	SW 3
19200	OFF	OFF	OFF
38400	ON	OFF	OFF
153600	OFF	ON	OFF
307200	ON	ON	OFF
614400	OFF	OFF	ON

Baud rates above 38.4 kbps are for SM-NET only.

SW 5 Output Default	
Outputs	SW5
Clear	OFF
Hold	ON

SW 6 Serial Port Parity	
Odd	OFF
None	ON
SM-NET only	

SW 7-8 Serial Port Baud Rate		
Baud Rate	SW7	SW8
4800	ON	OFF
9600	OFF	OFF
19200	OFF	ON
38400	ON	ON

Port Active in SM-NET only
Use 9600, odd parity for Operator Interface

T1K-RSSS Serial Port Pin-out

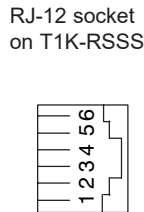
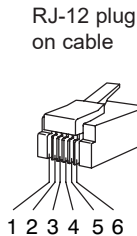

Serial Port Pin Descriptions		
Pin	Signal	Definition
1	0V	Power (-) connection (GND)
2	5V	Power (+) connection
3	RXD	Receive Data (RS-232C)
4	TXD	Transmit Data (RS-232C)
5	5V	Request to send
6	0V	Clear to Send

T1H-PBC PROFIBUS Base Controller (Retired)



** Note: T1H-PBC was discontinued 08/2020; no replacement available.*

Specifications	
Module Type	PROFIBUS Network Interface Module
Maximum Expansion	32 stations per segment, repeaters max./segment, 126 stations maximum
Communications	RS-485
Auto-configuring	GSD file in Master
PROFIBUS Profile	DP (Decentralized Periphery)
PROFIBUS Port	9-pin D-shell
Node Address	1 to 126 (decimal) set by rotary switches or software (0 used by Master)
Segment Distance	100 meters (328 feet) to 1200 meters (3270 feet)
Baud Rate	Selectable from 9.6 kbps to 12 Mbps
LED Indicators	STATUS (Module): ON = module power-up check passed ACTIVE (Link): ON = Network is active OFF = Network is not active TOKEN (Holding): ON = OFF = Incorrect I/O configuration ERROR: ON = watchdog timer timeout represents hardware, communications or network fault; power-on reset or reset within master device software
Communications Port	RJ-12, RS-232C K-Sequence protocol, ASCII (not functional when used with H2-ERM).
Base Power Requirements	350mA @ 5VDC (EBC); Serial port supports up to 500mA @ 5VDC (add for power budget consumption).

General Specifications	
Installation Requirements	Must mount to the right of the first power supply.
Operating Temperature	32°F to 131°F (0°C to 55°C)
Storage Temperature	-4°F to 158°F (-20°C to 70°C)
Relative Humidity	5% to 95% (Non-condensing)
Environmental Air	No corrosive gases. The level of environmental pollution = 2 (UL 840).
Vibration	MIL STD 810C. Method 514.2
Shock	MIL STD 810C. Method 514.2
Noise Immunity	NEMA (ICS3-304) Impulse Noise 1 μ s, 1000V FCC class A RFI (144MHz, 430MHz 10W, 10cm)
Manufacturer	Host Automation Products

Dimensions

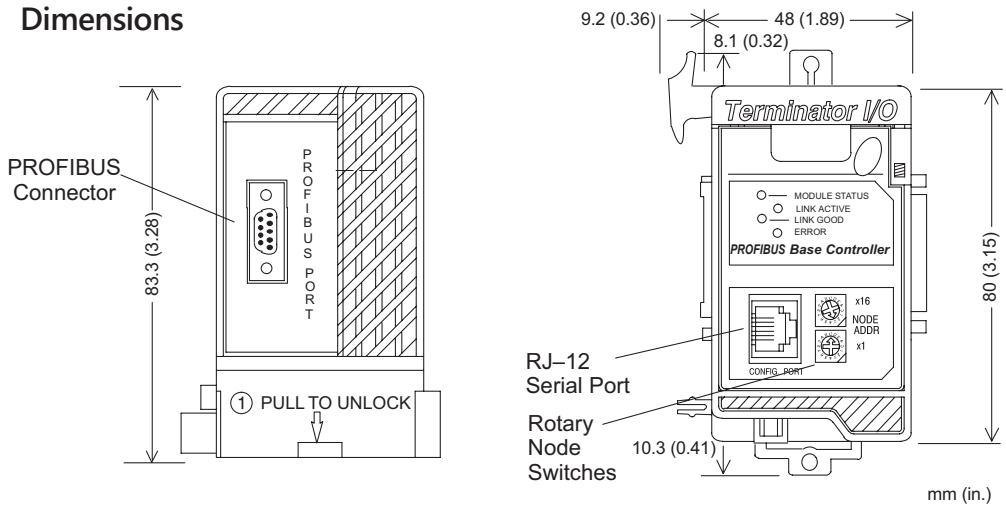

* Note: T1H-PBC was discontinued 08/2020; no replacement available.

T1H-PBC Port Pin-out

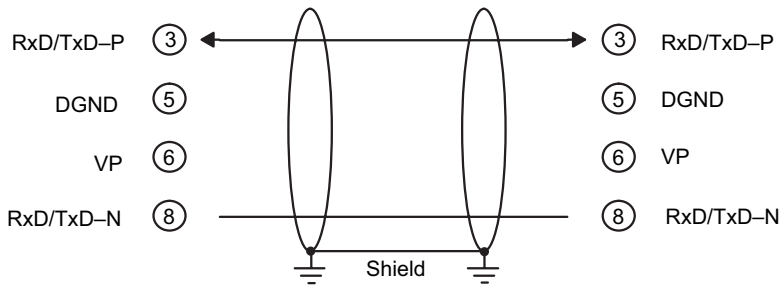

Use Belden PROFIBUS 3079A Cable or Siemens 6XV1 830 0AH10

Serial (Config) Port

(Use for firmware upgrades only)

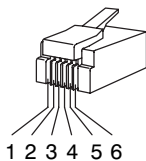

RJ-12 plug
on cable

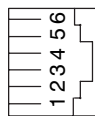

Serial Port Pin Descriptions

Pin	Signal	Definition
1	0 V	Power (-) connection (GND)
2	5 V	Power (+) connection
3	RXD	Receive Data (RS-232C)
4	TXD	Transmit Data (RS-232C)
5	RTS	Request to send
6	CTS	Clear to Send

T1K-08ND3 DC Input

Specifications	
Inputs Per Module	8 (sink / source)
Commons Per Module	Ext. power: 2, isolated (4 pts. / com.) Int. power: 2, all 8 pts. internally connected
Operating Voltage	12-24 VDC
Input Voltage Range	10.8-26.4 VDC min. / max.
Peak Voltage	30VDC
Input Current (Typical)	4mA @ 12VDC, 8.5mA @ 24VDC
Input Impedance	2.8 K Ω
ON Voltage Level	> 10.0 VDC
OFF Voltage Level	< 2.0 VDC
Min. ON Current	4mA
Max. OFF Current	0.5 mA
OFF to ON Response	2-8 m., Typical: 4ms
ON to OFF Response	2-8 ms, Typical: 4ms
Base Power Requirements	35mA @ 5VDC
Status Indicators	Logic Side
Weight	70g

Environmental Specifications	
Ambient Operating Temperature	32°F to 131°F (0°C to 55°C)
Storage Temperature	-4°F to 158°F (-20°C to 70°C)
Ambient Humidity	5% to 95% (Non-condensing)
Atmosphere	No corrosive gases. The level of environmental pollution = 2 (UL 840).
Vibration Resistance	MIL STD 810C. Method 514.2
Shock Resistance	MIL STD 810C. Method 514.2
Voltage Withstand	1500VAC, 1 minute
Insulation Resistance	500VDC, 10M Ω
Noise Immunity	NEMA ICS3-304 Impulse Noise 1 μ s, 1000V FCC class A RFI (144MHz, 430MHz 10W, 10cm)
Agency Approvals	UL, CE, FCC class A

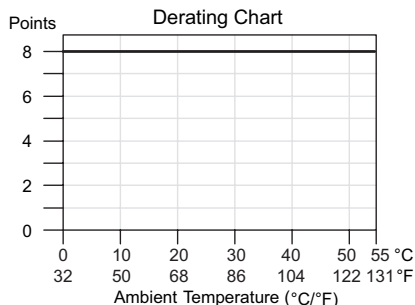

Wiring & Dimensions

Note:
External Power,
Sink Module
Configuration
Shown

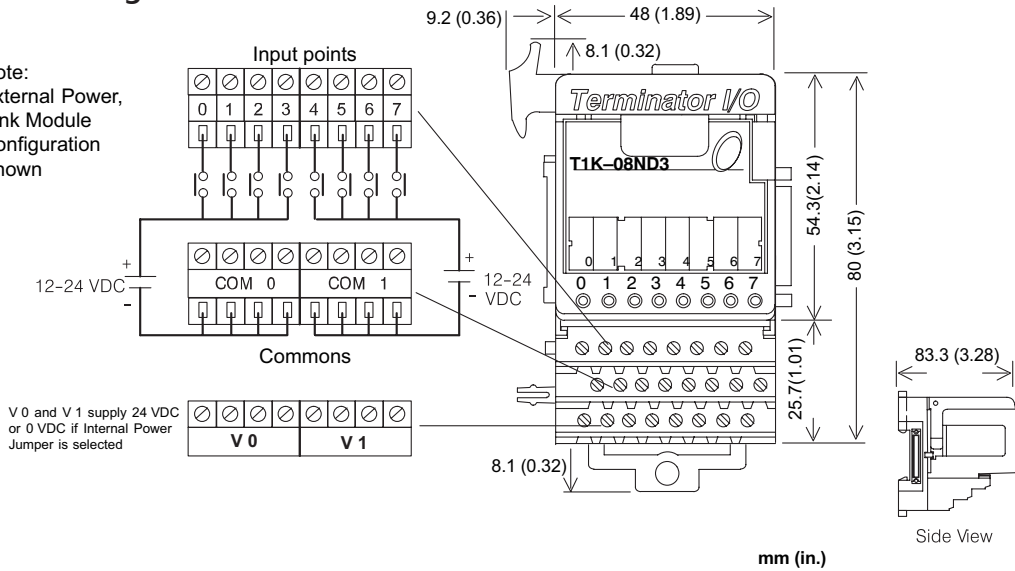

Jumper Selection

External Power

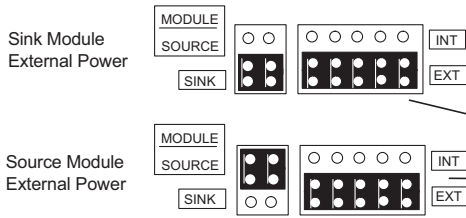

Equivalent Input Circuit

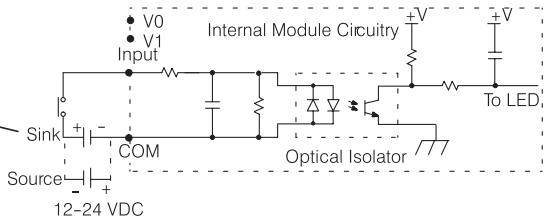

Internal Power

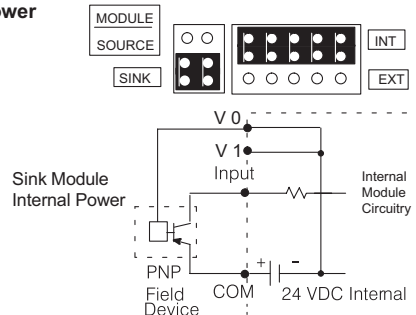
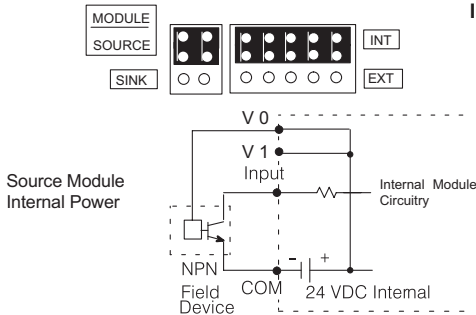

T1K-16ND3 DC Input

Specifications	
Inputs Per Module	16 (sink / source)
Commons Per Module	Ext. power: 4, isolated (4 pts. / com.) Int. power: 4, all 16 pts. internally connected
Operating Voltage	12-24 VDC
Input Voltage Range	10.8-26.4 VDC min. / max.
Peak Voltage	30VDC
Input Current (Typical)	4mA @ 12VDC, 8.5 mA @ 24VDC
Input Impedance	2.8 kΩ
ON Voltage Level	> 10.0 VDC
OFF Voltage Level	< 2.0 VDC
Min. ON Current	4mA
Max. OFF Current	0.5 mA
OFF to ON Response	2-8 ms, Typical: 4ms
ON to OFF Response	2-8 ms, Typical: 4ms
Base Power Requirements	70mA @ 5VDC
Status Indicators	Logic Side
Weight	160g

Environmental Specifications	
Ambient Operating Temperature	32°F to 131°F (0°C to 55°C)
Storage Temperature	-4°F to 158°F (-20°C to 70°C)
Ambient Humidity	5% to 95% (Non-condensing)
Atmosphere	No corrosive gases. The level of environmental pollution = 2 (UL 840).
Vibration Resistance	MIL STD 810C. Method 514.2
Shock Resistance	MIL STD 810C. Method 514.2
Voltage Withstand	1500VAC, 1 minute
Insulation Resistance	500VDC, 10MΩ
Noise Immunity	NEMA ICS3-304 Impulse Noise 1μs, 1000V FCC class A RFI (144MHz, 430MHz 10W, 10cm)
Agency Approvals	UL, CE, FCC class A

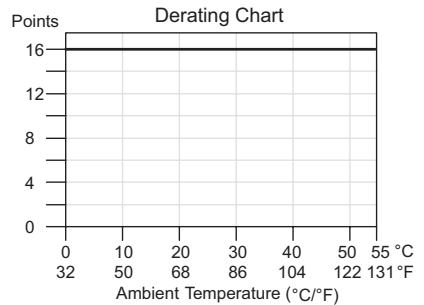

Wiring & Dimensions

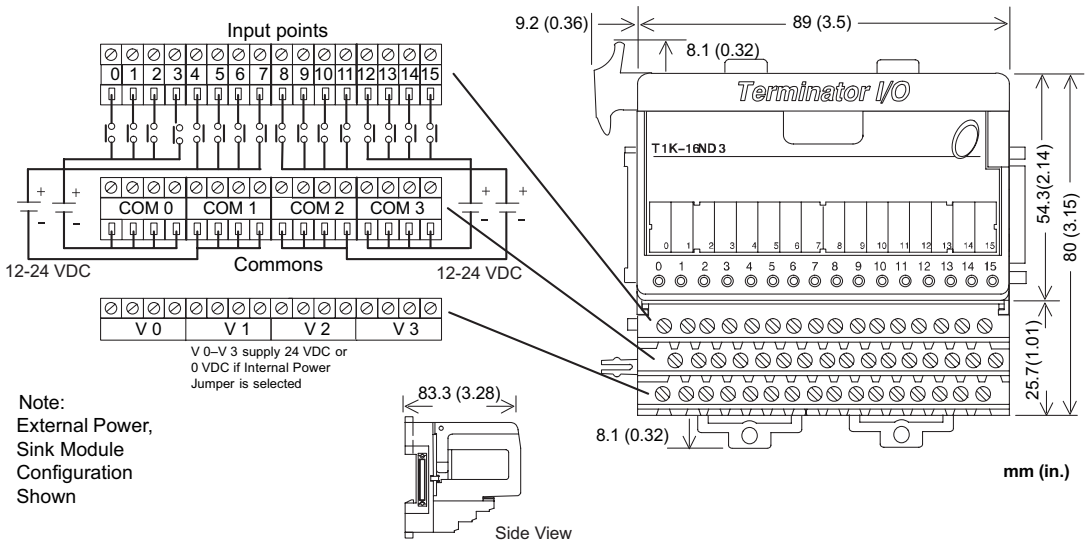

NOTE: When using external power, the module can be wired to either sink current or source current regardless of the module sink/source jumper position. When using internal power, the sink/source jumpers determine the module configuration.

Jumper Selection

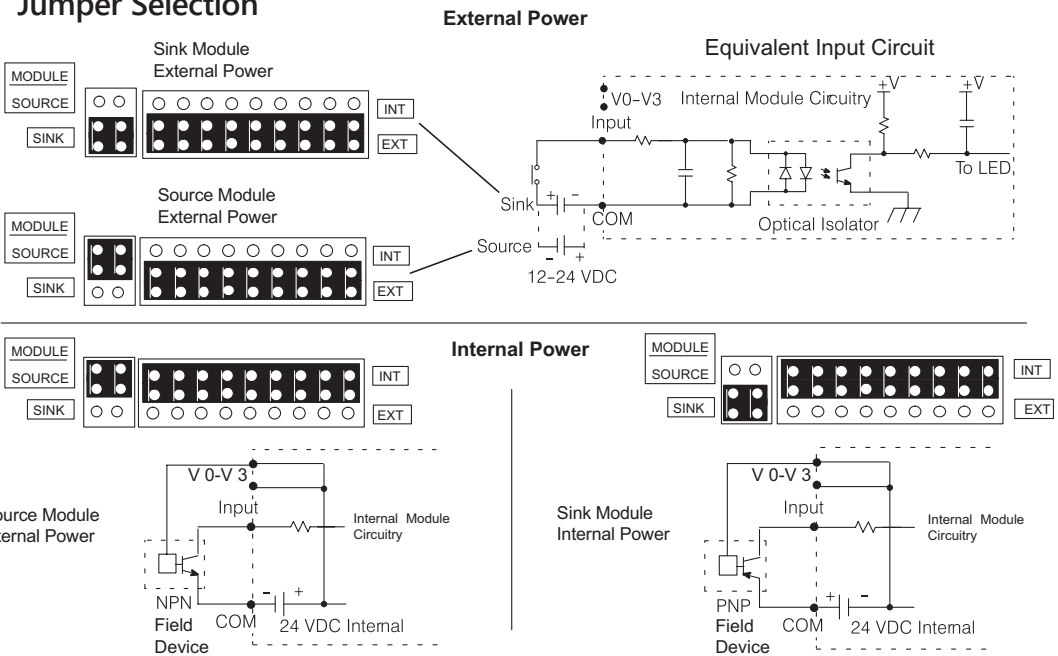

T1K-08NA-1 AC Input

Specifications	
Inputs Per Module	8
Commons Per Module	2, 4 pts. / com (isolated)
Operating Voltage	90-120 VAC, 47-63 Hz
Input Voltage Range	80-132 VAC, 47-63 Hz min. / max.
Input Current	8mA @ 100VAC (50Hz) 10mA @ 100VAC (60Hz) 12mA @ 132VAC (50Hz) 15mA @ 132VAC (60Hz)
Input Impedance	14k Ω @ 50Hz, 12k Ω @ 60Hz
ON Current / Voltage	> 6mA @ 75VAC
OFF Current / Voltage	< 2.0 mA @ 20VAC
OFF to ON Response	< 40ms
ON to OFF Response	< 40ms
Base Power Requirements	35mA @ 5VDC
Status Indicators	Logic Side
Weight	70g

Environmental Specifications	
Ambient Operating Temperature	32°F to 131°F (0°C to 55°C)
Storage Temperature	-4°F to 158°F (-20°C to 70°C)
Ambient Humidity	5% to 95% (Non-condensing)
Atmosphere	No corrosive gases. The level of environmental pollution = 2 (UL 840).
Vibration Resistance	MIL STD 810C. Method 514.2
Shock Resistance	MIL STD 810C. Method 514.2
Voltage Withstand	1500VAC, 1 minute
Insulation Resistance	500VDC, 10M Ω
Noise Immunity	NEMA ICS3-304 Impulse Noise 1 μ s, 1000V FCC class A RFI (144MHz, 430MHz 10W, 10cm)
Agency Approvals	UL, CE, FCC class A

Wiring & Dimensions

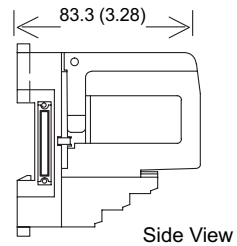
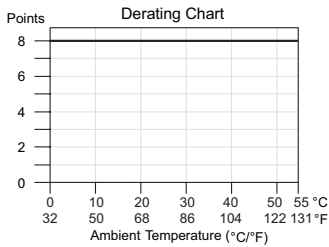
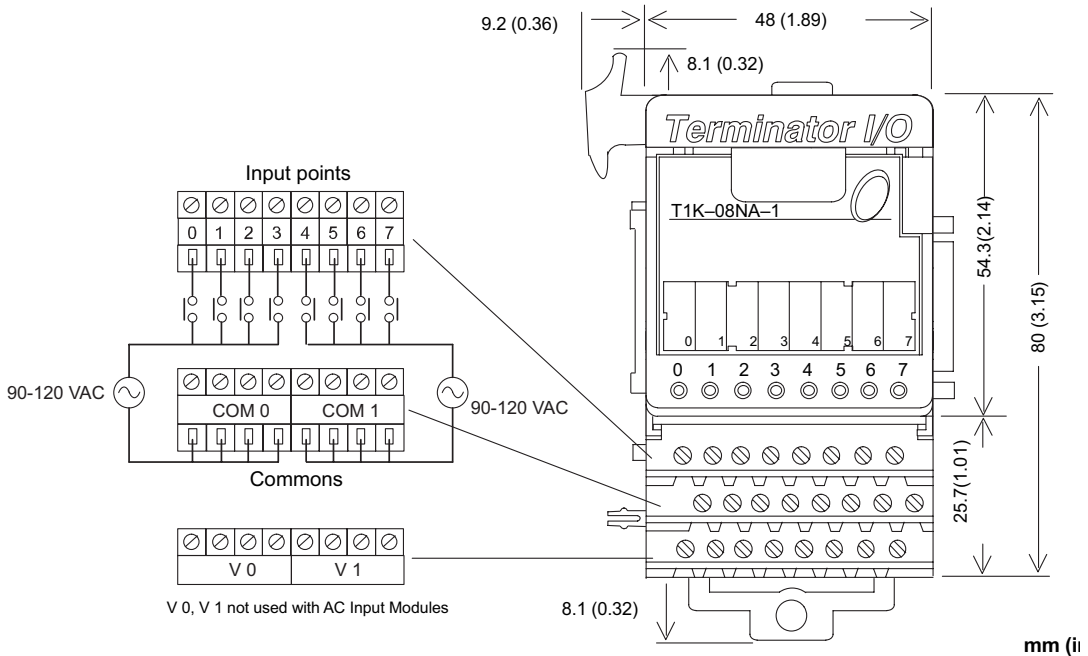

Equivalent Input Circuit

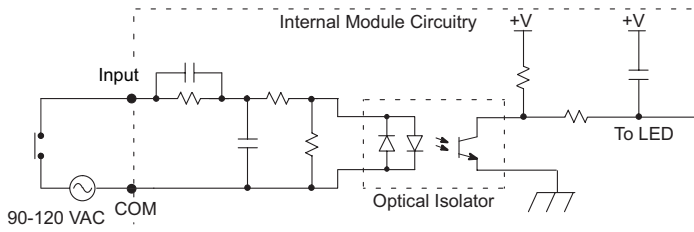

T1K-16NA-1 AC Input

Specifications	
Inputs Per Module	16
Commons Per Module	4, 4 pts. / com (isolated)
Operating Voltage	90-120 VAC, 47-63 Hz
Input Voltage Range	80-132 VAC, 47-63 Hz min. / max.
Input Current	8mA @ 100VAC (50Hz) 10mA @ 100VAC (60Hz) 12mA @ 132VAC (50Hz) 15mA @ 132VAC (60Hz)
Input Impedance	14k Ω @ 50Hz, 12k Ω @ 60Hz
ON Current / Voltage	> 6mA @ 75VAC
OFF Current / Voltage	< 2.0 mA @ 20VAC
OFF to ON Response	< 40ms
ON to OFF Response	< 40ms
Base Power Requirements	70mA @ 5VDC
Status Indicators	Logic Side
Weight	120g

Environmental Specifications	
Ambient Operating Temperature	32°F to 131°F (0°C to 55°C)
Storage Temperature	-4°F to 158°F (-20°C to 70°C)
Ambient Humidity	5% to 95% (Non-condensing)
Atmosphere	No corrosive gases. The level of environmental pollution = 2 (UL 840).
Vibration Resistance	MIL STD 810C. Method 514.2
Shock Resistance	MIL STD 810C. Method 514.2
Voltage Withstand	1500VAC, 1 minute
Insulation Resistance	500VDC, 10M Ω
Noise Immunity	NEMA ICS3-304 Impulse Noise 1 μ s, 1000V FCC class A RFI (144MHz, 430MHz 10W, 10cm)
Agency Approvals	UL, CE, FCC class A

Wiring & Dimensions

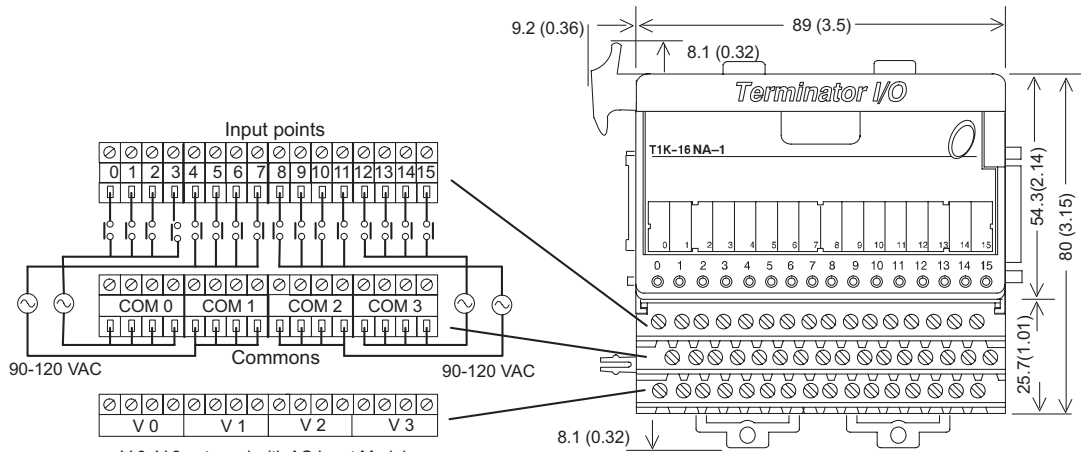

mm (in.)

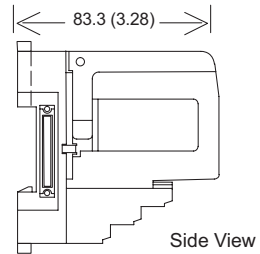
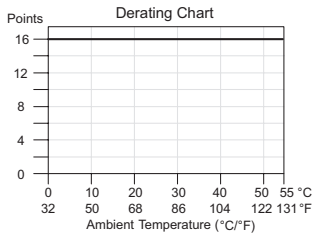

Equivalent Input Circuit

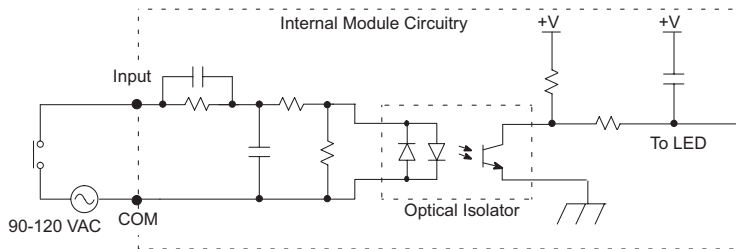

T1K-08TD1 DC Output

Specifications	
Outputs Per Module	8 (sink)
Commons Per Module	2 internally connected
Operating Voltage Range	6–27 VDC
Output Voltage Range	5–30 VDC min. / max.
Peak Voltage	50VDC
Max. Load Current	1A / pt., 4A / common
Max. Leakage Current	15 μ A @ 30VDC
ON Voltage Drop	0.3 VDC @ 1.0 A
Max. Inrush Current	2A for 100ms
OFF to ON Response	< 10 μ s
ON to OFF Response	< 60 μ s
Base Power Requirements	100mA @ 5VDC
External Power Required	200mA max. @ 20–28 VDC
Status Indicators	Logic Side
Error Status Indicators (LEDS)	24 V ON = low external power FU1 / FU2 ON = fuse 1 or fuse 2 blown
Fuses (User Replaceable)	2, (6.3 A, 250V / common), (4 pts. / fuse)
T1K-FUSE-1	NQ3 - 6.3 SOC corp.
Weight	85g

Environmental Specifications	
Ambient Operating Temperature	32°F to 131°F (0°C to 55°C)
Storage Temperature	-4°F to 158°F (-20°C to 70°C)
Ambient Humidity	5% to 95% (Non-condensing)
Atmosphere	No corrosive gases. The level of environmental pollution = 2 (UL 840).
Vibration Resistance	MIL STD 810C. Method 514.2
Shock Resistance	MIL STD 810C. Method 514.2
Voltage Withstand	1500VAC, 1 minute
Insulation Resistance	500VDC, 10M Ω
Noise Immunity	NEMA ICS3-304 Impulse Noise 1 μ s, 1000V FCC class A RFI (144MHz, 430MHz 10W, 10cm)
Agency Approvals	UL, CE, FCC class A

Wiring & Dimensions

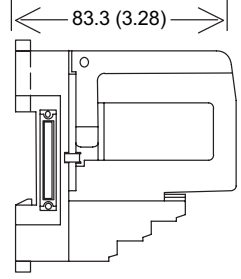
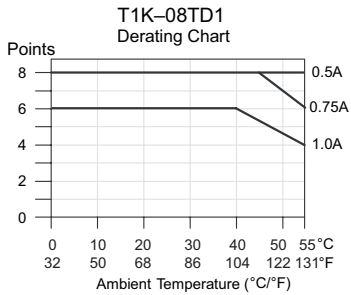
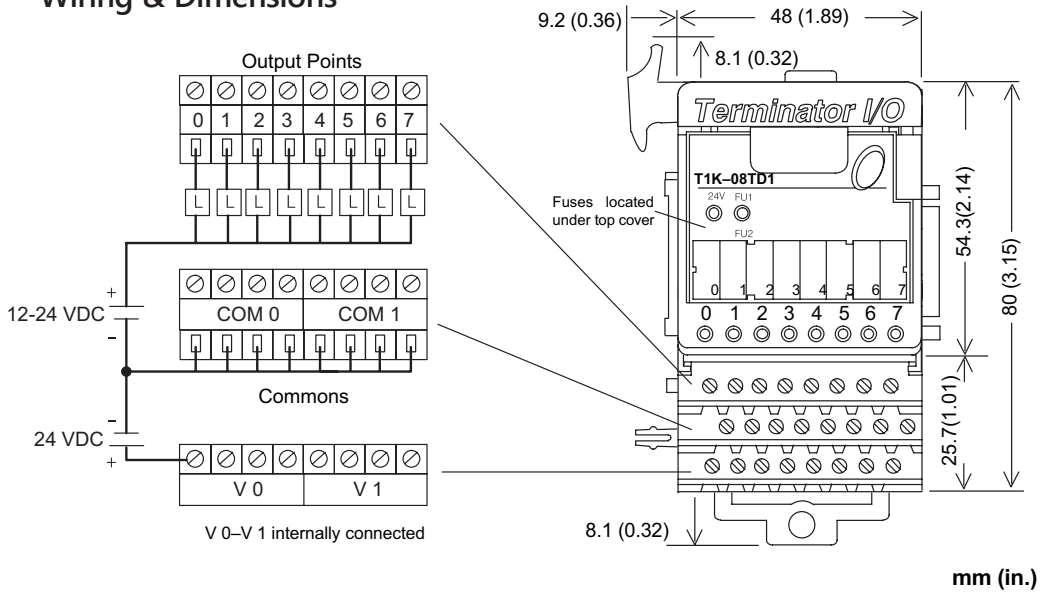

Side View

Equivalent Output Circuit

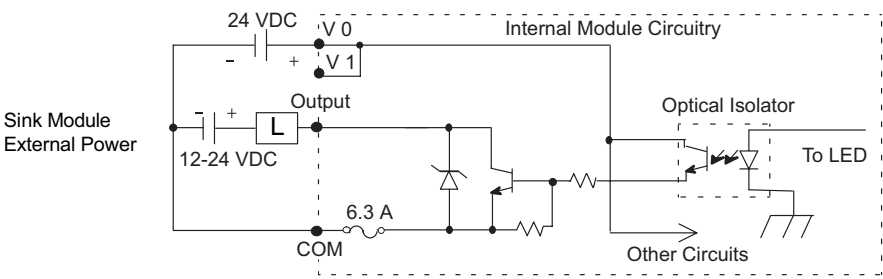

T1K-08TD2-1 DC Output

Specifications	
Outputs Per Module	8 (sourcing)
Commons Per Module	2 internally connected
Operating Voltage Range	12-24 VDC
Output Voltage Range	10.8-26.4 VDC min. / max.
Peak Voltage	50VDC
Max. Load Current	1A / pt., 4A / common
Max. Leakage Current	15 μ A @ 26.4 VDC
ON Voltage Drop	1.2 VDC @ 1.0 A
Max. Inrush Current	2A for 100ms
OFF to ON Response	< 10 μ s
ON to OFF Response	< 0.5 ms
Base Power Requirements	100mA @ 5VDC
Status Indicators	Logic Side
Error Status Indicators (LEDS)	FU1 / FU2 ON = fuse 1 or fuse 2 blown
Fuses (User Replaceable)	2, (6.3 A, 250V / common), (4 pts. / fuse)
T1K-FUSE-1	NQ3 - 6.3 SOC corp.
Weight	100g

Environmental Specifications	
Ambient Operating Temperature	32°F to 131°F (0°C to 55°C)
Storage Temperature	-4°F to 158°F (-20°C to 70°C)
Ambient Humidity	5% to 95% (Non-condensing)
Atmosphere	No corrosive gases. The level of environmental pollution = 2 (UL 840).
Vibration Resistance	MIL STD 810C. Method 514.2
Shock Resistance	MIL STD 810C. Method 514.2
Voltage Withstand	1500VAC, 1 minute
Insulation Resistance	500VDC, 10M Ω
Noise Immunity	NEMA ICS3-304 Impulse Noise 1 μ s, 1000V FCC class A RFI (144MHz, 430MHz 10W, 10cm)
Agency Approvals	UL, CE, FCC class A

Wiring & Dimensions

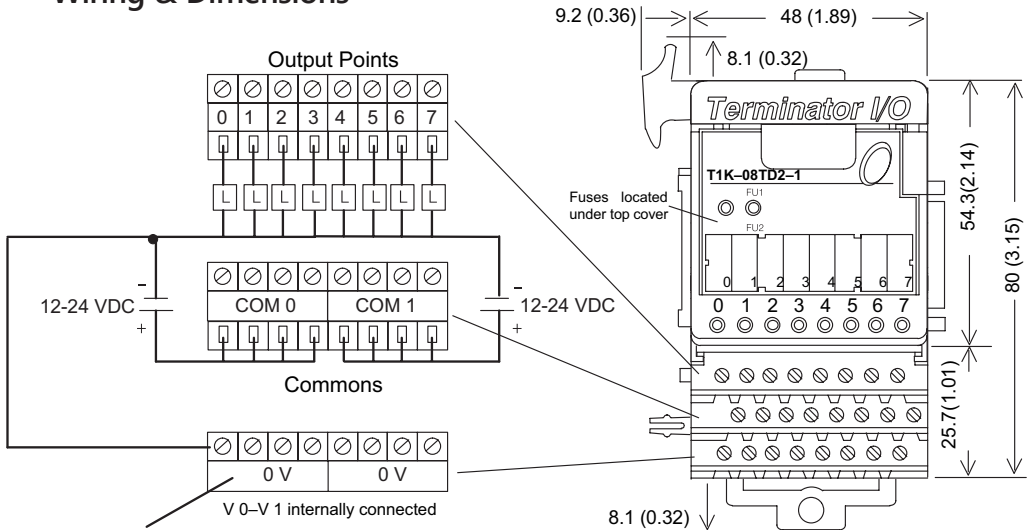

Note: Apply the 0 V label that comes with the I/O module to I/O base terminal points V 0-V 1 to properly identify the 0 VDC terminal points.

mm (in.)

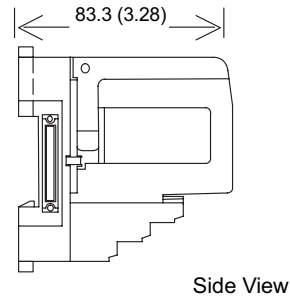
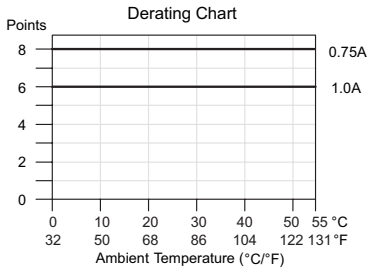

Side View

Equivalent Output Circuit

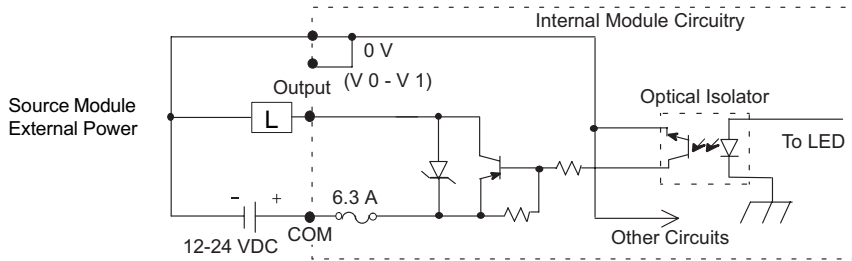

T1H-08TDS Isolated DC Output

Specifications	
Outputs Per Module	8 (isolated, sink / sourcing)
Commons Per Module	8 (isolated)
Operating Voltage Range	5-36 VDC
Max. Voltage	36VDC
Output Clamp Voltage	40VDC
Max. Load Current	2A / pt., 16A / module, 32°F to 140°F (0°C to 60°C)
Electronic Over Current Protection	Output trips at 6A min., 12A max.
Max. Load Voltage	36VDC
Max. Leakage Current	75µA
Max. ON State Voltage Drop	0.3 VDC @ 2.0 A, 0.15 V @ 1A
Inrush Current	5A for 20ms
OFF to ON Response	< 3µs
ON to OFF Response	< 100µs
Base Power Requirements	200mA max.
Thermal Shutdown	Between Tjunction = 302°F to 374°F (150°C to 190°C)
Over Temperature Reset	Thermal shutdown temp. minus 5°F (15°C)
Status Indicators	Logic Side
Weight	93.6 g

Environmental Specifications	
Ambient Operating Temperature	32°F to 140°F (0°C to 60°C)
Storage Temperature	-4°F to 158°F (-20°C to 70°C)
Ambient Humidity	5% to 95% (Non-condensing)
Atmosphere	No corrosive gases. The level of environmental pollution = 2 (UL 840).
Vibration Resistance	MIL STD 810C. Method 514.2
Shock Resistance	MIL STD 810C. Method 514.2
Voltage Withstand	1500VAC, 1 minute
Insulation Resistance	500VDC, 10MΩ
Noise Immunity	NEMA ICS3-304 Impulse Noise 1µs, 1000V FCC class A RFI (144MHz, 430MHz 10W, 10cm)
Agency Approvals	UL, CE, FCC class A

Wiring & Dimensions

Note: Apply the labels that come with the I/O module to the I/O base to properly identify the terminal points.

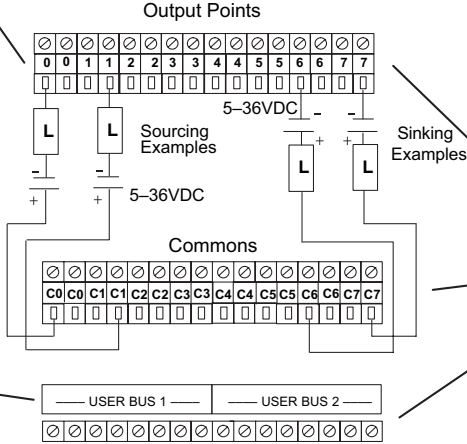

No connection: The 8 User Bus 1 terminals are bussed together. The 8 User Bus 2 terminals are also bussed together.

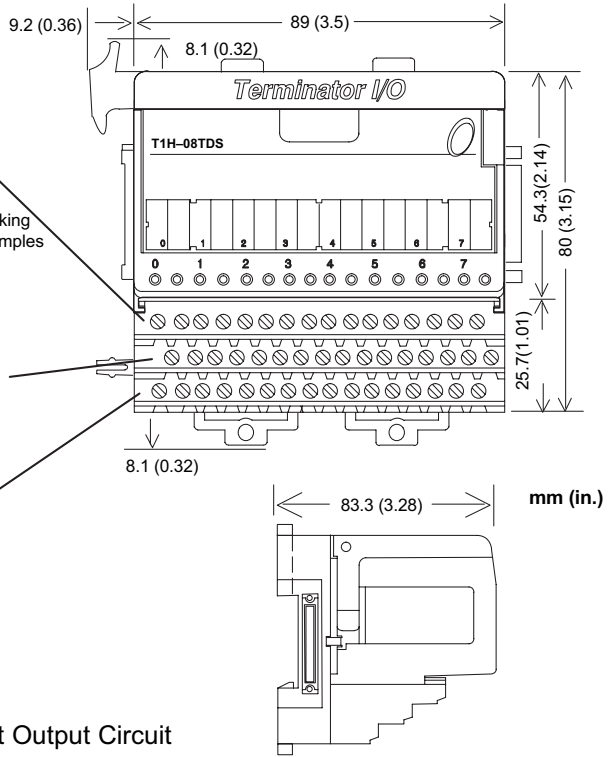

Equivalent Output Circuit

Sourcing (High Side Switching)

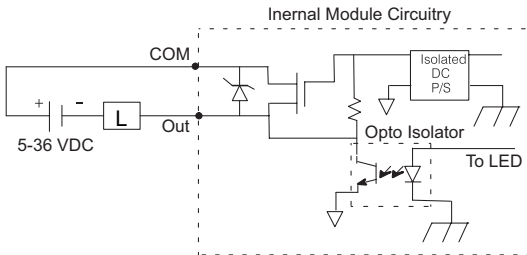

Sinking (Low Side Switching)

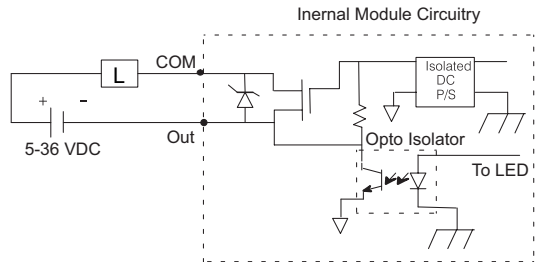

Side View

T1K-16TD1 DC Output

Specifications	
Outputs Per Module	16 (sink)
Commons Per Module	4 internally connected
Operating Voltage Range	6-27 VDC
Output Voltage Range	5-30 VDC min. / max.
Peak Voltage	50VDC
Max. Load Current	1A / pt., 4A / common
Max. Leakage Current	15 μ A @ 30VDC
ON Voltage Drop	0.3 VDC @ 1.0 A
Max. Inrush Current	2A for 100ms
OFF to ON Response	< 10 μ s
ON to OFF Response	< 60 μ s
Base Power Requirements	200mA @ 5VDC
External Power Required	400mA max. @ 20-28VDC
Status Indicators	Logic Side
Error Status Indicators (LEDS)	24V ON = low external power FU1 / FU2 ON = fuse 1 or 2 blown FU3 / FU4 ON = fuse 3 or 4 blown
Fuses (User Replaceable) T1K-FUSE-1	4, (6.3 A, 250V / common), (4 pts. / fuse) NQ3 - 6.3 SOC corp.
Weight	140g

Environmental Specifications	
Ambient Operating Temperature	32°F to 140°F (0°C to 60°C)
Storage Temperature	-4°F to 158°F (-20°C to 70°C)
Ambient Humidity	5% to 95% (Non-condensing)
Atmosphere	No corrosive gases. The level of environmental pollution = 2 (UL 840).
Vibration Resistance	MIL STD 810C. Method 514.2
Shock Resistance	MIL STD 810C. Method 514.2
Voltage Withstand	1500VAC, 1 minute
Insulation Resistance	500VDC, 10M Ω
Noise Immunity	NEMA ICS3-304 Impulse Noise 1 μ s, 1000V FCC class A RFI (144MHz, 430MHz 10W, 10cm)
Agency Approvals	UL, CE, FCC class A

Wiring & Dimensions

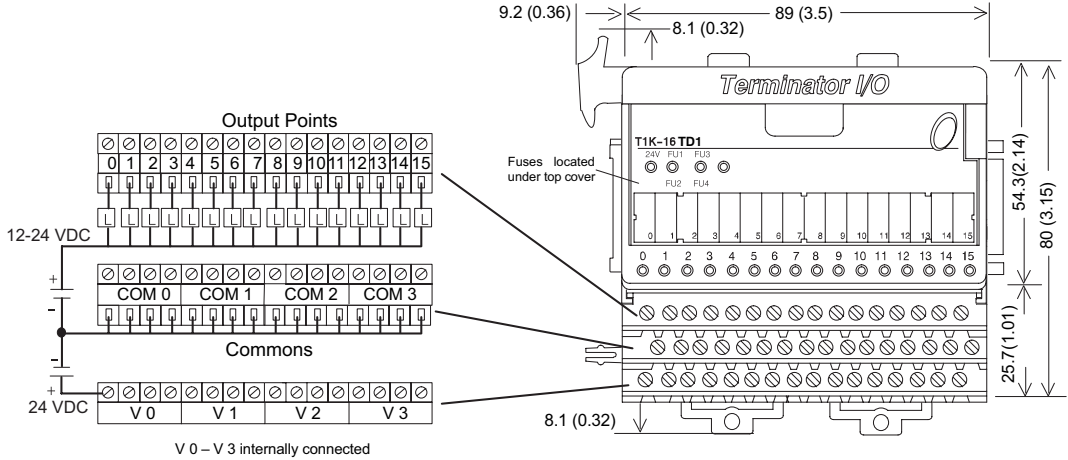

mm (in.)

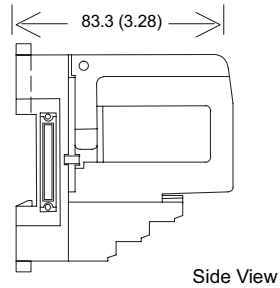
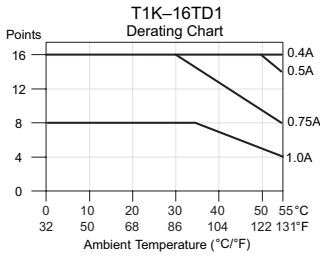

Equivalent Output Circuit

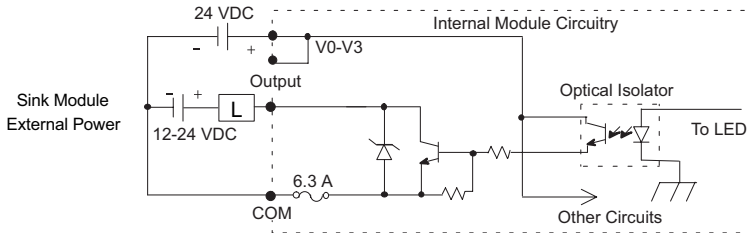

T1K-16TD2-1 DC Output

Specifications	
Outputs Per Module	16 (source)
Commons Per Module	4 internally connected
Operating Voltage Range	12–24 VDC
Output Voltage Range	10.8–26.4 VDC min. / max.
Peak Voltage	50VDC
Max. Load Current	1A / pt., 4A / common (subject to derating)
Max. Leakage Current	15 μ A @ 26.4VDC
ON Voltage Drop	1.2VDC @ 1.0 A
Max. Inrush Current	2A for 100ms
OFF to ON Response	< 10 μ s
ON to OFF Response	< 0.5 ms
Base Power Requirements	200mA @ 5VDC
Status Indicators	Logic Side
Error Status Indicators (LEDS)	FU1 / FU2 ON = fuse 1 or 2 blown FU3 / FU4 ON = fuse 3 or 4 blown
Fuses (User Replaceable) T1K-FUSE-1	4, (6.3 A, 250V / common), (4pts. / fuse) NQ3 - 6.3 SOC corp.
Weight	140g

Environmental Specifications	
Ambient Operating Temperature	32°F to 140°F (0°C to 60°C)
Storage Temperature	-4°F to 158°F (-20°C to 70°C)
Ambient Humidity	5% to 95% (Non-condensing)
Atmosphere	No corrosive gases. The level of environmental pollution = 2 (UL 840).
Vibration Resistance	MIL STD 810C. Method 514.2
Shock Resistance	MIL STD 810C. Method 514.2
Voltage Withstand	1500VAC, 1 minute
Insulation Resistance	500VDC, 10M Ω
Noise Immunity	NEMA ICS3-304 Impulse Noise 1 μ s, 1000V FCC class A RFI (144MHz, 430MHz 10W, 10cm)
Agency Approvals	UL, CE, FCC class A

Wiring & Dimensions

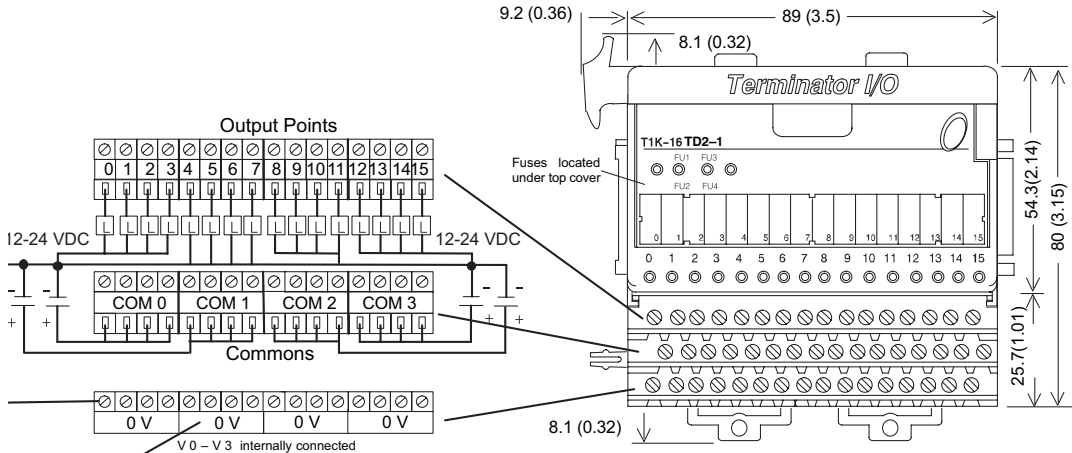

mm (in.)

Note: Apply the 0 V label that comes with the I/O module to I/O base terminal points V 0–V 3 to properly identify the 0 VDC terminal points.

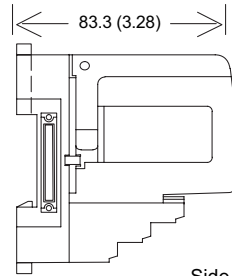
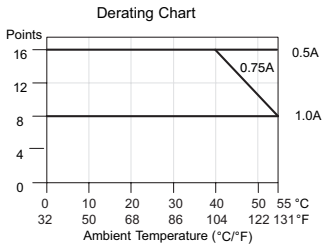

Side View

Equivalent Output Circuit

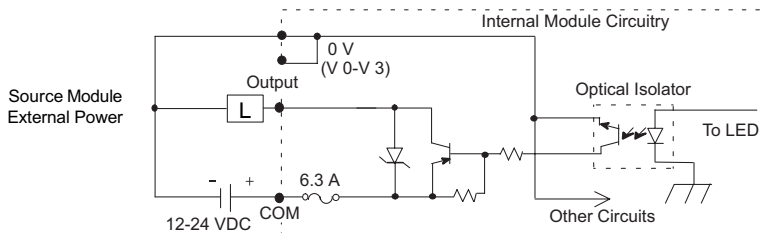

T1K-08TA AC Output

Specifications	
Outputs Per Module	8
Commons Per Module	2, 4 pts. / common (isolated)
Operating Voltage Range	17–240 VAC (47–63 Hz)
Output Voltage Range	15–264 VAC (47–63 Hz) min. / max.
Max. Load Current	1A / pt., 4A / common (subject to derating)
ON Voltage Drop	1.5 VAC @ > 50mA, 4.0 VAC @ < 50mA
Max. Leakage Current	4mA @ 264VAC
Max. Inrush Current	10A for 10ms
Min. Load	10mA
OFF to ON Response	< 1ms
ON to OFF Response	< 1ms + 1/2 cycle
Base Power Requirements	250mA @ 5VDC
Status Indicators	Logic Side
Error Status Indicators (LEDS)	FU1 ON = fuse 1 blown FU2 ON = fuse 2 blown
Fuses (User Replaceable) T1K-FUSE-2	2, (10A, 250V / common), (4 pts. / fuse) 5 x 20mm type
Weight	140g

Environmental Specifications	
Ambient Operating Temperature	32°F to 140°F (0°C to 60°C)
Storage Temperature	-4°F to 158°F (-20°C to 70°C)
Ambient Humidity	5% to 95% (Non-condensing)
Atmosphere	No corrosive gases. The level of environmental pollution = 2 (UL 840).
Vibration Resistance	MIL STD 810C. Method 514.2
Shock Resistance	MIL STD 810C. Method 514.2
Voltage Withstand	1500VAC, 1 minute
Insulation Resistance	500VDC, 10MΩ
Noise Immunity	NEMA ICS3-304 Impulse Noise 1μs, 1000V FCC class A RFI (144MHz, 430MHz 10W, 10cm)
Agency Approvals	UL, CE, FCC class A

Wiring & Dimensions

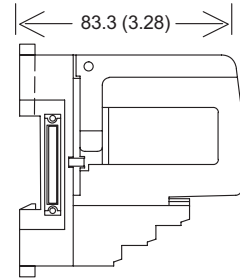
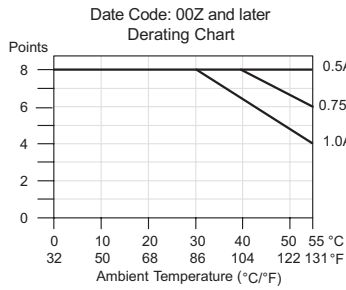
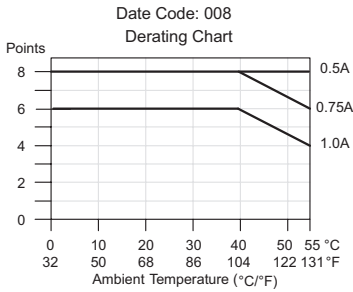
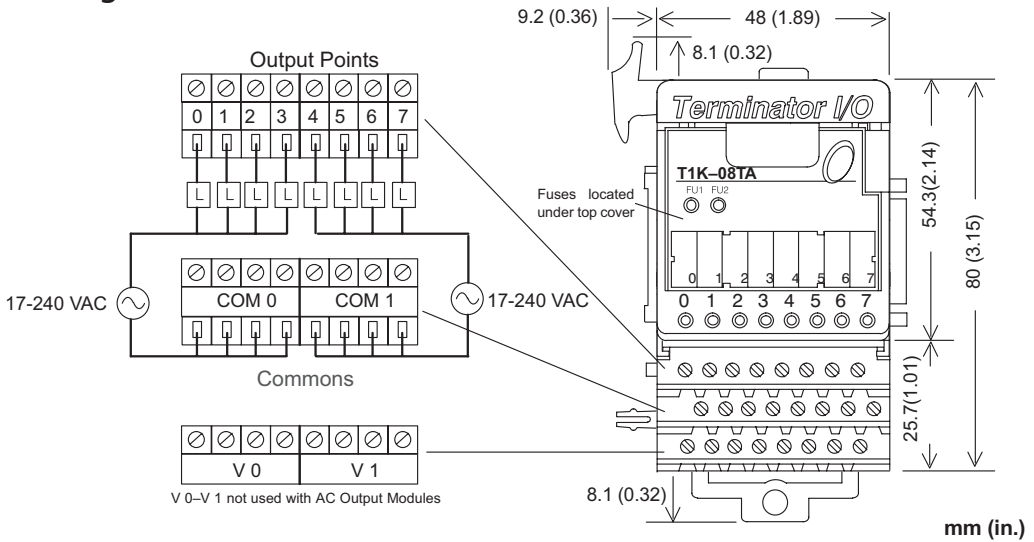

Side View

Equivalent Output Circuit

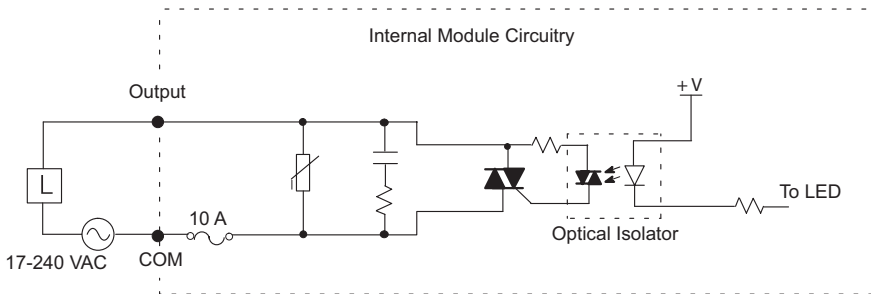

T1K-16TA AC Output

Specifications	
Outputs Per Module	16
Commons Per Module	4, 4 pts. / common (isolated)
Operating Voltage Range	17–240 VAC (47–63 Hz)
Output Voltage Range	15–264 VAC (47–63 Hz) min. / max.
Max. Load Current	1A / pt., 4A / common (subject to derating)
ON Voltage Drop	1.5 VAC @ > 50mA, 4.0 VAC @ < 50mA
Max. Leakage Current	4mA @ 264VAC
Max. Inrush Current	10A for 10ms
Min. Load	10mA
OFF to ON Response	< 1ms
ON to OFF Response	< 1ms + 1/2 cycle
Base Power Requirements	450mA @ 5VDC
Status Indicators	Logic Side
Error Status Indicators (LEDS)	FU1 / FU2 ON = fuse 1 or 2 blown FU3 / FU4 ON = fuse 3 or 4 blown
Fuses (User Replaceable)	4, (10A, 250V / common), (4pts. / fuse)
T1K-FUSE-2	5 x 20mm type
Weight	190g

Environmental Specifications	
Ambient Operating Temperature	32°F to 140°F (0°C to 60°C)
Storage Temperature	-4°F to 158°F (-20°C to 70°C)
Ambient Humidity	5% to 95% (Non-condensing)
Atmosphere	No corrosive gases. The level of environmental pollution = 2 (UL 840).
Vibration Resistance	MIL STD 810C. Method 514.2
Shock Resistance	MIL STD 810C. Method 514.2
Voltage Withstand	1500VAC, 1 minute
Insulation Resistance	500VDC, 10MΩ
Noise Immunity	NEMA ICS3-304 Impulse Noise 1μs, 1000V FCC class A RFI (144MHz, 430MHz 10W, 10cm)
Agency Approvals	UL, CE, FCC class A

Wiring & Dimensions

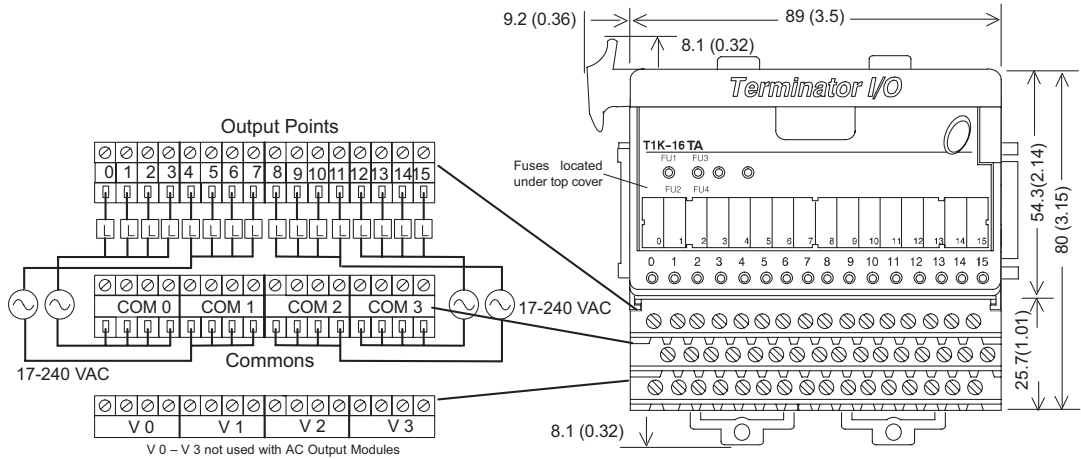

mm (in.)

Date Code: 012 and Later
Derating Chart

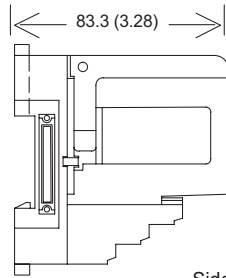
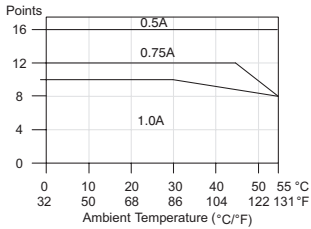

Side View

Equivalent Output Circuit

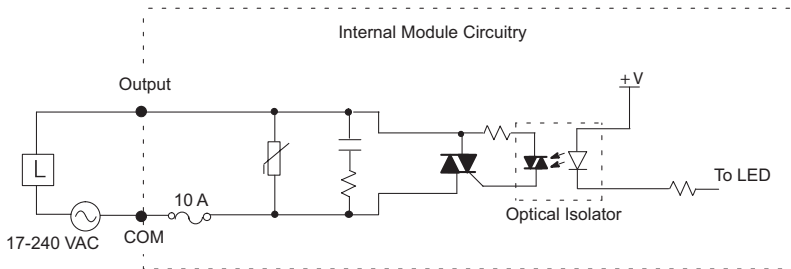

T1K-08TAS AC Output

Specifications	
Outputs Per Module	8
Commons Per Module	8, 1pt. / common (isolated)
Operating Voltage Range	17–40 VAC (47–63 Hz)
Output Voltage Range	15–264 VAC (47–63 Hz) min. / max.
Max. Load Current	2A / pt. common (subject to derating)
ON Voltage Drop	1.5 VAC @ > 50mA, 4.0 VAC @ < 50mA
Max. Leakage Current	4mA @ 264VAC
Max. Inrush Current	10A for 10ms
Min. Load	10mA
OFF to ON Response	<1ms
ON to OFF Response	<1ms + 1/2 cycle
Base Power Requirements	300mA @ 5VDC
Status Indicators	Logic Side
Error Status Indicators (LEDS)	FU1 / FU2 ON = fuse 1 or 2 blown FU3 / FU4 ON = fuse 3 or 4 blown FU5 / FU6 ON = fuse 5 or 6 blown FU7 / FU8 ON = fuse 7 or 8 blown
Fuses (User Replaceable) T1K-FUSE-3	8 (10A, 250V / common), (1pt. / fuse) NQ3-10 SOC Corp.
Weight	190g

Environmental Specifications	
Ambient Operating Temperature	32°F to 140°F (0°C to 60°C)
Storage Temperature	-4°F to 158°F (-20°C to 70°C)
Ambient Humidity	5% to 95% (Non-condensing)
Atmosphere	No corrosive gases. The level of environmental pollution = 2 (UL 840).
Vibration Resistance	MIL STD 810C. Method 514.2
Shock Resistance	MIL STD 810C. Method 514.2
Voltage Withstand	1500VAC, 1 minute
Insulation Resistance	500VDC, 10MΩ
Noise Immunity	NEMA ICS3-304 Impulse Noise 1μs, 1000V FCC class A RFI (144MHz, 430MHz 10W, 10cm)
Agency Approvals	UL, CE, FCC class A

Wiring & Dimensions

Note: Apply the labels that come with the I/O module to the I/O base to properly identify the terminal points.

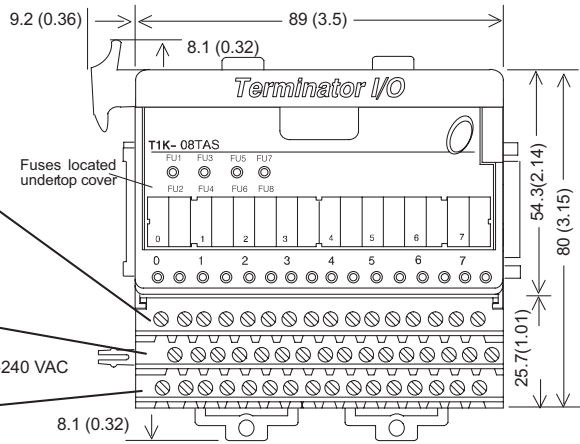
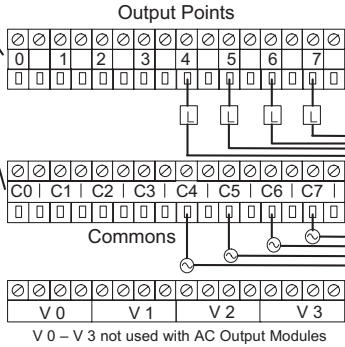

Date Code: 008
Derating Chart

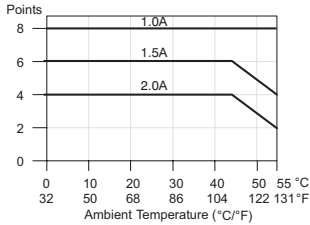

Date Code: 012 and later
Derating Chart

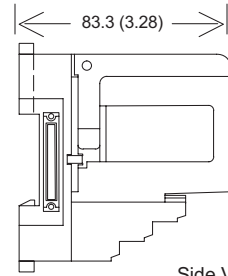
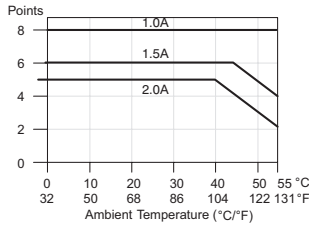

mm (in.)

Equivalent Output Circuit

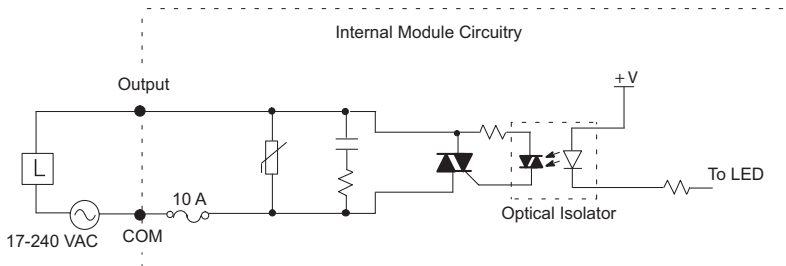

T1K-08TR Relay Output

Specifications	
Outputs Per Module	8
Output Type	Relay Form A (SPST) normally open
Commons Per Module	2, 4pts. / common (isolated)
Operating Voltage Range	6-240 VAC (47-63 Hz), 6-27 VDC
Output Voltage Range	5-264 VAC (47 - 63 Hz) min. / max. 5-30 VDC min / max
Max. Load Current	2A / pt., 8A / common
Max. Leakage Current	0.1mA @ 264VAC
Max. Inrush Current	6A for 10ms. / pt.; 20A for 10ms / common
Min. Load	5mA @ 5VDC
OFF to ON Response	< 15ms
ON to OFF Response	< 10ms
Base Power Requirements	350mA @ 5VDC
Status Indicators	Logic Side
Error Status Indicators (LEDS)	FU1 ON = fuse 1 blown FU2 ON = fuse 2 blown
Fuses (User Replaceable) T1K-FUSE-2	2 (10A, 250V / common), (4pts. / fuse) 5 x 20 mm type
Weight	110g

Environmental Specifications	
Ambient Operating Temperature	32°F to 140°F (0°C to 60°C)
Storage Temperature	-4°F to 158°F (-20°C to 70°C)
Ambient Humidity	5% to 95% (Non-condensing)
Atmosphere	No corrosive gases. The level of environmental pollution = 2 (UL 840).
Vibration Resistance	MIL STD 810C. Method 514.2
Shock Resistance	MIL STD 810C. Method 514.2
Voltage Withstand	1500VAC, 1 minute
Insulation Resistance	500VDC, 10MΩ
Noise Immunity	NEMA ICS3-304 Impulse Noise 1μs, 1000V FCC class A RFI (144MHz, 430MHz 10W, 10cm)
Agency Approvals	UL, CE, FCC class A

Wiring & Dimensions

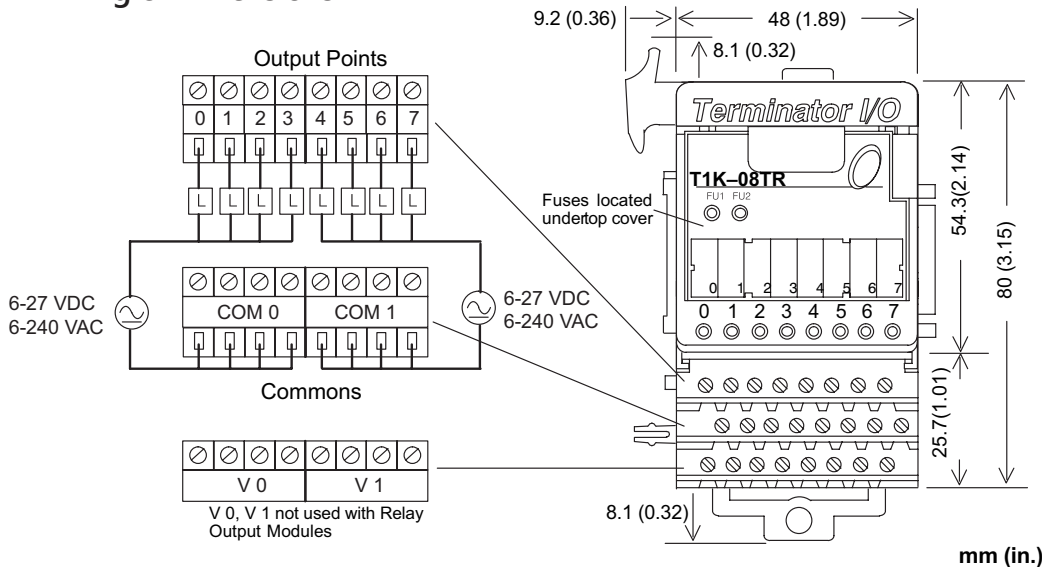

Equivalent Output Circuit

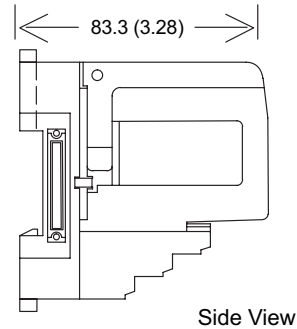
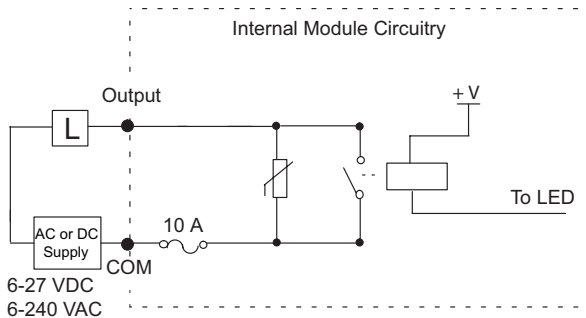

Typical Relay Life (Operations) at Room Temperature		
Voltage & Type of Load	Load Current	
	1 A	2 A
24VDC Resistive	500 K	250 K
24VDC Solenoid	100 K	50 K
110VAC Resistive	500 K	250 K
110VAC Resistive	200 K	100 K
220VAC Resistive	350 K	200 K
220VAC Resistive	100 K	50 K

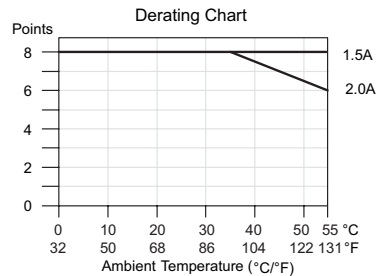

T1K-16TR Relay Output

Specifications	
Outputs Per Module	16
Output Type	Relay Form A (SPST) normally open
Commons Per Module	4, 4pts. / common (isolated)
Operating Voltage Range	6–240 VAC (47–63 Hz), 6–27 VDC
Output Voltage Range	5–264 VAC (47–63 Hz) min. / max. 5–30 VDC min / max
Max. Load Current	2A / pt., 6A / common
Max. Leakage Current	0.1 mA @ 264VAC
Max. Inrush Current	6A for 10ms / pt.; 20A for 10ms / common
Min. Load	5mA @ 5VDC
OFF to ON Response	< 15ms
ON to OFF Response	< 10ms
Base Power Requirements	700mA @ 5VDC
Status Indicators	Logic Side
Error Status Indicators (LEDS)	FU1 / FU2 ON = fuse 1 or fuse 2 blown FU3 / FU4 ON = fuse 3 or fuse 4 blown
Fuses (User Replaceable) T1K-FUSE-2	4 (10A, 250V / common), (4pts. / fuse) 5 x 20mm type
Weight	200g

Environmental Specifications	
Ambient Operating Temperature	32°F to 140°F (0°C to 60°C)
Storage Temperature	-4°F to 158°F (-20°C to 70°C)
Ambient Humidity	5% to 95% (Non-condensing)
Atmosphere	No corrosive gases. The level of environmental pollution = 2 (UL 840).
Vibration Resistance	MIL STD 810C. Method 514.2
Shock Resistance	MIL STD 810C. Method 514.2
Voltage Withstand	1500VAC, 1 minute
Insulation Resistance	500VDC, 10M Ω
Noise Immunity	NEMA ICS3-304 Impulse Noise 1 μ s, 1000V FCC class A RFI (144MHz, 430MHz 10W, 10cm)
Agency Approvals	UL, CE, FCC class A

Wiring & Dimensions

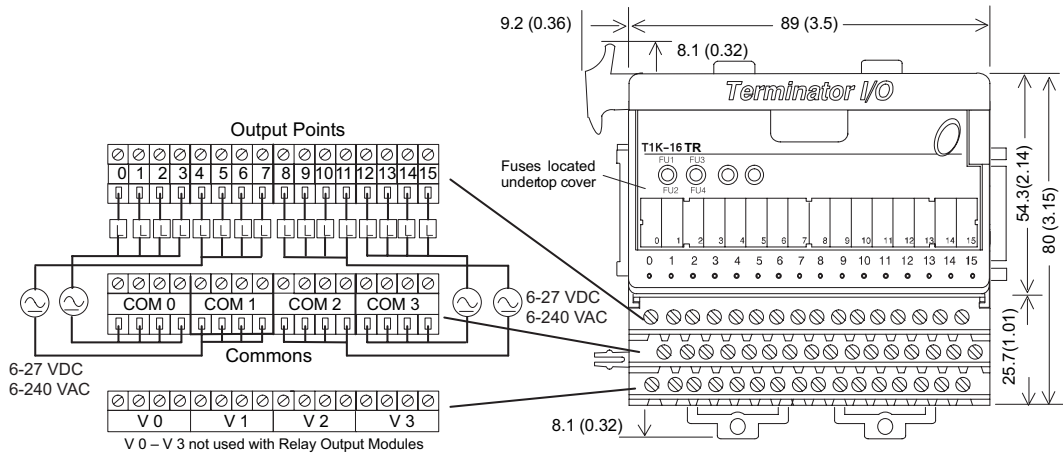

mm (in.)

Equivalent Output Circuit

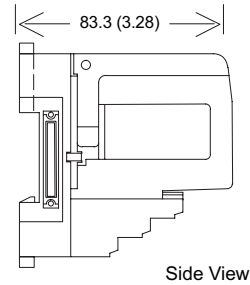
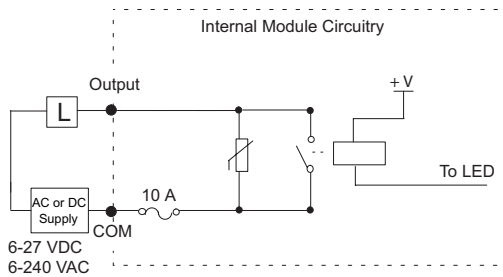

Typical Relay Life (Operations) at Room Temperature		
Voltage & Type of Load	Load Current	
	1 A	2 A
24VDC Resistive	500 K	250 K
24VDC Solenoid	100 K	50 K
110VAC Resistive	500 K	250 K
110VAC Resistive	200 K	100 K
220VAC Resistive	350 K	200 K
220VAC Resistive	100 K	50 K

Date Code: 012* and later
Derating Chart

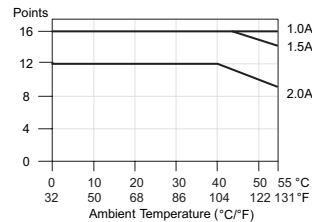

T1K-08TRS Relay Output

Specifications	
Outputs Per Module	8
Output Type	Relay Form A (SPST) normally open
Commons Per Module	8, 1pt. / common (isolated)
Operating Voltage Range	6-240 VAC (47-63 Hz), 6-27 VDC
Output Voltage Range	5-264 VAC (47-63 Hz) min. / max. 5-30 VDC min. / max.
Max. Load Current	7A / pt. common (subject to derating)
Max. Leakage Current	0.1 mA @ 264VAC
Max. Inrush Current	8A for 10ms
Min. Load	5mA @ 5VDC
OFF to ON Response	< 15ms
ON to OFF Response	< 10ms
Base Power Requirements	400mA @ 5VDC
Status Indicators	Logic Side
Error Status Indicators (LEDS)	FU1 / FU2 ON = fuse 1 or 2 blown FU3 / FU4 ON = fuse 3 or 4 blown FU5 / FU6 ON = fuse 5 or 6 blown FU7 / FU8 ON = fuse 7 or 8 blown
Fuses (User Replaceable) T1K-FUSE-3	8 (10A, 250V / common), (1pt. / fuse) NQ3-10 SOC Corp.
Weight	185g

Environmental Specifications	
Ambient Operating Temperature	32°F to 140°F (0°C to 60°C)
Storage Temperature	-4°F to 158°F (-20°C to 70°C)
Ambient Humidity	5% to 95% (Non-condensing)
Atmosphere	No corrosive gases. The level of environmental pollution = 2 (UL 840).
Vibration Resistance	MIL STD 810C. Method 514.2
Shock Resistance	MIL STD 810C. Method 514.2
Voltage Withstand	1500VAC, 1 minute
Insulation Resistance	500VDC, 10MΩ
Noise Immunity	NEMA ICS3-304 Impulse Noise 1μs, 1000V FCC class A RFI (144MHz, 430MHz 10W, 10cm)
Agency Approvals	UL, CE, FCC class A

Wiring & Dimensions

Note: Apply the labels that come with the I/O module to the I/O base to properly identify the terminal points.

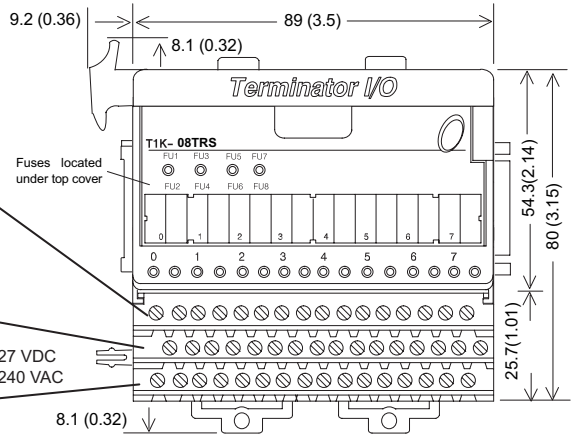
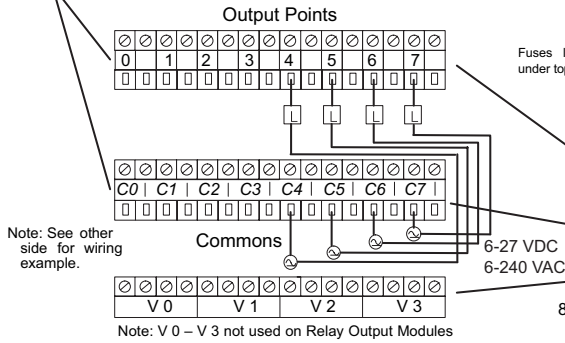

mm (in.)

Equivalent Output Circuit

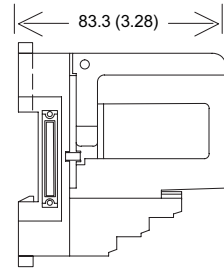
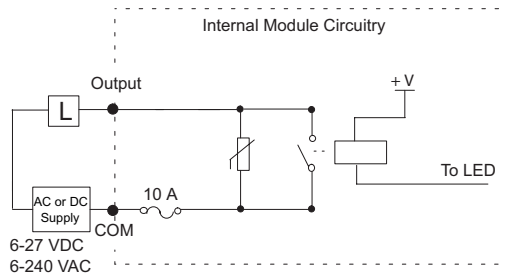

Side View

Typical Relay Life (Operations) at Room Temperature

Voltage & Type of Load	Load Current			
	1 A	2 A	5 A	7 A
24VDC Resistive	1000 K	500 K	200 K	100 K
24VDC Solenoid	300 K	100 K	**	**
110VAC Resistive	1000 K	500 K	200 K	100 K
110VAC Resistive	300 K	100 K	**	**
220VAC Resistive	500 K	250 K	125 K	60 K
220VAC Resistive	300 K	100 K	**	**

**Solenoid (inductive) loads > 2A cannot be used.

Derating Chart

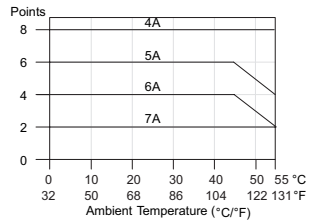

T1F-08AD-1 8-Channel Current Analog Input

Specifications	
Number of Channels	8, single ended (1 common)
Input Ranges	0–20 mA, 4–20mA, - 20 to 20mA
Resolution	14 bit (13 bit plus sign bit)
Frequency Response	- 3db @ 500 Hz, - 20db / decade
Input Resistance	250Ω
Absolute Maximum Ratings	8V max. Input
Conversion Time (Default: Normal Mode)	Normal Mode: 5ms per channel Fast Mode: 0.5 ms per channel (Fast Mode supported in module hardware version B or later, and only when using this analog module with the T1H-EBC(100) or T1H-PBC control module)
Linearity Error	±2 count max.
Input Stability	±1 count
Full Scale Error (Offset Error not included)	16 counts max.
Offset Error	2 counts max.
Max. Full Scale Inaccuracy (% of full scale); all errors included	0.18% @ 25°C 0.36% @ 60°C
Master Update Rate	8 channels per scan max.
Input Points Required	256 discrete pts. or 8 dwords (d (double) word = 32 bit word) Network Interface dependent
Base Power Required	75mA @ 5VDC
External Module Power Supply Req.	18–30VDC, 50mA, class 2
Recommended Fuse	0.032 A @ 5VDC, Series 217 Fast Acting
Operating Temperature	0°to 60°C (32°to 140°F)
Storage Temperature	- 20°to 70°C (- 4°to 158°F)
Accuracy vs. Temperature	±50ppm / °C max. full scale
Relative Humidity	5 to 95% (non-condensing)
Environmental Air	No corrosive gases permitted
Vibration	MIL STD 810C 514.2
Shock	MIL STD 810C 516.2
Noise Immunity	NEMA ICS3-304
Weight	136g

Input Range Resolution	
-20 to 20mA	-8192 to 8191 counts
0–20 mA	0–8191 counts
4–20 mA	1638–8191 counts

Wiring & Dimensions

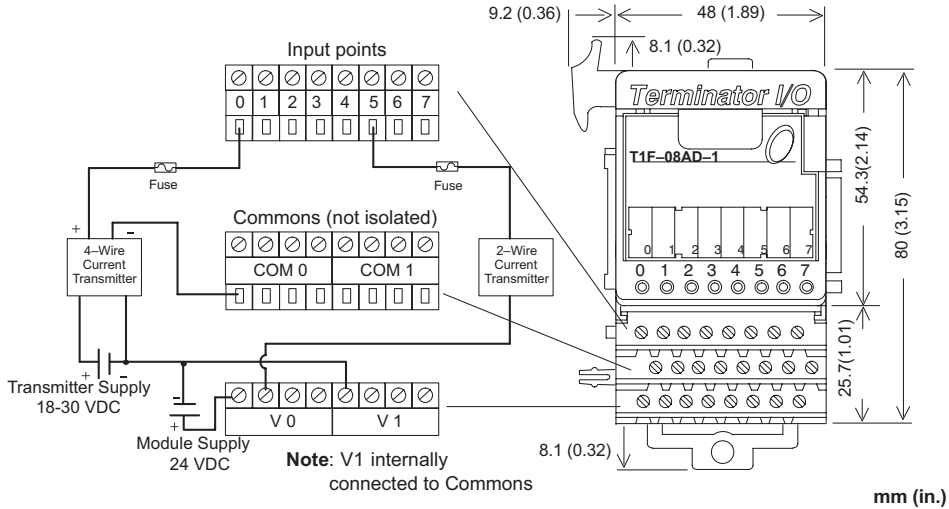

NOTES:

1. Shields should be grounded at the signal source.
2. More than one external power supply can be used, provided all the power supply commons are connected.
3. A Series 217, 0.032 A fast-acting fuse is recommended for 4–20 mA current loops.
4. If the power supply common of an external power supply is not connected to the 0V terminal on the module, then the output of the external transmitter must be isolated. To avoid “ground loop” errors, recommended 4–20 mA transmitter types are:
 - For 2 or 3 wire connections: Isolation between the input supply signal and the power supply.
 - For 4 wire connections: Isolation between the input supply signal, the power supply and the 4–20 mA output.

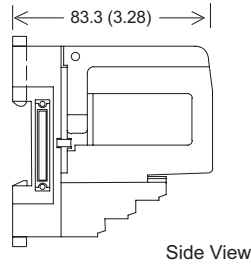

Equivalent Input Circuit

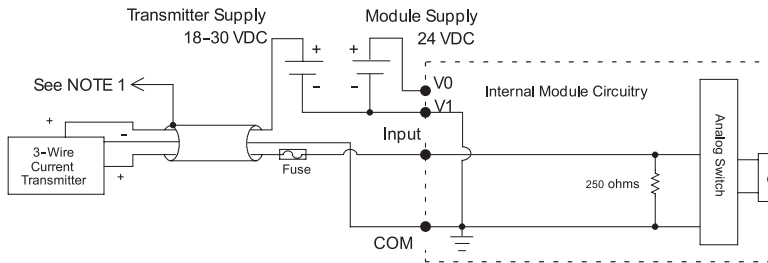

Input Signal Ranges



T1F-08AD-2 8-Channel Voltage Analog Input

Specifications	
Number of Channels	8, single ended (1 common)
Input Ranges	0–5 V, 0–10 V, $\pm 5V$, $\pm 10V$
Resolution	14 bit (13 bit plus sign bit)
Frequency Response	- 3db @ 500Hz, - 20db / decade
Input Resistance	200k Ω min.
Absolute Maximum Ratings	Fault Protected Input, 130V (rms) or 100VDC
Conversion Time (Default: Normal Mode)	Normal Mode: 5ms per channel Fast Mode: 0.5 ms per channel (Fast Mode supported in module hardware version B or later, and only when using this analog module with the T1H-EBC(100) or T1H-PBC control module)
Linearity Error	± 2 count max.
Input Stability	± 1 count
Calibration Full Scale Error	8 counts max.
Calibration Offset Error	2 counts max.
Max. Full Scale Inaccuracy (% of full scale); all errors included	0.08% @ 25°C 0.26% @ 60°C
Master Update Rate	8 channels per scan max.
Input Points Required	256 discrete pts. or 8 dwords (d (double) word = 32 bit word) Network Interface dependent
Base Power Required	75mA @ 5VDC
External Module Power Supply Req.	18–30VDC, 50mA, class 2
Operating Temperature	0° to 60°C (32° to 140°F)
Storage Temperature	- 20° to 70°C (- 4° to 158°F)
Accuracy vs. Temperature	± 50 ppm / °C max. full scale
Relative Humidity	5 to 95% (non-condensing)
Environmental Air	No corrosive gases permitted
Vibration	MIL STD 810C 514.2
Shock	MIL STD 810C 516.2
Noise Immunity	NEMA ICS3-304
Weight	136g

Input Range Resolution	
0–5 V	0–4095 counts
0–10 V	0–8191 counts
$\pm 5V$	- 4095 to 4095 counts
$\pm 10V$	-8192 to 8191 counts

Wiring & Dimensions

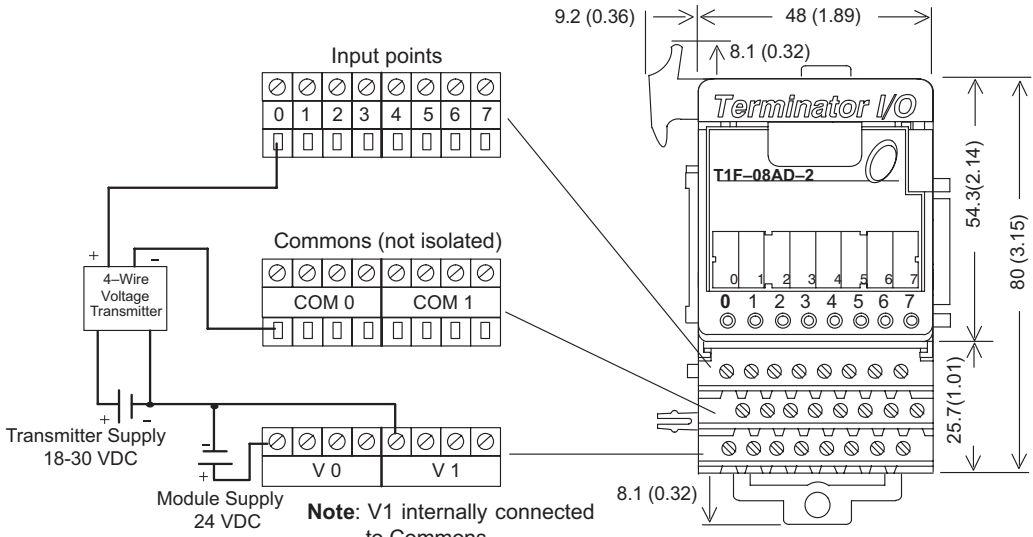

mm (in.)

NOTES:

1. Shields should be grounded at the signal source.
2. Unused inputs should be connected to Common (0 VDC).
3. More than one external power supply can be used, provided all the power supply commons are connected.

Input Signal Ranges

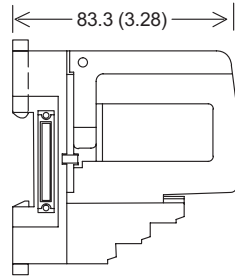
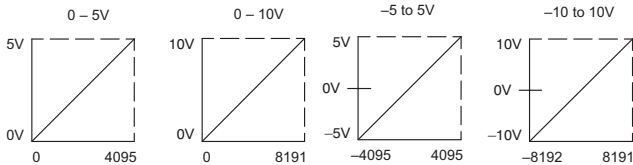

Side View

Equivalent Input Circuit

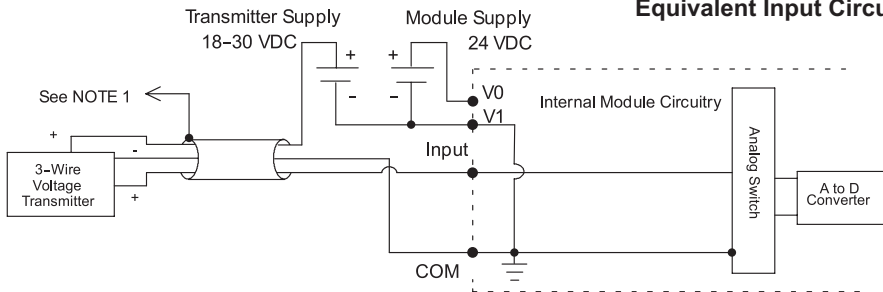

T1F-16AD-1 16-Channel Current Analog Input

Specifications	
Number of Channels	16, single ended (1 common)
Input Ranges	0–20 mA, 4–20 mA, - 20 to 20mA
Resolution	14 bit (13 bit plus sign bit)
Frequency Response	- 3db @ 500Hz, - 20db / decade
Input Resistance	250Ω
Absolute Maximum Ratings	8V max. Input
Conversion Time	5ms per channel
Linearity Error	±2 count max.
Input Stability	±1 count
Full Scale Error (Offset Error not included)	16 counts max.
Offset Error	2 counts max.
Max. Full Scale Inaccuracy (% of full scale); all errors included	0.18% @ 25°C 0.36% @ 60°C
Master Update Rate	16 channels per scan max.
Input Points Required	512 discrete pts. or 16 dwords (d (double) word = 32 bit word) Network Interface dependent
Base Power Required	75mA @ 5VDC
External Module Power Supply Req.	18–30 VDC, 50mA, class 2
Recommended Fuse	0.032 A @ 5VDC
Operating Temperature	0°to 60°C (32°to 140°F)
Storage Temperature	- 20°to 70°C (- 4°to 158°F)
Accuracy vs. Temperature	±50ppm / °C max. full scale
Relative Humidity	5 to 95% (non-condensing)
Environmental Air	No corrosive gases permitted
Vibration	MIL STD 810C 514.2
Shock	MIL STD 810C 516.2
Noise Immunity	NEMA ICS3-304
Weight	168g

Input Range Resolution	
-20 to 20mA	-8192 to 8191 counts
0–20 mA	0–8191 counts
4–20 mA	1638–8191 counts

Wiring & Dimensions

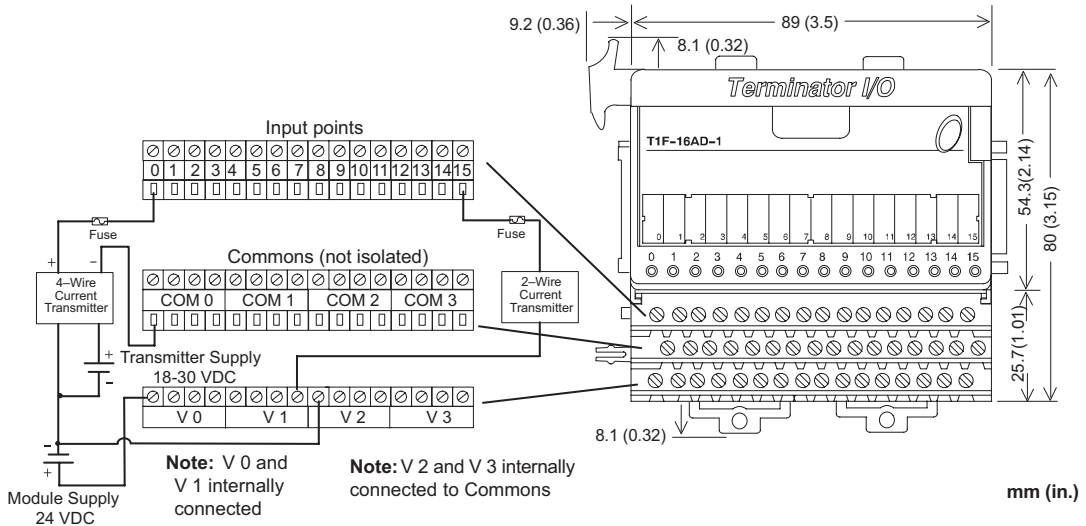

NOTES:

1. Shields should be grounded at the signal source.
2. More than one external power supply can be used, provided all the power supply commons are connected.
3. A Series 217, 0.032 A fast-acting fuse is recommended for 4–20 mA current loops.
4. If the power supply common of an external power supply is not connected to the 0 V terminal on the module, then the output of the external transmitter must be isolated. To avoid “ground loop” errors, recommended 4–20 mA transmitter types are:
 - For 2 or 3 wire connections: Isolation between the input supply signal and the power supply.
 - For 4 wire connections: Isolation between the input supply signal, the power supply and the 4–20 mA output.

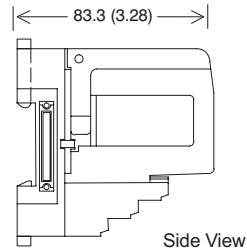

Equivalent Input Circuit

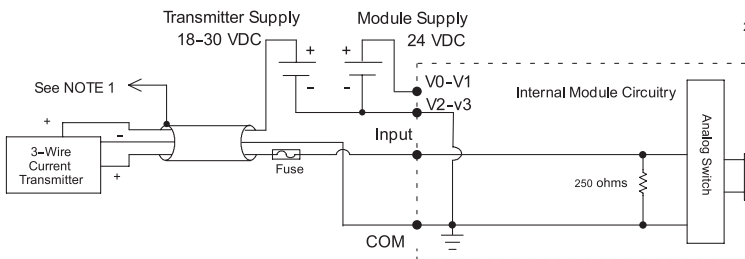

Input Signal Ranges

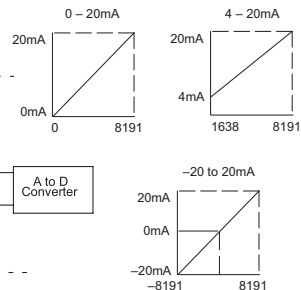

T1F-16AD-2 16-Channel Voltage Analog Input

Specifications	
Number of Channels	16, single ended (1 common)
Input Ranges	0–5 V, 0–10 V, $\pm 5V$, $\pm 10V$
Resolution	14 bit (13 bit plus sign bit)
Frequency Response	- 3db @ 500Hz, - 20db / decade
Input Resistance	200k Ω min.
Absolute Maximum Ratings	Fault Protected Input, 130V (rms) or 100VDC
Conversion Time	5ms per channel
Linearity Error	± 2 count max.
Input Stability	± 1 count
Calibration Full Scale Error	8 counts max.
Calibration Offset Error	2 counts max.
Max. Full Scale Inaccuracy (% of full scale); all errors included	0.08% @ 25°C 0.26% @ 60°C
Master Update Rate	16 channels per scan max.
Input Points Required	512 discrete pts. or 16 dwords (d (double) word = 32 bit word) Network Interface dependent
Base Power Required	75mA @ 5VDC
External Module Power Supply Req.	21.6–26.4 VDC, 50mA, class 2
Operating Temperature	0° to 60°C (32° to 140°F)
Storage Temperature	- 20° to 70°C (- 4° to 158°F)
Accuracy vs. Temperature	± 50 ppm / °C max. full scale
Relative Humidity	5 to 95% (non-condensing)
Environmental Air	No corrosive gases permitted
Vibration	MIL STD 810C 514.2
Shock	MIL STD 810C 516.2
Noise Immunity	NEMA ICS3-304
Weight	160g

Input Range Resolution	
0–5 V	0–4095 counts
0–10 V	0–8191 counts
$\pm 5V$	- 4095 to 4095 counts
$\pm 10V$	-8192 to 8191 counts

Wiring & Dimensions

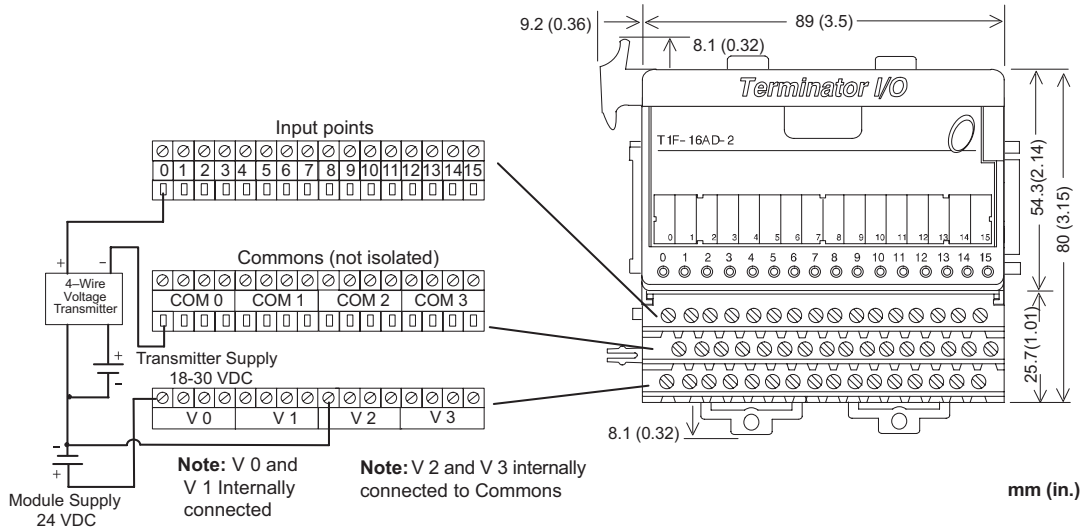

NOTES:

1. Shields should be grounded at the signal source.
2. Unused inputs should be connected to Common (0 VDC).
3. More than one external power supply can be used, provided all the power supply commons are connected.

Input Signal Ranges

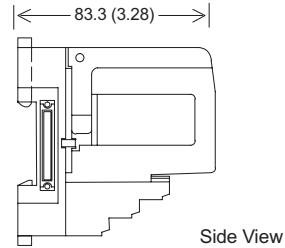
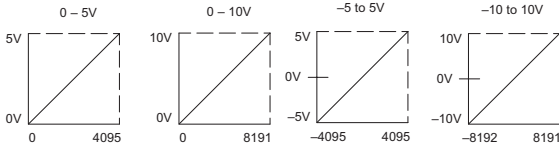

Equivalent Input Circuit

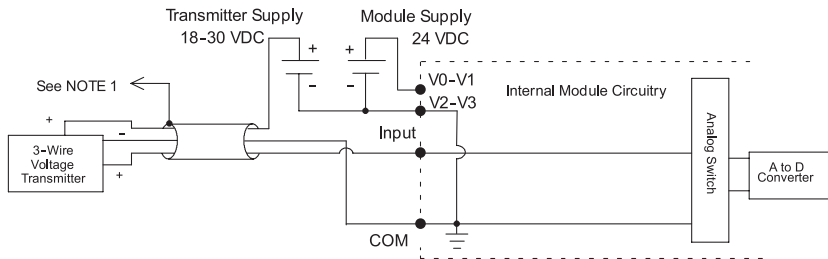

T1F-08DA-1 8-Channel Current Analog Output

Specifications	
Number of Channels	8
Output Ranges	0-20 mA, 4-20 mA
Output Type	Single ended, 1 common
Resolution	12 bit (1 in 4096)
Max. Loop Supply	30VDC
Peak Output Voltage	30VDC
Load Impedance	0 Ω min.
Max. Load (ohm) / Power Supply	620 / 18V, 910 / 24V, 1200 / 30V
Min. Load (ohm) / Power Supply*	0 / 24V, 350 / 30V @ 40°C 250 / 24V, 600 / 30V @ 60°C
Linearity Error (end to end)	± 2 counts max. $\pm 0.05\%$ of full scale max.
Conversion Settling Time	400 μ s max. full scale change
Full Scale Calibration Error	± 12 counts max.
Offset Calibration Error	0-20 mA: ± 5 counts max. 4-20 mA: ± 6 counts max.
Accuracy vs. Temperature	± 50 ppm / °C, full scale calibration change
Max. Full Scale Inaccuracy (% of full scale) all errors included	0.2% @ 25°C 0.4% @ 60°C
Master Update Rate	8 channels per scan max.
Output Points Required	256 discrete pts. or 8 dwords (d (double) word = 32 bit word) Network Interface dependent
Base Power Required	75mA @ 5VDC
External Module Power Supply Req.	21.6-26.4 VDC, 150mA, class 2
Operating Temperature	0° to 60°C (32° to 140°F)
Storage Temperature	- 20° to 70°C (- 4° to 158°F)
Relative Humidity	5 to 95% (non-condensing)
Environmental Air	No corrosive gases permitted
Vibration	MIL STD 810C 514.2
Shock	MIL STD 810C 516.2
Noise Immunity	NEMA ICS3-304
Weight	145g

*Max. allowable output power dissipation. For example, at 60°C and 24VDC, there must be a load of at least 250 Ω on the output circuit. Smaller loads will damage the analog output circuit.



NOTE: This module requires software setup via the Module Control Byte. Refer to Chapter 4 in this manual.

Wiring & Dimensions

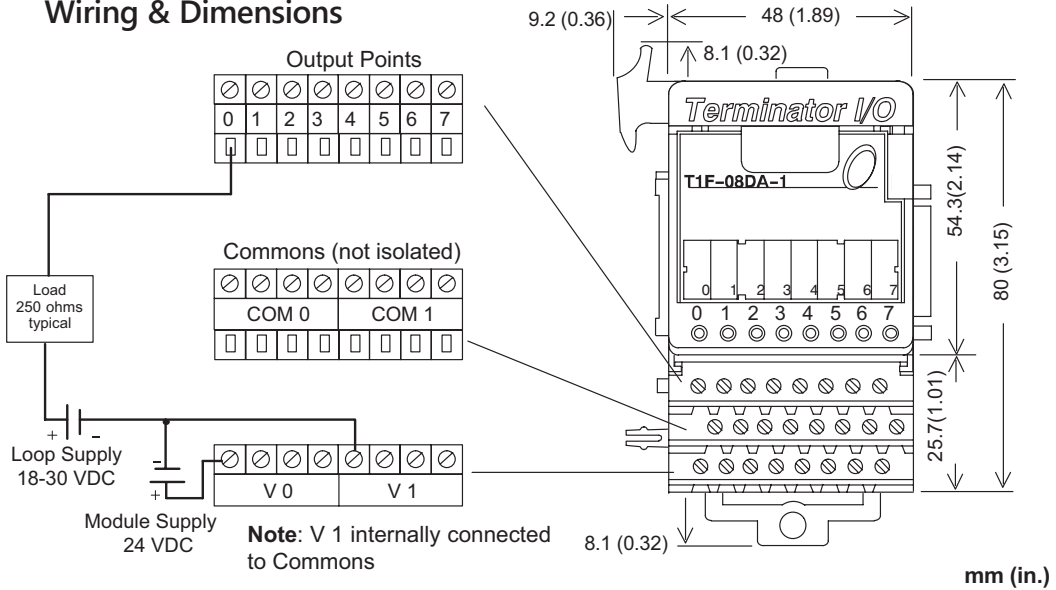

NOTES:

1. Shields should be connected to the 0 V terminal of the module or the 0 V of the power supply.
2. Unused current outputs should remain open (no connections) for minimum power consumption.

Output Signal Ranges

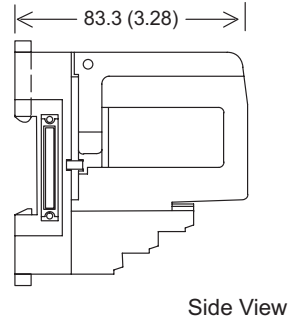
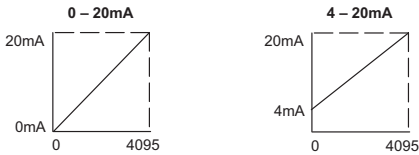

Equivalent Output Circuit

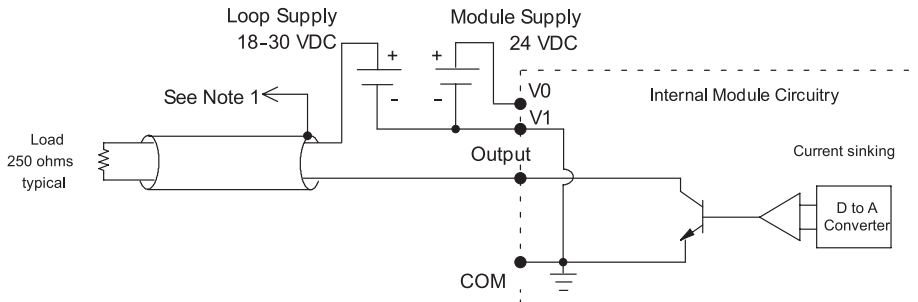

T1F-08DA-2 8-Channel Analog Output

Specifications	
Number of Channels	8
Output Ranges	0-5 V, 0-10 V, $\pm 5V$, $\pm 10V$
Output Type	Single ended, 1 common
Resolution	12 bit (1 in 4096)
Peak Output Voltage	15VDC
Load Impedance	4k Ω min.
Load Capacitance	0.01 μF max.
Linearity Error (end to end)	± 2 counts max. $\pm 0.05\%$ of full scale max.
Conversion Settling Time	100 μs max. full scale change
Full Scale Calibration Error	± 12 counts max.
Offset Calibration Error	10V ranges: ± 6 counts max. 5V ranges: ± 11 counts max.
Accuracy vs. Temperature	± 50 ppm / $^{\circ}C$, full scale calibration change
Max. Full Scale Inaccuracy (% of full scale) all errors and temp drift included	10V ranges: $\pm 0.2\%$ @ 25 $^{\circ}C$ $\pm 0.4\%$ @ 60 $^{\circ}C$ 5V ranges: $\pm 0.3\%$ @ 25 $^{\circ}C$ $\pm 0.5\%$ @ 60 $^{\circ}C$
Master Update Rate	8 channels per scan max.
Output Points Required	256 discrete pts. or 8 dwords (d (double) word = 32 bit word) Network Interface dependent
Base Power Required	75mA @ 5VDC
External Module Power Supply Req.	21.6 - 26.4VDC, 150mA, class 2
Operating Temperature	0 $^{\circ}$ to 60 $^{\circ}C$ (32 $^{\circ}$ to 140 $^{\circ}F$)
Storage Temperature	- 20 $^{\circ}$ to 70 $^{\circ}C$ (- 4 $^{\circ}$ to 158 $^{\circ}F$)
Relative Humidity	5 to 95% (non-condensing)
Environmental Air	No corrosive gases permitted
Vibration	MIL STD 810C 514.2
Shock	MIL STD 810C 516.2
Noise Immunity	NEMA ICS3-304
Weight	145g



NOTE: This module requires software setup via the Module Control Byte. Refer to Chapter 4 in this manual.

Wiring & Dimensions

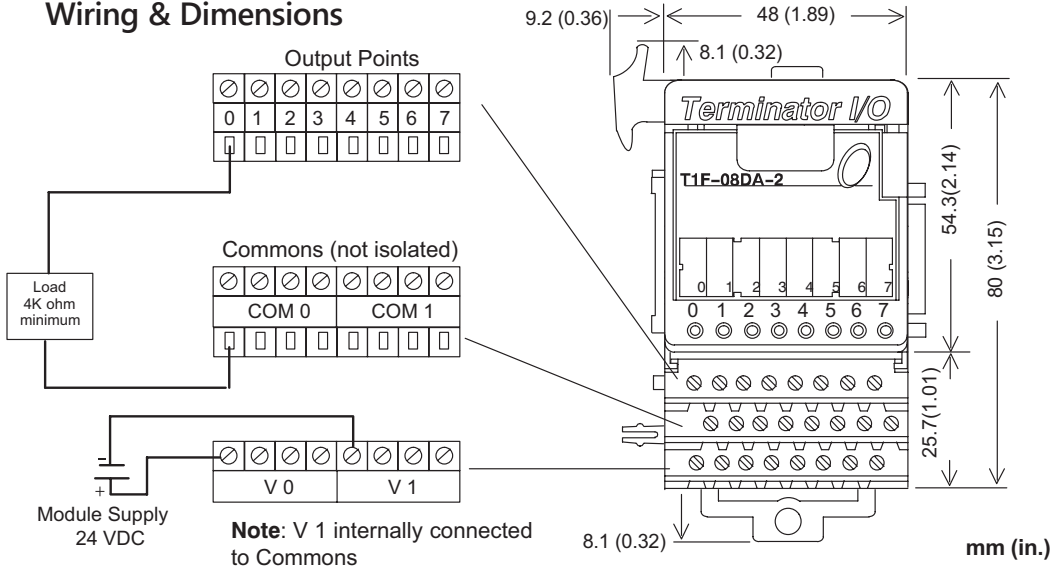

NOTES:

1. Shields should be connected to the 0 V terminal of the module or the 0 V terminal of the power supply.
2. Unused voltage outputs should remain open (no connections) for minimum power consumption.

Unipolar Ranges

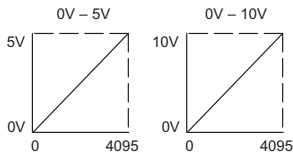

Bipolar Ranges

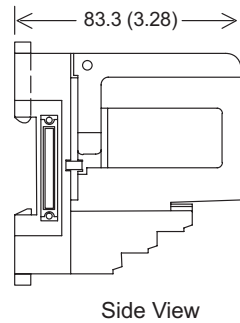
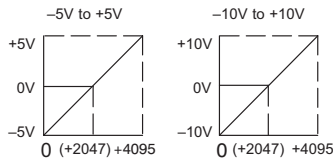

Equivalent Output Circuit

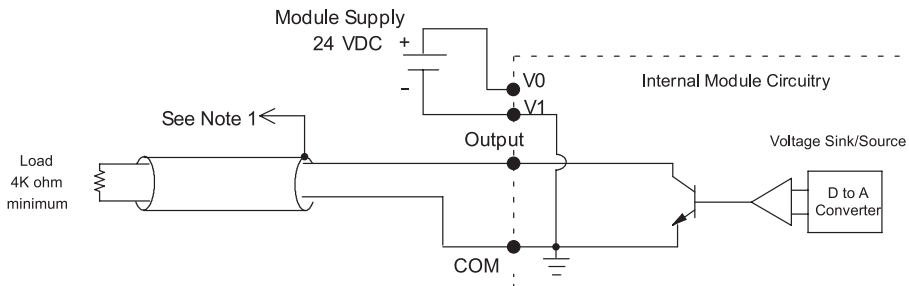

T1F-16DA-1 16-Channel Current Analog Output

Specifications	
Number of Channels	16
Output Ranges	0–20 mA, 4–20 mA
Output Type	Single ended, 1 common
Resolution	12 bit (1 in 4096)
Max. Loop Supply	30VDC
Peak Output Voltage	30VDC
Max. Load (ohm) / Power Supply	620 / 18V, 910 / 24V, 1200 / 30V
Min. Load (ohm) / Power Supply*	0 / 24V, 350 / 30 V @ 40°C 250 / 24V, 600 / 30V @ 60°C
Linearity Error (end to end)	±2 counts max. ±0.05% of full scale max.
Conversion Settling Time	400µs max. full scale change
Full Scale Calibration Error	±12 counts max.
Offset Calibration Error	0–20mA: ±5 counts max. 4–20mA: ±6 counts max.
Accuracy vs. Temperature	±50ppm / °C, full scale calibration change
Max. Full Scale Inaccuracy (% of full scale) all errors included	0.2% @ 25°C 0.4% @ 60°C
Master Update Rate	16 channels per scan max.
Output Points Required	512 discrete pts. or 16 dwords (d (double) word = 32 bit word) Network Interface dependent
Base Power Required	75mA @ 5VDC
External Module Power Supply Req.	21.6–26.4 VDC, 150mA, class 2
Operating Temperature	0° to 60°C (32° to 140°F)
Storage Temperature	- 20° to 70°C (- 4° to 158°F)
Relative Humidity	5 to 95% (non-condensing)
Environmental Air	No corrosive gases permitted
Vibration	MIL STD 810C 514.2
Shock	MIL STD 810C 516.2
Noise Immunity	NEMA ICS3-304
Weight	172g

*Max. allowable output power dissipation. For example, at 60°C and 24VDC, there must be a load of at least 250Ω on the output circuit. Smaller loads will damage the analog output circuit.



NOTE: This module requires software setup via the Module Control Byte. Refer to Chapter 4 in this manual.

Wiring & Dimensions

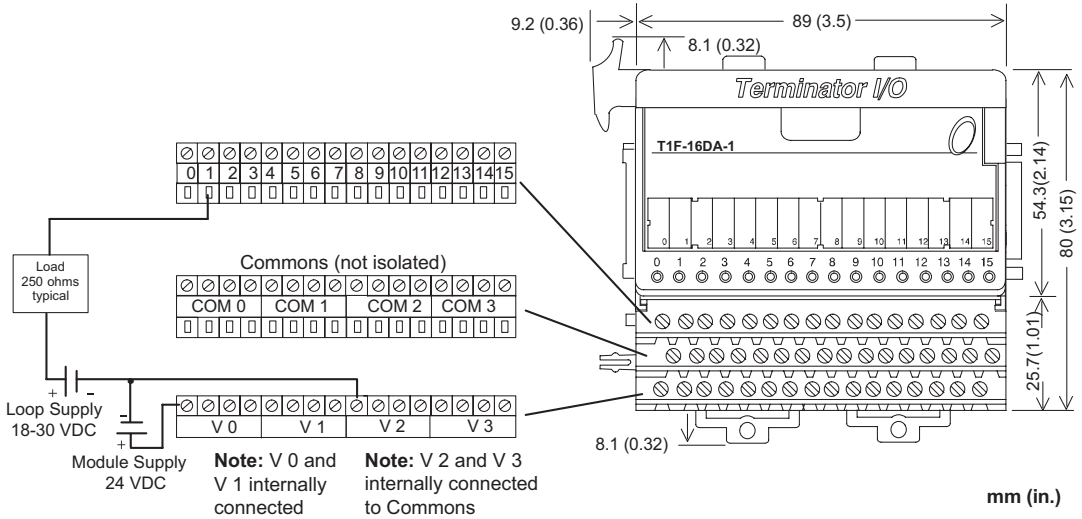

NOTES:

1. Shields should be connected to the 0 V terminal of the module or the 0 V of the power supply.
2. Unused current outputs should remain open (no connections) for minimum power consumption.

Output Signal Ranges

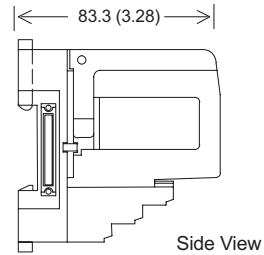
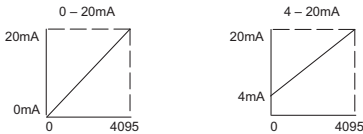

Equivalent Output Circuit

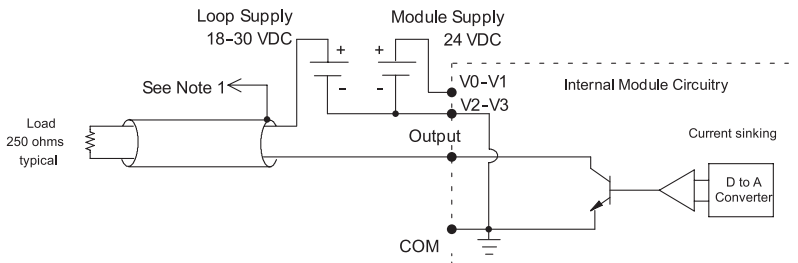

T1F-16DA-2 16-Channel Voltage Analog Output

Specifications	
Number of Channels	16
Output Ranges	0–5 V, 0–10 V, $\pm 5V$, $\pm 10V$
Output Type	Single ended, 1 common
Resolution	12 bit (1 in 4096)
Peak Output Voltage	15VDC
Load Impedance	4k Ω min.
Load Capacitance	0.01 μF max.
Linearity Error (end to end)	± 2 counts max. $\pm 0.05\%$ of full scale max.
Conversion Settling Time	100 μs max. full scale change
Full Scale Calibration Error	± 12 counts max.
Offset Calibration Error	10V ranges: ± 6 counts max. 5V ranges: ± 11 counts max.
Accuracy vs. Temperature	± 50 ppm / $^{\circ}C$, full scale calibration change
Max. Full Scale Inaccuracy (% of full scale) all errors and temp drift included	10V ranges: $\pm 0.2\%$ @ 25 $^{\circ}C$ $\pm 0.4\%$ @ 60 $^{\circ}C$ 5V ranges: $\pm 0.3\%$ @ 25 $^{\circ}C$ $\pm 0.5\%$ @ 60 $^{\circ}C$
Master Update Rate	16 channels per scan max.
Output Points Required	512 discrete pts. or 16 dwords (d (double) word = 32 bit word) Network Interface dependent
Base Power Required	75mA @ 5VDC
External Module Power Supply Req.	21.6–26.4VDC, 150mA, class 2
Operating Temperature	0 $^{\circ}$ to 60 $^{\circ}C$ (32 $^{\circ}$ to 140 $^{\circ}F$)
Storage Temperature	- 20 $^{\circ}$ to 70 $^{\circ}C$ (- 4 $^{\circ}$ to 158 $^{\circ}F$)
Relative Humidity	5 to 95% (non-condensing)
Environmental Air	No corrosive gases permitted
Vibration	MIL STD 810C 514.2
Shock	MIL STD 810C 516.2
Noise Immunity	NEMA ICS3-304
Weight	172g



NOTE: This module requires software setup via the Module Control Byte. Refer to Chapter 4 in this manual.

Wiring & Dimensions

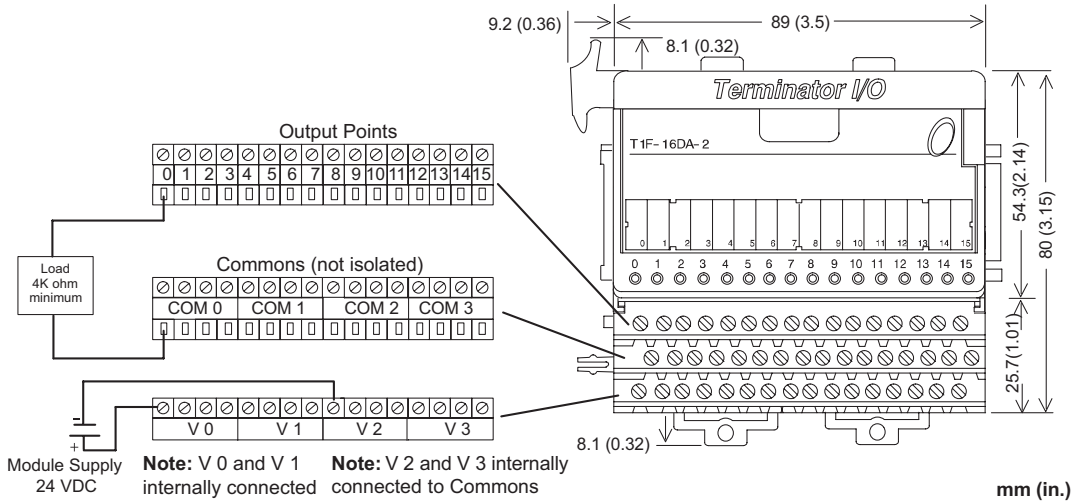

NOTES:

1. Shields should be connected to the 0 V terminal of the module or the 0 V of the power supply.
2. Unused voltage outputs should remain open (no connections) for minimum power consumption.

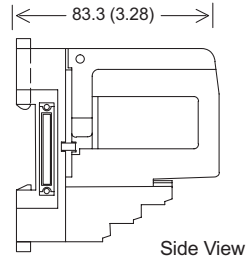
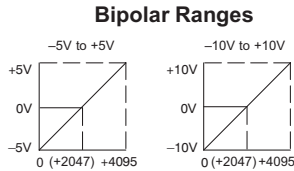
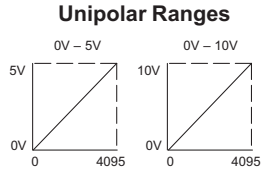

Equivalent Output Circuit

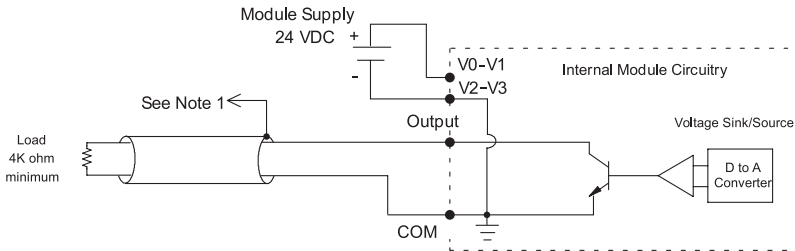

T1F-16RTD RTD Input Module

Specifications	
Number of Channels	16
Resolution	±0.1°C or °F
Common Mode Range	0-5 VDC
Notch Filter	> 50 db notches @ 50/60 Hz; f - 3db = 13.1 Hz
Absolute Max. Ratings	±50VDC
Converter Type	Charge balancing, 24 - bit
Sampling Rate	140ms / channel
Master Update Rate	16 channels per scan
Input Points Required	512 discrete pts. or 16 dwords (d (double) word = 32 bit word) Network Interface dependent
Base Power Required	150mA @ 5VDC
Operating Temperature	0° to 60°C (32° to 140°F)
Temperature Drift	25 ppm / °C (max.)
Maximum Inaccuracy	±1°C
RTD Excitation Current	200µA
Relative Humidity	5 to 95% (non-condensing)
Environmental Air	No corrosive gases permitted
Vibration	MIL STD 810C 514.2
Shock	MIL STD 810C 516.2
Noise Immunity	NEMA ICS3-304
Weight	168g

RTD Input Ranges	
RTD Type	Range
Pt100	-200°C to 850°C (-328°F to 1562°F)
Pt1000	-200°C to 595°C (-328°F to 1103°F)
jPt100	-38°C to 450°C (-36°F to 842°F)
Type CU - 10 / 25	-200°C to 260°C (-328°F to 500°F)
120Ω Nickel	-80°C to 260°C (-112°F to 500°F)

Wiring & Dimensions

Note: Apply the labels that come with the I/O module to the I/O base terminals to properly identify the base terminal points. Also, the CJC sense unit must be installed to the I/O base. (see wiring diagram below)

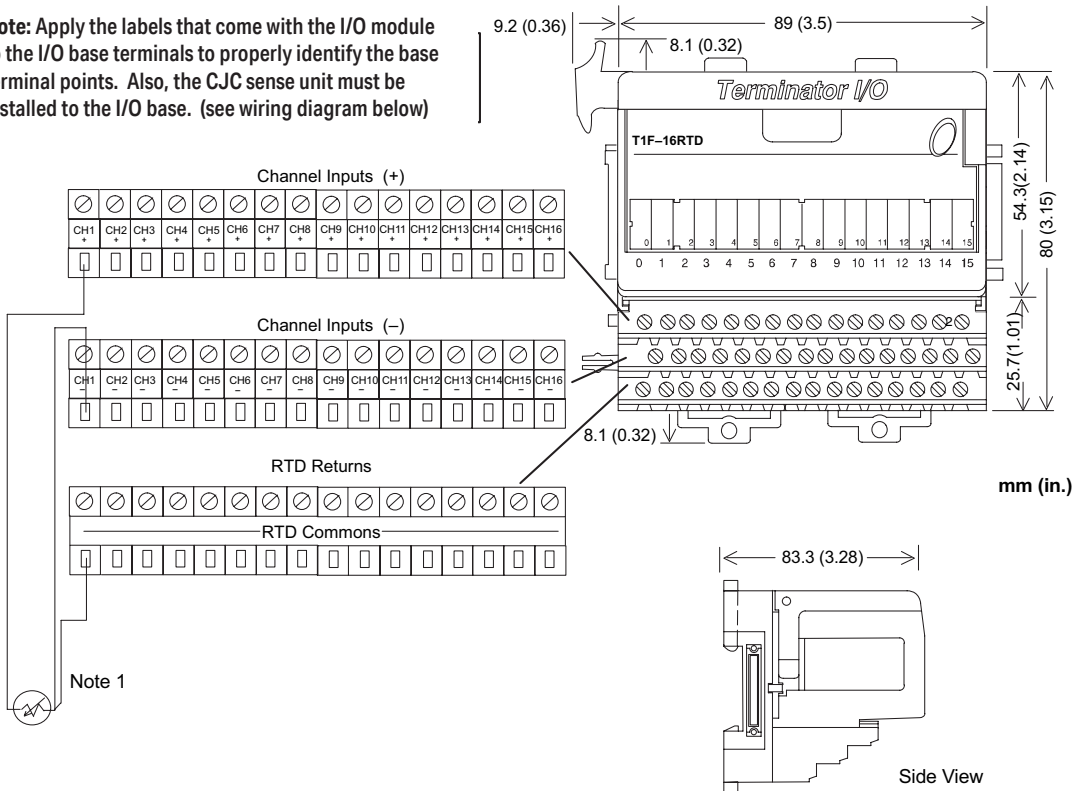

Notes:

1. The three wires connecting the RTD to the module must be the same type and length. Do not use the shield or drain wire for the third connection.
2. If an RTD sensor has four wires, the plus sense wire should be left unconnected as shown.

Equivalent Input Circuit

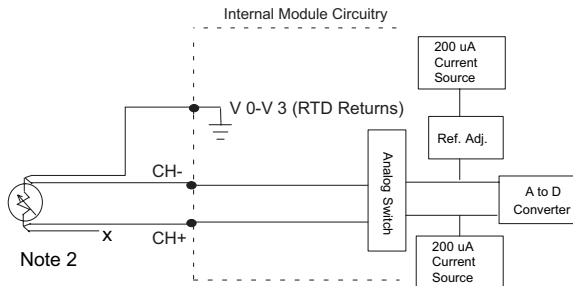

T1F-16RTD continued

Setting Module Jumpers

Select Number of Channels (see Note 1)

Number of Channels	Jumper			
	CH+1	CH+2	CH+3	CH+4
1				
2	X			
3		X		
4	X	X		
5			X	
6	X		X	
7		X	X	
8	X	X	X	
9				X
10	X			X
11		X		X
12	X	X		X
13			X	X
14	X		X	X
15		X	X	X
16	X	X	X	X

X = Jumper Installed

Blank Space = Jumper Removed

Select Input Type (see Note 2)

RTD Input	Jumper		
	RTD-0	RTD-1	RTD-2
Pt100Ω	X	X	
Pt1000Ω			X
jPt100Ω		X	
Type CU-10Ω			
Type CU-25Ω	X		
120Ω Nickel	X		X

X = Jumper Installed

Blank Space = Jumper Removed

NOTE 1: The module comes from the factory with all of the Number of Channels jumpers installed for sixteen channel operation. Use the table to determine the proper settings for your application.

NOTE 2: The module comes from the factory with the input Type jumpers selected for Pt100Ω operation. Use the table to determine the proper settings for your application.



Jumpers Located Under Module Top Cover

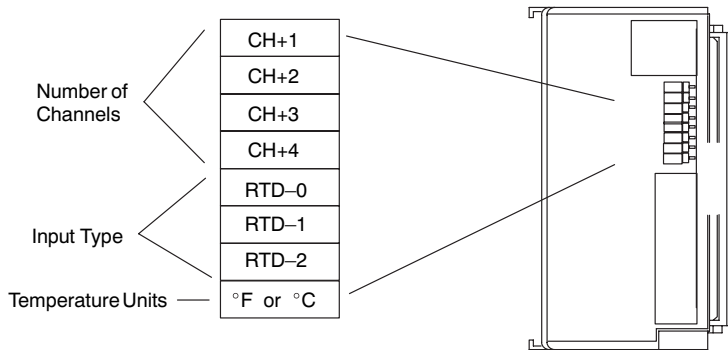

Select Temperature Units

Temperature Units	Jumper
°F	X
°C	

X = Jumper Installed,
Blank Space = Jumper Removed

T1F-RTD Data Format

The data format for each of the 16 RTD input channels consists of 32 bits. Only one bit is used in bits D31–D16 (bit 24) as shown below.

31	30	29	28	27	26	25	24	23	22	21	20	19	18	17	16
-	-	-	-	-	-	-	B0	-	-	-	-	-	-	-	-

Bit 24, designated as B0, is the channel burn out bit:

- 1 = channel RTD sensor burn out or RTD is disconnected from either input terminal
- 0 = channel is okay.

The remaining bits (–) are not used and are all equal to 0.

D15–D0, shown below, contains the temperature data with D15 being the most significant bit (MSB). The temperature data has one implied decimal, so the readings are in tenths of degrees. Negative temperature readings are represented in 2’s complement format.

15	14	13	12	11	10	9	8	7	6	5	4	3	2	1	0
D15	D14	D13	D12	D11	D10	D9	D8	D7	D6	D5	D4	D3	D2	D1	D0

T1F-16TMST Thermistor Input Module (Retired)



* Note: T1F-16TMST was discontinued 08/2025; no replacement available.

Specifications	
Number of Channels	16
Resolution	±0.1°C or °F
Input Impedance	> 1MΩ
Common Mode Range	0-5 VDC
Absolute Max. Ratings	±50VDC
Converter Type	Charge balancing, 24-bit
Sampling Rate	140ms / channel
Master Update Rate	16 channels per scan max.
Input Points Required	512 discrete pts. or 16 dwords (d (double) word = 32 bit word) Network Interface dependent
Base Power Required	150mA @ 5VDC
Operating Temperature	0°C to 60°C (32°F to 140°F)
Storage Temperature	-20°C to 70°C (-4°F to 158°F)
Temperature Drift	25ppm / °C (max.)
Maximum Inaccuracy ¹	±1°C
Excitation Current	10μA
Electrical Isolation	1500VDC field wire to backplane
Relative Humidity	5 to 95% (non-condensing)
Environmental Air	No corrosive gases permitted
Vibration	IEC 60068-2-6 (Test FC)
Shock	IEC 60068-2-27 (Test Ea)
Noise Immunity	EN61131-2:2007 ²
Recommended Cable	AutomationDirect P/N: PLTC3-18-1S-XXX Belden 8761 or equivalent
Weight	168g

¹ "Accuracy" pertains to module only and does not include tolerances of thermistor element, wiring resistance, etc. For example, 22 gauge wire is 0.016 Ω per foot, so 200 feet of wire adds 3.2 Ω.

² Meets EMC & Safety Requirements

Thermistor Input Ranges	
Input Ranges	Range
10K-AN (Type 3)	-40°C to 150°C (-40°F to 300°F)
10K-CP (Type 2)	-40°C to 150°C (-40°F to 300°F)
5K	-40°C to 150°C (-40°F to 300°F)
3K	-40°C to 150°C (-40°F to 300°F)
2252	-40°C to 150°C (-40°F to 300°F)
1.8K	-40°C to 150°C (-40°F to 300°F)

Wiring & Dimensions

Note: Apply the labels that come with the I/O module to the I/O base terminals to properly identify the base terminal points.

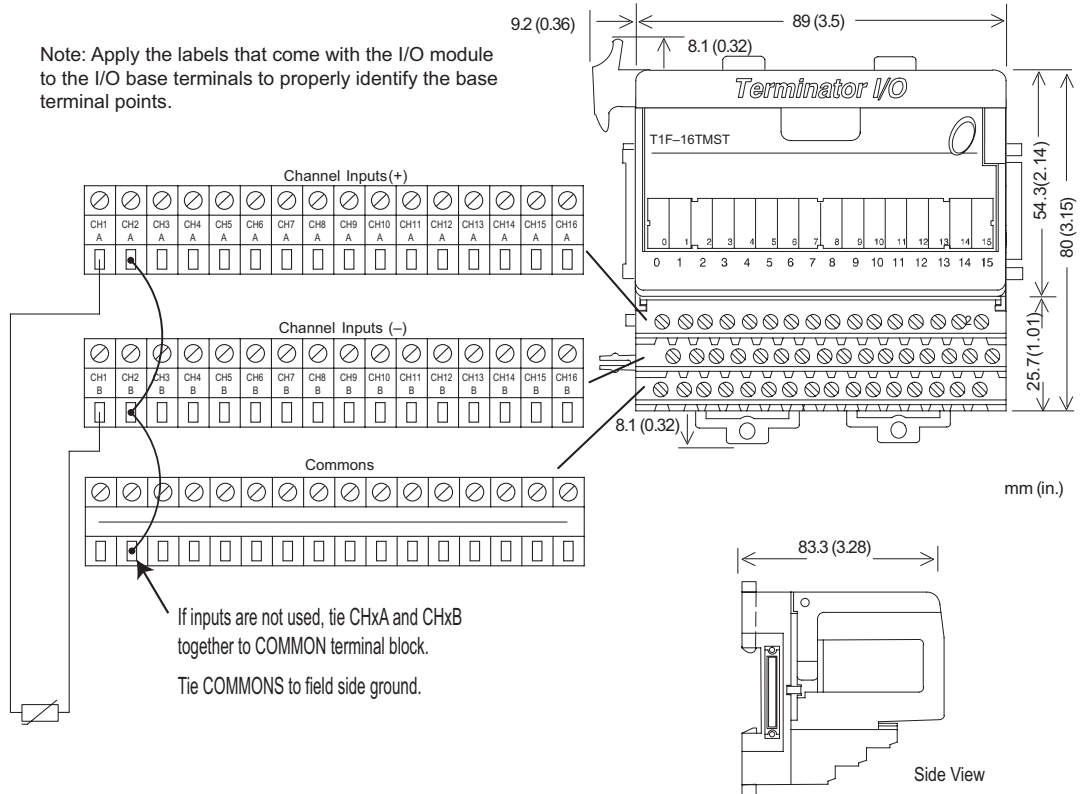

Equivalent Input Circuit

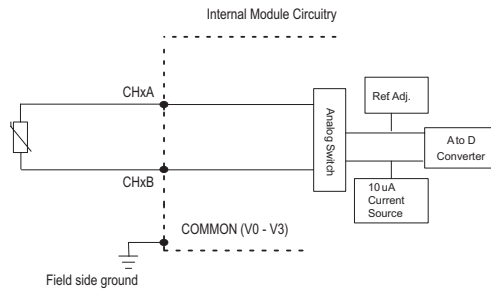

T1F-16TMST continued (retired)

Setting Module Jumpers

Select Number of Channels (see Note 1)

Number of Channels	Jumper			
	CH+1	CH+2	CH+3	CH+4
1				
2	X			
3		X		
4	X	X		
5			X	
6	X		X	
7		X	X	
8	X	X	X	
9				X
10	X			X
11		X		X
12	X	X		X
13			X	X
14	X		X	X
15		X	X	X
16	X	X	X	X

X = Jumper Installed

Blank Space = Jumper Removed

Select Input Type (see Note 2)

Thermistor Input	Jumper		
	TMST-0	TMST-1	TMST-2
10K-AN (Type 3)			
10K-CP (Type 2)	X		
5K		X	
3K	X	X	
2252			X
1.8K	X		X
Future use		X	X
Future use	X	X	X

X = Jumper Installed

Blank Space = Jumper Removed



NOTE 1: The module comes from the factory with all of the Number of Channels jumpers installed for sixteen channel operation. Use the table to determine the proper settings for your application.

NOTE 2: The module comes from the factory with the Input Type jumpers selected for 10K-AN operation. Use the table to determine the proper settings for your application.

Jumpers Located Under Module Top Cover

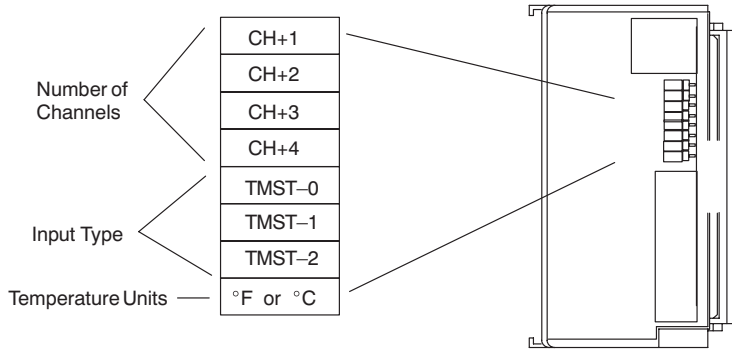

Select Temperature Units

Temperature Units	Jumper
°F	X
°C	

X = Jumper Installed,
Blank Space = Jumper Removed

T1F-TMST Data Format

The data format for each of the 16 TMST input channels consists of 32 bits. Only one bit is used in bits D31–D16 (bit 24) as shown below.

31	30	29	28	27	26	25	24	23	22	21	20	19	18	17	16
-	-	-	-	-	-	-	B0	-	-	-	-	-	-	-	-

Bit 24, designated as B0, is the channel burn out bit:

- 1 = channel thermistor sensor burn out or thermistor is disconnected from either input terminal
- 0 = channel is okay.

The remaining bits (–) are not used and are all equal to 0.

D15–D0, shown below, contains the temperature data with D15 being the most significant bit (MSB). The temperature data has one implied decimal, so the readings are in tenths of degrees. Negative temperature readings are represented in 2’s complement format.

15	14	13	12	11	10	9	8	7	6	5	4	3	2	1	0
D15	D14	D13	D12	D11	D10	D9	D8	D7	D6	D5	D4	D3	D2	D1	D0

T1F-14THM 14-Channel Thermocouple Input

Specifications	
Use with I/O Module Base	T1K-16B screw type terminal base only
Number of Channels	14, differential
Common Mode Range	±5VDC
Common Mode Rejection	90db min. @ DC, 150db min. @ 50/60 Hz
Input Impedance	1MΩ
Absolute Max. Ratings	Fault Protected Input ±50VDC
Master Update Rate	14 channels per scan maximum
Input Points Required	512 discrete pts. or 16 dwords (d (double) word = 32 bit word) Network Interface dependent
Base Power Required	60mA @ 5VDC
External Power Required	24VDC ±5%, 70mA, class 2
Operating Temperature	0° to 60°C (-4° to 158°F)
Storage Temperature	-20° to 70°C (32° to 140°F)
Accuracy vs. Temperature	±5ppm / °C max. full scale
Relative Humidity	5 to 95% (non-condensing)
Environmental Air	No corrosive gases permitted
Vibration	MIL STD 810C 514.2
Shock	MIL STD 810C 516.2
Noise Immunity	NEMA ICS3-304
Weight	168g

Thermocouple Specifications	
Input Ranges	Type J -190°C to 760°C (-310°F to 1400°F)
	Type E -210°C to 1000°C (-346°F to 1832°F)
	Type K -150°C to 1372°C (-238°F to 2502°F)
	Type R 65°C to 1768°C (149°F to 3214°F)
	Type S 65°C to 1768°C (149°F to 3214°F)
	Type T -230°C to 400°C (-382°F to 752°F)
	Type B 529°C to 1820°C (984°F to 3308°F)
	Type N -70°C to 1300°C (-94°F to 2372°F)
	Type C 65°C to 2320°C (149°F to 4208°F)
Display Resolution	±0.1°C or ±0.1°F
Cold Junction Compensation (CJC Part #: T1F-CJC)	Automatic
Conversion Time	100ms per channel
Warm Up Time	30 minutes typical, ±1°C repeatability
Linearity Error	±0.05°C maximum, ±0.01°C typical
Maximum Inaccuracy	±3°C

Wiring & Dimensions

Note: Apply the labels that come with the I/O module to the I/O base terminals to properly identify the base terminal points. Also, the CJC sense unit must be installed to the I/O base (see wiring diagram below).

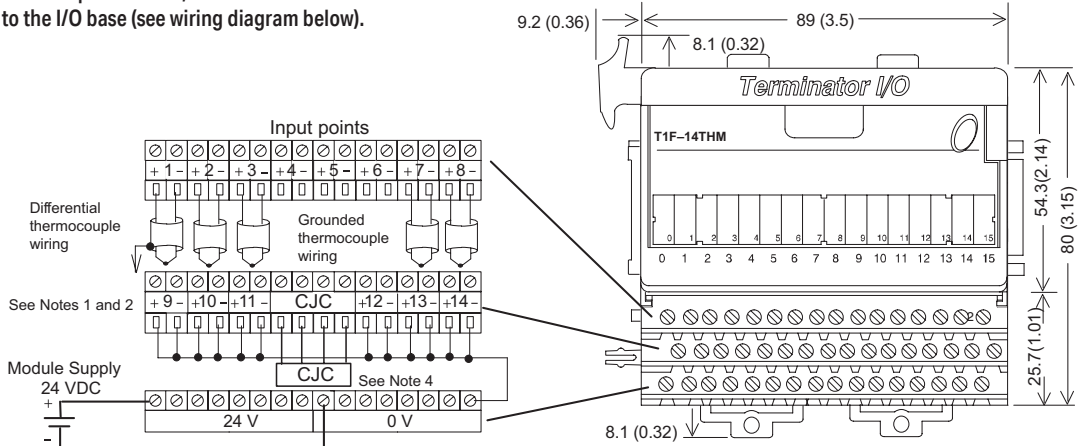

NOTES:

1. Shields should be grounded at the signal source.
2. Unused inputs should be connected to Common (0 VDC).
3. When using 0–156 mV and 5 V ranges, connect (-) or 0 V terminals to 0V to ensure common mode range acceptance
4. The Cold Junction Compensation (part #: T1F–CJC) temperature sense unit that comes with the module must be installed into the I/O base terminals to perform CJC of the thermocouple inputs.

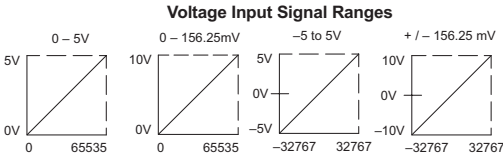

Voltage Specifications	
Input Voltage Ranges	0–5 V, 0–156.25 mV ±5V, ±156.25 mV
Resolution	16 bit (1 in 65535)
Full Scale Calibration Error (Offset Error Included)	±13 counts typical ±33 counts maximum
Offset Calibration Error	±1 count max. @ 0V input
Linearity Error (End to End)	±1 count maximum
Maximum Inaccuracy	±0.02% @ 25°C (77°F)

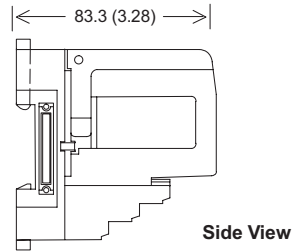

Equivalent Input Circuit

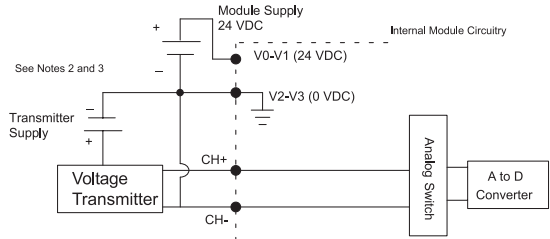

T1F-14THM continued

Setting Module Jumpers

Select Input Type (see Note 3)

Thermocouple/ Voltage Inputs	Jumper			
	T/C Type 0	T/C Type 1	T/C Type 2	T/C Type 3
J	X	X	X	X
K		X	X	X
E	X		X	X
R			X	X
S	X	X		X
T		X		X
B	X			X
N				X
C	X	X	X	
0-5V		X	X	
±5V	X		X	
0-156 mV			X	
±156mV	X	X		

Select the Conversion Units

Jumper	Thermocouple Conversion Units (See Note 4)			
	Magnitude Plus Sign		2's Complement	
	°F	°C	!F	!C
Units-0	X		X	
Units-1	X	X		

Jumper	Voltage Conversion Units (See Note 5)	
	Magnitude Plus Sign	2's Complement
Units-0	X	X
Units-1	X	

X = Jumper Installed
Blank Space = Jumper Removed

T1F-THM Data Format

The data format for each of the 14 thermocouple input channels consists of 32 bits (shown here split into two groups of 16 bits). Only one bit is used in bits D31–D16 (bit 24) as shown below.

31	30	29	28	27	26	25	24	23	22	21	20	19	18	17	16
-	-	-	-	-	-	-	B0	-	-	-	-	-	-	-	-

Bit 24, designated as B0, is the channel burn out bit:

- 1 = channel thermocouple sensor burn out or thermocouple is disconnected from either input terminal
- 0 = channel is okay.

The remaining bits are not used and are all equal to 0 (-).

D15 to D0, shown below, contains the 16-bit temperature data with D15 being the most significant bit (MSB). See Notes 4 and 5.

15	14	13	12	11	10	9	8	7	6	5	4	3	2	1	0
D15	D14	D13	D12	D11	D10	D9	D8	D7	D6	D5	D4	D3	D2	D1	D0

Select Number of Channels (see Note 2)

Number of Channels	Jumper			
	CH+1	CH+2	CH+4	CH+8
1				
2	X			
3		X		
4	X	X		
5			X	
6	X		X	
7		X	X	
8	X	X	X	
9				X
10	X			X
11		X		X
12	X	X		X
13			X	X
14	X		X	X

Jumpers Located Under Module Top Cover

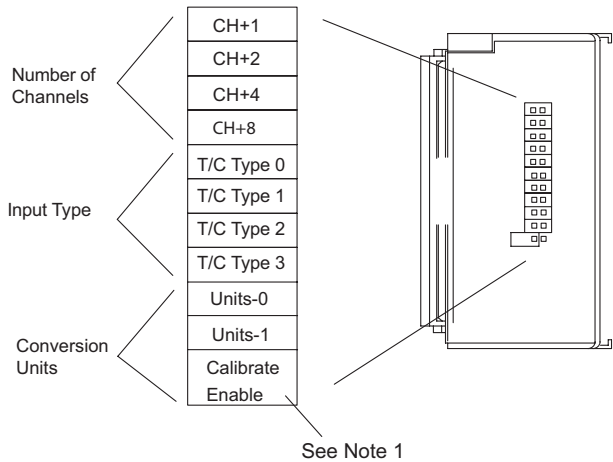

NOTES

Note 1: The Calibrate Enable jumper comes from the factory not installed. Installing the jumper disables the thermocouple active burn-out detection circuitry, which enables a thermocouple calibrator to be connected to the module. To make sure that the output of the thermocouple calibrator is within the 5V common mode voltage range of the module, connect the negative side of the differential voltage input channel to the 0V terminal, then connect the thermocouple calibrator to the differential inputs (for example, Ch 3+ and Ch 3-).

Note 2: The module comes with all of the Number of Channels jumpers installed for fourteen channel operation. Use the table to determine the proper settings.

Note 3: The module comes with all of the Input Type jumpers installed for J type thermocouple operation. Use the table to determine the proper settings.

Note 4: The module comes with the Conversion Units jumpers set for magnitude plus sign with Fahrenheit units selected. All thermocouple types are converted into a direct temperature reading with one implied decimal place. Negative temperatures can be represented in either 2's complement or magnitude plus sign format. If the temperature is negative, the most significant bit is the sign bit. 2's complement data format may be required to correctly display bipolar data on some operator interfaces.

Note 5: The bipolar voltage input ranges may be converted to a 15-bit magnitude plus sign or a 16-bit 2's complement value.

T1F-8AD4DA-1 8-Channel Current Analog Input / 4-Channel Current Analog Output

Input Channel Specifications	
Number of Channels	8, single ended (1 common)
Input Points Required	256 discrete pts. or 8 dwords (d (double) word = 32 bit word) Network Interface dependent
Input Ranges	0–20 mA, 4–20 mA, -20 to 20mA
Resolution	14 bit (13 bit plus sign bit)
Frequency Response Input active low-pass filter	- 3db @ 100Hz, - 20db / decade
Input Resistance	250Ω
Absolute Maximum Ratings	8V max. Input
Conversion Time	5ms per channel
Linearity Error	±2 count max.
Input Stability	±1 count
Full Scale Error (Offset Error not included)	16 counts max.
Offset Error	2 counts max.
Max. Full Scale Inaccuracy (% of full scale); all errors included	0.18% @ 25°C 0.36% @ 60°C
Recommended Fuse	0.032 A, Series 217 Fast Acting

Input Range Resolution	
-20 to 20mA	-8192 to 8191 counts
0–20 mA	0–8191 counts
4–20 mA	1638–8191 counts

Module General Specifications	
CPU Update Rate	12 channels per scan maximum
Base Power Required	75mA @ 5VDC
External Module Power Supply	21.6–26.4 VDC, 50mA, class 2 (plus 20mA per channel loop)
Operating Temperature	0° to 60°C (32° to 140°F)
Storage Temperature	- 20° to 70°C (- 4° to 158°F)
Accuracy vs. Temperature	±50ppm / °C max. full scale
Relative Humidity	5 to 95% (non-condensing)
Environmental Air	No corrosive gases permitted
Vibration	MIL STD 810C 514.2
Shock	MIL STD 810C 516.2
Noise Immunity	NEMA ICS3-304
Weight	136g

Input Wiring & Dimensions

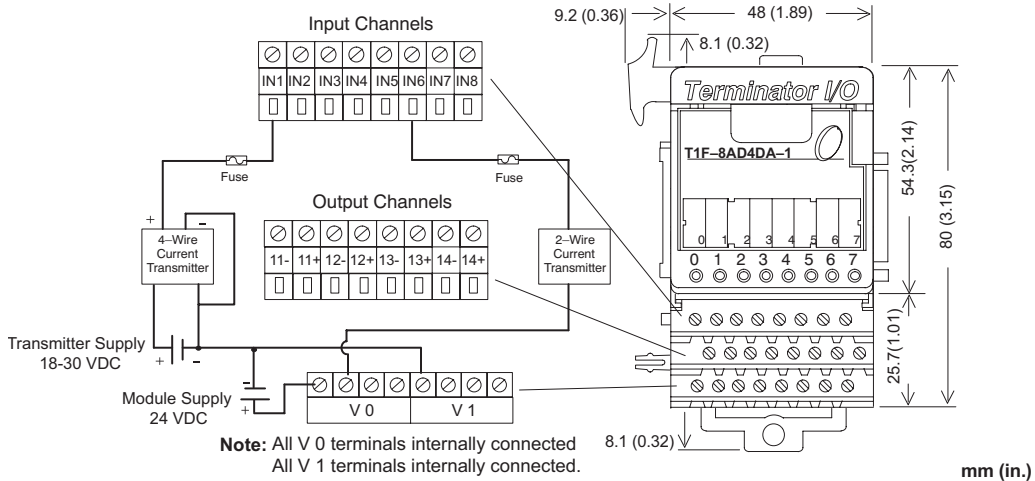

Note: All V 0 terminals internally connected
All V 1 terminals internally connected.

NOTE: Apply the labels that come with the I/O module to the I/O base terminals to properly identify the base terminal points.

NOTES:

1. Shields should be grounded at the signal source.
2. More than one external power supply can be used, provided all the power supply commons are connected.
3. A Series 217, 0.032 A fast-acting fuse is recommended for 4–20 mA current loops.
4. If the power supply common of an external power supply is not connected to the 0V terminal on the module, then the output of the external transmitter must be isolated. To avoid "ground loop" errors, recommended 4–20 mA transmitter types are:
 - For 2 or 3 wire connections: Isolation between the input supply signal and the power supply.
 - For 4 wire connections: Isolation between the input supply signal, the power supply and the 4–20 mA output.

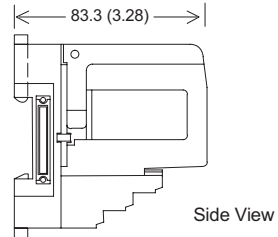

Equivalent Input Circuit

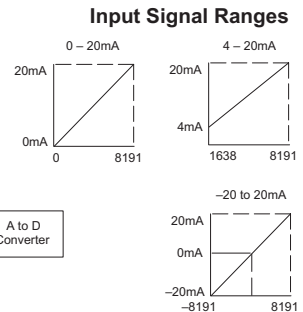
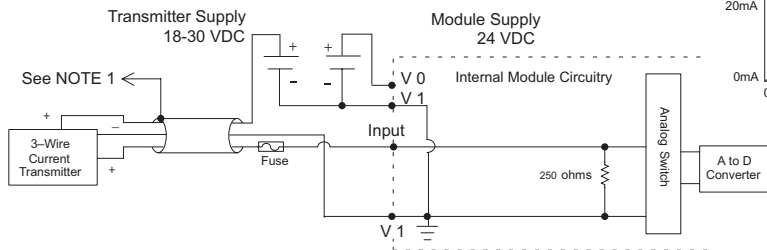

T1F-8AD4DA-1

Output Channel Specifications	
Number of Channels	4, sink/source; individually configured by wiring
Output Points Required	128 discrete pts. or 4 dwords (d (double) word = 32 bit word) Network Interface dependent
Output Range	4–20 mA
Output Type	Single ended, 1 common
Resolution	12 bit (1 in 4096)
Maximum Loop Supply	30VDC
Source Load (ohms) / Loop Power Supply	0–400 Ω / 18–30 V
Sink Load (ohm) / Loop Power Supply	0–600 Ω / 18V, 0–900 Ω / 24V, 0–1200 Ω / 30V
Total Load (Sink plus Source)	600 Ω / 18V, 900 Ω / 24V, 1200 Ω / 30V
Linearity Error (end to end)	± 2 count maximum $\pm 0.050\%$ of full scale maximum
Conversion Settling Time	400 μ s maximum full scale change
Full Scale Calibration Error (Note: source error depends upon the load from source terminal to ground)	SINK: ± 12 counts max. @ any load SOURCE: ± 26 counts max. @ 400 Ω load ± 18 counts max. @ 250 Ω load ± 12 counts max. @ 125 Ω load
Offset Calibration Error	SINK: ± 6 counts max. @ any load SOURCE: ± 10 counts max. @ 400 Ω load ± 8 counts max. @ 250 Ω load ± 6 counts max. @ 125 Ω load
Max. Full Scale Inaccuracy (% of full scale); all errors included	SINK: (Any load) 0.3% @ 25°C (Any load) 0.5% @ 60°C SOURCE: 400 Ω load 0.63% @ 25°C 400 Ω load 0.83% @ 60°C 250 Ω load 0.44% @ 25°C 250 Ω load 0.64% @ 60°C 125 Ω load 0.30% @ 25°C 125 Ω load 0.50% @ 60°C



NOTE: This module requires software setup via the Module Control Byte. Refer to Chapter 4.

Output Wiring & Dimensions

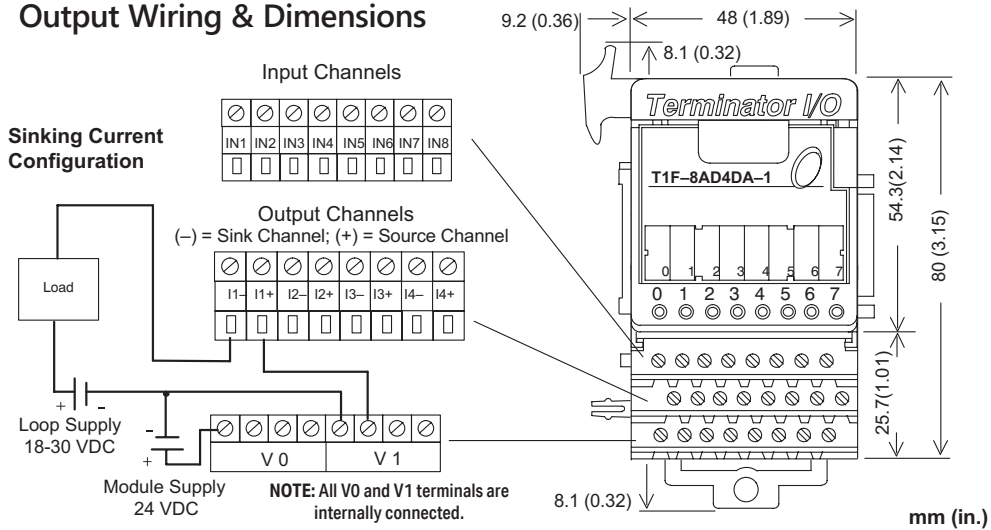

Output Signal Range

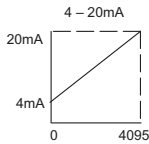

NOTES:

1. Shields should be connected to the 0V terminal of the module or the 0V of the power supply.
2. Unused current outputs should remain open (no connections) for minimum power consumption.

Equivalent Output Circuit

Sourcing Current Configuration

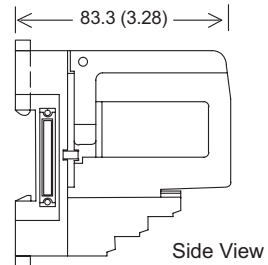
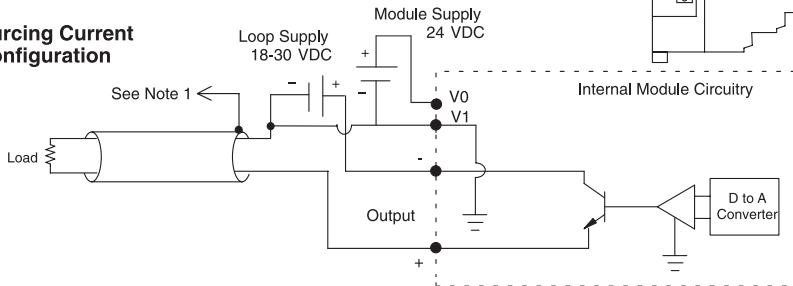

Sinking Current Configuration

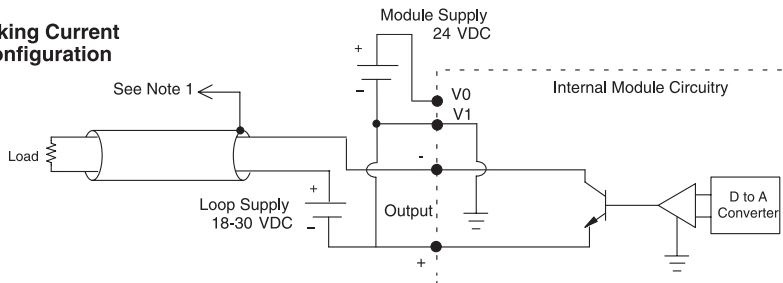

T1F-8AD4DA-2 8-Channel Voltage Analog Input / 4-Channel Voltage Analog Output

Input Channel Specifications	
Number of Channels	8, single ended (1 common)
Input Ranges	0–5 V, 0–10 V, $\pm 5V$, $\pm 10V$
Resolution	14 bit (13 bit plus sign bit)
Frequency Response	-3db @ 500Hz, -20db / decade
Input Resistance	200k Ω min.
Absolute Maximum Ratings	Fault Protected Input, 130V (rms) or 100VDC
Conversion Time	5.5 ms per channel
Linearity Error	± 2 count max.
Input Stability	± 1 count
Calibration Full Scale Error	8 counts max.
Calibration Offset Error	2 counts max.
Max. Full Scale Inaccuracy (% of full scale); all errors included	0.08% @ 25°C 0.26% @ 60°C
Master Update Rate	8 channels per scan maximum
Input Points Required	256 discrete pts. or 8 dwords (d (double) word = 32 bit word) Network Interface dependent
Base Power Required	75mA @ 5VDC
External Module Power Supply	21.6–26.4 VDC, 70mA, class 2
External Transmitter Power Supply	18–30 VDC, 70mA, class 2

Input Range Resolution	
0–5 V	0–4095 counts
0–10 V	0–8191 counts
$\pm 5V$	- 4095 to 4095 counts
$\pm 10V$	- 8192 to 8191 counts



NOTE: Apply the labels that come with the I/O module to the I/O base terminals to properly identify the base terminal points.

Input Wiring & Dimensions

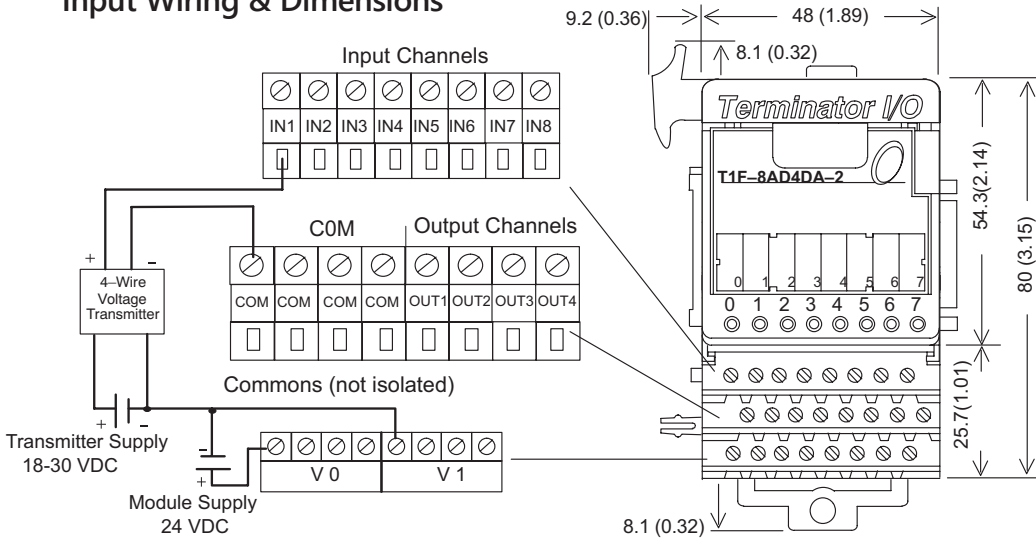

NOTES:

1. V1 terminals are internally connected to Commons.
2. Shields should be grounded at the signal source.
3. Unused inputs should be connected to Common (0VDC).
4. More than one external power supply can be used, provided all the power supply commons are connected.

mm (in.)

Input Signal Ranges

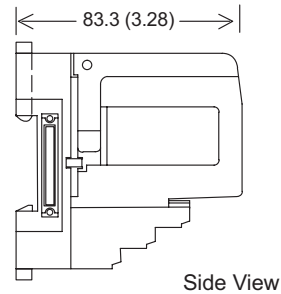
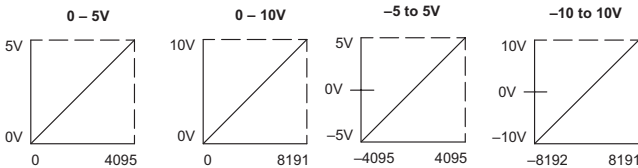

Equivalent Input Circuit

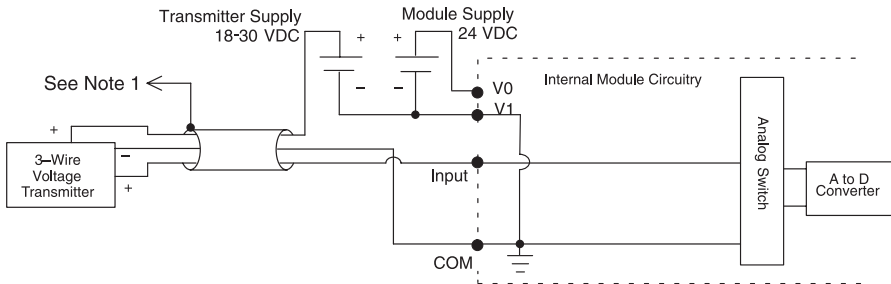

T1F-8AD4DA-2

Output Channel Specifications	
Number of Channels	4
Output Ranges	0–5 V, 0–10 V, $\pm 5V$, $\pm 10V$
Output Type	Single ended, 1 common
Resolution	12 bit (1 in 4096)
Peak Output Voltage	15VDC
Load Impedance	4k Ω minimum
Load Capacitance	0.01 μF maximum
Linearity Error (end to end)	± 2 count maximum $\pm 0.050\%$ of full scale maximum
Conversion Settling Time	300 μs maximum full scale change
Full Scale Calibration Error	± 12 counts maximum
Accuracy vs. Temperature	± 50 ppm/ $^{\circ}C$; full scale calibration change
Offset Calibration Error	10V ranges: ± 5 counts 5V ranges: ± 9 counts
Max. Full Scale Inaccuracy (% of full scale); all errors and temperature drift included	10V ranges: $\pm 0.2\%$ @ 25 $^{\circ}C$ $\pm 0.4\%$ @ 60 $^{\circ}C$ 5V ranges: $\pm 0.3\%$ @ 25 $^{\circ}C$ $\pm 0.5\%$ @ 60 $^{\circ}C$
Master Update Rate	4 channels per scan max.
Output Points Required	128 discrete pts. or 4 Dwords (32-bit words) (Network Interface Dependent)

Module General Specifications	
Operating Temperature	0 $^{\circ}$ to 60 $^{\circ}C$ (32 $^{\circ}$ to 140 $^{\circ}F$)
Storage Temperature	-20 $^{\circ}$ to 70 $^{\circ}C$ (-4 $^{\circ}$ to 158 $^{\circ}F$)
Accuracy vs. Temperature	± 50 ppm / $^{\circ}C$ max. full scale
Relative Humidity	5 to 95% (non-condensing)
Environmental Air	No corrosive gases permitted
Vibration	MIL STD 810C 514.2
Shock	MIL STD 810C 516.2
Noise Immunity	NEMA ICS3-304
Weight	136g

Output Wiring & Dimensions

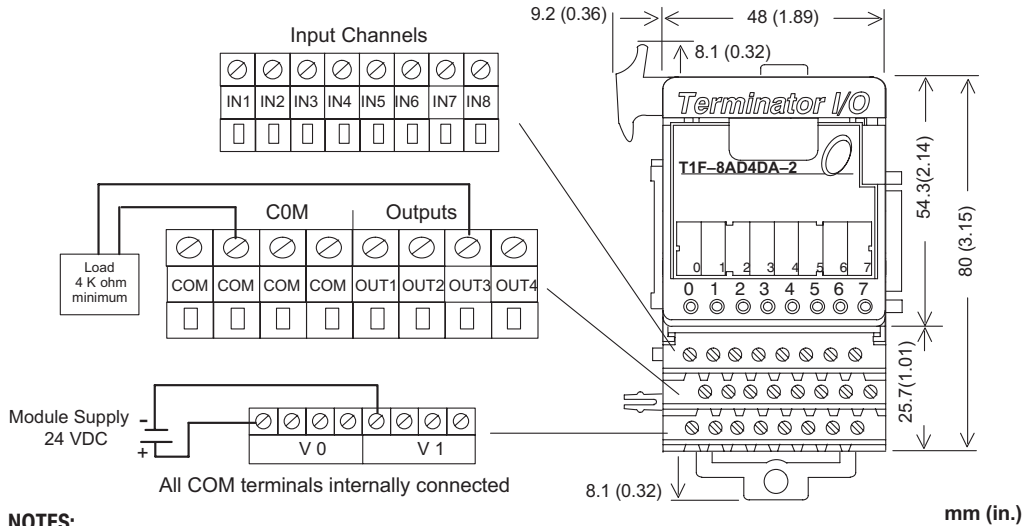

NOTES:

1. V1 terminals are internally connected.
2. Shields should be connected to the 0V terminal of the module at the 0V terminal of the power supply.
3. Unused voltage outputs should remain open (no connections) for minimum power consumption.

Output Range Resolution:

0 – 5V	0 – 4095
0 to 10V	0 – 4095
± 5V	0 – 4095
±10V	0 – 4095

Unipolar Ranges

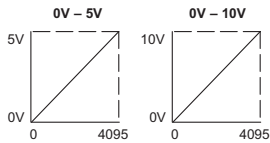

Bipolar Ranges

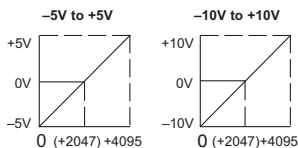

Equivalent Output Circuit

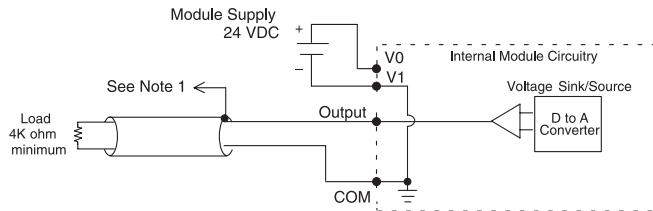

NOTE: The output channels require software setup via the Module Control Byte. Refer to Chapter 4.

T1H-CTRIO Counter I/O Module

Input Specifications	
Input	8 pts. (2 isolated channels / 4 pts. each channel), sink / source, 100kHz maximum; See Input Resources Table for available Input Function options.
Minimum Pulse Width	5 μ s
Input Voltage Range	9–30 VDC
Maximum Voltage	30VDC
Input Voltage Protection	Zener clamped at 33VDC
Rated Input Current	8mA typical, 12mA maximum
Minimum ON Voltage	9.0 VDC
Maximum OFF Voltage	2.0 VDC
Minimum ON Current	5.0 mA @ 9.0 VDC
Maximum OFF Current	2.0 mA
OFF to ON Response	< 3.0 μ s
ON to OFF Response	< 3.0 μ s

Output Specifications	
Outputs	4 pts., independently isolated, sink / source (FET Outputs); See Output Resources Table for available Output Function options.
Voltage Range	5–36 VDC
Maximum Voltage	36VDC
Output Clamp Voltage	60VDC
Maximum Load Current	1.0 A
Maximum Leakage Current	100 μ A
Inrush Current	5.0 A for 20ms
OFF to ON Response	< 3.0 μ s
ON to OFF Response	< 3.0 μ s
ON State Voltage Drop	< 0.3 V
External Power Supply	For loop power only, is not required for internal module function.
Overcurrent Protection	15A maximum
Base Power Required	400mA @ 5VDC
Thermal Shutdown	T _{junction} = 150°C
Overtemperature Reset	T _{junction} = 130°C
Duty Cycle Range	1% to 99% in 1% increments
Configurable Presets	a) Each output can be assigned one preset, or b) Each output can be assigned one table of presets, one table can contain max. 128 presets, max. predefined tables = 255
a) single	
b) multiple	

General Specifications	
Module Type	Intelligent
Modules Per Base	Limited only by power consumption
I/O Points Used	None, I/O map directly in PLC V-memory or PC control access
Field Wiring Connector	Standard removable terminal block
Internal Power Consumption	400mA Max at +5V from Base Power Supply, Maximum of 6 Watts (All I/O in ON State at Max Voltage/Current)
Operating Environment	32°F to 140°F (0°C to 60°C), Humidity (non-condensing) 5% to 95%
Isolation	2500V I/O to Logic, 1000V among Input Channels and All Outputs

Wiring & Dimensions

Input / Output Channels															
1A	1B	1C	1D	Y0	Y0	Y1	Y1	2A	2B	2C	2D	Y2	Y2	Y3	Y3
□	□	□	□	□	□	□	□	□	□	□	□	□	□	□	□

Channel Commons															
1M	1M	1M	1M	C0	C0	C1	C1	2M	2M	2M	2M	C2	C2	C3	C3
□	□	□	□	□	□	□	□	□	□	□	□	□	□	□	□

User Bus Terminals (no internal connection to CTRLIO)															
□	□	□	□	□	□	□	□	□	□	□	□	□	□	□	□
USER BUS 1							USER BUS 2								
□	□	□	□	□	□	□	□	□	□	□	□	□	□	□	□

NOTE: Apply the labels that come with the I/O module to the I/O base terminals to properly identify the base terminal points.

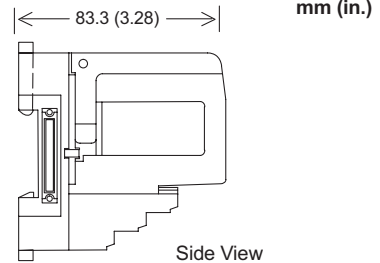
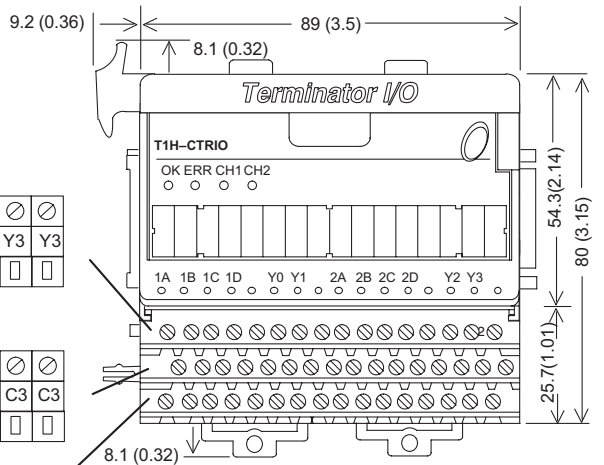

LED Indicators

LED Diagnostic Definitions		
OK	ERR	Description
ON	OFF	All is well - Run Mode
ON	ON	Hardware Failure
Blinking	Blinking	Boot Mode - Use for Field OS Upgrades
Blinking	OFF	Program Mode
OFF	Blinking	Module Self - diagnostic Failure
OFF	ON	Module Error due to Watchdog Timeout
OFF	OFF	No Power to Module

LED Descriptions	
OK	Module OK
ERR	User Program Error
CH1	Channel 1 Status
CH2	Channel 2 Status
1A-1D	Channel 1 A-D Status
2A-2D	Channel 2 A-D Status
Y0-Y3	Output Status

More LED Diagnostics Definitions	
CH1	Blinks when Channel 1 Function 1 is counting or timing.
CH2	Blinks when Channel 2 Function 1 is counting or timing.
Y0-Y3	Follows actual output state; ON = output is passing current.

T1H-CTRIO Input Wiring Diagrams

TTL Input Wiring Example

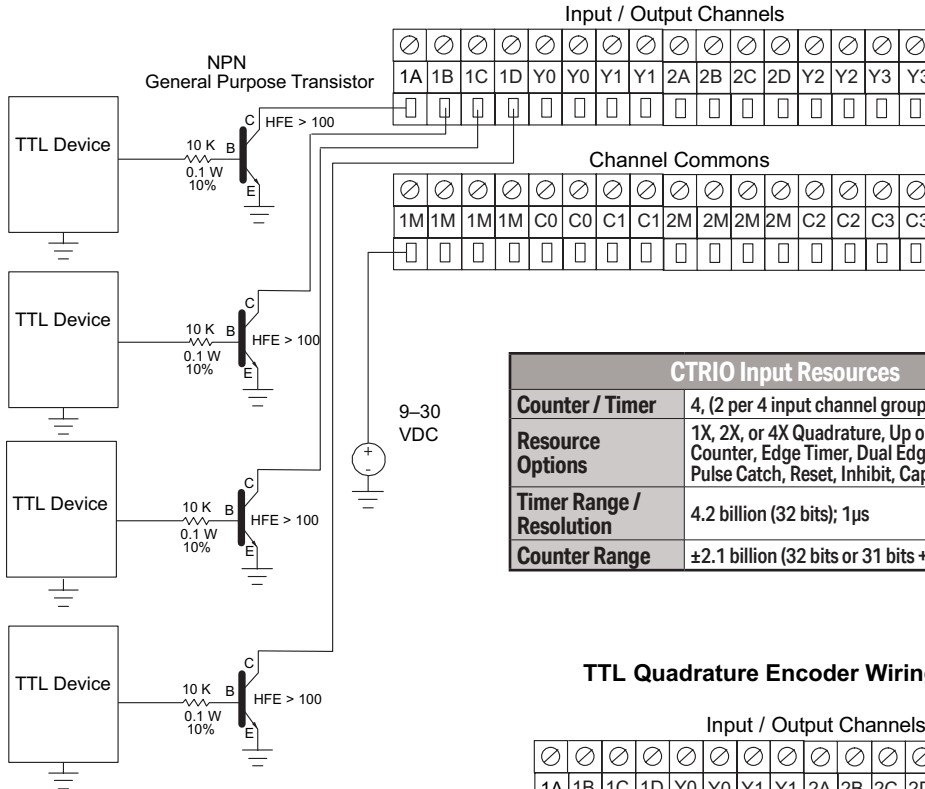

CTRIO Input Resources	
Counter / Timer	4, (2 per 4 input channel group)
Resource Options	1X, 2X, or 4X Quadrature, Up or Down Counter, Edge Timer, Dual Edge Timer, Pulse Catch, Reset, Inhibit, Capture
Timer Range / Resolution	4.2 billion (32 bits); 1µs
Counter Range	±2.1 billion (32 bits or 31 bits + sign bit)

TTL Quadrature Encoder Wiring Example

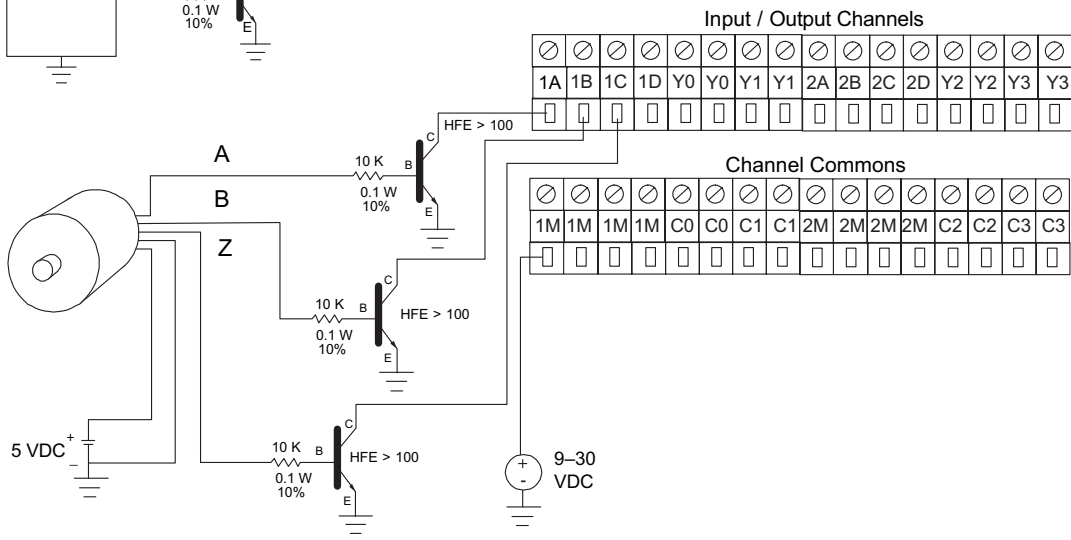

T1H-CTRIO Input Wiring Diagrams

Quadrature Encoder Wiring Example

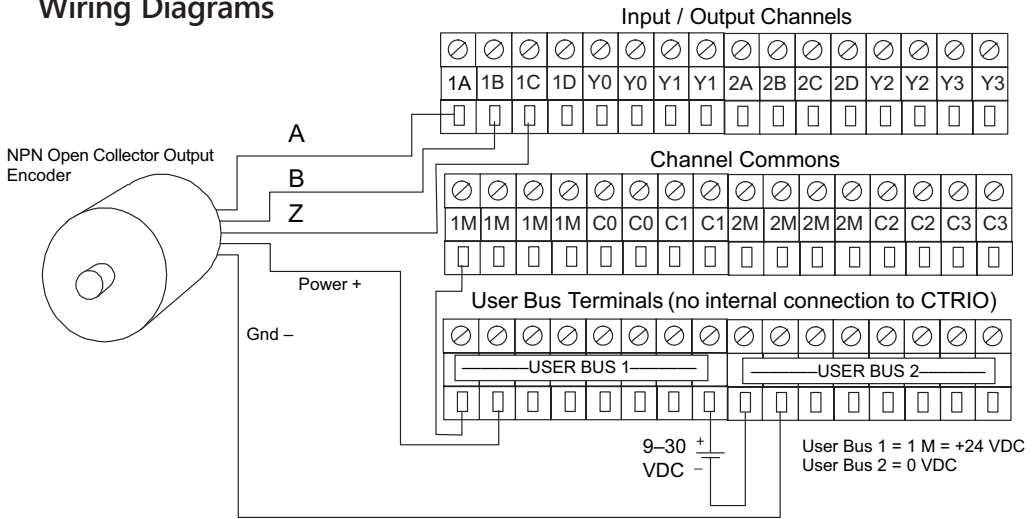

Input Wiring Example

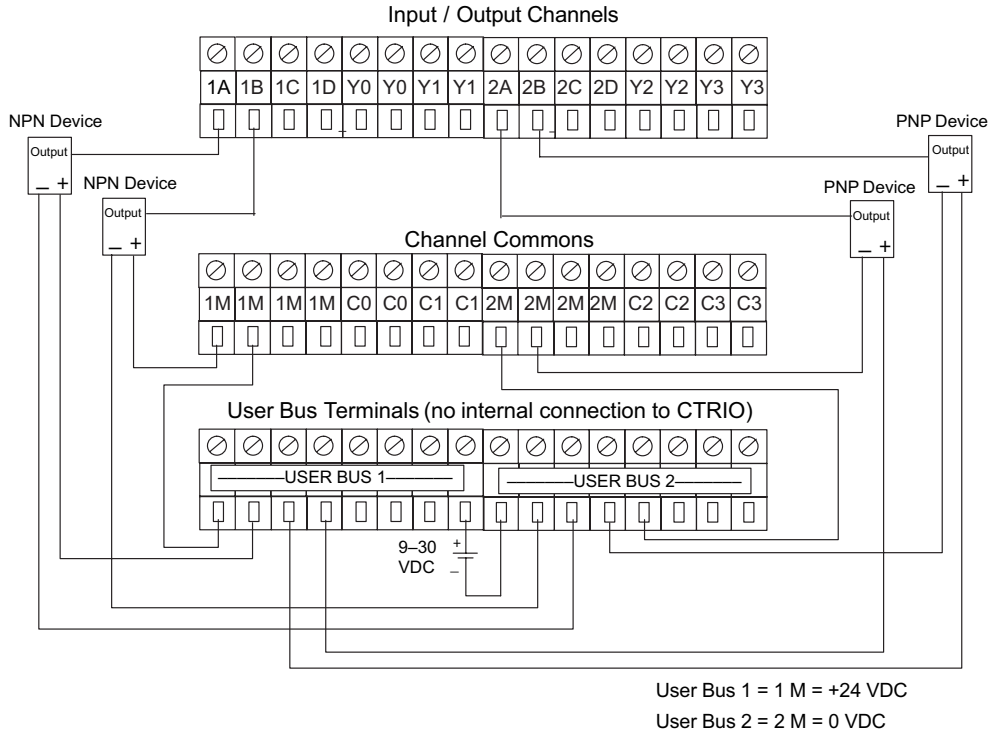

T1H-CTRIO Output Wiring Diagrams

The module has 4 optically isolated output points (Pts. Y0–Y3 with isolated commons C0–C3, respectively). The outputs must be wired so positive current flows into Cn terminal and then out of the Yn terminal.

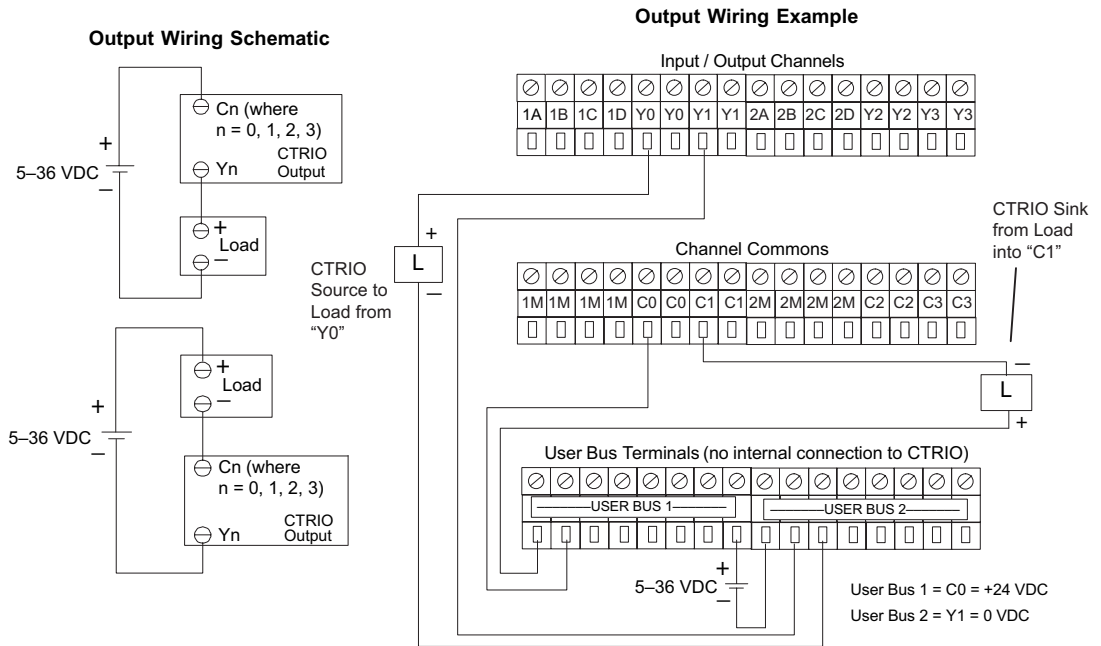

T1H-CTRIO Output Wiring Diagrams

The stepper wiring example assumes the Step Amplifier interface to be opto-coupler LEDs (common anodes at the “Opto Power” terminal) with internal current limiting resistors. This is a standard method, but you must consult your stepper amplifier documentation to ensure that this method is applicable.

Stepper / Servo Drive Wiring Example

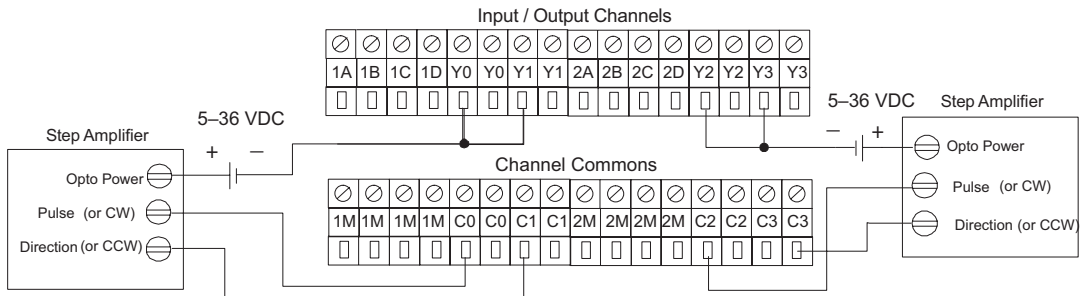

CTRIO Output Resources	
Pulse outputs / Discrete outputs	Pulse outputs: 2 Channels (2 outputs per channel) Discrete outputs: 4 pts.
Resource Options	Pulse outputs: pulse / direction or CW / CCW. Profiles: Trapezoid, S-Curve, Symmetrical S-Curve, Dynamic Positioning, Dynamic Velocity, Home Search, Velocity Mode, Run to Limit Mode, and Run to Position Mode. Discrete Outputs: 4 configurable for set, reset, pulse on, pulse off, toggle, and reset count function (assigned to respond to Timer / Counter functions). Raw Mode: Direct access to output from user program.
Target Position Range	±2.1 billion (32 bits or 31 bits + sign bit)

T1K-08B(-1) I/O Module Base

Specifications		
Specification	T1K-08B	T1K-08B-1
Terminal Type	Screw type	Spring clamp type
Recommended Torque	1.77–3.54 lb-in (0.2–0.4 N·m)	N/A
Recommended Screwdriver Blade Size	0.02 in. X 0.125 in. (0.5 mm X 3.0 mm)	Push in on clamp using screwdriver blade size: 0.016 X 0.79 in. to 0.032 X 0.16 in. (0.4 mm X 2mm to 0.8 mm X 4mm)
Wire Gauge Size	Solid conductor: 25–12 AWG Stranded conductor: 26–12 AWG*	Solid conductor: 25–14 AWG Stranded conductor: 26–14 AWG*
Weight	135g	125g

*Twist conductors before inserting into gate.

T1K-16B(-1) I/O Module Base

Specifications		
Specification	T1K-16B	T1K-16B-1
Terminal Type	Screw type	Spring clamp type
Recommended Torque	1.77–3.54 lb-in (0.2–0.4 N·m)	N/A
Recommended Screwdriver Blade Size	0.02 in. X 0.125 in. (0.5 mm X 3.0 mm)	Push in on clamp using screwdriver blade size: 0.016 X 0.79 in. to 0.032 X 0.16 in. (0.4 mm X 2mm to 0.8 mm X 4mm)
Wire Gauge Size	Solid conductor: 25–12 AWG Stranded conductor: 26–12 AWG*	Solid conductor: 25–14 AWG Stranded conductor: 26–14 AWG*
Weight	220g	210g

*Twist conductors before inserting into gate.

Environmental Specifications	
Ambient Operating Temperature	32°F to 131°F (0°C to 55°C)
Storage Temperature	-4°F to 158°F (-20°C to 70°C)
Ambient Humidity	5% to 95% (Non-condensing)
Atmosphere	No corrosive gases. The level of environmental pollution = 2 (UL 840).
Vibration Resistance	MIL STD 810C. Method 514.2
Shock Resistance	MIL STD 810C. Method 516.2
Voltage Withstand	1500VAC, 1 minute
Insulation Resistance	500VDC, 10MΩ
Noise Immunity	NEMA ICS3-304 Impulse Noise 1μs, 1000V FCC class A RFI (144MHz, 430MHz 10W, 10cm)
Agency Approvals	UL, CE, FCC class A

Dimensions

T1K-08B, T1K-08B-1

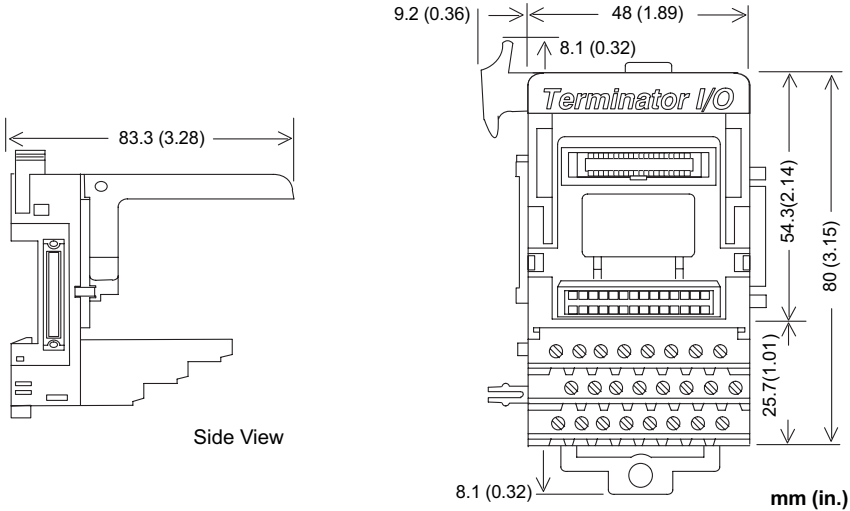

T1K-16B, T1K-16B-1

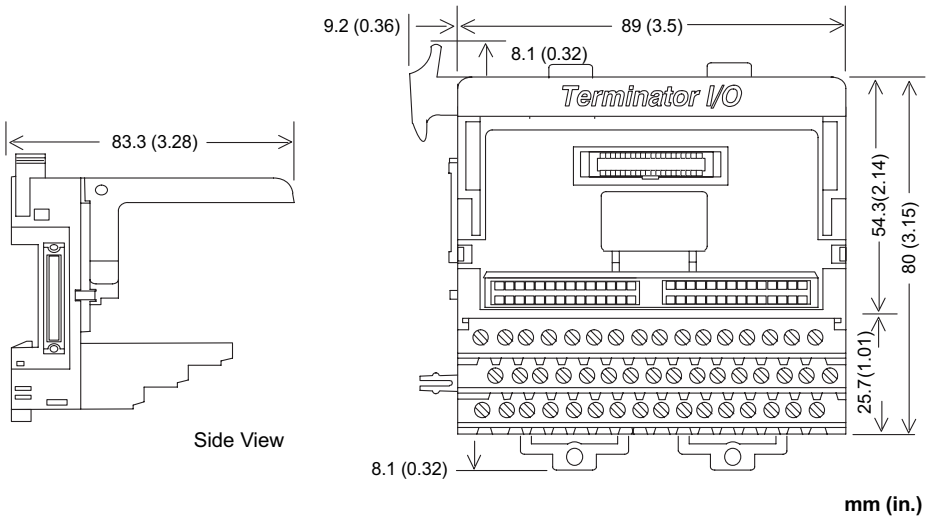

T1K-10CBL, T1K-10CBL-1 Expansion Cable

Specifications

Specifications			
Specification		T1K-10CBL	T1K-10CBL-1
Cable Length		100cm (3.28 ft.)	
Cable Diameter		8.5 mm	
Shielding		None	
Temperature Range		-25°C to 80°C (-13°F to 176°F)	
Jacket Material		PVC	
Auxiliary 24VDC Cable	Cable Diameter	N/A	2 cables used: 1.42 mm each
	Insulation Voltage	N/A	2000VAC / 1 minute

Dimensions

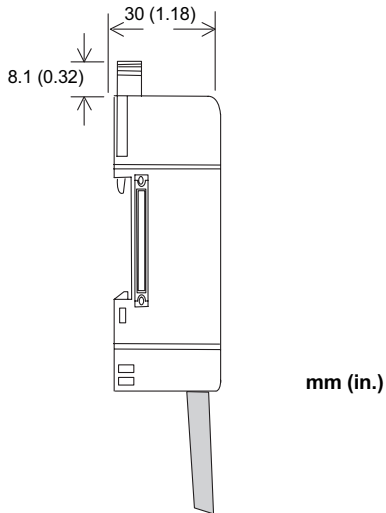
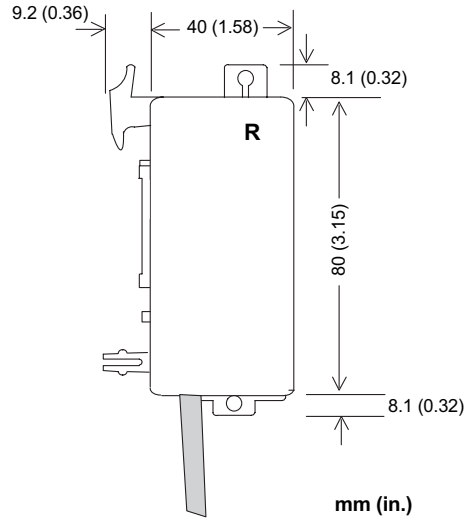
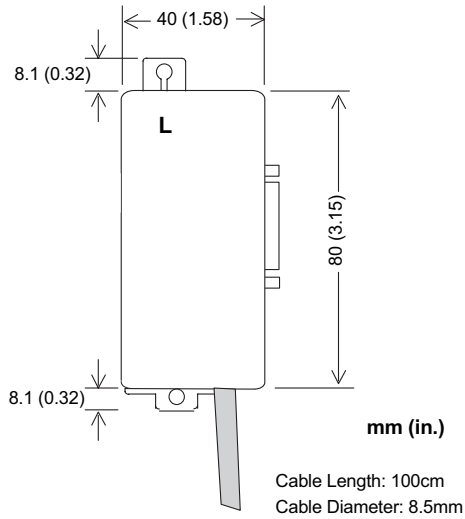

T1K-5CBL-LL(-1) Expansion Cable

Specifications			
Specification		T1K-05CBL-LL	T1K-05CBL-1-LL-1
Cable Description		Left-to-left Side Expansion Cable	
Cable Length		50cm (1.64 ft.)	
Cable Diameter		8.5 mm	
Shielding		None	
Temperature Range		-25°C to 80°C (-13°F to 176°F)	
Jacket Material		PVC	
Auxiliary 24VDC Cable	Cable Diameter	N/A	Two 1.42 mm cables used in a 6mm sheath
	Insulation Voltage	N/A	2000VAC / 1 minute

T1K-5CBL-RR(-1) Expansion Cable

Specifications			
Specification		T1K-05CBL-RR	T1K-05CBL-1-RR-1
Cable Description		Right-to-right Side Expansion Cable	
Cable Length		50cm (1.64 ft.)	
Cable Diameter		8.5 mm	
Shielding		None	
Temperature Range		-25°C to 80°C (-13°F to 176°F)	
Jacket Material		PVC	
Auxiliary 24VDC Cable	Cable Diameter	N/A	Two 1.42 mm cables used in a 6mm sheath
	Insulation Voltage	N/A	2000VAC / 1 minute



NOTE: Please refer to Chapter 2 for application examples using the different types of expansion cables that are available.

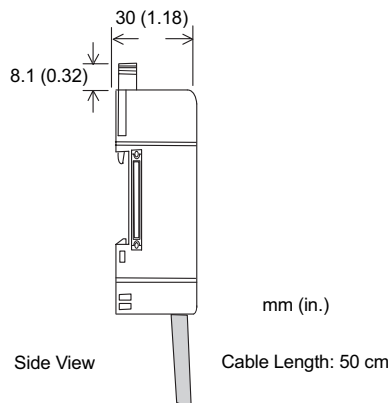

Dimensions

T1K-05CBL-LL(-1)

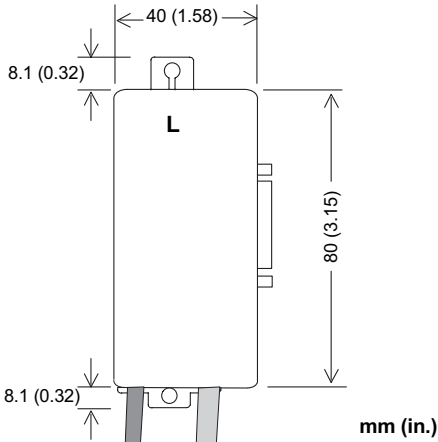

T1K-05CBL-LL-1 has 24 VDC cable attached here

Cable Length: 50 cm

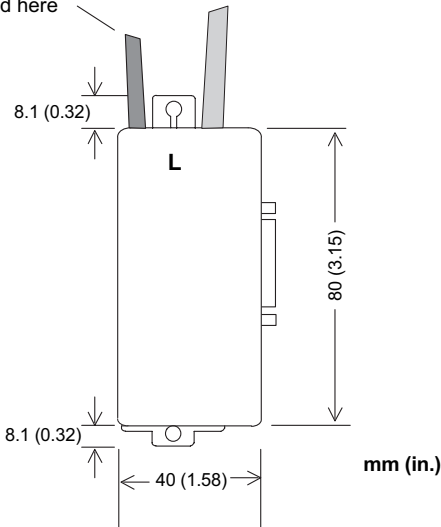

T1K-05CBL-RR(-1)

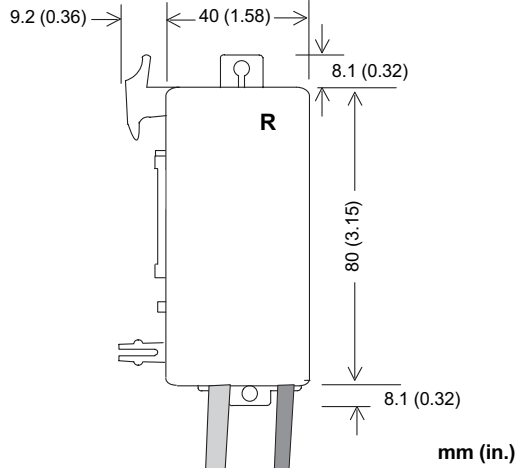

Cable Length: 50 cm

T1K-05CBL-RR-1 has 24 VDC cable attached here

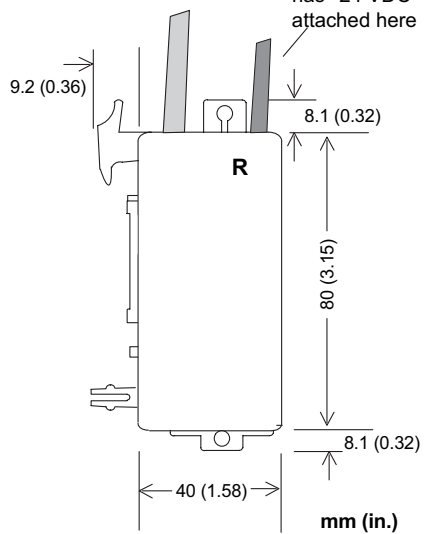

Cable Connection Examples

This is an example using the T1K-05CBL-RR (T1K-05CBL-RR-1) cable. It is always connected from the right side to the right side.



NOTE: Do not put a power supply (P/S) on the expansion row in this example.

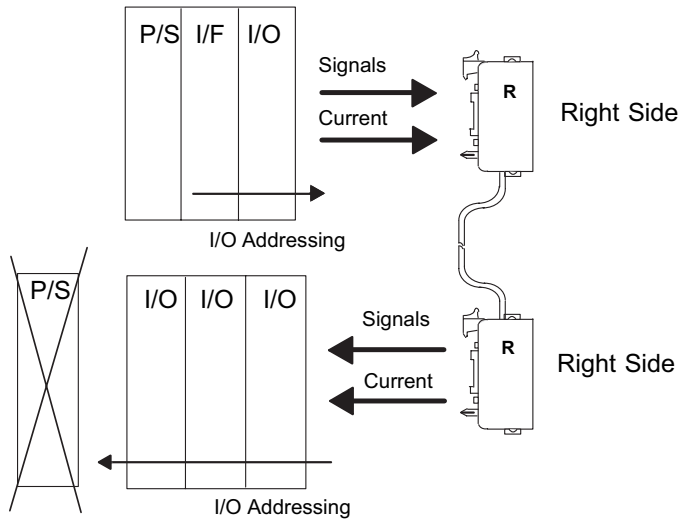

Chapter 3: I/O Wiring and Specifications

When another expansion row is added to the example on the left, a T1K-05CBL-LL (T1K-05CBL-LL-1) cable is used. It is always connected from the left side to the left side, but it is never used as the first cable.

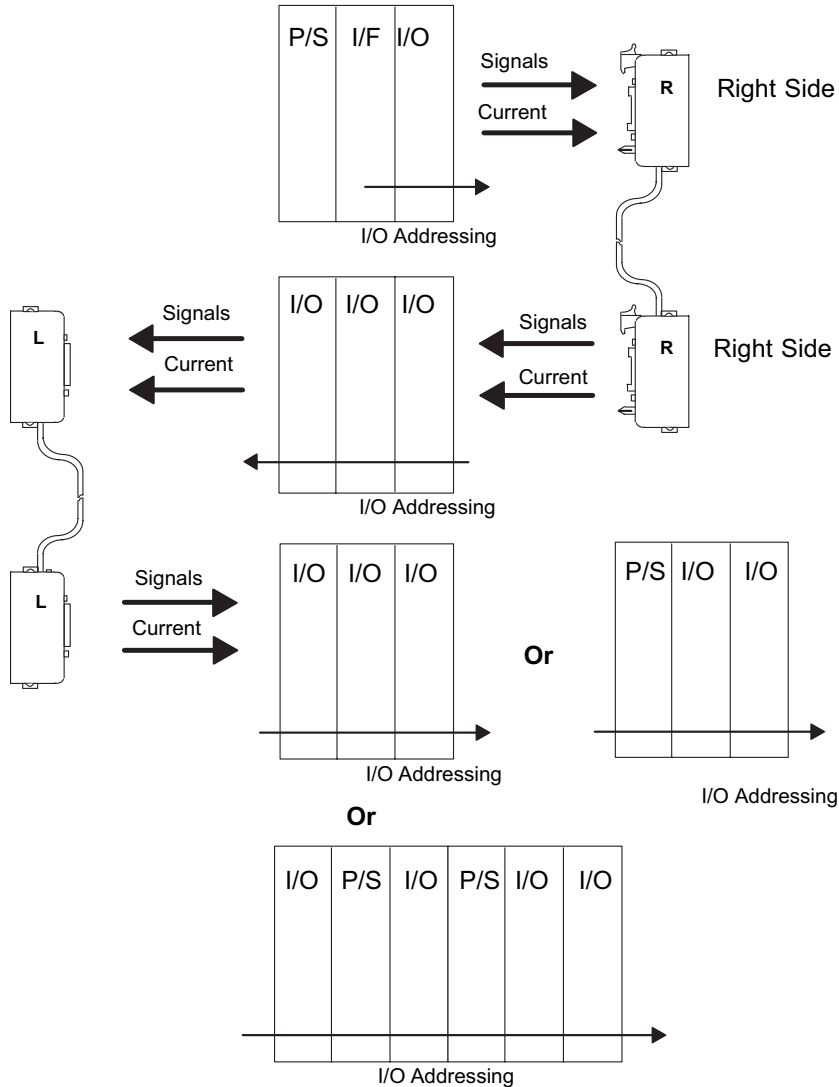

NOTE: Another P/S can be put on the expansion row that is connected through the T1K-05CBL-LL cable.

In this example, a T1K-10CBL cable is used to connect the local base I/O to an expansion row that has a power supply (P/S) installed in the first position on the row. The next expansion row, without a P/S, is connected using a T1K-05CBL-RR-1 cable.

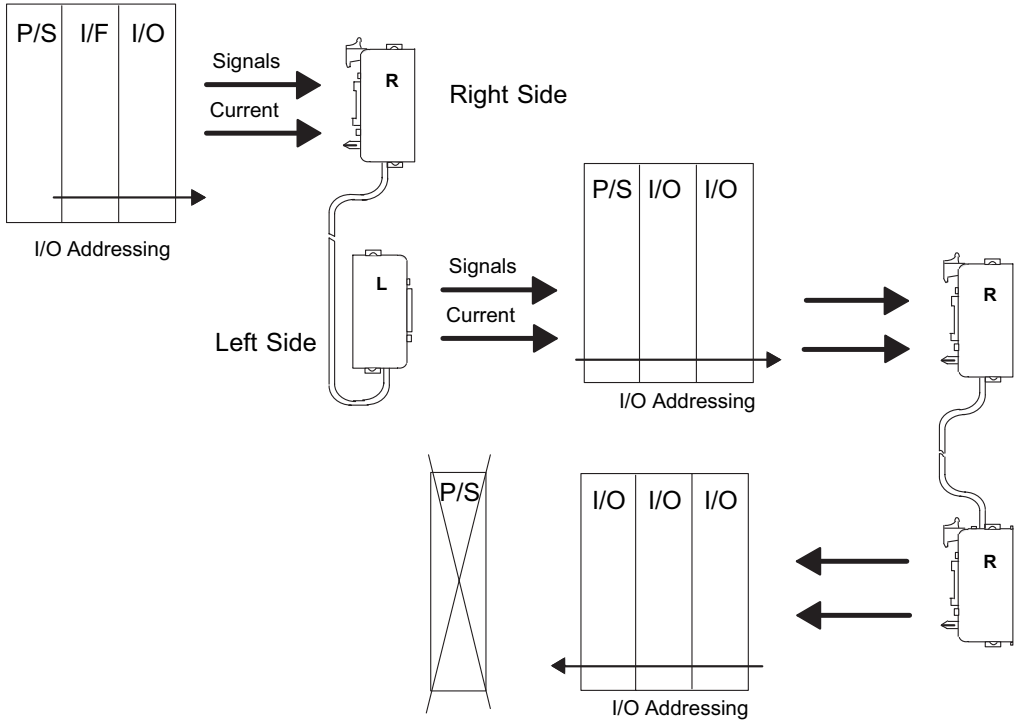

NOTE: Do not put a power supply (P/S) on the last expansion row in this example.

I/O MEMORY MAP AND ANALOG MODULE RESOLUTION



CHAPTER 4

In This Chapter...

Master / Slave Communications.....	4-2
Terminator I/O Backplane Communications	4-2
Discrete Input Module Memory Map	4-3
Discrete Output Module Memory Map	4-4
8-Channel Analog Input Module Memory Map.....	4-5
16-Channel Analog Input Module (T1F-16AD-x, T1F-16RTD, T1F-16TMST (Retired) and T1F-14THM)	4-7
16-Channel Analog Input Module Memory Map	4-8
Analog Input Module Resolution	4-10
T1F-08DA-x, Analog Output Module Memory Map	4-12
T1F-8AD4DA-x, Analog Output Module Memory Map	4-17
Analog Output Module Control Byte.....	4-21
Analog Output Module Resolution.....	4-25

Master / Slave Communications

The base controller (slave) communicates with the master by sending Input Data and receiving Output Data. The base controller *reads* Inputs from I/O Modules and *writes* Outputs to I/O Modules.

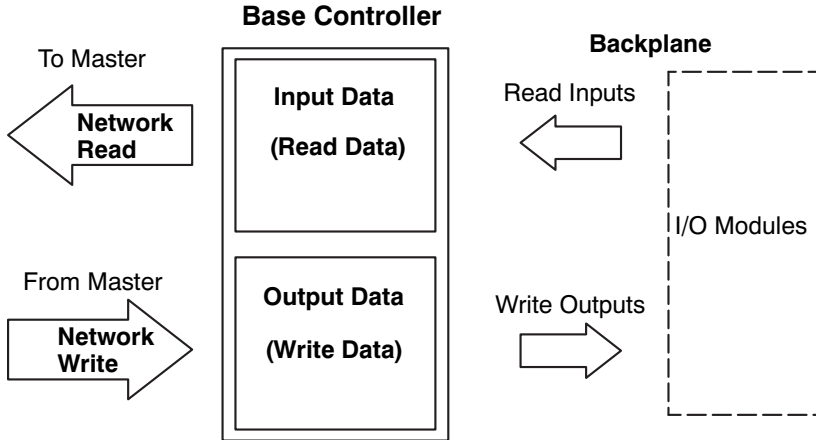

Terminator I/O Backplane Communications

The base controller communicates with its I/O modules over the backplane. The I/O is mapped in consecutive order as shown

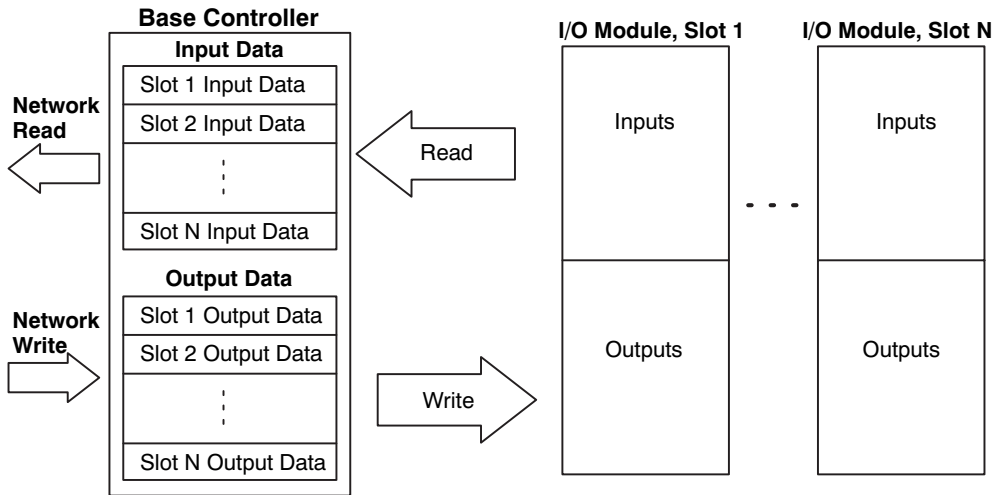

Discrete Input Module Memory Map

8-Point Discrete Input Modules (T1K-08NA-1 and T1K-08ND3)

Image Table Mapping

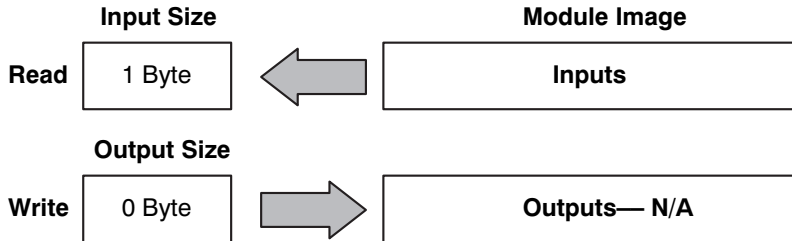

Memory Map of 8-Point Discrete Input Modules									
Decimal Bit	07	06	05	04	03	02	01	00	Size
Octal Bit	07	06	05	04	03	02	01	00	
	X7	X6	X5	X4	X3	X2	X1	X0	Read Byte 1
Not Used									Write Byte 1

16-Point Discrete Input Modules (T1K-16NA-1 and T1K-16ND3)

Image Table Mapping

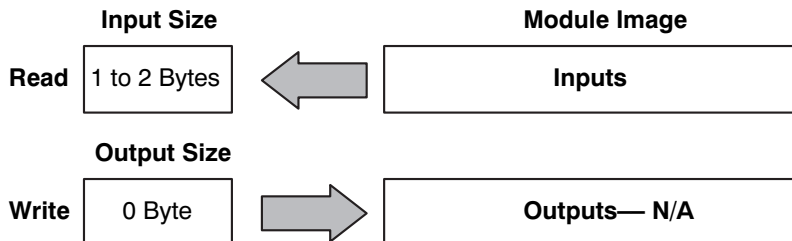

Memory Map of 16-Point Discrete Input Modules										
Decimal Bit	07	06	05	04	03	02	01	00	Size	
Octal Bit	07	06	05	04	03	02	01	00		
	X7	X6	X5	X4	X3	X2	X1	X0	Read Byte 1	
	X17	X16	X15	X14	X13	X12	X11	X10	Read Byte 2	
Not Used									Write Byte 1	

Discrete Output Module Memory Map

8-Point Discrete Output Modules (T1K-08TA(S), T1K-08TD1, T1K-08TD2-1, T1K-08TR(S) and T1H-08TDS Image Table Mapping

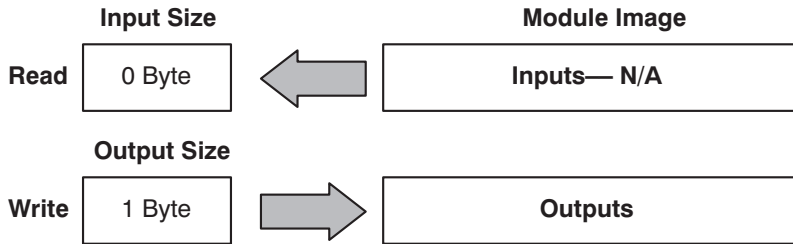

Memory Map of 8-Point Discrete Output Modules									
Decimal Bit	07	06	05	04	03	02	01	00	Size
Octal Bit	07	06	05	04	03	02	01	00	
Not Used									Read Byte 1
	Y7	Y6	Y5	Y4	Y3	Y2	Y1	Y0	Write Byte 1

16-Point Discrete Output Modules (T1K-16TA, T1K-16TD1, T1K-16TD2-1 and T1K-16TR)

Image Table Mapping

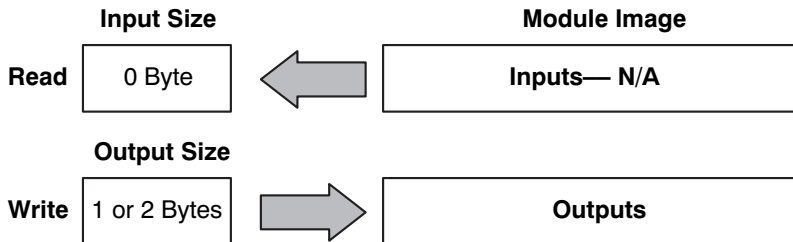

Memory Map of 16-Point Discrete Output Modules										
Decimal Bit	07	06	05	04	03	02	01	00	Size	
Octal Bit	07	06	05	04	03	02	01	00		
Not Used									Read Byte 1	
	Y7	Y6	Y5	Y4	Y3	Y2	Y1	Y0	Write Byte 1	
	Y17	Y16	Y15	Y14	Y13	Y12	Y11	Y10	Write Byte 2	

8-Channel Analog Input Module Memory Map

8-Channel Analog Input Module (T1F-08AD-x)

Image Table Mapping

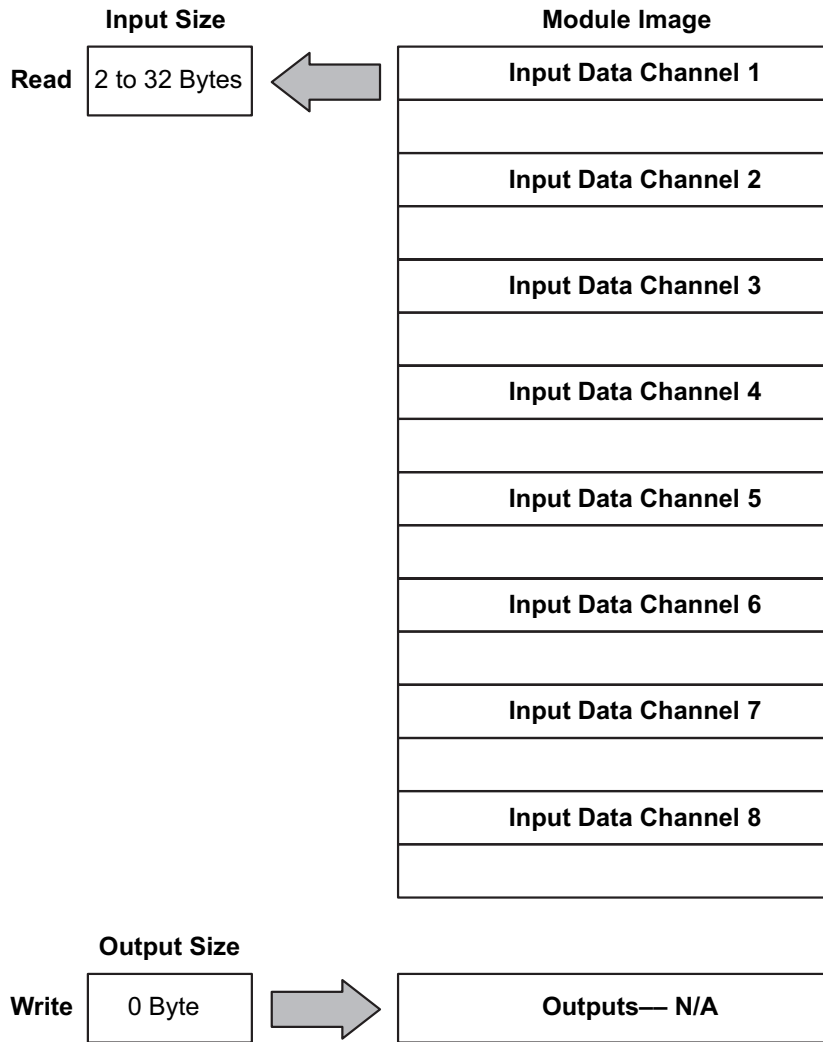

Analog Input Module Memory Map, cont'd

Memory Map of 8-Channel Analog Input Module										
Decimal Bit	07	06	05	04	03	02	01	00	Size	
Octal Bit	07	06	05	04	03	02	01	00		
									Analog Value Channel 1	Read Byte 1
									Analog Value Channel 1	Read Byte 2
									Not Used	Byte 3
									Reserved for future use	Byte 4
									Analog Value Channel 2	Read Byte 5
									Analog Value Channel 2	Read Byte 6
									Not Used	Byte 7
									Reserved for future use	Byte 8
									Analog Value Channel 3	Read Byte 9
									Analog Value Channel 3	Read Byte 10
									Not Used	Byte 11
									Reserved for future use	Byte 12
									Analog Value Channel 4	Read Byte 13
									Analog Value Channel 4	Read Byte 14
									Not Used	Byte 15
									Reserved for future use	Byte 16
									Analog Value Channel 5	Read Byte 17
									Analog Value Channel 5	Read Byte 18
									Not Used	Byte 19
									Reserved for future use	Byte 20
									Analog Value Channel 6	Read Byte 21
									Analog Value Channel 6	Read Byte 22
									Not Used	Byte 23
									Reserved for future use	Byte 24
									Analog Value Channel 7	Read Byte 25
									Analog Value Channel 7	Read Byte 26
									Not Used	Byte 27
									Reserved for future use	Byte 28
									Analog Value Channel 8	Read Byte 29
									Analog Value Channel 8	Read Byte 30
									Not Used	Byte 31
									Reserved for future use	Byte 32
									Not Used	Write Byte 1

16-Channel Analog Input Module Memory Map

Memory Map of 16-Channel Analog Input Module										
Decimal Bit	07	06	05	04	03	02	01	00	Size	
Octal Bit	07	06	05	04	03	02	01	00		
									Analog Value Channel 1	Read Byte 1
									Analog Value Channel 1	Read Byte 2
									Not Used	Byte 3
									Reserved for future use	Byte 4
									Analog Value Channel 2	Read Byte 5
									Analog Value Channel 2	Read Byte 6
									Not Used	Byte 7
									Reserved for future use	Byte 8
									Analog Value Channel 3	Read Byte 9
									Analog Value Channel 3	Read Byte 10
									Not Used	Byte 11
									Reserved for future use	Byte 12
									Analog Value Channel 4	Read Byte 13
									Analog Value Channel 4	Read Byte 14
									Not Used	Byte 15
									Reserved for future use	Byte 16
									Analog Value Channel 5	Read Byte 17
									Analog Value Channel 5	Read Byte 18
									Not Used	Byte 19
									Reserved for future use	Byte 20
									Analog Value Channel 6	Read Byte 21
									Analog Value Channel 6	Read Byte 22
									Not Used	Byte 23
									Reserved for future use	Byte 24
									Analog Value Channel 7	Read Byte 25
									Analog Value Channel 7	Read Byte 26
									Not Used	Byte 27
									Reserved for future use	Byte 28
									Analog Value Channel 8	Read Byte 29
									Analog Value Channel 8	Read Byte 30
									Not Used	Byte 31
									Reserved for future use	Byte 32

(Memory Map table continued on following page.)

16-Channel Analog Input Module Memory Map, cont'd

Memory Map of 16-Channel Analog Input Module										
Decimal Bit	07	06	05	04	03	02	01	00	Size	
Octal Bit	07	06	05	04	03	02	01	00		
									Analog Value Channel 9	Read Byte 33
									Analog Value Channel 9	Read Byte 34
									Not Used	Byte 35
									Reserved for future use	Byte 36
									Analog Value Channel 10	Read Byte 37
									Analog Value Channel 10	Read Byte 38
									Not Used	Byte 39
									Reserved for future use	Byte 40
									Analog Value Channel 11	Read Byte 41
									Analog Value Channel 11	Read Byte 42
									Not Used	Byte 43
									Reserved for future use	Byte 44
									Analog Value Channel 12	Read Byte 45
									Analog Value Channel 12	Read Byte 46
									Not Used	Byte 47
									Reserved for future use	Byte 48
									Analog Value Channel 13	Read Byte 49
									Analog Value Channel 13	Read Byte 50
									Not Used	Byte 51
									Reserved for future use	Byte 52
									Analog Value Channel 14	Read Byte 53
									Analog Value Channel 14	Read Byte 54
									Not Used	Byte 55
									Reserved for future use	Byte 56
									Analog Value Channel 15	Read Byte 57
									Analog Value Channel 15	Read Byte 58
									Not Used	Byte 59
									Reserved for future use	Byte 60
									Analog Value Channel 16	Read Byte 61
									Analog Value Channel 16	Read Byte 62
									Not Used	Byte 63
									Reserved for future use	Byte 64
									Not Used	Write Byte 1

Analog Input Module Resolution

Input Module Resolution

Since the module has 13-bit resolution, the analog signal is converted into 8192 counts ranging from 0-8191 (2^{13}). For example, with a 0 to 10V scale, a 0V signal would be 0, and a 10 V signal would be 8191. This is equivalent to a binary value of 0000 0000 0000 to 0001 1111 1111, or 000 to 1FFF hexadecimal. The following diagram shows how this relates to each signal range.

Current Input Module Resolution

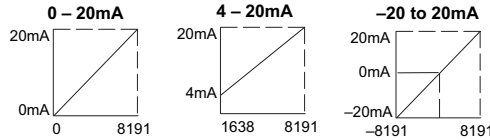

Voltage Input Module Resolution

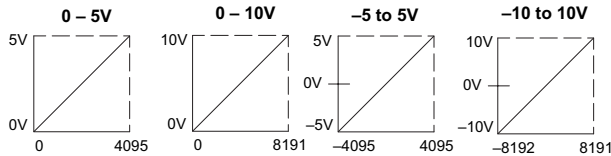

NOTE: The 0-5 V and -5 to 5V range resolution is 4095, however, if the range is exceeded to 5.5 V, for example, the digital input reading will reflect the correct value up to 10 V (8191). The 4-20 mA range is 1638 to 8191. If the input current signal level falls below 4mA, the correct value will be read down to 0mA.

Channel Data Bits

The first thirteen bits represent the analog data in binary format. The Fourteenth bit is the data sign bit.

Bit	Value	Bit	Value
0	1	7	128
1	2	8	256
2	4	9	512
3	8	10	1024
4	16	11	2048
5	32	12	4096
6	64	13	Sign Bit

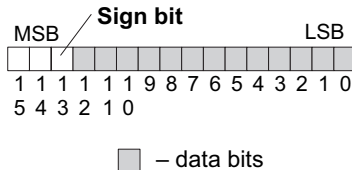

NOTE: Each analog channel uses 4 bytes. The first and second byte contain the analog data. The third and fourth byte are not used at this time.

Each count can also be expressed in terms of the signal level by using the equation shown. The following table shows the smallest signal level that will result in a change in the data value for each signal range.

$$\text{Smallest Detectable Change} = \frac{H - L}{\text{Resolution}}$$

H = high limit of the signal range

L = low limit of the signal range

Range	Signal Span (H - L)	Divide By	Smallest Detectable Change
± 10V	20V	16383	1.22 mV
± 5V	10V	8191	1.22 mV
0 to 5V	5V	4095	1.22 mV
0 to 10V	10V	8191	1.22 mV
0 to 20mA	20mA	8191	2.44 µA
4 to 20mA	16mA	(8191-1638)	2.44 µA
± 20mA	40mA	16383	2.44 µA

Analog and Digital Value Conversions

Sometimes it is helpful to be able to quickly convert between the signal levels and the digital values. This is especially useful during machine startup or troubleshooting. The following table provides formulas to make this conversion easier.

Range	If you know the digital value...	If you know the analog value...
-10V to +10V	$A = 20D / 8191 - 10$	$D = 8191 / 20 (A + 10)$
-5V to +5V	$A = 10D / 4095 - 5$	$D = 4095 / 10 (A + 5)$
0 to 5V	$A = 5D / 4095$	$D = 4095 / 5 (A)$
0 to 10V	$A = 10D / 8191$	$D = 8191 / 10 (A)$
0 to 20mA	$A = 20D / 8191$	$D = 4095 / 4 (A)$
4 to 20mA	$A = 16D / 6553$	$D = 6553 / 16 (A)$
-20mA to +20mA	$A = 40D / 8191 - 20$	$D = 8191 / 40 (A + 20)$

For example, if you are using the -10V to +10V range and you have measured the signal at 6V, you would use this formula to determine the digital value that should be stored in the V-memory location that contains the data.

$$D = 8191 / 20 (A + 10)$$

$$D = 8191 / 20 (6V + 10)$$

$$D = (409.55) (16)$$

$$D = 6552$$

T1F-08DA-x, Analog Output Module Memory Map

8-Channel Analog Output Module (T1F-08DA-x)

Image Table Mapping

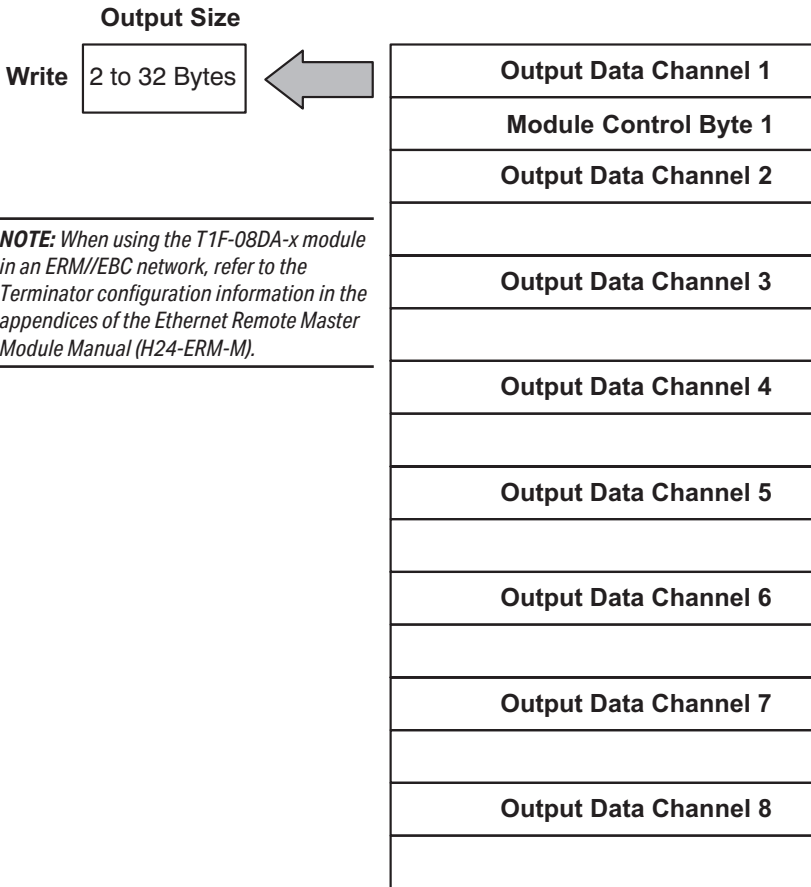
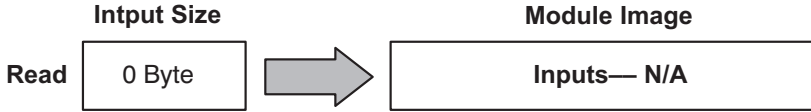

NOTE: When using the T1F-08DA-x module in an ERM//EBC network, refer to the Terminator configuration information in the appendices of the Ethernet Remote Master Module Manual (H24-ERM-M).



NOTE: Refer to page 4-21, Analog Output Module Control Byte.

T1F-08DA-x, Analog Output Module Memory Map, cont'd

Memory Map of 8-Channel Analog Output Module										
Decimal Bit	07	06	05	04	03	02	01	00	Size	
Octal Bit	07	06	05	04	03	02	01	00		
									Not Used	Read Byte 1
									Analog Value Channel 1	Write Byte 1
									Analog Value Channel 1	Write Byte 2
									Not Used	Byte 3
									Module Control Byte 1	Write Byte 4
									Analog Value Channel 2	Write Byte 5
									Analog Value Channel 2	Write Byte 6
									Not Used	Byte 7
									Reserved for future use	Byte 8
									Analog Value Channel 3	Write Byte 9
									Analog Value Channel 3	Write Byte 10
									Not Used	Byte 11
									Reserved for future use	Byte 12
									Analog Value Channel 4	Write Byte 13
									Analog Value Channel 4	Write Byte 14
									Not Used	Byte 15
									Reserved for future use	Byte 16
									Analog Value Channel 5	Write Byte 17
									Analog Value Channel 5	Write Byte 18
									Not Used	Byte 19
									Reserved for future use	Byte 20
									Analog Value Channel 6	Write Byte 21
									Analog Value Channel 6	Write Byte 22
									Not Used	Byte 23
									Reserved for future use	Byte 24
									Analog Value Channel 7	Write Byte 25
									Analog Value Channel 7	Write Byte 26
									Not Used	Byte 27
									Reserved for future use	Byte 28
									Analog Value Channel 8	Write Byte 29
									Analog Value Channel 8	Write Byte 30
									Not Used	Byte 31
									Reserved for future use	Byte 32



NOTE: Refer to page 4-21, Analog Output Module Control Byte

T1F-16DA-x, Analog Output Module Memory Map, cont'd

16-Channel Analog Output Module (T1F-16DA-x) Image Table Mapping

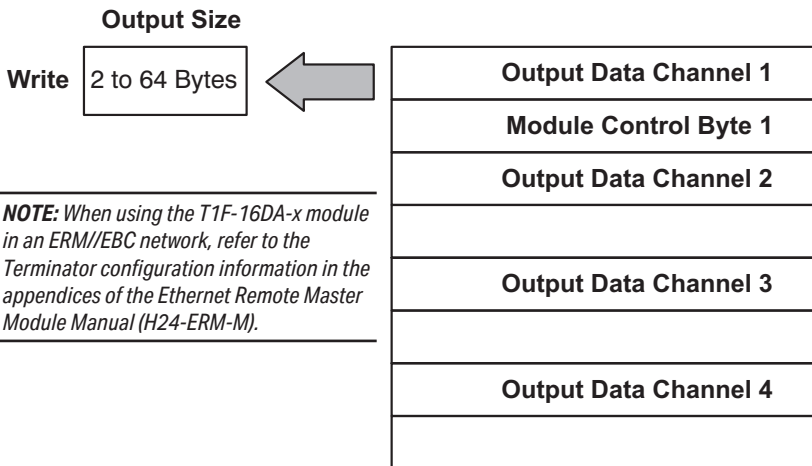
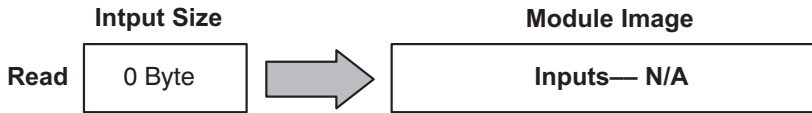

NOTE: When using the T1F-16DA-x module in an ERM//EBC network, refer to the Terminator configuration information in the appendices of the Ethernet Remote Master Module Manual (H24-ERM-M).



NOTE: Refer to page 4-21, Analog Output Module Control Byte



T1F-16DA-x, Analog Output Module Memory Map, cont'd

Memory Map of 16-Channel Analog Output Module										
Decimal Bit	07	06	05	04	03	02	01	00	Size	
Octal Bit	07	06	05	04	03	02	01	00		
									Not Used	Read Byte 1
									Analog Value Channel 1	Write Byte 1
									Analog Value Channel 1	Write Byte 2
									Not Used	Byte 3
									Module Control Byte 1 (See Note)	Write Byte 4
									Analog Value Channel 2	Write Byte 5
									Analog Value Channel 2	Write Byte 6
									Not Used	Byte 7
									Reserved for future use	Byte 8
									Analog Value Channel 3	Write Byte 9
									Analog Value Channel 3	Write Byte 10
									Not Used	Byte 11
									Reserved for future use	Byte 12
									Analog Value Channel 4	Write Byte 13
									Analog Value Channel 4	Write Byte 14
									Not Used	Byte 15
									Reserved for future use	Byte 16
									Analog Value Channel 5	Write Byte 17
									Analog Value Channel 5	Write Byte 18
									Not Used	Byte 19
									Reserved for future use	Byte 20
									Analog Value Channel 6	Read Byte 21
									Analog Value Channel 6	Read Byte 22
									Not Used	Byte 23
									Reserved for future use	Byte 24
									Analog Value Channel 7	Write Byte 25
									Analog Value Channel 7	Write Byte 26
									Not Used	Byte 27
									Reserved for future use	Byte 28
									Analog Value Channel 8	Write Byte 29
									Analog Value Channel 8	Write Byte 30
									Not Used	Byte 31
									Reserved for future use	Byte 32

(Memory Map table continued on following page.)



NOTE: Refer to page 4-21, Analog Output Module Control Byte

T1F-16DA-x, Analog Output Module Memory Map, cont'd

Memory Map of 16-Channel Analog Output Module									
Decimal Bit	07	06	05	04	03	02	01	00	Size
Octal Bit	07	06	05	04	03	02	01	00	
			Analog Value Channel 9						Write Byte 33
			Analog Value Channel 9						Write Byte 34
			Not Used						Byte 35
			Reserved for future use						Byte 36
			Analog Value Channel 10						Write Byte 37
			Analog Value Channel 10						Write Byte 38
			Not Used						Byte 39
			Reserved for future use						Byte 40
			Analog Value Channel 11						Write Byte 41
			Analog Value Channel 11						Write Byte 42
			Not Used						Byte 43
			Reserved for future use						Byte 44
			Analog Value Channel 12						Write Byte 45
			Analog Value Channel 12						Write Byte 46
			Not Used						Byte 47
			Reserved for future use						Byte 48
			Analog Value Channel 13						Write Byte 49
			Analog Value Channel 13						Write Byte 50
			Not Used						Byte 51
			Reserved for future use						Byte 52
			Analog Value Channel 14						Write Byte 53
			Analog Value Channel 14						Write Byte 54
			Not Used						Byte 55
			Reserved for future use						Byte 56
			Analog Value Channel 15						Write Byte 57
			Analog Value Channel 15						Write Byte 58
			Not Used						Byte 59
			Reserved for future use						Byte 60
			Analog Value Channel 16						Write Byte 61
			Analog Value Channel 16						Write Byte 62
			Not Used						Byte 63
			Reserved for future use						Byte 64

T1F-8AD4DA-x, Analog Output Module Memory Map

8-Channel Analog Input / 4-Channel Analog Output Module (T1F-8AD4DA-x)

Input Image Table Mapping

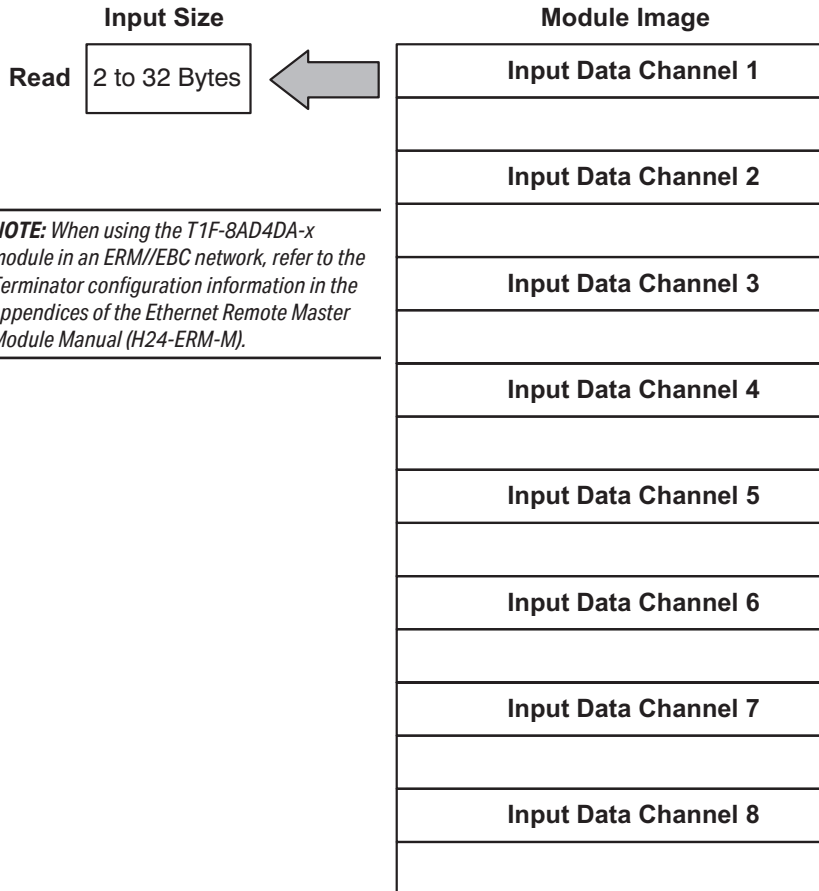

NOTE: When using the T1F-8AD4DA-x module in an ERM/EBC network, refer to the Terminator configuration information in the appendices of the Ethernet Remote Master Module Manual (H24-ERM-M).

T1F-8AD4DA-x, Analog Output Module Memory Map, cont'd

8-Channel Analog Input / 4-Channel Analog Output Module (T1F-8AD4DA-x)

Output Image Table Mapping

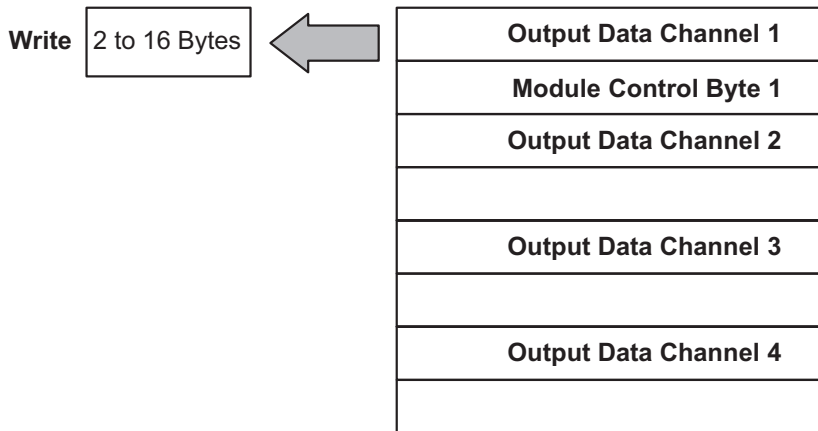

NOTE: Refer to page 4-21, Analog Output Module Control Byte

T1F-8AD4DA-x, Analog Output Module Memory Map, cont'd

Memory Map of 8 Analog Input Channels of the T1F-8AD4DA-x										
Decimal Bit	07	06	05	04	03	02	01	00	Size	
Octal Bit	07	06	05	04	03	02	01	00		
									Analog Value Channel 1	Read Byte 1
									Analog Value Channel 1	Read Byte 2
									Not Used	Byte 3
									Reserved for future use	Byte 4
									Analog Value Channel 2	Read Byte 5
									Analog Value Channel 2	Read Byte 6
									Not Used	Byte 7
									Reserved for future use	Byte 8
									Analog Value Channel 3	Read Byte 9
									Analog Value Channel 3	Read Byte 10
									Not Used	Byte 11
									Reserved for future use	Byte 12
									Analog Value Channel 4	Read Byte 13
									Analog Value Channel 4	Read Byte 14
									Not Used	Byte 15
									Reserved for future use	Byte 16
									Analog Value Channel 5	Read Byte 17
									Analog Value Channel 5	Read Byte 18
									Not Used	Byte 19
									Reserved for future use	Byte 20
									Analog Value Channel 6	Read Byte 21
									Analog Value Channel 6	Read Byte 22
									Not Used	Byte 23
									Reserved for future use	Byte 24
									Analog Value Channel 7	Read Byte 25
									Analog Value Channel 7	Read Byte 26
									Not Used	Byte 27
									Reserved for future use	Byte 28
									Analog Value Channel 8	Read Byte 29
									Analog Value Channel 8	Read Byte 30
									Not Used	Byte 31
									Reserved for future use	Byte 32

(Memory Map table continued on following page.)

T1F-8AD4DA-x, Analog Output Module Memory Map, cont'd

Memory Map of the 4-Analog Output Channels of the T1F-8AD4DA-x									
Decimal Bit	07	06	05	04	03	02	01	00	Size
Octal Bit	07	06	05	04	03	02	01	00	
	Analog Value Channel 1								Write Byte 1
	Analog Value Channel 1								Write Byte 2
	Not Used								Byte 3
	Module Control Byte								Write Byte 4
	Analog Value Channel 2								Write Byte 5
	Analog Value Channel 2								Write Byte 6
	Not Used								Byte 7
	Reserved for future use								Byte 8
	Analog Value Channel 3								Write Byte 9
	Analog Value Channel 3								Write Byte 10
	Not Used								Byte 11
	Reserved for future use								Byte 12
	Analog Value Channel 4								Write Byte 13
	Analog Value Channel 4								Write Byte 14
	Not Used								Byte 15
	Reserved for future use								Byte 16



NOTE: Refer to page 4-21 through 4-24 for Analog Output Module Control Byte configuration.

Analog Output Module Control Byte

Terminator I/O analog input/output voltage and current combination analog modules require configuring via the module control byte. Analog input modules do not require configuration.

Channel 1 Memory Map of 8 & 16 Channel Analog Output Module									
Decimal Bit	07	06	05	04	03	02	01	00	Size
Octal Bit	07	06	05	04	03	02	01	00	
	Analog Value Channel 1								Write Byte 1
	Analog Value Channel 1								Write Byte 2
	Not Used								Byte 3
	Module Control Byte (See note 1)								Write Byte 4

Module Control Byte of 8 & 16 Channel Analog Output Module									
Decimal Bit	31	30	29	28	27	26	25	24	Read / Write
Octal Bit	37	36	35	34	33	32	31	30	
Bit 24	Outputs Enable 0 = All Outputs OFF 1 = All Outputs Enabled								Write
Bit 25	Unipolar / Bipolar 0 = Unipolar Selected 1 = Bipolar Selected								Write
Bit 26	5V / 10V Range 0 = 5V Range 1 = 10V Range								Write
Bit 27	0-20 mA / 4-20 mA Range 0 = 0-20 mA Range 1 = 4-20 mA Range								Write
Bit 28-31	Reserved for system use.								--



NOTE 1: Module Control Byte is only used when used in an EBC/ERM rack configuration slot. See following pages for Module Control Byte setup.

NOTE 2: The 4-20 mA Range cannot be selected at the same time as the Bipolar or 10V Ranges.

The DirectLOGIC example below shows an ERM network Terminator I/O slave with a discrete input module in slot 1, an analog voltage output module in slot 2 and a combination analog current module in slot 3. Note that the module control bytes are automatically mapped to the “Y” data type registers. The bits within the module control byte are used to enable or disable the analog outputs, select bipolar or unipolar output and select the voltage or current output range. For Do-more applications, the control bits are mapped to DLY addresses, an example is shown below.

DirectLOGIC

ERM Module [00 E0 62 20 13 E2] - ERM Workbench

Ethernet Remote Master: H2-ERM Ethernet Address: 00 E0 62 20 13 E2 IP: 255.255.255.255 Module ID: 0

CPU Interface: PLC CPU: 260

Last ERM Error: no error PLC Mode: Program

Slave Status: 1 2 3 4 5 6 7 8 9 10 11 12 13 14 15 16

Click on slave # above to see its Last Error. Slave 1 - no error

Buttons: Read ERM Status, Detailed ERM Status..., Clear Last Error Slave 1, Slave 1's Error List

I/O Module	I/O Points	PLC Start	PLC End	V-Map	Notes
<reserved>	Slave Status Bits	X300	X317	V40414	
	ERM Status Word	X320	X337	V40415	
	Disable Slave Comm...	Y300	Y317	V40514	
Slave 1	T1H-ERC				hotswap(auto);Ethernet Address[00 E0 62 40 06 34] on IPX;
Slave 1/Slot 1	8 Discrete Input	X340	X347	V40416 Lo(0-7)	
Slave 1/Slot 2	8 Double Word Output	Y310	Y317		32-bit Binary;
	8 Discrete Output	Y320	Y327	V40515 Lo(0-7)	
	8 Double Word Input	V2000	V2017		32-bit Binary;
Slave 1/Slot 3	4 Double Word Output	V2120	V2127		32-bit Binary;
	8 Discrete Output	Y330	Y337	V40515 Hi(8-15)	

Do-more

ERM Module [00 E0 62 21 63 C4] - ERM Workbench

Ethernet Remote Master: H2-ERM100 Ethernet Address: 00 E0 62 21 63 C4 IP: 10. 1. 49. 2 Module ID: 0

CPU Interface: PLC CPU: Do-more

Last ERM Error: no error PLC Mode: Program

Slave Status: 1 2 3 4 5 6 7 8 9 10 11 12 13 14 15 16

Click on slave # above to see its Last Error. Slave 1 - no error

Buttons: Read ERM Status, Detailed ERM Status..., Clear Last Error Slave 1, Slave 1's Error List

I/O Module	I/O Points	PLC Start	PLC End	V-Map	Notes
<reserved>	Slave Status Bits	DLX300	DLX317		
	ERM Status Word	DLX320	DLX337		
	Disable Slave Command Bits	DLY300	DLY317		
Slave 1	T1H-ERC				hotswap(auto);Ether...
Slave 1/Slot 1	8 Double Word Output	DLY2000	DLY2017		32-bit Binary;
	8 Discrete Output	DLY320	DLY327		
Slave 1/Slot 2	8 Double Word Input	DLY2020	DLY2037		32-bit Binary;
	4 Double Word Output	DLY2040	DLY2047		32-bit Binary;
	8 Discrete Output	DLY330	DLY337		

Annotations:

- Module Control Byte for each analog output module (points to Y320-Y327 and Y330-Y337 in DirectLOGIC)
- T1F-08DA-2 (points to Slave 1/Slot 1 in both)
- T1F-8AD4DA-1 (points to Slave 1/Slot 2 in both)
- Control Bytes are mapped to DLY addresses in Do-more applications (points to DLY320-DLY327 and DLY330-DLY337 in Do-more)

The table below defines the bits of an analog module control byte. Example “Y” bit addresses are listed for the analog module control bytes from the ERM network example on the previous page, along with their equivalent Do-more addresses. The module control byte addresses will vary depending on the location of the analog module in the system, the number of slaves, the amount of output modules used in an ERM network and the starting discrete output address that is user specified. ERM Workbench will list the appropriate control byte for any Terminator analog module that requires configuration.

The following ladder logic code examples configure the analog output and combination analog modules used in the previous examples. The T1F-08DA-2 is configured for outputs enabled with 10V bipolar range. The T1F-8AD4DA-1 is configured for outputs enabled with 4-20mA unipolar range. The RST instruction can be used to reset the bits, if necessary.

Module Control Byte of 8 and 16-Channel Analog Output Modules and Analog Combination Modules			
Bit Definitions		Example Bit Addresses for T1F-08DA-2	Example Bit Addresses for T1F-8AD4DA-1
Bit 0	Outputs Enable 0 = All outputs OFF 1 = All outputs Enabled	DL: Y320 Do-more: DLY320	DL: Y330 Do-more: DLY330
Bit 1	Unipolar / Bipolar 0 = Unipolar selected 1 = Bipolar selected	DL: Y321 Do-more: DLY321	DL: Y331 Do-more: DLY331
Bit 2	5V / 10V Range 0 = 5V range 1 = 10V range	DL: Y322 Do-more: DLY322	DL: Y332 Do-more: DLY332
Bit 3	0-20mA / 4-20mA Range 0 = 0-20mA range 1 = 4-20mA range	DL: Y323 Do-more: DLY323	DL: Y333 Do-more: DLY333
Bit 4-7	Reserved for system use	-	-

DirectSOFT

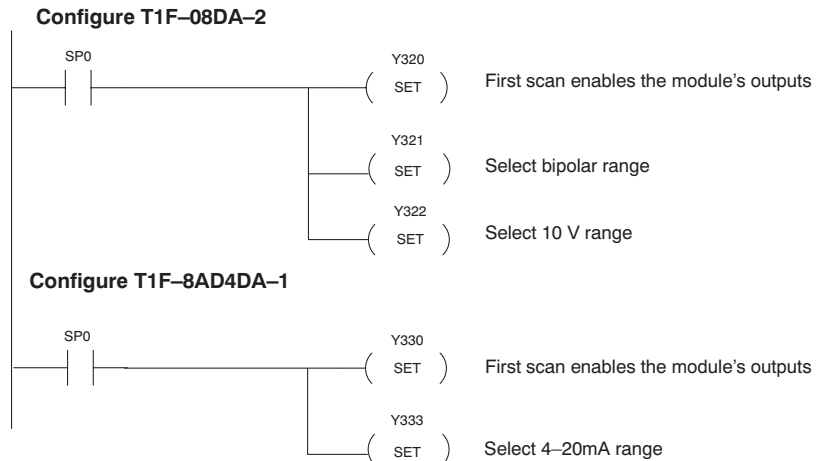

Do-more Designer

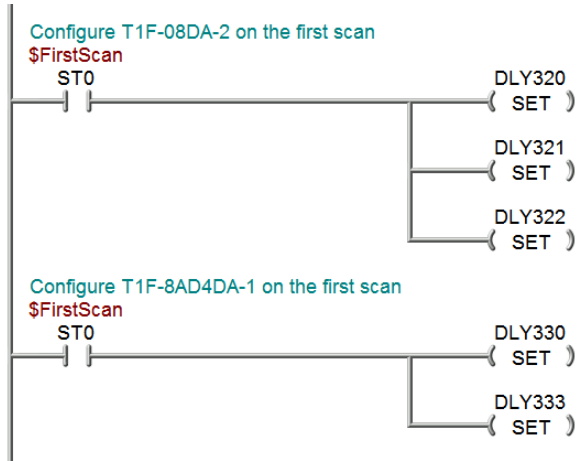

Analog Output Module Resolution

Output Module Resolution

Since the module has 12-bit resolution, the analog signal is converted into 4096 counts ranging from 0–4095 (2^{12}). For example, with a 0 to 10V scale, a 0V signal would be 0, and a 10V signal would be 4095. This is equivalent to a binary value of 0000 0000 0000 to 1111 1111 1111, or 000 to FFF hexadecimal. The following diagram shows how this relates to each signal range.

Current Output Module Resolution

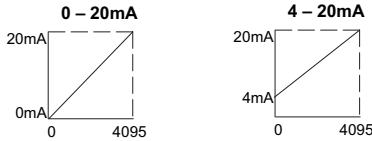

Voltage Output Module Resolution

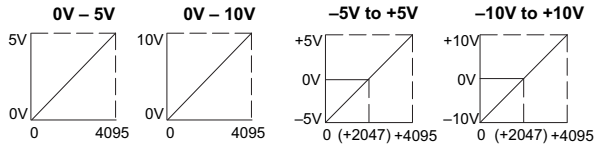

Channel Data Bits

The first bits represent the analog data in binary format.

Bit	Value	Bit	Value
0	1	6	64
1	2	7	128
2	4	8	256
3	8	9	512
4	16	10	1024
5	32	11	2048

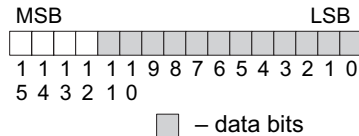

NOTE: Each analog channel uses 4 bytes. The first and second byte contain the analog data. The third and fourth byte are not used at this time.

Each count can also be expressed in terms of the signal level by using the equation shown at right. The following table shows the smallest signal level that will result in a change in the data value for each signal range.

$$\text{Smallest Detectable Change} = \frac{H - L}{\text{Resolution}}$$

H = high limit of the signal range

L = low limit of the signal range

Range	Signal Span (H - L)	Divide By	Smallest Detectable Change
±10V	20V	4095	4.88 mV
±5V	10V	4095	2.44 mV
0 to 5V	5V	4095	1.22 mV
0 to 10V	10V	4095	2.44 mV
0 to 20mA	20mA	4095	4.88 µA
4 to 20mA	16mA	4095	3.91 µA

Analog and Digital Value Conversions

Sometimes it is helpful to be able to quickly convert between the signal levels and the digital values. This is especially useful during machine startup or troubleshooting. The following table provides formulas to make this conversion easier.

Range	If you know the digital value...	If you know the analog value...
0 to 5V	$A = 5D / 4095$	$D = 4095 / 5 (A)$
0 to 10V	$A = 10D / 4095$	$D = 4095 / 10 (A)$
±5V	$A = 10D / 4095 - 5$	$D = 4095 / 10 (A + 5)$
±10V	$A = 20D / 4095 - 10$	$D = 4095 / 20 (A + 10)$
0 to 20mA	$A = 20D / 4095$	$D = 4095 / 20 (A)$
4 to 20mA	$A = 16D / 4095 + 4$	$D = 4095 / 16 (A - 4)$

For example, if you are using the -10V to +10V range and you have measured the signal at 6V, you would use this formula to determine the digital value that should be stored in the V-memory location that contains the data.

$$D = 4095 / 20 (A + 10)$$

$$D = 4095 / 20 (6V + 10)$$

$$D = (204.75) (16)$$

$$D = 3276$$

EUROPEAN UNION DIRECTIVES (CE)



In This Appendix:

European Union (EU) Directives	A-2
Basic EMC Installation Guidelines	A-5

European Union (EU) Directives



NOTE: *The information contained in this section is intended as a guideline and is based on our interpretation of the various standards and requirements. Since the actual standards are issued by other parties, and in some cases governmental agencies, the requirements can change over time without advance warning or notice. Changes or additions to the standards can possibly invalidate any part of the information provided in this section.*

This area of certification and approval is absolutely vital to anyone who wants to do business in Europe. One of the key tasks that faced the EU member countries and the European Economic Area (EEA) was the requirement to bring several similar yet distinct standards together into one common standard for all members. The primary purpose of a single standard was to make it easier to sell and transport goods between the various countries and to maintain a safe working and living environment. The Directives that resulted from this merging of standards are now legal requirements for doing business in Europe. Products that meet these Directives are required to have a CE mark to signify compliance.

Member Countries

As of January 1, 2015, the members of the EU are Austria, Belgium, Bulgaria, Croatia, Republic of Cyprus, Czech Republic, Denmark, Estonia, Finland, France, Germany, Greece, Hungary, Ireland, Italy, Latvia, Lithuania, Luxembourg, Malta, Netherlands, Poland, Portugal, Romania, Slovakia, Slovenia, Spain, Sweden, and United Kingdom. Iceland, Liechtenstein, and Norway together with the EU members make up the European Economic Area (EEA) and all are covered by the Directives.

Applicable Directives

There are several Directives that apply to our products. Directives may be amended, or added, as required.

- **Electromagnetic Compatibility Directive (EMC)** — this Directive attempts to ensure that devices, equipment, and systems have the ability to function satisfactorily in an electromagnetic environment without introducing intolerable electromagnetic disturbance to anything in that environment.
- **Machinery Safety Directive** — this Directive covers the safety aspects of the equipment, installation, etc. There are several areas involved, including testing standards covering both electrical noise immunity and noise generation.
- **Low Voltage Directive** — this Directive is also safety related and covers electrical equipment that has voltage ranges of 50–1000 VAC and/or 75–1500 VDC.
- **Battery Directive** — this Directive covers the production, recycling, and disposal of batteries.

Compliance



NOTE: *As of July 22, 2017 ROHS has been added as an additional requirement for CE Compliance per Directive 2011/65/EU. All products bearing the CE mark must be ROHS compliant.*

Certain standards within each Directive already require mandatory compliance. The EMC Directive, which has gained the most attention, became mandatory as of January 1, 1996. The Low Voltage Directive became mandatory as of January 1, 1997.

Ultimately, we are all responsible for our various pieces of the puzzle. As manufacturers, we must test our products and document any test results and/or installation procedures that

are necessary to comply with the Directives. As a machine builder, you are responsible for installing the products in a manner which will ensure compliance is maintained. You are also responsible for testing any combinations of products that may (or may not) comply with the Directives when used together. The end user of the products must comply with any Directives that may cover maintenance, disposal, etc., of equipment or various components. *Although we strive to provide the best assistance available, it is impossible for us to test all possible configurations of our products with respect to any specific Directive. Because of this, it is ultimately your responsibility to ensure that your machinery (as a whole) complies with these Directives and to keep up with applicable Directives and/or practices that are required for compliance.*

This then is the product specific standard for CPUs and covers the low voltage and EMC directives as required for European CE certification. This standard has many tests together with test procedures and limits, but also references the below standards for some tests.

Productivity1000 systems, manufactured by FACTS Engineering, when properly installed and used, conform to the Electromagnetic Compatibility (EMC), Low Voltage Directive, and

IEC 60068	IEC 60417	IEC 60664	IEC 60695	IEC 60707	IEC 60947	IEC 60950	IEC 61000	IEC 61010	
2-1:1990 part 2 Test A	All Parts	1:1992 Part 1	2-1 (all sheets) Part 2	:1999	5-1:1997 Part 5-1	1:2001 Part 1	4-2:1995 Part 4-2	1:2001 Part 1	
2-2:1974 part 2 Test B		3:1992			7-1:2002 Part 7-1		4-3:2002 Part 4-3		
2-6:1995 Part 2: Test Fc							4-4:1995		
2-6:1995 Part 2: Test Fc		CISPR 11:1999					4-5:1995 Part 4-5		
2-14:1984 Part 2 Test N		CISPR 16-1:1999 Part 1					4-6:1996 Part 4-6		
2-27:1987 Part 2 Test Ea		CISPR 16-2:1999 Part 2					4-8:1993 Part 4-8		
2-30:1980 Part 2 Test Db		For undated references, the latest edition of the referenced document (including any amendments) applies.						4-12:1995 Part 4-12	
2-31:1969 Part Test Ec									
2-32:1975 Part 2 Test Ed									

Machinery Directive requirements of the following standards:

• **Product Specific Standard for Programmable Controllers**

EN61131-2:2007 EMC, EN61010-2:2010 and EN61010-2-201: 2013 Safety Programmable controllers, equipment requirements and tests.

• **Warning on Electrostatic Discharge (ESD)**

We recommend that all personnel take necessary precautions to avoid the risk of transferring static charges to inside the control cabinet, and clear warnings and instructions should be provided on the cabinet exterior. Such precautions may include the use of earth straps, grounding mats and similar static-control devices, or the powering off of the equipment inside the enclosure before the door is opened.

- **Warning on Radio Interference (RFI)**

This is a class A product. In a domestic environment this product may cause radio interference in which case the user may be required to take adequate measures.

General Safety

- External switches, circuit breaker or external fusing, are required for these devices.
- The switch or circuit breaker should be mounted near the programmable controller equipment.

Special Installation Manual

The installation requirements to comply with the requirements of the Machinery Directive, EMC Directive and Low Voltage Directive are slightly more complex than the normal installation requirements found in the United States. To help with this, we have published a special manual which you can order or download from our website:

- DA-EU-M – EU Installation Manual that covers special installation requirements to meet the EU Directive requirements. Refer to this manual for updated information.

Other Sources of Information

Although the EMC Directive gets the most attention, other basic Directives, such as the Machinery Directive and the Low Voltage Directive, also place restrictions on the control panel builder. Because of these additional requirements it is recommended that the following publications be purchased and used as guidelines:

- BSI publication BS TH 42073: November 2000 – covers the safety and electrical aspects of the Machinery Directive
- EN 60204–1:2006 – Safety of Machinery; General electrical requirements for machinery, including Low Voltage and EMC considerations
- IEC 61000–5–2: EMC earthing and cabling requirements
- EC 61000–5–1: EMC general considerations

It may be possible for you to obtain this information locally; however, the official source of applicable Directives and related standards is:

Publications Office
2, rue Mercier
2985 Luxembourg
LUXEMBOURG

Quickest contact is via the web at:

<http://ec.europa.eu/growth/single-market/european-standards/harmonised-standards>.

Another source is the British Standards Institution at:

British Standards Institution – Sales Department, Linford Wood:

Milton Keynes, MK14 6LE, United Kingdom.

The quickest contact is via the web at www.bsigroup.com

Basic EMC Installation Guidelines

Enclosures

The following diagram illustrates good engineering practices supporting the requirements of the Machinery and Low Voltage Directives. House all control equipment in an industry standard lockable steel enclosure and use metallic conduit for wire runs and cables.

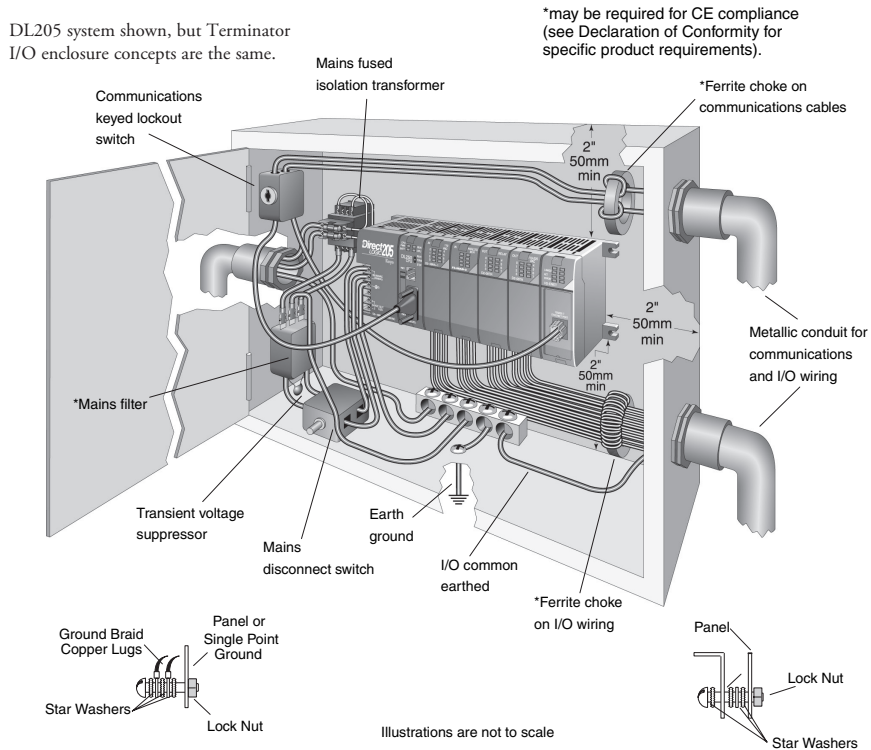

Electrostatic Discharge (ESD)

We specify in all declarations of conformity that our products are installed inside an industrial enclosure using metallic conduit for external wire runs; therefore, we test the products in a typical enclosure. However, we would like to point out that although our products operate normally in the presence of ESD, this is only the case when mounted within an enclosed industrial control cabinet. When the cabinet is open during installation or maintenance, the equipment and or programs may be at risk of damage from ESD carried by personnel.

We therefore recommend that all personnel take necessary precautions to avoid the risk of transferring static electricity to components inside the control cabinet. If necessary, clear warnings and instructions should be provided on the cabinet exterior, such as recommending the use of earth straps of similar devices, or the powering off of equipment inside the enclosure.

AC Mains Filters

The DL305 AC powered base power supplies require extra mains filtering to comply with the EMC Directive on conducted RF emissions. All PLC and Terminator I/O equipment has been tested with filters from Schaffner, which reduce emissions levels if the filters are properly grounded (earth ground). A filter with a current rating suitable to supply all PLC or Terminator I/O power supplies and AC input modules should be selected. We suggest the FN2080 for DL305 systems.

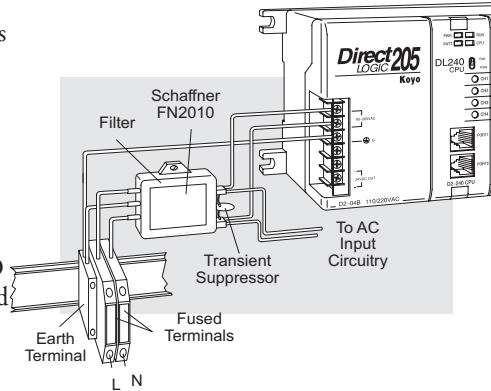

NOTE: Very few mains filters can reduce problem emissions to negligible levels. In some cases, filters may increase conducted emissions if not properly matched to the problem emissions.

Suppression and Fusing

In order to comply with the fire risk requirements of the Low Voltage and Machinery Directive electrical standards EN 61010–1, and EN 60204–1, by limiting the power into “unlimited” mains circuits with power leads reversed, it is necessary to fuse both AC and DC supply inputs. You should also install a transient voltage suppressor across the power input connections of the PLC or Terminator I/O. Choose a suppressor such as a metal oxide varistor, with a rating of 275 VAC working voltage for 230 V nominal supplies (150 VAC working voltage for 115 V supplies) and high energy capacity (eg. 140 joules).

Transient suppressors must be protected by fuses and the capacity of the transient suppressor must be greater than the blow characteristics of the fuses or circuit breakers to avoid a fire risk. A recommended AC supply input arrangement for Koyo PLCs and Terminator I/O is to use twin 3 amp TT fused terminals with fuse blown indication, such as DINnectors DN–F10L terminals, or twin circuit breakers, wired to a Schaffner FN2010 filter or equivalent, with high energy transient suppressor soldered directly across the output terminals of the filter. PLC and Terminator I/O system inputs should also be protected from voltage impulses by deriving their power from the same fused, filtered, and surge-suppressed supply.

Internal Enclosure Grounding

A heavy-duty star earth terminal block should be provided in every cubicle for the connection of all earth ground straps, protective earth ground connections, mains filter earth ground wires, and mechanical assembly earth ground connections. This should be installed to comply with safety and EMC requirements, local standards, and the requirements found in IEC 1000–5–2. The Machinery Directive also requires that the common terminals of PLC or Terminator I/O input modules, and common supply side of loads driven from PLC or Terminator I/O output modules should be connected to the protective earth ground terminal.

Equi-potential Grounding

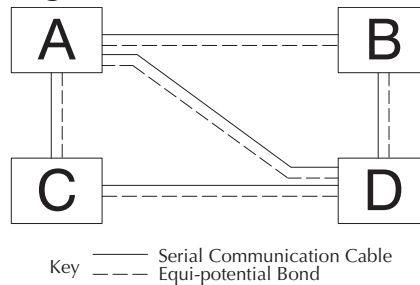

Adequate site earth grounding must be provided for equipment containing modern electronic circuitry. The use of isolated earth electrodes for electronic systems is forbidden in some countries. Make sure you check any requirements for your particular destination. IEC 1000–5–2 covers equi-potential bonding of earth grids adequately, but special attention should be given to apparatus and control cubicles that contain I/O devices, remote I/O racks, or have inter-system communications with the primary PLC or Terminator I/O system enclosure. An equi-potential bond wire must be provided alongside all serial communications cables, and to any separate items of the plant which contain I/O devices connected to the PLC or Terminator I/O system. The diagram shows an example of four physical locations connected by a communications cable.

Communications and Shielded Cables

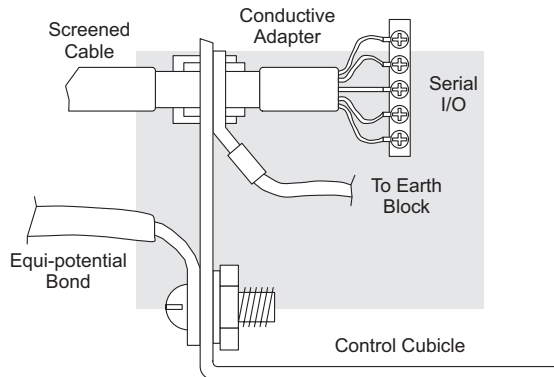

Good quality 24 AWG minimum twisted-pair shielded cables, with overall foil and braid shields are recommended for analog cabling and communications cabling outside of the PLC or Terminator I/O enclosure. To date it has been a common practice to only provide an earth ground for one end of the cable shield in order to minimize the risk of noise caused by earth ground loop currents between apparatus. The procedure of only grounding one end, which primarily originated as a result of trying to reduce hum in audio systems, is no longer applicable to the complex industrial environment. Shielded cables are also efficient emitters of RF noise from the PLC or Terminator I/O, system, and can interact in a parasitic manner in networks and between multiple sources of interference.

The recommendation is to use shielded cables as electrostatic “pipes” between apparatus and systems, and to run heavy gauge equi-potential bond wires alongside all shielded cables. When a shielded cable runs through the metallic wall of an enclosure or machine, it is recommended in IEC 1000–5–2 that the shield should be connected over its full perimeter to the wall, preferably using a conducting adapter, and not via a pigtail wire connection to an earth ground bolt. Shields must be connected to every enclosure wall or machine cover that they pass through.

Analog and RS-232C Cables

Providing an earth ground for both ends of the shield for analog circuits provides the perfect electrical environment for the twisted pair cable as the loop consists of signal and return, in a perfectly balanced circuit arrangement, with connection to the common of the input circuitry made at the module terminals. RS-232C cables are handled in the same way.

Multidrop Cables

RS-422 twin twisted pair, and RS-485 single twisted pair cables also require a 0 V link, which has often been provided in the past by the cable shield. It is now recommended that you use triple twisted pair cabling for RS-422 links, and twin twisted pair cable for RS-485 links. This is because the extra pair can be used as the 0V inter-system link. With loop DC power supplies earth grounded in both systems, earth loops are created in this manner via the inter-system 0v link. The installation guides encourage earth loops, which are maintained at a low impedance by using heavy equi-potential bond wires. **To account for non-European installations using single-end earth grounds, and sites with far from ideal earth ground characteristics, we recommend the addition of 100 ohm resistors at each 0 V link connection in network and communications cables.**

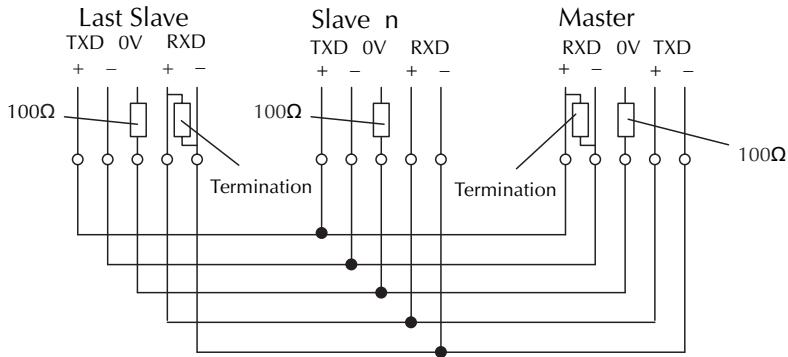

Shielded Cables within Enclosures

When you run cables between PLC or Terminator I/O items within an enclosure which also contains susceptible electronic equipment from other manufacturers, remember that these cables may be a source of RF emissions. There are ways to minimize this risk. Standard data cables connecting PLCs, Terminator I/O and/or operator interfaces should be routed well away from other equipment and their associated cabling. You can make special serial cables where the cable shield is connected to the enclosure's earth ground at both ends, the same way as external cables are connected.

Analog Modules and RF Interference

The readings from all analog modules will be affected by the use of devices that exhibit high field strengths, such as mobile phones and motor drives.

All Automationdirect products are tested to withstand field strength levels up to 10 V/m, which is the maximum required by the relevant EU standards. While all products pass this test, analog modules will typically exhibit deviations of their readings. This is quite normal, however, systems designers should be aware of this and plan accordingly.

When assembling a control system using analog modules, these issues must be adhered to and should be integrated into the system design. This is the responsibility of the system builder/commissioner.

Network Isolation

For safety reasons, it is a specific requirement of the Machinery Directive that a keyswitch must be provided that isolates any network input signal during maintenance, so that remote commands cannot be received that could result in the operation of the machinery. **The FA-ISONET does not have a keyswitch!** Use a keylock and switch on your enclosure which when open removes power from the FA-ISONET. To avoid the introduction of noise into the system, any keyswitch assembly should be housed in its own earth grounded steel box and the integrity of the shielded cable must be maintained.

Again, for further information on EU directives we recommend that you get a copy of our EU Installation Manual (DA-EU-M). Also, if you are connected to the World Wide Web, you can check the EU commission's official site at: http://ec.europa.eu/index_en.htm

DC Powered Versions

Due to slightly higher emissions radiated by the DC powered versions of the Terminator I/O system, and the differing emissions performance for different DC supply voltages, the following stipulations must be met:

- The Terminator I/O system must be housed within a metallic enclosure with a minimum amount of orifices.
- I/O and communications cabling exiting the cabinet must be contained within metallic conduit/trunking.

Items Specific to the Terminator I/O System

- The rating between all circuits in this product are rated as **basic insulation only**, as appropriate for single fault conditions.
- There is no isolation offered between the PLC or Terminator I/O system and the analog inputs of this product.
- It is the responsibility of the system designer to earth one side of all control and power circuits, and to earth the braid of screened cables.
- This equipment must be properly installed while adhering to the guidelines of the in house installation manual DA-EU-M, and the installation standards IEC 1000-5-1, IEC 1000-5-2 and IEC 1131-4.
- It is a requirement that all PLC or Terminator I/O equipment must be housed in a protective steel enclosure, which limits access to operators by a lock and power breaker. If access is required by operators or untrained personnel, the equipment must be installed inside an internal cover or secondary enclosure.
- It should be noted that the safety requirements of the machinery directive standard EN60204-1 state that all equipment power circuits must be wired through isolation transformers or isolating power supplies, and that one side of all AC and DC control circuits must be earthed.
- Both power input connections to the PLC or Terminator I/O must be separately fused using 3 amp T type anti-surge fuses, and a transient suppressor fitted to limit supply overvoltages.
- Please be aware of notification within the documentation that if the equipment is used in a manner not specified by the manufacturer the protection provided by the equipment may be impaired.
- Input power cables must be externally fused and have an externally mounted switch or circuit breaker, preferably mounted near the Terminator I/O system.
- When needed, carefully clean the outside plastic case of Terminator I/O components using a dry cloth.
- Only use replacement parts supplied by **AutomationDirect** or its agents.
- Cables, whether shielded or not, **MUST** be enclosed within earthed metal conduit or other metallic trunking when outside the Terminator I/O enclosure.
- This is a Class A product and it may cause radio interference in certain environments. The user may need to provide shielding, or other measures to eliminate the interference.