

STRIDE® SE2 SERIES INDUSTRIAL MANAGED ETHERNET SWITCHES



Safety Standards:



RoHS Compliant



NOTE: FOR ADDITIONAL PRODUCT DETAILS, A USER MANUAL, SE2-USER-M, IS AVAILABLE AS A DOWNLOADABLE PDF FILE FROM THE ONLINE DOCUMENTATION AREA OF THE AUTOMATIONDIRECT WEBSITE.

Stride SE2 Series Managed Models

Part Number	Ethernet Ports	Fiber Ports	Input Power (max)	Operating Temp	Agency Approvals
SE2-SW8M	8	-	8.1 W	-40 to +75°C (-40 to +167°F)	UL/cUL 508, Haz Loc, CE
SE2-SW8M-2P	6	2 GbE SFP*	9.1 W		
SE2-SW8M-2C1		2 SC	8.1 W		
SE2-SW8M-2T1		2 ST	8.1 W		
SE2-SW16M	16	-	18W		
SE2-SW18MG-2P	16, 2 GbE combo	2 GbE SFP combo*			

*Optional SFP modules sold separately.

RJ45 Ports

Port Type	Shielded RJ45
Ethernet Compliance	IEEE 802.3i, 802.3u, 802.3x for 10/100 Ethernet IEEE 802.3ab, 802.3z for Gigabit Ethernet
Auto-Crossover	Yes, allows you to use straight-through or crossover wired cables
Auto-Sensing Operation	Yes, full and half duplex
Auto-Negotiating Speed	Yes
Flow Control	Automatic
Cable Requirements	Twisted pair (Cat5e or better) (shielded recommended)
Max. Cable Distance	100 meters

SC or ST Fiber Port: (100BaseFX multimode)

100BaseFX Ports	2
Fiber Port Connector	ST or SC, by model
Optimal Fiber Cable	50/125 or 62.5/125 µm
Center Wavelength	1300 nm
Multimode	Links up to 4 km typ. > Transmitter power (dBm): -21 min, -17 typ, -14 max > Receiver sensitivity (dBm): -34 typ, -31 max
Nominal Max. Distance (full duplex)	4 km
Eye Safety (laser)	IEC 60825-1, Class 1; FDA 21 CFR 1040.10 and 1040.11

SFP Ports

SFP (pluggable) ports accept Mini-GBIC (SFP) transceivers with a speed of 1000Mbps or 100Mbps
See SFP datasheet for optional fiber transceiver specification

General Specifications

Operating Mode	Store and forward wire speed switching, non-blocking
Devices Supported	All IEEE 802.3 compliant devices are supported
MAC Addresses	8K 16K for SE2-SW8M-2P
Ethernet Protocols Supported	SNMPv1 / v2 / v3, RMON, DHCP, SNTIP, TFTP, STP, RSTP, QoS / DS, IGMPv1 / v2, VLAN (tag and port based), HTTP, HTTPS (SSL and TLS), Telnet, SSH and more
Industrial Protocols Supported	Modbus TCP, EtherNet/IP, PROFINET, Foundation Fieldbus HSE and others
Packet Forwarding Rate	1.4 Mpps - SE2-SW8M 1.4 Mpps - SE2-SW8M-2C1 1.4 Mpps - SE2-SW8M-2T1 5.5 Mpps - SE2-SW8M-2P 5.4 Mpps - SE2-SW16M 5.4 Mpps - SE2-SW18MG-2P
Latency	< 10 µs
Operating Temperature Range	-40 to +75°C (-40 to +167°F)
Storage Temperature Range	-40 to +85°C (-40 to +185°F)
Humidity (non-condensing)	5 to 95% RH
Environmental Air	No corrosive gases permitted
Vibration, Shock & Freefall	IEC60068-2-6, -27, -32
EMI Emissions	FCC CFR47 Part 15, EN55032/CISPR32, Class A
EMS	IEC61000-4-2 (ESD): ± 8kV (contact), ± 15kV (air) IEC61000-4-3 (RS): 10V/m (80MHz ~ 2GHz) IEC61000-4-4 (EFT): Power Port ± 4kV; Data Port: ± 2kV IEC61000-4-5 (Surge): Power Port: ± 2kV/DM, ± 4kV/CM; Data Port ± 2kV IEC61000-4-6 (CS): 10V (150kHz ~ 80MHz)
RoHS and WEEE	RoHS (Pb free) and WEEE compliant
Packaging and Protection	Metal case, IP40
Hazardous Locations	ANSI/ISA 12.12.01-2012 (Class I, Div.2) (file #E200031)
Agency Approvals	UL/cUL 508, CE

NOTE: THE FOLLOWING AUTOMATIONDIRECT PLC ETHERNET MODULES ARE NOT COMPATIBLE WITH THE STRIDE ETHERNET SWITCHES WITH FIBER OPTIC CONNECTIONS BECAUSE THE MODULES HAVE A SPEED OF 10BASEF (FIBER OPTIC) ONLY: ETHERNET COMMUNICATIONS MODULE, P/N H2-ECOM-F & H4-ECOM-F; ETHERNET BASE CONTROLLER MODULE, P/N H2-EBC-F & H4-EBC-F; ETHERNET REMOTE MASTER MODULE, P/N H2-ERM-F & H4-ERM-F.

Power Wiring:

The switch can be powered from the same DC source that is used to power your other devices. To maintain the UL508 listing, this must be a Class 2 power supply. A DC voltage in the range of 12 to 24 VDC needs to be applied between the P1+ terminal and the P1- terminal as shown below. The chassis screw terminal should be tied to panel or chassis ground. To reduce down time resulting from power loss, the switch can be powered redundantly with a second power supply as shown below.

A recommended DC power supply is AutomationDirect.com part number PSL-24-030.

Redundant DC Power

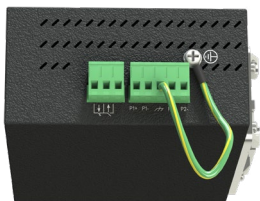
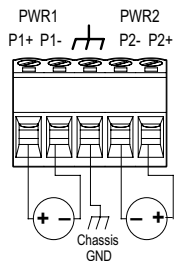

Power Details	
Power Input	Redundant Input Terminals
Input Voltage	Class 2 Power Supply: 12-24 VDC
Reverse Power Protection	Yes
Wire Size and Torque	18-12 AWG, max wire length 3m (9.84 ft); Wire strip length 7mm; Torque: 3.5 lb-in (0.4 N-m)
Power Consumption	Refer to Models table on page 1

RJ45 Port LEDs			
Type	LED	State	Description
10/100Base-T(X) RJ45 Port	Speed (Yellow)	On	100M connection detected
		Off	10M connection detected
	Link/ACT (Green)	On	Effective network connection on the port
		Blinking	Network activity on the port
		Off	No effective network connection on the port
		Off	No effective network connection on the port
10/100/1000 Base-T(X) RJ45 Port	Speed (Yellow)	On	1000M connection detected
		Off	10/100M connection detected
	Link/ACT (Green)	On	Effective network connection on the port
		Blinking	Network activity on the port
		Off	No effective network connection on the port
		Off	No effective network connection on the port

Reset:

The switch can be reset (power cycle) by pressing the RESET button on the face of the switch for 1-3 seconds.

The switch will be RESET to FACTORY DEFAULT by pressing the RESET button on the face of the switch for 5 seconds.

Alarm Terminal Wiring:

Alarm conditions may be configured in the switch, see the manual for details. When an alarm condition is true, the normally open contact closes and the normally closed contact opens.

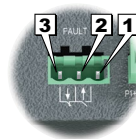

Communication Ports Wiring:

The switch provides connections to standard Ethernet devices such as PLCs, Ethernet I/O, industrial computers and much more. Use data-quality (not voice-quality) twisted pair cable rated Cat5e (or better) with standard RJ45 connectors. Straight-through or crossover RJ45 cable can be used for all devices the switch is connected to as all the ports are capable of auto-mdi/mdix-crossover detection.

The RJ45 Ethernet port connector bodies on the switch are metallic and connected to the Chassis GND terminal. Therefore, shielded cables may be used to provide further protection. To prevent ground loops, the cable shield should be tied to the metal connector body at one end of the cable only. Electrical isolation is also provided on the Ethernet ports for increased reliability.



NOTE: SIGNAL OUTPUT RATED VOLTAGE IS <30V.

Front Panel LEDs		
LED	State	Description
RUN	On	CPU is running abnormally or the switch is starting
	Blinking (1Hz)	CPU is running normally
	Off	CPU is not running
Alarm	On	System alarm
	Off	No system alarm
PWR1 LED	On	Power 1 connected and operational
	Off	Power 1 no voltage
PWR2 LED	On	Power 2 connected and operational
	Off	Power 2 no voltage
RING	On	Master (AD-Ring mode) / Root (ADP mode)
	Blinking	Slave (AD-Ring mode) / B-Root (ADP mode)
	Off	No ring mode

Installation – DIN Rail Mounting:

These devices are open-type and are meant to be installed in an enclosure which is only accessible with the use of a tool and suitable for the environment when installed in Class 1, Division 2 Hazardous Locations. The switch can be snapped onto a standard 35 mm x 7.5 mm height DIN rail (Standard: CENELEC EN50022) and can be mounted either vertically or horizontally. Allow 20mm (0.79”) clearance between an SE2 switch and other equipment on the DIN rail.

DIN rail mounting steps:

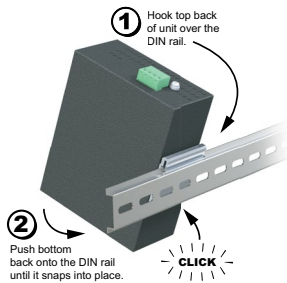

DIN rail removal steps:

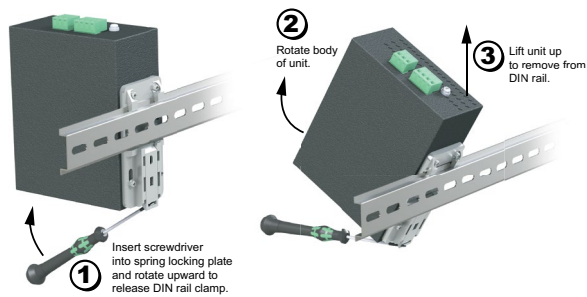

Dimensions:

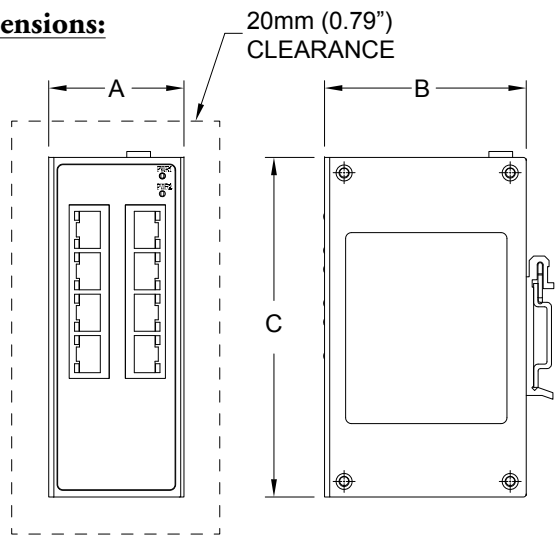

Dimensions				
Part No.	Weight kg [lb]	Width (A)	Depth (B)	Height (C)
		mm [inches]		
SE2-SW8M	0.76 [1.68]	53.6 [2.11]	106.5 [4.19]	135.0 [5.31]
SE2-SW8M-2C1				
SE2-SW8M-2T1				
SE2-SW8M-2P				
SE2-SW16M	1.25 [2.8]	88.0 [3.46]	137.0 [5.39]	
SE2-SW18MG-2P				

www.AutomationDirect.com

WARNING: The following information applies when operating this device in hazardous locations:

Suitable for use in Class 1, Division 2, Groups A, B, C and D Hazardous Locations, or nonhazardous locations only.

Cet appareillage est utilisable dans les emplacements de Classe 1, Division 2, Groupes A, B, C et D, ou dans les emplacements non dangereux seulement.

WARNING: EXPLOSION HAZARD

- Do not disconnect equipment while the circuit is live or unless the area is known to be free of ignitable concentrations.
- Substitution of any component may impair suitability for Class 1, Division 2.

AVERTISSEMENT: RISQUE D'EXPLOSION

- Avant de deconnecter l'equipement, couper le courant ou s'assurer que l'emplacement est designe non dangereux.
- La substitution de composants peut rendre ce materiel inacceptable pour les emplacements de Classe 1, Division 2.



Installation – Panel Mounting:

Refer to the user manual, SE2-USER-M, for panel mounting instructions. Panel mounting requires purchase of optional accessory item, SE2-PM3.

Additional Help and Support

- For additional product support, specifications, and installation, a User Manual, SE2-USER-M, is available as a downloadable PDF file from the Online Documentation area of www.AutomationDirect.com
- For additional technical support and questions, call our Technical Support team @ 770-844-4200.



1-800-633-0405