

# HARDWARE

---



# CHAPTER 1

## In this Chapter...

Introduction.....	1-2
Conventions Used.....	1-2
General Information.....	1-3
Product Overview Stride SE2 Unmanaged Models .....	1-5
Product Overview Stride SE2 PoE Unmanaged Models .....	1-6
Product Overview Stride SE2 Managed Models.....	1-7
Switch Accessories .....	1-8
SFP Fiber Transceivers.....	1-8
Mounting Brackets .....	1-9
DIP Switch (Unmanaged DIN rail mounted switches).....	1-10
Reset (Managed Switches).....	1-11
LED Indicators.....	1-12
Installation, DIN Rail Mounting .....	1-14
Installation, Optional Panel Mounting .....	1-16
Installation, IP65 Switches Panel Mounting .....	1-17
Dimensional Drawings.....	1-18
Power Wiring.....	1-26
Communication Ports Wiring.....	1-29
Technical Specifications.....	1-32
Unmanaged Models.....	1-32
Unmanaged PoE Models .....	1-34
Unmanaged IP65 Rated Models .....	1-36
Managed Models .....	1-38

## Introduction

### The Purpose of this User's Manual

Thank you for purchasing our **Stride**® SE2 series Industrial Ethernet Switches. This manual describes AutomationDirect.com's **Stride** industrial Ethernet switches, their specifications, included components, and provides you with important information for installation, connectivity and setup. The manual shows you how to install, wire and use the products.

### Technical Support

We strive to make our manuals the best in the industry. We rely on your feedback to let us know if we are reaching our goal. If you cannot find the solution to your particular application, or, if for any reason you need technical assistance, please call us at:

**770-844-4200**

Our technical support group will work with you to answer your questions. They are available Monday through Friday from 9:00 a.m. to 6:00 p.m. Eastern Time. We also encourage you to visit our web site where you can find technical and non-technical information about our products and our company.

**<http://www.automationdirect.com>**

If you have a comment, question or suggestion about any of our products, services, or manuals, please let us know.

## Conventions Used



---

When you see the “notepad” icon in the left-hand margin, the paragraph to its immediate right will be a special note. The word **NOTE**: in boldface will mark the beginning of the text.

---



---

When you see the “exclamation mark” icon in the left-hand margin, the paragraph to its immediate right will be a warning or a caution. This information could prevent injury, loss of property, or even death (in extreme cases). The words **WARNING** or **CAUTION**: in boldface will mark the beginning of the text.

---

## General Information

### Overview

This user's manual will help you install and maintain the **Stride** industrial Ethernet switches. Installation of these devices is very easy and they will begin to operate as soon as they are powered up.

### Operation

Unlike an Ethernet hub that broadcasts all messages out all ports, these industrial Ethernet switches will intelligently route Ethernet messages only out the appropriate port. The major benefits of this are increased bandwidth and speed, reduction or elimination of message collisions, and deterministic performance when tied with real-time systems.

These industrial Ethernet switches can support 10BaseT (10 Mbps) or 100BaseT (100 Mbps) or 1000BaseT (Gigabit Ethernet) on their RJ45 ports. Each of these ports will independently auto-sense the speed and duplex, mdi/mdix-crossover and polarity allowing you to use patch or crossover cables.

Some models include fiber optic ports, or slots that accept SFP fiber optic transceivers.

### Security Considerations

When implementing any method of remote access to your equipment, you need to consider the security exposure in order to minimize the risks to your processes and your equipment. Security should always be carefully evaluated for each installation. Refer to "Appendix F: Security Considerations for Control Systems Networks" for more information.

## Installation and Hazardous Area Warnings



**WARNING:** These products should not be used to replace proper safety interlocking. No software-based device (or any other solid-state device) should ever be designed to be responsible for the maintenance of consequential equipment or personnel safety. In particular, *AutomationDirect.com* disclaims any responsibility for damages, either direct or consequential, that result from the use of this equipment in any application. All power, input and output (I/O) wiring must be in accordance with Class 1, Division 2 wiring methods and in accordance with the authority having jurisdiction.

<b>WARNING (EXPLOSION HAZARD)</b>	SUBSTITUTION OF COMPONENTS MAY IMPAIR SUITABILITY FOR CLASS 1, DIVISION 2 (ZONE 2).
<b>WARNING (EXPLOSION HAZARD)</b>	WHEN IN HAZARDOUS LOCATIONS, DISCONNECT POWER BEFORE REPLACING OR WIRING UNITS.
<b>WARNING (EXPLOSION HAZARD)</b>	DO NOT DISCONNECT EQUIPMENT UNLESS POWER HAS BEEN SWITCHED OFF OR THE AREA IS KNOWN TO BE NONHAZARDOUS.
<b>WARNING (EXPLOSION HAZARD)</b>	IN HAZARDOUS OR POTENTIALLY HAZARDOUS LOCATIONS, DO NOT SEPARATE ANY PART OF THE UNIT WHEN ENERGIZED. USE THE UNIT FOR INTERNAL CONNECTIONS ONLY.

### FCC Statement

This equipment has been tested and found to comply with the limits for a Class A digital device, pursuant to part 15 of the FCC Rules. These limits are designed to provide reasonable protection against harmful interference when the equipment is operated in a commercial environment. This equipment generates, uses, and can radiate radio frequency energy and, if not installed and used in accordance with the instruction manual, may cause harmful interference to radio communications. Operation of this equipment in a residential area is likely to cause harmful interference in which case the user will be required to correct the interference at his own expense.



**NOTE:** Modifications to this equipment will void the user's authority to operate the equipment.

## Product Overview Stride SE2 Unmanaged Models



Stride SE2 Unmanaged Models							
Part Number	Number of Ports				Input power (max.)	Operating Temp	Agency Approvals
	M12 10/100	RJ45 10/100	RJ45 GbE	Fiber			
SE2-MC2U-C1-T	–	1	–	1 SC	3.4 W	-40 to +75°C (-40 to +167°F)	UL/cUL 61010-1 and 61010-2-201, Class 1, Div. 2, Groups A, B, C, D, (UL file #E200031) CE
SE2-MC2U-T1-T	–	1	–	1 ST			
SE2-SW5U	–	5	–	–		-10 to +60°C (+14 to +140°F)	
SE2-SW5U-T	–	5	–	–	4.5 W	-40 to +75°C (-40 to +167°F)	
SE2-SW5UG-T	–	–	5	–			
SE2-SW5U-1C1-T	–	4	–	1 SC	3.4 W	-10 to +60°C (+14 to +140°F)	
SE2-SW5U-1T1-T	–	4	–	1 ST			
SE2-SW8U	–	8	–	–	4.6 W	-10 to +60°C (+14 to +140°F)	
SE2-SW8U-T	–	8	–	–			
SE2-SW8U-2C1-T	–	6	–	2 SC			
SE2-SW8U-2T1-T	–	6	–	2 ST	10W	-40 to +75°C (-40 to +167°F)	
SE2-SW8UG-T	–	–	8	–			
SE2-SW10UG-2P-T	–	–	8	2 GbE SFP*	8W	-40 to +75°C (-40 to +167°F)	
SE2-SW16U-T	–	16	–	–			
SE2-SW18U-2G-T	–	16	2	–	4.6 W	-40 to +75°C (-40 to +167°F)	
SE2-SW5U-N65-T	5	–	–	–			
SE2-SW8U-N65-T	8	–	–	–			

**NOTE:** Optional SFP modules sold separately. Use only Gigabit speed SFPs with SE2-SW10UG-2P-T.

## Product Overview Stride SE2 PoE Unmanaged Models



Stride SE2 Unmanaged PoE Models						
Part Number	Number of Ports				Operating Temp	Agency Approvals
	RJ45 10/100	RJ45 GbE	RJ45 10/100 PoE	RJ45 GbE PoE		
<b>SE2-SWP5U-T</b>	1	–	4	–	-40 to +75°C (-40 to +167°F)	UL/cUL 61010-1 and 61010-2-201 Class 1, Div. 2, Groups A, B, C, D, (UL file #E200031) CE
<b>SE2-SWP5UG-T</b>	–	1	–	4		

## Product Overview Stride SE2 Managed Models



Stride SE2 Series Managed Models					
Part Number	Ethernet Ports	Fiber Ports	Input Power (max)	Operating Temp	Agency Approvals
<b>SE2-SW8M</b>	8	–	8.1 W	-40 to +75°C (-40 to +167°F)	UL/cUL 508, Class 1, Div. 2, Groups A, B, C, D, (UL file #E200031), CE
<b>SE2-SW8M-2P</b>	6	2 GbE SFP*	9.1 W		
<b>SE2-SW8M-2C1</b>		2 SC	8.1 W		
<b>SE2-SW8M-2T1</b>		2 ST	8.1 W		
<b>SE2-SW16M</b>	16	–	18W		
<b>SE2-SW18MG-2P</b>	16, 2 GbE combo	2 GbE SFP combo*			

\* Optional SFP modules sold separately.

## Switch Accessories

### SFP Fiber Transceivers

Stride SFP (small form-factor pluggable) transceivers, also called mini-GBIC, are compact, hot-swappable transceivers with LC fiber connectors. Models SE2-SW8M-2P, SE2SW18MG-2P, and SE2-SW10UG-2P-T have ports that accept these optional transceivers to add fiber connectivity at Fast Ethernet or Gigabit Ethernet speed.



---

**NOTE:** SE2-SW10UG-2P-T will only accept Gigabit speed SFPs.

---



SFP Fiber Transceivers				
Part Number	Mode	Data Rate	Light Source	Max Trans. Distance
<b>SFP-4K-FMF</b>	Multi-mode	Fast Ethernet (155MB)	1310 nm, FP	4km
<b>SFP-30K-FSF</b>	Single-mode			30 km
<b>SFP-500-GMF</b>	Multi-mode	Gigabit (1.25 GB)	850 nm, VCSEL	550m
<b>SFP-2K-GMF</b>			1310 nm, FP	2km
<b>SFP-10K-GSF</b>	Single-mode			1310 nm, FP
<b>SFP-30K-GSF</b>			1310 nm, DFB	30 km

## Mounting Brackets

SE2-PM1 and SE2-PM3 panel mounting brackets allow DIN rail mount models of **Stride** SE2 series Ethernet switches to be mounted to a panel or an appropriate flat surface.

- SE2-PM1 is compatible with SE2-SW5Ux, SE2-SW8U-x, and SE2-MCx
- SE2-PM3 is compatible with SE2-SWPx, SE2-SW8UG-T, SE2-SW10UG-2P-T, SE2-SW16U-T, SE2-SW18U-2G-T and all SE2 managed switches.

See the **Installation, Optional Panel Mounting** section later in this chapter for specific instructions.



## DIP Switch (Unmanaged DIN rail mounted switches)

DIP switch I enables the broadcast storm protection feature on the unmanaged DIN rail mounted switches. A broadcast storm is usually caused by a loop in the network and results in network traffic interruption. The broadcast storm protection feature is especially useful in a more complex network of many unmanaged switches, particularly when cables are disconnected and reconnected frequently.

DIP switch II provides different functions based on the model.

- DIP switch II - GbE switches - ON enables Jumbo frame support
- DIP switch II is not used on other switches.



## Reset (Managed Switches)

The switch can be reset (power cycle) by pressing the RESET button on the face of the switch for 1-3 seconds.

The switch will be RESET to FACTORY DEFAULT by pressing the RESET button on the face of the switch for 5 seconds.

The switch may also be reset or restored to factory defaults via the switch management interface.



## LED Indicators

### LEDs on DIN rail Mounted Models



Communication LEDs		
<b>ACT/LNK LED</b>	<b>On</b>	Indicates that there is a proper Ethernet connection (Link) between the port and another Ethernet device, but no communications activity is detected.
	<b>Blinking</b>	Indicates that there is a proper Ethernet connection (Link) between the port and another Ethernet device, and that there is communications activity.
	<b>Off</b>	Indicates that there is not a proper Ethernet connection (Link) between the port and another Ethernet device. Make sure the cable has been plugged securely into the ports at both ends.
<b>Speed LED 10/100 Models</b>	<b>On</b>	A 100 Mbps (100BaseT) connection is detected.
	<b>Off</b>	A 10 Mbps (10BaseT) connection is detected.
<b>Speed LED 10/100/1000 Models</b>	<b>On</b>	A 1000 Mbps (1000BaseT) connection is detected
	<b>Off</b>	A 100 or 10 Mbps (100BaseT or 10BaseT) connection is detected



Front Panel LEDs		
<b>RUN *</b>	<b>On</b>	CPU is running abnormally or the switch is starting
	<b>Blinking (1Hz)</b>	CPU is running normally
	<b>Off</b>	CPU is not running
<b>Alarm *</b>	<b>On</b>	System alarm
	<b>Off</b>	No system alarm
<b>PWR1 LED</b>	<b>On</b>	Power 1 connected and operational
	<b>Off</b>	Power 1 no voltage
<b>PWR2 LED</b>	<b>On</b>	Power 2 connected and operational
	<b>Off</b>	Power 2 no voltage
<b>RING *</b>	<b>On</b>	Master (AD-Ring mode) / Root (ADP mode)
	<b>Blinking</b>	Slave (AD-Ring mode) / B-Root (ADP mode)
	<b>Off</b>	No ring mode
<b>PoE**</b>	<b>On</b>	Port is providing power
	<b>Off</b>	Port is not providing power

\* Managed switches only  
\*\* PoE switches only

## LEDs on IP65 Models



IP65 Models Front Panel LEDs		
<b>Power 1 LED</b>	<b>On</b>	Power 1 connected and operational
	<b>Off</b>	Power 1 no voltage
<b>Power 2 LED</b>	<b>On</b>	Power 2 connected and operational
	<b>Off</b>	Power 2 no voltage
<b>Ethernet port connection status LED</b>	<b>On</b>	Ethernet port connected
	<b>Blinking</b>	Ethernet port active
	<b>Off</b>	Ethernet port no connection

## Installation, DIN Rail Mounting

Stride SE2 series switches can be snapped onto a standard 35 mm x 7.5 mm height DIN rail (Standard: CENELEC EN50022) and can be mounted either vertically or horizontally. See **Installation, IP65 Switches Panel Mounting** later in this chapter for mounting IP65 rated switches. Allow 2cm (0.79 in) of clearance between the SE2 switch and other equipment on the DIN rail, side to side and top to bottom.



**NOTE:** Make sure to allow enough room to route your Ethernet copper or fiber optic cables.

### DIN rail installation steps (All Models):

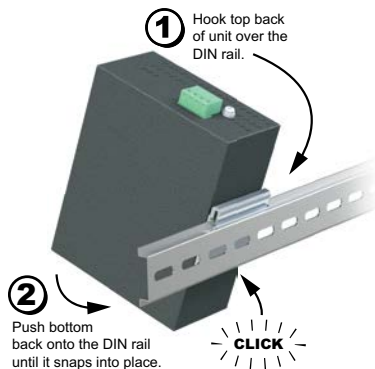

### DIN rail removal steps (Unmanaged Models):

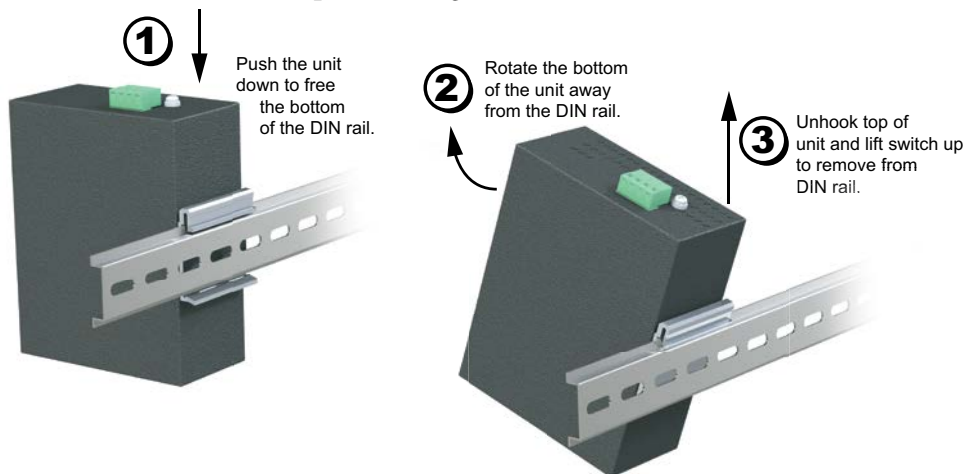

## DIN rail removal steps (Unmanaged Models):

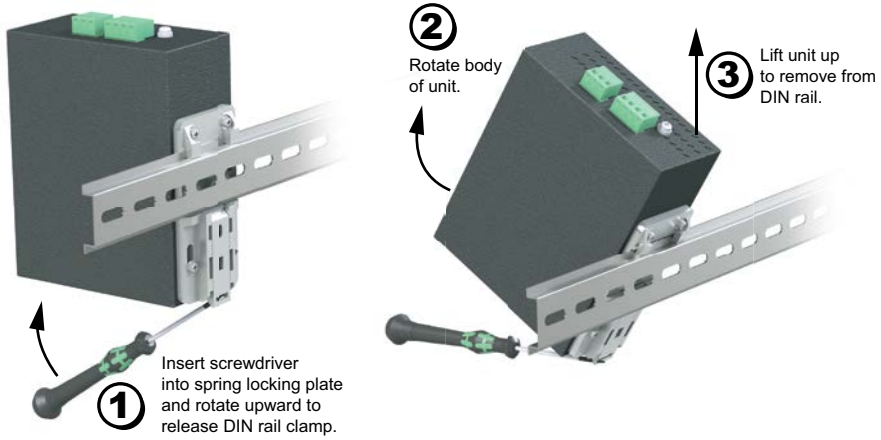

## Installation, Optional Panel Mounting

Stride SE2 Din rail series switches can be panel mounted with the addition of the optional panel mounting brackets SE2-PM1 or SE2-PM3.

- SE2-PM1 is compatible with SSE2-SW5Ux, SE2-SW8U-x, and SE2-MCx
- SE2-PM3 is compatible with SE2-SWPx, SE2-SW8UG-T, SE2-SW10UG-2P-T, SE2-SW16U-T, SE2-SW18U-2G-T and all SE2 managed switches.

### Mounting Instructions

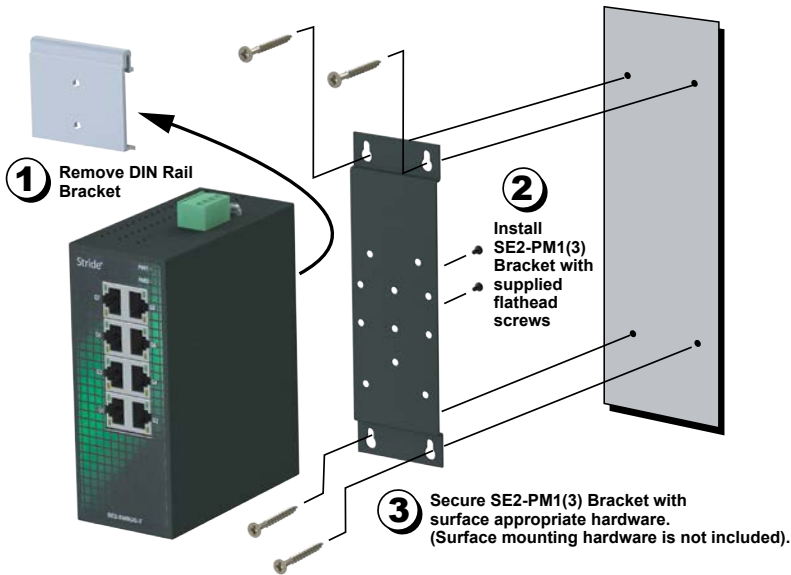

## Installation, IP65 Switches Panel Mounting

IP65 rated switches are designed to be panel mounted vertically or horizontally using the steps below.

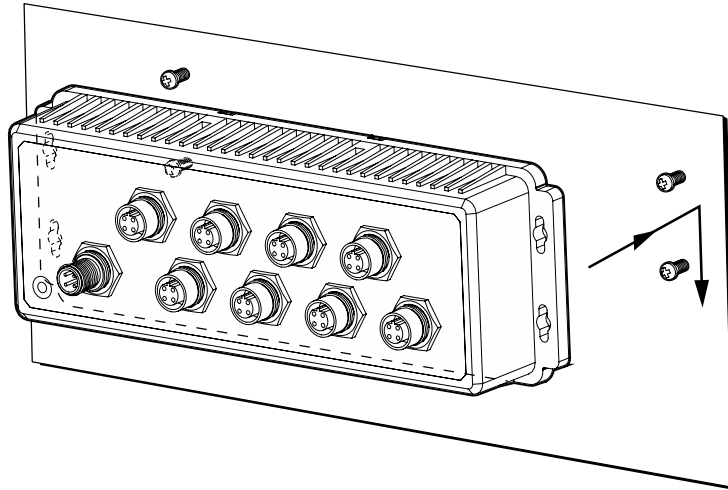

### Panel mounting steps:

- Use the dimensional drawing to locate (4) mounting screws on the panel. Recommended screws are #4-40 pan head.
- Install the screws in the panel leaving a gap of 5mm between the head of the screw and the panel.
- Align the (4) mounting holes with the screw heads and move the switch on to the (4) mounting screws. Allow the switch to slide into position.
- Tighten the four mounting screws.

## Dimensional Drawings



**NOTE:** Allow 20mm (0.79 in) clearance around each switch for proper cooling.

### Dimensions mm / [inches]

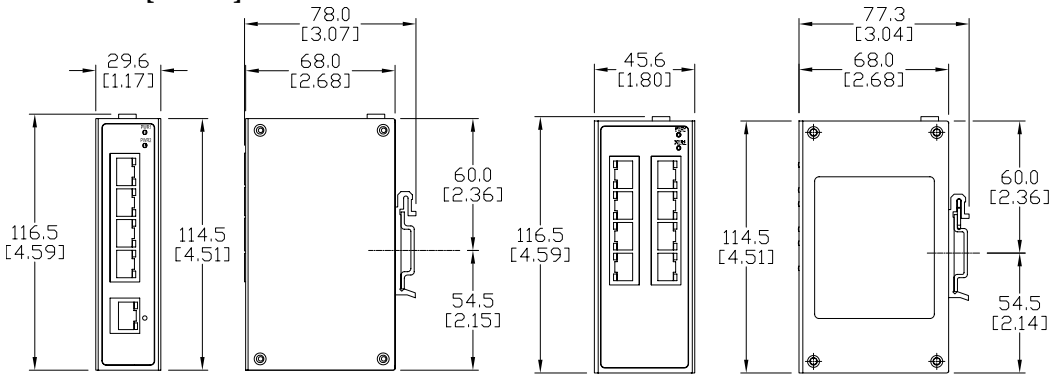

**SE2-MC2U-C1-T, SE2-MC2U-T1-T,  
SE2-SW5U, SE2-SW5U-T, SE2-SW5UG-T,  
SE2-SW5U-1C1-T, SE2-SW5U-1T1-T**

**SE2-SW8U  
SE2-SW8U-T**

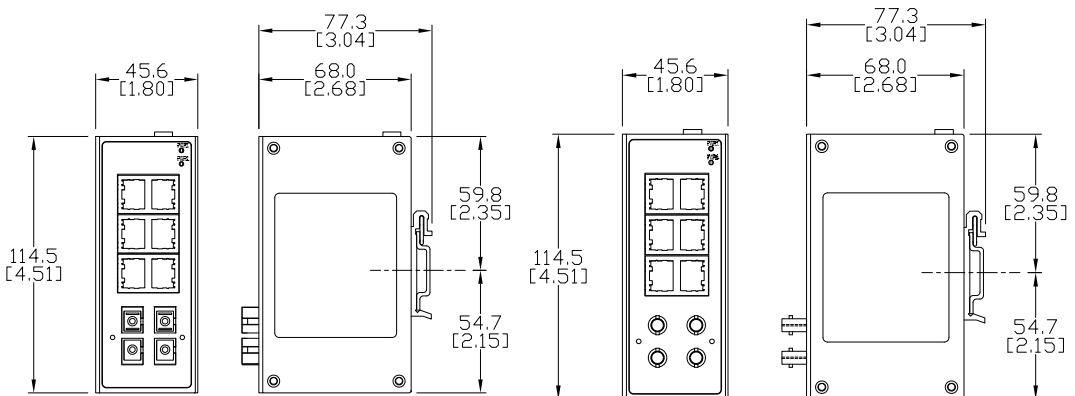

**SE2-SW8U-2C1-T**

**SE2-SW8U-2T1-T**

# Dimensional Drawings (cont'd)



**NOTE:** Allow 20mm (0.79") clearance around each switch for proper cooling.

## Dimensions mm / [inches]

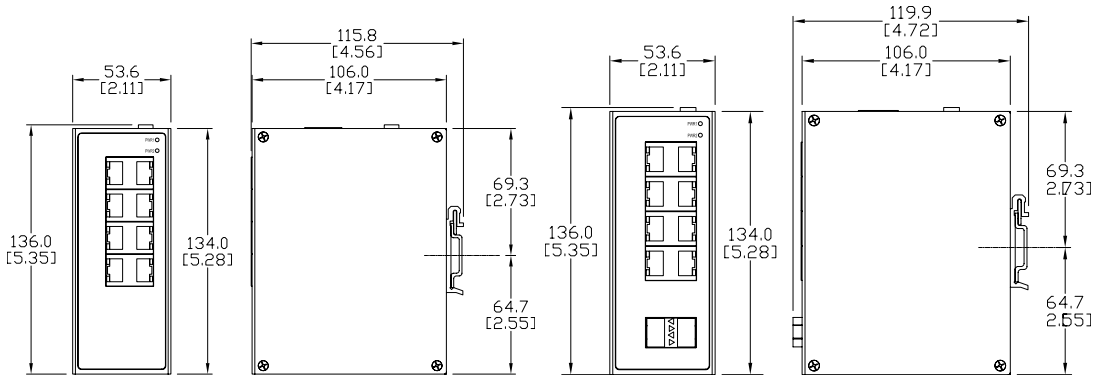

SE2-SW8UG-T

SE2-SW10UG-2P-T

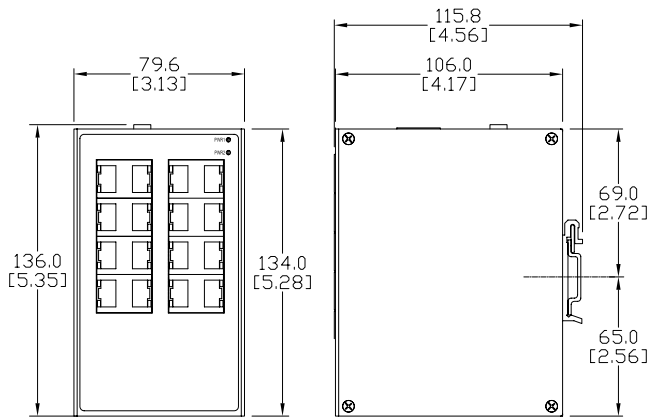

SE2-SW16U-T

## Dimensional Drawings (cont'd)



**NOTE:** Allow 20mm (0.79") clearance around each switch for proper cooling.

**Dimensions**  
mm / [inches]

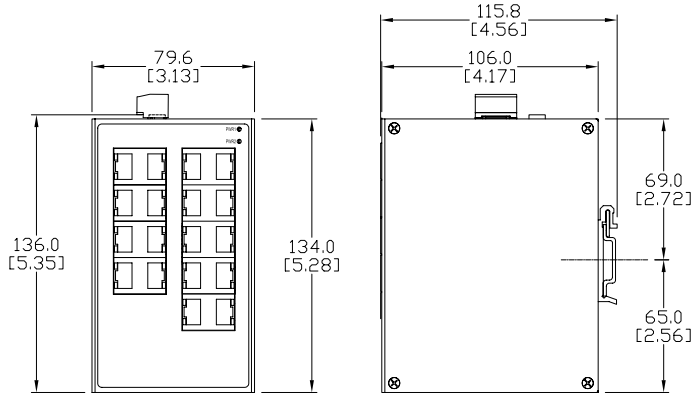

**SE2-SW18U-2G-T**

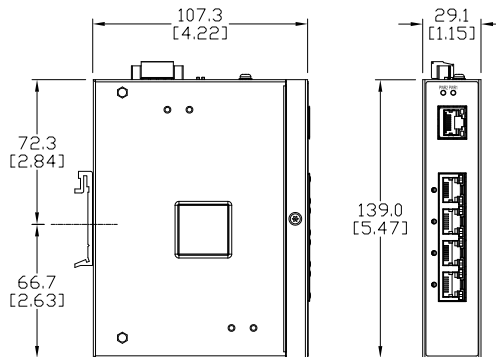

**SE2-SWP5U-T**  
**SE2-SWP5UG-T**

## Dimensional Drawings (cont'd)

Dimensions  
mm / [inches]

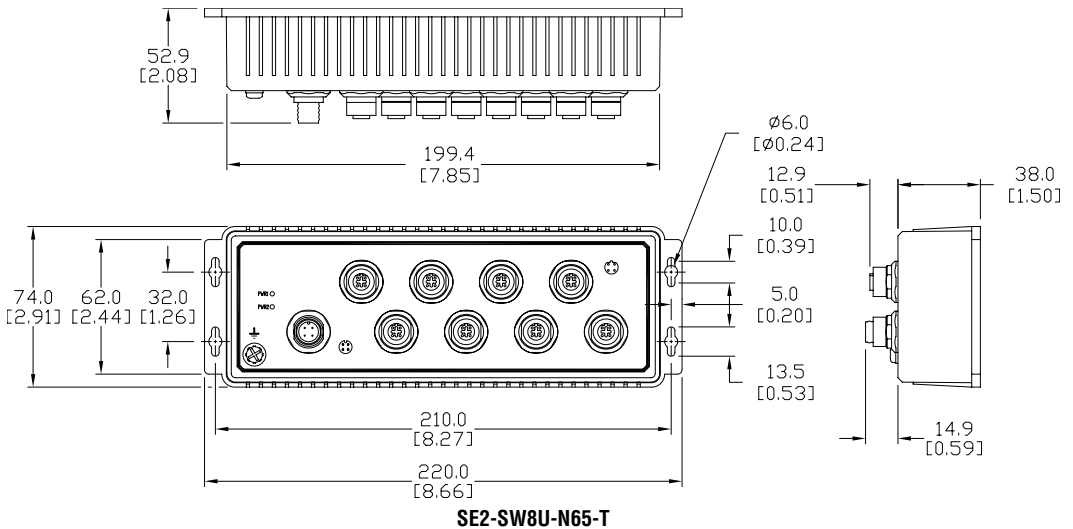
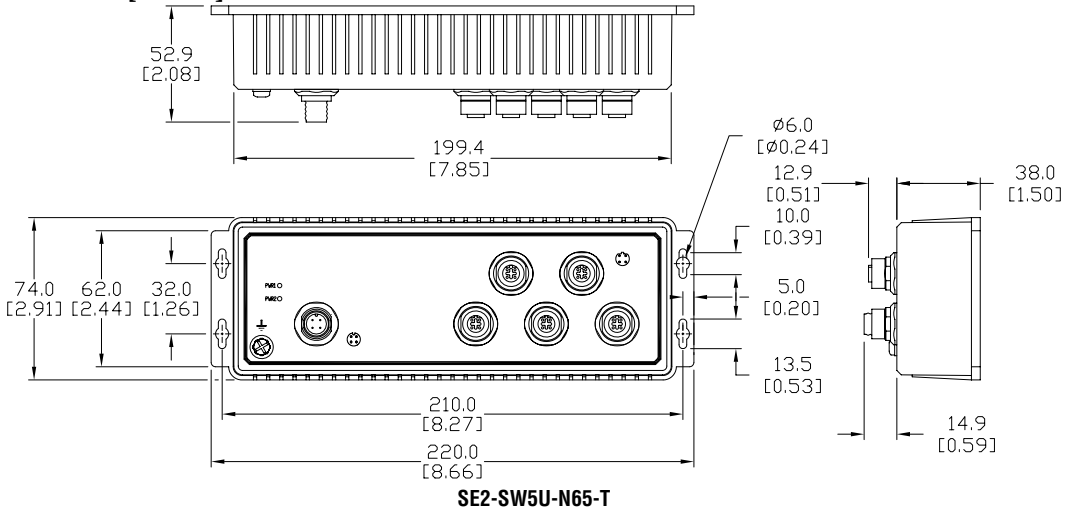

## Dimensional Drawings (cont'd)

### Dimensions

mm / [inches]

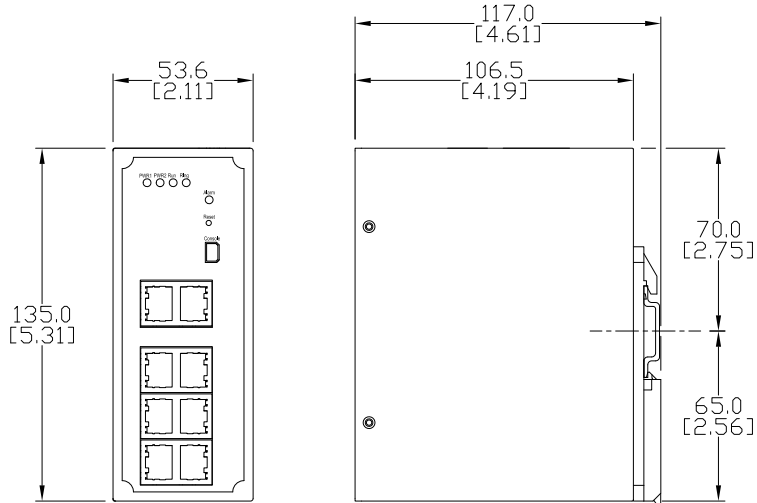

**SE2-SW8M**

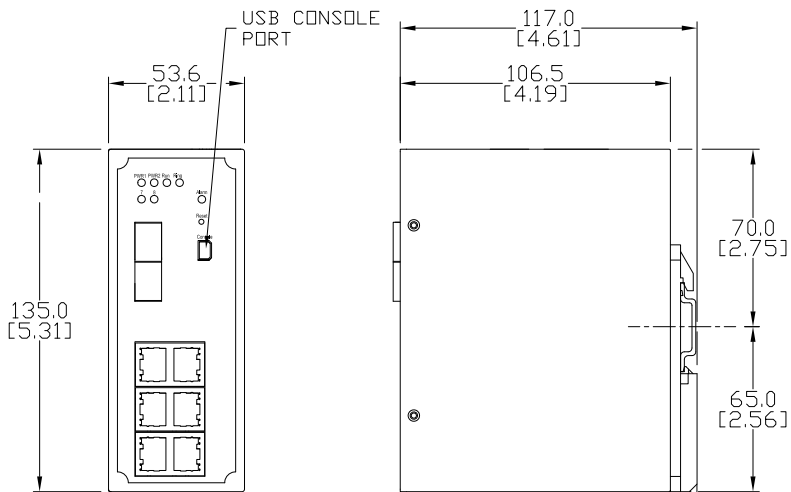

**SE2-SW8M-2P**

## Dimensional Drawings (cont'd)

**Dimensions**  
mm / [inches]

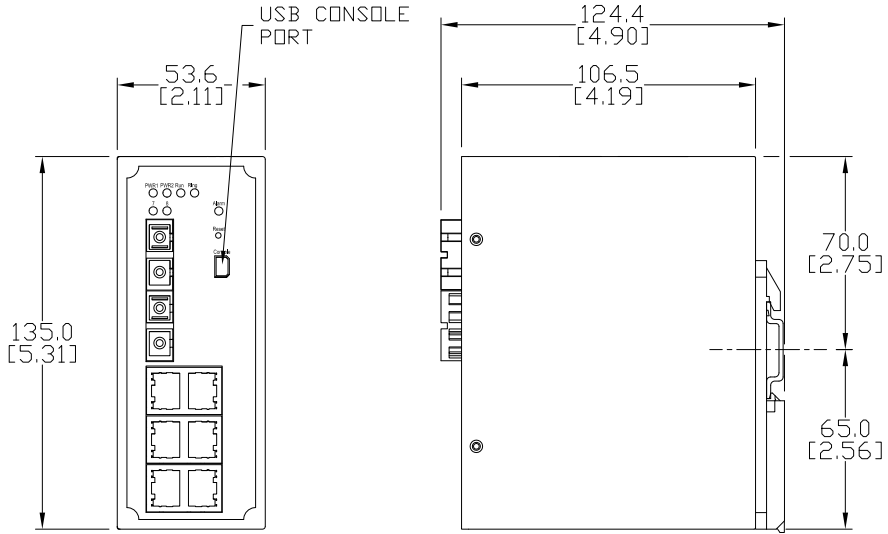

**SE2-SW8M-2C1**

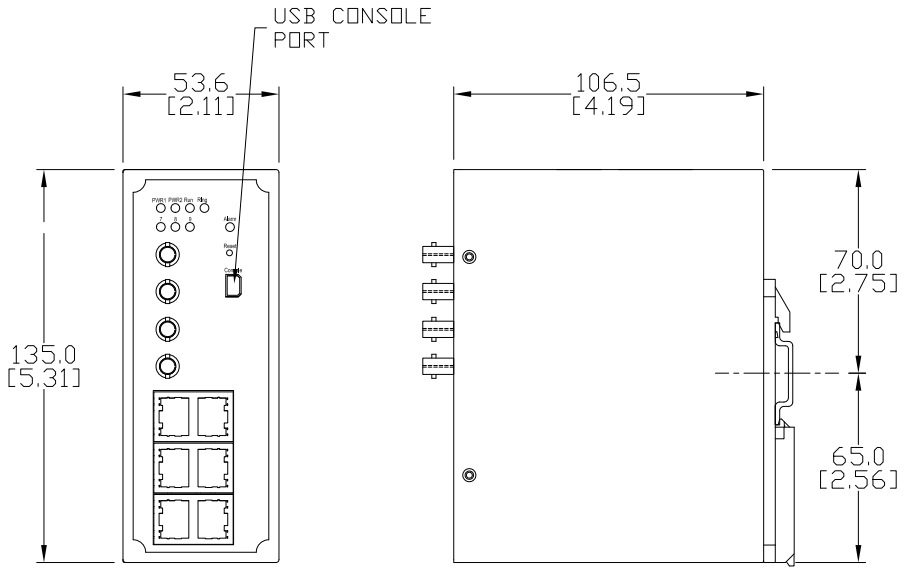

**SE2-SW8M-2T1**

## Dimensional Drawings (cont'd)

### Dimensions

mm / [inches]

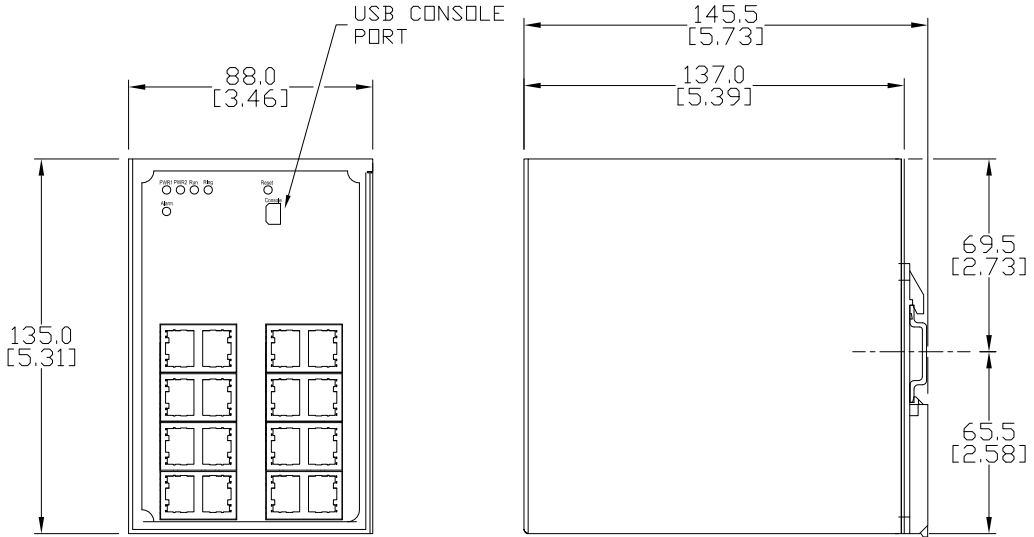

**SE2-SW16M**

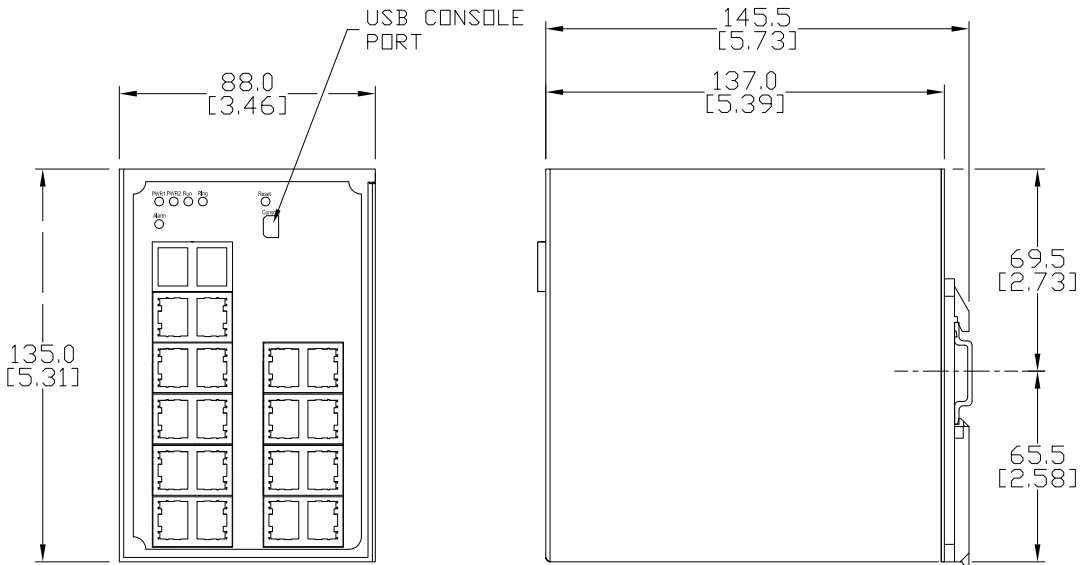

**SE2-SW18MG-2P**

## Dimensional Drawings (cont'd)

### Dimensions for SFP Transceiver Modules

Dimensions  
mm / [inches]

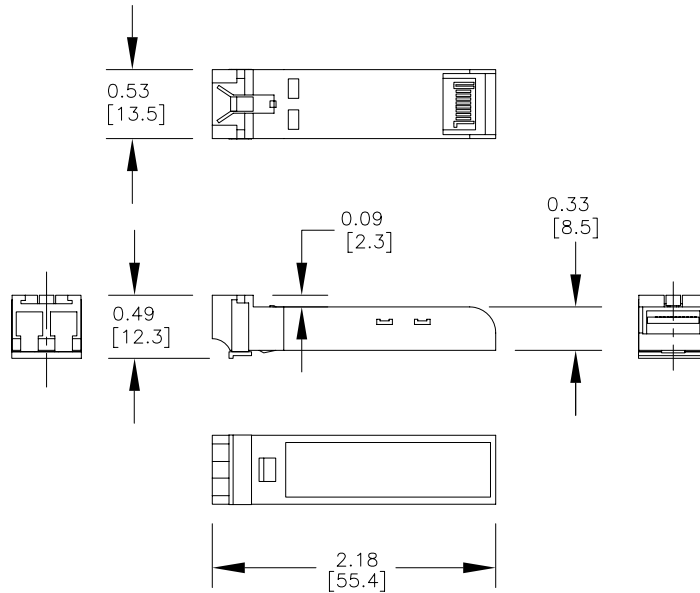

SFP-4K-FMF, SFP-30K-FSF, SFP-500-GMF, SFP-2K-GMF, SFP-10K-GSF and SFP-30K-GSF

## Power Wiring



**WARNING:** Before performing any wiring to these switches make sure...

- The area is currently nonhazardous (especially when working in Class 1, Div 2 or Zone 2 hazardous locations).
- Power is off to the switch
- The screw terminal block is unplugged. This is especially important on the aluminum housed units. Connecting or disconnecting wires to the screw block when it's in place and power is turned on can allow the screwdriver to short the power to the case.

### Unmanaged non-PoE Models (DIN rail mount)

The switch can be powered from the same source that is used to power your other devices. To maintain the UL listing, this must be a Class 2 power supply. 12, 24 or 48 VDC or 24VAC needs to be applied between the P1+ terminal and the P1- terminal as shown below. The chassis screw terminal should be tied to panel or chassis ground. To reduce down time resulting from power loss, the switch can be powered redundantly with a second power supply as shown below. The switch is equipped with reverse power protection, but care should be taken to connect the positive and negative terminals correctly.

A recommended DC power supply is [AutomationDirect.com](http://AutomationDirect.com) part number PSL-24-030.

Power Details	
<b>Power Input</b>	Redundant Input Terminals
<b>Input Voltage</b>	Class 2 Power Supply: 12-48 VDC, 18-30 VAC*
<b>Input Voltage Range</b>	9-60 VDC, 18-30 VAC
<b>Reverse Power Protection</b>	Yes
<b>Wire Size and Torque</b>	24-12 AWG, max wire length 3m (9.84 ft); Wire strip length 7mm; Torque: 4.5-5.0 lb-in (0.51-0.75 N-m)
<b>Power Consumption</b>	Refer to Models tables on previous pages in this chapter.

\* The SE2 series unmanaged switches use a full wave rectifier.

### Redundant DC Power

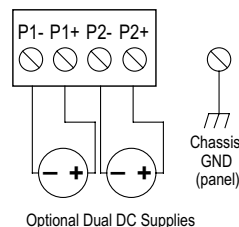

## Unmanaged PoE Switches



**NOTE:** In order to source power (PSE), a PoE switch must be supplied with 48-58 VDC. When supplied with 12-24 VDC, the switch will communicate properly via Ethernet but will not source power by PoE to a connected device (PD).

The switch can be powered from the same source that is used to power your other devices. To maintain the UL listing, this must be a Class 2 power supply. 48 VDC must be applied between the P1+ terminal and the P1- terminal as shown.

The chassis screw terminal should be tied to panel or chassis ground. To reduce down time resulting from power loss, the switch can be powered redundantly with a second power supply as shown below. The switch is equipped with reverse power protection, but care should be taken to connect the positive and negative terminals correctly.

A recommended DC power supply is [AutomationDirect.com](http://AutomationDirect.com) part number PSB48-120S.

Power Details	
<b>Power Input</b>	Redundant Input Terminals Class 2 Power Supply:
<b>Input Voltage</b>	12 or 24VDC for Ethernet communications only, 48-58 VDC for PoE (15.4 W per port) 54-58 VDC for PoE+ (30W per port)
<b>Reverse Power Protection</b>	Yes
<b>Wire Size and Torque</b>	24-16 AWG, max wire length 3m (9.84 ft); Wire strip length 7mm; Torque: 1.77 lb-in (0.20 N·m)
<b>Power Consumption</b>	switch only = 3W
<b>Power Budget</b>	Ensure power supply to the switch is sized adequately to account for powered devices (PD). switch plus PDs = 123 W max
<b>Ground Connection</b>	< 5Ω 18 - 14 AWG

Redundant DC Power

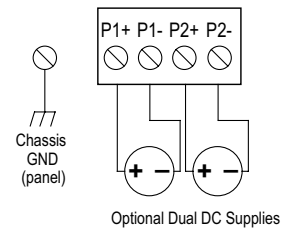

**NOTE:** Although the IEEE 802.3af/at standards require the PD to be insensitive to the polarity of the power supply, care should be taken to confirm that the connected PD is fully compliant to the standard. If the connected PD is sensitive to the power polarity, select an appropriate Ethernet cable, straight through or crossover, to meet the requirements of the connected PD.

### M12 Connector Equipped Models

The switch can be powered from the same source that is used to power your other devices. To maintain the UL listing, this must be a Class 2 power supply. 12, 24 or 48 VDC or 24VAC (the SE2 series unmanaged switches use a full wave rectifier) needs to be applied through an M12 (A coded, female, 4-pin) connector as shown in the chart below. The chassis ground screw located on the front of the switch housing should be tied to panel or chassis ground. To reduce down time resulting from power loss, the switch can be powered redundantly with a second power supply as shown in the chart below. The switch is equipped with reverse power protection, but care should be taken to connect the positive and negative terminals correctly.

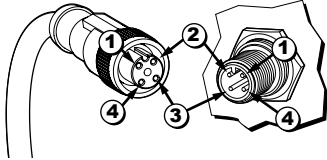

Power Port Pin Definitions			
Pin		DC Wiring	AC Wiring
1	P1 -	PWR1: -	PWR1
2	P1 +	PWR1: +	PWR1
3	P2 -	PWR2: -	PWR2
4	P2 +	PWR2: +	PWR2

## Managed Switches

The switch can be powered from the same DC source that is used to power your other devices. To maintain the UL listing, this must be a Class 2 power supply. A DC voltage in the range of 12 to 24 VDC needs to be applied between the P1+ terminal and the P1- terminal as shown below. The chassis screw terminal should be tied to panel or chassis ground. To reduce down time resulting from power loss, the switch can be powered redundantly with a second power supply as shown below.

A recommended DC power supply is AutomationDirect.com part number PSL-24-030.

**Redundant DC Power**

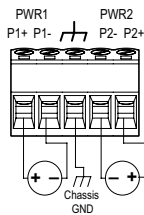

Power Details	
<b>Power Input</b>	Redundant Input Terminals
<b>Input Voltage</b>	Class 2 Power Supply: 12-24 VDC
<b>Input Voltage Range</b>	10.2-27.6 VDC
<b>Reverse Power Protection</b>	Yes
<b>Wire Size and Torque</b>	18-12 AWG, max wire length 3m (9.84 ft); Wire strip length 7mm; Torque: 3.5 lb-in (0.4 N-m)
<b>Power Consumption</b>	Refer to Models tables on previous pages in this chapter

## Communication Ports Wiring

### Overview

The industrial Ethernet switches provide connections to standard Ethernet devices such as PLCs, Ethernet I/O, industrial computers and much more. RJ45 or M12 (for IP65 locations) Ethernet ports or fiber/SFP option ports are available depending on model.

### Ethernet Wiring

Use data-quality (not voice-quality) twisted pair cable rated category 5e (or better) with standard RJ45 or M12 (D coded, male, 4-pin) connectors. Straight-through or crossover Ethernet cable can be used for all devices the switch is connected to because all the ports are capable of auto-mdi/mdix-crossover detection.

The RJ45 Ethernet port connector bodies on these products are metallic and connected to the Chassis GND terminal. Therefore, shielded cables may be used to provide further protection. To prevent ground loops, the cable shield should be tied to the metal connector body at one end of the cable only. Electrical isolation is also provided on the Ethernet ports for increased reliability.

### Duplex Operation

The RJ45 and M12 ports will auto-sense for Full or Half duplex operation.



**NOTE:** M12 caps (part number: ZP-JBH-CAP) must be used on open (disconnected) ports.

## Ethernet Cable Wiring

Straight-thru Cable Wiring	
Pin 1	Pin 1
Pin 2	Pin 2
Pin 3	Pin 3
Pin 4	Pin 4
Pin 5	Pin 5
Pin 6	Pin 6
Pin 7	Pin 7
Pin 8	Pin 8

Cross-over Cable Wiring	
Pin 1	Pin 3
Pin 2	Pin 6
Pin 3	Pin 1
Pin 4	Pin 4
Pin 5	Pin 5
Pin 6	Pin 2
Pin 7	Pin 7
Pin 8	Pin 8



**NOTE:** For reference only. Either cable wiring will work.

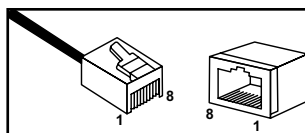

**Ethernet Plug & Connector Pin Positions**

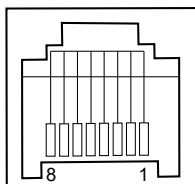

PoE Switch Ethernet Port Pin Definitions			
Pin		Pin	
1	V -	5	TRD2 -
2	V +	6	V -
3	V -	7	TRD3 +
4	TRD2 + (transmit / receive data)	8	TRD3 -

### Cable Distance

The maximum cable length for 10/100/1000BaseT is 100 meters (328 ft.).

### M12 Communication Wiring

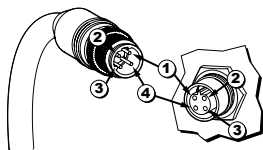

Communication Port Pin Definitions	
Pin	MDI Signal
1	Transmit Data + (TD+)
2	Receive Data + (RD+)
3	Transmit Data - (TD-)
4	Receive Data - (RD-)

## Ethernet Fiber Wiring Guidelines

Some switches include fiber ports, either SC or ST connector, or an SFP option. Refer to the switch specifications for details on the available connection types.

For each fiber port there is a transmit (TX) and receive (RX) signal. When making your fiber optic connections, make sure that the transmit (TX) port of the switch connects to the receive (RX) port of the other device, and the receive (RX) port of the switch connects to the transmit (TX) port of the other device. Use standard fiber optic wiring techniques (not covered by this manual) to make your connections.

It is important to consider the output power and the receiver sensitivity for each end of each fiber connection, especially when the distances that each fiber transceiver in each switch are specified to support differ or when the transceivers (switches) are separated at a distance different than that which the transceivers are specified to support.

It is important to include in your network design an evaluation of the output power and receiver sensitivity based on:

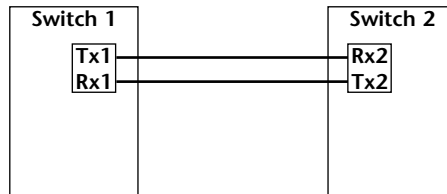

The fiber cable loss (LF) plus attenuator loss (LR) should be greater than the transmit power (TX) minus the receive power (RX).

So,  $LR = TX1 - RX2 - LF$ , for the attenuator (LR) placed at RX2 and

$LR = TX2 - RX1 - LF$ , for the attenuator (LR) placed at RX1.

## Verifying Connectivity

After all Ethernet and/or fiber connections are made, check the LEDs corresponding to the ports that each of the devices are connected to. Ensure that for each port that is in use, the LED is on or blinking. If a port LED is off, go back and check for connectivity problems between that port and the network device connected to that port (see prior section on LEDs).

## Alarm Wiring

Alarm conditions may be configured in the switch, see Chapter 3 for details. When an alarm condition is true, the normally open contact closes and the normally closed contact opens up.

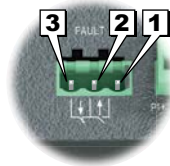

# Technical Specifications

## Unmanaged Models

The following specifications refer to these models.

SE2-MC2U-C1-T	SE2-SW5U	SE2-SW8U	SE2-SW10UG-2P-T
SE2-MC2U-T1-T	SE2-SW5U-T	SE2-SW8U-T	SE2-SW16U-T
	SE2-SW5UG-T	SE2-SW8U-2C1-T	SE2-SW18U-2G-T
	SE2-SW5U-1C1-T	SE2-SW8U-2T1-T	
	SE2-SW5U-1T1-T	SE2-SW8UG-T	

General Specifications	
<b>Operating Mode</b>	Store and forward wire speed switching, non-blocking
<b>Devices Supported</b>	All IEEE 802.3 compliant devices are supported
<b>MAC Addresses</b>	8K for SE2-SWxG-T, SE2-SW16U-T, SE2-SW18U-2G-T 2K
<b>Packet Buffer</b>	1Mbit
<b>Packet Forwarding Rate</b>	0.75 Mpps - SE2-MC2U-x, SE2-SW5U & SE2-SW5U-x 1.2 Mpps - SE2-SW8U-x 7.4 Mpps - SE2-SW5UG-T 14.9 Mpps - SE2-SW8UG-T & SE2-SW10UG-2P-T 5.7 Mpps - SE2-SW16U-T & SE2-SW18U-2G-T
<b>Broadcast Storm Protection*</b>	DIP switch enabled (DIP switch I)
<b>Latency</b>	< 10 µs
<b>Jumbo Frame Support</b>	DIP switch enabled for SE2-SW5UG-T, SE2-SW8UG-T, SE2-SW10UG-2P-T and SE2-SW18U-2G-T only (DIP switch II ON)**
<b>Storage Temperature Range</b>	-40 to +85 °C (-40 to +185 °F)
<b>Humidity (non-condensing)</b>	5 to 95% RH
<b>Environmental Air</b>	No corrosive gases permitted
<b>Vibration, Shock &amp; Freefall</b>	IEC60068-2-6, -27, -32
<b>EMI Emissions</b>	FCC CFR47 Part 15, EN55032/CISPR32, Class A
<b>EMS</b>	IEC61000-4-2 (ESD): +/- 6kV (contact), +/- 8kV (air) IEC61000-4-3 (RS): 10V/m (80MHz ~ 2GHz) IEC61000-4-4 (EFT): Power Port +/- 2kV; Data Port: +/- 1kV IEC61000-4-5 (Surge): Power Port: +/- 1kV/DM, +/- 2kV/CM; Data Port +/- 2kV IEC61000-4-6 (CS): 10V (150kHz ~ 80MHz)
<b>RoHS and WEEE</b>	RoHS (Pb free) and WEEE compliant
<b>Packaging and Protection</b>	Metal case, IP30
<b>Hazardous Locations</b>	ANSI/ISA 12.12.01-2015 & CSA 22.2 No. 213-15 (Class I, Div.2) (file #E200031); UL/cUL 61010-1 and 61010-2-201, Class 1, Div. 2, Groups A, B, C, D, (UL file #E200031) CE
<b>Agency Approvals</b>	
* Broadcast storm threshold value is 2 packets/100ms for 10 Mbps port or 2 packets/10ms for 100 Mbps and 1000 Mbps ports.	
** DIP switch II is unused on the 10/100 models.	

## Unmanaged Models Technical Specifications (cont'd)

Power Details	
<b>Power Input</b>	Redundant Input Terminals
<b>Input Voltage</b>	Class 2 Power Supply: 12-48 VDC, 18-30VAC* 50/60 Hz
<b>Input Voltage Range</b>	9-60 VDC, 18-30 VAC
<b>Reverse Power Protection</b>	Yes
<b>Power Consumption</b>	Refer to Models tables on previous pages in this chapter

\* The SE2 series unmanaged switches use a full wave rectifier.

RJ45 Ports	
<b>Port Type</b>	Shielded RJ45
<b>Ethernet Compliance</b>	IEEE 802.3i, 802.3u, 802.3x for 10/100 Ethernet IEEE 802.3ab, 802.3z for Gigabit Ethernet
<b>Auto-Crossover</b>	Yes, allows you to use straight-through or crossover wired cables
<b>Auto-Sensing Operation</b>	Yes, full and half duplex
<b>Auto-Negotiating Speed</b>	Yes
<b>Flow Control</b>	Automatic
<b>Cable Requirements</b>	Twisted pair (Cat5e or better) (shielded recommended)
<b>Max. Cable Distance</b>	100 meters

SC/ST Fiber Port: (100BaseFX Multimode)	
<b>100BaseFX Ports</b>	2
<b>Fiber Port Connector</b>	ST or SC, by model
<b>Optimal Fiber Cable</b>	50/125 or 62.5/125 $\mu$ m
<b>Center Wavelength</b>	1300 nm
<b>Multimode</b>	Links up to 4 km typ. > Transmitter power (dBm): -21 min, -17 typ, -14 max > Receiver sensitivity (dBm): -34 typ, -31 max
<b>Nominal Max. Distance (full duplex)</b>	4 km
<b>Eye Safety (laser)</b>	IEC 60825-1, Class 1; FDA 21 CFR 1040.10 and 1040.11

SFP (Small Form Factor Pluggable) Ports	
<i>Optional SFP modules sold separately. Use only Gigabit speed SFPs with SE2-SW10UG-2P-T.</i>	
<b>Eye Safety</b>	IEC 60825-1, Class 1; FDA 21 CFR 1040.10 and 1040.11



**NOTE:** Refer to SFP module specifications for details specific to the SFP installed.

## Unmanaged PoE Models

The following specifications refer to these models.

SE2-SWP5U-T  
SE2-SWP5UG-T

General Specifications	
<b>Operating Mode</b>	Store and forward wire speed switching, non-blocking
<b>Devices Supported</b>	All IEEE 802.3 compliant devices are supported
<b>MAC Addresses</b>	2K
<b>Packet Buffer</b>	1Mbit
<b>Packet Forwarding Rate</b>	1.5 Mpps
<b>Broadcast Storm Protection*</b>	DIP switch enabled (DIP switch 1)
<b>Latency</b>	< 15 μs
<b>Jumbo Frame</b>	9K
<b>Storage Temperature Range</b>	-40 to +85 °C (-40 to +185 °F)
<b>Humidity (non-condensing)</b>	5 to 95% RH
<b>Environmental Air</b>	No corrosive gases permitted
<b>Vibration, Shock &amp; Freefall</b>	IEC60068-2-6, -27, -32
<b>EMI Emissions</b>	FCC CFR47 Part 15, EN55032/CISPR32, Class A
<b>EMS</b>	IEC61000-4-2 (ESD): +/- 6kV (contact), +/- 8kV (air) IEC61000-4-3 (RS): 10V/m (80MHz ~ 2GHz) IEC61000-4-4 (EFT): Power Port +/- 2kV; Data Port: +/- 1kV IEC61000-4-5 (Surge): Power Port: +/- 1kV/DM, +/- 2kV/CM; Data Port +/- 2kV IEC61000-4-6 (CS): 10V (150kHz ~ 80MHz)
<b>RoHS and WEEE</b>	RoHS (Pb free) and WEEE compliant
<b>Packaging and Protection</b>	Metal case, IP30
<b>Hazardous Locations</b>	ANSI/ISA 12.12.01-2015 & CSA 22.2 No. 213-15 (Class I, Div.2) (file #E200031);
<b>Agency Approvals</b>	UL/cUL 61010-1 and 61010-2-201 Class 1, Div. 2, Groups A, B, C, D, (UL file #E200031) CE
* Broadcast storm threshold value is 2 packets/100ms for 10 Mbps port or 2 packets/10ms for 100 Mbps and 1000 Mbps ports. DIP switch 11 is unused.	

## Unmanaged PoE Models Technical Specifications (cont'd)

Power Details	
<b>Power Input</b>	Redundant Input Terminals
	Class 2 Power Supply
<b>Input Voltage</b>	12 or 24VDC for Ethernet communications only,
	48-58 VDC for PoE (15.4 W per port)
	54-58 VDC for PoE+ (30W per port)
<b>Reverse Power Protection</b>	Yes
<b>Wire Size and Torque</b>	24-16 AWG, max wire length 3m (9.84 ft);
	Wire strip length 7mm;
	Torque: 1.77 lb-in (0.2 N-m)
<b>Wire Temperature</b>	85°C (185°F) Max.
<b>Power Consumption</b>	switch only = 3W
<b>Power Budget</b>	Ensure power supply to the switch is sized adequately to account for powered devices (PD).
	switch plus PDs = 123 W max
<b>Ground Connection</b>	< 5Ω
	18 - 14 AWG

RJ45 Ports	
<b>Port Type</b>	Shielded RJ45
<b>Ethernet Compliance</b>	IEEE 802.3i, 802.3u, 802.3x for 10/100 Ethernet IEEE 802.3ab, 802.3z for Gigabit Ethernet IEEE 802.3af or 802.3at for PoE
<b>Auto-Crossover</b>	Yes, allows you to use straight-through or crossover wired cables
<b>Auto-Sensing Operation</b>	Yes, full and half duplex
<b>Auto-Negotiating Speed</b>	Yes
<b>Flow Control</b>	Automatic
<b>Cable Requirements</b>	Twisted pair (Cat5e or better) (shielded recommended)
<b>Max. Cable Distance</b>	100 meters

PoE Details	
<b>Max Power per Port</b>	30W at 48-58 VDC
	720mA
	V+ pins 1, 2
	V- pins 3, 6
<b>Power Input</b>	54-58 VDC for PoE+
	48-58 VDC for PoE
<b>PD (Powered Device) Detection</b>	Yes - the switch port will detect the presence of a PoE enabled device before sending power. If a non-PoE device is detected, power will not be sourced on that port but Ethernet connections will be permitted.
<b>PoE Overload Protection</b>	Yes
<b>Reverse Protection</b>	Yes
<b>Redundancy Protection</b>	Yes

## Unmanaged IP65 Rated Models

The following specifications refer to these models.

SE-SW5U-N65-T

SE-SW8U-N65-T

General Specifications	
<b>Operating Mode</b>	Store and forward wire speed switching, non-blocking
<b>Devices Supported</b>	All IEEE 802.3 compliant devices are supported
<b>MAC Addresses</b>	2K
<b>Packet Buffer</b>	1Mbit
<b>Packet Forwarding Rate</b>	1.2 Mpps
<b>Latency</b>	< 10 μs
<b>Operating Temperature Range</b>	-40 to +75°C (-40 to +167°F)
<b>Storage Temperature Range</b>	-40 to +85°C (-40 to +185°F)
<b>Humidity (non-condensing)</b>	5 to 95% RH
<b>Pollution Degree</b>	2
<b>Vibration and Shock</b>	IEC60068-2-6, -27, -32
<b>Freefall</b>	IEC60068-2-32
<b>Safety</b>	EN60950-1
<b>EMI Emissions</b>	FCC CFR47 Part 15, EN55032/CISPR32, Class A
<b>EMS</b>	IEC61000-4-2 (ESD): ± 6kV (contact), ± 8kV (air) IEC61000-4-3 (RS): 20V/m (80MHz ~ 2 GHz) IEC61000-4-4 (EFT): Power Port ± 2kV; Data Port: ± 2kV IEC61000-4-5 (Surge): Power Port: ± 1kV/DM, ± 2kV/CM IEC61000-4-6 (CS): 10V (150 kHz ~ 80 MHz) IEC61000-4-8 (Power frequency magnetic field): 50 Hz 100A/m IEC61000-4-9 (Pulsed magnetic field): 300A/m IEC61000-4-29 (Voltage short interruptions): 10ms 100%
<b>RoHS and WEEE</b>	RoHS (Pb free) and WEEE compliant
<b>Packaging and Protection</b>	Metal Case, IP65
<b>Agency Approvals</b>	UL/cUL 61010-1 and UL/cUL 61010-2-201 (UL file #E157382), CE, EN50155, EN50121

Power Details	
<b>Power Input</b>	Redundant Input M12 connector
<b>Input Voltage</b>	Class 2 Power Supply: 12-48 VDC, 18-30VAC* 50/60 Hz
<b>Input Voltage Range</b>	9-60 VDC, 18-30 VAC
<b>Power Input Ports</b>	M12, male, A-coding, 4-pin
<b>Reverse Power Protection</b>	Yes

\* The SE2 series unmanaged switches use a full wave rectifier.

## Unmanaged IP65 Rated Models (cont'd)

M12 Ethernet Ports	
<b>10/100BaseT ports</b>	M12, female, D-coding, 4-pin
<b>Ethernet Compliance</b>	IEEE 802.3i, 802.3u, 802.3x
<b>Auto-Crossover</b>	Yes, allows you to use straight-through or crossover wired cables
<b>Auto-Sensing Operation</b>	Yes, full and half duplex
<b>Auto-Negotiating Speed</b>	Yes
<b>Flow Control</b>	Automatic
<b>Cable Requirements</b>	Twisted pair (Cat5 or better) (shielded recommended)
<b>Max. Cable Distance</b>	100 meters
<i>M12 caps (ZP-JBH-CAP) need to be used on open (disconnect) ports.</i>	

## Managed Models

The following specifications refer to these models.

SE2-SW8M	SE2-SW16M
SE2-SW8M-2C1	SE2-SW18MG-2P
SE2-SW8M-2T1	
SE2-SW8M-2P	

General Specifications	
<b>Operating Mode</b>	Store and forward wire speed switching, non-blocking
<b>Devices Supported</b>	All IEEE 802.3 compliant devices are supported
<b>MAC Addresses</b>	8K 16K for SE2-SW8M-2P
<b>Ethernet Protocols Supported</b>	SNMP v1 / v2 / v3, RMON, DHCP, SNTP, TFTP, STP, RSTP, QoS / DS, IGMPv1 / v2, VLAN (tag and port based), HTTP, HTTPS (SSL and TLS), Telnet, SSH and more
<b>Industrial Protocols Supported</b>	Modbus TCP, EtherNet/IP, PROFINET, Foundation Fieldbus HSE and others
<b>Packet Forwarding Rate</b>	1.4 Mpps – SE2-SW8M 1.4 Mpps–SE2-SW8M-2C1 1.4 Mpps–SE2-SW8M-2T1 5.5 Mpps–SE2-SW8M-2P 5.4 Mpps–SE2-SW16M 5.4 Mpps–SE2-SW18MG-2P
<b>Latency</b>	< 10 $\mu$ s
<b>Operating Temperature Range</b>	-40 to +75°C (-40 to +167°F)
<b>Storage Temperature Range</b>	-40 to +85°C (-40 to +185°F)
<b>Humidity (non-condensing)</b>	5 to 95% RH
<b>Environmental Air</b>	No corrosive gases permitted
<b>Vibration, Shock &amp; Freefall</b>	IEC60068-2-6, -27, -32
<b>EMI Emissions</b>	FCC CFR47 Part 15, EN55032/CISPR32, Class A
<b>EMS</b>	IEC61000-4-2 (ESD): $\pm$ 8kV (contact), $\pm$ 15kV (air) IEC61000-4-3 (RS): 10V/m (80MHz ~ 2GHz) IEC61000-4-4 (EFT): Power Port $\pm$ 4kV; Data Port: $\pm$ 2kV IEC61000-4-5 (Surge): Power Port: $\pm$ 2kV/DM, $\pm$ 4kV/CM; Data Port $\pm$ 2kV IEC61000-4-6 (CS): 10V (150kHz ~ 80MHz)
<b>Hazardous Locations</b>	ANSI/ISA 12.12.01-2015 & CSA 22.2 No. 213-15 (Class I, Div.2) (file #E200031);
<b>RoHS and WEEE</b>	RoHS (Pb free) and WEEE compliant
<b>Packaging and Protection</b>	Metal case, IP40
<b>Agency Approvals</b>	UL/cUL 508, CE

## Managed Models (cont'd)

Power Details	
<b>Power Input</b>	Redundant Input Terminals
<b>Input Voltage</b>	Class 2 Power Supply: 12-24 VDC
<b>Input Voltage Range</b>	10.2-27.6 VDC
<b>Reverse Power Protection</b>	Yes
<b>Wire Size and Torque</b>	18-12 AWG, max wire length 3m (9.84 ft); Wire strip length 7mm; Torque: 3.5 lb-in (0.4 N-m)
<b>Power Consumption</b>	Refer to Models table on previous pages in this chapter

RJ45 Ports	
<b>Port Type</b>	Shielded RJ45
<b>Ethernet Compliance</b>	IEEE 802.3i, 802.3u, 802.3x for 10/100 Ethernet IEEE 802.3ab, 802.3z for Gigabit Ethernet
<b>Auto-Crossover</b>	Yes, allows you to use straight-through or crossover wired cables
<b>Auto-Sensing Operation</b>	Yes, full and half duplex
<b>Auto-Negotiating Speed</b>	Yes
<b>Flow Control</b>	Automatic
<b>Cable Requirements</b>	Twisted pair (Cat5e or better) (shielded recommended)
<b>Max. Cable Distance</b>	100 meters

SFP Ports	
SFP (pluggable) ports accept Mini-GBIC (SFP) transceivers with a speed of 1000Mbps or 100Mbps	
See SFP datasheet for optional fiber transceiver specification	

SC or ST Fiber Port: (100BaseFX multimode)	
<b>100BaseFX Ports</b>	2
<b>Fiber Port Connector</b>	ST or SC, by model
<b>Optimal Fiber Cable</b>	50/125 or 62.5/125 $\mu$ m
<b>Center Wavelength</b>	1300 nm
<b>Multimode</b>	Links up to 4 km typ. > Transmitter power (dBm): -21 min, -17 typ, -14 max > Receiver sensitivity (dBm): -34 typ, -31 max
<b>Nominal Max. Distance (full duplex)</b>	4 km
<b>Eye Safety (laser)</b>	IEC 60825-1, Class 1; FDA 21 CFR 1040.10 and 1040.11

