



**Manual Number: P1-USER-M**

## ⚡ WARNING ⚡

Thank you for purchasing automation equipment from **Automationdirect.com®**, doing business as, **AutomationDirect**. We want your new automation equipment to operate safely. Anyone who installs or uses this equipment should read this publication (and any other relevant publications) before installing or operating the equipment.

To minimize the risk of potential safety problems, you should follow all applicable local and national codes that regulate the installation and operation of your equipment. These codes vary from area to area and usually change with time. It is your responsibility to determine which codes should be followed, and to verify that the equipment, installation, and operation is in compliance with the latest revision of these codes.

At a minimum, you should follow all applicable sections of the National Fire Code, National Electrical Code, and the codes of the National Electrical Manufacturer's Association (NEMA). There may be local regulatory or government offices that can also help determine which codes and standards are necessary for safe installation and operation.

Equipment damage or serious injury to personnel can result from the failure to follow all applicable codes and standards. We do not guarantee the products described in this publication are suitable for your particular application, nor do we assume any responsibility for your product design, installation, or operation.

Our products are not fault-tolerant and are not designed, manufactured or intended for use or resale as on-line control equipment in hazardous environments requiring fail-safe performance, such as in the operation of nuclear facilities, aircraft navigation or communication systems, air traffic control, direct life support machines, or weapons systems, in which the failure of the product could lead directly to death, personal injury, or severe physical or environmental damage ("High Risk Activities"). **AutomationDirect** specifically disclaims any expressed or implied warranty of fitness for High Risk Activities.

For additional warranty and safety information, see the Terms and Conditions section of our catalog. If you have any questions concerning the installation or operation of this equipment, or if you need additional information, please call us at **770-844-4200**.

This publication is based on information that was available at the time it was printed. At **AutomationDirect** we constantly strive to improve our products and services, so we reserve the right to make changes to the products and/or publications at any time without notice and without any obligation. This publication may also discuss features that may not be available in certain revisions of the product.

## Trademarks

This publication may contain references to products produced and/or offered by other companies. The product and company names may be trademarked and are the sole property of their respective owners. AutomationDirect disclaims any proprietary interest in the marks and names of others.

**Copyright 2026, Automationdirect.com® Incorporated  
All Rights Reserved**

No part of this manual shall be copied, reproduced, or transmitted in any way without the prior, written consent of **Automationdirect.com®** Incorporated. AutomationDirect retains the exclusive rights to all information included in this document.

## ⚡ ADVERTENCIA ⚡

Gracias por comprar equipo de automatización de **Automationdirect.com®**. Deseamos que su nuevo equipo de automatización opere de manera segura. Cualquier persona que instale o use este equipo debe leer esta publicación (y cualquier otra publicación pertinente) antes de instalar u operar el equipo.

Para reducir al mínimo el riesgo debido a problemas de seguridad, debe seguir todos los códigos de seguridad locales o nacionales aplicables que regulan la instalación y operación de su equipo. Estos códigos varían de área en área y usualmente cambian con el tiempo. Es su responsabilidad determinar cuales códigos deben ser seguidos y verificar que el equipo, instalación y operación estén en cumplimiento con la revisión más reciente de estos códigos.

Como mínimo, debe seguir las secciones aplicables del Código Nacional de Incendio, Código Nacional Eléctrico, y los códigos de (NEMA) la Asociación Nacional de Fabricantes Eléctricos de USA. Puede haber oficinas de normas locales o del gobierno que pueden ayudar a determinar cuales códigos y normas son necesarios para una instalación y operación segura.

Si no se siguen todos los códigos y normas aplicables, puede resultar en daños al equipo o lesiones serias a personas. No garantizamos los productos descritos en esta publicación para ser adecuados para su aplicación en particular, ni asumimos ninguna responsabilidad por el diseño de su producto, la instalación u operación.

Nuestros productos no son tolerantes a fallas y no han sido diseñados, fabricados o intencionados para uso o reventa como equipo de control en línea en ambientes peligrosos que requieren una ejecución sin fallas, tales como operación en instalaciones nucleares, sistemas de navegación aérea, o de comunicación, control de tráfico aéreo, máquinas de soporte de vida o sistemas de armamentos en las cuales la falla del producto puede resultar directamente en muerte, heridas personales, o daños físicos o ambientales severos ("Actividades de Alto Riesgo"). **Automationdirect.com** específicamente rechaza cualquier garantía ya sea expresada o implicada para actividades de alto riesgo.

Para información adicional acerca de garantía e información de seguridad, vea la sección de Términos y Condiciones de nuestro catálogo. Si tiene alguna pregunta sobre instalación u operación de este equipo, o si necesita información adicional, por favor llámenos al número **770-844-4200** en Estados Unidos.

Esta publicación está basada en la información disponible al momento de impresión. En **Automationdirect.com** nos esforzamos constantemente para mejorar nuestros productos y servicios, así que nos reservamos el derecho de hacer cambios al producto y/o a las publicaciones en cualquier momento sin notificación y sin ninguna obligación. Esta publicación también puede discutir características que no estén disponibles en ciertas revisiones del producto.

## Marcas Registradas

Esta publicación puede contener referencias a productos producidos y/u ofrecidos por otras compañías. Los nombres de las compañías y productos pueden tener marcas registradas y son propiedad única de sus respectivos dueños. **Automationdirect.com**, renuncia cualquier interés propietario en las marcas y nombres de otros.

**Propiedad Literaria 2026, Automationdirect.com® Incorporated**  
**Todos los derechos reservados**

No se permite copiar, reproducir, o transmitir de ninguna forma ninguna parte de este manual sin previo consentimiento por escrito de **Automationdirect.com® Incorporated**. **Automationdirect.com** retiene los derechos exclusivos a toda la información incluida en este documento. Los usuarios de este equipo pueden copiar este documento solamente para instalar, configurar y mantener el equipo correspondiente. También las instituciones de enseñanza pueden usar este manual para propósitos educativos.

## ⚡ AVERTISSEMENT ⚡

Nous vous remercions d'avoir acheté l'équipement d'automatisation de **AutomationDirect.com®**, en faisant des affaires comme, AutomationDirect. Nous tenons à ce que votre nouvel équipement d'automatisation fonctionne en toute sécurité. Toute personne qui installe ou utilise cet équipement doit lire la présente publication (et toutes les autres publications pertinentes) avant de l'installer ou de l'utiliser.

Afin de réduire au minimum le risque d'éventuels problèmes de sécurité, vous devez respecter tous les codes locaux et nationaux applicables régissant l'installation et le fonctionnement de votre équipement. Ces codes diffèrent d'une région à l'autre et, habituellement, évoluent au fil du temps. Il vous incombe de déterminer les codes à respecter et de vous assurer que l'équipement, l'installation et le fonctionnement sont conformes aux exigences de la version la plus récente de ces codes.

Vous devez, à tout le moins, respecter toutes les sections applicables du Code national de prévention des incendies, du Code national de l'électricité et des codes de la National Electrical Manufacturer's Association (NEMA). Des organismes de réglementation ou des services gouvernementaux locaux peuvent également vous aider à déterminer les codes ainsi que les normes à respecter pour assurer une installation et un fonctionnement sûrs.

L'omission de respecter la totalité des codes et des normes applicables peut entraîner des dommages à l'équipement ou causer de graves blessures au personnel. Nous ne garantissons pas que les produits décrits dans cette publication conviennent à votre application particulière et nous n'assumons aucune responsabilité à l'égard de la conception, de l'installation ou du fonctionnement de votre produit.

Nos produits ne sont pas insensibles aux défaillances et ne sont ni conçus ni fabriqués pour l'utilisation ou la revente en tant qu'équipement de commande en ligne dans des environnements dangereux nécessitant une sécurité absolue, par exemple, l'exploitation d'installations nucléaires, les systèmes de navigation aérienne ou de communication, le contrôle de la circulation aérienne, les équipements de survie ou les systèmes d'armes, pour lesquels la défaillance du produit peut provoquer la mort, des blessures corporelles ou de graves dommages matériels ou environnementaux («activités à risque élevé»). La société **AutomationDirect** nie toute garantie expresse ou implicite d'aptitude à l'emploi en ce qui a trait aux activités à risque élevé.

Pour des renseignements additionnels touchant la garantie et la sécurité, veuillez consulter la section Modalités et conditions de notre documentation. Si vous avez des questions au sujet de l'installation ou du fonctionnement de cet équipement, ou encore si vous avez besoin de renseignements supplémentaires, n'hésitez pas à nous téléphoner au **770-844-4200**.

Cette publication s'appuie sur l'information qui était disponible au moment de l'impression. À la société **AutomationDirect**, nous nous efforçons constamment d'améliorer nos produits et services. C'est pourquoi nous nous réservons le droit d'apporter des modifications aux produits ou aux publications en tout temps, sans préavis ni quelque obligation que ce soit. La présente publication peut aussi porter sur des caractéristiques susceptibles de ne pas être offertes dans certaines versions révisées du produit.

## Marques de commerce

La présente publication peut contenir des références à des produits fabriqués ou offerts par d'autres entreprises. Les désignations des produits et des entreprises peuvent être des marques de commerce et appartiennent exclusivement à leurs propriétaires respectifs. AutomationDirect nie tout intérêt dans les autres marques et désignations.

Copyright 2026, **AutomationDirect.com®** Incorporated  
Tous droits réservés

Nulle partie de ce manuel ne doit être copiée, reproduite ou transmise de quelque façon que ce soit sans le consentement préalable écrit de la société **AutomationDirect.com®** Incorporated. AutomationDirect conserve les droits exclusifs à l'égard de tous les renseignements contenus dans le présent document.

# Productivity®1000 User Manual



**Please include the Manual Number and the Manual Issue, both shown below, when communicating with Technical Support regarding this publication.**

**Manual Number: P1-USER-M**

**Issue: 2nd Ed. Rev. N**

**Issue Date: 01/28/26**

| Publication History |          |  |
|---------------------|----------|--|
| Issue               | Date     | Description of Changes   |
| 1st Edition         | 11/17    | Original   |
| 1st Edition, Rev. A | 3/18     | Updated Specification tables and formatting.   |
| 1st Edition, Rev. B | 9/18     | Added 10 new expansion modules.  |
| 1st Edition, Rev. C | 6/19     | Added P1-550, Power supplies P1-01DC & P1-02AC, 7 new expansion modules.   |
| 1st Edition, Rev. D | 8/19     | Updated Logo and registered trademark symbol for Productivity®1000   |
| 1st Edition, Rev. E | 01/20    | Updated Battery installation procedure for P1-540, P1-550 page 2-14, 2-22 & 7-3.   |
| 1st Edition, Rev. F | 02/20    | Added Appendix C for network security considerations.  |
| 1st Edition, Rev. G | 03/20    | Revised wiring schematic page 3-59 for P1-4ADL2DAL   |
| 1st Edition, Rev. H | 03/10/20 | Revised Table page 2-66 for P1-16TR module   |
| 1st Edition, Rev. I | 03/18/20 | Added note on page 1-12 and revised from 8 to 15 modules page 5-6  |
| 1st Edition, Rev. J | 04/20    | Updated formatting.  |
| 1st Edition, Rev. K | 05/20    | Revised Chapter 4 P1-02HSC description   |
| 1st Edition, Rev. L | 07/20    | Revised P1-4ADL2DAL-2 Specification Input Stability to $\pm 0.03\%$ of range   |
| 1st Edition, Rev. M | 08/21    | Added P1-RX module and references for PS-AMC modules   |
| 1st Edition, Rev. N | 09/21    | Updated P1-15TD2 module general specification table.   |
| 1st Edition, Rev. O | 11/21    | Updated remote I/O bases layout graphic heading text (2-31).   |
| 1st Edition, Rev. P | 12/21    | Added software/firmware version note to applicable modules. Revised CPU battery text.  |
| 1st Edition, Rev. Q | 12/27/21 | Added clarifying notes for upper and lower range error limits of respective P1-08ADL-1, P1-04ADL-1, and P1-04ADL2DAL-1 hardware setup dialog boxes in Chapter 3. |

# Productivity®1000 User Manual

| Publication History |            |   |
|---------------------|------------|---|
| Issue               | Date       | Description of Changes  |
| 1st Edition, Rev. R | 3/11/22    | Updated P1-RX specifications.   |
| 1st Edition, Rev. S | 3/22/22    | Updated P1-04AD, P1-04ADL-1, and P1-4ADL2DAL-1 general specification tables.  |
| 2nd Edition         | 10/22      | Revised manual formatting. Updated P1-04HTM spec tables.  |
| 2nd Edition, Rev. A | 01/2023    | Updated P1-04ADL-2, P1-08ADL-2, and P1-4ADL4DAL-2 specification tables.   |
| 2nd Edition, Rev. B | 04/2023    | Added P1-04AD-1 and P1-04AD-2 modules.  |
| 2nd Edition, Rev. C | 11/2023    | Added P1-08ND-TTL and P1-08TD-TTL modules.  |
| 2nd Edition, Rev. D | 03/2024    | Updated P1-15CDD1 data tables and wiring schematics.  |
| 2nd Edition, Rev. E | 05/2024    | Added P1-04TRS module and general updates.  |
| 2nd Edition, Rev. F | 08/2024    | Updated P1-02HSC module general specification table.  |
| 2nd Edition, Rev. G | 10/2024    | Updated P1-04NTC module Input Specification table Thermistor Input Ranges: 10K-AN Type 3.   |
| 2nd Edition, Rev. H | 01/2025    | Updated USB-RS232 cable to USB-RS232-1  |
| 2nd Edition, Rev. I | 03/2025    | Updated P1-04AD-1 and P1-04AD-2 Max Crosstalk value.  |
| 2nd Edition, Rev. J | 06/2025    | Updated P1-04AD specification table Resolution Value and Linearity Error  |
| 2nd Edition, Rev. K | 10/2025    | Added P1-622 CPU, P1-412 CPU, and P1 Mini-Brick series P1-M402, P1-M412, P1-M622 PLCs.  |
| 2nd Edition, Rev. L | 11/2025    | Upated P1-15CDD1 Input - Requires external 8A fuse circuit max.   |
| 2nd Edition, Rev. M | 11/11/2025 | Upated P1-M401-12DRS, P1-M412-12DRS, and P1-M622-12DRS modules input operating voltage, peak voltage, and input impedance values. |
| 2nd Edition, Rev. N | 01/28/2026 | Added new modules P1-04THMS, P1-04TEPS, and P1-12CDRS and styles updates.   |

# TABLE OF CONTENTS

---

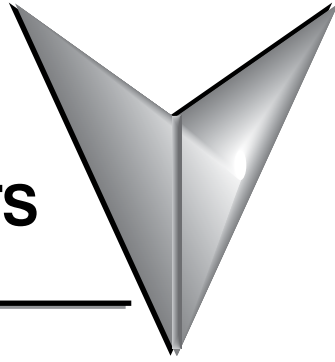

|   |            |
|---|------------|
| User Caution .....                              | i          |
| Publication History.....                        | iv         |
| Table of Contents.....                          | vi         |
| <b>Chapter 1 - Getting Started.....</b>         | <b>1-1</b> |
| Introduction .....                              | 1-2        |
| Purpose of this Manual.....                     | 1-2        |
| About Getting Started.....                      | 1-2        |
| Online Help Files and Other Documentation.....  | 1-2        |
| Technical Support.....                          | 1-2        |
| Conventions Used.....                           | 1-3        |
| Key Topics for Each Chapter.....                | 1-3        |
| Before you begin.....                           | 1-4        |
| Productivity Suite System Requirements.....     | 1-5        |
| Step 1: Install Programming Software.....       | 1-6        |
| Step 2: Launch Programming Software.....        | 1-10       |
| Online Help.....                                | 1-11       |
| Step 3: Install Hardware.....                   | 1-12       |
| Step 4: Apply Power to CPU .....                | 1-16       |
| Step 5: Establish PC to CPU Communications..... | 1-16       |
| Step 6: Open/Read Hardware Configuration.....   | 1-17       |
| Step 7: Create a Project.....                   | 1-19       |

## Table of Contents

---

|   |             |
|---|-------------|
| Step 8: Save Project.....                                 | 1-24        |
| Step 9: Write Project to CPU.....                         | 1-25        |
| Step 10: Place CPU in RUN Mode .....                      | 1-26        |
| Step 11: Test the Project Using Monitor Mode.....         | 1-27        |
| <b>Chapter 2 - Specifications .....</b>                   | <b>2-1</b>  |
| Overview .....  | 2-6         |
| Hardware.....   | 2-6         |
| <b>P1000 Power Supplies.....</b>                          | <b>2-7</b>  |
| P1-01AC and P1-02AC Power Supplies .....                  | 2-7         |
| P1-01AC Power Supply.....                                 | 2-8         |
| P1-02AC Power Supply .....                                | 2-9         |
| P1-01DC Power Supply .....                                | 2-11        |
| Productivity®1000 Alternate Power Supply Connection ..... | 2-13        |
| <b>Productivity® 1000 P1-412 CPU Module.....</b>          | <b>2-14</b> |
| P1-412 Specifications.....                                | 2-14        |
| P1-412 General Specifications.....                        | 2-15        |
| P1-412 Module Faceplate Layout .....                      | 2-16        |
| P1-412 Communication Ports .....                          | 2-17        |
| <b>Productivity® 1000 P1-540 CPU Module .....</b>         | <b>2-22</b> |
| P1-540 Specifications.....                                | 2-22        |
| P1-540 General Specifications.....                        | 2-23        |
| P1-540 Module Faceplate Layout .....                      | 2-24        |
| P1-540 Battery.....                                       | 2-25        |
| P1-540 Communication Ports .....                          | 2-26        |
| <b>Productivity1000 P1-550 CPU Module.....</b>            | <b>2-31</b> |
| P1-550 Specifications.....                                | 2-31        |
| P1-550 Module Faceplate Layout .....                      | 2-33        |
| P1-550 Battery.....                                       | 2-34        |
| P1-550 Communication Ports .....                          | 2-35        |
| <b>Productivity® 1000 P1-622 CPU Module .....</b>         | <b>2-40</b> |
| P1-622 Specifications.....                                | 2-40        |
| P1-622 General Specifications.....                        | 2-41        |

## Table of Contents

---

|  |             |
|--|-------------|
| P1-622 Module Faceplate Layout .....                         | 2-42        |
| P1-622 External Power Terminal .....                         | 2-43        |
| P1-622 Communication Ports .....                             | 2-44        |
| <b>Productivity<sup>®</sup> 1000 Mini PLC Overview .....</b> | <b>2-49</b> |
| P1-M401 PLC Modules.....                                     | 2-50        |
| P1-M412 PLC Modules.....                                     | 2-50        |
| P1-M622 PLC Modules.....                                     | 2-50        |
| P1 Mini PLC Features .....                                   | 2-51        |
| Communication Ports.....                                     | 2-53        |
| <b>P1 Mini PLC Specifications.....</b>                       | <b>2-58</b> |
| P1-Mxxx PLC Common Specifications.....                       | 2-58        |
| P1 Mini PLC Insulation Requirements .....                    | 2-61        |
| <b>Remote Slave Module.....</b>                              | <b>2-64</b> |
| P1-RX Remote Slave Module.....                               | 2-64        |
| P1-RX Power Terminal.....                                    | 2-65        |
| P1-RX Remote I/O Example.....                                | 2-65        |
| P1-RX Setting Remote Slave Address .....                     | 2-66        |
| P1-RX Remote I/O Port.....                                   | 2-67        |
| <b>I/O Modules Overview .....</b>                            | <b>2-68</b> |
| <b>Discrete I/O Modules.....</b>                             | <b>2-69</b> |
| Discrete Input Modules.....                                  | 2-69        |
| Discrete Output Modules.....                                 | 2-69        |
| <b>Discrete Combo I/O Modules.....</b>                       | <b>2-70</b> |
| Discrete Combo Input/Output Modules.....                     | 2-70        |
| <b>I/O Modules Installation .....</b>                        | <b>2-70</b> |
| <b>P1-08SIM Input Simulator Module.....</b>                  | <b>2-71</b> |
| <b>P1-08ND-TTL DC Input.....</b>                             | <b>2-72</b> |
| Wiring Diagrams.....   | 2-74        |
| <b>P1-08ND3 Sinking/Sourcing DC Input .....</b>              | <b>2-75</b> |
| Wiring Diagrams.....   | 2-77        |
| <b>P1-16ND3 Sinking/Sourcing DC Input.....</b>               | <b>2-78</b> |
| Wiring Diagrams.....   | 2-80        |

**P1-08NE3 AC/DC Sinking/Sourcing Input** ..... 2-81  
 Wiring Diagrams ..... 2-83

**P1-16NE3 AC/DC Sinking/Sourcing Input**..... 2-84  
 Wiring Diagrams ..... 2-86

**P1-08NA AC Input**..... 2-87  
 Wiring Diagrams ..... 2-89

**P1-08TD-TTL DC Output** ..... 2-90  
 Wiring Diagrams ..... 2-92

**P1-08TD1 Sinking DC Output**..... 2-93  
 Wiring Diagrams ..... 2-95

**P1-08TD2 Sourcing DC Output**..... 2-96  
 Wiring Diagrams ..... 2-98

**P1-15TD1 Sinking DC Output** ..... 2-99  
 Wiring Diagrams ..... 2-101

**P1-15TD2 Sourcing DC Output** ..... 2-102  
 Wiring Diagrams ..... 2-104

**P1-08TA AC Output** ..... 2-105  
 Wiring Diagrams ..... 2-107

**P1-04TEPS Isolated Relay (SSR) Output**..... 2-108  
 Wiring Diagrams ..... 2-110

**P1-04TRS Isolated Relay**..... 2-111  
 Wiring Diagrams ..... 2-113

**P1-08TRS Isolated Relay**..... 2-114  
 Wiring Diagrams ..... 2-116

**P1-16TR Relay Output** ..... 2-117  
 Wiring Diagrams ..... 2-119

**P1-12CDRS Discrete Input / Isolated Relay Output**..... 2-120  
 P1-12CDRS Insulation Requirements ..... 2-122  
 Wiring Diagrams ..... 2-123

**P1-15CDD1 Input/Output** ..... 2-124  
 Wiring Diagrams ..... 2-126

## Table of Contents

---

|  |            |
|--|------------|
| P1-15CDD2 Input/Output.....                        | 2-127      |
| Wiring Diagrams.....                               | 2-129      |
| P1-16CDR Discrete Input/ Relay Output.....         | 2-130      |
| Wiring Diagrams.....                               | 2-132      |
| <b>Chapter 3 - Analog I/O Specifications .....</b> | <b>3-1</b> |
| Analog I/O Modules Overview.....                   | 3-3        |
| Analog I/O Modules.....                            | 3-4        |
| Analog Input Modules.....                          | 3-4        |
| Analog Output Modules.....                         | 3-4        |
| Analog Input/Output Modules .....                  | 3-5        |
| P1-04AD Analog Input.....                          | 3-6        |
| Wiring Diagrams.....                               | 3-8        |
| Module Configuration .....                         | 3-9        |
| P1-04AD-1 Analog Input .....                       | 3-10       |
| Wiring Diagrams.....                               | 3-12       |
| Module Configuration .....                         | 3-13       |
| P1-04AD-2 Analog Input.....                        | 3-14       |
| Wiring Diagrams.....                               | 3-16       |
| Module Configuration .....                         | 3-17       |
| P1-04ADL-1 Analog Input .....                      | 3-18       |
| Wiring Diagrams.....                               | 3-20       |
| Module Configuration .....                         | 3-21       |
| P1-04ADL-2 Analog Input.....                       | 3-22       |
| Wiring Diagrams.....                               | 3-24       |
| Module Configuration .....                         | 3-25       |
| P1-08ADL-1 Analog Input .....                      | 3-26       |
| Wiring Diagrams.....                               | 3-28       |
| Module Configuration .....                         | 3-29       |
| P1-08ADL-2 Analog Input.....                       | 3-30       |
| Wiring Diagrams.....                               | 3-32       |
| Module Configuration .....                         | 3-33       |

|   |             |
|---|-------------|
| <b>P1-04RTD Analog Input</b> .....                        | <b>3-34</b> |
| Wiring Diagrams.....                                      | 3-37        |
| Module Configuration.....                                 | 3-38        |
| <b>P1-04THMS Analog Input</b> .....                       | <b>3-39</b> |
| Wiring Diagrams.....                                      | 3-41        |
| Module Configuration.....                                 | 3-43        |
| <b>P1-04THM Analog Input</b> .....                        | <b>3-44</b> |
| Wiring Diagrams.....                                      | 3-46        |
| Module Configuration.....                                 | 3-48        |
| <b>P1-04NTC Thermistor</b> .....                          | <b>3-49</b> |
| Wiring Diagrams.....                                      | 3-51        |
| Module Configuration.....                                 | 3-52        |
| <b>P1-04DAL-1 Analog Output</b> .....                     | <b>3-53</b> |
| Wiring Diagrams.....                                      | 3-55        |
| Module Configuration.....                                 | 3-56        |
| <b>P1-04DAL-2 Analog Output</b> .....                     | <b>3-57</b> |
| Wiring Diagrams.....                                      | 3-59        |
| Module Configuration.....                                 | 3-60        |
| <b>P1-08DAL-1 Analog Output</b> .....                     | <b>3-61</b> |
| Wiring Diagrams.....                                      | 3-63        |
| Module Configuration.....                                 | 3-64        |
| <b>P1-08DAL-2 Analog Output</b> .....                     | <b>3-65</b> |
| Wiring Diagrams.....                                      | 3-67        |
| Module Configuration.....                                 | 3-68        |
| <b>P1-4ADL2DAL-1 Current Analog Input/Output</b> .....    | <b>3-69</b> |
| Wiring Diagrams.....                                      | 3-72        |
| Module Configuration.....                                 | 3-73        |
| <b>P1-4ADL2DAL-2 Voltage Analog Input/Output</b> .....    | <b>3-74</b> |
| Wiring Diagrams.....                                      | 3-77        |
| Module Configuration.....                                 | 3-78        |
| <br>  |             |
| <b>Chapter 4 - Specialty Modules Specifications</b> ..... | <b>4-1</b>  |
| Specialty Modules Overview.....                           | 4-2         |
| P1-02HSC High-Speed Isolated Sinking/Sourcing Input.....  | 4-3         |

## Table of Contents

---

|  |             |
|--|-------------|
| Wiring Diagrams.....                                       | 4-5         |
| Wiring Example for Koyo Open Collector Output Encoder..... | 4-6         |
| Wiring Example for Koyo Totem Pole Output Encoder.....     | 4-7         |
| Module Configuration.....                                  | 4-8         |
| <b>P1-04PWM Module.....</b>                                | <b>4-9</b>  |
| Wiring Diagrams.....                                       | 4-11        |
| Module Configuration.....                                  | 4-12        |
| <b>High-Speed Module Tester Utility.....</b>               | <b>4-13</b> |
| <br>   |             |
| <b>Chapter 5 - Installation and Wiring.....</b>            | <b>5-1</b>  |
| <b>Safety Guidelines.....</b>                              | <b>5-3</b>  |
| Plan for Safety.....                                       | 5-3         |
| Three Levels of Protection.....                            | 5-4         |
| Orderly System Shutdown.....                               | 5-4         |
| System Power Disconnect.....                               | 5-4         |
| Emergency Stop Circuits.....                               | 5-5         |
| <b>Productivity®1000 Mechanical Design.....</b>            | <b>5-6</b>  |
| Typical Productivity1000 System.....                       | 5-6         |
| <b>Dimensions and Installation.....</b>                    | <b>5-7</b>  |
| <b>Basic Dimensions.....</b>                               | <b>5-10</b> |
| P1-01AC, P1-02AC and P1-01DC Power Supplies.....           | 5-10        |
| P1-412/ P1-540 /P1-550 /P1-622 CPUs.....                   | 5-10        |
| P1-RX Module.....  | 5-11        |
| I/O Modules.....   | 5-11        |
| P1-Mxxx PLC Modules.....                                   | 5-12        |
| <b>Mounting Guidelines.....</b>                            | <b>5-13</b> |
| Enclosures.....  | 5-13        |
| Mounting Position.....                                     | 5-13        |
| Using Mounting Rails.....                                  | 5-13        |
| Mounting Clearances.....                                   | 5-14        |
| Temperature Considerations.....                            | 5-14        |
| Power Considerations.....                                  | 5-14        |
| Grounding ..   | 5-15        |
| Agency Approvals.....                                      | 5-15        |

|  |             |
|--|-------------|
| Installing the Power Supply.....                               | 5–16        |
| DIN Rail Mounting P1000 System .....                           | 5–17        |
| Surface Mounting P1000 System.....                             | 5–17        |
| Installing the I/O Modules.....                                | 5–18        |
| <b>Wiring Guidelines .....</b>                                 | <b>5–19</b> |
| Power Supply Wiring.....                                       | 5–19        |
| Grounding .....  | 5–19        |
| Fuse Protection.....   | 5–20        |
| <b>I/O Module Wiring Options .....</b>                         | <b>5–21</b> |
| Hand Wiring System.....  | 5–21        |
| ZIPLink Wiring System.....                                     | 5–22        |
| Terminal Block With Pigtail Cable.....                         | 5–22        |
| Input and Output Modules ZIPLink Selections.....               | 5–23        |
| Analog Modules ZIPLink Selections.....                         | 5–24        |
| P1 Mini Series PLC Modules ZIPLink Selections.....             | 5–25        |
| Removable Terminal Blocks (Optional) .....                     | 5–26        |
| P1-10RTB and P1-10RTB-1 .....                                  | 5–26        |
| P2-RTB and P2-RTB-1 .....                                      | 5–26        |
| Terminal Block Installation.....                               | 5–27        |
| Terminal Block Removal .....                                   | 5–28        |
| Planning the I/O Wiring Routes.....                            | 5–28        |
| <b>System Wiring Strategies.....</b>                           | <b>5–29</b> |
| CPU Isolation Boundaries.....                                  | 5–29        |
| Sinking/Sourcing Concepts .....                                | 5–30        |
| I/O “Common Terminal” Concepts .....                           | 5–31        |
| DC Input Wiring Methods.....                                   | 5–32        |
| DC Output Wiring Methods.....                                  | 5–32        |
| Relay Outputs - Wiring Methods.....                            | 5–34        |
| Relay Outputs – Transient Suppression for Inductive Loads..... | 5–35        |
| CPU’s Integrated Transient Suppressors.....                    | 5–36        |
| Types of Additional Transient Protection.....                  | 5–37        |
| <b>Chapter 6 - Communications .....</b>                        | <b>1</b>    |
| <b>Communications .....</b>                                    | <b>6-1</b>  |
| Communication Ports.....                                       | 6-1         |
| P1 Mini PLC Communications .....                               | 6-3         |

## Table of Contents

---

|   |             |
|---|-------------|
| microSD Card: .....   | 6-4         |
| MicroUSB: .....   | 6-4         |
| RS-232: .....   | 6-4         |
| <b>Communications: Connectivity</b> .....                             | <b>6-10</b> |
| CPU Port Connections, P1-540 CPU .....                                | 6-10        |
| <b>Communications: Connectivity</b> .....                             | <b>6-11</b> |
| CPU Port Connections, P1-550 and P1-622 CPUs.....                     | 6-11        |
| ASCII and Custom Protocol Functionality.....                          | 6-16        |
| ASCII Instructions .....  | 6-16        |
| Custom Protocol Instructions.....                                     | 6-17        |
| <b>Communications: Ethernet</b> .....                                 | <b>6-19</b> |
| TCP and UDP Port Numbers.....   | 6-19        |
| IP Addressing and Subnetting.....                                     | 6-19        |
| PC Setup.....   | 6-20        |
| CPU Setup .....   | 6-21        |
| TCP Connection Behavior with Modbus TCP and Network Instructions..... | 6-22        |
| <b>Communications Modbus Functionality</b> .....                      | <b>6-23</b> |
| Master/Client Function Code and Data Type Support.....                | 6-23        |
| Slave/Server Function Code and Data Type Support.....                 | 6-25        |
| Assigning Modbus Addresses to Tags .....                              | 6-26        |
| Modbus Options.....   | 6-29        |
| Modbus Instructions .....   | 6-32        |
| Network Instructions.....   | 6-34        |
| Automatic Poll versus Manual Polling and Interlocking.....            | 6-35        |
| Message Queue .....   | 6-37        |
| <b>EtherNet/IP for the Productivity Series</b> .....                  | <b>6-38</b> |
| Terminology Definitions.....  | 6-38        |
| Network Layer Chart.....  | 6-39        |
| EtherNet/IP Data.....   | 6-39        |
| Class 1 and Class 3 Connections.....                                  | 6-40        |
| Setup Example 1: Productivity®1000 as EtherNet/IP Adapter .....       | 6-40        |
| Example 2: Productivity®1000 as EtherNet/IP Scanner.....              | 6-43        |
| Troubleshooting Tips:.....  | 6-46        |
| EtherNet/IP I/O Message Troubleshooting:.....                         | 6-48        |
| EtherNet/IP Explicit Message Troubleshooting:.....                    | 6-48        |

|   |             |
|---|-------------|
| ProNET .....  | 6-49        |
| Custom Protocol over Ethernet Functionality .....         | 6-50        |
| Hardware Configuration .....                              | 6-51        |
| Custom Protocol Ethernet Instruction.....                 | 6-52        |
| <b>Communications: Remote I/O and GS-Drives .....</b>     | <b>6-53</b> |
| Design Considerations for Remote I/O and GS-Drives .....  | 6-53        |
| <b>Communications: Port Configuration.....</b>            | <b>6-59</b> |
| External Ethernet Port Settings .....                     | 6-60        |
| Local Ethernet Port Settings.....                         | 6-61        |
| Remote Access Configuration .....                         | 6-61        |
| Serial Configuration.....                                 | 6-62        |
| RS-232 and RS-485 Port Settings .....                     | 6-62        |
| <b>Communications: Error Codes.....</b>                   | <b>6-65</b> |
| <b>P1000 EtherNet/IP Error Codes .....</b>                | <b>6-66</b> |
| <br>  |             |
| <b>Chapter 7 - Maintenance and Troubleshooting .....</b>  | <b>7-1</b>  |
| <b>Hardware Maintenance .....</b>                         | <b>7-3</b>  |
| Standard Maintenance .....                                | 7-3         |
| Air Quality Maintenance .....                             | 7-3         |
| CPU Battery Replacement.....                              | 7-3         |
| <b>Diagnostics .....</b>                                  | <b>7-4</b>  |
| Diagnostics .....   | 7-4         |
| Critical Errors .....                                     | 7-4         |
| Non-Critical Errors.....                                  | 7-4         |
| Finding Diagnostic Information .....                      | 7-4         |
| Error Codes .....   | 7-4         |
| <b>CPU Functions Indicators .....</b>                     | <b>7-5</b>  |
| <b>PWR Indicator .....</b>                                | <b>7-6</b>  |
| Faulty or Incorrect Power Supply .....                    | 7-6         |
| Faulty CPU .....  | 7-6         |
| Device or Module Causes the Power Supply to Shutdown..... | 7-7         |
| <b>Run Indicator 7-8</b>                                  |             |

## Table of Contents

---

|   |            |
|---|------------|
| CPU Indicator.....                                      | 7-8        |
| Communications Problems.....                            | 7-8        |
| I/O Module Troubleshooting.....                         | 7-9        |
| Things to Check.....                                    | 7-9        |
| Error Codes.....  | 7-9        |
| Some Quick Steps.....                                   | 7-9        |
| Testing Output Points.....                              | 7-10       |
| Noise Troubleshooting.....                              | 7-11       |
| Electrical Noise Problems.....                          | 7-11       |
| Reducing Electrical Noise.....                          | 7-11       |
| Run Time vs. Stop Mode Transfer Instruction.....        | 7-12       |
| Run Time Transfers.....                                 | 7-13       |
| Stop Mode Transfers.....                                | 7-13       |
| Forcing I/O Points.....                                 | 7-15       |
| Advantages of Forces.....                               | 7-15       |
| Enabling Forces.....                                    | 7-15       |
| Forcing Tags in Your System.....                        | 7-16       |
| Identifying Forced Values.....                          | 7-18       |
| Force Value Timing Chart.....                           | 7-19       |
| <b>Appendix A - European Union Directives (CE).....</b> | <b>A-1</b> |
| European Union (EU) Directives.....                     | A-2        |
| Member Countries.....                                   | A-2        |
| Applicable Directives.....                              | A-2        |
| Compliance.....   | A-2        |
| General Safety.....                                     | A-4        |
| Special Installation Manual.....                        | A-4        |
| Other Sources of Information.....                       | A-4        |
| Basic EMC Installation Guidelines.....                  | A-5        |
| Enclosures.....   | A-5        |
| Mains Filters.....                                      | A-5        |
| Suppression and Fusing.....                             | A-5        |
| Internal Enclosure Grounding.....                       | A-5        |
| Equipotential Grounding.....                            | A-5        |

Communications and Shielded Cables ..... A-6

Analog and RS232 Cables ..... A-7

Multidrop Cables ..... A-7

Shielded Cables Within Enclosures ..... A-7

Analog Modules and RF Interference ..... A-7

Network Isolation ..... A-8

Items Specific to the Productivity®1000 ..... A-9

**Appendix B - Productivity®1000 Error Codes..... B-1**

    Communications Error Codes ..... B-2

    Module Error Codes ..... B-3

    CPU Error Codes ..... B-4

    Project Error Codes ..... B-5

    Project Error Messages ..... B-7

**Appendix C - Security Considerations for Control Systems Networks..... C-1**

    Security Considerations for Control Systems Networks ..... C-2



# GETTING STARTED

---



## In This Chapter...

|   |      |
|---|------|
| Introduction .....                                | 1-2  |
| Purpose of this Manual.....                       | 1-2  |
| About Getting Started.....                        | 1-2  |
| Online Help Files and Other Documentation.....    | 1-2  |
| Technical Support.....                            | 1-2  |
| Conventions Used.....                             | 1-3  |
| Key Topics for Each Chapter.....                  | 1-3  |
| Before you begin... ..                            | 1-4  |
| Productivity Suite System Requirements.....       | 1-5  |
| Step 1: Install Programming Software.....         | 1-6  |
| Step 2: Launch Programming Software .....         | 1-10 |
| Step 3: Install Hardware.....                     | 1-12 |
| Step 4: Apply Power to CPU .....                  | 1-16 |
| Step 5: Establish PC to CPU Communications.....   | 1-16 |
| Step 6: Open/Read Hardware Configuration.....     | 1-17 |
| Step 7: Create a Project.....                     | 1-19 |
| Step 8: Save Project.....                         | 1-25 |
| Step 9: Write Project to CPU.....                 | 1-26 |
| Step 10: Place CPU in RUN Mode .....              | 1-27 |
| Step 11: Test the Project Using Monitor Mode..... | 1-28 |

# Introduction

## Purpose of this Manual

Thank you for purchasing the AutomationDirect Productivity®1000 Programmable Controller (CPU) family of products. This hardware user manual provides information that will help you install, set up, program, troubleshoot, and maintain your Productivity1000 CPU system. The manual includes information that is critical to the safety of the personnel who will install and use the controller and to the machinery, processes, and equipment controlled by the CPU.

The manual also includes important information about power and signal wiring, mounting of the CPU, and configuring the CPU system.

## About Getting Started

If you are familiar with Programmable Controllers in general, then following the simple steps in this first chapter may be all you require to start being productive using a Productivity1000 CPU system. After you have completed the steps, your Productivity1000 controller will be running the ladder logic project that you programmed.

## Online Help Files and Other Documentation

The Productivity1000 programming software, Productivity Suite, is available as a download from our website.

**See <http://www.automationdirect.com/products/pseries.html>.**

The Productivity Suite software includes searchable online help topics covering all aspects of the software, instruction set, module setup, and communications.

In addition, each power supply, CPU, and I/O module includes an installation insert.

## Technical Support

We strive to make our manuals the best in the industry. We rely on your feedback to let us know if we are reaching our goal. If you cannot find the solution to your particular application, or if for any reason you need technical assistance, please call us at:

**1-770-844-4200**

Our technical support group will work with you to answer your questions. They are available Monday through Friday from 9:00 A.M. to 6:00 P.M. Eastern Time. We also encourage you to visit our web site where you can find information about our company and specific technical information about a wide array of our products.

<http://www.automationdirect.com>

## Conventions Used



**NOTE:** When you see the “note pad” icon in the left-hand margin, the paragraph to its immediate right will be a special note. Notes represent information that may make your work quicker or more efficient. The word **NOTE** in boldface will mark the beginning of the text.



**WARNING:** When you see the “exclamation point” icon in the left-hand margin, the paragraph to its immediate right will be a warning. This information could prevent injury, loss of property, or even death in extreme cases. Any warning in this manual should be regarded as critical information that should be read in its entirety. The word **WARNING** in boldface will mark the beginning of the text.

### Key Topics for Each Chapter

The beginning of each chapter will list the key topics that can be found in that chapter.

| GETTING STARTED                                |  | CHAPTER<br>1 |
|--|--|--------------|
| <b>In This Chapter...</b>                      |  |              |
| Introduction.....                              |  | 1-2          |
| Purpose of the Manual.....                     |  | 1-2          |
| About Getting Started.....                     |  | 1-2          |
| Online Help Files and Other Documentation..... |  | 1-2          |
| Technical Support.....                         |  | 1-2          |
| Conventions Used.....                          |  | 1-3          |
| Key Topics for Each Chapter.....               |  | 1-3          |
| Before you Begin.....                          |  | 1-4          |
| Productivity Suite System Requirements.....    |  | 1-5          |
| Productivity Suite Software Requirements.....  |  | 1-6          |

## Before you begin...

It is recommended that the following items be available to make this short step-by-step introduction to the Productivity1000 System go smoothly.

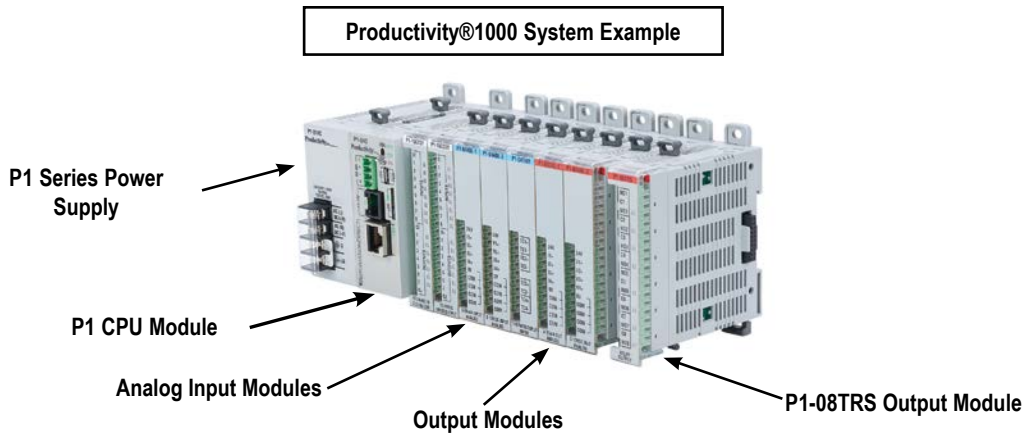

PC Running Windows OS



Not available from Automationdirect.com

Productivity Suite Programming Software PS-PGMSW



Download software from our website at: [www.automationdirect.com](http://www.automationdirect.com) under "Programmable Controllers".

USB-A to Micro USB-B Programming Cable



Screwdriver TW-SD-MSL-1



Wire Strippers DN-WS



Hookup Wire



AC Power Cord



Not available from Automationdirect.com.

## Productivity Suite System Requirements



Productivity Suite, a Windows-based programming software, is available as a FREE download at <https://www.automationdirect.com/support/software-downloads#main-content>. Please check our website for this product's current operating system requirements.



---

**NOTE:** USB or Ethernet cable is also required for communications between PC and CPU.

---

## Step 1: Install Programming Software



1. Download the latest version of the Productivity Suite Programming Software from the Automationdirect website, or insert the Productivity Suite Programming Software USB thumb drive into your PC USB port.
2. By default Productivity Suite will be saved in the "Download" folder as a ".zip" file.
  - Right Click on the ProSuite\_xxx.zip file in the Download folder.
  - Choose "Extract All" from the drop-down menu. A popup box will open.
  - Select the "Browse" button and navigate to the folder where you prefer to store the program.
  - Click on "Select Folder" button and in the next box choose "Extract".



**NOTE:** See the *Productivity Suite Installation* and *Productivity Suite Startup* topics for additional details if needed.

3. Navigate to the chosen folder and double click on the ProSuite ".exe" file.
4. The "Setup Wizard" window (shown below) will appear. Select Next.

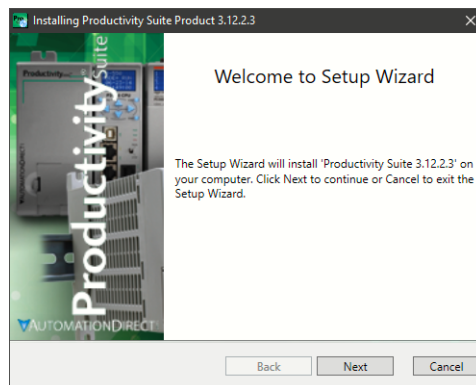

5. Carefully read the software license agreement. If you agree to the terms and conditions of this agreement, select the "I accept the terms of the License Agreement" and then the "Next" button.

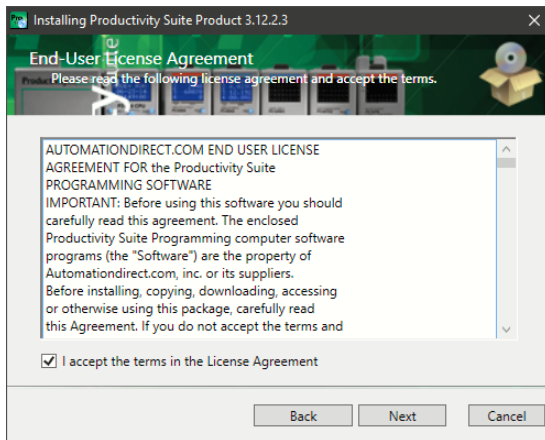

6. The "Destination Folder" window will open next. The default location will appear in the text box: C:\Program Files\AutomationDirect\Productivity Suite <Software Version>. Should you desire a different folder choose:
  - a. Browse: This option allows you to select another folder for installation.

If the installer detects a previous version of Productivity Suite on your PC, there is another option available with this window:

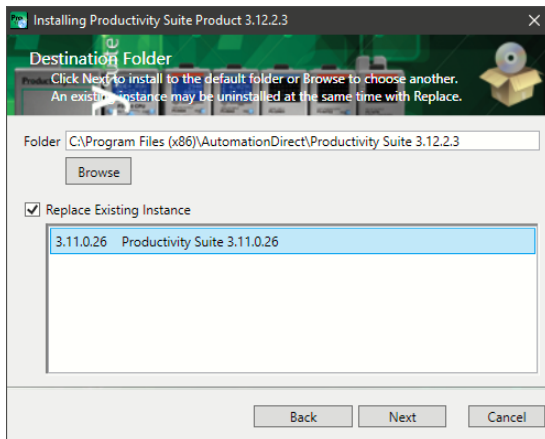

- b. Replace Existing Instance: This option allows you to uninstall the previous version of the software and install the new version in its place. If you check this option, select the version in the window that you want to delete. Click "Next" to continue.

7. Once you have selected the install folder or after deleting any previous instances, click "Install" to begin the installation.

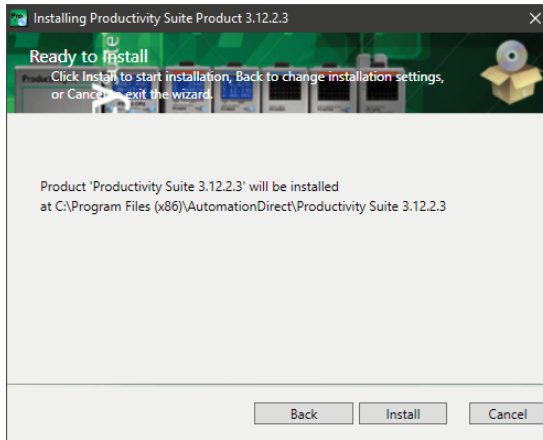

A status window will appear displaying the status of the installation.

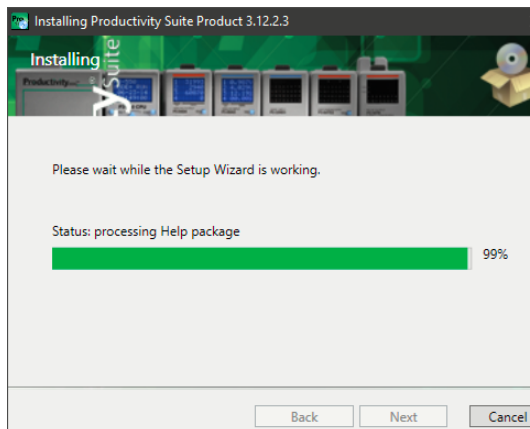

A shortcut icon will automatically be placed on the Desktop during installation.



- The next screen to appear contains the Release Notes for this version of the Productivity Suite software. This is an opportunity to review the software version release notes. You may read these before selecting the "Next" button.

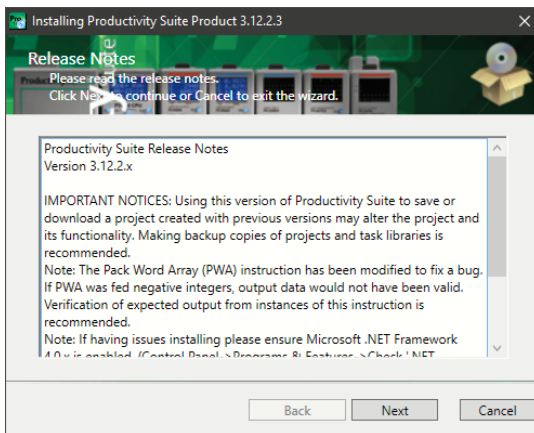

- The Installation is now complete. Select "Done".

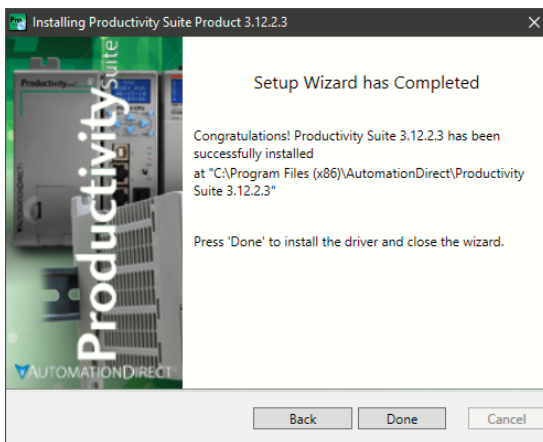

## Step 2: Launch Programming Software

After installing the Productivity Suite Programming Software, PS-PGMSW, launch the software by double clicking the desktop Productivity Suite Icon. Or from the PC's 'Start' menu, select Productivity Suite x.x.x.x.

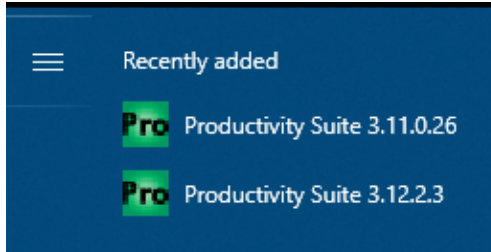

The Productivity Suite Programming Software will start up and display the Main Window as shown here.



**NOTE:** The recommended minimum screen size for the Productivity Suite Software is 1920 X 1080 pixels.

Click on the 'Start a New Project' in the Start Productivity dialog box to open a programming window.

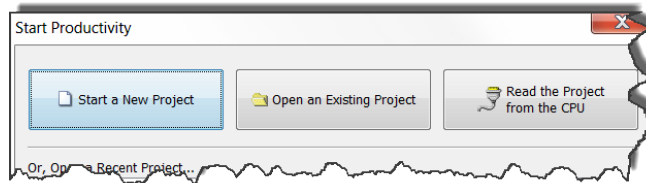

The Programming Window is divided into menus and toolbars that work together to make project development as simple as possible.

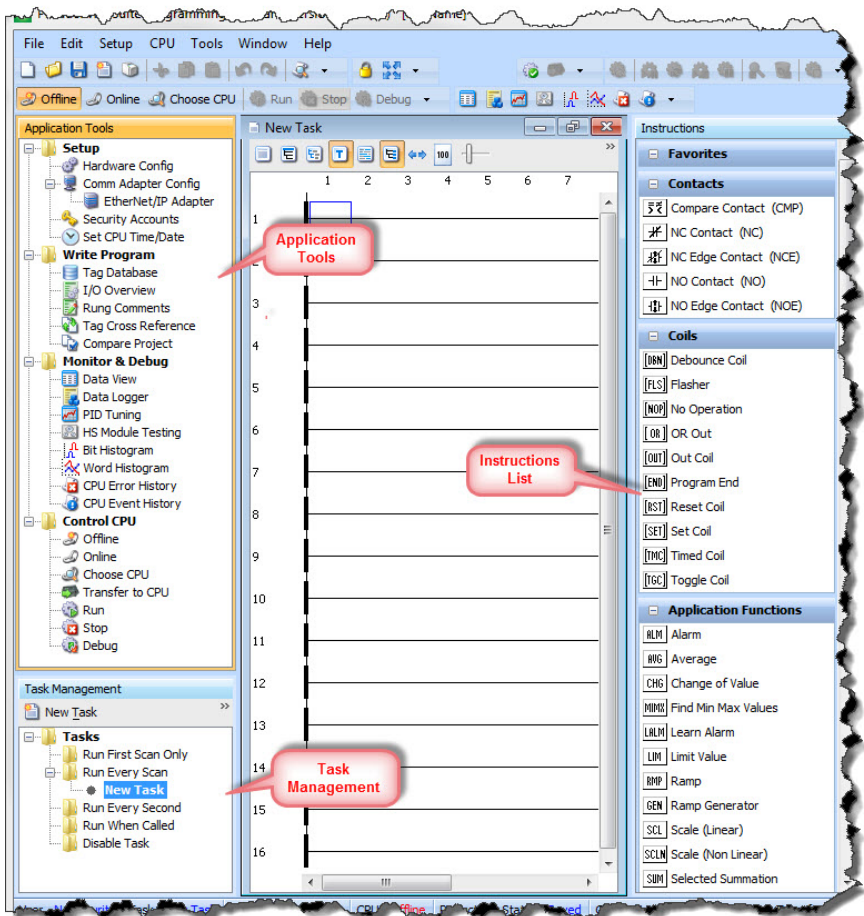

## Online Help

It is essential that you use the Productivity Suite online Help to familiarize yourself with the software. Keep it open on your desktop and refer to it frequently as you build your system. Click on the toolbar Help button to open the Help file.

## Step 3: Install Hardware

The Productivity®1000 CPU system components snap together to form a configured CPU in minutes. See Chapter 5, Installation and Wiring, for more detailed hardware installation information. What follows are the basic steps:

1. Connect power supply to CPU (after removing the optional power connector).

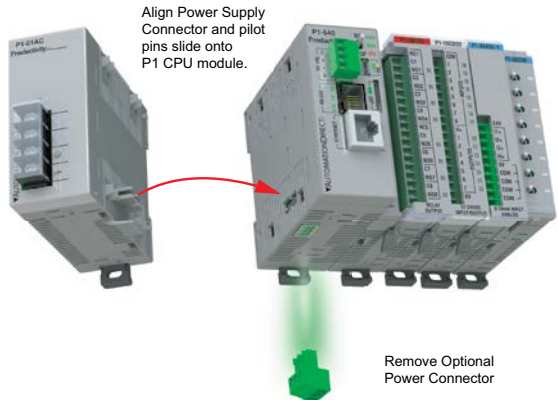

---

**NOTE:** *Optional Power Connector must be removed before connecting a Productivity1000 Power Supply. This precludes connection of two separate power supplies.*

---

2. OR use an appropriately fused alternate power source, connecting directly to CPU Optional Power Connector terminals.

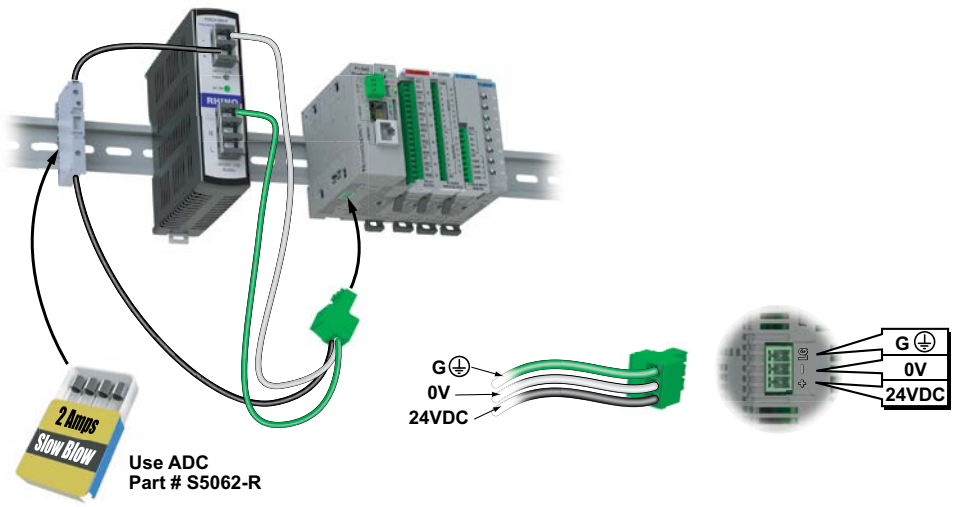

3. Install I/O Modules and engage locking tabs.

**Step One:**

With latch in “locked” position, align connectors on the side of each module and stack by pressing together. An audible click indicates lock is engaged.

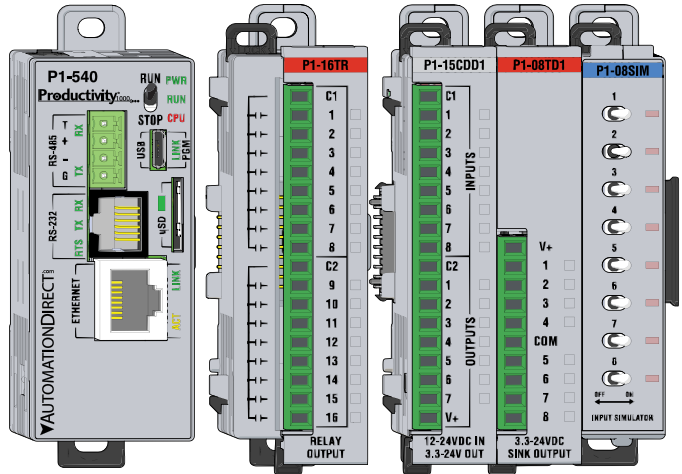
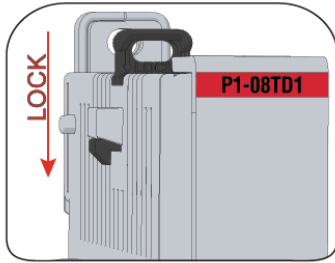

**Step Two:**

To unstack modules, pull locking latch up into the unlocked position and then pull modules apart.



**WARNING:** Explosion hazard – Do not connect, disconnect modules or operate switches while circuit is live. Productivity®1000 System does not support Hot Swapping!

4. Connect appropriate wiring to the power supply (P1-01AC) and I/O (P1-08TRS module) in this example.

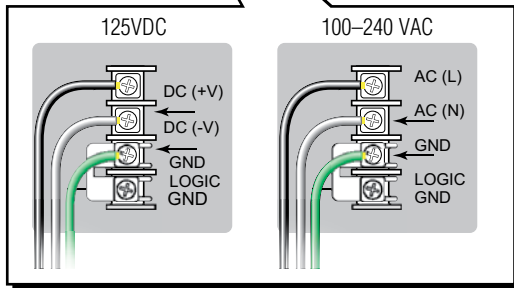
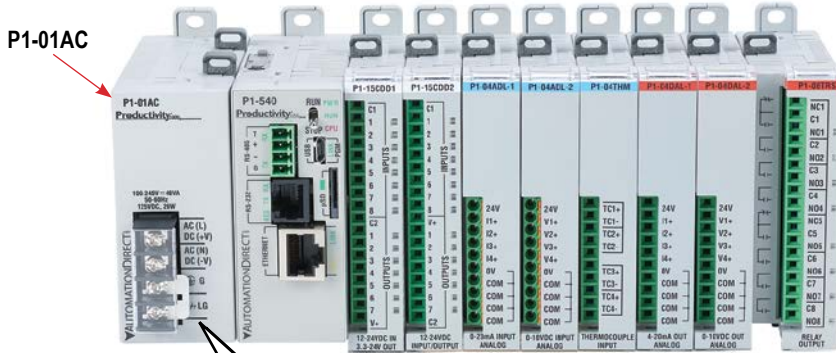

The power supply and load are connected through a DC or AC current source.

5. Connect USB cable. Use a Micro USB cable with a Type A and Micro Type B connectors as shown below.

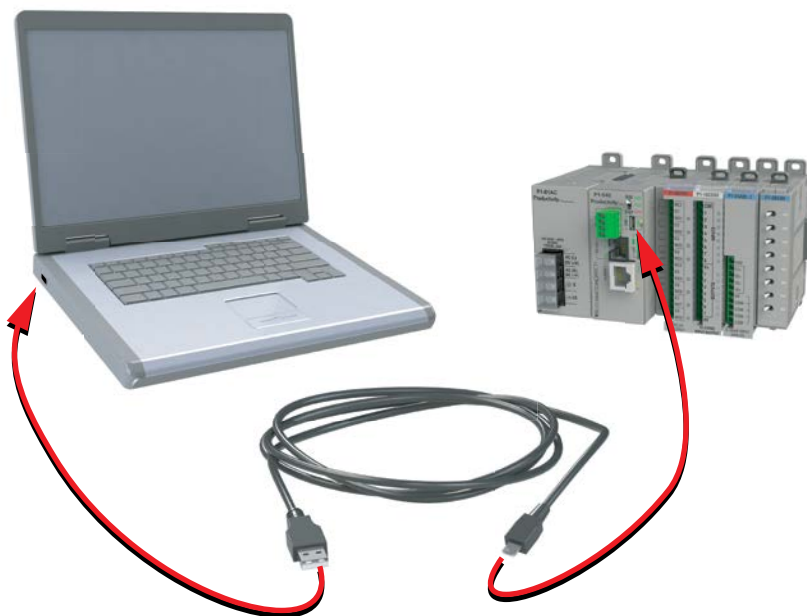

## Step 4: Apply Power to CPU

Ensure proper wiring and the correct voltage is available before connecting wiring to the power supply. Once this is verified, connect power to the power supply. Once power is applied, the CPU will perform a self evaluation and verification. See Chapters 2 and 5 of this manual for more power supply and I/O wiring information.

## Step 5: Establish PC to CPU Communications

Select "Choose CPU" icon on the CPU Toolbar and the dialog box shown below will appear.

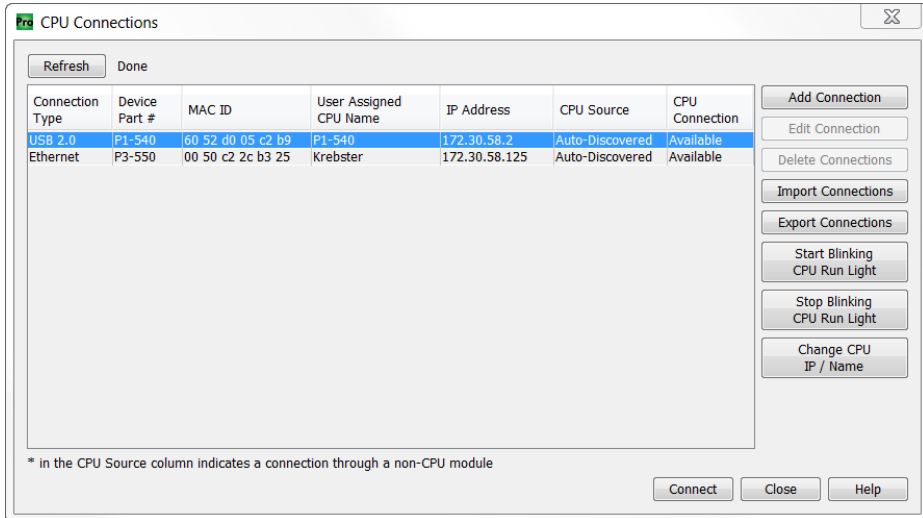

Highlight the installed CPU listed in the dialog box and select "Connect".

When initially going Online with the CPU, a pop-up window will notify you of a project difference between the CPU and the PC. Select "No, Use PC Project" command button.

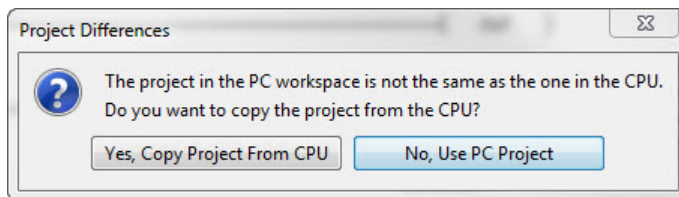

## Step 6: Open/Read Hardware Configuration

Before we create a project we must configure the hardware so we'll have default input and output tags for use in our project. With the CPU in "STOP" Mode, select Hardware Configuration under Application Tools and the following screen opens.

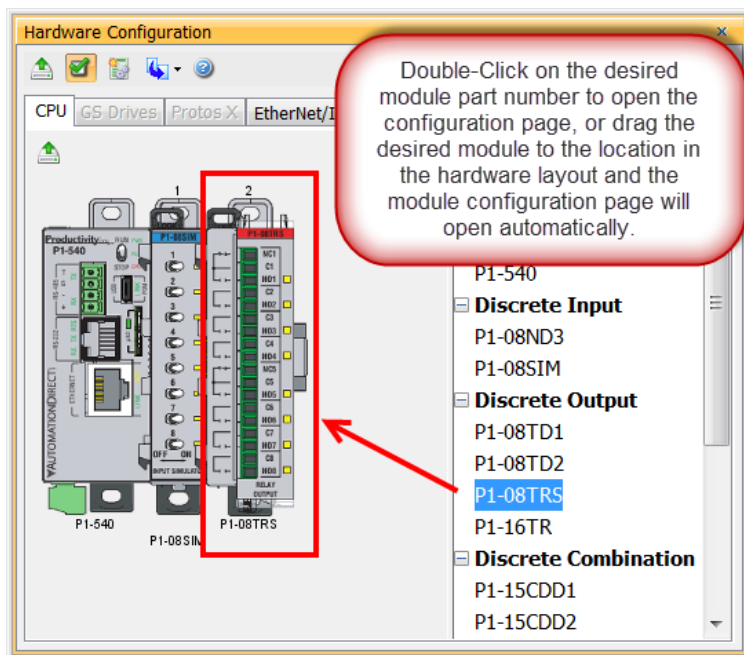
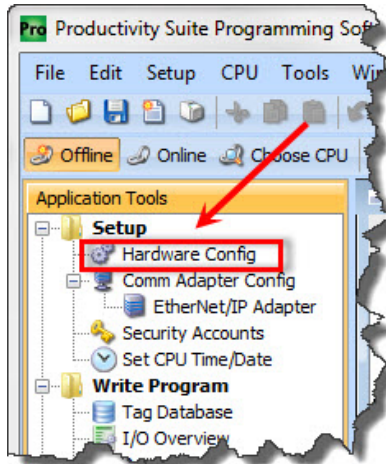

## Chapter 1: Getting Started

The Module Configuration screen shows the user tag names for all eight I/O points. Select "OK".

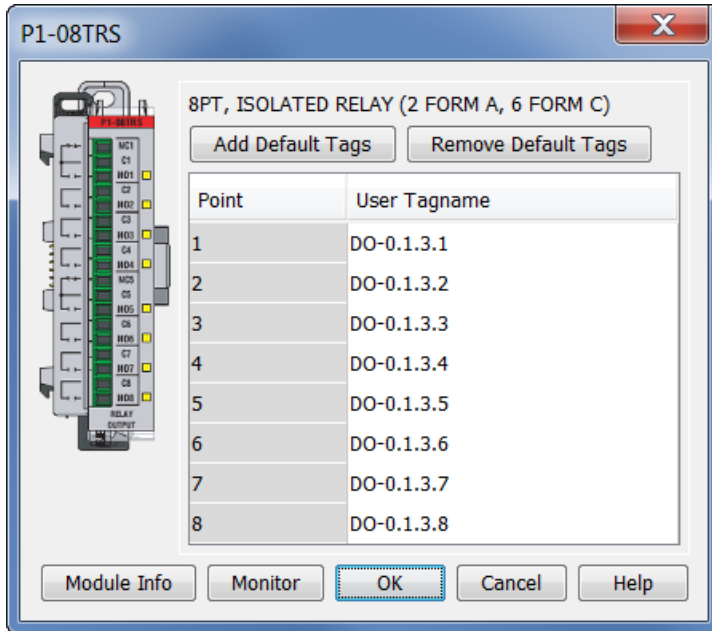

## Step 7: Create a Project

We will start a new project by entering a simple ladder logic program in the order that follows.

### Rung #1

Select the “END” position on Rung #1 with your cursor. From the Instruction List on the right, scroll down to Counters/Timers section and double click on the Simple Timer (STMR) instruction. The “Simple Timer” instruction is automatically placed on the selected rung and the Simple Timer (STMR) dialog box pops up.

1. Enter 'T1\_SP' into the Preset Value field.
2. Enter 'T1\_CURVAL' into the Current Value field.
3. Enter 'T1\_DN' into the Done field.

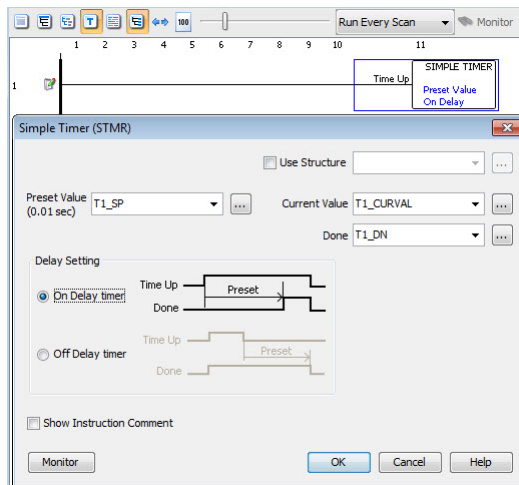

4. Select “OK”.

The Define Tags dialog box opens.

5. Enter preset time value of 300 (ms) into “Initial Value” field for Tag T1\_SP. Select OK.

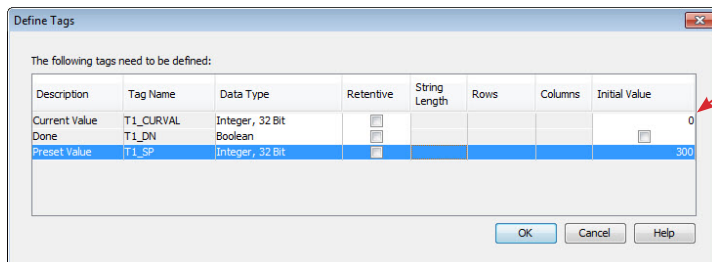

## Chapter 1: Getting Started

Place the cursor on the first position on Rung #1 as shown below. In the Instruction List on the right, scroll up to Contacts section and double click on "NO Contact (NO)". A NO Contact (NO) is placed at this rung position and a dialog box pops up.

1. Enter 'T1\_Start' into the text box.
2. Select OK.

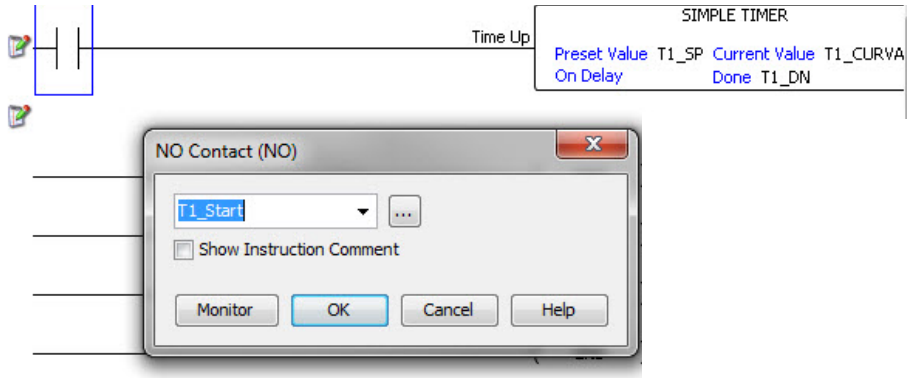

- The Define Tags dialog box opens. Select "OK".

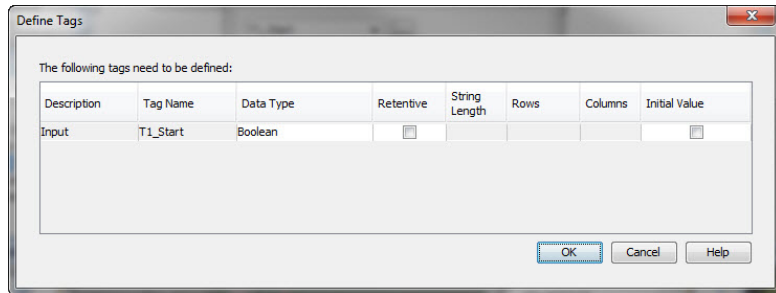

With the cursor on Rung #1, to the right of contact 'T1\_Start', we are going to begin drawing a branch circuit. Under the Edit drop down menu, select "Wire", then select "Down". Notice that a wire has been added.

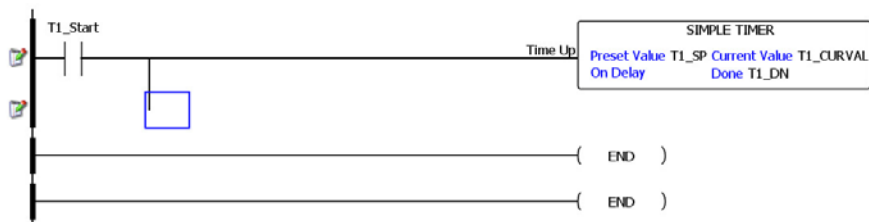
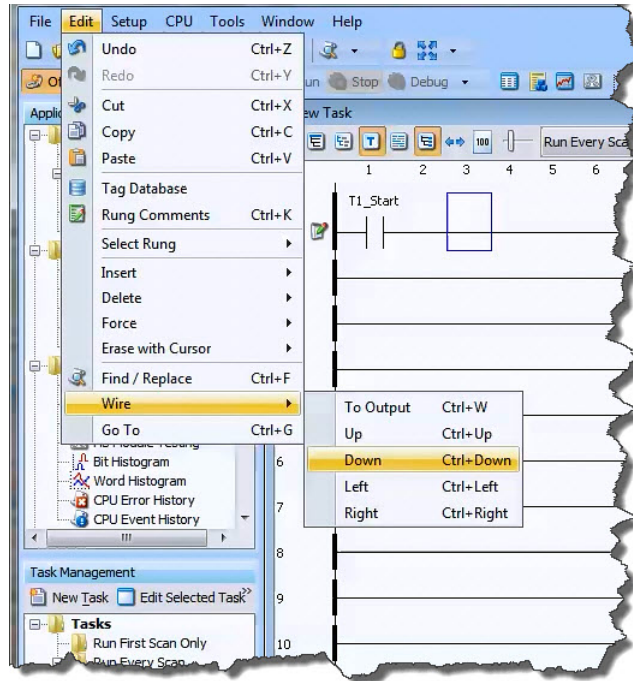

**NOTE:** There is also a wire Erase With Cursor tool in the Edit drop down menu that is used to erase any lines that were created using the Wire tools.

## Chapter 1: Getting Started

Next we'll draw a wire to the left. Under the Edit drop down menu, select "Wire", then select "Left".

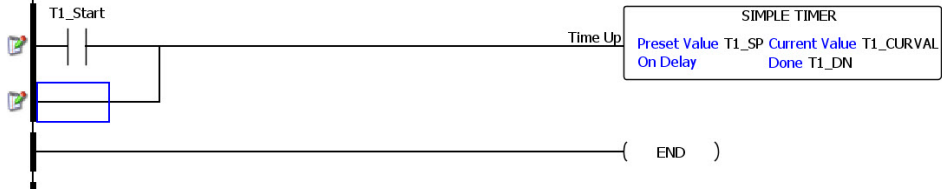

Next we'll add another normally-open contact. Place the box cursor on the first position on the newly created SubRung #1. From the Instruction list, click & drag a Contact (NO) into this box. A NO Contact (NO) dialog box pops up.

1. Enter 'T1\_Manual' into the field.
2. Select "OK".

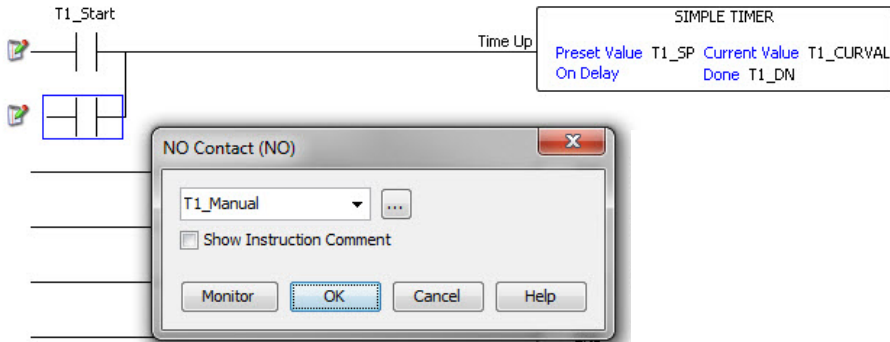

The Define Tags dialog box opens. Select "OK".

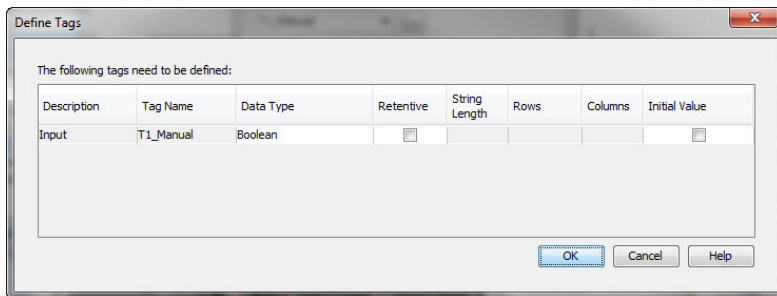

**Rung #2**

Next we'll add another normally-open contact at the start of Rung #2. Click & drag a "NO Contact (NO)" into this box. A NO Contact (NO) dialog box pops up.

1. In the empty tag field press the down arrow on the right to open a drop-down list; scroll down and select 'T1\_DN'.
2. Select "OK".

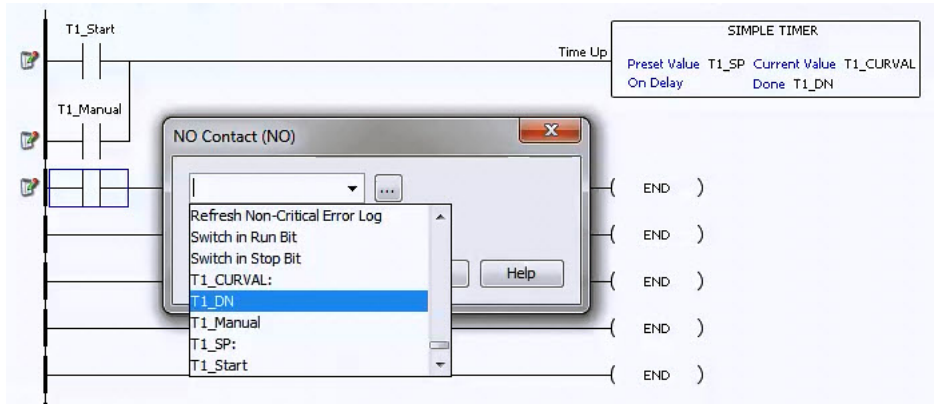

Next we'll add an Out coil at the end of the rung. Place the cursor at the end of the rung. From the Instructions list Coil section, double click on an "Out Coil (OUT)". An Out Coil (OUT) is placed on the rung and a dialog box pops up.

1. In the tag field press the down arrow on the right to open a drop-down list; scroll down and select 'DO-0.1.2.1'.
2. Select OK.

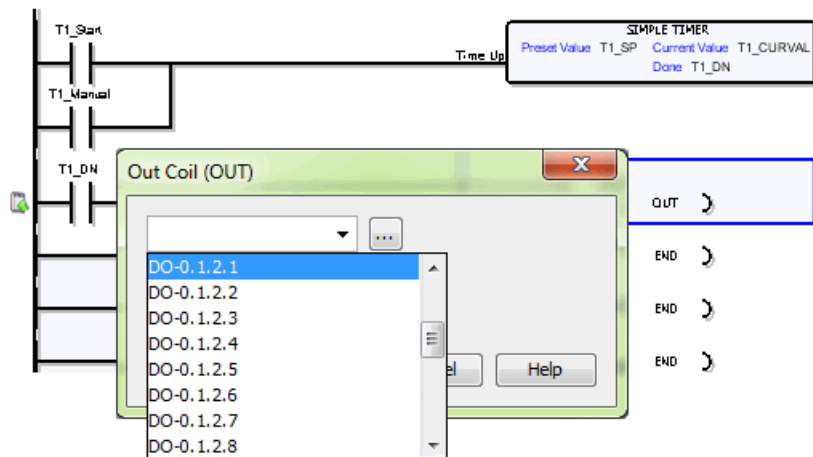

## Chapter 1: Getting Started

The ladder program now looks like this. When either of the T1 contacts are energized, the timer starts. When it times out, contact T1\_DN energizes and turns on the rung 2 output.

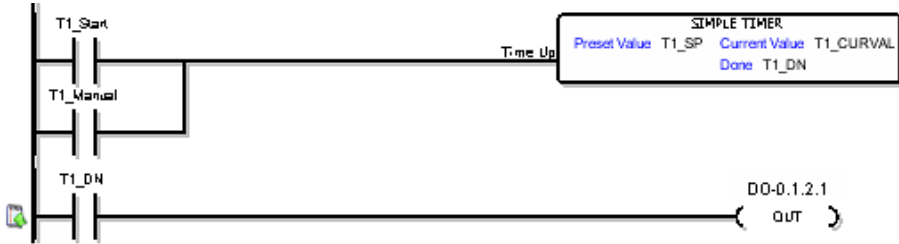

## Step 8: Save Project

Save the project by opening the File drop-down menu and selecting Save Project.

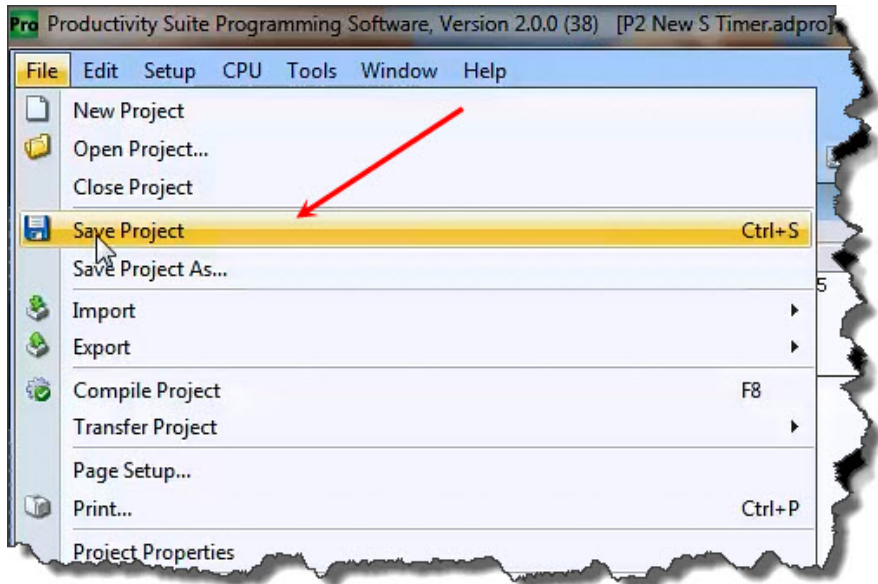

## Step 9: Write Project to CPU

Next we will transfer the project to the CPU. Transfer Project is accessed by selecting Transfer Project from the File Menu.

Select "To CPU" from the Transfer Project menu.

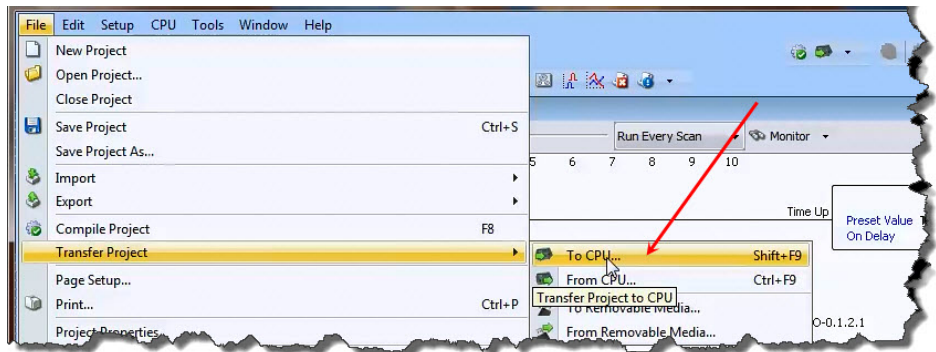

The project will then be Transferred to the CPU from the PC. During the transfer a status window will open displaying the process.

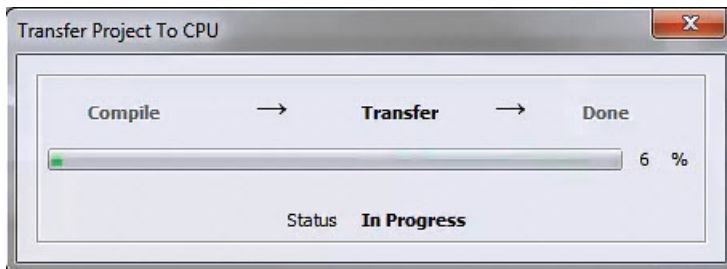

## Step 10: Place CPU in RUN Mode

Next, verify the Run/Stop switch on the CPU faceplate is placed in the Run position and then place the CPU in RUN mode on the Productivity Software Toolbar so the ladder logic program executes.

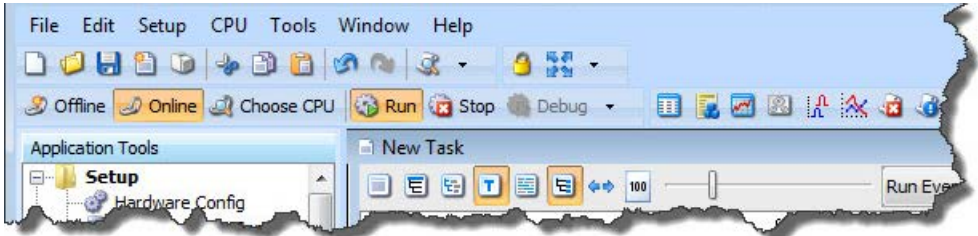

---

**NOTE:** If the Run/Stop switch on the CPU is in the Stop position, the Run button on the Programming Software Toolbar will be disabled.

---

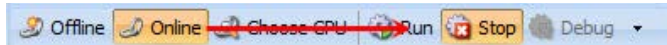

## Step 11: Test the Project Using Monitor Mode

In this next step, use the Monitor Mode and Data View to test the ladder logic program. Select Monitor Mode from the top of the Ladder Logic screen to display the status of Boolean and Integer Tags.

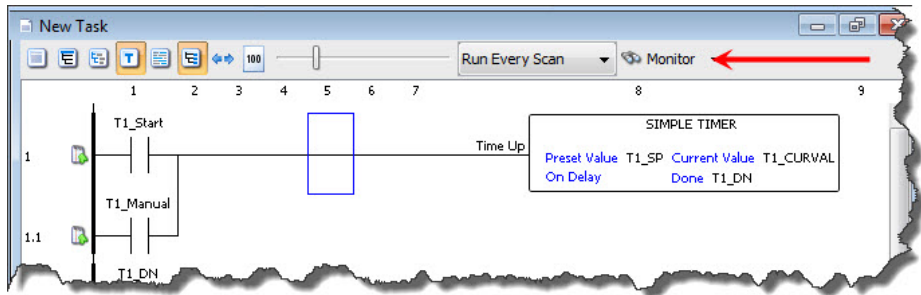

Using Data View, the Tag values can be viewed or manipulated for testing the project. The Data View window can be accessed by selecting Data View from the Tools Menu of the Main Menu.

For the Simple Timer Instruction, a Monitor button is provided that, when selected, will load the tags associated with the instruction into Data View.

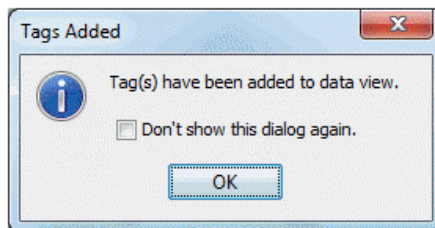
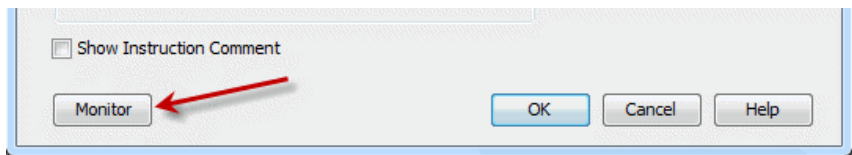

# Chapter 1: Getting Started

The tags will be placed in a separate Tab titled New Task - STMR as seen below.

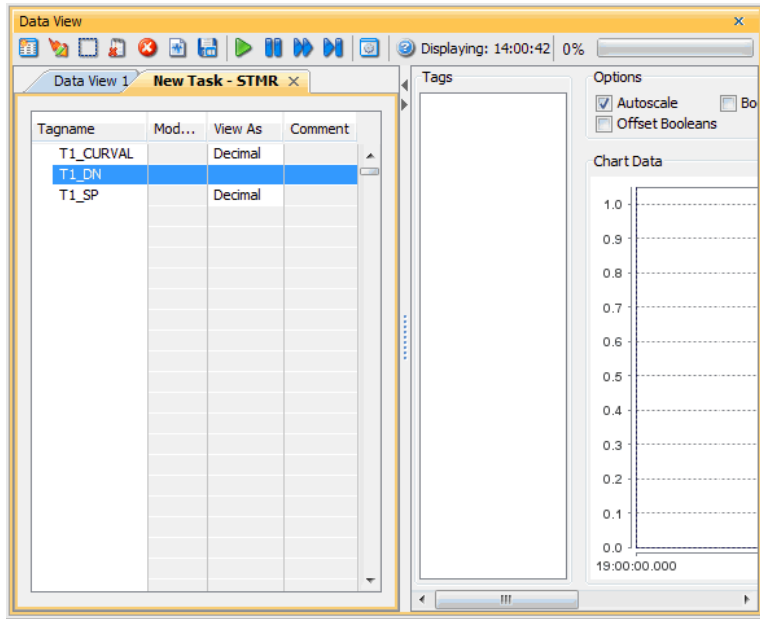

The remaining tagnames in the Ladder Logic can be added to the Data View window by clicking on a blank area in the Tagname column. This will display a drop down menu where the tags can be selected. Scroll down the list and select the tags to be added.

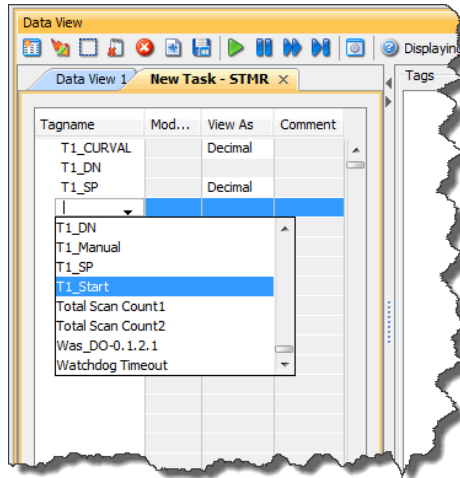

Once all of the tag names have been added, they can now be monitored and manipulated. See the Data View help file topic for additional details if needed.



**NOTE:** Force must be enabled for a Tag in the Tag Database before Force can be used in Data View.

Tag Database

Tags to show in the Editor

Show All  Discrete Inputs  Analog Inputs  Integers  System Data  Booleans  <enter text>

Invert  Discrete Outputs  Analog Outputs  Floats  Strings  Unused I/O  <enter text>

Module Status  Structures  Search Tag Names

Editor

| Name        | Type            | Forceable                           | Init Forced              | Init Force Value         |
|-------------|-----------------|-------------------------------------|--------------------------|--------------------------|
| DO-0.1.2.13 | Discrete Output | <input type="checkbox"/>            | <input type="checkbox"/> | <input type="checkbox"/> |
| DO-0.1.2.14 | Discrete Output | <input type="checkbox"/>            | <input type="checkbox"/> | <input type="checkbox"/> |
| DO-0.1.2.15 | Discrete Output | <input type="checkbox"/>            | <input type="checkbox"/> | <input type="checkbox"/> |
| DO-0.1.2.16 | Discrete Output | <input type="checkbox"/>            | <input type="checkbox"/> | <input type="checkbox"/> |
| T1_CURVAL   | Integer, 32 Bit | <input type="checkbox"/>            | <input type="checkbox"/> | <input type="checkbox"/> |
| T1_DN       | Boolean         | <input checked="" type="checkbox"/> | <input type="checkbox"/> | <input type="checkbox"/> |
| T1_SP       | Integer, 32 Bit | <input type="checkbox"/>            | <input type="checkbox"/> | <input type="checkbox"/> |
| T1_Start    | Boolean         | <input type="checkbox"/>            | <input type="checkbox"/> | <input type="checkbox"/> |
| T1_Manual   | Boolean         | <input checked="" type="checkbox"/> | <input type="checkbox"/> | <input type="checkbox"/> |
| DO-0.1.2.1  | Discrete Output | <input type="checkbox"/>            | <input type="checkbox"/> | <input type="checkbox"/> |

Add Tags Delete Tags

Data View

Forceable Tags Data View 1 New Task-STMR

| Tagname   | Modbus Address | View As | Comment |
|-----------|----------------|---------|---------|
| T1_DN     |                |         |         |
| T1_Manual |                |         |         |
|           |                |         |         |
|           |                |         |         |
|           |                |         |         |

# SPECIFICATIONS

---



## In This Chapter...

|   |             |
|---|-------------|
| Overview .....  | 2-6         |
| Hardware.....   | 2-6         |
| <b>P1000 Power Supplies.....</b>                          | <b>2-7</b>  |
| P1-01AC and P1-02AC Power Supplies .....                  | 2-7         |
| P1-01AC Power Supply.....                                 | 2-8         |
| P1-02AC Power Supply .....                                | 2-9         |
| Power Connections.....                                    | 2-10        |
| Grounding.....  | 2-10        |
| P1-01DC Power Supply .....                                | 2-11        |
| Power Connections.....                                    | 2-12        |
| Grounding.....  | 2-12        |
| Productivity®1000 Alternate Power Supply Connection ..... | 2-13        |
| <b>Productivity® 1000 P1-412 CPU Module.....</b>          | <b>2-14</b> |
| P1-412 Specifications.....                                | 2-14        |
| P1-412 General Specifications.....                        | 2-15        |
| P1-412 Module Faceplate Layout .....                      | 2-16        |
| P1-412 Communication Ports .....                          | 2-17        |
| P1-412 USB-C Programming Port.....                        | 2-17        |
| P1-412 Ethernet Port.....                                 | 2-18        |
| P1-412 microSD Slot.....                                  | 2-19        |
| P1-412 RS-232 Port.....                                   | 2-20        |
| P1-412 RS-485 Port.....                                   | 2-21        |
| <b>Productivity® 1000 P1-540 CPU Module .....</b>         | <b>2-22</b> |
| P1-540 Specifications.....                                | 2-22        |
| P1-540 General Specifications.....                        | 2-23        |
| P1-540 Module Faceplate Layout .....                      | 2-24        |

## Table of Contents

---

|  |             |
|--|-------------|
| P1-540 Battery .....   | 2-25        |
| P1-540 Communication Ports .....                             | 2-26        |
| P1-540 microUSB Programming Port .....                       | 2-26        |
| P1-540 Ethernet Port .....                                   | 2-27        |
| P1-540 microSD Slot .....                                    | 2-28        |
| P1-540 RS-232 Port .....                                     | 2-29        |
| P1-540 RS-485 Port .....                                     | 2-30        |
| <b>Productivity1000 P1-550 CPU Module .....</b>              | <b>2-31</b> |
| P1-550 Specifications .....                                  | 2-31        |
| P1-550 Module Faceplate Layout .....                         | 2-33        |
| P1-550 Battery .....   | 2-34        |
| P1-550 Communication Ports .....                             | 2-35        |
| P1-550 microUSB Programming Port .....                       | 2-35        |
| P1-550 Ethernet Port .....                                   | 2-36        |
| P1-550 microSD Slot .....                                    | 2-37        |
| P1-550 RS-232 Port .....                                     | 2-38        |
| P1-550 RS-485 Port .....                                     | 2-39        |
| <b>Productivity<sup>®</sup> 1000 P1-622 CPU Module .....</b> | <b>2-40</b> |
| P1-622 Specifications .....                                  | 2-40        |
| P1-622 General Specifications .....                          | 2-41        |
| P1-622 Module Faceplate Layout .....                         | 2-42        |
| P1-622 External Power Terminal .....                         | 2-43        |
| P1-622 Communication Ports .....                             | 2-44        |
| P1-622 USB-C Programming Port .....                          | 2-44        |
| P1-622 Ethernet Port .....                                   | 2-45        |
| P1-622 microSD Slot .....                                    | 2-46        |
| P1-622 RS-232 Port .....                                     | 2-47        |
| P1-622 RS-485 Port .....                                     | 2-48        |
| <b>Productivity<sup>®</sup> 1000 Mini PLC Overview .....</b> | <b>2-49</b> |
| P1-M401 PLC Modules .....                                    | 2-50        |
| P1-M412 PLC Modules .....                                    | 2-50        |
| P1-M622 PLC Modules .....                                    | 2-50        |
| P1 Mini PLC Features .....                                   | 2-51        |
| Communication Ports .....                                    | 2-53        |

|   |             |
|---|-------------|
| microSD Slot .....  | 2-53        |
| USB Programming Port .....                                  | 2-53        |
| RS-232 Port .....   | 2-54        |
| RS-485 Port .....   | 2-55        |
| P1-M412 Ethernet Port.....                                  | 2-56        |
| P1-M622 Ethernet Port.....                                  | 2-57        |
| <b>P1 Mini PLC Specifications.....</b>                      | <b>2-58</b> |
| P1-Mxxx PLC Common Specifications.....                      | 2-58        |
| P1 Mini PLC Insulation Requirements .....                   | 2-61        |
| Input to Output Insulation .....                            | 2-61        |
| Output to Output Insulation .....                           | 2-61        |
| Additional Basic Insulation Examples.....                   | 2-61        |
| Input and Output Derating Charts (P1-Mxxx-12DRS only) ..... | 2-61        |
| <b>Remote Slave Module.....</b>                             | <b>2-64</b> |
| P1-RX Remote Slave Module.....                              | 2-64        |
| P1-RX Power Terminal.....                                   | 2-65        |
| P1-RX Remote I/O Example.....                               | 2-65        |
| P1-RX Setting Remote Slave Address .....                    | 2-66        |
| P1-RX Remote I/O Port .....                                 | 2-67        |
| <b>I/O Modules Overview .....</b>                           | <b>2-68</b> |
| <b>Discrete I/O Modules.....</b>                            | <b>2-69</b> |
| Discrete Input Modules.....                                 | 2-69        |
| Discrete Output Modules.....                                | 2-69        |
| <b>Discrete Combo I/O Modules.....</b>                      | <b>2-70</b> |
| Discrete Combo Input/Output Modules .....                   | 2-70        |
| <b>I/O Modules Installation .....</b>                       | <b>2-70</b> |
| <b>P1-08SIM Input Simulator Module.....</b>                 | <b>2-71</b> |
| <b>P1-08ND-TTL DC Input.....</b>                            | <b>2-72</b> |
| Wiring Diagrams.....  | 2-74        |
| <b>P1-08ND3 Sinking/Sourcing DC Input .....</b>             | <b>2-75</b> |
| Wiring Diagrams .....                                       | 2-77        |
| <b>P1-16ND3 Sinking/Sourcing DC Input.....</b>              | <b>2-78</b> |
| Wiring Diagrams.....  | 2-80        |

## Table of Contents

---

|  |       |
|--|-------|
| P1-08NE3 AC/DC Sinking/Sourcing Input .....            | 2-81  |
| Wiring Diagrams .....                                  | 2-83  |
| P1-16NE3 AC/DC Sinking/Sourcing Input .....            | 2-84  |
| Wiring Diagrams .....                                  | 2-86  |
| P1-08NA AC Input .....                                 | 2-87  |
| Wiring Diagrams .....                                  | 2-89  |
| P1-08TD-TTL DC Output .....                            | 2-90  |
| Wiring Diagrams .....                                  | 2-92  |
| P1-08TD1 Sinking DC Output .....                       | 2-93  |
| Wiring Diagrams .....                                  | 2-95  |
| P1-08TD2 Sourcing DC Output .....                      | 2-96  |
| Wiring Diagrams .....                                  | 2-98  |
| P1-15TD1 Sinking DC Output .....                       | 2-99  |
| Wiring Diagrams .....                                  | 2-101 |
| P1-15TD2 Sourcing DC Output .....                      | 2-102 |
| Wiring Diagrams .....                                  | 2-104 |
| P1-08TA AC Output .....                                | 2-105 |
| Wiring Diagrams .....                                  | 2-107 |
| P1-04TEPS Isolated Relay (SSR) Output .....            | 2-108 |
| Wiring Diagrams .....                                  | 2-110 |
| P1-04TRS Isolated Relay .....                          | 2-111 |
| Wiring Diagrams .....                                  | 2-113 |
| P1-08TRS Isolated Relay .....                          | 2-114 |
| Wiring Diagrams .....                                  | 2-116 |
| P1-16TR Relay Output .....                             | 2-117 |
| Wiring Diagrams .....                                  | 2-119 |
| P1-12CDRS Discrete Input / Isolated Relay Output ..... | 2-120 |
| P1-12CDRS Insulation Requirements .....                | 2-122 |
| Input to Output Insulation .....                       | 2-122 |
| Output to Output Insulation .....                      | 2-122 |
| Additional Basic Insulation Examples .....             | 2-122 |
| Input and Output Derating .....                        | 2-122 |
| Wiring Diagrams .....                                  | 2-123 |

|  |       |
|--|-------|
| P1-15CDD1 Input/Output .....               | 2-124 |
| Wiring Diagrams .....                      | 2-126 |
| P1-15CDD2 Input/Output .....               | 2-127 |
| Wiring Diagrams .....                      | 2-129 |
| P1-16CDR Discrete Input/ Relay Output..... | 2-130 |
| Wiring Diagrams .....                      | 2-132 |

# Overview

## Hardware

The Productivity®1000 system of components is designed to combine practical PLC features in a compact and expandable design, with a simple-to-use philosophy. The Productivity1000 PLC can expand its local I/O capacity by connecting additional local I/O modules or by connecting to remote I/O through the P1-RX Remote Slave module. The Productivity1000 PLC system does not require a mounting base. The Productivity1000 PLC and I/O modules are connected together via an expansion port on the right side of the PLC case. A wide variety of I/O modules is available for flexible and optimal system configuration.

The Productivity1000 PLC is supported by the robust and powerful Productivity Suite programming software, designed with an easy-to-use instruction set that covers all applications suitable for this class of PLC. The CPU stores and executes the user-designed program.



## P1000 Power Supplies

Three power supplies are available for the P1000, providing either AC or DC source power choices. P1-01AC and P1-02AC provide two choices for AC sourcing of power, 16 W and 26 W respectively, and the P1-01DC provides 16 W power from a DC source.

### P1-01AC and P1-02AC Power Supplies

These AC power supplies require an external 100–240 VAC source and provide isolated 24 VDC to the Productivity1000 P1-540 or P1-550 CPU system.

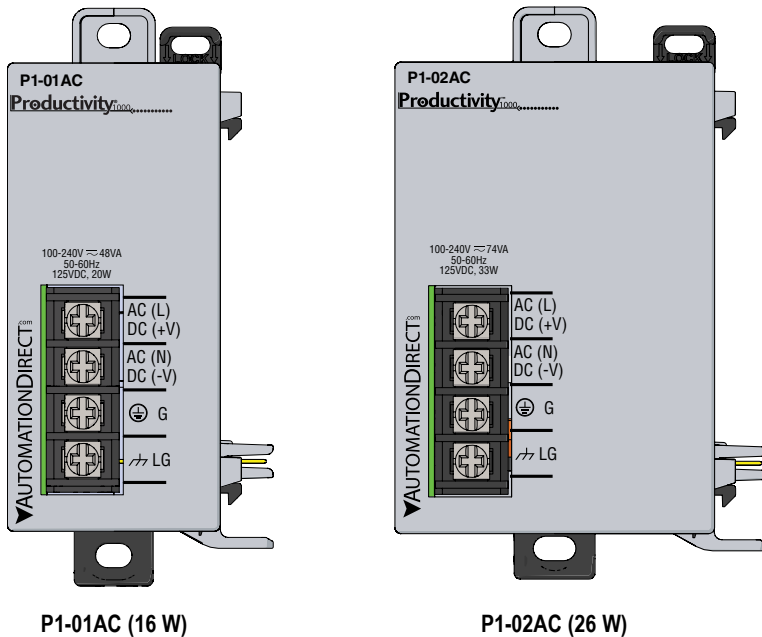

| Terminal Block Specifications |  |
|-------------------------------|--|
| Number of positions           | 4 screw terminals  |
| Wire Range                    | 22–12 AWG (0.324 to 3.31 mm <sup>2</sup> )<br>Solid / stranded conductor<br>3/64 in (1.2 mm) insulation max.<br>1/4 in (6–7 mm) strip length |
| Conductors                    | Use copper conductors, 75°C or equivalent  |
| Screw Driver                  | 1/4 in (6.5 mm) maximum  |
| Screw Size                    | M3   |
| Screw Torque                  | 7–9 lb·in (0.882–1.02 N·m)   |

\*Recommended screw driver P/N: TW-SD-MSL-2

### P1-01AC Power Supply

The P1-01AC Universal Power Supply provides isolated, 16 W of power to the Productivity1000 system from an external 100–240 VAC or 125VDC source.

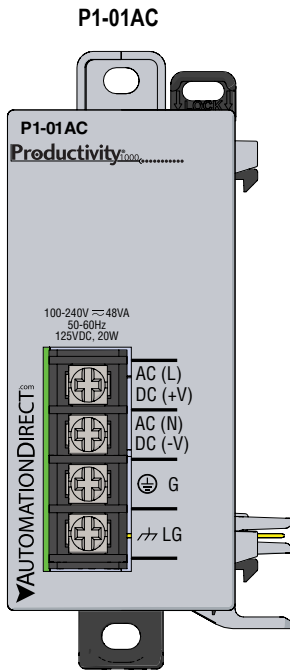

**IMPORTANT!**



#### Hot-Swapping Information

**Note:** This device cannot be Hot Swapped.



**NOTE:** P1-01AC provides 16W of power to support a CPU and up to 8 expansion modules.

### User Specifications

|  |  |
|--|--|
| Input Voltage Range (Tolerance)  | 100–240 VAC (-15% / +10%)<br>125VDC (-15% / +20%)                    |
| Rated Operating Frequency  | 50 to 60Hz with $\pm 5\%$ tolerance                                  |
| Maximum Input Power  | 48 VA (AC) 20 W (DC)   |
| Cold Start Inrush Current  | 21 A   |
| Maximum Inrush Current (Hot Start)                                     | 21 A   |
| Input Fuse Protection (Internal)                                       | Micro fuse 250 V, 1 A<br>Non-replaceable                             |
| Efficiency   | 75%  |
| Output Voltage   | 24 VDC, 0.67 A   |
| Maximum Output Power   | 16 W   |
| Isolated User 24 VDC Output  | None   |
| Output Protection for Over Current, Over Voltage, and Over Temperature | Self resetting   |
| Under Input Voltage Lock-out   | 40–75 VAC - 24VDC On @ 76.15 VAC<br>55–99 VDC - 24VDC On @ 100.2 VDC |
| Input Transient Protection   | Varistor, plus input choke and filter                                |
| Operating Design Life  | 10 years at full load at 40°C ambient and<br>5 years at 60°C ambient |
| Maximum Module Count   | Up to 8 modules  |

### General Specifications

|                                |  |
|--------------------------------|--|
| Operating Air Temperature      | 0°C– 60°C (32°F–140°F)   |
| Storage Temperature            | -20°C–70°C (-4°F–158°F)  |
| Humidity                       | 5 to 95% (non-condensing)  |
| Environmental Air              | No corrosive gases permitted   |
| Vibration                      | IEC60068-2-6 (Test Fc)   |
| Shock                          | IEC60068-2-27 (Test Ea)  |
| Insulation Resistance          | >10 M $\Omega$ @ 500 VDC   |
| Heat Dissipation               | 5000 mW  |
| Enclosure Type                 | Open equipment   |
| Voltage Withstand (dielectric) | 2100 VDC applied for 2 s   |
| Module Location                | Power supply latches to CPU in the module stacking Productivity1000 system.  |
| Weight                         | 146 g (5.1 oz)   |
| Agency Approvals               | UL 61010-1 and UL 61010-2-201 file E139594,<br>Canada and USA<br>CE (EN 61131-2 EMC, EN 61010-1 and<br>EN 61010-2-201 Safety)* |

\*See CE Declaration of Conformity for details.

## P1-02AC Power Supply

The P1-02AC Universal Power Supply provides isolated, 26 W power to the Productivity1000 system from an external 100–240 VAC or 125 VDC source.

### P1-02AC

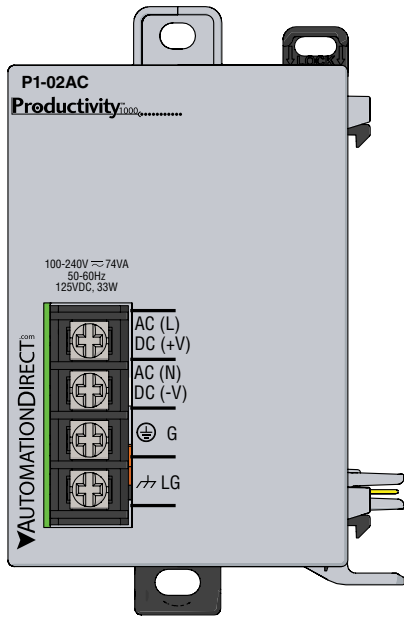

### User Specifications

|  |  |
|--|--|
| Input Voltage Range (Tolerance)  | 100–240 VAC (-15% / +10%)<br>125 VDC (-15% / +20%)                     |
| Rated Operating Frequency  | 50 to 60 Hz with ±5% tolerance   |
| Maximum Input Power  | 74 VA (AC) 33 W (DC)   |
| Cold Start Inrush Current  | 21 A   |
| Maximum Inrush Current (Hot Start)                                     | 21 A   |
| Input Fuse Protection (Internal)                                       | Micro fuse 250 V, 2 A non-replaceable                                  |
| Efficiency   | 81%  |
| Output Voltage   | 24 VDC, 1.08 A   |
| Maximum Output Power   | 26 W   |
| Isolated User 24 VDC Output  | None   |
| Output Protection for Over Current, Over Voltage, and Over Temperature | Self resetting   |
| Under Input Voltage Lock-out   | 40–75 VAC - 24 VDC On @ 76.15 VAC<br>55–99 VDC - 24 VDC On @ 100.2 VDC |
| Input Transient Protection   | Varistor, plus input choke and filter                                  |
| Operating Design Life  | 10 years at full load at 40°C ambient and<br>5 years at 60°C ambient   |
| Maximum Module Count   | Up to 15 modules   |

### IMPORTANT!



#### Hot-Swapping Information

**Note:** This device cannot be Hot Swapped.



**NOTE:** P1-02AC provides 26W of power to support a CPU and up to 15 expansion modules.

### General Specifications

|                                |  |
|--------------------------------|--|
| Operating Air Temperature      | 0°C to 60°C (32°F to 140°F)  |
| Storage Temperature            | -20°C to 70°C (-4°F to 158°F)  |
| Humidity                       | 5 to 95% (non-condensing)  |
| Environmental Air              | No corrosive gases permitted   |
| Vibration                      | IEC60068-2-6 (Test Fc)   |
| Shock                          | IEC60068-2-27 (Test Ea)  |
| Insulation Resistance          | >10 MΩ @ 500 VDC   |
| Heat Dissipation               | 6200 mW  |
| Enclosure Type                 | Open equipment   |
| Voltage Withstand (dielectric) | 2100 VDC applied for 2 s   |
| Module Location                | Power Supply latches to CPU in the module stacking Productivity1000 system.  |
| Weight                         | 164 g (5.8 oz)   |
| Agency Approvals               | UL 61010-1 and UL 61010-2-201 File E139594, Canada and USA<br>CE (EN 61131-2 EMC, EN 61010-1 and EN 61010-2-201 Safety)* |

\*See CE Declaration of Conformity for details.

## Power Connections

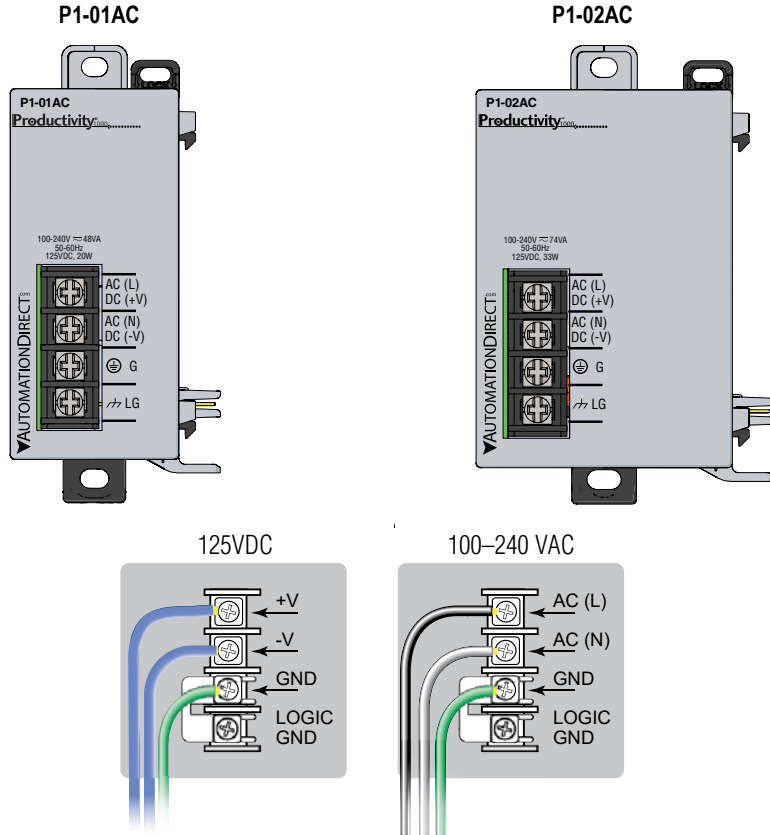

## Grounding

A good common ground reference (earth ground) is essential for proper operation of the Productivity®1000 system. One side of all control circuits, power circuits and the ground lead must be properly connected to earth ground by either installing a ground rod in close proximity to the enclosure or by connecting to the incoming power system ground. There must be a single-point ground (i.e. copper bus bar) for all devices in the enclosure that require an earth ground.

## P1-01DC Power Supply

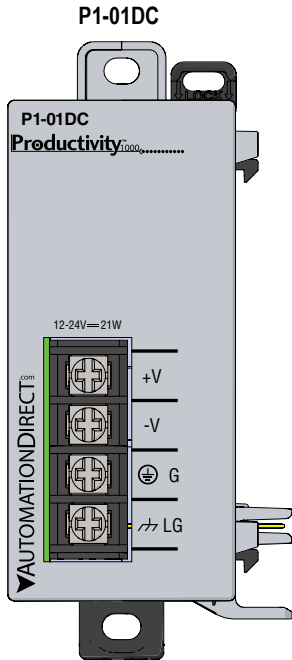

### IMPORTANT!



#### Hot-Swapping Information

**Note:** This device cannot be Hot Swapped.



**NOTE:** P1-01DC provides 16W of power to support a CPU and up to 8 expansion modules.

### P1-01DC User Specifications

|   |   |
|---|---|
| Input Voltage Range (Tolerance)                                       | 12–24 VDC (-10% / +20% at 60°C)   |
| Maximum Input Power   | 21 W  |
| Cold Start Inrush Current   | 34 A  |
| Maximum Inrush Current (Hot Start)                                    | 34 A  |
| Input Fuse Protection (Internal)                                      | Micro fuse 250 V, 4 A, non-replaceable  |
| Efficiency  | 75%   |
| Output  | 24 VDC, 0.67 A  |
| Maximum Output Power  | 16 W  |
| Isolated User 24VDC Output  | None  |
| Output Protection for Over Current, Over Voltage and Over Temperature | Positive Temperature Coefficient (PTC) resettable fuse, resets when load removed. |
| Under Input Voltage Lock-out  | < 9 VDC   |
| Over Input Voltage Lock-out   | None  |
| Input Transient Protection  | Varistor, plus input choke and filter   |
| Operating Design Life   | 10 years at full load at 40°C (104°F) ambient and 5 years at 60°C (140°F) ambient |
| Maximum Module Count  | Up to 8 modules   |

### P1-01DC General Specifications

|                                |  |
|--------------------------------|--|
| Operating Temperature          | 0°C to 60°C (32°F to 140°F)  |
| Storage Temperature            | -20°C to 70°C (-4°F to 158°F)  |
| Humidity                       | 5 to 95% (non-condensing)  |
| Environmental Air              | No corrosive gases permitted   |
| Vibration                      | IEC60068-2-6 (Test Fc)   |
| Shock                          | IEC60068-2-27 (Test Ea)  |
| Insulation Resistance          | >10 MΩ @ 500 VDC   |
| Heat Dissipation               | 5 W  |
| Enclosure Type                 | Open equipment   |
| Voltage Withstand (dielectric) | 750 VDC applied for 2 s  |
| Module Location                | Power supply slot in a Productivity1000 system.  |
| Weight                         | 146 g (5.15 oz)  |
| Agency Approvals               | UL 61010-1 and UL 61010-2-201 File E139594, Canada and USA<br>CE (EN 61131-2 EMC, EN 61010-1 and EN 61010-2-201 Safety)* |

\*See the Declaration of Conformity for details.

### Power Connections

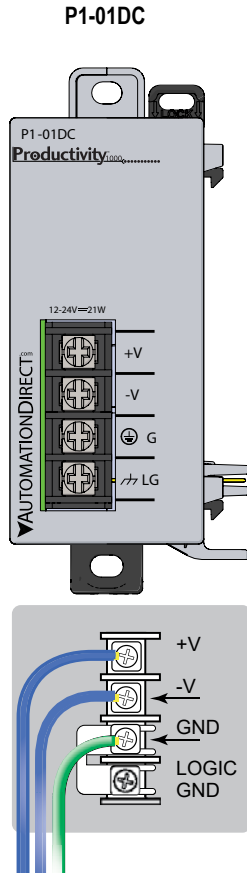

### Grounding

A good common ground reference (earth ground) is essential for proper operation of the Productivity1000 system. One side of all control circuits, power circuits and the ground lead must be properly connected to earth ground by either installing a ground rod in close proximity to the enclosure or by connecting to the incoming power system ground. There must be a single-point ground (i.e., copper bus bar) for all devices in the enclosure that require an earth ground.

## Productivity® 1000 Alternate Power Supply Connection

All Productivity1000 CPUs require 24 VDC input power. When using an alternative 24 VDC power source, connect power supply wiring to the bottom removable terminal block as shown below. Power to the P1-RX and connected modules will be supplied by **EITHER** a P1 power supply module connected to the left of the P1-RX **OR** by an external 24VDC power supply connected to the terminals at the bottom of the CPU. Only one of these sources shall be connected.

P1 power supply modules:

- P1-01AC: AC Input 85–132 / 170–264 VAC, 16 W (power for CPU and up to 8 modules)
- P1-02AC: AC Input 85–132 / 170–264 VAC, 26 W (power for CPU and up to 15 modules)
- P1-01DC: DC Input 12–24 VDC, 16 W (power for CPU and up to 8 modules)
- The LG and minus terminals on the external power supply connection are internally shorted.
- Use separate 24 VDC supplies for the CPU and inductive loads to keep the CPU power clean and free of voltage spikes caused by switching inductive loads

Alternate external power connector located on CPU bottom face is a removable connector for ease of wire termination.

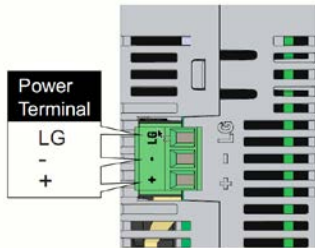

| Pin | Signal   |
|-----|----------|
| LG  | Ground   |
| -   | 24 VDC - |
| +   | 24 VDC + |

\* Recommended fuse: 2 A slow blow

Removable connector included. Spare connectors available (part no. PCON-KIT).

| Removable Terminal Block Specifications |   |
|---|---|
| Part Number                             | PCON-KIT (Includes power terminal block)                  |
| Number of Positions                     | 3 screw terminals   |
| Pitch                                   | 3.5 mm  |
| Wire Range                              | 28–16 AWG solid conductor<br>28–16 AWG stranded conductor |
| Screw Driver                            | 0.125 inch (3.175 mm) maximum                             |
| Screw Size                              | M2  |
| Screw Torque                            | 1.7 lb-in (0.4 N·m)                                       |



**NOTE:** If you do not use a Productivity1000 power supply (P1-01AC, P1-02AC or P1-01DC), then use a power supply that has transformer isolation. Use separate 24 VDC power supplies for the CPU and inductive loads to keep the CPU power clean and free of voltage spikes caused by switching solenoids, motors and relay coils.

# Productivity<sup>®</sup>1000 P1-412 CPU Module

## P1-412 Specifications



P1-412



### IMPORTANT!

#### Hot-Swapping Information

**Note:** This device cannot be Hot Swapped.



**NOTE:** The most recent Productivity Suite software and firmware versions may be required to support new modules and new features.



**NOTE:** If you do not use one of the Productivity1000 power supplies (P1-01AC, P1-02AC or P1-01DC), then use a power supply that has transformer isolation. Use separate 24 VDC supplies for the CPU and inductive loads to keep the CPU power clean and free of voltage spikes caused by switching solenoids, motors, or relay coils.

### CPU Specifications

|                                       |   |   |
|---------------------------------------|---|---|
| User Memory                           | 32 MB (includes program, data and documentation)  |   |
| Memory Type                           | Flash and RAM   |   |
| Retentive Memory                      | 27 kB   |   |
| Scan Time                             | 1.7 ms (1K Boolean, 128 I/O)  |   |
| External Power Required               | 24 VDC ±2% @ 5 W<br>plus 1.25 W per additional I/O module   |   |
| Protection Circuit (External)*        | Edison S5061-R, Time Delay, 1 A Fuse (8 I/O Modules)  |   |
| Communications;<br>4 Integrated Ports | <b>USB IN:</b> Programming, monitoring, debug, firmware<br><b>Ethernet:</b> (10/100 Mbps Ethernet) programming, monitoring, debug, firmware, email SMTP client, MQTT/MQTTS, Modbus TCP Client (8 servers) and server (4 clients), EtherNet/IP scanner (4) and adapter (2), custom protocol over Ethernet, ProNET.<br><b>RS-232:</b> (RJ12, 1200–115.2 K baud) ASCII, Modbus<br><b>RS-485:</b> Removable terminal included (1200–115.2 K baud) ASCII, Modbus RTU |   |
| Data Logging                          | microSD card slot   |   |
| Hardware Limits of System             | 128 hardware I/O points: All 8 (16-point I/O modules)   |   |
| Instruction Types                     | Application functions<br>Array functions<br>Counters/timers<br>Communications<br>Data handling<br>Drum sequencers<br>Math Functions   | PID<br>Program control<br>String functions<br>System functions<br>Contacts<br>Coils |
| Real-time Clock Accuracy              | N/A   |   |

\* If an external 24 VDC power supply is used then install protection element such as Edison S5061-R, time delay, 1 A fuse

# P1-412 Module (continued)

## P1-412 General Specifications

| General Specifications    |  |
|---------------------------|--|
| Operating Air Temperature | 0°C to 60°C (32°F to 140°F)  |
| Storage Temperature       | -20°C to 70°C (-4°F to 158°F)  |
| Humidity                  | 5 to 95% (non-condensing)  |
| Altitude                  | 2000 meters max.   |
| Pollution Degree          | 2  |
| Environmental Air         | No corrosive gases permitted   |
| Vibration                 | IEC60068-2-6 (Test Fc)   |
| Shock                     | IEC60068-2-27 (Test Ea)  |
| Overvoltage Category      | II   |
| Heat Dissipation          | 2125 mW  |
| Enclosure Type            | Open equipment   |
| Module Location           | Controller connector on the side of the power supply in a Productivity1000 system.                                       |
| Weight                    | 82 g (2.9 oz)  |
| Agency Approvals*         | UL 61010-1 and UL 61010-2-201 File E139594, Canada and USA<br>CE (EN 61131-2 EMC, EN 61010-1 and EN 61010-2-201 Safety)* |

\*Note: See CE Declaration of Conformance for Details.

## P1-412 Module Faceplate Layout

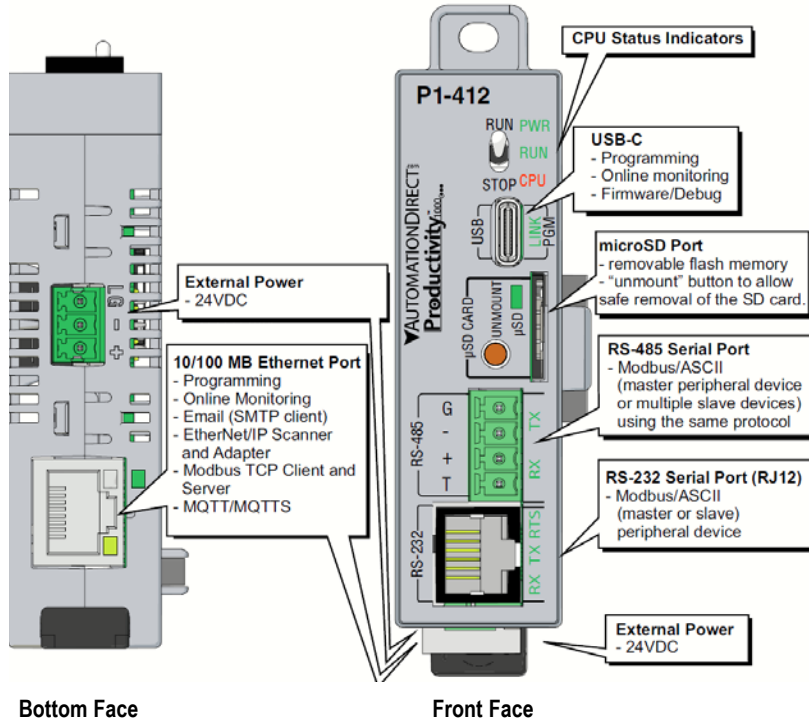

### CPU Run/Stop Switch Specifications

|               |   |
|---------------|---|
| RUN position  | Executes user program, run-time edits possible              |
| STOP position | Does not execute user program, normal program load position |

### CPU Status Indicators

|     |   |
|-----|---|
| PWR | Green LED is illuminated when power is ON                                       |
| RUN | Green LED is illuminated when CPU is in RUN mode                                |
| CPU | Red LED is illuminated during power ON reset, power down, or watch-dog time-out |

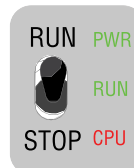

## P1-412 Communication Ports

The P1-412 has several communications ports. The following pages cover the specifications and pin-out diagrams.

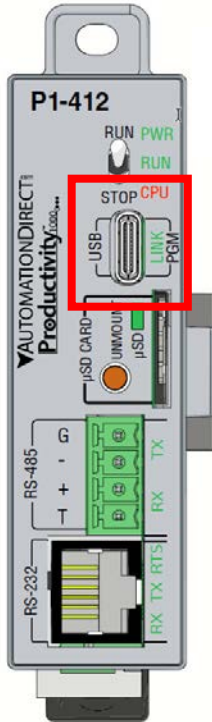

## P1-412 USB-C Programming Port

Used exclusively for connecting to a PC running the Productivity Suite programming software.

| USB-C Slave Input Specifications |  |
|----------------------------------|--|
| Port Name                        | USB-C  |
| Description                      | Standard USB-C Slave input for programming and on-line monitoring, with built-in surge protection. Not compatible with older full speed USB devices. |
| Transfer Rate                    | 480 Mbps   |
| Port Status LED                  | Green LED is illuminated when LINK is established to programming software.   |
| Cables                           | USB Type A to MicroUSB Type C:<br>6 ft cable part # USB-CBL-AC6  |



## P1-412 microSD Slot

Used for data logging.

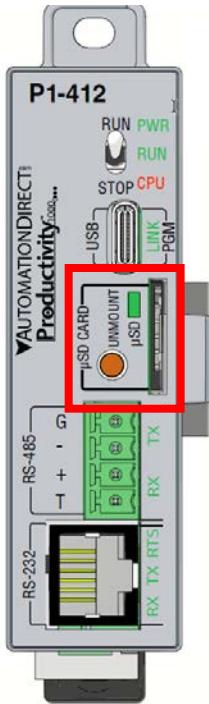

P1-412

| microSD Specifications               |   |         |         |         |
|--------------------------------------|---|---------|---------|---------|
| Port Name                            | microSD   |         |         |         |
| Description                          | Standard microSD socket for data logging                |         |         |         |
| Maximum Card Capacity                | 32GB SDHC   |         |         |         |
| Transfer Rate (Class 4 memory card)* | Mbps  | Minimum | Typical | Maximum |
|                                      | Read  | 14.3    | 14.4    | 14.6    |
|                                      | Write   | 4.8     | 4.9     | 5.1     |
| Port Status LED                      | Green LED is illuminated when card is inserted/detected |         |         |         |

\*Supported microSD MICSD-16G

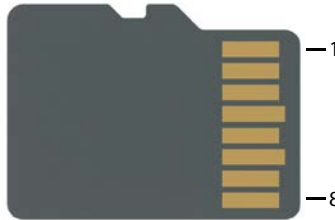

| Pin | SD      |
|-----|---------|
| 1   | DAT2    |
| 2   | CD/DAT3 |
| 3   | CMD     |
| 4   | VDD     |
| 5   | CLK     |
| 6   | VSS     |
| 7   | DAT0    |
| 8   | DAT1    |

Note: Card not included with unit.

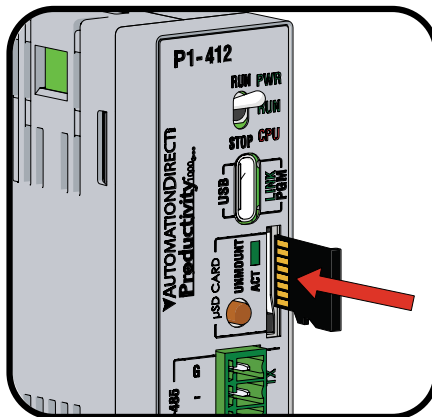

## P1-412 RS-232 Port



RJ-12 style connector used for the following:

- Modbus RTU Master connections
- Modbus RTU Slave connections
- ASCII full or half duplex communications
- Custom Protocol Incoming and Outgoing communications

### RS-232 Specifications

|                                 |   |
|---------------------------------|---|
| Port Name                       | RS-232  |
| Description                     | Non-isolated RS-232 DTE port connects the CPU as a Modbus/ASCII master or slave to a peripheral device. Includes ESD and built-in surge protection. |
| Data Rates                      | Selectable, 1200, 2400, 4800, 9600, 19200, 33600, 38400, 57600, and 115200 baud.  |
| +5V Cable Power Source          | 210 mA maximum at 5 V, ±5%. Reverse polarity and overload protected.  |
| TXD                             | RS-232 transmit output  |
| RXD                             | RS-232 receive input  |
| RTS                             | Handshaking output for modem control  |
| GND                             | Logic ground  |
| Maximum Output Load (TXD/RTS)   | 3 kΩ, 1000 pf   |
| Minimum Output Voltage Swing    | ±5 V  |
| Output Short Circuit Protection | ±15 mA  |
| Port Status LED                 | Green LED is illuminated when active for TXD, RXD and RTS.  |
| Cable Options                   | EA-MG-PGM-CBL<br>D2-DSCBL<br>USB-RS232-1 with D2-DSCBL<br>FA-CABKIT<br>FA-ISOCAN for converting RS-232 to isolated RS-485                           |

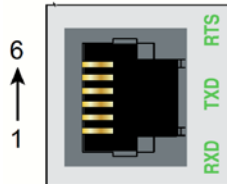

6-Pin RJ12 Female Modular Connector

| Pin | Label | Signal        |
|-----|-------|---------------|
| 6   | GND   | Logic Ground  |
| 5   | RTS   | RS-232 Output |
| 4   | TXD   | RS-232 Output |
| 3   | RXD   | RS-232 Input  |
| 2   | +5V   | 210mA Maximum |
| 1   | GND   | Logic Ground  |

### P1-412 RS-485 Port

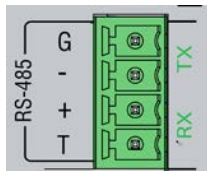
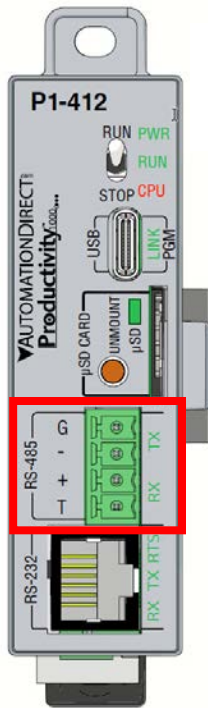

| Pin | Signal      |
|-----|-------------|
| G   | GND         |
| -   | TXD-/RXD-   |
| +   | TXD+/RXD+   |
| T   | Termination |



Removable connector included. Spare connectors available (part no. P3-RS485CON-1).

A 4-pin removable terminal block used for the following:

- Modbus RTU Master connections
- Modbus RTU Slave connections
- ASCII Incoming and Outgoing communications
- Custom Protocol Incoming and Outgoing communications

### RS-485 Port Specifications

| Port Name  | RS-485   |
|--|--|
| Description  | Non-isolated RS-485 port connects the CPU as a Modbus/ASCII master or slave to a peripheral device. Includes ESD/EFT protection and automatic echo cancellation when transmitter is active |
| Data Rates   | Selectable, 1200, 2400, 4800, 9600, 19200, 33600, 38400, 57600, and 115200 baud  |
| TXD+/RXD+  | RS-485 transceiver high  |
| TXD-/RXD-  | RS-485 transceiver low   |
| GND  | Logic ground   |
| Input Impedance                                    | 19 kΩ  |
| Termination Resistance (TB jumper wire "T" to "+") | 120 Ω To use, add a jumper between "T" and "+". Resistor is internally connected between "T" and "-".  |
| Maximum Load                                       | 50 transceivers, 19kΩ each, 60Ω termination  |
| Output Short Circuit Protection                    | ±250 mA, thermal shut-down protection  |
| Electrostatic Discharge Protection                 | Contact ±4kV, Air ±8kV per IEC1000-4-2 Cable is installed for testing  |
| Electrical Fast Transient Protection               | ±1 kV per IEC1000-4-4  |
| Minimum Differential Output Voltage                | 1.5 V with 60Ω load  |
| Fail Safe Inputs                                   | Logic high input state if inputs are unconnected   |
| Maximum Common Mode Voltage                        | -7.5 V to 12.5 V   |
| Port Status LED                                    | Green LED illuminated when active for TXD and RXD  |
| Cable Options                                      | Go to AutomationDirect.com for RS-232 and RS-285 cables.   |

### Removable Terminal Block Specifications

|                     |   |
|---------------------|---|
| Part Number         | P3-RS485CON-1   |
| Number of Positions | 4 screw terminals   |
| Pitch               | 3.5 mm  |
| Wire Range          | 28-16 AWG solid conductor<br>28-16 AWG stranded conductor |
| Screw Driver        | 0.125 in. (3.175 mm) maximum                              |
| Screw Size          | M2  |
| Screw Torque        | 1.7 lb-in (0.4 N-m)                                       |

# Productivity<sup>®</sup>1000 P1-540 CPU Module

## P1-540 Specifications

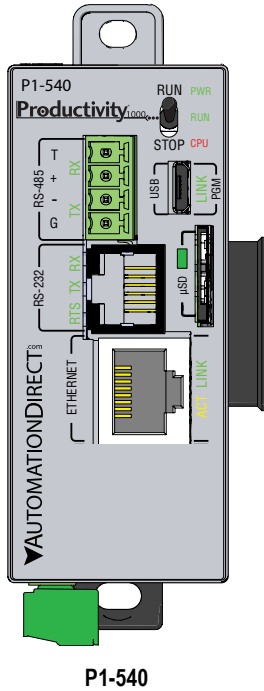

P1-540



**IMPORTANT!**

### Hot-Swapping Information

**Note:** This device cannot be Hot Swapped.



**NOTE:** The most recent Productivity Suite software and firmware versions may be required to support new modules and new features.



**NOTE:** If you do not use one of the Productivity1000 power supplies (P1-01AC, P1-02AC or P1-01DC), then use a power supply that has transformer isolation. Use different 24 VDC supplies for the CPU and inductive loads to keep the CPU power clean and free of voltage spikes caused by switching solenoids, motors, or relay coils.

### CPU Specifications

|                                       |  |   |
|---------------------------------------|--|---|
| User Memory                           | 50 MB (Includes program, data and documentation)   |   |
| Memory Type                           | Flash and battery-backed RAM   |   |
| Retentive Memory                      | 500 kB   |   |
| Scan Time                             | 1.3 ms (1K Boolean, 128 I/O)   |   |
| External Power Required               | 24 VDC $\pm 2\%$ @ 5 W<br>plus 1.25 W per additional I/O module<br>In-Rush current 35 A<br>(see page 2-5 for power supply options)<br>External fuse is required when using external power supply, the recommended fuse is Edison S5062-R, Time Delay, 2 A Fuse (8 I/O Modules)   |   |
| Communications;<br>4 Integrated Ports | USB: Programming, monitoring, debug, firmware<br>Ethernet: (10/100 Mbps Ethernet) programming, monitoring, debug, firmware, email SMTP client, MQTT, Modbus TCP Client (16 Servers) and server (16 Clients), EtherNet/IP scanner (32) and adapter (4), custom protocol over Ethernet, ProNET.<br>RS-232: (RJ12, 1200–115.2 K baud) ASCII, Modbus<br>RS-485: Removable terminal included, (1200–115.2 K baud) ASCII, Modbus RTU |   |
| Data Logging                          | microSD card slot  |   |
| Hardware Limits of System             | 240 Hardware I/O Points: All 15 (16-point I/O modules)   |   |
| Instruction Types                     | Application functions<br>Array functions<br>Counters/timers<br>Communications<br>Data handling<br>Drum sequencers<br>Math Functions  | PID<br>Program control<br>String functions<br>System functions<br>Contacts<br>Coils |
| Real-time Clock Accuracy              | $\pm 2$ s per day typical at 25°C (77°F)<br>$\pm 10$ s per day maximum at 60°C (140°F)   |   |

# Productivity® 1000 P1-540 CPU Module (continued)

## P1-540 General Specifications

| General Specifications  |   |
|---|---|
| Operating Air Temperature   | 0°C to 60°C (32°F to 140°F)   |
| Storage Temperature   | -20°C to 70°C (-4°F to 158°F)   |
| Humidity  | 5 to 95% (non-condensing)   |
| Environmental Air   | No corrosive gases permitted  |
| Vibration   | IEC60068-2-6 (Test Fc)  |
| Shock   | IEC60068-2-27 (Test Ea)   |
| Heat Dissipation  | 3810 mW   |
| Enclosure Type  | Open equipment  |
| Module Location   | Controller connector on the side of the power supply in a Productivity1000 system.                                      |
| Weight  | 136 g (4.8 oz)  |
| Agency Approvals<br>(See CE Declaration of Conformity for details.) | UL 61010-1 and UL 61010-2-201 File E139594, Canada and USA<br>CE (EN 61131-2 EMC, EN 61010-1 and EN 61010-2-201 Safety) |

## P1-540 Module Faceplate Layout

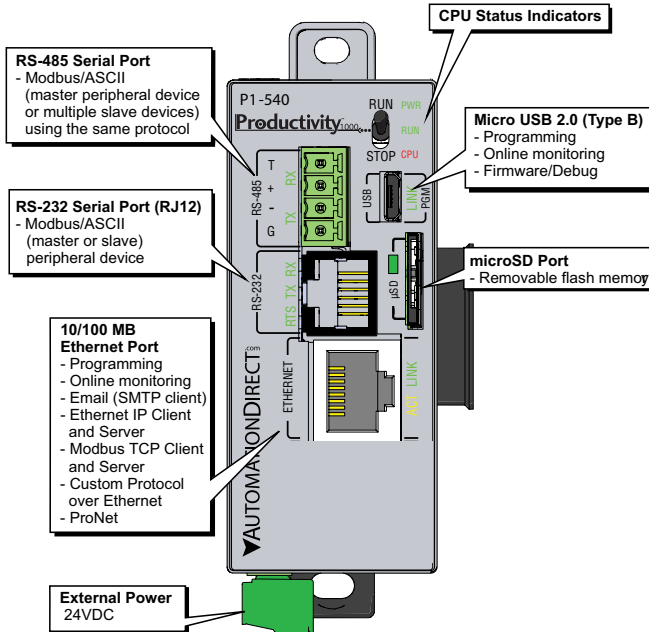

P1-540

### CPU Run/Stop Switch Specifications

|               |   |
|---------------|---|
| RUN position  | Executes user program, run-time edits possible              |
| STOP position | Does not execute user program, normal program load position |

### CPU Status Indicators

|     |   |
|-----|---|
| PWR | Green LED is illuminated when power is ON                                       |
| RUN | Green LED is illuminated when CPU is in RUN mode                                |
| CPU | Red LED is illuminated during power ON reset, power down, or watch-dog time-out |



## P1-540 Battery

A battery is included with some CPU modules, but is not installed. The battery may be installed in order to retain the time and date settings along with any tagname values that are set up as retentive.

Please note that the battery is not required for program backup.

### Step One:

Open battery compartment located on the top of the CPU and pull up to locked position.

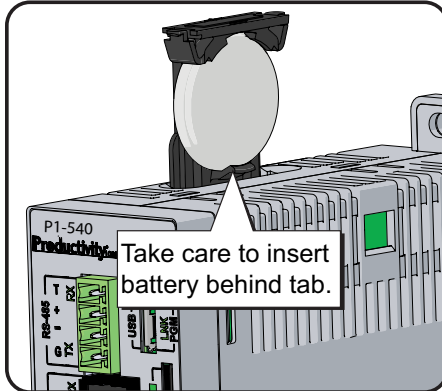
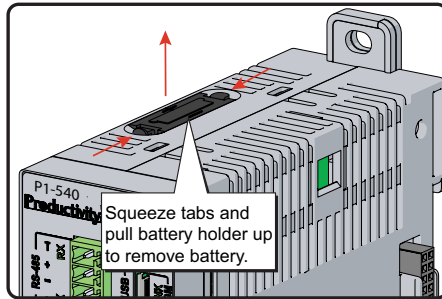

### Step Two:

Insert battery under top two tabs in battery compartment. Press and snap battery behind bottom tab then close the battery compartment.

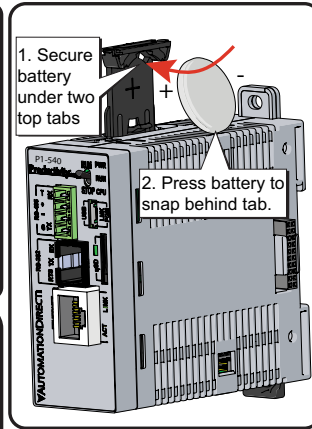

## Battery (Optional)

|          |   |
|----------|---|
| D2-BAT-1 | Coin type, 3.0 V Lithium battery, 560 mA, battery number CR2354 |
|----------|---|

*Note: Although not needed for program backup, an uninstalled battery is included with some CPU modules. Install this battery if you want the CPU to retain the Time and Date along with any Tagname values that you have set up as retentive.*

### P1-540 Communication Ports

The P1-540 has several communications ports. The following pages contain the specifications and pin-out diagrams.

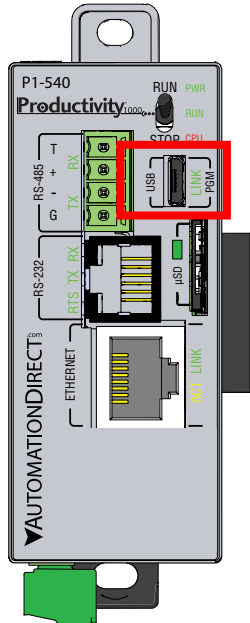

P1-540

### P1-540 microUSB Programming Port

Used exclusively for connecting to a PC running the Productivity Suite programming software.

#### Micro USB Input Specifications

|                 |   |
|-----------------|---|
| Port Name       | MicroUSB  |
| Description     | Standard MicroUSB Slave input for programming and on-line monitoring, with built-in surge protection. Not compatible with older full speed USB devices. |
| Transfer Rate   | 480 Mbps  |
| Port Status LED | Green LED is illuminated when LINK is established to programming software.  |
| Cables          | USB Type A to MicroUSB Type B:<br>6 ft cable part # USB-CBL-AMICB6<br>15 ft cable part # USB-CBL-AMICB15  |

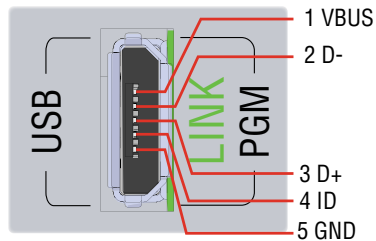

## P1-540 Ethernet Port

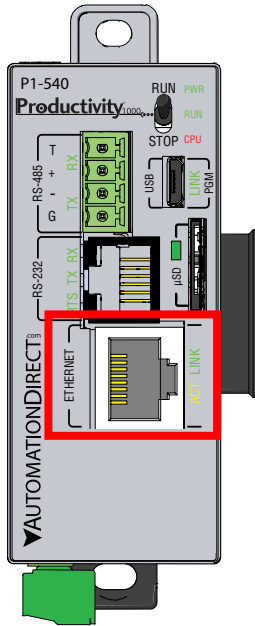

P1-540

RJ-45 style connector used for:

- Connection to a PC running the Productivity Suite programming software
- Modbus TCP Client connections (Modbus requests sent from the CPU)
- Modbus TCP Server connections (Modbus requests received by the CPU)
- EtherNet/IP (Client/Server)
- Custom Protocol over Ethernet
- ProNET
- Outgoing Email

| Ethernet Specifications |   |
|-------------------------|---|
| Port Name               | ETHERNET  |
| Description             | Standard transformer isolated Ethernet port with built-in surge protection for programming, online monitoring, Email (SMTP client), Modbus/TCP client/server connections (fixed IP or DHCP), EtherNet/IP scanner/apapter, custom protocol over Ethernet and ProNET connections. |
| Transfer Rate           | 10 Mbps and 100 Mbps (auto-crossover).  |
| Port Status LED         | LINK (Amber LED) is solid when network LINK is established. ACT (Green LED) flashes when port is active.  |

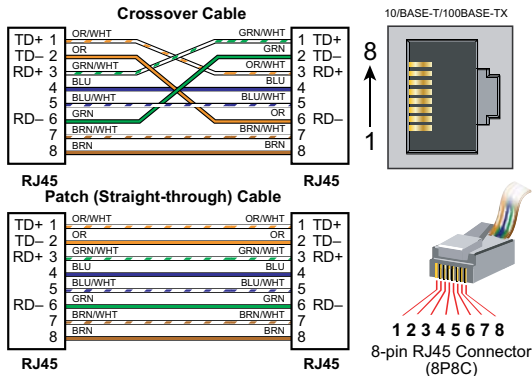

### P1-540 microSD Slot

Used for data logging.

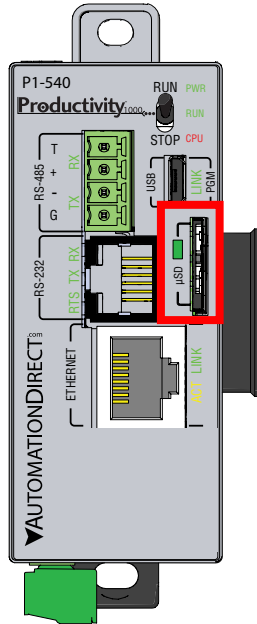

P1-540

| microSD Specifications                              |   |         |         |         |
|---|---|---------|---------|---------|
| Port Name   | microSD   |         |         |         |
| Description   | Standard microSD socket for data logging                |         |         |         |
| Maximum Card Capacity                               | 32 GB   |         |         |         |
| Transfer Rate (ADATA microSDHC Class 4 memory card) | Mbps  | Minimum | Typical | Maximum |
|   | Read  | 14.3    | 14.4    | 14.6    |
|   | Write   | 4.8     | 4.9     | 5.1     |
| Port Status LED                                     | Green LED is illuminated when card is inserted/detected |         |         |         |



| Pin | SD      |
|-----|---------|
| 1   | DAT2    |
| 2   | CD/DAT3 |
| 3   | CMD     |
| 4   | VDD     |
| 5   | CLK     |
| 6   | VSS     |
| 7   | DAT0    |
| 8   | DAT1    |

Note: Card not included with unit.

## P1-540 RS-232 Port

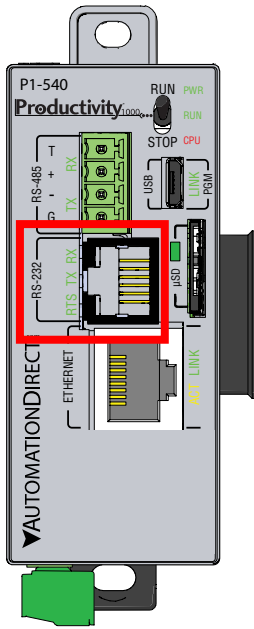

RJ-12 style connector used for:

- Modbus RTU Master connections
- Modbus RTU Slave connections
- ASCII full or half duplex communications
- Custom Protocol Incoming and Outgoing communications

### RS-232 Specifications

|                                 |  |
|---------------------------------|--|
| Port Name                       | RS-232   |
| Description                     | Non-isolated RS-232 DTE port connects the CPU as a Modbus/ASCII master or slave to a peripheral device. Includes ESD and built-in surge protection |
| Data Rates                      | Selectable, 1200, 2400, 4800, 9600, 19200, 33600, 38400, 57600, and 115200 baud  |
| +5V Cable Power Source          | 210 mA maximum at 5 V, $\pm 5\%$ . Reverse polarity and overload protected   |
| TXD                             | RS-232 Transmit output   |
| RXD                             | RS-232 Receive input   |
| RTS                             | Handshaking output for modem control   |
| GND                             | Logic ground   |
| Maximum Output Load (TXD/RTS)   | 3 k $\Omega$ , 1000 pf   |
| Minimum Output Voltage Swing    | $\pm 5$ V  |
| Output Short Circuit Protection | $\pm 15$ mA  |
| Port Status LED                 | Green LED is illuminated when active for TXD, RXD and RTS  |
| Cable Options                   | EA-MG-PGM-CBL<br>D2-DSCBL<br>USB-RS232-1 with D2-DSCBL<br>FA-CABKIT<br>FA-ISOCAN for converting RS-232 to isolated RS-485                          |

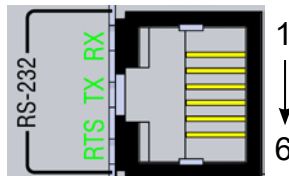

6-Pin RJ12 Female Modular Connector

| Pin | Label | Signal         |
|-----|-------|----------------|
| 1   | GND   | Logic Ground   |
| 2   | +5V   | 210 mA Maximum |
| 3   | RXD   | RS-232 Input   |
| 4   | TXD   | RS-232 Output  |
| 5   | RTS   | RS-232 Output  |
| 6   | GND   | Logic Ground   |

## P1-540 RS-485 Port

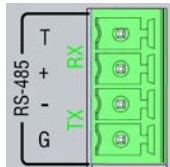
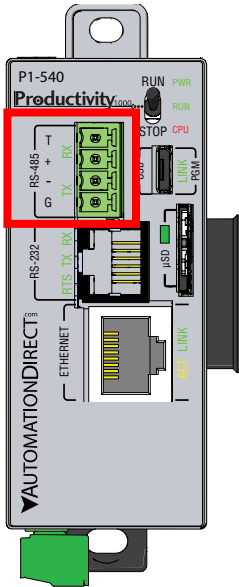

| Pin | Signal      |
|-----|-------------|
| T   | Termination |
| +   | TXD+/RXD+   |
| -   | TXD-/RXD-   |
| G   | GND         |

A 4-pin removable terminal block used for:

- Modbus RTU Master connections
- Modbus RTU Slave connections
- ASCII Incoming and Outgoing communications
- Custom Protocol Incoming and Outgoing communications

### RS-485 Port Specifications

| Port Name                            | RS-485   |
|--------------------------------------|--|
| Description                          | Non-isolated RS-485 port connects the CPU as a Modbus/ASCII master or slave to a peripheral device. Includes ESD/EFT protection and automatic echo cancellation when transmitter is active |
| Data Rates                           | Selectable, 1200, 2400, 4800, 9600, 19200, 33600, 38400, 57600, and 115200 baud  |
| TXD+/RXD+                            | RS-485 transceiver high  |
| TXD-/RXD-                            | RS-485 transceiver low   |
| GND                                  | Logic ground   |
| Input Impedance                      | 19 kΩ  |
| Maximum Load                         | 50 transceivers, 19 kΩ each, 60 Ω termination  |
| Output Short Circuit Protection      | ±250 mA, thermal shut-down protection  |
| Electrostatic Discharge Protection   | ±8 kV per IEC1000-4-2  |
| Electrical Fast Transient Protection | ±2 kV per IEC1000-4-4  |
| Minimum Differential Output Voltage  | 1.5 V with 60 Ω load   |
| Fail Safe Inputs                     | Logic high input state if inputs are unconnected   |
| Maximum Common Mode Voltage          | -7.5 V to 12.5 V   |
| Port Status LED                      | Green LED illuminated when active for TXD and RXD  |
| Cable Options                        | L19827-XXX from AutomationDirect.com   |



Removable connector included. Spare connectors available (part no. P3-RS485CON-1).

### Removable Terminal Block Specifications

| Part Number         | P3-RS485CON-1   |
|---------------------|---|
| Number of Positions | 4 screw terminals   |
| Pitch               | 3.5 mm  |
| Wire Range          | 28–16 AWG solid conductor<br>28–16 AWG stranded conductor |
| Screw Driver        | 0.125 inch (3.175 mm) maximum                             |
| Screw Size          | M2  |
| Screw Torque        | 1.7 lb-in (0.4 N·m)                                       |

# Productivity1000 P1-550 CPU Module

## P1-550 Specifications

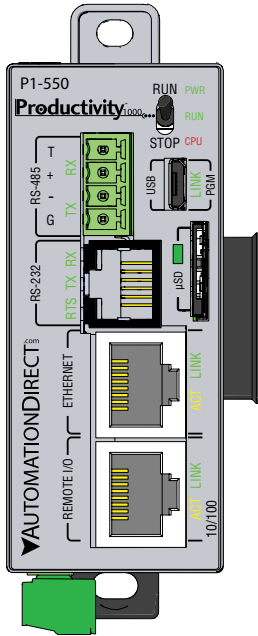

P1-550

| General Specifications    |  |
|---------------------------|--|
| Operating Air Temperature | 0°C– 60°C (32°F–140°F)   |
| Storage Temperature       | -20°C–70°C (-4°F–158°F)  |
| Humidity                  | 5 to 95% (non-condensing)  |
| Environmental Air         | No corrosive gases permitted   |
| Vibration                 | IEC60068-2-6 (Test Fc)   |
| Shock                     | IEC60068-2-27 (Test Ea)  |
| Heat Dissipation          | 3810 mW  |
| Enclosure Type            | Open equipment   |
| Module Location           | Controller connector on the side of the power supply in a Productivity1000 system.                                       |
| Weight                    | 130 g (4.5 oz)   |
| Agency Approvals          | UL 61010-1 and UL 61010-2-201 File E139594, Canada and USA<br>CE (EN 61131-2 EMC, EN 61010-1 and EN 61010-2-201 Safety)* |

\*See CE Declaration of Conformity for details



**NOTE:** The most recent Productivity Suite software and firmware versions may be required to support new modules and new features.



### IMPORTANT!

#### Hot-Swapping Information

**Note:** This device cannot be Hot Swapped.

# Productivity1000 P1-550 CPU Module (continued)

## P1-550 Specifications

| CPU Specifications                    |   |                       |     |                 |                 |                 |                  |                |                  |               |          |                 |       |                |                |
|---------------------------------------|---|-----------------------|-----|-----------------|-----------------|-----------------|------------------|----------------|------------------|---------------|----------|-----------------|-------|----------------|----------------|
| User Memory                           | 50 MB (Includes program, data and documentation)  |                       |     |                 |                 |                 |                  |                |                  |               |          |                 |       |                |                |
| Memory Type                           | Flash and battery-backed RAM  |                       |     |                 |                 |                 |                  |                |                  |               |          |                 |       |                |                |
| Retentive Memory                      | 500 kB  |                       |     |                 |                 |                 |                  |                |                  |               |          |                 |       |                |                |
| Scan Time                             | 1.5 ms (1K Boolean, 240 I/O)  |                       |     |                 |                 |                 |                  |                |                  |               |          |                 |       |                |                |
| External Power Required               | 24 VDC $\pm 2\%$ @ 5W<br>plus 1.25 W per additional I/O module<br>In-Rush current 35 A<br>(see page 2-5 for power supply options)<br>External fuse is required when using external power supply, the recommended fuse is Edison S5062-R, Time Delay, 2 A Fuse (8 I/O Modules)<br>Edison S5061-R Time Delay, 1 A fuse is the recommended fuse for P1-550 hardware rev A or A1 with 8 or fewer I/O modules.   |                       |     |                 |                 |                 |                  |                |                  |               |          |                 |       |                |                |
| Communications;<br>5 Integrated Ports | USB IN: Programming, monitoring, debug, firmware<br>Ethernet: (10/100 Mbps Ethernet) programming, monitoring, debug, firmware, Email SMTP client, Modbus TCP Client (32 Servers) and Server (16 Clients), EtherNet/IP Scanner (32 Adapters) and Adapter (4 Scanners) with 8 connections per device, Custom Protocol over Ethernet, ProNET.<br>Remote I/O: 16 GS drives*, 4 ProtosX TCP couplers, 4 P1-RX remote bases, 1 PS-AMC module<br>RS-232: (RJ12, 1200–115.2 K baud) ASCII, Modbus<br>RS-485: Removable terminal included, (1200–115.2 K baud) ASCII, Modbus RTU |                       |     |                 |                 |                 |                  |                |                  |               |          |                 |       |                |                |
| Data Logging                          | microSD card slot   |                       |     |                 |                 |                 |                  |                |                  |               |          |                 |       |                |                |
| Hardware Limits of System             | 5 Base Groups: 1 Local (P1-550) + 4 Remote (P1-RX)<br>752 Hardware I/O points (all local and remote 16 point I/O)**   |                       |     |                 |                 |                 |                  |                |                  |               |          |                 |       |                |                |
| Instruction Types                     | <table border="0"> <tr> <td>Application functions</td> <td>PID</td> </tr> <tr> <td>Array functions</td> <td>Program Control</td> </tr> <tr> <td>Counters/timers</td> <td>String functions</td> </tr> <tr> <td>Communications</td> <td>System functions</td> </tr> <tr> <td>Data handling</td> <td>Contacts</td> </tr> <tr> <td>Drum Sequencers</td> <td>Coils</td> </tr> <tr> <td>Math functions</td> <td>Motion control</td> </tr> </table>  | Application functions | PID | Array functions | Program Control | Counters/timers | String functions | Communications | System functions | Data handling | Contacts | Drum Sequencers | Coils | Math functions | Motion control |
| Application functions                 | PID   |                       |     |                 |                 |                 |                  |                |                  |               |          |                 |       |                |                |
| Array functions                       | Program Control   |                       |     |                 |                 |                 |                  |                |                  |               |          |                 |       |                |                |
| Counters/timers                       | String functions  |                       |     |                 |                 |                 |                  |                |                  |               |          |                 |       |                |                |
| Communications                        | System functions  |                       |     |                 |                 |                 |                  |                |                  |               |          |                 |       |                |                |
| Data handling                         | Contacts  |                       |     |                 |                 |                 |                  |                |                  |               |          |                 |       |                |                |
| Drum Sequencers                       | Coils   |                       |     |                 |                 |                 |                  |                |                  |               |          |                 |       |                |                |
| Math functions                        | Motion control  |                       |     |                 |                 |                 |                  |                |                  |               |          |                 |       |                |                |
| Real-time Clock Accuracy              | $\pm 2$ s per day typical at 25°C (77°F)<br>$\pm 10$ s per day maximum at 60°C (140°F)  |                       |     |                 |                 |                 |                  |                |                  |               |          |                 |       |                |                |

\*GS Drives require a communications module/card

\*\* If used with 26W or larger power supply.



**NOTE:** If you do not use a Productivity1000 power supply (P1-01AC, P1-02AC or P1-01DC), then use a power supply that has transformer isolation. Use different 24 VDC supplies for the CPU and inductive loads to keep the CPU power clean and free of voltage spikes caused by switching solenoids, motors, or relay coils.

## P1-550 Module Faceplate Layout

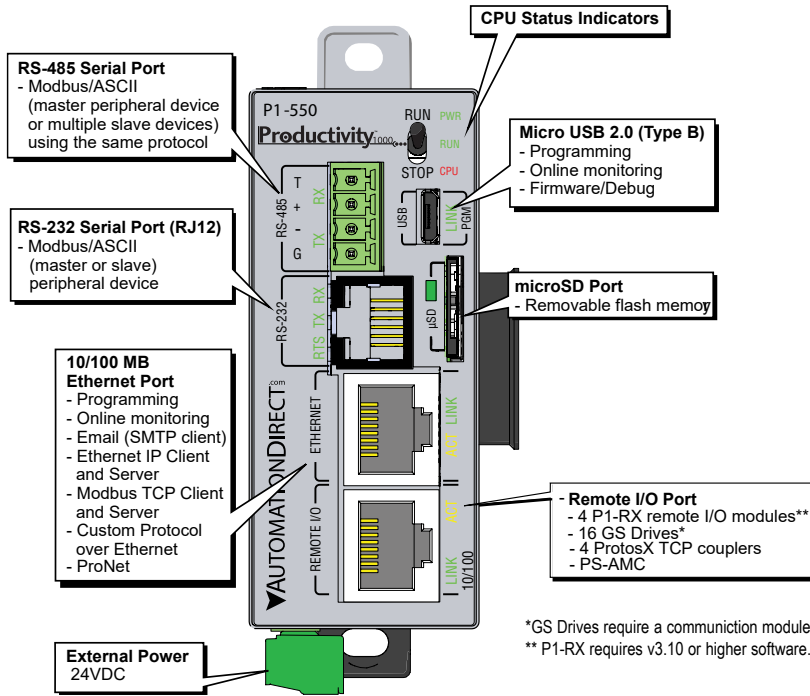

### CPU Run/Stop Switch Specifications

|               |   |
|---------------|---|
| RUN position  | Executes user program, run-time edits possible              |
| STOP position | Does not execute user program, normal program load position |

### CPU Status Indicators

|     |   |
|-----|---|
| PWR | Green LED is illuminated when power is ON                                       |
| RUN | Green LED is illuminated when CPU is in RUN mode                                |
| CPU | Red LED is illuminated during power ON reset, power down, or watch-dog time-out |



## P1-550 Battery

A battery is included with the P1-550 CPU module, but is not installed. The battery may be installed in order to retain the time and date settings along with any tagname values that are set up as retentive.

Please note that the battery is not required for program backup.

### Step One:

Open battery compartment located on the top of the CPU and pull up to locked position.

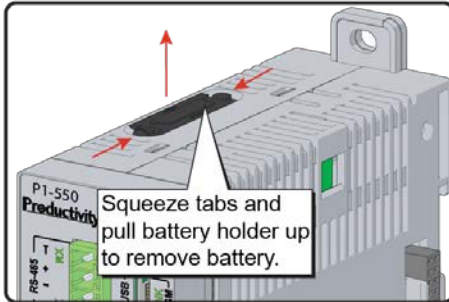

### Step Two:

Insert battery under top two tabs in battery compartment. Press and snap battery behind bottom tab then close the battery compartment.

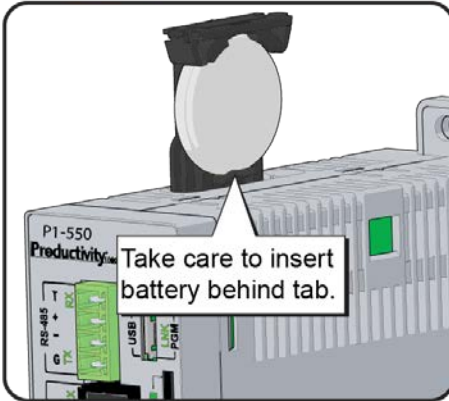
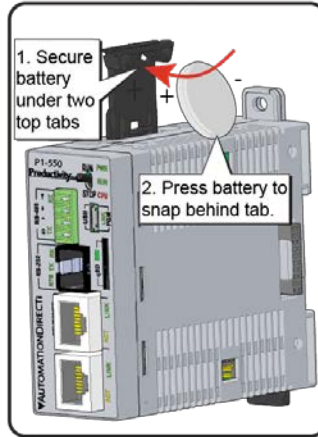

### Battery (Optional)

|          |   |
|----------|---|
| D2-BAT-1 | Coin type, 3.0 V Lithium battery, 560 mA, battery number CR2354 |
|----------|---|

*Note: Although not needed for program backup, an uninstalled battery is included with the P1-550. Install this battery if you want the CPU to retain the Time and Date along with any Tagname values that you have set up as retentive.*

## P1-550 Communication Ports

The P1-550 has several communications ports. The following pages contain the specifications and pin-out diagrams.

### P1-550 microUSB Programming Port

Used exclusively for connecting to a PC running the Productivity Suite programming software.

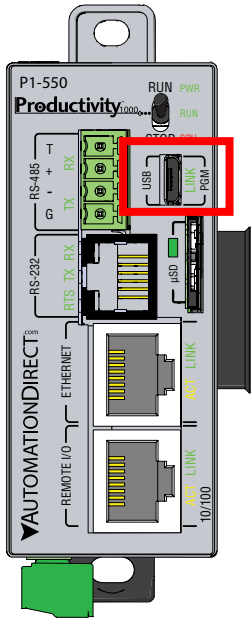

P1-550

### Micro USB Input Specifications

| Port Name       | MicroUSB  |
|-----------------|---|
| Description     | Standard MicroUSB Slave input for programming and on-line monitoring, with built-in surge protection. Not compatible with older full speed USB devices. |
| Transfer Rate   | 480 Mbps  |
| Port Status LED | Green LED is illuminated when LINK is established to programming software.  |
| Cables          | USB Type A to MicroUSB Type B:<br>6 ft cable part # USB-CBL-AMICB6<br>15 ft cable part # USB-CBL-AMICB15  |

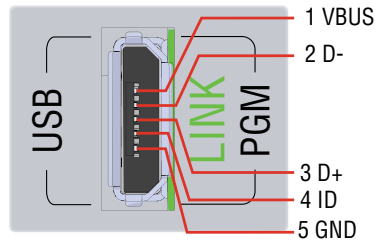

## P1-550 Ethernet Port

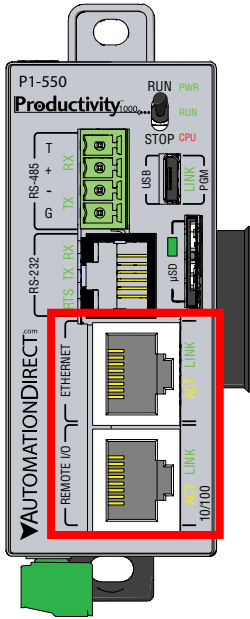

P1-550

### Ethernet Port

- Connection to a PC running the ProductivitySuite programming software
- Modbus TCP Client connections (Modbus requests sent from the CPU)
- Modbus TCP Server connections (Modbus requests received by the CPU)
- EtherNet/IP (Client/Server)
- Custom Protocol over Ethernet (CPOE)
- ProNET
- Outgoing Email

### Remote I/O:

- RJ-45 style connector used for connecting to a Remote I/O network consisting of a P1-RX, GS drives (using Ethernet communication module), ProtosX remote I/O, and/or a PS-AMC module.

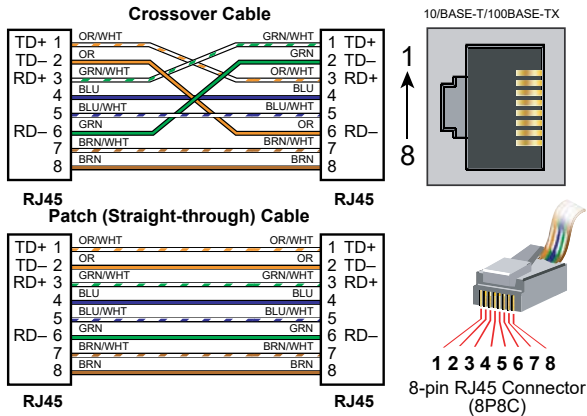

| Ethernet Specifications |  |   |
|-------------------------|--|---|
| Port Name               | Ethernet   | Remote I/O  |
| Description             | Standard transformer-isolated Ethernet port with built-in surge protection for programming, online monitoring, Email (SMTP client), Modbus/TCP client/server connections (fixed IP or DHCP), EtherNet/IP Scanner/Adapter, Custom Protocol over Ethernet and ProNET connections | Standard transformer-isolated Ethernet port with built-in surge protection for connection to 16 GS Series Drives, or 4 P1-RX modules, or 4 ProtosX TCP couplers, and/or one PS-AMC module |
| Transfer Rate           | 10 Mbps (Orange LED) and 100 Mbps (Green LED) (auto-crossover)   |   |
| Port Status LED         | LINK (Amber LED) is solid when network LINK is established. ACT (Green LED) flashes when port is active  |   |

## P1-550 microSD Slot

Used for data logging.

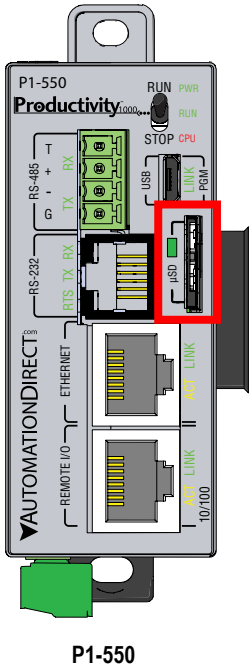

P1-550

### microSD Specifications

|  |   |         |         |         |
|--|---|---------|---------|---------|
| Port Name  | microSD   |         |         |         |
| Description  | Standard microSD socket for data logging                |         |         |         |
| Maximum Card Capacity                                  | 32 GB   |         |         |         |
| Transfer Rate<br>(ADATA microSDHC Class 4 memory card) | Mbps  | Minimum | Typical | Maximum |
|  | Read  | 14.3    | 14.4    | 14.6    |
| Write  | 4.8   | 4.9     | 5.1     |         |
| Port Status LED  | Green LED is illuminated when card is inserted/detected |         |         |         |



| Pin | SD      |
|-----|---------|
| 1   | DAT2    |
| 2   | CD/DAT3 |
| 3   | CMD     |
| 4   | VDD     |
| 5   | CLK     |
| 6   | VSS     |
| 7   | DAT0    |
| 8   | DAT1    |

Note: Card not included with unit.

## P1-550 RS-232 Port

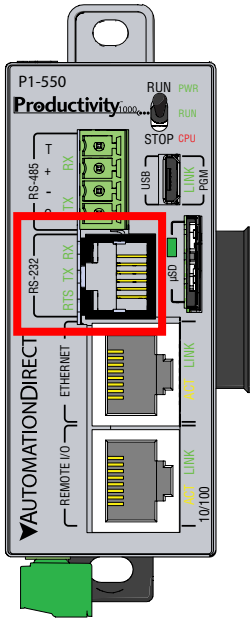

RJ-12 style connector used for:

- Modbus RTU Master connections
- Modbus RTU Slave connections
- ASCII full or half duplex communications
- Custom Protocol Incoming and Outgoing communications

### RS-232 Specifications

| Port Name                       | RS-232   |
|---------------------------------|--|
| Description                     | Non-isolated RS-232 DTE port connects the CPU as a Modbus/ASCII master or slave to a peripheral device. Includes ESD and built-in surge protection |
| Data Rates                      | Selectable, 1200, 2400, 4800, 9600, 19200, 33600, 38400, 57600, and 115200 baud  |
| +5 V Cable Power Source         | 210 mA maximum at 5 V, $\pm 5\%$ . Reverse polarity and overload protected   |
| TXD                             | RS-232 Transmit output   |
| RXD                             | RS-232 Receive input   |
| RTS                             | Handshaking output for modem control   |
| GND                             | Logic ground   |
| Maximum Output Load (TXD/RTS)   | 3 k $\Omega$ , 1000 pf   |
| Minimum Output Voltage Swing    | $\pm 5$ V  |
| Output Short Circuit Protection | $\pm 15$ mA  |
| Port Status LED                 | Green LED is illuminated when active for TXD, RXD and RTS  |
| Cable Options                   | EA-MG-PGM-CBL<br>D2-DSCBL<br>USB-RS232-1 with D2-DSCBL<br>FA-CABKIT<br>FA-ISOCOON for converting RS-232 to isolated RS-485                         |

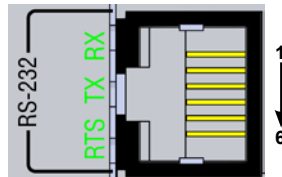

6-Pin RJ12 Female Modular Connector

| Pin | Label | Signal         |
|-----|-------|----------------|
| 1   | GND   | Logic Ground   |
| 2   | +5 V  | 210 mA Maximum |
| 3   | RXD   | RS-232 Input   |
| 4   | TXD   | RS-232 Output  |
| 5   | RTS   | RS-232 Output  |
| 6   | GND   | Logic Ground   |



# Productivity<sup>®</sup>1000 P1-622 CPU Module

## P1-622 Specifications

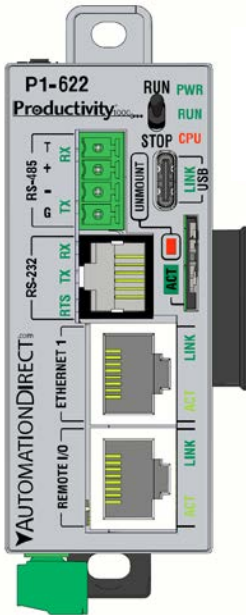

P1-622



**IMPORTANT!**

### Hot-Swapping Information

**Note:** This device cannot be Hot Swapped.

### CPU Specifications

|                                       |  |                       |     |                 |                 |                 |                  |                |                  |               |          |                 |       |                |                 |
|---------------------------------------|--|-----------------------|-----|-----------------|-----------------|-----------------|------------------|----------------|------------------|---------------|----------|-----------------|-------|----------------|-----------------|
| User Memory                           | 50 MB (Includes program, data and documentation)   |                       |     |                 |                 |                 |                  |                |                  |               |          |                 |       |                |                 |
| Memory Type                           | Flash and battery-backed RAM   |                       |     |                 |                 |                 |                  |                |                  |               |          |                 |       |                |                 |
| Retentive Memory                      | 512 KB   |                       |     |                 |                 |                 |                  |                |                  |               |          |                 |       |                |                 |
| Scan Time                             | 1.9 ms (1K Boolean, 240 I/O)   |                       |     |                 |                 |                 |                  |                |                  |               |          |                 |       |                |                 |
| External Power Required               | 24 VDC $\pm$ 2% @ 5 W<br>plus 1.25 W per additional I/O module   |                       |     |                 |                 |                 |                  |                |                  |               |          |                 |       |                |                 |
| Protection Circuit                    | Edison S5062-R, Time Delay, 2 A Fuse (15 I/O Modules)  |                       |     |                 |                 |                 |                  |                |                  |               |          |                 |       |                |                 |
| Communications;<br>5 Integrated Ports | <b>USB:</b> Programming, monitoring, debug, firmware<br><b>Ethernet:</b> (10/100 Mbps Ethernet) programming, monitoring, debug, firmware, email SMTP client, MQTT, Modbus TCP Client (8 Servers) and server (4 Clients), EtherNet/IP scanner (4) and adapter (2), custom protocol over Ethernet, ProNET.<br><b>Remote I/O:</b> 16 GS Drives*, 4 ProtosX TCP couplers, 4 P1-RX remote bases, 1 PS-AMC module<br><b>RS-232:</b> (RJ12, 1200–115.2 K baud) ASCII, Modbus<br><b>RS-485:</b> Removable terminal included, (1200–115.2 K baud) ASCII, Modbus RTU |                       |     |                 |                 |                 |                  |                |                  |               |          |                 |       |                |                 |
| Data Logging                          | microSD card slot  |                       |     |                 |                 |                 |                  |                |                  |               |          |                 |       |                |                 |
| Hardware Limits of System             | <b>5 Base Groups:</b> 1 local (P1-622) + 4 Remote (P1-RX)<br><b>752 Hardware I/O Points:</b> (All local and remote 16-point I/O modules)   |                       |     |                 |                 |                 |                  |                |                  |               |          |                 |       |                |                 |
| Instruction Types                     | <table border="0"> <tr> <td>Application functions</td> <td>PID</td> </tr> <tr> <td>Array functions</td> <td>Program control</td> </tr> <tr> <td>Counters/timers</td> <td>String functions</td> </tr> <tr> <td>Communications</td> <td>System functions</td> </tr> <tr> <td>Data handling</td> <td>Contacts</td> </tr> <tr> <td>Drum sequencers</td> <td>Coils</td> </tr> <tr> <td>Math Functions</td> <td>Monitor Control</td> </tr> </table>  | Application functions | PID | Array functions | Program control | Counters/timers | String functions | Communications | System functions | Data handling | Contacts | Drum sequencers | Coils | Math Functions | Monitor Control |
| Application functions                 | PID  |                       |     |                 |                 |                 |                  |                |                  |               |          |                 |       |                |                 |
| Array functions                       | Program control  |                       |     |                 |                 |                 |                  |                |                  |               |          |                 |       |                |                 |
| Counters/timers                       | String functions   |                       |     |                 |                 |                 |                  |                |                  |               |          |                 |       |                |                 |
| Communications                        | System functions   |                       |     |                 |                 |                 |                  |                |                  |               |          |                 |       |                |                 |
| Data handling                         | Contacts   |                       |     |                 |                 |                 |                  |                |                  |               |          |                 |       |                |                 |
| Drum sequencers                       | Coils  |                       |     |                 |                 |                 |                  |                |                  |               |          |                 |       |                |                 |
| Math Functions                        | Monitor Control  |                       |     |                 |                 |                 |                  |                |                  |               |          |                 |       |                |                 |
| Real-time Clock Accuracy              | $\pm$ 2 s per day at typical 25°C<br>$\pm$ 10 s per day maximum at 60°C  |                       |     |                 |                 |                 |                  |                |                  |               |          |                 |       |                |                 |

\*GS drive requires communication module/ card



**NOTE:** The most recent Productivity Suite software and firmware versions may be required to support new modules and new features.

# Productivity® 1000 P1-622 CPU Module (continued)

## P1-622 General Specifications

| General Specifications  |  |
|---|--|
| Operating Air Temperature   | 0°C to 60°C (32°F to 140°F)  |
| Storage Temperature   | -20°C to 70°C (-4°F to 158°F)  |
| Humidity  | 5 to 95% (non-condensing)  |
| Altitude  | 2000 meters max.   |
| Pollution Degree  | 2  |
| Environmental Air   | No corrosive gases permitted   |
| Vibration   | IEC60068-2-6 (Test Fc)   |
| Shock   | IEC60068-2-27 (Test Ea)  |
| Overvoltage Category  | II   |
| Heat Dissipation  | 3592 mW  |
| Enclosure Type  | Open equipment   |
| Module Location   | Controller connector on the side of the power supply in a Productivity1000 system.                                       |
| Weight  | 127 g (4.3 oz)   |
| Agency Approvals<br>(See CE Declaration of Conformity for details.) | UL 61010-1 and UL 61010-2-201 File E139594, Canada and USA<br>CE (EN 61131-2 EMC, EN 61010-1 and EN 61010-2-201 Safety)* |

\*See CE Declaration of Conformance for Details.

## P1-622 Module Faceplate Layout

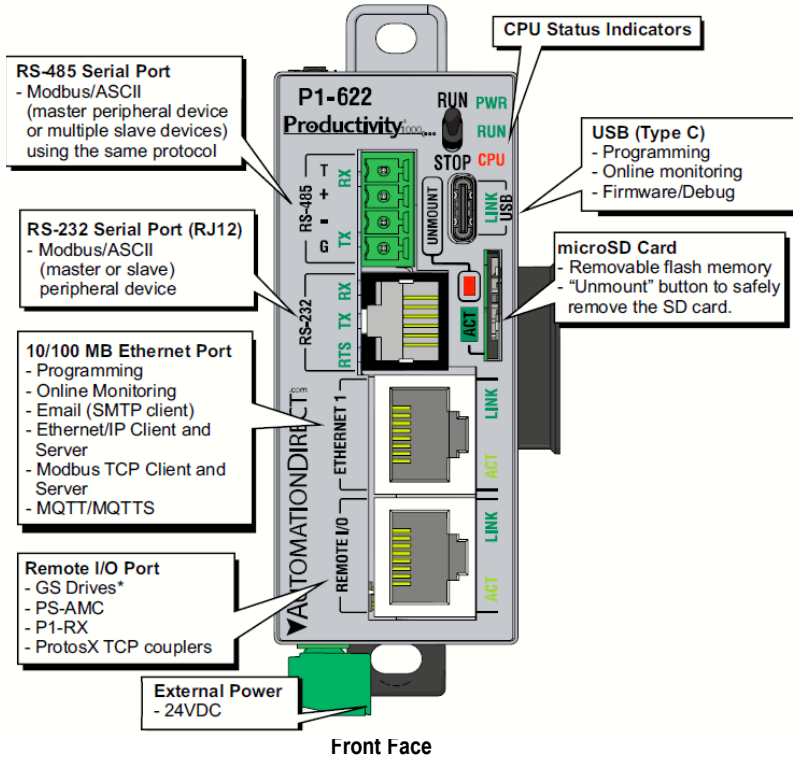

### CPU Run/Stop Switch Specifications

|               |   |
|---------------|---|
| RUN position  | Executes user program, run-time edits possible              |
| STOP position | Does not execute user program, normal program load position |

### CPU Status Indicators

|     |   |
|-----|---|
| PWR | Green LED is illuminated when power is ON                                       |
| RUN | Green LED is illuminated when CPU is in RUN mode                                |
| CPU | Red LED is illuminated during power ON reset, power down, or watch-dog time-out |



## P1-622 External Power Terminal

Located on the bottom of the CPU, it is used for connecting to an alternate external power supply. Productivity1000 series has multiple power supplies to choose from.

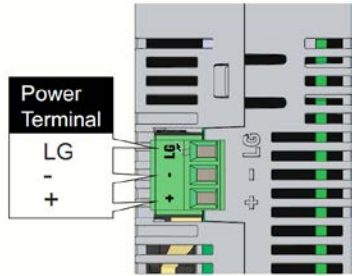

**P1-622**  
Bottom Face

### Removable Terminal Block Specifications

|                     |   |
|---------------------|---|
| Part Number         | PCON-KIT  |
| Number of Positions | 3 Screw Terminals   |
| Pitch               | 3.5 mm  |
| Wire Range          | 28-16 AWG Solid conductor<br>28-16 AWG Stranded conductor |
| Screw Driver Width  | 1/8 in. (3.175 mm) Maximum                                |
| Screw Size          | M2  |
| Screw Torque        | 1.7 lb-in (0.4 N-m)                                       |



**NOTE:** If you do not use one of the Productivity1000 power supplies (P1-01AC, P1-02AC or P1-01DC), then use a power supply that has transformer isolation. Use different 24VDC supplies for the CPU and inductive loads to keep the CPU power clean and free of voltage spikes caused by switching solenoids, motors, or relay coils.

### P1-622 Communication Ports

The P1-622 has several communications ports. The following pages contain the specifications and pin-out diagrams.

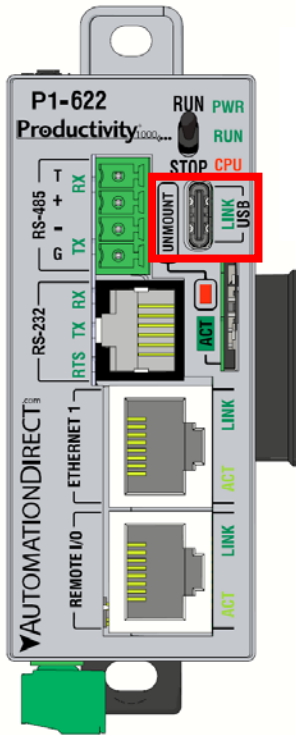

### P1-622 USB-C Programming Port

Used exclusively for connecting to a PC running the Productivity Suite programming software.

#### USB-C Slave Input Specifications

|                 |  |
|-----------------|--|
| Port Name       | USB-C  |
| Description     | Standard USB-C Slave input for programming and on-line monitoring, with built-in surge protection. Not compatible with older full speed USB devices. |
| Transfer Rate   | 480 Mbps   |
| Port Status LED | Green LED is illuminated when LINK is established to programming software.   |
| Cables          | USB Type A to MicroUSB Type C:<br>6 ft cable part # USB-CBL-AC6  |

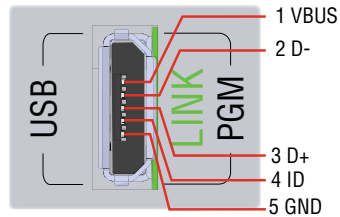

## P1-622 Ethernet Port

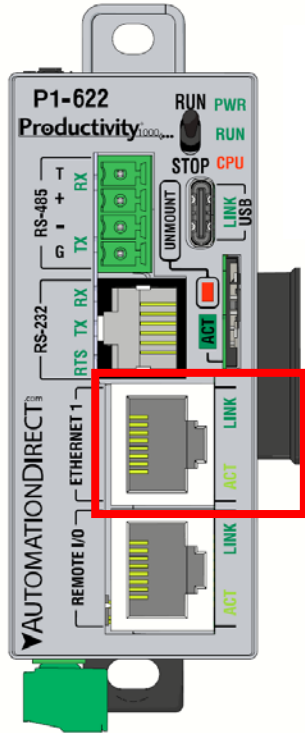

P1-622

### Ethernet Port

- Connection to a PC running the ProductivitySuite programming software
- Modbus TCP Client connections (32 Servers) (Modbus requests sent from the CPU)
- Modbus TCP Server connections (16 Clients) (Modbus requests received by the CPU)
- EtherNet/IP Scanner (32 Adapters) and Adapter (4 Scanners) with 8 connections per device.
- Custom Protocol over Ethernet (CPoE)
- ProNET
- MQTT/MQTTS
- Outgoing Email

### Remote I/O:

- RJ-45 style connector used for connecting to a Remote I/O network consisting of a 4 P1-RX remote bases, 16 GS drives (using Ethernet communication module), 4 ProtosX TCP couplers, and/or 1 PS-AMC module.

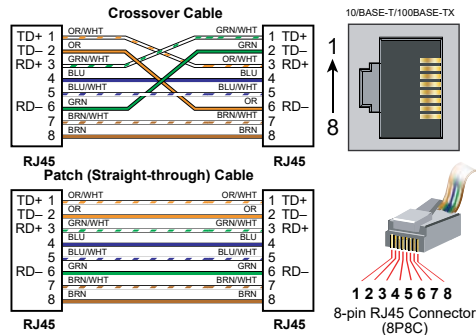

| Ethernet Specifications |   |  |
|-------------------------|---|--|
| Port Name               | Ethernet  | Remote I/O   |
| Description             | Standard transformer-isolated Ethernet port with built-in surge protection for programming, online monitoring, Email (SMTP client), Modbus/TCP client/server connections (fixed IP or DHCP), EtherNet/IP Scanner/Adapter, Custom Protocol over Ethernet and ProNET, MQTT/MQTTS. | Standard transformer-isolated Ethernet port with built-in surge protection for connection to supported remote I/O devices. |
| Transfer Rate           | 10 Mbps and 100 Mbps (auto-crossover)   |  |
| Port Status LED         | LINK (Amber LED) is solid when network LINK is established. ACT (Green LED) flashes when port is active   |  |

### P1-622 microSD Slot

Used for data logging.

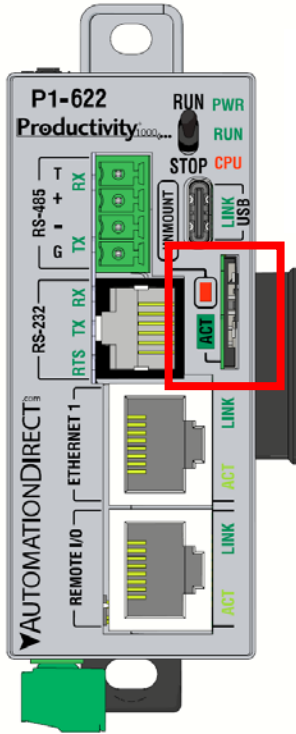

P1-622

| microSD Specifications                                    |   |         |         |         |
|---|---|---------|---------|---------|
| Port Name   | microSD   |         |         |         |
| Description   | Standard microSD socket for data logging                |         |         |         |
| Maximum Card Capacity                                     | 32 GB   |         |         |         |
| Transfer Rate<br>(ADATA microSDHC<br>Class 4 memory card) | Mbps  | Minimum | Typical | Maximum |
|   | Read  | 14.3    | 14.4    | 14.6    |
|   | Write   | 4.8     | 4.9     | 5.1     |
| Port Status LED   | Green LED is illuminated when card is inserted/detected |         |         |         |



Note: Card not included with unit.

| Pin | SD      |
|-----|---------|
| 1   | DAT2    |
| 2   | CD/DAT3 |
| 3   | CMD     |
| 4   | VDD     |
| 5   | CLK     |
| 6   | VSS     |
| 7   | DAT0    |
| 8   | DAT1    |

## P1-622 RS-232 Port

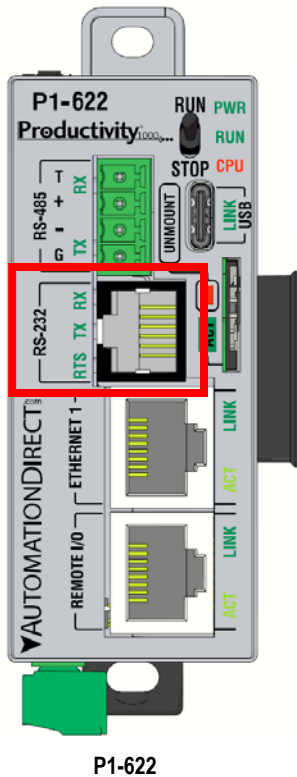

RJ-12 style connector used for:

- Modbus RTU Master connections
- Modbus RTU Slave connections
- ASCII full or half duplex communications
- Custom Protocol Incoming and Outgoing communications

### RS-232 Specifications

|                                 |  |
|---------------------------------|--|
| Port Name                       | RS-232   |
| Description                     | Non-isolated RS-232 DTE port connects the CPU as a Modbus/ASCII master or slave to a peripheral device. Includes ESD and built-in surge protection |
| Data Rates                      | Selectable, 1200, 2400, 4800, 9600, 19200, 33600, 38400, 57600, and 115200 baud  |
| +5V Cable Power Source          | 210 mA maximum at 5 V, $\pm 5\%$ . Reverse polarity and overload protected   |
| TXD                             | RS-232 Transmit output   |
| RXD                             | RS-232 Receive input   |
| RTS                             | Handshaking output for modem control   |
| GND                             | Logic ground   |
| Maximum Output Load (TXD/RTS)   | 3 k $\Omega$ , 1000 pf   |
| Minimum Output Voltage Swing    | $\pm 5$ V  |
| Output Short Circuit Protection | $\pm 15$ mA  |
| Port Status LED                 | Green LED is illuminated when active for TXD, RXD and RTS  |
| Cable Options                   | EA-MG-PGM-CBL<br>D2-DSCBL<br>USB-RS232 with D2-DSCBL<br>FA-CABKIT<br>FA-ISOCAN for converting RS-232 to isolated RS-485                            |

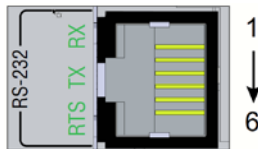

6-Pin RJ12 Female Modular Connector

| Pin | Label | Signal        |
|-----|-------|---------------|
| 1   | GND   | Logic Ground  |
| 2   | +5V   | 210mA Maximum |
| 3   | RXD   | RS-232 Input  |
| 4   | TXD   | RS-232 Output |
| 5   | RTS   | RS-232 Output |
| 6   | GND   | Logic Ground  |

## P1-622 RS-485 Port

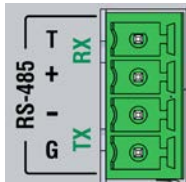
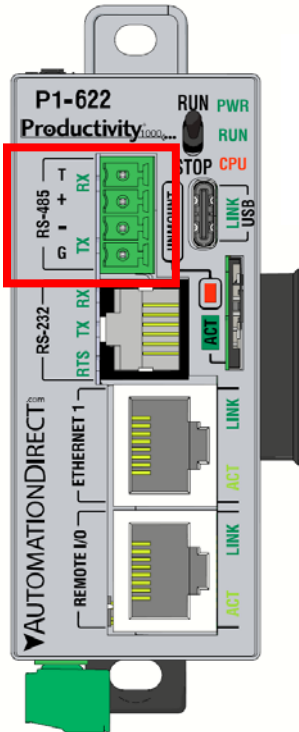

| Pin | Signal      |
|-----|-------------|
| T   | Termination |
| +   | TXD+/RXD+   |
| -   | TXD-/RXD-   |
| G   | GND         |



Removable connector included. Spare connectors available (part no. P3-RS485CON-1).

A 4-pin removable terminal block used for:

- Modbus RTU Master connections
- Modbus RTU Slave connections
- ASCII Incoming and Outgoing communications
- Custom Protocol Incoming and Outgoing communications

### RS-485 Port Specifications

| Port Name  | RS-485   |
|--|--|
| Description  | Non-isolated RS-485 port connects the CPU as a Modbus/ASCII master or slave to a peripheral device. Includes ESD/EFT protection and automatic echo cancellation when transmitter is active |
| Data Rates   | Selectable, 1200, 2400, 4800, 9600, 19200, 33600, 38400, 57600, and 115200 baud  |
| TXD+/RXD+  | RS-485 transceiver high  |
| TXD-/RXD-  | RS-485 transceiver low   |
| GND  | Logic ground   |
| Input Impedance                                    | 19 k $\Omega$  |
| Termination Resistance (TB jumper wire "T" to "+") | 120 $\Omega$ To use, add a jumper between "T" and "+". Resistor is internally connected between "T" and "-".   |
| Maximum Load                                       | 50 transceivers, 19 k $\Omega$ each, 60 $\Omega$ termination   |
| Output Short Circuit Protection                    | $\pm$ 250 mA, thermal shut-down protection   |
| Electrostatic Discharge Protection                 | Contact $\pm$ 4kV, Air $\pm$ 8kV per IEC1000-4-2<br>Cable is installed for testing   |
| Electrical Fast Transient Protection               | $\pm$ 1kV per IEC1000-4-4  |
| Minimum Differential Output Voltage                | 1.5 V with 60 $\Omega$ load  |
| Fail Safe Inputs                                   | Logic high input state if inputs are unconnected   |
| Maximum Common Mode Voltage                        | -7.5 V to 12.5 V   |
| Port Status LED                                    | Green LED illuminated when active for TXD and RXD  |
| Cable Options                                      | Go to AutomationDirect.com for RS-232 and RS-285 cables.   |

### Removable Terminal Block Specifications

|                     |   |
|---------------------|---|
| Part Number         | P3-RS485CON-1   |
| Number of Positions | 4 screw terminals   |
| Pitch               | 3.5 mm  |
| Wire Range          | 28–16 AWG solid conductor<br>28–16 AWG stranded conductor |
| Screw Driver        | 0.125 inch (3.175 mm) maximum                             |
| Screw Size          | M2  |
| Screw Torque        | 1.7 lb-in (0.4 N·m)                                       |

# Productivity<sup>®</sup> 1000 Mini PLC Overview

A variety of discrete and analog I/O modules configurations are available within the P1000 Mini system. Any of the P1000 system I/O modules can be used to extend I/O capability of the P1000 Mini PLCs.

Each PLC module is identified on the face using the color-coding scheme shown below. The pages following provide P1000 Mini PLC module specifications.

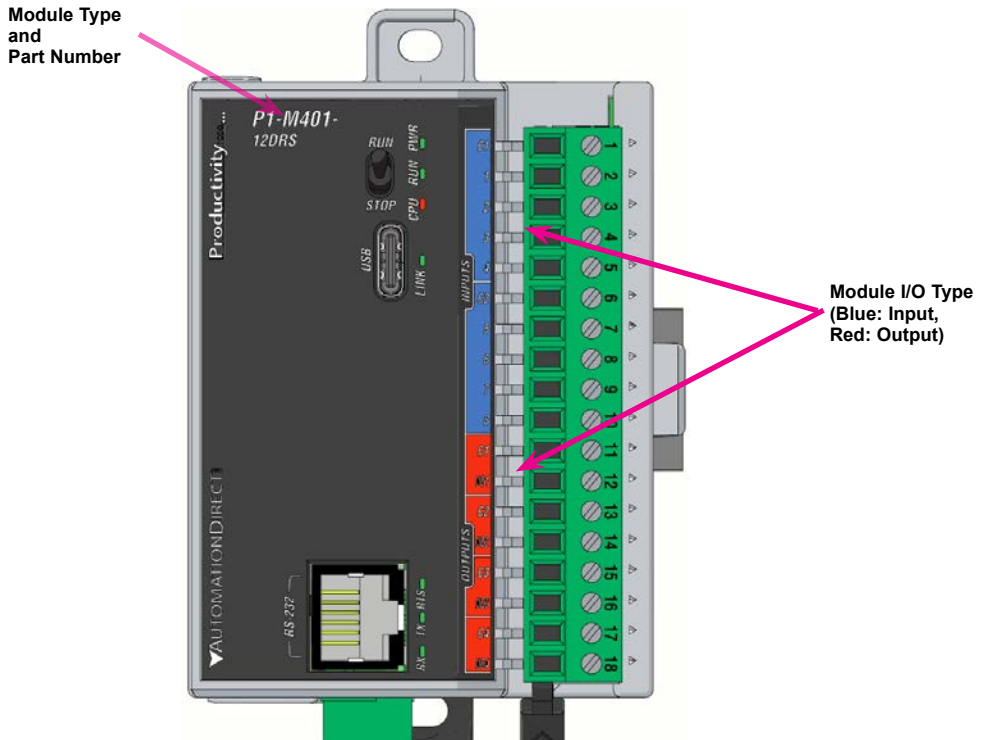

### P1-M401 PLC Modules

Each P1-M401 PLC can be used as a stand-alone controller for small applications or expanded by connecting two additional P1000 I/O modules.

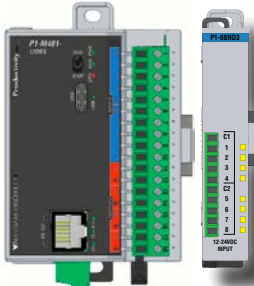

| P1-M401 PLC Modules |                           |                    |
|---------------------|---------------------------|--------------------|
| Part Number         | Number of Inputs          | Number of Outputs  |
| P1-M401-15DD2       | 8 sinking/sourcing inputs | 7 sourcing outputs |
| P1-M401-12DRS       | 8 sinking/sourcing inputs | 4 relay outputs    |
| P1-M401-16DR        | 8 sinking/sourcing inputs | 8 relay outputs    |

### P1-M412 PLC Modules

Each P1-M412 PLC can be used as a stand-alone controller for small applications or expanded with two additional P1000 I/O modules.

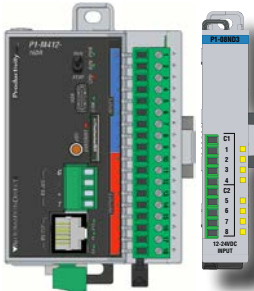

| P1-M412 PLC Modules          |                                     |                                    |
|------------------------------|-------------------------------------|------------------------------------|
| Part Number                  | Number of Inputs                    | Number of Outputs                  |
| <b>Discrete I/O Versions</b> |                                     |                                    |
| P1-M412-15DD2                | 8 sinking/sourcing inputs           | 7 sourcing outputs                 |
| P1-M412-12DRS                | 8 sinking/sourcing inputs           | 4 relay outputs                    |
| P1-M412-16DR                 | 8 sinking/sourcing inputs           | 8 relay outputs                    |
| P1-M412-16ND3                | 16 sinking/sourcing inputs          | N/A                                |
| <b>Analog I/O Versions</b>   |                                     |                                    |
| P1-M412-08ADL-1              | 8 current sinking 0-20 mA           | N/A                                |
| P1-M412-04THM                | 4 differential, 16-bit thermocouple | N/A                                |
| P1-M412-4ADL2DAL-1           | 4 current sinking 0-20 mA; 13-bit   | 2 current sourcing 4-20 mA; 12-bit |

### P1-M622 PLC Modules

Each P1-M622 PLC can be used as a stand-alone controller for small applications or expanded with four additional P1000 I/O modules.

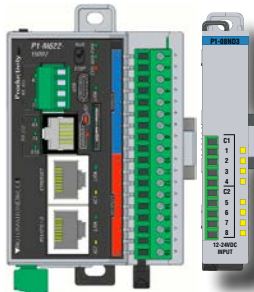

| P1-M622 PLC Modules          |                                     |                                    |
|------------------------------|-------------------------------------|------------------------------------|
| Part Number                  | Number of Inputs                    | Number of Outputs                  |
| <b>Discrete I/O Versions</b> |                                     |                                    |
| P1-M622-15DD2                | 8 sinking/sourcing inputs           | 7 sourcing outputs                 |
| P1-M622-12DRS                | 8 sinking/sourcing inputs           | 4 relay outputs                    |
| P1-M622-16DR                 | 8 sinking/sourcing inputs           | 8 relay outputs                    |
| P1-M622-16ND3                | 16 sinking/sourcing inputs          | N/A                                |
| <b>Analog I/O Versions</b>   |                                     |                                    |
| P1-M622-08ADL-1              | 8 current sinking 0-20 mA (13-bit)  | N/A                                |
| P1-M622-04THM                | 4 differential, 16-bit thermocouple | N/A                                |
| P1-M622-4ADL2DAL-1           | 4 current sinking 0-20 mA (13-bit)  | 2 current sourcing 4-20 mA; 12-bit |

P1 Mini PLC Features

| P1 Mini PLC Series Features Comparison |  |  |  |
|--|--|--|--|
|  | P1-M401-xxx  | P1-M412-xxx  | P1-M622-xxx  |
| User Memory                            | 32 MB (includes program, data and documentation)   |  | 50 MB (includes program, data and documentation)   |
| Memory Type                            | Flash and RAM  |  | Flash and battery-backed RAM   |
| Retentive Memory                       | 27KB   |  | 512 KB   |
| Scan Time                              | 1.7 ms (1 K Boolean, Max I/O)  |  | 1.9 ms (1 K Boolean, max I/O)  |
| External Power Required                | 24 VDC ±2% @ 6W plus 1.25 W per additional I/O module. Protection circuit not built into module; install protection element such as Edison S5061-R, time delay, 1 A fuse |  |  |
| Communication                          | 2 Integrated Ports   | 4 integrated ports   | 5 integrated ports   |
|  | USB IN: Programming, Monitoring, Debug, Firmware   |  |  |
|  | N/A  | ETHERNET: (10/100Mbps Ethernet) Programming, Monitoring, Debug, Firmware, Email SMTP Client, Modbus TCP Client (8 Servers) and Server (4 Clients), Ethernet IP Scanner (4 adapters) and Adapter (2 scanners), Custom protocol over Ethernet, ProNet, MQTT/MQTTS. | ETHERNET: (10/100Mbps Ethernet) Programming, Monitoring, Debug, Firmware, Email SMTP Client, Modbus TCP Client (32Servers) and Server (16 Clients), Ethernet IP Scanner (32 Adapters) and Adapter (4 scanners) with 8 connections per device. Custom protocol over Ethernet, ProNet, MQTT/MQTTS. |
|  | N/A  | N/A  | REMOTE I/O: 16 GS Drives, 4 ProtosX TCP couplers, 4 P1-RX remote bases, 1 PS-AMC* module   |
|  | RS-232: (RJ-12, 1200-115.2 K baud) ASCII, Modbus   |  |  |
|  | N/A  | RS-485: Removable terminal included, (1200-115.2 K baud) ASCII, Modbus RTU   | RS-485: Removable terminal included, (1200-115.2 K baud) ASCII, Modbus RTU   |
| Data Logging                           | N/A  | MicroSD card slot  | MicroSD card slot  |
| Hardware Limits of System              | Onboard I/O + 2 additional modules (up to 16 points each)  | Onboard I/O + 2 additional modules (up to 16 points each)  | Onboard I/O + 4 additional modules (up to 16 points each)  |
| Instruction Types                      | Application Functions, Array Functions, Counters/Timers Communications   | Data handling<br>Drum sequencers<br>Math functions<br>PID<br>Program control   | String functions<br>System functions<br>Contacts<br>Coils<br>*Motion Control   |
| Real Time Clock                        | None   | None   | Accuracy:<br>±2 s per day at typical 25°C<br>±10 s per day maximum at 60°C   |

\* Motion Control only available in the P1-M622xxx series PLC

## Power Terminal

Power to the module for connecting to an alternative external power supply.

| Removable Terminal Block Specifications |   |
|---|---|
| Part Number                             | PCON-KIT  |
| Number of Positions                     | 3 screw terminals   |
| Pitch                                   | 3.5 mm  |
| Wire Range                              | 28-16 AWG solid conductor<br>28-16 AWG stranded conductor |
| Screwdriver Width                       | 1/8 in. (3.175 mm) max.                                   |
| Screw Size                              | M2  |
| Screw Torque                            | 1.7 lb-in (0.4 N-m)                                       |

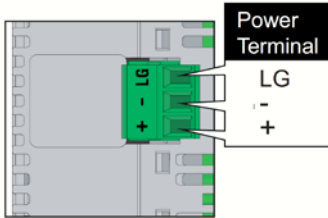

Bottom View

## Run/Stop Switch



### CPU Status Indicators

|     |   |
|-----|---|
| PWR | Green LED is illuminated when power is ON                                       |
| RUN | Green LED is illuminated when CPU is in RUN mode                                |
| CPU | Red LED is illuminated during power ON reset, power down, or watch-dog time-out |

### CPU Run/Stop Switch Specifications

|               |   |
|---------------|---|
| RUN Position  | Executes user program, run-time edits possible              |
| STOP Position | Does not execute user program, normal program load position |

## Communication Ports

The P1 Mini PLC has several communications ports. The following pages contain the specifications for each of the communication ports.

### USB Programming Port

Used exclusively for connecting to a PC running the Productivity Suite programming software.



#### USB-C Slave Input Specifications

| Port Name       | USB-C  |
|-----------------|--|
| Description     | Standard USB-C Slave input for programming and on-line monitoring, with built-in surge protection. Not compatible with older full-speed USB devices. |
| Transfer Rate   | 480 Mbps   |
| Port Status LED | Green LED is illuminated when LINK is established to programming software.   |
| Cables          | USB Type A to MicroUSB Type C:<br>6 ft cable part # USB-CBL-AC6  |

### microSD Slot

P1-M412 series and P1-M622 series have a microSDslot that is used for data logging.



#### microSD Specifications

| Port Name                              | microSD   |         |         |         |
|--|---|---------|---------|---------|
| Description                            | Standard microSD socket for data logging                    |         |         |         |
| Maximum Card Capacity                  | 32 GB SDHC  |         |         |         |
| Transfer Rate<br>(Class 4 memory card) | Mbps  | Minimum | Typical | Maximum |
|  | Read  | 14.3    | 14.4    | 14.6    |
|  | Write   | 4.8     | 4.9     | 5.1     |
| Port Status LED                        | Green LED is illuminated when card is inserted/<br>detected |         |         |         |

\*Supported microSD MICSD-16G



Note: Card not included with unit.

| Pin | SD      |
|-----|---------|
| 1   | DAT2    |
| 2   | CD/DAT3 |
| 3   | CMD     |
| 4   | VDD     |
| 5   | CLK     |
| 6   | VSS     |
| 7   | DAT0    |
| 8   | DAT1    |

### Communication Ports, cont'd

#### RS-232 Port

RJ-12 style connector used for the following:

- Modbus RTU Master connections
- Modbus RTU Slave connections
- ASCII full- or half-duplex communications
- Custom protocol incoming and outgoing communications

| RS-232 Specifications           |   |
|---------------------------------|---|
| Port Name                       | RS-232  |
| Description                     | Non-isolated RS-232 DTE port connects the CPU as a Modbus/ASCII master or slave to a peripheral device. Includes ESD and built-in surge protection. |
| Data Rates                      | Selectable, 1200, 2400, 4800, 9600, 19200, 33600, 38400, 57600, and 115200 baud   |
| +5V Cable Power Source          | 210 mA maximum at 5 V, $\pm 5\%$ . Reverse polarity and overload protected.   |
| TXD                             | RS-232 Transmit output  |
| RXD                             | RS-232 Receive input  |
| RTS                             | Handshaking output for modem control.   |
| GND                             | Logic ground  |
| Maximum Output Load (TXD/RTS)   | 3 k $\Omega$ , 1000 pf  |
| Minimum Output Voltage Swing    | $\pm 5$ V   |
| Output Short Circuit Protection | $\pm 15$ mA   |
| Port Status LED                 | Green LED is illuminated when active for TXD, RXD and RTS.  |
| Cable Options                   | EA-MG-PGM-CBL<br>D2-DSCBL<br>USB-RS232-1 with D2-DSCBL<br>FA-CABKIT<br>FA-ISOCON for converting RS-232 to isolated RS-485                           |

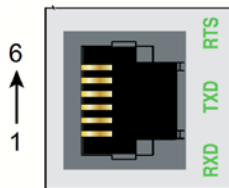

6-Pin RJ12 Female  
Modular Connector

| Pin | Label | Signal        |
|-----|-------|---------------|
| 6   | GND   | Logic Ground  |
| 5   | RTS   | RS-232 Output |
| 4   | TXD   | RS-232 Output |
| 3   | RXD   | RS-232 Input  |
| 2   | +5V   | 210mA Maximum |
| 1   | GND   | Logic Ground  |

## Communication Ports, Cont'd

### RS-485 Port

A 4-pin removable terminal block used for the following:

- Modbus RTU Master connections
- Modbus RTU Slave connections
- ASCII incoming and outgoing communications
- Custom protocol incoming and outgoing communications

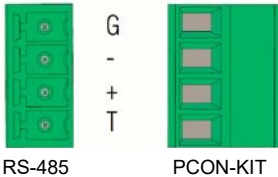

| Pin | Signal      |
|-----|-------------|
| G   | GND         |
| -   | TXD-/RXD-   |
| +   | TXD+/RXD+   |
| T   | Termination |

Removable connector included. Spare connectors available (part no. PCON-KIT).

| RS-485 Port Specifications                         |  |
|--|--|
| Port Name  | RS-485   |
| Description  | Non-isolated RS-485 port connects the CPU as a Modbus/ASCII master or slave to a peripheral device. Includes ESD/EFT protection and automatic echo cancellation when transmitter is active |
| Data Rates   | Selectable, 1200, 2400, 4800, 9600, 19200, 33600, 38400, 57600, and 115200 baud  |
| TXD+/RXD+  | RS-485 transceiver high  |
| TXD-/RXD-  | RS-485 transceiver low   |
| GND  | Logic ground   |
| Input Impedance                                    | 19 kΩ  |
| Termination Resistance (TB jumper wire "T" to "+") | 120 Ω; Add a jumper between "T" and "+". Resistor is <i>internally</i> connected between "T" and "-".  |
| Maximum Load                                       | 50 transceivers, 19kΩ each, 60Ω termination  |
| Output Short Circuit Protection                    | ±250 mA, thermal shut-down protection  |
| Electrostatic Discharge Protection                 | Contact ±4 kV, Air ±8 kV per IEC1000-4-2<br>Cable is installed for testing   |
| Electrical Fast Transient Protection               | ±1 kV per IEC1000-4-4  |
| Minimum Differential Output Voltage                | 1.5 V with 60Ω load  |
| Fail Safe Inputs                                   | Logic high input state if inputs are unconnected   |
| Maximum Common Mode Voltage                        | -7.5 V to 12.5 V   |
| Port Status LED                                    | Green LED illuminated when active for TXD and RXD  |
| Cable Options                                      | Go to <a href="http://AutomationDirect.com">AutomationDirect.com</a> for RS-232 and RS-285 cables.   |

| Removable Terminal Block Specifications |   |
|---|---|
| Part Number                             | P3-RS485CON-1   |
| Number of Positions                     | 4 screw terminals   |
| Pitch                                   | 3.5 mm  |
| Wire Range                              | 28–16 AWG solid conductor<br>28–16 AWG stranded conductor |
| Screw Driver                            | 0.125 in. (3.175 mm) maximum                              |
| Screw Size                              | M2  |
| Screw Torque                            | 1.7 lb-in (0.4 N-m)                                       |

### P1-M412 Ethernet Port

RJ-45 style connector used for the following:

- Connection to a PC running the Productivity Suite programming software
- Modbus TCP Client connections (Modbus requests sent from the CPU)
- Modbus TCP Server connections (Modbus requests received by the CPU)
- EtherNet/IP (Client/Server)
- Custom Protocol over Ethernet
- ProNET
- MQTT/MQTTS
- Outgoing Email

| Ethernet Specifications |  |
|-------------------------|--|
| Port Name               | ETHERNET   |
| Description             | Standard transformer isolated Ethernet port with built-in surge protection for programming, online monitoring, Email (SMTP client), Modbus/TCP client/server connections (fixed IP or DHCP), EtherNet/IP scanner/apapter, custom protocol over Ethernet, ProNET, MQTT/MQTTS. |
| Transfer Rate           | 10 Mbps and 100 Mbps (auto-crossover).   |
| Port Status LED         | LINK (Amber LED) is solid when network LINK is established. ACT (Green LED) flashes when port is active.   |

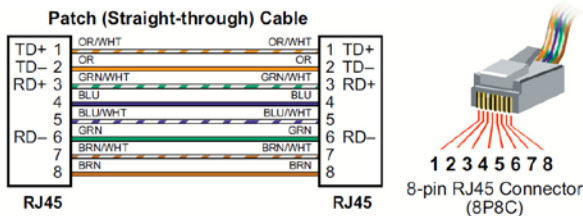
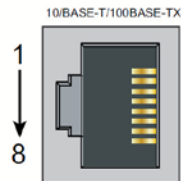

## P1-M622 Ethernet Port

RJ-45 style connector used for the following:

- Connection to a PC running the ProductivitySuite programming software
- Modbus TCP Client connections (Modbus requests sent from the CPU)
- Modbus TCP Server connections (Modbus requests received by the CPU)
- EtherNet/IP (Client/Server)
- Custom Protocol over Ethernet (CPoE)
- ProNET
- MQTT/MQTTS
- Outgoing Email

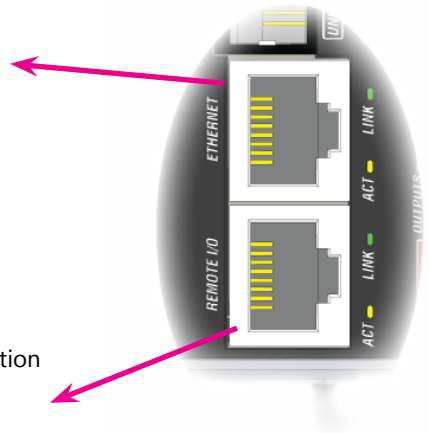

Remote I/O (Lower RJ-45 port):

- 16 GS Drives (GS drive requires communication module/card)
- 4 ProtosX TC Couplers
- 4 P1-RX remote bases
- 1 PS-AMC module

| Ethernet Specifications |  |   |
|-------------------------|--|---|
| Port Name               | Ethernet   | Remote I/O  |
| Description             | Standard transformer-isolated Ethernet port with built-in surge protection for programming, online monitoring, Email (SMTP client), Modbus/TCP client/server connections (fixed IP or DHCP), EtherNet/IP Scanner/Adapter, Custom Protocol over Ethernet, ProNET, and MQTT/MQTTS connections. | Standard transformer-isolated Ethernet port with built-in surge protection for connection to 16 GS Series Drives, or 4 P1-RX modules, or 4 ProtosX TCP couplers, and/or one PS-AMC module |
| Transfer Rate           | 10 Mbps (Orange LED) and 100 Mbps (Green LED) (auto-crossover)   |   |
| Port Status LED         | LINK (Amber LED) is solid when network LINK is established. ACT (Green LED) flashes when port is active  |   |

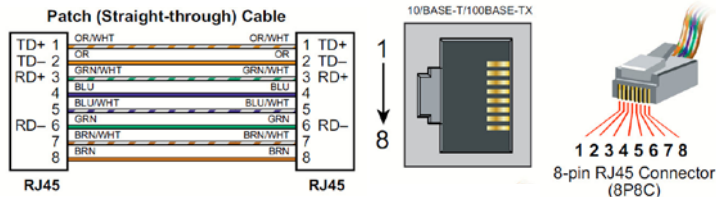

# P1 Mini PLC Specifications

## P1-Mxxx PLC Common Specifications

Each Mini PLC module is similar with respect to general specifications. The table below reflects these common module parameters for both the discrete and analog versions.

| P1 Mini PLC Modules Common Specifications |  |
|---|--|
| Operating Temperature                     | 0° to 60°C (32° to 140°F)  |
| Storage Temperature                       | -20° to 70°C (-4° to 158°F)  |
| Humidity                                  | 5 to 95% (non-condensing)  |
| Altitude                                  | 2000 m max.  |
| Pollution Degree                          | 2  |
| Environmental Air                         | No corrosive gases permitted   |
| Vibration                                 | IEC60068-2-6 (Test Fc)   |
| Shock                                     | IEC60068-2-27 (Test Ea)  |
| Overvoltage Category                      | II   |
| Field to Logic Side Isolation             | 1800 VAC applied for 1 second  |
| Field to Field Isolation                  | N/A  |
| Insulation                                | >10 MΩ @ 500 VDC   |
| Enclosure Type                            | Open equipment   |
| Module Location                           | Controller in a Productivity1000 System.   |
| Field Wiring                              | Use ZIPLink Wiring System or removable terminal block (sold separately).   |
| Terminal Type (sold separately)           | 18-position removable terminal block:<br>P1-Mxx -12DRS, -16DR, -15DD2  |
| Agency Approvals                          | UL 61010-1 and UL 61010-2-201 File E139594, Canada & USA<br>CE (EN 61131-2 EMC, EN 61010-1 and EN 61010-2-201 Safety)* |

\*Note: See CE Declaration of Conformance for Details.

The P1-Mxxx-12DRS module has two parameters that are different than the other modules.

| P1-Mxxx-12DRS PLC Common Specifications |   |
|---|---|
| Field- to Logic-Side Isolation          | Relays to backplane: 2.7 kVAC for 5 s or 800 VAC for 1 min.<br>Discrete Input to backplane: 1.25 kVAC for 5 s or 300 VAC for 1 min. |
| Field to Field Isolation                | Discrete Input to relay C1: 1.35 kVAC for 5 s or 400 VAC for 1 min.<br>Relay to Relay: 1.35 kVAC for 5 s or 400 VAC for 1 min.      |



# P1 Mini PLC Discrete Modules

The table below lists the input and output specifications common to the P1-M401 series, P1-M412 series, and P1-M622 series discrete Mini PLC modules.

| Input Specifications    |                         |                     |                           |                                     |
|-------------------------|-------------------------|---------------------|---------------------------|-------------------------------------|
| Module                  | P1-Mxxx-12DRS*          | P1-Mxxx-16DR*       | P1-Mxxx-15DD2             | P1-Mxxx-16ND3                       |
| Inputs per Module       | 8 (sink/source)         | 8 (sink/source)     | 8 (sink/source)           | 16 (sink/source)                    |
| Rated Voltage           | 24 VAC/DC               |                     | 12–24 VDC                 |                                     |
| Operating Voltage Range | 20.4–27.6 VAC/VDC       |                     | 10.2–26.4 VDC, max 30 VDC |                                     |
| Peak Voltage Range      | 27.6 VAC / 30 VDC       | N/A                 |                           |                                     |
| AC Frequency            | 47–63 Hz                |                     | N/A                       |                                     |
| Input Current           | 8mA @ 24 VAC/VDC        |                     | 8.4 mA @ 24 VDC           | 3.5 mA @ 12 VDC,<br>7.5 mA @ 24 VDC |
| Maximum Input Current   | 10mA @ 27.6 VAC, 30 VDC |                     | 10 mA @ 26.4 VDC          |                                     |
| Input Impedance         | 3 kΩ                    | N/A                 | 3 kΩ                      |                                     |
| Minimum ON Current      | 2.5 mA                  |                     | 1.4 mA                    | 2 mA                                |
| Maximum OFF Current     | 0.5 mA                  |                     | 1 mA                      | 1.6 mA                              |
| ON Voltage Level        | >9.5 VDC, >8VAC         |                     | > 9 VDC                   |                                     |
| OFF Voltage Level       | <4.5 VDC, <4VAC         |                     | < 4.5 VDC                 |                                     |
| Off to On Response      | AC: 10 ms DC: 6 ms      |                     | 2 ms max, 1 ms typical    |                                     |
| On to Off Response      | AC: 20 ms DC: 10 ms     |                     | 2 ms max, 1 ms typical    |                                     |
| Status Indicators       | Logic Side (8 points)   |                     | Logic side (8 points)     | Logic side (16 points)              |
| Commons                 | 2 (4 points/common)     | 1 (8 points/common) | 1 (8 points/common)       | 2 (8 points/common)<br>Isolated     |

| Output Specifications          |  |   |   |
|--------------------------------|--|---|---|
| Module                         | P1-Mxxx-12DRS*   | P1-Mxxx-16DR*   | P1-Mxxx-15DD2   |
| Outputs per Module             | 4  | 8   | 7 (sourcing)  |
| Rated Voltage                  | 6–30 VDC, 6-120 VAC  |   | 12–24 VDC   |
| Operating Voltage Range        | 5–30 VDC, 5-144 VAC  |   | 10.2–28.8 VDC   |
| Output Type                    | Relay, Form A (SPST)   |   | N/A   |
| AC Frequency                   | 47–63 Hz   |   | N/A   |
| Maximum Output Current         | 5A / point (see Temperature Derating Chart)<br>2A / point if used with ZIPLink cable | 1A / point, 8A / common for both AC and DC<br>1A / point, 4A / common for both if used with ZIPLink cable | 1A per point  |
| Minimum Load Current           | 5mA @ 5VDC   |   | 1mA   |
| Maximum Inrush Current         | 5A for 10ms  |   | N/A   |
| Maximum Leakage Current        | N/A  |   | 0.3 mA @ 28.8 VDC   |
| On Voltage Drop                | N/A  |   | 0.2 VDC @ 1A  |
| Maximum Inrush Current         | 5A for 10ms  |   | 4A for 50ms<br>6A for 10ms  |
| OFF to ON, ON to OFF Response  | ≤10 ms   |   | 0.5 ms  |
| Status Indicators              | Logic Side (4 points)  | Logic side (8 points)   | Logic side (7 points)   |
| Commons                        | 4 (1 points/common)  | 1 (8 points/common)   | 1 (7 points/common)   |
| Protection Circuit             | Not built into module – Install protection elements such as external fuse - 8A.      |   | Not built into module – Install protection elements such as an external fuse. |
| External Power Supply Required | N/A  |   | 12–24 VDC<br>(-15% / +20%) @ 22mA   |

\* Refer to page 2-40 for insulation and derating information for the P1-Mxxx-12DRS and P1-Mxxx-16DR Inputs and Outputs

## P1 Mini PLC Insulation Requirements

Following are insulation requirements per IEC/UL 61010-1 and 61010-2-201 (Sections 6.5 and 6.7) common to the P1-Mxxx 12DRS and P1-Mxxx-16DR series Mini PLC modules.

### Input to Output Insulation

Basic insulation is provided between C1 of **relay outputs** and the closest input terminal. When connecting the **relay output** to a circuit that exceeds 100 VAC more than the closest **input circuit** an additional basic insulation layer must be added to the **input circuit**.

### Output to Output Insulation

Basic insulation is provided between **relay outputs**. When connecting the **relay output** to a circuit that exceeds 100 VAC more than the closest **input circuit**, an additional basic insulation layer must be added to the adjacent **relay output** circuits.

### Additional Basic Insulation Examples

**Supplementary insulation:** Interposing relay, additional insulating material (sec. 6.5.3)

**Automatic disconnection of the supply:** Properly sized breaker (sec. 6.5.5)

**Current or voltage Limiting device:** Properly sized fuse (sec. 6.5.6)

Basic insulation requires a clearance distance of 1mm or more, a creepage distance of 1.48 mm or more, and dielectric voltage withstand of 1350  $V_{rms}$ .

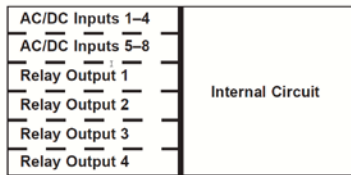

--- Basic Insulation  
 \_\_\_\_\_ Reinforced Insulation  
**P1-Mxxx 12DRS**

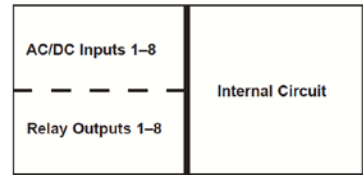

--- Basic Insulation  
 \_\_\_\_\_ Reinforced Insulation  
**P1-Mxxx-16DR**

## Input and Output Derating Charts (P1-Mxxx-12DRS only)

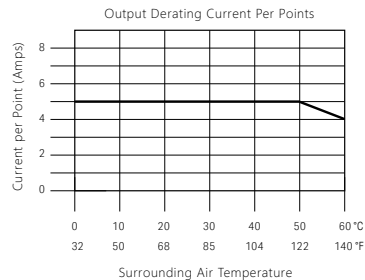
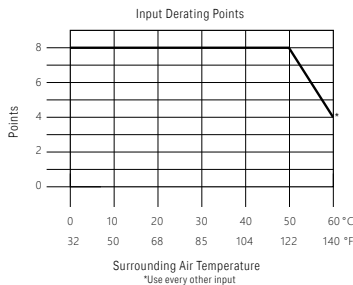

# P1 Mini PLC Analog Modules Input Specifications

The table below lists the input specifications common to the P1-M412 series and P1-M622 series Mini PLC analog modules.

| Input Specifications                  |   |  |  |
|---------------------------------------|---|--|--|
| Module                                | P1-Mxxx-08ADL-1   | P1-Mxxx-4ADL2DAL-1                                     | P1-Mxxx-04THM  |
| Input channels                        | 8   | 4  | 4 differential   |
| Module Signal Input Range             | 0-20 mA   |  | N/A  |
| Signal Resolution                     | 13-bit  |  | 16-bit, $\pm 0.1$ °C or °F   |
| Resolution value of LSB               | 0-20 mA = 2.44 $\mu$ A per count                        |  | N/A  |
| Data Range                            | 0-8191 counts   |  | Floating point   |
| Input Type                            | Sinking, single-ended (1 common)                        |  | N/A  |
| Maximum Continuous Overload / Ratings | $\pm 31$ mA   |  | Fault-protected inputs to $\pm 50$ V   |
| Input Impedance                       | 243 $\Omega$ $\pm 1\%$ , 1/8 W current input            |  | >5 M $\Omega$  |
| Filter Characteristics                | low-pass, -3dB @ 120 Hz                                 |  | N/A  |
| Sample Duration Time                  | 2 ms per channel (does not include ladder scan time)    | 4 ms per channel (does not include ladder scan time)   | 270ms  |
| All Channel Update Rate               | 20 ms   |  | 1.08 s   |
| Open Circuit Detection Time           | Zero reading within 100 ms                              |  | Within 5 s   |
| Conversion Method                     | Successive approximation                                |  | Sigma-Delta  |
| Accuracy vs. Temperature              | $\pm 75$ ppm / °C maximum                               |  | $\pm 50$ ppm per °C (maximum)  |
| Maximum Inaccuracy                    | 0.5% of range (including temperature drift)             |  | $\pm 3$ °C max (excluding thermocouple error)  |
| Linearity Error                       | $\pm 0.037\%$ of range; monotonic with no missing codes |  | $\pm 1$ °C maximum ( $\pm 0.5$ °C typical) Monotonic with no missing codes   |
| Input Stability and Repeatability     | $\pm 0.024\%$ of range                                  |  | N/A  |
| Max Full Scale Calibration Error      | $\pm 0.098\%$ of range                                  |  | N/A  |
| Max Offset Calibration Error          | $\pm 0.098\%$ of range                                  |  | N/A  |
| Max Crosstalk at DC                   | $\pm 0.049\%$ of range                                  |  | N/A  |
| Recommended External Fuse             | Edison S500-32-R 0.032 A fuse                           |  | N/A  |
| External Power Supply Required        | 24 VDC (-20% / + 25%),<br>30 mA                         | 24 VDC (-20% / + 25%),<br>140 mA (loop power included) | None   |
| Common Mode Range                     |   |  | $\pm 0.5$ V  |
| Common Mode Rejection                 |   |  | 100dB @ DC   |
| Warm-up time                          |   |  | 30 min. for $\pm 1\%$ repeatability<br>2 min. to reach voltage specifications  |
| Cold Junction Compensation            |   |  | Automatic  |
| Thermocouple Linearization            |   |  | Automatic  |
| Thermocouple Input Ranges             |   |  | Type J -190° to 760°C (-310° to 1400°F)<br>Type E -210° to 1000°C (-346° to 1832°F)<br>Type K -150° to 1372°C (-238° to 2505°F)<br>Type R 65° to 1768°C (149° to 3214°F)<br>Type S 65° to 1768°C (149° to 3214°F)<br>Type T -230° to 400°C (-382° to 752°F)<br>Type B 529° to 1820°C (984° to 3308°F)<br>Type N -70° to 1300°C (-94° to 2372°F)<br>Type C 65° to 2320°C (149° to 4208°F) |

# P1 Mini PLC Analog Modules Output Specifications

The table below lists the input specifications common to the P1-M412 series and P1-M622 series Mini PLC analog modules.

| Output Specifications                           |   |
|---|---|
| Module  | P1-Mxxx-4ADL2DAL-1  |
| Output per Module                               | 2   |
| Output Range                                    | 4-20 mA   |
| Signal Resolution                               | 12-bit  |
| Resolution value of LSB (least significant bit) | 4–20 mA = 3.9 $\mu$ A / count<br>1 LSB = 1 count  |
| Data Range                                      | 0–4095 counts   |
| Output Type                                     | Current sourcing at 20 mA max.  |
| Output Value in Fault Mode                      | Less than 4mA   |
| Load Impedance                                  | 0–570 $\Omega$ (19.2 VDC), 0–690 $\Omega$ (21.6 VDC),<br>0–810 $\Omega$ (24.0 VDC), 0–930 $\Omega$ (26.4 VDC),<br>0–1100 $\Omega$ (30.0 VDC)<br>Minimum Load: 0 $\Omega$ @ 0–45 $^{\circ}$ C<br>125 $\Omega$ @ 45–60 $^{\circ}$ C ambient temperature |
| Maximum Inductive Load                          | 1mH   |
| Allowed Load Type                               | Grounded  |
| Maximum Inaccuracy                              | 1% of range   |
| Full Scale Calibration Error                    | $\pm$ 0.2% of range minimum   |
| Offset Calibration Error                        | $\pm$ 0.2% of range maximum   |
| Accuracy vs. Temperature                        | $\pm$ 75PPM / $^{\circ}$ C maximum full-scale calibration change ( $\pm$ 0.005% of range / $^{\circ}$ C)  |
| Max Crosstalk at DC, 50Hz and 60Hz              | -72dB, 1 LSB  |
| Linearity Error (End to End)                    | $\pm$ 4 counts max., ( $\pm$ 0.1% of full scale)  |
| Output Stability and Repeatability              | $\pm$ 0.2% counts after 10 min. warmup (typical)  |
| Output Ripple                                   | $\pm$ 0.2% of full range  |
| Output Settling Time                            | 0.3 ms max., 5 $\mu$ s min. (full scale range)  |
| All Channel Update Rate                         | 4ms (max.)  |
| Maximum Continuous Overload                     | Outputs open circuit protected  |
| Type of Output Protection                       | Electronically current limited to 20 mA or less   |
| Output Signal at Power-up and Power-down        | 4mA   |

# Remote Slave Module

## P1-RX Remote Slave Module

The P1-RX is a high performance Remote Slave module. The P1-RX may be connected to a P1-550 CPU or a P2000 CPU for a remote I/O network.

- P1000 CPUs support up to four P1-RX remote slaves.
- Each P1-RX module supports up to eight I/O modules.

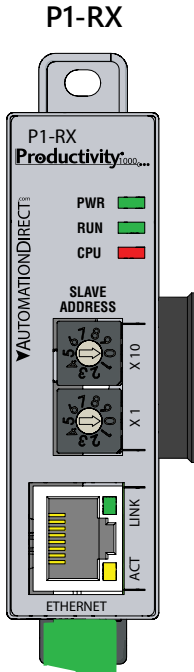

**IMPORTANT!**



### Hot-Swapping Information

Note: This device cannot be Hot Swapped.



### Remote Slave Specifications

|  |  |
|--|--|
| Communications                           | Remote I/O: (10/100M bps Ethernet)   |
| Max. Number of Ethernet Remote I/O Bases | 4 - P1000 CPU (with Remote I/O Ethernet port)<br>8 - P2000 CPU (with Remote I/O Ethernet port)   |
| Max. Number of I/O per CPU System        | P1000 - 512 (4 slaves, 8 slots each, 16 point I/O)<br>P2000 - 1024 (8 slaves, 8 slots each, 16 point I/O)  |
| Max. I/O Modules per P1-RX               | 8 Modules  |
| External Power Required                  | 24 VDC±2% @ 5 W plus 1.25 W per additional I/O module. (See page 2-5 for power supply options)<br>External fuse is required when using external power supply, the recommended fuse is:<br>Edison S5061-R, Time Delay, 1 A Fuse (8 I/O Modules) |

### General Specifications

|                       |  |
|-----------------------|--|
| Operating Temperature | 0°–60°C (32°–140°F)  |
| Storage Temperature   | -20°–70°C (-4°–158°F)  |
| Humidity              | 5 to 95% (non-condensing)  |
| Environmental Air     | No corrosive gases permitted   |
| Vibration             | IEC60068-2-6 (Test Fc)   |
| Shock                 | IEC60068-2-27 (Test Ea)  |
| Heat Dissipation      | 1670 W   |
| Enclosure Type        | Open equipment   |
| Weight                | 82 g (2.9 oz)  |
| Agency Approvals      | UL 61010 and UL 61010-2-201 file E139594, Canada & USA<br>CE (EN61131-2 EMC, EN6 1010-1 and EN61010-2-201 Safety)* |

\*See CE Declaration of Conformance for details.

### RX Status Indicators

|     |   |
|-----|---|
| PWR | Green LED is backlit when power is on   |
| RUN | Green LED is backlit to indicate when CPU has valid project file with RX configured |
| CPU | Red LED is backlit during power on reset, power down, or watch-dog time-out         |

### P1-RX Power Terminal

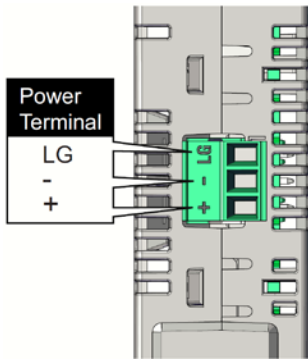

P1-RX  
Bottom View

### Removable Terminal Block Specifications

|                     |   |
|---------------------|---|
| Part Number         | PCON-KIT  |
| Number of Positions | 3 screw terminals   |
| Pitch               | 3.5 mm  |
| Wire Range          | 28–16 AWG solid conductor<br>28–16 AWG stranded conductor |
| Screw Driver        | 0.125 inch (3.175 mm) maximum                             |
| Screw Size          | M2  |
| Screw Torque        | 1.7 lb-in (0.4 N·m)                                       |

*NOTE: See page 2-5 for power supply options. Power to the P1-RX and connected modules will be supplied by EITHER a P1 power supply module connected to the left of the P1-RX OR by an external 24 VDC power supply connected to the terminals at the bottom of the CPU. Only one of these sources shall be connected.*

| Pin | Signal   |
|-----|----------|
| LG  | Ground   |
| -   | 24 VDC - |
| +   | 24 VDC + |

Removable connector included. Spare connectors available (part no. PCON-KIT).

### P1-RX Remote I/O Example

Add up to 8 remote bases using P2000 CPUs and up to 4 remote bases for P1-550 along with other supported devices on the remote I/O Ethernet network

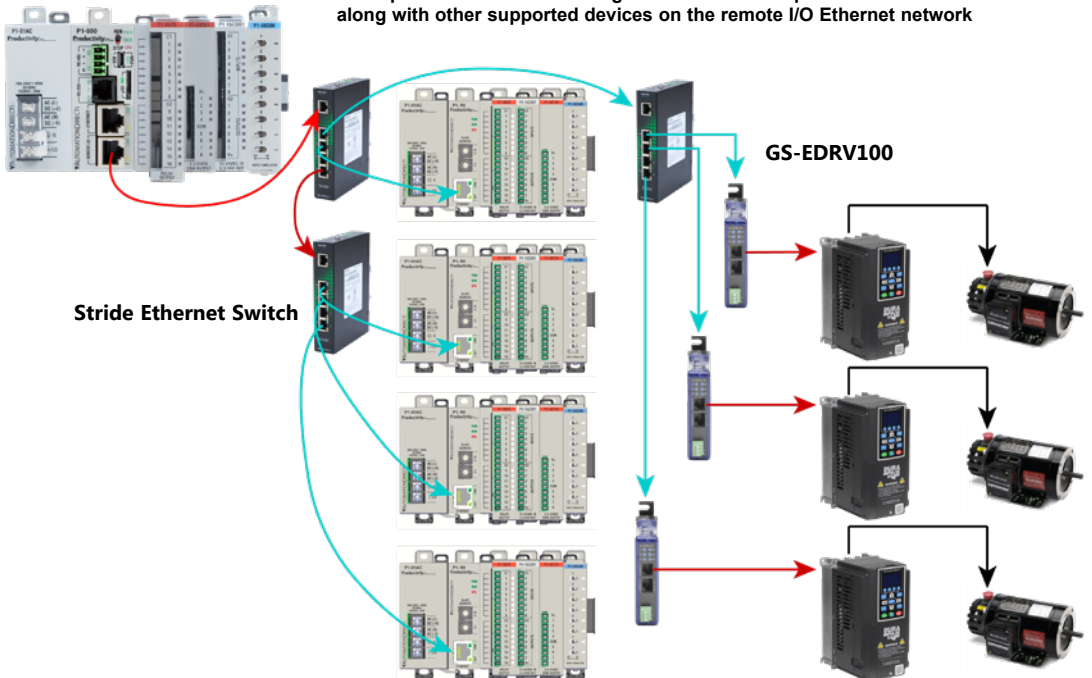

### P1-RX Setting Remote Slave Address

Each Remote Slave must have a unique address between 1 and 99. The address is set using the two rotary switches located in the base; X10 for setting the tens digit and X1 for setting the ones digit.

For example, to set a remote slave address to 26, turn the X10 arrow until it points at the number 2 and the X1 arrow until it points at the number 6.

#### IMPORTANT NOTES:

- The factory setting of 00 is not a valid address for the Remote Slave.
- Address selection must be set prior to power-up.
- Slave addresses are read only on power-up.
- If there are duplicate P1-RX slave addresses on the same network, a critical error will be displayed on the CPU.

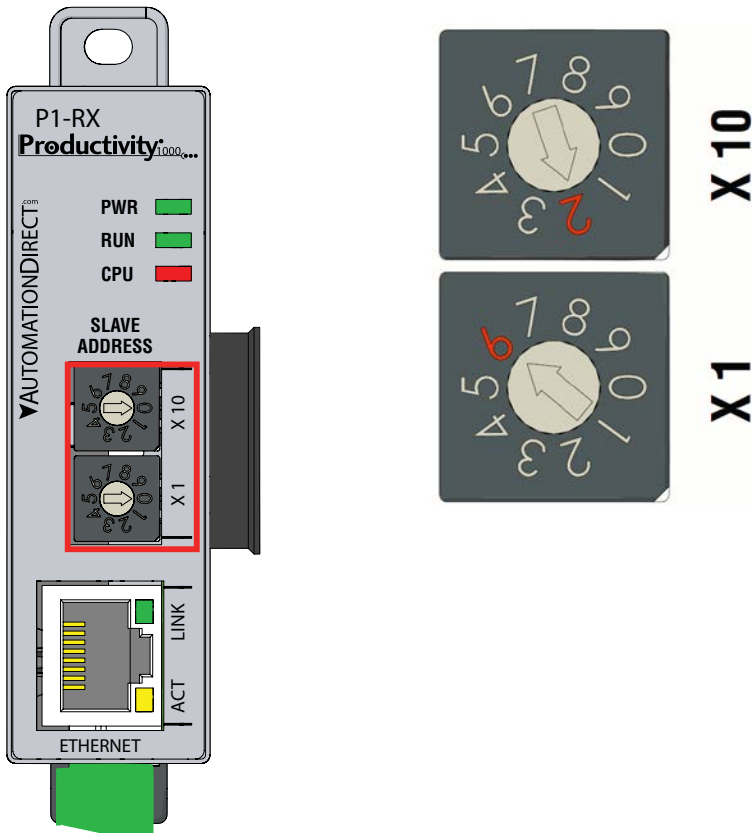

## P1-RX Remote I/O Port

Isolated Ethernet Port with built-in surge protection for connection to the CPU Remote I/O Master port.

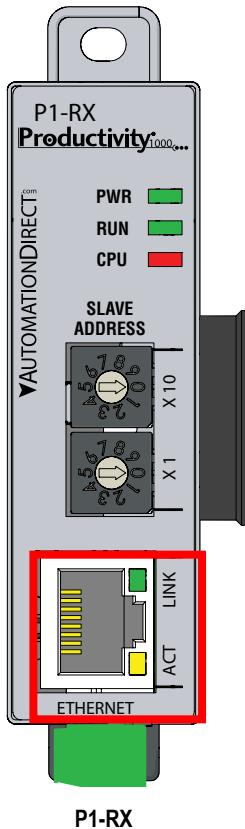

| Remote I/O Port Specifications |  |
|--------------------------------|--|
| Port Name                      | Ethernet   |
| Description                    | Proprietary transformer isolated Ethernet Port built-in surge protection for connection to CPU Remote I/O Master port. |
| Transfer Rate                  | 10/100 Mbps  |
| Port Status LEDs               | Green LED is illuminated when network LINK is established. Yellow LED is backlit when port is active (ACT).            |
| Cables                         | Auto crossover port allows use of a straight-through or crossover cable  |

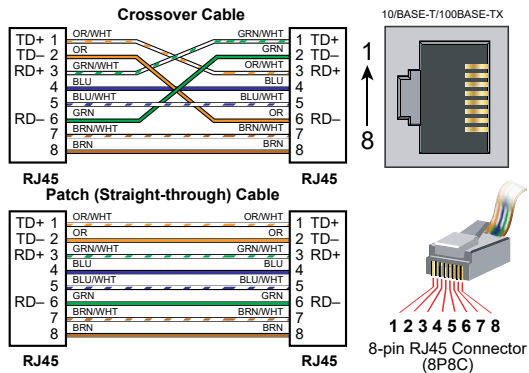

# I/O Modules Overview

A variety of discrete and analog I/O modules are available for use in the P1000 system. Each I/O module is identified as an "Input", "Output", or "Input/Output" module on its front panel using the color coding scheme listed below. See the following pages for discrete I/O module specifications and Chapter 3 for analog I/O modules and Chapter 4 for specialty module specifications.

Discrete Input Modules

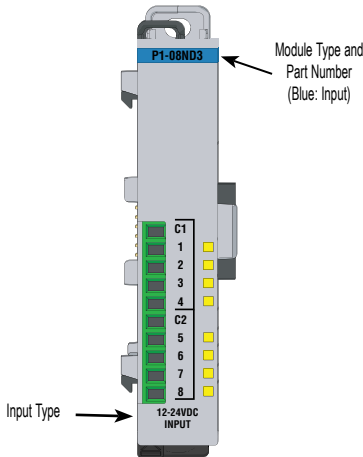

Discrete Output Modules

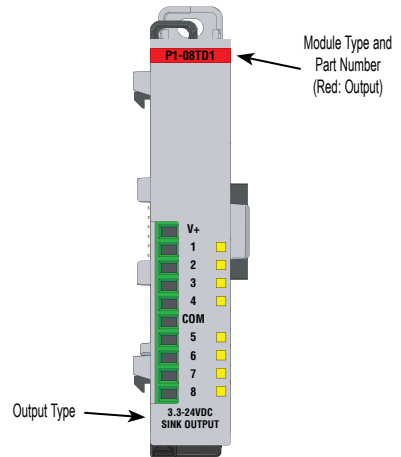

Analog Input Modules

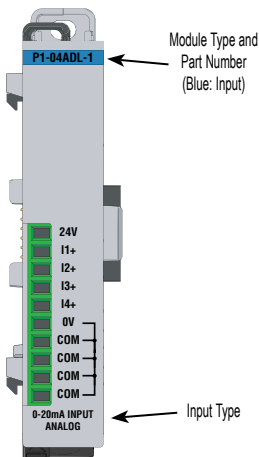

Analog Output Modules

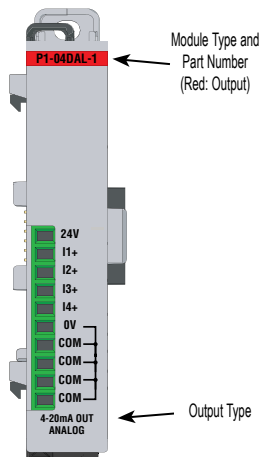

Discrete Input/Output Modules

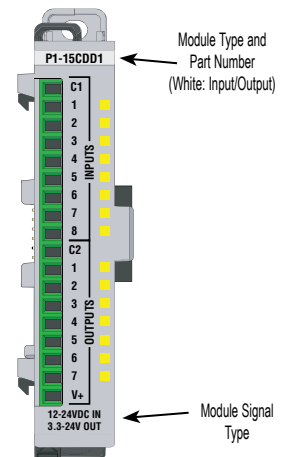

# Discrete I/O Modules

## Discrete Input Modules

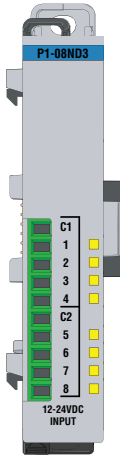

| Productivity1000 Discrete Input Modules |                  |                                  |          |
|---|------------------|----------------------------------|----------|
| Part Number                             | Number of Inputs | Description                      | See Page |
| P1-08SIM                                | 8                | Input Simulator Module           | 2-71     |
| P1-08ND-TTL                             | 8                | Sinking/Sourcing 3–5 VDC Input   | 2-72     |
| P1-08ND3                                | 8                | Sinking/Sourcing 12–24 VDC Input | 2-75     |
| P1-16ND3                                | 16               | Sinking/Sourcing 12–24 VDC Input | 2-78     |
| P1-08NE3                                | 8                | Sinking/Sourcing 24V AC/DC       | 2-81     |
| P1-16NE3                                | 16               | Sinking/Sourcing 24V AC/DC       | 2-84     |
| P1-08NA                                 | 8                | AC Isolated 100–240 VAC          | 2-87     |

## Discrete Output Modules

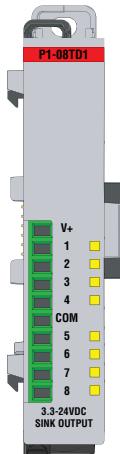

| Productivity1000 Discrete Output Modules |                   |                       |          |
|--|-------------------|-----------------------|----------|
| Part Number                              | Number of Outputs | Description           | See Page |
| P1-08TD-TTL                              | 8                 | Sourcing DC Output    | 2-90     |
| P1-08TD1                                 | 8                 | Sinking DC Output     | 2-63     |
| P1-08TD2                                 | 8                 | Sourcing DC Output    | 2-96     |
| P1-15TD1                                 | 15                | Sinking DC Output     | 2-99     |
| P1-15TD2                                 | 15                | Sourcing DC Output    | 2-102    |
| P1-08TA                                  | 8                 | AC Output             | 2-105    |
| P1-04TEPS                                | 4                 | Isolated Output       | 2-108    |
| P1-04TRS                                 | 4                 | Isolated Relay Output | 2-111    |
| P1-08TRS                                 | 8                 | Isolated Relay Output | 2-114    |
| P1-16TR                                  | 16                | Relay Output          | 2-117    |

# Discrete Combo I/O Modules

## Discrete Combo Input/Output Modules

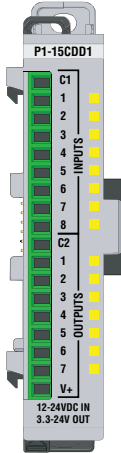

| Productivity1000 Discrete Combo Modules |        |         |  |          |
|---|--------|---------|--|----------|
| Part Number                             | Inputs | Outputs | Description                                  | See Page |
| P1-12CDRS                               | 8      | 4       | Input: Sinking/Sourcing;<br>Output: Relay    | 2-120    |
| P1-15CDD1                               | 8      | 7       | Input: Sinking/Sourcing;<br>Output: Sinking  | 2-124    |
| P1-15CDD2                               | 8      | 7       | Input: Sinking/Sourcing;<br>Output: Sourcing | 2-127    |
| P1-16CDR                                | 8      | 8       | Input: Sinking/Sourcing;<br>Output: Relay    | 2-130    |

## I/O Modules Installation

A variety of discrete and analog I/O modules can be added to the P1000 PLC to create a custom control system. To add an I/O module (verify field power is not energized), with the latch in “locked” position, align connectors on the side of each module and press together. An audible click indicates the module lock is engaged. Verify each connecting module tab is firmly in the locked position.

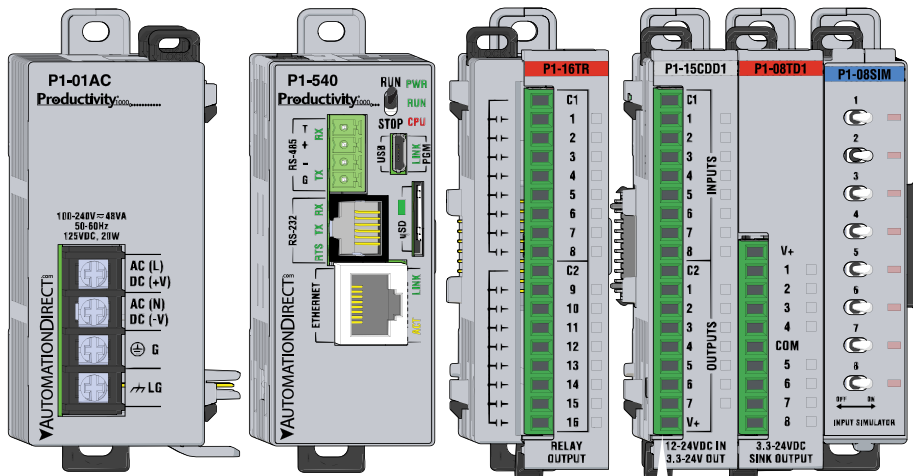

# P1-08SIM Input Simulator Module

The P1-08SIM Input Simulator Module provides 8 toggle switches to simulate input devices.

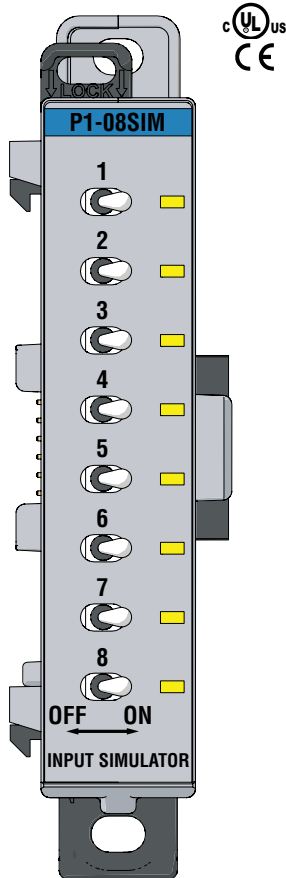

## Input Specifications

|                    |                       |
|--------------------|-----------------------|
| Inputs per Module  | 8 Internal switches   |
| OFF to ON Response | Max. 20 ms            |
| ON to OFF Response | Max. 20 ms            |
| Status Indicators  | Logic Side (8 points) |

## General Specifications

|                           |  |
|---------------------------|--|
| Operating Air Temperature | 0°C–60°C (32°F–140°F)  |
| Storage Temperature       | -20°C–70°C (-4°F–158°F)  |
| Humidity                  | 5 to 95% (non-condensing)  |
| Environmental Air         | No corrosive gases permitted   |
| Vibration                 | IEC60068-2-6 (Test Fc)   |
| Shock                     | IEC60068-2-27 (Test Ea)  |
| Heat Dissipation          | 200 mW   |
| Enclosure Type            | Open equipment   |
| Module Location           | Any I/O slot in a Productivity®1000 system.  |
| Weight                    | 70 g (2.5 oz)  |
| Agency Approvals          | UL 61010-1 and UL 61010-2-201 File E139594, Canada and USA<br>CE (EN 61131-2 EMC, EN 61010-1 and EN 61010-2-201 Safety)* |

\* See CE Declaration of Conformity for details. See the D.O.C. for details.

# P1-08ND-TTL DC Input

The P1-08ND-TTL Input Module provides eight inputs for TTL level devices for use with the Productivity1000 system.

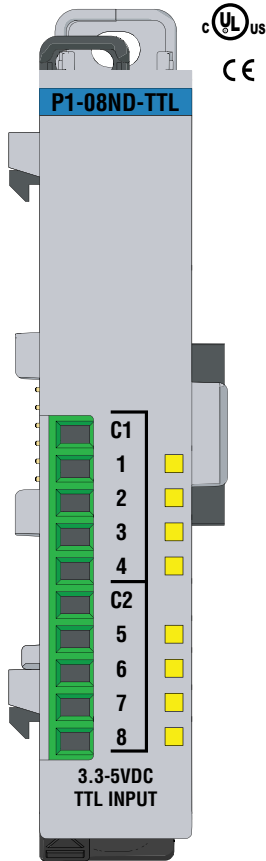

| Input Specifications          |                                |
|-------------------------------|--------------------------------|
| Inputs per Module             | 8 (sinking/sourcing)           |
| Rated Voltage                 | 3.3 - 5 VDC                    |
| Operating Voltage Range       | 3.3 - 5 VDC $\pm 10\%$         |
| Input Current                 | 6 mA @ 3.3 VDC<br>8 mA @ 5 VDC |
| Maximum Input Current         | 8 mA @ 5.5 VDC                 |
| Input Impedance               | 820 $\Omega$                   |
| Minimum ON Current            | 1.4 mA                         |
| Maximum OFF Current           | 1 mA                           |
| ON Voltage Level              | > 2.2 VDC                      |
| OFF Voltage Level             | < 0.8 VDC                      |
| OFF to ON, ON to OFF Response | 2 ms maximum, 1 ms typical     |
| Status Indicators             | Logic Side (8 points)          |
| Commons                       | 2 (4 points/common)            |

| Removable Terminal Block Specifications |   |   |
|---|---|---|
| Part Number                             | P1-10RTB  | P1-10RTB-1  |
| Number of Positions                     | 10 screw terminals  | 10 spring clamp terminals   |
| Wire Range                              | 30–16 AWG (0.051–1.31 mm <sup>2</sup> )<br>Solid/stranded conductor<br>3/64 in. (1.2 mm) insulation max.<br>1/4 in. (6–7 mm) strip length | 28–16 AWG (0.081–1.31 mm <sup>2</sup> )<br>Solid/stranded conductor<br>3/64 in. (1.2 mm) insulation max.<br>19/64 in. (7–8 mm) strip length |
| Conductors                              | USE COPPER CONDUCTORS, 75°C or equivalent.  |   |
| Screw Driver                            | 0.1 inch (2.5 mm) maximum*  |   |
| Screw Size                              | M2  | N/A   |
| Screw Torque                            | 2.5 lb-in (0.28 N-m)  | N/A   |

\* Recommended screw driver: P/N TW-SD-MSL-1

Terminal blocks sold separately



**NOTE:** Module shown with flip-up finger-safe terminal cover removed for clarity.

We recommend using pre-wired ZIPLink cables and connection modules. See Chapter 5. If you wish to hand-wire your module, removable terminal blocks are sold separately. Order part number P1-10RTB or P1-10RTB-1



## P1-08ND-TTL DC Input (continued)

| General Specifications           |  |
|----------------------------------|--|
| Operating Air Temperature        | 0°C– 60°C (32°F–140°F)   |
| Storage Temperature              | -20°C–70°C (-4°F–158°F)  |
| Humidity                         | 5 to 95% (non-condensing)  |
| Altitude                         | 2,000 meters max.  |
| Pollution Degree                 | 2  |
| Environmental Air                | No corrosive gases permitted   |
| Vibration                        | IEC60068-2-6 (Test Fc)   |
| Shock                            | IEC60068-2-27 (Test Ea)  |
| Overvoltage Category             | II   |
| Field to Logic Side Isolation    | 1800 VDC applied for 1 s   |
| Insulation Resistance            | >10 MΩ @ 500 VDC   |
| Heat Dissipation                 | 220 mW   |
| Enclosure Type                   | Open equipment   |
| Module Keying to Backplane       | Electronic   |
| Module Location                  | Any I/O position in a Productivity@1000 system   |
| Field Wiring                     | Use ZIPLink wiring system or removable terminal block (sold separately). See “Wiring Options” in Chapter 5.              |
| Connector Type (sold separately) | 10-position removable terminal block   |
| Weight                           | 55 g (1.9 oz)  |
| Agency Approvals                 | UL 61010-1 and UL 61010-2-201 File E139594, Canada and USA<br>CE (EN 61131-2 EMC, EN 61010-1 and EN 61010-2-201 Safety)* |

\* See CE Declaration of Conformity for details.

# P1-08ND-TTL DC Input (continued)

## Wiring Diagrams

Single Supply

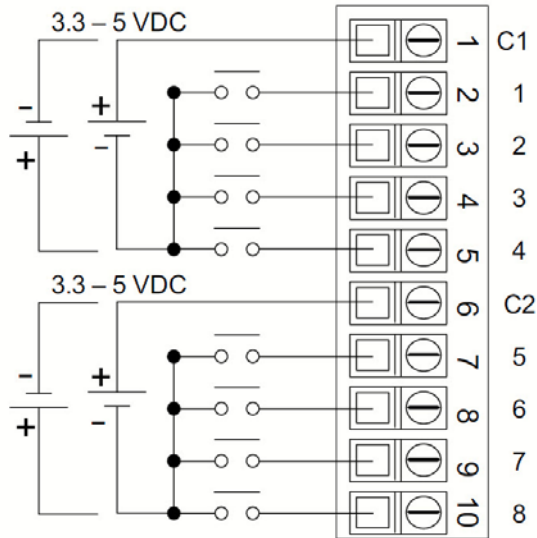

Equivalent Input Circuit

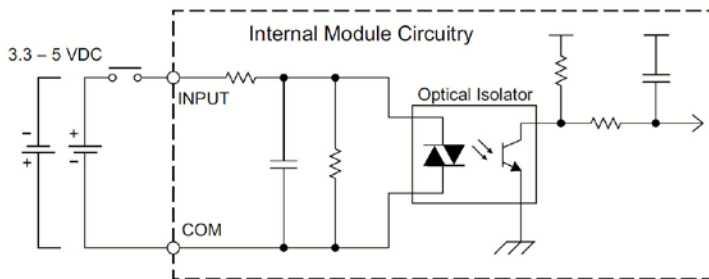

## P1-08ND3 Sinking/Sourcing DC Input

The P1-08ND3 Input Module provides eight inputs for switches and other devices connected to ground or supplies ranging from 12–24 VDC for use with the Productivity1000 system.

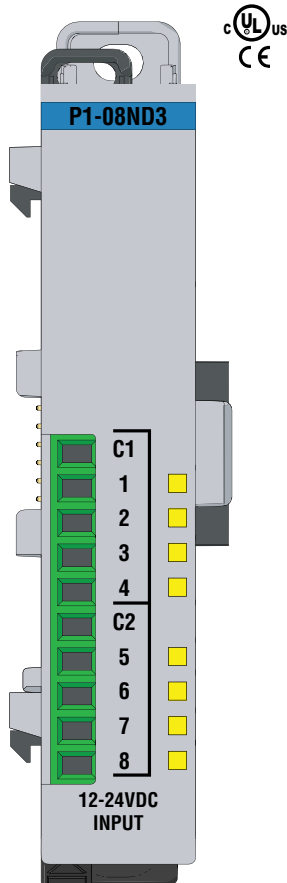

| Input Specifications          |                                    |
|-------------------------------|------------------------------------|
| Inputs per Module             | 8 (Sink/Source)                    |
| External 24VDC Power Required | 12–24 VDC                          |
| Input Voltage Range           | 10.2–26.4 VDC                      |
| Input Current                 | 3.5 mA @ 12 VDC<br>8.4 mA @ 24 VDC |
| Maximum Input Current         | 10 mA @ 26.4 VDC                   |
| Input Impedance               | 3 kΩ                               |
| Minimum ON Current            | 1.4 mA                             |
| Maximum OFF Current           | 1 mA                               |
| ON Voltage Level              | > 9.5 VDC                          |
| OFF Voltage Level             | < 4.5 VDC                          |
| OFF to ON, ON to OFF Response | 2 ms Maximum, 1 ms Typical         |
| Status Indicators             | Logic Side (8 points)              |
| Commons                       | 2 (4 points/common)                |

Terminal blocks sold separately

We recommend using pre-wired ZIPLink cables and connection modules. See Chapter 5. If you wish to hand-wire your module, removable terminal blocks are sold separately. Order part number P1-10RTB or P1-10RTB-1



## P1-08ND3 Sinking/Sourcing DC Input (continued)

| General Specifications           |  |
|----------------------------------|--|
| Operating Air Temperature        | 0°C– 60°C (32°F–140°F),  |
| Storage Temperature              | -20°C–70°C (-4°F–158°F)  |
| Humidity                         | 5 to 95% (non-condensing)  |
| Environmental Air                | No corrosive gases permitted   |
| Vibration                        | IEC60068-2-6 (Test Fc)   |
| Shock                            | IEC60068-2-27 (Test Ea)  |
| Field to Logic Side Isolation    | 1800 VAC applied for 1 s   |
| Insulation Resistance            | >10 MΩ @ 500 VDC   |
| Heat Dissipation                 | 2000 mW  |
| Enclosure Type                   | Open equipment   |
| Module Location                  | Any I/O position in a Productivity1000 system.   |
| Field Wiring                     | Use <b>ZIPLink</b> wiring system or removable terminal block (sold separately). See “Wiring Options” in Chapter 5.       |
| Connector Type (sold separately) | 10-position removable terminal block   |
| Weight                           | 85 g (3oz)   |
| Agency Approvals                 | UL 61010-1 and UL 61010-2-201 File E139594, Canada and USA<br>CE (EN 61131-2 EMC, EN 61010-1 and EN 61010-2-201 Safety)* |

\* See the Declaration of Conformity for details.

| Removable Terminal Block Specifications |   |   |
|---|---|---|
| Part Number                             | P1-10RTB  | P1-10RTB-1  |
| Number of Positions                     | 10 screw terminals  | 10 spring clamp terminals   |
| Wire Range                              | 30–16 AWG (0.051–1.31 mm <sup>2</sup> )<br>Solid/stranded conductor<br>3/64 in. (1.2 mm) insulation max.<br>1/4 in. (6–7 mm) strip length | 28–16 AWG (0.081–1.31 mm <sup>2</sup> )<br>Solid/stranded conductor<br>3/64 in. (1.2 mm) insulation max.<br>19/64 in. (7–8 mm) strip length |
| Conductors                              | USE COPPER CONDUCTORS, 75°C or equivalent.  |   |
| Screw Driver                            | 0.1 inch (2.5 mm) maximum*  |   |
| Screw Size                              | M2  | N/A   |
| Screw Torque                            | 2.5 lb·in (0.28 N·m)  | N/A   |

\* Recommended screw driver: P/N TW-SD-MSL-1.

# P1-08ND3 Sinking/Sourcing DC Input (continued)

## Wiring Diagrams

Single Supply

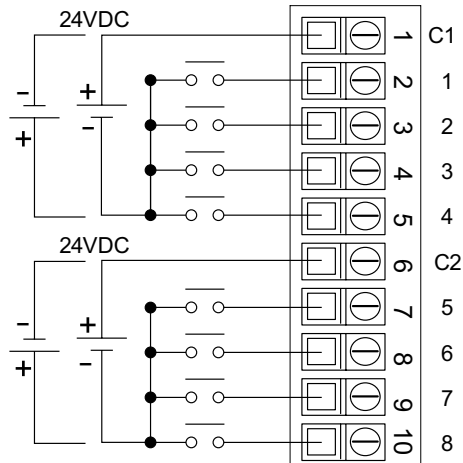

Equivalent Input Circuit

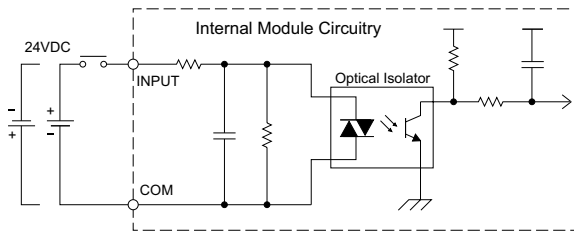

# P1-16ND3 Sinking/Sourcing DC Input

The P1-16ND3 Input Module provides sixteen 12–24 VDC sink/source inputs with two isolated commons for use with the Productivity1000 system.

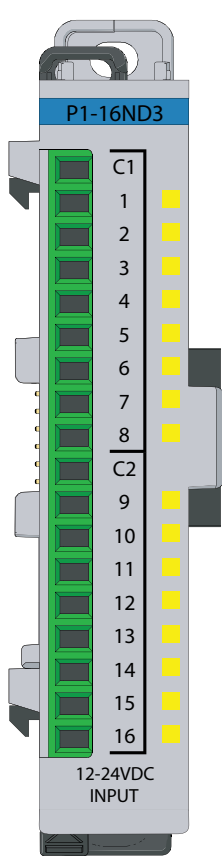

| Input Specifications          |                                  |
|-------------------------------|----------------------------------|
| Inputs per Module             | 16 (Sink/Source)                 |
| Rated Voltage                 | 12–24 VDC                        |
| Operating Voltage Range       | 10.2–26.4 VDC, max 30 VDC        |
| Input Current                 | 3.5 mA @ 12VDC<br>7.5 mA @ 24VDC |
| Maximum Input Current         | 10 mA @ 26.4 VDC                 |
| Input Impedance               | 3 kΩ                             |
| Minimum ON Current            | 2 mA                             |
| Maximum OFF Current           | 1.6 mA                           |
| ON Voltage Level              | >9 VDC                           |
| OFF Voltage Level             | <4.5 VDC                         |
| OFF to ON, ON to OFF Response | 2 ms Maximum, 1 ms typical       |
| Status Indicators             | Logic Side (16 points)           |
| Commons                       | 2 (8 points/common) isolated     |

Terminal blocks sold separately

We recommend using pre-wired ZIPLink cables and connection modules. See Chapter 5. If you wish to hand-wire your module, removable terminal blocks are sold separately. Order part number P2-RTB or P2-RTB-1



## P1-16ND3 Sinking/Sourcing DC Input (continued)

| General Specifications          |  |
|---------------------------------|--|
| Operating Air Temperature       | 0°C–60°C (32°F–140°F),   |
| Storage Temperature             | -20°C–70°C (-4°F–158°F)  |
| Humidity                        | 5 to 95% (non-condensing)  |
| Environmental Air               | No corrosive gases permitted   |
| Vibration                       | IEC60068-2-6 (Test Fc)   |
| Shock                           | IEC60068-2-27 (Test Ea)  |
| Field to Logic Side Isolation   | 1800 VAC applied for 1 s   |
| Insulation Resistance           | >10 MΩ @ 500 VDC   |
| Heat Dissipation                | 3500 mW  |
| Enclosure Type                  | Open equipment   |
| Module Location                 | Any I/O position in a Productivity®1000 system.  |
| Field Wiring                    | Use <b>ZIP</b> Link wiring system or removable terminal block (sold separately). See "Wiring Options" in Chapter 5.      |
| Terminal Type (sold separately) | 18-position removable terminal block   |
| Weight                          | 71 g (2.5 oz)  |
| Agency Approvals                | UL 61010-1 and UL 61010-2-201 File E139594, Canada and USA<br>CE (EN 61131-2 EMC, EN 61010-1 and EN 61010-2-201 Safety)* |

\* See CE Declaration of Conformance for details.

| Removable Terminal Block Specifications |   |   |
|---|---|---|
| Part Number                             | P1-10RTB  | P1-10RTB-1  |
| Number of Positions                     | 10 screw terminals  | 10 spring clamp terminals   |
| Wire Range                              | 30–16 AWG (0.051–1.31 mm <sup>2</sup> )<br>Solid/stranded conductor<br>3/64 in. (1.2 mm) insulation max.<br>1/4 in. (6–7 mm) strip length | 28–16 AWG (0.081–1.31 mm <sup>2</sup> )<br>Solid/stranded conductor<br>3/64 in. (1.2 mm) insulation max.<br>19/64 in. (7–8 mm) strip length |
| Conductors                              | USE COPPER CONDUCTORS, 75°C or equivalent.  |   |
| Screw Driver                            | 0.1 inch (2.5 mm) maximum*  |   |
| Screw Size                              | M2  | N/A   |
| Screw Torque                            | 2.5 lb-in (0.28 N-m)  | N/A   |

\* Recommended screw driver: P/N TW-SD-MSL-1.

# P1-16ND3 Sinking/Sourcing DC Input (continued)

## Wiring Diagrams

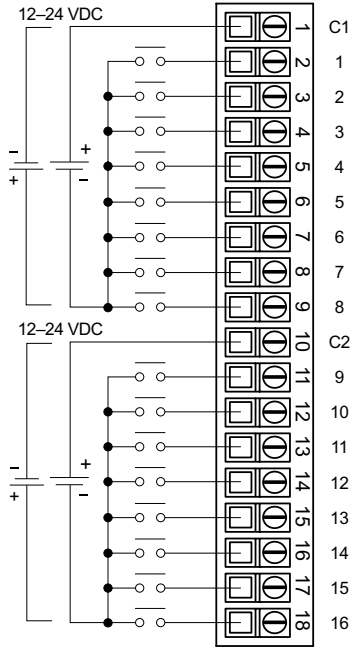

### Equivalent Input Circuit

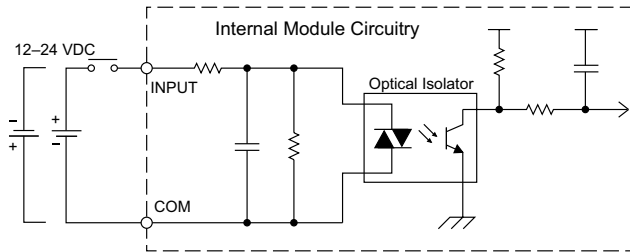

## P1-08NE3 AC/DC Sinking/Sourcing Input

The P1-08NE3 AC/DC Input Module provides eight 24 VAC/VDC sink/source inputs with two isolated commons for use with the Productivity1000 system.

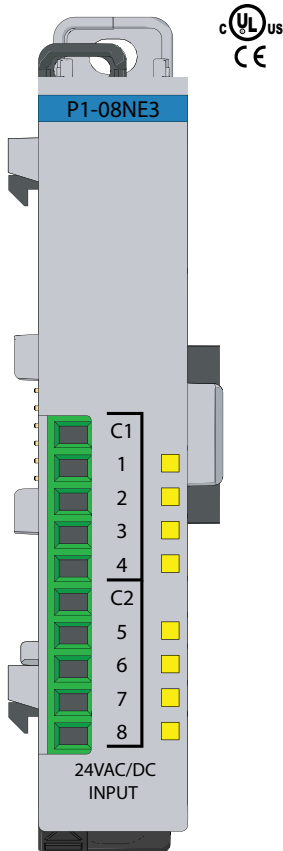

| Input Specifications    |   |
|-------------------------|---|
| Inputs per Module       | 8 (Sink/Source)                             |
| Voltage Range           | 24 VAC/VDC                                  |
| Operating Voltage Range | 20.4–27.6 VAC/VDC,<br>Max. 27.6 VAC, 30 VDC |
| AC Frequency            | 47–63 Hz                                    |
| Input Current (Typical) | 8 mA @ 24 VAC/VDC                           |
| Maximum Input Current   | 10 mA @ 27.6 VAC/VDC                        |
| ON Voltage Level        | >9.5 VDC, >8 VAC                            |
| OFF Voltage Level       | <4.5 VDC, <4 VAC                            |
| Minimum ON Current      | 2.5 mA                                      |
| Maximum OFF Current     | 0.5 mA                                      |
| OFF to ON Response      | AC: 10 ms<br>DC: 6 ms > max                 |
| ON to OFF Response      | AC: 20 ms<br>DC: 10 ms > max                |
| Status Indicators       | Logic Side (8 points)                       |
| Commons                 | 2 (4 points/common) isolated                |

Terminal blocks sold separately

We recommend using pre-wired ZIPLink cables and connection modules. See Chapter 5. If you wish to hand-wire your module, removable terminal blocks are sold separately. Order part number P1-10RTB or P1-10RTB-1



## P1-08NE3 AC/DC Sinking/Sourcing Input, (continued)

| General Specifications           |  |
|----------------------------------|--|
| Operating Air Temperature        | 0°C– 60°C (32°F–140°F),  |
| Storage Temperature              | -20°C–70°C (-4°F–158°F)  |
| Humidity                         | 5 to 95% (non-condensing)  |
| Environmental Air                | No corrosive gases permitted   |
| Vibration                        | IEC60068-2-6 (Test Fc)   |
| Shock                            | IEC60068-2-27 (Test Ea)  |
| Field to Logic Side Isolation    | 1800 VAC applied for 1 s   |
| Insulation Resistance            | >10 MΩ @ 500 VDC   |
| Heat Dissipation                 | 1800 mW  |
| Enclosure Type                   | Open equipment   |
| Module Location                  | Any I/O position in a Productivity1000 system.   |
| Field Wiring                     | Use <b>ZIPLink</b> wiring system or optional terminal block (not included). See "Wiring Options" in Chapter 5.           |
| Connector Type (Sold separately) | 10-position removable terminal block   |
| Weight                           | 70 g (2.5 oz)  |
| Agency Approvals                 | UL 61010-1 and UL 61010-2-201 File E139594, Canada and USA<br>CE (EN 61131-2 EMC, EN 61010-1 and EN 61010-2-201 Safety)* |

\* See CE Declaration of Conformance for details.

| Removable Terminal Block Specifications |   |   |
|---|---|---|
| Part Number                             | P1-10RTB  | P1-10RTB-1  |
| Number of Positions                     | 10 screw terminals  | 10 spring clamp terminals   |
| Wire Range                              | 30–16 AWG (0.051–1.31 mm <sup>2</sup> )<br>Solid/stranded conductor<br>3/64 in. (1.2 mm) insulation max.<br>1/4 in. (6–7 mm) strip length | 28–16 AWG (0.081–1.31 mm <sup>2</sup> )<br>Solid/stranded conductor<br>3/64 in. (1.2 mm) insulation max.<br>19/64 in. (7–8 mm) strip length |
| Conductors                              | USE COPPER CONDUCTORS, 75°C or equivalent.  |   |
| Screw Driver                            | 0.1 inch (2.5 mm) maximum*  |   |
| Screw Size                              | M2  | N/A   |
| Screw Torque                            | 2.5 lb-in (0.28 N-m)  | N/A   |

\* Recommended screw driver: P/N TW-SD-MSL-1.

# P1-08NE3 AC/DC Sinking/Sourcing Input, (continued)

## Wiring Diagrams

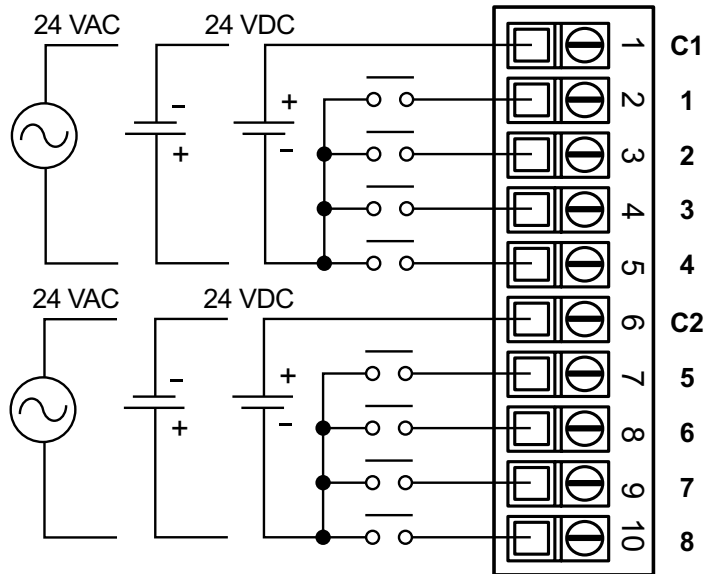

### Equivalent Input Circuit

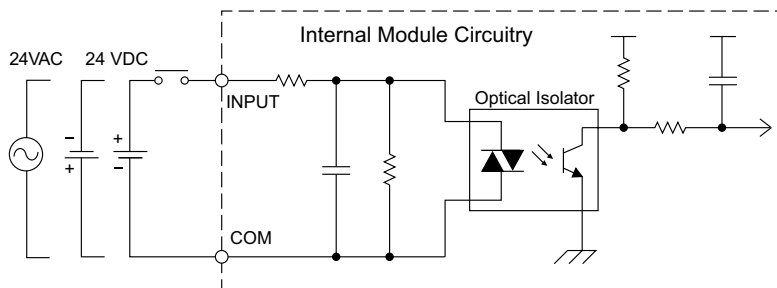

## P1-16NE3 AC/DC Sinking/Sourcing Input

The P1-16NE3 AC/DC Input Module provides sixteen 24VAC or VDC sink/source inputs with two isolated commons for use with Productivity1000 system.

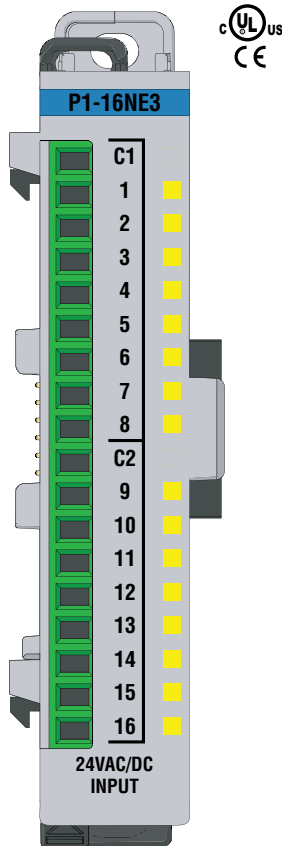

| Input Specifications    |                                   |
|-------------------------|-----------------------------------|
| Inputs per Module       | 16 (Sink/Source)                  |
| Rated Voltage           | 24 VAC/VDC                        |
| Operating Voltage Range | 20.4–27.6 VAC/VDC; Max 30 VAC/VDC |
| AC Frequency            | 47–63 Hz                          |
| Input Current           | 3.4 mA @ 24 VAC/VDC               |
| Maximum Input Current   | 10 mA @ 30 VAC/VDC                |
| ON Voltage Level        | >12 VDC, > 9 VAC                  |
| OFF Voltage Level       | <10.5 VDC, < 9 VAC                |
| Minimum ON Current      | 2.5 mA                            |
| Maximum OFF Current     | 0.5 mA                            |
| OFF to ON Response      | DC: 6 ms > max<br>AC: 10 ms       |
| ON to OFF Response      | DC: 10 ms > max<br>AC: 20 ms      |
| Status Indicators       | Logic side (16 points)            |
| Commons per Module      | 2 (8 points/common) isolated      |

Terminal blocks sold separately

We recommend using pre-wired ZIPLink cables and connection modules. See Chapter 5. If you wish to hand-wire your module, removable terminal blocks are sold separately. Order part number P2-RTB or P2-RTB-1



## P1-16NE3 AC/DC Sinking/Sourcing Input, (continued)

| General Specifications        |  |
|-------------------------------|--|
| Operating Air Temperature     | 0°C– 60°C (32°F–140°F),  |
| Storage Temperature           | -20°C–70°C (-4°F–158°F)  |
| Humidity                      | 5 to 95% (non-condensing)  |
| Environmental Air             | No corrosive gases permitted   |
| Vibration                     | IEC60068-2-6 (Test Fc)   |
| Shock                         | IEC60068-2-27 (Test Ea)  |
| Field to Logic Side Isolation | 1800 VAC applied for 1 s   |
| Insulation Resistance         | >10 MΩ @ 500 VDC   |
| Heat Dissipation              | 2000 mW  |
| Enclosure Type                | Open equipment   |
| Module Location               | Any I/O position in a Productivity1000 system.   |
| Field Wiring                  | Use <b>ZIPLink</b> wiring system or optional terminal block (not included). See "Wiring Options" in Chapter 5.           |
| Connector Type (not included) | 18-position removable terminal block   |
| Weight                        | 71 g (2.5 oz)  |
| Agency Approvals              | UL 61010-1 and UL 61010-2-201 File E139594, Canada and USA<br>CE (EN 61131-2 EMC, EN 61010-1 and EN 61010-2-201 Safety)* |

\* See the Declaration of Conformity for details.

| Removable Terminal Block Specifications |   |   |
|---|---|---|
| Part Number                             | P1-10RTB  | P1-10RTB-1  |
| Number of Positions                     | 10 screw terminals  | 10 spring clamp terminals   |
| Wire Range                              | 30–16 AWG (0.051–1.31 mm <sup>2</sup> )<br>Solid/stranded conductor<br>3/64 in. (1.2 mm) insulation max.<br>1/4 in. (6–7 mm) strip length | 28–16 AWG (0.081–1.31 mm <sup>2</sup> )<br>Solid/stranded conductor<br>3/64 in. (1.2 mm) insulation max.<br>19/64 in. (7–8 mm) strip length |
| Conductors                              | USE COPPER CONDUCTORS, 75°C or equivalent.  |   |
| Screw Driver                            | 0.1 inch (2.5 mm) maximum*  |   |
| Screw Size                              | M2  | N/A   |
| Screw Torque                            | 2.5 lb·in (0.28 N·m)  | N/A   |

\* Recommended screw driver: P/N TW-SD-MSL-1.

# P1-16NE3 AC/DC Sinking/Sourcing Input, (continued)

## Wiring Diagrams

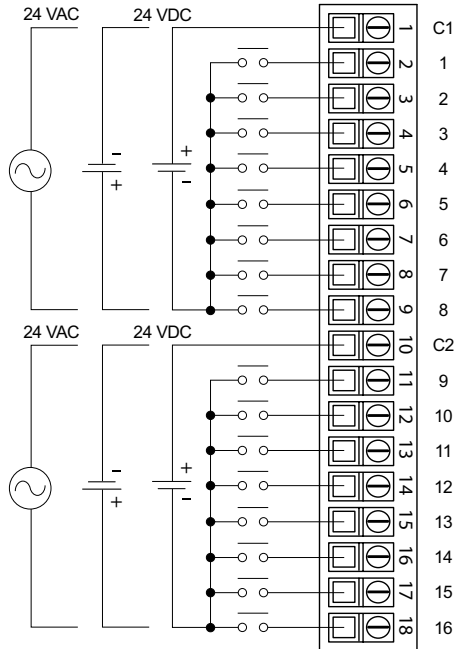

### Equivalent Input Circuit

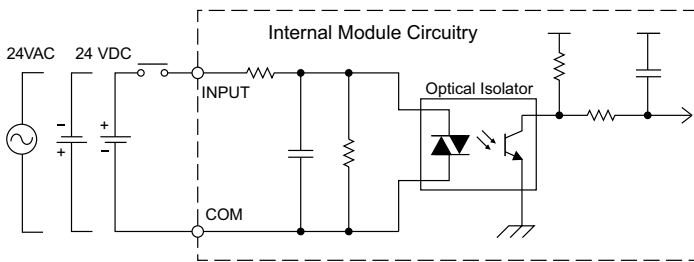

# P1-08NA AC Input

The P1-08NA AC Input Module provides eight 100–240 VAC inputs for use with the Productivity1000 system.

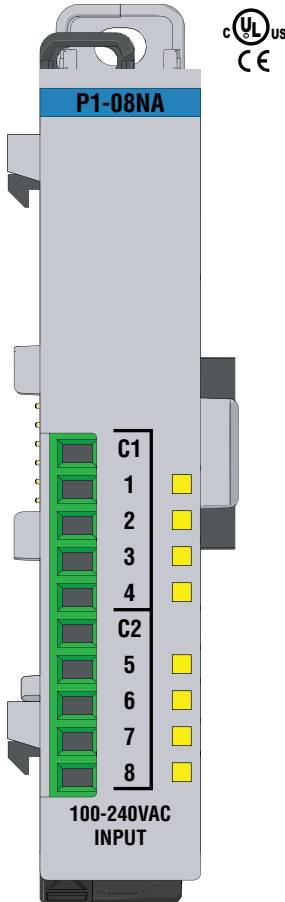

| Input Specifications         |  |
|------------------------------|--|
| Inputs per Module            | 8  |
| Rated Voltage                | 100–240 VAC  |
| Input Voltage Range          | 80–288 VAC   |
| AC Frequency                 | 47–63 Hz   |
| Input Current (Typical)      | 7 mA @ 100 VAC (50Hz)<br>8.5 mA @ 100 VAC (60Hz)<br>14.2 mA @ 240 VAC (50Hz)<br>17 mA @ 240 VAC (60Hz) |
| Maximum Input Current @ Temp | 26 mA @ 60°C (288 VAC)   |
| Input Impedance              | 15 kΩ (50 Hz), 12 kΩ (60 Hz)   |
| ON Voltage Level             | >70 VAC  |
| OFF Voltage Level            | <20 VAC  |
| Minimum ON Current           | 5 mA   |
| Maximum OFF Current          | 2 mA   |
| OFF to ON Response           | <10 ms   |
| ON to OFF Response           | <25 ms   |
| Status Indicators            | Logic Side (8 points)  |
| Commons per Module*          | 2 Isolated (4 points/common) @ 120 VAC<br>2 Non-isolated @ 240 VAC                                     |

\* C1 and C2 must be jumpered together by an external wire during 240 VAC applications.

Terminal blocks sold separately

We recommend using pre-wired ZIPLink cables and connection modules. See Chapter 5. If you wish to hand-wire your module, removable terminal blocks are sold separately. Order part number P1-10RTB or P1-10RTB-1



## P1-08NA AC Input, (continued)

| General Specifications          |  |
|---------------------------------|--|
| Operating Air Temperature       | 0°C– 60°C (32°F–140°F),  |
| Storage Temperature             | -20°C–70°C (-4°F–158°F)  |
| Humidity                        | 5 to 95% (non-condensing)  |
| Environmental Air               | No corrosive gases permitted   |
| Vibration                       | IEC60068-2-6 (Test Fc)   |
| Shock                           | IEC60068-2-27 (Test Ea)  |
| Field to Logic Side Isolation   | 1800 VAC applied for 1 s   |
| Insulation Resistance           | >10 MΩ @ 500 VDC   |
| Heat Dissipation                | 1800 mW  |
| Enclosure Type                  | Open equipment   |
| Module Location                 | Any I/O slot in a Productivity1000 system.   |
| Field Wiring                    | Use <b>ZIP</b> Link wiring system or optional terminal block (not included). See "Wiring Options" in Chapter 5.          |
| Terminal Type (Sold separately) | 10-position removable terminal block   |
| Weight                          | 70 g (2.5 oz)  |
| Agency Approvals                | UL 61010-1 and UL 61010-2-201 File E139594, Canada and USA<br>CE (EN 61131-2 EMC, EN 61010-1 and EN 61010-2-201 Safety)* |

\* See CE Declaration of Conformance for details.

| Removable Terminal Block Specifications |   |   |
|---|---|---|
| Part Number                             | P1-10RTB  | P1-10RTB-1  |
| Number of Positions                     | 10 screw terminals  | 10 spring clamp terminals   |
| Wire Range                              | 30–16 AWG (0.051–1.31 mm <sup>2</sup> )<br>Solid/stranded conductor<br>3/64 in. (1.2 mm) insulation max.<br>1/4 in. (6–7 mm) strip length | 28–16 AWG (0.081–1.31 mm <sup>2</sup> )<br>Solid/stranded conductor<br>3/64 in. (1.2 mm) insulation max.<br>19/64 in. (7–8 mm) strip length |
| Conductors                              | USE COPPER CONDUCTORS, 75°C or equivalent.  |   |
| Screw Driver                            | 0.1 inch (2.5 mm) maximum*  |   |
| Screw Size                              | M2  | N/A   |
| Screw Torque                            | 2.5 lb·in (0.28 N·m)  | N/A   |

\* Recommended screw driver: P/N TW-SD-MSL-1.

# P1-08NA AC Input, (continued)

## Wiring Diagrams

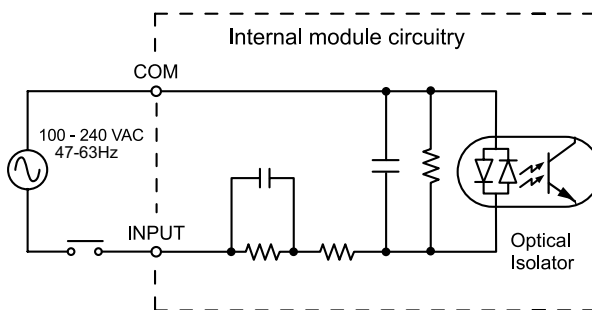
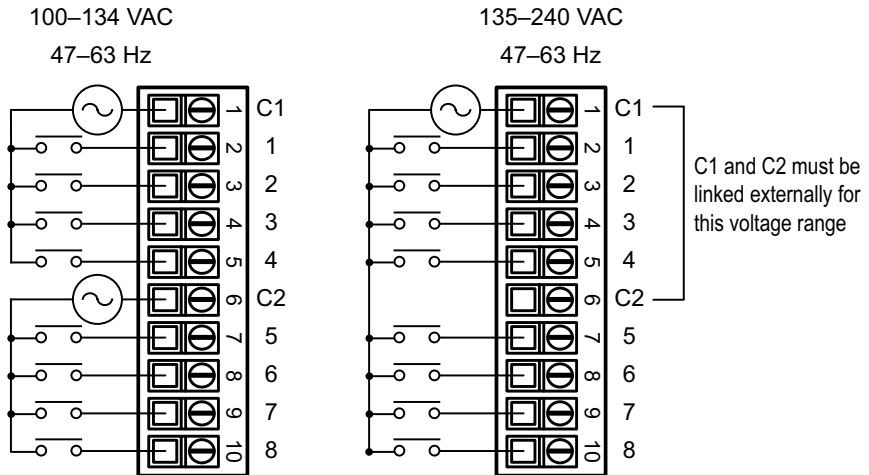

# P1-08TD-TTL DC Output

The P1-08TD-TTL Output Module provides eight sourcing outputs to control TTL level loads for use with the Productivity1000 system.

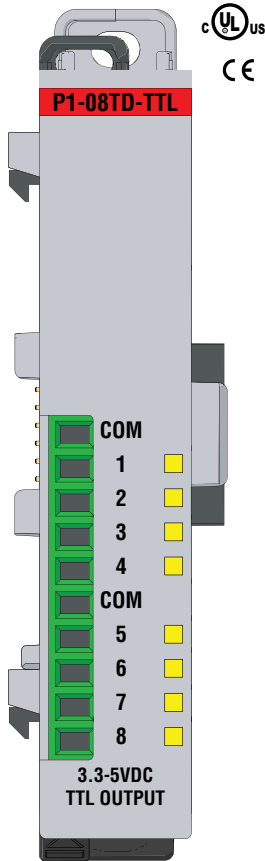

| Output Specifications          |                                 |
|--------------------------------|---------------------------------|
| Outputs per Module             | 8 sourcing                      |
| Output Type                    | TTL Driver                      |
| Rated Voltage                  | 5 V                             |
| Operating Voltage Range        | 5 V $\pm$ 2%                    |
| Minimum Output Current         | 0 $\mu$ A                       |
| Maximum Output Current         | 20 mA per point or 100 mA total |
| On Voltage Drop                | 0.2 V @ max. load               |
| OFF to ON, ON to OFF Response  | $\leq$ 0.5 ms                   |
| Status Indicators              | Logic Side (8 points)           |
| Commons                        | 2, no isolation                 |
| Maximum Applicable Fuse        | None                            |
| External Power Supply Required | None                            |

| Removable Terminal Block Specifications |   |   |
|---|---|---|
| Part Number                             | P1-10RTB  | P1-10RTB-1  |
| Number of Positions                     | 10 screw terminals  | 10 spring clamp terminals   |
| Wire Range                              | 30–16 AWG (0.051–1.31 mm <sup>2</sup> )<br>Solid/stranded conductor<br>3/64 in. (1.2 mm) insulation max.<br>1/4 in. (6–7 mm) strip length | 28–16 AWG (0.081–1.31 mm <sup>2</sup> )<br>Solid/stranded conductor<br>3/64 in. (1.2 mm) insulation max.<br>19/64 in. (7–8 mm) strip length |
| Conductors                              | USE COPPER CONDUCTORS, 75°C or equivalent.  |   |
| Screw Driver                            | 0.1 inch (2.5 mm) maximum*  |   |
| Screw Size                              | M2  | N/A   |
| Screw Torque                            | 2.5 lb-in (0.28 N-m)  | N/A   |

\* Recommended screw driver: P/N TW-SD-MSL-1

Terminal blocks sold separately



**NOTE:** Module shown with flip-up finger-safe terminal cover removed for clarity.

We recommend using pre-wired ZIPLink cables and connection modules. See Chapter 5. If you wish to hand-wire your module, removable terminal blocks are sold separately. Order part number P1-10RTB or P1-10RTB-1



## P1-08TD-TTL DC Output (continued)

| General Specifications           |  |
|----------------------------------|--|
| Operating Air Temperature        | 0°C–60°C (32°F–140°F)  |
| Storage Temperature              | -20°C–70°C (-4°F–158°F)  |
| Humidity                         | 5 to 95% (non-condensing)  |
| Altitude                         | 2,000 meters max.  |
| Pollution Degree                 | 2  |
| Environmental Air                | No corrosive gases permitted   |
| Vibration                        | IEC60068-2-6 (Test Fc)   |
| Shock                            | IEC60068-2-27 (Test Ea)  |
| Overvoltage Category             | II   |
| Field to Logic Side Isolation    | 1750 VDC applied for 5 s   |
| Insulation Resistance            | >10 MΩ @ 500 VDC   |
| Heat Dissipation                 | 1010 mW  |
| Enclosure Type                   | Open equipment   |
| Module Keying to Backplane       | Electronic   |
| Module Location                  | Any I/O position in a Productivity®1000 system   |
| Field Wiring                     | Use ZIPLink wiring system or removable terminal block (sold separately). See "Wiring Options" in Chapter 5.              |
| Connector Type (sold separately) | 10-position removable terminal block   |
| Weight                           | 64 g (2.2 oz)  |
| Agency Approvals                 | UL 61010-1 and UL 61010-2-201 File E139594, Canada and USA<br>CE (EN 61131-2 EMC, EN 61010-1 and EN 61010-2-201 Safety)* |

\* See CE Declaration of Conformity for details.

# P1-08TD-TTL DC Output (continued)

## Wiring Diagrams

Single Power Source

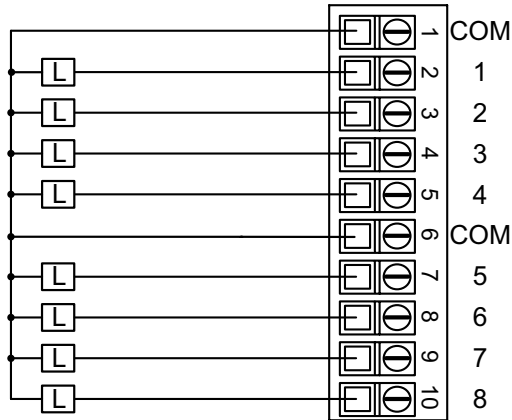

INTERNAL MODULE

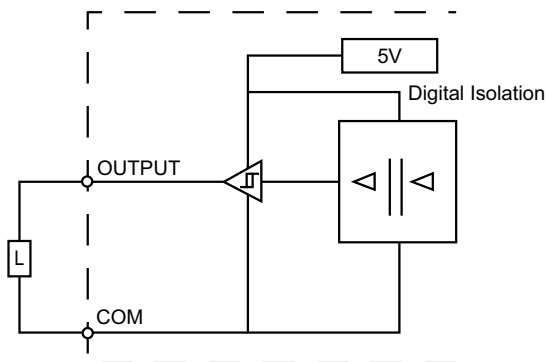

# P1-08TD1 Sinking DC Output

The P1-08TD1 DC Output Module provides eight outputs that sink up to 1A per output from loads powered by 3.3–24 VDC supplies for use with the Productivity1000 system.

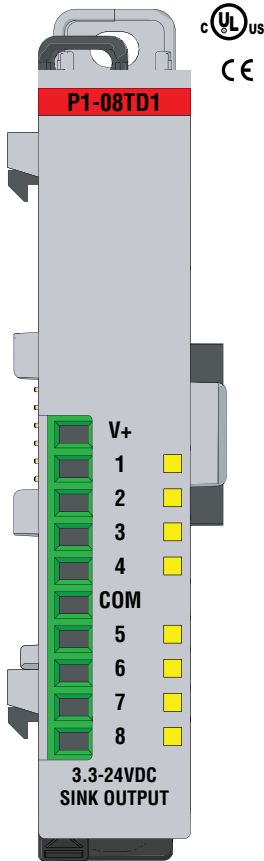

## Output Specifications

|                                     |                              |
|-------------------------------------|------------------------------|
| Outputs per Module                  | 8 sinking                    |
| Output Type                         | N-channel MOSFET, open drain |
| Rated Voltage                       | 3.3–24 VDC                   |
| Operating Voltage Range (Tolerance) | 2.9–26.4 VDC                 |
| Maximum Output Current              | 1 A per point                |
| Minimum Load Current                | 1 mA                         |
| Maximum Leakage Current             | 0.3 mA @ 26.4 VDC            |
| On Voltage Drop                     | 0.2 VDC @ 1 A                |
| Maximum Inrush Current              | 4 A for 50 ms, 6 A for 10ms  |
| OFF to ON, ON to OFF Response       | ≤0.5 ms                      |
| Status Indicators                   | Logic Side (8 pins)          |
| Commons                             | 1 non-isolated               |
| Maximum Applicable Fuse             | 8 A                          |
| External Power Supply Required      | 12–24 VDC (-15%/+20%), 22 mA |

## Removable Terminal Block Specifications

| Part Number         | P1-10RTB  | P1-10RTB-1  |
|---------------------|---|---|
| Number of Positions | 10 screw terminals  | 10 spring clamp terminals   |
| Wire Range          | 30–16 AWG (0.051–1.31 mm <sup>2</sup> )<br>Solid/stranded conductor<br>3/64 in. (1.2 mm) insulation max.<br>1/4 in. (6–7 mm) strip length | 28–16 AWG (0.081–1.31 mm <sup>2</sup> )<br>Solid/stranded conductor<br>3/64 in. (1.2 mm) insulation max.<br>19/64 in. (7–8 mm) strip length |
| Conductors          | USE COPPER CONDUCTORS, 75°C or equivalent.  |   |
| Screw Driver        | 0.1 inch (2.5 mm) maximum*  |   |
| Screw Size          | M2  | N/A   |
| Screw Torque        | 2.5 lb-in (0.28 N-m)  | N/A   |

\* Recommended screw driver: P/N TW-SD-MSL-1

Terminal blocks sold separately



**NOTE:** Module shown with flip-up finger-safe terminal cover removed for clarity.

We recommend using pre-wired ZIPLink cables and connection modules. See Chapter 5. If you wish to hand-wire your module, removable terminal blocks are sold separately. Order part number P1-10RTB or P1-10RTB-1



## P1-08TD1 Sinking DC Output (continued)

| General Specifications           |  |
|----------------------------------|--|
| Operating Air Temperature        | 0°C– 60°C (32°F–140°F)   |
| Storage Temperature              | -20°C–70°C (-4°F–158°F)  |
| Humidity                         | 5 to 95% (non-condensing)  |
| Environmental Air                | No corrosive gases permitted   |
| Vibration                        | IEC60068-2-6 (Test Fc)   |
| Shock                            | IEC60068-2-27 (Test Ea)  |
| Field to Logic Side Isolation    | 1800 VAC applied for 1 s   |
| Insulation Resistance            | >10 MΩ @ 500 VDC   |
| Heat Dissipation                 | 1800 mW  |
| Enclosure Type                   | Open equipment   |
| Module Keying to Backplane       | Electronic   |
| Module Location                  | Any I/O position in a Productivity@1000 system   |
| Field Wiring                     | Use ZIPLink wiring system or removable terminal block (sold separately). See "Wiring Options" in Chapter 5.              |
| Connector Type (sold separately) | 10-position removable terminal block   |
| Weight                           | 60 g (2.1 oz)  |
| Agency Approvals                 | UL 61010-1 and UL 61010-2-201 File E139594, Canada and USA<br>CE (EN 61131-2 EMC, EN 61010-1 and EN 61010-2-201 Safety)* |

\* See CE Declaration of Conformity for details.

# P1-08TD1 Sinking DC Output (continued)

## Wiring Diagrams

Single Power Source

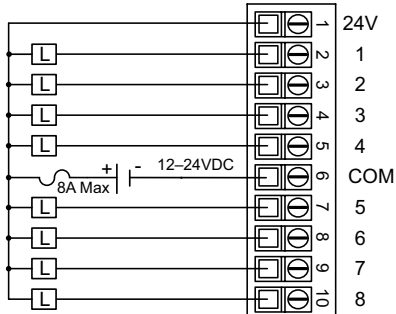

Dual Power Source

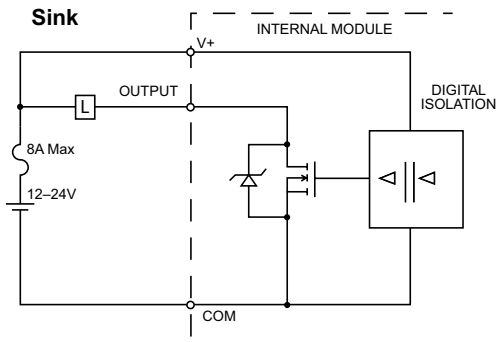
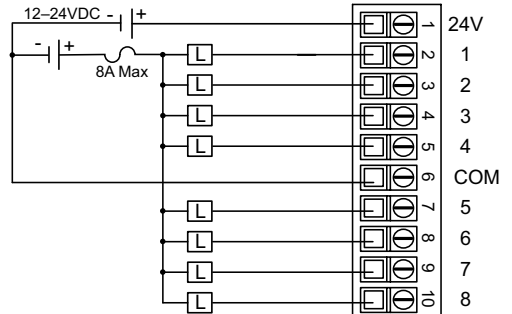

# P1-08TD2 Sourcing DC Output

The P1-08TD2 DC Output Module provides eight non-isolated outputs that source up to 1 A per output from a 12–24 VDC supply for use with the Productivity®1000 system.

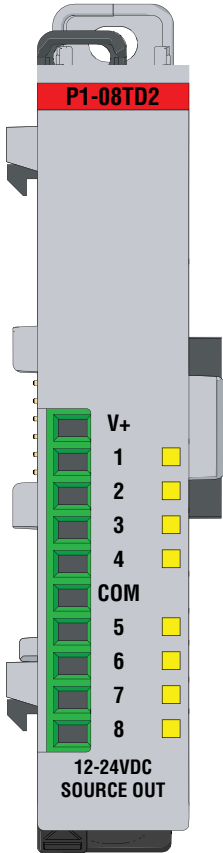

| Output Specifications          |                               |
|--------------------------------|-------------------------------|
| Outputs per Module             | 8 sourcing                    |
| Voltage Rating                 | 12–24 VDC                     |
| Operating Voltage Range        | 10.2–28.8 VDC                 |
| Output Type                    | P-channel MOSFET, open source |
| Maximum Output Current         | 1 A per point                 |
| Minimum Load Current           | 1 mA                          |
| Maximum Leakage Current        | 0.3 mA @ 28.8 VDC             |
| On Voltage Drop                | 0.2 VDC @ 1 A                 |
| Maximum Inrush Current         | 4 A for 50 ms, 6 A for 10 ms  |
| OFF to ON, ON to OFF Response  | 0.5 ms                        |
| Status Indicators              | Logic Side (8 points)         |
| Commons                        | 1 non-isolated                |
| Maximum Applicable Fuses       | 8 A                           |
| External Power Supply Required | 12–24 VDC (-15%/+20%) @ 22mA  |

| Removable Terminal Block Specifications |   |   |
|---|---|---|
| Part Number                             | P1-10RTB  | P1-10RTB-1  |
| Number of Positions                     | 10 screw terminals  | 10 spring clamp terminals   |
| Wire Range                              | 30–16 AWG (0.051–1.31 mm <sup>2</sup> )<br>Solid/stranded conductor<br>3/64 in. (1.2 mm) insulation max.<br>1/4 in. (6–7 mm) strip length | 28–16 AWG (0.081–1.31 mm <sup>2</sup> )<br>Solid/stranded conductor<br>3/64 in. (1.2 mm) insulation max.<br>19/64 in. (7–8 mm) strip length |
| Conductors                              | USE COPPER CONDUCTORS, 75°C or equivalent.  |   |
| Screw Driver                            | 0.1 inch (2.5 mm) maximum*  |   |
| Screw Size                              | M2  | N/A   |
| Screw Torque                            | 2.5 lb-in (0.28 N-m)  | N/A   |

\* Recommended screw driver: P/N TW-SD-MSL-1

Terminal blocks sold separately

We recommend using pre-wired ZIPLink cables and connection modules. See Chapter 5. If you wish to hand-wire your module, removable terminal blocks are sold separately. Order part number P1-10RTB or P1-10RTB-1.



## P1-08TD2 Sourcing DC Output (continued)

| General Specifications           |  |
|----------------------------------|--|
| Operating Air Temperature        | 0°C–60°C (32°F–140°F)  |
| Storage Temperature              | -20°C–70°C (-4°F–158°F)  |
| Humidity                         | 5 to 95% (non-condensing)  |
| Environmental Air                | No corrosive gases permitted   |
| Vibration                        | IEC60068-2-6 (Test Fc)   |
| Shock                            | IEC60068-2-27 (Test Ea)  |
| Field to Logic Side Isolation    | 1800 VAC applied for 1 s   |
| Insulation Resistance            | >10 MΩ @ 500 VDC   |
| Heat Dissipation                 | 2600 mW  |
| Enclosure Type                   | Open equipment   |
| Module Keying to Backplane       | Electronic   |
| Module Location                  | Any I/O position in a Productivity1000 system  |
| Field Wiring                     | Use <b>ZIPLink</b> wiring system or removable terminal block (sold separately). See “Wiring Options” in Chapter 5.       |
| Connector Type (sold separately) | 10-position removable terminal block   |
| Weight                           | 58 g (2.1 oz)  |
| Agency Approvals                 | UL 61010-1 and UL 61010-2-201 File E139594, Canada and USA<br>CE (EN 61131-2 EMC, EN 61010-1 and EN 61010-2-201 Safety)* |

\* See CE Declaration of Conformity for details.

# P1-08TD2 Sourcing Output (continued)

## Wiring Diagrams

Single Power Source

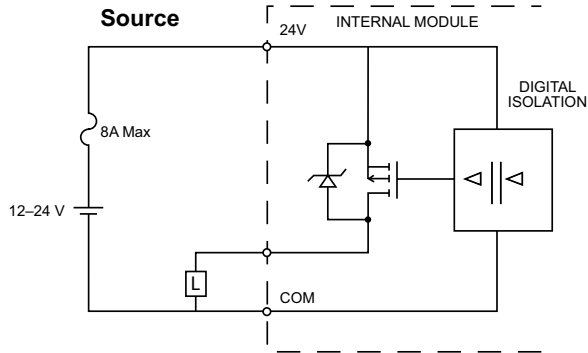
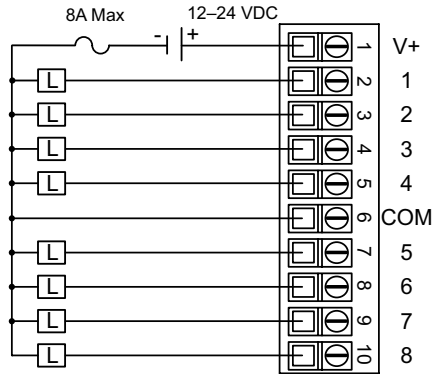

# P1-15TD1 Sinking DC Output

The P1-15TD1 DC Output Module provides fifteen outputs that sink up to 1A per point from loads powered by 3.3–24 VDC for use with the Productivity1000 system.

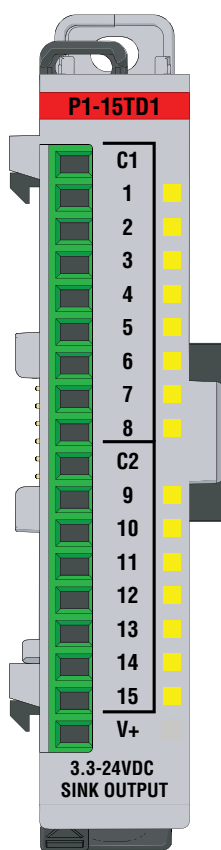

| Output Specifications               |                              |
|-------------------------------------|------------------------------|
| Outputs per Module                  | 15 sinking                   |
| Output Type                         | N-channel MOSFET, open drain |
| Rated Voltage                       | 3.3–24 VDC                   |
| Operating Voltage Range (Tolerance) | 2.9–26.4 VDC                 |
| Maximum Output Current              | 1A per point / 8A per common |
| Minimum Load Current                | 1 mA                         |
| Maximum Leakage Current             | 0.3 mA @ 30 VDC              |
| On Voltage Drop                     | 0.2 VDC @ 1 A                |
| Maximum Inrush Current              | 4 A for 50 ms, 6 A for 10 ms |
| OFF to ON, ON to OFF Response       | ≤0.5 ms                      |
| Status Indicators                   | Logic Side (15 points)       |
| Commons                             | 2 non-isolated               |
| Maximum Applicable Fuse             | 8 A                          |
| External Power Supply Required      | 12–24 VDC (-15%/+20%), 22 mA |

| Removable Terminal Block Specifications |   |   |
|---|---|---|
| Part Number                             | P1-10RTB  | P1-10RTB-1  |
| Number of Positions                     | 10 screw terminals  | 10 spring clamp terminals   |
| Wire Range                              | 30–16 AWG (0.051–1.31 mm <sup>2</sup> )<br>Solid/stranded conductor<br>3/64 in. (1.2 mm) insulation max.<br>1/4 in. (6–7 mm) strip length | 28–16 AWG (0.081–1.31 mm <sup>2</sup> )<br>Solid/stranded conductor<br>3/64 in. (1.2 mm) insulation max.<br>19/64 in. (7–8 mm) strip length |
| Conductors                              | USE COPPER CONDUCTORS, 75°C or equivalent.  |   |
| Screw Driver                            | 0.1 inch (2.5 mm) maximum*  |   |
| Screw Size                              | M2  | N/A   |
| Screw Torque                            | 2.5 lb·in (0.28 N·m)  | N/A   |

\* Recommended screw driver: P/N TW-SD-MSL-1

Terminal blocks sold separately

We recommend using pre-wired ZIPLink cables and connection modules. See Chapter 5. If you wish to hand-wire your module, removable terminal blocks are sold separately. Order part number P2-RTB or P2-RTB-1.



## P1-15TD1 Sinking DC Output (continued)

| General Specifications           |  |
|----------------------------------|--|
| Operating Air Temperature        | 0°C– 60°C (32°F–140°F)   |
| Storage Temperature              | -20°C–70°C (-4°F–158°F)  |
| Humidity                         | 5 to 95% (non-condensing)  |
| Environmental Air                | No corrosive gases permitted   |
| Vibration                        | IEC60068-2-6 (Test Fc)   |
| Shock                            | IEC60068-2-27 (Test Ea)  |
| Field to Logic Side Isolation    | 1800 VAC applied for 1 s   |
| Insulation Resistance            | >10 MΩ @ 500 VDC   |
| Heat Dissipation                 | 1800 mW  |
| Enclosure Type                   | Open equipment   |
| Module Location                  | Any I/O position in a Productivity1000 system  |
| Field Wiring                     | Use <b>ZIPL</b> ink wiring system or removable terminal block (sold separately). See “Wiring Options” in Chapter 5.      |
| Connector Type (sold separately) | 18-position removable terminal block   |
| Weight                           | 71 g (2.5 oz)  |
| Agency Approvals                 | UL 61010-1 and UL 61010-2-201 File E139594, Canada and USA<br>CE (EN 61131-2 EMC, EN 61010-1 and EN 61010-2-201 Safety)* |

\* See CE Declaration of Conformance for details.

# P1-15TD1 Sinking Output (continued)

## Wiring Diagrams

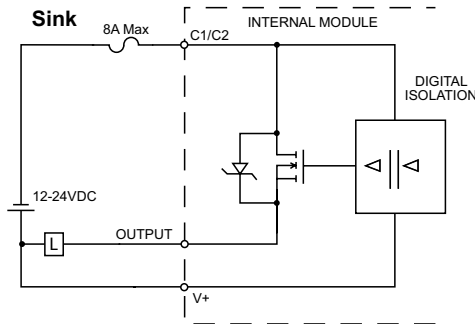
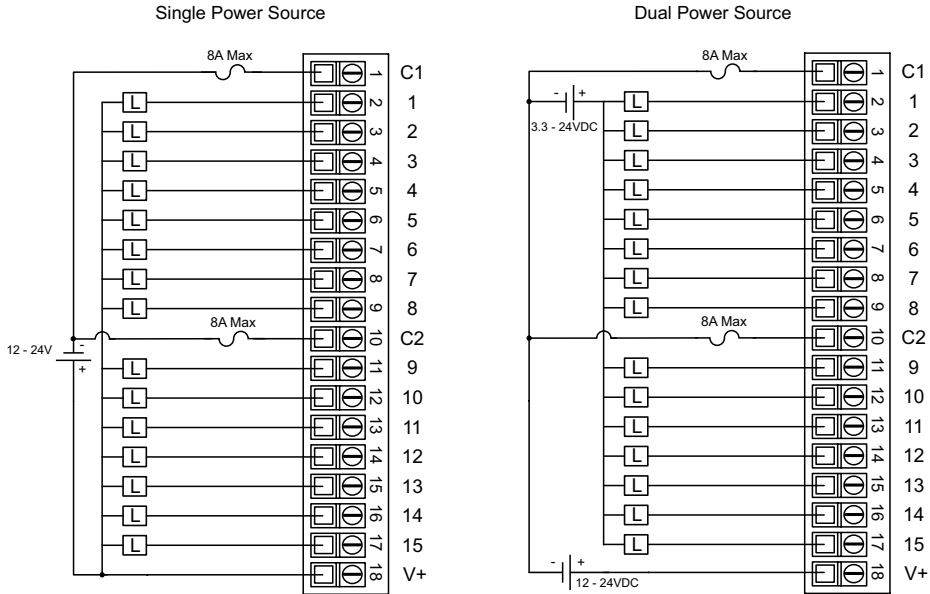

# P1-15TD2 Sourcing DC Output

The P1-15TD2 DC Output Module provides fifteen 12–24 VDC outputs that source up to 1A per point to loads connected to ground by for use with the Productivity1000 system.

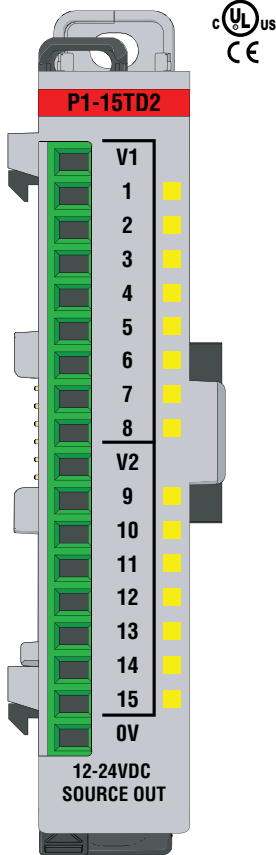

| Output Specifications          |                               |
|--------------------------------|-------------------------------|
| Outputs per Module             | 15 sourcing                   |
| Voltage Rating                 | 12–24 VDC                     |
| Operating Voltage Range        | 10.2–26.4 VDC, Max 30VDC      |
| Output Type                    | P-channel MOSFET, open source |
| Maximum Output Current         | 1A per point/8A per common    |
| Minimum Load Current           | 1mA                           |
| Maximum Leakage Current        | 0.3 mA @ 26.4 VDC             |
| On Voltage Drop                | 0.2 VDC @ 1 A                 |
| Maximum Inrush Current         | 4 A for 50 ms, 6 A for 10 ms  |
| OFF to ON, ON to OFF Response  | 0.5 ms                        |
| Status Indicators              | Logic Side (15 points)        |
| Commons                        | 1 non-isolated                |
| Maximum Applicable Fuses       | 8 A                           |
| External Power Supply Required | 12–24 VDC (-15%/+20%) @ 22 mA |

| Removable Terminal Block Specifications |   |   |
|---|---|---|
| Part Number                             | P1-10RTB  | P1-10RTB-1  |
| Number of Positions                     | 10 screw terminals  | 10 spring clamp terminals   |
| Wire Range                              | 30–16 AWG (0.051–1.31 mm <sup>2</sup> )<br>Solid/stranded conductor<br>3/64 in. (1.2 mm) insulation max.<br>1/4 in. (6–7 mm) strip length | 28–16 AWG (0.081–1.31 mm <sup>2</sup> )<br>Solid/stranded conductor<br>3/64 in. (1.2 mm) insulation max.<br>19/64 in. (7–8 mm) strip length |
| Conductors                              | USE COPPER CONDUCTORS, 75°C or equivalent.  |   |
| Screw Driver                            | 0.1 inch (2.5 mm) maximum*  |   |
| Screw Size                              | M2  | N/A   |
| Screw Torque                            | 2.5 lb-in (0.28 N-m)  | N/A   |

\* Recommended screw driver: P/N TW-SD-MSL-1

Terminal blocks sold separately

We recommend using pre-wired ZIPLink cables and connection modules. See Chapter 5. If you wish to hand-wire your module, removable terminal blocks are sold separately. Order part number P2-RTB or P2-RTB-1.



## P1-15TD2 Sourcing DC Output (continued)

| General Specifications           |  |
|----------------------------------|--|
| Operating Air Temperature        | 0°C– 60°C (32°F–140°F)   |
| Storage Temperature              | -20°C–70°C (-4°F–158°F)  |
| Humidity                         | 5 to 95% (non-condensing)  |
| Environmental Air                | No corrosive gases permitted   |
| Vibration                        | IEC60068-2-6 (Test Fc)   |
| Shock                            | IEC60068-2-27 (Test Ea)  |
| Overvoltage Category             | II   |
| Field to Logic Side Isolation    | 1800 VAC applied for 1 s   |
| Insulation Resistance            | >10 MΩ @ 500 VDC   |
| Heat Dissipation                 | 4000 mW  |
| Enclosure Type                   | Open equipment   |
| Module Location                  | Any I/O position in a Productivity1000 system  |
| Field Wiring                     | Use ZIPLink wiring system or removable terminal block (sold separately). See "Wiring Options" in Chapter 5.              |
| Connector Type (sold separately) | 18-position removable terminal block   |
| Weight                           | 71 g (2.5 oz)  |
| Agency Approvals                 | UL 61010-1 and UL 61010-2-201 File E139594, Canada and USA<br>CE (EN 61131-2 EMC, EN 61010-1 and EN 61010-2-201 Safety)* |

\* See CE Declaration of Conformance for details.

# P1-15TD2 Sourcing Output (continued)

## Wiring Diagrams

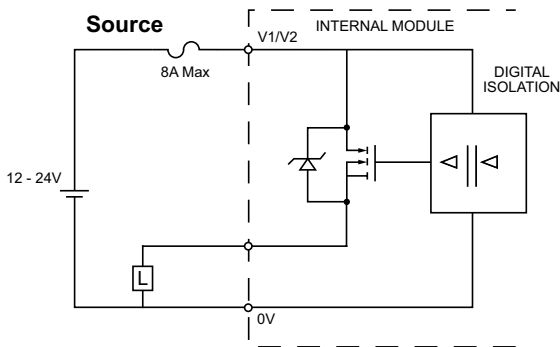
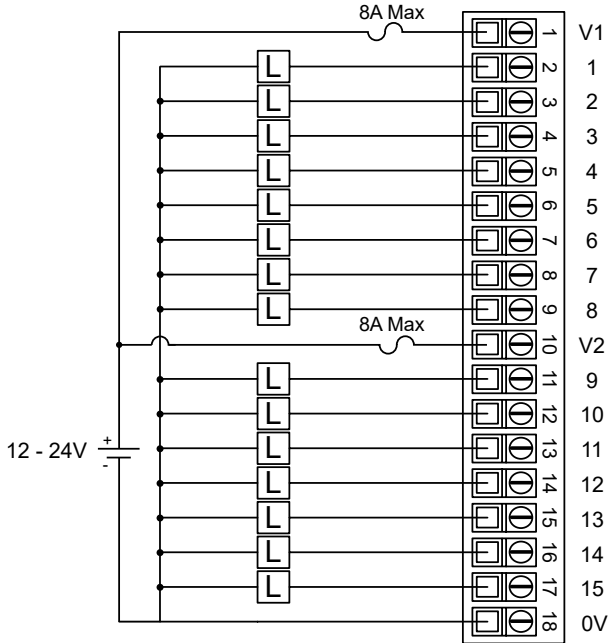

## P1-08TA AC Output

The P1-08TA AC Output Module provides eight 100–240 VAC outputs for use with the Productivity1000 system.

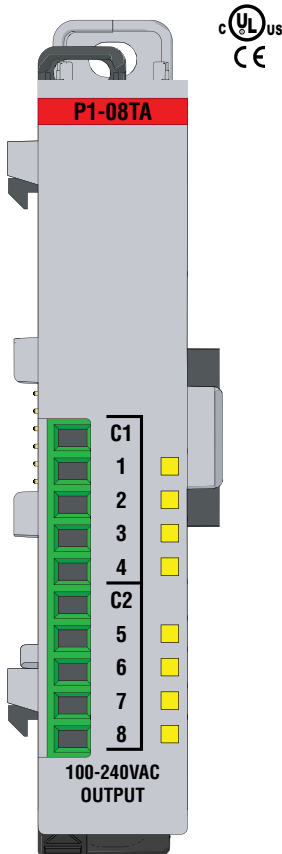

| Output Specifications         |   |
|-------------------------------|---|
| Outputs per Module            | 8   |
| Rated Voltage                 | 100–240 VAC   |
| Operating Voltage Range       | 80–288 VAC  |
| AC Frequency                  | 47–63 Hz  |
| Maximum Output Current        | 0.5 A / point, 4 A /common @ 55°C<br>0.3 A / point, 2.4 A / common @ 60°C |
| Minimum Load Current          | 10 mA   |
| Maximum Leakage Current       | 4 mA @ 264 VAC  |
| On Voltage Drop               | 1.5 VAC @ >50 mA<br>4.0 VAC @ <50 mA                                      |
| Maximum Inrush Current        | 6 A for 10 ms   |
| OFF to ON, ON to OFF Response | 1 ms + 1/2 cycle  |
| Status Indicators             | Logic Side (8 points)   |
| Commons per Module            | 2 Isolated (4 point / common) @ 120 VAC<br>2 Non-isolated @ 240 VAC       |
| Maximum Applicable Fuse       | 8 A   |

\* C1 and C2 must be jumpered together by an external wire during 240 VAC applications.

Terminal blocks sold separately

We recommend using pre-wired ZIPLink cables and connection modules. See Chapter 5. If you wish to hand-wire your module, removable terminal blocks are sold separately. Order part number P1-10RTB or P1-10RTB-1



## P1-08TA AC Output, (continued)

| General Specifications           |  |
|----------------------------------|--|
| Operating Air Temperature        | 0°C–60°C (32°F–140°F),   |
| Storage Temperature              | -20°C–70°C (-4°F–158°F)  |
| Humidity                         | 5 to 95% (non-condensing)  |
| Environmental Air                | No corrosive gases permitted   |
| Vibration                        | IEC60068-2-6 (Test Fc)   |
| Shock                            | IEC60068-2-27 (Test Ea)  |
| Field to Logic Side Isolation    | 1800 VAC applied for 1 s   |
| Insulation Resistance            | >10 MΩ @ 500 VDC   |
| Heat Dissipation                 | 1400 mW  |
| Enclosure Type                   | Open equipment   |
| Module Location                  | Any I/O slot in a Productivity1000 system.   |
| Field Wiring                     | Use ZIPLink wiring system or optional terminal block (not included). See "Wiring Options" in Chapter 5.                  |
| Connector Type (Sold separately) | 10-position removable terminal block   |
| Weight                           | 71 g (2.5 oz)  |
| Agency Approvals                 | UL 61010-1 and UL 61010-2-201 File E139594, Canada and USA<br>CE (EN 61131-2 EMC, EN 61010-1 and EN 61010-2-201 Safety)* |

\* See CE Declaration of Conformance for details.

| Removable Terminal Block Specifications |   |   |
|---|---|---|
| Part Number                             | P1-10RTB  | P1-10RTB-1  |
| Number of Positions                     | 10 screw terminals  | 10 spring clamp terminals   |
| Wire Range                              | 30–16 AWG (0.051–1.31 mm <sup>2</sup> )<br>Solid/stranded conductor<br>3/64 in. (1.2 mm) insulation max.<br>1/4 in. (6–7 mm) strip length | 28–16 AWG (0.081–1.31 mm <sup>2</sup> )<br>Solid/stranded conductor<br>3/64 in. (1.2 mm) insulation max.<br>19/64 in. (7–8 mm) strip length |
| Conductors                              | USE COPPER CONDUCTORS, 75°C or equivalent.  |   |
| Screw Driver                            | 0.1 inch (2.5 mm) maximum*  |   |
| Screw Size                              | M2  | N/A   |
| Screw Torque                            | 2.5 lb-in (0.28 N-m)  | N/A   |

\* Recommended screw driver: P/N TW-SD-MSL-1.

# P1-08TA AC Output, (continued)

## Wiring Diagrams

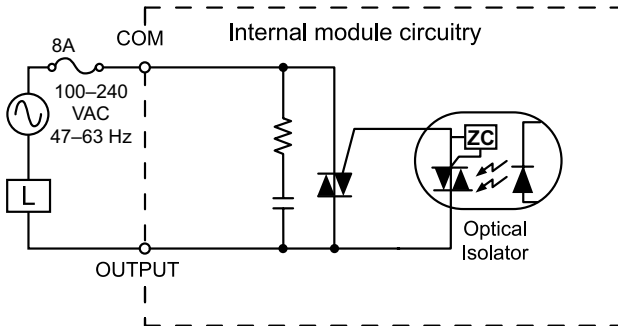
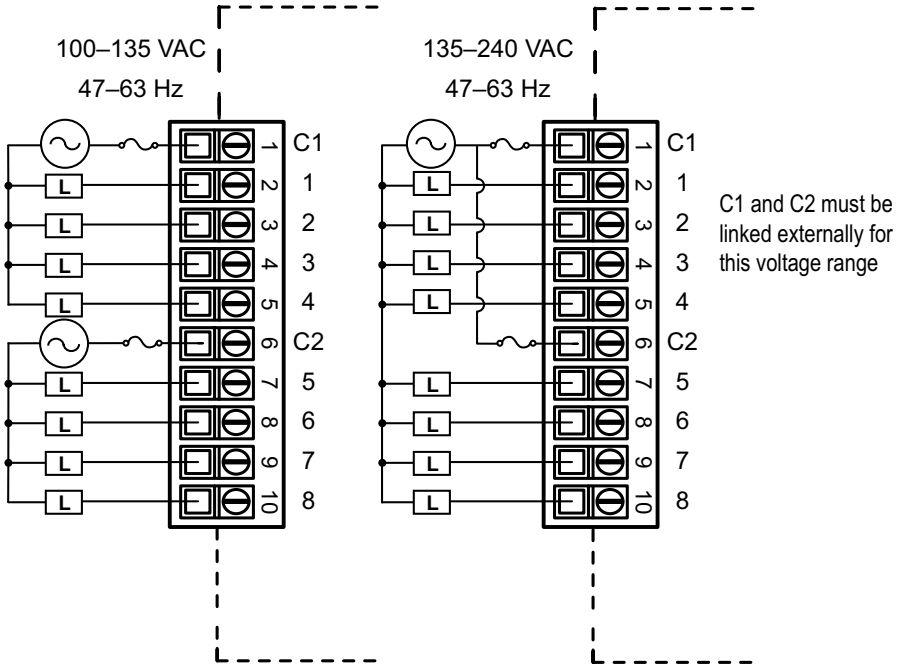

# P1-04TEPS Isolated Relay (SSR) Output

The P1-04TEPS Isolated Relay (SSR) Output Module provides four 24VAC/VDC fault protected, isolated outputs for use with the Productivity1000 system.

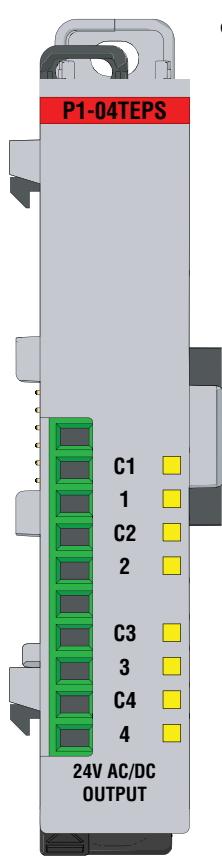

| Output Specifications         |   |
|-------------------------------|---|
| Outputs per Module            | 4   |
| Rated Voltage                 | 24 VAC / 24 VDC   |
| Operating Voltage Range       | 21.6–26.4 VAC/VDC   |
| AC Frequency                  | 47–63 Hz  |
| Output Type                   | SSR   |
| Maximum Output Current @ Temp | 1A @ 50 °C, 0.75 A @ 60 °C  |
| Minimum Load Current          | 10 mA   |
| Maximum Leakage Current       | 1 µA  |
| On Voltage Drop               | 0.35 V  |
| Maximum Inrush Current        | 1.56 A  |
| OFF to ON Response            | 2.5 ms  |
| ON to OFF Response            | 0.5 ms  |
| Status Indicators             | Logic Side (4 points)   |
| Commons per Module            | 4 Isolated (1 point / common)   |
| Protection Circuit            | Not built into module - install external elements such as a fuse (Max. 1.6 A) |
| Fault Protection              | Current Limited > 1.56 A, Thermal Shutdown                                    |

| Channel Status                        |                      |   |
|---------------------------------------|----------------------|---|
| Fault Condition                       | Output Status        | Operation to Reset Fault                  |
| Overload Current or Over Temperature* | Output On, No Output | Remove Short Circuit, Reduce Load Current |

\* Output will auto recover once the fault condition is removed.

Terminal blocks sold separately

We recommend using pre-wired ZIPLink cables and connection modules. See Chapter 5. If you wish to hand-wire your module, removable terminal blocks are sold separately. Order part number P1-10RTB or P1-10RTB-1



## P1-04TEPS Isolated Relay (SSR) Output, (continued)

| General Specifications           |  |
|----------------------------------|--|
| Operating Air Temperature        | 0 to 60 °C (32 to 140 °F),   |
| Storage Temperature              | -20 to +70 °C (-4 to +158 °F)  |
| Humidity                         | 5 to 95% (non-condensing)  |
| Altitude                         | 2,000 meters max   |
| Pollution Degree                 | 2  |
| Environmental Air                | No corrosive gases permitted   |
| Vibration                        | IEC60068-2-6 (Test Fc)   |
| Shock                            | IEC60068-2-27 (Test Ea)  |
| Overvoltage Category             | II   |
| Field to Logic Side Isolation    | 1750 VAC applied for 5 seconds,<br>420 VDC applied for 1 minute  |
| Insulation Resistance            | >10 MΩ @ 500 VDC   |
| Heat Dissipation                 | 1500 mW  |
| Enclosure Type                   | Open equipment   |
| Module Location                  | Any I/O position in a Productivity1000 system.   |
| Field Wiring                     | Use ZIPLink wiring system or optional terminal block (sold separately). See "Wiring Options" in Chapter 5.                     |
| Connector Type (Sold separately) | 10-position removable terminal block   |
| Weight                           | 56 g (1.98 oz)   |
| Agency Approvals                 | UL 61010-1 and UL 61010-2-201 File E139594,<br>Canada and USA<br>CE (EN 61131-2 EMC, EN 61010-1 and<br>EN 61010-2-201 Safety)* |

\* See CE Declaration of Conformance for details.

| Removable Terminal Block Specifications |   |  |
|---|---|--|
| Part Number                             | P1-10RTB  | P1-10RTB-1   |
| Number of Positions                     | 10 screw terminals  | 10 spring clamp terminals  |
| Wire Range                              | 30–16 AWG (0.051–1.31 mm <sup>2</sup> )<br>Solid/stranded conductor<br>3/64 in. (1.2 mm) insulation max.<br>1/4 in. (6–7 mm) strip length | 28–16 AWG (0.081–1.31mm <sup>2</sup> )<br>Solid/stranded conductor<br>3/64 in. (1.2 mm) insulation max.<br>19/64 in. (7–8 mm) strip length |
| Conductors                              | USE COPPER CONDUCTORS, 75°C or equivalent.  |  |
| Screw Driver                            | 0.1 inch (2.5 mm) maximum*  |  |
| Screw Size                              | M2  | N/A  |
| Screw Torque                            | 2.5 lb-in (0.28 N·m)  | N/A  |

\* Recommended screw driver: P/N TW-SD-MSL-1.

# P1-04TEPS Isolated Relay (SSR) Output, (continued)

## Wiring Diagrams

24 VAC/VDC  
50 - 60 Hz

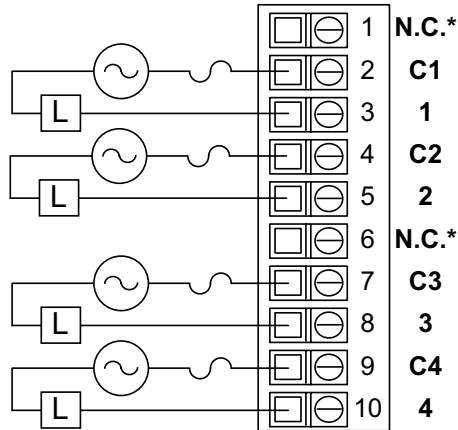

\*N.C. = No Connection

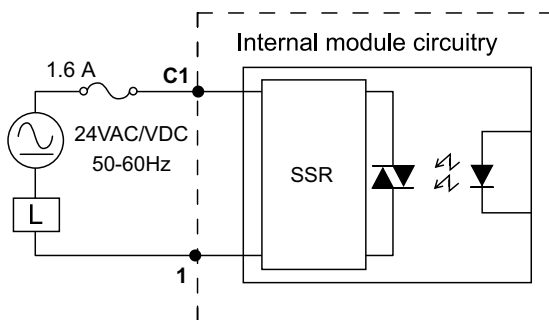

# P1-04TRS Isolated Relay

The P1-04TRS high-current isolated relay output module provides four, 7A surge protected outputs. The P1-04TRS offers both normally open and normally closed relay contacts for use with the Productivity®1000 system.

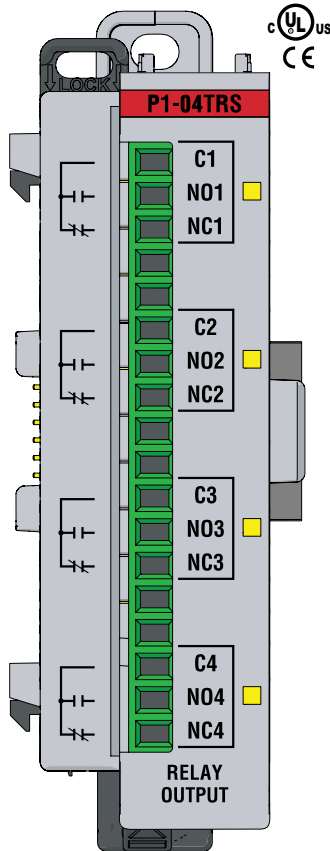

Removable terminal blocks are sold separately. Order part number P2-RTB or P2-RTB-1.

| Output Specifications   |  |
|-------------------------|--|
| Outputs per Module      | 4  |
| Rated Voltage           | 30 VDC<br>100–240 VAC  |
| Operating Voltage Range | 5–30 VDC<br>5–264 VAC  |
| Output type             | 4 Relays, FORM C (SPDT)  |
| AC Frequency            | 47–63 Hz   |
| Maximum Output Current  | 7 A @ 50°C<br>6 A @ 60°C   |
| Minimum Load Current    | 5 mA @ 5 VDC   |
| Maximum Inrush Current  | 7 A for 10 ms  |
| OFF to ON Response      | <10 ms   |
| ON to OFF Response      | <10 ms   |
| Status Indicators       | Logic Side (4 points)  |
| Commons                 | 4 Isolated (1 point / common)  |
| Protection Circuit      | 10 A Max.<br>Not built into module - Install protection elements such as an external fuse. |

| Removable Terminal Block Specifications |   |   |
|---|---|---|
| Part Number                             | P2-RTB  | P2-RTB-1  |
| Number of Positions                     | 18 screw terminals  | 18 spring clamp terminals   |
| Wire Range                              | 30–16 AWG (0.051–1.31 mm <sup>2</sup> )<br>Solid/stranded conductor<br>3/64 in. (1.2 mm) insulation max.<br>1/4 in. (6–7 mm) strip length | 28–16 AWG (0.081–1.31 mm <sup>2</sup> )<br>Solid/stranded conductor<br>3/64 in. (1.2 mm) insulation max.<br>19/64 in. (7–8 mm) strip length |
| Conductors                              | USE COPPER CONDUCTORS, 75°C or equivalent.  |   |
| Screw Driver                            | 0.1 inch (2.5 mm) maximum*  |   |
| Screw Size                              | M2  | N/A   |
| Screw Torque                            | 2.5 lb-in (0.28 N-m)  | N/A   |

\* Recommended screw driver: P/N TW-SD-MSL-1



**NOTE:** The most recent Productivity Suite software and firmware versions may be required to support new modules and new features.

## P1-04TRS Isolated Relay (continued)

| General Specifications           |  |
|----------------------------------|--|
| Operating Air Temperature        | 0°C to 60°C (32°F to 140°F),   |
| Storage Temperature              | -20°C to 70°C (-4°F to 158°F)  |
| Humidity                         | 5 to 95% (non-condensing)  |
| Altitude                         | 2,000 meters max.  |
| Pollution Degree                 | 2  |
| Environmental Air                | No corrosive gases permitted   |
| Vibration                        | IEC60068-2-6 (Test Fc)   |
| Shock                            | IEC60068-2-27 (Test Ea)  |
| Field to Logic Side Isolation    | 3000 VAC applied for 5 seconds<br>1100 VAC applied for 1 minute  |
| Insulation Resistance            | >10 MΩ @ 500 VDC   |
| Heat Dissipation                 | 3800 mW  |
| Overvoltage Category             | II   |
| Enclosure Type                   | Open equipment   |
| Module Keying                    | Electronic   |
| Module Location                  | Any I/O position in a Productivity1000 system  |
| Field Wiring                     | Use removable terminal block (sold separately). See "Wiring Options" in Chapter 5.   |
| Connector Type (sold separately) | 18-position removable terminal block   |
| Weight                           | 120 g (4.23 oz)  |
| Agency Approvals                 | UL 61010-1 and UL 61010-2-201 File E139594,<br>Canada and USA<br>CE (EN 61131-2 EMC, EN 61010-1 and<br>EN 61010-2-201 Safety)* |

\* See CE Declaration of Conformity for details.

| Typical Relay Life     |                                |
|------------------------|--------------------------------|
| Voltage & Type of Load | Operations at 6 A Load Current |
| 30 VDC Resistive       | 100,000                        |
| 30 VDC Solenoid        | 100,000                        |
| 120 VAC Resistive      | 100,000                        |
| 120 VAC Solenoid       | 100,000                        |
| 240 VAC Resistive      | 100,000                        |
| 240 VAC Solenoid       | 100,000                        |

# P1-04TRS Isolated Relay (continued)

## Wiring Diagrams

5–30 VDC  
 5–264 VAC  
 47–63 Hz

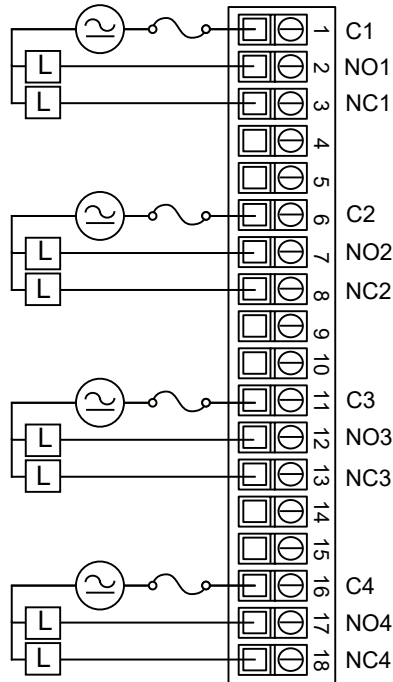

### Equivalent Output Circuit

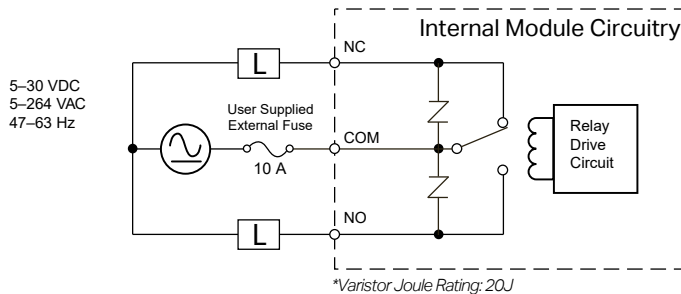

# P1-08TRS Isolated Relay

The P1-08TRS high-current isolated relay output module provides eight, 3A surge protected outputs. The P1-08TRS offers both normally open and normally closed relay contacts for use with the Productivity®1000 system.

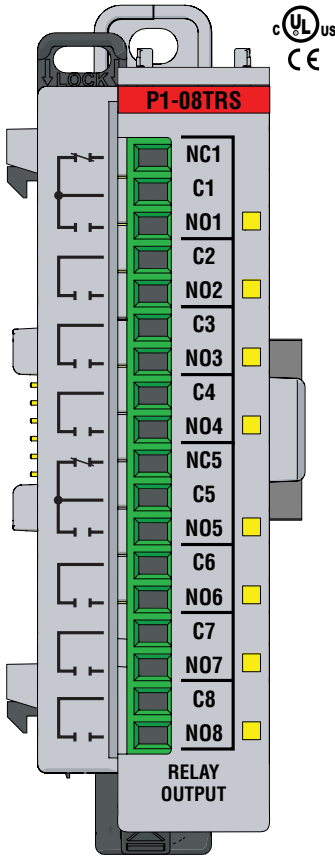

Terminal blocks sold separately

## Output Specifications

|                         |  |
|-------------------------|--|
| Outputs per Module      | 8  |
| Rated Voltage           | 6.25–30 VDC<br>6–120 VAC   |
| Operating Voltage Range | 5.1–28.8 VDC<br>5.1–132 VAC  |
| Output type             | 6 Relays, FORM A (SPST)<br>2 Relays, FORM C (SPDT)                                     |
| AC Frequency            | 47–63 Hz   |
| Maximum Output Current  | 3 A / point @ 60°C for both AC and DC<br>2 A / point if used with <b>ZIPLink</b> Cable |
| Minimum Load Current    | 5 mA @ 5VDC  |
| Maximum Inrush Current  | 3 A for 10ms   |
| OFF to ON Response      | <10 ms   |
| ON to OFF Response      | <10 ms   |
| Status Indicators       | Logic Side (8 points)  |
| Commons                 | 8 Isolated (1 point / common)  |
| Maximum Applicable Fuse | 8 A Max  |

## Removable Terminal Block Specifications

| Part Number         | P1-10RTB  | P1-10RTB-1  |
|---------------------|---|---|
| Number of Positions | 10 screw terminals  | 10 spring clamp terminals   |
| Wire Range          | 30–16 AWG (0.051–1.31 mm <sup>2</sup> )<br>Solid/stranded conductor<br>3/64 in. (1.2 mm) insulation max.<br>1/4 in. (6–7 mm) strip length | 28–16 AWG (0.081–1.31 mm <sup>2</sup> )<br>Solid/stranded conductor<br>3/64 in. (1.2 mm) insulation max.<br>19/64 in. (7–8 mm) strip length |
| Conductors          | USE COPPER CONDUCTORS, 75°C or equivalent.  |   |
| Screw Driver        | 0.1 inch (2.5 mm) maximum*  |   |
| Screw Size          | M2  | N/A   |
| Screw Torque        | 2.5 lb-in (0.28 N·m)  | N/A   |

\* Recommended screw driver: P/N TW-SD-MSL-1

We recommend using pre-wired ZIPLink cables and connection modules. See Chapter 5.

If you wish to hand-wire your module, removable terminal blocks are sold separately. Order part number P2-RTB or P2-RTB-1.



## P1-08TRS Isolated Relay (continued)

| General Specifications           |  |
|----------------------------------|--|
| Operating Air Temperature        | 0°C– 60°C (32°F–140°F),  |
| Storage Temperature              | -20°C–70°C (-4°F–158°F)  |
| Humidity                         | 5 to 95% (non-condensing)  |
| Environmental Air                | No corrosive gases permitted   |
| Vibration                        | IEC60068-2-6 (Test Fc)   |
| Shock                            | IEC60068-2-27 (Test Ea)  |
| Field to Logic Side Isolation    | 1800 VAC applied for 1 s   |
| Insulation Resistance            | >10 MΩ @ 500 VDC   |
| Heat Dissipation                 | 3000 mW  |
| Enclosure Type                   | Open equipment   |
| Module Keying                    | Electronic   |
| Module Location                  | Any I/O position in a Productivity1000 system  |
| Field Wiring                     | Use ZIPLink wiring system or removable terminal block (sold separately). See “Wiring Options” in Chapter 5.              |
| Connector Type (sold separately) | 18-position removable terminal block   |
| Weight                           | 112 g (4 oz)   |
| Agency Approvals                 | UL 61010-1 and UL 61010-2-201 File E139594, Canada and USA<br>CE (EN 61131-2 EMC, EN 61010-1 and EN 61010-2-201 Safety)* |

\* See CE Declaration of Conformity for details.

| Typical Relay Life     |                                |
|------------------------|--------------------------------|
| Voltage & Type of Load | Operations at 4 A Load Current |
| 30 VDC Resistive       | 100,000                        |
| 30 VDC Solenoid        | 100,000                        |
| 120 AC Resistive       | 100,000                        |
| 120 VAC Solenoid       | 100,000                        |

# P1-08TRS Isolated Relay (continued)

## Wiring Diagrams

6–27 VDC  
6–120 VAC  
50–60 Hz

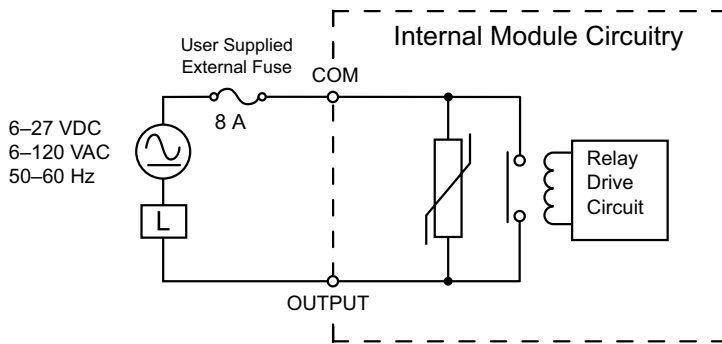
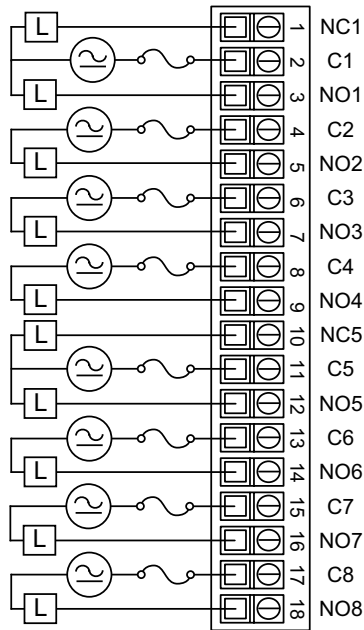

# P1-16TR Relay Output

The P1-16TR Relay Output Module provides sixteen 2 A outputs with two isolated commons for use with the Productivity@1000 system.

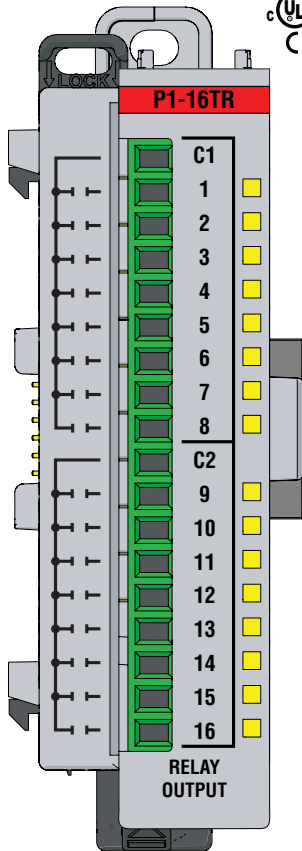

| Output Specifications         |   |
|-------------------------------|---|
| Outputs Channels              | 16  |
| Rated Voltage                 | 6.25–30 VDC, 6–120 VAC  |
| Operating Voltage Range       | 5–30 VDC, 5–144 VAC   |
| Output Type                   | Relay, FORM A (SPST)  |
| AC Frequency                  | 47–63 Hz  |
| Maximum Output Current        | 2 A / point, 8 A / common for both AC and DC<br>2 A / point, 4 A / common if used with <b>ZIPLink</b> Cable |
| Minimum Load Current          | 5 mA @ 5 VDC  |
| Maximum Inrush Current        | 5 A for 10 ms   |
| OFF to ON, ON to OFF Response | ≤10 ms  |
| Status Indicators             | Logic Side (16 points)  |
| Commons                       | 2 Isolated (8 point / common)   |
| Maximum Applicable Fuse       | 8 A   |

| Removable Terminal Block Specifications |   |   |
|---|---|---|
| Part Number                             | P1-10RTB  | P1-10RTB-1  |
| Number of Positions                     | 10 screw terminals  | 10 spring clamp terminals   |
| Wire Range                              | 30–16 AWG (0.051–1.31 mm <sup>2</sup> )<br>Solid/stranded conductor<br>3/64 in. (1.2 mm) insulation max.<br>1/4 in. (6–7 mm) strip length | 28–16 AWG (0.081–1.31 mm <sup>2</sup> )<br>Solid/stranded conductor<br>3/64 in. (1.2 mm) insulation max.<br>19/64 in. (7–8 mm) strip length |
| Conductors                              | USE COPPER CONDUCTORS, 75°C or equivalent.  |   |
| Screw Driver                            | 0.1 inch (2.5 mm) maximum*  |   |
| Screw Size                              | M2  | N/A   |
| Screw Torque                            | 2.5 lb-in (0.28 N-m)  | N/A   |

\* Recommended screw driver: P/N TW-SD-MSL-1

Terminal blocks sold separately

We recommend using pre-wired **ZIPLink** cables and connection modules. See Chapter 5. If you wish to hand-wire your module, removable terminal blocks are sold separately. Order part number P2-RTB or P2-RTB-1.



## P1-16TR Relay Output (continued)

| General Specifications           |  |
|----------------------------------|--|
| Operating Air Temperature        | 0°C– 60°C (32°F–140°F)   |
| Storage Temperature              | -20°C–70°C (-4°F–158°F)  |
| Humidity                         | 5 to 95% (non-condensing)  |
| Environmental Air                | No corrosive gases permitted   |
| Vibration                        | IEC60068-2-6 (Test Fc)   |
| Shock                            | IEC60068-2-27 (Test Ea)  |
| Field to Logic Side Isolation    | 1800 VAC applied for 1 s   |
| Insulation Resistance            | >10 MΩ @ 500 VDC   |
| Heat Dissipation                 | 3000 mW  |
| Enclosure Type                   | Open equipment   |
| Module Location                  | Any I/O position in a Productivity1000 system.   |
| Field Wiring                     | Use <b>ZIPLink</b> wiring system or removable terminal block (sold separately). See "Wiring Options" in Chapter 5.       |
| Connector Type (sold separately) | 18-position removable terminal block   |
| Weight                           | 91 g (3.2 oz)  |
| Agency Approvals                 | UL 61010-1 and UL 61010-2-201 File E139594, Canada and USA<br>CE (EN 61131-2 EMC, EN 61010-1 and EN 61010-2-201 Safety)* |

\* See CE Declaration of Conformity for details.

| Typical Relay Life     |                                |
|------------------------|--------------------------------|
| Voltage & Type of Load | Operations at 1 A Load Current |
| 30 VDC Resistive       | 100,000                        |
| 30 VDC Solenoid        | 100,000                        |
| 120 VAC Resistive      | 100,000                        |
| 120 VAC Solenoid       | 100,000                        |

# P1-16TR Relay Output (continued)

## Wiring Diagrams

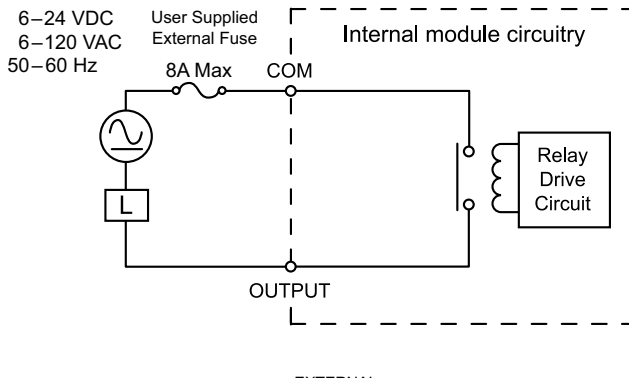
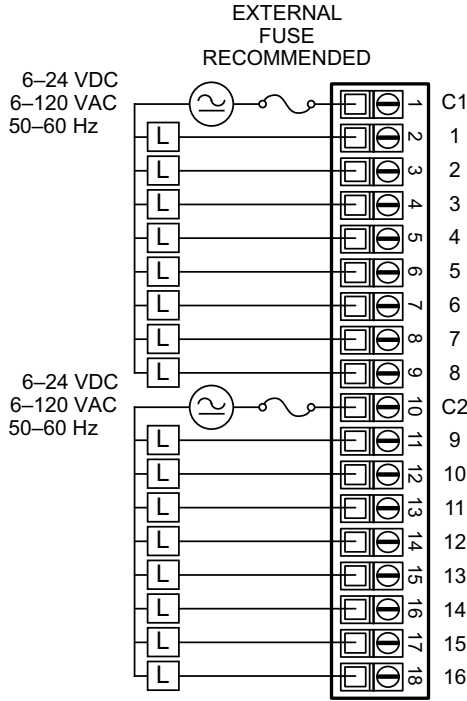

# P1-12CDRS Discrete Input / Isolated Relay Output

The P1-12CDRS Discrete Input / Isolated Relay Output Module provides eight sinking/sourcing inputs and four isolated relay outputs for use with the Productivity1000 system.

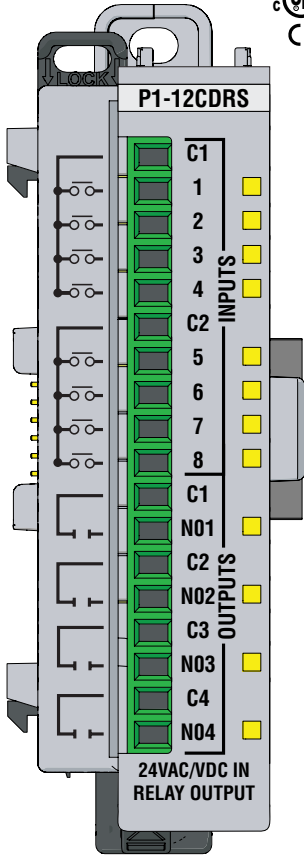

Terminal blocks sold separately

## Input Specifications

|                         |                                |
|-------------------------|--------------------------------|
| Inputs                  | 8 (sink/source)                |
| Rated Voltage           | 24 VAC/VDC                     |
| Operating Voltage Range | 20.4–27.6 VDC, Max. 30 VDC     |
| Peak Voltage Range      | 27.6 VAC/ 30 VDC,              |
| AC Frequency            | 47–63 Hz                       |
| Input Current           | 8 mA @ 24 VAC/VDC <sup>1</sup> |
| Maximum Input Current   | 10 mA @ 27.6 VC, 30 VDC        |
| Input Impedance         | 3 kΩ                           |
| Minimum ON Current      | 2.5 mA                         |
| Maximum OFF Current     | 0.5 mA                         |
| ON Voltage Level        | >9.5 VDC, >8 VAC               |
| OFF Voltage Level       | <4.5 VDC, <4 VAC               |
| OFF to ON Response      | AC: 10 ms, DC 6 ms             |
| ON to OFF Response      | AC: 20 ms, DC 10 ms            |
| Status Indicators       | Logic Side (8 points)          |
| Commons                 | 2 (4 points/common)            |

## Output Specifications

|                               |   |
|-------------------------------|---|
| Outputs per Module            | 4   |
| Rated Voltage                 | 6–30 VDC<br>6–120 VAC   |
| Operating Voltage Range       | 5–30 VDC<br>5–144 VAC   |
| Output type                   | Relay, Form A (SPST)  |
| AC Frequency                  | 47–63 Hz  |
| Maximum Output Current        | 5 A / point <sup>1</sup><br>2 A / point if used with ZIPLink Cable                  |
| Minimum Load Current          | 5 mA @ 5 VDC  |
| Maximum Inrush Current        | 5 A for 10 ms   |
| OFF to ON, ON to OFF Response | ≤10 ms  |
| Status Indicators             | Logic Side (4 points)   |
| Commons                       | 4 (1 point / common)  |
| Protection Circuit            | Not built into module – Install protection elements such as an external fuse - 8 A. |

1. See P1000 User Manual for Temperature Derating Chart for Inputs and Outputs.

We recommend using pre-wired ZIPLink cables and connection modules. See Chapter 5.

If you wish to hand-wire your module, removable terminal blocks are sold separately. Order part number P2-RTB or P2-RTB-1.



## Typical Relay Life

| Voltage & Type of Load | Operations at 1A Load Current |
|------------------------|-------------------------------|
| 30 VDC Resistive       | 100,000                       |
| 30 VDC Solenoid        | 100,000                       |
| 120 VAC Resistive      | 100,000                       |
| 120 VAC Solenoid       | 100,000                       |

# P1-12CDRS Discrete Input / Isolated Relay Output

| General Specifications           |   |
|----------------------------------|---|
| Operating Air Temperature        | 0 to 60 °C (32 to 140 °F),  |
| Storage Temperature              | -20 to +70 °C (-4 to +158 °F)   |
| Humidity                         | 5 to 95% (non-condensing)   |
| Altitude                         | 2,000 meters, max.  |
| Pollution Degree                 | 2   |
| Environmental Air                | No corrosive gases permitted  |
| Vibration                        | IEC60068-2-6 (Test Fc)  |
| Shock                            | IEC60068-2-27 (Test Ea)   |
| Overvoltage Category             | II  |
| Field to Logic Side Isolation    | Relays to Backplane 2.7 kVAC for 5 s or 800 VAC for 1 Min.<br>Discrete Input to Backplane 1.25 kVAC for 5 s or 300 VAC for 1 Min.     |
| Field to Field Isolation         | Discrete Input 8 to Relay C1 1.35 kVAC for 5 s or 400 VAC for 1 Min.<br>Relay to Relay 1.35 kVAC for 5 s or 400 VAC for 1 Min.        |
| Insulation Resistance            | >10 MΩ @ 500 VDC  |
| Heat Dissipation                 | 13500 mW  |
| Enclosure Type                   | Open equipment  |
| Module Location                  | Any I/O position in a Productivity1000 system   |
| Field Wiring                     | Use ZIPLink wiring system or removable terminal block (sold separately). See "Wiring Options" in Chapter 5.                           |
| Connector Type (sold separately) | 18-position removable terminal block  |
| Weight                           | 88 g (3.1 oz)   |
| Agency Approvals                 | UL 61010-1 and UL 61010-2-201 File E139594, Canada and USA <sup>1</sup><br>CE (EN 61131-2 EMC, EN 61010-1 and EN 61010-2-201 Safety)* |

\* See CE Declaration of Conformity for details.

1. See P1000 User Manual for Insulation Requirements for IEC/UL 61010-1 and 61010-2-201 (section 6.5 and 6.7)

| Removable Terminal Block Specifications |   |   |
|---|---|---|
| Part Number                             | P2-RTB  | P2-RTB-1  |
| Number of Positions                     | 18 screw terminals  | 18 spring clamp terminals   |
| Wire Range                              | 30–16 AWG (0.051–1.31 mm <sup>2</sup> )<br>Solid/stranded conductor<br>3/64 in. (1.2 mm) insulation max.<br>1/4 in. (6–7 mm) strip length | 28–16 AWG (0.081–1.31 mm <sup>2</sup> )<br>Solid/stranded conductor<br>3/64 in. (1.2 mm) insulation max.<br>19/64 in. (7–8 mm) strip length |
| Conductors                              | USE COPPER CONDUCTORS, 75°C or equivalent.  |   |
| Screw Driver                            | 0.1 inch (2.5 mm) maximum*  |   |
| Screw Size                              | M2  | N/A   |
| Screw Torque                            | 2.5 lb-in (0.28 N-m)  | N/A   |

\* Recommended screw driver: P/N TW-SD-MSL-1

### P1-12CDRS Insulation Requirements

Following are insulation requirements per IEC/UL 61010-1 and 61010-2-201 (Sections 6.5 and 6.7).

#### Input to Output Insulation

Basic insulation is provided between C1 of **relay outputs** and the closest input terminal. When connecting the **relay output** to a circuit that exceeds 100 VAC more than the closest **input circuit** an additional basic insulation layer must be added to the **input circuit**.

#### Output to Output Insulation

Basic insulation is provided between **relay outputs**. When connecting the **relay output** to a circuit that exceeds 100 VAC more than the closest **input circuit**, an additional basic insulation layer must be added to the adjacent **relay output** circuits.

#### Additional Basic Insulation Examples

**Supplementary insulation:** Interposing relay, additional insulating material (sec. 6.5.3)

**Automatic disconnection of the supply:** Properly sized breaker (sec. 6.5.5)

**Current or voltage Limiting device:** Properly sized fuse (sec. 6.5.6)

Basic insulation requires a clearance distance of 1 mm or more, a creepage distance of 1.48 mm or more, and dielectric voltage withstand of 1350 V<sub>rms</sub>.

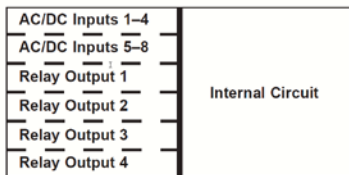

#### Input and Output Derating

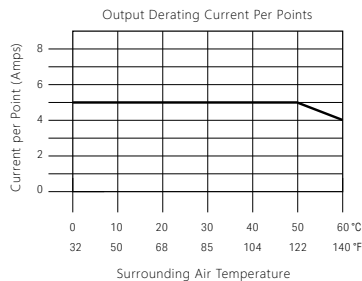
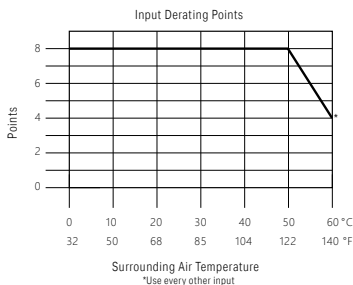

# P1-12CDRS Discrete Input / Isolated Relay Output

## Wiring Diagrams

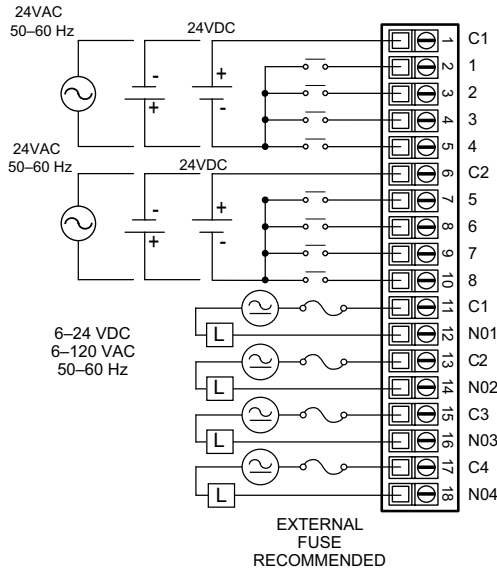

### Equivalent Input Circuit

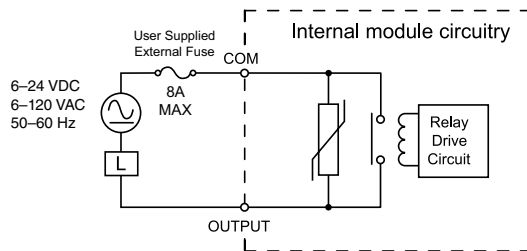
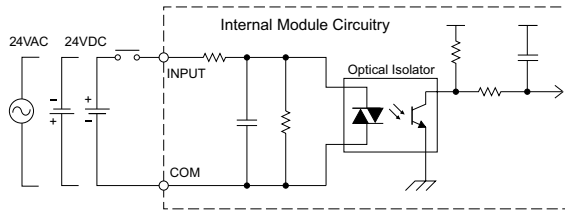

## P1-15CDD1 Input/Output

The P1-15CDD1 Input/Output Module provides eight 12–24 VDC inputs plus seven outputs that sink up to 1 A per output for loads connected to 3.3–24 VDC supplies for use with the Productivity1000 system.

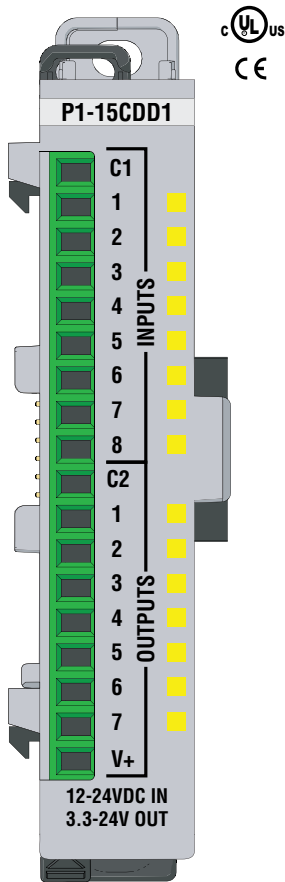

Terminal blocks sold separately

| Input Specifications          |                            |
|-------------------------------|----------------------------|
| Inputs                        | 8 (sink/source)            |
| Rated Voltage                 | 12–24 VDC                  |
| Operating Voltage Range       | 10.2–26.4 VDC, Max. 30 VDC |
| Input Current                 | 8.4 mA @ 24VDC             |
| Maximum Input Current         | 10 mA @ 26.4 VDC)          |
| Input Impedance               | 3 kΩ                       |
| ON Voltage Level              | >9 VDC                     |
| OFF Voltage Level             | <4.5 VDC                   |
| Minimum ON Current            | 1.4 mA                     |
| Maximum OFF Current           | 1 mA                       |
| OFF to ON, ON to OFF Response | 2 ms Max, 1ms Typical      |
| Status Indicators             | Logic Side (8 points)      |
| Commons                       | 1 (8 points/common)        |

| Output Specifications          |  |
|--------------------------------|--|
| Outputs per Module             | 7 sinking  |
| Rated Voltage                  | 3.3–24 VDC   |
| Operating Voltage Range        | 2.9–26.4 VDC   |
| Maximum Output Current         | 1 A per point  |
| Minimum Load Current           | 1 mA   |
| Maximum Leakage Current        | 0.3 mA @ 26.4 VDC  |
| On Voltage Drop                | 0.2 VDC @ 1 A  |
| Maximum Inrush Current         | 4 A for 50 ms, 6 A for 10 ms   |
| OFF to ON, ON to OFF Response  | ≤ 0.5 ms   |
| Status Indicators              | Logic Side (7 points)  |
| Commons                        | 1 (7 points/common)  |
| Protection Circuit             | Not built into module - Install protection elements such as external fuse. Max.8 A |
| External Power Supply Required | 12–24 VDC (-15%/+20%) @ 22 mA  |

We recommend using pre-wired ZIPLink cables and connection modules. See Chapter 5. If you wish to hand-wire your module, removable terminal blocks are sold separately. Order part number P2-RTB or P2-RTB-1



## P1-15CDD1 Input/Output (continued)

| General Specifications           |  |
|----------------------------------|--|
| Operating Air Temperature        | 0°C– 60°C (32°F–140°F)   |
| Storage Temperature              | -20°C–70°C (-4°F–158°F)  |
| Humidity                         | 5 to 95% (non-condensing)  |
| Altitude                         | 2,000 meters, max.   |
| Pollution Degree                 | 2  |
| Environmental Air                | No corrosive gases permitted   |
| Vibration                        | IEC60068-2-6 (Test Fc)   |
| Shock                            | IEC60068-2-27 (Test Ea)  |
| Field to Logic Side Isolation    | 1800 VAC applied for 1 s   |
| Insulation Resistance            | >10 MΩ @ 500 VDC   |
| Heat Dissipation                 | 1800 mW  |
| Overvoltage Category             | II   |
| Enclosure Type                   | Open equipment   |
| Module Location                  | Any I/O slot in any Productivity1000 system.   |
| Field Wiring                     | Use <b>ZIPLink</b> wiring system or removable terminal block (sold separately). See “Wiring Options” in Chapter 5.       |
| Connector Type (sold separately) | 18-position removable terminal block   |
| Weight                           | 71 g (2.5 oz)  |
| Agency Approvals                 | UL 61010-1 and UL 61010-2-201 File E139594, Canada and USA<br>CE (EN 61131-2 EMC, EN 61010-1 and EN 61010-2-201 Safety)* |

\* See CE Declaration of Conformity for details..

| Removable Terminal Block Specifications |   |   |
|---|---|---|
| Part Number                             | P1-10RTB  | P1-10RTB-1  |
| Number of Positions                     | 10 screw terminals  | 10 spring clamp terminals   |
| Wire Range                              | 30–16 AWG (0.051–1.31 mm <sup>2</sup> )<br>Solid/stranded conductor<br>3/64 in. (1.2 mm) insulation max.<br>1/4 in. (6–7 mm) strip length | 28–16 AWG (0.081–1.31 mm <sup>2</sup> )<br>Solid/stranded conductor<br>3/64 in. (1.2 mm) insulation max.<br>19/64 in. (7–8 mm) strip length |
| Conductors                              | USE COPPER CONDUCTORS, 75°C or equivalent.  |   |
| Screw Driver                            | 0.1 inch (2.5 mm) maximum*  |   |
| Screw Size                              | M2  | N/A   |
| Screw Torque                            | 2.5 lb-in (0.28 N-m)  | N/A   |

\* Recommended screw driver: P/N TW-SD-MSL-1

# P1-15CDD1 Input/Output (continued)

## Wiring Diagrams

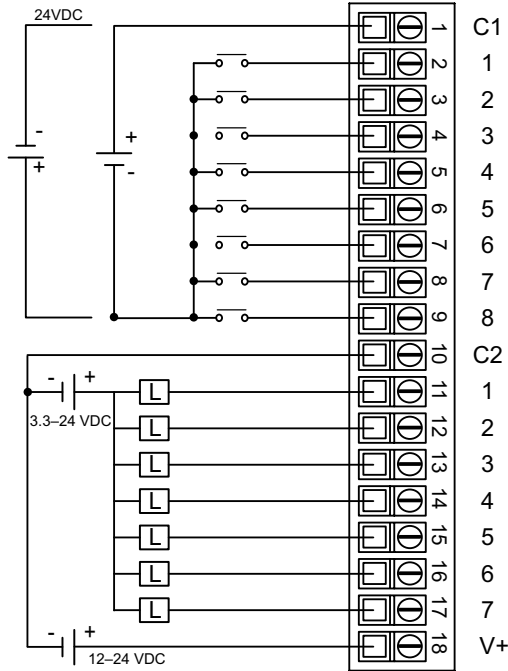

Typical Input Circuit

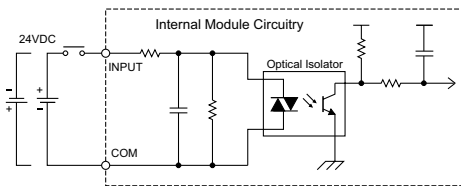

Typical Output Circuit

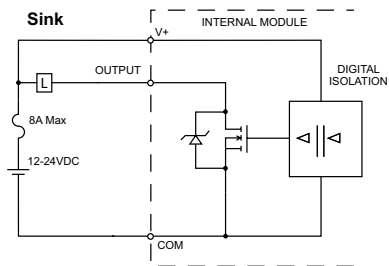

## P1-15CDD2 Input/Output

The P1-15CDD2 Input/Output Module provides eight 12–24 VDC inputs plus seven 12–24 VDC outputs that source up to 1A per output to loads connected to ground for use with the Productivity1000 system.

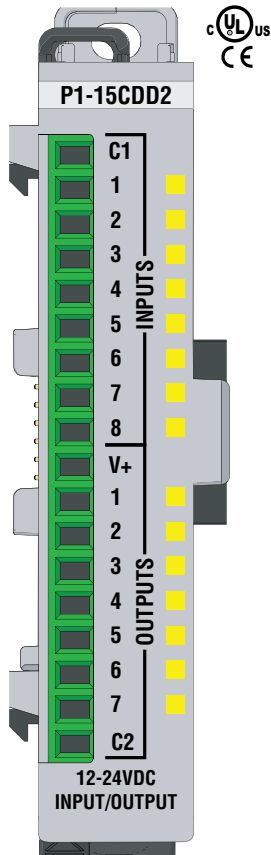

Terminal blocks sold separately

| Input Specifications          |                           |
|-------------------------------|---------------------------|
| Inputs per Module             | 8 (Sinking/Sourcing)      |
| Rated Voltage                 | 12–24 VDC                 |
| Operating Voltage Range       | 10.2–26.4 VDC, Max 30 VDC |
| Input Current                 | 8.4 mA @ 24 VDC           |
| Maximum Input Current         | 10 mA @ 28.8 VDC)         |
| Input Impedance               | 3 kΩ                      |
| Minimum ON Current            | 1.4 mA                    |
| Maximum OFF Current           | 1 mA                      |
| ON Voltage Level              | >9 VDC                    |
| OFF Voltage Level             | < 4.5 VDC                 |
| OFF to ON, ON to OFF Response | 2 ms Max, 1 ms Typical    |
| Status Indicators             | Logic Side (8 points)     |
| Commons                       | 1 (8 points/common)       |

| Output Specifications          |                               |
|--------------------------------|-------------------------------|
| Outputs per Module             | 7 (sourcing)                  |
| Voltage Rating                 | 12–24 VDC                     |
| Operating Voltage Range        | 10.2–28.8 VDC                 |
| Maximum Output Current         | 1 A per point                 |
| Minimum Load Current           | 1 mA                          |
| Maximum Leakage Current        | 0.3 mA @ 28.8 VDC             |
| On Voltage Drop                | 25mV                          |
| Maximum Inrush Current         | 4 A for 50 ms, 6 A for 10 ms  |
| OFF to ON, ON to OFF Response  | 0.5 ms                        |
| Status Indicators              | Logic Side (7 points)         |
| Commons                        | 1 (7 points/common)           |
| Maximum Applicable Fuse        | 8 A                           |
| External Power Supply Required | 12–24 VDC (-15%/+20%) @ 22 mA |

We recommend using pre-wired ZIPLink cables and connection modules. See Chapter 5. If you wish to hand-wire your module, removable terminal blocks are sold separately. Order part number P2-RTB or P2-RTB-1.



## P1-15CDD2 Input/Output (continued)

| General Specifications           |  |
|----------------------------------|--|
| Operating Air Temperature        | 0°C– 60°C (32°F–140°F)   |
| Storage Temperature              | -20°C–70°C (-4°F–158°F)  |
| Humidity                         | 5 to 95% (non-condensing)  |
| Environmental Air                | No corrosive gases permitted   |
| Vibration                        | IEC60068-2-6 (Test Fc)   |
| Shock                            | IEC60068-2-27 (Test Ea)  |
| Field to Logic Side Isolation    | 1800 VAC applied for 1 s   |
| Insulation Resistance            | >10 MΩ @ 500 VDC   |
| Heat Dissipation                 | 1800 mW  |
| Enclosure Type                   | Open equipment   |
| Module Keying                    | Electronic   |
| Module Location                  | Any I/O position in a Productivity1000 system  |
| Field Wiring                     | Use ZIPLink wiring system or removable terminal block (sold separately). See "Wiring Options" in Chapter 5.              |
| Connector Type (sold separately) | 18-position removable terminal block   |
| Weight                           | 71 g (2.5 oz)  |
| Agency Approvals                 | UL 61010-1 and UL 61010-2-201 File E139594, Canada and USA<br>CE (EN 61131-2 EMC, EN 61010-1 and EN 61010-2-201 Safety)* |

\* See CE Declaration of Conformity for details.

| Removable Terminal Block Specifications |   |   |
|---|---|---|
| Part Number                             | P1-10RTB  | P1-10RTB-1  |
| Number of Positions                     | 10 screw terminals  | 10 spring clamp terminals   |
| Wire Range                              | 30–16 AWG (0.051–1.31 mm <sup>2</sup> )<br>Solid/stranded conductor<br>3/64 in. (1.2 mm) insulation max.<br>1/4 in. (6–7 mm) strip length | 28–16 AWG (0.081–1.31 mm <sup>2</sup> )<br>Solid/stranded conductor<br>3/64 in. (1.2 mm) insulation max.<br>19/64 in. (7–8 mm) strip length |
| Conductors                              | USE COPPER CONDUCTORS, 75°C or equivalent.  |   |
| Screw Driver                            | 0.1 inch (2.5 mm) maximum*  |   |
| Screw Size                              | M2  | N/A   |
| Screw Torque                            | 2.5 lb·in (0.28 N·m)  | N/A   |

\* Recommended screw driver: P/N TW-SD-MSL-1

# P1-15CDD2 Input/Output (continued)

## Wiring Diagrams

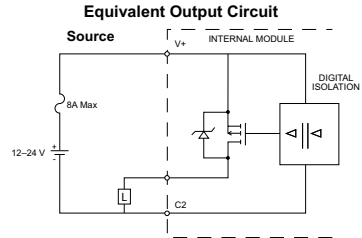
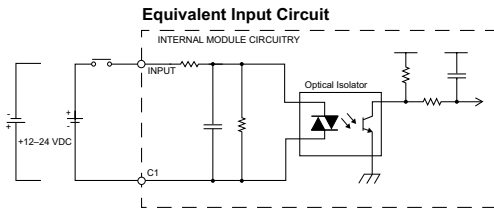
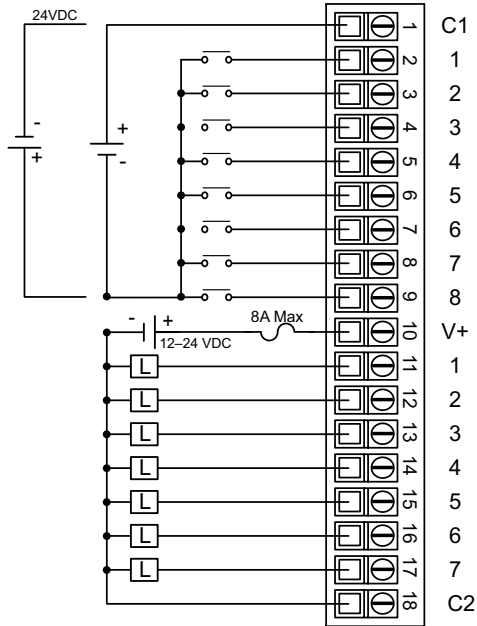

# P1-16CDR Discrete Input/ Relay Output

The P1-16CDR Discrete Input / Relay Output Module provides eight 24 VAC/VDC inputs and eight relay outputs for use with the Productivity1000 system.

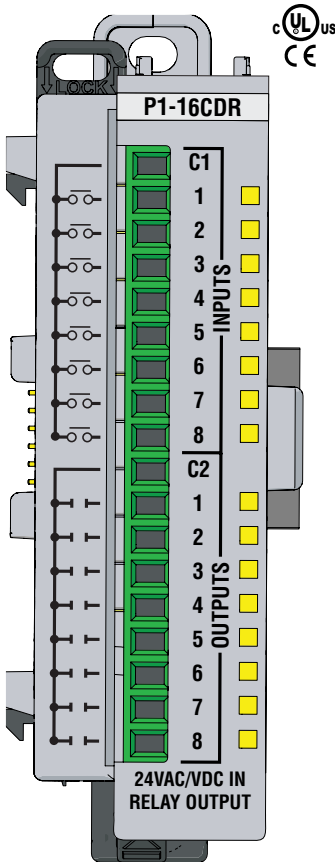

Terminal blocks sold separately



We recommend using pre-wired ZIPLink cables and connection modules. See Chapter 5. If you wish to hand-wire your module, removable terminal blocks are sold separately. Order part number P2-RTB or P2-RTB-1.

## Input Specifications

|                         |   |
|-------------------------|---|
| Inputs per Module       | 8 (sink/source)                         |
| Rated Voltage           | 24 VAC/VDC                              |
| Operating Voltage Range | 20.4–27.6 VAC/VDC, Max 27.6 VAC, 30 VDC |
| AC Frequency            | 47–63 Hz                                |
| Input Current           | 8mA @ 24 VAC/VDC                        |
| Maximum Input Current   | 10mA @ 27.6 VAC                         |
| Minimum ON Current      | 2.5 mA                                  |
| Maximum OFF Current     | 0.5 mA                                  |
| ON Voltage Level        | >9.5 VDC, >8 VAC                        |
| OFF Voltage Level       | <4.5 VDC, <4 VAC                        |
| OFF to ON Response      | AC: 10 ms, DC: 6 ms                     |
| ON to OFF Response      | AC: 20 ms, DC: 10 ms                    |
| Status Indicators       | Logic Side (8 points)                   |
| Commons                 | 1 (8 points/common)                     |

## Output Specifications

|                               |  |
|-------------------------------|--|
| Outputs per Module            | 8  |
| Rated Voltage                 | 6–30 VDC<br>6–120 VAC  |
| Operating Voltage Range       | 5–30 VDC<br>5–144 VAC  |
| Output Type                   | Relay, Form A (SPST)   |
| AC Frequency                  | 47–63 Hz   |
| Maximum Output Current        | 1 A/point, 8 A/common for both AC and DC<br>1 A/point,<br>8 A/common for both is used with ZIPLink cable |
| Minimum Load Current          | 5 mA @ 5 VDC   |
| Maximum Inrush Current        | 5 A for 10 ms  |
| OFF to ON, ON to OFF Response | ≤ 10ms   |
| Status Indicators             | Logic Side (8 points)  |
| Commons                       | 1 (8 point / common)   |
| Maximum Applicable Fuse       | 8 A  |

## P1-16CDR Discrete Input/ Relay Output (continued)

| General Specifications           |  |
|----------------------------------|--|
| Operating Air Temperature        | 0°C– 60°C (32°F–140°F)   |
| Storage Temperature              | -20°C–70°C (-4°F–158°F)  |
| Humidity                         | 5 to 95% (non-condensing)  |
| Environmental Air                | No corrosive gases permitted   |
| Vibration                        | IEC60068-2-6 (Test Fc)   |
| Shock                            | IEC60068-2-27 (Test Ea)  |
| Field to Logic Side Isolation    | 1800 VAC applied for 1 s   |
| Insulation Resistance            | >10 MΩ @ 500 VDC   |
| Heat Dissipation                 | 2730 mW  |
| Enclosure Type                   | Open equipment   |
| Module Location                  | Any I/O position in a Productivity®1000 system.  |
| Field Wiring                     | Use <b>ZIPLink</b> wiring system or removable terminal block (sold separately). See "Wiring Options" in Chapter 5.       |
| Connector Type (sold separately) | 18-position removable terminal block   |
| Weight                           | 88 g (3.2 oz)  |
| Agency Approvals                 | UL 61010-1 and UL 61010-2-201 File E139594, Canada and USA<br>CE (EN 61131-2 EMC, EN 61010-1 and EN 61010-2-201 Safety)* |

\* See CE Declaration of Conformity for details.

| Removable Terminal Block Specifications |   |   |
|---|---|---|
| Part Number                             | P1-10RTB  | P1-10RTB-1  |
| Number of Positions                     | 10 screw terminals  | 10 spring clamp terminals   |
| Wire Range                              | 30–16 AWG (0.051–1.31 mm <sup>2</sup> )<br>Solid/stranded conductor<br>3/64 in. (1.2 mm) insulation max.<br>1/4 in. (6–7 mm) strip length | 28–16 AWG (0.081–1.31 mm <sup>2</sup> )<br>Solid/stranded conductor<br>3/64 in. (1.2 mm) insulation max.<br>19/64 in. (7–8 mm) strip length |
| Conductors                              | USE COPPER CONDUCTORS, 75°C or equivalent.  |   |
| Screw Driver                            | 0.1 inch (2.5 mm) maximum*  |   |
| Screw Size                              | M2  | N/A   |
| Screw Torque                            | 2.5 lb-in (0.28 N-m)  | N/A   |

\* Recommended screw driver: P/N TW-SD-MSL-1

# P1-16CDR Discrete Input/ Relay Output Module (continued)

## Wiring Diagrams

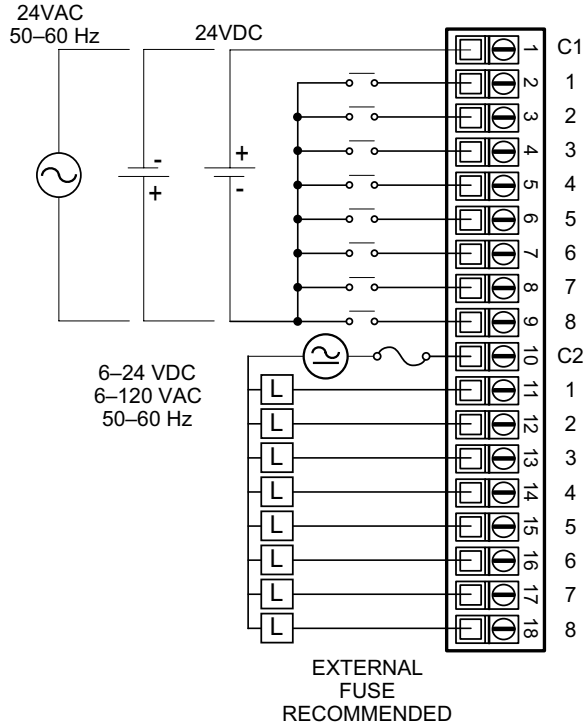

**Equivalent Output Circuit**

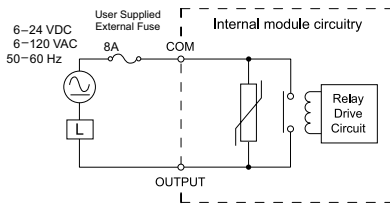

**Equivalent Input Circuit**

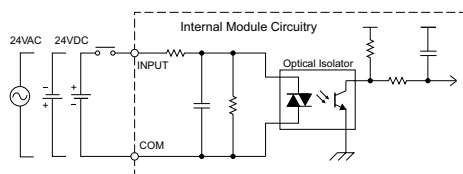

# ANALOG I/O SPECIFICATIONS

---



# CHAPTER 3

## In This Chapter...

|   |             |
|---|-------------|
| <b>Analog I/O Modules Overview.....</b> | <b>3-3</b>  |
| <b>Analog I/O Modules.....</b>          | <b>3-4</b>  |
| Analog Input Modules.....               | 3-4         |
| Analog Output Modules.....              | 3-4         |
| Analog Input/Output Modules.....        | 3-5         |
| <b>P1-04AD Analog Input.....</b>        | <b>3-6</b>  |
| Wiring Diagrams.....                    | 3-8         |
| Module Configuration.....               | 3-9         |
| <b>P1-04AD-1 Analog Input.....</b>      | <b>3-10</b> |
| Wiring Diagrams.....                    | 3-12        |
| Module Configuration.....               | 3-13        |
| <b>P1-04AD-2 Analog Input.....</b>      | <b>3-14</b> |
| Wiring Diagrams.....                    | 3-16        |
| Module Configuration.....               | 3-17        |
| <b>P1-04ADL-1 Analog Input.....</b>     | <b>3-18</b> |
| Wiring Diagrams.....                    | 3-20        |
| Module Configuration.....               | 3-21        |
| <b>P1-04ADL-2 Analog Input.....</b>     | <b>3-22</b> |
| Wiring Diagrams.....                    | 3-24        |
| Module Configuration.....               | 3-25        |
| <b>P1-08ADL-1 Analog Input.....</b>     | <b>3-26</b> |
| Wiring Diagrams.....                    | 3-28        |
| Module Configuration.....               | 3-29        |

## Table of Contents

---

|  |             |
|--|-------------|
| <b>P1-08ADL-2 Analog Input</b> .....                   | <b>3-30</b> |
| Wiring Diagrams.....                                   | 3-32        |
| Module Configuration.....                              | 3-33        |
| <b>P1-04RTD Analog Input</b> .....                     | <b>3-34</b> |
| Wiring Diagrams.....                                   | 3-37        |
| Module Configuration.....                              | 3-38        |
| <b>P1-04THMS Analog Input</b> .....                    | <b>3-39</b> |
| Wiring Diagrams.....                                   | 3-41        |
| Module Configuration.....                              | 3-43        |
| <b>P1-04THM Analog Input</b> .....                     | <b>3-44</b> |
| Wiring Diagrams.....                                   | 3-46        |
| Module Configuration.....                              | 3-48        |
| <b>P1-04NTC Thermistor</b> .....                       | <b>3-49</b> |
| Wiring Diagrams.....                                   | 3-51        |
| Module Configuration.....                              | 3-52        |
| <b>P1-04DAL-1 Analog Output</b> .....                  | <b>3-53</b> |
| Wiring Diagrams.....                                   | 3-55        |
| Module Configuration.....                              | 3-56        |
| <b>P1-04DAL-2 Analog Output</b> .....                  | <b>3-57</b> |
| Wiring Diagrams.....                                   | 3-59        |
| Module Configuration.....                              | 3-60        |
| <b>P1-08DAL-1 Analog Output</b> .....                  | <b>3-61</b> |
| Wiring Diagrams.....                                   | 3-63        |
| Module Configuration.....                              | 3-64        |
| <b>P1-08DAL-2 Analog Output</b> .....                  | <b>3-65</b> |
| Wiring Diagrams.....                                   | 3-67        |
| Module Configuration.....                              | 3-68        |
| <b>P1-4ADL2DAL-1 Current Analog Input/Output</b> ..... | <b>3-69</b> |
| Wiring Diagrams.....                                   | 3-72        |
| Module Configuration.....                              | 3-73        |
| <b>P1-4ADL2DAL-2 Voltage Analog Input/Output</b> ..... | <b>3-74</b> |
| Wiring Diagrams.....                                   | 3-77        |
| Module Configuration.....                              | 3-78        |

## Analog I/O Modules Overview

A variety of analog I/O modules are available for use with Productivity®1000 system.

Each I/O module is identified as an "Input" or "Output" module on its front panel using the color coding scheme listed below. See Chapter 2 for discrete I/O module specifications and Chapter 6 for communications wiring and connectivity information. The following pages contain the analog I/O module specifications and associated wiring diagrams.

There are 16 analog I/O modules available; ten Input, four Output modules and two Input/Output combination modules. The specifications and wiring diagrams, along with configuration and signal scaling information, are in this chapter.

Use the hardware configuration tool in the Productivity Suite programming software to setup the I/O modules. See the Productivity Suite help file for in-depth configuration and programming concepts.

### Analog Input Modules

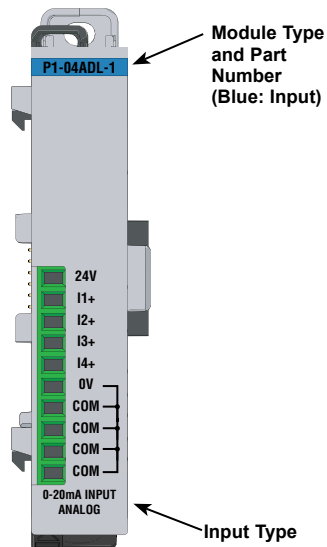

### Analog Output Modules

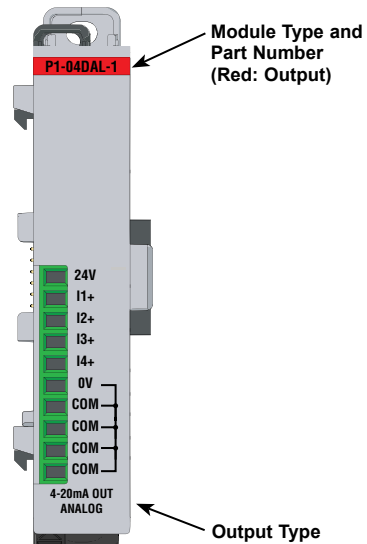

# Analog I/O Modules

## Analog Input Modules

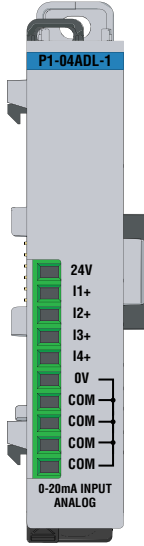

| Productivity1000 Analog Input Modules |                    |                                |          |
|---------------------------------------|--------------------|--------------------------------|----------|
| Part Number                           | Number of Channels | Description                    | See Page |
| P1-04AD                               | 4                  | Analog Input (Current/Voltage) | 3-6      |
| P1-04AD-1                             | 4                  | Analog Input (Current)         | 3-10     |
| P1-04AD-2                             | 4                  | Analog Input (Voltage)         | 3-14     |
| P1-04ADL-1                            | 4                  | Analog Input (Current)         | 3-18     |
| P1-04ADL-2                            | 4                  | Analog Input (Voltage)         | 3-22     |
| P1-08ADL-1                            | 8                  | Analog Input (Current)         | 3-26     |
| P1-08ADL-2                            | 8                  | Analog Input (Voltage)         | 3-30     |
| P1-04RTD                              | 4                  | RTD Input                      | 3-34     |
| P1-04THMS                             | 4                  | Analog SS Thermocouple Input   | 3-39     |
| P1-04THM                              | 4                  | Analog Thermocouple Input      | 3-44     |
| P1-04NTC                              | 4                  | Analog Thermistor Input        | 3-49     |

## Analog Output Modules

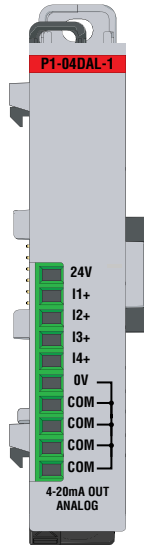

| Productivity1000 Analog Output Modules |                    |                         |          |
|--|--------------------|-------------------------|----------|
| Part Number                            | Number of Channels | Description             | See Page |
| P1-04DAL-1                             | 4                  | Analog Output (Current) | 3-53     |
| P1-04DAL-2                             | 4                  | Analog Output (Voltage) | 3-57     |
| P1-08DAL-1                             | 8                  | Analog Output (Current) | 3-61     |
| P1-08DAL-2                             | 8                  | Analog Output (Voltage) | 3-66     |

## Analog Input/Output Modules

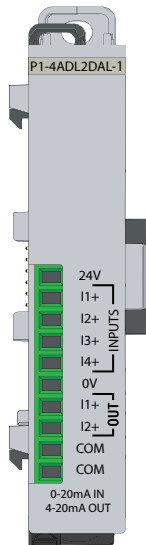

### Productivity1000 Analog Input/Output Modules

| Part Number   | Number of Channels | Description                          | See Page |
|---------------|--------------------|--------------------------------------|----------|
| P1-4ADL2DAL-1 | 4/2                | Analog Input/Analog Output (Current) | 3-69     |
| P1-4ADL2DAL-2 | 4/2                | Analog Input/Analog Output (Voltage) | 3-74     |

# P1-04AD Analog Input

The P1-04AD Voltage/Current Analog Input Module provides four channels for receiving  $\pm 5\text{VDC}$ ,  $\pm 10\text{VDC}$ ,  $0\text{--}5\text{ VDC}$ ,  $0\text{--}10\text{ VDC}$ , and  $0\text{ to }20\text{mA}$  signals for use with the Productivity@1000 system.

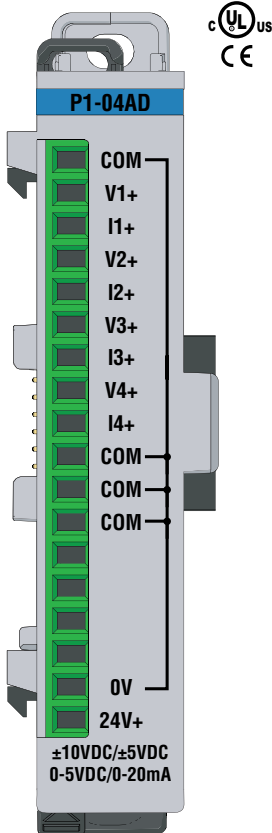

Terminal block sold separately.

| Input Specifications                            |  |
|---|--|
| Inputs per Module                               | 4  |
| Module Signal Input Range                       | $\pm 5\text{ VDC}$ , $\pm 10\text{ VDC}$ , $0\text{--}5\text{ VDC}$ , $0\text{--}10\text{ VDC}$ , $0\text{--}20\text{ mA}$   |
| Signal Resolution                               | 16-bit   |
| Resolution Value of LSB (least significant bit) | $\pm 5\text{ V}=152\ \mu\text{V}$ , $\pm 10\text{ V}=305\ \mu\text{V}$<br>$0\text{--}5\text{ V}=76\ \mu\text{V}$ , $0\text{--}10\text{ V}=152\ \mu\text{V}$ ,<br>$0\text{--}20\text{ mA}=0.305\ \mu\text{A}$ per count<br>(1LSB = 1 count) |
| Data Range                                      | $0\text{--}65535$ counts unipolar<br>$-32768$ to $+32767$ counts bipolar   |
| Input Type                                      | Single-ended (1 common)  |
| Maximum Continuous Overload                     | $\pm 31\text{ mA}$ , current input<br>$\pm 100\text{ V}$ , voltage input   |
| Input Impedance                                 | $1.1\text{ M}\ \pm 10\%$ voltage input<br>$250\ \Omega\ \pm 0.1\%$ $1/4\text{W}$ current input   |
| Filter Characteristics                          | Low Pass 1st order, $-3\text{dB}$ @ $48\text{Hz}$  |
| Sample Duration Time                            | $3.5\text{ ms}$ per channel<br>(Does not include ladder scan time)   |
| All Channel Update Rate                         | $15\text{ ms}$   |
| Open Circuit Detection Time                     | Zero reading within $1\text{ s}$ (current input only)  |
| Conversion Method                               | Successive approximation   |
| Accuracy vs Temperature                         | $\pm 10\text{ PPM}/^\circ\text{C}$ maximum   |
| Maximum Inaccuracy                              | $0.1\%$ of range voltage, $0.2\%$ of range current<br>(Including temperature drift)  |
| Linearity Error (end to end)                    | $\pm 0.01\%$ of range max., $\pm 10\text{ V}$ & $\pm 5\text{V}$<br>$\pm 0.015\%$ of range max., $0\text{--}5\text{ V}$<br>$0\text{--}20\text{ mA}$ Monotonic with no missing codes   |
| Input Stability and Repeatability               | $\pm 0.035\%$ of range (after $10\text{ min.}$ warm-up)  |
| Full Scale Calibration Error                    | $\pm 0.2\%$ of range maximum   |
| Offset Calibration Error                        | $\pm 0.065\%$ of range maximum   |
| Max Crosstalk                                   | $-96\text{dB}$ , of range maximum  |
| Recommended Fuse (external)                     | Edison S500-32-R, $0.032\text{ A}$ fuse<br>(On current inputs only)  |
| External Power Supply Required                  | $24\text{ VDC}$ ( $-20\%$ / $+25\%$ ), $35\text{ mA}$  |

We recommend using pre-wired ZIPLink cables and connection modules. See Chapter 5. If you wish to hand-wire your module, removable terminal blocks are sold separately. Order part number P2-RTB or P2-RTB-1



## P1-04AD Analog Input (continued)

| General Specifications          |  |
|---------------------------------|--|
| Operating Temperature           | 0°C– 60 °C (32 to 140 °F)  |
| Storage Temperature             | -20 to +70 °C (-4 to +158 °F)  |
| Humidity                        | 5 to 95% (non-condensing)  |
| Altitude                        | 2,000 meters, max.   |
| Pollution Degree                | 2  |
| Environmental Air               | No corrosive gases permitted   |
| Vibration                       | IEC60068-2-6 (Test Fc)   |
| Shock                           | IEC60068-2-27 (Test Ea)  |
| Field to Logic Side Isolation   | 1800VAC applied for 1s   |
| Insulation Resistance           | >10 MΩ @ 500VDC  |
| Heat Dissipation                | 1400 mW  |
| Overtoltage Category            | II   |
| Enclosure Type                  | Open equipment   |
| Field Wiring                    | Removable terminal block (sold separately).<br>Use <b>ZIP</b> Link wiring system optional.<br>See “Wiring Options” in Chapter 5. |
| Terminal Type (sold separately) | 18-position removable terminal block   |
| Weight                          | 71 g (2.5 oz)  |
| Agency Approvals                | UL 61010-1 and UL 61010-2-201 File E139594, Canada and USA<br>CE (EN 61131-2 EMC, EN 61010-1 and EN 61010-2-201 Safety)*         |

| Removable Terminal Block Specifications |   |   |
|---|---|---|
| Part Number                             | P1-10RTB  | P1-10RTB-1  |
| Number of positions                     | 10 screw terminals  | 10 spring clamp terminals   |
| Wire Range                              | 30–16 AWG (0.051–1.31 mm <sup>2</sup> )<br>Solid/stranded conductor<br>3/64 in. (1.2 mm) insulation max.<br>1/4 in (6– 7 mm) strip length | 28–16 AWG (0.081–1.31 mm <sup>2</sup> )<br>Solid/stranded conductor<br>3/64 in (1.2 mm) insulation max.<br>19/64 in (7–8 mm) strip length |
| Conductors                              | USE COPPER CONDUCTORS, 75°C or equivalent.  |   |
| Screw Driver                            | 0.1 in (2.5 mm) maximum*  |   |
| Screw Size                              | M2  | N/A   |
| Screw Torque                            | 2.5 lb·in (0.28 N·m)  | N/A   |

\* Recommended screw driver P/N: TW-SD-MSL-1.

# P1-04AD Analog Input (continued)

## Wiring Diagrams

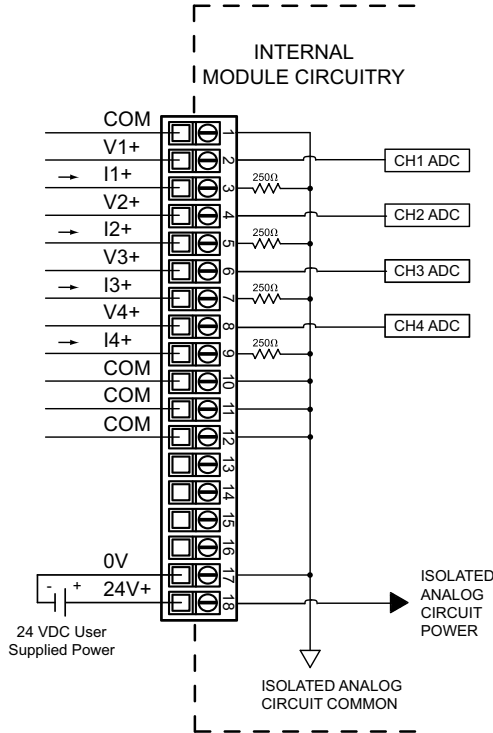

### Current Sinking Input Circuits

An Edison S500-32-R 0.032A fast-acting fuse is recommended for all current loops.

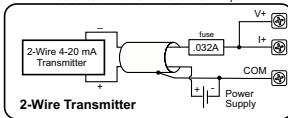

**2-Wire Transmitter**

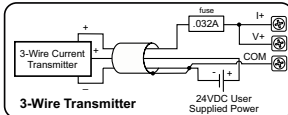

**3-Wire Transmitter**

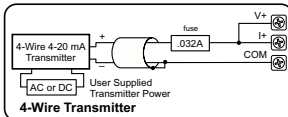

**4-Wire Transmitter**

**Notes:**

1. Shield connected to signal source common.
2. If current is chosen, I+ MUST be jumpered to V+. For example, when using 4-20 mA source for Input 3, I3+ must be connected to V3+.

### Voltage Input Circuits

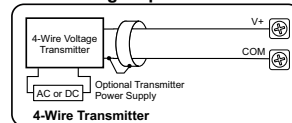

**4-Wire Transmitter**

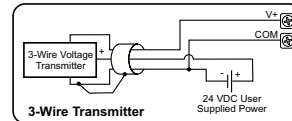

**3-Wire Transmitter**

## P1-04AD Analog Input (continued)

### Module Configuration

Using the Hardware Configuration tool in the Productivity Suite programming software, drag and drop the P1-04AD module into the base configuration.

| Point | User Tagname  | Ch. Select                          | Range   | Under Range Error | Over Range Error |
|-------|---------------|-------------------------------------|---------|-------------------|------------------|
| 1     | AIS32-0.1.1.1 | <input checked="" type="checkbox"/> | 0-20 ma | MST-0.1.1.57      | MST-0.1.1.89     |
| 2     | AIS32-0.1.1.2 | <input checked="" type="checkbox"/> | 0-20 ma | MST-0.1.1.58      | MST-0.1.1.90     |
| 3     | AIS32-0.1.1.3 | <input checked="" type="checkbox"/> | 0-20 ma | MST-0.1.1.59      | MST-0.1.1.91     |
| 4     | AIS32-0.1.1.4 | <input checked="" type="checkbox"/> | 0-20 ma | MST-0.1.1.60      | MST-0.1.1.92     |

| Status Bit    | User Tagname |
|---------------|--------------|
| Module Failed | MST-0.1.1.25 |
| Missing 24V   | MST-0.1.1.26 |

The “Under Range Error” bit for each channel activates for a signal around  $0\text{mA} \pm \text{offset error}$ .

The “Over Range Error” bit for each channel activates for a signal around  $19.999\text{ mA} \pm \text{gain error}$ .

### P1-04AD-1 Analog Input

The P1-04AD-1 Current Analog Input Module provides four channels for receiving 0 to 20mA signals for use with the Productivity@1000 system.

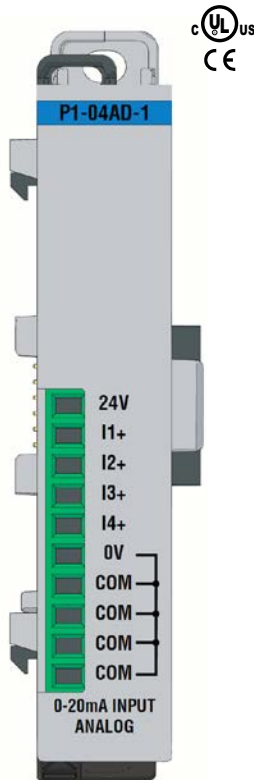

| Input Specifications                            |  |
|---|--|
| Inputs per Module                               | 4  |
| Module Signal Input Range                       | 0–20 mA  |
| Signal Resolution                               | 16-bit   |
| Resolution Value of LSB (least significant bit) | 0–20 mA=0.305 $\mu$ A per count (1LSB = 1 count)         |
| Data Range                                      | 0-65535 counts   |
| Input Type                                      | Single-ended (1 common)                                  |
| Maximum Continuous Overload                     | $\pm$ 31mA   |
| Input Impedance                                 | 250 $\pm$ 0.1% 1/4 W                                     |
| Filter Characteristics                          | Low Pass, -3dB @ 100Hz                                   |
| Sample Duration Time                            | 9ms per channel (Does not include ladder scan time)      |
| All Channel Update Rate                         | 80ms   |
| Open Circuit Detection Time                     | Zero reading within 1s                                   |
| Conversion Method                               | Successive approximation                                 |
| Accuracy vs Temperature                         | $\pm$ 25PPM / $^{\circ}$ C maximum                       |
| Maximum Inaccuracy                              | 0.1% of range (Including temperature drift)              |
| Linearity Error (end to end)                    | $\pm$ 0.015% of range<br>Monotonic with no missing codes |
| Input Stability and Repeatability               | $\pm$ 0.015% of range (after 10 min. warm-up)            |
| Full Scale Calibration Error                    | $\pm$ 0.015% of range maximum                            |
| Offset Calibration Error                        | $\pm$ 0.015% of range maximum                            |
| Max Crosstalk                                   | -76dB, $\pm$ 10 LSB                                      |
| Recommended Fuse (external)                     | Edison S500-32-R, 0.032 A fuse                           |
| External Power Supply Required                  | 24VDC (-20% / + 25%), 35mA                               |

Terminal block sold separately.

We recommend using pre-wired ZIPLink cables and connection modules. See Chapter 5. If you wish to hand-wire your module, removable terminal blocks are sold separately. Order part number P1-10RTB or P1-10RTB-1



## P1-04AD-1 Analog Input (continued)

| General Specifications             |   |
|------------------------------------|---|
| Operating Temperature              | 0°C– 60°C (32°F–140°F)  |
| Storage Temperature                | -20°C–70°C (-4°F–158°F)   |
| Humidity                           | 5 to 95% (non-condensing)   |
| Altitude                           | 2,000 meters, max.  |
| Pollution Degree                   | 2   |
| Environmental Air                  | No corrosive gases permitted  |
| Vibration                          | IEC60068-2-6 (Test Fc)  |
| Shock                              | IEC60068-2-27 (Test Ea)   |
| Field to Logic Side Isolation      | 1800VAC applied for 1s  |
| Insulation Resistance              | >10MΩ @ 500VDC  |
| Heat Dissipation                   | 1400mW  |
| Overtoltage Category               | II  |
| Enclosure Type                     | Open equipment  |
| Module Location                    | Any I/O position in a Productivity1000 system   |
| Field Wiring                       | Removable terminal block (sold separately).<br>Use <b>ZIPLink</b> wiring system optional.<br>See “Wiring Options” in Chapter 5. |
| Terminal Type<br>(sold separately) | 10-position removable terminal block  |
| Weight                             | 58g (2.0 oz)  |
| Agency Approvals                   | UL 61010-1 and UL 61010-2-201 File E139594, Canada and USA<br>CE (EN 61131-2 EMC, EN 61010-1 and EN 61010-2-201 Safety)*        |

| Removable Terminal Block Specifications |   |   |
|---|---|---|
| Part Number                             | P1-10RTB  | P1-10RTB-1  |
| Positions                               | 10 screw terminals  | 10 spring clamp terminals   |
| Wire Range                              | 30–16 AWG (0.051–1.31 mm <sup>2</sup> )<br>Solid / stranded conductor<br>3/64 in. (1.2 mm) insulation max.<br>1/4 in (6– 7 mm) strip length | 28–16 AWG (0.081–1.31 mm <sup>2</sup> )<br>Solid / stranded conductor<br>3/64 in (1.2 mm) insulation max.<br>19/64 in (7–8 mm) strip length |
| Conductors                              | USE COPPER CONDUCTORS, 75°C or equivalent.  |   |
| Screw Driver                            | 0.1 in (2.5 mm) maximum*  |   |
| Screw Size                              | M2  | N/A   |
| Screw Torque                            | 2.5 lb-in (0.28 N·m)  | N/A   |

\* Recommended screw driver P/N: TW-SD-MSL-1.

# P1-04AD-1 Analog Input (continued)

## Wiring Diagrams

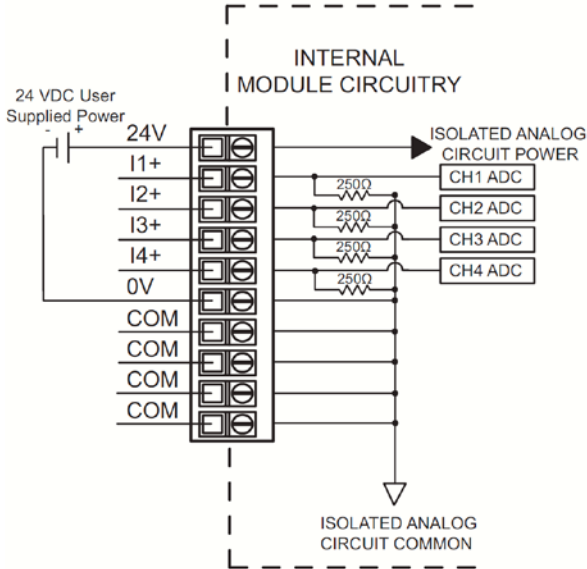

### Current Input Circuits

An Edison S500-32-R 0.032 A fast-acting fuse is recommended for current loops.

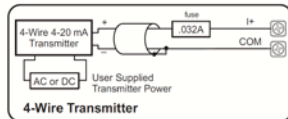
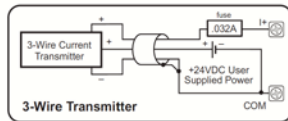
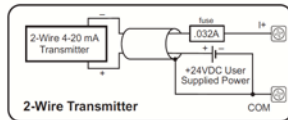

## P1-04AD-1 Analog Input (continued)

### Module Configuration

Using the Hardware Configuration tool in the Productivity Suite programming software, drag and drop the P1-04AD-1 module into the configuration.

P1-04AD-1

4CH, 16-BIT, CURRENT, 0-20mA, ANALOG INPUT

Add Default Tags Remove Default Tags

| Point | User Tagname  | Ch. Select                          | Under Range Error | Over Range Error |
|-------|---------------|-------------------------------------|-------------------|------------------|
| 1     | AIS32-0.1.1.1 | <input checked="" type="checkbox"/> | MST-0.1.1.57      | MST-0.1.1.89     |
| 2     | AIS32-0.1.1.2 | <input checked="" type="checkbox"/> | MST-0.1.1.58      | MST-0.1.1.90     |
| 3     | AIS32-0.1.1.3 | <input checked="" type="checkbox"/> | MST-0.1.1.59      | MST-0.1.1.91     |
| 4     | AIS32-0.1.1.4 | <input checked="" type="checkbox"/> | MST-0.1.1.60      | MST-0.1.1.92     |

| Status Bit    | User Tagname |
|---------------|--------------|
| Module Failed | MST-0.1.1.25 |
| Missing 24V   | MST-0.1.1.26 |

Module Info Monitor OK Cancel Help

The “Under Range Error” bit for each channel activates for a signal around  $0\text{mA} \pm \text{offset error}$ .  
 The “Over Range Error” bit for each channel activates for a signal around  $19.999 \text{ mA} \pm \text{gain error}$ .

# P1-04AD-2 Analog Input

The P1-04AD-2 Voltage Analog Input Module provides four channels for receiving 0–10 VDC signals for use with the Productivity®1000 system.

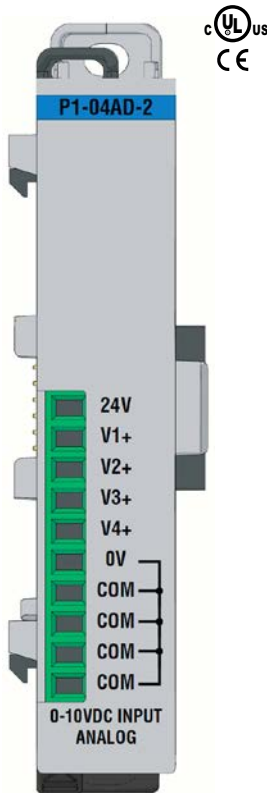

| Input Specifications                            |   |
|---|---|
| Inputs per Module                               | 4   |
| Module Signal Input Range                       | 0–10 VDC  |
| Signal Resolution                               | 16-bit  |
| Resolution Value of LSB (least significant bit) | 0–10 VDC=152µV, (1LSB = 1 count)                    |
| Data Range                                      | 0-65535 counts unipolar                             |
| Input Type                                      | Single-ended (1 common)                             |
| Maximum Continuous Overload                     | ±100V   |
| Input Impedance                                 | 250kΩ (typical)                                     |
| Filter Characteristics                          | Low Pass, -3dB @ 60Hz                               |
| Sample Duration Time                            | 7ms per channel (Does not include ladder scan time) |
| All Channel Update Rate                         | 50ms  |
| Open Circuit Detection Time                     | Zero reading within 1s                              |
| Conversion Method                               | Successive approximation                            |
| Accuracy vs Temperature                         | ±25PPM / °C maximum                                 |
| Maximum Inaccuracy                              | 0.1% of range (Including temperature drift)         |
| Linearity Error (end to end)                    | ±0.015% of range<br>Monotonic with no missing codes |
| Input Stability and Repeatability               | ±0.015% of range (after 10 min. warm-up)            |
| Full Scale Calibration Error                    | ±0.015% of range maximum                            |
| Offset Calibration Error                        | ±0.015% of range maximum                            |
| Max Crosstalk                                   | -76dB, ±10 LSB                                      |
| External Power Supply Required                  | 24VDC (-20% / + 25%), 35mA                          |

Terminal block sold separately.

We recommend using pre-wired ZIPLink cables and connection modules. See Chapter 5. If you wish to hand-wire your module, removable terminal blocks are sold separately. Order part number P1-10RTB or P1-10RTB-1



## P1-04AD-2 Analog Input (continued)

| General Specifications             |   |
|------------------------------------|---|
| Operating Temperature              | 0°C– 60°C (32°F–140°F)  |
| Storage Temperature                | -20°C–70°C (-4°F–158°F)   |
| Humidity                           | 5 to 95% (non-condensing)   |
| Altitude                           | 2,000 meters, max.  |
| Pollution Degree                   | 2   |
| Environmental Air                  | No corrosive gases permitted  |
| Vibration                          | IEC60068-2-6 (Test Fc)  |
| Shock                              | IEC60068-2-27 (Test Ea)   |
| Field to Logic Side Isolation      | 1800VAC applied for 1s  |
| Insulation Resistance              | >10MΩ @ 500VDC  |
| Heat Dissipation                   | 1400mW  |
| Overvoltage Category               | II  |
| Enclosure Type                     | Open equipment  |
| Module Location                    | Any I/O position in a Productivity1000 System   |
| Field Wiring                       | Removable terminal block (sold separately).<br>Use <b>ZIPLink</b> wiring system optional.<br>See "Wiring Options" in Chapter 5. |
| Terminal Type<br>(sold separately) | 10-position removable terminal block  |
| Weight                             | 58g (2.0 oz)  |
| Agency Approvals                   | UL 61010-1 and UL 61010-2-201 File E139594, Canada and USA<br>CE (EN 61131-2 EMC, EN 61010-1 and EN 61010-2-201 Safety)*        |

| Removable Terminal Block Specifications |   |   |
|---|---|---|
| Part Number                             | P1-10RTB  | P1-10RTB-1  |
| Positions                               | 10 screw terminals  | 10 spring clamp terminals   |
| Wire Range                              | 30–16 AWG (0.051–1.31 mm <sup>2</sup> )<br>Solid/stranded conductor<br>3/64 in. (1.2 mm) insulation max.<br>1/4 in (6– 7 mm) strip length | 28–16 AWG (0.081–1.31 mm <sup>2</sup> )<br>Solid/stranded conductor<br>3/64 in (1.2 mm) insulation max.<br>19/64 in (7–8 mm) strip length |
| Conductors                              | USE COPPER CONDUCTORS, 75°C or equivalent.  |   |
| Screw Driver                            | 0.1 in (2.5 mm) maximum*  |   |
| Screw Size                              | M2  | N/A   |
| Screw Torque                            | 2.5 lb-in (0.28 N·m)  | N/A   |

\* Recommended screw driver P/N: TW-SD-MSL-1.

# P1-04AD-2 Analog Input (continued)

## Wiring Diagrams

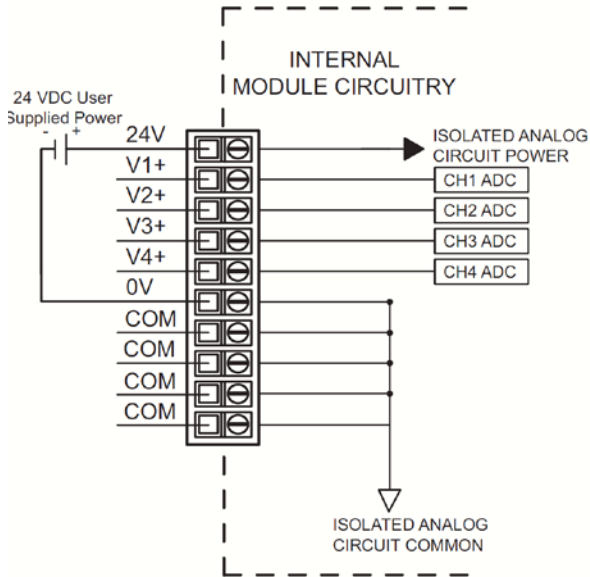

Voltage Input Circuits

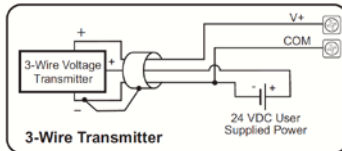
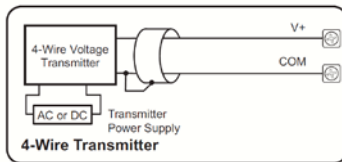

## P1-04AD-2 Analog Input (continued)

### Module Configuration

Using the Hardware Configuration tool in the Productivity Suite programming software, drag and drop the P1-04AD-2 module into the configuration.

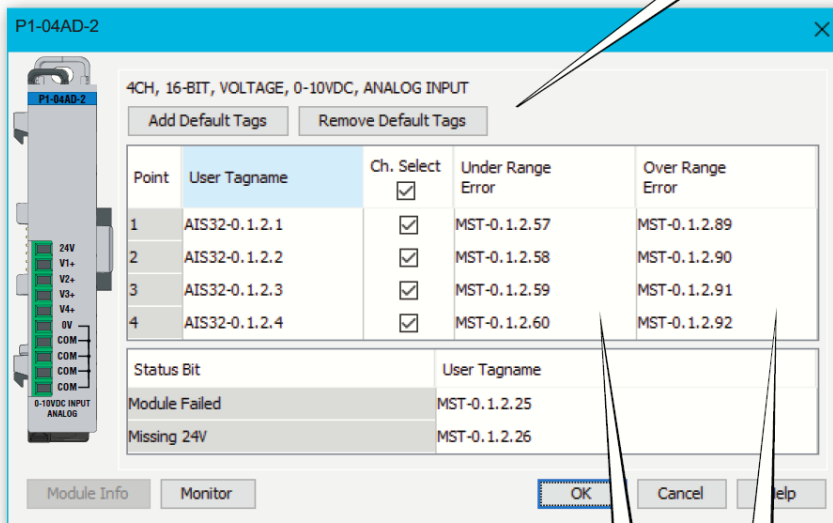

The "Under Range Error" bit for each channel activates for a signal around  $0V \pm$  offset error.  
 The "Over Range Error" bit for each channel activates for a signal around  $10V \pm$  gain error.

# P1-04ADL-1 Analog Input

The P1-04ADL-1 Low Resolution Analog Input Module provides four current sinking channels for converting 0–20 mA analog signals to a digital value of 0–8191 (13-bit) for use with the Productivity®1000 system.

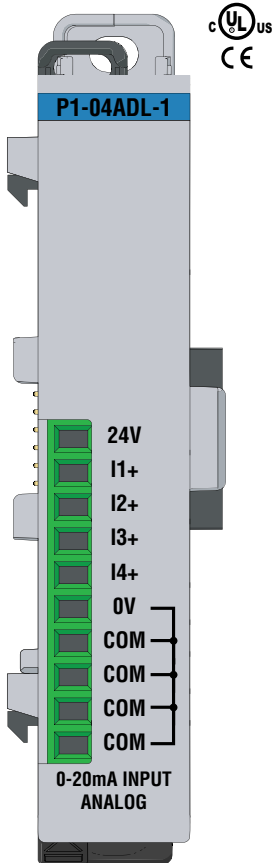

Terminal block sold separately.

| Input Specifications                            |  |
|---|--|
| Input Channels                                  | 4  |
| Input Range                                     | 0–20 mA  |
| Signal Resolution                               | 13-bit   |
| Resolution Value of LSB (least significant bit) | 0–20 mA = 2.44 $\mu$ A per count (1LSB = 1 count)        |
| Data Range                                      | 0–8191 counts  |
| Input Type                                      | Sinking, Single-ended (1 common)                         |
| Maximum Continuous Overload                     | $\pm$ 31mA   |
| Input Impedance                                 | 243 $\Omega$ , $\pm$ 0.5%, 1/4W Current Input            |
| Filter Characteristics                          | Low Pass, -3dB @ 120Hz                                   |
| Sample Duration Time                            | 2.5 ms per channel (Does not include ladder scan time)   |
| All Channel Update Rate                         | 10ms   |
| Open Circuit Detection Time                     | Zero reading within 100ms                                |
| Conversion Method                               | Successive approximation                                 |
| Accuracy vs Temperature                         | $\pm$ 75PPM / $^{\circ}$ C maximum                       |
| Maximum Inaccuracy                              | 0.5% of range (Including temperature drift)              |
| Linearity Error (end to end)                    | $\pm$ 0.037% of range<br>Monotonic with no missing codes |
| Input Stability and Repeatability               | $\pm$ 0.024% of range                                    |
| Maximum Full Scale Calibration Error            | $\pm$ 0.098% of range                                    |
| Offset Calibration Error                        | $\pm$ 0.098% of range                                    |
| Max Crosstalk at DC, 50Hz and 60Hz              | $\pm$ 0.049% of range                                    |
| Recommended Fuse (external)                     | Edison S500-32-R, 0.032 A fuse                           |
| External DC Power Required                      | 24VDC (-20% / + 25%), 30mA                               |

We recommend using pre-wired ZIPLink cables and connection modules. See Chapter 5. If you wish to hand-wire your module, removable terminal blocks are sold separately. Order part number P1-10RTB or P1-10RTB-1



## P1-04ADL-1 Analog Input (continued)

| General Specifications          |  |
|---------------------------------|--|
| Operating Temperature           | 0°C– 60°C (32°F–140°F)   |
| Storage Temperature             | -20°C–70°C (-4°F–158°F)  |
| Humidity                        | 5 to 95% (non-condensing)  |
| Altitude                        | 2,000 meters, max.   |
| Pollution Degree                | 2  |
| Environmental Air               | No corrosive gases permitted   |
| Vibration                       | IEC60068-2-6 (Test Fc)   |
| Shock                           | IEC60068-2-27 (Test Ea)  |
| Field to Logic Side Isolation   | 1800VAC applied for 1s   |
| Insulation Resistance           | >10MΩ @ 500VDC   |
| Heat Dissipation                | 1200mW   |
| Overvoltage Category            | II   |
| Enclosure Type                  | Open equipment   |
| Module Location                 | Any I/O position in a Productivity <sup>®</sup> 1000 system  |
| Field Wiring                    | Use <b>ZIPL</b> ink wiring system or removable terminal block (not included). See "Wiring Options" in Chapter 5.         |
| Terminal Type (sold separately) | 10-position removable terminal block   |
| Weight                          | 71g (2.5 oz)   |
| Agency Approvals                | UL 61010-1 and UL 61010-2-201 File E139594, Canada and USA<br>CE (EN 61131-2 EMC, EN 61010-1 and EN 61010-2-201 Safety)* |

\* See CE Declaration of Conformance for details.

| Removable Terminal Block Specifications |   |   |
|---|---|---|
| Part Number                             | P1-10RTB  | P1-10RTB-1  |
| Number of positions                     | 10 screw terminals  | 10 spring clamp terminals   |
| Wire Range                              | 30–16 AWG (0.051–1.31 mm <sup>2</sup> )<br>Solid/stranded conductor<br>3/64 in. (1.2 mm) insulation max.<br>1/4 in (6– 7 mm) strip length | 28–16 AWG (0.081–1.31 mm <sup>2</sup> )<br>Solid/stranded conductor<br>3/64 in (1.2 mm) insulation max.<br>19/64 in (7–8 mm) strip length |
| Conductors                              | USE COPPER CONDUCTORS, 75°C or equivalent.  |   |
| Screw Driver                            | 0.1 in (2.5 mm) maximum*  |   |
| Screw Size                              | M2  | N/A   |
| Screw Torque                            | 2.5 lb-in (0.28 N·m)  | N/A   |

\* Recommended screw driver P/N: TW-SD-MSL-1.

# P1-04ADL-1 Analog Input (continued)

## Wiring Diagrams

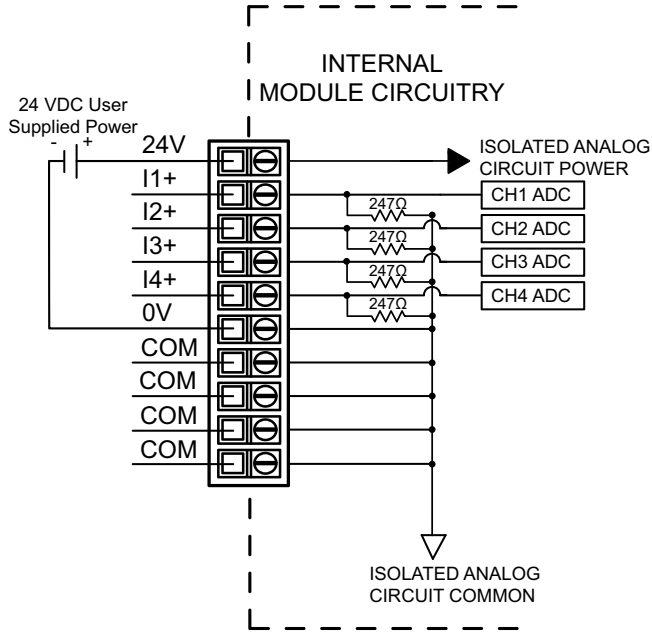

### Current Input Circuits

An Edison S500-32-R 0.032 A fast-acting fuse is recommended for current loops.

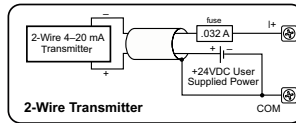

2-Wire Transmitter

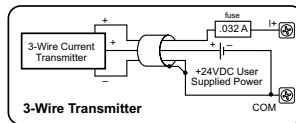

3-Wire Transmitter

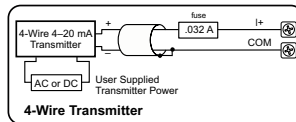

4-Wire Transmitter

Note: Do not connect both ends of shield.

## P1-04ADL-1 Analog Input (continued)

### Module Configuration

Using the Hardware Configuration tool in the Productivity Suite programming software, drag and drop the P1-04ADL-1 module into the configuration.

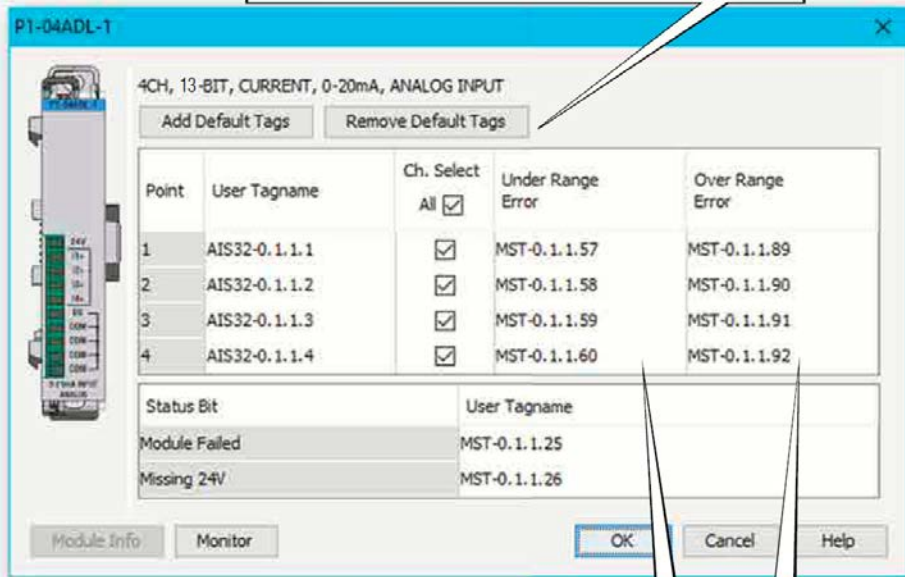

The “Under Range Error” bit for each channel activates for a signal around  $0\text{mA} \pm \text{offset error}$ .  
 The “Over Range Error” bit for each channel activates for a signal around  $19.999\text{ mA} \pm \text{gain error}$ .

# P1-04ADL-2 Analog Input

The P1-04ADL-2 Low Resolution Voltage Analog Input Module provides four channels for converting 0–10 VDC analog signals to digital values of 0–8191 (13-bit) for use with the Productivity®1000 system.

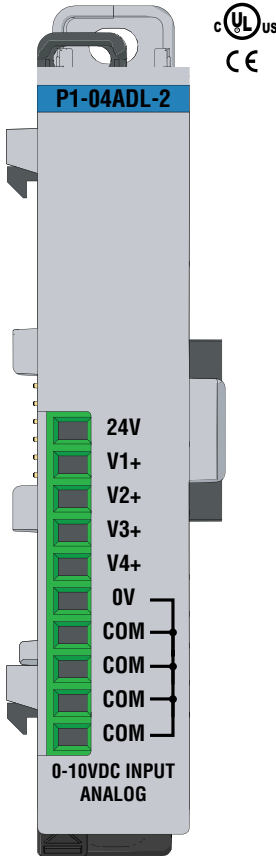

| Input Specifications                            |   |
|---|---|
| Input Channels                                  | 4   |
| Input Range                                     | 0–10 VDC  |
| Signal Resolution                               | 13-bit  |
| Resolution Value of LSB                         | 0–10 VDC = 1.22 mV per count<br>(1 LSB = 1 count)         |
| Data Range                                      | 0–8191 counts   |
| Input Type                                      | Single-ended (1 common)                                   |
| Maximum Continuous Overload                     | ±100VDC   |
| Input Impedance                                 | >150kΩ  |
| Hardware Filter Characteristics                 | Low Pass, -3dB @ 300Hz                                    |
| Sample Duration Time                            | 2.5 ms per channel<br>(does not include ladder scan time) |
| All Channel Update Rate                         | 10ms  |
| Conversion Method                               | Successive approximation                                  |
| Accuracy vs Temperature                         | ±75PPM / °C maximum                                       |
| Maximum Inaccuracy                              | 0.5% of range<br>(including temperature drift)            |
| Linearity Error (end to end)                    | ±0.036% of range<br>Monotonic with no missing codes       |
| Input Stability and Repeatability               | ±0.024% of range  |
| Full Scale Calibration Error (including offset) | ±0.097% of range  |
| Offset Calibration Error                        | ±0.097% of range  |
| Max Crosstalk at DC, 50Hz and 60Hz              | ±0.049% of range  |
| External 24VDC Power Required                   | 24VDC (-20% / +25%), 30mA                                 |

Terminal block sold separately.

We recommend using pre-wired ZIPLink cables and connection modules. See Chapter 5. If you wish to hand-wire your module, removable terminal blocks are sold separately. Order part number P1-10RTB or P1-10RTB-1



| Diagnosis/Status  |                   |
|-------------------|-------------------|
| Under Range Error | 1 bit per channel |
| Over Range Error  | 1 bit per channel |
| Module Failed     | 1 bit per module  |
| Missing 24V       | 1 bit per module  |

## P1-04ADL-2 Analog Input (continued)

| General Specifications          |  |
|---------------------------------|--|
| Operating Temperature           | 0°C–60°C (32°F–140°F)  |
| Storage Temperature             | -20°C–70°C (-4°F–158°F)  |
| Humidity                        | 5 to 95% (non-condensing)  |
| Altitude                        | 2000 meters max.   |
| Pollution Degree                | 2  |
| Environmental Air               | No corrosive gases permitted   |
| Vibration                       | IEC60068-2-6 (Test Fc)   |
| Shock                           | IEC60068-2-27 (Test Ea)  |
| Field to Logic Side Isolation   | 1800VAC applied for 1s   |
| Insulation Resistance           | >10MΩ @ 500VDC   |
| Heat Dissipation                | 1200mW   |
| Overvoltage Category            | II   |
| Enclosure Type                  | Open equipment   |
| Module Location                 | Any I/O position in a Productivity®1000 system   |
| Field Wiring                    | Use ZIPLink wiring system or removable terminal block (not included). See "Wiring Options" in Chapter 5.                 |
| Terminal Type (sold separately) | 10-position removable terminal block   |
| Weight                          | 62g (2.2 oz)   |
| Agency Approvals                | UL 61010-1 and UL 61010-2-201 File E139594, Canada and USA<br>CE (EN 61131-2 EMC, EN 61010-1 and EN 61010-2-201 Safety)* |

\* See CE Declaration of Conformance for details.

| Removable Terminal Block Specifications |  |   |
|---|--|---|
| Part Number                             | P1-10RTB   | P1-10RTB-1  |
| Number of positions                     | 10 screw terminals   | 10 spring clamp terminals   |
| Wire Range                              | 30–16 AWG (0.051–1.31 mm <sup>2</sup> )<br>Solid/stranded conductor<br>3/64 in. (1.2 mm) insulation max.<br>1/4 in (6–7 mm) strip length | 28–16 AWG (0.081–1.31 mm <sup>2</sup> )<br>Solid/stranded conductor<br>3/64 in (1.2 mm) insulation max.<br>19/64 in (7–8 mm) strip length |
| Conductors                              | USE COPPER CONDUCTORS, 75°C or equivalent.   |   |
| Screw Driver                            | 0.1 in (2.5 mm) maximum*   |   |
| Screw Size                              | M2   | N/A   |
| Screw Torque                            | 2.5 lb-in (0.28 N-m)   | N/A   |

\* Recommended screw driver P/N: TW-SD-SL-1 or TW-SD-MSL-1

# P1-04ADL-2 Analog Input (continued)

## Wiring Diagrams

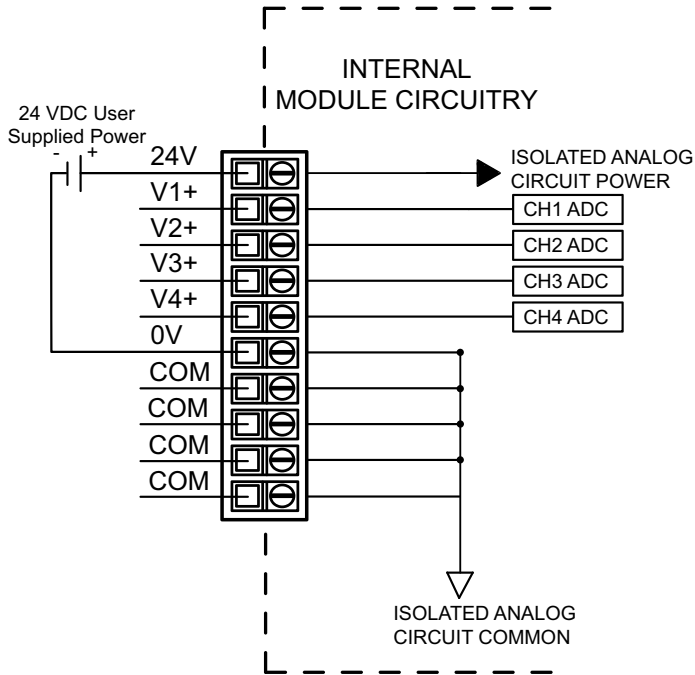

### Voltage Input Circuits

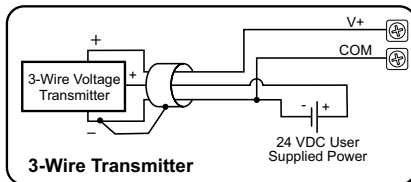
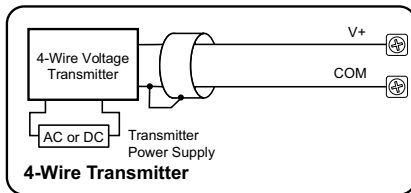

Notes for maximum accuracy:  
1. Jumper unused inputs to common.



## P1-04ADL-2 Analog Input (continued)

### Module Configuration

Using the Hardware Configuration tool in the Productivity Suite programming software, drag and drop the P1-04ADL-2 module into the configuration.

If desired, assign a *User Tagname* to each input point (channel) selected and to each *Status Bit Item*.

P1-04ADL-2

4CH, 13-BIT, VOLTAGE, 0-10VDC, ANALOG INPUT

Add Default Tags Remove Default Tags

| Point | User Tagname  | Ch. Select                              | Under Range Error | Over Range Error |
|-------|---------------|---|-------------------|------------------|
|       |               | All <input checked="" type="checkbox"/> |                   |                  |
| 1     | AIS32-0.1.1.1 | <input checked="" type="checkbox"/>     | MST-0.1.1.57      | MST-0.1.1.89     |
| 2     | AIS32-0.1.1.2 | <input checked="" type="checkbox"/>     | MST-0.1.1.58      | MST-0.1.1.90     |
| 3     | AIS32-0.1.1.3 | <input checked="" type="checkbox"/>     | MST-0.1.1.59      | MST-0.1.1.91     |
| 4     | AIS32-0.1.1.4 | <input checked="" type="checkbox"/>     | MST-0.1.1.60      | MST-0.1.1.92     |

| Status Bit    | User Tagname |
|---------------|--------------|
| Module Failed | MST-0.1.1.25 |
| Missing 24V   | MST-0.1.1.26 |

Module Info Monitor Ok Cancel Help

The “Under Range Error” bit for each channel activates for a signal around 0V,  $\pm$  offset error.

The “Over Range Error” bit for each channel activates for a signal around 10V,  $\pm$  gain error.

# P1-08ADL-1 Analog Input

The P1-08ADL-1 Low Resolution Analog Input Module provides eight current sinking channels for converting 0–20 mA analog signals to a digital value of 0–8191 (13-bit) for use with the Productivity®1000 system.

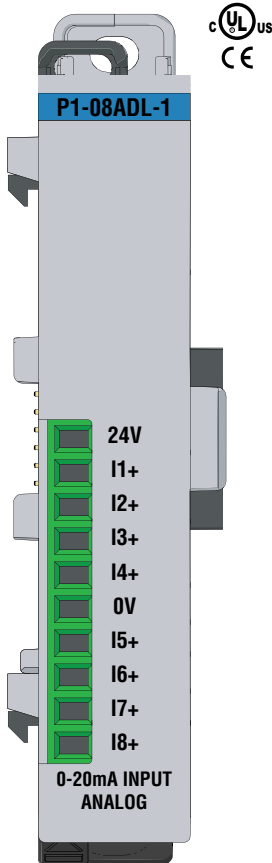

Terminal block sold separately.

| Input Specifications                            |  |
|---|--|
| Input Channels                                  | 8  |
| Input Range                                     | 0–20 mA  |
| Signal Resolution                               | 13-bit   |
| Resolution Value of LSB (least significant bit) | 0–20 mA = 2.44 $\mu$ A per count (1LSB = 1 count)        |
| Data Range                                      | 0–8191 counts  |
| Input Type                                      | Sinking, Single-ended (1 common)                         |
| Maximum Continuous Overload                     | $\pm$ 31mA   |
| Input Impedance                                 | 243 $\Omega$ , $\pm$ 1%, 1/8W Current Input              |
| Filter Characteristics                          | Low Pass, -3dB @ 120Hz                                   |
| Sample Duration Time                            | 2ms per channel (Does not include ladder scan time)      |
| All Channel Update Rate                         | 20ms   |
| Open Circuit Detection Time                     | Zero reading within 100ms                                |
| Conversion Method                               | Successive approximation                                 |
| Accuracy vs Temperature                         | $\pm$ 75PPM / $^{\circ}$ C maximum                       |
| Maximum Inaccuracy                              | 0.5% of range (Including temperature drift)              |
| Linearity Error (end to end)                    | $\pm$ 0.037% of range<br>Monotonic with no missing codes |
| Input Stability and Repeatability               | $\pm$ 0.024% of range                                    |
| Maximum Full Scale Calibration Error            | $\pm$ 0.098% of range                                    |
| Offset Calibration Error                        | $\pm$ 0.098% of range                                    |
| Max Crosstalk at DC, 50Hz and 60Hz              | $\pm$ 0.049% of range                                    |
| Recommended External Fuse                       | Edison S500-32-R, 0.032 A fuse                           |
| External DC Power Required                      | 24VDC (-20% / + 25%), 30mA                               |

We recommend using pre-wired ZIPLink cables and connection modules. See Chapter 5. If you wish to hand-wire your module, removable terminal blocks are sold separately. Order part number P1-10RTB or P1-10RTB-1



## P1-08ADL-1 Analog Input (continued)

| General Specifications          |  |
|---------------------------------|--|
| Operating Temperature           | 0°C– 60°C (32°F–140°F)   |
| Storage Temperature             | -20°C–70°C (-4°F–158°F)  |
| Humidity                        | 5 to 95% (non-condensing)  |
| Environmental Air               | No corrosive gases permitted   |
| Vibration                       | IEC60068-2-6 (Test Fc)   |
| Shock                           | IEC60068-2-27 (Test Ea)  |
| Field to Logic Side Isolation   | 1800VAC applied for 1s   |
| Insulation Resistance           | >10MΩ @ 500VDC   |
| Heat Dissipation                | 1200mW   |
| Enclosure Type                  | Open equipment   |
| Module Location                 | Any I/O position in a Productivity@1000 system   |
| Field Wiring                    | Use ZIPLink wiring system or removable terminal block (not included). See "Wiring Options" in Chapter 5.                 |
| Terminal Type (sold separately) | 10-position removable terminal block   |
| Weight                          | 71g (2.5 oz)   |
| Agency Approvals                | UL 61010-1 and UL 61010-2-201 File E139594, Canada and USA<br>CE (EN 61131-2 EMC, EN 61010-1 and EN 61010-2-201 Safety)* |

\* See CE Declaration of Conformance for details.

| Removable Terminal Block Specifications |   |   |
|---|---|---|
| Part Number                             | P1-10RTB  | P1-10RTB-1  |
| Number of positions                     | 10 screw terminals  | 10 spring clamp terminals   |
| Wire Range                              | 30–16 AWG (0.051–1.31 mm <sup>2</sup> )<br>Solid/stranded conductor<br>3/64 in. (1.2 mm) insulation max.<br>1/4 in (6– 7 mm) strip length | 28–16 AWG (0.081–1.31 mm <sup>2</sup> )<br>Solid/stranded conductor<br>3/64 in (1.2 mm) insulation max.<br>19/64 in (7–8 mm) strip length |
| Conductors                              | USE COPPER CONDUCTORS, 75°C or equivalent.  |   |
| Screw Driver                            | 0.1 in (2.5 mm) maximum*  |   |
| Screw Size                              | M2  | N/A   |
| Screw Torque                            | 2.5 lb-in (0.28 N-m)  | N/A   |

\* Recommended screw driver P/N: TW-SD-MSL-1.

# P1-08ADL-1 Analog Input (continued)

## Wiring Diagrams

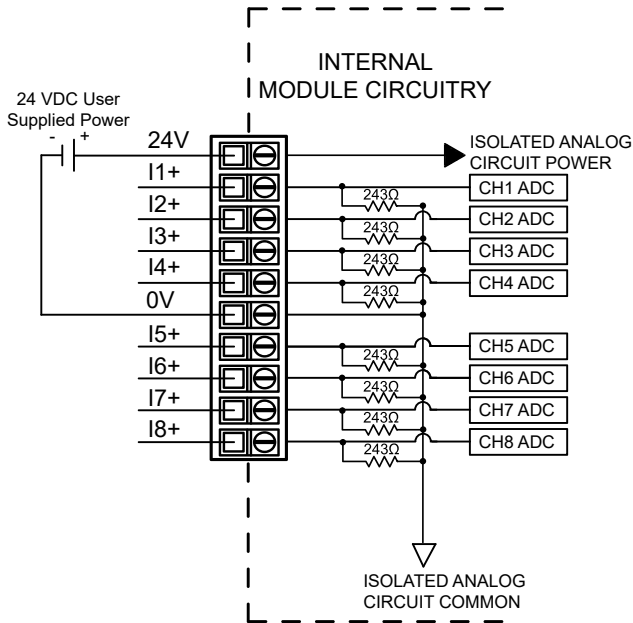

### Current Input Circuits

An Edison S500-32-R 0.032A fast-acting fuse is recommended for current loops.

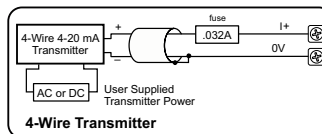
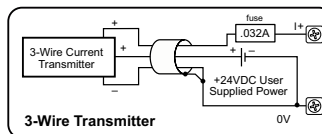
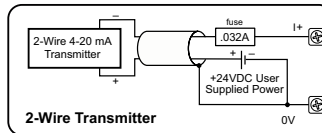

Note: Do not connect both ends of shield.

# P1-08ADL-1 Analog Input (continued)

## Module Configuration

Using the Hardware Configuration tool in the Productivity Suite programming software, drag and drop the P1-08ADL-1 module into the base configuration.

Select *Automatic Module Verification* or *No Verification and Enable Hot Swap*. If desired, assign a *User Tagname* to each output point channel selected and to each *Status Bit Item*. A *Stop Mode Value* may also be assigned.

8CH, 13-BIT, CURRENT, ANALOG INPUT

Automatic Module Verification  
 No Verification and Enable Hot Swap

| Point | User Tagname   | Ch Select                           | Under Range Error | Over Range Error |
|-------|----------------|-------------------------------------|-------------------|------------------|
| 1     | AIS32-0.1.10.1 | <input checked="" type="checkbox"/> | MST-0.1.10.57     | MST-0.1.10.89    |
| 2     | AIS32-0.1.10.2 | <input checked="" type="checkbox"/> | MST-0.1.10.58     | MST-0.1.10.90    |
| 3     | AIS32-0.1.10.3 | <input checked="" type="checkbox"/> | MST-0.1.10.59     | MST-0.1.10.91    |
| 4     | AIS32-0.1.10.4 | <input checked="" type="checkbox"/> | MST-0.1.10.60     | MST-0.1.10.92    |
| 5     | AIS32-0.1.10.5 | <input checked="" type="checkbox"/> | MST-0.1.10.61     | MST-0.1.10.93    |
| 6     | AIS32-0.1.10.6 | <input checked="" type="checkbox"/> | MST-0.1.10.62     | MST-0.1.10.94    |
| 7     | AIS32-0.1.10.7 | <input checked="" type="checkbox"/> | MST-0.1.10.63     | MST-0.1.10.95    |
| 8     | AIS32-0.1.10.8 | <input checked="" type="checkbox"/> | MST-0.1.10.64     | MST-0.1.10.96    |

| Status Bit    | User Tagname  |
|---------------|---------------|
| Module Failed | MST-0.1.10.21 |
| Missing 24V   | MST-0.1.10.26 |

The 'Under Range Error' bit for each channel activates below 0mA.  
 The 'Over Range Error' bit for each channel activates at a count of 8190 and above (above 19.999 mA).

# P1-08ADL-2 Analog Input

The P1-08ADL-2 Low Resolution Voltage Analog Input Module provides eight channels for converting 0–10 VDC analog signals to digital values of 0–8191 (13-bit) for use with the Productivity®1000 system.

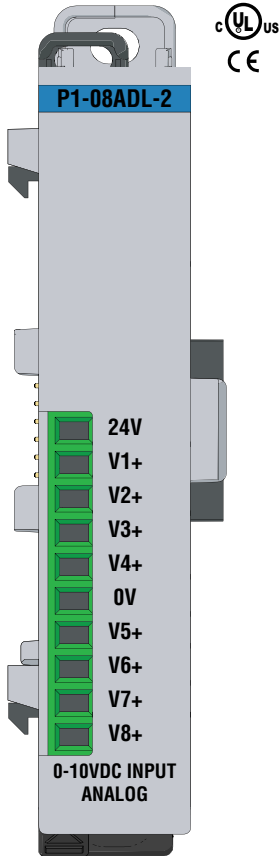

| Input Specifications                            |  |
|---|--|
| Input Channels                                  | 8  |
| Input Range                                     | 0–10 VDC   |
| Signal Resolution                               | 13-bit   |
| Resolution Value of LSB                         | 0–10 VDC = 1.22 mV per count (1 LSB = 1 count)         |
| Data Range                                      | 0–8191 counts  |
| Input Type                                      | Single-ended (1 common)                                |
| Maximum Continuous Overload                     | ±100VDC  |
| Input Impedance                                 | >150kΩ   |
| Hardware Filter Characteristics                 | Low Pass, -3dB @ 500Hz                                 |
| Sample Duration Time                            | 2.5 ms per channel (Does not include ladder scan time) |
| All Channel Update Rate                         | 25ms   |
| Conversion Method                               | Successive approximation                               |
| Accuracy vs Temperature                         | ±75PPM / °C maximum                                    |
| Maximum Inaccuracy                              | 0.5% of range (Including temperature drift)            |
| Linearity Error                                 | ±0.036% of range Monotonic with no missing codes       |
| Input Stability and Repeatability               | ±0.024% of range                                       |
| Full Scale Calibration Error (including offset) | ±0.097% of range                                       |
| Offset Calibration Error                        | ±0.097% of range                                       |
| Max Crosstalk at DC, 50Hz and 60Hz              | ±0.049% of range                                       |
| External 24VDC Power Required                   | 24VDC (-20% / +25%), 30mA                              |

Terminal block sold separately.

We recommend using pre-wired ZIPLink cables and connection modules. See Chapter 5. If you wish to hand-wire your module, removable terminal blocks are sold separately. Order part number P1-10RTB or P1-10RTB-1



| Diagnosis/Status  |                   |
|-------------------|-------------------|
| Under Range Error | 1 bit per channel |
| Over Range Error  | 1 bit per channel |
| Module Failed     | 1 bit per module  |
| Missing 24V       | 1 bit per module  |

## P1-08ADL-2 Analog Input (continued)

| General Specifications          |  |
|---------------------------------|--|
| Operating Temperature           | 0°C– 60°C (32°F–140°F)   |
| Storage Temperature             | -20°C–70°C (-4°F–158°F)  |
| Humidity                        | 5 to 95% (non-condensing)  |
| Altitude                        | 2000 meters max.   |
| Pollution Degree                | 2  |
| Environmental Air               | No corrosive gases permitted   |
| Vibration                       | IEC60068-2-6 (Test Fc)   |
| Shock                           | IEC60068-2-27 (Test Ea)  |
| Field to Logic Side Isolation   | 1800VAC applied for 1s   |
| Insulation Resistance           | >10MΩ @ 500VDC   |
| Heat Dissipation                | 1200mW   |
| Overvoltage Category            | II   |
| Enclosure Type                  | Open equipment   |
| Module Location                 | Any I/O position in a Productivity@1000 system   |
| Field Wiring                    | Use ZIPLink wiring system or removable terminal block (not included). See "Wiring Options" in Chapter 5..                |
| Terminal Type (sold separately) | 10-position removable terminal block   |
| Weight                          | 71g (2.5 oz)   |
| Agency Approvals                | UL 61010-1 and UL 61010-2-201 File E139594, Canada and USA<br>CE (EN 61131-2 EMC, EN 61010-1 and EN 61010-2-201 Safety)* |

\* See CE Declaration of Conformance for details.

| Removable Terminal Block Specifications |   |   |
|---|---|---|
| Part Number                             | P1-10RTB  | P1-10RTB-1  |
| Number of positions                     | 10 screw terminals  | 10 spring clamp terminals   |
| Wire Range                              | 30–16 AWG (0.051–1.31 mm <sup>2</sup> )<br>Solid/stranded conductor<br>3/64 in. (1.2 mm) insulation max.<br>1/4 in (6– 7 mm) strip length | 28–16 AWG (0.081–1.31 mm <sup>2</sup> )<br>Solid/stranded conductor<br>3/64 in (1.2 mm) insulation max.<br>19/64 in (7–8 mm) strip length |
| Conductors                              | USE COPPER CONDUCTORS, 75°C or equivalent.  |   |
| Screw Driver                            | 0.1 in (2.5 mm) maximum*  |   |
| Screw Size                              | M2  | N/A   |
| Screw Torque                            | 2.5 lb·in (0.28 N·m)  | N/A   |

\* Recommended screw driver P/N: TW-SD-MSL-1.

# P1-08ADL-2 Analog Input (continued)

## Wiring Diagrams

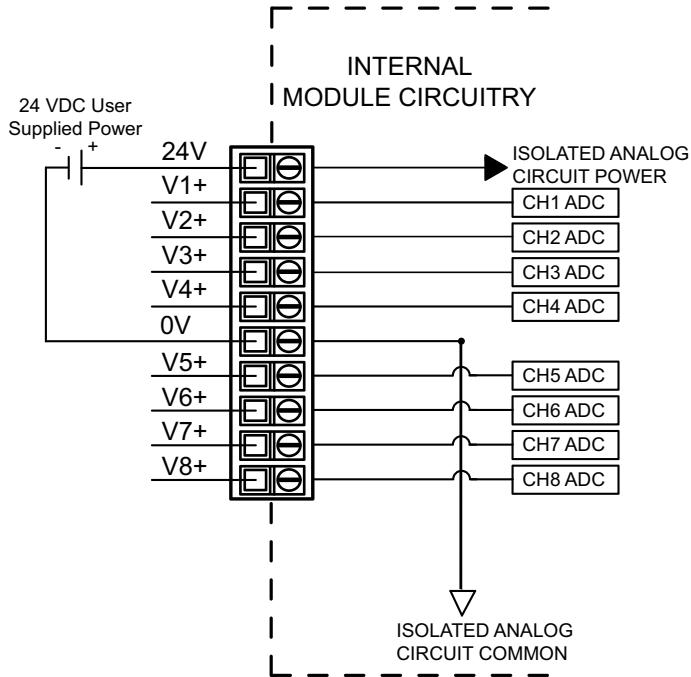

### Voltage Input Circuits

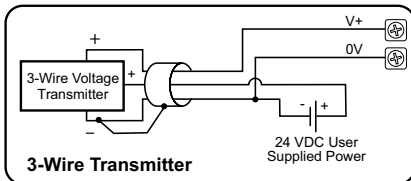
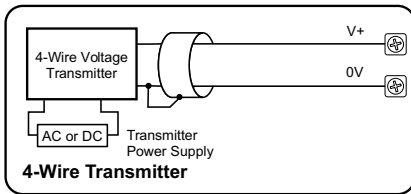

Notes for maximum accuracy:  
1. Jumper unused inputs to common.

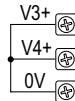

Note: Do not connect both ends of shield.

## P1-08ADL-2 Analog Input (continued)

### Module Configuration

Using the Hardware Configuration tool in the Productivity Suite programming software, drag and drop the P1-08ADL-2 module into the base configuration.

If desired, assign a *User Tagname* to each input point (channel) selected and to each *Status Bit Item*. A *Stop Mode Value* may be assigned.

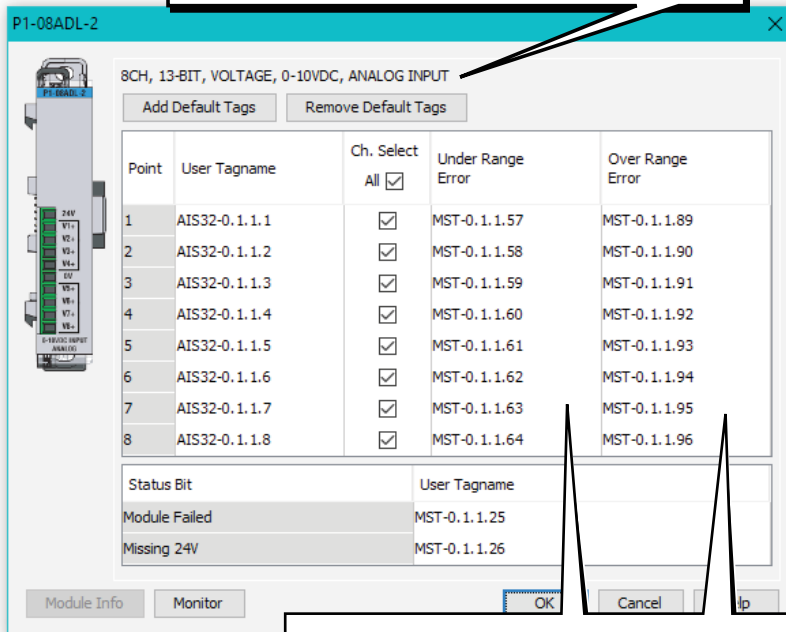

The “Under Range Error” bit for each channel activates for a signal around 0V,  $\pm$  offset error.

The “Over Range Error” bit for each channel activates for a signal around 10V,  $\pm$  gain error.

## P1-04RTD Analog Input

The P1-04RTD Input Module provides four differential channels for receiving RTD and resistance input signals for use with the Productivity@1000 system.

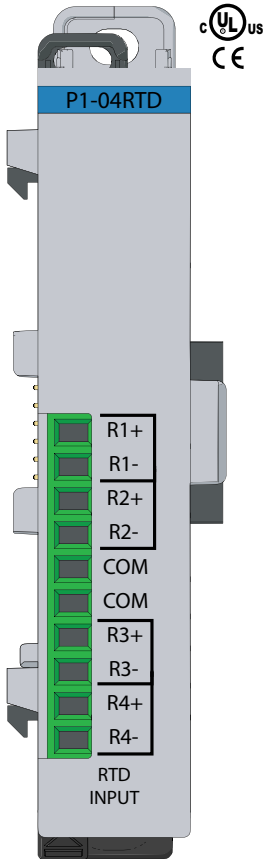

**Terminal Block Included.  
Not Compatible with ZIPLink.**

| RTD Input Specifications                     |   |       |   |        |   |        |  |                 |  |                 |  |                  |   |
|--|---|-------|---|--------|---|--------|--|-----------------|--|-----------------|--|------------------|---|
| Input Channels                               | 4 Differential  |       |   |        |   |        |  |                 |  |                 |  |                  |   |
| Data Format                                  | Floating Point  |       |   |        |   |        |  |                 |  |                 |  |                  |   |
| Max. Common Mode Voltage                     | 5VDC  |       |   |        |   |        |  |                 |  |                 |  |                  |   |
| Common Mode Rejection                        | -100dB min. @ DC, -100dB min. @ 50/60 Hz*   |       |   |        |   |        |  |                 |  |                 |  |                  |   |
| Absolute Maximum Ratings                     | Fault protected input, $\pm 50V$  |       |   |        |   |        |  |                 |  |                 |  |                  |   |
| Internal Resolution                          | 16-bit, $\pm 0.1^{\circ}C$ or $^{\circ}F$   |       |   |        |   |        |  |                 |  |                 |  |                  |   |
| Input Ranges (RTD Types)                     | <table border="1"> <tr> <td>Pt100</td> <td>-200<math>^{\circ}C</math>–850<math>^{\circ}C</math> (-328<math>^{\circ}F</math>–1562<math>^{\circ}F</math>)</td> </tr> <tr> <td>Pt1000</td> <td>-200<math>^{\circ}C</math>–595<math>^{\circ}C</math> (-328<math>^{\circ}F</math>–1103<math>^{\circ}F</math>)</td> </tr> <tr> <td>JPt100</td> <td>-100<math>^{\circ}C</math>–450<math>^{\circ}C</math> (-148<math>^{\circ}F</math>–842<math>^{\circ}F</math>)</td> </tr> <tr> <td>10<math>\Omega</math> Cu.</td> <td>-200<math>^{\circ}C</math>–260<math>^{\circ}C</math> (-328<math>^{\circ}F</math>–500<math>^{\circ}F</math>)</td> </tr> <tr> <td>25<math>\Omega</math> Cu.</td> <td>-200<math>^{\circ}C</math>–260<math>^{\circ}C</math> (-328<math>^{\circ}F</math>–500<math>^{\circ}F</math>)</td> </tr> <tr> <td>120<math>\Omega</math> Ni.</td> <td>-80<math>^{\circ}C</math>–260<math>^{\circ}C</math> (-112<math>^{\circ}F</math>–500<math>^{\circ}F</math>)</td> </tr> </table> | Pt100 | -200 $^{\circ}C$ –850 $^{\circ}C$ (-328 $^{\circ}F$ –1562 $^{\circ}F$ ) | Pt1000 | -200 $^{\circ}C$ –595 $^{\circ}C$ (-328 $^{\circ}F$ –1103 $^{\circ}F$ ) | JPt100 | -100 $^{\circ}C$ –450 $^{\circ}C$ (-148 $^{\circ}F$ –842 $^{\circ}F$ ) | 10 $\Omega$ Cu. | -200 $^{\circ}C$ –260 $^{\circ}C$ (-328 $^{\circ}F$ –500 $^{\circ}F$ ) | 25 $\Omega$ Cu. | -200 $^{\circ}C$ –260 $^{\circ}C$ (-328 $^{\circ}F$ –500 $^{\circ}F$ ) | 120 $\Omega$ Ni. | -80 $^{\circ}C$ –260 $^{\circ}C$ (-112 $^{\circ}F$ –500 $^{\circ}F$ ) |
| Pt100  | -200 $^{\circ}C$ –850 $^{\circ}C$ (-328 $^{\circ}F$ –1562 $^{\circ}F$ )   |       |   |        |   |        |  |                 |  |                 |  |                  |   |
| Pt1000                                       | -200 $^{\circ}C$ –595 $^{\circ}C$ (-328 $^{\circ}F$ –1103 $^{\circ}F$ )   |       |   |        |   |        |  |                 |  |                 |  |                  |   |
| JPt100                                       | -100 $^{\circ}C$ –450 $^{\circ}C$ (-148 $^{\circ}F$ –842 $^{\circ}F$ )  |       |   |        |   |        |  |                 |  |                 |  |                  |   |
| 10 $\Omega$ Cu.                              | -200 $^{\circ}C$ –260 $^{\circ}C$ (-328 $^{\circ}F$ –500 $^{\circ}F$ )  |       |   |        |   |        |  |                 |  |                 |  |                  |   |
| 25 $\Omega$ Cu.                              | -200 $^{\circ}C$ –260 $^{\circ}C$ (-328 $^{\circ}F$ –500 $^{\circ}F$ )  |       |   |        |   |        |  |                 |  |                 |  |                  |   |
| 120 $\Omega$ Ni.                             | -80 $^{\circ}C$ –260 $^{\circ}C$ (-112 $^{\circ}F$ –500 $^{\circ}F$ )   |       |   |        |   |        |  |                 |  |                 |  |                  |   |
| RTD Linearization                            | Automatic   |       |   |        |   |        |  |                 |  |                 |  |                  |   |
| Excitation Current (all ranges)              | 210 $\mu A$   |       |   |        |   |        |  |                 |  |                 |  |                  |   |
| Accuracy vs. Temperature                     | $\pm 10ppm$ per $^{\circ}C$ (maximum)   |       |   |        |   |        |  |                 |  |                 |  |                  |   |
| Warm-up Time                                 | 2 minutes for $\pm 0.2\%$ repeatability   |       |   |        |   |        |  |                 |  |                 |  |                  |   |
| Maximum Inaccuracy*                          | $\pm 1^{\circ}C$ maximum @ 16.7 Hz,<br>$\pm 3^{\circ}C$ maximum @ 470Hz<br>$\pm 5^{\circ}C$ maximum on Cu10 & Cu25  |       |   |        |   |        |  |                 |  |                 |  |                  |   |
| Sample Duration (Single channel update rate) | Dependent on digital filter settings –<br>200ms @ 16.7 Hz, 90ms @ 470Hz   |       |   |        |   |        |  |                 |  |                 |  |                  |   |
| Filter Characteristics                       | Digital filter cutoff frequencies:<br>16.7 Hz, 470Hz  |       |   |        |   |        |  |                 |  |                 |  |                  |   |
| All Channel Update Rate                      | Single channel update rate times the number of enabled channels   |       |   |        |   |        |  |                 |  |                 |  |                  |   |
| Open Circuit Detection Time                  | Burnout detect within 2s  |       |   |        |   |        |  |                 |  |                 |  |                  |   |
| Conversion Method                            | Sigma-Delta   |       |   |        |   |        |  |                 |  |                 |  |                  |   |
| External DC Power Required                   | None  |       |   |        |   |        |  |                 |  |                 |  |                  |   |

\* Note: Excluding RTD error, including temperature drift.

Warranty: Thirty-day money-back guarantee. Two-year limited replacement. (See [www.productivity1000.com](http://www.productivity1000.com) for details).

## P1-04RTD Analog Input (continued)

| General Specifications        |  |
|-------------------------------|--|
| Operating Temperature         | 0°C– 60°C (32°F–140°F)   |
| Storage Temperature           | -20°C–70°C (-4°F–158°F)  |
| Humidity                      | 5 to 95% (non-condensing)  |
| Environmental Air             | No corrosive gases permitted   |
| Vibration                     | IEC60068-2-6 (Test Fc)   |
| Shock                         | IEC60068-2-27 (Test Ea)  |
| Field to Logic Side Isolation | 1800VAC applied for 1s   |
| Heat Dissipation              | 100mW  |
| Enclosure Type                | Open equipment   |
| Module Location               | Any I/O position in a Productivity®1000 system   |
| Field Wiring                  | Removable terminal block (included). The P1-04RTD module is not compatible with the ZIPLink wiring system. |
| Connector Type (included)     | 10-position removable terminal block   |
| Weight                        | 60g (2.1 oz)   |
| Agency Approvals              | UL61010-2-201 File E139594, Canada & USA<br>CE (EN61131-2 EMC and EN61010-2-201 Safety)*                   |

\* See the Declaration of Conformance for details.

| Removable Terminal Block Specifications |   |   |
|---|---|---|
| Part Number                             | P1-10RTB  | P1-10RTB-1  |
| Number of positions                     | 10 screw terminals  | 10 spring clamp terminals   |
| Wire Range                              | 30–16 AWG (0.051–1.31 mm <sup>2</sup> )<br>Solid/stranded conductor<br>3/64 in. (1.2 mm) insulation max.<br>1/4 in (6– 7 mm) strip length | 28–16 AWG (0.081–1.31 mm <sup>2</sup> )<br>Solid/stranded conductor<br>3/64 in (1.2 mm) insulation max.<br>19/64 in (7–8 mm) strip length |
| Conductors                              | USE COPPER CONDUCTORS, 75°C or equivalent.  |   |
| Screw Driver                            | 0.1 in (2.5 mm) maximum*  |   |
| Screw Size                              | M2  | N/A   |
| Screw Torque                            | 2.5 lb-in (0.28 N·m)  | N/A   |

\* Recommended screw driver P/N: TW-SD-MSL-1.

## P1-04RTD Analog Input (continued)

| Resistance Input Specifications            |   |
|--|---|
| Internal Resolution                        | 16 bit, 0.0015% of full scale range in ohms   |
| Resistance Input Ranges and CPU Resolution | 0–10,000 V, Resolution 1V<br>0–6,250 V, Resolution 0.1 V<br>0–3,125 V, Resolution 0.1 V<br>0–1,562.5 V, Resolution 0.1 V<br>0–781.25 V, Resolution 0.1 V<br>0–390.625 V, Resolution 0.01 V<br>0–195.3125 V, Resolution 0.01 V |
| Accuracy vs. Temperature                   | ±25ppm per °C (maximum)   |
| Linearity Error (end to end)               | ± 0.03% @16.7 Hz, ±0.06% 470Hz of full scale range maximum at 25°C, Monotonic with no missing codes   |
| Maximum Inaccuracy                         | ± 0.10% of full scale range   |

| Diagnostics                 |                   |
|-----------------------------|-------------------|
| Module Diagnostics Failure  | 1 bit per module  |
| Module Not Ready            | 1 bit per module  |
| Channel Burn-out (RTD only) | 1 bit per channel |
| Under-range (RTD only)      | 1 bit per channel |
| Over-range                  | 1 bit per channel |

# P1-04RTD Analog Input (continued)

## Wiring Diagrams

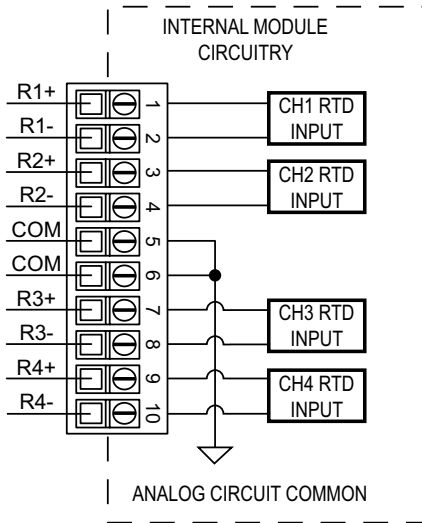

Resistance Input

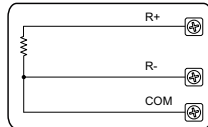

1. R+, R-, and COM wires to an RTD must be equal length and type. Refer to RTD manufacturers

RTD Input Circuits

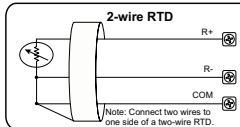

2. For 2-wire RTD, attach a third wire to module common.

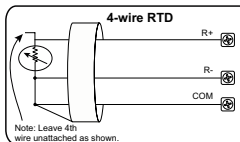
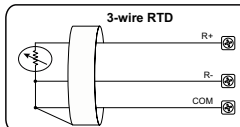

Notes for maximum accuracy:

3. Do not use cable shield as a sensing wire.
4. When applicable, connect shield to RTD common only, otherwise connect to module common only. Do not connect shield to both ends.
5. Jumper unused inputs to common.



# P1-04RTD Analog Input (continued)

## Module Configuration

Using the Hardware Configuration tool in the Productivity Suite programming software, drag and drop the P1-04RTD module into the base configuration.  
 Specify *Temperature Scale* and *Burnout Detection*, and use the drop down menu to select module range and resolution. If desired, assign a *User Tagname* to each output point channel selected and to each *Status Bit*.

4CH, 16-BIT, RTD TEMPERATURE INPUT

Input Range: Pt100    Temperature Scale: Degrees F

Digital Filter: 61 msec    Burnout Detection: Low Side Burnout Detection

Add Default Tags    Remove Default Tags

| Point | User Tagname  | Ch. Select                          | Burnout Error | Under Range Error | Over Range Error |
|-------|---------------|-------------------------------------|---------------|-------------------|------------------|
| 1     | AIF32-0.1.1.1 | <input checked="" type="checkbox"/> | MST-0.1.1.41  | MST-0.1.1.87      | MST-0.1.1.89     |
| 2     | AIF32-0.1.1.2 | <input checked="" type="checkbox"/> | MST-0.1.1.42  | MST-0.1.1.88      | MST-0.1.1.90     |
| 3     | AIF32-0.1.1.3 | <input checked="" type="checkbox"/> | MST-0.1.1.43  | MST-0.1.1.89      | MST-0.1.1.91     |
| 4     | AIF32-0.1.1.4 | <input checked="" type="checkbox"/> | MST-0.1.1.44  | MST-0.1.1.90      | MST-0.1.1.92     |

Status Bit    User Tagname

Module Failed    MST-0.1.1.25

Module Not Ready    MST-0.1.1.27

Module Info    Monitor    OK    Cancel    Help

# P1-04THMS Analog Input

The P1-04THMS Thermocouple Input Module provides four differential channels (two isolated channels) for receiving thermocouple and voltage input signals for use with the Productivity1000 system.

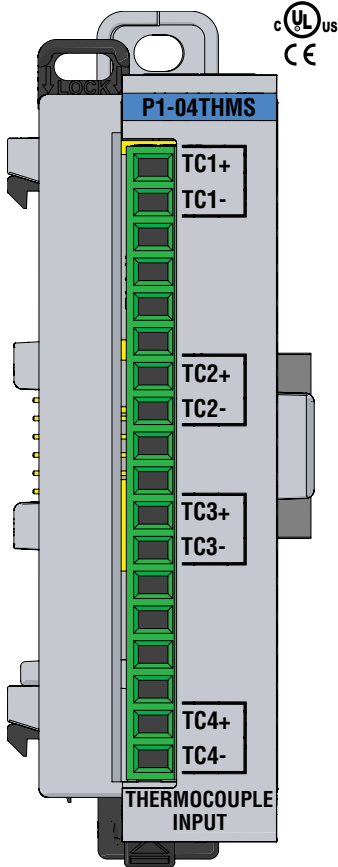

**Terminal Block Included.**  
**Not Compatible with Z/IPLink.**

## Thermocouple Input Specifications

|                                |   |
|--------------------------------|---|
| Input Channels                 | 4 differential channels (2 isolated pairs)  |
| Data Format                    | Floating Point  |
| Common Mode Range              | ±1.25 V   |
| Common Mode Rejection          | 100 dB @ DC   |
| Input Impedance                | >5 MΩ   |
| Maximum Ratings                | Fault protected inputs to ±50V  |
| Resolution                     | 16-bit, ±0.1°C or °F  |
| Thermocouple Input Ranges      | Type J -190 to 760 °C (-310 to +1400 °F);<br>Type E -210 to 1000 °C (-346 to +1832°F);<br>Type K -150 to 1372 °C (-238 to +2502 °F);<br>Type R 65 to 1768 °C (149 to 3214 °F);<br>Type S 65 to 1768 °C (149 to 3214 °F);<br>Type T -230 to 400 °C (-382 to +752 °F);<br>Type B 529 to 1820 °C (984 to 3308 °F);<br>Type N -70 to 1300 °C (-94 to +2372 °F);<br>Type C 65 to 2320 °C (149 to 4208 °F); |
| Thermocouple Linearization     | Automatic   |
| Cold Junction Compensation     | Automatic   |
| Sample Duration Time           | 270 ms  |
| All Channel Update Rate        | 1.08 s  |
| Open Circuit Detection Time    | Within 5 s  |
| Conversion Method              | Sigma-Delta   |
| Accuracy vs. Temperature       | ±50 ppm per °C (maximum)  |
| Maximum Inaccuracy             | ±3 °C maximum<br>(excluding thermocouple error).  |
| Linearity Error                | ±1 °C maximum (±0.5 °C typical)<br>Monotonic with no missing codes.   |
| Warm-up Time                   | 30 minutes for ±1% repeatability<br>2 minutes to reach voltage specifications   |
| External Power Supply Required | None  |

## Voltage Input Specifications

|                                   |  |
|-----------------------------------|--|
| Linear mV Device Input Ranges     | ±39.0625 mVDC,<br>±78.125 mVDC,<br>±156.25 mVDC,<br>0–1250 mVDC,<br>0–39.0625 mVDC,<br>0–156.25 mVDC |
| Max Voltage Input Offset Error    | 0.05% @ 0–60 °C, typical 0.04% @ 25 °C   |
| Max Voltage Input Gain Error      | 0.06% @ 25 °C  |
| Max Voltage Input Linearity Error | 0.05% @ 0–60 °C, typical 0.03% @ 25 °C   |
| Max Voltage Input Impedance       | 0.2% @ 0–60 °C, typical 0.06% @ 25 °C  |

# P1-04THMS Analog Input (continued)

| General Specifications        |  |
|-------------------------------|--|
| Operating Temperature         | 0 to 60 °C (32 to 140 °F)  |
| Storage Temperature           | -20 to +70 °C (-4 to +158 °F)  |
| Humidity                      | 5 to 95% (non-condensing)  |
| Altitude                      | 2000 meters max.   |
| Pollution Degree              | 2  |
| Environmental Air             | No corrosive gases permitted   |
| Vibration                     | IEC60068-2-6 (Test Fc)   |
| Shock                         | IEC60068-2-27 (Test Ea)  |
| Overvoltage Category          | II   |
| Field to Logic Side Isolation | 1750 VAC applied for 5 s or 420 VDC applied for 1 minute   |
| Input to Input Isolation      | 1750 VAC applied for 5 s or 420 VDC applied for 1 minute   |
| Heat Dissipation              | 100 mW   |
| Enclosure Type                | Open equipment   |
| Module Location               | Any I/O position in a Productivity®1000 system   |
| Field Wiring                  | Removable terminal block (included). The P1-04THMS module is not compatible with the Z/PLink wiring system.              |
| Connector Type (Included)     | 18-position removable terminal block   |
| Weight                        | 67 g (2.36 oz)   |
| Agency Approvals              | UL 61010-1 and UL 61010-2-201 File E133024, Canada and USA<br>CE (EN 61131-2 EMC, EN 61010-1 and EN 61010-2-201 Safety)* |

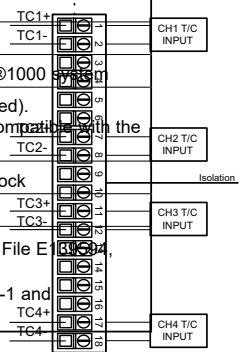

\* See CE Declaration of Conformance for details.

| Configuration/Diagnostics  |                   |
|--|-------------------|
| Burn-out Detection: High Side/Disable                                    | 1 bit per module  |
| °C/°F (T/C Only)   | 1 bit per module  |
| Module Diagnostics Failure   | 1 bit per module  |
| Burn-out (on if T/C input is open – no connection between TCn+ and TCn-) | 1 bit per channel |
| Channel Under-range  | 1 bit per channel |
| Channel Over-range   | 1 bit per channel |

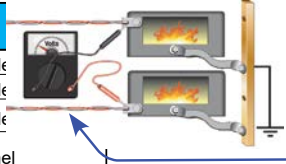

## P1-04THMS Analog Input (continued)

| Removable Terminal Block Specifications |   |   |
|---|---|---|
| Part Number                             | P2-RTB (included)   | P2-RTB-1  |
| Number of positions                     | 18 screw terminals  | 18 spring clamp terminals   |
| Wire Range                              | 30–16 AWG (0.051–1.31 mm <sup>2</sup> )<br>Solid/stranded conductor<br>3/64 in. (1.2 mm) insulation max.<br>1/4 in (6– 7 mm) strip length | 28–16 AWG (0.081–1.31 mm <sup>2</sup> )<br>Solid/stranded conductor<br>3/64 in (1.2 mm) insulation max.<br>19/64 in (7–8 mm) strip length |
| Conductors                              | USE COPPER CONDUCTORS, 75°C or equivalent.  |   |
| Screw Driver                            | 0.1 in (2.5 mm) maximum*  |   |
| Screw Size                              | M2  | N/A   |
| Screw Torque                            | 2.5 lb-in (0.28 N·m)  | N/A   |

\* Recommended screw driver P/N: TW-SD-MSL-1.

### Wiring Diagrams

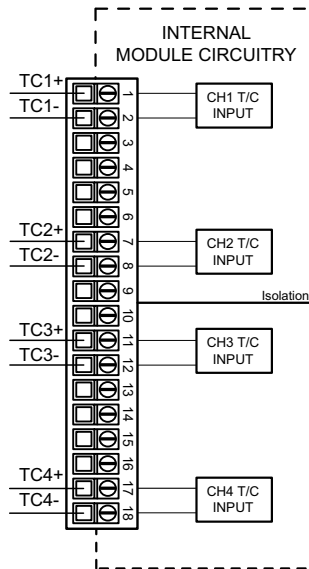

## P1-04THMS Analog Input (continued)

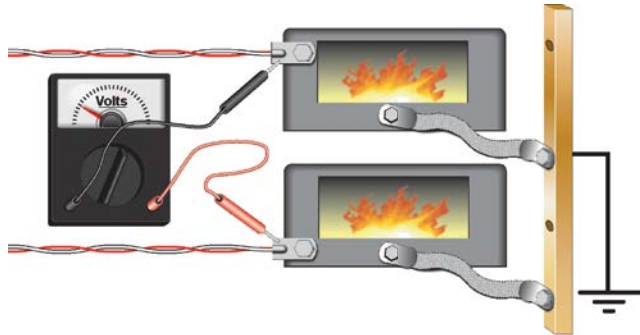
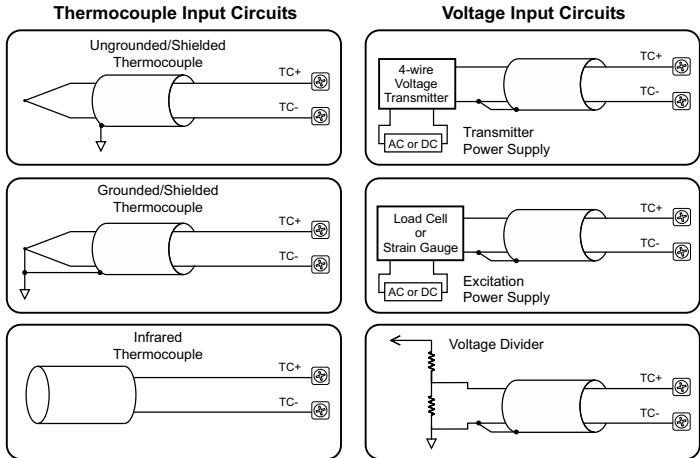

**NOTES:**

1. Connect shield to thermocouple signal/ground only. Do not connect to both ends.
2. Install jumper wire on each unused input, TC+ to TC-.
3. With grounded thermocouples, take precautions to prevent having a voltage potential between thermocouple tips. A voltage of 1.25 V or greater between tips will skew measurements.
4. Use shielded, twisted thermocouple extension wire that matches the thermocouple type. Use thermocouple-compatible junction blocks.
5. Two separate isolations in the field side. Each isolation consists of a pair of channels.



# P1-04THMS Analog Input (continued)

## Module Configuration

Using the Hardware Configuration tool in the Productivity Suite programming software, drag and drop the P1-04THMS module into the configuration.

Specify *Temperature Scale* and *Burnout Detection*, and use the drop down menu to select module range and resolution. If desired, assign a *User Tagname* to each channel selected and to each *Status Bit Item*.

P1-04THMS

4CH, 16-BIT, THERMOCOUPLE INPUT

Temperature Scale Degrees F

Burnout Detection Low Side Burnout Detection

Add Default Tags Remove Default Tags

| Point | User Tagname  | Ch. Select                              | Range  | Burnout Error | Under Range Error | Over Range Error |
|-------|---------------|---|--------|---------------|-------------------|------------------|
| 1     | AIF32-0.1.1.1 | All <input checked="" type="checkbox"/> | Type J | MST-0.1.1.41  | MST-0.1.1.57      | MST-0.1.1.89     |
| 2     | AIF32-0.1.1.2 | <input checked="" type="checkbox"/>     | Type J | MST-0.1.1.42  | MST-0.1.1.58      | MST-0.1.1.90     |
| 3     | AIF32-0.1.1.3 | <input checked="" type="checkbox"/>     | Type J | MST-0.1.1.43  | MST-0.1.1.59      | MST-0.1.1.91     |
| 4     | AIF32-0.1.1.4 | <input checked="" type="checkbox"/>     | Type J | MST-0.1.1.44  | MST-0.1.1.60      | MST-0.1.1.92     |

| Status Bit       | User Tagname |
|------------------|--------------|
| Module Failed    | MST-0.1.1.25 |
| Module Not Ready | MST-0.1.1.27 |

Module Info Monitor OK Cancel Help

## P1-04THM Analog Input

The P1-04THM Thermocouple Input Module provides four differential channels for receiving thermocouple and voltage input signals for use with the Productivity®1000 system.

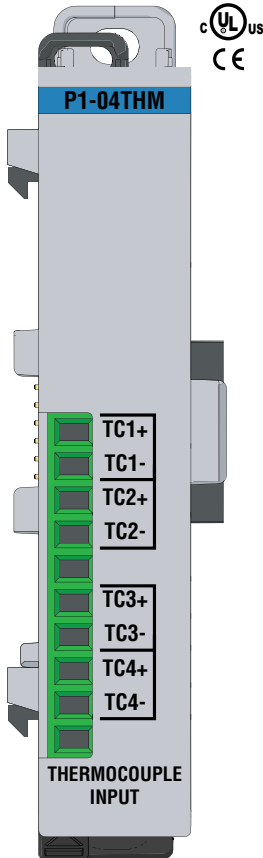

**Terminal Block Included.  
Not Compatible with Z/PLink.**

**Warranty: Thirty-day money-back guarantee. Two-year limited replacement. (See www.productivity1000.com for details).**

### Thermocouple Input Specifications

|                                |  |
|--------------------------------|--|
| Input Channels                 | 4 Differential   |
| Data Format                    | Floating Point   |
| Common Mode Range              | ±0.5 V   |
| Common Mode Rejection          | 100dB @ DC   |
| Input Impedance                | >5MΩ   |
| Maximum Ratings                | Fault protected inputs to ±50V   |
| Resolution                     | 16-bit, ±0.1°C or °F   |
| Thermocouple Input Ranges      | Type J - 190° to 760°C (-310° to 1400°F);<br>Type E - 210° to 1000°C (-346° to 1832°F);<br>Type K - 150° to 1372°C (-238° to 2502°F);<br>Type R - 65° to 1768°C (149° to 3214°F);<br>Type S - 65° to 1768°C (149° to 3214°F);<br>Type T - 230° to 400°C (-382° to 752°F);<br>Type B - 529° to 1820°C (984° to 3308°F);<br>Type N - 70° to 1300°C (-94° to 2372°F);<br>Type C - 65° to 2320°C (149° to 4208°F); |
| Thermocouple Linearization     | Automatic  |
| Cold Junction Compensation     | Automatic  |
| Sample Duration Time           | 270ms  |
| All Channel Update Rate        | 1.08 s   |
| Open Circuit Detection Time    | Within 5s  |
| Conversion Method              | Sigma-Delta  |
| Accuracy vs. Temperature       | ±50ppm per °C (maximum)  |
| Maximum Inaccuracy             | ±3°C maximum (excluding thermocouple error).   |
| Linearity Error                | ±1°C maximum (±0.5°C typical)<br>Monotonic with no missing codes.  |
| Warm-up Time                   | 30 minutes for ±1% repeatability<br>2 minutes to reach voltage specifications  |
| External Power Supply Required | None   |

### Voltage Input Specifications

|                                   |  |
|-----------------------------------|--|
| Linear mV Device Input Ranges     | 0–39.0625 mVDC,<br>±39.0625 mVDC,<br>±78.125 mVDC,<br>0–156.25 mVDC,<br>±156.25 mVDC,<br>0–1250 mVDC |
| Max Voltage Input Offset Error    | 0.05% @ 0°– 60°C, typical 0.04% @ 25°C   |
| Max Voltage Input Gain Error      | 0.06% @ 25°C   |
| Max Voltage Input Linearity Error | 0.05% @ 0°– 60°C, typical 0.03% @ 25°C   |
| Max Voltage Input Impedance       | 0.2% @ 0°– 60°C, typical 0.06% @ 25°C  |

## P1-04THM Analog Input (continued)

| General Specifications        |  |
|-------------------------------|--|
| Operating Temperature         | 0°C– 60°C (32°F–140°F)   |
| Storage Temperature           | -20°C–70°C (-4°F–158°F)  |
| Humidity                      | 5 to 95% (non-condensing)  |
| Altitude                      | 2000 meters max.   |
| Pollution Degree              | 2  |
| Environmental Air             | No corrosive gases permitted   |
| Vibration                     | IEC60068-2-6 (Test Fc)   |
| Shock                         | IEC60068-2-27 (Test Ea)  |
| Overvoltage Category          | II   |
| Field to Logic Side Isolation | 1800VAC applied for 1s   |
| Heat Dissipation              | 100mW  |
| Enclosure Type                | Open equipment   |
| Module Location               | Any I/O position in a Productivity®1000 system   |
| Field Wiring                  | Removable terminal block (included).<br>The P1-04THM module is not compatible with the ZIPLink wiring system.                  |
| Connector Type (Included)     | 10-position removable terminal block   |
| Weight                        | 58g (2.0 oz)   |
| Agency Approvals              | UL 61010-1 and UL 61010-2-201 File E139594,<br>Canada and USA<br>CE (EN 61131-2 EMC, EN 61010-1 and<br>EN 61010-2-201 Safety)* |

\* See CE Declaration of Conformance for details.

| Configuration/Diagnostics  |                   |
|--|-------------------|
| Burn-out Detection: High Side/Disable                                    | 1 bit per module  |
| °C/°F (T/C Only)   | 1 bit per module  |
| Module Diagnostics Failure   | 1 bit per module  |
| Burn-out (on if T/C input is open – no connection between TCn+ and TCn-) | 1 bit per channel |
| Channel Under-range (T/C only)   | 1 bit per channel |
| Channel Over-range (T/C only)  | 1 bit per channel |

## P1-04THM Analog Input (continued)

| Removable Terminal Block Specifications |   |   |
|---|---|---|
| Part Number                             | P1-10RTB  | P1-10RTB-1  |
| Number of positions                     | 10 screw terminals  | 10 spring clamp terminals   |
| Wire Range                              | 30–16 AWG (0.051–1.31 mm <sup>2</sup> )<br>Solid/stranded conductor<br>3/64 in. (1.2 mm) insulation max.<br>1/4 in (6– 7 mm) strip length | 28–16 AWG (0.081–1.31 mm <sup>2</sup> )<br>Solid/stranded conductor<br>3/64 in (1.2 mm) insulation max.<br>19/64 in (7–8 mm) strip length |
| Conductors                              | USE COPPER CONDUCTORS, 75°C or equivalent.  |   |
| Screw Driver                            | 0.1 in (2.5 mm) maximum*  |   |
| Screw Size                              | M2  | N/A   |
| Screw Torque                            | 2.5 lb-in (0.28 N-m)  | N/A   |

\* Recommended screw driver P/N: TW-SD-MSL-1.

### Wiring Diagrams

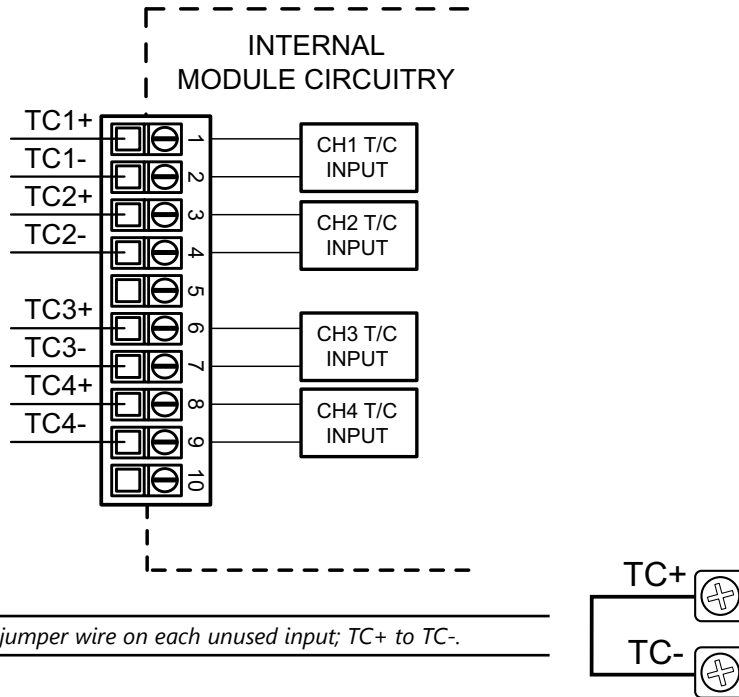

# P1-04THM Analog Input (continued)

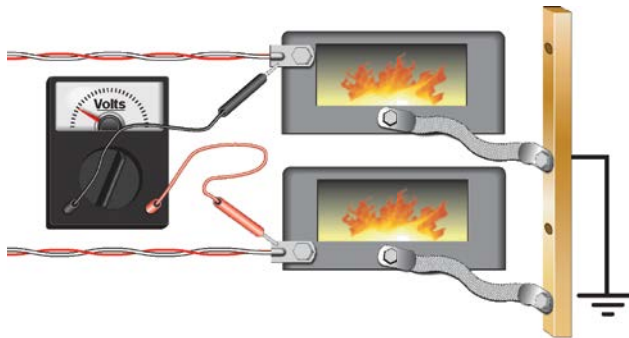
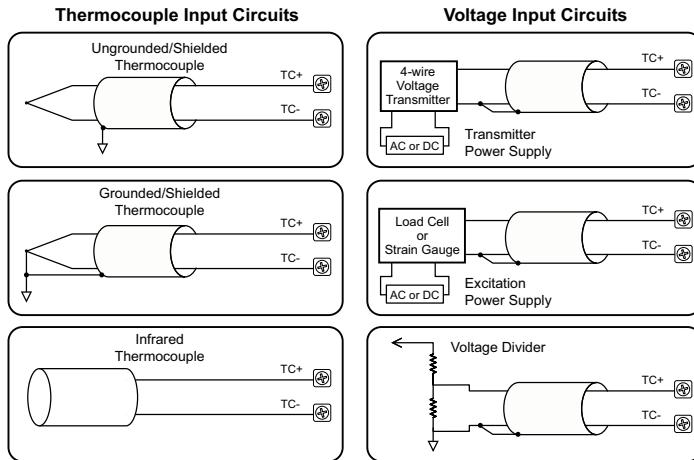

**NOTES:**

1. Connect shield to thermocouple signal/ground only. Do not connect to both ends.

2. Install jumper wire on each unused input, TC+ to TC-.



3. With grounded thermocouples, take precautions to prevent having a voltage potential between thermocouple tips. A voltage of 0.5V or greater between tips will skew measurements.

4. Use shielded, twisted thermocouple extension wire that matches the thermocouple type. Use thermocouple-compatible junction blocks.

# P1-04THM Analog Input (continued)

## Module Configuration

Using the Hardware Configuration tool in the Productivity Suite programming software, drag and drop the P1-04THM module into the base configuration. Select *Automatic Module Verification* or *No Verification*. Specify *Temperature Scale* and *Burnout Detection*, and use the drop down menu to select module range and resolution. If desired, assign a *User Tagname* to each output point channel selected and to each *Status Bit Item*.

4CH, 16-BIT, THERMOCOUPLE INPUT

Temperature Scale: Degrees F

Burnout Detection: Low Side Burnout Detection

Add Default Tags Remove Default Tags

| Point | User Tagname  | Ch. Select                              | Range  | Burnout Error | Under Range Error | Over Range Error |
|-------|---------------|---|--------|---------------|-------------------|------------------|
| 1     | AIF32-0.1.1.1 | All <input checked="" type="checkbox"/> | Type J | MST-0.1.1.41  | MST-0.1.1.57      | MST-0.1.1.89     |
| 2     | AIF32-0.1.1.2 | <input checked="" type="checkbox"/>     | Type J | MST-0.1.1.42  | MST-0.1.1.58      | MST-0.1.1.90     |
| 3     | AIF32-0.1.1.3 | <input checked="" type="checkbox"/>     | Type J | MST-0.1.1.43  | MST-0.1.1.59      | MST-0.1.1.91     |
| 4     | AIF32-0.1.1.4 | <input checked="" type="checkbox"/>     | Type J | MST-0.1.1.44  | MST-0.1.1.60      | MST-0.1.1.92     |

Status Bit User Tagname

Module Failed MST-0.1.1.25

Module Not Ready MST-0.1.1.27

Module Info Monitor OK Cancel Help

## P1-04NTC Thermistor

The P1-04NTC module provides four Thermistor input channels for use with the Productivity®1000 system.

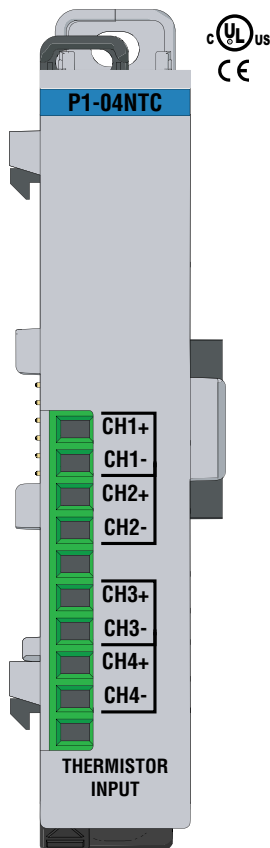

| NTC Input Specifications       |   |                               |
|--------------------------------|---|-------------------------------|
| Input Channels                 | 4 Single Ended (Temperature only)   |                               |
| Data Format                    | Floating Point  |                               |
| Common Mode Rejection          | 100dB @ DC  |                               |
| Input Impedance                | >5MΩ  |                               |
| Maximum Ratings                | Fault protected inputs to ±50V  |                               |
| Resolution                     | 16-bit, ±0.1°C or °F  |                               |
| Thermistor Input Ranges        | 2252<br>10K-AN Type 3<br>10K-CP Type 2<br>5K<br>3K<br>1.8 K   | -40° to 150°C (-40° to 300°F) |
| Thermistor Linearization       | Automatic   |                               |
| Sample Duration                | Dependent on digital filter settings -<br>61ms @ 33Hz; 4ms @ 470Hz  |                               |
| Sample Duration Time           | Per channel: 61ms @ 33Hz, 4ms @ 470Hz   |                               |
| All Channel Update Rate        | 1.2 s @ 33Hz; 300ms @ 470Hz   |                               |
| Open Circuit Detection Time    | Within 5s @ 33Hz  |                               |
| Conversion Method              | Sigma-Delta   |                               |
| Accuracy vs. Temperature       | ±35PPM per °C (maximum)   |                               |
| Maximum Inaccuracy             | ±1°C maximum (33Hz)<br>±2.5°C maximum (470Hz)<br>(Excluding thermistor error;<br>including temperature drift) |                               |
| Linearity Error                | ±0.5°C maximum (±0.35°C typical)<br>Monotonic with no missing codes   |                               |
| Filter Characteristics         | Digital filter cutoff frequencies: 33Hz, 470Hz.   |                               |
| External Power Supply Required | None  |                               |

**Terminal Block Included.**  
**Not Compatible with ZIPLink.**

**Warranty: Thirty-day money-back guarantee. Two-year limited replacement. (See [www.productivity1000.com](http://www.productivity1000.com) for details).**

## P1-04NTC Thermistor (continued)

| General Specifications        |  |
|-------------------------------|--|
| Operating Temperature         | 0°C– 60°C (32°F–140°F)   |
| Storage Temperature           | -20°C–70°C (-4°F–158°F)  |
| Humidity                      | 5 to 95% (non-condensing)  |
| Environmental Air             | No corrosive gases permitted   |
| Vibration                     | IEC60068-2-6 (Test Fc)   |
| Shock                         | IEC60068-2-27 (Test Ea)  |
| Field to Logic Side Isolation | 1800VAC applied for 1s   |
| Heat Dissipation              | 100mW  |
| Enclosure Type                | Open equipment   |
| Module Location               | Any I/O position in a Productivity@1000 system   |
| Field Wiring                  | Removable terminal block (included).<br>The P1-04NTC module is not compatible with the ZIPLink wiring system.            |
| Connector Type (included)     | 10-position removable terminal block   |
| Weight                        | 60g (2.1 oz)   |
| Agency Approvals              | UL 61010-1 and UL 61010-2-201 File E139594, Canada and USA<br>CE (EN 61131-2 EMC, EN 61010-1 and EN 61010-2-201 Safety)* |

\* See CE Declaration of Conformance for details.

| Removable Terminal Block Specifications |   |   |
|---|---|---|
| Part Number                             | P1-10RTB  | P1-10RTB-1  |
| Number of positions                     | 10 screw terminals  | 10 spring clamp terminals   |
| Wire Range                              | 30–16 AWG (0.051–1.31 mm <sup>2</sup> )<br>Solid/stranded conductor<br>3/64 in. (1.2 mm) insulation max.<br>1/4 in (6– 7 mm) strip length | 28–16 AWG (0.081–1.31 mm <sup>2</sup> )<br>Solid/stranded conductor<br>3/64 in (1.2 mm) insulation max.<br>19/64 in (7–8 mm) strip length |
| Conductors                              | USE COPPER CONDUCTORS, 75°C or equivalent.  |   |
| Screw Driver                            | 0.1 in (2.5 mm) maximum*  |   |
| Screw Size                              | M2  | N/A   |
| Screw Torque                            | 2.5 lb·in (0.28 N·m)  | N/A   |

\* Recommended screw driver P/N: TW-SD-MSL-1.

# P1-04NTC Thermistor (continued)

## Wiring Diagrams

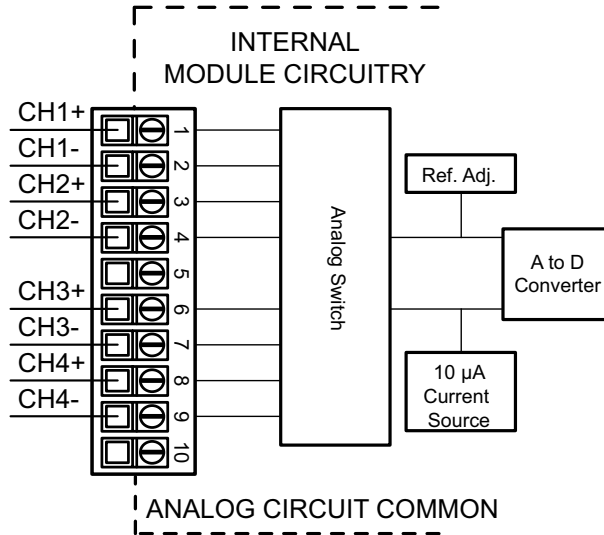

**NOTE:** Install jumper wire on each unused input; CH+ to CH-.

### Thermistor Input

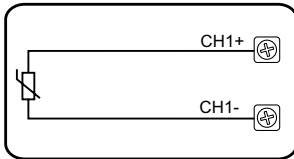

### Jumpers

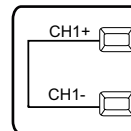

# P1-04NTC Thermistor (continued)

## Module Configuration

Using the Hardware Configuration tool in the Productivity Suite programming software, drag and drop the P1-04NTC module into the base configuration. Specify *Temperature Scale* and *Burnout Detection*, and use the drop down menu to select module range and resolution. If desired, assign a *User Tagname* to each output point channel selected and to each *Status Bit Item*.

4CH, 16-BIT, THERMISTOR INPUT

Input Range: 2252    Temperature Scale: Degrees F

Digital Filter: 6.1 msec    Burnout Detection: Low Side Burnout Detection

Add Default Tags    Remove Default Tags

| Point | User Tagname  | Ch. Select                          | Burnout Error | Under Range Error | Over Range Error |
|-------|---------------|-------------------------------------|---------------|-------------------|------------------|
| 1     | AIF32-0.1.1.1 | <input checked="" type="checkbox"/> | MST-0.1.1.41  | MST-0.1.1.57      | MST-0.1.1.89     |
| 2     | AIF32-0.1.1.2 | <input checked="" type="checkbox"/> | MST-0.1.1.42  | MST-0.1.1.58      | MST-0.1.1.90     |
| 3     | AIF32-0.1.1.3 | <input checked="" type="checkbox"/> | MST-0.1.1.43  | MST-0.1.1.59      | MST-0.1.1.91     |
| 4     | AIF32-0.1.1.4 | <input checked="" type="checkbox"/> | MST-0.1.1.44  | MST-0.1.1.60      | MST-0.1.1.92     |

Status Bit    User Tagname

Module Failed    MST-0.1.1.25

Module Not Ready    MST-0.1.1.27

Module Info    Monitor    OK    Cancel    Help

# P1-04DAL-1 Analog Output

The P1-04DAL-1 Low Resolution Analog Output Module provides four current sourcing channels for converting a digital value of 0–4095 (12-bit) to 4–20 mA analog signals for use with the Productivity®1000 system.

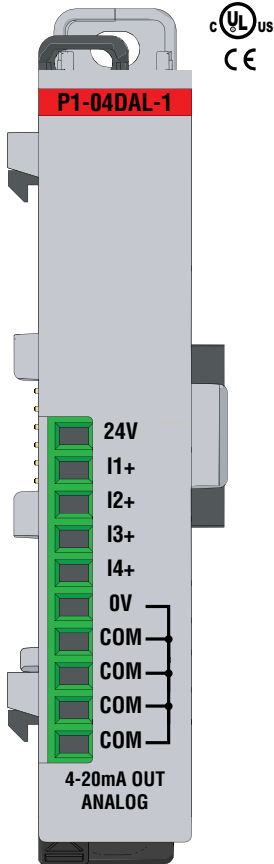

Terminal block sold separately.

| Output Specifications                                   |   |
|---|---|
| Output Channels   | 4   |
| Output Range  | 4–20 mA   |
| Signal Resolution                                       | 12-bit  |
| Resolution Value of LSB (least significant bit)         | 4–20 mA = 3.9 $\mu$ A / count<br>1 LSB = 1 count  |
| Data Range  | 0 to 4095 counts  |
| Output Type (sourcing)                                  | Current sourcing at 20mA max  |
| Output Value in Fault Mode                              | Less than 4mA   |
| Load Impedance  | 0–570 $\Omega$ (19.2 VDC),<br>0–690 $\Omega$ (21.6 VDC),<br>0–810 $\Omega$ (24VDC),<br>0–930 $\Omega$ (26.4 VDC),<br>0–1100 $\Omega$ (30.0 VDC),<br>Minimum Load: 0 $\Omega$ @ 0–45°C<br>125 $\Omega$ @ 45–60°C ambient temperature |
| Maximum Inductive Load                                  | 1mH   |
| Allowed Load Type                                       | Grounded  |
| Maximum Inaccuracy                                      | 1% of range   |
| Maximum Full Scale Calibration Error (Including Offset) | $\pm$ 0.2% of range minimum   |
| Maximum Offset Calibration Error                        | $\pm$ 0.2% of range maximum   |
| Accuracy vs. Temperature                                | $\pm$ 75PPM / °C maximum full-scale calibration change ( $\pm$ 0.005% of range / °C)  |
| Max Crosstalk at DC, 50/60Hz                            | -72dB, 1 LSB  |
| Linearity Error (End to End)                            | $\pm$ 4 counts max., ( $\pm$ 0.1% of full scale)  |
| Output Stability and Repeatability                      | $\pm$ 2 count after 10 min. warm up (typical)   |
| Output Ripple   | $\pm$ 0.2% of full scale  |
| Output Settling Time                                    | 0.3 ms max., 5 $\mu$ s min. (full scale range)  |
| All Channel Update Rate                                 | 2ms (max)   |
| Maximum Continuous Overload                             | Outputs open circuit protected  |
| Type of Output Protection                               | Electronically current limited to 20mA or less  |
| Output Signal at Power Up and Power Down                | 4mA   |
| External Power Supply Required                          | 24VDC (-20% / +25%), 140mA (Loop power included)  |

We recommend using pre-wired ZIPLink cables and connection modules. See Chapter 5. If you wish to hand-wire your module, removable terminal blocks are sold separately. Order part number P1-10RTB or P1-10RTB-1



## P1-04DAL-1 Analog Output (continued)

| General Specifications          |  |
|---------------------------------|--|
| Operating Temperature           | 0°C– 60°C (32°F–140°F)   |
| Storage Temperature             | -20°C–70°C (-4°F–158°F)  |
| Humidity                        | 5 to 95% (non-condensing)  |
| Environmental Air               | No corrosive gases permitted   |
| Vibration                       | IEC60068-2-6 (Test Fc)   |
| Shock                           | IEC60068-2-27 (Test Ea)  |
| Field to Logic Side Isolation   | 1800VAC applied for 1s   |
| Insulation Resistance           | >10MΩ @ 500VDC   |
| Heat Dissipation                | 3000mW Maximum   |
| Enclosure Type                  | Open equipment   |
| Module Location                 | Any I/O position in a Productivity@1000 system   |
| Field Wiring                    | Use ZIPLink wiring system or removable terminal block (not included). See "Wiring Options" in Chapter 5.                 |
| Terminal Type (sold separately) | 10-position removable terminal block   |
| Weight                          | 85.1 g (3.0 oz)  |
| Agency Approvals                | UL 61010-1 and UL 61010-2-201 File E139594, Canada and USA<br>CE (EN 61131-2 EMC, EN 61010-1 and EN 61010-2-201 Safety)* |

\* See CE Declaration of Conformance for details.

| Removable Terminal Block Specifications |   |   |
|---|---|---|
| Part Number                             | P1-10RTB  | P1-10RTB-1  |
| Number of positions                     | 10 screw terminals  | 10 spring clamp terminals   |
| Wire Range                              | 30–16 AWG (0.051–1.31 mm <sup>2</sup> )<br>Solid/stranded conductor<br>3/64 in. (1.2 mm) insulation max.<br>1/4 in (6– 7 mm) strip length | 28–16 AWG (0.081–1.31 mm <sup>2</sup> )<br>Solid/stranded conductor<br>3/64 in (1.2 mm) insulation max.<br>19/64 in (7–8 mm) strip length |
| Conductors                              | USE COPPER CONDUCTORS, 75°C or equivalent.  |   |
| Screw Driver                            | 0.1 in (2.5 mm) maximum*  |   |
| Screw Size                              | M2  | N/A   |
| Screw Torque                            | 2.5 lb·in (0.28 N·m)  | N/A   |

\* Recommended screw driver P/N: TW-SD-MSL-1.

# P1-04DAL-1 Analog Output (continued)

## Wiring Diagrams

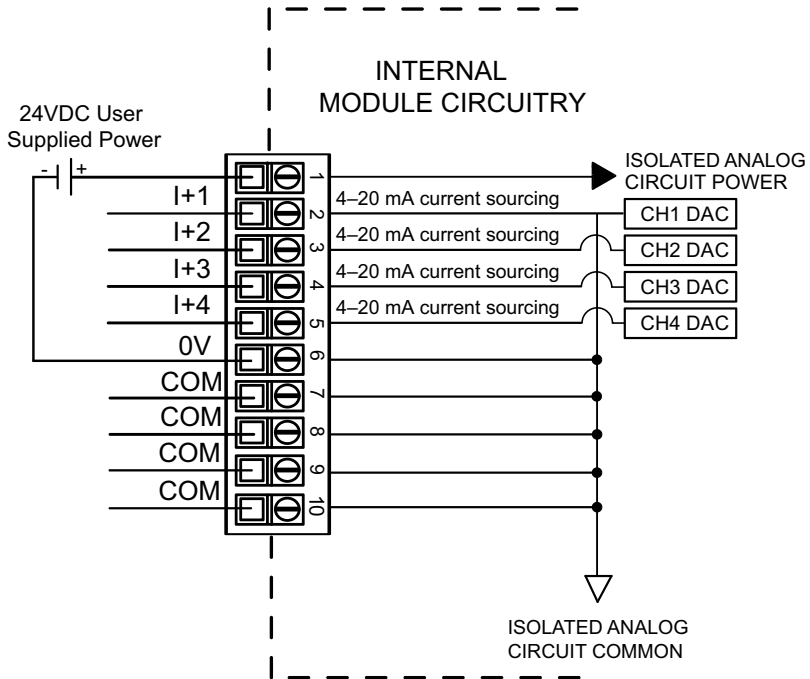

Current Source Output Circuit

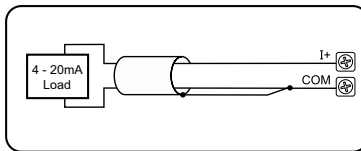

Note: Shield is connected to common at the source device.

# P1-04DAL-1 Analog Output (continued)

## Module Configuration

Using the Hardware Configuration tool in the Productivity Suite programming software, drag and drop the P1-04DAL-1 module into the base configuration.

If desired, assign a *User Tagname* to each output point channel selected and to each *Status Bit Item*. A *Stop Mode Value* may also be assigned.

4CH, 12-BIT, CURRENT, 4-20mA, ANALOG OUTPUT

Add Default Tags Remove Default Tags

| Point | User Tagname  | Stop Mode Value |
|-------|---------------|-----------------|
| 1     | AOS32-0.1.1.1 | 0               |
| 2     | AOS32-0.1.1.2 | 0               |
| 3     | AOS32-0.1.1.3 | 0               |
| 4     | AOS32-0.1.1.4 | 0               |

| Status Bit    | User Tagname |
|---------------|--------------|
| Module Failed | MST-0.1.1.25 |
| Missing 24V   | MST-0.1.1.26 |

Module Info Monitor **OK** Cancel Help

## P1-04DAL-2 Analog Output

The P1-04DAL-2 Low Resolution Voltage Analog Output Module provides four outputs for converting digital values from 0–4095 (12-bit) to 0–10 VDC analog signals for use with the Productivity®1000 system.

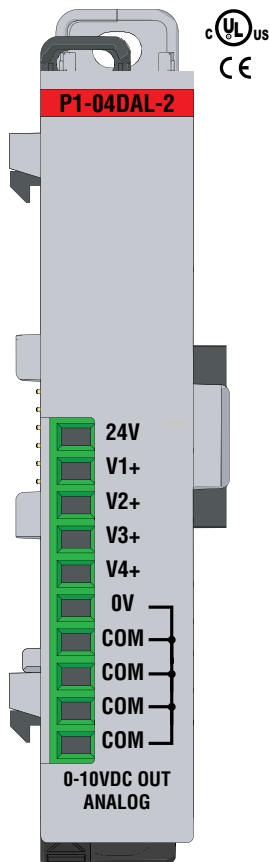

Terminal block sold separately.

| Output Specifications                                       |  |
|---|--|
| Output Channels   | 4  |
| Module Signal Input Range                                   | 0–10 V   |
| Output Signal Resolution                                    | 12-bit   |
| Resolution Value of LSB (least significant bit)             | 0–10 V = 2.44 mV per count<br>1 LSB = 1 count  |
| Data Range  | 0 to 4095 counts   |
| Output Type   | Voltage sourcing at 10mA   |
| Output Value in Fault Mode                                  | 0V   |
| Load Impedance  | ≥1000Ω   |
| Maximum Capacitive Load                                     | 0.01 μF  |
| Allowed Load Type   | Grounded   |
| Maximum Inaccuracy  | 0.5% of range  |
| Maximum Full Scale Calibration Error (Not Including Offset) | ±0.2% of range   |
| Maximum Offset Calibration Error                            | ±0.2% of range   |
| Accuracy vs. Temperature                                    | ±75PPM / °C maximum full-scale calibration change<br>(±0.0025% of range / °C)                              |
| Max Crosstalk   | -72dB, 1 LSB   |
| Linearity Error (End to End)                                | ±4 LSB maximum, (±0.1% of full scale)<br>Monotonic with no missing codes                                   |
| Output Stability and Repeatability                          | ±2% LSB after 10 min. warm up (typical)  |
| Output Ripple   | ±0.2% of full scale  |
| Output Settling Time  | 0.3 ms max., 5μs min. (full scale range)   |
| All Channel Update Rate (typical)                           | 2ms  |
| Maximum Continuous Overload                                 | Outputs current limited to 40mA typical<br>Continuous overloads on multiple outputs can damage the module. |
| Type of Output Protection                                   | 0.1 μF Transient Suppressor  |
| Output Signal at Power Up and Power Down                    | 0V   |
| External Power Supply Required                              | 24VDC (-20% / +25%), 100mA   |

We recommend using pre-wired ZIPLink cables and connection modules. See Chapter 5.

If you wish to hand-wire your module, removable terminal blocks are sold separately. Order part number P1-10RTB or P1-10RTB-1



## P1-04DAL-2 Analog Output (continued)

| General Specifications        |  |
|-------------------------------|--|
| Operating Temperature         | 0°C– 60°C (32°F–140°F)   |
| Storage Temperature           | -20°C–70°C (-4°F–158°F)  |
| Humidity                      | 5 to 95% (non-condensing)  |
| Environmental Air             | No corrosive gases permitted   |
| Vibration                     | IEC60068-2-6 (Test Fc)   |
| Shock                         | IEC60068-2-27 (Test Ea)  |
| Field to Logic Side Isolation | 1800VAC applied for 1s   |
| Insulation Resistance         | >10MΩ @ 500VDC   |
| Heat Dissipation              | 2000mW   |
| Enclosure Type                | Open equipment   |
| Module Location               | Any I/O position in a Productivity@1000 system   |
| Field Wiring                  | Use ZIPLink wiring system or removable terminal block (not included). See "Wiring Options" in Chapter 5.                 |
| Connector Type (Not included) | 10-position removable terminal block   |
| Weight                        | 62g (2.2 oz)   |
| Agency Approvals              | UL 61010-1 and UL 61010-2-201 File E139594, Canada and USA<br>CE (EN 61131-2 EMC, EN 61010-1 and EN 61010-2-201 Safety)* |

\* See CE Declaration of Conformance for details.

| Removable Terminal Block Specifications |   |   |
|---|---|---|
| Part Number                             | P1-10RTB  | P1-10RTB-1  |
| Number of positions                     | 10 screw terminals  | 10 spring clamp terminals   |
| Wire Range                              | 30–16 AWG (0.051–1.31 mm <sup>2</sup> )<br>Solid/stranded conductor<br>3/64 in. (1.2 mm) insulation max.<br>1/4 in (6– 7 mm) strip length | 28–16 AWG (0.081–1.31 mm <sup>2</sup> )<br>Solid/stranded conductor<br>3/64 in (1.2 mm) insulation max.<br>19/64 in (7–8 mm) strip length |
| Conductors                              | USE COPPER CONDUCTORS, 75°C or equivalent.  |   |
| Screw Driver                            | 0.1 in (2.5 mm) maximum*  |   |
| Screw Size                              | M2  | N/A   |
| Screw Torque                            | 2.5 lb·in (0.28 N·m)  | N/A   |

\* Recommended screw driver P/N: TW-SD-MSL-1.

# P1-04DAL-2 Analog Output (continued)

## Wiring Diagrams

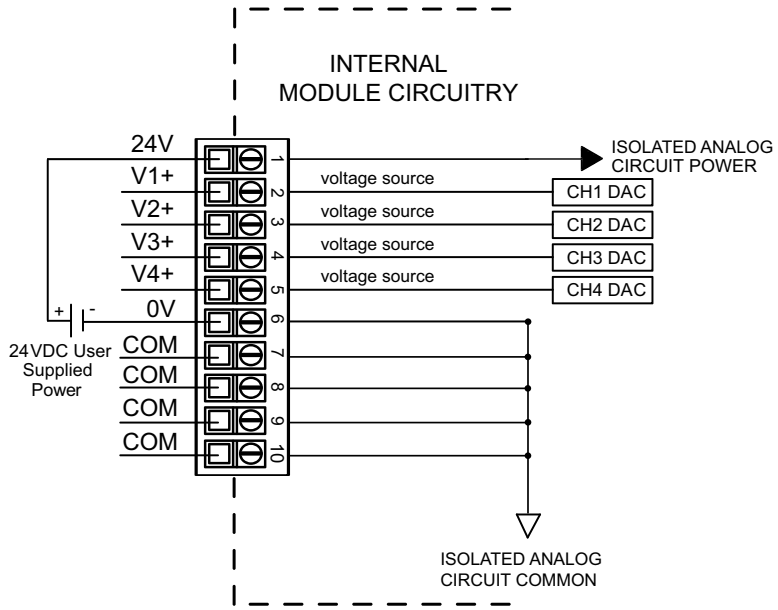

### Voltage Output Circuits

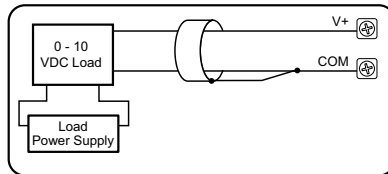

# P1-04DAL-2 Analog Output (continued)

## Module Configuration

Using the Hardware Configuration tool in the Productivity Suite programming software, drag and drop the P1-04DAL-2 module into the base configuration.

If desired, assign a *User Tagname* to each output point channel selected and to each *Status Bit Item*. A *Stop Mode Value* may also be assigned.

4CH, 12-BIT, VOLTAGE, 0-10VDC, ANALOG OUTPUT

Add Default Tags Remove Default Tags

| Point | User Tagname  | Stop Mode Value |
|-------|---------------|-----------------|
| 1     | AOS32-0.1.1.1 | 0               |
| 2     | AOS32-0.1.1.2 | 0               |
| 3     | AOS32-0.1.1.3 | 0               |
| 4     | AOS32-0.1.1.4 | 0               |

| Status Bit    | User Tagname |
|---------------|--------------|
| Module Failed | MST-0.1.1.25 |
| Missing 24V   | MST-0.1.1.26 |

Module Info Monitor **OK** Cancel Help

## P1-08DAL-1 Analog Output

The P1-08DAL-1 Current Analog Output Module provides eight (12-bit) to 4–20 mA analog signals for use with the Productivity®1000 system.

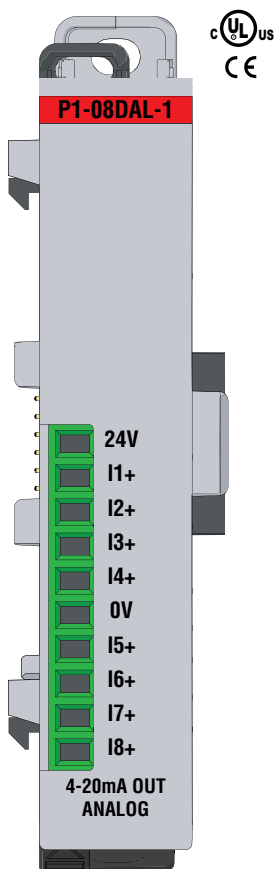

Terminal block sold separately.

### Output Specifications

|   |   |
|---|---|
| Output Channels   | 8   |
| Output Type (sourcing)                                  | Current sourcing at 20mA max  |
| Output Range  | 4–20 mA   |
| Signal Resolution                                       | 12-bit  |
| Resolution Value of LSB (least significant bit)         | 4–20 mA = 3.9 $\mu$ A / count<br>1 LSB = 1 count  |
| Data Range  | 0 to 4095 counts  |
| Output Value in Fault Mode                              | Less than 4mA   |
| Load Impedance  | 0–570 $\Omega$ (19.2 VDC),<br>0–690 $\Omega$ (21.6 VDC),<br>0–810 $\Omega$ (24VDC),<br>0–930 $\Omega$ (26.4 VDC),<br>0–1100 $\Omega$ (30.0 VDC),<br>Minimum Load: 0 $\Omega$ @ 0–45°C<br>125 $\Omega$ @ 45–60°C ambient temperature |
| Maximum Inductive Load                                  | 1mH   |
| Allowed Load Type                                       | Grounded  |
| Maximum Inaccuracy                                      | 1% of range   |
| Maximum Full Scale Calibration Error (Including Offset) | $\pm$ 0.2% of range minimum   |
| Maximum Offset Calibration Error                        | $\pm$ 0.2% of range maximum   |
| Accuracy vs. Temperature                                | $\pm$ 75PPM / °C maximum full-scale calibration change ( $\pm$ 0.005% of range / °C)  |
| Max Crosstalk at DC, 50/60Hz                            | -72dB, 1 LSB  |
| Linearity Error (End to End)                            | $\pm$ 4 LSB max., ( $\pm$ 0.1% of full scale)   |
| Output Stability and Repeatability                      | $\pm$ 2% LSB after 10 min. warm up (typical)  |
| Output Ripple   | $\pm$ 0.1% of full scale  |
| Output Settling Time                                    | 0.3 ms max., 5 $\mu$ s min. (full scale range)  |
| All Channel Update Rate                                 | 10ms (max)  |
| Maximum Continuous Overload                             | Outputs open circuit protected  |
| Type of Output Protection                               | Electronically current limited to 20mA or less  |
| Output Signal at Power Up and Power Down                | 4mA   |
| External Power Supply Required                          | 24VDC @ 160mA   |

We recommend using pre-wired ZIPLink cables and connection modules. See Chapter 5. If you wish to hand-wire your module, removable terminal blocks are sold separately. Order part number P1-10RTB or P1-10RTB-1



## P1-08DAL-1 Analog Output (continued)

| General Specifications          |  |
|---------------------------------|--|
| Operating Temperature           | 0°C– 60°C (32°F–140°F)   |
| Storage Temperature             | -20°C–70°C (-4°F–158°F)  |
| Humidity                        | 5 to 95% (non-condensing)  |
| Environmental Air               | No corrosive gases permitted   |
| Vibration                       | IEC60068-2-6 (Test Fc)   |
| Shock                           | IEC60068-2-27 (Test Ea)  |
| Field to Logic Side Isolation   | 1800VAC applied for 1s   |
| Insulation Resistance           | >10MΩ @ 500VDC   |
| Heat Dissipation                | 6000mW   |
| Enclosure Type                  | Open equipment   |
| Module Location                 | Any I/O position in a Productivity@1000 system   |
| Field Wiring                    | Use ZIPLink wiring system or removable terminal block (not included). See "Wiring Options" in Chapter 5.                 |
| Terminal Type (sold separately) | 10-position removable terminal block   |
| Weight                          | 70g (2.3 oz)   |
| Agency Approvals                | UL 61010-1 and UL 61010-2-201 File E139594, Canada and USA<br>CE (EN 61131-2 EMC, EN 61010-1 and EN 61010-2-201 Safety)* |

\* See CE Declaration of Conformance for details.

| Removable Terminal Block Specifications |   |   |
|---|---|---|
| Part Number                             | P1-10RTB  | P1-10RTB-1  |
| Number of positions                     | 10 screw terminals  | 10 spring clamp terminals   |
| Wire Range                              | 30–16 AWG (0.051–1.31 mm <sup>2</sup> )<br>Solid/stranded conductor<br>3/64 in. (1.2 mm) insulation max.<br>1/4 in (6– 7 mm) strip length | 28–16 AWG (0.081–1.31 mm <sup>2</sup> )<br>Solid/stranded conductor<br>3/64 in (1.2 mm) insulation max.<br>19/64 in (7–8 mm) strip length |
| Conductors                              | USE COPPER CONDUCTORS, 75°C or equivalent.  |   |
| Screw Driver                            | 0.1 in (2.5 mm) maximum*  |   |
| Screw Size                              | M2  | N/A   |
| Screw Torque                            | 2.5 lb·in (0.28 N·m)  | N/A   |

\* Recommended screw driver P/N: TW-SD-MSL-1.

# P1-08DAL-1 Analog Output (continued)

## Wiring Diagrams

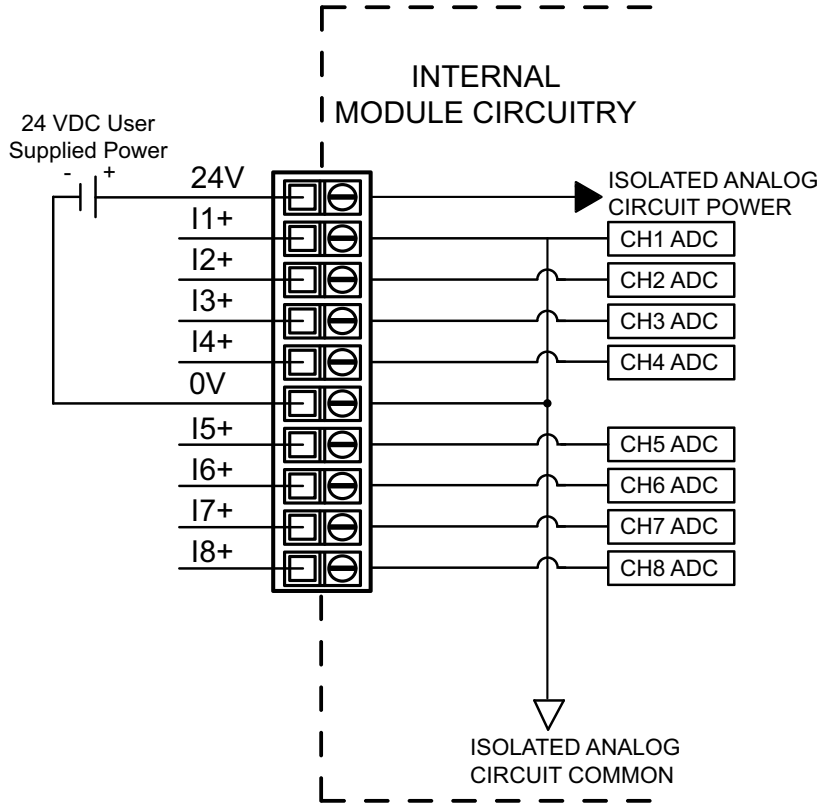

Current Source Output Circuit

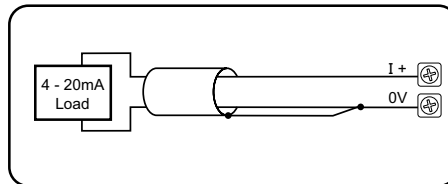

Note: Shield is connected to common at the source device.

# P1-08DAL-1 Analog Output (continued)

## Module Configuration

Using the Hardware Configuration tool in the Productivity Suite programming software, drag and drop the P1-08DAL-1 module into the base configuration.

If desired, assign a *User Tagname* to each input point (channel) selected and to each *Status Bit Item*. A *Stop Mode Value* may be assigned.

8CH, 12-BIT, CURRENT, 4-20mA, ANALOG OUTPUT

Add Default Tags Remove Default Tags

| Point | User Tagname  | Stop Mode Value |
|-------|---------------|-----------------|
| 1     | AOS32-0.1.1.1 | 0               |
| 2     | AOS32-0.1.1.2 | 0               |
| 3     | AOS32-0.1.1.3 | 0               |
| 4     | AOS32-0.1.1.4 | 0               |
| 5     | AOS32-0.1.1.5 | 0               |
| 6     | AOS32-0.1.1.6 | 0               |
| 7     | AOS32-0.1.1.7 | 0               |
| 8     | AOS32-0.1.1.8 | 0               |

| Status Bit    | User Tagname |
|---------------|--------------|
| Module Failed | MST-0.1.1.25 |
| Missing 24V   | MST-0.1.1.26 |

Module Info Monitor **OK** Cancel Help

## P1-08DAL-2 Analog Output

The P1-08DAL-2 Current Analog Output Module provides eight 12-bit channels of 0–10 VDC analog signals for use with the Productivity®1000 system.

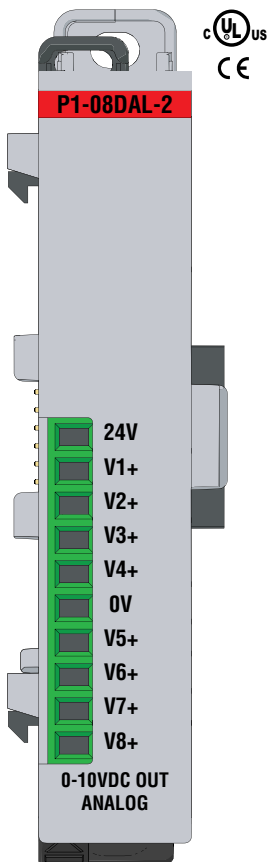

Terminal block sold separately.

| Output Specifications                                   |  |
|---|--|
| Output Channels   | 8  |
| Output Type   | Sinking/sourcing, 10mA max.  |
| Module Signal Input Range                               | 0–10 V   |
| Output Signal Resolution                                | 12-bit   |
| Resolution Value of LSB (least significant bit)         | 0–10 V = 2.44 mV per count<br>1 LSB = 1 count  |
| Data Range  | 0 to 4095 counts   |
| Output Value in Fault Mode                              | 0V   |
| Load Impedance  | ≥1000Ω   |
| Maximum Capacitive Load                                 | 0.01 μF  |
| Allowed Load Type                                       | Grounded   |
| Maximum Inaccuracy                                      | 0.5% of range (Including temperature drift)  |
| Maximum Full Scale Calibration Error (Including Offset) | ±0.2% of range minimum   |
| Maximum Offset Calibration Error                        | ±0.2% of range maximum   |
| Accuracy vs. Temperature                                | ±75PPM / °C maximum full-scale calibration change (±0.0025% of range / °C)                                 |
| Max Crosstalk   | -72dB, 1 LSB   |
| Linearity Error (End to End)                            | ±4 LSB maximum, (±0.1% of full scale)<br>Monotonic with no missing codes                                   |
| Output Stability and Repeatability                      | ±2% LSB after 10 min. warm up (typical)  |
| Output Ripple   | ±0.1% of full scale  |
| Output Settling Time                                    | 300μs max., 5μs min. (full scale range)  |
| All Channel Update Rate (typical)                       | 1ms  |
| Maximum Continuous Overload                             | Outputs current limited to 40mA typical<br>Continuous overloads on multiple outputs can damage the module. |
| Type of Output Protection                               | 0.1 μF Transient Suppressor  |
| Output Signal at Power Up and Power Down                | 0V   |
| External Power Supply Required                          | 24VDC (-20% / +25%), 100mA   |

We recommend using pre-wired ZIPLink cables and connection modules. See Chapter 5. If you wish to hand-wire your module, removable terminal blocks are sold separately. Order part number P1-10RTB or P1-10RTB-1



## P1-08DAL-2 Analog Output (continued)

| General Specifications        |  |
|-------------------------------|--|
| Operating Temperature         | 0°C– 60°C (32°F–140°F)   |
| Storage Temperature           | -20°C–70°C (-4°F–158°F)  |
| Humidity                      | 5 to 95% (non-condensing)  |
| Environmental Air             | No corrosive gases permitted   |
| Vibration                     | IEC60068-2-6 (Test Fc)   |
| Shock                         | IEC60068-2-27 (Test Ea)  |
| Field to Logic Side Isolation | 1800VAC applied for 1s   |
| Insulation Resistance         | >10MΩ @ 500VDC   |
| Heat Dissipation              | 3250mW   |
| Enclosure Type                | Open equipment   |
| Module Location               | Any I/O position in a Productivity@1000 system   |
| Field Wiring                  | Use ZIPLink wiring system or removable terminal block (not included). See "Wiring Options" in Chapter 5.                 |
| Connector Type (Not included) | 10-position removable terminal block   |
| Weight                        | 72g (2.5 oz)   |
| Agency Approvals              | UL 61010-1 and UL 61010-2-201 File E139594, Canada and USA<br>CE (EN 61131-2 EMC, EN 61010-1 and EN 61010-2-201 Safety)* |

\* See CE Declaration of Conformance for details.

| Removable Terminal Block Specifications |   |   |
|---|---|---|
| Part Number                             | P1-10RTB  | P1-10RTB-1  |
| Number of positions                     | 10 screw terminals  | 10 spring clamp terminals   |
| Wire Range                              | 30–16 AWG (0.051–1.31 mm <sup>2</sup> )<br>Solid/stranded conductor<br>3/64 in. (1.2 mm) insulation max.<br>1/4 in (6– 7 mm) strip length | 28–16 AWG (0.081–1.31 mm <sup>2</sup> )<br>Solid/stranded conductor<br>3/64 in (1.2 mm) insulation max.<br>19/64 in (7–8 mm) strip length |
| Conductors                              | USE COPPER CONDUCTORS, 75°C or equivalent.  |   |
| Screw Driver                            | 0.1 in (2.5 mm) maximum*  |   |
| Screw Size                              | M2  | N/A   |
| Screw Torque                            | 2.5 lb·in (0.28 N·m)  | N/A   |

\* Recommended screw driver P/N: TW-SD-MSL-1.



# P1-08DAL-2 Analog Output (continued)

## Module Configuration

Using the Hardware Configuration tool in the Productivity Suite programming software, drag and drop the P1-08DAL-2 module into the base configuration.

If desired, assign a *User Tagname* to each input point (channel) selected and to each *Status Bit Item*. A *Stop Mode Value* may be assigned.

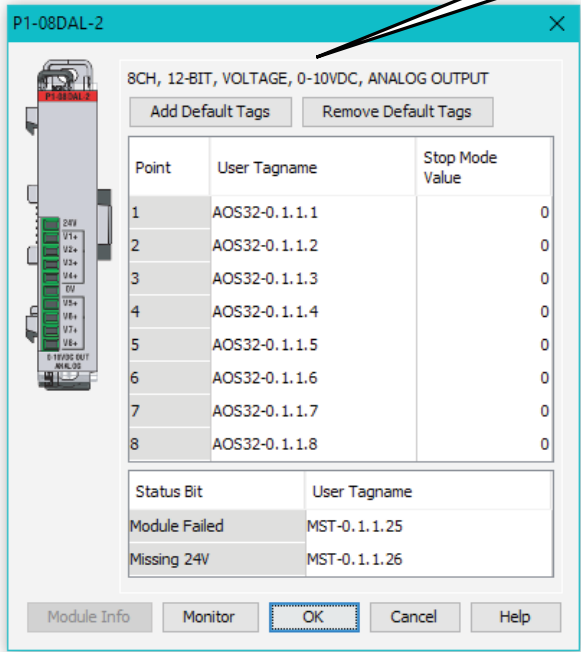

# P1-4ADL2DAL-1 Current Analog Input/Output

The P1-4ADL2DAL-1 Current Analog Input/Output Module provides four 13-bit input channels of 0–20 mA inputs and two 12-bit output channels at 4–20 mA for use with the Productivity®1000 system.

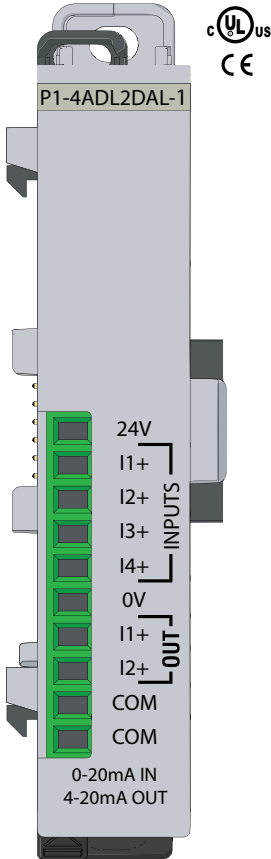

| Input Specifications                            |   |
|---|---|
| Inputs per Module                               | 4   |
| Module Signal Input Range                       | 0–20 mA   |
| Signal Resolution                               | 13-bit  |
| Resolution Value of LSB (least significant bit) | 0–20 mA = 2.44 $\mu$ A per count (1 LSB = 1 count)  |
| Data Range                                      | 0–8191 counts                                       |
| Input Type                                      | Sinking, single ended (1 common)                    |
| Maximum Continuous Overload                     | $\pm$ 31mA  |
| Input Impedance                                 | 247 $\Omega$ $\pm$ 0.5%, 1/4 W current input        |
| Filter Characteristics                          | Low pass, -3dB @ 120Hz                              |
| Sample Duration Time                            | 4ms per channel (does not include ladder scan time) |
| All Channel Update Rate                         | 20ms  |
| Open Circuit Detection Time                     | Zero reading within 100ms                           |
| Conversion Method                               | Successive approximation                            |
| Accuracy vs. Temperature                        | $\pm$ 75PPM/ $^{\circ}$ C maximum                   |
| Maximum Inaccuracy                              | 0.5% of range (including temperature drift)         |
| Linearity Error (end to end)                    | 0.037% of range<br>Monotonic with no missing codes  |
| Input Stability and Repeatability               | $\pm$ 0.024% of range (after 10 minute warm-up)     |
| Maximum Full Scale Calibration Error            | $\pm$ 0.098% of range                               |
| Offset Calibration Error                        | $\pm$ 0.098% of range                               |
| Maximum Crosstalk at DC, 50Hz and 60Hz          | 0.049% of range                                     |
| Recommended Fuse (external)                     | Edison S500-32-R, 0.032 A fuse                      |
| External Power Supply Required                  | 24VDC (-20% / +25%), 140mA (Loop power included)    |

Terminal block sold separately.

We recommend using pre-wired ZIPLink cables and connection modules. See Chapter 5. If you wish to hand-wire your module, removable terminal blocks are sold separately. Order part number P1-10RTB or P1-10RTB-1



## P1-4ADL2DAL-1 Current Analog Input/Output (cont'd)

| Output Specifications                           |  |
|---|--|
| Output Channels                                 | 2  |
| Module Signal Output Range                      | 4–20 mA  |
| Output Signal Resolution                        | 12-bit   |
| Resolution Value of LSB (least significant bit) | 4–20 mA = 3.9 $\mu$ A / count; 1 LSB = 1 count   |
| Data Range                                      | 0–4095 counts  |
| Output Type                                     | Current sourcing at 20mA max   |
| Output Value in Fault Mode                      | Less than 4mA  |
| Load Impedance (Minimum External Power Supply)  | 0–570 $\Omega$ (19.2 VDC)<br>0–690 $\Omega$ (21.6 VDC)<br>0–810 $\Omega$ (24.0 VDC)<br>0–930 $\Omega$ (26.4 VDC)<br>0–1100 $\Omega$ (30VDC); Minimum load: 0 $\Omega$ @ 0–45°C,<br>125 $\Omega$ @45–60°C ambient temperature |
| Maximum Inductive Load                          | 1mH  |
| Allowed Load Type                               | Grounded   |
| Maximum Inaccuracy                              | 1% of range  |
| Full Scale Calibration Error                    | $\pm$ 0.2% of range minimum  |
| Offset Calibration Error                        | $\pm$ 0.2% of range minimum  |
| Accuracy vs. Temperature                        | $\pm$ 75 PPM/°C max full scale calibration change ( $\pm$ 0.005% of range/°C)  |
| Max Crosstalk                                   | -72dB, 1 LSB   |
| Linearity Error (End to End)                    | $\pm$ 4 counts max. ( $\pm$ 0.1% of full scale)  |
| Output Stability and Repeatability              | $\pm$ 2% counts max. after 10 minute warm-up (typical)   |
| Output Ripple                                   | 0.2% of full scale   |
| Output Settling Time                            | 0.3 ms max., 5 $\mu$ s min. (full scale range)   |
| All Channel Update Rate                         | 4ms (max)  |
| Maximum Continuous Overload                     | Outputs open circuit protected   |
| Type of Output Protection                       | Electronically current limited to 20mA or less   |
| Output Signal (power-up, -down)                 | 4mA  |

| Removable Terminal Block Specifications |   |   |
|---|---|---|
| Part Number                             | P1-10RTB  | P1-10RTB-1  |
| Number of positions                     | 10 screw terminals  | 10 spring clamp terminals   |
| Wire Range                              | 30–16 AWG (0.051–1.31 mm <sup>2</sup> )<br>Solid/stranded conductor<br>3/64 in. (1.2 mm) insulation max.<br>1/4 in (6– 7 mm) strip length | 28–16 AWG (0.081–1.31 mm <sup>2</sup> )<br>Solid/stranded conductor<br>3/64 in (1.2 mm) insulation max.<br>19/64 in (7–8 mm) strip length |
| Conductors                              | USE COPPER CONDUCTORS, 75°C or equivalent.  |   |
| Screw Driver                            | 0.1 in (2.5 mm) maximum*  |   |
| Screw Size                              | M2  | N/A   |
| Screw Torque                            | 2.5 lb·in (0.28 N·m)  | N/A   |

\* Recommended screw driver P/N: TW-SD-MSL-1.

## P1-4ADL2DAL-1 Current Analog Input/Output (cont'd)

| General Specifications          |  |
|---------------------------------|--|
| Operating Temperature           | 0°C– 60°C (32°F–140°F)   |
| Storage Temperature             | -20°C–70°C (-4°F–158°F)  |
| Humidity                        | 5 to 95% (non-condensing)  |
| Altitude                        | 2,000 meters, max.   |
| Pollution Degree                | 2  |
| Environmental Air               | No corrosive gases permitted   |
| Vibration                       | IEC60068-2-6 (Test Fc)   |
| Shock                           | IEC60068-2-27 (Test Ea)  |
| Field to Logic Side Isolation   | 1800VAC applied for 1s   |
| Insulation Resistance           | > 10MΩ @ 500VDC  |
| Heat Dissipation                | 2470mW   |
| Oversoltage Category            | II   |
| Enclosure Type                  | Open equipment   |
| Module Location                 | Any I/O position in a Productivity@1000 system   |
| Field Wiring                    | Removable terminal block (sold separately). Use ZIPLink wiring system, optional<br>See "Wiring Options" in Chapter 5.          |
| Terminal Type (sold separately) | 10-position removable terminal block   |
| Weight                          | 60g (2.1 oz)   |
| Agency Approvals                | UL 61010-1 and UL 61010-2-201 File E139594,<br>Canada and USA<br>CE (EN 61131-2 EMC, EN 61010-1 and<br>EN 61010-2-201 Safety)* |

\* See CE Declaration of Conformance for details.

# P1-4ADL2DAL-1 Current Analog Input/Output (cont'd)

## Wiring Diagrams

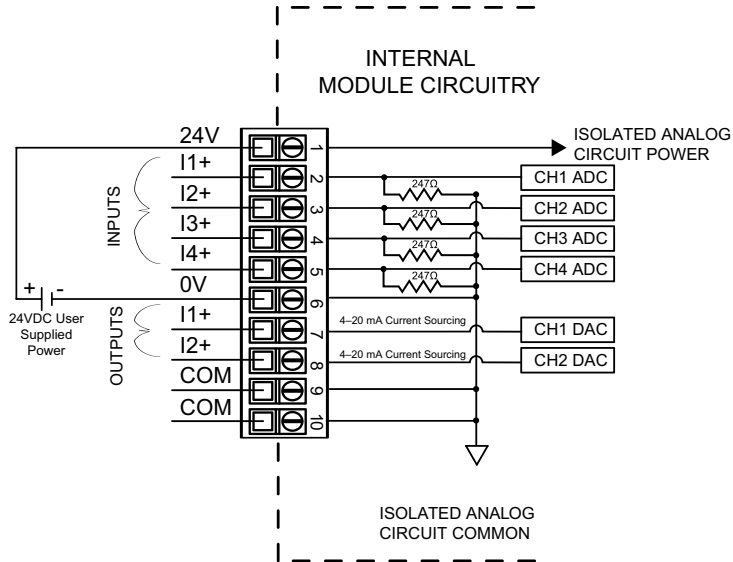

### Current Input Circuits

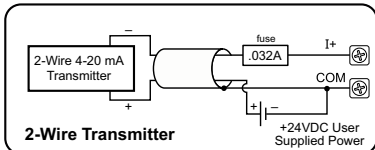

An Edison S500-32-R 0.032A fast-acting fuse is recommended for all 4-20 mA current loops.

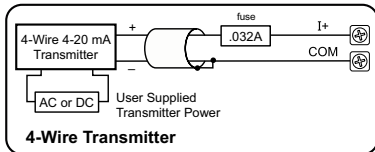
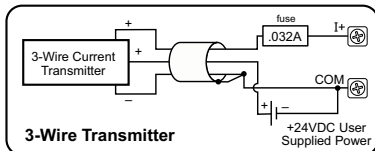

Note: Do not connect both ends of shield.

### Current Output Circuits

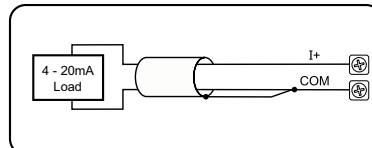

Note: Shield is connected to common at the source device.

# P1-4ADL2DAL-1 Current Analog Input/Output (cont'd)

## Module Configuration

Using the Hardware Configuration tool in the Productivity Suite programming software, drag and drop the P1-4ADL2DAL-1 module into the configuration.

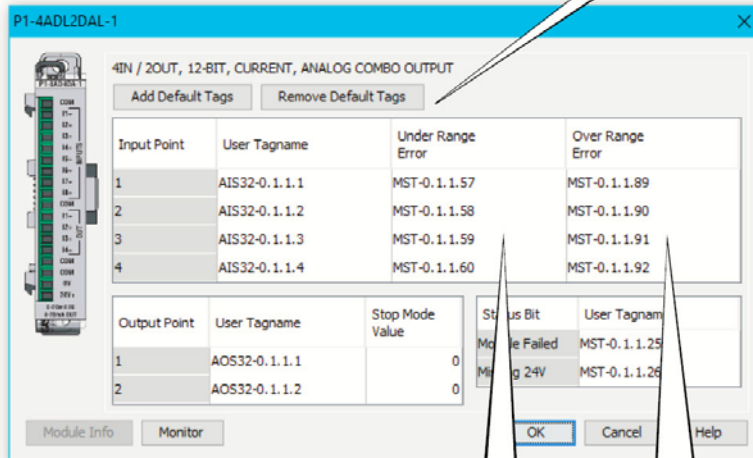

The "Under Range Error" bit for each channel activates for a signal around  $0\text{mA} \pm \text{offset error}$ .  
 The "Over Range Error" bit for each channel activates for a signal around  $19.999\text{ mA} \pm \text{gain error}$ .

# P1-4ADL2DAL-2 Voltage Analog Input/Output

The P1-4ADL2DAL-2 Voltage Analog Input/Output Module provides four 13-bit input channels at 0–10 VDC and two 12-bit output channels at 0–10 VDC for use with Productivity@1000 system.

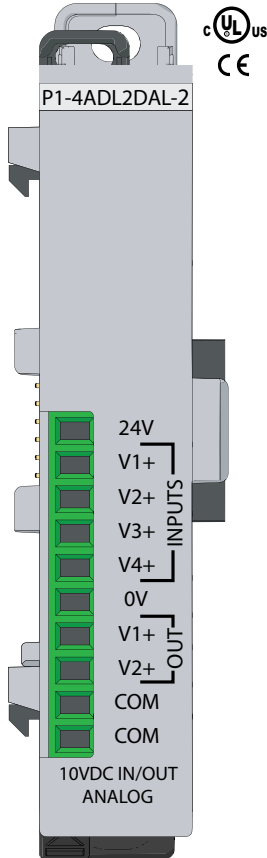

| Input Specifications                                |  |
|---|--|
| Input Channels                                      | 4  |
| Module Signal Input Range                           | 0–10 VDC   |
| Signal Resolution                                   | 13-bit   |
| Resolution Value of LSB (least significant bit)     | 0–10 VDC = 1.22 mV per count<br>(1 LSB = 1 count)      |
| Data Range  | 0–8191 counts  |
| Input Type  | Single Ended (1 common)                                |
| Maximum Continuous Overload                         | ±100VDC  |
| Input Impedance                                     | 200kΩ  |
| Filter Characteristics                              | Low pass, -3dB @ 100Hz                                 |
| Signal Duration Time                                | 4ms per channel<br>(does not include ladder scan time) |
| All Channel Update Rate                             | 20ms   |
| Conversion Method                                   | Successive approximation                               |
| Accuracy vs. Temperature                            | ±75PPM/°C maximum                                      |
| Maximum Inaccuracy                                  | 0.5% of range (including temperature drift)            |
| Linearity Error                                     | ±0.036% of range<br>Monotonic with no missing codes    |
| Input Stability and Repeatability                   | ±0.03% of range  |
| Full Scale Calibration Error (not including offset) | ±0.097% of range                                       |
| Offset Calibration Error                            | ±0.097% of range                                       |
| Maximum Crosstalk at DC, 50Hz and 60Hz              | ±0.049% of range                                       |
| External Power Supply Required                      | 24VDC (-20% / +25%), 100mA                             |

Terminal blocks sold separately.

We recommend using pre-wired ZIPLink cables and connection modules. See Chapter 5. If you wish to hand-wire your module, removable terminal blocks are sold separately. Order part number P1-10RTB or P1-10RTB-1



| Diagnosis/Status  |                   |
|-------------------|-------------------|
| Under Range Error | 1 bit per channel |
| Over Range Error  | 1 bit per channel |
| Module Failed     | 1 bit per module  |
| Missing 24V       | 1 bit per module  |

# P1-4ADL2DAL-2 Voltage Analog Input/Output (cont'd)

| Output Specifications                           |   |
|---|---|
| Output Channels                                 | 2   |
| Module Signal Output Range                      | 0–10 VDC  |
| Output Signal Resolution                        | 12-bit  |
| Resolution Value of LSB (least significant bit) | 0–10 VDC = 2.44 mV / count; 1 LSB= 1 count  |
| Data Range                                      | 0–4095 counts   |
| Output Type                                     | Voltage @10mA   |
| Output Value in Fault Mode                      | 0V  |
| Load Impedance                                  | ≥1000Ω  |
| Maximum Inductive Load                          | 0.01 μF   |
| Allowed Load Type                               | Grounded  |
| Maximum Inaccuracy                              | 0.5% of range   |
| Full Scale Calibration Error                    | ±0.2% of range  |
| Offset Calibration Error                        | ±0.2% of range  |
| Accuracy vs. Temperature                        | ±75PPM/°C max full-scale calibration change (±0.0025% of range/°C)  |
| Max Crosstalk                                   | -72dB, 1 LSB  |
| Linearity Error (End to End)                    | ±4 LSB max. (±0.1% of full scale)<br>Monotonic with not missing codes                                       |
| Output Stability and Repeatability              | ±2% LSB after 10 minute warm-up (typical)   |
| Output Ripple                                   | ±0.2% of full scale   |
| Output Settling Time                            | 0.3 ms max., 5μs min. (full scale range)  |
| All Channel Update Rate                         | 4ms   |
| Maximum Continuous Overload                     | Outputs open circuit limited to 40mA typical Continuous overloads on multiple outputs can damage the module |
| Type of Output Protection                       | 0.1 μs Transient Suppressor   |
| Output Signal at Power-up and Power-down        | 0V  |

| Removable Terminal Block Specifications |   |   |
|---|---|---|
| Part Number                             | P1-10RTB  | P1-10RTB-1  |
| Number of positions                     | 10 screw terminals  | 10 spring clamp terminals   |
| Wire Range                              | 30–16 AWG (0.051–1.31 mm <sup>2</sup> )<br>Solid/stranded conductor<br>3/64 in. (1.2 mm) insulation max.<br>1/4 in (6– 7 mm) strip length | 28–16 AWG (0.081–1.31 mm <sup>2</sup> )<br>Solid/stranded conductor<br>3/64 in (1.2 mm) insulation max.<br>19/64 in (7–8 mm) strip length |
| Conductors                              | USE COPPER CONDUCTORS, 75°C or equivalent.  |   |
| Screw Driver                            | 0.1 in (2.5 mm) maximum*  |   |
| Screw Size                              | M2  | N/A   |
| Screw Torque                            | 2.5 lb-in (0.28 N-m)  | N/A   |

\* Recommended screw driver P/N: TW-SD-MSL-1.

## P1-4ADL2DAL-2 Voltage Analog Input/Output (cont'd)

| General Specifications        |  |
|-------------------------------|--|
| Operating Temperature         | 0°C– 60°C (32°F–140°F)   |
| Storage Temperature           | -20°C–70°C (-4°F–158°F)  |
| Humidity                      | 5 to 95% (non-condensing)  |
| Altitude                      | 2000 meter max.  |
| Pollution Degree              | 2  |
| Environmental Air             | No corrosive gases permitted   |
| Vibration                     | IEC60068-2-6 (Test Fc)   |
| Shock                         | IEC60068-2-27 (Test Ea)  |
| Field to Logic Side Isolation | 1800VAC applied for 1s   |
| Insulation Resistance         | > 10MΩ @ 500VDC  |
| Heat Dissipation              | 1950mW   |
| Overvoltage Category          | II   |
| Enclosure Type                | Open equipment   |
| Module Location               | Any I/O slot in a Productivity®1000 system   |
| Field Wiring                  | Use ZIPLink wiring system or removable terminal block (not included). See "Wiring Options" in Chapter 5. |
| Connector Type (Not included) | 10-position removable terminal block   |
| Weight                        | 60g (2.1 oz)   |
| Agency Approvals              | UL61010-2-201 File E139594, Canada & USA<br>CE (EN61131-2 EMC and EN61010-2-201 Safety)*                 |

\* See CE Declaration of Conformance for details.

# P1-4ADL2DAL-2 Voltage Analog Input/Output (cont'd)

## Wiring Diagrams

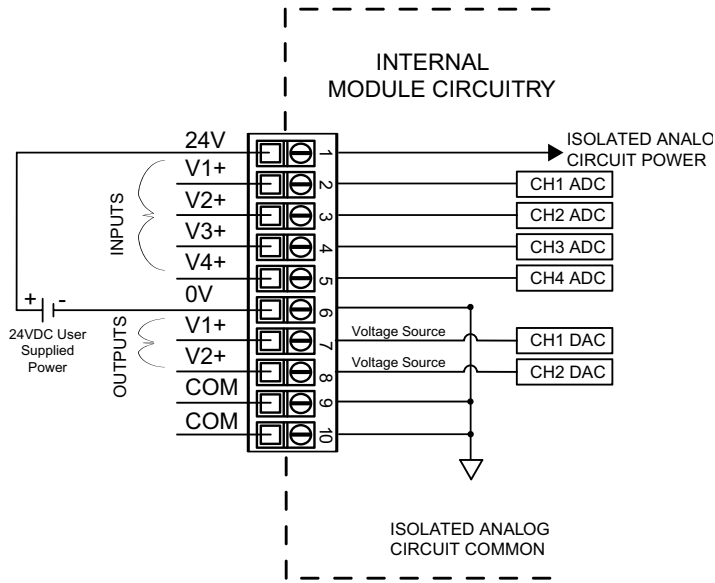

### Voltage Input Circuits

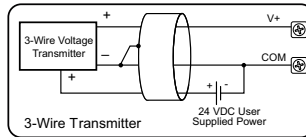
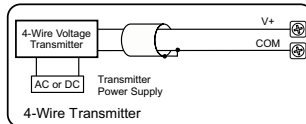

### Voltage Output Circuits

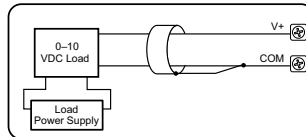

Notes for maximum accuracy:  
1. Jumper unused inputs to common.



# P1-4ADL2DAL-2 Voltage Analog Input/Output (cont'd)

## Module Configuration

Using the Hardware Configuration tool in the Productivity Suite programming software, drag and drop the P1-4ADL2DAL-2 module into the configuration.  
If desired, assign a *User Tagname* to each input point (channel) selected and to each *Status Bit Item*.

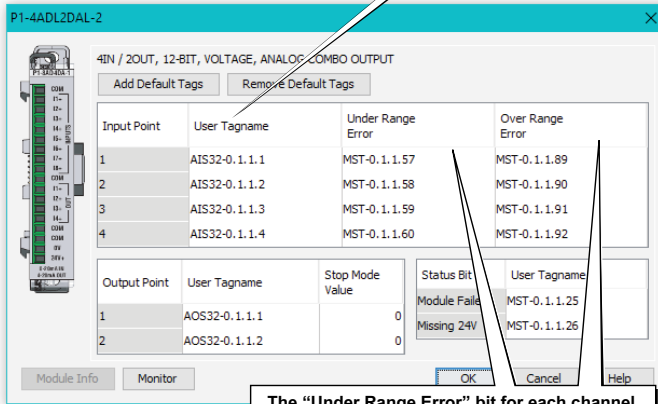

The "Under Range Error" bit for each channel activates for a signal around 0V, ± offset error.  
The "Over Range Error" bit for each channel activates for a signal around 10V, ± gain error.

# SPECIALTY MODULES SPECIFICATIONS

---



## In This Chapter...

|  |      |
|--|------|
| Specialty Modules Overview.....                          | 4-2  |
| P1-02HSC High-Speed Isolated Sinking/Sourcing Input..... | 4-3  |
| Wiring Diagrams.....                                     | 4-5  |
| Wiring Example for Koyo Totem Pole Output Encoder.....   | 4-7  |
| Module Configuration.....                                | 4-8  |
| P1-04PWM Module.....                                     | 4-9  |
| Wiring Diagrams.....                                     | 4-11 |
| Module Configuration.....                                | 4-12 |
| High-Speed Module Tester Utility.....                    | 4-13 |

## Specialty Modules Overview

Two specialty I/O modules are available for use with the Productivity®1000 system, the P1-02HSC High-Speed Input Module and the P1-04PWM Pulse Width Modulation module.

Each I/O module is identified as either an “Input” or “Output” module on its front panel using the color coding scheme listed below. The specifications and wiring diagrams, along with configuration and signal information, are in this chapter.

The P1-02HSC High-Speed Counter module provides two independent single-ended 5-24 V inputs that accept up to 100kHz of pulse/direction and quadrature signals. Additionally, two 5-24 VDC general purpose high-speed inputs are included for use with the Productivity®1000 system.

The P1-04PWM pulse Width Modulation module provides four channels of sinking or sourcing 0–20 kHz, 0–100% duty cycle outputs.

Use the hardware configuration tool in the Productivity Suite programming software to set up the specialty I/O modules. See the Productivity Suite software help file for in-depth configuration and programming concepts.

For applications that require specialized motion control, consider including a PS-AMC module.

**High-Speed Input Modules**

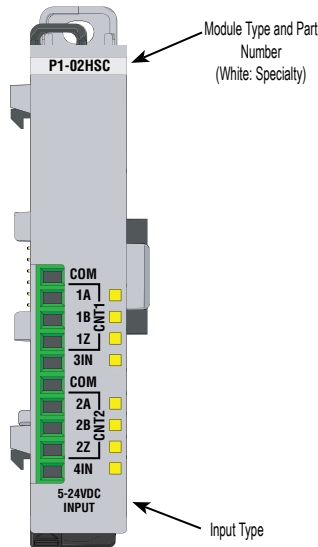

**Pulse Width Modulation**

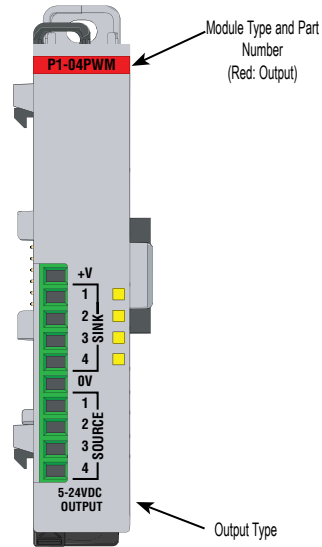

### Productivity1000 Specialty I/O Modules

| Part Number | Number of Channels | Description                            | See Page |
|-------------|--------------------|--|----------|
| P1-02HSC    | 2                  | High-Speed Input (Current)             | 4–3      |
| P1-04PWM    | 4                  | Pulse-Width Modulation Input (Voltage) | 4–9      |

# P1-02HSC High-Speed Isolated Sinking/Sourcing Input

The P1-02HSC High-Speed Counter Module provides two independent single-ended 5–24 VDC inputs that accept up to 100kHz of pulse/direction and quadrature signals. Additionally, two 5–24 VDC general-purpose high-speed inputs are included for use with the Productivity®1000 system.

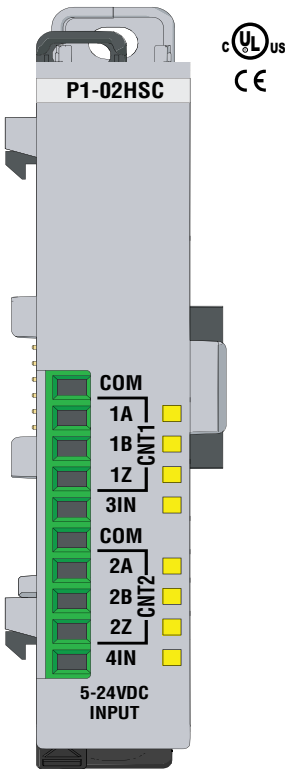

| Input Specifications          |   |
|-------------------------------|---|
| Inputs per Module             | Single ended Counter Inputs (6pts: 1A, 1B, 1Z, 2A, 2B, 2Z)<br>General-purpose Inputs (3IN, 4IN) |
| Input Voltage Range           | 5–24 VDC  |
| Operating Voltage Range       | 4.25–27.6 VDC   |
| Input Current                 | 1.5 mA typical @ 4.25 VDC<br>11mA maximum @ 27.6 VDC  |
| Input Impedance               | 2.5 kΩ  |
| Minimum ON Current            | 1mA   |
| Maximum OFF Current           | 0.4 mA  |
| Minimum ON Voltage            | 4.5 VDC   |
| Maximum OFF Voltage           | 2.2 VDC   |
| OFF to ON, ON to OFF Response | 2μs   |
| Maximum Input Frequency       | 100kHz  |
| Module Range                  | Target position range ±2.147 billion<br>(32-bit signed integer)                                 |
| Status Indicators Logic Side  | 8 points  |
| Commons                       | 2 (4 points/common)   |

\* Meets EMC and Safety requirements. See the D.O.C. for details.

Terminal Block sold separately.



**NOTE:** For complete system limits, please refer to the "Hardware and Communication Limits" table in the Productivity Suite online "Help" file "Hardware Configuration", topic P050.

We recommend using pre-wired ZIPLink cables and connection modules. See Chapter 5. If you wish to hand-wire your module, removable terminal blocks are sold separately. Order part number P1-10RTB or P1-10RTB-1



# P1-02HSC High-Speed Isolated Sinking/Sourcing Input (continued)

| General Specifications          |   |
|---------------------------------|---|
| Operating Temperature           | 0°C–60°C (32°F–140°F)   |
| I/O Points Used                 | None, mapped directly to tags in CPU  |
| Storage Temperature             | -20°C–70°C (-4°F–158°F)   |
| Humidity                        | 5 to 95% (non-condensing)   |
| Environmental Air               | No corrosive gases permitted  |
| Altitude                        | 2,000 meters max.   |
| Pollution Degree                | 2   |
| Vibration                       | IEC 60068-2-6 (Test Fc)   |
| Shock                           | IEC 60068-2-27 (Test Ea)  |
| Overvoltage Category            | II  |
| Field to Logic Side Isolation   | 1800VAC applied for 1s  |
| Insulation Resistance           | >10MΩ @ 500VDC  |
| Heat Dissipation                | 1300mW  |
| Field Wiring                    | Use ZIPLink wiring system.<br>See "Wiring Options" in Chapter 5.  |
| Terminal Type (sold separately) | 10-position Removable Terminal Block  |
| Weight                          | 54g (2oz)   |
| Agency Approvals                | UL 61010-1 and UL 61010-2-201 File E139594, Canada and USA<br>CE (EN 61131-2 EMC, EN 61010-1 and EN 61010-2-201 Safety)** |

*\*Note: For complete system limits, please refer to the "Hardware and Communication Limits" table in the Productivity Suite Help File, "Hardware Configuration" topic (P050).  
\*\*Meets EMC and Safety Requirements. See the D.O.C. for details.*

| Removable Terminal Block Specifications |   |   |
|---|---|---|
| Part Number                             | P1-10RTB  | P1-10RTB-1  |
| Number of positions                     | 10 screw terminals  | 10 spring clamp terminals   |
| Wire Range                              | 30–16 AWG (0.051–1.31 mm <sup>2</sup> )<br>Solid/stranded conductor<br>3/64 in. (1.2 mm) insulation max.<br>1/4 in (6– 7 mm) strip length | 28–16 AWG (0.081–1.31 mm <sup>2</sup> )<br>Solid/stranded conductor<br>3/64 in (1.2 mm) insulation max.<br>19/64 in (7–8 mm) strip length |
| Conductors                              | USE COPPER CONDUCTORS, 75°C or equivalent.  |   |
| Screw Driver                            | 0.1 in (2.5 mm) maximum*  |   |
| Screw Size                              | M2  | N/A   |
| Screw Torque                            | 2.5 lb-in (0.28 N·m)  | N/A   |

\* Recommended screw driver P/N: TW-SD-MSL-1.

# P1-02HSC High-Speed Isolated Sinking/Sourcing Input (continued)

## Wiring Diagrams

### High Speed General Purpose Inputs

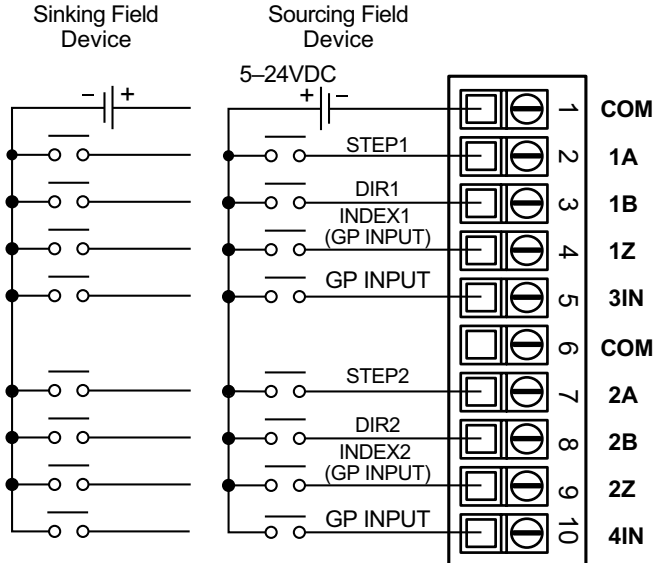

### Equivalent Input Circuit

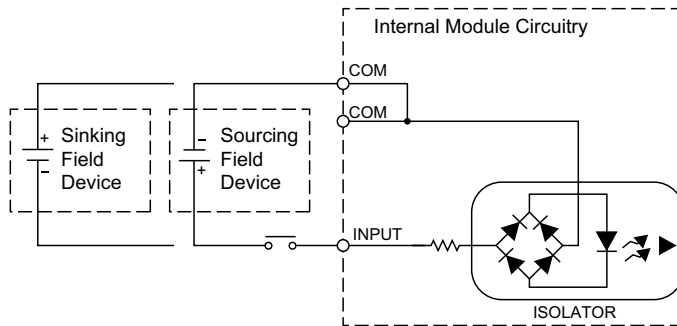

# P1-02HSC High-Speed Isolated Sinking/Sourcing Input (continued)

## Wiring Example for Koyo Open Collector Output Encoder

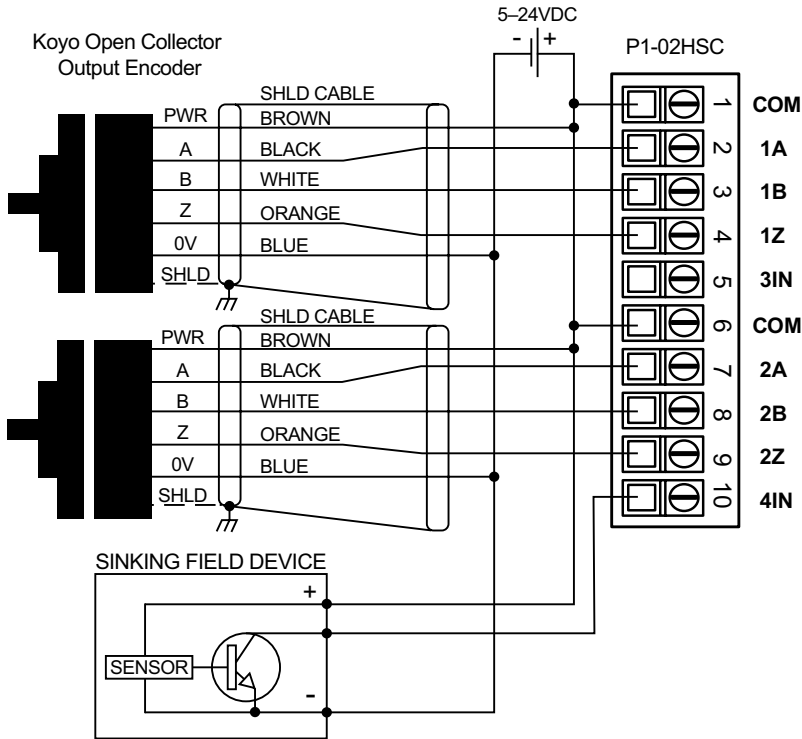

Line Driver Output Encoders Not Recommended for P1-02HSC

# P1-02HSC High-Speed Isolated Sinking/Sourcing Input (continued)

## Wiring Example for Koyo Totem Pole Output Encoder

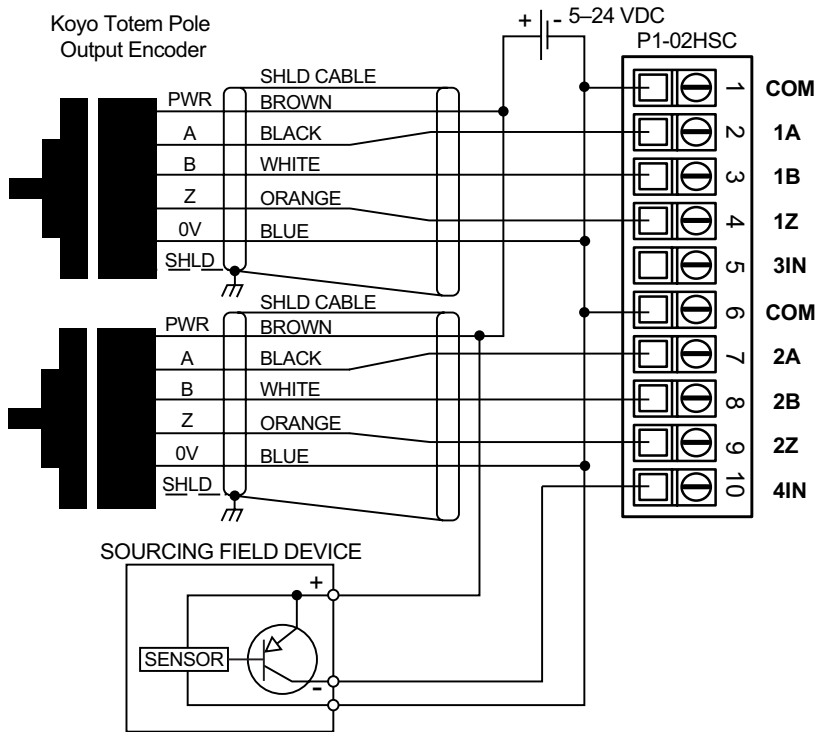

# P1-02HSC High-Speed Isolated Sinking/ Sourcing Input (continued)

## Module Configuration

Using the Hardware Configuration tool in the Productivity Suite programming software, drag and drop the P1-02HSC module into the base configuration.  
If desired, assign a *User Tagname* to each output point channel selected. A *Stop Mode Value* may also be assigned.

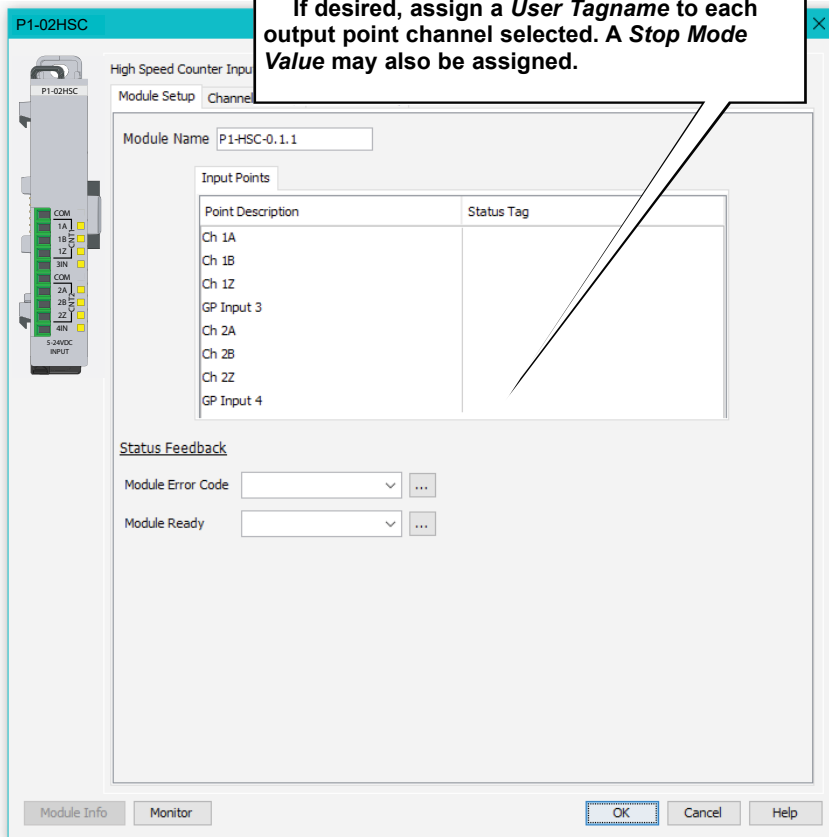

# P1-04PWM Module

The P1-04PWM pulse width modulation module provides four channels of sinking or sourcing 0–20 kHz, 0–100% duty cycle outputs for use with the Productivity®1000 system.

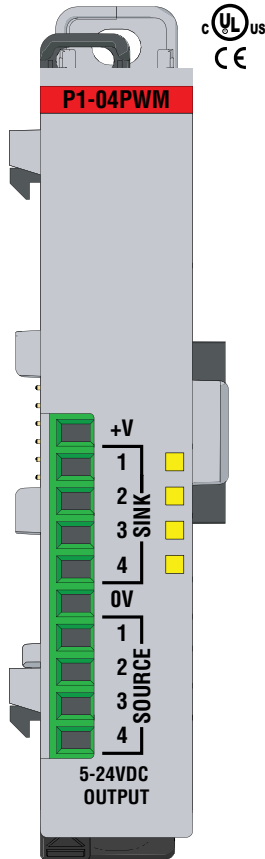

Terminal Block sold separately.

We recommend using pre-wired ZIPLink cables and connection modules. See Chapter 5. If you wish to hand-wire your module, removable terminal blocks are sold separately. Order part number P1-10RTB or P1-10RTB-1



| Output Specifications                       |  |                                   |
|---|--|-----------------------------------|
| Outputs per Module                          | 4 PWM outputs  |                                   |
| Output Type                                 | Open drain N-CH MOSFET (sinking)   | Open drain P-CH MOSFET (sourcing) |
| Rated Voltage                               | 5–24 V   |                                   |
| Operating Voltage Range                     | 4.75–28.8 VDC  |                                   |
| Maximum Output Current                      | Only Sinking Load<br>Only Sourcing Load<br>Both Sinking and Sourcing Loads | 0mA<br>200mA<br>100mA             |
| Minimum Load Current                        | 5mA @ 5V   |                                   |
| Maximum Leakage Current                     | 0.1 mA @ 28.8  |                                   |
| On Voltage Drop                             | 0.8 VDC @ 200mA  | 1.2 V @ 200mA                     |
| Maximum Inrush Current                      | 500mA for 50ms   |                                   |
| Maximum Frequency Inaccuracy                | 0.5% of range  |                                   |
| Maximum Duty Cycle Inaccuracy               | 0.6% of range below 10kHz<br>1.2% of range 10–20 kHz                       |                                   |
| Maximum Load Resistance for Stated Accuracy | 1kΩ  |                                   |
| Accuracy vs. Temperature                    | ±50PPM max.  |                                   |
| Start/Stop PWM Response                     | 0.5 ms   |                                   |
| PWM Frequency                               | 0–20 kHz   |                                   |
| PWM Duty Cycle                              | 0–100% below 10kHz<br>5–95% 10–20 kHz                                      |                                   |
| Status Indicators                           | Logic Side 4 points  |                                   |
| Commons                                     | 1 non-isolated   |                                   |
| Maximum Applicable Fuses                    | 1A   |                                   |
| External Power Supply Required              | 5–24 VDC @ 40mA, Class 2   |                                   |

| Power Specifications   |        |
|--|--------|
| Maximum Voltage  | 28.8 V |
| Minimum Voltage  | 4.75 V |
| Current Consumption Excluding Outputs                            | 40mA   |
| Maximum Current Consumption Total for 4 sink or 4 source Outputs | 800mA  |

Warranty: Thirty-day money-back guarantee.  
Two-year limited replacement.  
(See [www.productivity1000.com](http://www.productivity1000.com) for details.)

# P1-04PWM Module Overview (continued)

| General Specifications          |  |
|---------------------------------|--|
| Operating Temperature           | 0°C–60°C (32°F–140°F)  |
| Storage Temperature             | -20°C–70°C (-4°F–158°F)  |
| Humidity                        | 5 to 95% (non-condensing)  |
| Environmental Air               | No corrosive gases permitted   |
| Vibration                       | IEC 60068-2-6 (Test Fc)  |
| Shock                           | IEC 60068-2-27 (Test Ea)   |
| Field to Logic Side Isolation   | 1800VAC applied for 1s   |
| Insulation Resistance           | >10MΩ @ 500VDC   |
| Heat Dissipation                | 1400mW   |
| Enclosure Type                  | Open equipment   |
| Module Location                 | Any I/O location in a Productivity@1000 system   |
| Field Wiring                    | Removable terminal block (sold separately). Use <b>ZIPLink</b> wiring system. See "Wiring Options" in Chapter 5.         |
| Terminal Type (Sold Separately) | 10-position removable terminal block   |
| Weight                          | 56g (2oz)  |
| Agency Approvals                | UL 61010-1 and UL 61010-2-201 File E139594, Canada and USA<br>CE (EN 61131-2 EMC, EN 61010-1 and EN 61010-2-201 Safety)* |

\* See CE Declaration of Conformance for details.

| Removable Terminal Block Specifications |   |   |
|---|---|---|
| Part Number                             | P1-10RTB  | P1-10RTB-1  |
| Number of positions                     | 10 screw terminals  | 10 spring clamp terminals   |
| Wire Range                              | 30–16 AWG (0.051–1.31 mm <sup>2</sup> )<br>Solid/stranded conductor<br>3/64 in. (1.2 mm) insulation max.<br>1/4 in (6– 7 mm) strip length | 28–16 AWG (0.081–1.31 mm <sup>2</sup> )<br>Solid/stranded conductor<br>3/64 in (1.2 mm) insulation max.<br>19/64 in (7–8 mm) strip length |
| Conductors                              | USE COPPER CONDUCTORS, 75°C or equivalent.  |   |
| Screw Driver                            | 0.1 in (2.5 mm) maximum*  |   |
| Screw Size                              | M2  | N/A   |
| Screw Torque                            | 2.5 lb·in (0.28 N·m)  | N/A   |

\* Recommended screw driver P/N: TW-SD-MSL-1.

# P1-04PWM Module Overview (continued)

## Wiring Diagrams

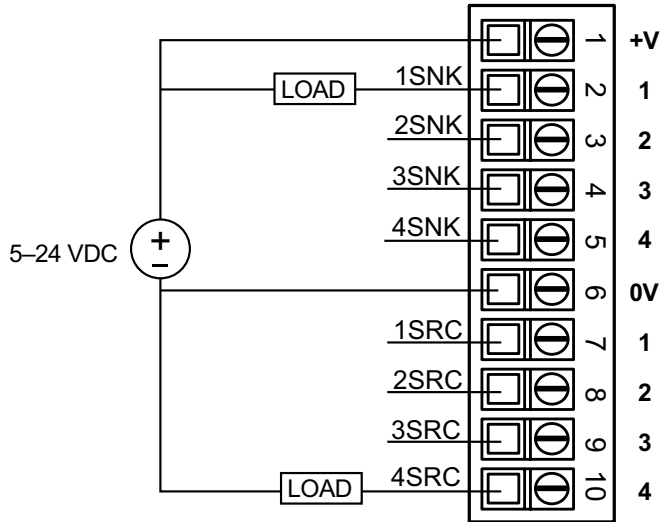

**NOTE:** Both channels (sinking/sourcing) output the same frequency and duty cycle that is assigned to the tag in Hardware Configuration window.

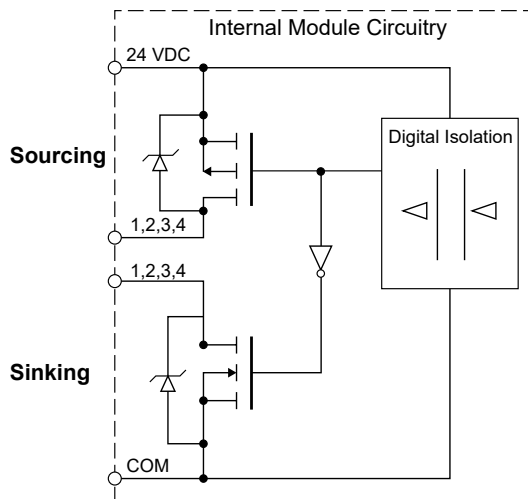

# P1-04PWM Module Overview (continued)

## Module Configuration

Using the Hardware Configuration tool in the Productivity Suite programming software, drag and drop the P1-04PWM module into the base configuration.

If desired, assign a *User Tagname* to each output point channel selected. A *Stop Mode Value* may also be assigned.

4CH, Pulse Width Modulation

Add Default Tags

| Point | Duty Cycle(%)<br>Tagname | Carrier Freq.(Hz)<br>Tagname | Output<br>Type | Duty Cycle<br>Implied<br>Decimal | Duty Cycle<br>Stop Mode<br>Value | Carrier Freq.(Hz)<br>Stop Mode Value |
|-------|--------------------------|------------------------------|----------------|----------------------------------|----------------------------------|--------------------------------------|
| 1     | AOS32-0.1.1.1            | AOS32-0.1.1.2                | PWM            | x 1                              | 0                                | 0                                    |
| 2     | AOS32-0.1.1.3            | AOS32-0.1.1.4                | PWM            | x 1                              | 0                                | 0                                    |
| 3     | AOS32-0.1.1.5            | AOS32-0.1.1.6                | PWM            | x 1                              | 0                                | 0                                    |
| 4     | AOS32-0.1.1.7            | AOS32-0.1.1.8                | PWM            | x 1                              | 0                                | 0                                    |

Status Bit: Module Failed

User Tagname: MST-0.1.1.25

Module Info Monitor OK Cancel Help

## High-Speed Module Tester Utility

The High-Speed Module Tester software utility allows a user to test the PS-AMC module's inputs and outputs. It is highly recommended that you simulate your PS-AMC functions before attempting to control the module from your CPU program. This software utility, seen below, can be useful with debugging, confirming field wiring and verifying external device operation.

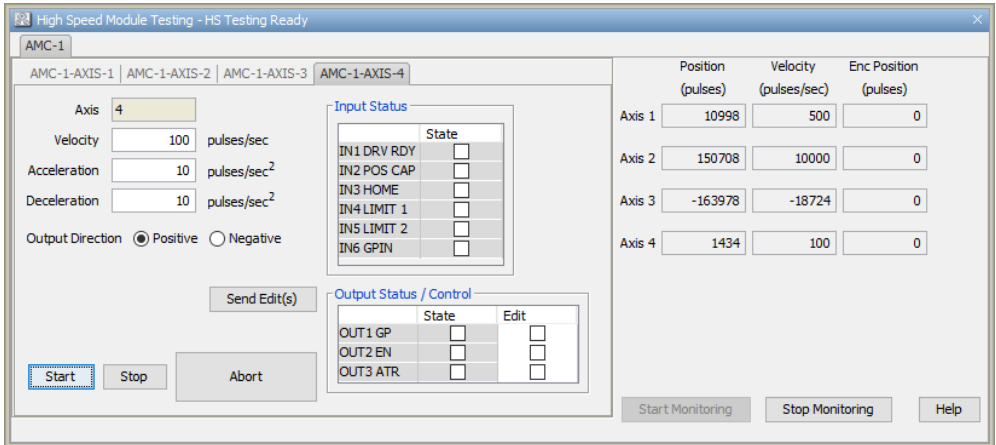

Refer to the Productivity Suite Help file for more information on the High-Speed Module Tester Utility.

# INSTALLATION AND WIRING

---



# CHAPTER 5

## In This Chapter...

|  |      |
|--|------|
| <b>Safety Guidelines</b> .....                   | 5-3  |
| Plan for Safety.....                             | 5-3  |
| Three Levels of Protection .....                 | 5-4  |
| Orderly System Shutdown .....                    | 5-4  |
| System Power Disconnect.....                     | 5-4  |
| Emergency Stop Circuits.....                     | 5-5  |
| <b>Productivity®1000 Mechanical Design</b> ..... | 5-6  |
| Typical Productivity1000 System .....            | 5-6  |
| <b>Dimensions and Installation</b> .....         | 5-7  |
| <b>Basic Dimensions</b> .....                    | 5-10 |
| P1-01AC, P1-02AC and P1-01DC Power Supplies..... | 5-10 |
| P1-412/ P1-540 /P1-550 /P1-622 CPUs .....        | 5-10 |
| P1-RX Module.....                                | 5-11 |
| I/O Modules.....                                 | 5-11 |
| P1-Mxxx PLC Modules.....                         | 5-12 |
| <b>Mounting Guidelines</b> .....                 | 5-13 |
| Enclosures.....                                  | 5-13 |
| Mounting Position.....                           | 5-13 |
| Using Mounting Rails.....                        | 5-13 |
| Mounting Clearances.....                         | 5-14 |
| Temperature Considerations.....                  | 5-14 |
| Power Considerations .....                       | 5-14 |
| Grounding .....                                  | 5-15 |
| Agency Approvals.....                            | 5-15 |
| Installing the Power Supply.....                 | 5-16 |

## Table of Contents

---

|   |             |
|---|-------------|
| DIN Rail Mounting P1000 System .....                            | 5-17        |
| Surface Mounting P1000 System .....                             | 5-17        |
| Installing the I/O Modules .....                                | 5-18        |
| <b>Wiring Guidelines .....</b>                                  | <b>5-19</b> |
| Power Supply Wiring .....                                       | 5-19        |
| Grounding .....   | 5-19        |
| Fuse Protection .....   | 5-20        |
| <b>I/O Module Wiring Options .....</b>                          | <b>5-21</b> |
| Hand Wiring System .....  | 5-21        |
| ZIPLink Wiring System .....                                     | 5-22        |
| Terminal Block With Pigtail Cable .....                         | 5-22        |
| Input and Output Modules ZIPLink Selections .....               | 5-23        |
| Analog Modules ZIPLink Selections .....                         | 5-24        |
| P1 Mini Series PLC Modules ZIPLink Selections .....             | 5-25        |
| Removable Terminal Blocks (Optional) .....                      | 5-26        |
| P1-10RTB and P1-10RTB-1 .....                                   | 5-26        |
| P2-RTB and P2-RTB-1 .....                                       | 5-26        |
| Terminal Block Installation .....                               | 5-27        |
| Terminal Block Removal .....                                    | 5-28        |
| Planning the I/O Wiring Routes .....                            | 5-28        |
| <b>System Wiring Strategies .....</b>                           | <b>5-29</b> |
| CPU Isolation Boundaries .....                                  | 5-29        |
| Sinking/Sourcing Concepts .....                                 | 5-30        |
| I/O "Common Terminal" Concepts .....                            | 5-31        |
| DC Input Wiring Methods .....                                   | 5-32        |
| DC Output Wiring Methods .....                                  | 5-32        |
| Relay Outputs - Wiring Methods .....                            | 5-34        |
| Relay Outputs – Transient Suppression for Inductive Loads ..... | 5-35        |
| CPU's Integrated Transient Suppressors .....                    | 5-36        |
| Types of Additional Transient Protection .....                  | 5-37        |

# Safety Guidelines



**NOTE:** Products with CE marks perform their required functions safely and adhere to relevant standards as specified by CE directives provided they are used according to their intended purpose and that the instructions in this manual are adhered to. The protection provided by the equipment may be impaired if this equipment is used in a manner not specified in this manual. A listing of our international affiliates is available on our Web site at <http://www.automationdirect.com>.



**WARNING:** Providing a safe operating environment for personnel and equipment is your responsibility and should be your primary goal during system planning and installation. Automation systems can fail and may result in situations that can cause serious injury to personnel or damage to equipment. Do not rely on the automation system alone to provide a safe operating environment. You should use external electromechanical devices, such as relays or limit switches, that are independent of the CPU application to provide protection for any part of the system that may cause personal injury or damage. Every automation application is different, so there may be special requirements for your particular application. Make sure you follow all national, state, and local government requirements for the proper installation and use of your equipment.

## Plan for Safety

The best way to provide a safe operating environment is to make personnel and equipment safety part of the planning process. You should examine every aspect of the system to determine which areas are critical to operator or machine safety. If you are not familiar with CPU system installation practices, or your company does not have established installation guidelines, you should obtain additional information from the following sources.

- NEMA — The National Electrical Manufacturers Association, located in Washington, D.C., publishes many different documents that discuss standards for industrial control systems. You can order these publications directly from NEMA. Some of these include:
  - ICS 1, General Standards for Industrial Control and Systems
  - ICS 3, Industrial Systems
  - ICS 6, Enclosures for Industrial Control Systems
- NEC — The National Electrical Code provides regulations concerning the installation and use of various types of electrical equipment. Copies of the NEC Handbook can often be obtained from your local electrical equipment distributor or your local library.
- Local and State Agencies — many local governments and state governments have additional requirements above and beyond those described in the NEC Handbook. Check with your local Electrical Inspector or Fire Marshall office for information.

### Three Levels of Protection



**WARNING:** The control program must not be the only form of protection for any problems that may result in a risk of personal injury or equipment damage.

The publications mentioned provide many ideas and requirements for system safety. At a minimum, you should follow these regulations. Also, you should use the following techniques, which provide three levels of system control.

1. Orderly system shutdown sequence in the CPU control program.
2. Mechanical disconnect for output module power.
3. Emergency stop switch for disconnecting system power.

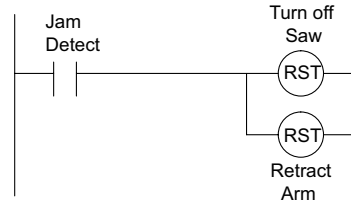
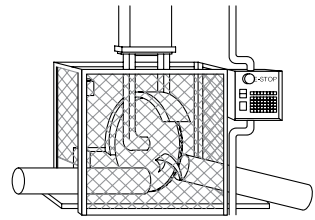

### Orderly System Shutdown

The first level of fault detection is ideally the CPU control program, which can identify machine problems. Certain shutdown sequences should be performed. These types of problems are usually things such as jammed parts, etc., that do not pose a risk of personal injury or equipment damage.

### System Power Disconnect

You should also use electromechanical devices, such as master control relays and/or limit switches, to prevent accidental equipment startup at an unexpected time. These devices should be installed in a manner that will prevent any machine operations from occurring.

For example, if the machine in the illustration has a jammed part, the CPU control program can turn off the saw blade and retract the arbor. If the operator must open the guard to remove the part, you should also include a bypass switch that disconnects all system power any time the guard is opened.

## Emergency Stop Circuits

Emergency stop (E-Stop) circuits are a critical part of automation safety. For each machine controlled by a CPU, provide an emergency stop device that is wired outside the CPU and easily accessed by the machine operator.

E-Stop devices are commonly wired through a master control relay (MCR) or a safety control relay (SCR) that will remove power from the CPU I/O system in an emergency.

MCRs and SCRs provide a convenient means for removing power from the I/O system during an emergency situation. By de-energizing an MCR (or SCR) coil, power to the input (optional) and output devices is removed. This event occurs when any emergency stop switch opens. However, the CPU continues to receive power and operate even though all its inputs and outputs are disabled.

The MCR circuit could be extended by placing a CPU fault relay (closed during normal CPU operation) in series with any other emergency stop conditions. This would cause the MCR circuit to drop the CPU I/O power in case of a CPU failure (memory error, I/O communications error, etc.).

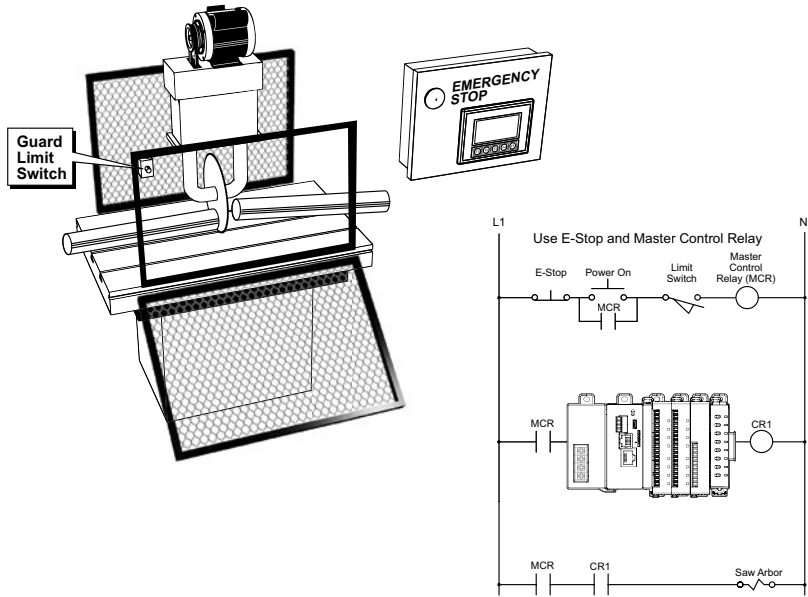

**WARNING:** For some applications, field device power may still be present on the terminal block even though the CPU is turned off. To minimize the risk of electrical shock, remove all field device power before you expose or remove CPU wiring.

# Productivity®1000 Mechanical Design

The Productivity1000 is a modular system requiring one CPU and up to 15 expansion I/O modules. Expansion modules are connected directly to the right side of the CPU and to each other in a continuous stack. Connect any I/O module combination to the right of the CPU without power budget or module type restrictions\*. No backplane or base is required. Each module connection extends the backbone communication bus. The system can be further expanded using the P1-RX module supporting up to eight expansion I/O modules.

## Typical Productivity1000 System

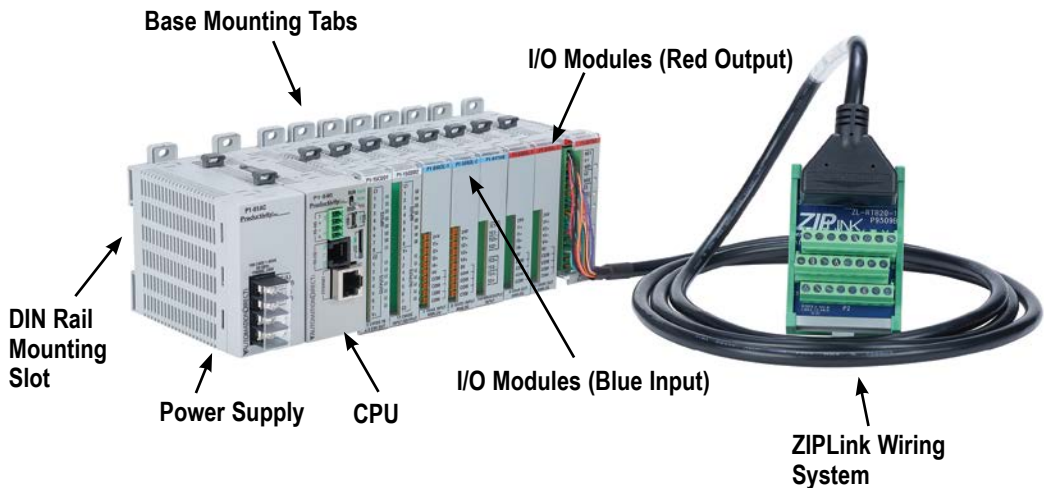

**\*NOTE:** P1-01AC or P1-01DC will power up to 8 modules, and the P1-02AC will power up to 15 modules.

## Dimensions and Installation

Before installing the CPU system you will need to know the dimensions of the components considered. The tables and diagrams on the following pages provide basic dimensions to use in defining your enclosure specifications. Remember to leave room for expansion module insertion and/or replacement and for potential expansion. If you are using other components in your system, refer to the appropriate manual to determine how those units can affect mounting dimensions.

The basic dimensions for the modules are listed in the tables. The width varies depending on the type of module. Productivity1000 is designed to be mounted on standard 35mm DIN rail, or it may be surface mounted. Make sure you have followed the installation guidelines for proper spacing.



**NOTE:** Dimensional drawings for the CPU, power supply and all modules are available on the [AutomationDirect.com](http://AutomationDirect.com) site.

| Productivity1000 Component Dimensions |                                  |                  |                                |                             |                  |
|---------------------------------------|----------------------------------|------------------|--------------------------------|-----------------------------|------------------|
| Module                                | Description                      | A                | B                              | C                           | D                |
|                                       |                                  | Width mm<br>[in] | Height<br>Faceplate<br>mm [in] | Height<br>w/Tabs<br>mm [in] | Depth<br>mm [in] |
| P1-412                                | CPU                              | 26.6<br>[1.05]   | 77.4<br>[3.03]                 | 92.8<br>[3.65]              | 91.6<br>[3.6]    |
| P1-540                                |                                  | 32.8<br>[1.29]   |                                |                             |                  |
| P1-550                                |                                  |                  |                                | 91.7<br>[3.61]              |                  |
| P1-622                                |                                  |                  |                                |                             |                  |
| P1-RX                                 | Remote I/O Module                | 23.1<br>[0.91]   | 77 [3.03]                      | 92.8<br>[3.65]              | 90.6<br>[3.57]   |
| P1-01AC                               | AC/DC Power Supply               | 35.0<br>[1.38]   | 77.0<br>[3.03]                 | 92.8<br>[3.65]              | 98.3<br>[3.87]   |
| P1-02AC                               | AC Power Supply                  | 52.2<br>[2.06]   |                                |                             |                  |
| P1-01DC                               | DC Power Supply                  | 35.0<br>[1.38]   |                                |                             |                  |
| Discrete Expansion Modules            |                                  |                  |                                |                             |                  |
| P1-08SIM                              | Simulator Input                  | 17.2<br>[0.68]   | 77.0<br>[3.03]                 | 93.6<br>[3.69]              | 86.6<br>[3.41]   |
| P1-08ND3                              | Sinking/Sourcing 12–24 VDC Input |                  |                                |                             |                  |
| P1-08ND-TTL                           | Sinking/Sourcing Input           |                  |                                |                             | 81.6<br>[3.21]   |
| P1-16ND3                              | Sinking/Sourcing 12–24 VDC Input |                  |                                |                             |                  |
| P1-08NE3                              | Sinking/Sourcing 12–24 VDC Input |                  |                                |                             | 86.6<br>[3.41]   |
| P1-16NE3                              | Sinking/Sourcing 12–24 VDC Input |                  |                                |                             |                  |
| P1-08NA                               | AC Isolated 100–240 VAC          |                  |                                |                             | 81.6<br>[3.21]   |
| P1-08TD-TTL                           | Sourcing Output                  |                  |                                |                             |                  |
| P1-08TD1                              | Sinking Output                   |                  |                                |                             | 86.6<br>[3.41]   |
| P1-08TD2                              | Sourcing Output                  |                  |                                |                             |                  |
| P1-15TD1                              | Sinking Output                   |                  |                                |                             |                  |
| P1-15TD2                              | Sourcing Output                  |                  |                                |                             |                  |

## Dimensions and Installation (cont'd)

| Productivity1000 I/O Modules Dimensions |  |                  |                                |                             |                  |
|---|--|------------------|--------------------------------|-----------------------------|------------------|
| Module                                  | Description                                  | A                | B                              | C                           | D                |
|   |  | Width mm<br>[in] | Height<br>Faceplate<br>mm [in] | Height<br>w/Tabs<br>mm [in] | Depth<br>mm [in] |
| P1-08TA                                 | AC Output                                    | 17.2<br>[0.68]   | 77.0<br>[3.03]                 | 93.6<br>[3.69]              | 86.6<br>[3.41]   |
| P1-08TRS                                | Isolated Relay Output                        | 26.3<br>[1.03]   |                                |                             |                  |
| P1-16TR                                 | Relay Output                                 |                  |                                |                             |                  |
| P1-15CDD1                               | Input: Sinking/Sourcing;<br>Output: Sinking  | 17.2<br>[0.68]   | 77.0<br>[3.03]                 | 93.6<br>[3.69]              | 86.6<br>[3.41]   |
| P1-15CDD2                               | Input: Sinking/Sourcing;<br>Output: Sourcing |                  |                                |                             |                  |
| P1-16CDR                                | Input: Sinking/Sourcing;<br>Output: Relay    |                  |                                |                             |                  |
| Analog Expansion Modules                |  |                  |                                |                             |                  |
| P1-04RTD                                | RTD Input                                    | 17.2<br>[0.68]   | 77.0<br>[3.03]                 | 93.6<br>[3.69]              | 81.6<br>[3.21]   |
| P1-04THM                                | Thermocouple Input                           |                  |                                |                             |                  |
| P1-04NTC                                | Thermistor Input                             |                  |                                |                             |                  |
| P1-04AD                                 | Analog Input (Current/Voltage)               |                  |                                |                             |                  |
| P1-04AD-1                               | Analog Input (Current)                       |                  |                                |                             |                  |
| P1-04AD-2                               | Analog Input (Voltage)                       |                  |                                |                             |                  |
| P1-04ADL-1                              | Analog Input (Current)                       | 17.2<br>[0.68]   | 77.0<br>[3.03]                 | 93.6<br>[3.69]              | 81.9<br>[3.22]   |
| P1-04ADL-2                              | Analog Input (Voltage)                       |                  |                                |                             |                  |
| P1-04DAL-1                              | Analog Output (Current)                      |                  |                                |                             |                  |
| P1-04DAL-2                              | Analog Output (Voltage)                      |                  |                                |                             |                  |
| P1-08ADL-1                              | Analog Input (Current)                       | 17.2<br>[0.68]   | 77.0<br>[3.03]                 | 93.6<br>[3.69]              | 81.6<br>[3.21]   |
| P1-08ADL-2                              | Analog Input (Voltage)                       |                  |                                |                             |                  |
| P1-08DAL-1                              | Analog Output (Current)                      |                  |                                |                             |                  |
| P1-08DAL-2                              | Analog Output (Voltage)                      |                  |                                |                             |                  |
| P1-4ADL2DAL-1                           | Analog Input/Analog Output<br>(Current)      |                  |                                |                             |                  |
| P1-4ADL2DAL-2                           | Analog Input/Analog Output<br>(Voltage)      |                  |                                |                             |                  |
| Specialty Expansion Modules             |  |                  |                                |                             |                  |
| P1-02HSC                                | High-Speed Input (Current)                   | 17.2<br>[0.68]   | 77.0<br>[3.03]                 | 93.6<br>[3.69]              | 81.6<br>[3.21]   |
| P1-04PWM                                | Pulse Width Modulation Input<br>(Voltage)    |                  |                                |                             |                  |

## Dimensions and Installation (cont'd)

| P1 Mini PLC Dimensions |  |                  |                                |                              |                  |
|------------------------|--|------------------|--------------------------------|------------------------------|------------------|
| Module                 | Description                                  | A                | B                              | C                            | D                |
|                        |  | Width mm<br>[in] | Height<br>Faceplate<br>mm [in] | Height<br>w/ Tabs<br>mm [in] | Depth<br>mm [in] |
| P1-M401-12DRS          | Input: Sinking/Sourcing;<br>Output: Relay    | 58.3<br>[2.3]    | 77.0<br>[3.03]                 | 86.4<br>[3.4]                | 88.9<br>[3.5]    |
| P1-M401-15DD2          | Input: Sinking/Sourcing;<br>Output: Sourcing |                  |                                |                              |                  |
| P1-M401-16DR           | Input: Sinking/Sourcing<br>Output: Relay     |                  |                                |                              |                  |
| P1-M412-4ADL2DAL-1     | Analog Input/Analog Output<br>(Current)      | 58.3<br>[2.3]    | 77.0<br>[3.03]                 | 86.4<br>[3.4]                | 97.0<br>[3.82]   |
| P1-M412-08ADL-1        | Analog Input (Current)                       |                  |                                |                              |                  |
| P1-M412-12DRS          | Input: Sinking/Sourcing;<br>Output: Relay    |                  |                                |                              |                  |
| P1-M412-15DD2          | Input: Sinking/Sourcing;<br>Output: Sourcing |                  |                                |                              |                  |
| P1-M412-16DR           | Relay Output                                 |                  |                                |                              |                  |
| P1-M412-16ND3          | Sinking/Sourcing<br>12–24 VDC Input          |                  |                                |                              |                  |
| P1-M622-04THM          | Thermocouple Input                           |                  |                                |                              |                  |
| P1-M622-4ADL2DAL-1     | Analog Input/Analog Output<br>(Current)      | 58.3<br>[2.3]    | 77.0<br>[3.03]                 | 87.1<br>[3.4]                | 97.0<br>[3.82]   |
| P1-M622-08ADL-1        | Analog Input (Current)                       |                  |                                |                              |                  |
| P1-M622-12DRS          | Input: Sinking/Sourcing;<br>Output: Relay    |                  |                                |                              |                  |
| P1-M622-15DD2          | Input: Sinking/Sourcing;<br>Output: Sourcing |                  |                                |                              |                  |
| P1-M622-16DR           | Relay Output                                 |                  |                                |                              |                  |
| P1-M622-16ND3          | Sinking/Sourcing<br>12–24 VDC Input          |                  |                                |                              |                  |



## Basic Dimensions (cont'd)

P1-RX Module

Units: mm [in]

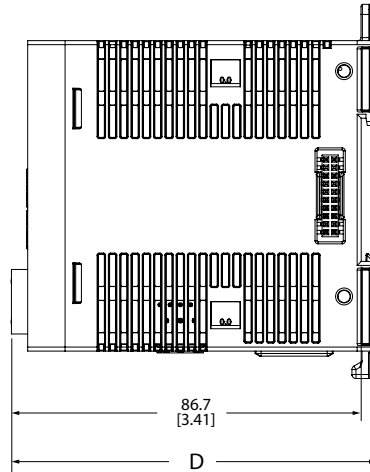
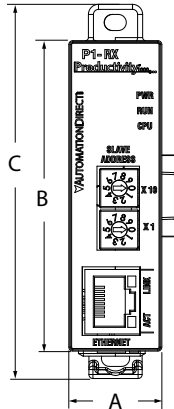

I/O Modules

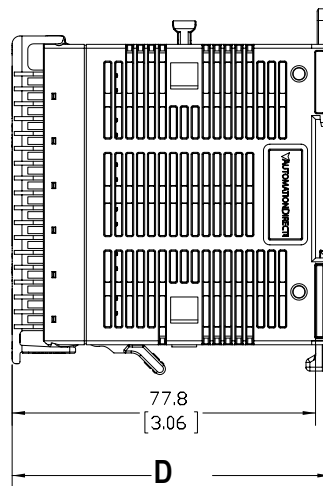
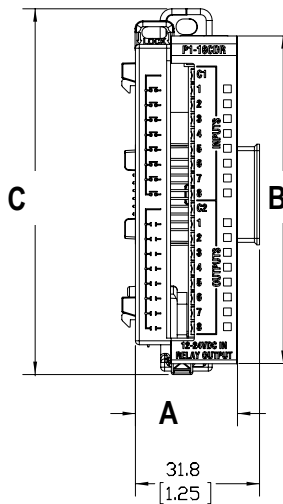

## Basic Dimensions (cont'd)

Units: mm [in]

P1-Mxxx PLC Modules

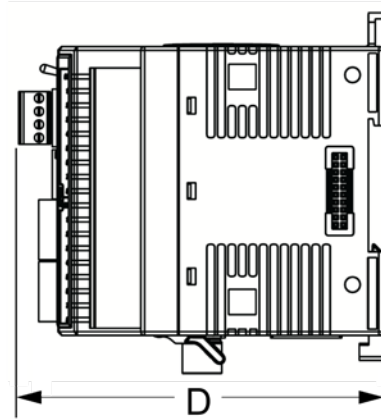
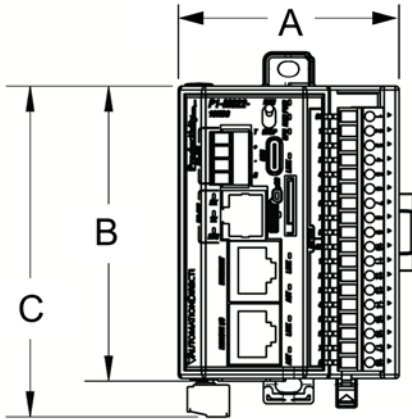

P1-M412, P1-M622

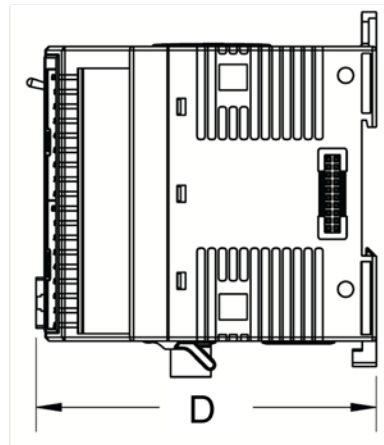

P1-M401

## Mounting Guidelines

### Enclosures

Your selection of a proper enclosure is important to ensure safe and proper operation of your Productivity®1000 system. Applications for the Productivity1000 system vary and may require additional hardware considerations. The minimum considerations for enclosures include:

- Conformance to electrical standards
- Protection from the elements in an industrial environment
- Common ground reference
- Maintenance of specified ambient temperature
- Access to the equipment
- Security or restricted access
- Sufficient space for proper installation and maintenance of the equipment



**NOTE:** Add 2" to mounting depth when using ZIPLink cable.

### Mounting Position

Mount the CPU and expansion modules horizontally, as shown in the illustration on the following page, to provide proper ventilation. Do not mount vertically, upside down, or on a flat horizontal surface.

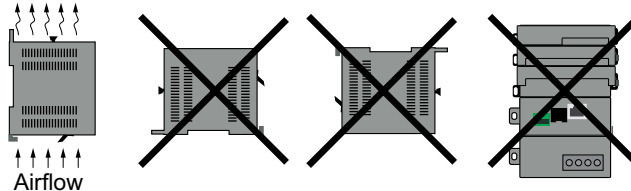

### Using Mounting Rails

The Productivity1000 modules can be secured within an enclosure or cabinet using mounting rails. Use rails that conform to DIN EN standard 50022. We offer a complete line of DIN rail, DINnectors and DIN rail mounted apparatus. The rails are approximately 35mm high with a depth of 7.5 mm. If you mount the module(s) on a DIN rail, consider using end brackets on each side of the base. The end brackets keep the module(s) from sliding horizontally along the rail, thus minimizing the possibility of accidentally pulling the wiring loose.

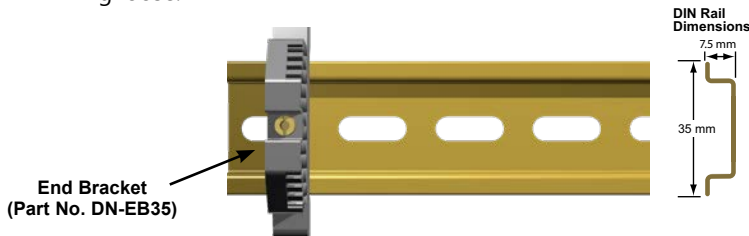

DIN Rail (Part No. DN-R35S1)

### Mounting Clearances

Provide a minimum clearance of 2 inches (50mm) on all sides of the module(s). Allow extra clearance for door mounted operator panels, push buttons, lights and other items. There should be a minimum of 3 inches (76mm) vertical clearance between the module(s) and any wire duct, and a minimum of 7.2 inches (183mm) vertical distance from chassis to chassis in a multiple unit installation.

### Temperature Considerations

The Productivity®1000 system enclosure should be installed in an environment which is within the specified equipment operating temperature. If the environment temperature deviates above or below the specification, measures such as cooling or heating the enclosure should be taken to maintain the specification.

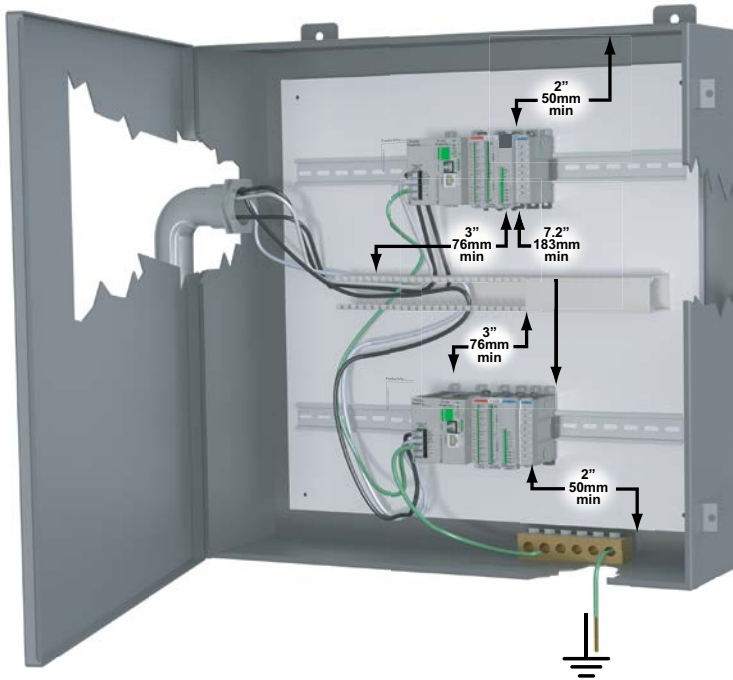

### Power Considerations

The Productivity1000 system is designed to be powered by 110/240 VAC or 125VDC power supply. The Productivity1000 has achieved CE certification without requiring EMF/RFI line noise filters on the AC power supply. Please review the European Union (CE) material in Appendix A for more information.

In addition to the panel layout guidelines, other specifications can affect the installation of a CPU system. Always consider the following:

- Environmental Specifications
- Power Requirements
- Agency Approvals
- Enclosure Selection and Component Dimensions

### Grounding

A sound common ground reference (earth ground) is essential for proper operation of the Productivity®1000 system. One side of all control circuits and power circuits along with the ground lead must be properly connected to earth ground (earthing) either by installing a ground rod in close proximity to the enclosure or by connecting to the incoming power system ground. There must be a single-point ground (i.e. copper bus bar) for all devices in the enclosure that require an earth ground.

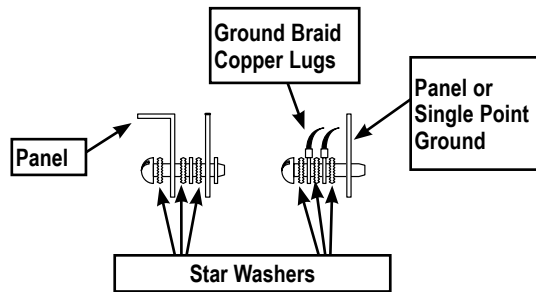

**WARNING:** Do not disconnect equipment unless power has been switched off or the area is known to be a non-hazardous environment.

### Agency Approvals

Some applications require agency approvals for particular components. The Productivity1000 CPU agency approvals are listed below:

- UL (Underwriters' Laboratories, Inc.)
- CUL (Canadian Underwriters' Laboratories, Inc.)
- CE (European Economic Union)



**NOTE:** See the "EU Directives(CE)" in Appendix A in this manual for more information.

### Installing the Power Supply



**NOTE:** Removable DC power connector must be removed prior to performing this step.

#### Step One:

With latch in “locked” position, align connectors on the side of each module and stack by pressing together. An audible click indicates lock is engaged.

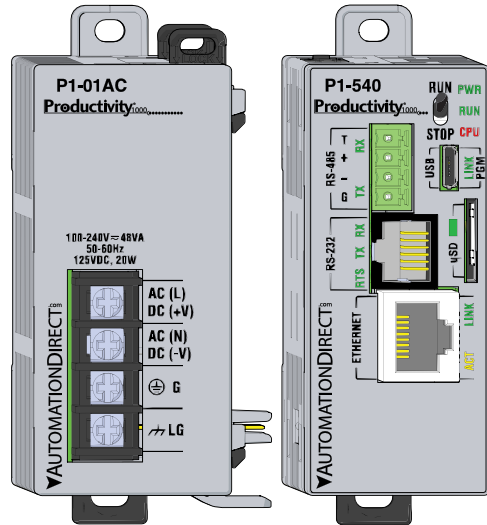
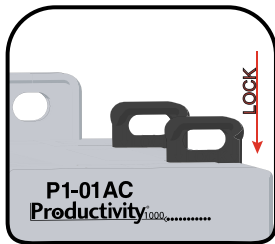

#### Step Two:

To unstack modules, pull locking latch up into the unlocked position and then pull modules apart.

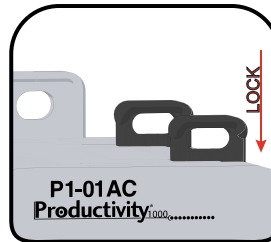
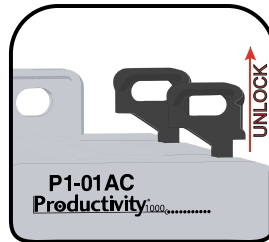

**WARNING:** Explosion hazard – Do not connect, disconnect or operate switches while circuit is live unless the area is known to be non-hazardous. Do not hot swap.

### DIN Rail Mounting P1000 System

If you examine the module(s), you'll notice retaining clips. To secure the module(s) to a DIN rail, place the module(s) onto the rail and gently push up on the retaining clips. The spring loaded clips lock the module onto the rail. To remove the module(s), pull down on the retaining clips, slightly lift up the base, and pull it away from the rail.

This installation procedure applies to the P1-540 or P1-550 CPU module with power supply.

**Step 1:** Rotate unit upwards as you engage rear DIN rail slot (image at right). Once engaged, rotate unit downwards, firmly pressing into DIN rail. A noticeable click affirms the unit is secure to DIN rail.

**Step 2:** Ensure all retaining clips are pushed up into DIN rail.



Push up  
retaining clips

Install end brackets on either side of unit to ensure unit will not slide along the DIN rail.

### Surface Mounting P1000 System

The P1000 system may be surface mounted as well. Extend the lower tabs for ease of access. Use mounting holes in top and bottom tabs to secure the unit to panel surface.



Extend lower tabs to  
install hardware for  
surface mount  
installation.

## Installing the I/O Modules

### Step One:

With latch in “locked” position, align connectors on the side of each module and stack by pressing together. An audible click indicates lock is engaged.

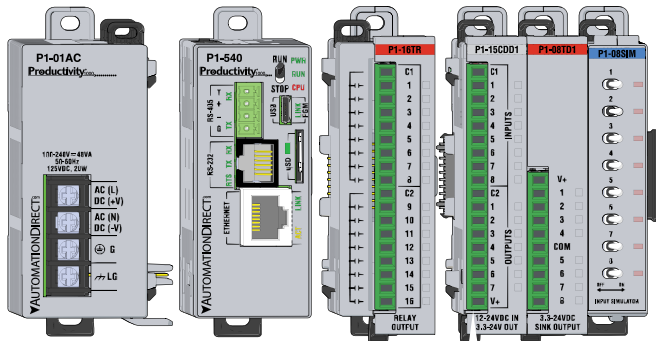
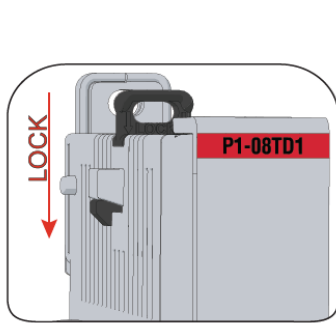

### Step Two:

To unstack modules, pull locking latch up into the unlocked position and then pull modules apart.



**WARNING:** Explosion hazard – Do not connect, disconnect modules or operate switches while circuit is live. Productivity®1000 System does not support Hot Swapping!



## Wiring Guidelines

### Power Supply Wiring

Connect the AC power source input wiring to the power supply as shown. The power supply terminals can accept up to 14AWG solid or stranded wire. Do not over tighten the terminal screws; the recommended torque is 7 to 9 inch-pounds (0.882 to 1.02 N·m).

#### P1-01AC and P1-02AC

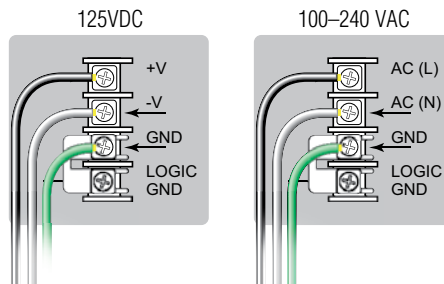

#### P1-01DC

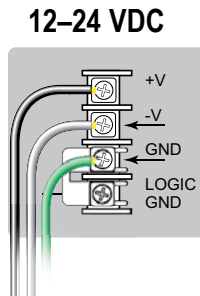

**WARNING:** Once the power wiring is connected, secure the terminal block cover in the closed position. When the cover is open there is a risk of electrical shock if you accidentally touch the connection terminals or power wiring.

### Grounding

A good common ground reference (earth ground) is essential for proper operation of the Productivity®1000 system. One side of all control circuits and power circuits along with the ground lead must be properly connected to earth ground by either installing a ground rod in close proximity to the enclosure or by connecting to the incoming power system ground. There must be a single-point ground (i.e. copper bus bar) for all devices in the enclosure that require an earth ground.

### Fuse Protection

Some of the Input and Output I/O module circuits do not have internal fuses. In order to protect your modules, we suggest you add external fuses to your I/O wiring. A fast-blow fuse with a lower current rating than the I/O bank's common current rating can be wired to each common; or a fuse with a rating of slightly less than the maximum current per output point can be added to each output. Refer to the I/O module specifications in Chapter 2 to find the maximum current per output point or per output common. Adding the external fuse does not guarantee the prevention of CPU damage, but it will provide added protection.

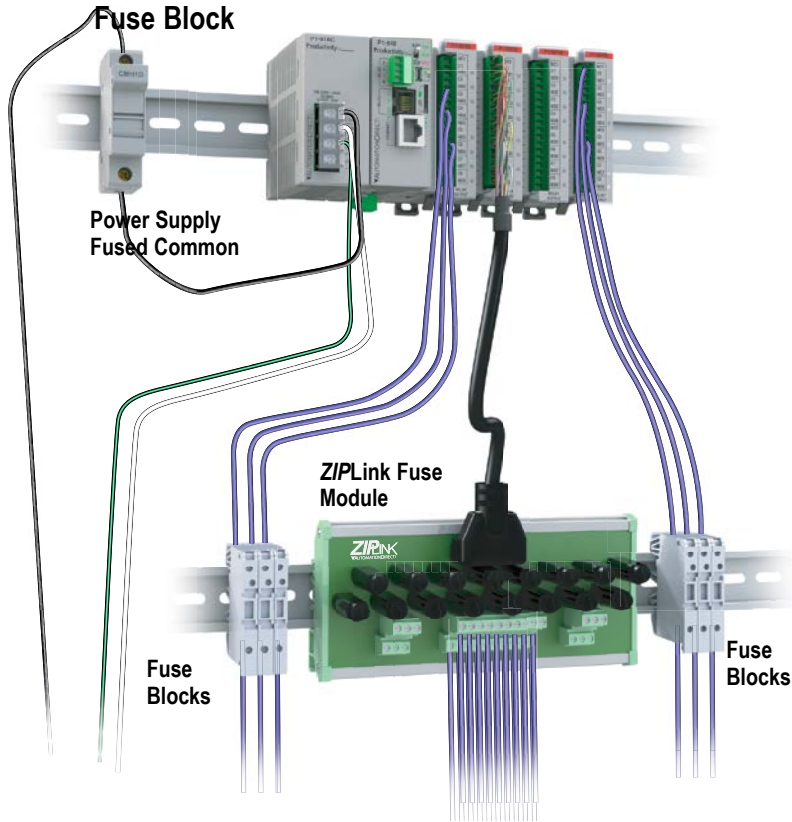

## I/O Module Wiring Options

There are two available methods for wiring most I/O modules: hand wiring to the optional removable I/O module terminal blocks or using the ZIPLink wiring system.



**NOTE:** Thermocouple and Thermistor modules are not compatible with the ZIPLink system and are shipped with fixed terminal blocks included.

### Hand Wiring System

Field wiring may be attached using the removable terminal block connector. Use Wire Strip Length reference on the terminal block as a guide when preparing wire for termination. For easier assembly, wire may be connected to terminal block prior to installing block into expansion module.

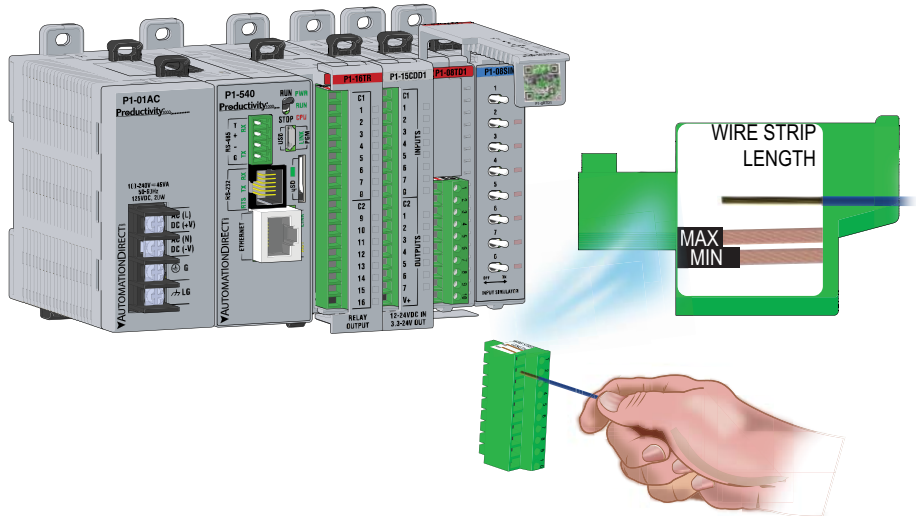

## I/O Module Wiring Options (cont'd)

### ZIPLink Wiring System

The ZIPLink wiring system is the recommended method, which allows quick and easy connection using cables that are prewired to the I/O module terminals at one end and plug into a ZIPLink connector module terminal block at the other end. Use the tables on the following pages to specify your ZIPLink wiring system.

ZIPLink Wiring System



ZIPLink Pre-Wired Cables



ZIPLink Module

### Terminal Block With Pigtail Cable

For most I/O modules you can also purchase ZIPLink pigtail cables.



ZIPLink Pigtail Cable

Input and Output Modules ZIPLink Selections

| Productivity1000 Input Module ZIPLink Selector |            |             |                           |                |
|--|------------|-------------|---------------------------|----------------|
| I/O Module                                     |            | ZIPLink     |                           |                |
| Input Module                                   | # of Terms | Component   | Module Part No.           | Cable Part No. |
| P1-08ND-TTL                                    | 10         | Feedthrough | ZL-RTB20 or<br>ZL-RTB20-1 | ZL-P1-CBL10*   |
| P1-08ND3                                       | 10         |             |                           | ZL-P1-CBL18*   |
| P1-16ND3                                       | 18         |             |                           | ZL-P1-CBL10*   |
| P1-08NE3                                       | 10         |             |                           | ZL-P1-CBL18*   |
| P1-16NE3                                       | 18         |             |                           | ZL-P1-CBL18*   |
| P1-08NA  | 10         |             |                           | ZL-P1-CBL10*   |

| Productivity1000 Output Module ZIPLink Selector |            |             |                           |                |
|---|------------|-------------|---------------------------|----------------|
| I/O Module                                      |            | ZIPLink     |                           |                |
| Output Module                                   | # of Terms | Component   | Module Part No.           | Cable Part No. |
| P1-08TD-TTL                                     | 10         | Feedthrough | ZL-RTB20 or<br>ZL-RTB20-1 | ZL-P1-CBL10*   |
| P1-08TD1  | 10         |             |                           | ZL-P1-CBL18*   |
| P1-08TD2  |            |             |                           | ZL-P1-CBL18*   |
| P1-15TD1  | 18         |             |                           | ZL-P1-CBL10*   |
| P1-15TD2  | 18         |             |                           | ZL-P1-CBL18*   |
| P1-08TA   | 10         |             |                           | ZL-P1-CBL10*   |
| P1-08TRS  | 10         |             |                           | ZL-P1-CBL18*   |
| P1-16TR   | 18         |             |                           | ZL-P1-CBL18*   |

| Productivity1000 Combo Modules ZIPLink Selector |            |             |                           |                |
|---|------------|-------------|---------------------------|----------------|
| I/O Module                                      |            | ZIPLink     |                           |                |
| Output Module                                   | # of Terms | Component   | Module Part No.           | Cable Part No. |
| P1-15CDD1                                       | 18         | Feedthrough | ZL-RTB20 or<br>ZL-RTB20-1 | ZL-P1-CBL18*   |
| P1-15CDD2                                       |            |             |                           | ZL-P1-CBL18*   |
| P1-16CDR  |            |             |                           | ZL-P1-CBL18*   |

\* Select the cable length by replacing the \* with: Blank = 0.5 m, -1 = 1.0 m, or -2 = 2.0 m.

## Analog Modules ZIPLink Selections

| Productivity1000 Analog Module ZIPLink Selector |                   |             |                              |                              |              |
|---|-------------------|-------------|------------------------------|------------------------------|--------------|
| Module  |                   | ZIPLink     |                              |                              |              |
| Analog Module                                   | # of Terms        | Component   | Module                       | Cable                        |              |
| P1-04AD   | 18                | Feedthrough | ZL-RTB20<br>or<br>ZL-RTB20-1 | ZL-P1-CBL18*                 |              |
| P1-04AD-1                                       | 10                | Feedthrough |                              | ZL-RTB20<br>or<br>ZL-RTB20-1 | ZL-P1-CBL10* |
| P1-04AD-2                                       |                   |             |                              |                              |              |
| P1-04ADL-1                                      |                   |             |                              |                              |              |
| P1-04ADL-2                                      |                   |             |                              |                              |              |
| P1-08ADL-1                                      |                   |             |                              |                              |              |
| P1-08ADL-2                                      |                   |             |                              |                              |              |
| P1-04RTD  | Matched Only      | See Note 1  |                              |                              |              |
| P1-04THM  | T/C Wire Only     | See Note 1  |                              |                              |              |
| P1-04NTC  | Copper Conductors | See Note 1  |                              |                              |              |
| P1-04DAL-1                                      | 10                | Feedthrough | ZL-RTB20<br>or<br>ZL-RTB20-1 | ZL-P1-CBL10*                 |              |
| P1-04DAL-2                                      |                   |             |                              |                              |              |
| P1-08DAL-1                                      |                   |             |                              |                              |              |
| P1-08DAL-2                                      |                   |             |                              |                              |              |

| Productivity1000 Analog Combo Module ZIPLink Selector |            |             |                           |              |
|---|------------|-------------|---------------------------|--------------|
| Module  |            | ZIPLink     |                           |              |
| Analog Module   | # of Terms | Component   | Module                    | Cable        |
| P1-4DAL2ADL-1   | 10         | Feedthrough | ZL-RTB20 or<br>ZL-RTB20-1 | ZL-P1-CBL10* |
| P1-4DAL2ADL-2   |            |             |                           |              |

| Productivity1000 Specialty Modules ZIPLink Selector |            |             |                           |              |
|---|------------|-------------|---------------------------|--------------|
| Module  |            | ZIPLink     |                           |              |
| Input Module  | # of Terms | Component   | Module                    | Cable        |
| P1-08SIM  | See Note 1 |             |                           |              |
| P1-02HSC  | See Note 1 |             |                           |              |
| P1-04PWM  | 10         | Feedthrough | ZL-RTB20 or<br>ZL-RTB20-1 | ZL-P1-CBL10* |

\* Select the cable length by replacing the \* with: Blank = 0.5 m, -1 = 1.0 m, or -2 = 2.0 m.  
 1. These modules are not supported by the ZIPLink wiring system.

P1 Mini Series PLC Modules ZIPLink Selections

| P1 Mini PLC Modules |            |             |                           |                |
|---------------------|------------|-------------|---------------------------|----------------|
| Module              |            | ZIPLink     |                           |                |
| Input Module        | # of Terms | Component   | Module Part No.           | Cable Part No. |
| P1-M401-12DRS       | 18         | Feedthrough | ZL-RTB20 or<br>ZL-RTB20-1 | ZL-P1-CBL18*   |
| P1-M401-15DD2       |            |             |                           |                |
| P1-M401-16DR        |            |             |                           |                |

| Productivity1000 Output Module ZIPLink Selector |                        |             |                           |                |
|---|------------------------|-------------|---------------------------|----------------|
| I/O Module                                      |                        | ZIPLink     |                           |                |
| Output Module                                   | # of Terms             | Component   | Module Part No.           | Cable Part No. |
| P1-M412-12DRS                                   | 18                     | Feedthrough | ZL-RTB20 or<br>ZL-RTB20-1 | ZL-P1-CBL18*   |
| P1-M412-15DD2                                   |                        |             |                           |                |
| P1-M412-16DR                                    |                        |             |                           |                |
| P1-M412-16ND3                                   |                        |             |                           |                |
| P1-M412-04THM                                   | Not ZIPLink compatible |             |                           |                |
| P1-M412-08ADL-1                                 | 10                     | Feedthrough | ZL-RTB20 or<br>ZL-RTB20-1 | ZL-P1-CBL10*   |
| P1-M412-4ADL2DAL-1                              |                        |             |                           |                |

| Productivity1000 Output Module ZIPLink Selector |                        |             |                           |                |
|---|------------------------|-------------|---------------------------|----------------|
| I/O Module                                      |                        | ZIPLink     |                           |                |
| Output Module                                   | # of Terms             | Component   | Module Part No.           | Cable Part No. |
| P1-M622-12DRS                                   | 18                     | Feedthrough | ZL-RTB20 or<br>ZL-RTB20-1 | ZL-P1-CBL18*   |
| P1-M622-15DD2                                   |                        |             |                           |                |
| P1-M622-16DR                                    |                        |             |                           |                |
| P1-M622-16ND3                                   |                        |             |                           |                |
| P1-M622-04THM                                   | Not ZIPLink compatible |             |                           |                |
| P1-M622-08ADL-1                                 | 10                     | Feedthrough | ZL-RTB20 or<br>ZL-RTB20-1 | ZL-P1-CBL10*   |
| P1-M622-4ADL2DAL-1                              |                        |             |                           |                |

\* Select the cable length by replacing the \* with: Blank = 0.5 m, -1 = 1.0 m, or -2 = 2.0 m.

### Removable Terminal Blocks (Optional)

The hand wiring method consists of purchasing the associated removable I/O module terminal block (table below) and hand wiring from the I/O terminal block to a DIN rail mounted terminal block.

#### P1-10RTB and P1-10RTB-1

| Removable Terminal Block Specifications |   |   |
|---|---|---|
| Part Number                             | P1-10RTB  | P1-10RTB-1  |
| Number of Positions                     | 10 Screw Terminals  | 10 Spring Clamp Terminals   |
| Wire Range                              | 30–16 AWG (0.051–1.31 mm <sup>2</sup> )<br>Solid / Stranded Conductor<br>3/64 in. (1.2 mm) Insulation Max.<br>1/4 in. (6–7 mm) Strip Length | 28–16 AWG (0.081–1.31 mm <sup>2</sup> )<br>Solid / Stranded Conductor<br>3/64 in. (1.2 mm) Insulation Max.<br>19/64 in. (7–8 mm) Strip Length |
| Conductors                              | "USE COPPER CONDUCTORS, 75°C" or Equivalent.  |   |
| Screw Driver                            | 0.1 inch (2.5 mm) Maximum*  |   |
| Screw Size                              | M2  | N/A   |
| Screw Torque                            | 2.5 lb-in (0.28 N-m)  | N/A   |

\* Recommended screw driver: P/N TW-SD-MSL-1.

#### P2-RTB and P2-RTB-1

| Removable Terminal Block Specifications |   |   |
|---|---|---|
| Part Number                             | P2-RTB  | P2-RTB-1  |
| Number of Positions                     | 18 Screw Terminals  | 18 Spring Clamp Terminals   |
| Wire Range                              | 30–16 AWG (0.051–1.31 mm <sup>2</sup> )<br>Solid / Stranded Conductor<br>3/64 in. (1.2 mm) Insulation Max.<br>1/4 in. (6–7 mm) Strip Length | 28–16 AWG (0.081–1.31 mm <sup>2</sup> )<br>Solid / Stranded Conductor<br>3/64 in. (1.2 mm) Insulation Max.<br>19/64 in. (7–8 mm) Strip Length |
| Conductors                              | "USE COPPER CONDUCTORS, 75°C" or Equivalent.  |   |
| Screw Driver                            | 0.1 inch (2.5 mm) Maximum*  |   |
| Screw Size                              | M2  | N/A   |
| Screw Torque                            | 2.5 lb-in (0.28 N-m)  | N/A   |

\* Recommended screw driver: P/N TW-SD-MSL-1.

### Removable Terminal Blocks, continued

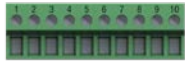

**P1-10RTB (screw terminals)  
Removable Terminal Block**

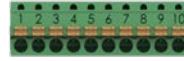

**P1-10RTB-1 (spring-clip terminals)  
Removable Terminal Block**

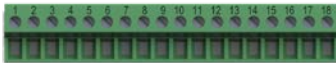

**P2-RTB (screw terminals)  
Removable Terminal Block**

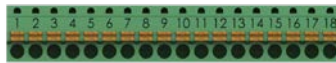

**P2-RTB-1 (spring-clip terminals)  
Removable Terminal Block**

### Terminal Block Installation

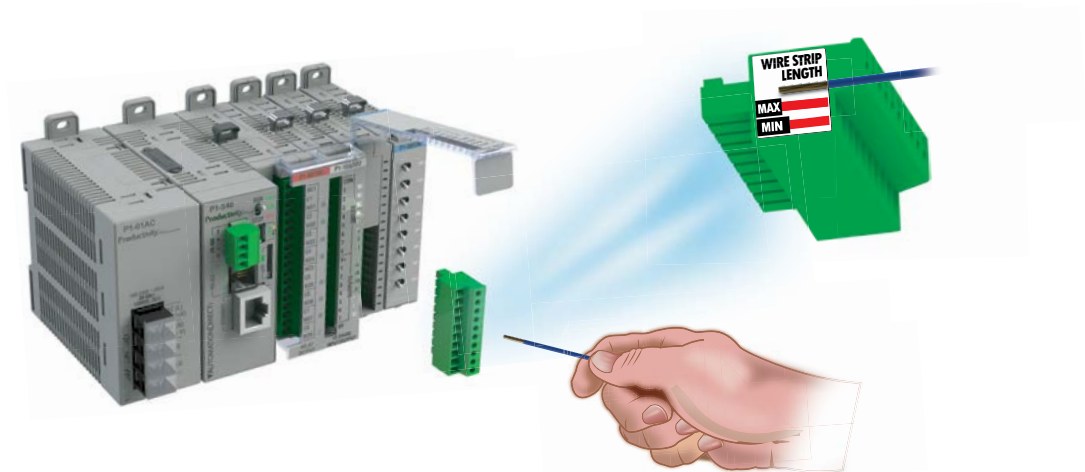

Reference the Wire Strip Length gauge printed on the end of the terminal strip as a guide to properly strip wire insulation prior to inserting into terminal block. For ease of assembly, block maybe wired prior to installation, if desired.

Insert terminal block as follows:

- Step 1: Raise finger-safe terminal guard.
- Step 2: Align terminal block with module terminal pins, ensuring correct orientation of block.
- Step 3: Firmly and evenly press terminal block onto terminal pins until seated. Lower finger-safe guard into place.

### Terminal Block Removal

---



**WARNING:** Ensure local and remote power supplies have been disconnected prior to removing terminal block.

---

Remove terminal block as follows:

- Step 1: Raise terminal cover.
- Step 2: Pull terminal block release lever forward.  
This will lift terminal block away from pins.
- Step 2: Grasp block firmly and pull away from module.

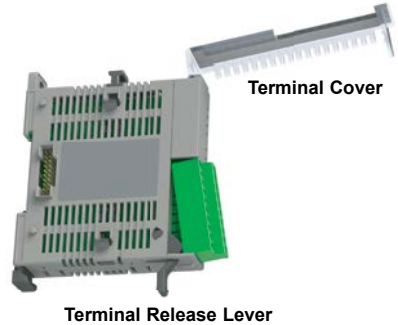

### Planning the I/O Wiring Routes

The following guidelines provide general information on how to wire the I/O connections to Productivity@1000 modules. For specific information on wiring a particular I/O module refer to the module specifications in Chapter 2.

1. If using removable terminal blocks, follow the wire size guidelines in the I/O modules specifications in Chapter 2.
2. Always use a continuous length of wire. Do not splice wires to create a needed length.
3. Use the shortest possible wire length.
4. Use wire trays for routing where possible.
5. Avoid running low voltage control wires near high voltage wiring.
6. Avoid confusion by laying input wiring separate from output wiring where possible.
7. To minimize voltage drops when wires must run a long distance, consider using multiple wires for the return line.
8. Avoid running DC wiring in close proximity to AC wiring where possible.
9. Avoid creating sharp bends in the wires; follow accepted Electrical Code standards.

## System Wiring Strategies

The Productivity®1000 system is very flexible and will work in many different wiring configurations. By studying this section before actual installation, you may find the best wiring strategy for your application. This will help to lower system cost and wiring errors, and avoid safety problems.

### CPU Isolation Boundaries

CPU circuitry is divided into three main regions separated by isolation boundaries, shown in the drawing below. Electrical isolation provides safety, so that a fault in one area does not damage another. The transformer in the power supply provides magnetic isolation between the primary and secondary sides. Optical isolators provide isolation in Input and Output circuits. This isolates logic circuitry from the field side, where factory machinery connects. The discrete inputs are isolated from the discrete outputs because each is isolated from the logic side. Isolation boundaries protect the devices which are connected to the communication ports, such as PCs and HMIs, from power input faults or field wiring faults. When wiring a CPU, it is extremely important to avoid making external connections that connect logic side circuits to any other.

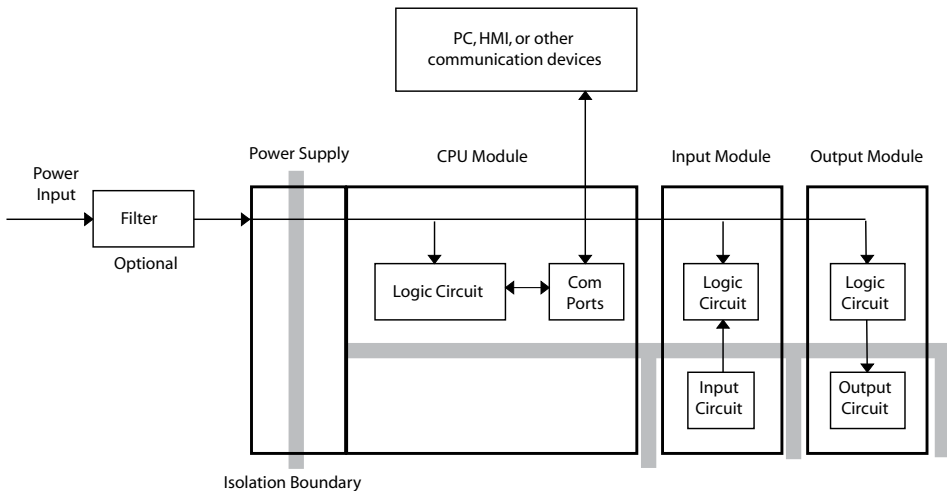

## Sinking/Sourcing Concepts

Before wiring field devices to the CPU I/O, it's necessary to have a basic understanding of "sinking" and "sourcing" concepts. Use of these terms occurs frequently in input or output circuit discussions. These terms only apply to DC circuits, not AC circuits. The purpose of this section is to explain the terms. The short definitions are as follows:

- Sinking = Path to supply ground (-) or switching ground.
- Sourcing = Path to supply source (+) or switching +V.

Input and output points that are either sinking or sourcing can conduct current in only one direction. This means it is possible to wire the external supply and field device to the I/O point with current trying to flow in the wrong direction, in which case the circuit will not operate.

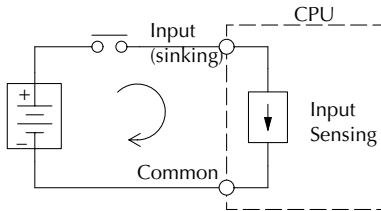

The diagram on the left shows a "sinking" CPU input. To properly connect the external supply, connect it so that the input provides a path to ground (-). Start at the CPU input terminal, follow through the input sensing circuit, exit at the common terminal, and connect the supply (-) to the common terminal.

The switch between the supply (+) and the input completes the circuit. Current flows in the direction of the arrow when the switch is closed. By applying the circuit principle above to the four possible combinations of input/output sinking/sourcing types, we have the four circuits as shown below.

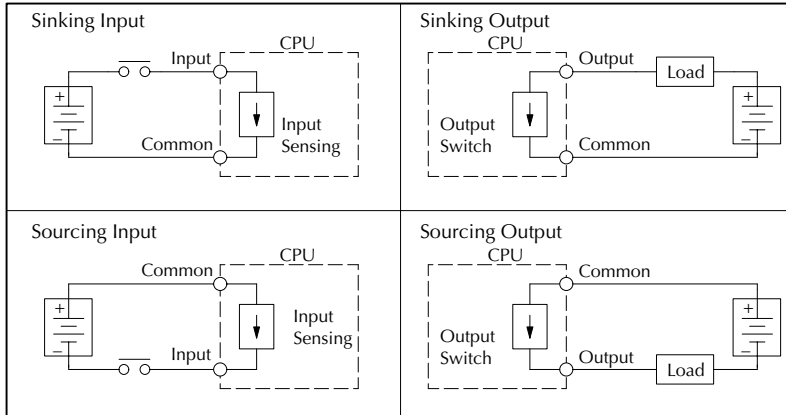

## I/O “Common Terminal” Concepts

In order for a CPU I/O circuit to operate, current must enter at one terminal and exit at another. This means at least two terminals are associated with every I/O point. In the figure below, the input or output terminal is the main path for the current. One additional terminal must provide the return path to the power supply.

If there was unlimited module space then every I/O point could have two dedicated terminals as the figure above shows. Providing this level of flexibility is not practical or necessary for most applications. Most I/O point groups share the return path (common) among two or more I/O points. The figure below shows a group (or bank) of four input points which share a common return path. In this way, the four inputs require only five terminals instead of eight.

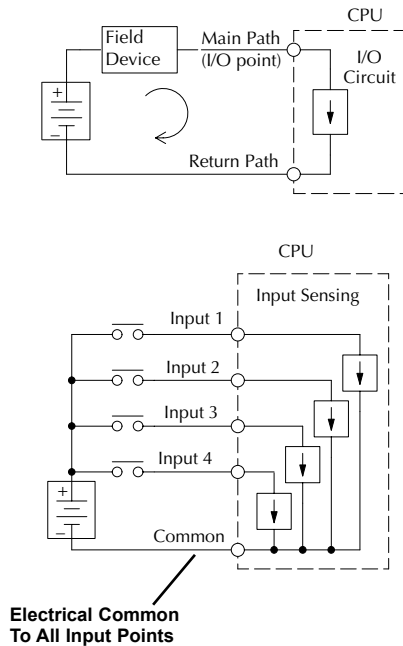

**NOTE:** In the circuit above, the current in the common path is equal to the sum of the energized channels. This is especially important in output circuits, where larger gauge wire is sometimes needed for the commons.

### DC Input Wiring Methods

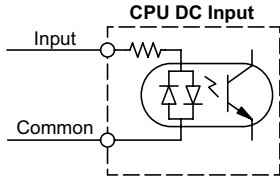

I/O modules with DC inputs can be wired as either sinking or sourcing inputs. The dual diodes (shown in this diagram) allow current to flow in either direction. Inputs grouped by a common point must be either all sinking or all sourcing. DC inputs typically operate in the range of +12–24 VDC.

#### Sinking Input Sensor (NPN Type) to CPU Sourcing Input

In the following example, a field device has an open-collector NPN transistor output. When energized, it sinks current to ground from the DC input point. The CPU input current is sourced from the common terminal connected to power supply (+).

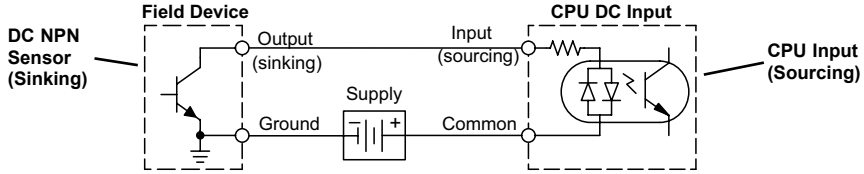

#### Sourcing Input Sensor (PNP Type) to CPU Sinking Input

In the following example, a field device has an open-emitter PNP transistor output. When energized, it sources current to the CPU input point, which sinks the current to ground. Since the field device loop is sourcing current, no additional power supply is required for the module.

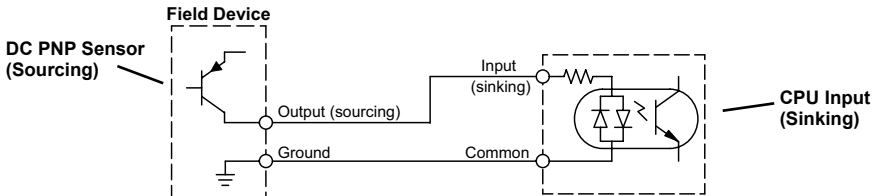

### DC Output Wiring Methods

I/O modules with DC output circuits are wired as all current sinking only or current sourcing only depending on which output module part number is used. DC outputs typically operate in the range of +5–24 VDC.

#### CPU Sinking Output to Sourcing Load Device

Many applications require connecting a CPU output point to a DC input on a field device load. This type of connection is made to carry a low-level DC signals.

In the following example, the CPU output point sinks current to ground (common) when energized. The output is connected to a field device load with a sourcing input.

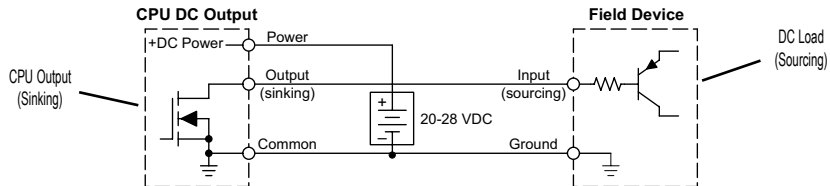

### CPU DC Sinking Output to Sinking Load Device

In the example below, a sinking output point is connected to the sinking input of a field device load. In this case, both the CPU output and field device input are sinking type. Since the circuit must have one sourcing and one sinking device, we add sourcing capability to the CPU output by using a pull-up resistor. In the circuit below, we connect R pull-up from the output to the DC output circuit power input.

**NOTE: DO NOT attempt to drive a heavy load (>25mA) with this pull-up method.**

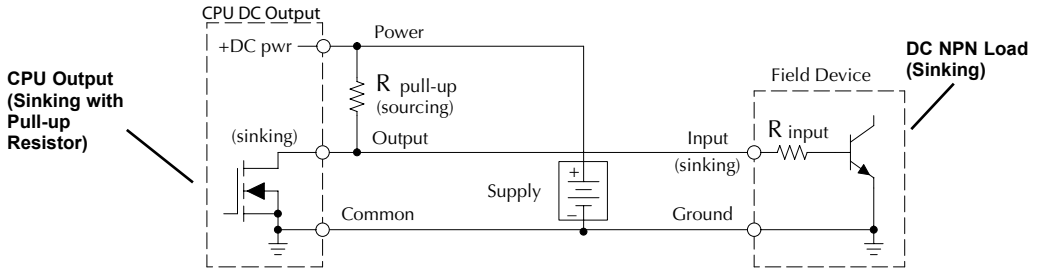

**NOTE:** Using the pull-up resistor to implement a sourcing output has the effect of inverting the output point logic. In other words, the field device input is energized when the CPU output is OFF, from a ladder logic point-of-view. Your ladder program must comprehend this and generate an inverted output. Or, you may choose to cancel the effect of the inversion elsewhere, such as in the field device.

It is important to choose the correct value of R<sub>pull-up</sub>. In order to do so, we need to know the nominal input current to the field device (I<sub>input</sub>) when the input is energized. If this value is not known, it can be calculated as shown (a typical value is 15mA). Then use I<sub>input</sub> and the voltage of the external supply to compute R<sub>pull-up</sub>. Then calculate the power P<sub>pull-up</sub> (in watts), in order to size R<sub>pull-up</sub> properly.

$$I_{\text{input}} = \frac{V_{\text{input (turn-on)}}}{R_{\text{input}}}$$

$$R_{\text{pull-up}} = \frac{V_{\text{supply}} - 0.7}{I_{\text{input}}} - R_{\text{input}}$$

$$P_{\text{pull-up}} = \frac{V_{\text{supply}}^2}{R_{\text{pull-up}}}$$

### Relay Outputs - Wiring Methods

Relay outputs are available for the Productivity®1000. Relays are best for the following applications:

- Loads that require higher currents than the solid-state outputs can deliver
- Cost-sensitive applications
- Some output channels need isolation from other outputs (such as when some loads require different voltages than other loads)

Some applications in which NOT to use relays:

- Loads that require currents under 10mA
- Loads which must be switched at high speed or heavy duty cycle.

#### Relay with Form A contacts

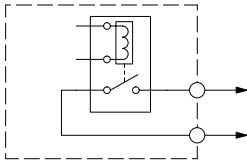

Relay outputs are available in two contact arrangements. Form A type, or SPST (single pole, single throw) type.

They are normally open and are the simplest to use. The Form C, or SPDT (single pole, double throw) type has a center contact which moves and a stationary contact on either side. This provides a normally closed contact and a normally open contact.

#### Relay with Form C contacts

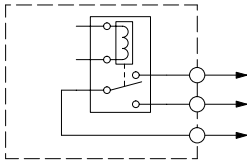

The relays in some relay output modules share common terminals, which connect to the wiper contact in each relay of the bank. Other relay modules have relays which are completely isolated from each other. In all cases, the module drives the relay coil when the corresponding output point is on.

## Relay Outputs – Transient Suppression for Inductive Loads

The following pages are intended to give a quick overview of the negative effects of transient voltages on a control system and provide some simple advice on how to effectively minimize them. The need for transient suppression is often not apparent to the newcomers in the automation world. Many mysterious errors that can afflict an installation can be traced back to a lack of transient suppression.

### What is a Transient Voltage and Why is it Bad?

Inductive loads (devices with a coil) generate transient voltages as they transition from being energized to being de-energized. If not suppressed, the transient can be many times greater than the voltage applied to the coil. These transient voltages can damage CPU outputs or other electronic devices connected to the circuit, and cause unreliable operation of other electronics in the general area. Transients must be managed with suppressors for long component life and reliable operation of the control system.

This example shows a simple circuit with a small 24V/125mA/3W relay. As you can see, when the switch is opened, thereby de-energizing the coil, the transient voltage generated across the switch contacts peaks at 140V.

### Example Circuit with no Suppression

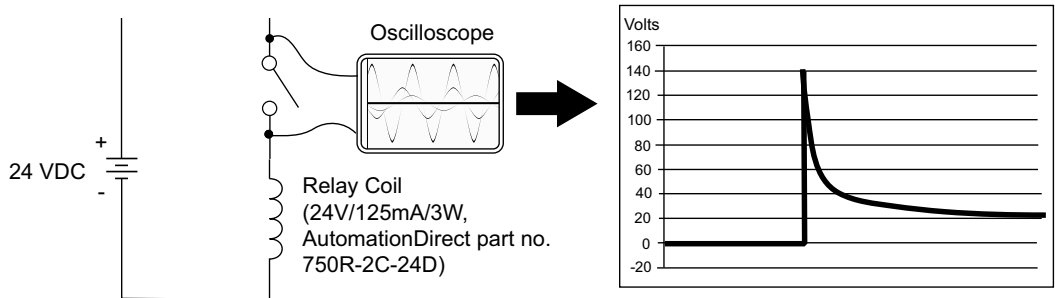

In the same circuit, replacing the relay with a larger 24V/290mA/7W relay will generate a transient voltage exceeding 800V (not shown). Transient voltages like this can cause many problems, including:

- Relay contacts driving the coil may experience arcing, which can pit the contacts and reduce the relay's lifespan.
- Solid state (transistor) outputs driving the coil can be damaged if the transient voltage exceeds the transistor's ratings. In extreme cases, complete failure of the output can occur the very first time a coil is de-energized.
- Input circuits, which might be connected to monitor the coil or the output driver, can also be damaged by the transient voltage.

A very destructive side-effect of the arcing across relay contacts is the electromagnetic interference (EMI) it can cause. This occurs because the arcing causes a current surge, which releases RF energy. The entire length of wire between the relay contacts, the coil, and the power source carries the current surge and becomes an antenna that radiates the RF energy. It will readily couple into parallel wiring and may disrupt the CPU and other electronics in the area. This EMI can make an otherwise stable control system behave unpredictably at times.

## CPU's Integrated Transient Suppressors

Although the CPU outputs typically have integrated suppressors to protect against transients, they are not capable of handling them all. It is usually necessary to have some additional transient suppression for an inductive load.

Here is another example using the same 24V/125mA/3W relay used earlier. This example measures the PNP transistor output of a typical CPU, which incorporates an integrated Zener diode for transient suppression. Instead of the 140V peak in the first example, the transient voltage here is limited to about 40V by the Zener diode. While the CPU will probably tolerate repeated transients in this range for some time, the 40V is still beyond the module's peak output voltage rating of 30V.

### Example: Small Inductive Load with Only Integrated Suppression

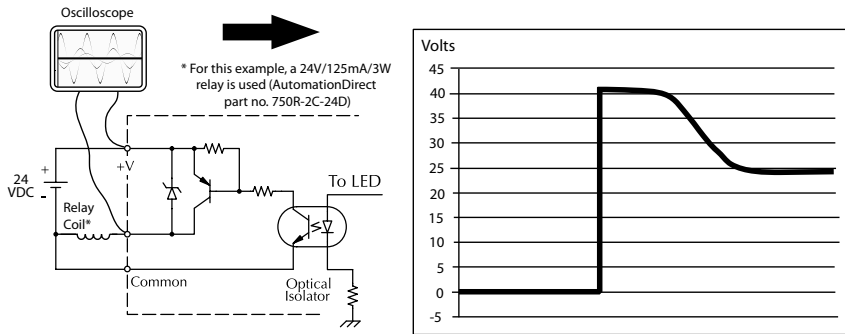

The next example uses the same circuit as above, but with a larger 24V/290mA/7W relay, thereby creating a larger inductive load. As you can see, the transient voltage generated is much worse, peaking at over 50V. Driving an inductive load of this size without additional transient suppression is very likely to permanently damage the CPU output.

### Example: Larger Inductive Load with Only Integrated Suppression

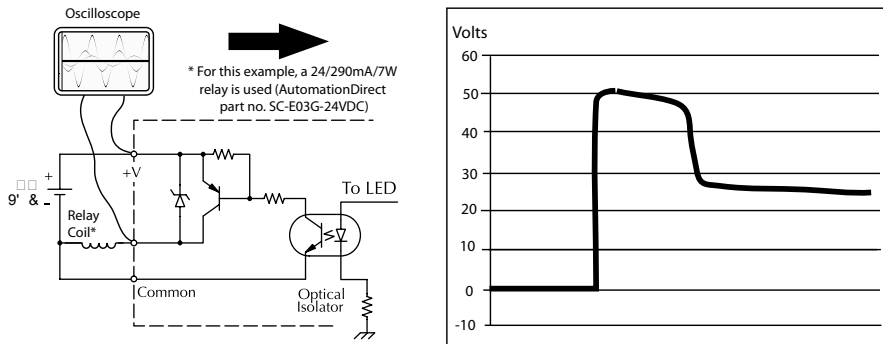

Additional transient suppression should be used in both of these examples. If you are unable to measure the transients generated by the connected loads of your control system, using additional transient suppression on all inductive loads would be the safest practice.

## Types of Additional Transient Protection

### DC Coils:

The most effective protection against transients from a DC coil is a flyback diode. A flyback diode can reduce the transient to roughly 1V over the supply voltage, as shown in this example.

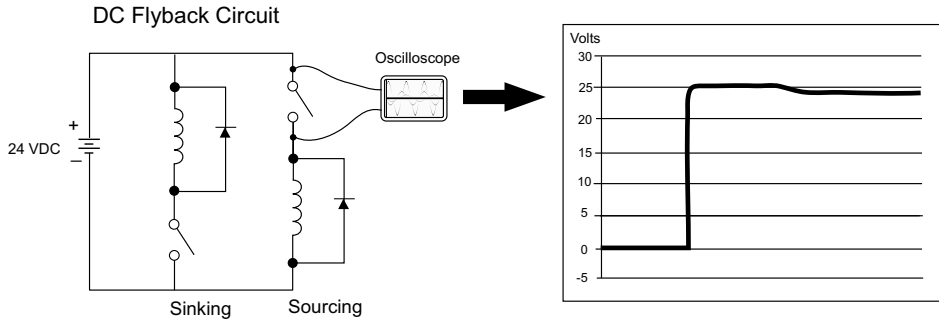

Many AutomationDirect socketed relays and motor starters have add-on flyback diodes that plug or screw into the base, such as the AD-ASMD-250 protection diode module and 784-4C-SKT-1 socket module shown below. If an add-on flyback diode is not available for your inductive load, an easy way to add one is to use AutomationDirect's DN-D10DR-A diode terminal block, a 600VDC power diode mounted in a slim DIN rail housing.



**AD-ASMD-250**  
Protection Diode Module



**784-4C-SKT-1**  
Relay Socket

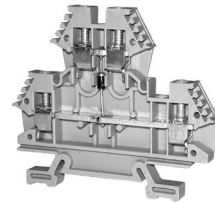

**DN-D10DR-A**  
Diode Terminal Block

## Chapter 5: Installation and Wiring

Two more common options for DC coils are Metal Oxide Varistors (MOV) or TVS diodes. These devices should be connected across the driver (CPU output) for best protection as shown below. The optimum voltage rating for the suppressor is the lowest rated voltage available that will NOT conduct at the supply voltage, while allowing a safe margin.

AutomationDirect's ZL-TSD8-24 transorb module is a good choice for 24VDC circuits. It has a bank of 8 uni-directional 30V TVS diodes. Since they are uni-directional, be sure to observe the polarity during installation. MOVs or bi-directional TVS diodes would install at the same location, but have no polarity concerns.



**ZL-TSD8-24**

**Transorb Module**

**DC MOV or TVS Diode Circuit**

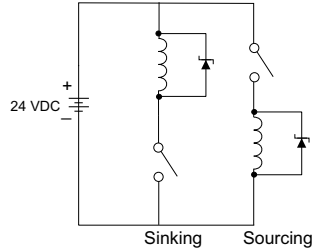

### AC Coils:

Two options for AC coils are MOVs or bi-directional TVS diodes. These devices are most effective at protecting the driver from a transient voltage when connected across the driver (CPU output) but are also commonly connected across the coil. The optimum voltage rating for the suppressor is the lowest rated voltage available that will NOT conduct at the supply voltage, while allowing a safe margin.

AutomationDirect's ZL-TSD8-120 transorb module is a good choice for 120VAC circuits. It is a bank of eight bi-directional 180V TVS diodes.



**ZL-TSD8-120**

**Transorb Module**

**AC MOV or Bi-Directional Diode Circuit**

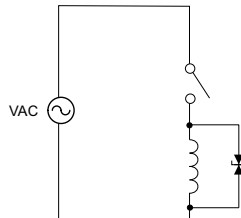

**NOTE:** Manufacturers of devices with coils frequently offer MOV or TVS diode suppressors as an add-on option which mount conveniently across the coil. Before using them, carefully check the suppressor ratings. Just because the suppressor is made specifically for that part does not mean it will reduce the transient voltages to an acceptable level.

For example, a MOV or TVS diode rated for use on 24-48 VDC coils would need to have a high enough voltage rating to NOT conduct at 48V. That suppressor might typically start conducting at roughly 60VDC. If it were mounted across a 24V coil, transients of roughly 84V (if sinking output) or -60V (if sourcing output) could reach the CPU output. Many semiconductor CPU outputs cannot tolerate such levels.

# COMMUNICATIONS

---



# CHAPTER 6

## In This Chapter

|   |             |
|---|-------------|
| <b>Communications</b> .....   | <b>6-1</b>  |
| Communication Ports .....   | 6-1         |
| P1 Mini PLC Communications .....                                      | 6-3         |
| microSD Card: .....   | 6-4         |
| MicroUSB: .....   | 6-4         |
| RS-232: .....   | 6-4         |
| <b>Communications: Connectivity</b> .....                             | <b>6-10</b> |
| CPU Port Connections, P1-540 CPU .....                                | 6-10        |
| <b>Communications: Connectivity</b> .....                             | <b>6-11</b> |
| CPU Port Connections, P1-550 and P1-622 CPUs.....                     | 6-11        |
| ASCII and Custom Protocol Functionality.....                          | 6-16        |
| ASCII Instructions .....  | 6-16        |
| Custom Protocol Instructions .....                                    | 6-17        |
| <b>Communications: Ethernet</b> .....                                 | <b>6-19</b> |
| TCP and UDP Port Numbers .....  | 6-19        |
| IP Addressing and Subnetting.....                                     | 6-19        |
| PC Setup.....   | 6-20        |
| CPU Setup .....   | 6-21        |
| TCP Connection Behavior with Modbus TCP and Network Instructions..... | 6-22        |
| <b>Communications Modbus Functionality</b> .....                      | <b>6-23</b> |
| Master/Client Function Code and Data Type Support.....                | 6-23        |
| Slave/Server Function Code and Data Type Support .....                | 6-25        |
| Assigning Modbus Addresses to Tags .....                              | 6-26        |
| Modbus Options.....   | 6-29        |
| Modbus Instructions .....   | 6-32        |
| Network Instructions.....   | 6-34        |

## Table of Contents

---

|   |             |
|---|-------------|
| Automatic Poll versus Manual Polling and Interlocking .....     | 6-35        |
| Message Queue .....   | 6-37        |
| <b>EtherNet/IP for the Productivity Series .....</b>            | <b>6-38</b> |
| Terminology Definitions.....                                    | 6-38        |
| Network Layer Chart .....                                       | 6-39        |
| EtherNet/IP Data.....   | 6-39        |
| Class 1 and Class 3 Connections.....                            | 6-40        |
| Setup Example 1: Productivity®1000 as EtherNet/IP Adapter ..... | 6-40        |
| Example 2: Productivity®1000 as EtherNet/IP Scanner.....        | 6-43        |
| Troubleshooting Tips:.....                                      | 6-46        |
| EtherNet/IP I/O Message Troubleshooting:.....                   | 6-48        |
| EtherNet/IP Explicit Message Troubleshooting: .....             | 6-48        |
| ProNET .....  | 6-49        |
| Custom Protocol over Ethernet Functionality .....               | 6-50        |
| Hardware Configuration .....                                    | 6-51        |
| Custom Protocol Ethernet Instruction.....                       | 6-52        |
| <b>Communications: Remote I/O and GS-Drives .....</b>           | <b>6-53</b> |
| Design Considerations for Remote I/O and GS-Drives .....        | 6-53        |
| <b>Communications: Port Configuration.....</b>                  | <b>6-59</b> |
| External Ethernet Port Settings .....                           | 6-60        |
| Local Ethernet Port Settings.....                               | 6-61        |
| Remote Access Configuration .....                               | 6-61        |
| Serial Configuration.....                                       | 6-62        |
| RS-232 and RS-485 Port Settings .....                           | 6-62        |
| <b>Communications: Error Codes.....</b>                         | <b>6-65</b> |
| <b>P1000 EtherNet/IP Error Codes .....</b>                      | <b>6-66</b> |

# Communications

## Communication Ports

The AutomationDirect Productivity®1000 CPUs are provided with several Communications Ports, each referenced below by a number. Follow the associated numbered sections following for a detailed description of each of these ports.

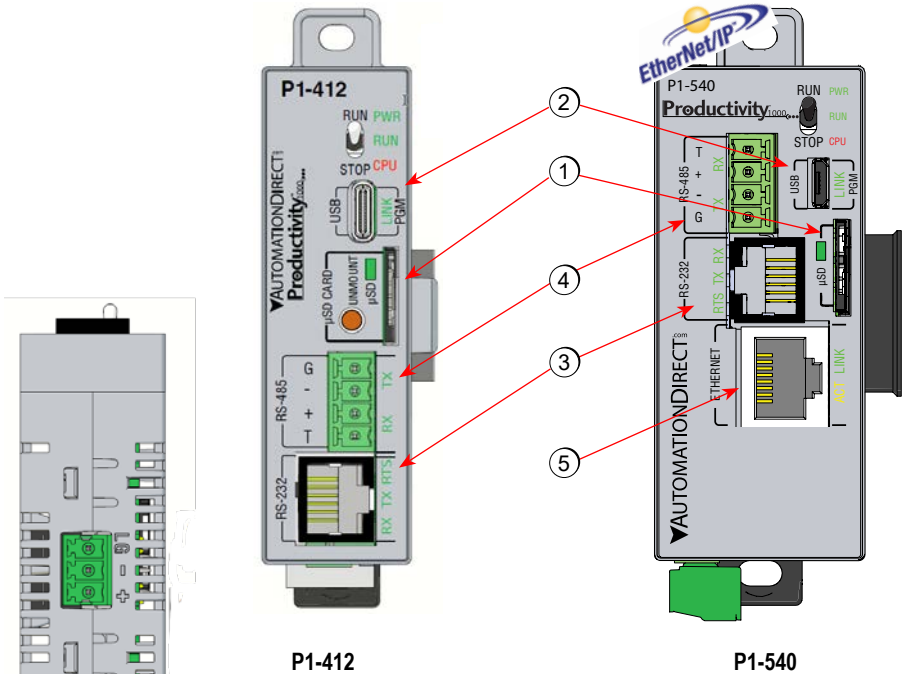

P1-412

P1-540

P1-412  
(Bottom View)

| General Specifications |                               |
|------------------------|-------------------------------|
| Item #                 | Communication Port            |
| 1                      | microSD Slot                  |
| 2                      | MicroUSB 2.0 Programming Port |
| 3                      | RS232 Serial Port (RJ12)      |
| 4                      | RS485 Serial Port (TB Style)  |
| 5                      | 10/100 MB Ethernet Port       |



**NOTE:** The microUSB port is NOT compatible with older 1.0/1.1 full speed USB devices.

# Communications, Cont'd

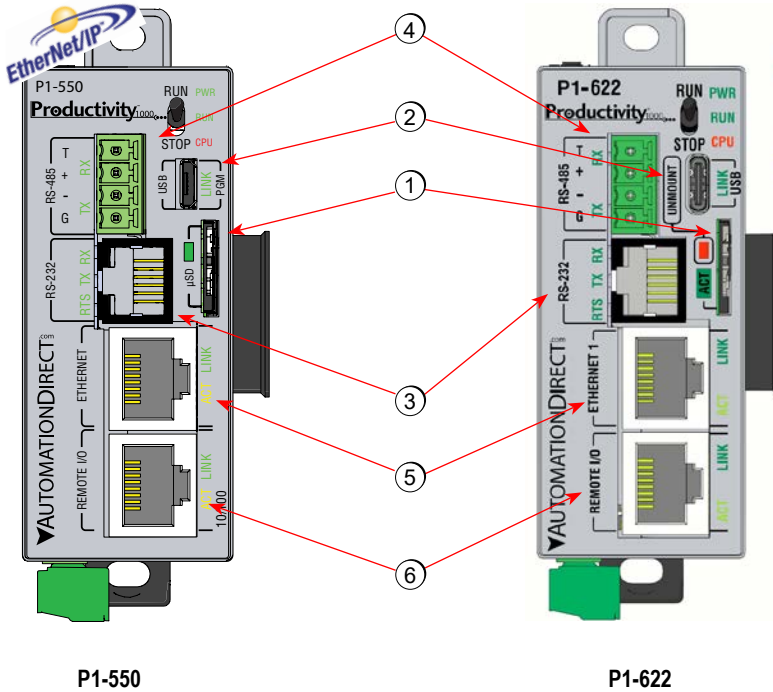

| General Specifications |                                     |
|------------------------|-------------------------------------|
| Item #                 | Communication Port                  |
| 1                      | microSD Slot                        |
| 2                      | MicroUSB 2.0 Programming Port       |
| 3                      | RS232 Serial Port (RJ12)            |
| 4                      | RS485 Serial Port (TB Style)        |
| 5                      | 10/100 MB Ethernet Port             |
| 6                      | 10/100 MB Ethernet Port, Remote I/O |



**NOTE:** The microUSB port is NOT compatible with older 1.0/1.1 full speed USB devices.

# Communications, Cont'd

## P1 Mini PLC Communications

The AutomationDirect Productivity®1000 Mini series PLCs are provided with Communications Ports similar to the P1000 CPU modules on the preceding pages. Follow the associated numbered sections for a detailed description of each of these ports.

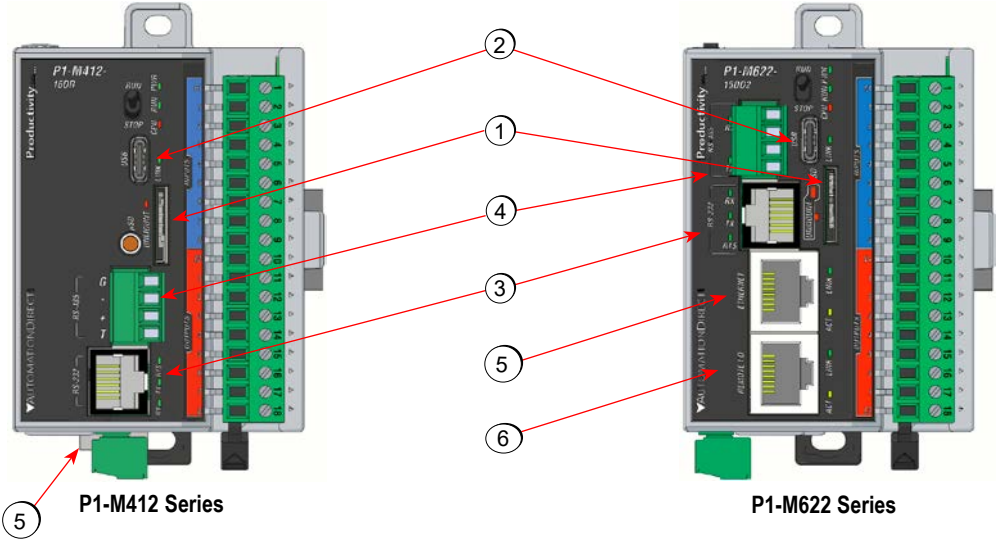

| General Specifications |                                     |
|------------------------|-------------------------------------|
| Item #                 | Communication Port                  |
| 1                      | microSD Slot                        |
| 2                      | MicroUSB 2.0 Programming Port       |
| 3                      | RS232 Serial Port (RJ12)            |
| 4                      | RS485 Serial Port (TB Style)        |
| 5                      | 10/100 MB Ethernet Port             |
| 6                      | 10/100 MB Ethernet Port, Remote I/O |

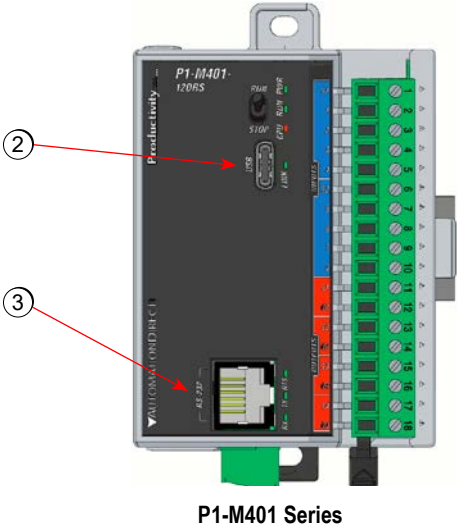

**NOTE:** The microUSB port is NOT compatible with older 1.0/1.1 full speed USB devices.

### Communication Ports, continued

#### 1 microSD Card:

The microSD card slot is provided for data logging capability. Files stored on the microSD card by a CPU or the Productivity Suite programming software are stored under a default name, so only one project may be handled at a time on a microSD card. Existing projects on the microSD card will be overwritten without a prompt.

Data Logging: The Data Logger tool allows setup of periodic or event-based data logging of tag and System Errors to the microSD card. Data Logger setup is accessed under the Monitor & Debug Menu. See Communications Connectivity section for more information.

#### 2 MicroUSB:

The microUSB 2.0 port uses a Type B connector. It is used for connection to a PC running the Productivity Suite programming software and Online monitoring of program.

#### 3 RS-232:

The RS-232 port is an RJ-12 connector located on the lower right front of the CPU. This port can be used for:

- Modbus RTU Master connections.
- Modbus RTU Slave connections.
- ASCII Incoming and Outgoing communications.
- Custom Protocol Incoming and Outgoing communications.

#### Modbus RTU Master connections:

The RS-232 port is intended to be used for point-to-point connections but it is possible to connect up to 128 devices on a network if an RS-232 to RS-485/422 converter is connected to the port (such as a FA-ISOCOM). This is accomplished by using the communications instructions in the ladder project (MRX, MWX, RX, WX). If 4-wire RS-485 or RS-422 communications is needed, using this port with an FA-ISOCOM is the best method. See Communications Connectivity section in this manual for more information.

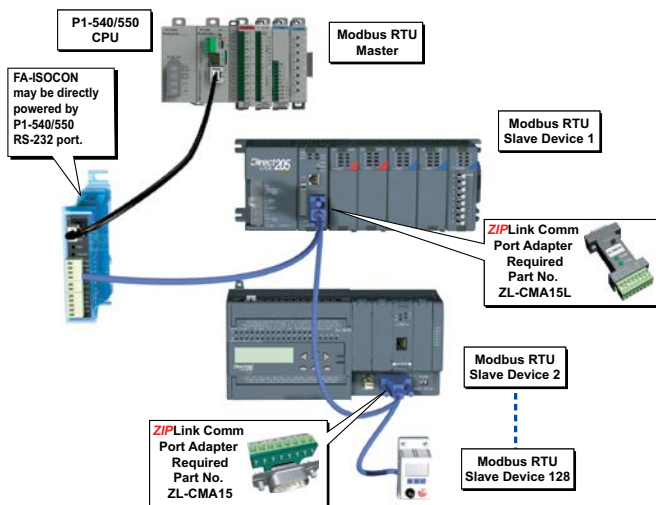

### Communication Ports, continued

#### Modbus RTU Slave connections:

The RS-232 port is intended to be used for point-to-point connections but it is possible for the RS-232 port to be used on a Modbus RTU network by using a RS-232 to RS-485/422 converter. The port is addressable in the Hardware Configuration in the Productivity Suite programming software. It is important to note that the RS-232 port cannot be a Modbus RTU master and slave concurrently. If the port is set to Modbus RTU and there are no communications instructions (MRX, MWX, RX, WX) in the project, the CPU will automatically respond to Modbus requests from a Modbus master. See Communications Connectivity section for more information.

#### ASCII Incoming and Outgoing communications:

The RS-232 port can be used for sending and receiving non-sequenced String data. This feature is typically used for receiving bar code strings from a scanner or sending statistical data to a terminal or serial printer using the ASCII IN and ASCII OUT instructions. See Communications Connectivity section for more information.

RS-232 ASCII In Communication

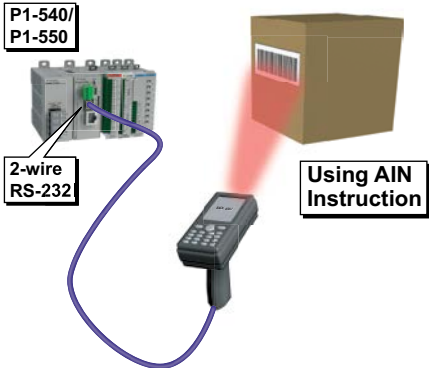

RS-232 ASCII Out Communication

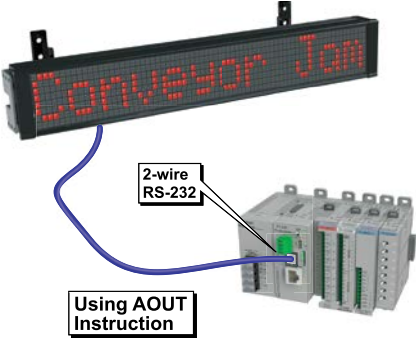

#### Custom Protocol Incoming and Outgoing communications:

The RS-232 port can be used for sending and receiving non-sequenced byte arrays to various devices. This function is typically used for communicating with devices that don't support the Modbus protocol but have another serial communications protocol. This is accomplished by using the Custom Protocol In and Custom Protocol Out instructions. The RS-232 port is intended to be used for point-to-point connections but it is possible for the RS-232 port to be used on a multi-node network by using a RS-232 to RS-485/422 converter. See Communications Connectivity section for more information.

RS-232 Custom Protocol In and Out

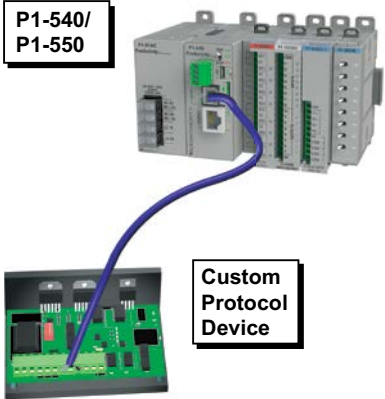

## Communication Ports, continued

### 4 The Modbus RTU Slave Connections:

The RS-485 network port is used for multi-node networks. The port is addressable in the Hardware Configuration in the Productivity Suite programming software. If the port is set to Modbus RTU and there are no communications instructions (MRX, MWX, RX, WX) in the project, the CPU will automatically respond to Modbus requests from a Modbus master. See Communications Connectivity section for more information.

**RS-485 Modbus RTU Slave Network Topology**

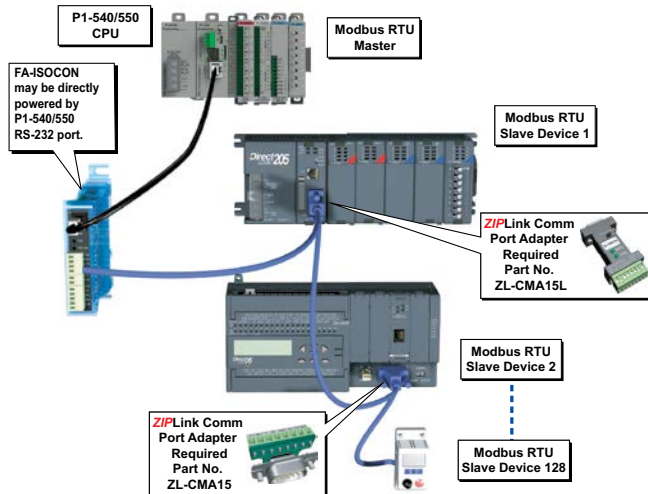

**NOTE:** See respective PLC Manual for communication port cable pinouts.

ASCII Incoming and Outgoing Communications: The RS-485 port can be used for sending and receiving non-sequenced String data. If long distances are required between the ASCII device and the CPU, the RS-485 port is the better selection because of its increased distance support (1,000 meters). ASCII communications are typically used for receiving bar code strings from a scanner or sending statistical data to a terminal or serial printer using the ASCII IN and ASCII OUT instructions. See Communications Connectivity section for more information.

**RS-232 ASCII In Communication**

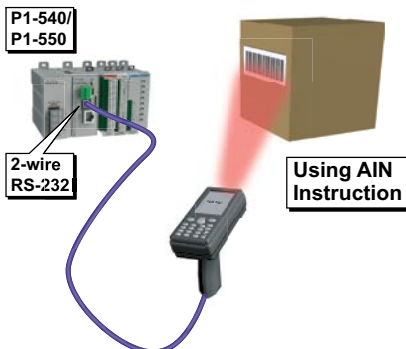

**RS-232 ASCII Out Communication**

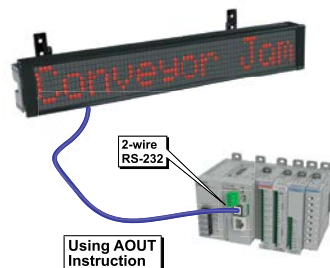

Communication Ports, continued

5 Ethernet:

The Ethernet port is 10/100Base-T Ethernet with an RJ-45 style connector. It is used for: Connection to a PC running the Productivity Suite programming software.

- Modbus TCP Client connections (Modbus requests sent from the CPU).
- Modbus TCP Server connections (Modbus requests received by the CPU).
- Custom Protocol over Ethernet
- ProNET
- EtherNet/IP Scanner (32 Adapters)
- EtherNet/IP Adapter (4 scanners) with 8 connections per device.
- Outgoing Email.

**Modbus TCP Client Connections:** The CPU can connect to 16 Modbus TCP server devices concurrently by means of communications instructions in the ladder program (MRX, MWX, RX, WX). It is possible to connect to more than 16 Modbus TCP server devices, but not concurrently.

This is accomplished by having communications instructions for more than 16 devices in the ladder program and controlling the enabling and disabling of the instructions so that only 16 devices are enabled at a given time. To connect to non Productivity®1000 devices, use the MRX (Modbus Read) and MWX (Modbus Write) instructions.

The greatest difference in the RX versus the MRX is that with the RX, the Tag Name in the target CPU can be referenced directly and does not need a corresponding Modbus address. This is accomplished by mapping local and remote tagnames together within the local CPU's RX instruction. Once the instruction is set up to read a remote project, the "Tags of Remote Project" or "Array Tags of Remote Project" drop down lists will be accessible. Map the Tag of the Remote project to a Tag in the Local project to read this data.

Modbus TCP Client (RX-WX)

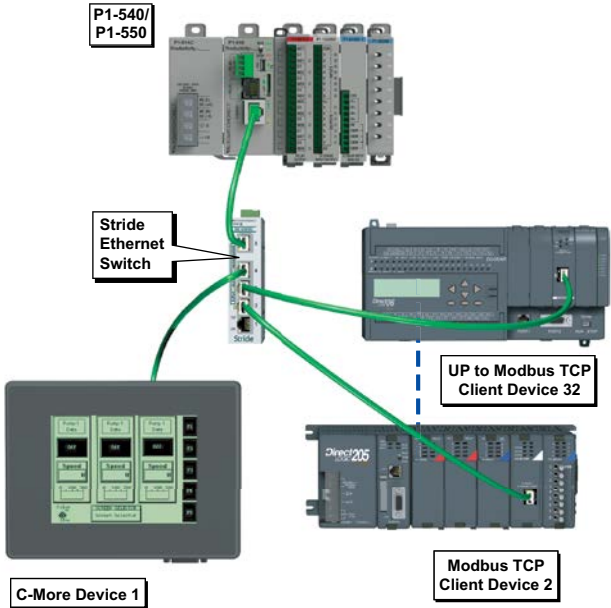

### Communication Ports, continued

Modbus TCP Server Connections: The CPU can serve data back to 16 Modbus TCP Client devices concurrently. If 16 Modbus TCP Client devices are connected to the CPU, then any new TCP connection requests will be denied until one of the existing 16 devices drops its connection. If the Client device connecting to the CPU is not a Productivity®1000 device, then a Modbus address must be assigned to the tag that is being requested. This is done in the Tag Database window. If the device connecting to the CPU is another P1000 CPU or C-more panel, no Modbus address is required.

Custom Protocol Incoming and Outgoing Communications: The Ethernet port can be used for sending and receiving non-sequenced byte arrays to various devices. This function is typically used for communicating with devices that don't support the Modbus protocol but have another custom Ethernet communications protocol. This is accomplished by configuring a "Custom Protocol Ethernet Device" using the hardware configuration and then using the "Custom Protocol Ethernet (CPE)" instruction. See Communications Connectivity section for more information.



**NOTE:** See *Communications: Port Configuration for port configuration*; *Communications: Connectivity for connection information* and *Communications: Ethernet for Ethernet setup*.

- 6 Local Ethernet: The Remote I/O Ethernet Port (Local Ethernet Network) is used for connections to 16 GS drives, 4 ProtosX couplers, 4 P1-RX remote slaves, and/or one PS-AMC module. Remote I/O is treated as local I/O by the CPU and is completely scan synchronous; except that PS-AMC modules run asynchronously with respect to the ladder scan, so AMC status bits should be used for interlocking logic if necessary. The I/O is automatically detected on power up.

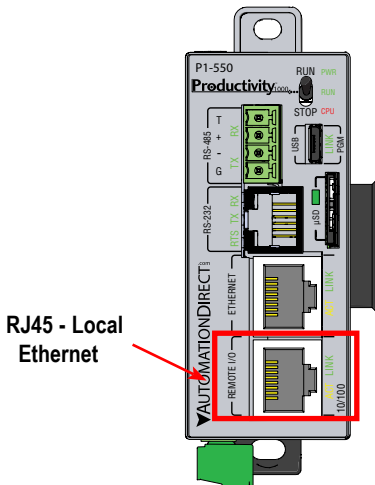

for configuration information and Communications Connectivity for connection information.

- GS Drive Devices: The P1-550 CPU can connect to 16 GS drives. It connects to a Modbus communication card added to GS4 or GS20 drives or via GS-EDRV100 modules for GS1, GS2 and GS3 series drives.
- The unique address for each GS4 or GS20 drive is set in the GSoft2 software or using the keypad on the GS4 or GS20 drive to set the last octet of the IP address.
- For the GS-EDRV100 modules, the unique address is set using the bank of DIP switches on the module.
- The P1-550 can connect to 4 ProtosX TCP couplers. The unique address for each ProtosX PX-TCP1 or PX-TCP2 module is set by assigning the last octet of the IP address at the DIP switches on the module. The P1-550 will auto-detect all GS-EDRV100 modules that have a unique address (configured by the bank of dipswitches on the module). The configuration can be managed in the Hardware Configuration in the Productivity Suite programming software. See Communications: Remote I/O and GS Drives

Communication Ports (continued)

- PS-AMC module: The P1-550 CPU can connect to one PS-AMC module. The PS-AMC module configuration is managed in the Productivity Suite programming software. See the Help File for detailed information on module configuration and instructions used with the P1-550 module. Note that PS-AMC modules run asynchronously with respect to the ladder scan, so AMC status bits should be used for interlocking logic if necessary.

Remote I/O Example

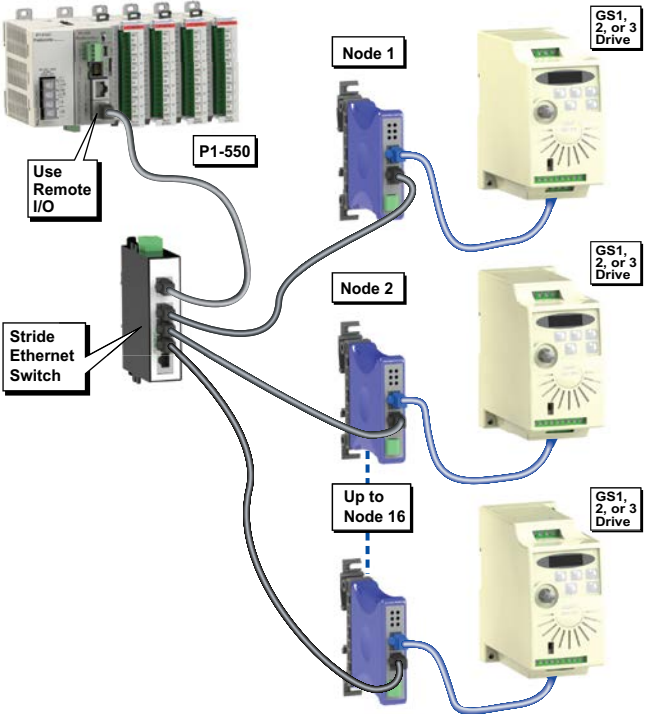

# Communications: Connectivity

## CPU Port Connections, P1-540 CPU

The AutomationDirect Productivity®1000 CPUs and PLCs are designed with several communications ports. The Connectivity for each of these ports is described in the following sections.

**1 microSD Card Slot**

For program data logging (microSD card not included with processor).

**2 MicroUSB Port**

This is a programming port with a USB 2.0 Type Micro B female connector. This port requires a MicroUSB Type A-Micro B cable (such as the USB-CBL-AMICB6 cable).

The MicroUSB Port is the simplest method of connecting the Productivity Suite Programming Software to the CPU. After the programming software has been installed, connect a USB A-Micro-B cable to the CPU and select the "Choose CPU" option. The dialog shown below will appear.

Highlight the CPU listed in the dialog box and click on "Connect". No configuration is required.

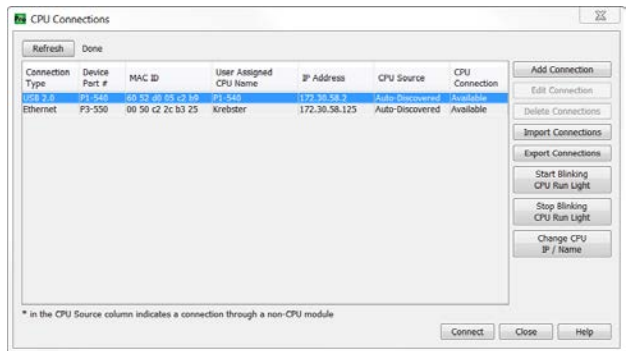
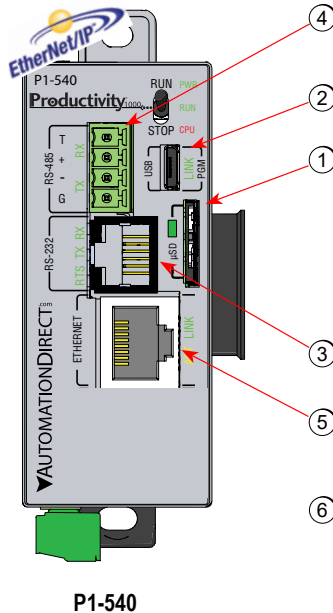

**NOTE:** The MicroUSB port is NOT compatible with older 1.0/1.1 full speed USB devices.

# Communications: Connectivity

## CPU Port Connections, P1-550 and P1-622 CPUs

The AutomationDirect Productivity®1000 P1-622 and P1-550 CPUs are provided with multiple communications ports. The Connectivity for each of these ports is described in the following sections.

**1 microSD Card Slot**

For program data logging (microSD card not included with processor).

**2 MicroUSB Port**

The P1-622 programming port is a USB 2.0 Type Micro C female connector. This port requires a MicroUSB Type A-Micro C cable (such as the **USB-CBL-AMICB6** cable). The P1-550 USB 2.0 Type Micro B female connector requires a MicroUSB Type A-Micro B cable (such as the USB-CBL-AMICB6 cable).

The MicroUSB Port is the simplest method of connecting the Productivity Suite Programming Software to the CPU. After the programming software has been installed, connect a USB A-Micro-B cable to the CPU and select the "Choose CPU" option. The dialog shown below will appear.

Highlight the CPU listed in the dialog box and click on "Connect". No configuration is required.

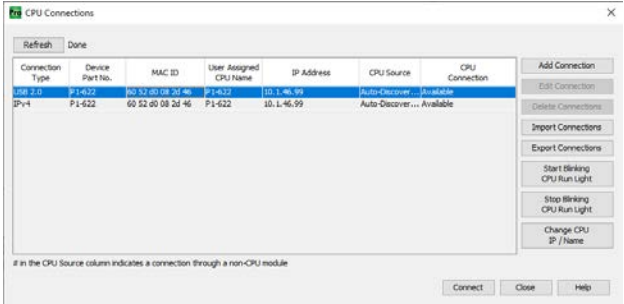
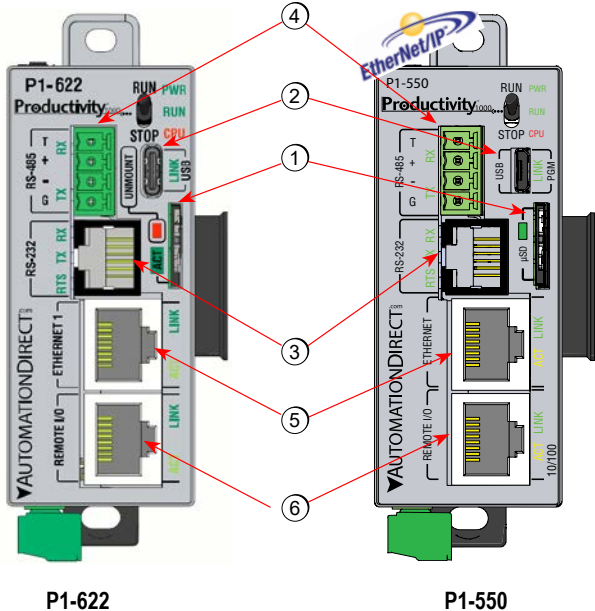

**NOTE:** The MicroUSB port is NOT compatible with older 1.0/1.1 full speed USB devices.

### 3 RS-232 Port:

Serial RS-232 multipurpose communications port with RJ12 connector.

The RS-232 Port can be connected to Modbus RTU master or slave devices, as well as devices that output non-sequenced ASCII strings or characters. The manner in which these devices are wired to the CPU depends whether the device is considered to be Data Terminal Equipment (DTE) or Data Communications Equipment (DCE).

If two DTE devices are connected together, the RX and TX signals should cross or the RX of one device should go to the TX of the other device and the TX of one device should go to the RX of the other device (as shown below).

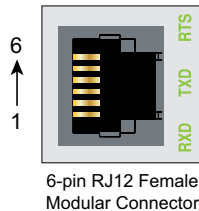

| Pin # | Signal            |
|-------|-------------------|
| 6     | GND Logic Ground  |
| 5     | RTS RS-232 Output |
| 4     | TXD RS-232 Output |
| 3     | RXD RS-232 Input  |
| 2     | +5V 210mA Maximum |
| 1     | GND Logic Ground  |

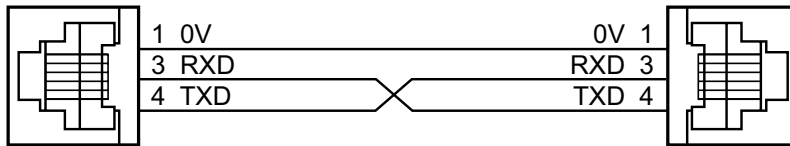

The CPU is considered a DTE device. Most Modbus or ASCII devices being connected to the CPU will also be considered a DTE device and will need to swap TX and RX, but you should always consult the documentation of that device to verify. If a communication device, such as a Modem, is placed between the CPU and another Modbus or ASCII device it will most likely require connecting the signals straight across (TX to TX and RX to RX). Again, this can differ from manufacturer to manufacturer so always consult the documentation before wiring the devices together.

The RTS signal on pin 5 of the RS-232 Port will turn on when the TX signal is turned on and the RTS signal will turn off when the TX signal turns off. The amount of time that the RTS signal turns on before the TX signal turns on and the amount of time that the RTS signal waits before turning off after the TX signal turns off is adjustable in the CPU Module Configuration for the RS-232 Port. The RTS signal is very often required for media converters, such as a RS-232 to RS-422/485 converter (much like the FA-ISOCOM).

The RTS signal is sometimes required for use with radio modems as well (Key on and off control).

There is also +5VDC @ 210mA on pin 2 available for powering an external device such as the C-more Micro panel.

**4 RS-485 Port**

The RS-485 multipurpose serial communications port requires a removable 4-pin connector (See below). This port is useful for connecting multiple Modbus and ASCII devices on one network and/or connecting devices to the CPU at distances greater than 50 feet (RS-232 limit). The RS-485 standard supports distances of up to 1000 meters without requiring a repeater. The RS-485 Port on the CPU can support up to 50 devices, depending on load of each device (this assumes a 19K Ohm load for each device). This number can be increased by placing an RS-485 repeater on the network, if necessary.

This port only supports RS-485 2-wire connections. For 4-wire RS-485 or RS-422, a converter, such as an FA-ISOCAN, should be used with the RS-232 Port.



**NOTE:** A 120 Ohm resistor is required at each end of the network for termination.



Removable connector included. Spare connectors available (part no. P3-RS485CON-1).

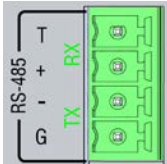

| Pin | Signal      |
|-----|-------------|
| T   | Termination |
| +   | TXD+/RXD+   |
| -   | TXD-/RXD-   |
| G   | GND         |

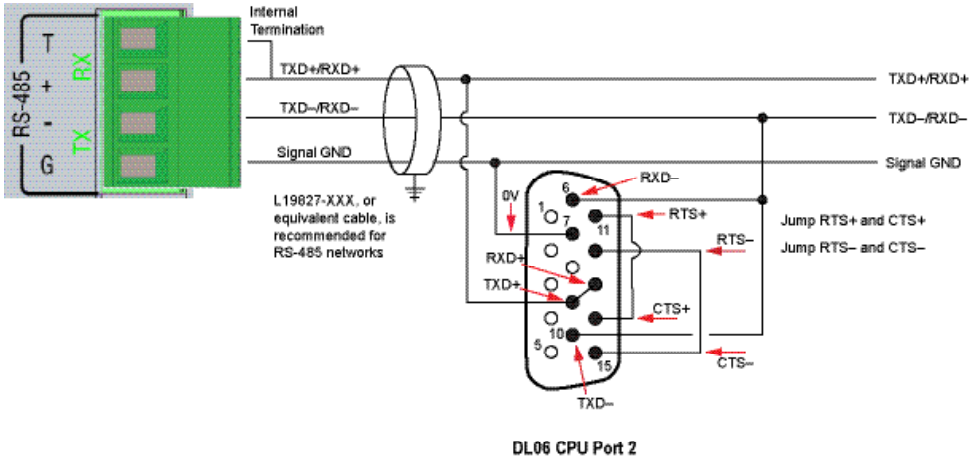

**NOTE:** ZIPLink Comm Port Adapter Part No. ZL-CMA15 or ZL-CMA15L may be used to make the connection at DL06 or DL205 CPU Port 2.

## Chapter 6: Communications

### 5 External Ethernet Port

The 10/100 Base-T Ethernet port with RJ45 connector is used for programming and Modbus TCP Client/Server functions.

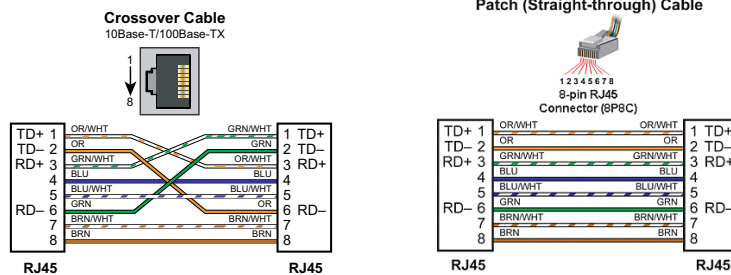

### General Information

Crossover cables can be used to directly connect two endpoint Ethernet devices such as a PC network interface card and the CPU. Crossover or patch (or Straight-through) cables can be used to directly connect endpoint Ethernet devices and the CPU.

The maximum distance for one cable or segment is 100 meters (328 feet). If the distance required between 2 devices is greater than 100 meters, add an Ethernet switch to extend the distance. An Ethernet switch can be added every 100 meters (or less) almost indefinitely. Each Ethernet switch added will incur some latency (actual amount differs between switches and manufacturers). So if a very long distance is needed between 2 Ethernet devices, it may be better to convert to fiber optics.

The External Ethernet Port can be used as a programming port, a Modbus TCP Client (16 Servers) and Server (16 Clients), EtherNet/IP Scanner (32) and Adapter (4), Custom Protocol over Ethernet, ProNET.

The External Ethernet Port can also be used to send emails using the EMAIL instruction.

### Create a Connection

Productivity Suite allows you to connect to a directly connected PLC as well as securely connecting to a remote PLC connected to a StrideLinx VPN router. To communicate with the Productivity Suite programming software, connect an Ethernet cable from the PC to the CPU External Ethernet Port. Once the software has been opened, click on CPU and select the "Choose CPU" option. The dialog shown below will appear.

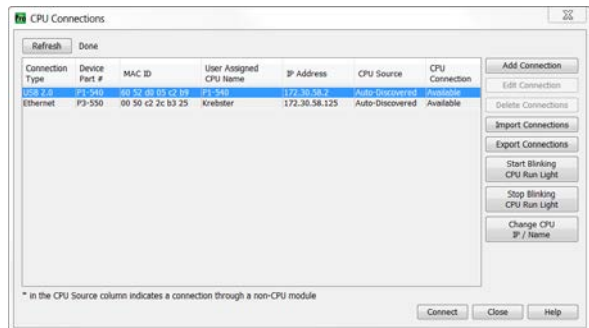

5 Ethernet Port, continued

Highlight the CPU that you wish to connect to and press the "Connect" button. You may see in the CPU Connections dialog box CPUs that are not on the same subnet as your PC, but this does not mean you can connect to them. To connect to the CPU, you must configure either your PC or your CPU to be in the same subnet. You can easily change the Ethernet settings of the CPU by highlighting it and selecting the "Change CPU IP/Name" button (shown below). Or if you prefer, the PC Setup section of this chapter contains information on configuring the Ethernet settings of your PC.

6 Local Ethernet Port

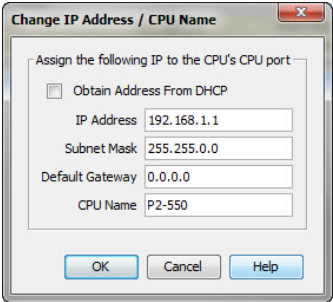

- Local Ethernet RJ45 connector supports communication with GS drives via optional GS drive communication module ProtosX TCP couplers, P1-RX remote slaves, and a PS-AMC module. The P1 Ethernet ports are auto MDI/MDI-X so straight-thru or crossover cables may be used to connect devices.

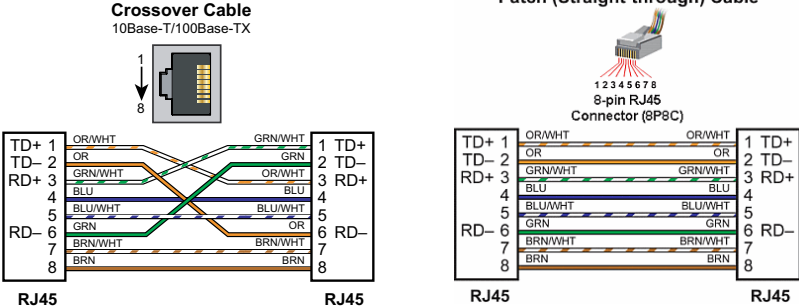

- The maximum distance for one cable or segment is 100m (328ft). If the distance required between 2 devices is greater than 100m (328ft), add an Ethernet switch to extend the distance. An Ethernet switch can be added every 100m (328ft) or less, almost indefinitely. Each Ethernet switch added will incur some latency (actual amount differs between switches and manufacturers). So if a very long distance is needed between 2 Ethernet devices, it may be better to convert to a fiber-optic system.

### ASCII and Custom Protocol Functionality

Besides Modbus RTU, there are two additional functions supported on the serial ports in the Productivity®1000 system.

- The first function is the ability to send and receive text-based data with devices such as bar code readers and serial printers.
- The second function is the ability to communicate serially with other devices that do not support the Modbus protocol and lack a Productivity1000 driver.

### ASCII Instructions

The ASCII In/Out instructions use the String data type to send or receive text-based data through the serial port. The String data type is only intended for use with the “printable character set”. This can include numbers, letters or special characters.

With the ASCII In instruction, the CPU can receive a fixed length of characters or a variable length of characters with a termination code (an ‘end of message’ character).

The ASCII Out instruction sends text-based data out of the serial port to various devices for control, printing or display.

The screenshot shows the 'ASCII Out (AOUT)' configuration window. It features a 'Serial Port' dropdown menu set to 'No ASCII Serial Port Configured'. Below it is a 'String' dropdown menu. The 'Termination' section has radio buttons for 'No Termination', '1 Character', and '2 Characters'. Under '1 Character', there are two 'Termination Code' fields, both set to '0x 0'. The 'Byte Swap Option' section has radio buttons for 'No Byte Swap', 'All Characters', and 'All But Null Characters'. A checkbox for 'Convert 0x 20 to NULL' is checked. At the bottom, there is a 'Monitor' button and 'OK', 'Cancel', and 'Help' buttons.

The screenshot shows the 'ASCII In (AIN)' configuration window. It features a 'Serial Port' dropdown menu set to 'No ASCII Serial Port Configured'. The 'Fixed Length' section has a radio button selected and a 'Number of Characters' field set to '0'. The 'Variable Length' section has a radio button selected and a 'Max Number of Characters' field set to '1'. Under '1 Character', there are two 'Termination Code' fields, both set to '0x 0'. The 'First Character' and 'Inter Character' sections each have a 'Timeout Interval' field set to '0 (0 = None)'. The 'Byte Swap Option' section has radio buttons for 'No Byte Swap', 'All Characters', and 'All But Null Characters'. A checkbox for 'Convert NULL to 0x 20' is checked. At the bottom, there is a 'Monitor' button and 'OK', 'Cancel', and 'Help' buttons.



### ASCII and Custom Protocol Functionality, continued

The Checksum option allows the user to select where in the packet the checksum should be inserted, what type of Checksum (CRC-8 bit, CRC-16 bit, CRC-32 bit, XOR-8 bit, XOR-16 bit and XOR 32 bit), which bytes of the data source should be used in the calculation of the checksum, what the byte order should be of the checksum (if greater than 8-bit) and how to preload the checksum calculation.

If the device requires a different Checksum calculation, this can be done outside of the instruction in other ladder code and the resulting Tag values can be inserted where appropriate in the packet.

Termination characters can also be specified when needed.

The Custom Protocol Out instruction is for transmission only. If information needs to be received from field devices, the Custom Protocol In instruction will have to be used. Unlike ASCII, the Custom Protocol will buffer the received data. When the Custom Protocol In instruction is executed, it will retrieve any data held in this buffer. Therefore, the lost responses found with ASCII communication do not occur with Custom Protocol communication.

#### Custom Protocol In

The Custom Protocol In instruction has similar formatting options to the Custom Protocol Out instruction.

The Custom Protocol In instruction will calculate the Checksum of the data packet received based on the criteria specified in the instruction and this will determine the state of the status bits assigned to the instruction. If the Checksum calculation passes based on the criteria specified in the instruction, the "Success" status bit will become true. If the Checksum calculation fails, the "Checksum Error" status bit will become true.

With the CPI instruction, the packet termination must be specified, either in terms of a termination character(s) or a packet length. If a Checksum is expected in the reply, be sure to include this in the Fixed Length value specified.

| Offset | Length | Data |
|--------|--------|------|
| 1      | 0      |      |
| 1      | 0      |      |
| 1      | 0      |      |
| 1      | 0      |      |
| 1      | 0      |      |
| 1      | 0      |      |
| 1      | 0      |      |
| 1      | 0      |      |
| 1      | 0      |      |
| 1      | 0      |      |

## Communications: Ethernet

### TCP and UDP Port Numbers

When doing TCP/IP and UDP/IP communications, there is a Source Port number and Destination Port number for every message. The Client device must be aware of the Destination Port Number(s) the Server device is expecting to see and the Server device must listen for this Destination Port number. After the Server device has received the message with the Destination Port Number it is listening on, it will formulate the return message (if the applications require this) with the Source Port Number from the message sent as its Destination Port Number.

It is important to understand a little about the Port numbering concept because many Ethernet devices, such as routers with firewalls, will block messages with Destination Port numbers that are not configured for that device. Listed below are the default Port Numbers used in the Productivity®1000 system. Some of these are configurable, allowing more flexibility when going through routers in many applications.

| Port   | Port Number (Decimal Format) | TCP or UDP | Configurable |
|--|------------------------------|------------|--------------|
| Programming Software CPU Discovery                           | 8888                         | UDP        | No           |
| Programming Software Connection and Project Transfer         | 9999                         | UDP        | No           |
| Modbus Client Connections (MRX, MWX, RX and WX instructions) | 502                          | TCP        | Yes          |
| Modbus Server Connections                                    | 502                          | TCP        | Yes          |
| GS-Drive Discovery   | 28784                        | UDP        | No           |
| GS-Drive Connection  | 502                          | TCP        | No           |
| Remote I/O Discovery   | 8887                         | UDP        | No           |
| Remote I/O Connection  | 8887                         | UDP        | No           |
| Email Instruction  | 25                           | TCP        | No           |
| EtherNet/IP  | 44818                        | TCP        | Yes          |
| EtherNet/IP  | 2222                         | UDP        | No*          |
| ProNET   | 18888                        | UDP        | Yes          |

\* Adapters may choose to respond using another port number.

### IP Addressing and Subnetting

IP Addresses (used in conjunction with the Subnet Mask and Default Gateway address) are used for network routing. This allows for easy and logical separation of networks.

It is outside of the scope of this user manual to explain how IP Addresses and Subnet masks are configured for actual usage. There are many books, documents and tools (Subnet calculators) on the Internet that provide this information. Each facility and network will incorporate their own rules and guidelines for how their networks are to be configured.

## Chapter 6: Communications

### PC Setup

For testing and verification purpose, it is recommended that the PC and the CPU be on the isolated Ethernet switch. Configure the PC's network interface card setting as described below.

1. Go to Start, then Run, type ncpa.cpl in the Open field and click on OK to bring up the Network Connections dialog.

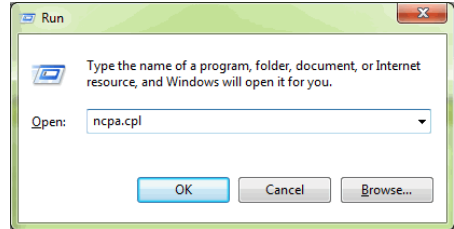

**NOTE:** Many system settings on your computer require Administrative privileges. Consult with your IT department for necessary privileges and approvals.



**NOTE:** You should record initial settings prior to making any network configuration changes.

#### 2. Network Connections

- a. Right click on the Network interface shown in the Network Connections dialog and select Properties. If there is more than one Network Interface on the PC, be sure to choose the one connected to the Ethernet Switch with the CPU on it.
- b. From the Local Area Connection Properties window, highlight the Internet Protocol(TCP/IP) selection and click on Properties.

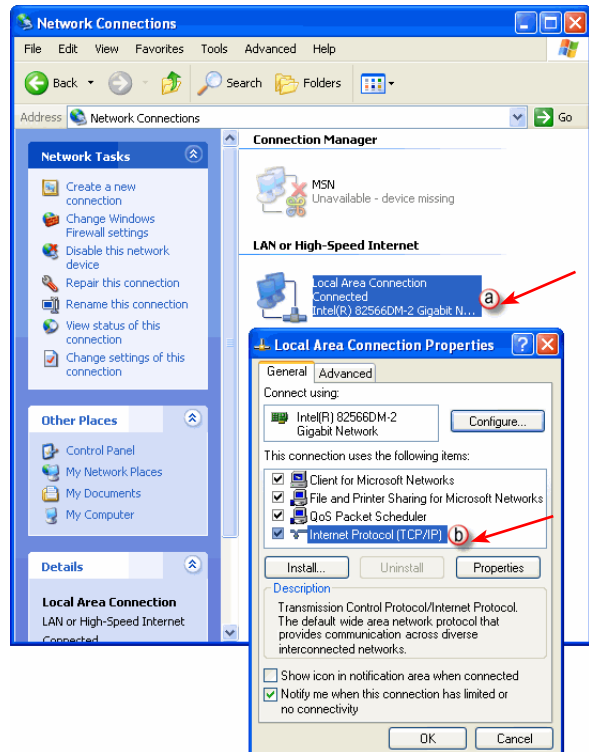

## PC Setup, continued

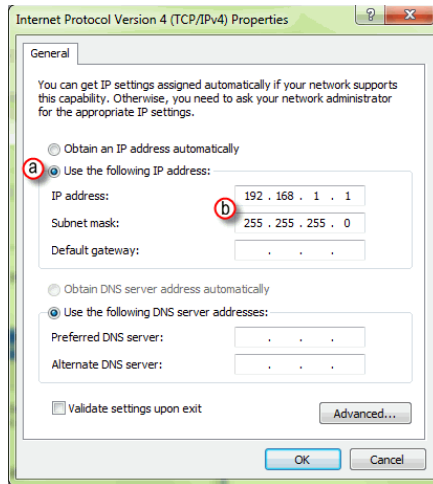

## 3. Internet Protocol (TCP/IP) Properties.

- a. In the Properties window, select Use the following IP address.
- b. Enter an IP Address of 192.168.1.1 and Subnet Mask 255.255.255.0 and select OK. Select OK again on the Local Area Connection Properties window.

## CPU Setup

Now configure the CPU's network IP setting as shown below.

1. Select CPU from the Productivity Suite Software Main Menu and then select Choose CPU from the drop down menu.
2. The CPU Connections window will open as shown below.
  - a. Click to highlight the CPU connected to the Ethernet switch.
  - b. Select the "Change CPU IP/Name" button.

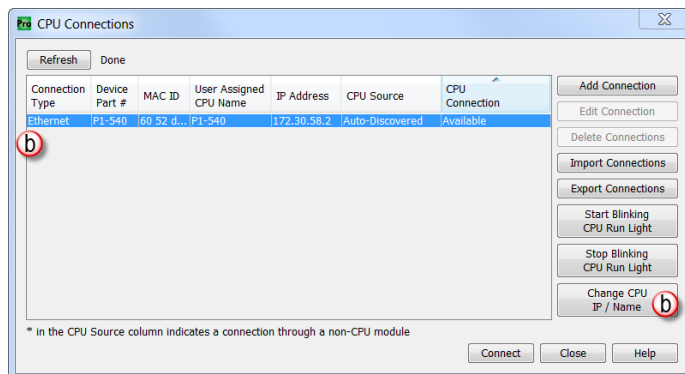

### CPU Setup, continued

3. The Change IP Address/CPU Name window will open as shown below.

- Enter an IP Address of 192.168.1.2 and Subnet Mask 255.255.0.0 for the CPU's network IP setting and select OK.

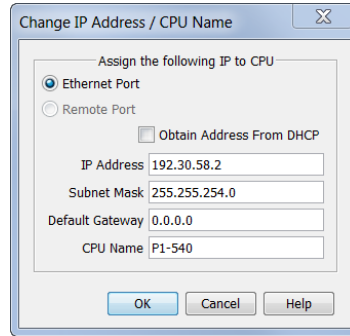

The CPU is now configured with the correct IP Address for connectivity with the PC. The IP Address and Subnet Mask settings will very likely differ from what will be used in the actual application. Consult the Network Administrator of the facility where the CPU will be installed to get the appropriate settings for that network.

### TCP Connection Behavior with Modbus TCP and Network Instructions

When performing communications over TCP, a Connection must be established before the applications can transfer data. The connection is typically maintained until the application decides that the connection is no longer needed and then the connection will be severed. Frequent connects and disconnects are not efficient for the Client or the Server and can add unnecessary network traffic. But maintaining connections needlessly is also costly to the Client and Server in terms of processing and memory so this should also be avoided.

The CPU allows user control of Client connections through enabling and disabling the rungs containing Modbus and Network instructions. The MRX, MWX, RX and WX instructions have two options for sending messages: Automatic Poll and Manual Poll.

Automatic Poll sends out messages at a specified rate. When enabled, the instruction performs a TCP connect with the Server device. Once the connection is established, the instruction messages are sent at the rate entered in the poll rate field. This continues until the instruction is disabled. The TCP connection will automatically be severed five seconds after the instruction is disabled.

Manual Poll sends out a message each time the instruction is enabled. Enabling the instruction performs a TCP connect with the Server device and sends the message one time. The TCP connection will automatically be severed five seconds after receiving the reply from the Server device. If the instruction gets another positive edge enable within the five seconds, the message will be sent and the disconnect of the TCP connection will be delayed by an additional five seconds.

## Communications Modbus Functionality

### Master/Client Function Code and Data Type Support

The following table lists the Modbus data type, the function code and the CPU source data type that is supported when the CPU is the Client or Master on a Modbus TCP or serial connection.

| Modbus Client/Master Support<br>(Using MRX and MWX Instructions) |                        |                                       |                       |   |
|--|------------------------|---------------------------------------|-----------------------|---|
| Function Code  | Function Name          | Modbus 984 Addressing<br>(Zero Based) | Modbus 984 Addressing | Productivity®1000 Tag Types<br>(Data designation or source) |
| 01   | Read Coil Status       | 000000 - 065535                       | 000001 - 065536       | Discrete Output (DO)  |
|  |                        |                                       |                       | Boolean (C )  |
|  |                        |                                       |                       | Boolean System (SBRW)                                       |
| 02   | Read Coil Status       | 100000 - 165535                       | 100001 - 165536       | Discrete Input (DI)   |
|  |                        |                                       |                       | Boolean (C )  |
|  |                        |                                       |                       | Boolean System (SBRW)                                       |
| 03   | Read Holding Registers | 400000 - 465535                       | 400001 - 465536       | Integer 8 bit Unsigned (U8)                                 |
|  |                        |                                       |                       | Integer 16 bit (S16)  |
|  |                        |                                       |                       | Integer 16 bit Unsigned (U16)                               |
|  |                        |                                       |                       | Integer 16 bit BCD (B16)                                    |
|  |                        |                                       |                       | Integer 32 bit (S32)  |
|  |                        |                                       |                       | Integer 32 bit BCD (B32)                                    |
|  |                        |                                       |                       | Integer 32 bit Float (F32)                                  |
| Integer 16 bit System (SWRW)                                     |                        |                                       |                       |   |
| 04   | Read Input Registers   | 300000 - 365535                       | 300001 - 365536       | Integer 8 bit Unsigned (U8)                                 |
|  |                        |                                       |                       | Integer 16 bit (S16)  |
|  |                        |                                       |                       | Integer 16 bit Unsigned (U16)                               |
|  |                        |                                       |                       | Integer 16 bit BCD (B16)                                    |
|  |                        |                                       |                       | Integer 32 bit (S32)  |
|  |                        |                                       |                       | Integer 32 bit BCD (B32)                                    |
|  |                        |                                       |                       | Integer 32 bit Float (F32)                                  |
| Integer 16 bit System (SWRW)                                     |                        |                                       |                       |   |
| 05   | Write Single Coil      | 000000 - 065535                       | 000001 - 065536       | Discrete Input (DI)   |
|  |                        |                                       |                       | Discrete Output (DO)  |
|  |                        |                                       |                       | Boolean (C )  |
|  |                        |                                       |                       | Boolean System (SBRW)                                       |
|  |                        |                                       |                       | Boolean System Read Only (SBR)                              |

| Modbus Client/Master Support<br>(Using MRX and MWX Instructions) (continued) |                          |                                       |                       |   |
|--|--------------------------|---------------------------------------|-----------------------|---|
| Function Code  | Function Name            | Modbus 984 Addressing<br>(Zero Based) | Modbus 984 Addressing | Productivity@1000 Tag Types<br>(Data designation or source) |
| 06   | Write Single Register    | 400000 - 465535                       | 400001 - 465536       | Integer 8 bit Unsigned (U8)                                 |
|  |                          |                                       |                       | Integer 16 bit (S16)  |
|  |                          |                                       |                       | Integer 16 bit Unsigned (U16)                               |
|  |                          |                                       |                       | Integer 16 bit BCD (B16)                                    |
|  |                          |                                       |                       | Integer 32 bit (S32)  |
|  |                          |                                       |                       | Integer 32 bit BCD (B32)                                    |
|  |                          |                                       |                       | Integer 32 bit Float (F32)                                  |
|  |                          |                                       |                       | Integer 16 bit System (SWRW)                                |
| 15   | Write Multiple Coils     | 000000 - 065535                       | 000001 - 065536       | Integer 16 bit System Read Only (SWR)                       |
|  |                          |                                       |                       | Discrete Input (DI)   |
|  |                          |                                       |                       | Discrete Output (DO)  |
|  |                          |                                       |                       | Boolean (C )  |
| 16   | Write Multiple Registers | 400000 - 465535                       | 400001 - 465536       | Boolean System (SBRW)                                       |
|  |                          |                                       |                       | Boolean System Read Only (SBR)                              |
|  |                          |                                       |                       | Integer 8 bit Unsigned (U8)                                 |
|  |                          |                                       |                       | Integer 16 bit (S16)  |
|  |                          |                                       |                       | Integer 16 bit Unsigned (U16)                               |
|  |                          |                                       |                       | Integer 16 bit BCD (B16)                                    |
|  |                          |                                       |                       | Integer 32 bit (S32)  |
|  |                          |                                       |                       | Integer 32 bit BCD (B32)                                    |
| Integer 32 bit Float (F32)   |                          |                                       |                       |   |
| 16   | Write Multiple Registers | 400000 - 465535                       | 400001 - 465536       | Integer 16 bit System (SWRW)                                |
|  |                          |                                       |                       | Integer 16 bit System Read Only (SWR)                       |

## Slave/Server Function Code and Data Type Support

The following table lists the Modbus data type, the function code and the CPU source data type that is supported when the CPU is the Server or Slave on a Modbus TCP or serial connection.

| Modbus Server/Slave Support           |                        |                       |  |
|---------------------------------------|------------------------|-----------------------|--|
| Function Code                         | Function Name          | Modbus 984 Addressing | Productivity®1000 Tag Types (Data designation or source) |
| 01                                    | Read Coil Status       | 000001 - 065536       | Discrete Output (DO)                                     |
|                                       |                        |                       | Boolean (C )   |
|                                       |                        |                       | Boolean System (SBRW)                                    |
| 02                                    | Read Coil Status       | 100001 - 165536       | Discrete Input (DI)                                      |
|                                       |                        |                       | Boolean System Read Only (SBR)                           |
| 03                                    | Read Holding Registers | 400001 - 465536       | Integer 8 bit Unsigned (U8)                              |
|                                       |                        |                       | Integer 16 bit (S16)                                     |
|                                       |                        |                       | Integer 16 bit Unsigned (U16)                            |
|                                       |                        |                       | Integer 16 bit BCD (B16)                                 |
|                                       |                        |                       | Integer 32 bit (S32)                                     |
|                                       |                        |                       | Integer 32 bit BCD (B32)                                 |
|                                       |                        |                       | Integer 32 bit Float (F32)                               |
|                                       |                        |                       | Integer 16 bit System (SWRW)                             |
| 04                                    | Read Input Registers   | 300001 -365536        | Analog Input, Integer 32 bit (AIS32)                     |
|                                       |                        |                       | Analog Input, Float 32 bit (AIF32)                       |
|                                       |                        |                       | Integer 16 bit System Read Only (SWR)                    |
| 05                                    | Write Single Coil      | 000001 - 065536       | Discrete Output (DO)                                     |
|                                       |                        |                       | Boolean (C)  |
|                                       |                        |                       | Boolean System (SBRW)                                    |
| 06                                    | Write Single Register  | 400001 - 465536       | Integer 8 bit Unsigned (U8)                              |
|                                       |                        |                       | Integer 16 bit (S16)                                     |
|                                       |                        |                       | Integer 16 bit Unsigned (U16)                            |
|                                       |                        |                       | Integer 16 bit BCD (B16)                                 |
|                                       |                        |                       | Integer 32 bit (S32)                                     |
|                                       |                        |                       | Integer 32 bit BCD (B32)                                 |
|                                       |                        |                       | Integer 32 bit Float (F32)                               |
|                                       |                        |                       | Integer 16 bit System (SWRW)                             |
| Integer 16 bit System Read Only (SBR) |                        |                       |  |
| 15                                    | Write Multiple Coils   | 000001 - 065536       | Discrete Output (DO)                                     |
|                                       |                        |                       | Boolean (C )   |
|                                       |                        |                       | Boolean System (SBRW)                                    |

| Modbus Server/Slave Support (continued) |                          |                       |  |
|---|--------------------------|-----------------------|--|
| Function Code                           | Function Name            | Modbus 984 Addressing | Productivity®1000 Tag Types (Data designation or source) |
| 16                                      | Write Multiple Registers | 400001 - 465536       | Integer 8 bit Unsigned (U8)                              |
|   |                          |                       | Integer 16 bit (S16)                                     |
|   |                          |                       | Integer 16 bit Unsigned (U16)                            |
|   |                          |                       | Integer 16 bit BCD (B16)                                 |
|   |                          |                       | Integer 32 bit (S32)                                     |
|   |                          |                       | Integer 32 bit BCD (B32)                                 |
|   |                          |                       | Integer 32 bit Float (F32)                               |
|   |                          |                       | Integer 16 bit System (SWRW)                             |
|   |                          |                       | Integer 16 bit System Read Only (SBR)                    |
|   |                          |                       | String   |

## Assigning Modbus Addresses to Tags

There are many different data types in the CPU. Because of this, the Modbus addresses need to be mapped to the various tag data types in the CPU.

There are two ways to map Modbus addresses to Tags in the Programming software:

- Modbus mapping in Tag Database window.
- Modbus mapping when creating Tags.

### 1. Modbus mapping in Tag Database window:

- There are only two data sizes in the Modbus protocol: bits and words. In the CPU, there are multiple size types, so it is sometimes necessary to map multiple Modbus addresses to a single Tag entity. There are also array data structures in the CPU. When Modbus addresses are mapped to arrays, they will be mapped as a contiguous block of addresses. This is, in fact, the most efficient method to handle Modbus communications.
- In the Tag Database window, there are two columns named "Mod Start" and "Mod End". To map a Modbus address to a tag in the Tag Database window, simply double-click in the Mod Start field for the Tag.

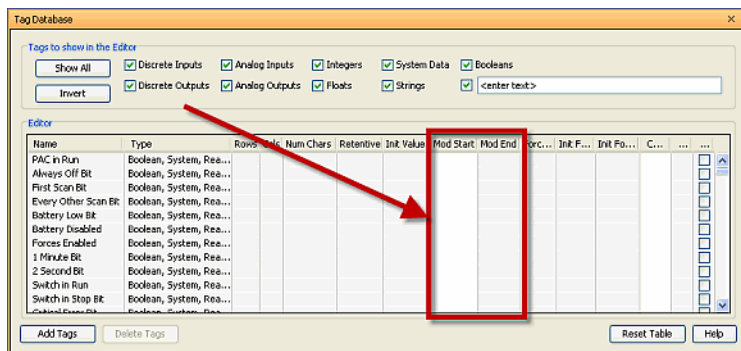

### Assigning Modbus Addresses, continued

- When this is done, two values will appear in the field The left most value is the Modbus data type. This is fixed based upon the tag data type. The chart below indicates the four different Modbus data types in the 984 addressing scheme.

| Address Identifier | Modbus 984 Address Type                   |
|--------------------|---|
| 0xxxxx             | Coil (Read/Write bit)                     |
| 1xxxxx             | Input (Read Only bit)                     |
| 3xxxxx             | Input Register (Read Only 16 bit word)    |
| 4xxxxx             | Holding Register (Read/Write 16 bit word) |

| Mod Start | Mod End | For |
|-----------|---------|-----|
| 100001    | 100001  |     |
| 100003    | 100003  |     |
| 100002    | 100002  |     |
| 000001    | 000001  |     |
| 000002    | 000002  |     |
| 000003    | 000003  |     |
| 000004    | 000004  |     |

The right most value in the "Mod Start" field is the address offset (range is from 1 – 65535). You can accept the value that is pre-filled or the value can be changed. The software automatically pre-fills the address offset with the next available address.

**Tag Database**

Tags to show in the Editor

Discrete Inputs
  Analog Inputs
  Integer

Discrete Outputs
  Analog Outputs
  Floats

Editor

| Name             | Type                       | Mod Start | Mod End |
|------------------|----------------------------|-----------|---------|
| MST-0.1.2.1      | Module Status Bit          | 100004    | 100004  |
| MST-0.1.2.2      | Module Status Bit          | 100005    | 100005  |
| MST-0.1.2.3      | Module Status Bit          | 100006    | 100006  |
| MST-0.1.2.4      | Module Status Bit          | 100007    | 100007  |
| MST-0.1.2.5      | Module Status Bit          | 100008    | 100008  |
| MST-0.1.2.6      | Module Status Bit          | 100009    | 100009  |
| MST-0.1.2.7      | Module Status Bit          | 100010    | 100010  |
| MST-0.1.2.8      | Module Status Bit          | 100011    | 100011  |
| PAC in Run       | Boolean, System, Read Only | 100012    | 100012  |
| Always Off Bit   | Boolean, System, Read Only | 100014    | 100014  |
| First Scan Bit   | Boolean, System, Read Only | 100013    | 100013  |
| Every Other Scan | Boolean, System, Read Only | 100015    | 100015  |

### Assigning Modbus Addresses, continued

#### 2. Modbus mapping when creating Tags:

- Modbus addresses can be assigned to Tags as they are created in the Tag Database.
- Type in the Modbus offset value when entering the Tag Name and Data Type.
- If the address is already assigned, a warning message will appear.

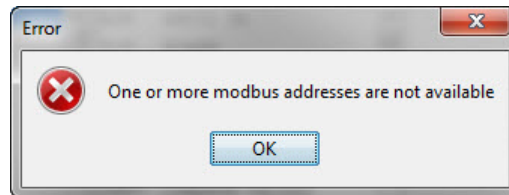
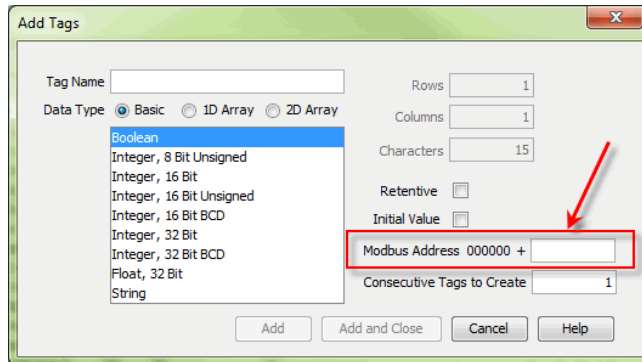

### Modbus Options

The Modbus protocol does not have a specific method outlined for data types outside of bits and 16-bit words. Most systems now have 32-bit data types. In order to transport 32-bit data types across Modbus, they must be placed into two Modbus 16-bit registers. Unfortunately, some devices do not support this method, so sometimes incompatibilities in the order in which the 16-bit high word and low word are handled between devices persist. In order to alleviate this situation, there are some options for handling this in the programming software. To find the Modbus Address options, go to File and click on Project Properties and then click on the “Modbus Server Settings” tab.

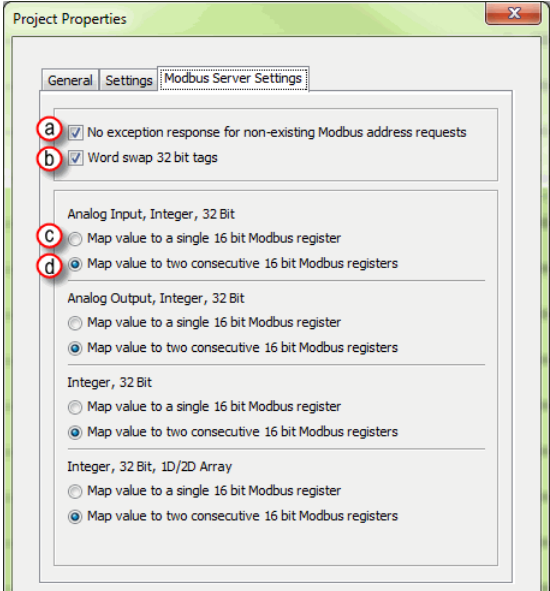

- (a) No exception response for non-existing Modbus address requests: Because the Modbus addresses can be manually assigned to tags, it is possible that gaps can occur in the Modbus address mapping. For example: Tag 1 has Modbus address 400001 assigned to it and Tag 2 has Modbus address 400003 assigned to it.

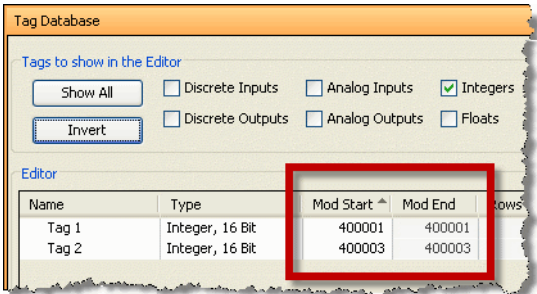

## Modbus Options, continued

Most Modbus Master/Client devices will attempt to optimize their data requests to a Modbus Slave/Server device by requesting blocks of data instead of individual registers. In the case mentioned previously, most Modbus masters would send one read request starting at 400001 and a size of three instead of sending two read requests starting at 400001 with size one and 400003 with size one as shown below.

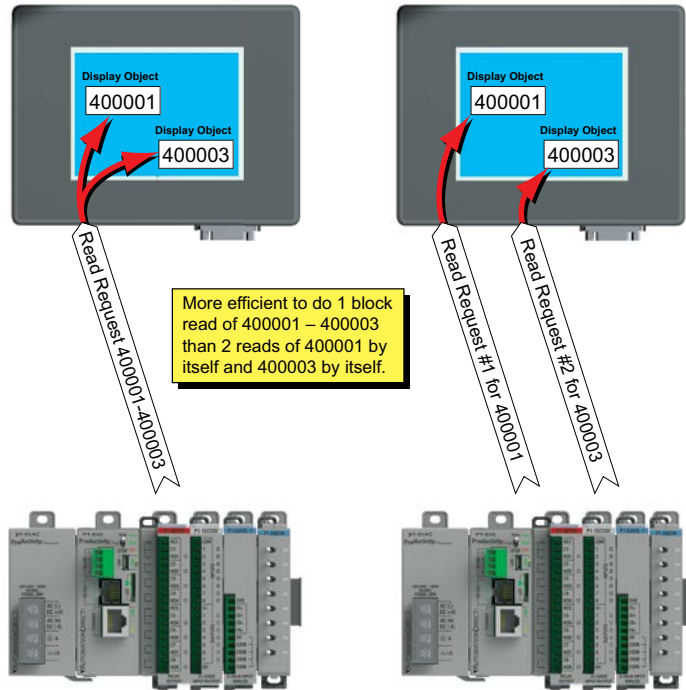

In the example shown above on left, a Modbus Slave/Server device should give an exception response since there is no Modbus Address of 400002 in the device. This method can cause a lot of inefficiencies. By selecting the “No exception response for non-existing Modbus address requests” option, the CPU will not give an exception response to the request. Note that if Modbus address 400002 by itself were requested it would give an exception response.

**b) Word swap 32 bit tags: (S-32, AIS-32, AOS-32, F-32, FI-32, FO-32):**

Word swap allows the word order of 32-bit tags to be changed when sending the values across Modbus. The default selection is on, which returns the data low word first.

Tag 1 (Integer, 32-Bit) = 305,419,896 (hex = 0x12345678)

Tag1 Modbus address = 400001, 400002

Modbus reply for Tag 1 (Word Swap ON) = 01 03 04 56 78 12 34

Modbus reply for Tag 1 (Word Swap OFF) = 01 03 04 12 34 56 78



### Modbus Options, continued

**c** Map value to a single 16 bit Modbus register:

This option allows for compatibility with devices that do not support 32-bit Modbus functionality. This option can be selected individually for the Analog Input and Output Signed 32 data types and the Internal Signed 32 data types, including the array form of these data types. This function is only useful when the value contained in a 32-bit tag does not exceed a signed 15-bit value (32,765).

Tag 1 (Integer, 32-Bit) = 22136 (hex = 0x00005678)

With "Map value to a single 16 bit Modbus register" turned OFF =

Tag 1 Modbus address = 400001, 400002

Modbus reply for Tag1 (Word Swap ON) = 01 03 04 56 78 00 00

With "Map value to a single 16 bit Modbus register" turned ON =

Tag 1 Modbus address = 400001

Modbus reply for Tag1 = 01 03 02 56 78

**d** Map value to two consecutive 16-bit Modbus registers:

Allows for 32-bit data types to be mapped to two consecutive 16-bit registers. This option is selected as default.

All of the options in the "Modbus Address" tab of the Project Properties only apply to the Modbus Slave/Server functionality. Similar options are available for the Modbus Master/Client functions as well and are available in the MRX and MWX Modbus instructions.

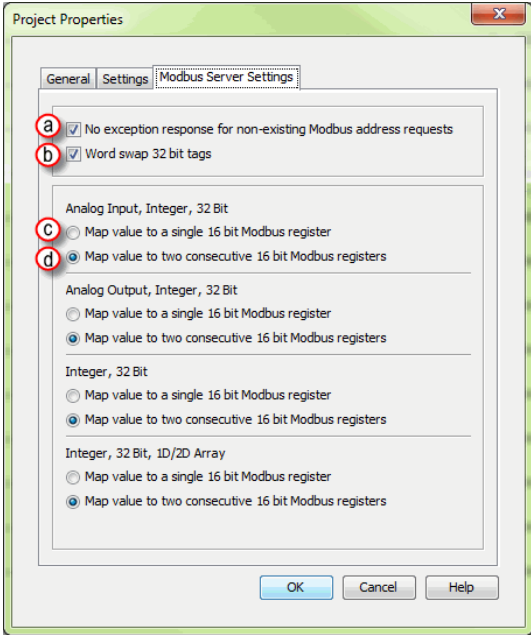

## Modbus Instructions

To read or set data in other Modbus Slave/Server devices, there are two instructions available in the programming software, Modbus Read and Modbus Write.

- The Modbus Read (MRX) instruction is used to read data from other Modbus devices into Tags of the CPU.

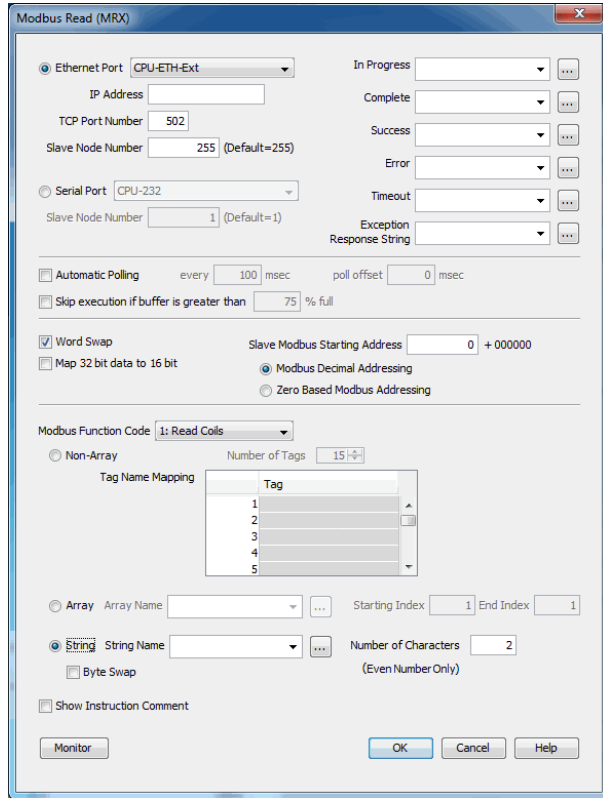

- The MRX instruction can be used for Modbus TCP or Modbus RTU. There are several status bits that can be used to determine whether the read message was successful and if it was not, the reason why.

## Modbus Instructions, continued

There is an “Automatic Polling” feature in the instruction to make it easier to read a device on a pre-determined poll rate. There is also a “poll offset” field that can be used when simultaneous instructions are enabled with the Automatic Polling feature to help stagger the flow of messages being sent to the network.

- The Modbus Write (MWX) instruction is very similar in layout and configuration to the MRX instruction. It is used to write values to a Modbus device from the tags in the CPU.

Modbus Write (MWX)

Ethernet Port: CPU-ETH-Ext  
 IP Address: \_\_\_\_\_  
 TCP Port Number: 502  
 Slave Node Number: 255 (Default=255)

Serial Port: CPU-232  
 Slave Node Number: 1 (Default=1)

Automatic Polling every 100 msec poll offset 0 msec  
 Skip execution if buffer is greater than 75 % full

Word Swap Slave Modbus Starting Address: 0 + 000000  
 Map 32 bit data to 16 bit  
 Modbus Decimal Addressing  
 Zero Based Modbus Addressing

Modbus Function Code: 5: Write Coil

Non-Array Number of Tags: 15  
 Tag Name Mapping:

| Tag |
|-----|
| 1   |
| 2   |
| 3   |
| 4   |
| 5   |

Array Array Name: \_\_\_\_\_ Starting Index: 1 End Index: 1  
 String String Name: \_\_\_\_\_ Number of Characters: 2  
 Byte Swap (Even Number Only)

Show Instruction Comment

Monitor OK Cancel Help

- The MWX operates very similarly to the MRX instruction. There are also many status bits to indicate the success or reason for failure when sending a message.
- The Automatic Polling option is also available to the MWX instruction, although greater care should be taken when using this feature in this instruction. This is explained in better detail in the “Message Queue” section.

### Network Instructions

The Network Read (RX) and Network Write (WX) instructions are used to communicate to other CPU's. They are very similar in operation to the MRX and MWX instructions but they target Tag Names instead of Modbus addresses in the other CPU. There is also a significant performance gain in using the RX and WX instructions when communicating to other CPU's as opposed to using the MRX and MWX instructions.

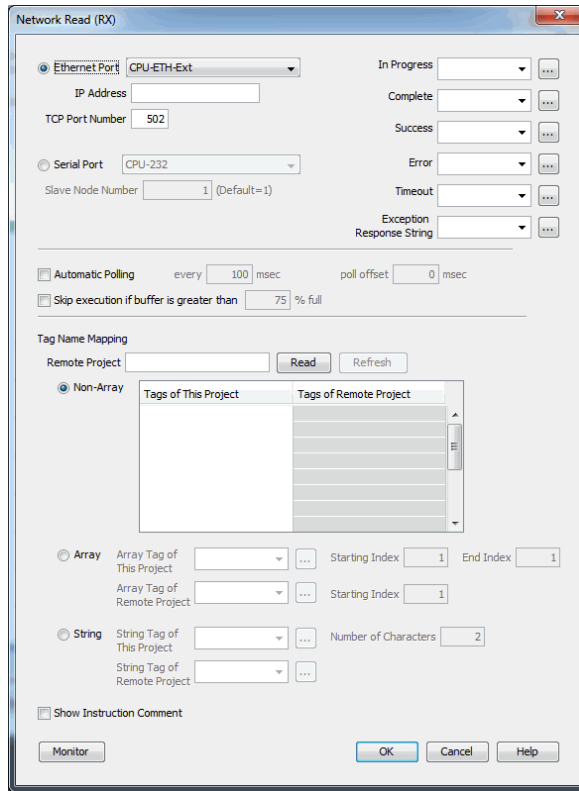

The same status bits are available in the RX instruction as in the MRX instruction and operate in the same manner. The greatest difference in the RX versus the MRX is that with the RX, the Tag Name in the target CPU can be referenced directly and does not need a corresponding Modbus address. The way this is accomplished is by mapping local and remote tagnames together within the local CPU's RX instruction. Once the instruction is set up to read a remote project, the "Tags of Remote Project" or "Array Tags of Remote Project" drop down lists will be accessible. Map the Tag of the Remote project to a Tag in the Local project to read this data.

## Network Instructions, continued

The WX instruction operates in the same manner except that the data from the Local tags will be written into the Tags of the remote project. No Modbus mapping is required.



**NOTE:** The PC programming software project for the Remote CPU must be accessible by the PC running the programming software for the Local project.

## Automatic Poll versus Manual Polling and Interlocking

In many cases when performing multiple communications requests to other devices, the message flow must be explicitly controlled in ladder code so that a message is not sent while another one is in operation. This usually requires writing 'interlocking' code between the instructions which typically involves the use of timers and shift registers, etc. Sometimes this is necessary because of the application but in other cases where the CPU just wants to read changing values from other devices and the frequency of that update is not critical it would be much more efficient to skip the unnecessary code complexity of interlocking.

The desire to make it easier to communicate to other devices brought about the "Automatic Polling" feature and the "Message Queue" in the CPU. The Automatic Polling feature allows the user to choose the rate at which messages are sent without having to use a separate timer and enabling logic. The 'Message Queue' allows the user to stage the messages from the ladder code to go out to each physical communications port without requiring interlocking logic.

## Network Instructions, continued

Read Request Flowchart

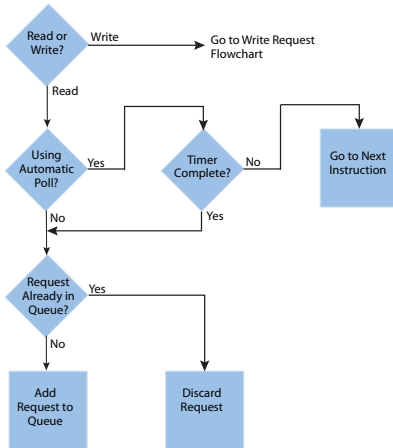

The implementation of how the message queue works is slightly different based on whether the request is a read request or a write request.

Write requests will fill the queue much faster than read requests. That's why it is advisable to carefully choose when doing write requests whether to use the "Automatic Poll" feature or to manually send write requests only when needed (data to write has changed). When designing a system, it is important to know the total time it takes to send a request and get a reply for each target device. The Poll time should be longer than this time. The longer the poll time can be, within tolerance of the application, the better the overall network performance. So for efficiency in programming and for the best possible performance for the system, conservative poll rates should be used when utilizing the "Automatic Poll" feature.

There is also a "Poll offset" field in the communications instructions. This helps prevent the instructions from being queued all at the same time. When the CPU project starts, a master timer begins. The ladder scan will look to see if the instruction is enabled. If it is enabled, it will begin the Automatic Poll timer at the specified poll offset value from the master time clock.

Write Request Flowchart

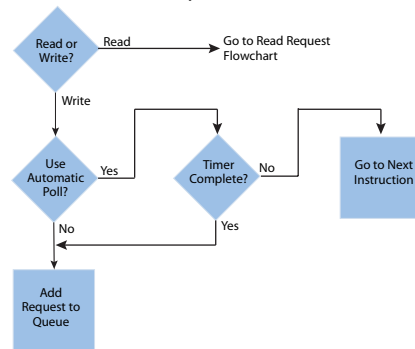

## Message Queue

If the application requires more explicit, orderly control of each message sent to the devices, turn off the “Automatic Poll” feature. Using the instruction’s status bits, logically control each message as required.

All of the above explains how messages get into the “queue”. There are several factors involved with how each queue (1 for each physical port) is emptied.

- Serial port queues: The serial port queues empty slower than the Ethernet port queues, not just because of the hardware speed itself but because of the nature of serial communications. Each request sent must wait for a response or a timeout (whichever comes first). Once the reply is received for a request or a timeout has occurred, the next item in the list can be sent. So the response time of the slave devices on the network will largely affect the speed at which the queue fills and empties.
- Ethernet port queues: The Ethernet port queue can empty faster because when sending requests to multiple devices, the CPU does not have to wait on a response from one device before sending a request to another device due to the inherent nature of the Ethernet hardware. However, sending multiple requests to the same Ethernet device does necessitate that the CPU waits for a response from the first request before sending another request to that same device.

Another difference in the Ethernet port queue versus the Serial port queue spawns from the TCP ‘connection’ based behavior of Modbus TCP. If a TCP connection is lost to a device and there are still requests in the queue for that device, those requests will be dropped from the queue. There are three ways this can happen:

1. If a TCP timeout occurs (server device fails to respond within specified timeout value), the TCP connection is lost.
2. If the server device closes the connection, then all of the requests will be dropped.
3. And, finally, if all rungs with communications instructions to a device are disabled for five seconds, the CPU will drop the TCP connection for that device in order to free up valuable resources that could be used elsewhere in the system.

This is another factor that should be considered when designing the system. If it is imperative that no message be lost when communicating to a device, each instruction should be explicitly handled one by one (interlocking logic).

# EtherNet/IP for the Productivity Series

## Terminology Definitions

A lot of terminology associated with EtherNet/IP is not always clear. Some of these terms are listed below along with their respective definitions.

1. Scanner: This is the term used to describe the device that initiates the EtherNet/IP sessions. The Scanner is sometimes referred to as the "Originator" as well. In more standard Ethernet terms, the Scanner would often be called the "Client".
2. Adapter: This is the device that responds to the EtherNet/IP communications that are initiated by the Scanner. The Adapter is also known as the "Target" as well. Typically, the Adapter is an Ethernet "Server".
3. Object: In EtherNet/IP, an Object is a representation of a defined set of Ethernet connections, behaviors, services and data attributes. There are standard objects and there are custom defined objects as well. See Object Modeling example below.
4. Class: A Class is a set of Objects that are related in some fashion. See Object Modeling example below.
5. Instance: An Instance is an actual, usable manifestation of an Object. See Object Modeling example below.
6. Attributes: Attributes are the specific items within an Object Class. The category of Attributes should be the same for all Instances of an Object but the actual Attribute itself might vary. See Object Modeling example below.
7. Connection Point: A Connection Point value is the "Class Code" reference for a data block. This value is required for access to input and output data in IO Messaging. It is typically defined for each input and output data block by the Adapter device manufacturer.
8. IO Messaging: IO Messaging (also called "Implicit Messaging") is a method of reading and writing blocks of data without defining the Connection Point and size for each block transfer. The Connection Point, size and transfer rate (RPI) are defined at the beginning and then the data blocks are transferred at the specified intervals.
9. Explicit Messaging: This method of reading or writing data requires that each message defines the type of data and size of data needed for each request.

### Object Modeling Example:

Class ----- Definition of Automobile

Attributes -- Make, Model, etc...

Object ----- A Ford Mustang

Instance ----Sally's Ford Mustang

## Network Layer Chart

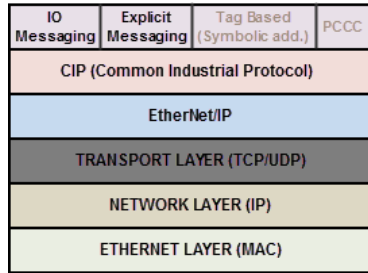

The diagram above illustrates the OSI seven layer model and how EtherNet/IP fits into this model. In general, there are three basic layers for sending and receiving data in the EtherNet/IP protocol:

- EtherNet/IP layer (Register Session, etc...)
- CIP layer (CIP Forward Open, etc...)
- The uppermost layer, which contains several different types of messaging.

The ODVA (Open DeviceNet Vendor Association) specification defines many different types of messaging that reside on the CIP layer. Two types of messaging supported in the phase 1 release of the Productivity Series EtherNet/IP protocol are I/O Messaging and Explicit Messaging. I/O Messaging is accomplished through a Class 1 Connection and Explicit Messaging can be accomplished through a Class 3 Connection or an Unconnected Message.

Tag Based Messaging (used for reading and writing values to Allen Bradley Control and CompactLogix PLCs) and PCCC (used for reading and writing values to Allen Bradley MicroLogix and SLC PLCs) are planned for subsequent phases of this protocol.

### EtherNet/IP Data

When doing I/O Messaging, the data that is transported is defined as “Input” data and “Output” data. Don’t confuse this type of data with what most PLCs define as Input data and Output data. In most PLCs, Inputs are typically associated with an Input module that reads points from real word devices. Outputs are typically associated with an Output module that turns off and on real word devices.

In I/O Messaging, Input data is data that is sent from the target device back to the Originator or to multiple devices that are listening (multicast messages). Output data is data that is sent from the Target device. This data may or may not be connected to real word devices. That is completely dependent upon the Adapter device. For example: When the Productivity®1000 is configured as an EtherNet/IP Adapter device, the Input data and Output data is defined in internal data arrays and does not directly tie to any Input and Output point to the real world. If it is desired to tie these array elements to real word devices, that must be accomplished in code by Copy commands (or other instructions).



**NOTE:** The Scanner (originator) in the P1000 will only accept messages from an Adapter (target) device with an established connection with a Scanner. The Adapter (target) in the P1000 will respond back to a Scanner (originator) in the method (Multicast or Unicast) that is sent in the forward open message from the Scanner (originator).

## Chapter 6: Communications

### Class 1 and Class 3 Connections

What are they and how are they best used?

- Class 1 Connection is the transport mechanism that IO Messaging uses to send data. The basic concept is that data is sent in one direction: the Originator sends Output data in a Unicast UDP message to the Target and the Target sends Input data in either a Unicast message back to the Originator or Multicast UDP messages to multiple devices. The Input data and Output data messages have no relationship to each other. This method works well for Remote I/O type data and is very efficient due to little overhead and reduced handshaking messages on the wire. Class 3 Connection is one of the mechanisms that Explicit messaging uses. Class 3 messaging uses TCP messages unlike Class 1. Each Class 3 request has a header that defines the type of data requested as well as the size requested. It allows for more flexibility in messaging but does create additional overhead.



**NOTE:** Explicit messaging can be accomplished with unconnected messages as well for more infrequent requests. Explicit messaging is a slower performing method of communications but it typically allows for more flexibility and control when the situation requires it.

When can the P1000 CPU use Class 1 or Class 3 Connections?

- Class 1 and Class 3 Connections can be accomplished with the Productivity®1000 CPU as an Adapter or as a Scanner or both simultaneously.

How many connections can the Productivity1000 support for EtherNet/IP?

- 4 - TCP
- 4 - EtherNet IP
- 4 - CIP (Up to 4 CIP connections are allowed per EtherNet/IP connection. Therefore, if one device can support 4 CIP connections then you can have up to a total of 16 CIP connections using 4 devices)

### Setup Example 1: Productivity®1000 as EtherNet/IP Adapter

The Adapter setup is accomplished through the EtherNet/IP Adapter setup under the Comm Adapter Config section of the Setup menu as seen on right.

When the EtherNet/IP Adapter is selected from the menu, the window shown here will open.

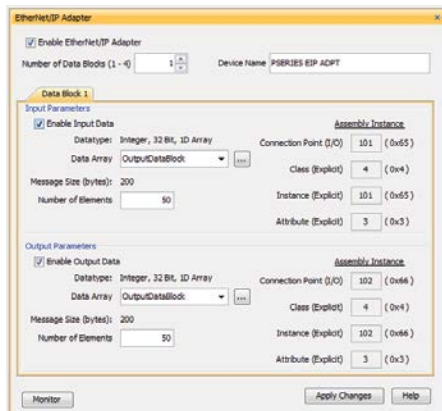
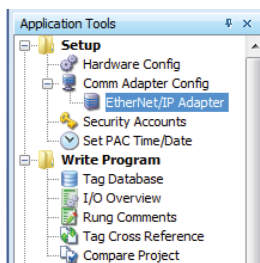

Fill in the required parameters and once configured these parameters will be used to configure the Scanner side as shown in the examples below. The first example shows how to setup a Class 1 IO Message connection from a 3rd party EtherNet/IP Scanner device (an Allen Bradley PLC).

RS Logix5000 Control/CompactLogix Generic Ethernet Device Setup

The screenshot displays the configuration for an Ethernet Module and an EtherNet/IP Adapter. In the 'Module Properties' dialog, the 'Connection' tab shows the following settings:

- Type: ETHERNET-MODULE Generic Ethernet Module
- Vendor: Allen-Bradley
- Parent: LocalENB
- Name: P3000\_1
- Description:
- Comm Format: Data - INT
- Connection Parameters:
  - Input: 101 (Size: 50 (16-bit))
  - Output: 102 (Size: 50 (16-bit))
  - Configuration: 1 (Size: 0 (8-bit))

The 'EtherNet/IP Adapter' dialog is also shown, with the following settings for 'Data Block 1':

- Enable EtherNet/IP Adapter:
- Number of Data Blocks (1 - 4): 1
- Device Name: P3K E/IP Adapter
- Input Parameters:
  - Enable Input Data:
  - Datatype: Unsigned Int 16 ID Array
  - Data Array: InputDataBlock
  - Message Size (bytes): 100
  - Number of Elements: 50
  - Connection Point (I/O): 101 (0x65)
  - Class (Explicit): 4 (0x4)
  - Instance (Explicit): 101 (0x65)
  - Attribute (Explicit): 3 (0x3)
- Output Parameters:
  - Enable Output Data:
  - Datatype: Unsigned Int 16 ID Array
  - Data Array: OutputDataBlock
  - Message Size (bytes): 100
  - Number of Elements: 50
  - Connection Point (I/O): 102 (0x66)
  - Class (Explicit): 4 (0x4)
  - Instance (Explicit): 102 (0x66)
  - Attribute (Explicit): 3 (0x3)

The following example shows how a Class 3 Explicit Message might be accomplished from a 3rd party device (Allen Bradley PLC). As you can see the Input Data must be retrieved in one connection or message and the output data in another. Remember that Class 3 messaging is not as efficient in protocol messaging as Class 1 but it does allow for granular control.



**NOTE:** In this example, size configuration is not shown on the Scanner side. The tag created for the Destination must be large enough to contain the data requested (shown with dashed boxes).

# Chapter 6: Communications

RS Logix5000 MSG instruction for Control/CompactLogix

The image displays three screenshots of software configuration windows, illustrating the configuration of the MSGtoP3 instruction and the EtherNet/IP Adapter.

**Message Configuration - MSGtoP3 (Top Window):**

- Message Type: CIP Generic
- Service Type: Get Attribute Single
- Service Code: e (Hex)
- Class: 4 (Hex)
- Instance: 101
- Attribute: 3 (Hex)
- Destination: P3InputData

**Message Configuration - MSGtoP3 (Middle Window):**

- Message Type: CIP Generic
- Service Type: Set Attribute Single
- Service Code: 10 (Hex)
- Class: 4 (Hex)
- Instance: 102
- Attribute: 3 (Hex)
- Source Element: P3OutputData
- Source Length: 100 (Bytes)

**EtherNet/IP Adapter (Bottom Window):**

- Enable EtherNet/IP Adapter:
- Number of Data Blocks (1 - 4): 1
- Device Name: P3K E/IP Adapter
- Data Block 1:
  - Input Parameters:
    - Enable Input Data:
    - Datatype: Unsigned Int 16 1D Array
    - Data Array: InputDataBlock
    - Message Size (bytes): 100
    - Number of Elements: 50
  - Output Parameters:
    - Enable Output Data:
    - Datatype: Unsigned Int 16 1D Array
    - Data Array: OutputDataBlock
    - Message Size (bytes): 100
    - Number of Elements: 50
  - Assembly Instance:
    - Connection Point (I/O): 101 (0x65)
    - Class (Explicit): 4 (0x4)
    - Instance (Explicit): 101 (0x65)
    - Attribute (Explicit): 3 (0x3)

### Example 2: Productivity® 1000 as EtherNet/IP Scanner

This example shows how to connect the Productivity1000 Scanner function to an EtherNet/IP adapter device using Class 1 I/O Messaging. First, create an EtherNet/IP device in the Hardware Configuration as seen below:

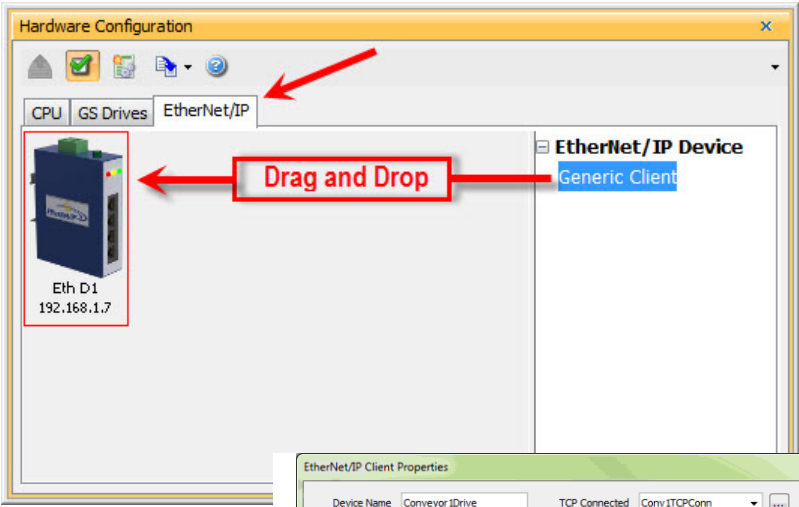

Configure the parameters to match the settings of the Adapter device. The image on right shows the setup of the Input data.

The size, in this case, is dynamic to the configuration of the device. For this particular example, we configured the device in a manner that allows it to publish 8 bytes of data for Input. Many devices will have a fixed configuration that should be published in the manufacturer's documentation.

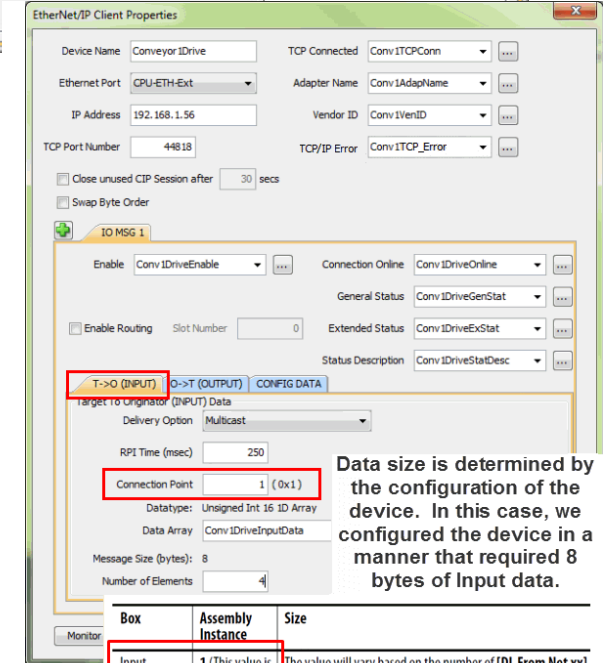

Data size is determined by the configuration of the device. In this case, we configured the device in a manner that required 8 bytes of Input data.

| Box           | Assembly Instance           | Size  |
|---------------|-----------------------------|---|
| Input         | 1 (This value is required.) | The value will vary based on the number of [DL From Net xx] parameters used for your application (see details below). |
| Output        | 2 (This value is required.) | The value will vary based on the number of [DL To Net xx] parameters used for your application (see details below).   |
| Configuration | 6 (This value is required.) | 0 (This value is required.)   |

# Chapter 6: Communications

The Output data must also be configured. Its data is also dynamic based upon the configuration. In our example, we configured the device in a manner that caused it to require 8 bytes of Output data.

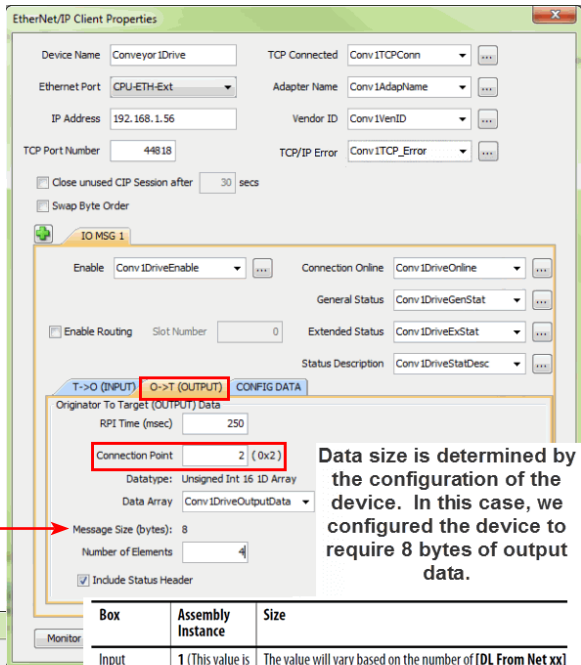

Data size is determined by the configuration of the device. In this case, we configured the device to require 8 bytes of output data.

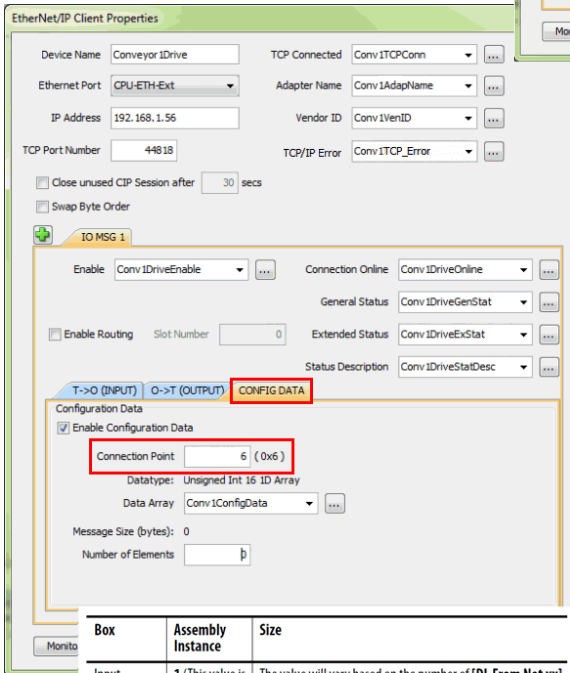

| Box           | Assembly Instance           | Size  |
|---------------|-----------------------------|---|
| Input         | 1 (This value is required.) | The value will vary based on the number of [DL From Net xx] parameters used for your application (see details below). |
| Output        | 2 (This value is required.) | The value will vary based on the number of [DL To Net xx] parameters used for your application (see details below).   |
| Configuration | 6 (This value is required.) | 0 (This value is required.)   |

The image on left shows the setup for the Configuration data. The Configuration data, for most devices, is a fixed size. Some devices will require that the Configuration data Connection Point be included in the Forward Open message (as shown on left) even if the size is 0. Some devices will require that the Configuration data Connection Point not be in the Forward Open and the checkbox option in the image below would need to be de-selected.

| Box           | Assembly Instance           | Size  |
|---------------|-----------------------------|---|
| Input         | 1 (This value is required.) | The value will vary based on the number of [DL From Net xx] parameters used for your application (see details below). |
| Output        | 2 (This value is required.) | The value will vary based on the number of [DL To Net xx] parameters used for your application (see details below).   |
| Configuration | 6 (This value is required.) | 0 (This value is required.)   |

The following example shows how to connect the Productivity1000 Scanner function to an EtherNet/IP Adapter device using Class 3 Explicit Messaging. As with IO Messaging, an EtherNet/IP device must be created in the Hardware Configuration as seen below:

Explicit Messages can be performed in 2 ways: Unconnected or Connected (Class 3). The advantage of using Unconnected messaging is it allows more discrete control of each request. The disadvantage of Unconnected messaging is that Unconnected messages have a lower priority and will take longer to get serviced on some devices. Connected messages get serviced faster since there is a connection established to the device. If Connected messaging is desired, create an Explicit Message tab as shown in the image above. If Unconnected messaging is desired, do not create an Explicit Message tab. Only fill out the information in the upper portion of the EtherNet/IP Client Properties window.

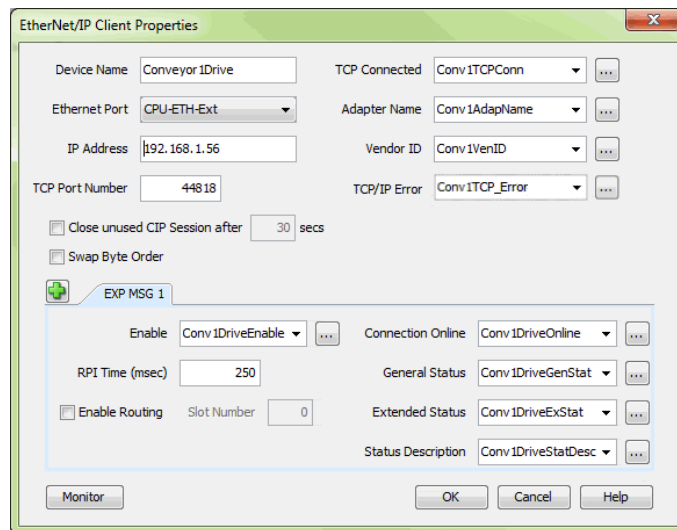
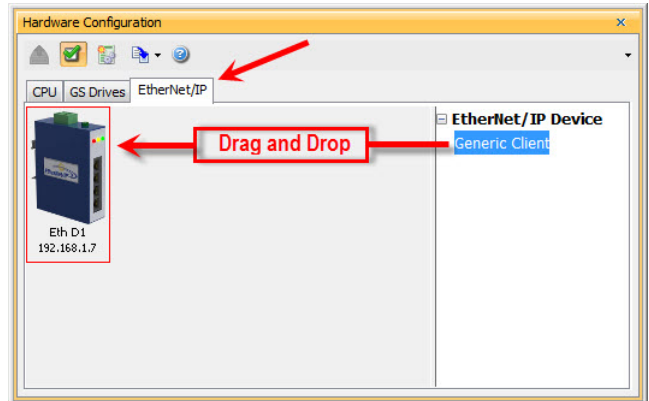

Once the desired parameters have been entered, the device may now be referenced in the Explicit Message Instruction. If Unconnected messaging has been selected, choose the Unconnected MSG option in the Connection drop down box. If Connected messaging has been selected, choose the Explicit Message that was configured in the EtherNet/IP Client Properties window in the Connection drop down box. The rest of the settings should be matched to the specifications documented by the manufacturer.

An example for requesting the Identity of a device is shown below. The data array configured for this function must be sufficient in size to hold the returned data from the device for this object. Data can also be written to the device if it supports an object for this purpose. If data is being written, enable the Output selection and specify the data array and size required by that device's object.

### Troubleshooting Tips:

1. Use the diagnostic tags in the Hardware Configuration and Explicit Message Instruction: As explained previously in the Network Layer Chart section, there are multiple layers of messaging involved with EtherNet/IP. If it appears that the Productivity1000 is not communicating with another EtherNet/IP device, there are diagnostic tags available to narrow down which layer of the protocol is preventing successful communications.
  - a. At the TCP layer, there is a TCP Connected field that will expose the status of the TCP/IP connection when a tag is populated in this field.

**Identity Object**

**Services**

| Service Code | Class | Instance | Service Name         |
|--------------|-------|----------|----------------------|
| 0x05         | No    | Yes      | Reset                |
| 0x0E         | Yes   | Yes      | Get_Attribute_Single |
| 0x01         | Yes   | Yes      | Get_Attributes_All   |

**Class Code**

| Hexadecimal | Decimal |
|-------------|---------|
| 0x01        | 1       |

**Class Attributes**

| Attribute ID | Access Rule | Name         | Data Type | Description               |
|--------------|-------------|--------------|-----------|---------------------------|
| 2            | Get         | Max Instance | UINT      | Total number of instances |

**Instances**

The number of instances depends on the number of components in the device connected to the adapter. This number of components can be read in Instance 0, Attribute 2.

| Instance | Description                 |
|----------|-----------------------------|
| 0        | Class                       |
| 1        | Host                        |
| 2...15   | Peripherals on Ports 1...14 |

- b. There is an Adapter Name field for a String tag and a Vendor ID field for an Integer tag. Both of these fields can help to identify whether the Productivity1000 is connected to the correct device or not.
- c. At the CIP layer, there is a Connection Online field for a Boolean tag.

- d. There are three additional fields to help determine why the CIP session might not be successful: General Status for an Integer tag, Extended Status for an Integer Data Array and Status Description for a String tag.

### 2. Use the TCP connected tag:

First check the TCP Connected tag. If the connection has been enabled (by turning on the tag configured in the Enable field or triggering an Explicit Message instruction with an Unconnected MSG specified) and the TCP Connected tag is not true, check the following items:

- a. Cabling. Ensure that all of the cables are connected and in good shape. In most cases, the Ethernet port that the cable is connected to should indicate a Link Good LED. Ensure that any interim Ethernet switches are powered up and functioning and that the end device is powered up and functional.
- b. IP address and correct subnet. Check that the IP address entered into the IP Address field is the correct address for the device that you are connecting to. Also check that the EtherNet/IP device's IP address and subnet mask is compatible with the IP address and subnet mask of the Productivity1000. If there are any routers in between the two, ensure that a proper default gateway that matches the router's IP address is configured. If you are unfamiliar with proper IP addressing and subnet configuration, consult with the network administrator for guidance.
- c. TCP Port number. The default listening TCP port number for EtherNet/IP is 44818. Check that the target device is listening on this specific port number. If it is not, change the value in TCP Port Number field to the appropriate value. If there are interim router devices that are using port forwarding, ensure that the router is properly configured for this setup.



---

**NOTE:** Attempting to do IO Messaging across routers (different subnets) is unlikely to be successful. IO Messaging uses multicast messaging in many cases and the Port number is not necessarily fixed when the IO Messaging is established (the Forward Open message has the ability to 'negotiate' the port number used for the IO Messages).

---

- d. Adapter Name and Vendor ID. If the network contains many EtherNet/IP devices and these devices may not necessarily be connected to the Productivity1000, it may be a good safeguard to check the Adapter Name and Vendor ID returned and verify that these devices are the correct devices to which it is connected.

### 3. Use the Connection Online and Error tags:

If the TCP Connected tag is true and the Adapter Name and Vendor ID look correct, the next tags to look at are the Connection Online, the General Status, the Extended Status and the Status Description.

If the Enable tag is true and the Connection Online tag is not true, check the General Status value along with the Extended Status value(s) and the Status Description. If the General Status value and the Extended Status value(s) are part of the defined errors from the ODVA specification, the Status Description should also return a more descriptive String. Once these errors are known, it may be possible to very simply make the adjustment in the settings to correct the issue.

## Chapter 6: Communications

If it is not obvious from the description, first check the manufacturer's documentation for corrective action in this particular scenario.

If the manufacturer's documentation doesn't give corrective action, check the EtherNet/IP Error Code List in this chapter for possible solutions.



---

**NOTE:** *This may not always solve the problem as each device manufacturer may publish the error for slightly different reasons.*

---

If the Connection Online tag is true and the data being received is different than what is expected, verify that the correct Connection Point values and/or Class, Instance, Attribute values are configured. There may be multiple areas of available data in that device. Verify that the correct data types are being used for both sides. If the data types are mismatched, this may make the data 'appear' to be incorrect.

Another great tool that can be used is Wireshark. Wireshark is a free network analyzer tool that can be downloaded from [www.wireshark.com](http://www.wireshark.com).



---

**NOTE:** *Using this tool implies some knowledge of how networking protocols function. Using Wireshark will also require that you have a true Ethernet hub (not an unmanaged switch) or a managed switch with Port mirroring capability.*

---

You may also use the following basic steps to check your EtherNet/IP Setup.

### EtherNet/IP I/O Message Troubleshooting:

1. Does the IP Address set up in the Scanner match the Adapter IP Address?
2. Is the enable tag entered into the Scanner turned ON?
3. Does the connection point entered into the I/O Message Data Block match the connection point of the Adapter?
4. Does the number of elements match the Adapter?
5. Does the data type match the Adapter?
6. Steps 4 & 5 are important because the number of bytes being read from or written to the Adapter have to match the Adapter bytes allocated.

### EtherNet/IP Explicit Message Troubleshooting:

1. Does the IP Address set up in the Scanner match the Adapter IP Address?
2. Is the enable tag entered into the Scanner turned ON when not using the Unconnected MSG connection type?
3. Make sure the logic for the EtherNet/IP Explicit Message (EMSG) is TRUE so the instruction is enabled.
4. When using Get or Set single attributes in the Service field make sure the Instance ID matches the Instance ID of the Adapter.
5. When using Generic in the Service field make sure the Service ID, Class ID, Attribute ID and Instance ID match the Adapter settings.
6. Does the number of elements match the Adapter?
7. Does the data type match the Adapter?

Steps 6 & 7 are important because the number of bytes being read from or written to the Adapter have to match the Adapter bytes allocated.

## ProNET

Productivity Network (ProNET) provides the ability to share data with other P-Series CPU's, This can easily be accomplished using the Productivity Network (PNET) setup in the Hardware Configuration window used to join a data sharing network consisting of other P-Series controllers.

Each member of the data sharing network receives data from all of the other P-Series controllers on that data sharing network. Each node can optionally send data to the other nodes of the data sharing network by electing to "publish" data.

The ProNET configuration uses UDP broadcast packets to publish the blocks of data to the network. One caveat with the use of broadcast packets is that it limits the scope of the shared data network to the local broadcast domain.

ProNET uses the verbs 'publishing' and 'subscribing' to describe how the controller data is exchanged with other P-Series controllers on the data sharing network.

Publishing is analogous to sending data, and is done only if ProNET is configured to 'publish' one or more of its assigned tags. If so configured, the P-Series controller will broadcast a packet that contains the data from the selected tags.

Subscribing is analogous to receiving data, and is accomplished by 'subscribing to' a publisher's global ID of any P-Series CPU on the data sharing network set up to publish its data.

The ProNET configuration works with a 1D array tag(s) that can contain up to 65535 elements, however you are limited to 32 total 32-bit elements, 64 total 16-bit elements, or 128 total 8-bit or Boolean elements of data per publisher array data type. These tags provide the local storage for the data sent and received over the data-sharing network.

When the input logic to the ProNET configuration is Enabled, it operates at a fixed rate of 10 times per second (100ms). The instruction will publish all of the elements of the array that it is configured to publish, and will process any ProNET nodes that it receives. When

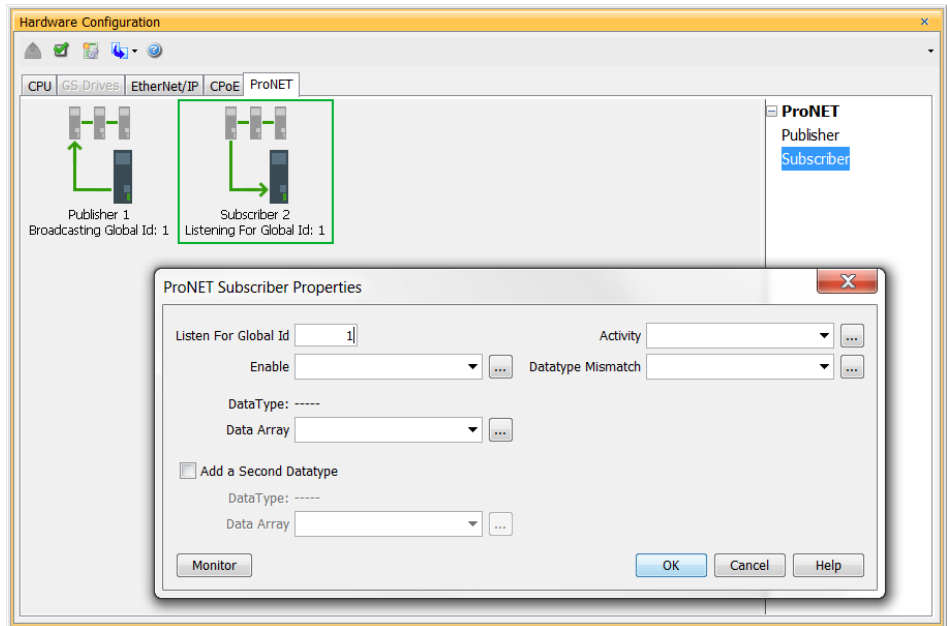

## Chapter 6: Communications

the input logic is OFF, (the device is disabled), it DOES NOT publish any of its tags and DOES NOT process any ProNET nodes that it receives.

### Custom Protocol over Ethernet Functionality



**NOTE:** The message size for each data type is limited to 128 bytes regardless of the defined array size.

| Data Type      | Number of Elements |
|----------------|--------------------|
| Boolean        | 128                |
| Integer 8-Bit  | 128                |
| Integer 16-Bit | 64                 |
| Integer 32-Bit | 32                 |
| Integer 64-Bit | 32                 |

Besides Modbus RTU, EtherNet/IP, and ProNET the Productivity®1000 system has the ability to communicate via Ethernet with other devices using the Custom Protocol over Ethernet (CPoE).

#### Custom Protocol over Ethernet

The Custom Protocol is a HEX based protocol used to communicate with devices that do not support one of the other protocols on Productivity1000. There are two steps to initiate communications via the Custom Protocol over Ethernet:

- First you must set up a device in the hardware configuration under the CPoE tab.
- Then you must use the Custom Protocol Ethernet( CPE) instruction to initiate messages.

## Hardware Configuration

First you must set up a device to talk to in the CPoE tab of the hardware configuration. This will require you to:

- ① Enter a Device Name
- ② Enter the IP Address of the device you wish to communicate with.

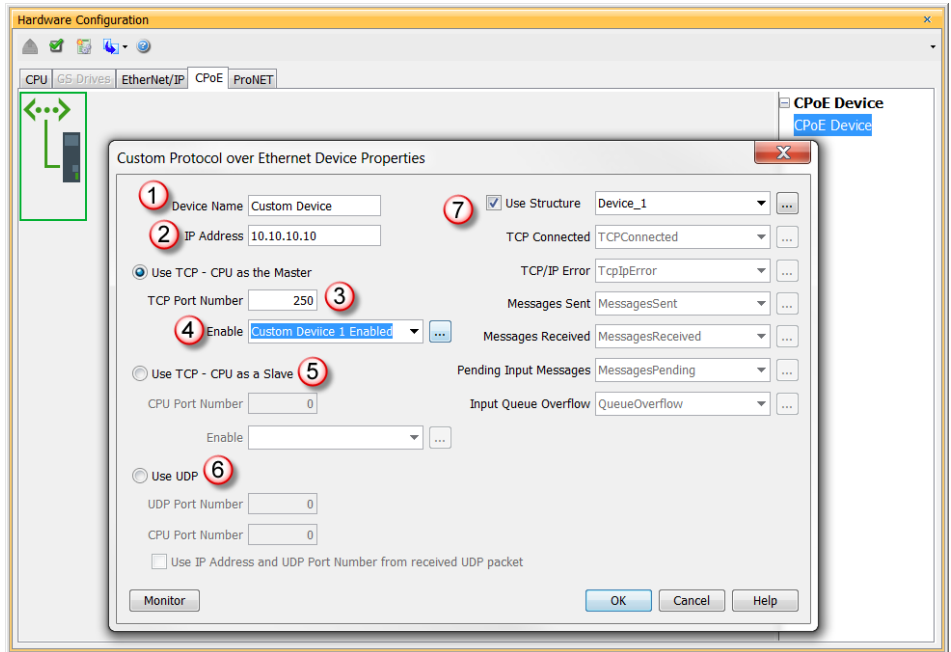

- ③ Enter the port number of the device.
- ④ Enter an Enable tag to enable the device if using TCP.
- ⑤ Choose whether you wish to Use the PLC as the master or the slave device via TCP connection
- ⑥ Choose whether you wish to use a UDP connection.
- ⑦ Enter tags for status of this device for troubleshooting (Example below shows the Structure method used).

### Custom Protocol Ethernet Instruction

Next you must use the Custom Protocol Ethernet instruction in ladder.

- The instruction can be chosen Receive or Send messages to the Custom Device.
- The user can choose to use:
  - a. A table with tags that allow the user to send a specific data.
  - b. An array tag that is numerical can be used to Send/Receive from.
  - c. A string tag that contains an ASCII string to be sent or string location to receive characters to.

# Communications: Remote I/O and GS-Drives

## Design Considerations for Remote I/O and GS-Drives

It is important to understand that only one Remote I/O network can be on an unmanaged switch. If two or more Remote I/O networks are mixed into the same physical LAN (local area network), duplicate IP addressing will occur and the system will not function properly. Multiple Remote I/O networks can be used on a managed switch using the VLAN feature to create a virtual separation of the different networks, but multicasting messages are necessary for the network to function properly. Care must be taken when designing a system this way (using a managed switch). Even if only one Remote I/O network is being used in a facility, it is strongly recommended to keep it on a dedicated network, physically isolated from other networks. The Productivity®1000 Remote I/O network makes use of multi-casting messages and many devices will not function properly in this situation.

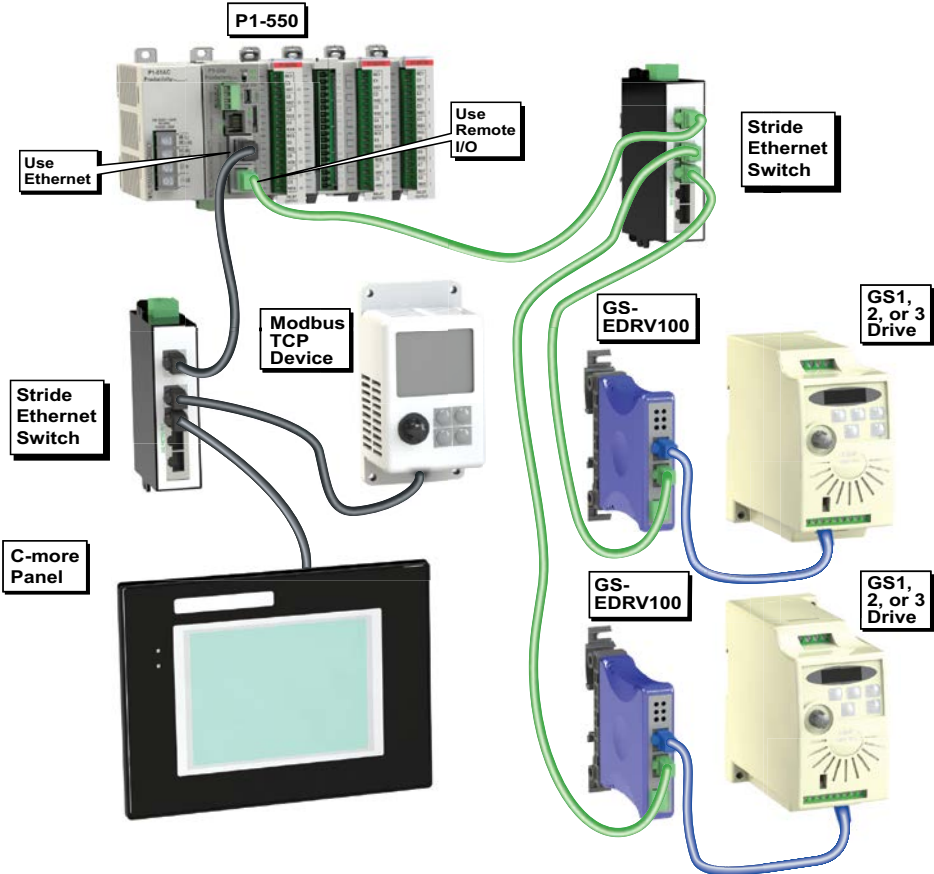

## Communications: Remote I/O and GS-Drives, continued

The GS4-Drive configuration will automatically communicate through the Ethernet card installed in the drive. Some initial UDP broadcast messages occur upon discovery when initiated from the software and at power up. This should be considered if installing the GS4-Drive network with other devices.

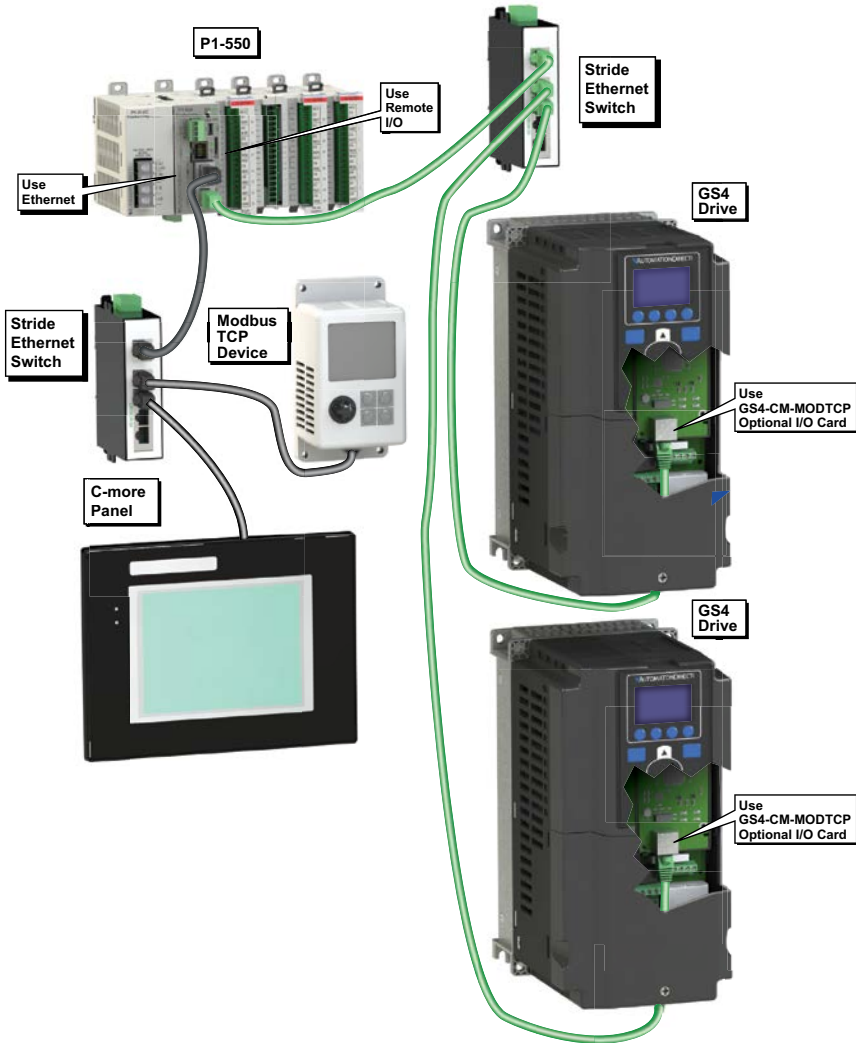

### Configuration of GS-Drive Connections

GS Drive connections are set up with a unique address for each GS drive communications module by the DIP switches on GS-EDRV100 modules, by the rotary switches on the GS4-CM-MODTCP and GS20A-CM-ENETIP modules or by using NetEdit. Since the DIP switch settings can only represent 00-63, setting an address of 64 or greater must be done using NetEdit.

For GS 1, 2 or 3 drives, after the GS-EDRV100 address has been set, be sure to connect the serial cable that comes with the GS-EDRV100 module to the GS-Drive serial port. The GS-EDRV100 will automatically configure the GS-Drive serial port to the correct settings. Once the GS-EDRV100 is properly addressed and connected to the GS-Drive, connect a straight through (patch) Ethernet cable from the Ethernet port of the GS-EDRV100 to an Ethernet switch. Connect a straight through cable from the P1 CPU Local Ethernet Port (Remote I/O) to the same switch.

Open the Productivity Suite Programming software and go online with the P1 CPU. Select Setup and then Hardware Configuration. Select the "Read Configuration" button in the upper left hand corner of this dialog, and the software will discover and display all found GS-Drives.

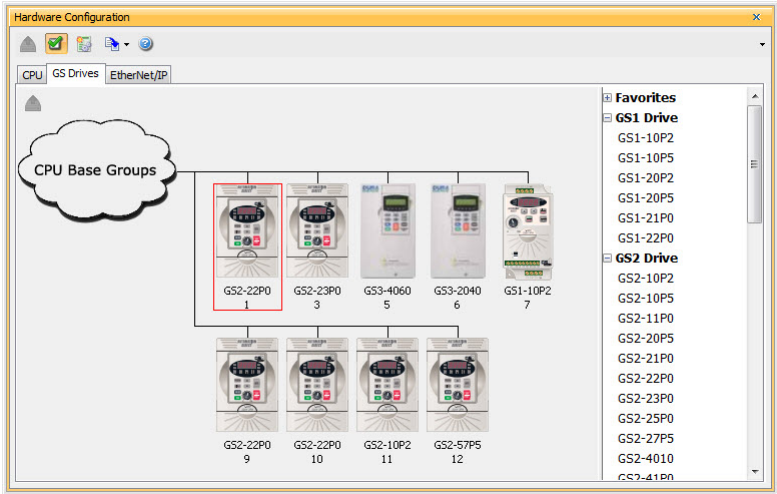
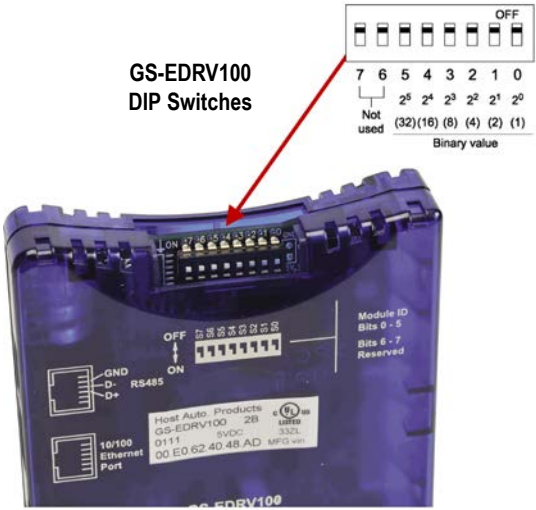

### Configuration of GS-Drive Connections, continued

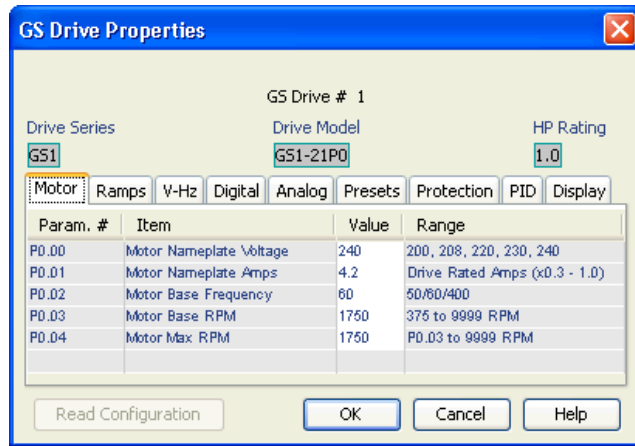

Once the drives have been discovered, the configuration of each drive can be read and written from the programming software.

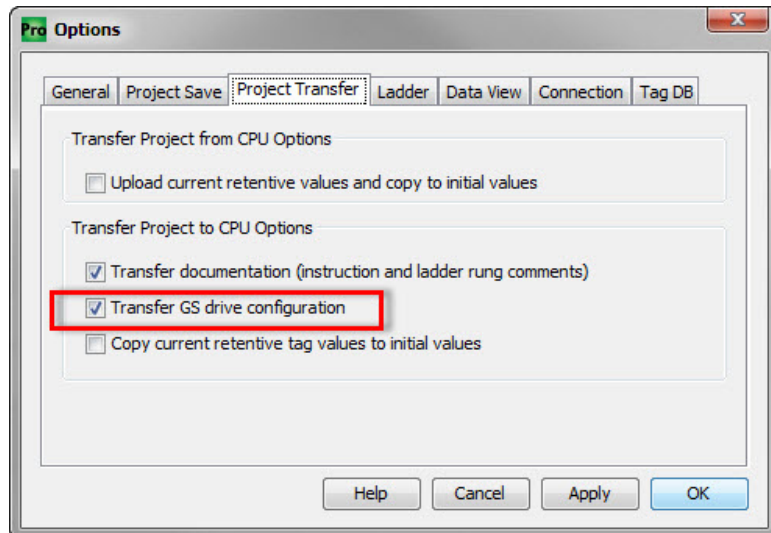

To allow the P1 CPU to automatically write the drive parameters on each CPU project transfer as well as when the CPU is powered up, a setting must be configured in the Productivity project. Go to Tools and Options and select the "Project Transfer" tab. Select the "Transfer GS drive configuration" as shown above. Drive parameters are ONLY transferred to the GS Drive at project transfer or at boot-up of the CPU.

## Configuration of GS-Drive Connections, (continued)

To monitor the status of the connection between the P1 CPU and the GS Drives, there is a Communications Heartbeat function that can be configured for the GS Drives. Use the status bits of the GS Read and GS Write instructions as shown below.

There are two possible communication paths that could be lost:

- P1 CPU to the GS drive communication module
- GS drive communication module to the GS drive

If a Timeout occurs or an error is received, this can be monitored in the ladder code and appropriate action can be taken.

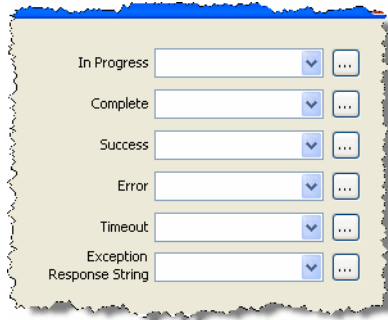

To configure the GS Drives to detect and react to loss of communications, there is a set of parameters that should be configured in the drive. The example below shows the parameters for a GS1, 2, or 3 series drive.

- Parameter P9.03 determines what the drive will do when it detects loss of communications.
- Parameter P9.04 enables the transmission loss detection feature.
- Parameter P9.05 determines the amount of time the drive will wait for a transmission before assuming that the link is lost and react according to how parameter P9.03 is configured.

The GS-EDRV100 reads these configured parameters, and if they are configured for detecting communications loss, it will also monitor for loss of communications on the Ethernet side. If communications are lost on the Ethernet side, the GS-EDRV100 will shut down the GS Drive.

| Communications Parameters |                              |  |         |
|---------------------------|------------------------------|--|---------|
| GS2 Parameter             | Description                  | Range  | Default |
| P9.00                     | Communication Address        | 01 to 254  | 01      |
| P9.01                     | Transmission Speed           | 00: 4800 baud<br>01: 9600 baud<br>02: 19200 baud<br>03: 38400 baud   | 01      |
| P9.02                     | Communication Protocol       | 00: Modbus ASCII mode<br>7 data bits, no parity, 2 stop bits<br>01: Modbus ASCII mode<br>7 data bits, even parity, 1 stop bit<br>02: Modbus ASCII mode<br>7 data bits, odd parity, 1 stop bit<br>03: Modbus RTU mode<br>8 data bits, no parity, 2 stop bits<br>04: Modbus RTU mode<br>8 data bits, even parity, 1 stop bit<br>05: Modbus RTU mode<br>8 data bits, odd parity, 1 stop bit | 00      |
| P9.03                     | Transmission Fault Treatment | 00: Display fault and continue operating<br>01: Display fault and RAMP to stop<br>02: Display fault and COAST to stop<br>03: No fault displayed and continue operating   | 00      |
| P9.04                     | Time Out Detection           | 00: Disable<br>01: Enable  | 00      |
| P9.05                     | Time Out Duration            | 0.1 to 60.0 seconds  | 0.5     |
| ◆ P9.07                   | Parameter Lock               | 00: All parameters can be set and read<br>01: All parameters are read-only   | 00      |

## Configuration of GS-Drive Connections, (continued)

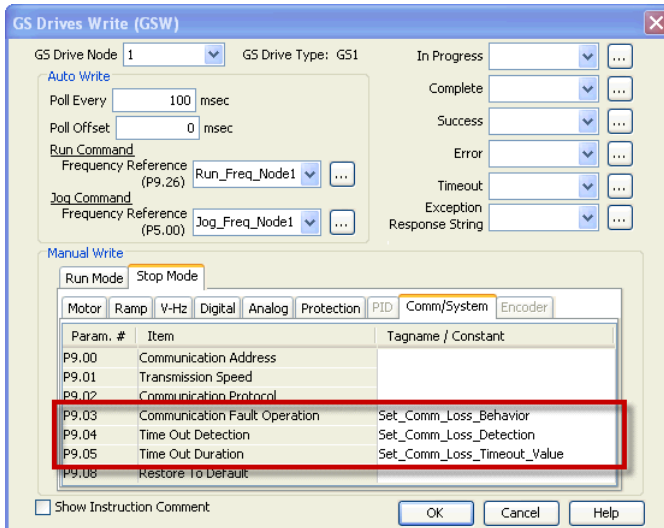

It is very important to note that if the communications loss feature is enabled: either a GS Drive Read or GS Drive Write instruction needs to be configured to communicate to the GS-EDRV100 and GS Drive at a poll rate that will prevent the GS-EDRV100 and GS Drive from detecting a loss of communication.

There is also a parameter (P22.01) that can be monitored to check the health of the serial connection between the GS-EDRV100 and the GS Drive. This parameter can be monitored in the ladder code and appropriate action taken if serial communications loss is detected.

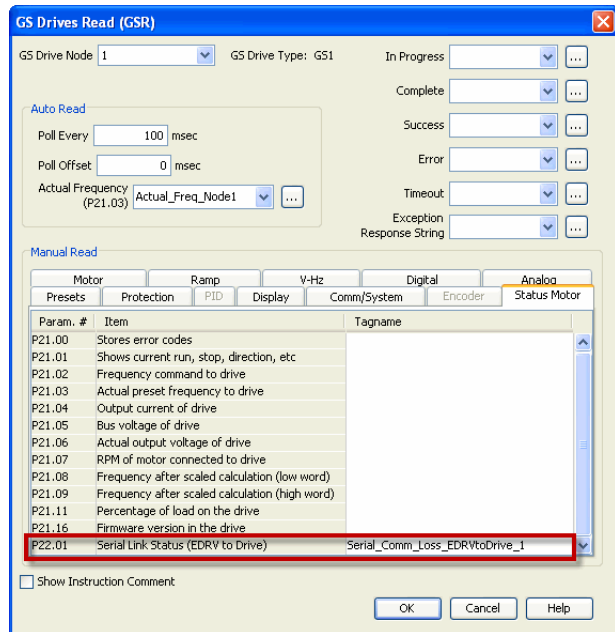

# Communications: Port Configuration

The Communications Port Configuration for any module containing comm ports is accessed from the Hardware Configuration window. For example, to access the P1-540/550 communications port configuration, first select the CPU from the Hardware Configuration window by double left-clicking or by right-clicking the CPU and selecting Open from the drop down menu. This will display the P1-540/550 configuration window seen here.

The following descriptions will focus on the P1-540/550 communications ports.

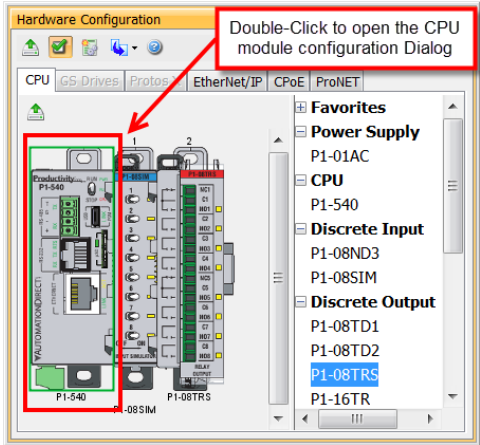

### Ethernet Configuration

Ethernet Ports: The 10/100Base-T Ethernet port on the P1-540/550 CPU.

Ethernet: The Ethernet port can connect to Modbus TCP Client devices, Modbus TCP Server devices and PCs running the Productivity1000 programming software. The Ethernet Port is configured with an IP Address, Subnet Mask and Default Gateway, allowing it to function seamlessly on a typical LAN network.

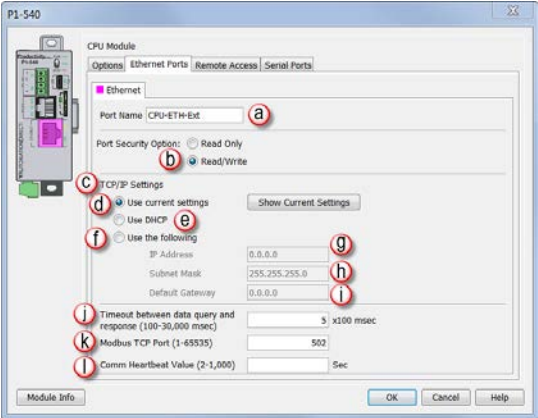

### External Ethernet Port Settings



**NOTE:** Two CPU Remote I/O networks cannot co-exist on the same LAN.

- (a) Port Name: Allows the entry of a unique Name for the Ethernet Port. This Name is referenced in the Communications instructions (MRX, MWX, RX, WX) to select the Port to send the request from.
- (b) Port Security Option: This Option can be used as a simple Security measure to prevent Modbus TCP write requests from being accepted by the CPU. To allow Reads and Writes, select Read/Write.
- (c) TCP/IP Settings: The IP Setting of this Port may be changed in several ways:
  - a. The settings may be entered manually in the Choose CPU tool in the Productivity Suite programming software. This allows the user to make changes to the IP to allow connection by the computer running the Productivity Suite programming software. Changes are sent using Multicast Messages.
  - b. The TCP/IP Settings can be saved as part of the project. This must be Enabled in the P1-540 Hardware Configuration Settings by selecting Use the Following (Item f below). If handled this way, the Settings stored in the project will take effect at Project Transfer and at boot up only. The Settings may be changed after boot up.
- (d) Use Current Settings: When selected, Project Transfer or boot up will not make changes to the TCP/IP Settings of the CPU.
- (e) Use DHCP: This specifies that the CPU should request its IP Settings from a DHCP Server on the network.



**NOTE:** If the CPU is set to use DHCP for its IP Settings it cannot, in all likelihood, be used as a Modbus TCP Server.

- (f) Use The Following: If this Option is selected, the CPU will set itself to the specified project Settings upon Project Transfer or at boot up.
- (g) IP Address: This field is where the IP Address is specified in Four Octets.  
For Example: 192.168.1.5
- (h) Subnet Mask: This field is where the Subnet Mask is specified in Four Octets (i.e., 255.255.255.0). The Subnet Mask is used in conjunction with the IP Address to configure a Logical Network.
- (i) Default Gateway: This field is where the Default Gateway Address is specified in Four Octets (i.e., 192.168.1.1). This is typically the IP Address of the router on the network. If a target IP Address is specified in an outgoing message from the CPU that is not in the Local Subnet, the Default Gateway Address is where this message will be sent.
- (j) Timeout Between Data Query and Response: The Time period specified in this field is the Time between the queries sent from the CPU (via a Communication instruction, such as a MRX, MWX, RX or WX) and the Time a response from that device is received. If the Response takes longer to receive or is not received within the specified Time period, a Timeout Error will occur for the given instruction. Each instruction has a Timeout Status bit that can be assigned to it.

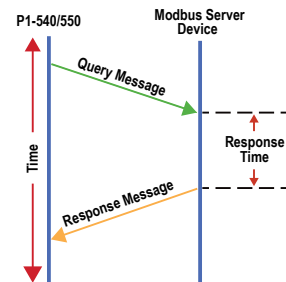

- (k) **Modbus TCP Port:** This is the listening TCP Port Number for Modbus TCP connections. If necessary, this value can be adjusted for advanced router access. In most situations, this Port Number should be left at 502.
- (l) **Comm Heartbeat Value:** This feature allows the ladder logic in the CPU to know if a device has stopped communicating to the CPU. If a value is placed in this field, the CPU will start a timer between each communication packet coming in to the CPU. If a communication packet fails to be received by the CPU within the specified time period, the System Bit Ethernet Heartbeat Timeout Bit will become true.

### Local Ethernet Port Settings

- (m) **Timeout Between Data Query and Response:** The Time period specified in this field is the Time between the queries sent from the CPU (for Remote I/O Nodes and GS Drive Nodes) and the Time a Response from that device is Received. If the Response takes longer to receive (or is not received) than the specified Time period, a Timeout Error will occur for the given device and an Error will be generated in the Error Log. See Modbus Server diagram shown on previous page.
- (n) **Comm Heartbeat Value:** This value specifies how long the Remote I/O Slaves should wait for a communication packet from the CPU. If a communication packet is not received from the CPU within the specified time period, all outputs on the Remote Slave will be turned OFF.

### Remote Access Configuration

- (a) **Web Server Function:** Provides the ability to make a non secure web connection to the P1-540/550 in order to access the USB pen drive and view read-only system tags. When enabled, a port number selection is required.
  - ◇ Port: (Default 80) Allows user to set a port number ranging from 1-65535.

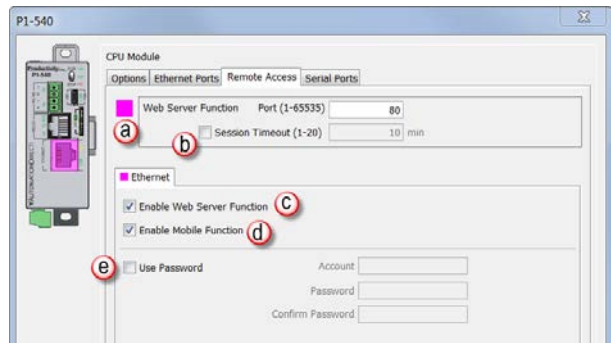

- (b) **Session Timeout:** Allows the user to set a specific time limit (1–20 min.) on inactivity that will close the Web Server connection. If there is no activity between the PC and the Web Server for the specified time limit, the connection will close.
- (c) **Enable Web Server Function:** Select this box to enable/disable Web Server Function > See bullet above.
- (d) **Mobile Function:** Enables Remote Access which allows the CPU Data Remote Monitor App to monitor the selected tags.
- (e) **Password Option:** Allows the user to set a password for access to the Web Server.
  - ◇ Enter an account name and password of up to a combination of 16 numbers and characters (can include special characters).

### Serial Configuration

When the Serial Ports Tab is selected, the Serial Ports settings are displayed as shown below.

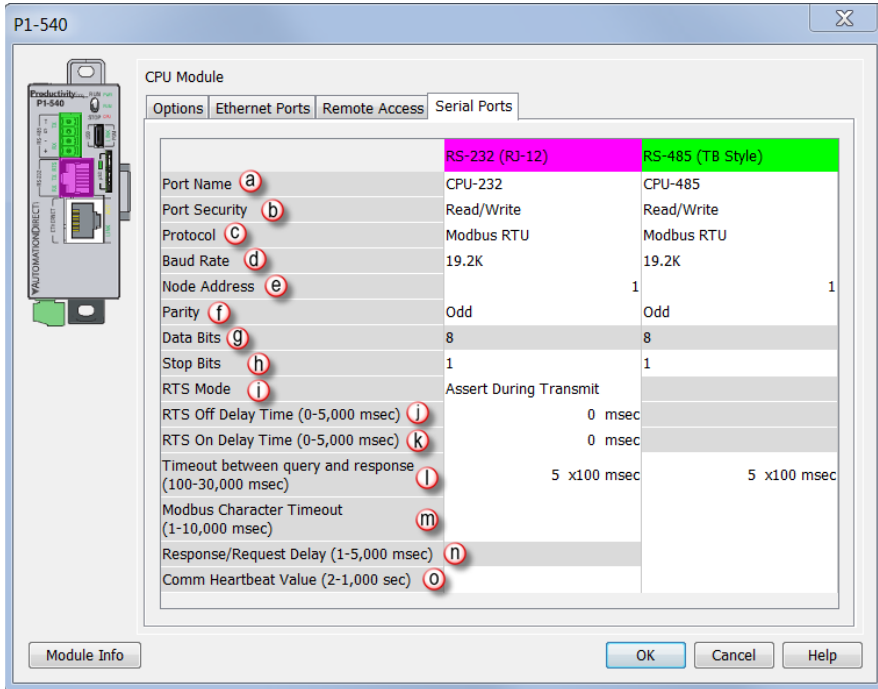

There are two Serial Ports on the P1-540 and P1-550 CPUs; an RS-232 Port with an RJ-12 connector and a 2-wire RS-485 Port with a removable three point terminal block. Both Ports are capable of Modbus RTU Client (device that initiates communications requests) and Server (device that responds to communications requests) communications. They are also capable of ASCII outgoing strings and incoming strings.

### RS-232 and RS-485 Port Settings

- (a) Port Name: Allows the entry of a unique name for the RS-232 and RS-485 Ports. This name is referenced inside of the Communications instructions (MRX, MWX, RX, WX) and ASCII instructions (AIN, AOUT, CPO, CPI) to select the Port to send or receive the request.
- (b) Port Security: This Option can be used as a simple Security measure to prevent Modbus TCP write requests from being accepted by the CPU. To allow Reads and Writes, select Read/Write.
- (c) Protocol: This field determines whether the Port is used for Modbus RTU communications, sending or receiving ASCII Strings or performing the Custom Protocol function.
- (d) Baud Rate: Choose the Baud Rate that your device and the CPU should communicate in this field. The appropriate choice will vary greatly with device, application and environment. The important point is that all devices communicating on the network need to be set to the same Baud Rate. The available Baud Rates are 1200, 2400, 9600, 19200, 33600, 38400, 57600 and 115200 bps.

## RS-232 and RS-485 Port Settings, continued

- e) **Node Address:** This field is used only when the CPU is a Modbus RTU Server device. This field is used to uniquely identify the CPU on the network. This setting is also sometimes referred to as a Station Address. This field can be set from 1 to 247.
- f) **Parity:** The Parity Bit is used as a simple, low-level form of Error Detection. All devices on the network need to be at the same Parity setting. The appropriate choice will vary with devices. Valid selections are None, Even and Odd.
- g) **Data Bits:** This field determines whether the communications packet uses Seven Data Bits or Eight Data Bits. Eight Data Bits is the only valid selection for Modbus RTU. Either Seven or Eight Data Bits can be selected when using ASCII communications. Set this field to match the device that is connected to the CPU.
- h) **Stop Bits:** This field determines whether the communications packet uses One or Two Stop Bits. Set this field to match the device that is connected to the CPU.
- i) **RTS Mode:** This field allows selection of whether or not RTS is asserted during data transmission. Used for hardware handshaking in the standard way. You may need to manually configure RTS. Refer to your instrument documentation to determine its specific behavior.
- j) **RTS Off Delay Time (RS-232 Only):** This Time period is the amount of Time between the end of the data transmission to when the RTS signal is turned off. The diagram below (left) illustrates this. This setting may be needed when using media converters (RS-232 to RS-422/485 converters) and/or radio modems. A delay may be needed at the end of the data transmission for processing time in the devices.

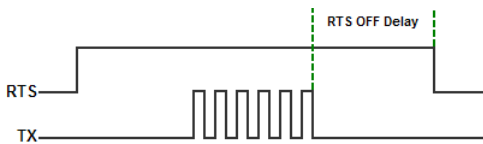

j. RTS Off Delay

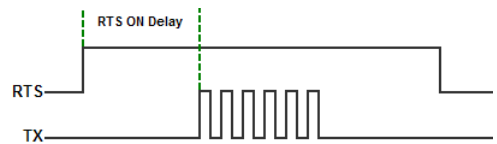

k. RTS On Delay

- k) **RTS On Delay Time (RS-232 Only):** This Time period is the amount of Time between when the RTS Signal is turned ON and the data transmission begins. The diagram above (right) illustrates this. This setting may be needed when using media converters (RS-232 to RS-485 converters) and/or radio modems. A delay may be needed after the assertion of the RTS Signal and when the data transmission begins for processing time in the device.
- l) **Timeout Between Query and Response:** The Time period specified in this field is the Time between the queries sent from the CPU (via a Communication instruction, such as an MRX, MWX, RX, or WX) and the Time a Response from that device is Received. If the Response takes longer to receive (or is not received) than the specified Time period, a Timeout Error will occur for the given instruction. Each instruction has a Timeout Status bit that can be assigned to it.

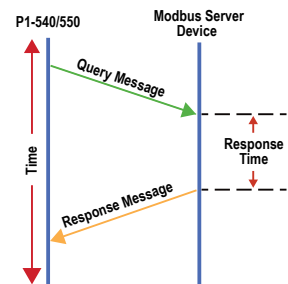

## RS-232 and RS-485 Port Settings, continued

**(m)** Modbus Character Timeout: The Modbus Character Delay Time is specified as the Time between two bytes (or characters) within a given Modbus Message. The Modbus RTU specification states that this time must be no more than 1.5 Character Times (real time based on Baud Rate). Sometimes delays do occur between bytes when using radio modems, media converters, etc. This setting allows some tolerance in these situations for the incoming Modbus Messages in the CPU. The CPU will wait for the amount of time specified in this field before discarding the incomplete packet. If the CPU does not receive the remainder of the Message within the specified Time Frame, it will discard the first portion of the Message and wait for a new Message.

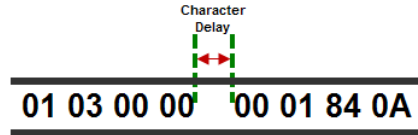

**(n)** Response/Request Delay (RS-485 Only): This setting is used when the CPU is a Modbus RTU Server or Client on the RS-485 Port.

The total Response Time can be up to the Total CPU Scan Time + the Value specified in this field. When using 2-wire RS-485 communications, sometimes Echoes can occur since both devices use the same differential signal pair to send and receive.

- If acting as a Server (on left below), upon receiving a Modbus Request, the CPU will wait for the time period specified in this field before sending a Response. This can be used with slow clients that need extra time to change from sending to receiving.
- If acting as a Client (on right below), after receiving a Modbus Response, the CPU will wait for the time period specified in this field before sending another Request. This can be used to delay request messages in order to give extra time for slow server devices.

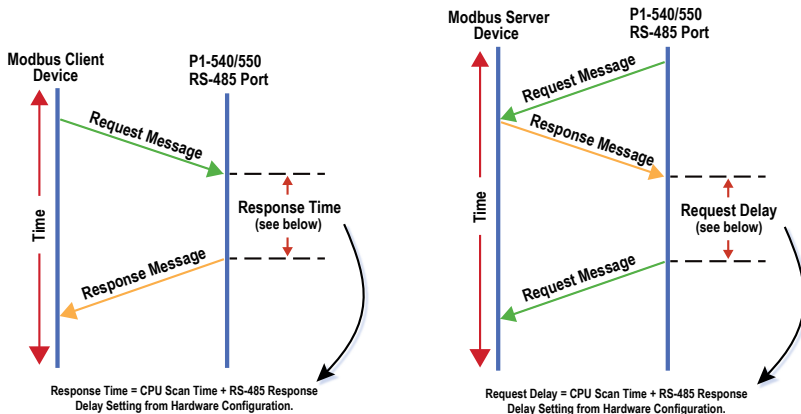

**(o)** Comm Heartbeat Value: This feature allows the ladder logic in the CPU to know if a device has stopped communicating to the CPU. If a value is placed in this field, the CPU will start a timer between each communication packet coming in to the CPU. If a communication packet fails to be received by the CPU within the specified Time period, the System Bit RS-232 Heartbeat Timeout Bit or RS-485 Heartbeat Timeout Bit will become true.

# Communications: Error Codes



**NOTE:** The only time you will see Communications Error Codes is when the CPU is the Master of a Communications Network.

To simplify the process of identifying a possible Error, the Productivity®1000 CPU will automatically report to a specific memory location an Error Code that helps identify the existing issue. The Error Codes are reported in the Exception Response String Tag specified in the instruction as shown below.

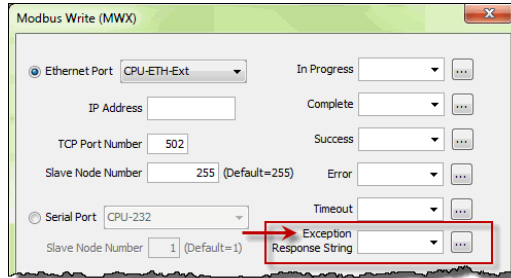

The Exception Response String field is available on the following instructions:

The Table shown below provides a list of Productivity1000 Communication Error Codes that may be reported by the Productivity CPU.

- GS Drives Read
- GS Drives Write
- Modbus Read
- Modbus Write
- Network Read
- Network Write
- Dataworx Request

| Productivity1000 Communication Error Codes |  |   |
|--|--|---|
| Error Code                                 | Description  | Suggested Fix   |
| 01   | Function Code not supported.   | Check instruction or connected device and correct Function code or address range selected.  |
| 02   | Address out of range. This error is typically generated when a Modbus address has been requested that does not exist in the CPU. | Check instruction or connected device and correct Function code or address range selected.  |
| 03   | Illegal Data Value. This error is typically generated when the Modbus request sent to the CPU is formed incorrectly.             | Check the Modbus request against the Modbus protocol specification ( <a href="http://www.modbus.org">www.modbus.org</a> ) to verify that it was formed correctly. |
| 04   | Device Failure.  | Check connected device.   |
| 06   | Slave Device is Busy. This error is typically due to excess communications to the EDRV.  | Slow down the poll rate in the GS instruction.  |

# P1000 EtherNet/IP Error Codes











--- CPU server currently supported errors



--- CPU server (will not generate error)

Note: Other adapters may generate this error









| P1000 EtherNet/IP Error Codes |                       |   |  |                 |
|-------------------------------|-----------------------|---|--|-----------------|
| General Status Error          | Extended Status Error | Name  | Description  | P1000 Supported |
| 0x01                          | 0x0100                | Connection In Use/<br>Duplicate Forward Open          | A connection is already established from the target device sending a Forward Open request or the target device has sent multiple forward open request. This could be caused by poor network traffic. Check the cabling, switches and connections.  |                 |
| 0x01                          | 0x0103                | Transport Class/<br>Trigger Combination not supported | The Transport class and trigger combination is not supported. The Productivity1000 CPU only supports Class 1 and Class 3 transports and triggers: Change of State and Cyclic.  |                 |
| 0x01                          | 0x0106                | Owner Conflict  | An existing exclusive owner has already configured a connection to this Connection Point. Check to see if other Scanner devices are connected to this adapter or verify that Multicast is supported by adapter device if Multicast is selected for Forward Open. This could be caused by poor network traffic. Check the cabling, switches and connections.                        |                 |
| 0x01                          | 0x0107                | Target Connection Not Found                           | This occurs if a device sends a Forward Close on a connection and the device can't find this connection. This could occur if one of these devices has powered down or if the connection timed out on a bad connection. This could be caused by poor network traffic. Check the cabling, switches and connections.  |                 |
| 0x01                          | 0x0108                | Invalid Network Connection Parameter                  | This error occurs when one of the parameters specified in the Forward Open message is not supported such as Connection Point, Connection type, Connection priority, redundant owner or exclusive owner. The Productivity1000 CPU does not return this error and will instead use errors 0x0120, 0x0121, 0x0122, 0x0123, 0x0124, 0x0125 or 0x0132 instead.                          |                 |
| 0x01                          | 0x0109                | Invalid Connection Size                               | This error occurs when the target device doesn't support the requested connection size. Check the documentation of the manufacturer's device to verify the correct Connection size required by the device. Note that most devices specify this value in terms of bytes. The Productivity1000 CPU does not return this error and will instead use errors 0x0126, 0x0127 and 0x0128. |                 |
| 0x01                          | 0x0110                | Target for Connection Not Configured                  | This error occurs when a message is received with a connection number that does not exist in the target device. This could occur if the target device has powered down or if the connection timed out. This could be caused by poor network traffic. Check the cabling, switches and connections.  |                 |
| 0x01                          | 0x0111                | RPI Not Supported                                     | This error occurs if the Originator is specifying an RPI that is not supported. The Productivity1000 CPU will accept a minimum value of 10ms on a CIP Forward Open request. However, the CPU will produce at the specified rate up to the scan time of the installed project. The CPU cannot product any faster than the scan time of the running project.                         |                 |

| P1000 EtherNet/IP Error Codes |                       |  |  |   |
|-------------------------------|-----------------------|--|--|---|
| General Status Error          | Extended Status Error | Name   | Description  | P1000 Supported   |
| 0x01                          | 0x0112                | RPI Value not acceptable                               | <p>This error can be returned if the Originator is specifying an RPI value that is not acceptable. There may be six additional values following the extended error code with the acceptable values. An array can be defined for this field in order to view the extended error code attributes. If the Target device supports extended status, the format of the values will be as shown below:</p> <ul style="list-style-type: none"> <li>• Unsigned Integer 16, Value = 0x0112, Explanation: Extended Status code</li> <li>•  Unsigned Integer 8, Value = variable, Explanation: Acceptable Originator to Target RPI type, values: 0 = The RPI specified in the forward open was acceptable (O -&gt; T value is ignored), 1 = unspecified (use a different RPI), 2 = minimum acceptable RPI (too fast), 3 = maximum acceptable RPI (too slow), 4 = required RPI to corrected mismatch (data is already being consumed at a different RPI), 5 to 255 = reserved.</li> <li>• Unsigned Integer 32, Value = variable, Explanation: Value of O -&gt; T RPI that is within the acceptable range for the application.</li> <li>• Unsigned Integer 32, Value = variable, Explanation: Value of T -&gt; O RPI that is within the acceptable range for the application.</li> </ul> |    |
| 0x01                          | 0x0113                | Out of Connections                                     | The Productivity1000 EtherNet/IP Adapter connection limit of 4 when doing Class 3 connections has been reached. An existing connection must be dropped in order for a new one to be generated.   |    |
| 0x01                          | 0x0114                | Vendor ID or Product Code Mismatch                     | The compatibility bit was set in the Forward Open message but the Vendor ID or Product Code did not match.   |    |
| 0x01                          | 0x0115                | Device Type Mismatch                                   | The compatibility bit was set in the Forward Open message but the Device Type did not match.   |    |
| 0x01                          | 0x0116                | Revision Mismatch                                      | The compatibility bit was set in the Forward Open message but the major and minor revision numbers were not a valid revision.  |  |
| 0x01                          | 0x0117                | Invalid Produced or Consumed Application Path          | This error is returned from the Target device when the Connection Point parameters specified for the O -> T (Output) or T -> O (Input) connection is incorrect or not supported. The Productivity1000 CPU does not return this error and uses the following error codes instead: 0x012A, 0x012B or 0x012F.   |  |
| 0x01                          | 0x0118                | Invalid or Inconsistent Configuration Application Path | This error is returned from the Target device when the Connection Point parameter specified for the Configuration data is incorrect or not supported. The Productivity1000 CPU does not return this error and uses the following error codes instead: 0x0129 or 0x012F.  |  |
| 0x01                          | 0x0119                | Non-listen Only Connection Not Opened                  | This error code is returned when an Originator device attempts to establish a listen only connection and there is no non-listen only connection established. The Productivity1000 CPU does not support listen only connections as Scanner or Adapter.  |  |





## Chapter 6: Communications

### P1000 EtherNet/IP Error Codes

| General Status Error | Extended Status Error | Name   | Description   | P1000 Supported   |
|----------------------|-----------------------|--|---|---|
| 0x01                 | 0x011A                | Target Object Out of Connections                                     | The maximum number of connections supported by this instance of the object has been exceeded.   |    |
| 0x01                 | 0x011B                | RPI is smaller than the Production Inhibit Time                      | The Target to Originator RPI is smaller than the Target to Originator Production Inhibit Time. Consult the manufacturer's documentation as to the minimum rate that data can be produced and adjust the RPI to greater than this value.   |    |
| 0x01                 | 0x011C                | Transport Class Not Supported  | The Transport Class requested in the Forward Open is not supported. Only Class 1 and Class 3 classes are supported in the Productivity1000 CPU.   |    |
| 0x01                 | 0x011D                | Production Trigger Not Supported                                     | The Production Trigger requested in the Forward Open is not supported. In Class 1, only Cyclic and Change of state are supported in the Productivity1000 CPU. In Class 3, Application object is supported.  |    |
| 0x01                 | 0x011E                | Direction Not Supported  | The Direction requested in the Forward Open is not supported.   |    |
| 0x01                 | 0x011F                | Invalid Originator to Target Network Connection Fixed/ Variable Flag | The Originator to Target fixed/variable flag specified in the Forward Open is not supported. Only Fixed is supported in the Productivity1000 CPU.   |    |
| 0x01                 | 0x0120                | Invalid Target to Originator Network Connection Fixed/ Variable Flag | The Target to Originator fixed/variable flag specified in the Forward Open is not supported. Only Fixed is supported in the Productivity1000 CPU.   |    |
| 0x01                 | 0x0121                | Invalid Originator to Target Network Connection Priority             | The Originator to Target Network Connection Priority specified in the Forward Open is not supported. Low, High, Scheduled and Urgent are supported in the Productivity1000 CPU.   |    |
| 0x01                 | 0x0122                | Invalid Target to Originator Network Connection Priority             | The Target to Originator Network Connection Priority specified in the Forward Open is not supported. Low, High, Scheduled and Urgent are supported in the Productivity1000 CPU.   |    |
| 0x01                 | 0x0123                | Invalid Originator to Target Network Connection Type                 | The Originator to Target Network Connection Type specified in the Forward Open is not supported. Only Unicast is supported for O -> T (Output) data in the Productivity1000 CPU.  |  |
| 0x01                 | 0x0124                | Invalid Target to Originator Network Connection Type                 | The Target to Originator Network Connection Type specified in the Forward Open is not supported. Multicast and Unicast is supported in the Productivity1000 CPU. Some devices may not support one or the other so if this error is encountered try the other method.  |  |
| 0x01                 | 0x0125                | Invalid Originator to Target Network Connection Redundant_Owner      | The Originator to Target Network Connection Redundant_Owner flag specified in the Forward Open is not supported. Only Exclusive owner connections are supported in the Productivity1000 CPU.  |  |
| 0x01                 | 0x0126                | Invalid Configuration Size   | This error is returned when the Configuration data sent in the Forward Open does not match the size specified or is not supported by the Adapter. The Target device may return an additional Unsigned Integer 16 value that specifies the maximum size allowed for this data. An array can be defined for this field in order to view the extended error code attributes. |  |

| P1000 EtherNet/IP Error Codes |                       |   |   |   |
|-------------------------------|-----------------------|---|---|---|
| General Status Error          | Extended Status Error | Name                                      | Description   | P1000 Supported   |
| 0x01                          | 0x0127                | Invalid Originator to Target Size         | <p>This error is returned when the Originator to Target (Output data) size specified in the Forward Open does not match what is in the Target. Consult the documentation of the Adapter device to verify the required size. Note that if the Run/Idle header is requested, it will add 4 additional bytes and must be accounted for in the Forward Open calculation. The Productivity1000 CPU always requires the Run/Idle header so if the option doesn't exist in the Scanner device, you must add an additional 4 bytes to the O -&gt; T (Output) setup. Some devices may publish the size that they are looking for as an additional attribute (Unsigned Integer 16 value) of the Extended Error Code. An array can be defined for this field in order to view the extended error code attributes.</p> <p>Note: This error may also be generated when a Connection Point value that is invalid for IO Messaging (but valid for other cases such as Explicit Messaging) is specified, such as 0. Please verify if the Connection Point value is valid for IO Messaging in the target device.</p> |    |
| 0x01                          | 0x0128                | Invalid Target to Originator Size         | <p>This error is returned when the Target to Originator (Input data) size specified in the Forward Open does not match what is in Target. Consult the documentation of the Adapter device to verify the required size. Note that if the Run/Idle header is requested, it will add 4 additional bytes and must be accounted for in the Forward Open calculation. The Productivity1000 CPU does not support a Run/Idle header for the T -&gt; O (Input) data. Some devices may publish the size that they are looking for as an additional attribute (Unsigned Integer 16 value) of the Extended Error Code. An array can be defined for this field in order to view the extended error code attributes.</p> <p>Note: This error may also be generated when a Connection Point value that is invalid for IO Messaging (but valid for other cases such as Explicit Messaging) is specified, such as 0. Please verify if the Connection Point value is valid for IO Messaging in the target device.</p>   |    |
| 0x01                          | 0x0129                | Invalid Configuration Application Path    | <p>This error will be returned by the Productivity1000 CPU if a Configuration Connection with a size other than 0 is sent to the CPU. The Configuration Connection size must always be zero if it this path is present in the Forward Open message coming from the Scanner device.</p>  |   |
| 0x01                          | 0x012A                | Invalid Consuming Application Path        | <p>This error will be returned by the Productivity1000 CPU if the Consuming (O -&gt; T) Application Path is not present in the Forward Open message coming from the Scanner device or if the specified Connection Point is incorrect.</p>   |  |
| 0x01                          | 0x012B                | Invalid Producing Application Path        | <p>This error will be returned by the Productivity1000 CPU if the Producing (T -&gt; O) Application Path is not present in the Forward Open message coming from the Scanner device or if the specified Connection Point is incorrect.</p>   |  |
| 0x01                          | 0x012C                | Config. Symbol Does not Exist             | <p>The Originator attempted to connect to a configuration tag name that is not supported in the Target.</p>   |  |
| 0x01                          | 0x012D                | Consuming Symbol Does not Exist           | <p>The Originator attempted to connect to a consuming tag name that is not supported in the Target.</p>   |  |
| 0x01                          | 0x012E                | Producing Symbol Does not Exist           | <p>The Originator attempted to connect to a producing tag name that is not supported in the Target.</p>   |  |
| 0x01                          | 0x012F                | Inconsistent Application Path Combination | <p>The combination of Configuration, Consuming and Producing application paths specified are inconsistent.</p>  |  |

## Chapter 6: Communications

| P1000 EtherNet/IP Error Codes |                       |  |   |   |
|-------------------------------|-----------------------|--|---|---|
| General Status Error          | Extended Status Error | Name   | Description   | P1000 Supported   |
| 0x01                          | 0x0130                | Inconsistent Consume data format               | Information in the data segment not consistent with the format of the data in the consumed data.  |    |
| 0x01                          | 0x0131                | Inconsistent Product data format               | Information in the data segment not consistent with the format of the data in the produced data.  |    |
| 0x01                          | 0x0132                | Null Forward Open function not supported       | The target device does not support the function requested in the NULL Forward Open request. The request could be such items as "Ping device", "Configure device application", etc.  |    |
| 0x01                          | 0x0133                | Connection Timeout Multiplier not acceptable   | The Connection Multiplier specified in the Forward Open request not acceptable by the Target device (once multiplied in conjunction with the specified timeout value). Consult the manufacturer device's documentation on what the acceptable timeout and multiplier are for this device.             |    |
| 0x01                          | 0x0203                | Connection Timed Out                           | This error will be returned by the Productivity1000 CPU if a message is sent to the CPU on a connection that has already timed out. Connections time out if no message is sent to the CPU in the time period specified by the RPI rate X Connection multiplier specified in the Forward Open message. |    |
| 0x01                          | 0x0204                | Unconnected Request Timed Out                  | This time out occurs when the device sends an Unconnected Request and no response is received within the specified time out period. In the Productivity1000 CPU, this value may be found in the hardware configuration under the Ethernet port settings for the P1-540/550.                           |    |
| 0x01                          | 0x0205                | Parameter Error in Unconnected Request Service | This error occurs when Connection Tick Time/Connection time-out combination is specified in the Forward Open or Forward Close message this is not supported by the device.  |    |
| 0x01                          | 0x0206                | Message Too Large for Unconnected Send Service | Occurs when Unconnected_Send message is too large to be sent to the network.  |   |
| 0x01                          | 0x0207                | Unconnected Acknowledge without Reply          | This error occurs if an Acknowledge was received but no data response occurred. Verify that the message that was sent is supported by the Target device using the device manufacturer's documentation.  |  |
| 0x01                          | 0x0301                | No Buffer Memory Available                     | This error occurs if the Connection memory buffer in the target device is full. Correct this by reducing the frequency of the messages being sent to the device and/or reducing the number of connections to the device. Consult the manufacturer's documentation for other means of correcting this. |  |
| 0x01                          | 0x0302                | Network Bandwidth not Available for Data       | This error occurs if the Producer device cannot support the specified RPI rate when the connection has been configured with schedule priority. Reduce the RPI rate or consult the manufacturer's documentation for other means to correct this.   |  |
| 0x01                          | 0x0303                | No Consumed Connection ID Filter Available     | This error occurs if a Consumer device doesn't have an available consumed_connection_id filter.   |  |
| 0x01                          | 0x0304                | Not Configured to Send Scheduled Priority Data | This error occurs if a device has been configured for a scheduled priority message and it cannot send the data at the scheduled time slot.  |  |

| P1000 EtherNet/IP Error Codes |                       |  |  |                 |
|-------------------------------|-----------------------|--|--|-----------------|
| General Status Error          | Extended Status Error | Name   | Description  | P1000 Supported |
| 0x01                          | 0x0305                | Schedule Signature Mismatch  | This error occurs if the schedule priority information does not match between the Target and the Originator.   |                 |
| 0x01                          | 0x0306                | Schedule Signature Validation not Possible                                 | This error occurs when the schedule priority information sent to the device is not validated.  |                 |
| 0x01                          | 0x0311                | Port Not Available   | This error occurs when a port number specified in a port segment is not available. Consult the documentation of the device to verify the correct port number.  |                 |
| 0x01                          | 0x0312                | Link Address Not Valid   | The Link address specified in the port segment is not correct. Consult the documentation of the device to verify the correct port number.  |                 |
| 0x01                          | 0x0315                | Invalid Segment in Connection Path   | This error occurs when the target device cannot understand the segment type or segment value in the Connection Path. Consult the documentation of the device to verify the correct segment type and value. If a Connection Point greater than 255 is specified this error could occur. |                 |
| 0x01                          | 0x0316                | Forward Close Service Connection Path Mismatch                             | This error occurs when the Connection path in the Forward Close message does not match the Connection Path configured in the connection. Contact Tech Support if this error persists.  |                 |
| 0x01                          | 0x0317                | Scheduling Not Specified   | This error can occur if the Schedule network segment or value is invalid.  |                 |
| 0x01                          | 0x0318                | Link Address to Self Invalid   | If the Link address points back to the originator device, this error will occur.   |                 |
| 0x01                          | 0x0319                | Secondary Resource Unavailable   | This occurs in a redundant system when the secondary connection request is unable to duplicate the primary connection request.   |                 |
| 0x01                          | 0x031A                | Rack Connection Already established  | The connection to a module is refused because part or all of the data requested is already part of an existing rack connection.  |                 |
| 0x01                          | 0x031B                | Module Connection Already established                                      | The connection to a rack is refused because part or all of the data requested is already part of an existing module connection.  |                 |
| 0x01                          | 0x031C                | Miscellaneous  | This error is returned when there is no other applicable code for the error condition. Consult the manufacturer's documentation or contact Tech support if this error persist.   |                 |
| 0x01                          | 0x031D                | Redundant Connection Mismatch  | This error occurs when these parameters don't match when establishing a redundant owner connection: O -> T RPI, O -> T Connection Parameters, T -> O RPI, T -> O Connection Parameters and Transport Type and Trigger.   |                 |
| 0x01                          | 0x031E                | No more User Configurable Link Resources Available in the Producing Module | This error is returned from the Target device when no more available Consumer connections available for a Producer.  |                 |

## Chapter 6: Communications

| P1000 EtherNet/IP Error Codes |                       |   |   |   |
|-------------------------------|-----------------------|---|---|---|
| General Status Error          | Extended Status Error | Name  | Description   | P1000 Supported   |
| 0x01                          | 0x031F                | No User Configurable Link Consumer Resources Configured in the Producing Module | This error is returned from the Target device when no Consumer connections have been configured for a Producer connection.  |    |
| 0x01                          | 0x0800                | Network Link Offline  | The Link path is invalid or not available.  |    |
| 0x01                          | 0x0810                | No Target Application Data Available  | This error is returned from the Target device when the application has no valid data to produce.  |    |
| 0x01                          | 0x0811                | No Originator Application Data Available  | This error is returned from the Originator device when the application has no valid data to produce.  |    |
| 0x01                          | 0x0812                | Node Address has changed since the Network was scheduled                        | This specifies that the router has changed node addresses since the value configured in the original connection.  |    |
| 0x01                          | 0x0813                | Not Configured for Off-subnet Multicast   | The producer has been requested to support a Multicast connection for a consumer on a different subnet and does not support this functionality.   |    |
| 0x01                          | 0x0814                | Invalid Produce/ Consume Data format  | Information in the data segment not consistent with the format of the data in the consumed or produced data. Errors 0x0130 and 0x0131 are typically used for this situation in most devices now.                      |    |
| 0x02                          | N/A                   | Resource Unavailable for Unconnected Send                                       | The Target device does not have the resources to process the Unconnected Send request.  |    |
| 0x04                          | N/A                   | Path Segment Error in Unconnected Send  | The Class, Instance or Attribute value specified in the Unconnected Explicit Message request is incorrect or not supported in the Target device. Check the manufacturer's documentation for the correct codes to use. |    |
| 0x09                          | Index to error        | Error in Data Segment   | This error code is returned when an error is encountered in the Data segment portion of a Forward Open message. The Extended Status value is the offset in the Data segment where the error was encountered.          |  |
| 0x0C                          | Optional              | Object State Error  | This error is returned from the Target device when the current state of the Object requested does not allow it to be returned. The current state can be specified in the Optional Extended Error status field.        |  |
| 0x10                          | Optional              | Device State Error  | This error is returned from the Target device when the current state of the Device requested does not allow it to be returned. The current state can be specified in the Optional Extended Error status field.        |  |
| 0x13                          | N/A                   | Not Enough Data   | Not enough data was supplied in the service request specified.  |  |
| 0x15                          | N/A                   | Too Much Data   | Too much data was supplied in the service request specified.  |  |

# MAINTENANCE AND TROUBLESHOOTING

---



# CHAPTER 7

## In This Chapter...

|  |      |
|--|------|
| <b>Hardware Maintenance</b> .....                          | 7-3  |
| Standard Maintenance .....                                 | 7-3  |
| Air Quality Maintenance .....                              | 7-3  |
| CPU Battery Replacement .....                              | 7-3  |
| <b>Diagnostics</b> .....                                   | 7-4  |
| Diagnostics .....  | 7-4  |
| Critical Errors .....                                      | 7-4  |
| Non-Critical Errors .....                                  | 7-4  |
| Finding Diagnostic Information .....                       | 7-4  |
| Error Codes .....  | 7-4  |
| <b>CPU Functions Indicators</b> .....                      | 7-5  |
| <b>PWR Indicator</b> .....                                 | 7-6  |
| Faulty or Incorrect Power Supply .....                     | 7-6  |
| Faulty CPU .....   | 7-6  |
| Device or Module Causes the Power Supply to Shutdown ..... | 7-7  |
| <b>Run Indicator</b> .....                                 | 7-8  |
| <b>CPU Indicator</b> .....                                 | 7-8  |
| <b>Communications Problems</b> .....                       | 7-8  |
| <b>I/O Module Troubleshooting</b> .....                    | 7-9  |
| Things to Check .....                                      | 7-9  |
| Error Codes .....  | 7-9  |
| Some Quick Steps .....                                     | 7-9  |
| Testing Output Points .....                                | 7-10 |

## Table of Contents

---

|   |      |
|---|------|
| Noise Troubleshooting .....                       | 7-11 |
| Electrical Noise Problems .....                   | 7-11 |
| Reducing Electrical Noise .....                   | 7-11 |
| Run Time vs. Stop Mode Transfer Instruction ..... | 7-12 |
| Run Time Transfers .....                          | 7-13 |
| Stop Mode Transfers .....                         | 7-13 |
| Forcing I/O Points .....                          | 7-15 |
| Advantages of Forces .....                        | 7-15 |
| Enabling Forces .....                             | 7-15 |
| Forcing Tags in Your System .....                 | 7-16 |
| Identifying Forced Values .....                   | 7-18 |
| Force Value Timing Chart .....                    | 7-19 |

## Hardware Maintenance

### Standard Maintenance

The Productivity®1000 is a low maintenance system requiring only a few periodic checks to help reduce the risks of problems. Routine maintenance checks should be made regarding two key items.

- Air quality (cabinet temperature, airflow, etc.)
- CPU battery

### Air Quality Maintenance

The quality of the air your system is exposed to can affect system performance. If you have placed your system in an enclosure, verify that the ambient temperature is not exceeding the equipment operating specifications. If there are filters in the enclosure, clean or replace them as necessary to ensure adequate airflow. A good rule of thumb is to check your system environment every one to two months. Make sure the Productivity1000 is operating within the system operating specifications.

### CPU Battery Replacement

A battery may be included with the CPU, but is not installed. The battery can be installed to retain the Time and Date along with any Tagname values that are set up as retentive.

The battery is not needed for program backup.

#### Step One:

Open battery compartment located on the top of the CPU and pull up to locked position.

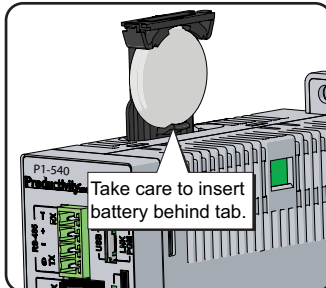
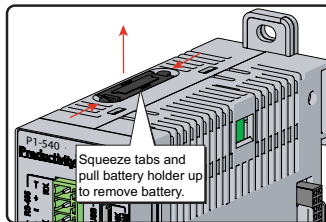

#### Step Two:

Insert battery under top two tabs in battery compartment. Press and snap battery behind bottom tab then close the battery compartment.

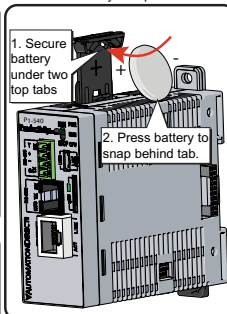

### Battery (Optional)

D2-BAT-1

Coin type, 3.0 V Lithium battery, 560mA, battery number CR2354

# Diagnostics

## Diagnostics

Your Productivity®1000 system performs many pre-defined diagnostic routines with every CPU scan. The diagnostics have been designed to detect various types of failures for the CPU and I/O modules. There are two primary error classes, critical and non-critical.

## Critical Errors

Critical errors are errors the CPU has detected that offer a risk of the system not functioning safely or properly. If the CPU is in Run Mode when a critical error occurs, the CPU will switch to Stop Mode (Remember, in Stop Mode all outputs are turned off). If a critical error is detected while the CPU is in Stop Mode, the CPU will not enter Run Mode until the error has been corrected. Here are some examples of critical errors:

- Power supply failure
- Parity error or CPU malfunction
- I/O configuration errors
- Certain programming errors.

## Non-Critical Errors

Non-critical errors are flagged by the CPU as requiring attention. They can neither cause the CPU to change from Run Mode to Stop Mode, nor do they prevent the CPU from entering Run Mode. There are system tags the application program can use to detect if a non-critical error has occurred. The application program can be used to take the system to an orderly shutdown or to switch the CPU to Stop Mode if necessary.

- Some examples of non-fatal errors are:
- Backup battery voltage low
- All I/O module errors
- Certain programming errors.

## Finding Diagnostic Information

The CPU automatically logs critical and non-critical error codes. Logged errors can be found in the following places marked with a time and date stamp:

- Under the Monitor Debug tool of Productivity Suite in the CPU Error History window. The 20 most recent critical and non-critical errors are listed.

## Error Codes

See Appendix B "Productivity1000 Error Codes" for a complete list of error messages sorted by error types.

## CPU Functions Indicators

The Productivity1000 CPUs have indicators on the faceplate to help diagnose problems with the system. The table below gives a quick reference of potential problems associated with each status indicator. The pages following the table contain a detailed analysis of each of these indicator problems.

| Indicator Status       | Potential Problems   |
|------------------------|--|
| PWR (off)              | 1. System voltage is incorrect.<br>2. Power supply/CPU is faulty.<br>3. Other components such as an I/O module has power supply shorted. |
| RUN (will not come on) | 1. CPU programming error<br>2. Switch in STOP position   |
| CPU (blink)            | CPU internal error   |

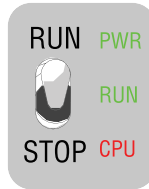
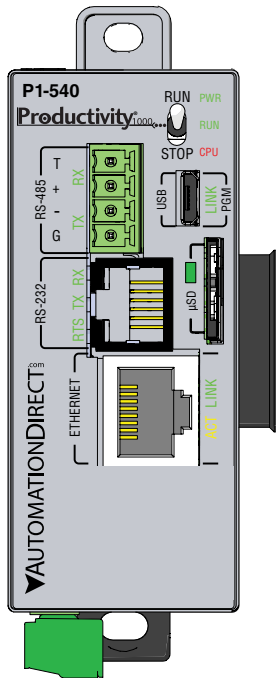

| CPU Status Indicators |  |
|-----------------------|--|
| PWR                   | Green LED is illuminated when power is on  |
| RUN                   | Green LED is illuminated when CPU is in RUN mode                                 |
| CPU                   | Red LED is illuminated during power on reset, power down, or watch-dog time-out. |

### PWR Indicator

There are three general reasons for the CPU power status LED (PWR) to be OFF:

1. Power to the module is incorrect or is not applied.
2. Module power supply is faulty.
3. Other component(s) have the power supply shut down.

### Faulty or Incorrect Power Supply

If the voltage to/from the power supply is not correct, the CPU may not operate properly or may not operate at all. Use the following guidelines to correct the problem.



---

**WARNING:** To minimize the risk of electrical shock, always disconnect the system power before inspecting the physical wiring.

---

1. First, disconnect the system power and check all incoming wiring for loose connections.
2. If you are using a separate termination panel, check those connections to make sure the wiring is connected to the proper location.
3. If the connections are acceptable, reconnect the system power and measure the voltage at the base terminal strip to ensure it is within specification. If the voltage is not correct, shut down the system and correct the problem.
4. If all wiring is connected correctly and the incoming power is within the specifications required, the power supply should be replaced.

### Faulty CPU

There is no simple test for a faulty CPU other than substituting a known good one to see if this corrects the problem. If you have experienced major power surges, it is possible the CPU and power supply have been damaged. If you suspect this is the cause, a line conditioner should be installed on the incoming line. This will keep damaging voltage spikes from reaching the CPU.

## PWR Indicator, continued

### Device or Module Causes the Power Supply to Shutdown

Module:

If the PWR LED is operating normally but the power supply shuts down, check each module for a possible connector problem as follows:

1. Turn off power to the system.
2. Remove a module from the system.
3. Reapply power to the system.
4. Check for power supply normal operation.
5. Repeat procedure until defective module is found and replaced.

Device:

A 5V charge may be originating from the CPU communications port.

Test as follows:

1. Turn off power to the CPU.
2. Disconnect all external devices (i.e., communication cables) from the CPU.
3. Reapply power.
4. If power supply operates normally then check for a shorted device or shorted cable.

### Run Indicator

If the CPU will not enter the Run mode (the RUN indicator is off), the problem is usually in the application program, unless the CPU has a critical error. If a critical error has occurred, the CPU LED should be on. You can use a programming device to determine the cause of the error.

A complete list of error codes can be found in Appendix B.

### CPU Indicator

If the CPU indicator is on, a critical error has occurred in the CPU. Generally, this is not a programming problem but an actual hardware error. The CPU indicator should blink briefly and then do an automatic reboot.

If the error clears, you should monitor the system and determine what caused the problem. You will find this problem is sometimes caused by high frequency electrical noise introduced into the CPU from an outside source. Check your system grounding and install electrical noise filters if the grounding is suspected. If power cycling the system does not reset the error, or if the problem returns, you should replace the CPU.

### Communications Problems

If a communication error occurs, the indicator will come on and stay on until a successful communication has been completed. If you cannot establish communications with the CPU, check these items:

- The cable is disconnected.
- The cable has a broken wire or has been wired incorrectly.
- The cable is improperly terminated or grounded.
- The device connected is not operating at the correct baud rate.
- The device connected to the port is sending data incorrectly.
- A grounding difference exists between the two devices.
- Electrical noise is causing intermittent errors.
- The CPU has a bad communication port; the CPU should be replaced.

# I/O Module Troubleshooting

## Things to Check

If you suspect an I/O error, there are several things that could be causing the problem.

- A blown fuse
- A loose terminal block
- The 24VDC supply has failed
- The module has failed
- The I/O configuration check detects a change in the I/O configuration

## Error Codes

See Appendix B for Productivity®1000 error code information.

Also, in the Productivity Suite programming software, you can go to:

Tools > CPU Error History, and

Tools > CPU Event History

Next, click on “CPU Error” or “Event History” tab to get an updated list of critical errors, non-critical errors and event history that should indicate problems or changes to the I/O. This list will give the “GS” (group, slot numbers).

## Some Quick Steps

When troubleshooting the Productivity1000 I/O modules there are a few facts you should be aware of which may assist you in quickly correcting an I/O problem:

- The output modules cannot detect shorted or open output points. If you suspect one or more points on a output module to be faulty, you should measure the voltage drop from the common to the suspect point. Remember, when using a Digital Volt Meter, leakage current from an output device, such as a triac or a transistor, must be considered. A point which is off may appear to be ON if no load is connected to the point.
- The I/O point status indicators on the modules are logic side indicators. This means the LED which indicates the ON or OFF status reflects the status of the point in respect to the CPU. For an output module, the status indicators could be operating normally, while the actual output device (transistor, triac etc.) could be damaged. With an input module, if the indicator LED is ON, the input circuitry should be operating properly. To verify proper functionality, check to see that the LED goes off when the input signal is removed.
- Leakage current can be a problem when connecting field devices to I/O modules. False input signals can be generated when the leakage current of an output device is great enough to turn on the connected input device. To correct this, install a resistor in parallel with the input or output of the circuit. The value of this resistor will depend on the amount of leakage current and the voltage applied but usually a 10K to 20K resistor will work. Ensure the wattage rating of the resistor is correct for your application.
- The easiest method to determine if a module has failed is to replace it if you have a spare. However, if you suspect another device to have caused the failure in the module, that device may cause the same failure in the replacement module as well. As a point of caution, you may want to check devices or power supplies connected to the failed module before replacing it with a spare module.

### Testing Output Points

Output points can be set ON or OFF using the force function to override a point even while the program is running. However, this is not a recommended method to test the output points. If you want to do an I/O check independent of the application program, follow the procedure in the table below:

| Step | Action   |
|------|--|
| 1.   | Use Productivity Suite programming software to communicate online to the CPU.  |
| 2.   | Change to Program Mode.  |
| 3.   | Go to the first rung of the ladder.  |
| 4.   | Insert a rung with an "END" statement. (This will cause program execution to occur only at address 0 and prevent the application program from turning the I/O points on or off). |
| 5.   | Change to Run Mode.  |
| 6.   | Use the programming device to set (turn) on or off the points you wish to test.  |
| 7.   | When you finish testing I/O points delete the "END" statement at the first rung.   |



**WARNING:** Depending on your application, forcing I/O points may cause unpredictable machine operation that can result in a risk of personal injury or equipment damage. Make sure you have taken all appropriate safety precautions prior to testing any I/O points.

---

# Noise Troubleshooting

## Electrical Noise Problems

Noise is one of the most difficult problems to diagnose. Electrical noise, whether conducted or radiated, can enter a system in many different ways. It may be difficult to determine how the noise is entering the system but the corrective actions for either type of noise problem are similar.

- Conducted noise is when the electrical interference is introduced into the system by way of an attached wire, panel connection, etc. It may enter through an I/O module, a power supply connection, the communication ground connection, or the chassis ground connection.
- Radiated noise is when the electrical interference is introduced into the system without a direct electrical connection, much in the same manner as radio waves.

## Reducing Electrical Noise

While electrical noise cannot be eliminated completely, it can be reduced such that it will not adversely affect system function. Proper grounding of components and signal wiring along with proper isolation of voltages can minimize noise in the system.

### 1. Grounding:

- Most noise problems result from improper grounding of the system. A good earth ground can be the single most effective way to correct noise problems. If a ground is not available, install a ground rod as close to the system as possible.
- Ensure all ground wires are single point grounds and are not daisy chained from one device to another. Ground metal enclosures around the system. A loose wire is no more than a large antenna waiting to introduce noise into the system; therefore, you should tighten all connections in your system. Loose ground wires are more susceptible to noise than the other wires in your system. Review Chapter 5, "Installation and Wiring", if you have questions regarding how to ground your system.

### 2. Isolation:

- Electrical noise can enter the system through the power source for the CPU and I/O. Installing an isolation transformer for all AC sources can correct this problem.
- DC power sources should be well grounded, good quality power supplies. Switching DC power supplies commonly generate more noise than linear supplies.
- Separate input wiring from output wiring.
- Never run I/O wiring close to high voltage wiring.

# Run Time vs. Stop Mode Transfer Instruction

Here we describe the actions and differences between Run Time & Stop Mode transfers as shown in this dialog box.

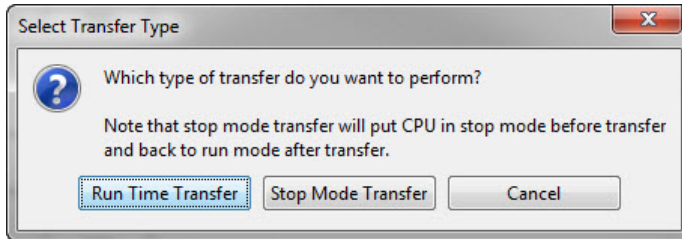

The above dialog is accessed two ways: (only when CPU is online AND in run mode)  
Perform either of the following to transfer project to the CPU:

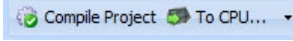
1. Click on the "To CPU" icon on the Tool Bar, or 
2. Click through from the File menu > Transfer Project > To CPU.

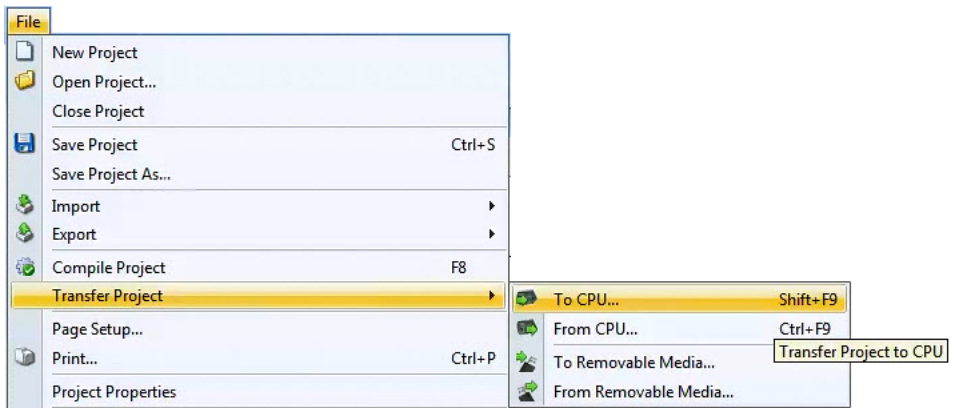

### Run Time Transfers

Run Time Transfer allows the user to transfer edits to a project in the CPU without stopping the CPU scan, therefore not stopping the process. Be aware that a Run Time Transfer will affect the length of your scan time, which should be considered if your process is susceptible to varying or lengthy scan times. The download time is longer compared to a Stop Mode transfer.

During a Run Time transfer, the current project file continues running until the entire project file is transferred to the CPU. Once downloaded, the ladder logic files swap and begin executing the new file. The Tag Database is shared between the two project files during a Run Time transfer, therefore current operating values will not be effected.

Because the Tag database is shared, any edits to the Tag database will force a Stop Mode transfer.

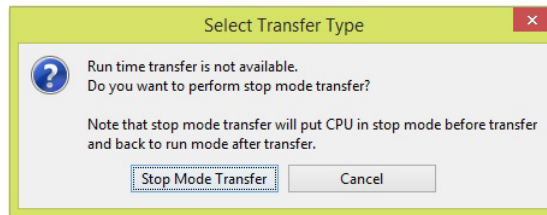

### Stop Mode Transfers

Stop Mode Transfers allows the user to transfer any and all ladder, Tag Database and configuration changes to the CPU.

Because the CPU is in stop mode, the project transfer is much faster than a Run Time Transfer and also loads all initial values to the tags once the project is switched from Stop to Run.

Following are conditions that will force the user to perform a Stop Mode Transfer:

1. Any changes to the hardware configuration, such as:
  - A. Adding or removing hardware.
  - B. Changing the configuration of a piece of hardware.
    - Ethernet or serial port configuration.
  - C. Adding an EhterNet/IP device and any configured changes
2. Adding > 5000 tags of any type (Excluding Strings and Structures).

---

**NOTE:** This limit is accumulated between each stop mode transfer.

---

3. Adding >50,000 characters or changing the length of a **String** data type Tag.

---

**NOTE:** This limit is accumulated between each stop mode transfer.

---

4. Changes to Data Logger.
5. Changes to Modbus Server settings under **Project Properties**.



6. Changes to the buffer size for a FILI instruction.
7. Adding >5,000 elements of a **Structures** data type to **Tag Database**.



**NOTE:** This limit is accumulated between each stop mode transfer.

8. Enabling **Bit of Word** under **Project Properties**.
9. Enabling Structures in **Project Properties**.
10. Enable and Disable of **EhterNet/IP Adapter**.

As the CPU goes from Stop to Run after a Stop Mode Transfer, tags are initialized as if the project is being executed for the first time. This includes Retentive Tags. If it's desirable that the values of Retentive Tags be retained through a Stop Mode Transfer, there are two methods available. Both options may be enabled and they can be found under Tools > Options > Project Transfer

1. Upload current retentive values and copy to initial values. This option works during program upload. When selected, place the CPU in Stop Mode so Retentive Tag values are stable, then upload the project. Productivity Suite will copy the current value of all Retentive Tags to their Initial Values in the Tag Database of the project. Perform your edits and transfer the project back to the CPU. When the CPU goes back to run, your Retentive Tags will be initialized with their old values. This is a simple process and is convenient for quick edits to the program, but the CPU must remain in Stop Mode while the project is edited to ensure that no retentive values have changed during editing.
2. Copy current retentive tag values to initial values. This option works during program download. This process is more involved, but the CPU will use the values from the project currently running as the initial values of the project being transferred. For more information refer to the Options topic in the help file.

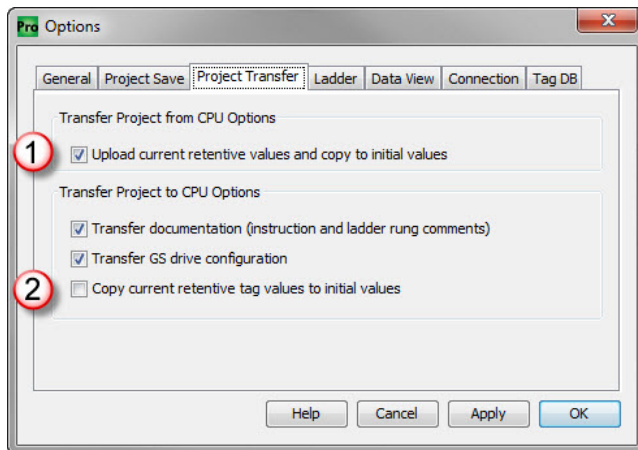

## Forcing I/O Points

Following is a description of the actions, expectations and indications of forcing a value in the Productivity®1000 controller.

### Advantages of Forces

Almost all tags can be written to in the software without Forcing. However, if the ladder logic or an external device (operator interface panel, Modbus device, etc.) is connected to your controller and writing to those tags, the values you write from a Data View will be over-written. Conversely, if you write a Forced value, this will not be overwritten or reset until you manually remove the force or reset by means of a Stop to Run mode transition, a Stop Mode Transfer, or a controller power cycle.

### Enabling Forces

The Productivity1000 CPU is a Tag based controller where forcing a tag begins by identifying any tag you wish to be "Force-able" within the Tag database.

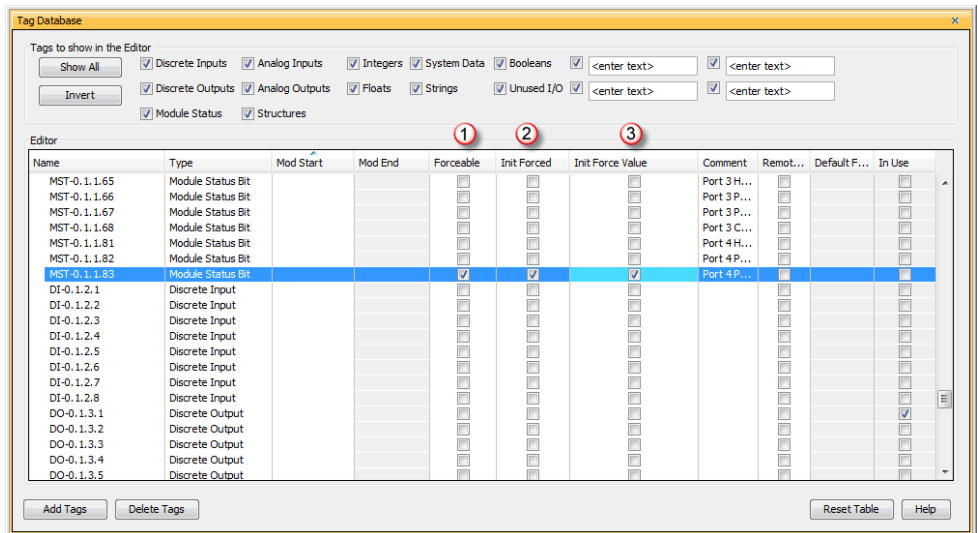

## Chapter 7: Maintenance and Troubleshooting

There are three columns within the Tag database that affect the forcing of all tags.

1. "Forceable" - Checking the box in this column identifies the corresponding tag as being able to be forced within the system.
2. "Init Forced" - Checking the box in this column identifies that corresponding tag as being forced as soon as the project is loaded and the processor is switched to Run mode.
3. "Init Force Value" - The state of the box in this column identifies the initial forced state of the Boolean tag:
  - A check mark in a box equates to a logical "1" or "ON", and
  - An unchecked box equates to a logical "0" or "OFF". The value placed in this field for Integer or Floating point tags will be written into the tag.

### Forcing Tags in Your System

All forcing of tags can be accomplished through the Data View window or directly in the program interface while in "Monitor" mode, as long as the "Forceable" box has been checked in Tag Database. I/O may also be directly forced in I/O View by clicking on individual I/O points.

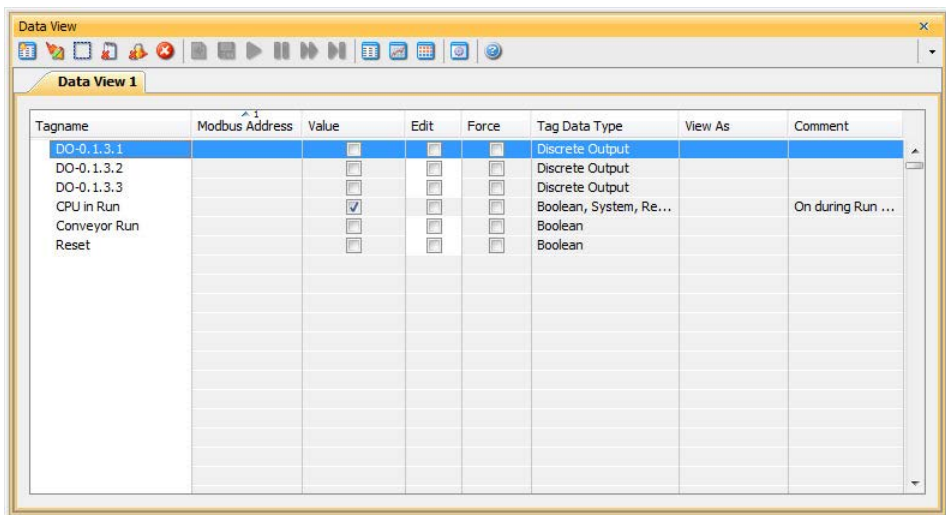

From the DataView Window, enter the tags you wish to force, or you can view all forceable tags from the "Forceable Tags" tab automatically created for you when you enable tags as forceable in the tag database.

| Tagname        | Modbus Address | Value | Edit                                | Force                               | Tag Data Type          | View As |
|----------------|----------------|-------|-------------------------------------|-------------------------------------|------------------------|---------|
| MST-0.1.1.81   |                |       | <input type="checkbox"/>            | <input type="checkbox"/>            | Module Status Bit      |         |
| MST-0.1.1.82   |                |       | <input type="checkbox"/>            | <input type="checkbox"/>            | Module Status Bit      |         |
| MST-0.1.1.83   |                |       | <input checked="" type="checkbox"/> | <input type="checkbox"/>            | Module Status Bit      |         |
| DI-0.1.2.1     |                |       | <input checked="" type="checkbox"/> | <input type="checkbox"/>            | Discrete Input         |         |
| DI-0.1.2.2     |                |       | <input type="checkbox"/>            | <input type="checkbox"/>            | Discrete Input         |         |
| DI-0.1.2.3     |                |       | <input type="checkbox"/>            | <input type="checkbox"/>            | Discrete Input         |         |
| DI-0.1.2.4     |                |       | <input type="checkbox"/>            | <input type="checkbox"/>            | Discrete Input         |         |
| Was_DO-0.1.3.1 |                |       | <input type="checkbox"/>            | <input type="checkbox"/>            | Discrete Output        |         |
| Was_DO-0.1.3.2 |                |       | <input type="checkbox"/>            | <input type="checkbox"/>            | Discrete Output        |         |
| Was_DO-0.1.3.3 |                |       | <input type="checkbox"/>            | <input type="checkbox"/>            | Discrete Output        |         |
| Was_DO-0.1.3.4 |                |       | <input type="checkbox"/>            | <input type="checkbox"/>            | Discrete Output        |         |
| AOS32-0.1.5.2  |                | 0     | <input type="checkbox"/>            | <input type="checkbox"/>            | Analog Output, Inte... | Decimal |
| AOS32-0.1.5.3  |                | 0     | <input type="checkbox"/>            | <input type="checkbox"/>            | Analog Output, Inte... | Decimal |
| AOS32-0.1.5.4  |                | 0     | <input type="checkbox"/>            | <input type="checkbox"/>            | Analog Output, Inte... | Decimal |
| AOS32-0.1.5.6  |                | 0     | <input type="checkbox"/>            | <input type="checkbox"/>            | Analog Output, Inte... | Decimal |
| MST-0.1.5.26   |                |       | <input checked="" type="checkbox"/> | <input type="checkbox"/>            | Module Status Bit      |         |
| MST-0.1.5.25   |                |       | <input type="checkbox"/>            | <input type="checkbox"/>            | Module Status Bit      |         |
| DO-0.1.3.1     |                |       | <input type="checkbox"/>            | <input checked="" type="checkbox"/> | Discrete Output        |         |
| DO-0.1.3.15    |                |       | <input type="checkbox"/>            | <input type="checkbox"/>            | Discrete Output        |         |
| DO-0.1.3.14    |                |       | <input type="checkbox"/>            | <input type="checkbox"/>            | Discrete Output        |         |
| DO-0.1.3.13    |                |       | <input type="checkbox"/>            | <input type="checkbox"/>            | Discrete Output        |         |
| DO-0.1.3.12    |                |       | <input type="checkbox"/>            | <input type="checkbox"/>            | Discrete Output        |         |
| DO-0.1.3.11    |                |       | <input type="checkbox"/>            | <input type="checkbox"/>            | Discrete Output        |         |
| DO-0.1.3.10    |                |       | <input type="checkbox"/>            | <input type="checkbox"/>            | Discrete Output        |         |
| DO-0.1.3.9     |                |       | <input type="checkbox"/>            | <input type="checkbox"/>            | Discrete Output        |         |
| DO-0.1.3.8     |                |       | <input type="checkbox"/>            | <input type="checkbox"/>            | Discrete Output        |         |

From either of these windows you have the option to select the check box in the Force column. When this box is checked and the row is selected (selected rows show highlighted blue) and you select the Send Edit(s) button, the current row(s) will be forced.



**NOTE:** You can select multiple rows by clicking and holding down the left mouse button and dragging up or down. This selects consecutive rows. If you wish to select various rows, simply hold the "Ctrl" control key on your keyboard while left mouse clicking the rows.

### Identifying Forced Values

There are two indications that forces are active on your controller.

1. All active forces will be shown in the Force-able tab of the Data View window as shown in the previous view.
2. You will also see “CPU Data Forced” in Red in the lower right of the Status bar of your software interface.

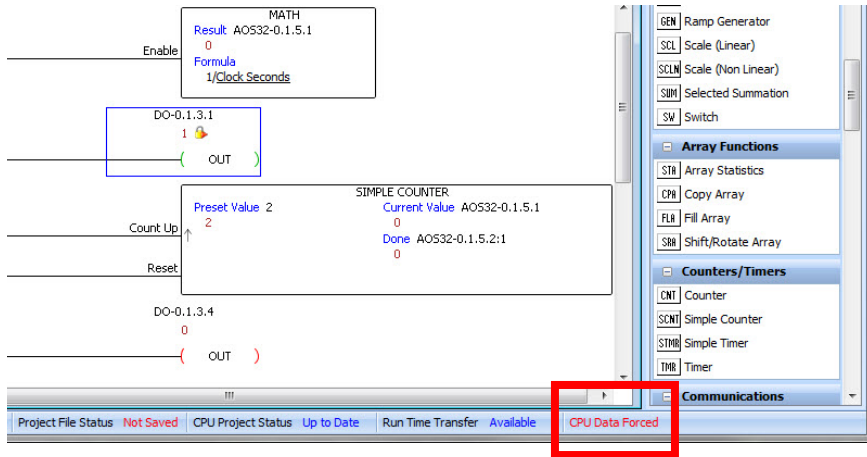

**NOTE:** Only Forced tags with an initial force value specified in the Tag database will be retained after a Stop to Run transition, Stop Mode transfer, or a power cycle. All forced values are retained during a Run Time transfer.

## Force Value Timing Chart

The chart below illustrates how the states of a discrete output are varied when forces and edits are applied. The ladder rung at the top of the chart (a) shows the logical arrangement of Logical Contact1 and discrete Output DO-0.1.3.1.

Under normal operation, Logical Contact1 (b) is driven by a clock pulse. This clock pulse is then fed to the discrete Output DO-0.1.3.1 (c). Edits written to the contact or the coil from the Data View window within the software will be written one time and will not be forced. With the clock pulse driving the contact, any software edits made to this contact will be allowed but will be overwritten by the logic on the very next scan. Any software edits made to the output will not be allowed and will not register. Edits can only change the state of the output if there are no other logistic or outside factors influencing the output.

In order to change the state of Logical Contact1 or discrete Output DO-0.1.3.1 while the clock pulse is driving it, a force must be introduced. The DO-0.1.3.1 Output Edit line (d) represents edits sent to the discrete output from the Data View window. The DO-0.1.3.1 Output Force Enabled line (e) shows the point at which the software forces the output edit to take effect. The dotted lines represent the force being enabled and then disabled by the user. When the force is enabled, any edits made will register at the output regardless of the state of Logical Contact1. When the force is disabled, all output edits will be ignored.

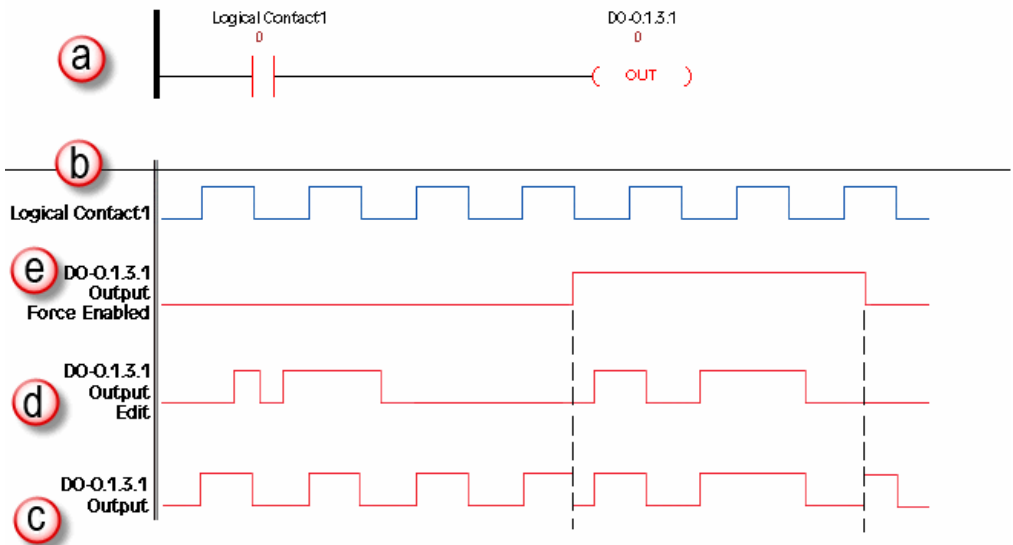

# EUROPEAN UNION DIRECTIVES (CE)

---



## In This Appendix...

|  |            |
|--|------------|
| <b>European Union (EU) Directives.....</b>     | <b>A-2</b> |
| Member Countries .....                         | A-2        |
| Applicable Directives.....                     | A-2        |
| Compliance .....                               | A-2        |
| General Safety.....                            | A-4        |
| Special Installation Manual.....               | A-4        |
| Other Sources of Information.....              | A-4        |
| <b>Basic EMC Installation Guidelines .....</b> | <b>A-5</b> |
| Enclosures.....                                | A-5        |
| Mains Filters.....                             | A-5        |
| Suppression and Fusing.....                    | A-5        |
| Internal Enclosure Grounding.....              | A-5        |
| Equipotential Grounding.....                   | A-5        |
| Communications and Shielded Cables .....       | A-6        |
| Analog and RS232 Cables.....                   | A-7        |
| Multidrop Cables .....                         | A-7        |
| Shielded Cables Within Enclosures .....        | A-7        |
| Analog Modules and RF Interference.....        | A-7        |
| Network Isolation.....                         | A-8        |
| Items Specific to the Productivity®1000.....   | A-9        |

# European Union (EU) Directives



**NOTE:** *The information contained in this section is intended as a guideline and is based on our interpretation of the various standards and requirements. Since the actual standards are issued by other parties, and in some cases governmental agencies, the requirements can change over time without advance warning or notice. Changes or additions to the standards can possibly invalidate any part of the information provided in this section.*

---

This area of certification and approval is absolutely vital to anyone who wants to do business in Europe. One of the key tasks that faced the EU member countries and the European Economic Area (EEA) was the requirement to bring several similar yet distinct standards together into one common standard for all members. The primary purpose of a single standard was to make it easier to sell and transport goods between the various countries and to maintain a safe working and living environment. The Directives that resulted from this merging of standards are now legal requirements for doing business in Europe. Products that meet these Directives are required to have a CE mark to signify compliance.

## Member Countries

As of January 1, 2015, the members of the EU are Austria, Belgium, Bulgaria, Croatia, Republic of Cyprus, Czech Republic, Denmark, Estonia, Finland, France, Germany, Greece, Hungary, Ireland, Italy, Latvia, Lithuania, Luxembourg, Malta, Netherlands, Poland, Portugal, Romania, Slovakia, Slovenia, Spain, and Sweden. Iceland, Liechtenstein, and Norway together with the EU members make up the European Economic Area (EEA) and all are covered by the Directives. The UK accepts the EU CE and/or UKCA mark for compliance.

## Applicable Directives

There are several Directives that apply to our products. Directives may be amended, or added, as required.

- Electromagnetic Compatibility Directive (EMC) — this Directive attempts to ensure that devices, equipment, and systems have the ability to function satisfactorily in an electromagnetic environment without introducing intolerable electromagnetic disturbance to anything in that environment.
- Machinery Safety Directive — this Directive covers the safety aspects of the equipment, installation, etc. There are several areas involved, including testing standards covering both electrical noise immunity and noise generation.
- Low Voltage Directive — this Directive is also safety related and covers electrical equipment that has voltage ranges of 50–1000 VAC and/or 75–1500 VDC.
- Battery Directive — this Directive covers the production, recycling, and disposal of batteries.

## Compliance



**NOTE:** *As of July 22, 2017 ROHS has been added as an additional requirement for CE Compliance per Directive 2011/65/EU. All products bearing the CE mark must be ROHS compliant.*

---

Certain standards within each Directive already require mandatory compliance. The EMC Directive, which has gained the most attention, became mandatory as of January 1, 1996. The Low Voltage Directive became mandatory as of January 1, 1997.

Ultimately, we are all responsible for our various pieces of the puzzle. As manufacturers, we

## Appendix A: European Union Directives (CE)

must test our products and document any test results and/or installation procedures that are necessary to comply with the Directives. As a machine builder, you are responsible for installing the products in a manner which will ensure compliance is maintained. You are also responsible for testing any combinations of products that may (or may not) comply with the Directives when used together. The end user of the products must comply with any Directives that may cover maintenance, disposal, etc., of equipment or various components. *Although we strive to provide the best assistance available, it is impossible for ADC to test all possible configurations of our products with respect to any specific Directive. Because of this, it is ultimately your responsibility to ensure that your machinery (as a whole) complies with these Directives and to keep up with applicable Directives and/or practices that are required for compliance.*

This then is the product specific standard for CPUs and covers the low voltage and EMC directives as required for European CE certification. This standard has many tests together with test procedures and limits, but also references the below standards for some tests.

Productivity®1000 systems, manufactured by FACTS Engineering, when properly installed

| IEC 60068                | IEC 60417  | IEC 60664              | IEC 60695               | IEC 60707 | IEC 60947         | IEC 60950     | IEC 61000           | IEC 61010     |
|--------------------------|--|------------------------|-------------------------|-----------|-------------------|---------------|---------------------|---------------|
| 2-1:1990 part 2 Test A   | All Parts  | 1:1992 Part 1          | 2-1 (all sheets) Part 2 | :1999     | 5-1:1997 Part 5-1 | 1:2001 Part 1 | 4-2:1995 Part 4-2   | 1:2001 Part 1 |
| 2-2:1974 part 2 Test B   |  | 3:1992                 |                         |           | 7-1:2002 Part 7-1 |               | 4-3:2002 Part 4-3   |               |
| 2-6:1995 Part 2: Test Fc |  |                        |                         |           |                   |               | 4-4:1995            |               |
| 2-6:1995 Part 2: Test Fc |  | CISPR 11:1999          |                         |           |                   |               | 4-5:1995 Part 4-5   |               |
| 2-14:1984 Part 2 Test N  |  | CISPR 16-1:1999 Part 1 |                         |           |                   |               | 4-6:1996 Part 4-6   |               |
| 2-27:1987 Part 2 Test Ea |  | CISPR 16-2:1999 Part 2 |                         |           |                   |               | 4-8:1993 Part 4-8   |               |
| 2-30:1980 Part 2 Test Db | <b>For undated references, the latest edition of the referenced document (including any amendments) applies.</b> |                        |                         |           |                   |               | 4-12:1995 Part 4-12 |               |
| 2-31:1969 Part Test Ec   |  |                        |                         |           |                   |               |                     |               |
| 2-32:1975 Part 2 Test Ed |  |                        |                         |           |                   |               |                     |               |

and used, conform to the Electromagnetic Compatibility (EMC), Low Voltage Directive, and Machinery Directive requirements of the following standards:

- Product Specific Standard for Programmable Controllers  
EN61131-2:2007 EMC, EN61010-2010 and EN61010-2-201: 2013 Safety Programmable controllers, equipment requirements and tests.
- Warning on Electrostatic Discharge (ESD)

## Appendix A: European Union Directives (CE)

---

We recommend that all personnel take necessary precautions to avoid the risk of transferring static charges to inside the control cabinet, and clear warnings and instructions should be provided on the cabinet exterior. Such precautions may include the use of earth straps, grounding mats and similar static-control devices, or the powering off of the equipment inside the enclosure before the door is opened.

- Warning on Radio Interference (RFI)  
This is a class A product. In a domestic environment this product may cause radio interference in which case the user may be required to take adequate measures.

### General Safety

- External switches, circuit breaker or external fusing, are required for these devices.
- The switch or circuit breaker should be mounted near the programmable controller equipment.

### Special Installation Manual

The installation requirements to comply with the requirements of the Machinery Directive, EMC Directive and Low Voltage Directive are slightly more complex than the normal installation requirements found in the United States.

### Other Sources of Information

Although the EMC Directive gets the most attention, other basic Directives, such as the Machinery Directive and the Low Voltage Directive, also place restrictions on the control panel builder. Because of these additional requirements it is recommended that the following publications be purchased and used as guidelines:

- BSI publication BS TH 42073: November 2000 – covers the safety and electrical aspects of the Machinery Directive
- EN 60204–1:2006 – Safety of Machinery; General electrical requirements for machinery, including Low Voltage and EMC considerations
- IEC 61000–5–2: EMC earthing and cabling requirements
- IEC 61000–5–1: EMC general considerations

It may be possible for you to obtain this information locally; however, the official source of applicable Directives and related standards is:

Publications Office  
2, rue Mercier  
2985 Luxembourg  
LUXEMBOURG

Quickest contact is via the web at:

<http://ec.europa.eu/growth/single-market/european-standards/harmonised-standards>.

Another source is the British Standards Institution at:

British Standards Institution – Sales Department, Linford Wood:  
Milton Keynes, MK14 6LE, United Kingdom.

The quickest contact is via the web at [www.bsigroup.com](http://www.bsigroup.com)

# Basic EMC Installation Guidelines

## Enclosures

In order to meet the safety requirements of the Machinery and Low Voltage Directives install all control equipment in an industry standard lockable steel enclosure. This normally has an added benefit because it will also help to reduce EMI emissions. Per IEC/EN 61131-2, the PLC is tested in a metal enclosure. The levels of RF emission is actually higher outside of cabinet and may be well above limits. Holes in the enclosure, for the passage of cables or to mount operator interfaces, may contribute to an increase in internal RF levels.

## Mains Filters

Productivity®1000 AC powered power supplies do not require extra mains filtering to comply with the EMC Directive on conducted RF emissions.

## Suppression and Fusing

In order to comply with the fire risk requirements of the Low Voltage and Machinery Directive standards EN 61010-1 and EN 60204-1, it is necessary to fuse both sides of the power inputs (on both AC and DC units).

Transient suppressors must be protected by fuses and the capacity of the transient suppressor must be greater than the blow characteristics of the fuses or circuit breakers to avoid a fire risk. A recommended AC supply input arrangement for the Productivity1000 is to use twin 3 amp TT fused terminals with fuse blown indication, such as DINnectors DN-F10L terminals, or twin circuit breakers.

## Internal Enclosure Grounding

A heavy-duty star earth terminal block should be provided in every cubicle for the connection of all earth ground straps, protective earth ground connections, mains filter earth ground wires, and mechanical assembly earth ground connections. This should be installed to comply with safety and EMC requirements, local standards, and the requirements found in IEC 61000-5-2. The Machinery Directive also requires that the common terminals of the programmable controller input modules, and common supply side of loads driven from programmable controller output modules should be connected to the protective earth ground terminal.

## Equipotential Grounding

Adequate site earth grounding must be provided for equipment containing modern electronic circuitry. The use of isolated earth electrodes for electronic systems is forbidden in some countries. Make sure you check any requirements for your particular destination. IEC 61000-5-2 covers equipotential bonding of earth grids adequately, but special attention should be given to apparatus and control cubicles that contain I/O devices, remote I/O racks, or have inter-system communications with the primary CPU system enclosure.

An equipotential bond wire must be provided alongside all serial communications cables, and to any separate items of the plant which contain I/O devices connected to the programmable controller. The diagram shows an example of four physical locations connected by a communications cable.

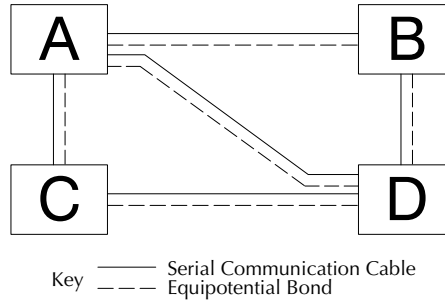

### Communications and Shielded Cables

Good quality 24AWG minimum twisted-pair shielded cables, with overall foil and braid shields are recommended for analog cabling and communications cabling outside of the programmable controller enclosure. To date it has been a common practice to only provide an earth ground for one end of the cable shield in order to minimize the risk of noise caused by earth ground loop currents between apparatus. The procedure of only

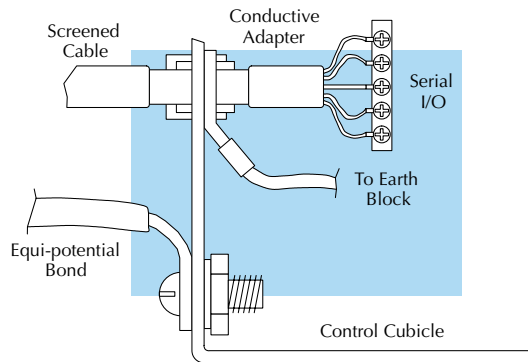

grounding one end, which primarily originated as a result of trying to reduce hum in audio systems, is no longer applicable to the complex industrial environment. Shielded cables are also efficient emitters of RF noise from the CPU system, and can interact in a parasitic manner in networks and between multiple sources of interference.

The recommendation is to use shielded cables as electrostatic “pipes” between apparatus and systems, and to run heavy gauge equipotential bond wires alongside all shielded cables. When a shielded cable runs through the metallic wall of an enclosure or machine, it is recommended in IEC 61000–5–2 that the shield should be connected over its full perimeter to the wall, preferably using a conducting adapter, and not via a pigtail wire connection to an earth ground bolt. Shields must be connected to every enclosure wall or machine cover that they pass through.

### Analog and RS232 Cables

Providing an earth ground for both ends of the shield for analog circuits provides the perfect electrical environment for the twisted pair cable as the loop consists of signal and return, in a perfectly balanced circuit arrangement, with connection to the common of the input circuitry made at the module terminals. RS232 cables are handled in the same way.

### Multidrop Cables

RS422 twin twisted pair, and RS485 single twisted pair cables also require a 0V link, which has often been provided in the past by the cable shield. It is now recommended that you use triple twisted pair cabling for RS422 links, and twin twisted pair cable for RS485 links. This is because the extra pair can be used as the 0V inter-system link. With loop DC power supplies earth grounded in both systems, earth loops are created in this manner via the inter-system 0v link.

The installation guides encourage earth loops, which are maintained at a low impedance by using heavy equipotential bond wires. To account for non-European installations using single-end earth grounds, and sites with far from ideal earth ground characteristics, we recommend the addition of 100 ohm rated resistors at each 0V link connection in network and communications cables.

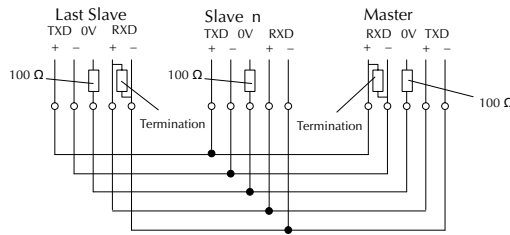

### Shielded Cables Within Enclosures

When you run cables between programmable controller items within an enclosure which also contains susceptible electronic equipment from other manufacturers, remember that these cables may be a source of RF emissions. There are ways to minimize this risk. Standard data cables connecting CPUs and/or operator interfaces should be routed well away from other equipment and their associated cabling. You can make special serial cables where the cable shield is connected to the enclosure's earth ground at both ends, the same way as external cables are connected.

### Analog Modules and RF Interference

The readings from all analog modules will be affected by the use of devices that exhibit high field strengths, such as mobile phones and motor drives.

All AutomationDirect products are tested to withstand field strength levels up to 10V/m, which is the maximum required by the relevant EU standards. While all products pass this test, analog modules will typically exhibit deviations of their readings. This is quite normal, however, systems designers should be aware of this and plan accordingly.

When assembling a control system using analog modules, these issues must be adhered to and should be integrated into the system design. This is the responsibility of the system builder/commissioner.

### Network Isolation

For safety reasons, it is a specific requirement of the Machinery Directive that a keyswitch must be provided that isolates any network input signal during maintenance, so that remote commands cannot be received that could result in the operation of the machinery. To avoid the introduction of noise into the system, any keyswitch assembly should be housed in its own earth grounded steel box and the integrity of the shielded cable must be maintained.

Again, for further information on EU directives we recommend that you check the EU Commission's official web site at:

<http://ec.europa.eu/growth/single-market/european-standards/harmonised-standards>.

It is good Engineering practice to install toroid inductors on the I/O wiring and the communications cables such as listed in the table below.

| Toroid Inductors |                  |                  |                 |         |
|------------------|------------------|------------------|-----------------|---------|
| Manufacturer     | Mfg. Part Number | Outside Diameter | Inside Diameter | Length  |
| RS Online        | 2606795          | 17.5 mm          | 9.5 mm          | 28.5 mm |
| Fair-Rite        | 2643665702       | 17.45 mm         | 9.5 mm          | 28.6 mm |
| Würth Elektronik | 7427009          | 17.5 mm          | 9.5 mm          | 28.5 mm |

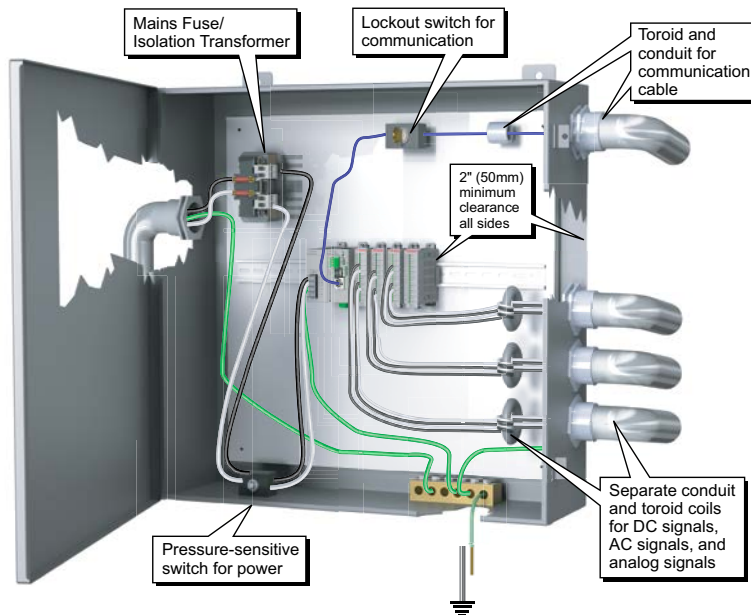

### Items Specific to the Productivity®1000

- It is the responsibility of the system designer to earth one side of all control and power circuits, and to earth the braid of screened cables.
- This equipment must be properly installed while adhering to the guidelines of the installation standards IEC 61000-5-1, IEC 61000-5-2 and IEC 61131-4.
- It is a requirement that all CPU equipment must be housed in a protective steel enclosure, which limits access to operators by a lock and power breaker. If access is required by operators or untrained personnel, the equipment must be installed inside an internal cover or secondary enclosure.
- It should be noted that the safety requirements of the machinery directive standard EN60204-1 state that all equipment power circuits must be wired through isolation transformers or isolating power supplies, and that one side of all AC or DC control circuits must be earthed.
- Both power input connections to the programmable controller must be separately fused using 3 amp T-type anti-surge fuses, and a transient suppressor fitted to limit supply overvoltages.
- If the equipment is used in a manner not specified by the manufacturer the protection provided by the equipment may be impaired.

# PRODUCTIVITY® 1000 ERROR CODES

---



## In This Appendix...

|                                 |     |
|---------------------------------|-----|
| Communications Error Codes..... | B-2 |
| Module Error Codes .....        | B-3 |
| CPU Error Codes.....            | B-4 |
| Project Error Codes .....       | B-5 |
| Project Error Messages.....     | B-7 |

## Communications Error Codes

| Error Code | Description  | Suggested Fix   |
|------------|--|---|
| 01         | Function Code not supported  | Check instruction or connected device and correct Function code or address range selected.  |
| 02         | Address out of range. This error is typically generated when a Modbus address has been requested that does not exist in the CPU. | Check instruction or connected device and correct Function code or address range selected.  |
| 03         | Illegal Data Value. This error is typically generated when the Modbus request sent to the CPU is formed incorrectly.             | Check the Modbus request against the Modbus protocol specification ( <a href="http://www.modbus.org">www.modbus.org</a> ) to verify that it was formed correctly. |
| 04         | Device Failure   | Check connected device  |

## Module Error Codes

| Error Code | Cause   | Solution  |
|------------|---|---|
| E02101     | One or more module status bits are set.                                 | Examine the individual module status bits for the module(s) in question to determine the cause of the error and appropriate action.   |
| E02110     | Module firmware is incompatible with project.                           | Recompile and transfer project to CPU. If problem persists, upgrade module firmware to latest version, then recompile and transfer project using latest Programming Software.                                   |
| E02111     | Module firmware is incompatible with project.                           | Recompile and transfer project to CPU. If problem persists, upgrade module firmware to latest version, then recompile and transfer project using latest Programming Software.                                   |
| E02112     | Module configuration data is invalid.                                   | Recompile and transfer project to CPU. If problem persists, upgrade module firmware to latest version, then recompile and transfer project using latest Programming Software.                                   |
| E02113     | Module configuration data is invalid.                                   | Recompile and transfer project to CPU. If problem persists, upgrade module firmware to latest version, then recompile and transfer project using latest Programming Software.                                   |
| E02114     | Unable to configure module.   | Restart CPU. If problem persists, recompile and transfer project to CPU. If problem persists, upgrade module firmware to latest version, then recompile and transfer project using latest Programming Software. |
| E02115     | Unable to configure module.   | Restart CPU. If problem persists, recompile and transfer project to CPU. If problem persists, upgrade module firmware to latest version, then recompile and transfer project using latest Programming Software. |
| E02210     | Too many modules G000   | P1 CPU only supports 8 modules at a time. Remove power and remove all modules past the 8th module.  |
| E02301     | Expected module is not installed, or the installed module is defective. | Install the correct module.   |
| E02302     | Expected module is not installed, or the installed module is defective. | Install the correct module.   |

## CPU Error Codes

| Error Code | Cause                                       | Solution  |
|------------|---|---|
| E05101     | The CPU battery is low.                     | Replace CPU's Battery.  |
| E05106     | I2C bus has locked up.                      | Self-recoverable. If problem persists, restart system.                            |
| E05120     | The module specified has a Firmware Error.  | Replace the unit. If unit is in warranty, call AutomationDirect for an RA number. |
| E05121     | The module specified has a Hardware Error.  | Replace the unit. If unit is in warranty, call AutomationDirect for an RA number. |
| E05122     | The module specified has an Internal Error. | Replace the unit. If unit is in warranty, call AutomationDirect for an RA number. |

## Project Error Codes

| Error Code      | Cause  | Solution   |
|-----------------|--|--|
| E03000 - E03199 | Internal firmware file system error.   | Power cycle CPU. If problem persists, contact AutomationDirect for repair or replacement.                            |
| E03201 - E03299 | Internal firmware operating system error.  | Power cycle CPU. If problem persists, contact AutomationDirect for repair or replacement.                            |
| E03301          | Unable to exit RUN mode.   | Power cycle CPU. If problem persists, contact AutomationDirect for repair or replacement.                            |
| E03801 - E03899 | Internal firmware USB error.   | Problem should self recover. If problem persists, power cycle CPU.   |
| E03901          | A scan exceeded the timeout specified in CPU Hardware Configuration.               | Verify that For/Next loops are handled properly. Adjust the timeout setting.   |
| E04101          | Scan attempted access beyond array limits. Txxxx is task ID. Rxxxx is rung number. | Correct problem in ladder logic or data that caused invalid access.  |
| E04201          | Internal firmware Data Logging error.  | Problem should self recover. If problem persists, power cycle CPU.   |
| E04202          | Cannot create data logging folder.   | Ensure a supported storage device is properly installed in USB OUT port on CPU. If problem persists, restart system. |
| E04203          | Cannot write data to data logging storage device.                                  | Ensure a supported storage device is properly installed in USB OUT port on CPU. If problem persists, restart system. |
| E04204          | Internal firmware Data Logging buffer is greater than 50% full.                    | Problem should self recover. If problem persists, power cycle CPU.   |
| E04205          | Internal firmware Data Logging buffer overflow.                                    | Problem should self recover. If problem persists, power cycle CPU.   |
| E04210          | Invalid system ID found while loading project.                                     | Load new project.  |
| E04220          | Email instruction failed.  | Problem should self recover. If problem persists, power cycle CPU.   |
| E04300 - E04302 | A project file is missing.   | Load new project.  |
| E04303          | Internal firmware project loader failure.  | Problem should self recover. If problem persists, power cycle CPU.   |
| E04304          | Project load failure limit exceeded. Project has been removed.                     | Load new project.  |
| E04305 - E04306 | Internal firmware project loader failure.  | Problem should self recover. If problem persists, power cycle CPU. If problem persists, load new project.            |
| E04307          | Project file corrupt.  | Load new project.  |
| E04308 - E04315 | Internal firmware project loader failure.  | Load new project.  |

## Project Error Codes - Continued

| Error Code | Cause  | Solution   |
|------------|--|--|
| E04316     | Project upload failed.                               | Retry the process.   |
| E04317     | Internal firmware project loader failure.,           | Load new project.  |
| E04318     | Modbus TCP connection limit exceeded.                | Reduce the number of concurrently enabled MRX, MWX, RX and WX Instructions to no more than 64. |
| E04319     | Internal error.                                      | Self-recoverable, if problem persists restart CPU.   |
| E04320     | One or more RS232 parameters contain invalid values. | Verify that all RS232 parameters in project contain valid settings.                            |
| E04321     | One or more RS485 parameters contain invalid values. | Verify that all RS485 parameters in project contain valid settings.                            |

## Project Error Messages

| Error Message   | Cause   | Solution  |
|---|---|---|
| Cannot create a task with the name '<taskname>' because a task with that name already exists. | The name of the new task already exists.  | Create a unique task name.  |
| The help file '<helpfilename>' cannot be found.   | The help file cannot be found in the location that it was installed.  | Re-install the software. The ProductivitySuite Help file: P3-HELP.chm should be located in the following folder: C:\ProgramFiles\AutomationDirect\ProductivitySuite x.x.x\data\help |
| The topic '<topicname>' does not exist.   | A referenced help topic has either been changed, moved, or deleted from the help file.                          | Re-install the software or download the Latest Help File version.   |
| Task name cannot be empty.  | An attempt was made to create a task without a task name.   | Create a unique task name.  |
| The task name has an invalid character '<taskname>'.  | An attempt was made to create a task with an invalid character in the name.                                     | Create a unique task name using valid characters only.  |
| The task name '<taskname>' already exists.  | The name of the new task already exists.  | Create a unique task name.  |
| Tagname cannot be all digits.   | A tagname that consists of only digits was entered.   | There must be at least one letter in a tagname.   |
| Cannot complete the operation because the P1-540/550 folder already exists.                   | The P1-540/550 folder already exists on the target removable USB drive and the create folder option is checked. | Uncheck the create folder option in the dialog and try transfer again.  |
| Cannot complete the operation because the P1-540/550 folder does not exist.                   | The P1-540/550 folder does not exist on the target removable USB drive and the create option is not checked.    | Check the create folder option in the dialog and try transfer again.  |
| Cannot complete the operation due to failure to create the P1-540/550 folder.                 | System could not create the P1-540/550 folder.  | This might be due to a read only drive.   |
| Failed to reboot CPU.   | CPU failed to reboot.   | Reboot CPU again or cycle power.  |
| Failed to get CPU date & time from CPU.   | CPU failed to return date & time data.  | Check CPU to PC connection.   |
| Failed to set CPU date & time.  | CPU failed to set date & time.  | Check CPU to PC connection.   |
| CPU does not exist.   | A CPU does not exist in the configuration.  | Add a CPU to the hardware configuration or connect to the CPU and select "read configuration" in the Hardware Configuration dialog.   |
| Rebooting the CPU failed.   | CPU failed to reboot.   | Reboot CPU again or Cycle power   |
| The IP address '<IP Address>' is already on the network. Please use a different address.      | The new CPU IP address is used by another entity on the network.  | Select a unique IP address. You may need to contact your networks IT department to verify.  |
| Cannot change CPU name.   | Failed to change CPU name due to a CPU error or a network problem   | Check CPU to PC connection.   |

## Project Error Messages - Continued

| Error Message  | Cause   | Solution   |
|--|---|--|
| Cannot change IP configuration due to CPU error.                           | CPU failed to change IP configuration.                                      | Check CPU to PC connection and network configuration. Connections through a router may also cause conflicts. |
| Cannot change IP configuration due to network problem.                     | CPU failed to respond to the IP configuration request.                      | Check CPU to PC connection and network configuration. Connections through a router may also cause conflicts. |
| Could not connect to the CPU.  | CPU is not able to be connected.  | Check CPU to PC connection.  |
| Could not disconnect the CPU.  | CPU is not able to be disconnected.   | Check CPU to PC connection.  |
| Could not connect to the selected CPU.                                     | Failed to validate security on connection.                                  | Check CPU to PC connection and required security passwords.  |
| Cannot blink CPU due to CPU error.   | CPU failed to blink CPU run light.  | Check CPU to PC connection and clear existing CPU errors.  |
| Cannot blink CPU due to network problem.                                   | CPU failed to respond to the blink request.                                 | Check CPU to PC connection and network configuration. Connections through a router may also cause conflicts. |
| Failed to retrieve I/O inventory from CPU '<CPU Name>'.                    | CPU failed to respond to the inventory request.                             | Check CPU to PC connection and request again.  |
| Failed to put the CPU to run mode.   | CPU is not able to be put in run mode.                                      | CPU mode switch must be in the Run position and errors cleared.  |
| Failed to put the CPU to stop mode.  | CPU is not able to be put in stop mode.                                     | Check CPU to PC connection.  |
| Failed to put the CPU to debug mode.                                       | CPU is not able to be put in debug mode.                                    | Check CPU to PC connection. CPU must be in STOP before entering debug mode.                                  |
| CPU has existing connection.   | CPU cannot be connected since it has already connected to another software. | Verify existing connections.   |
| Failed to put the CPU into <CPU Mode> mode because CPU connection is lost. | CPU connection is lost while setting CPU mode.                              | Check CPU to PC connection.  |

## Project Error Messages - Continued

| Error Message   | Cause  | Solution   |
|---|--|--|
| Failed to put the CPU into <CPU Mode> mode because CPU has existing critical error.                                     | Cannot set CPU mode due to critical errors on the CPU.   | Check CPU to PC connection and clear errors.   |
| Failed to put the CPU into run mode because the CPU switch is set to the STOP position.                                 | Cannot set CPU to run mode since the run/stop switch is in the stop position.  | Place the CPU switch in Run.   |
| Could not connect to the detected CPU.  | An unknown failure occurred on connection.   | Check CPU to PC connection.  |
| You do not have permission to access this feature.  | The security setup does not allow the current user to perform this operation.  | Check CPU to PC connection and required security passwords.  |
| You need to specify a user name.  | The name on a user account was deleted while editing the profile.  | Specify the user name.   |
| You need to specify a password.   | The password on a user account was deleted while editing the profile.  | Specify the password.  |
| The two passwords do not match.   | The password on a user account was changed and the verification does not match the new value.                                    | Re-enter the password and check to make sure both are the same.  |
| At least one user needs to have "Project Transfer From CPU and Monitor Data" selected to enable the protection feature. | Project Transfer from CPU and Data Monitor security was enabled without a user with these rights currently defined.              | Define at least one user with the appropriate project transfer rights.   |
| At least one user needs to have "Project Transfer To CPU" selected to enable the protection feature.                    | Project Transfer to CPU security was enabled without a user with these rights currently defined.                                 | Define at least one user with the appropriate project transfer rights.   |
| You must connect to a CPU first.  | User tried to Set Factory Defaults, Reboot the CPU, Read the SRAM, or Clear CPU Memory without first being connected to the CPU. | Check CPU to PC connection.  |
| The current project does not contain a CPU in the configuration. Go to: Setup>Hardware Config to correct the problem.   | The user tried to download a project that does not contain a CPU to the CPU or USB Pen Drive.                                    | Add a CPU to the hardware configuration or connect to the CPU and in the hardware configurations dialog select "read configuration". |
| The CPU firmware is in service mode. The requested action is not available in this mode.                                | The user tried to transfer a project to a CPU that is in Service Mode.   | Check CPU to PC connection and upgrade firmware.   |
| Please select a search result first.  | In the Find dialog, User pressed the GoTo button before selecting an entry in the Search Results list.                           | Define your search criteria and try again.   |
| Incorrect Key Code.   | User entered an invalid license keycode.   | Verify correct key code was entered. Pay close attention to capitalization, and mixture of letters and numbers.                      |

# SECURITY CONSIDERATIONS FOR CONTROL SYSTEMS NETWORKS

---



In This Appendix...

Security Considerations for Control Systems Networks ..... C-1

# Security Considerations for Control Systems Networks

Manufacturers are realizing that to stay competitive, their Automation and Control Systems need to be more integrated within their plant. The systems often need to be integrated with upstream Enterprise Data Systems, and even further integrated to allow information to be accessible across multiple plants, or even through the Internet. This convergence of the IT world with the Automation World creates challenges in maintaining secure systems and protecting your investments in processes, personnel, data and intellectual property.

While Automation Networks and Systems have built-in password protection schemes, this is only one very small step in securing your systems. Automation Control System Networks need to incorporate data protection and security measures that are at least as robust as a typical business computer system. We recommend that users of PLCs, HMI products and SCADA systems perform your own network security analysis to determine the proper level of security required for you application. However, the Department of Homeland Security's National Cybersecurity and Communications Integration Center (NCCIC) and Industrial Control Systems Cyber Emergency Response Team (ICS-CERT) has provided direction related to network security and safety under an approach described as "Defense in Depth", which is published at [https://ics-cert.uscert.gov/sites/default/files/recommended\\_practices/NCCIC\\_ICSCERT\\_Defense\\_in\\_Depth\\_2016\\_S508C.pdf](https://ics-cert.uscert.gov/sites/default/files/recommended_practices/NCCIC_ICSCERT_Defense_in_Depth_2016_S508C.pdf).

This comprehensive security strategy involves physical protection methods, as well as process and policy methods. This approach creates multiple layers and levels of security for industrial automation systems. Such safeguards include the location of control system networks behind firewalls, their isolation from business networks, the use of intrusion detection systems, and the use of secure methods for remote access such as Virtual Private Networks (VPNs). Further, users should minimize network exposure for all control system devices and such control systems and these systems should not directly face the internet. Following these procedures should significantly reduce your risks both from external sources as well as internal sources, and provide a more secure system.

It is the user's responsibility to protect such systems, just as you would protect your computer and business systems. AutomationDirect recommends using one or more of these resources in putting together a secure system:

- US-CERT's Control Systems Security Program at the following web address: [www.us-cert.gov/control\\_systems/](http://www.us-cert.gov/control_systems/)
- Special Publication 800-82 of the National Institute of Standards and Technology – Guide to Industrial Control Systems (ICS) Security <https://csrc.nist.gov/publications/detail/sp/800-82/rev-2/final>
- ISA99, Industrial Automation and Control Systems Security <http://www.isa.org/MSTemplate.cfm?MicrositeID=988&CommitteeID=6821>  
(please note this is a summary and these standards have to be purchased from ISA)

The above set of resources provides a comprehensive approach to securing a control system network and reducing risk and exposure from security breaches. Given the nature of any system that accesses the internet, it is incumbent upon each user to assess the needs and requirements of their application, and take steps to mitigate the particular security risks inherent in their control system.