

I/O WIRING AND SPECIFICATIONS



In This Chapter...

I/O Wiring Strategies	3-2
I/O Modules Position, Wiring, and Specification	3-13
Calculating the Power Budget	3-18
DL205 Digital Input Modules	3-22
DL205 Digital Output Modules	3-28
DL205 Analog Input Modules	3-44
DL205 RTD and Thermocouple Modules	3-52
DL205 Analog Output Modules	3-56
DL205 Combination Analog I/O Modules	3-72
Glossary of Specification Terms	3-78

I/O Wiring Strategies

The DL205 PLC system is very flexible and will work in many different wiring configurations. By studying this section before actual installation, you can probably find the best wiring strategy for your application. This will help to lower system cost, wiring errors, and avoid safety problems.

PLC Isolation Boundaries

PLC circuitry is divided into three main regions separated by isolation boundaries, shown in the drawing below. Electrical isolation provides safety, so that a fault in one area does not damage another. A powerline filter will provide isolation between the power source and the power supply. A transformer in the power supply provides magnetic isolation between the primary and secondary sides. Opto-couplers provide optical isolation in Input and Output circuits. This isolates logic circuitry from the field side, where factory machinery connects. Note the discrete inputs are isolated from the discrete outputs, because each is isolated from the logic side. Isolation boundaries protect the operator interface (and the operator) from power input faults or field wiring faults. When wiring a PLC, it is extremely important to avoid making external connections that connect logic side circuits to any other.

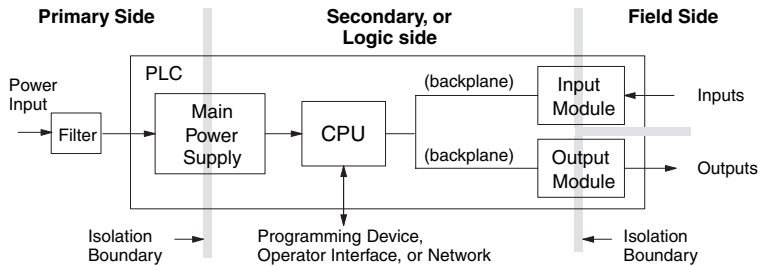

In addition to the basic circuits covered above, AC-powered and 125VDC bases include an auxiliary +24VDC power supply with its own isolation boundary. Since the supply output is isolated from the other three circuits, it can power input and/or output circuits!

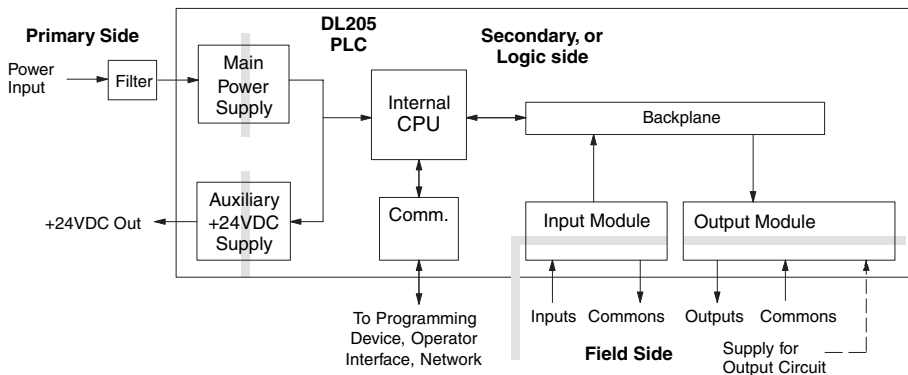

Powering I/O Circuits with the Auxiliary Supply

In some cases, using the built-in auxiliary +24VDC supply can result in a cost savings for your control system. It can power combined loads up to 300mA. Be careful not to exceed the current rating of the supply. If you are the system designer for your application, you may be able to select and design in field devices which can use the +24VDC auxiliary supply.

All AC powered and 125VDC DL205 bases feature the internal auxiliary supply. If input devices AND output loads need +24VDC power, the auxiliary supply may be able to power both circuits as shown in the following diagram.

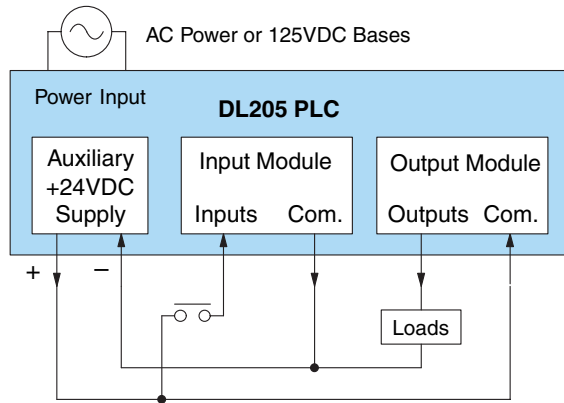

The 12/24VDC powered DL205 bases are designed for application environments in which low-voltage DC power is more readily available than AC. These include a wide range of battery-powered applications, such as remotely-located control, in vehicles, portable machines, etc. For this application type, all input devices and output loads typically use the same DC power source. Typical wiring for DC-powered applications is shown in the following diagram.

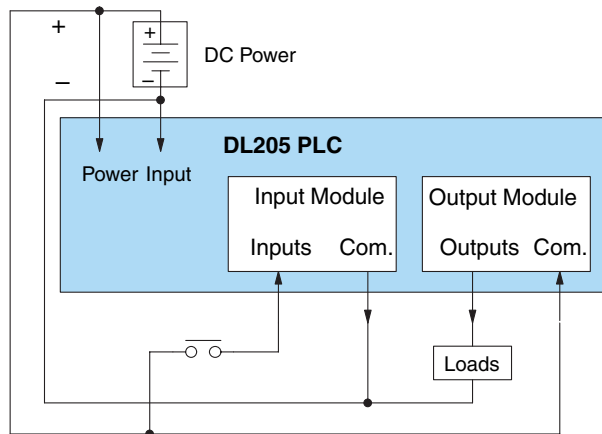

Powering I/O Circuits Using Separate Supplies

In most applications it will be necessary to power the input devices from one power source, and to power output loads from another source. Loads often require high-energy AC power, while input sensors use low-energy DC. If a machine operator is likely to come in close contact with input wiring, then safety reasons also require isolation from high-energy output circuits. It is most convenient if the loads can use the same power source as the PLC, and the input sensors can use the auxiliary supply, as shown to the left in the figure below.

If the loads cannot be powered from the PLC supply, then a separate supply must be used as shown to the right in the figure below.

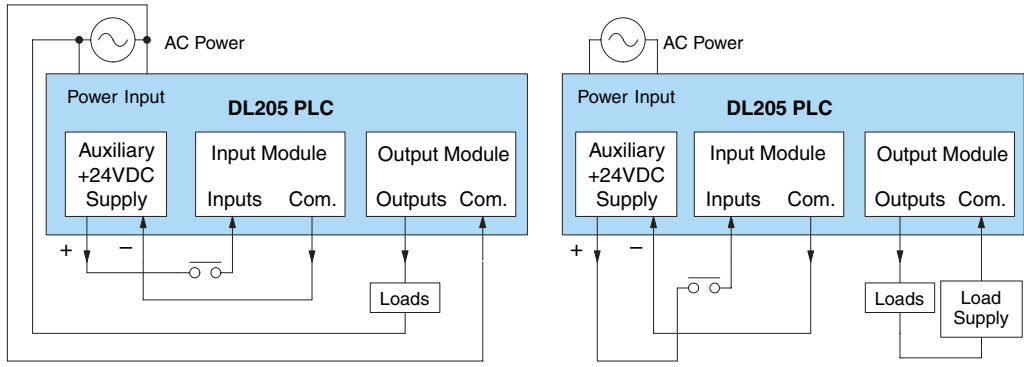

Some applications will use the PLC external power source to also power the input circuit. This typically occurs on DC-powered PLCs, as shown in the drawing below to the left. The inputs share the PLC power source supply, while the outputs have their own separate supply. A worst-case scenario, from a cost and complexity viewpoint, is an application which requires separate power sources for the PLC, input devices, and output loads. The wiring diagram example below on the right shows how this can work, but the auxiliary supply output is an unused resource. You will want to avoid this situation, if possible.

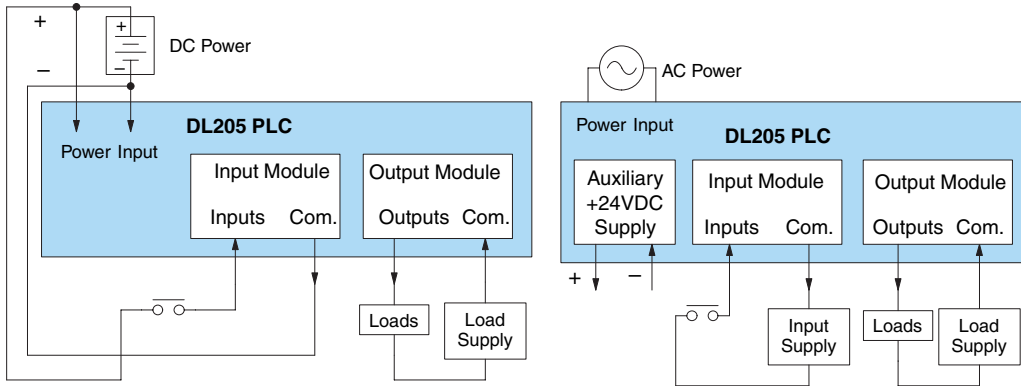

Sinking / Sourcing Concepts

Before going further in the study of wiring strategies, you must have a solid understanding of “sinking” and “sourcing” concepts. Use of these terms occurs frequently in input or output circuit discussions. It is the goal of this section to make these concepts easy to understand, further ensuring your success in installation. First the following short definitions are provided, followed by practical applications.

Sinking = provides a path to supply ground (-)

Sourcing = provides a path to supply source (+)

First you will notice these are only associated with DC circuits and not AC, because of the reference to (+) and (-) polarities. Therefore, sinking and sourcing terminology only applies to DC input and output circuits. Input and output points that are sinking only or sourcing only can conduct current in only one direction. This means it is possible to connect the external supply and field device to the I/O point with current trying to flow in the wrong direction, and the circuit will not operate. However, you can successfully connect the supply and field device every time by understanding “sourcing” and “sinking”.

For example, the figure to the right depicts a “sinking” input. To properly connect the external supply, you will have to connect it so the input provides a path to ground (-). Start at the PLC input terminal, follow through the input sensing circuit, exit at the common terminal, and connect the supply (-) to the common terminal. By adding the switch, between the supply (+) and the input, the circuit has been completed. Current flows in the direction of the arrow when the switch is closed.

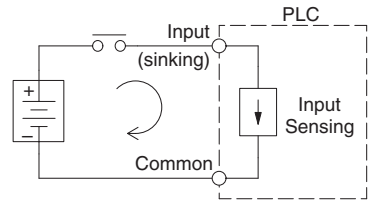

Apply the circuit principle above to the four possible combinations of input/output sinking/sourcing types as shown below. The I/O module specifications at the end of this chapter list the input or output type.

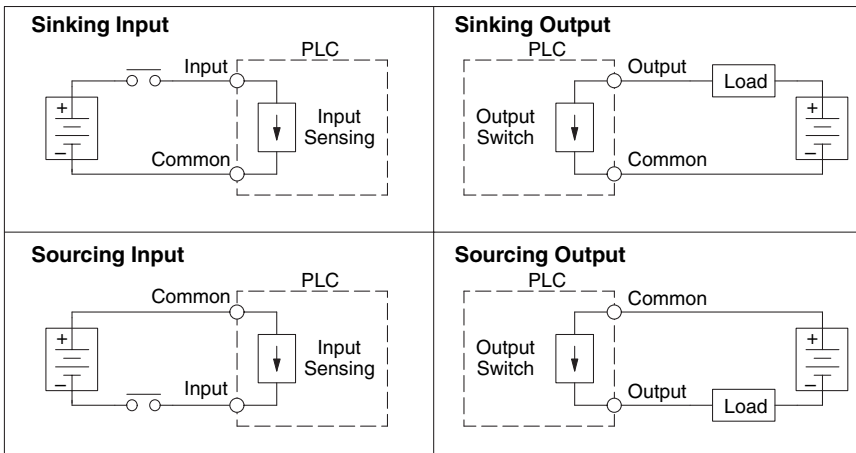

I/O “Common” Terminal Concepts

In order for a PLC I/O circuit to operate, current must enter at one terminal and exit at another. Therefore, at least two terminals are associated with every I/O point. In the figure to the right, the Input or Output terminal is the main path for the current. One additional terminal must provide the return path to the power supply.

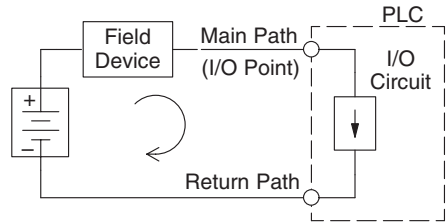

If there was unlimited space and budget for I/O terminals, every I/O point could have two dedicated terminals as the figure above shows. However, providing this level of flexibility is not practical or even necessary for most applications. So, most Input or Output points on PLCs are in groups which share the return path (called commons). The figure to the right shows a group (or bank) of four input points which share a common return path. In this way, the four inputs require only five terminals instead of eight.

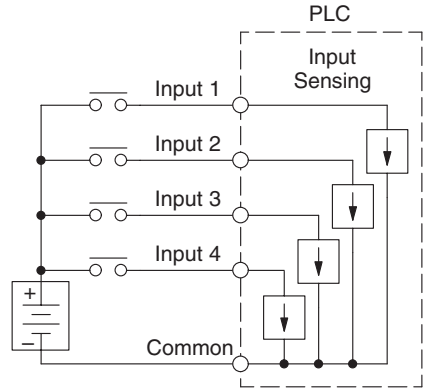

NOTE: In the circuit above, the current in the common path is 4 times any channel's input current when all inputs are energized. This is especially important in output circuits, where heavier gauge wire is sometimes necessary on commons.

Most DL205 input and output modules group their I/O points into banks that share a common return path. The best indication of I/O common grouping is on the wiring label, such as the one shown to the right. There are two circuit banks with eight input points in each. The common terminal for each is labeled “CA” and “CB”, respectively.

In the wiring label example, the positive terminal of a DC supply connects to the common terminals. Some symbols you will see on the wiring labels, and their meanings are:

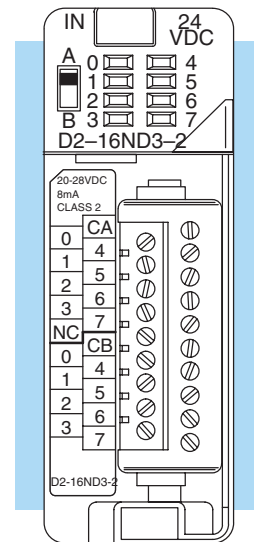
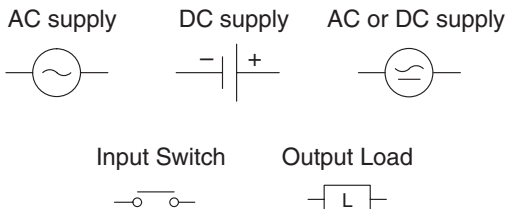

Connecting DC I/O to “Solid State” Field Devices

In the previous section on Sourcing and Sinking concepts, the DC I/O circuits were explained to sometimes only allow current to flow one way. This is also true for many of the field devices which have solid-state (transistor) interfaces. In other words, field devices can also be sourcing or sinking. *When connecting two devices in a series DC circuit, one must be wired as sourcing and the other as sinking.*

Solid State Input Sensors

Several DL205 DC input modules are flexible because they detect current flow in either direction, so they can be wired as either sourcing or sinking. In the following circuit, a field device has an open-collector NPN transistor output. It sinks current from the PLC input point, which sources current. The power supply can be the +24 auxiliary supply or another supply (+12VDC or +24VDC), as long as the input specifications are met.

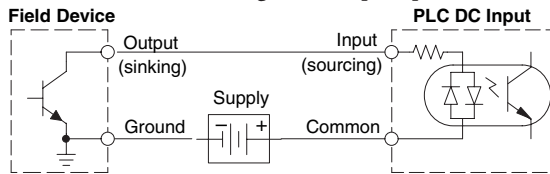

In the next circuit, a field device has an open-collector PNP transistor output. It sources current to the PLC input point, which sinks the current back to ground. Since the field device is sourcing current, no additional power supply is required.

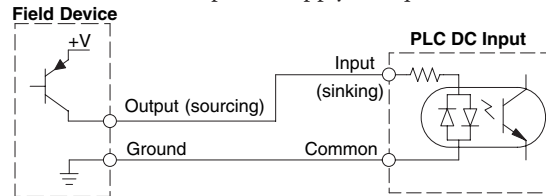

Solid State Output Loads

Sometimes an application requires connecting a PLC output point to a solid state input on a device. This type of connection is usually made to carry a low-level control signal, not to send DC power to an actuator.

Several of the DL205 DC output modules are the sinking type. This means that each DC output provides a path to ground when it is energized. In the following circuit, the PLC output point sinks current to the output common when energized. It is connected to a sourcing input of a field device input.

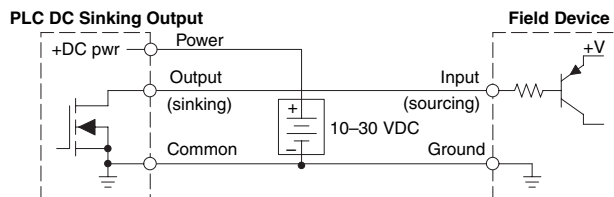

In the next example a PLC sinking DC output point is connected to the sinking input of a field device. This is a little tricky, because both the PLC output and field device input are sinking type. Since the circuit must have one sourcing and one sinking device, a sourcing capability needs to be added to the PLC output by using a pull-up resistor. In the circuit below, an $R_{\text{pull-up}}$ is connected from the output to the DC output circuit power input.

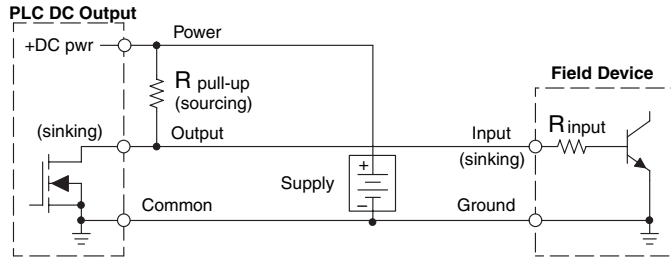

NOTE 1: DO NOT attempt to drive a heavy load (>25mA) with this pull-up method

NOTE 2: Using the pull-up resistor to implement a sourcing output has the effect of inverting the output point logic. In other words, the field device input is energized when the PLC output is OFF, from a ladder logic point of view. Your ladder program must comprehend this and generate an inverted output. Or, you may choose to cancel the effect of the inversion elsewhere, such as in the field device.

It is important to choose the correct value of $R_{\text{pull-up}}$. In order to do so, you need to know the nominal input current to the field device (I_{input}) when the input is energized. If this value is not known, it can be calculated as shown (a typical value is 15mA). Then use I_{input} and the voltage of the external supply to compute $R_{\text{pull-up}}$. Then calculate the power $P_{\text{pull-up}}$ (in watts), in order to size $R_{\text{pull-up}}$ properly.

$$I_{\text{input}} = \frac{V_{\text{input (turn-on)}}}{R_{\text{input}}}$$

$$R_{\text{pull-up}} = \frac{V_{\text{supply}} - 0.7}{I_{\text{input}}} - R_{\text{input}}$$

$$P_{\text{pull-up}} = \frac{V_{\text{supply}}^2}{R_{\text{pull-up}}}$$

Of course, the easiest way to drive a sinking input field device as shown below is to use a DC sourcing output module. The Darlington NPN stage will have about 1.5 V ON-state saturation, but this is not a problem with low-current solid-state loads.

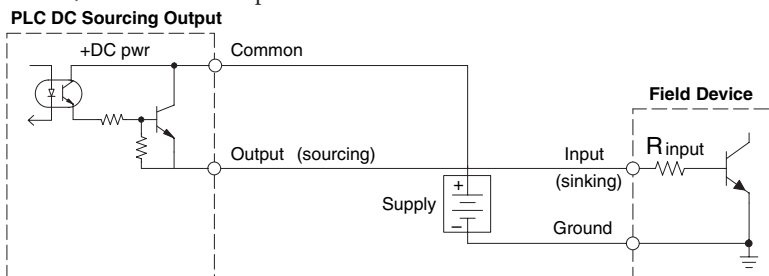

Relay Output Guidelines

Several output modules in the DL205 I/O family feature relay outputs: D2–04TRS, D2–08TR, D2–12TR, D2–08CDR, F2–08TR and F2–08TRS. Relays are best for the following applications:

- Loads that require higher currents than the solid-state outputs can deliver
- Cost-sensitive applications
- Some output channels need isolation from other outputs (such as when some loads require different voltages than other loads)

Some applications in which NOT to use relays:

- Loads that require currents under 10mA
- Loads which must be switched at high speed or heavy duty cycle

Relay outputs in the DL205 output modules are available in two contact arrangements, shown to the right. The Form A type, or SPST (single pole, single throw) type is normally open and is the simplest to use. The Form C type, or SPDT (single pole, double throw) type has a center contact which moves and a stationary contact on either side. This provides a normally closed contact and a normally open contact.

Some relay output modules relays share common terminals, which connect to the wiper contact in each relay of the bank. Other relay modules have relays which are completely isolated from each other. In all cases, the module drives the relay coil when the corresponding output point is on.

Relay with Form A contacts

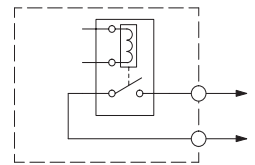

Relay with Form C contacts

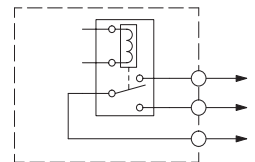

Surge Suppression For Inductive Loads



NOTE: For updated information on surge suppression for inductive loads, refer to Application Note AN-MISC-032 located on the Technical Support area of our website. The url is: <http://support.automationdirect.com/docs/an-misc-032.pdf>

Inductive load devices (devices with a coil) generate transient voltages when de-energized with a relay contact. When a relay contact is closed it, “bounces”, which energizes and de-energizes the coil until the “bouncing” stops. The transient voltages generated are much larger in amplitude than the supply voltage, especially with a DC supply voltage.

When switching a DC-supplied inductive load, the full supply voltage is always present when the relay contact opens (or “bounces”). When switching an AC-supplied inductive load, there are two (2) points when the voltage is zero (0) in one complete cycle of a sine wave; therefore, there are two (2) chances in 60 (60Hz) or 50 (50Hz) to stop the current flow at a zero crossover point. If current flow isn’t stopped, the relay contact will open (or “bounce”). If the voltage is not zero when the relay contact opens, there is energy stored in the inductor that is released when the voltage to the inductor is suddenly removed. This release of energy is the cause of the transient voltages.

When inductive load devices (motors, motor starters, interposing relays, solenoids, valves, etc.) are controlled with relay contacts, it is recommended that a surge suppression device be connected directly across the coil of the field device. If the inductive device has plug-type connectors, the suppression device can be installed on the terminal block of the relay output.

Transient Voltage Suppressors (TVS or transorb) provide the best surge and transient suppression of AC and DC powered coils, providing the fastest response with the smallest overshoot.

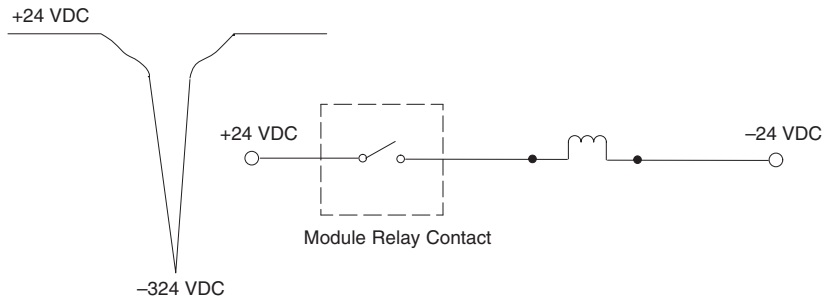

Metal Oxide Varistors (MOV) provide the next best surge and transient suppression of AC and DC powered coils.

For example, the waveform in the figure below shows the energy released when opening a contact switching a 24 VDC solenoid. Notice the large voltage spike.

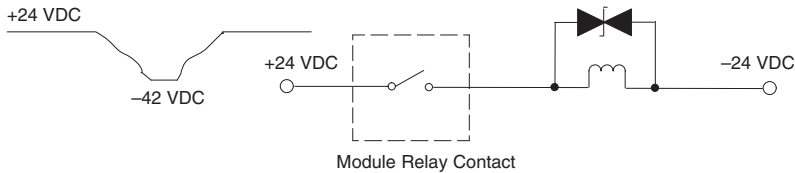

This figure shows the same circuit with a transorb (TVS) across the coil. Notice that the voltage spike is significantly reduced.

Use the following table to help select a TVS or MOV suppressor for your application based on the inductive load voltage.

Vendor / Catalog	Suppressor Types	Inductive Load Voltage	Part Number
AutomationDirect Transient Voltage Suppressors www.automationdirect.com	8-channel TVS	24 VDC	ZL-TD8-24
	8-channel TVS	110 VAC	ZL-TD8-120
General Instrument Transient Voltage Suppressors and LiteOn Diodes; from Digi-Key Catalog; www.digikey.com ; Phone: 1-800-344-4539	TVS, MOV TVS, MOV TVS Diode	110/120 VAC 220/240 VAC 12/24 VDC or VAC 12/24 VDC or VAC	Check Digi-Key Corp. catalog or website

Relay contacts wear according to the amount of relay switching, amount of spark created at the time of open or closure, and presence of airborne contaminants.

However, there are some steps you can take to help prolong the life of relay contacts:

- Switch the relay on or off only when the application requires it.
- If you have the option, switch the load on or off at a time when it will draw the least current.
- Take measures to suppress inductive voltage spikes from inductive DC loads such as contactors and solenoids (circuit given below).

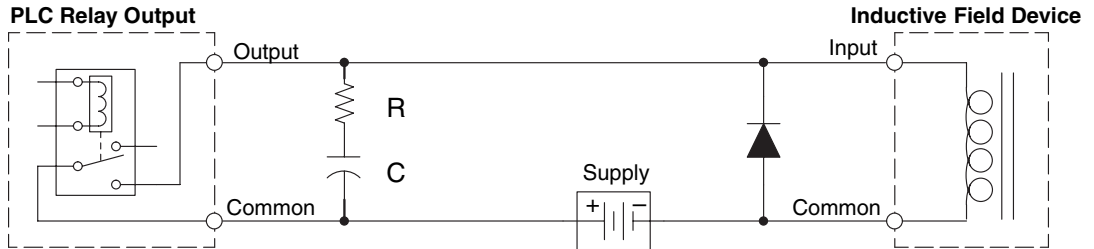

Adding external contact protection may extend relay life beyond the number of contact cycles listed in the specification tables for relay modules. High current inductive loads such as clutches, brakes, motors, direct-acting solenoid valves, and motor starters will benefit the most from external contact protection.

The RC network must be located close to the relay module output connector. To find the values for the RC snubber network, first determine the voltage across the contacts when open, and the current through them when closed. If the load supply is AC, then convert the current and voltage values to peak values:

Now you are ready to calculate values for R and C, according to the formulas:

$$C (\mu\text{F}) = \frac{I^2}{10} \qquad R (\Omega) = \frac{V}{10 \times I^x} \quad , \text{ where } x = 1 + \frac{50}{V}$$

C minimum = 0.001 μF , the voltage rating of C must be $\geq V$, non-polarized

R minimum = 0.5 Ω , 1/2 W, tolerance is $\pm 5\%$

For example, suppose a relay contact drives a load at 120VAC, 1/2 A. Since this example has an AC power source, first calculate the peak values:

$$I_{\text{peak}} = I_{\text{rms}} \times 1.414, = 0.5 \times 1.414 = 0.707 \text{ Amperes}$$

$$V_{\text{peak}} = V_{\text{rms}} \times 1.414 = 120 \times 1.414 = 169.7 \text{ Volts}$$

Now, find the values of R and C:

$$C (\mu\text{F}) = \frac{I^2}{10} = \frac{0.707^2}{10} = 0.05 \mu\text{F, voltage rating} \geq 170 \text{ Volts}$$

$$R (\Omega) = \frac{V}{10 \times I^x}, \text{ where } x = 1 + \frac{50}{V}$$

$$x = 1 + \frac{50}{169.7} = 1.29 \quad R (\Omega) = \frac{169.7}{10 \times 0.707^{1.29}} = 26 \Omega, 1/2 \text{ W, } \pm 5\%$$

If the contact is switching a DC inductive load, add a diode across the load as near to load coil as possible. When the load is energized, the diode is reverse-biased (high impedance). When the load is turned off, energy stored in its coil is released in the form of a negative-going voltage spike. At this moment, the diode is forward-biased (low impedance) and shunts the energy to ground. This protects the relay contacts from the high voltage arc that would occur as the contacts are opening.

For best results, follow these guidelines in using a noise suppression diode:

- DO NOT use this circuit with an AC power supply.
- Place the diode as close to the inductive field device as possible.
- Use a diode with a peak inverse voltage rating (PIV) at least 100 PIV, 3A forward current or larger. Use a fast-recovery type (such as Schottky type). DO NOT use a small-signal diode such as 1N914, 1N941, etc.
- Be sure the diode is in the circuit correctly before operation. If installed backwards, it short-circuits the supply when the relay energizes.

I/O Modules Position, Wiring, and Specification

Slot Numbering

The DL205 bases each provide different numbers of slots for use with the I/O modules. You may notice the bases refer to 3-slot, 4-slot, etc. One of the slots is dedicated to the CPU-slot controller, so you always have one less I/O slot. For example, there are five I/O slots with a 6-slot base. The I/O slots are numbered 0–4. The CPU slot always contains a PLC CPU or a CPU-slot controller and is not numbered.

Module Placement Restrictions

The following table lists the valid locations for all types of modules in a DL205 system.

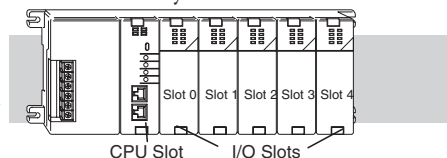

Module/Unit	Local CPU Base	Local Expansion Base	Remote I/O Base
CPUs	CPU Slot Only		
DC Input Modules	√	√	√
AC Input Modules	√	√	√
DC Output Modules	√	√	√
AC Output Modules	√	√	√
Relay Output Modules	√	√	√
Analog Input and Output Modules	√	√	√
Local Expansion			
Base Expansion Module	√	√	
Base Controller Module		CPU Slot Only	
Serial Remote I/O			
Remote Master	√		
Remote Slave Unit			CPU Slot Only
Ethernet Remote Master	√		
CPU Interface			
Ethernet Base Controller	Slot 0 Only		Slot 0 Only*
WinPLC	Slot 0 Only		
DeviceNet	Slot 0 Only		
PROFIBUS™	Slot 0 Only		
SDS	Slot 0 Only		
Specialty Modules			
Counter Interface	Slot 0 Only		
Counter I/O	√		√*
Data Communications	√		
Ethernet Communications	√		
BASIC CoProcessor	√		
Simulator	√	√	√
Filler	√	√	√

* When used with H2-ERM Ethernet Remote I/O system

Special Placement Considerations for Analog Modules

In most cases, the analog modules can be placed in any slot. However, the placement can also depend on the type of CPU you are using and the other types of modules installed to the left of the analog modules. If you're using a DL230 CPU (or a DL240 CPU with firmware earlier than V1.4), you should check the DL205 Analog I/O Manual for any possible placement restrictions related to your particular module. You can order the DL205 Analog I/O Manual by ordering part number D2-ANLG-M.

Discrete Input Module Status Indicators

The discrete modules provide LED status indicators to show the status of the input points.

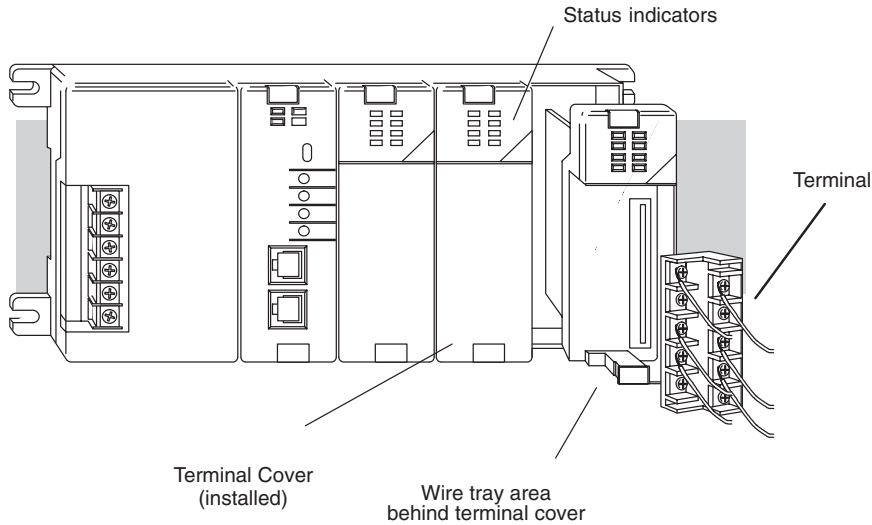

Color Coding of I/O Modules

The DL205 family of I/O modules have a color coding scheme to help you quickly identify if a module is either an input module, output module, or a specialty module. This is done through a color bar indicator located on the front of each module. The color scheme is listed below:

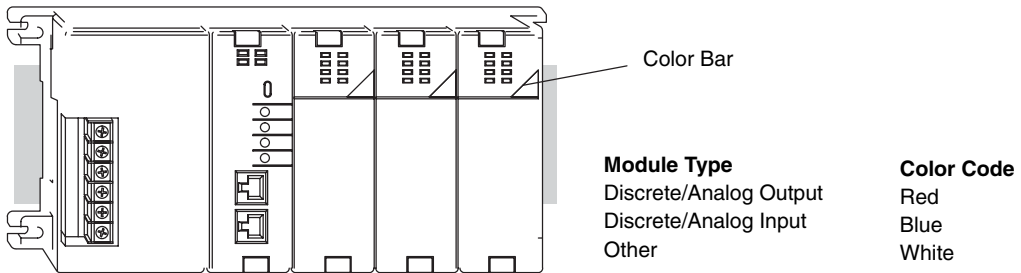

Wiring the Different Module Connectors

There are two types of module connectors for the DL205 I/O. Some modules have normal screw terminal connectors. Other modules have connectors with recessed screws. The recessed screws help minimize the risk of someone accidentally touching active wiring.

Both types of connectors can be easily removed. If you examine the connectors closely, you'll notice there are squeeze tabs on the top and bottom. To remove the terminal block, press the squeeze tabs and pull the terminal block away from the module.

We also have DIN rail mounted terminal blocks, DINnectors (refer to our catalog for a complete listing of all available products). ZIPLinks come with special pre-assembled cables with the I/O connectors installed and wired.



WARNING: For some modules, field device power may still be present on the terminal block even though the PLC system is turned off. To minimize the risk of electrical shock, check all field device power before you remove the connector.

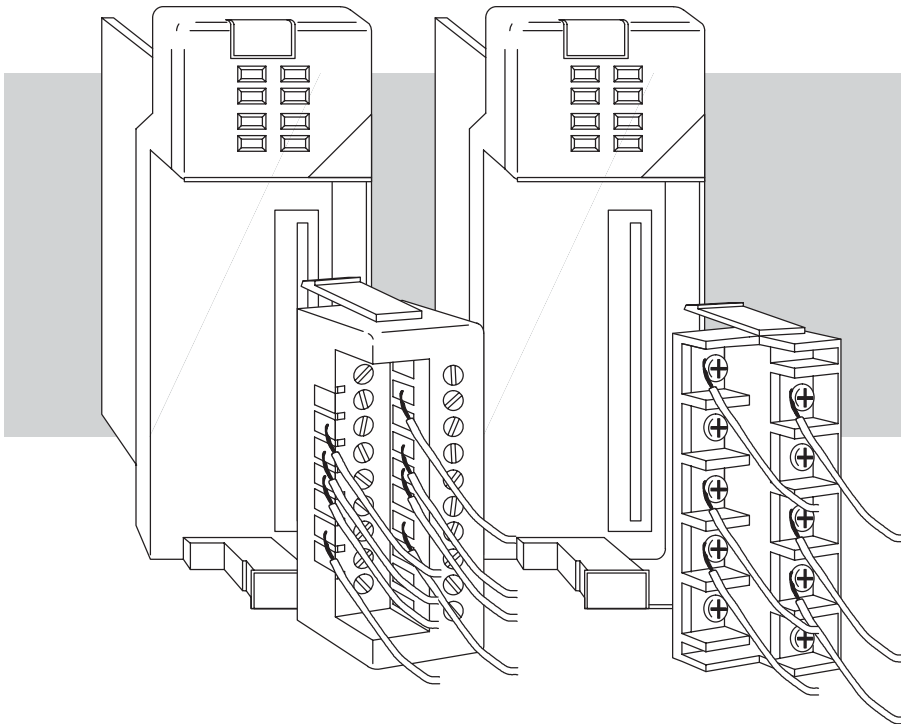

I/O Wiring Checklist

Use the following guidelines when wiring the I/O modules in your system.

1. There is a limit to the size of wire the modules can accept. The table below lists the suggested AWG for each module type. When making terminal connections, follow the suggested torque values.

Terminal type	Suggested AWG Range	Suggested Torque
10-Terminal Fixed	14 – 24 AWG	3.5 lb-inch (0.4 N-m)
10-Terminal Removable	16* – 24 AWG	7.81 lb-inch (0.88 N-m)
20-Terminal Removable	16* – 24 AWG	2.65 lb-in (0.3 N-m)



***NOTE: 16 AWG Type TFFN or Type MTW is recommended. Other types of 16 AWG may be acceptable, but it really depends on the thickness and stiffness of the wire insulation. If the insulation is too thick or stiff and a majority of the module's I/O points are used, then the plastic terminal cover may not close properly or the connector may pull away from the module. This applies especially for high temperature thermoplastics such as THHN.**

2. Always use a continuous length of wire; do not combine wires to attain a needed length.
3. Use the shortest possible wire length.
4. Use wire trays for routing where possible.
5. Avoid running wires near high energy wiring. Also, avoid running input wiring close to output wiring where possible.
6. To minimize voltage drops when wires must run a long distance, consider using multiple wires for the return line.
7. Avoid running DC wiring in close proximity to AC wiring where possible.
8. Avoid creating sharp bends in the wires.
9. To reduce the risk of having a module with a blown fuse, we suggest you add external fuses to your I/O wiring. A fast blow fuse, with a lower current rating than the I/O module fuse, can be added to each common or, a fuse with a rating of slightly less than the maximum current per output point can be added to each output. Refer to our catalog for a complete line of DINnectors, DIN rail mounted fuse blocks.

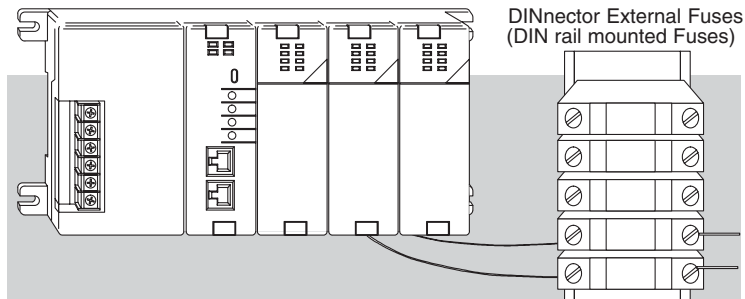

NOTE: For modules which have soldered or non-replaceable fuses, we recommend you return your module to us and let us replace your blown fuse(s) since disassembling the module will void your warranty.

I/O Points Required for Each Module

Each type of module requires a certain number of I/O points. This is also true for some specialty modules, such as analog, counter interface, etc..

DC Input Modules	Number of I/O Pts. Required	Specialty Modules, etc.	Number of I/O Pts. Required
D2-08ND3	8 Input	H2-ECOM(-F)	None
D2-16ND3-2	16 Input	D2-DCM	None
D2-32ND3(-2)	32 Input	H2-ERM(-F)	None
AC Input Modules		H2-EBC(-F)	None
D2-08NA-1	8 Input	D2-RMSM	None
D2-08NA-2	8 Input	D2-RSSS	None
D2-16NA	16 Input	F2-CP128	None
DC Output Modules		H2-CTRIO	None
D2-04TD1	8 Output (Only the first four points are used)	D2-CTRINT	8 Input 8 Output
D2-08TD1	8 Output	F2-DEVNETS-1	None
D2-16TD1-2 (2-2)	16 Output	H2-PBC	None
D2-16TD1(2)P	16 Output	F2-SDS-1	None
D2-32TD1(-2)	32 Output	D2-08SIM	8 Input
AC Output Modules		D2-EM	None
D2-08TA	8 Output	D2-CM	None
F2-08TA	8 Output	H2-ECOM(100)	None
D2-12TA	16 Output (See note 1)		
Relay Output Modules			
D2-04TRS	8 Output (Only the first four points are used)		
D2-08TR	8 Output		
F2-08TRS	8 Output		
F2-08TR	8 Output		
D2-12TR	16 Output (See note 1)		
Combination Modules			
D2-08CDR	8 In, 8 Out (Only the first four points are used for each type)		
Analog Modules			
F2-04AD-1 & 1L	16 Input		
F2-04AD-2 & 2L	16 Input		
F2-08AD-1	16 Input		
F2-02DA-1 & 1L	16 Output		
F2-02DA-2 & 2L	16 Output		
F2-08DA-1	16 Output		
F2-08DA-2	16 Output		
F2-02DAS-1	32 Output		
F2-02DAS-2	32 Output		
F2-4AD2DA	16 Input & 16 Output		
F2-8AD4DA-1	32 Input & 32 Output		
F2-8AD4DA-2	32 Input & 32 Output		
F2-04RTD	32 Input		
F2-04THM	32 Input		



NOTE 1: -12pt. modules consume 16 points. The first 6 points are assigned, two are skipped, and then the next 6 points are assigned. For example, a D2-12TA installed in slot 0 would use Y0-Y5, and Y-10-Y15. Y6-Y7 and Y16-Y17 would be unused.

Calculating the Power Budget

Managing your Power Resource

When you determine the types and quantity of I/O modules you will be using in the DL205 system it is important to remember there is a limited amount of power available from the power supply. We have provided a chart to help you easily see the amount of power available with each base. The following chart will help you calculate the amount of power you need with your I/O selections. At the end of this section you will also find an example of power budgeting and a worksheet for your own calculations.

If the I/O you choose exceeds the maximum power available from the power supply, you may need to use local expansion bases or remote I/O bases.



WARNING: It is extremely important to calculate the power budget. If you exceed the power budget, the system may operate in an unpredictable manner which may result in a risk of personal injury or equipment damage.

Bases	5V Current Supplied	Auxiliary 24VDC Current Supplied
D2-03B-1	2600 mA	300 mA
D2-04B-1	2600 mA	300 mA
D2-06B-1	2600 mA	300 mA
D2-09B-1	2600 mA	300 mA
D2-03BDC1-1	2600 mA	None
D2-04BDC1-1	2600 mA	None
D2-06BDC1-1	2600 mA	None
D2-09BDC1-1	2600 mA	None
D2-06BDC2-1	2600 mA	300 mA
D2-09BDC2-1	2600 mA	300 mA

CPU Power Specifications

The following chart shows the amount of current available for the two voltages supplied from the DL205 base. Use these currents when calculating the power budget for your system. The Auxiliary 24V Power Source mentioned in the table is a connection at the base terminal strip allowing you to connect to devices or DL205 modules that require 24VDC.

Module Power Requirements

Use the power requirements shown on the next page to calculate the power budget for your system. If an External 24VDC power supply is required, the external 24VDC from the base power supply may be used as long as the power budget is not exceeded.

Power Consumed			Power Consumed		
Device	5V (mA)	24V Auxilliary (mA)	Device	5V (mA)	24V Auxilliary (mA)
CPUs			Combination Modules		
D2-230	120	0	D2-08CDR	200	0
D2-240	120	0	Specialty Modules		
D2-250-1	330	0	H2-PBC	530	0
D2-260/262	330	0	H2-ECOM	450	0
DC Input Modules			H2-ECOM100	300	0
D2-08ND3	50	0	H2-ECOM-F	640	0
D2-16ND3-2	100	0	H2-ERM	320	0
D2-32ND3(-2)	25	0	H2-ERM-F	450	0
AC Input Modules			H2-EBC	320	0
D2-08NA-1	50	0	H2-EBC-F	450	0
D2-08NA-2	100	0	H2-CTRIO	400	0
D2-16NA	100	0	D2-DCM	300	0
DC Output Modules			D2-RMSM	200	0
D2-04TD1	60	20	D2-RSSS	150	0
D2-08TD1(-2)	100	0	D2-CTRINT	50*	0
D2-16TD1-2	200	80	D2-08SIM	50	0
D2-16TD2-2	200	0	D2-CM	100	0
D2-32TD1(-2)	350	0	D2-EM	130	0
AC Output Modules			F2-CP128	235	0
D2-08TA	250	0	F2-DEVNETS-1	160	0
F2-08TA	250	0	F2-SDS-1	160	0
D2-12TA	350	0			
Relay Output Modules					
D2-04TRS	250	0			
D2-08TR	250	0			
F2-08TRS	670	0			
F2-08TR	670	0			
D2-12TR	450	0			
Analog Modules					
F2-04AD-1	50	80	F2-02DAS-1	100	50mA per channel
F2-04AD-1L	100	5mA @ 10-30V	F2-02DAS-2	100	60mA per channel
F2-04AD-2	110	5mA @ 10-30V	F2-4AD2DA	90	80mA**
F2-04AD-2L	60	90mA @ 12V**	F2-8AD4DA-1	35	100
F2-08AD-1	100	5mA @ 10-30V	F2-8AD4DA-2	35	80
F2-08AD-2	100	5mA @ 10-30V	F2-04RTD	90	0
F2-02DA-1	40	60**	F2-04THM	110	60
F2-02DA-1L	40	70mA @ 12V**			
F2-02DA-2	40	60			
F2-02DA-2L	40	70mA @ 12V**			
F2-08DA-1	30	50mA**			
F2-08DA-2	60	140			

*requires external 5VDC for outputs

**add an additional 20mA per loop

Power Budget Calculation Example

The following example shows how to calculate the power budget for the DL205 system.

Base # 0	Module Type	5 VDC (mA)	Auxiliary Power Source 24VDC Output (mA)
Available Base Power	D2-09B-1	2600	300
CPU Slot	D2-260	+ 330	
Slot 0	D2-16ND3-2	+ 100	+ 0
Slot 1	D2-16NA	+ 100	+ 0
Slot 2	D2-16NA	+ 100	+ 0
Slot 3	F2-04AD-1	+ 50	+ 80
Slot 4	F2-02DA-1	+ 40	+ 60
Slot 5	D2-08TA	+ 250	+ 0
Slot 6	D2-08TD1	+ 100	+ 0
Slot 7	D2-08TR	+ 250	+ 0
Other			
Handheld Programmer	D2-HPP	+ 200	+ 0
Total Power Required		1520	140
Remaining Power Available		2600-1520 = 1080	300 - 140 = 160

1. Use the power budget table to fill in the power requirements for all the system components. First, enter the amount of power supplied by the base. Next, list the requirements for the CPU, any I/O modules, and any other devices, such as the Handheld Programmer, C-more HMI or the DV-1000 operator interface. Remember, even though the Handheld or the DV-1000 are not installed in the base, they still obtain their power from the system. Also, make sure you obtain any external power requirements, such as the 24VDC power required by the analog modules.
2. Add the current columns starting with CPU slot and put the total in the row labeled "Total power required"
3. Subtract the row labeled "Total power required" from the row labeled "Available Base Power". Place the difference in the row labeled "Remaining Power Available".
4. If "Total Power Required" is greater than the power available from the base, the power budget will be exceeded. It will be unsafe to use this configuration and you will need to restructure your I/O configuration.



WARNING: It is extremely important to calculate the power budget. If you exceed the power budget, the system may operate in an unpredictable manner which may result in a risk of personal injury or equipment damage.

Power Budget Calculation Worksheet

This blank chart is provided for you to copy and use in your power budget calculations.

Base # 0	Module Type	5VDC (mA)	Auxiliary Power Source 24VDC Output (mA)
Available Base Power			
CPU Slot			
Slot 0			
Slot 1			
Slot 2			
Slot 3			
Slot 4			
Slot 5			
Slot 6			
Slot 7			
Other			
Total Power Required			
Remaining Power Available			

1. Use the power budget table to fill in the power requirements for all the system components. This includes the CPU, any I/O modules, and any other devices, such as the Handheld Programmer, C-more HMI or the DV-1000 operator interface. Also, make sure you obtain any external power requirements, such as the 24VDC power required by the analog modules.
2. Add the current columns starting with CPU slot and put the total in the row labeled "Total power required".
3. Subtract the row labeled "Total power required" from the row labeled "Available Base Power". Place the difference in the row labeled "Remaining Power Available".
4. If "Total Power Required" is greater than the power available from the base, the power budget will be exceeded. It will be unsafe to use this configuration and you will need to restructure your I/O configuration.



WARNING: It is extremely important to calculate the power budget. If you exceed the power budget, the system may operate in an unpredictable manner which may result in a risk of personal injury or equipment damage.

DL205 Digital Input Modules

D2-08ND3, DC Input

Inputs per Module	8 (sink/source)
Commons per Module	1 (2 I/O terminal points)
Input Voltage Range	10.2-26.4 VDC
Peak Voltage	26.4 VDC
ON Voltage Level	9.5 VDC minimum
OFF Voltage Level	3.5 VDC maximum
AC Frequency	N/A
Input Impedance	2.7 kΩ
Input Current	4.0 mA @ 12VDC 8.5 mA @ 24VDC
Minimum ON Current	3.5 mA
Maximum OFF Current	1.5 mA
Base Power Required 5VDC	50mA
OFF to ON Response	1 to 8 ms
ON to OFF Response	1 to 8 ms
Terminal Type (included)	Removable, D2-8IOCON
Status Indicator	Logic side
Weight	2.3 oz. (65g)

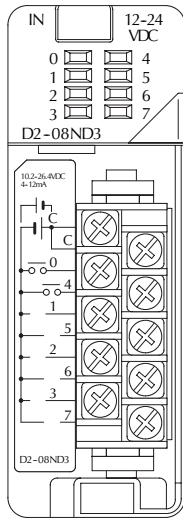
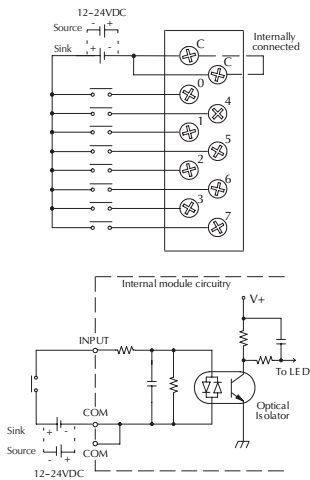
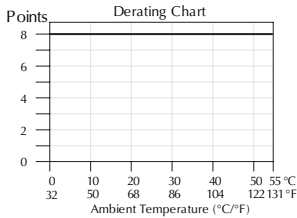

D2-16ND3-2, DC Input

Inputs per Module	16 (sink/source)
Commons per Module	2 isolated (8 I/O terminal points/com)
Input Voltage Range	20-28 VDC
Peak Voltage	30VDC (10mA)
ON Voltage Level	19VDC minimum
OFF Voltage Level	7VDC maximum
AC Frequency	N/A
Input Impedance	3.9 kΩ
Input Current	6mA @ 24VDC
Minimum ON Current	3.5 mA
Maximum OFF Current	1.5 mA
Base Power Required 5VDC	100mA
OFF to ON Response	3 to 9 ms
ON to OFF Response	3 to 9 ms
Terminal Type (included)	Removable, D2-16IOCON
Status Indicator	Logic side
Weight	2.3 oz. (65g)

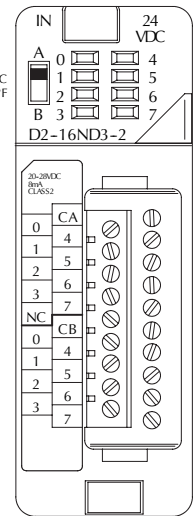
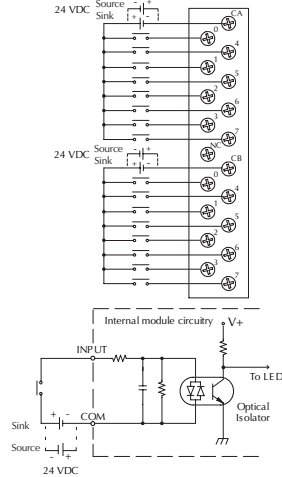
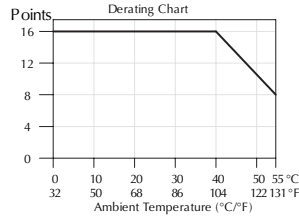

D2-32ND3, DC Input

Inputs per Module	32 (sink/source)
Commons per Module	4 isolated (8 I/O terminal points / com)
Input Voltage Range	20-28 VDC
Peak Voltage	30VDC
ON Voltage Level	19VDC minimum
OFF Voltage Level	7VDC maximum
AC Frequency	N/A
Input Impedance	4.8 kΩ
Input Current	8.0 mA @ 24 VDC
Minimum ON Current	3.5 mA
Maximum OFF Current	1.5 mA
Base Power Required 5VDC	25mA
OFF to ON Response	3 to 9 ms
ON to OFF Response	3 to 9 ms
Terminal Type (not included)	Removable 40-pin Connector ¹
Status Indicator	Module Activity LED
Weight	2.1 oz. (60g)

¹ Connector sold separately. See Terminal Blocks and Wiring for wiring options.

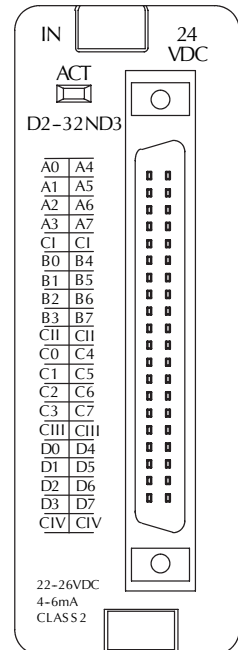
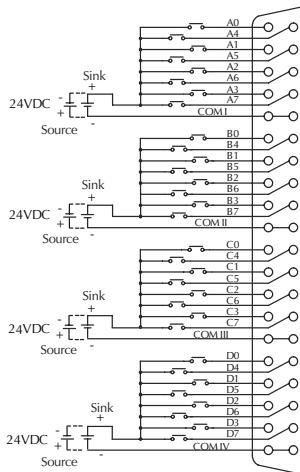
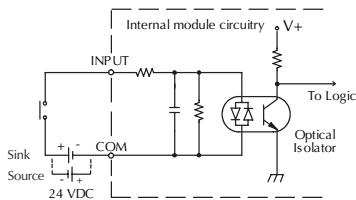
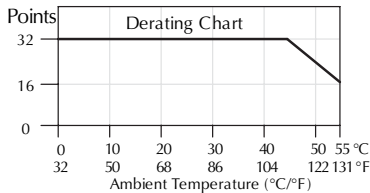

D2-32ND3-2, DC Input

Inputs per Module	32 (Sink/Source)
Commons per Module	4 isolated (8 I/O terminal points / com)
Input Voltage Range	4.50 to 15.6 VDC min. to max.
Peak Voltage	16VDC
ON Voltage Level	4VDC minimum
OFF Voltage Level	2VDC maximum
AC Frequency	N/A
Input Impedance	1.0 kΩ @ 5-15 VDC
Input Current	4mA @ 5VDC 11mA @ 12VDC 14mA @ 15VDC
Maximum Input Current	16mA @ 15.6 VDC
Minimum ON Current	3mA
Maximum OFF Current	0.5 mA
Base Power Required 5VDC	25mA
OFF to ON Response	3 to 9 ms
ON to OFF Response	3 to 9 ms
Terminal Type (not included)	Removable 40-pin connector ¹
Status Indicator	Module activity LED
Weight	2.1 oz (60g)
¹ Connector sold separately. See Terminal Blocks and Wiring for wiring options.	

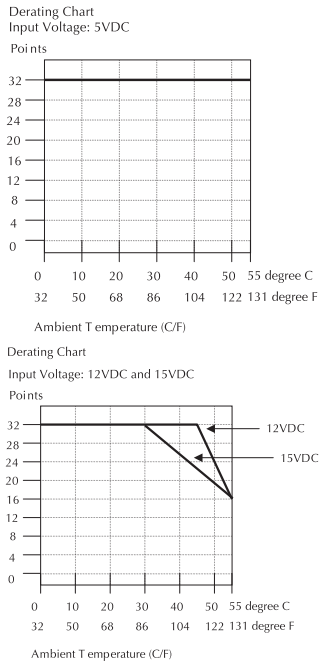
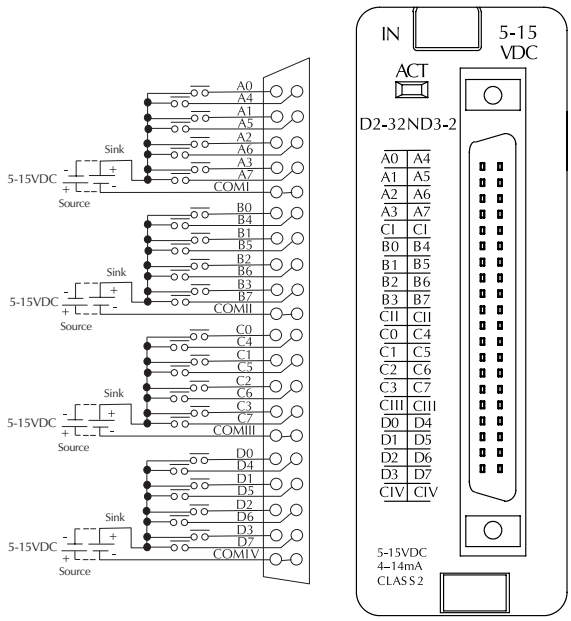

D2-08NA-1, AC Input

Inputs per Module	8
Commons per Module	1 (2 I/O terminal points)
Input Voltage Range	80-132 VAC
Peak Voltage	132VAC
ON Voltage Level	75VAC minimum
OFF Voltage Level	20VAC maximum
AC Frequency	47-63 Hz
Input Impedance	12k Ω @ 60Hz
Input Current	13mA @ 100VAC, 60Hz 11mA @ 100VAC, 50Hz
Minimum ON Current	5mA
Maximum OFF Current	2mA
Base Power Required 5VDC	50mA
OFF to ON Response	5 to 30 ms
ON to OFF Response	10 to 50 ms
Terminal Type (included)	Removable; D2-8IOCON
Status Indicator	Logic side
Weight	2.5 oz. (70g)

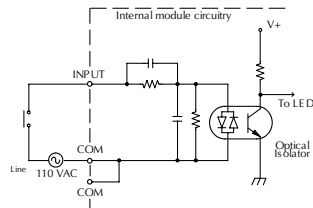
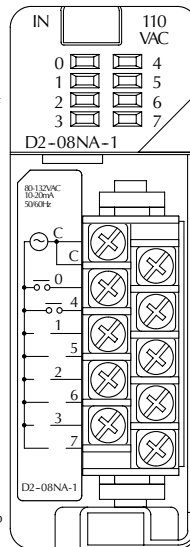
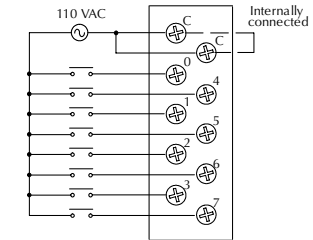
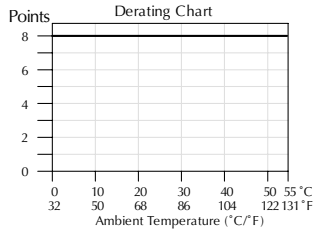

D2-08NA-2, AC Input

Inputs per Module	8
Commons per Module	1 (2 I/O terminal points)
Input Voltage Range	170-265 VAC
Peak Voltage	265VAC
ON Voltage Level	150VAC minimum
OFF Voltage Level	40VAC maximum
AC Frequency	47-63 Hz
Input Impedance	18k Ω @ 60Hz
Input Current	9mA @ 220VAC, 50Hz 11mA @ 265VAC, 50Hz 10mA @ 220VAC, 60Hz 12mA @ 265VAC, 60Hz
Minimum ON Current	10mA
Maximum OFF Current	2mA
Base Power Required 5VDC	100mA
OFF to ON Response	5 to 30ms
ON to OFF Response	10 to 50ms
Terminal Type (included)	Removably; D2-8IOCON
Status Indicator	Logic side
Weight	2.5 oz. (70g)

Operating Temperature	32°F to 131°F (0° to 55°C)
Storage Temperature	-4°F to 158°F (-20°C to 70°C)
Humidity	35% to 95% (non-condensing)
Atmosphere	No corrosive gases permitted
Vibration	MIL STD 810C 514.2
Shock	MIL STD 810C 516.2
Insulation Withstand Voltage	1500VAC 1 minute (COM-GND)
	10M \approx @ 500VDC
Noise Immunity	NEMA 1500V 1 minute SANKI 1000V 1 minute
RFI	150MHz, 430MHz

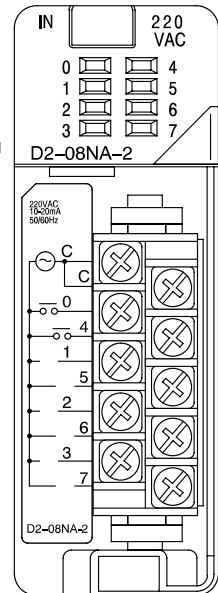
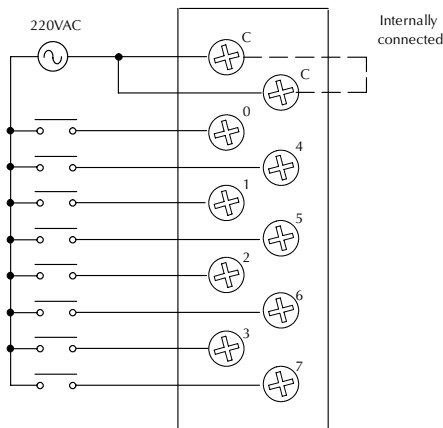
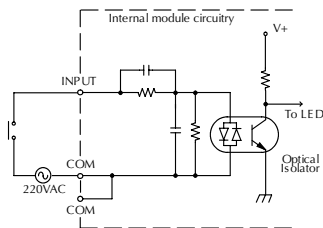
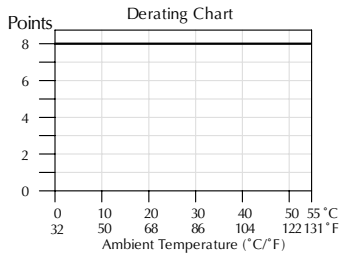

D2-16NA, AC Input

Inputs per Module	16
Commons per Module	2 (isolated)
Input Voltage Range	80-132 VAC
Peak Voltage	132VAC
ON Voltage Level	70VAC minimum
OFF Voltage Level	20VAC maximum
AC Frequency	47-63 Hz
Input Impedance	12kΩ @ 60Hz
Input Current	11mA @ 100VAC, 50Hz
	13mA @ 100VAC, 60Hz
	15mA @ 132VAC, 60Hz
Minimum ON Current	5mA
Maximum OFF Current	2mA
Base Power Required 5VDC	100mA
OFF to ON Response	5 to 30 ms
ON to OFF Response	10 to 50 ms
Terminal Type (included)	Removable; D2-16IOCON
Status Indicator	Logic side
Weight	2.4 oz. (68g)

F2-08SIM, Input Simulator

Inputs per Module	8
Base Power Required 5VDC	50mA
Terminal Type	None
Status Indicator	Switch side
Weight	2.65 oz. (75g)

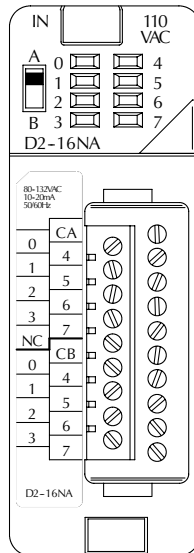
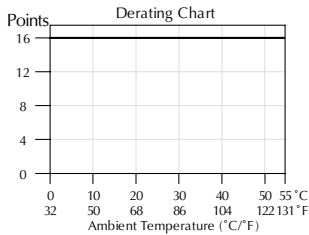
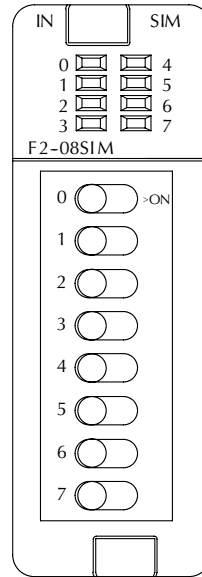

DL205 Digital Output Modules

D2-04TD1, DC Output

Outputs per Module	4 (current sinking)
Output Points Consumed	8 points (only first 4 pts. used)
Commons per Module	1 (4 I/O terminal points)
Output Type	NMOS FET (open drain)
Operating Voltage	10.2-26.4 VDC
Peak Voltage	40VDC
ON Voltage Drop	0.72 VDC maximum
AC Frequency	N/A
Max Load Current (resistive)	4A/point 8A/common
Max Leakage Current	0.1 mA @ 40VDC
Max Inrush Current	6A for 100ms, 15A for 10ms
Minimum Load Current	50mA

External DC Required	24VDC @ 20mA max.
Base Power Required 5VDC	60mA
OFF to ON Response	1ms
ON to OFF Response	1ms
Terminal Type (included)	Removable; D2-8IOCON
Status Indicator	Logic side
Weight	2.8 oz. (80g)
Fuses	4 (1 per point) (6.3 A slow blow, non-replaceable)

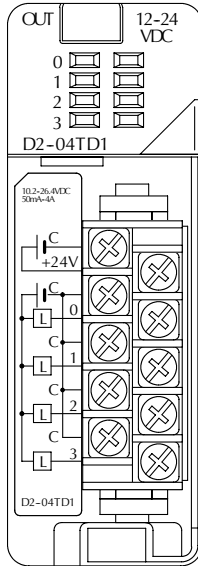
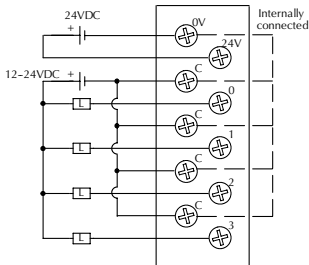
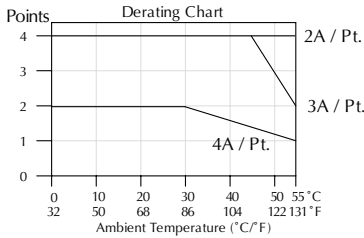

Inductive Load
Maximum Number of Switching Cycles per Minute

Load Current	Duration of output in ON state		
	7ms	40ms	100ms
0.1A	8000	1400	600
0.5A	1600	300	120
1.0A	800	140	60
1.5A	540	90	35
2.0A	400	70	-
3.0A	270	-	-
4.0A	200	-	-

At 40ms duration, loads of 3.0 A or greater cannot be used.

At 100ms duration, loads of 2.0 A or greater cannot be used.

Find the load current you expect to use and the duration that the output is ON. The number at the intersection of the row and column represents the switching cycles per minute. For example, a 1A inductive load that is on for 100 ms can be switched on and off a maximum of 60 times per minute. To convert this to duty cycle percentage use: (duration x cycles)/60. In this example, (60 x 0.1)/60 = 0.1, or 10% duty cycle.

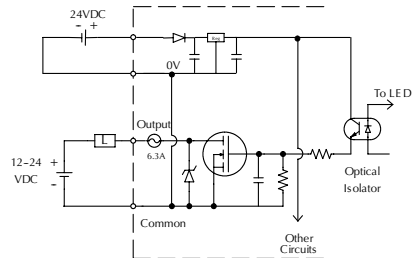

D2-08TD1, DC Output

Outputs per Module	8 (current sinking)
Commons per Module	1 (2 I/O terminal points)
Output Type	NPN open collector
Operating Voltage	10.2-26.4 VDC
Peak Voltage	40VDC
ON Voltage Drop	1.5 VDC maximum
AC Frequency	N/A
Minimum Load Current	0.5 mA
Max Load Current	0.3 A/point; 2.4 A/common
Max Leakage Current	0.1 mA @ 40VDC
Max Inrush Current	1A for 10ms
Base Power Required 5VDC	100mA
OFF to ON Response	1 ms
ON to OFF Response	1 ms
Terminal Type (included)	Removable; D2-8IOCON
Status Indicator	Logic side
Weight	2.3 oz. (65g)
Fuses	1 per common 5A fast blow, non-replaceable

D2-08TD2, DC Output

Outputs per Module	8 (current sourcing)
Commons per Module	1
Output Type	PNP open collector
Operating Voltage	12 to 24 VDC
Output Voltage	10.8 to 26.4 VDC
Peak Voltage	40VDC
ON Voltage Drop	1.5 VDC
AC Frequency	N/A
Minimum Load Current	N/A
Max Load Current	0.3 A per point; 2.4 A per common
Max Leakage Current	1.0 mA @ 40VDC
Max Inrush Current	1A for 10ms
Base Power Required 5VDC	100mA
OFF to ON Response	1ms
ON to OFF Response	1ms
Terminal Type (included)	Removable; D2-8IOCON
Status Indicator	Logic side
Weight	2.1 oz. (60g)
Fuses	1 per common 5A fast blow, non-replaceable

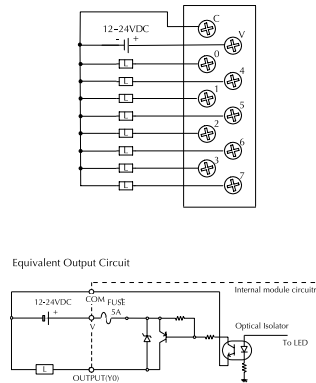
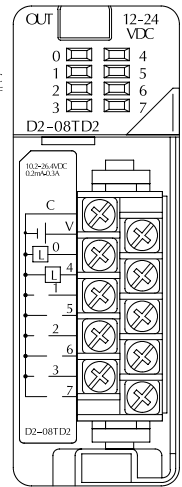
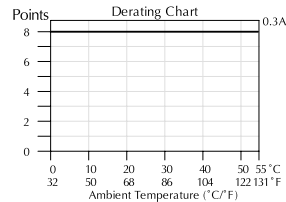
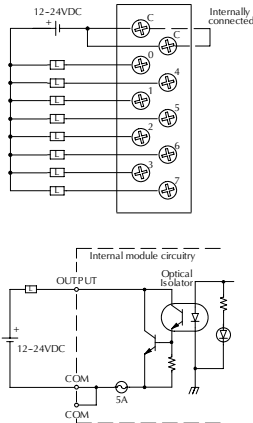
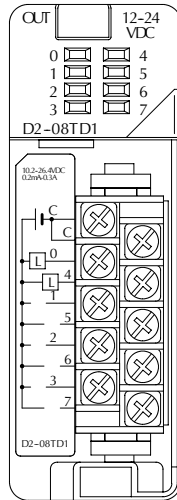
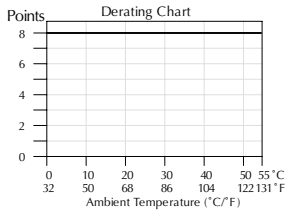

D2-16TD1-2, DC Output

Outputs per Module	16 (current sinking)
Commons per Module	1 (2 I/O terminal points)
Output Type	NPN open collector
External DC required	24VDC \pm 4V @ 80mA max
Operating Voltage	10.2-26.4 VDC
Peak Voltage	30VDC
ON Voltage Drop	0.5 VDC maximum
AC Frequency	N/A
Minimum Load Current	0.2 mA
Max Load Current	0.1A/point 1.6 A/common
Max Leakage Current	0.1 mA @ 30VDC
Max Inrush Current	150mA for 10ms
Base Power Required 5VDC	200mA
OFF to ON Response	0.5 ms
ON to OFF Response	0.5 ms
Terminal Type (included)	Removable; D2-16IOCON
Status Indicator	Logic side
Weight	2.3 oz. (65g)
Fuses	None

D2-16TD2-2, DC Output

Outputs per Module	16 (current sourcing)
Commons per Module	2
Output Type	NPN open collector
Operating Voltage	10.2-26.4 VDC
Peak Voltage	30 VDC
ON Voltage Drop	1.0 VDC maximum
AC Frequency	N/A
Minimum Load Current	0.2 mA
Max Load Current	0.1A/point 1.6A/module
Max Leakage Current	0.1 mA @ 30 VDC
Max Inrush Current	150 mA for 10 ms
Base Power Required 5VDC	200 mA
OFF to ON Response	0.5 ms
ON to OFF Response	0.5 ms
Terminal Type (included)	Removable; D2-16IOCON
Status Indicator	Logic side
Weight	2.8 oz. (80g)
Fuses	None

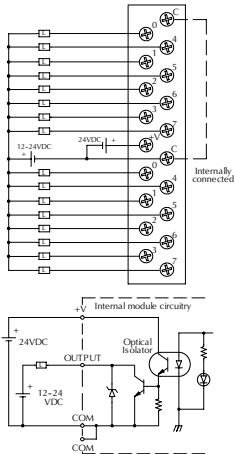
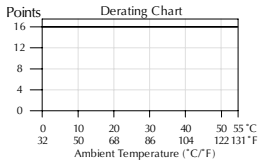

* Can also be used with 5VDC supply

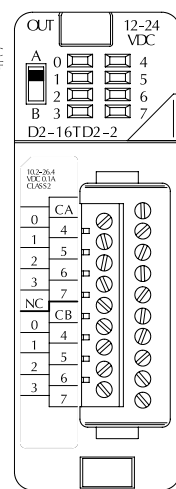
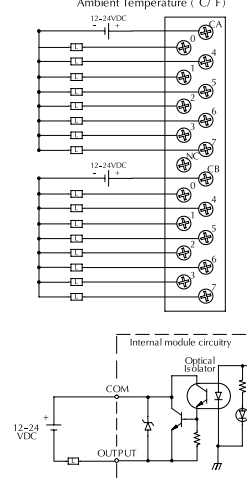
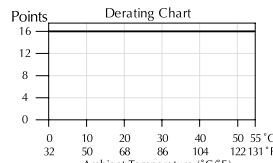
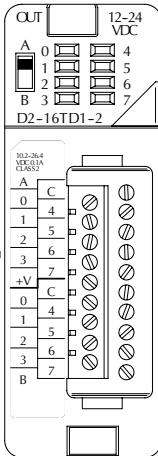

F2-16TD1(2)P, DC Output With Fault Protection



NOTE: Not supported in D2-230, D2-240 and D2-250 CPUs.

These modules detect the following fault status and turn the related X bit(s) on.

1. Missing external 24VDC for the module
2. Open load¹
3. Over temperature (the output is shut down)
4. Over load current (the output is shut down)

Fault Status	X bit Fault Status Indication
Missing external 24VDC	All 16 X bits are on.
Open load ¹	Only the X bit assigned to the faulted output is on
Over temperature	
Over load current	

When these modules are installed, 16 X bits are automatically assigned as the fault status indicator. Each X bit indicates the fault status of each output.

In this example, X10-X27 are assigned as the fault status indicator.

X10: Fault status indicator for Y0

X11: Fault status indicator for Y1



X26: Fault status indicator for Y16

X27: Fault status indicator for Y17

The fault status indicators (X bits) can be reset by performing the indicated operations in the following table:

Fault Status	Operation
Missing external 24VDC	Apply external 24VDC
Open load ¹	Connect the load.
Over temperature	Turn the output (Y bit) off or power cycle the PLC
Over load current	Turn the output (Y bit) off or power cycle the PLC



NOTE 1: Open load detection can be disabled by removing the jumper switch J6 on the module PC board.

Example

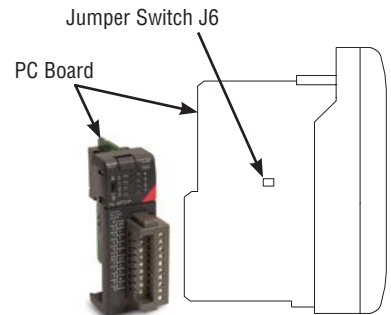
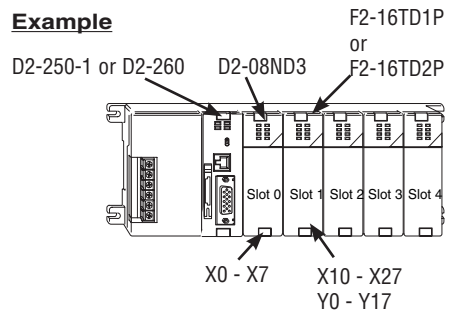

Continued on next two pages.

F2-16TD1P, DC Output With Fault Protection

Inputs per module	16 (status indication)
Outputs per module	16 (current sinking)
Commons per module	1 (2 I/O terminal points)
Output type	NMOS FET (open drain)
Operating voltage	10.2 -26.4 VDC, external
Peak voltage	40VDC
AC frequency	N/A
ON voltage drop	0.7 V (output current 0.5 A)
Overcurrent trip	0.6 A min., 1.2 A max.
Maximum load current	0.25 A continuous, 0.5 A peak
Maximum OFF current	Jumper J6 installed: 200 μ A; J6 removed: 30 μ A
Base power required 5V	70mA
OFF to ON response	0.5 ms
ON to OFF response	0.5 ms
Terminal type	Removable (D2-16IOCON)
Status indicators	Logic Side
Weight	2.0 oz. (25g)
Fuses	None
External DC required	24VDC \pm 10% @ 50mA
External DC overvoltage shutdown	27V, outputs are restored when voltage is within limits

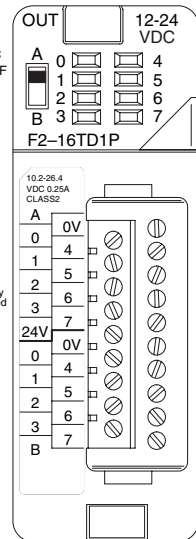
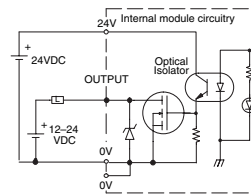
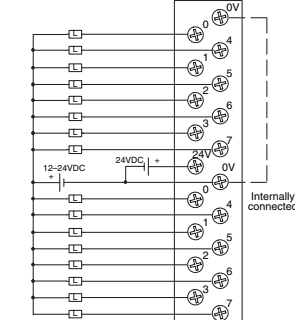
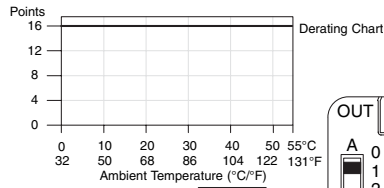

When the A/B switch is in the A position, the LEDs display the output status of the module's first 8 output points. Position B displays the output status of the module's second group of 8 output points.



NOTE 1: Not supported in D2-230, D2-240 and D2-250 CPUs.

NOTE 2: Supporting Firmware: D2-250-1 must be V4.80 or later
D2-260 must be V2.60 or later

NOTE 3: This module does not currently support Think & Do 8.0. It does not support Think & Do Live! or Studio.

F2-16TD2P, DC Output with Fault Protection

Inputs per module	16 (status indication)
Outputs per module	16 (current sourcing)
Commons per module	1
Output type	NMOS FET (open source)
Operating voltage	10.2 -26.4 VDC, external
Peak voltage	40 VDC
AC frequency	N/A
ON voltage drop	0.7 V (output current 0.5 A)
Overcurrent trip	0.6 A min., 1.2 A max.
Maximum load current	0.25 A continuous, 0.5 A peak
Maximum OFF current	Jumper J6 installed: 200 μ A; J6 removed: 30 μ A
Base power required 5V	70mA
OFF to ON response	0.5 ms
ON to OFF response	0.5 ms
Terminal type	Removable (D2-16IOCON)
Status indicators	Logic Side
Weight	2.0 oz. (25g)
Fuses	None
External DC required	24 VDC +/-10% @ 50 mA
External DC overvoltage shutdown	27 V, outputs are restored when voltage is within limits

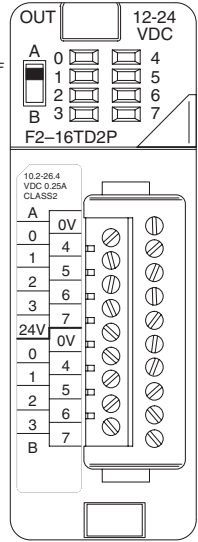
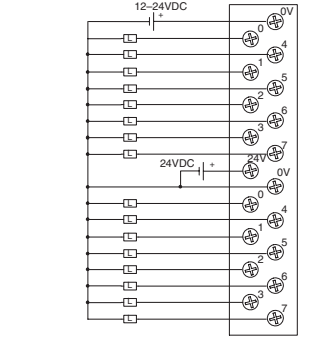
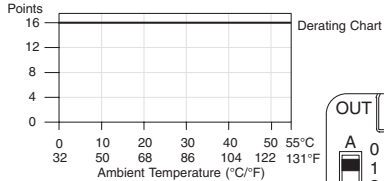

When the A/B switch is in the A position, the LEDs display the output status of the module's first 8 output points. Position B displays the output status of the module's second group of 8 output points.

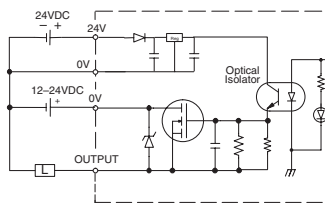

NOTE 1: Not supported in D2-230, D2-240 and D2-250 CPUs.

NOTE 2: Supporting Firmware: D2-250-1 must be V4.80 or later

D2-260 must be V2.60 or later

NOTE 3: This module does not currently support Think & Do 8.0. It does not support Think & Do Live! or Studio.

D2-32TD1, DC Output

Outputs per Module	32 (current sinking)
Commons per Module	4 (8 I/O terminal points)
Output Type	NPN open collector
Operating Voltage	12-24 VDC
Peak Voltage	30VDC
ON Voltage Drop	0.5 VDC maximum
Minimum Load Current	0.2 mA
Max Load Current	0.1 A/point; 3.2 A per module
Max Leakage Current	0.1 mA @ 30VDC
Max Inrush Current	150mA for 10ms
Base Power Required 5VDC	350mA
OFF to ON Response	0.5 ms
ON to OFF Response	0.5 ms
Terminal Type (not included)	Removable 40-pin connector ¹
Status Indicator	Module activity (no I/O status indicators)
Weight	2.1 oz. (60g)
Fuses	None
External DC Power Required	20-28 VDC max. 120mA (all points on)

¹ Connector sold separately.
See Terminal Blocks and Wiring for wiring options.

D2-32TD2, DC Output

Outputs per Module	32 (current sourcing)
Commons per Module	4 (8 I/O terminal points)
Output Type	Transistor
Operating Voltage	12 to 24 VDC
Peak Voltage	30VDC
ON Voltage Drop	0.5 VDC @ 0.1 A
Minimum Load Current	0.2 mA
Max Load Current	0.1A/point; 0.8A/common
Max Leakage Current	0.1 mA @ 30VDC
Max Inrush Current	150mA @ 10ms
Base Power Required 5VDC	350 mA
OFF to ON Response	0.5 ms
ON to OFF Response	0.5 ms
Terminal Type (not included)	Removable 40-pin connector ¹
Status Indicator	Module activity (no I/O status indicators)
Weight	2.1 oz (60g)
Fuses	None

¹ Connector sold separately.
See Terminal Blocks and Wiring for wiring options.

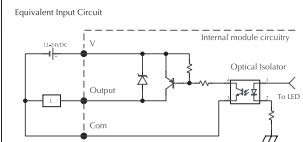
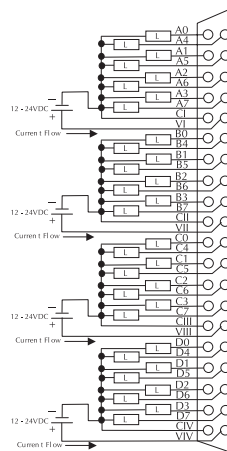
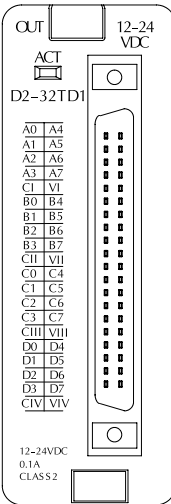
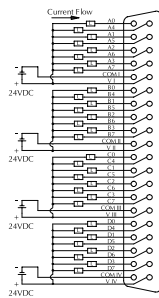
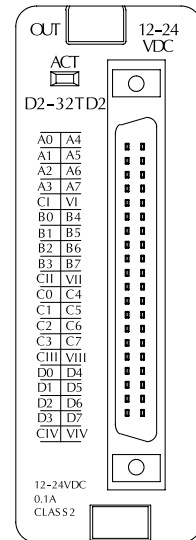
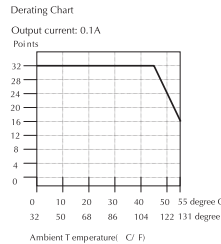
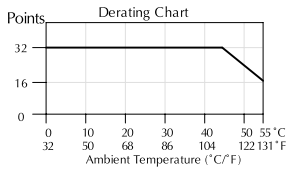

F2-08TA, AC Output

Outputs per Module	8
Commons per Module	2 (Isolated)
Output Type	SSR (Triac with zero crossover)
Operating Voltage	24-140 VAC
Peak Voltage	140VAC
ON Voltage Drop	1.6 V(rms) @ 1.5 A
AC Frequency	47 to 63 Hz
Minimum Load Current	50mA
Max Load Current	1.5 A / pt @ 30°C 1.0 A / pt @ 60°C 4.0 A / common; 8.0 A / module @ 60°C
Max Leakage Current	0.7 mA (rms)
Peak One Cycle Surge Current	15A
Base Power Required 5VDC	250mA
OFF to ON Response	0.5 ms - 1/2 cycle
ON to OFF Response	0.5 ms - 1/2 cycle
Terminal Type (included)	Removable; D2-8IOCON
Status Indicator	Logic side
Weight	3.5 oz.
Fuses	None

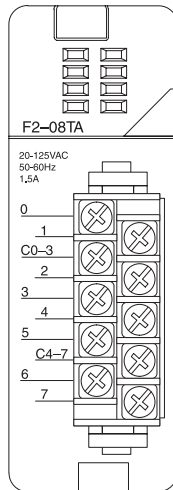
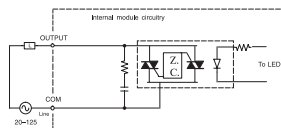
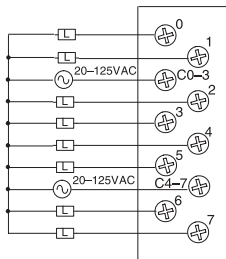
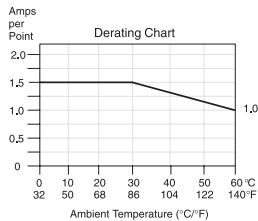

D2-08TA, AC Output

Outputs per Module	8
Commons per Module	1 (2 I/O terminal points)
Output Type	SSR (Triac)
Operating Voltage	15-264 VAC
Peak Voltage	264VAC
ON Voltage Drop	< 1.5 VAC (>0.1A) < 3.0 VAC (<0.1A)
AC Frequency	47 to 63 Hz
Minimum Load Current	10mA
Max Load Current	0.5 A/point; 4A/common
Max Leakage Current	4mA (264VAC, 60Hz) 1.2 mA (100VAC, 60Hz) 0.9 mA (100VAC, 50Hz)
Max Inrush Current	10A for 10ms
Base Power Required 5VDC	250mA
OFF to ON Response	1ms
ON to OFF Response	1ms + 1/2 cycle
Terminal Type (included)	Removable; D2-8IOCON
Status Indicator	Logic side
Weight	2.8 oz. (80g)
Fuses	1 per common, 6.3 A slow blow, non-replaceable

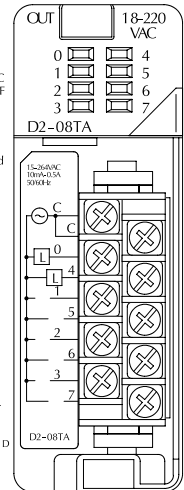
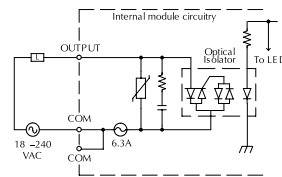
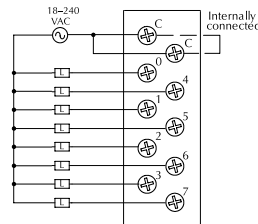
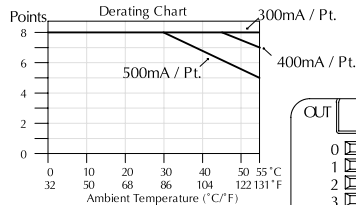

D2-12TA, AC Output

Outputs per Module	12
Outputs Points Consumed	16 (four unused, see chart below)
Commons per Module	2 (isolated)
Output Type	SSR (Triac)
Operating Voltage	15-132 VAC
Peak Voltage	132 VAC
ON Voltage Drop	< 1.5VAC (>50mA) < 4.0VAC (<50mA)
AC Frequency	47 to 63 Hz
Minimum Load Current	10mA
Max Load Current	0.3 A/point; 1.8A/common

Max Leakage Current	2mA (132VAC, 60Hz)
Max Inrush Current	10A for 10ms
Base Power Required 5VDC	350mA
OFF to ON Response	1ms
ON to OFF Response	1ms + 1/2 cycle
Terminal Type (included)	Removable; D2-16IOCON
Status Indicator	Logic side
Weight	2.8 oz. (80g)
Fuses	(2) 1 per common 3.15 A slow blow, replaceable Order D2-FUSE-1 (5 per pack)

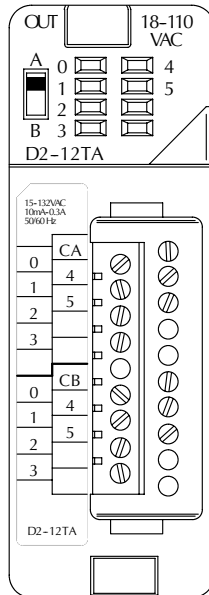
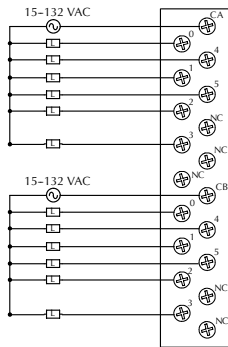
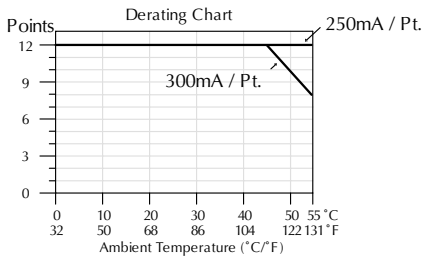

Addresses Used		Addresses Used	
Points	Used?	Points	Used?
Yn+0	Yes	Yn+10	Yes
Yn+1	Yes	Yn+11	Yes
Yn+2	Yes	Yn+12	Yes
Yn+3	Yes	Yn+13	Yes
Yn+4	Yes	Yn+14	Yes
Yn+5	Yes	Yn+15	Yes
Yn+6	No	Yn+16	No
Yn+7	No	Yn+17	No

n is the starting address

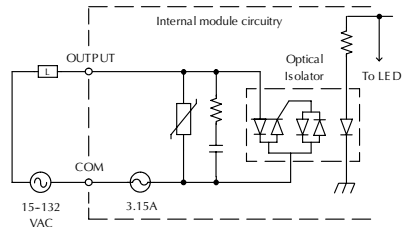

D2-04TRS, Relay Output

Outputs per Module	4
Outputs Points Consumed	8 (only 1st 4pts. are used)
Commons per Module	4 (isolated)
Output Type	Relay, form A (SPST)
Operating Voltage	5-30 VDC / 5-240 VAC
Peak Voltage	30VDC, 264VAC
ON Voltage Drop	0.72 VDC maximum
AC Frequency	47 to 63 Hz
Minimum Load Current	10mA
Max Load Current (resistive)	4A/point; 8A/module (resistive)

Max Leakage Current	0.1 mA @ 264VAC
Max Inrush Current	5A for < 10ms
Base Power Required 5VDC	250mA
OFF to ON Response	10ms
ON to OFF Response	10ms
Terminal Type (included)	Removable; D2-8IOCON
Status Indicator	Logic side
Weight	2.8 oz. (80g)
Fuses	1 per point 6.3 A slow blow, replaceable Order D2-FUSE-3 (5 per pack)

Typical Relay Life (Operations)				
Voltage & Type of Load	Load Current			
	1A	2A	3A	4A
24 VDC Resistive	500k	200k	100k	50k
24 VDC Solenoid	100k	40k	—	—
110 VAC Resistive	500k	250k	150k	100k
110 VAC Solenoid	200k	100k	50k	—
220 VAC Resistive	350k	150k	100k	50k
220 VAC Solenoid	100k	50k	—	—

At 24 VDC, solenoid (inductive) loads over 2A cannot be used.

At 100 VAC, solenoid (inductive) loads over 3A cannot be used.

At 220 VAC, solenoid (inductive) loads over 2A cannot be used.

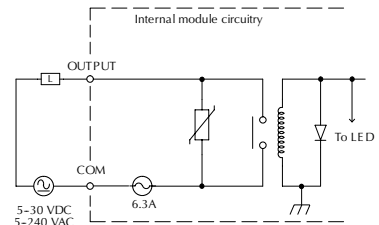
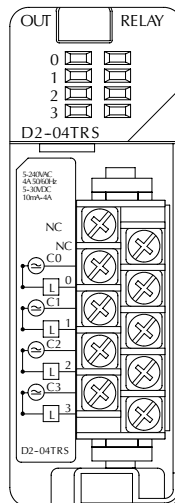
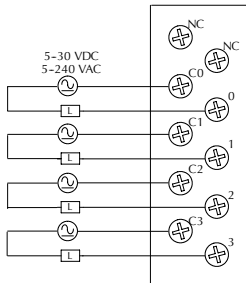
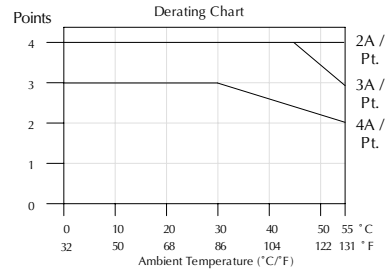

D2-08TR, Relay Output

Outputs per Module	8
Outputs Points Consumed	8
Commons per Module	1 (2 I/O terminals)
Output Type	Relay, form A (SPST)
Operating Voltage	5-30 VDC; 5-240 VAC
Peak Voltage	30VDC, 264VAC
ON Voltage Drop	N/A
AC Frequency	47 to 60 Hz
Minimum Load Current	5mA @ 5VDC
Max Load Current (resistive)	1A/point; 4A/common

Max Leakage Current	0.1 mA @ 265VAC
Max Inrush Current	Output: 3A for 10ms Common: 10A for 10ms
Base Power Required 5VDC	250mA
OFF to ON Response	12ms
ON to OFF Response	10ms
Terminal Type (included)	Removable; D2-8IOCON
Status Indicator	Logic side
Weight	3.9 oz. (110g)
Fuses	One 6.3 A slow blow, replaceable Order D2-FUSE-3 (5 per pack)

Typical Relay Life (Operations)		
24 VDC Resistive	1A	500k
24 VDC Solenoid	1A	100k
110 VDC Resistive	1A	500k
110 VDC Solenoid	1A	200k
220 VAC Resistive	1A	350k
220 VAC Solenoid	1A	100k

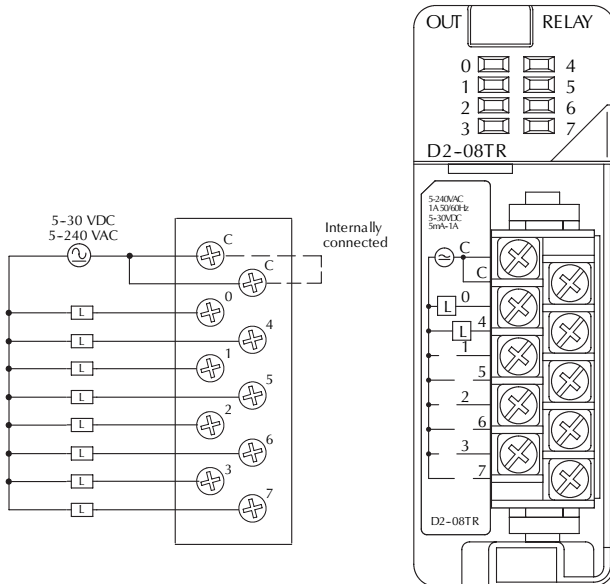
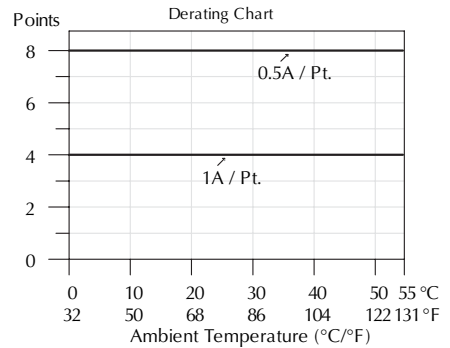

F2-08TR, Relay Output

Outputs per Module	8
Outputs Points Consumed	8
Commons per Module	2 (isolated), 4-pt. per common
Output Type	8, Form A (SPST normally open)
Operating Voltage	7A @ 12-28 VDC, 12-250 VAC; 0.5 A @ 120VDC
Peak Voltage	150VDC, 265 VAC
ON Voltage Drop	N/A
AC Frequency	47 to 63Hz
Minimum Load Current	10mA @ 12VDC
Max Load Current (resistive)	10A/point ³ (subject to derating) Max of 10A/common
Max Leakage Current	N/A
Max Inrush Current	12A
Base Power Required 5VDC	670mA
OFF to ON Response	15ms (typical)
ON to OFF Response	5ms (typical)
Terminal Type (included)	Removable; D2-8IOCON
Status Indicator	Logic side
Weight	5.5 oz. (156g)
Fuses	None

Typical Relay Life ¹ (Operations) at Room Temperature			
Voltage & Type of Load ²	Load Current		
	50mA	5A	7A
24 VDC Resistive	10M	600k	300k
24 VDC Solenoid	-	150k	75k
110 VDC Resistive	-	600k	300k
110 VDC Solenoid	-	500k	200k
220 VAC Resistive	-	300k	150k
220 VAC Solenoid	-	250k	100k

1) Contact life may be extended beyond those values shown with the use of arc suppression techniques described in the DL205 User Manual. Since these modules have no leakage current, they do not have built-in snubber. For example, if you place a diode across a 24 VDC inductive load, you can significantly increase the life of the relay.

2) At 120 VDC 0.5A resistive load, contact life cycle is 200k cycles.

3) Normally closed contacts have 1/2 the current handling capability of the normally open contacts.

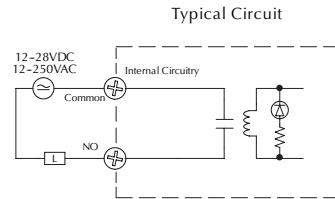
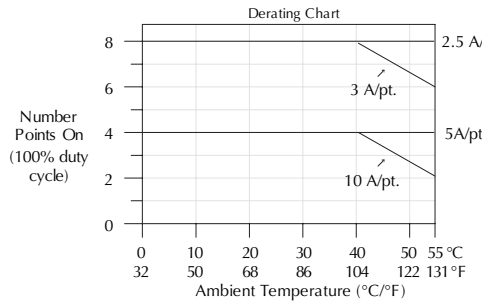
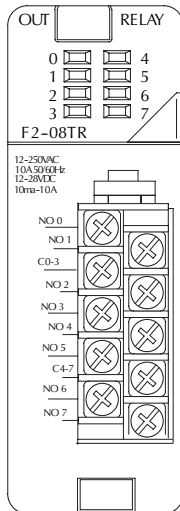
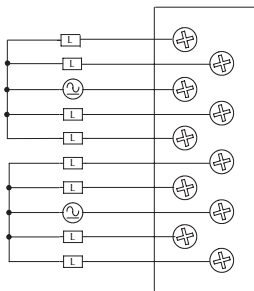

F2-08TRS, Relay Output

Outputs per Module	8
Outputs Points Consumed	8
Commons per Module	8 (isolated)
Output Type	3, Form C (SPDT) 5, Form A (SPST normally open)
Operating Voltage	7A @ 12-28 VDC, 12-250 VAC 0.5A @ 120VDC
Peak Voltage	150VDC, 265VAC
ON Voltage Drop	N/A
AC Frequency	47 to 63 Hz
Minimum Load Current	10mA @ 12VDC
Max Load Current (resistive)	7A/point ³ (subject to derating)
Max Leakage Current	N/A
Max Inrush Current	12A
Base Power Required 5VDC	670mA
OFF to ON Response	15ms (typical)
ON to OFF Response	5ms (typical)
Terminal Type (included)	Removable; D2-16IOCON
Status Indicator	Logic side
Weight	5.5oz. (156g)
Fuses	None

Typical Relay Life ¹ (Operations) at Room Temperature			
Voltage & Type of Load ²	Load Current		
	50mA	5A	7A
24 VDC Resistive	10M	600k	300k
24 VDC Solenoid	-	150k	75k
110 VDC Resistive	-	600k	300k
110 VDC Solenoid	-	500k	200k
220 VAC Resistive	-	300k	150k
220 VAC Solenoid	-	250k	100k

1) Contact life may be extended beyond those values shown with the use of arc suppression techniques described in the DL205 User Manual. Since these modules have no leakage current, they do not have built-in snubber. For example, if you place a diode across a 24VDC inductive load, you can significantly increase the life of the relay.
2) At 120VDC 0.5 A resistive load, contact life cycle is 200k cycles.
3) Normally closed contacts have 1/2 the current handling capability of the normally open contacts.

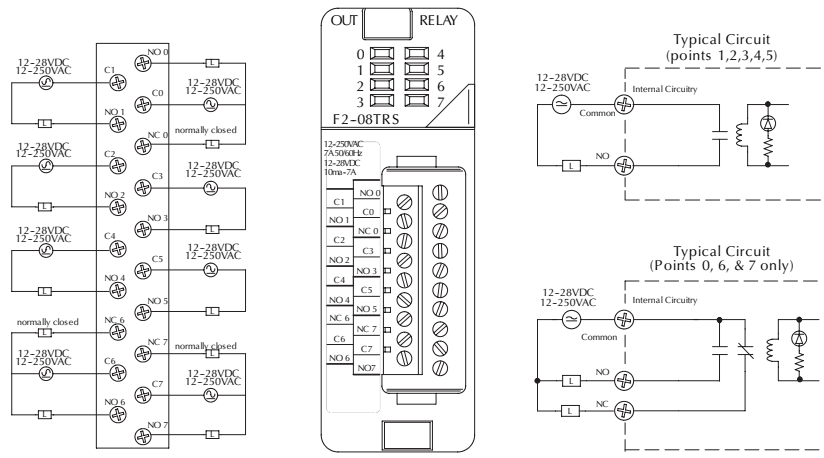
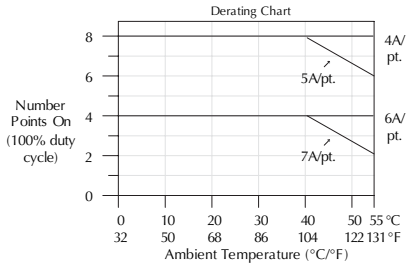

D2-12TR, Relay Output

Outputs per Module	12
Outputs Points Consumed	16 (four unused, see chart below)
Commons per Module	2 (6-pts. per common)
Output Type	Relay, form A (SPST)
Operating Voltage	5-30 VDC; 5-240 VAC
Peak Voltage	30VDC; 264VAC
ON Voltage Drop	N/A
AC Frequency	47 to 60 Hz
Minimum Load Current	5mA @ 5VDC
Max Load Current (resistive)	1.5 A/point; Max of 3A/common
Max Leakage Current	0.1 mA @ 265VAC
Max Inrush Current	Output: 3A for 10ms Common: 10A for 10 ms
Base Power Required 5VDC	450mA
OFF to ON Response	10ms
ON to OFF Response	10ms
Terminal Type (included)	Removable; D2-16IOCON
Status Indicator	Logic side
Weight	4.6 oz. (130g)
Fuses	(2) 4A slow blow, replaceable Order D2-FUSE-4 (5 per pack)

Typical Relay Life (Operations)		
24 VDC Resistive	1A	500k
24 VDC Solenoid	1A	100k
110 VDC Resistive	1A	500k
110 VDC Solenoid	1A	200k
220 VAC Resistive	1A	350k
220 VAC Solenoid	1A	100k

Addresses Used			
Points	Used?	Points	Used?
Yn+0	Yes	Yn+10	Yes
Yn+1	Yes	Yn+11	Yes
Yn+2	Yes	Yn+12	Yes
Yn+3	Yes	Yn+13	Yes
Yn+4	Yes	Yn+14	Yes
Yn+5	Yes	Yn+15	Yes
Yn+6	No	Yn+16	No
Yn+7	No	Yn+17	No

n is the starting address

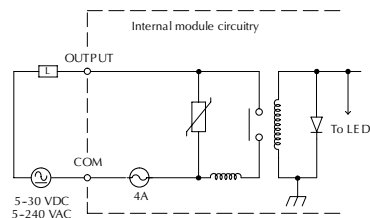
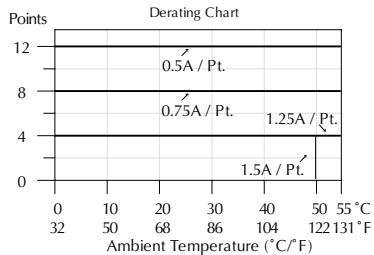
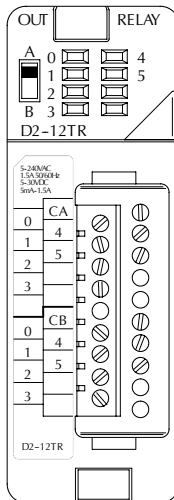
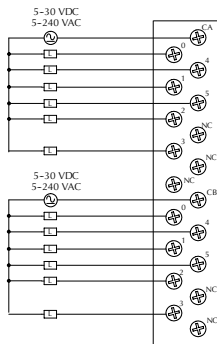

D2-08CDR, 4 pt. DC Input / 4pt. Relay Output

General Specifications	
Base Power Required 5VDC	200mA
Terminal Type (included)	Removable; D2-8IOCON
Status Indicator	Logic side
Weight	3.5 oz. (100g)
Input Specifications	
Inputs per Module	4 (sink/source)
Input Points Consumed	8 (only first 4-pt. are used)
Commons per Module	1
Input Voltage Range	20-28 VDC
Peak Voltage	30VDC
ON Voltage Level	19VDC minimum
OFF Voltage Level	7VDC maximum
AC Frequency	N/A
Input Impedance	4.7 kΩ
Input Current	5mA @ 24VDC
Maximum Current	8mA @ 30VDC
Minimum ON Current	4.5 mA
Maximum OFF Current	1.5 mA
OFF to ON Response	1 to 10 ms
ON to OFF Response	1 to 10 ms
Fuses (input circuits)	None

Output Specifications	
Outputs per Module	4
Outputs Points Consumed	8 (only first 4-pt. are used)
Commons per Module	1
Output Type	Relay, form A (SPST)
Operating Voltage	5-30 VDC; 5-240 VAC
Peak Voltage	30VDC; 264VAC
ON Voltage Drop	N/A
AC Frequency	47 to 63 Hz
Minimum Load Current	5mA @ 5VDC
Max Load Current (resistive)	1A/point ; 4A/module
Max Leakage Current	0.1 mA @ 264VAC
Max Inrush Current	3A for < 100ms 10A for < 10ms (common)
OFF to ON Response	12ms
ON to OFF Response	10ms
Fuses (output circuits)	1 (6.3A slow blow, replaceable); Order D2-FUSE-3 (5 per pack)

Typical Relay Life (Operations)		
24 VDC Resistive	1A	500k
24 VDC Solenoid	1A	100k
110 VDC Resistive	1A	500k
110 VDC Solenoid	1A	200k
220 VAC Resistive	1A	350k
220 VAC Solenoid	1A	100k

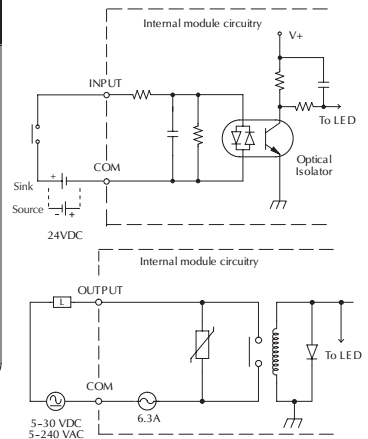
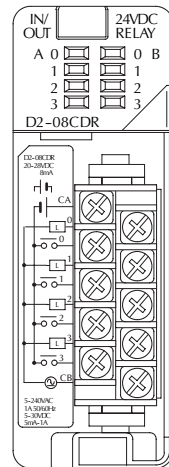
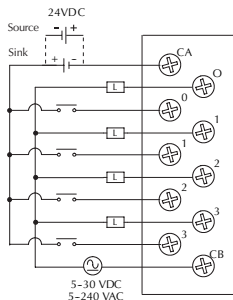
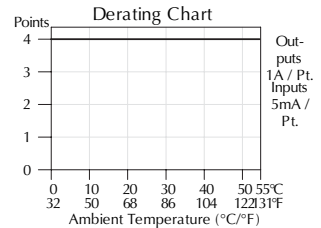

NOTES:

DL205 Analog Input Modules

F2-04AD-1 4-Channel 4-20mA Analog Input Module

This module can be powered by either a 12VDC or 24VDC power supply, and is a direct replacement for F2-04AD-1L modules.	
Number of Channels	4, single ended (1 common)
Input Ranges	4 to 20 mA current
Resolution	12-bit (1 in 4096)
Active Low-pass Filtering	-3 dB at 120 Hz, 2 poles (-12 dB per octave)
Input Impedance	250Ω ±0.1%, 1/2W current input
Absolute Maximum Ratings	-40mA to +40mA, current input
Converter Type	Successive approximation
Conversion Time (PLC Update Rate)	1 channel per scan maximum (D230 CPU); 4 channels per scan maximum (D2-240, D2-250(-1), D2-260, and D2-262 CPUs)
Linearity Error (End to End)	±1 count (0.025% of full scale) maximum
Input Stability	±1 count
Full Scale Calibration Error (offset error not included)	±12 counts max., @ 20 mA current input
Offset Calibration Error	±7 counts max., @ 4mA current input
Step Response	4.9 ms to 95% of F.S. change
Maximum Inaccuracy	±.5% @ 77°F (25°C) ±.65% 32° to 140°F (0° to 60°C)
Accuracy vs. Temperature	±50 ppm/°C maximum full scale (including max. offset change)
Recommended Fuse	0.032 A, Series 217 fast-acting, current inputs
Digital Input Points Required	16 (X) input points (12 binary data bits, 2 channel ID bits, 2 diagnostic bits)
Base Power Required 5 VDC	100mA
External Power Supply	5mA maximum, +10 to +30 VDC
Operating Temperature	32° to 140°F (0° to 60°C)
Storage Temperature	-4° to 158°F (-20° to 70°C)
Relative Humidity	5 to 95% (non-condensing)
Environmental Air	No corrosive gases permitted
Shock & Vibration	MIL STD 810C 514.2
Noise Immunity	NEMA ICS3-304
Terminal Type (included)	Removable; D2-8IOCON

One count in the specification table is equal to one least significant bit of the analog data value (1 in 4096).

F2-04AD-1 4-Channel 4-20mA Analog Input

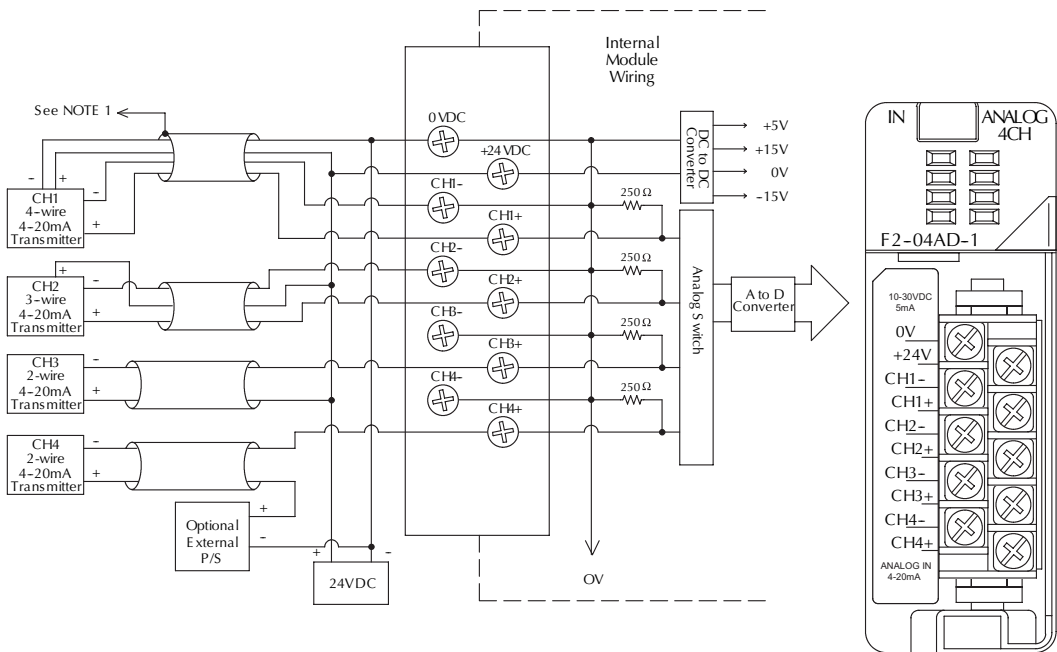

Note 1: Shields should be grounded at the signal source

More than one external power supply can be used provided all the power supply commons are connected. A Series 217, 0.032A, fast-acting fuse is recommended for 4-20 mA current loops. If the power supply common of an external power supply is not connected to 0VDC on the module, then the output of the external transmitter must be isolated. To avoid "ground loop" errors, recommended 4-20 mA transmitter types are:

2 or 3 wire: Isolation between input signal and power supply.

4 wire: Isolation between input signal, power supply, and 4-20 mA output

F2-08AD-1 8-Channel 4-20mA Analog Input Module

Number of Channels	8, single ended (1 common)
Input Ranges	4 to 20 mA current
Resolution	12-bit (1 in 4096)
Low-pass Filtering	-3dB at 200Hz, (-6dB per octave)
Input Impedance	250Ω ±0.1%, 1/2W current input
Absolute Maximum Ratings	-45mA to +45mA
Converter Type	Successive approximation
Conversion Time (PLC Update Rate)	(D2-230 CPU) 1 channel per scan maximum (D2-240, D2-250(-1), D2-260, and D2-262 CPUs) 8 channels per scan maximum
Linearity Error (End to End)	±1 count (0.025% of full scale) maximum
Input Stability	±1 count
Full Scale Calibration Error (offset error not included)	±5 counts max., @ 20mA current input
Offset Calibration Error	±2 counts max., @ 4mA current input
Step Response	1 ms to 95% of F.S. change

Maximum Inaccuracy	±.1% @ 77°F (25°C) ±.25% 32° to 140°F (0° to 60°C)
Accuracy vs. Temperature	±50 ppm/°C maximum full scale (including max. offset change of two counts)
Recommended Fuse	0.032 A, Series 217 fast-acting, current inputs
Digital Input Points Required	16 (X) input points (12 binary data bits, 3 channel ID bits, 1 broken transmitter bit)
Base Power Required 5VDC	100mA
External Power Supply	5mA maximum, +10 to +30 VDC
Operating Temperature	32° to 140°F (0° to 60°C)
Storage Temperature	-4° to 158°F (-20° to 70°C)
Relative Humidity	5 to 95% (non-condensing)
Environmental Air	No corrosive gases permitted
Shock & Vibration	MIL STD 810C 514.2
Noise Immunity	NEMA ICS3-304
Terminal Type (included)	Removable; D2-8IOCON

One count in the specification table is equal to one least significant bit of the analog data value (1 in 4096).

F2-08AD-1 8-Channel 4-20mA Analog Input

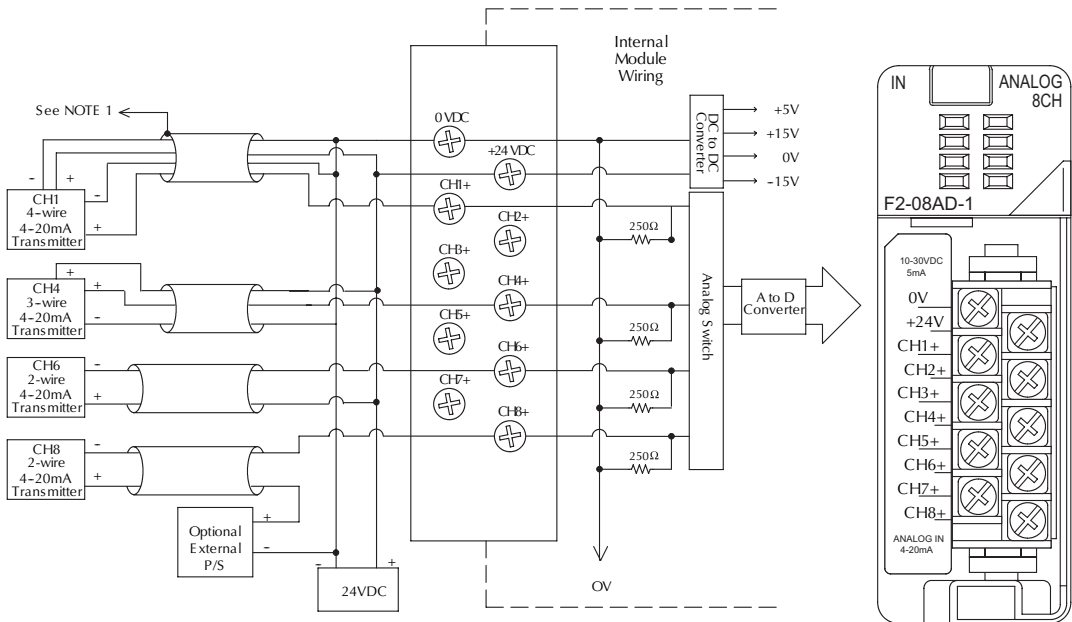

Note 1: Shields should be grounded at the signal source.

More than one external power supply can be used provided all the power supply commons are connected. A Series 217, 0.032A, fast-acting fuse is recommended for 4-20 mA current loops. If the power supply common of an external power supply is not connected to 0 VDC on the module, then the output of the external transmitter must be isolated. To avoid "ground loop" errors, recommended 4-20 mA transmitter types are:

2 or 3 wire: Isolation between input signal and power supply.

4 wire: Isolation between input signal, power supply, and 4-20 mA output

F2-04AD-2 4-Channel Voltage Analog Input Module

This module can be powered by either a 12VDC or 24VDC power supply, and is a direct replacement for F2-04AD-2L modules.

Number of Channels	4, single ended (1 common)
Input Ranges	0 to 5V, 0 to 10 V, $\pm 5V$, $\pm 10 V$
Resolution	12-bit (1 in 4096)
Active Low-pass Filtering	-3 dB at 80 Hz, 2 poles (-12 dB per octave)
Input Impedance	$>20M\Omega$
Absolute Maximum Ratings	-75 to +75 VDC
Converter Type	Successive approximation
Conversion Time (PLC Update Rate)	1 channel per scan maximum (D2-230 CPU) 4 channels per scan maximum (D2-240, D2-250(-1) and D2-260 CPUs)
Linearity Error (End to End)	± 1 count (0.025% of full scale) maximum ± 2 counts maximum (bi-polar)
Input Stability	± 1 count
Full Scale Calibration Error (offset error not included)	± 3 counts maximum
Offset Calibration Error	± 1 count maximum (0V input)
Step Response	8.2 ms to 95% of F.S change

Maximum Inaccuracy	$\pm 1\%$ @ 77°F (25°C) $\pm 3\%$ 32° to 140°F (0° to 60°C)
Accuracy vs. Temperature	± 50 ppm/°C full scale calibration change (including maximum offset change)
Digital Input Points Required	16(x) input points (12 binary data bits, 2 channel ID bits)
Base Power Required 5VDC	110mA
External Power Supply	5mA maximum, +10 to +30 VDC
Operating Temperature	32° to 140°F (0 to 60°C)
Storage Temperature	-4° to 158°F (-20° to 70°C)
Relative Humidity	5 to 95% (non-condensing)
Environmental Air	No corrosive gases permitted
Shock & Vibration	MIL STD 810C 514.2
Noise Immunity	NEMA ICS3-304
Terminal Type (included)	Removable; D2-8IOCON

One count in the specification table is equal to one least significant bit of the analog data value (1 in 4096).

F2-04AD-2 4-Channel Voltage Analog Input

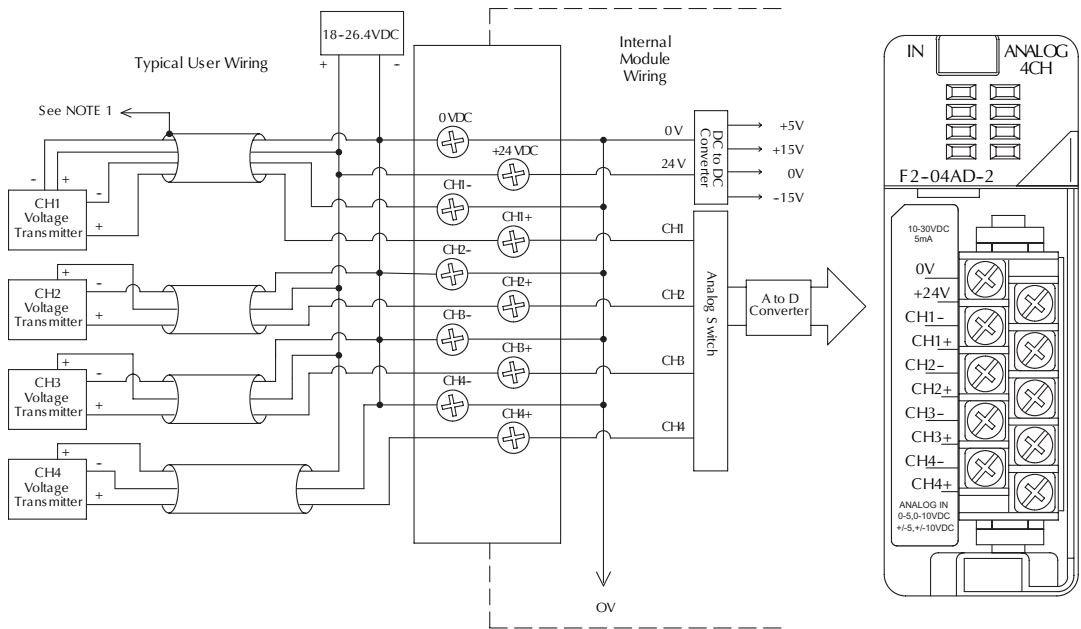

Note 1: Shields should be grounded at the signal source.

F2-08AD-2 8-Channel Voltage Analog Input Module

Number of Channels	8, single ended (1 common)
Input Ranges	0 to 5V, 0 to 10 V, $\pm 5V$, ± 10 VDC
Resolution	12 bit (1 in 4095) uni-polar 13 bit (-4095 to 4095) bi-polar
Active Low-pass Filtering	-3dB at 200 Hz, (-6dB per octave)
Input Impedance	>20M Ω
Absolute Maximum Ratings	-75 to +75 VDC
Converter Type	Successive approximation
Conversion Time (PLC Update Rate)	1 channel per scan maximum (D2-230 CPU) 8 channels per scan maximum (D2-240, D2-250(-1) and D2-260 CPUs)
Linearity Error (End to End)	± 1 count (0.025% of full scale) maximum
Input Stability	± 1 count
Full Scale Calibration Error (offset error not included)	± 3 counts maximum
Offset Calibration Error	± 1 count maximum (0V input)
Step Response	1ms to 95% of F.S. change

Maximum Inaccuracy	$\pm 1.1\%$ @ 77°F (25°C) $\pm 3\%$ 32° to 140°F (0° to 60°C)
Accuracy vs. Temperature	± 50 ppm/°C maximum full scale (including max. offset change of 2 counts)
Digital Input Points Required	16 (X) input points, (12 binary data bits, 3 channel ID bits, 1 sign bit, 1 diagnostic bit)
Base Power Required 5VDC	100mA
External Power Supply	5mA maximum, +10 to +30 VDC
Operating Temperature	32° to 140°F (0° to 60°C)
Storage Temperature	-4° to 158°F (-20° to 70°C)
Relative Humidity	5 to 95% (non-condensing)
Environmental Air	No corrosive gases permitted
Shock & Vibration	MIL STD 810C 514.2
Noise Immunity	NEMA ICS3-304
Terminal Type (included)	Removable; D2-8IOCON

One count in the specification table is equal to one least significant bit of the analog data value (1 in 4096). Includes circuitry to automatically detect broken or open transmitters.

F2-08AD-2 8-Channel Voltage Analog Input

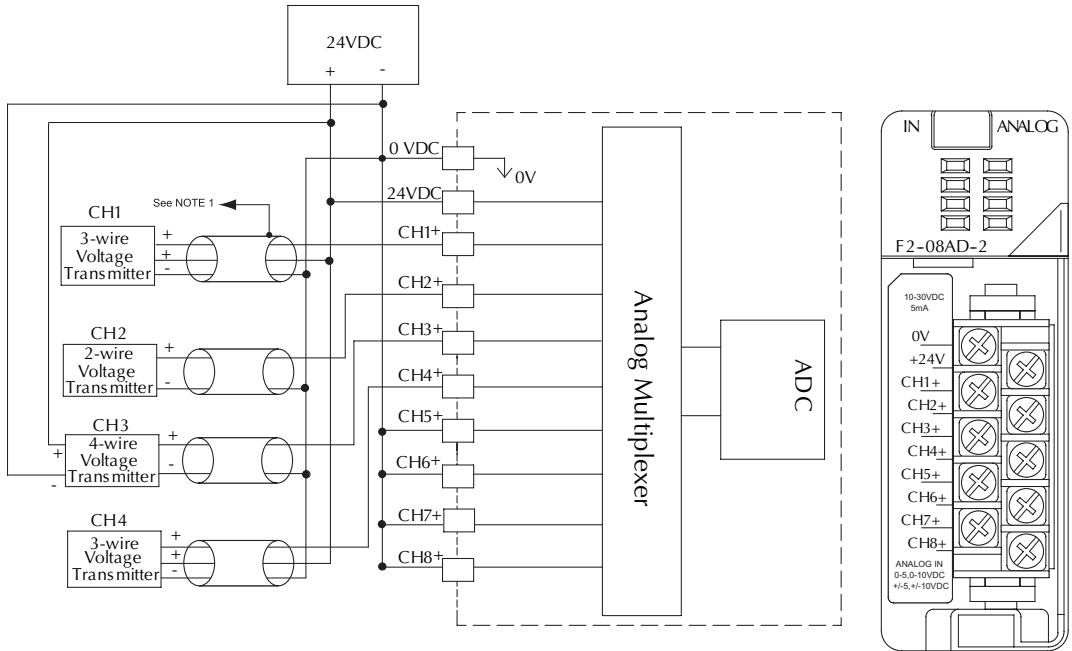

Note 1: Shields should be grounded at the signal source.

Note 2: Connect all external power supply commons.

Note 3: Connect unused channels (CH5+, CH6+, CH7+, CH8+ in this example) to 0VDC.

DL205 RTD and Thermocouple Modules

F2-04RTD 4-Channel RTD Input Module

Number of Channels	4
Input Ranges	Type Pt100: -200.0/850.0°C, -328/1562°F Type Pt1000: -200.0/595.0°C, -328/1103°F Type jPt100: -38.0/450.0°C, -36/842°F Type CU-10/25z: -200.0/260.0°C, -328/500°F
Resolution	16 bit (1 in 65535)
Display Resolution	±0.1°C, ±0.1°F (±3276.7)
RTD Excitation Current	200µA
Input Type	Differential
Notch Filter	>100 db notches at 50/60 Hz -3db=13.1Hz
Maximum Setting Time	100ms (full-scale step input)
Common Mode Range	0-5 VDC
Absolute Maximum Ratings	Fault protected inputs to ±50 VDC
Sampling Rate	160 ms per channel

Converter Type	Charge Balancing
Linearity Error	±0.05°C maximum, ±0.1°C typical
Maximum Inaccuracy	±1°C
PLC Update Rate	4 channel/scan max., 240/250(-1)/D2-260CPUs 1 channel per scan max., 230 CPU
Digital Input Points Required	32 input points (16 binary data bits, 2 channel ID bits, 4 fault bits)
Base Power Required 5VDC	90mA
Operating Temperature	32° to 140°F (0° to 60°C)
Storage Temperature	-4° to 158°F (-20° to 70°C)
Temperature Drift	None (self-calibrating)
Relative Humidity	5 to 95% (non-condensing)
Environmental Air	No corrosive gases permitted
Shock & Vibration	MIL STD 810C 514.2
Noise Immunity	NEMA ICS3-304
Terminal Type (included)	Removable; D2-8IOCON

F2-04RTD 4-Channel RTD Input

Note 1

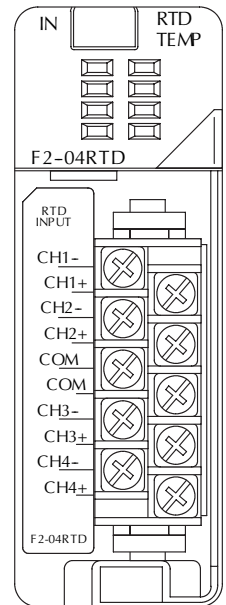
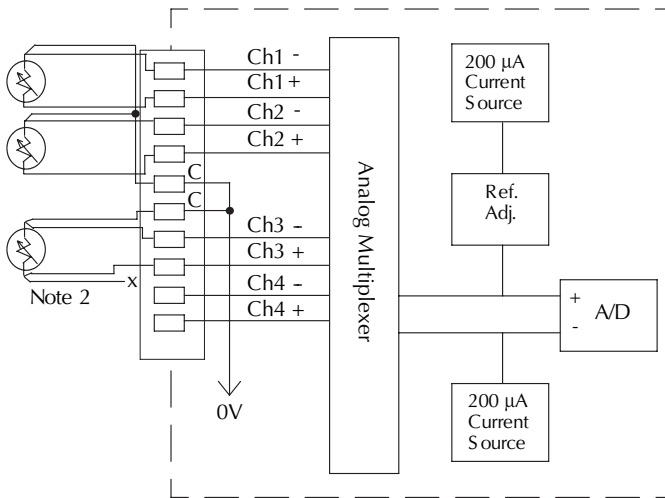

Notes:

1. The three wires connecting the RTD to the module must be the same type and length. Do not use the shield or drain wire for the third connection.
2. If an RTD sensor has four wires, the plus sense wire should be left unconnected as shown.
3. This module is not compatible with the ZIPLink wiring systems.

F2-04THM 4-Channel Thermocouple Input Module

Number of Channels	4, differential
Common Mode Range	±5VDC
Common Mode Rejection	90dB min. @ DC, 150dB min. @ 50/60 Hz.
Input Impedance	1 MΩ
Absolute Maximum Ratings	Fault-protected inputs to ±50VDC
Accuracy vs. Temperature	±5 ppm/°C maximum full scale calibration (including maximum offset change)
PLC Update Rate	4 channels per scan max. D2-240/250(-1)/D2-260 CPU, H2-EBC(-F); 1 chan. per scan max. D2-230 CPU
Digital Input Points Required	32 (X) input points (16 binary data bits, 2 channel ID bits, 4 diagnostic bits)
External Power Supply	60mA maximum, 18 to 26.4 VDC
Base Power Required 5VDC	110mA
Operating Temperature	32° to 140°F (0° to 60°C)
Storage Temperature	-4° to 158°F (-20° to 70°C)
Relative Humidity	5 to 95% (non-condensing)
Environmental Air	No corrosive gases permitted
Shock & Vibration	MIL STD 810C 514.2
Noise Immunity	NEMA ICS3-304
Terminal Type (included)	Non-removable

CPU Firmware Required	
CPU	Firmware Required
D2-230	V1.06
D2-240	V2.5
D2-250	V1.06
D2-250-1, D2-260	All firmware versions work

Notes:

- 1: Terminate shields at the respective signal source.
- 2: Connect unused channels to a common terminal (0V, CH4+, CH4).
- 3: When using 0-156 mV and 5V ranges, connect (-) or (0) volts terminal to 0V to ensure common mode range acceptance.
4. This module is not compatible with the ZIPLink wiring system.

F2-04THM 4-Channel Thermocouple Input

Input Ranges	Type J	-190 to 760°C	-310 to 1400°F
	Type E	-210 to 1000°C	-346 to 1832°F
	Type K	-150 to 1372°C	-238 to 2502°F
	Type R	65 to 1768°C	149 to 3214°F
	Type S	65 to 1768°C	149 to 3214°F
	Type T	-230 to 400°C	-382 to 752°F
	Type B	529 to 1820°C	984 to 3308°F
	Type N	-70 to 1300°C	-94 to 2372°F
	Type C	65 to 2320°C	149 to 4208°F
Display Resolution	±0.1°C or ±0.1°F		
Cold Junction Compensation	Automatic		
Conversion Time	100ms per channel		
Warm-Up Time	30 minutes typically ± 1°C repeatability		
Linearity Error (End to End)	±.05°C maximum, ±.01°C typical		
Maximum Inaccuracy	±3°C (excluding thermocouple error)		
Voltage Input Specifications			
Voltage Ranges	0-5V, ±5V, 0-156.25 mV, ±156.25 mVDC		
Resolution	16 bit (1 in 65535)		
Full Scale Calibration Error (Offset Error Included)	±13 counts typical ±33 maximum		
Offset Calibration Error	±1 count maximum, @ 0V input		
Linearity Error (End to End)	±1 count maximum		
Maximum Inaccuracy	±.02% @ 25°C (77°F)		

Thermocouple input wiring diagram

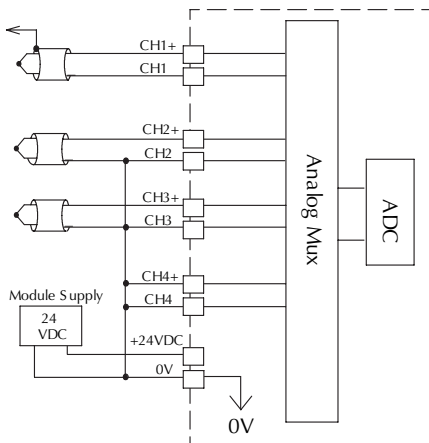

See Notes 1 and 2

Voltage input wiring diagram

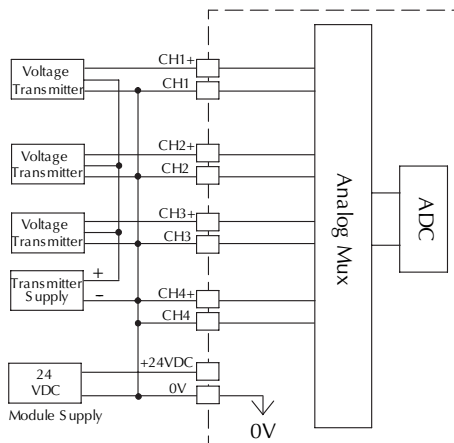

See Notes 2 and 3

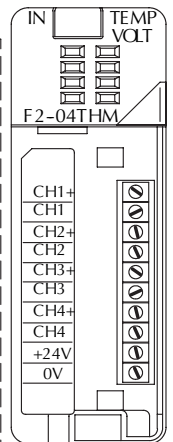

DL205 Analog Output Modules

F2-02DA-1 2-Channel 4-20mA Analog Output Module

This module requires a 24VDC user power supply for operation. See the F2-02DA-1L on the next page if you want to use a 12VDC supply. All other specifications are the same.	
Number of Channels	2
Output Ranges	4 to 20 mA
Resolution	12 bit (1 in 4096)
Output Type	Single ended, one common
Digital Output Points Required	16 (Y) output points (12 binary data bits, 2 channel ID bits)
Maximum Loop Supply	30VDC
Peak Output Voltage	40VDC (clamped by transient voltage suppressor)
Load Impedance	0 Ω minimum
Maximum Load/Power Supply	620 Ω /18 V, 910 Ω /24 V, 1200 Ω /30V
PLC Update Rate	1 channel per scan maximum D2-230 CPU 2 channels per scan maximum (D2-240, D2-250(-1) and D2-260 CPUs)
Linearity Error (end to end)	± 1 count ($\pm 0.025\%$ of full scale) maximum
Conversion Settling Time	100 μ s maximum (full scale change)
Full Scale Calibration Error (offset error included)	± 5 counts max., 20mA @77°F (25°C)
Offset Calibration Error	± 3 counts max., 4mA @ 77°F (25°C)
Accuracy vs. Temperature	± 50 ppm/°C full scale calibration change (including maximum offset change of 2 counts)
Maximum Inaccuracy	0.1% @ 77°F (25°C) 0.3% @ 32° to 140°F (0° to 60°C)
Base Power Required 5VDC	40mA
External Power Supply	18 to 30 VDC, 60mA. (add 20 mA for each current loop used)
Operating Temperature	32° to 140°F (0° to 60°C)
Storage Temperature	-4 to 158°F (-20 to 70°C)
Relative Humidity	5% to 95% (non-condensing)
Environmental Air	No corrosive gases permitted
Shock & Vibration	MIL STD 810C 514.2
Noise Immunity	NEMA ICS3-304
Terminal Type (included)	Removable; D2-8IOCON

One count in the specification table is equal to one least significant bit of the analog data value (1 in 4096).

F2-02DA-1 2-Channel 4-20mA Analog Output

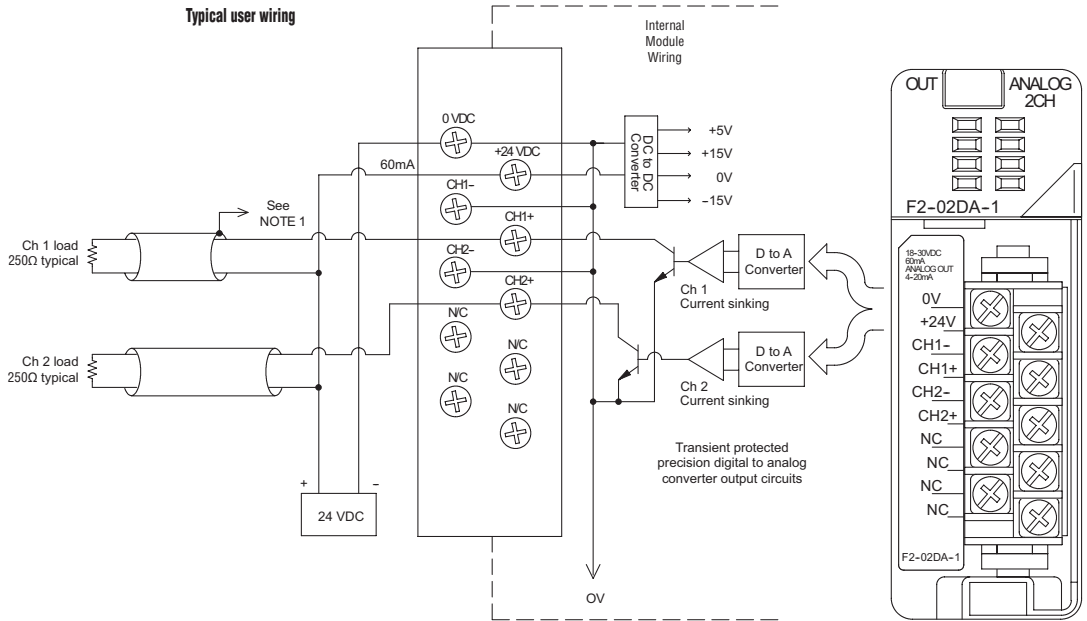

NOTE 1: Shields should be connected to the 0V of the module or the 0V of the R/S.

NOTE 2: Unused current outputs should remain open (no connections) for minimum power consumption.

F2-02DA-1L 2-Channel 4-20mA Analog Output Module

This module requires a 12 VDC user power supply for operation. See the F2-02DA-1 on the previous page if you want to use a 24 VDC supply. All other specifications are the same.

Number of Channels	2
Output Ranges	4 to 20 mA
Resolution	12 bit (1 in 4096)
Output Type	Single ended, 1 common
Digital Output Points Required	16(Y) output points (12 binary data bits, 2 channel ID bits)
Maximum Loop Supply	30VDC
Peak Output Voltage	40VDC (clamped by transient voltage suppressor)
Load Impedance	0Ω minimum
Maximum Load/Power Supply	620Ω/18V, 910Ω/24V, 1200Ω/30V
PLC Update Rate	1 channel per scan maximum (D2-230 CPU) 2 channels per scan maximum (D2-240, D2-250(-1) and D2-260 CPUs)
Linearity Error (end to end)	±1 count (0.025% of full scale) maximum
Conversion Settling Time	100 μs maximum (full scale change)
Full Scale Calibration Error (offset error included)	±5 counts max., 20 mA @ 77°F (25°C)
Offset Calibration Error	±3 counts max., 4mA @ 77°F (25°C)

Accuracy vs. Temperature	±50 ppm/°C full scale calibration change (including maximum offset change of 2 counts)
Maximum Inaccuracy	+0.1% @ 77°F (25°C) ±0.3% @ 32 to 140°F (0 to 60°C)
Base Power Required 5VDC	40mA
External Power Supply	10 to 15 VDC, 70 mA (add 20 mA for each current loop used)
Operating Temperature	32° to 140°F (0° to 60°C)
Storage Temperature	-4° to 158°F (-20° to 70°C)
Relative Humidity	5 to 95% (non-condensing)
Environmental Air	No corrosive gases permitted
Shock & Vibration	MIL STD 810C 514.2
Noise Immunity	NEMA ICS3-304
Terminal Type (included)	Removable; D2-8IOCON

One count in the specification table is equal to one least significant bit of the analog data value (1 in 4096).

F2-02DA-1L 2-Channel 4-20mA Analog Output

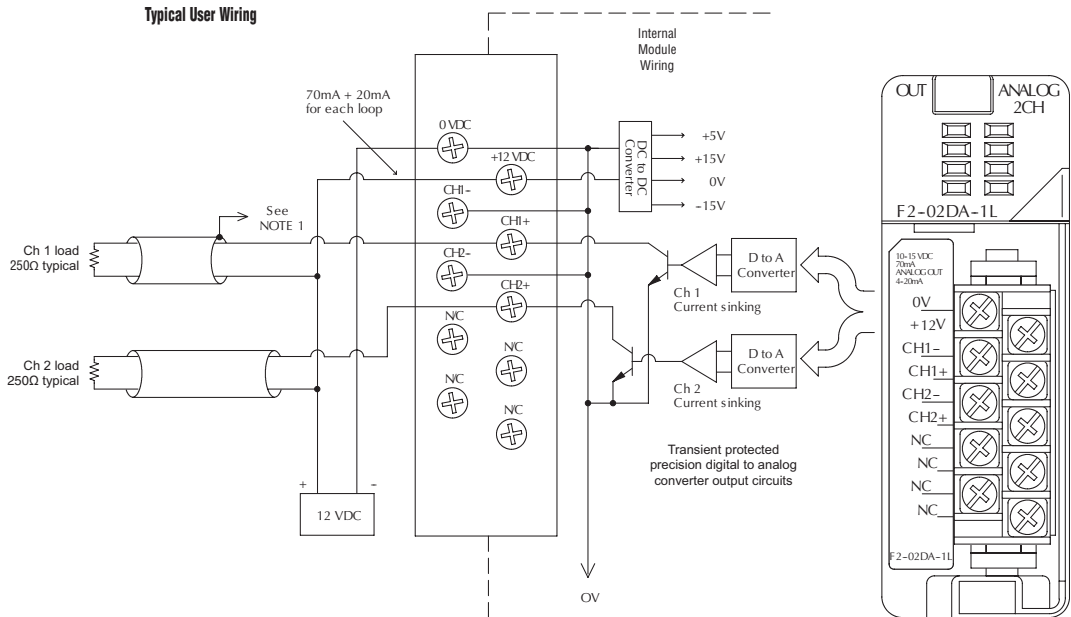

NOTE 1: Shields should be connected to the 0V of the module or the 0V of the P/S.

NOTE 2: Unused current outputs should remain open (no connections) for minimum power consumption.

Maximum user load is dependent upon loop power supply.

Loop power supply	Load range (ohm)
15 VDC	0 to 450
12 VDC	0 to 300
10 VDC	0 to 200

F2-02DAS-1 2-Channel Isolated 4-20mA Analog Output Module

Number of Channels	2, isolated
Output Ranges	4 to 20 mA
Resolution	16 bit (1 in 65536)
Output Type	Current sourcing
Digital Output Points Required	32 (Y) output points (16 binary data bits, 2 channel ID bits, 1 output enable bit)
Isolation Voltage	±750 V continuous, channel to channel, channel to logic
Base Power Required 5VDC	100mA
Loop Supply	18-32 VDC
External Power Supply	18-32 VDC @ 50 mA per channel
Output Loop Compliance	Vin - 2.5V
Load Impedance	0-1375 Ω (@ 32 V)
Maximum Load/ Power Supply	375 Ω/12 V, 975 Ω/24 V, 1375 Ω/32 V
PLC Update Rate	1 channel per scan maximum (D2-230 CPU) 2 channels per scan maximum (D2-240, D2-250(-1) and D2-260 CPUs)
Conversion Settling Time	3ms to 0.1% of full scale

Linearity Error (end to end)	±10 count (±0.015% of full scale) maximum
Gain Calibration Error	±32 counts (±0.05%)
Offset Calibration Error	±13 counts (±0.02%)
Output Drift	50 ppm/°C
Maximum Inaccuracy	0.07% @ 25°C (77°F) 0.18% 0 to 60°C (32° to 140°F)
Operating Temperature	0° to 60°C (32° to 140°F)
Storage Temperature	-20° to 70°C (-4° to 158°F)
Relative Humidity	5 to 95% (non-condensing)
Environmental air	No corrosive gases permitted
Shock & Vibration	MIL STD 810C 514.2
Noise Immunity	NEMA ICS3-304
Terminal Type (included)	Removable; D2-8IOCON

One count in the specification table is equal to one least significant bit of the analog data value (1 in 65536).

F2-02DAS-1 2-Channel Isolated 4-20mA Analog Output

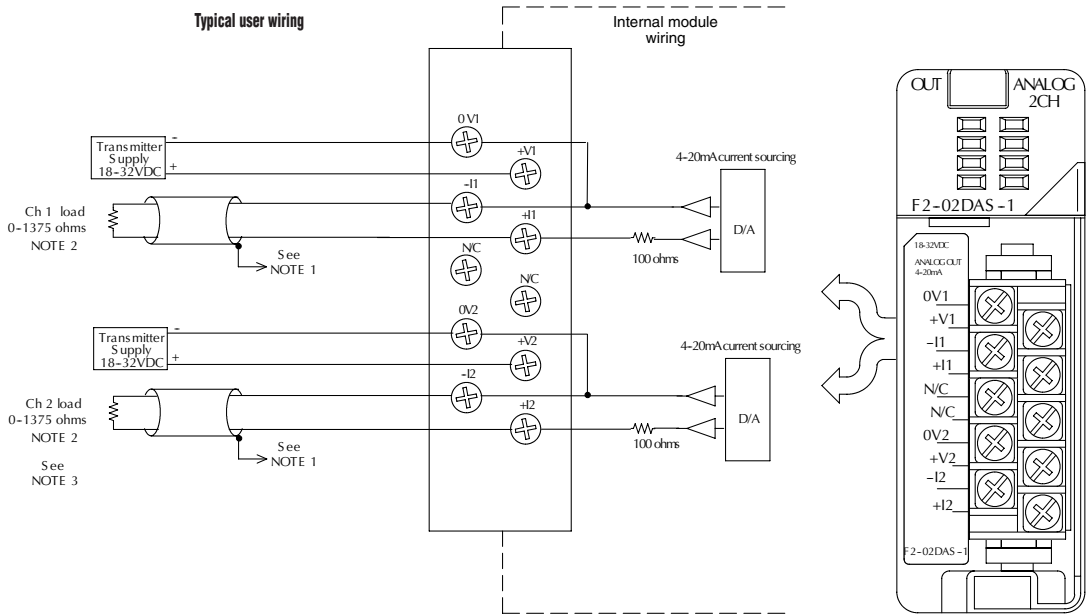

NOTE 1: Shields should be connected to the 0V terminal of the module.

NOTE 2: Load must be within compliance voltage.

NOTE 3: For non-isolated outputs, connect all 0V's together (0V1...0V2) and connect all +V's together (+V1...+V2).

F2-08DA-1 8-Channel 4-20mA Analog Output Module

Number of Channels	8, single-ended
Output Ranges	4 to 20 mA
Resolution	12 bit (1 in 4096)
Output Type	Current sinking or current sourcing
Digital Output Points Required	16 (Y) output points (12 binary data bits, 3 channel ID bits, 1 output enable bit)
Base Power Required 5VDC	30mA
Maximum Loop Voltage	30VDC
External Power Supply	18 to 30 VDC, 50 mA., class 2 (add 20 mA for each current loop used)
Source Load	0-400 Ω @ 18-30 VDC
Sink Load	0-600 Ω /18V, 0-900 Ω /24 V, 0-1200 Ω /30 V
Total Load (sink + source)	600 Ω /18 V, 900 Ω /24 V, 1200 Ω /30 V
PLC Update Rate	1 channel per scan maximum (D2-230 CPU) 8 channels per scan maximum (D2-240, D2-250(-1) and D2-260 CPUs)
Conversion Settling Time	400 μ s maximum (full scale change)

Linearity Error (end to end)	± 2 count ($\pm 0.050\%$ of full scale) maximum
Full Scale Calibration Error	± 12 counts max. sinking @ any load ± 12 counts max. sourcing @ 125 Ω load ± 18 counts max. sourcing @ 250 Ω load ± 26 counts max. sourcing @ 400 Ω load
Offset Calibration Error	± 9 counts max. sinking @ any load ± 9 counts max. sourcing @ 125 Ω load ± 11 counts max. sourcing @ 250 Ω load ± 13 counts max. sourcing @ 400 Ω load
Maximum Full Scale Inaccuracy @ 60°C	0.5% sinking (any load) sinking & sourcing @ 125 Ω load 0.64% sourcing @ 250 Ω load 0.83% sourcing @ 400 Ω load
Maximum Full Scale Inaccuracy @ 25°C (Includes all errors and temp drift)	0.3% sinking (any load) sinking & sourcing @ 125 Ω load 0.44% sourcing @ 250 Ω load 0.63% sourcing @ 400 Ω load
Operating Temperature	32° to 140°F (0° to 60°C)
Storage Temperature	-4 to 158°F (-20 to 70°C)
Relative Humidity	5% to 95% (non-condensing)
Environmental air	No corrosive gases permitted
Shock & Vibration	MIL STD 810C 514.2
Noise Immunity	NEMA ICS3-304
Terminal Type (included)	Removable; D2-16IOCON

F2-08DA-1 8-Channel 4-20mA Analog Output

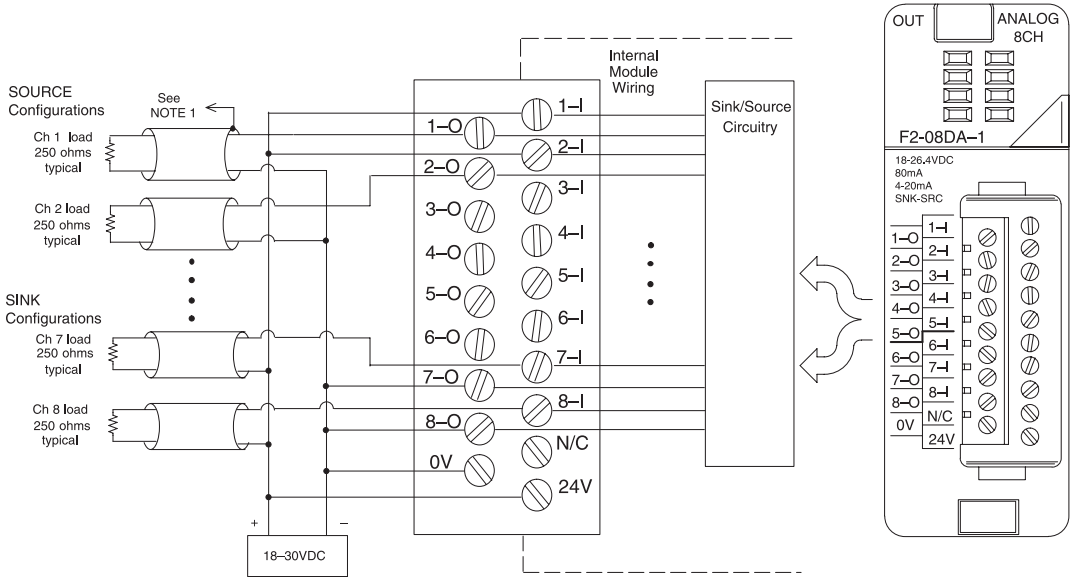

NOTE 1: Shields should be connected to the 0V of the module.

F2-02DA-2 2-Channel Voltage Analog Output Module

This module requires a 24VDC user power supply for operation. See the F2-02DA-2L on the next page if you want to use a 12VDC supply. All other specifications are the same.	
Number of Channels	2
Output Ranges	0 to 5V, 0 to 10 V, $\pm 5V$, $\pm 10 V$
Resolution	12 bit (1 in 4096)
Output Type	Single ended, 1 common
Digital Output Points Required	16 (Y) output points (12 binary data bits, 2 channel ID bits)
Peak Output Voltage	15VDC (clamped by transient voltage suppressor)
Load Impedance	2000 Ω minimum
Load Capacitance	0.01 μF maximum
PLC Update Rate	1 channel per scan maximum D2-230 CPU 2 channels per scan maximum (D2-240, D2-250(-1) and D2-260 CPUs)
Linearity Error (end to end)	± 1 count (0.025% of full scale) maximum
Conversion Settling Time	5 μs maximum (full scale change)
Full Scale Calibration Error (offset error included)	± 12 counts max. unipolar @ 77°F (25°C) ± 16 counts max. bipolar @ 77°F (25°C)
Offset Calibration Error	± 3 counts max., unipolar @ 77°F (25°C) ± 8 counts max., bipolar @ 77°F (25°C)

Accuracy vs. Temperature	± 50 ppm/°C full scale calibration change (including maximum offset change of 2 counts)
Maximum Inaccuracy	+0.3% unipolar ranges @ 77°F (25°C) $\pm 0.45\%$ unipolar ranges >77°F (25°C) $\pm 0.4\%$ bipolar ranges @ 77°F (25°C) $\pm 0.55\%$ bipolar ranges >77°F (25°C)
Base Power Required 5VDC	40mA
External Power Supply	18 to 30 VDC, 60mA (outputs fully loaded)
Operating Temperature	32° to 140°F (0° to 60°C)
Storage Temperature	-4° to 158°F (-20° to 70°C)
Relative Humidity	5 to 95% (non-condensing)
Environmental Air	No corrosive gases permitted
Shock & Vibration	MIL STD 810C 514.2
Noise Immunity	NEMA ICS3-304
Terminal Type (included)	Removable; D2-8IOCON

One count in the specification table is equal to one least significant bit of the analog data value (1 in 4096).

F2-02DA-2 2-Channel Voltage Analog Output

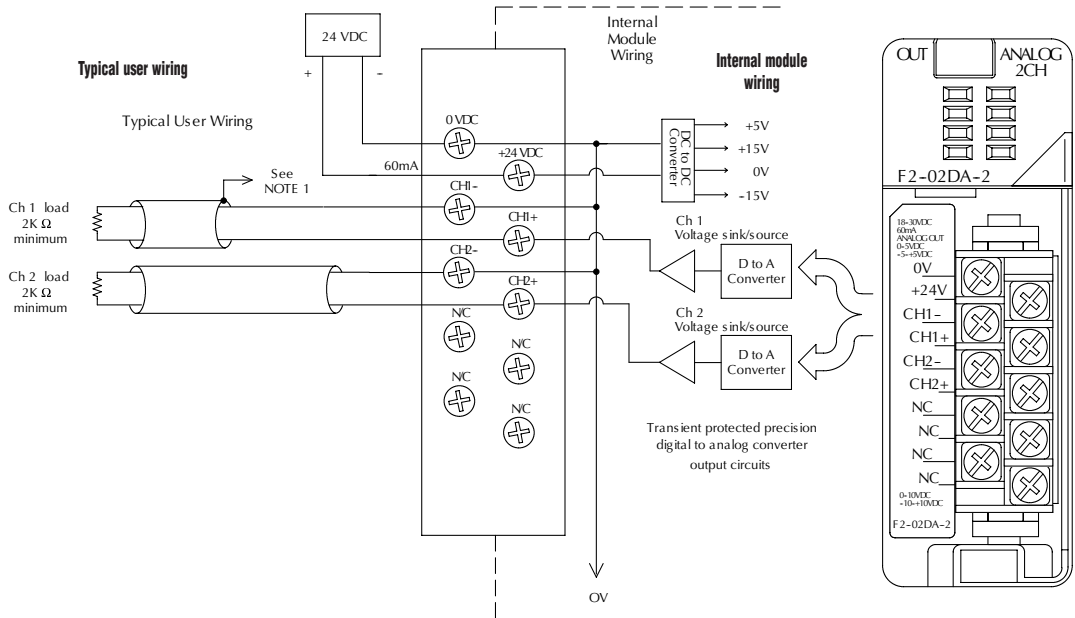

NOTE 1: Shields should be connected to the 0V of the module or the 0V of the R/S.

NOTE 2: Unused voltage outputs should remain open (no connections) for minimum power consumption.

F2-02DA-2L 2-Channel Voltage Analog Output Module

This module requires a 12 VDC user power supply for operation. See the F2-02DA-2 on the previous page if you want to use a 24 VDC supply. All other specifications are the same.	
Number of Channels	2
Output Ranges	0 to 5V, 0 to 10 V, $\pm 5V$, $\pm 10 V$
Resolution	12-bit (1 in 4096)
Output Type	Single ended, 1 common
Digital Output Points Required	16 (Y) output points (12 binary data bits, 2 channel ID bits)
Peak Output Voltage	15VDC (clamped by transient voltage suppressor)
Load Impedance	2000 Ω minimum
Load Capacitance	.01 μF maximum
PLC Update Rate	1 channel per scan maximum (D2-230 CPU) 2 channels per scan maximum (D2-240, D2-250(-1), D2-260, and D2-262 CPUs)
Linearity Error (end to end)	± 1 count (0.025% of full scale) maximum
Conversion Settling Time	5 μs maximum (full scale change)
Full Scale Calibration Error (offset error included)	± 12 counts max. unipolar @ 77°F (25°C) ± 16 counts max. bipolar @ 77°F (25°C)
Offset Calibration Error	± 3 counts max., unipolar @ 77°F (25°C) ± 8 counts max., bipolar @ 77°F (25°C)

Accuracy vs. Temperature	± 50 ppm/°C full scale calibration change (including maximum offset change of 2 counts)
Maximum Inaccuracy	+0.3% unipolar ranges @ 77°F (25°C) $\pm 0.45\%$ unipolar ranges >77°F (25°C) $\pm 0.4\%$ bipolar ranges @77°F (25°C) $\pm 0.55\%$ bipolar ranges >77°F (25°C)
Base Power Required 5VDC	40mA
External Power Supply	10 to 15 VDC, 70 mA (outputs fully loaded)
Operating Temperature	32° to 140°F (0° to 60°C)
Storage Temperature	-4° to 158°F (-20° to 70°C)
Relative Humidity	5 to 95% (non-condensing)
Environmental Air	No corrosive gases permitted
Shock & Vibration	MIL STD 810C 514.2
Noise Immunity	NEMA ICS3-304
Terminal Type (included)	Removable; D2-8IOCON

One count in the specification table is equal to one least significant bit of the analog data value (1 in 4096).

F2-02DA-2L 2-Channel Voltage Analog Output

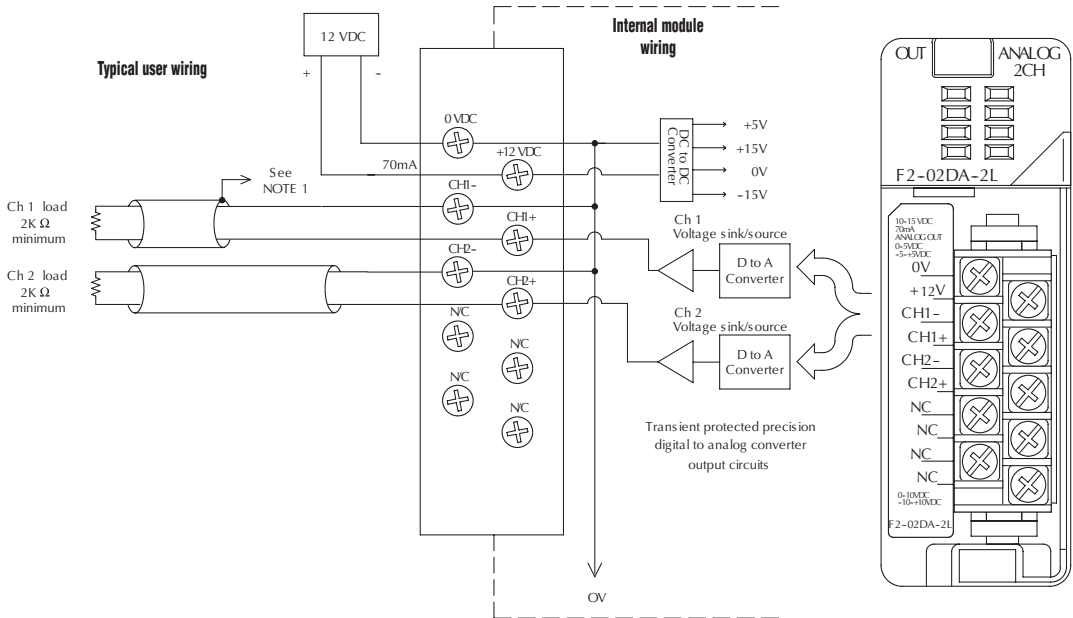

NOTE 1: Shields should be connected to the 0V of the module or the 0V of the P/S.

NOTE 2: Unused voltage outputs should remain open (no connections) for minimum power consumption.

F2-02DAS-2 2-Channel 0-5 V, 0-10 V Isolated Analog Output Module

Number of Channels	2, isolated
Output Ranges	0-5 V, 0-10 V
Resolution	16 bit (1 in 65536)
Output Type	Sourced through external loop supply
Digital Output Points Required	32 (Y) output points (16 binary data bits, 2 channel ID bits)
Isolation Voltage	±750V continuous, channel to channel, channel to logic
Base Power Required 5VDC	60mA
External Power Supply	21.6-26.4 VDC @ 60 mA per channel
Load Impedance	2kΩ min
PLC Update Rate	1 channel per scan maximum (D2-230 CPU) 2 channels per scan maximum (D2-240, D2-250(-1), D2-260, and D2-262 CPUs)
Conversion Settling Time	3ms to 0.1% of full scale

Linearity Error (end to end)	±10 count (±0.015% of full scale) maximum
Gain Calibration Error	±32 counts (±0.05%)
Offset Calibration Error	±13 counts (±0.02%)
Output Drift	50 ppm/°C
Maximum Inaccuracy	0.07% @ 25°C (77°F) 0.18% 0 to 60°C (32° to 140°F)
Operating Temperature	0° to 60°C (32° to 140°F)
Storage Temperature	-20° to 70°C (-4° to 158°F)
Relative Humidity	5 to 95% (non-condensing)
Environmental air	No corrosive gases permitted
Shock & Vibration	MIL STD 810C 514.2
Noise Immunity	NEMA ICS3-304
Terminal Type (included)	Removable; D2-8IOCON

F2-02DAS-2 2-Channel 0-5V, 0-10V Isolated Analog Output

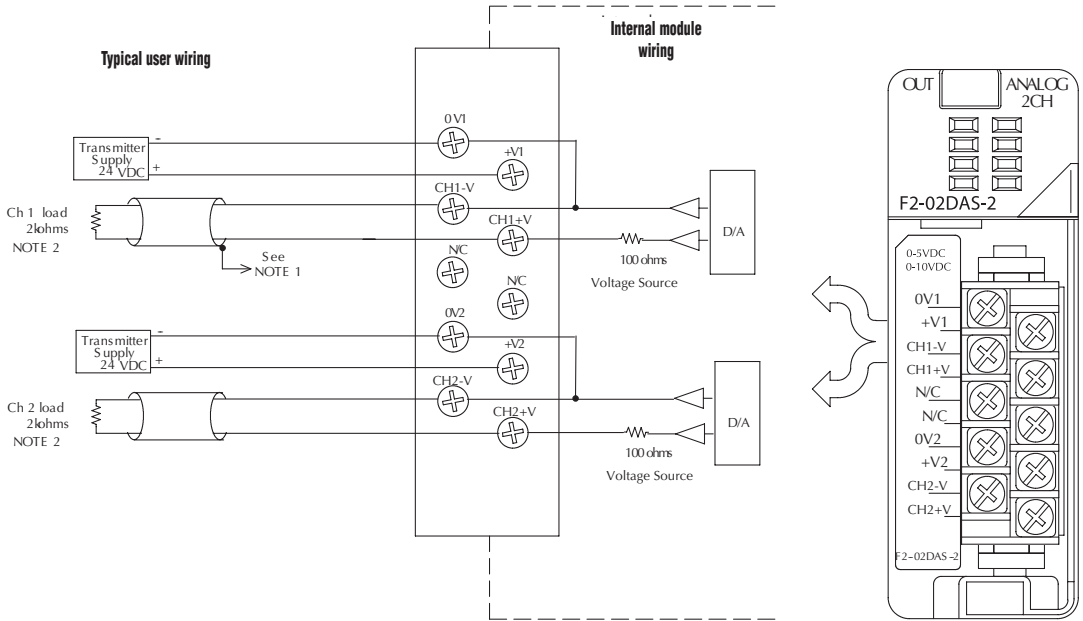

NOTE 1: Shields should be connected to the 0V of the module or the 0V of the P/S.
NOTE 2: Unused voltage outputs should remain open (no connections) for minimum power consumption.

F2-08DA-2 8-Channel Voltage Analog Output Module

Number of Channels	8, single-ended, 1 common
Output Ranges	0 to 5V, 0 to 10V
Resolution	12 bit (1 in 4096)
Output Type	Voltage sourcing
Digital Output Points Required	16 (Y) output points (12 binary data bits, 3 channel ID bits, 1 output enable bit)
Base Power Required 5VDC	60mA
External Power Supply	21.6-26.4 VDC, 140 mA (outputs fully loaded)
Peak Output Voltage	15 VDC (clamped by transient voltage suppressor)
Load Impedance	1-10 k Ω
Load Capacitance	0.01 μ F maximum
PLC Update Rate	1 channel per scan maximum (D2-230 CPU) 8 channels per scan maximum (D2-240, D2-250(-1) and D2-260 CPUs)
Conversion Settling Time	400 μ s maximum (full scale change) 4.5 ms to 9ms for digital out to analog out

Linearity Error (end to end)	± 1 count ($\pm 0.025\%$ of full scale) maximum
Full Scale Calibration Error	± 12 counts max. unipolar @ 25°C (77°F)
Offset Calibration Error	± 3 counts max., unipolar @ 25°C (77°F)
Accuracy vs. Temperature	± 57 ppm/°C full scale calibration change (including maximum offset change of 2 counts)
Maximum Inaccuracy	$\pm 0.3\%$ @ 25°C (77°F) $\pm 0.45\%$ @ 0-60°C (32-140°F)
Operating Temperature	0° to 60°C (32° to 140°F)
Storage Temperature	-20° to 70°C (-4° to 158°F)
Relative Humidity	5 to 95% (non-condensing)
Environmental air	No corrosive gases permitted
Shock & Vibration	MIL STD 810C 514.2
Noise Immunity	NEMA ICS3-304
Terminal Type (included)	Removable; D2-8IOCON

One count in the specification table is equal to one least significant bit of the analog data value (1 in 4096).

F2-08DA-2 8-Channel Voltage Analog Output

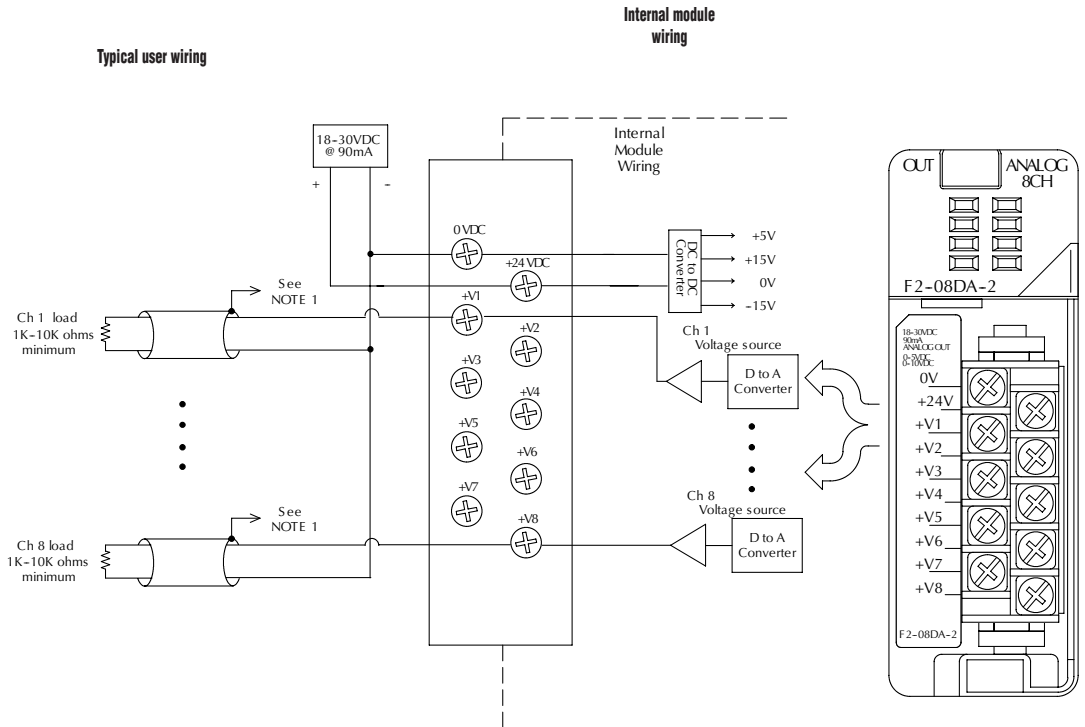

NOTE 1: Shields should be connected to the 0V of the module.

DL205 Combination Analog I/O Modules

F2-04AD2DA 4-Channel Analog Input / 2-Channel Analog Output Module

Number of Input Channels	4, single-ended (1 common)
Number of Output Channels	2, single-ended (1 common)
Ranges	4 to 20 mA current (current sinking)
Resolution	12 bit (1 in 4096)
Peak Withstanding Voltage	75VDC, current outputs
Max. Continuous Overload	-40 to +40 mA, each current output
Input Impedance	250 Ω , \pm 0.1%, 1/2 W, 25 ppm/ $^{\circ}$ C current input resistance
External Load Resistance	0 Ω minimum, current outputs
Maximum Loop Supply	30VDC
Recommended Fuse	0.032 A, series 217 fast-acting, current inputs
Maximum Load/Power Supply	910 Ω /24V, current outputs 620 Ω /18V, 1200 Ω /30V
Active Low-pass Filter	-3 dB @ 20 Hz, 2 poles (-12 dB per octave)
Linearity Error (best fit)	\pm 1 count (\pm 0.025% of full scale) maximum
Output Settling Time	100 μ s maximum (full scale change)

Accuracy vs. Temperature	\pm 50 ppm/ $^{\circ}$ C full scale calibration change (including maximum offset change)
Maximum Inaccuracy	\pm 0.1% @ 77 $^{\circ}$ F (25 $^{\circ}$ C) \pm 0.3% @ 32 to 140 $^{\circ}$ F (0 to 60 $^{\circ}$ C)
Digital Input and Output Points Required	16 (X) input points (12 binary data bits, 2 channel ID bits, 2 diagnostic bits) 16 (Y) output points (12 binary data bits, 2 channel enable bits)
PLC Update Rate	4 channels per scan maximum: (D2-240, D2-250(-1) and D2-260 CPUs) 2 output channels per scan maximum: (D2-240, D2-250(-1) and D2-260 CPUs) 1 input and 1 output channel per scan maximum: (D2-230 CPU)
Base Power Required 5VDC	90mA
External Power Supply Requirement	18-26.4 VDC @ 80mA 20mA per loop
Operating Temperature	32 $^{\circ}$ to 140 $^{\circ}$ F (0 $^{\circ}$ to 60 $^{\circ}$ C)
Storage Temperature	-4 $^{\circ}$ to 158 $^{\circ}$ F (-20 $^{\circ}$ to 70 $^{\circ}$ C)
Relative Humidity	5 to 95% (non-condensing)
Environmental Air	No corrosive gases permitted
Shock & Vibration	MIL STD 810C 514.2
Noise Immunity	NEMA ICS3-304
Terminal Type (included)	Removable; D2-8IOCON

One count in the specification table is equal to one least significant bit of the analog data value (1 in 4096).

F2-04AD2DA 4-Channel Analog Input / 2-Channel Analog Output Module

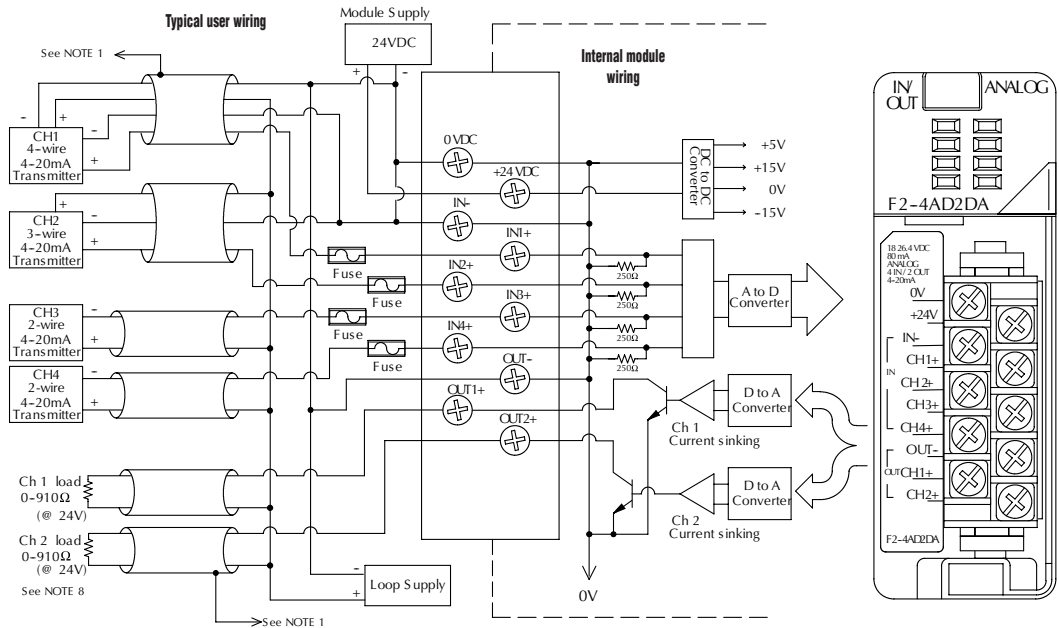

Note 1: Shields should be connected at their respective signal source.

Note 2: Unused channel should remain open for minimum power consumption.

Note 3: More than one external power supply can be used provided the power supply commons are connected.

Note 4: A Series 217, 0.032A fast-acting fuse is recommended for 4-20 mA current input loops.

Note 5: If the power supply common of an external power supply is not connected to 0 VDC on the module, then the output of the external transmitter must be isolated. To avoid "ground loop" errors, recommended 4-20 mA transmitter types are:
 2 or 3 wire: isolation between Input signal and power supply
 4 wire: Isolation between input signal, power supply, and 4-20 mA output.

Note 6: If an analog channel is connected backwards, then erroneous data values will be returned for that channel.

Note 7: To avoid small errors due to terminal block losses, connect 0 VDC, IN-, and OUT- on the terminal block as shown. The module's internal connection alone of these nodes is not sufficient to permit module performance up to the accuracy specifications.

Note 8: Choose an output transducer resistance according to the maximum load/power listed in the Output Specifications.

F2-08AD4DA-1 8-Channel Analog Current Input / 4-Channel Analog Current Output Module

NOT SUPPORTED BY D2-230 AND D2-240 CPUs.

Input Channels per Module	8, single ended (one common)
Input Range	0 to 20 mA
Resolution	12, 14, 16-bit selectable
External DC Power Required	100mA @ 18-26.4 VDC
Max. Continuous Overload	±45mA
Input Impedance	100 Ω 0.1% 1/4W
Filter Characteristics	Active low pass, -3dB @ 80 Hz
Conversion Time	12-bit = 1.5 ms per channel 14-bit = 6 ms per channel 16-bit = 25 ms per channel
Conversion Method	Over sampling successive approximation
Accuracy vs. Temperature	±25 ppm / °C Max.
Maximum Inaccuracy	0.1% of range
Linearity Error (End to End)	12-bit = ±2 count max. (±0.06% of range) 14-bit = ±10 count max. (±0.06% of range) 16-bit = ±20 count max. (±0.06% of range) Monotonic with no missing codes
Full Scale Calibration Error (not including offset error)	±0.07% of range max.
Offset Calibration Error	±0.03% of range max.
Rec. Fuse (external)	0.032 A, Littelfuse Series 217 fast-acting
Base Power Required 5VDC	35mA

Output Channels per Module	4
Output Range	4 to 20 mA
Resolution	16-bit, 0.244 mA/bit
Output Type	Current sourcing at 20 mA max.
Load Impedance	0-750 Ω
Max. Inaccuracy	0.25% of range
Max. Full Scale Calibration Error (not incl. offset error)	±0.075% of range max.
Max. Offset Calibration Error	±0.1% of range max.
Accuracy vs. Temperature	±25 ppm/ °C max. full scale calibration change (± 0.0025% of range / °C)
Max. Crosstalk at DC, 50/60Hz	-70 dB, 1 LSB

F2-08AD4DA-1 8-Channel Analog Current Input / 4-Channel Analog Current Output

Linearity Error (End to End)	±1 count max. (±0.025% of full scale) Monotonic with no missing codes
Output Stability and Repeatability	±1 LSB after 10 min. warm-up typical
Output Ripple	0.005% of full scale
Output Settling Time	0.5 ms max., 5µs min. (full scale change)
Max. Continuous Overload	Outputs open circuit protected
Type of Output Protection	Electronically current limited to 20mA or less
Output Signal at Power-up and Power-down	4mA
Terminal Type (included)	Removable; D2-16IOCON

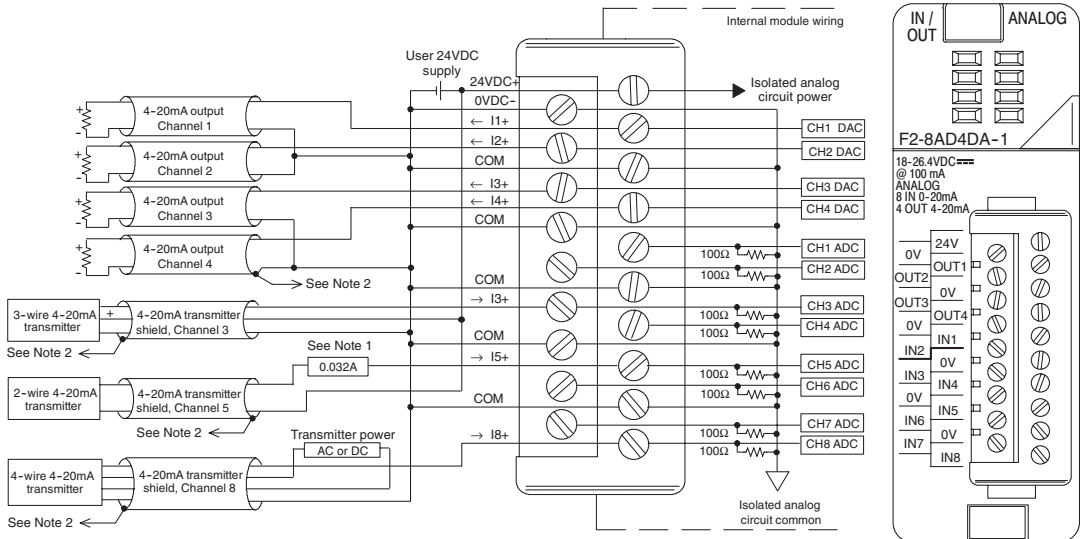

Note 1: A Littelfuse Series 217, 0.032A fast-acting fuse is recommended for all 4-20mA current loop inputs.

Note 2: Connect shields to the 0V of the module; do not connect both ends of shield.

F2-08AD4DA-2 8-Channel Analog Voltage Input / 4-Channel Analog Voltage Output Module

Input Channels per Module	8, single ended (one common)
Input Range	0 to 10 V
Resolution	12, 14, 16-bit selectable
External DC Power Required	80mA @ 18-26.4 VDC
Max. Continuous Overload	±100 V
Input Impedance	>10MΩ
Filter Characteristics	Active low pass, -3 dB @ 80Hz
Conversion Time	12-bit = 1.5 ms per channel 14-bit = 6 ms per channel 16-bit = 25 ms per channel
Conversion Method	Over sampling successive approximation
Accuracy vs. Temperature	±50 ppm / °C Max.
Maximum Inaccuracy	0.1% of range
Linearity Error (End to End)	12-bit = ±1 count max. (±0.025% of range) 14-bit = ±4 count max. (±0.025% of range) 16-bit = ±16 count max. (±0.025% of range) Monotonic with no missing codes
Full Scale Calibration Error (not including offset error)	±0.075% of range max.
Offset Calibration Error	±0.025% of range max.
Base Power Required 5VDC	35mA

Output Channels per Module	4
Output Range	0–5 V, 0–10 V
Resolution	0 to 5 V at 15-bit, 0 to 10 V at 16-bit, 152μV/bit
Output Type	Voltage sourcing/sinking at 10mA max.
Load Impedance	>1000 Ω
Max. Inaccuracy	0.15% of range
Max. Full Scale Calibration Error (not incl. offset error)	±0.075% of range max.
Max. Offset Calibration Error	±0.025% of range max.
Accuracy vs. Temperature	±50 ppm/ °C max. full scale calibration change (± 0.005% of range / °C)
Max. Crosstalk @ DC, 50/60Hz	-70 dB, 1 LSB

F2-08AD4DA-2 8-Channel Analog Voltage Input / 4-Channel Analog Voltage Output

Linearity Error (End to End)	±1 count max. (±0.025% of full scale) Monotonic with no missing codes
Output Stability and Repeatability	±1 LSB after 10 min. warm-up typical
Output Ripple	0.005% of full scale
Output Settling Time	0.5 ms max., 5µs min. (full scale change)
Max. Continuous Overload	Outputs current limited to 15mA typical
Type of Output Protection	1VDC peak output voltage (clamped by transient voltage suppressor)
Output Signal at Power-up and Power-down	0V
Terminal Type (included)	Removable; D2-16IOCON

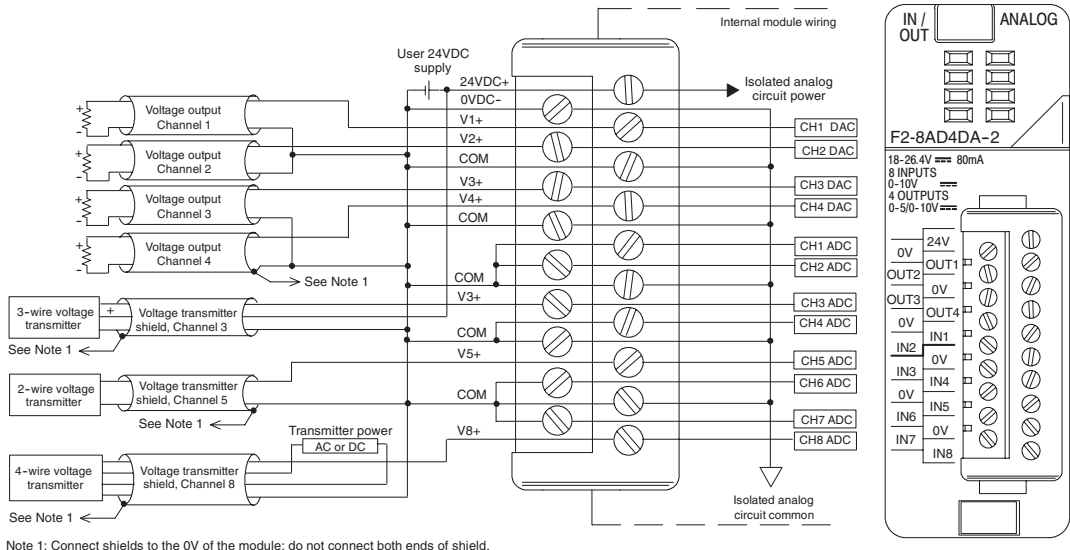

Glossary of Specification Terms

Inputs or Outputs Per Module

Indicates number of input or output points per module and designates current sinking, current sourcing, or either.

Commons Per Module

Number of commons per module and their electrical characteristics.

Input Voltage Range

The operating voltage range of the input circuit.

Output Voltage Range

The operating voltage range of the output circuit.

Peak Voltage

Maximum voltage allowed for the input circuit.

AC Frequency

AC modules are designed to operate within a specific frequency range.

ON Voltage Level

The voltage level at which the input point will turn ON.

OFF Voltage Level

The voltage level at which the input point will turn OFF.

Input impedance

Input impedance can be used to calculate input current for a particular operating voltage.

Input Current

Typical operating current for an active (ON) input.

Minimum ON Current

The minimum current for the input circuit to operate reliably in the ON state.

Maximum OFF Current

The maximum current for the input circuit to operate reliably in the OFF state.

Minimum Load

The minimum load current for the output circuit to operate properly.

External DC Required

Some output modules require external power for the output circuitry.

ON Voltage Drop

Sometimes called “saturation voltage”, it is the voltage measured from an output point to its common terminal when the output is ON at max. load.

Maximum Leakage Current

The maximum current a connected maximum load will receive when the output point is OFF.

Maximum Inrush Current

The maximum current used by a load for a short duration upon an OFF to ON transition of a output point. It is greater than the normal ON state current and is characteristic of inductive loads in AC circuits.

Base Power Required

Power from the base power supply is used by the DL205 input modules and varies between different modules. The guidelines for using module power is explained in the power budget configuration section in Chapter 4–7.

OFF to ON Response

The time the module requires to process an OFF to ON state transition.

ON to OFF Response

The time the module requires to process an ON to OFF state transition.

Terminal Type

Indicates whether the terminal type is a removable or non-removable connector or a terminal.

Status Indicators

The LEDs that indicate the ON/OFF status of an input point. These LEDs are electrically located on either the logic side or the field device side of the input circuit.

Fuses

Protective devices for an output circuit, which stop current flow when current exceeds the fuse rating. They may be replaceable or non-replaceable, or located externally or internally.