



Manual Number: C2-USER-M

⚡ WARNING ⚡

Thank you for purchasing automation equipment from **AutomationDirect.com**[®], doing business as, **AutomationDirect**. We want your new automation equipment to operate safely. Anyone who installs or uses this equipment should read this publication (and any other relevant publications) before installing or operating the equipment.

To minimize the risk of potential safety problems, you should follow all applicable local and national codes that regulate the installation and operation of your equipment. These codes vary from area to area and usually change with time. It is your responsibility to determine which codes should be followed, and to verify that the equipment, installation, and operation is in compliance with the latest revision of these codes.

At a minimum, you should follow all applicable sections of the National Fire Code, National Electrical Code, and the codes of the National Electrical Manufacturer's Association (NEMA). There may be local regulatory or government offices that can also help determine which codes and standards are necessary for safe installation and operation.

Equipment damage or serious injury to personnel can result from the failure to follow all applicable codes and standards. We do not guarantee the products described in this publication are suitable for your particular application, nor do we assume any responsibility for your product design, installation, or operation.

Our products are not fault-tolerant and are not designed, manufactured or intended for use or resale as on-line control equipment in hazardous environments requiring fail-safe performance, such as in the operation of nuclear facilities, aircraft navigation or communication systems, air traffic control, direct life support machines, or weapons systems, in which the failure of the product could lead directly to death, personal injury, or severe physical or environmental damage ("High Risk Activities"). **AutomationDirect** specifically disclaims any expressed or implied warranty of fitness for High Risk Activities.

For additional warranty and safety information, see the Terms and Conditions section of our catalog. If you have any questions concerning the installation or operation of this equipment, or if you need additional information, please call us at 770-844-4200.

This publication is based on information that was available at the time it was printed. At **AutomationDirect** we constantly strive to improve our products and services, so we reserve the right to make changes to the products and/or publications at any time without notice and without any obligation. This publication may also discuss features that may not be available in certain revisions of the product.

Trademarks

This publication may contain references to products produced and/or offered by other companies. The product and company names may be trademarked and are the sole property of their respective owners. **AutomationDirect** disclaims any proprietary interest in the marks and names of others.

Copyright 2021-2025, **AutomationDirect.com**[®] Incorporated
All Rights Reserved

No part of this manual shall be copied, reproduced, or transmitted in any way without the prior, written consent of **AutomationDirect.com**[®] Incorporated. **AutomationDirect** retains the exclusive rights to all information included in this document.

⚡ ADVERTENCIA ⚡

Gracias por comprar equipo de automatización de **Automationdirect.com**[®]. Deseamos que su nuevo equipo de automatización opere de manera segura. Cualquier persona que instale o use este equipo debe leer esta publicación (y cualquier otra publicación pertinente) antes de instalar u operar el equipo.

Para reducir al mínimo el riesgo debido a problemas de seguridad, debe seguir todos los códigos de seguridad locales o nacionales aplicables que regulan la instalación y operación de su equipo. Estos códigos varían de área en área y usualmente cambian con el tiempo. Es su responsabilidad determinar cuales códigos deben ser seguidos y verificar que el equipo, instalación y operación estén en cumplimiento con la revisión más reciente de estos códigos.

Como mínimo, debe seguir las secciones aplicables del Código Nacional de Incendio, Código Nacional Eléctrico, y los códigos de (NEMA) la Asociación Nacional de Fabricantes Eléctricos de USA. Puede haber oficinas de normas locales o del gobierno que pueden ayudar a determinar cuales códigos y normas son necesarios para una instalación y operación segura.

Si no se siguen todos los códigos y normas aplicables, puede resultar en daños al equipo o lesiones serias a personas. No garantizamos los productos descritos en esta publicación para ser adecuados para su aplicación en particular, ni asumimos ninguna responsabilidad por el diseño de su producto, la instalación u operación.

Nuestros productos no son tolerantes a fallas y no han sido diseñados, fabricados o intencionados para uso o reventa como equipo de control en línea en ambientes peligrosos que requieren una ejecución sin fallas, tales como operación en instalaciones nucleares, sistemas de navegación aérea, o de comunicación, control de tráfico aéreo, máquinas de soporte de vida o sistemas de armamentos en las cuales la falla del producto puede resultar directamente en muerte, heridas personales, o daños físicos o ambientales severos (“Actividades de Alto Riesgo”). **Automationdirect.com** específicamente rechaza cualquier garantía ya sea expresada o implicada para actividades de alto riesgo.

Para información adicional acerca de garantía e información de seguridad, vea la sección de Términos y Condiciones de nuestro catálogo. Si tiene alguna pregunta sobre instalación u operación de este equipo, o si necesita información adicional, por favor llámenos al número 770-844-4200 en Estados Unidos.

Esta publicación está basada en la información disponible al momento de impresión. En **Automationdirect.com** nos esforzamos constantemente para mejorar nuestros productos y servicios, así que nos reservamos el derecho de hacer cambios al producto y/o a las publicaciones en cualquier momento sin notificación y sin ninguna obligación. Esta publicación también puede discutir características que no estén disponibles en ciertas revisiones del producto.

Marcas Registradas

Esta publicación puede contener referencias a productos producidos y/u ofrecidos por otras compañías. Los nombres de las compañías y productos pueden tener marcas registradas y son propiedad única de sus respectivos dueños. **Automationdirect.com**, renuncia cualquier interés propietario en las marcas y nombres de otros.

PROPIEDAD LITERARIA 2021-2025, AUTOMATIONDIRECT.COM[®] INCORPORATED
Todos los derechos reservados

No se permite copiar, reproducir, o transmitir de ninguna forma ninguna parte de este manual sin previo consentimiento por escrito de **Automationdirect.com[®] Incorporated**. **Automationdirect.com** retiene los derechos exclusivos a toda la información incluida en este documento. Los usuarios de este equipo pueden copiar este documento solamente para instalar, configurar y mantener el equipo correspondiente. También las instituciones de enseñanza pueden usar este manual para propósitos educativos.

⚡ AVERTISSEMENT ⚡

Nous vous remercions d'avoir acheté l'équipement d'automatisation de **Automationdirect.com**[®], en faisant des affaires comme, **AutomationDirect**. Nous tenons à ce que votre nouvel équipement d'automatisation fonctionne en toute sécurité. Toute personne qui installe ou utilise cet équipement doit lire la présente publication (et toutes les autres publications pertinentes) avant de l'installer ou de l'utiliser.

Afin de réduire au minimum le risque d'éventuels problèmes de sécurité, vous devez respecter tous les codes locaux et nationaux applicables régissant l'installation et le fonctionnement de votre équipement. Ces codes diffèrent d'une région à l'autre et, habituellement, évoluent au fil du temps. Il vous incombe de déterminer les codes à respecter et de vous assurer que l'équipement, l'installation et le fonctionnement sont conformes aux exigences de la version la plus récente de ces codes.

Vous devez, à tout le moins, respecter toutes les sections applicables du Code national de prévention des incendies, du Code national de l'électricité et des codes de la National Electrical Manufacturer's Association (NEMA). Des organismes de réglementation ou des services gouvernementaux locaux peuvent également vous aider à déterminer les codes ainsi que les normes à respecter pour assurer une installation et un fonctionnement sûrs.

L'omission de respecter la totalité des codes et des normes applicables peut entraîner des dommages à l'équipement ou causer de graves blessures au personnel. Nous ne garantissons pas que les produits décrits dans cette publication conviennent à votre application particulière et nous n'assumons aucune responsabilité à l'égard de la conception, de l'installation ou du fonctionnement de votre produit.

Nos produits ne sont pas insensibles aux défaillances et ne sont ni conçus ni fabriqués pour l'utilisation ou la revente en tant qu'équipement de commande en ligne dans des environnements dangereux nécessitant une sécurité absolue, par exemple, l'exploitation d'installations nucléaires, les systèmes de navigation aérienne ou de communication, le contrôle de la circulation aérienne, les équipements de survie ou les systèmes d'armes, pour lesquels la défaillance du produit peut provoquer la mort, des blessures corporelles ou de graves dommages matériels ou environnementaux («activités à risque élevé»). La société **AutomationDirect** nie toute garantie expresse ou implicite d'aptitude à l'emploi en ce qui a trait aux activités à risque élevé.

Pour des renseignements additionnels touchant la garantie et la sécurité, veuillez consulter la section Modalités et conditions de notre documentation. Si vous avez des questions au sujet de l'installation ou du fonctionnement de cet équipement, ou encore si vous avez besoin de renseignements supplémentaires, n'hésitez pas à nous téléphoner au 770-844-4200.

Cette publication s'appuie sur l'information qui était disponible au moment de l'impression. À la société **AutomationDirect**, nous nous efforçons constamment d'améliorer nos produits et services. C'est pourquoi nous nous réservons le droit d'apporter des modifications aux produits ou aux publications en tout temps, sans préavis ni quelque obligation que ce soit. La présente publication peut aussi porter sur des caractéristiques susceptibles de ne pas être offertes dans certaines versions révisées du produit.

Marques de commerce

La présente publication peut contenir des références à des produits fabriqués ou offerts par d'autres entreprises. Les désignations des produits et des entreprises peuvent être des marques de commerce et appartiennent exclusivement à leurs propriétaires respectifs. **AutomationDirect** nie tout intérêt dans les autres marques et désignations.

Copyright 2021-2025, **Automationdirect.com**[®] Incorporated
Tous droits réservés

Nulle partie de ce manuel ne doit être copiée, reproduite ou transmise de quelque façon que ce soit sans le consentement préalable écrit de la société **Automationdirect.com**[®] Incorporated. **AutomationDirect** conserve les droits exclusifs à l'égard de tous les renseignements contenus dans le présent document.

CLICK PLUS PLC User Manual



Please include the Manual Number and the Manual Issue, both shown below, when communicating with Technical Support regarding this publication.

Manual Number: C2-USER-M
 Issue: 1st Edition, Rev. U
 Issue Date: 10/2025

Publication History		
Issue	Date	Description of Changes
1st Edition	02/2021	Original
1st Edition, Rev. A	03/2021	Added Factory Reset to Troubleshooting, clarified meaning of XD, YD registers.
1st Edition, Rev. B	05/2021	Corrected Wireless LAN and Bluetooth transmission distances.
1st Edition, Rev. C	07/2021	Added resetting to factory defaults using Run/Stop switch in Troubleshooting.
1st Edition, Rev. D	11/2021	Added C2-0xCPU-2 CPUs, C2-DCM Option Slot module and MSD-SLC16G SD Card.
1st Edition, Rev. E	02/2022	Clarified EtherNet/IP only available on RJ45 ports.
1st Edition, Rev. F	04/2022	Added High-Speed Output functions in software v.3.30.
1st Edition, Rev. G	09/2022	Corrected WLAN security specifications.
1st Edition, Rev. H	11/2022	Updated Koyo Electronics Industries CO., LTD. to JTEKT Electronics Corporation.
1st Edition, Rev. I	12/2022	Added "Silent Install" feature. Removed Type 1 fonts.
1st Edition, Rev. J	03/2023	Clarified UL insulation requirements. Corrected MSD-SLC16G max temperature.
1st Edition, Rev. K	05/2023	Changed references to CLICK software media from CD to USB.
1st Edition, Rev. L	12/2023	Corrected firmware update time.
1st Edition, Rev. M	01/2024	Clarified CLICK PLUS CPUs maximum power consumption.
1st Edition, Rev. N	05/2024	Clarified current limitations on relay outputs when using ZIPLink wiring system.
1st Edition, Rev. O	09/2024	Added Remote PLC App.
1st Edition, Rev. P	10/2024	Dimensioned depth in C2-series CPU drawing.
1st Edition, Rev. Q	02/2025	Added C2-NRED, C2-OPCUA, C2-14TTL and C0-04POT modules.
1st Edition, Rev. R	04/2025	Added link to Node-RED module compatibility utility.
1st Edition, Rev. S	05/2025	Updated Third-party Node-RED node compatibility table.
1st Edition, Rev. T	09/2025	Security updates: password required and Bluetooth disabled by default.
1st Edition, Rev. U	10/2025	Clarified clock setting requirement for C2-OPCUA, corrected typo in C2-OPCUA troubleshooting.



TABLE OF CONTENTS

Chapter 1 - Getting Started

Introduction.....	1-2
Conventions Used.....	1-3
Before you begin.....	1-4
Step 1: Install Software.....	1-5
Step 2: Launch Programming Software	1-7
Step 3: Set Up User Account.....	1-9
Step 4: Create a Project.....	1-10
Step 5: Compile and Save Project.....	1-16
Step 6: Apply Power	1-17
Step 7: Establish PC to PLC Communications.....	1-18
Step 8: Write Project into PLC.....	1-30
Step 9: Place PLC in RUN Mode	1-31
Step 10: Test Project using Data View Monitor	1-32
Step 11: Y001 Output On?.....	1-33
Step 12: Test Project Using Remote PLC App.....	1-34
Additional Training Resources	1-38

Chapter 2 - Specifications

Overview of PLC System	2-2
Regulatory and Standards Compliance.....	2-3
CLICK PLUS PLC Units	2-4
Option Slot I/O Modules	2-6
Option Slot Intelligent Modules	2-8

Stackable I/O Modules	2-9
Power Budgeting	2-13
PLC Unit Specifications	2-16
Option Slot I/O Module Specifications	2-31
Option Slot Intelligent Module Specifications	2-86
Stackable I/O Module Specifications.....	2-93
Power Supply Specifications.....	2-130
Programming Software	2-133
Data Types, Memory, and Numbering System	2-134
PLC Operation.....	2-138
Accessories.....	2-142

Chapter 3 - Installation and Wiring

Safety Guidelines.....	3-2
Introduction to the CLICK PLUS PLC Mechanical Design.....	3-5
Mounting Guidelines	3-10
Installing the CLICK PLUS PLC	3-20
Wiring Guidelines.....	3-22
I/O Wiring Checklist	3-30
System Wiring Strategies	3-31
LAN Provisioning over Bluetooth	3-42
Option Slot Analog I/O Configuration.....	3-46
High-Speed Input/Output Configuration.....	3-53
Setting Up and Using an SD Card.....	3-58

Chapter 4 - PLC Communications

Introduction.....	4-2
PLC Communication Ports Specifications	4-3
LED Status Indicators.....	4-4
Remote PLC App Configuration and Use.....	4-6

C2-DCM Intelligent Module Communication Ports Specifications 4-7

3 Steps to Using the CLICK PLC Communications 4-8

Typical Communication Applications 4-9

W-1: USB Port Wiring 4-13

W-2: Com Port 2 (RS-232) Wiring 4-14

W-3: Com Port 1 (Ethernet) Wiring 4-18

W-4: Com Port 3 Wiring 4-20

W-5: C2-DCM Com Port RS-232 Wiring 4-21

W-6: C2-DCM Com Port RS-485 Wiring 4-22

C-1: USB Port Setup 4-23

C-2: Com Port 1 (Ethernet) Setup 4-24

C-3: Wireless LAN (WLAN) Setup 4-25

C-4: Bluetooth Setup 4-26

C-5: Com Port 2 Setup (Modbus RTU) 4-27

C-6: Com Port 2 Setup (ASCII) 4-28

C-7: Com Port 3 Setup (Modbus RTU) 4-29

C-8: Com Port 3 Setup (ASCII) 4-30

C-9: C2-DCM Com Port 1 or 2 Setup (ASCII) 4-31

C-10: C2-DCM Com Port 1 or 2 Setup (Modbus RTU) 4-32

P-1: Modbus Slave (Server) Programming 4-33

P-2: Modbus Master Programming (Modbus RTU) 4-37

P-3: Modbus Client (Modbus TCP) Programming 4-42

P-4: ASCII Receive Programming 4-48

P-5: ASCII Send Programming 4-51

Chapter 5 - Intelligent Modules

CLICK PLUS Intelligent Modules 5-2

C2-DCM Communication Module 5-2

C2-NRED Node-RED Module 5-3

C2-OPCUA OPC UA Server Module 5-28

Chapter 6 - Maintenance

PLC Maintenance 6-2

Chapter 7 - Troubleshooting

Troubleshooting Direction 7-2
PLC unit Troubleshooting 7-3
Bluetooth Troubleshooting 7-5
Wireless LAN Troubleshooting 7-6
USB Troubleshooting 7-7
SD Card Troubleshooting 7-8
Power Supply Troubleshooting..... 7-9
I/O Module Troubleshooting 7-10
Resetting to Factory Defaults 7-14
Troubleshooting Electrical Noise Problems..... 7-15
Error Codes..... 7-16

Appendix A - Security Considerations for Control Systems Networks

Security Considerations for Control Systems Networks..... A-2

GETTING STARTED



CHAPTER 1

In This Chapter...

Introduction	1-2
Conventions Used.....	1-3
Before you begin.....	1-4
Step 1: Install Software	1-5
Step 2: Launch Programming Software	1-7
Step 3: Set Up User Account.....	1-9
Step 4: Create a Project	1-10
Step 5: Compile and Save Project.....	1-16
Step 6: Apply Power	1-17
Step 7: Establish PC to PLC Communications.....	1-18
Step 8: Write Project into PLC.....	1-30
Step 9: Place PLC in RUN Mode	1-31
Step 10: Test Project using Data View Monitor	1-32
Step 11: Y001 Output On?.....	1-33
Step 12: Test Project Using Remote PLC App.....	1-34
Additional Training Resources	1-38

Introduction

Purpose of this Manual

Thank you for purchasing the AutomationDirect CLICK PLUS PLC family of products. This hardware user manual provides information that will help you install, set up, program, troubleshoot, and maintain your CLICK PLUS PLC system. The manual includes information that is critical to the safety of the personnel who will install and use the PLC, as well as the integrity of the machinery, processes, and equipment controlled by the PLC.

The manual also includes important information about power and signal wiring, mounting of the PLC, and configuring the PLC system.

About Getting Started

If you are familiar with PLCs in general, then following the simple steps in this first chapter may be all you require to start being productive using a CLICK PLUS PLC system. After you have completed these simple steps, your CLICK PLUS PLC will be running a ladder logic project that you programmed. If you are new to the world of PLCs, be sure to read through all of the chapters in this hardware user manual.

Supplemental Manuals and Other Help

The CLICK Programming Software, C0-PGMSW, can be downloaded free from the AutomationDirect web site (link shown below under Technical Support). Both this Hardware User Manual, *C2-USER-M*, and the *Software Installation Guide* are free as a download. **The CLICK Programming Software includes searchable online help topics covering all aspects of the software and instruction set.**

Technical Support

We strive to make our manuals the best in the industry. We rely on your feedback to let us know if we are reaching our goal. If you cannot find the solution to your particular application, or, if for any reason you need technical assistance, please call us at:

770-844-4200

Our technical support group will work with you to answer your questions. They are available Monday through Friday from 9:00 A.M. to 6:00 P.M. Eastern Time. We also encourage you to visit our web site where you can find technical and non-technical information about our products and our company.

<http://www.automationdirect.com>

Conventions Used



WARNING: When you see the exclamation point icon in the left-hand margin, the paragraph to its immediate right will be a warning. This information could prevent injury, loss of property, or even death in extreme cases. Any warning in this manual should be regarded as critical information that should be read in its entirety. The word **WARNING:** in boldface will mark the beginning of the text.



NOTE: When you see the notepad icon in the left-hand margin, the paragraph to its immediate right will be a special note. Notes represent information that may make your work quicker or more efficient. The word **NOTE:** in boldface will mark the beginning of the text.



TIP: Whenever the "light bulb" is shown in the left-hand margin, the paragraph to its immediate right will provide a special tip. The word **TIP:** in boldface will mark the beginning of the text.

Key Topics for Each Chapter

The beginning of each chapter will list the key topics that can be found in that chapter.

Getting Started!		CHAPTER 1
In This Chapter...		
Introduction		1-2
Purpose of this Manual		1-2
About Getting Started!		1-2
Supplemental Manuals and Other Help		1-2
Technical Support		1-2
Conventions Used		1-3

Before you begin...

It is recommended that the following items be available to make this short step-by-step introduction to the CLICK PLUS PLC go smoothly.

CLICK PLUS PLC unit



**CLICK 24VDC Power Supply
C0-00AC or C0-01AC**



**Other 24VDC Power Supply
Example: PSP24-60S**



or

**PC Running
Windows**



Not available from ADC.

**CLICK
Programming Software
C0-PGMSW**



USB or Free download @
[http://support.automationdirect.com/
products/clickplcs.html](http://support.automationdirect.com/products/clickplcs.html)

**Based on your CLICK PLUS PLC,
One of the cables shown below:**



Ethernet Cat5 Cable

**USB A to USB micro B
Programming
Cable Assembly
USB-CBL-AMICB6**



**Screwdriver
TW-SD-MSL-2**



**Wire Strippers
DN-WS**



Hookup Wire



AC Power Cord



Not available from ADC.

**PC Programming Cable
D2-DSCBL**



PC requires RS-232 port.

Step 1: Install Software

The CLICK PLC family offers two methods of connecting and configuring the PLCs

1. CLICK PLC mobile app for iOS and Android devices
2. CLICK programming software for Windows-based PCs

Installing the CLICK PLUS Provisioning Mobile App

The CLICK PLUS Provisioning App connects your mobile device to a CLICK PLUS PLC via Bluetooth and offers a quick plug and play way to provision the CLICK PLUS PLC to connect to a wireless LAN.

Install the CLICK PLUS Provisioning mobile app from the Apple App Store or Google Play Store (CLICK PLUS Provisioning, published by Automationdirect.com).



Install the CLICK Programming Software

1. If you have the programming software on USB, insert the USB drive in a USB slot and follow the instructions. Otherwise, download the free CLICK Programming Software, C0-PGMSW, from the following Automationdirect.com web site:
<http://support.automationdirect.com/products/clickplcs.html>
2. Unzip the downloaded ZIP file.
3. Double click Install.exe. The CLICK PLC Programming Software splash screen should appear after a short time.
4. Click on the splash screen's Install Software button and follow the dialog boxes.

Silent Install

The silent install feature allows the software to be installed from the Windows command line or deployment management software without further user interaction.

Command for Silent Install: **CLICK_Setup.exe -s**

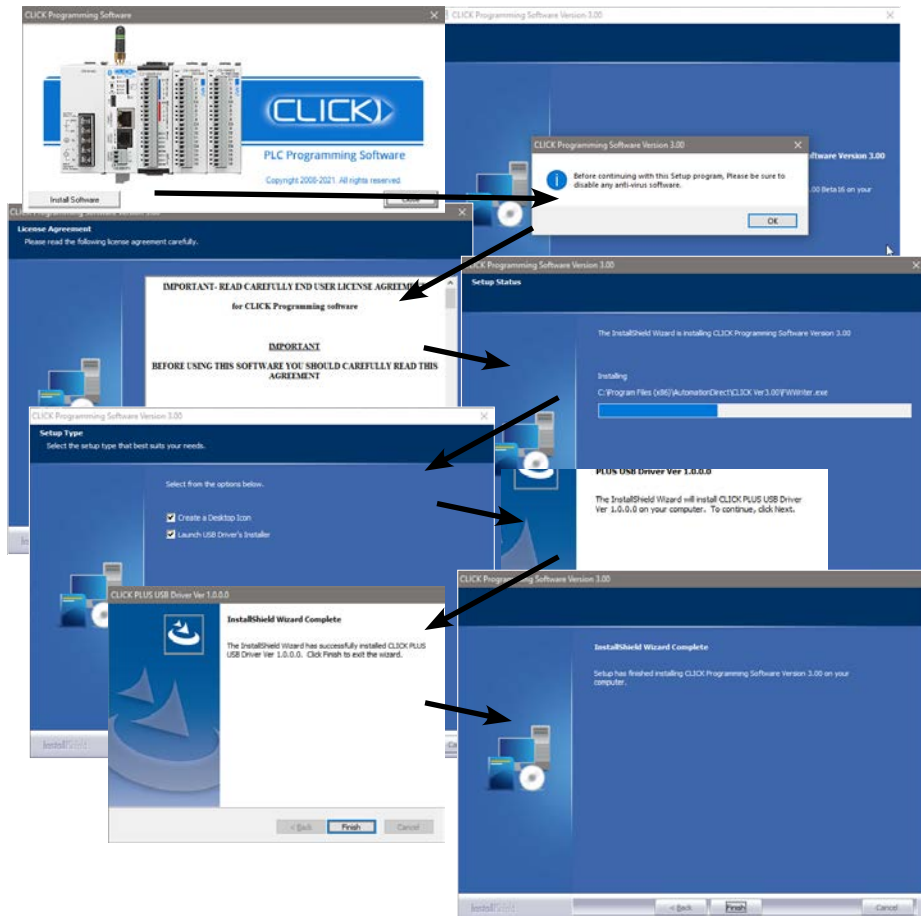

Step 2: Launch Programming Software

After installing the CLICK Programming Software, C0-PGMSW, choose one of three methods to launch the software. Double click the desktop CLICK icon, or from the PC's Start menu, select Start > AutomationDirect > CLICK Programming Software, or simply click the icon on the Quick Launch bar. See examples below.

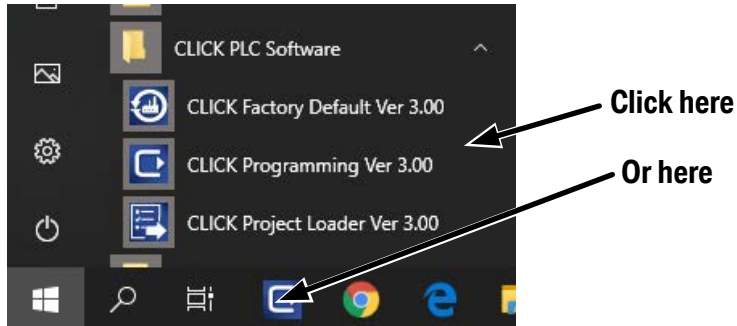

The CLICK Programming Software will start up and display the Main Window as shown on the next page.

The example in this manual use the 'Classic' user interface of the CLICK programming software. If you are starting the software for the first time, you may want to change to this UI to follow the example more easily. To do so, click the Theme button in the upper right of the display, and select Change UI (Classic/Ribbon).

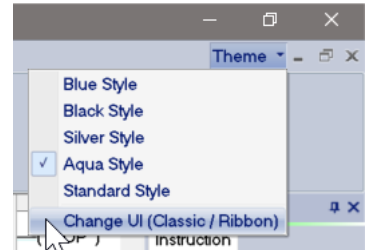

NOTE: The recommended minimum screen size for the CLICK Programming Software is 1024 X 786 pixels.

Step 2: Launch Programming Software (cont'd)

The Main Window is divided into Menus, Toolbars, and Windows that work together to make project development as simple as possible. See the software's online help for additional details.

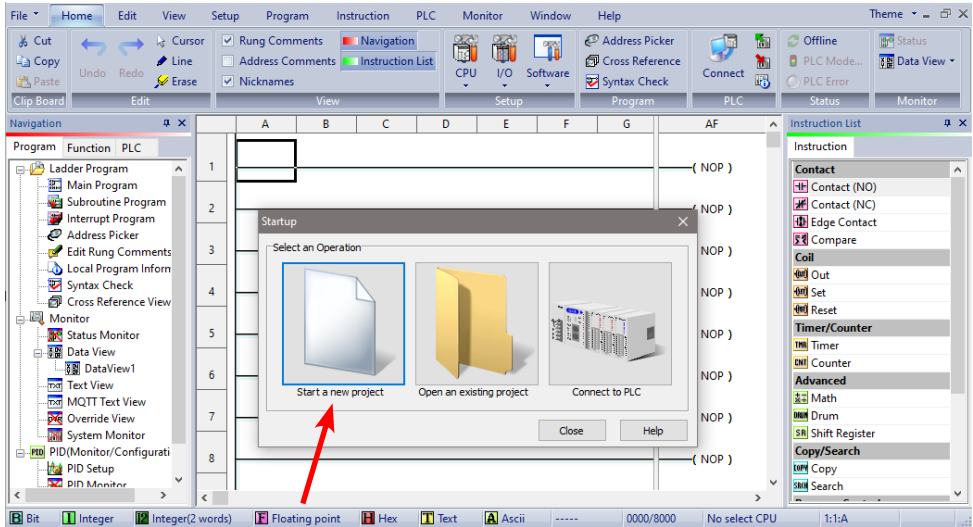

Click on the “Start a new project” graphic in the Startup dialog box. The Select a CPU Module window opens.

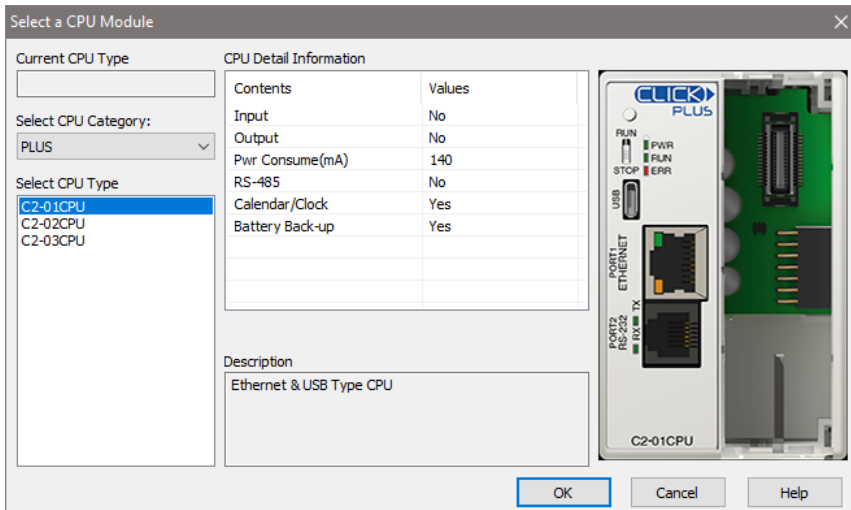

Select from the list on the left for the CLICK PLUS PLC unit that you will use for the ladder logic example that follows.

Step 3: Set Up User Account

A single 'admin' user account exists on the CLICK platform, with the default password set to 'click'. This must be disabled or changed to a unique password in any project for a CLICK CPU with network capabilities before it can be downloaded. This helps greatly reduce the chances of malicious software taking control of the PLC with easy-to-guess or publicly disclosed default login credentials.

The User Account Setup dialog guides you through setting up a strong password and monitoring password activity. This dialog opens when creating a new project, if a CPU with network capabilities is selected, and can also be accessed at any time from the User Account Setup menu option.

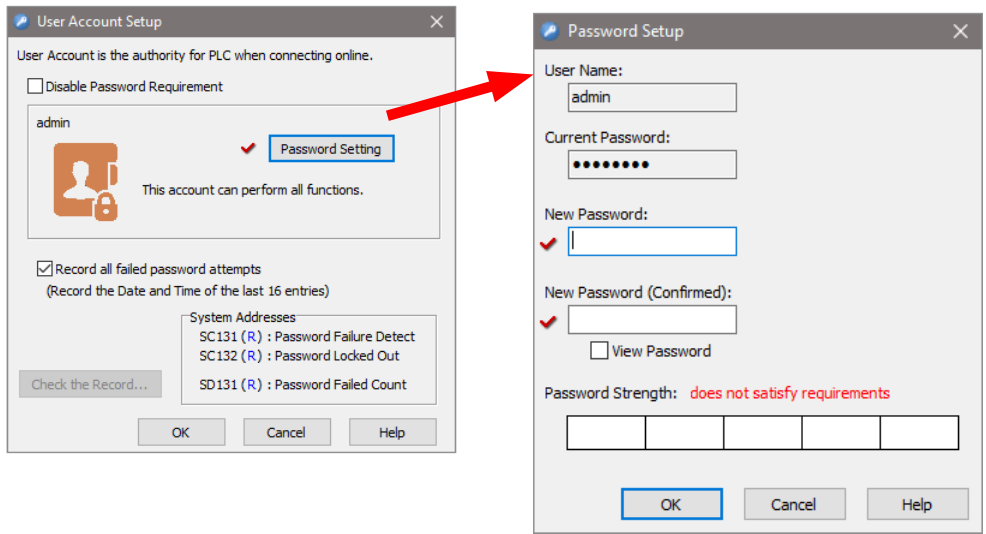

The password must be at least 8 characters long, and the following special characters are not allowed:

, “ < > ‘ () + - . / : ; = ? [\] ^ ` { | } ~



NOTE: Make sure you remember your Password. If you forget your Password you will not be able to access the CPU. You can use the Reset to Factory Default command to erase the Password. However, the command erases the Entire Project file. Therefore, you will have to download a project file again.



NOTE: The C2-02CPU, C2-02CPU-2, C2-03CPU, and C2-03CPU-2 PLCs REQUIRE a password to be setup before a project can be transferred. The Disable Password Requirement button is unavailable for these PLCs.

Step 4: Create a Project

In this step, we'll create a simple project. The project assumes the presence of an I/O module with discrete outputs. The project shown below is created by entering the ladder logic program in the order that follows.

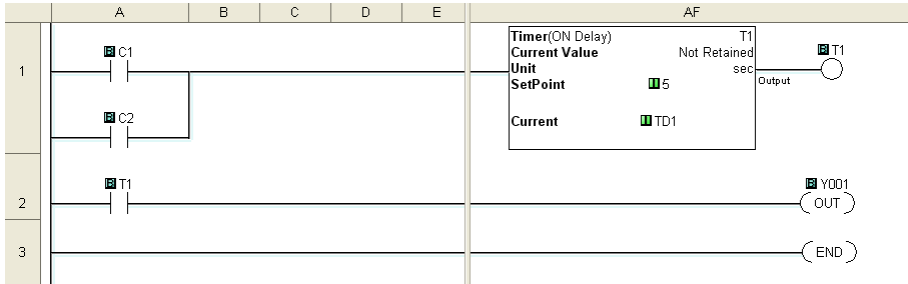

Rung #1

Place the Box Cursor on the first position on Rung #1, as shown below. From the Instruction List, click & drag a Contact (NO) into this box. Enter C1 into the Bit Memory Address text box of the Contact Normally Open dialog box that pops up and click OK.

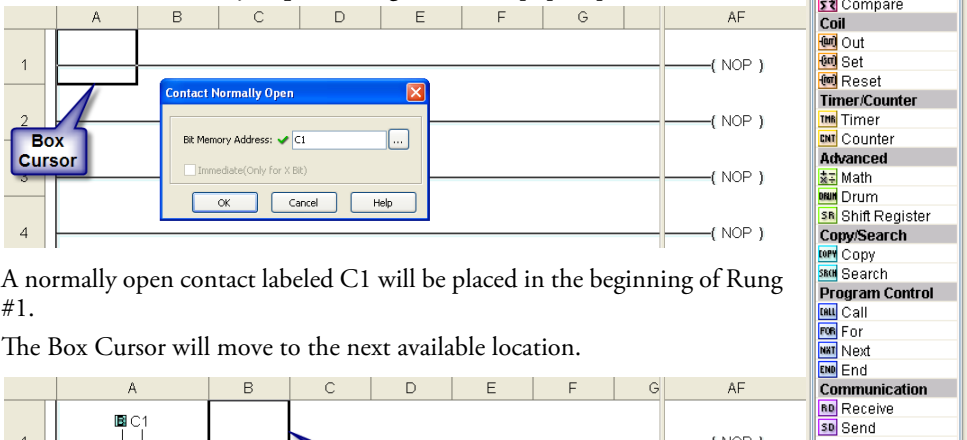

A normally open contact labeled C1 will be placed in the beginning of Rung #1.

The Box Cursor will move to the next available location.

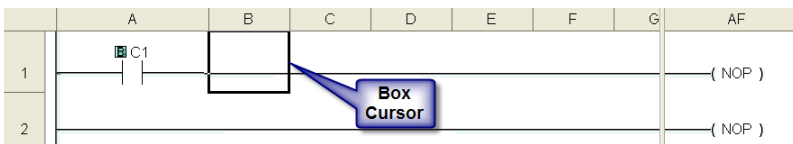

Proceed to the next page to continue construction of Rung #1.

Step 4: Create a Project (cont'd)

Rung #1 (cont'd)

The Line creation tool is used to add a normally open contact in parallel with the C1 contact. Click on the Line creation tool icon located on the Edit toolbar. A blue line will appear, showing the direction of the new line. The Line pen is used to redirect the new line.

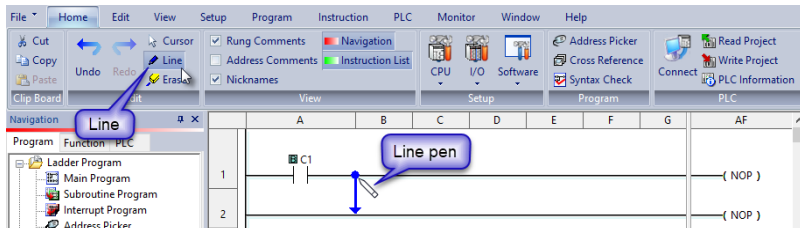

Move the mouse pointer to the end of the new line (arrow) until the mouse pointer becomes a hand with a pointing index finger. Click on the line's arrow.

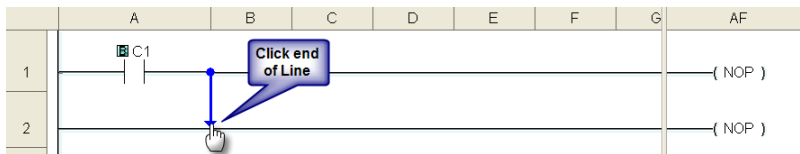

Additional new lines are shown in blue. Move the mouse pointer to the end of the new line that extends to the left and click.

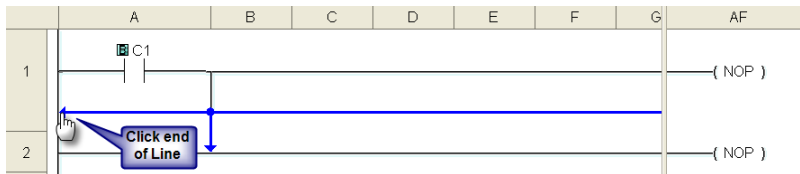

There is now a parallel path around the C1 contact that was first entered as shown here.

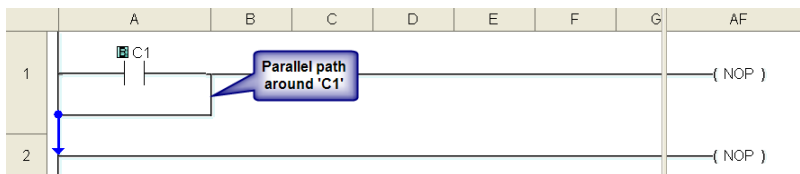

Proceed to the next page to continue construction of Rung #1.

Step 4: Create a Project (cont'd)

Rung #1 (cont'd)

Next, click on the **Cursor Mode** icon located on the Edit toolbar (Esc key has the same function as the **Cursor Mode**). The Box Cursor will move to the newly created path. If not, position the Box Cursor over the new path to get ready for the next instruction.

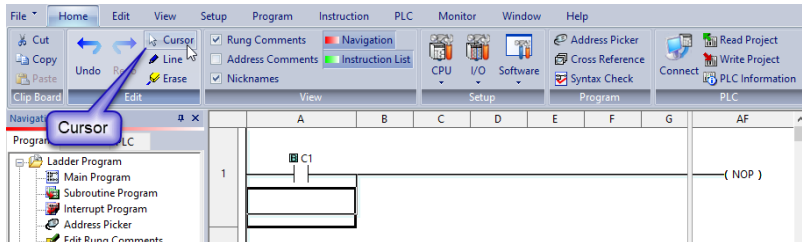

NOTE: There is also a **Line Erase** tool icon next to the **Line** tool icon on the **Edit** toolbar that is used to erase any of the lines that were created using the **Line** tool. Also, to exit the **Line** or **Line Erase** function, click on the **Cursor Mode** icon on the **Edit** toolbar. All of the **Line** type tools are also available under the **Edit** drop down menu.



NOTE: Lines to form parallel paths in the ladder logic can also be created with the use of the cursor keys in conjunction with the **CTRL** key on the PC's keyboard.

Proceed to the next page to continue construction of Rung #1.

Step 4: Create a Project (cont'd)

Rung #1 (cont'd)

From the Instruction List, click & drag a Contact (NO) into the Box Cursor. Enter C2 into the Bit Memory Address text box of the Contact Normally Open dialog box that pops up and click OK. A normally open contact labeled C2 will be placed in parallel with the C1 contact.

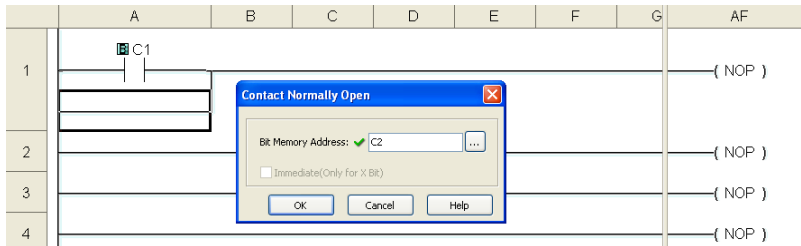

Next, place the Box Cursor on the NOP coil at the far right of Rung #1. NOP stands for No Operation and is a place holder in the ladder logic Coil Area. Click and drag a Timer from the Instruction List into this location. Within the Timer dialog box, enter T1 into the Timer Number text box, the value 5 into the Set Point, and select sec for the timing Unit. The Timer dialog box shows a Timing Chart that graphically represents the function of the ON Delay Timer, and also shows a selection for an alternative OFF Delay Timer mode of operation.

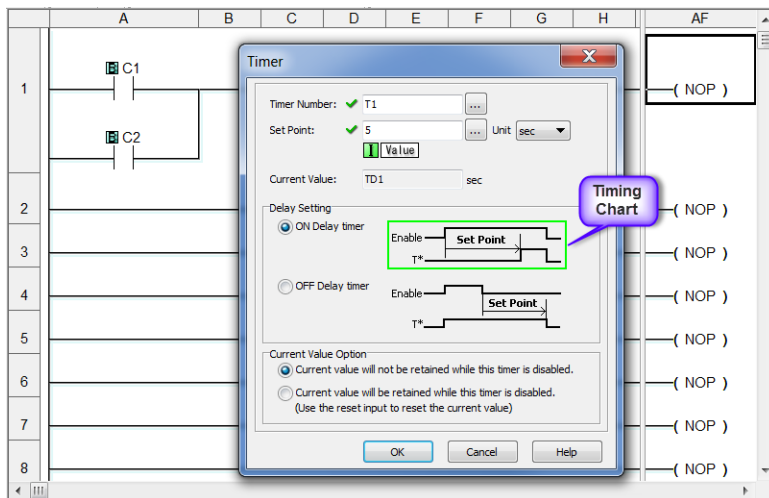

Leave the Delay Setting at ON Delay Timer and the Current Value Option set for the first selection. Click OK. A timer labeled T1 will be placed at the end of Rung #1.

Proceed to the next page to enter Rung #2.

Step 4: Create a Project (cont'd)

Rung #2

Place the Box Cursor at the beginning of Rung #2. From the Instruction List, click and drag a Contact (NO) into this box. Enter T1 into the Bit Memory Address text box of the Contact Normally Open dialog box that pops up. Click OK. A normally open contact labeled T1 will be placed in the beginning of Rung #2.

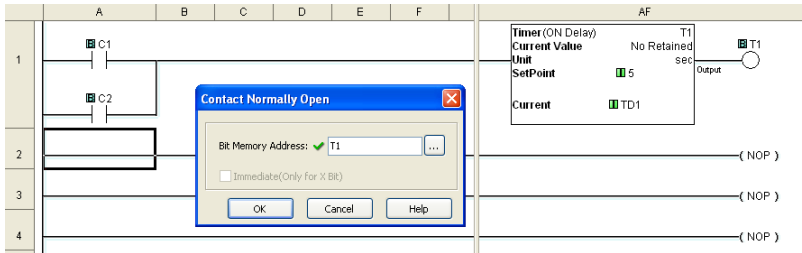

Next, place the Box Cursor on the NOP coil at the far right of Rung #2. Click and drag an OUT from the Instruction List into this location. Within the Out dialog box, enter Y001 into the Bit Memory Address: text box. Click OK. An out coil labeled Y001 will be placed at the end of Rung #2.

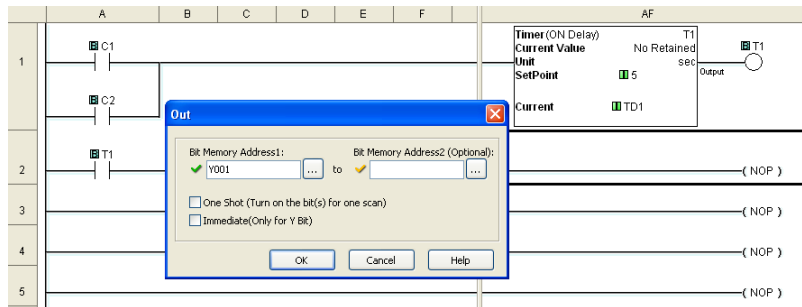

Rung #3

Finally, place the Box Cursor on the NOP coil at the far right of Rung #3. Click and drag an END from the Instruction List into this location. An END instruction indicates the last part of the main ladder logic program. You have created your first project!

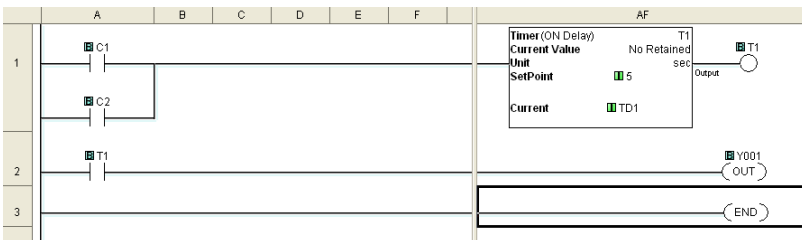

Step 4: Create a Project (cont'd)

Program Execution

The following is an explanation of how the CLICK PLC executes the ladder logic program that was just entered.

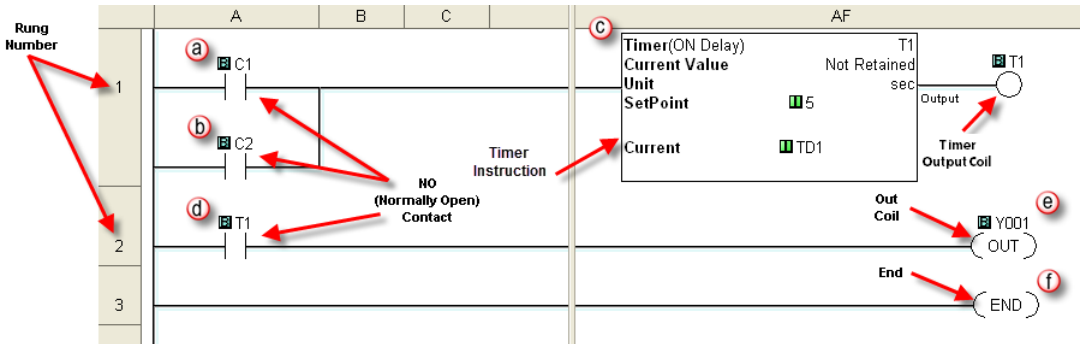

The CLICK PLC executes the ladder logic program instructions, starting with Rung #1, from left to right, and then proceeds to execute the next rung in the same fashion, carrying on through all of the rungs in sequential order. The 6 instructions (a, b, c, d, e, and f) in the above ladder logic program are executed in the following order.



Explanation of the Program Execution

- (a) (b)** NO (Normally Open) Contact: Address C1 and C2 are assigned to a NO Contact. C1 and C2 are internal control bits. The internal control bits are 1 bit memory and hold the status of ON or OFF. The contacts are enabled when the status of C1 or C2 is ON.
- (c)** Timer: This instruction is used to delay an action once it is enabled. The CLICK PLC unit can use up to 500 timers (T1 to T500) in a project. In this ladder logic program, timer T1 is assigned. The Timer instruction is set up as an ON Delay Timer with a 5 second set point. That is, the timer status bit T1 output coil turns on 5 seconds after the enable input of the Timer instruction turns on.
- (d)** This is a NO Contact addressed as T1 and whose status is controlled by Timer T1. The contact is enabled when Timer T1 output coil becomes true after the 5 second delay.
- (e)** OUT: This is an output coil addressed as real world output Y001, which happens to be the first output on the CLICK PLC unit. It becomes active when the T1 NO Contact in this rung becomes enabled.
- (f)** END: This is the END of the ladder logic scan, and causes the scan to start at the beginning.

Step 5: Compile and Save Project

Syntax Check (Compile)

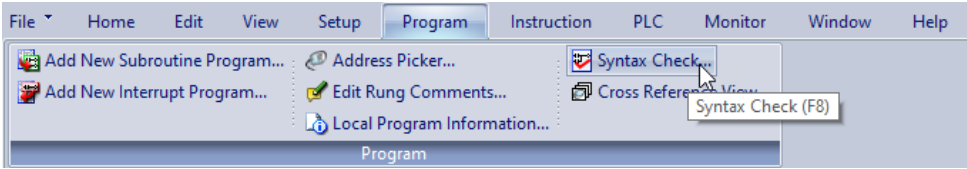

Next, you will need to compile the ladder logic program. Compiling the program is done with the Syntax Check function. The ladder program is checked for problems and other conditions that may prevent the ladder program from executing correctly. The results of the Syntax Check are displayed in the Output Window at the bottom of the Main Window as shown below.

From the Program drop down menu, select Syntax Check as shown at left, or press the F8 function key on your keyboard, or click on the Syntax Check icon located on the Program Toolbar.

If everything in the program checks out correctly, then the Output Window will indicate 0 error(s) as shown in the following example.



If there are any errors, they will be indicated in the Output Window. For quicker troubleshooting, double click on any particular error in the Output Window and be taken directly to the rung and instruction that may be causing the error. The following is an example of an error.

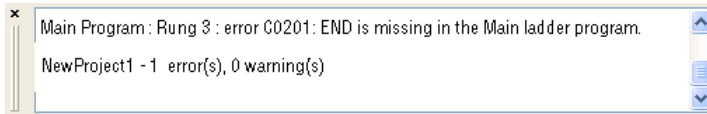

Save Project

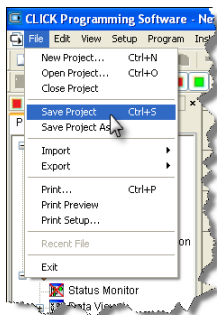

It is always a good practice to save your project at this point. From the File drop down menu, select Save Project, as shown here, or click on the Save Project icon located on the File Toolbar.

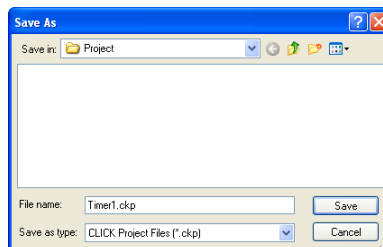

Enter the File Name for your project in the Save As dialog box. You can also browse to the folder that you want the project saved under. Click Save.

Step 6: Apply Power

The CLICK PLUS PLC system works with 24VDC power. There is a small terminal block on the bottom of the CLICK PLUS PLC unit. Wire the 24VDC output from a CLICK power supply, or a properly sized and rated 24VDC power supply such as AutomationDirect's RHINO series, to the bottom terminal block (See Chapter 2: Specifications for power supply specifications.)

EITHER

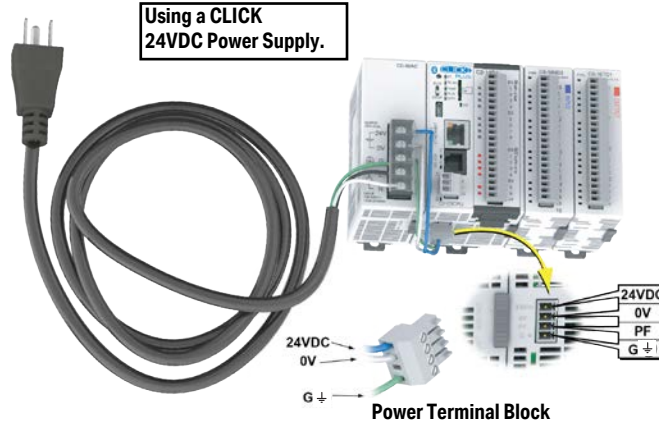

OR

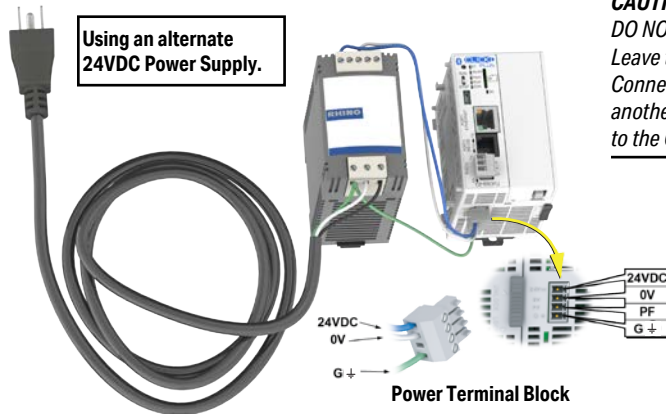

CAUTION:

DO NOT USE the PF connector. Leave this terminal unconnected. Connecting the PF terminal to another device may cause damage to the CLICK PLUS CPU.

Once you wire and power up the power supply, confirm the PWR indicator (Green LED) on the CLICK PLUS PLC unit is on.

If the PWR indicator is not on, check the voltage on the terminal block with a voltage meter. If you measure 24VDC on the terminal block, the CLICK PLUS PLC unit may be defective. Please try another one or contact us for a replacement.



Step 7: Establish PC to PLC Communications

Next, connect a personal computer (PC) to the CLICK PLUS PLC unit. You can use any of the following communication ports on the CLICK PLUS PLC unit for programming, depending on model.

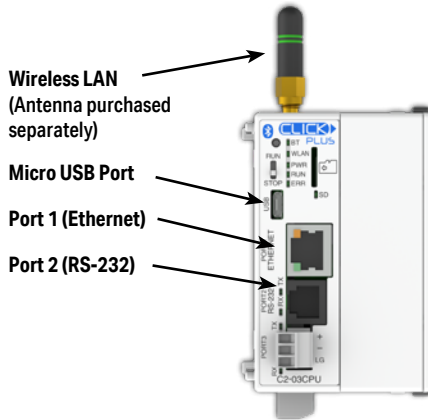

NOTE: Connection via wireless LAN requires provisioning the CLICK PLUS PLC onto your wireless LAN. This initial setup can be performed through the CLICK Provisioning mobile app over Bluetooth, as described on page 1-21. It can also be done through the USB connection or wired LAN connection with the CLICK programming software.

Step 7: Establish PC to PLC Communications (cont'd)

Using a USB or Serial Port for Programming

Connecting to a USB Port

If a USB port is available on the PC, then use an AutomationDirect USB A to USB micro B Programming Cable (P/N - USB-CBL-AMICB6) to connect between the USB port on the PC and the micro-B USB connector on the CLICK PLUS PLC., or use an AutomationDirect PC to Panel Programming Cable Assembly (P/N - EA-MG-PGM-CBL) to connect between the USB port on the PC and the RJ12 serial port on a CLICK PLC.

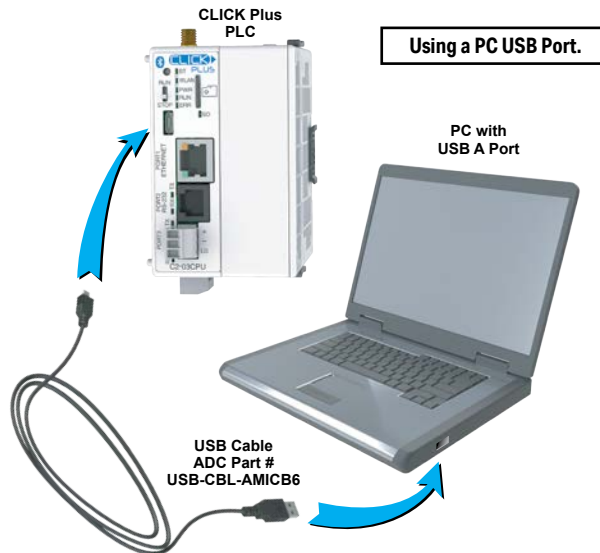

Connecting to an RS-232 Port

If a 9-pin RS-232 serial communications port is available on the PC, then use an AutomationDirect PC Serial Programming Cable (P/N - D2-DSCBL) to connect between the 9-pin port on the PC and the RJ12 connector on the PLC's RS-232 Port.

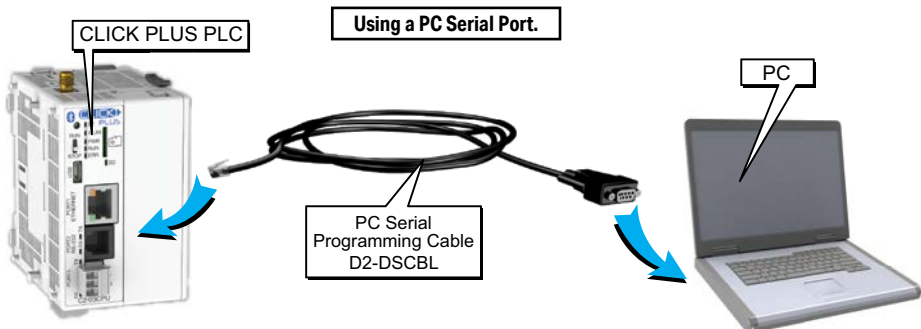

Step 7: Establish PC to PLC communications (cont'd)

Configuring the USB or RS-232 Serial Connection

Once we have a communications cable connected between a port on the PC and either the USB port or PORT2 on the CLICK PLUS PLC,

we need to select the PC COM port that is connected to the PLC. From the PLC ribbon, select Connect as shown to the right, or click on the Connect icon (left) located on the PLC Toolbar. The Connect to PLC dialog box will be displayed. Under the COM Port No.: drop down list, select the communications port that is connected to the PLC.

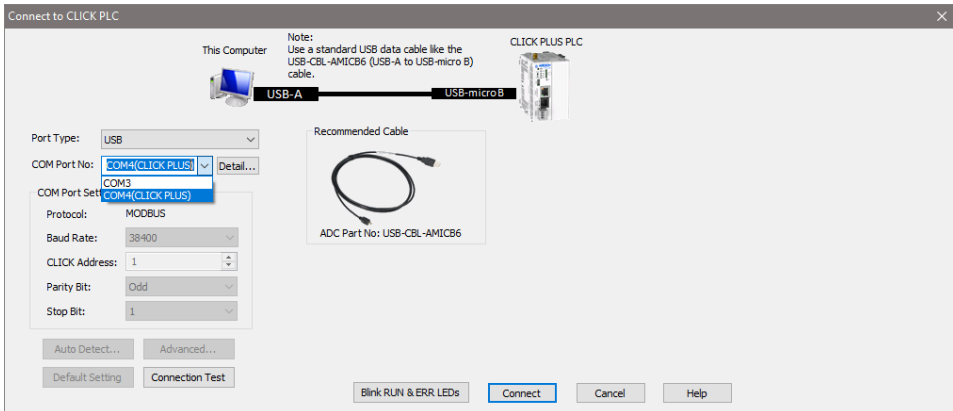
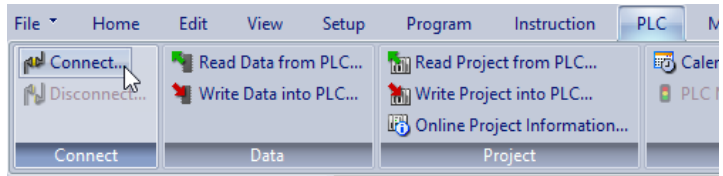

You do not need to change any of the parameters, just click the Connect button. The software should start to immediately connect to the PLC.

If you cannot connect the software to the CLICK PLUS PLC, try the above procedure one more time and keep watching the TX and RX indicators on the unit if using the RS-232 port.

If the RX is not blinking, it means the CLICK PLC unit is not receiving any data from the programming software. Check to make sure you have selected the correct PC COM Port, and also check the cable connections.

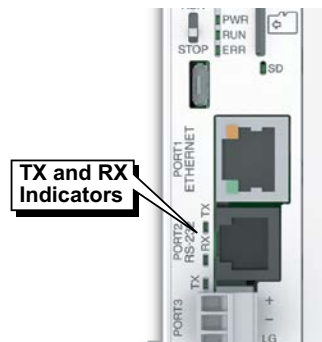

NOTE: If you are not sure to which PC COM Port the USB port is assigned, click the Detail button next to the COM Port drop down list to identify it. Select it and click OK.

Proceed to page 1-29.

Step 7: Establish PC to PLC Communications, (cont'd)

Provisioning your Wireless CLICK PLUS PLC via Bluetooth (C2-02CPU Series and C2-03CPU Series only)

A new CLICK PLUS C2-02CPU, C2-02CPU-2, C2-03CPU or C2-03CPU-2 has Bluetooth disabled by default. You must first enable the Bluetooth port in the project to use the CLICK PLUS Provisioning App. If you are setting up a Wi-Fi connection, you must also enable Wi-Fi in the project. This allows you to change the needed Wi-Fi and network settings. Once the Wi-Fi is configured to connect to the local network access point, you can then connect the Click Programming software via Wi-Fi to load and edit the project. The temporary settings used for provisioning are stored in temporary memory and will be overwritten by the project settings when you write a project to the PLC.

Install an external antenna

In order to connect to the CLICK PLUS PLC over Bluetooth or WLAN, you will need to install an external 2.4 GHz antenna. We recommend the remote-mounted AutomationDirect P/N SE-ANT250 for a permanent installation. The direct-mounted AutomationDirect P/N SE-ANT210 will also work, but is not intended for use inside a closed metal enclosure.

Prepare a Mobile Device for Connection

If you haven't already done so, install the CLICK PLUS Provisioning mobile app from the Apple App Store or Google Play Store (CLICK PLUS Provisioning, published by Automationdirect.com).



Step 7: Establish PC to PLC Communications, (cont'd)

Provisioning your Wireless CLICK PLUS PLC via Bluetooth, (cont'd)

Find the New CPU

Connect to the CPU, as follows:

1. Connect to the CPU through USB or Ethernet, set up the project password and enable the Bluetooth and/or WLAN Port(s). Send to CPU.
2. Open the CLICK PLUS Provisioning App.
3. Tap *Start* in the App.
4. Press the pairing button on the CLICK PLUS CPU for 1 second. The BT (Bluetooth) LED will start flashing.
5. The App will find the CLICK PLUS PLC that is in Provisioning mode. The blue BT LED will be ON solid when the App is connected to the PLC.

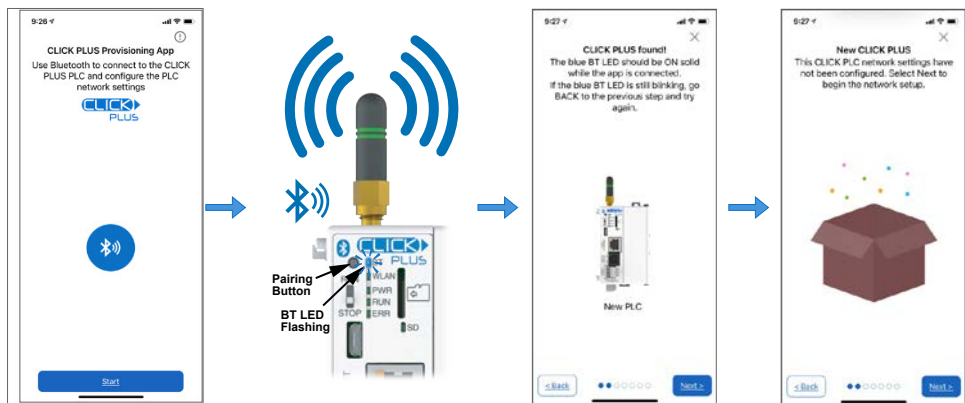

NOTE: If you find that you need to change the settings in order to connect to the network. The PLC can be placed in pairing mode and the provisions app can be used to make needed changes.

Step 7: Establish PC to PLC Communications, (cont'd)**Provisioning your Wireless CLICK PLUS PLC via Bluetooth, (cont'd)***Name the CPU and select port to configure*

6. You will be requested to assign a name to the PLC. This name will be used to identify it on the network when using the programming software connection Ethernet browse tool. It is good practice to choose a unique name if there are other CLICK PLCs on the network. Enter a name for the PLC and tap *Next*.
7. Choose which network port to provision. This will configure the CLICK PLUS network address settings for the purpose of connecting the programming software.

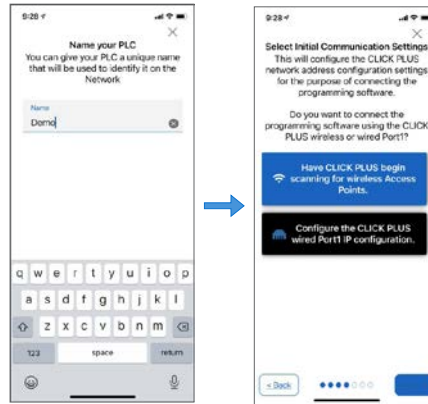
*Setup the Wireless LAN Connection (Skip for Wired Connection)*

For this option you will need an active Network Access point available within range of the CLICK PLUS PLC, and know the password to allow the PLC to connect to the Network.

8. The CLICK PLC will scan for any access point within range and then display all access points that are available (you may need to scroll the list to find the desired Access Point). Select an Access Point and type in the correct password that the PLC will need to connect. If the incorrect password is entered, you will be prompted to correct it after the CLICK PLUS fails to connect.

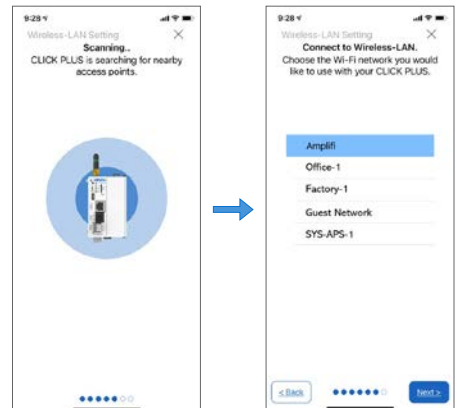

Step 7: Establish PC to PLC Communications, (cont'd)

Provisioning your Wireless CLICK PLUS PLC via Bluetooth, (cont'd)

Setup the Network Parameters

9. Once the PLC is connected to the wireless access point or wired network, choose which IP address configuration to use.
 - i. Use DHCP: Automatically assign a network IP address to the CLICK PLUS PLC. This is often the simplest way to connect. Tap *Next* to continue.
 - ii. Use Default Fixed Address: The CLICK PLUS wireless LAN default IP address is 192.168.0.11. This can be selected if it is a valid IP address for your wireless network. Tap *Next* to continue.
 - iii. Use the following IP address: Choose this option if you need to input a valid IP address for your network. Tap *Next* to continue

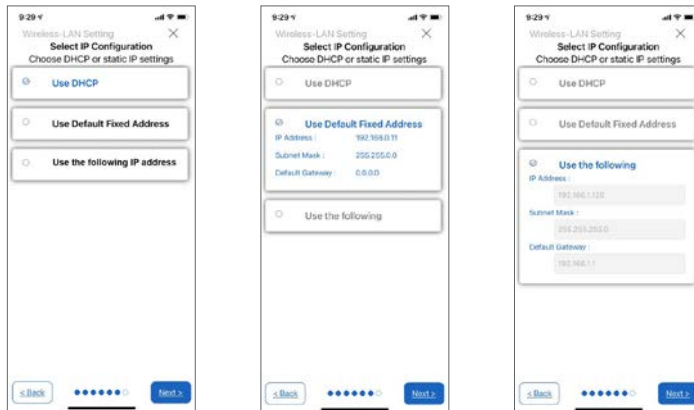

10. The CLICK PLUS will connect to the access point and exchange configuration information. If the settings are correct, the App will show the Completion screen and the network settings of the CLICK PLUS can be viewed. If using a wireless connection, the CLICK PLUS WLAN LED will also be ON. The PLC is now connected to the network and accessible to PC's running the CLICK Programming Software and connected to the same network.

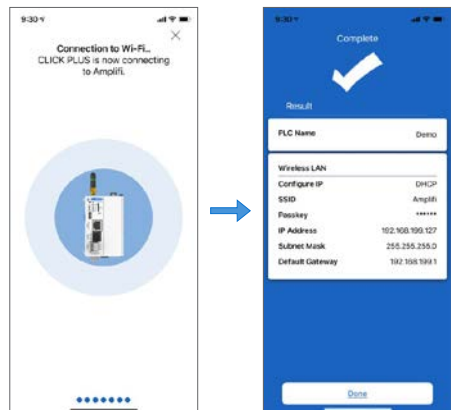

Step 7: Establish PC to PLC Communications, (cont'd)

Connecting to a Wired LAN (Models C2-01CPU and C2-03CPU only)

You can connect your PC to the CLICK PLC via an Ethernet switch/hub or directly to the Ethernet port. You can use a straight or crossover Ethernet cable.

Once we have communications cable(s) connected between the Ethernet port on the CLICK PLUS PLC and the Ethernet port on the PC, we are ready to configure the Ethernet connection and connect the CLICK Programming Software to the PLC.

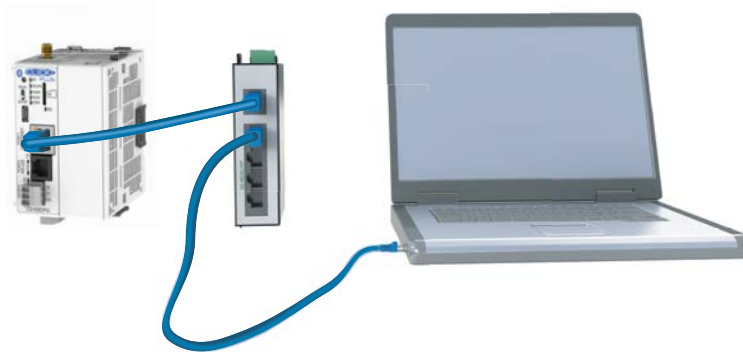

Step 7: Establish PC to PLC Communications, (cont'd)

Using a Wired or Wireless Network Connection for Programming

Configure the Ethernet Connection



From the PLC ribbon, select Connect as shown to the right, or click on the **Connect** icon located on the PLC Toolbar.

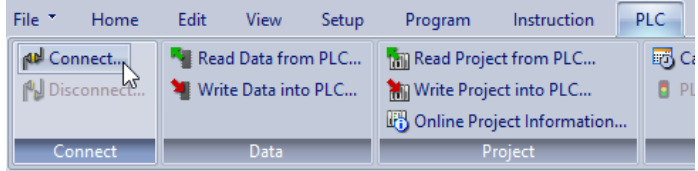

Select Ethernet as the Port Type. Select the network adapter that you want to connect to the CLICK PLUS PLC, if you have more than one network adapter on your PC. The selection of wired or wireless network adapter here is independent of the type of network connection you set up on the PLC. Choose the adapter that is on the same subnet as the PLC. The CLICK programming software automatically scans the CLICK and CLICK PLUS PLC units in the LAN connected to the network adapter and displays them in the list as shown below, or you can click the **Refresh** button to update the list.

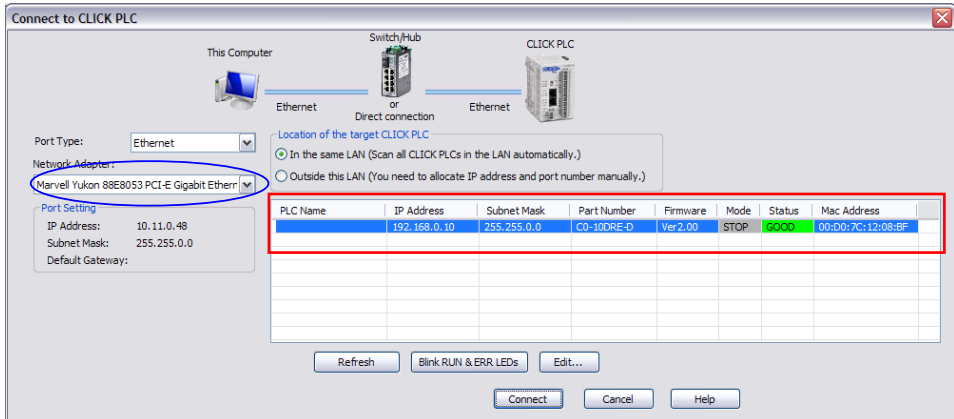

The PLC Port 1 Ethernet Port is configured by default for DHCP. If there is a DHCP server on the network then the CLICK PLC will get an IP Address compatible with the network. If there is no DHCP server on the network then the CLICK PLC will be assigned an APIPA IP Address. This will be in the form of 169.254.xxx.xxx.

To connect the CLICK programming software to the CLICK PLUS PLC, both the PC and the PLC must be in the same subnet. In the above **Connect to CLICK PLC** window, the IP Address of the PC is '10.11.0.48' and the Subnet Mask is '255.255.0.0'. You can determine the subnet that your PC is located in by applying the logical AND operation between the IP Address and the Subnet Mask.

Example: (IP Address = 10.11.0.48) AND (Subnet Mask = 255.255.0.0) = (Subnet = 10.11.0.0)

Step 7: Establish PC to PLC Communications, (cont'd)

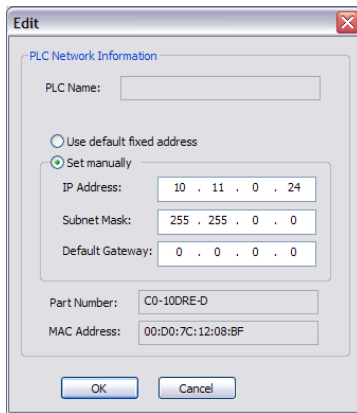

To match the subnet setup of the CLICK PLUS PLC to the subnet that your PC locates in, select the PLC unit in the list and click the **Edit** button under the list. The Edit window opens.

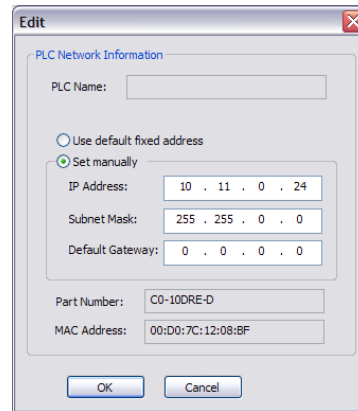

Next, the new IP Address needs to start with '10.11' to match the subnet of the PC. The following 2 numbers however, can be any number between 1 and 254 as long as the new IP Address is unique in the LAN. In the window here, the IP Address was changed to '10.11.0.24'. Click the OK button to continue. The new IP Address setup is sent to the CLICK PLUS PLC. Your PC and the CLICK PLUS PLC should be in the same subnet now. Click the Connect button on the bottom to connect the CLICK programming software to the PLC.

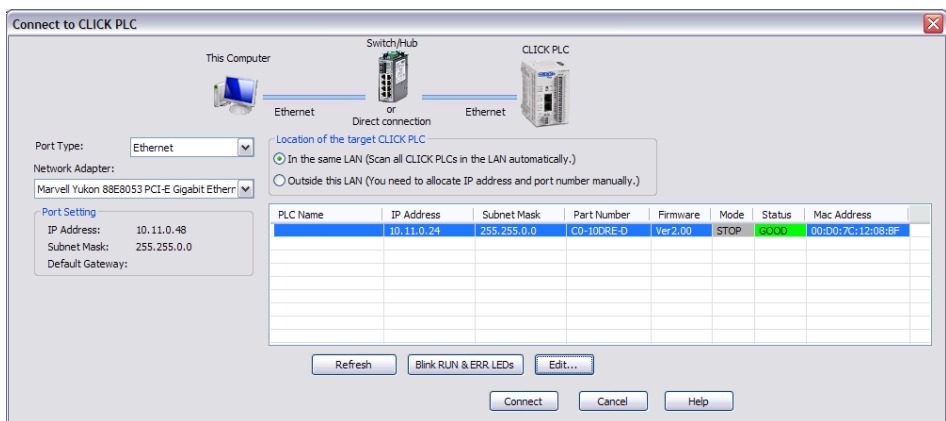

Step 7: Establish PC to PLC Communications, (cont'd)

If you are trying to connect the CLICK Programming Software to a new CLICK PLUS PLC or an existing CLICK PLUS PLC that was reset to the factory default, you will be prompted to enter the default password, as follows:

- User: admin
- Password: click

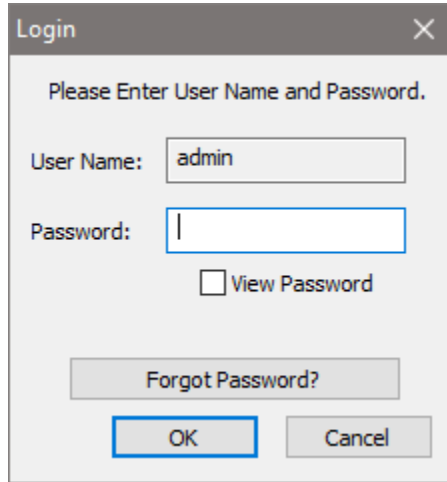

The screenshot shows a 'Login' dialog box with the following elements:

- Title bar: Login (with a close button)
- Text: Please Enter User Name and Password.
- User Name: admin
- Password: (empty field)
- View Password:
- Forgot Password? (button)
- OK (button)
- Cancel (button)

When you download your first project, the admin account password must be set to something other than the default before the project can be downloaded.

Step 7: Establish PC to PLC Communications, (cont'd)

If you are trying to connect the CLICK Programming Software to a new CLICK PLUS PLC or an existing CLICK PLUS PLC that was reset to the factory default, you will see the following pop-up message once communication has been established with the PLC. This is because there is no user project in the PLC currently. Click the OK button to close the message and proceed to the next step.

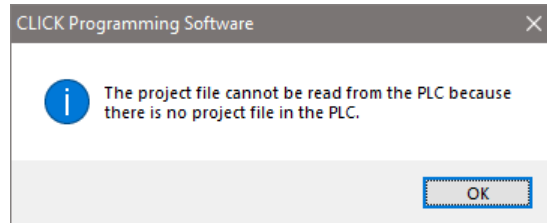

If you are trying to connect the CLICK Programming Software to a CLICK PLUS PLC that already has a user project, the following Connect dialog box will appear.

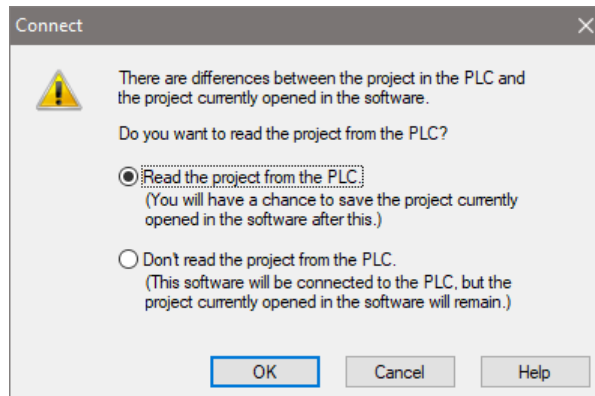

It is not unusual that the project opened in the programming software will not match the project that resides in the PLC. The dialog box gives you a choice to either read the PLC's project for viewing purposes, but at the same time allowing the project opened in the software to still be saved, or not read the project in the PLC.

For the Getting Started exercise, click the radio button for the “**Don't read the project from the PLC**” and click OK. Proceed to the next step which will allow the created project to be written into the CPU memory.

Step 8: Write Project into PLC



The next step is used to transfer the project that was created into the CLICK PLUS PLC. From the PLC ribbon, select Write Project into PLC as shown below, or click on the Write Project into PLC icon located on the PLC Toolbar.

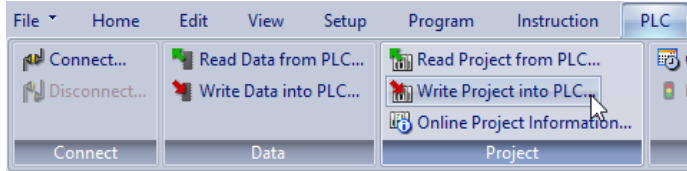

The following dialog box is displayed.

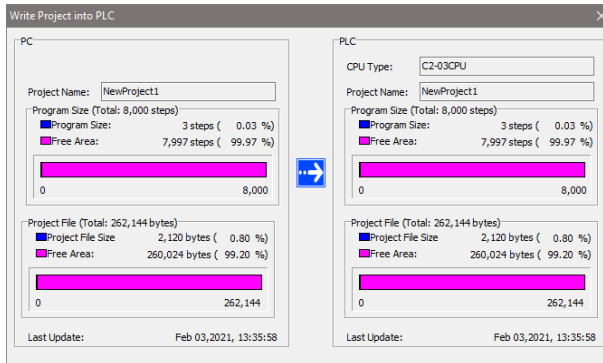

The dialog box displays the information for the Project that is currently opened in the programming software (PC) on the left side. The dialog box also displays the information for any Project that may be stored in the CLICK PLUS PLC unit (PLC) on the right side.

Click **OK** to write the project data from the **PC** to the **CLICK PLUS PLC** unit.

The **Writing...** progress window will open to allow verification that the Project is being written to the CPU. When finished, a Transfer Completed message will be displayed. Click **OK** to continue.

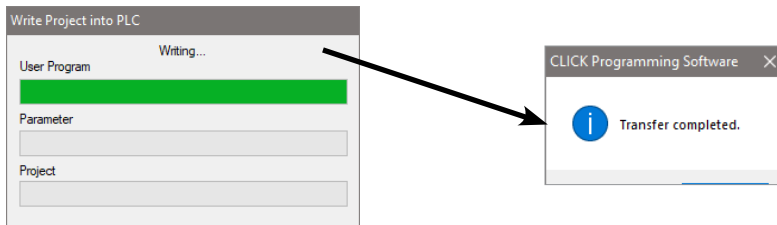

Step 9: Place PLC in RUN Mode



The next step is to place the CLICK PLUS PLC into its Run mode so that the ladder logic program will execute.

If the PLC Mode Switch was in the STOP position when the project was written to the PLC, now move the switch to RUN. The CLICK PLUS PLC is now in RUN mode and executing your ladder logic program.

If the PLC Mode Switch was in the RUN position when the project was written, the PLC Modes dialog is displayed. Click the radio button for RUN and then click the OK button. The CLICK PLUS PLC is now in RUN mode and executing your ladder logic program..

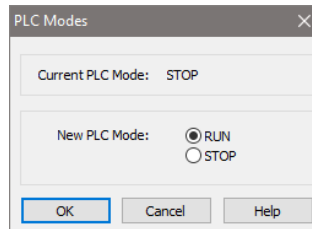
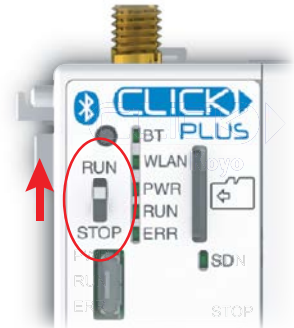

Click the radio button for RUN and then click the OK button. The CLICK PLUS PLC is now in Run mode and executing your ladder logic program.



NOTE: The PLC Modes dialog box can also be accessed by clicking on the Connection status (Offline/Run/Stop, USB Power) indicator button that is located on the toolbar.

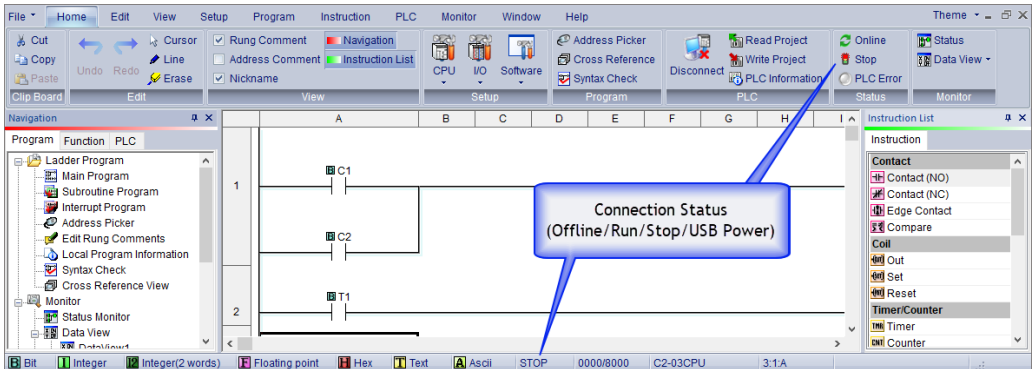

Step 10: Test Project using Data View Monitor

In this next step, use the Data View Monitor to test the ladder logic program by manually overriding the status of the internal C1 bit that was programmed. The purpose of this will be to have the C1 bit enable Timer T1. From the Navigation window on the left side of the development screen, select the Program tab, open the Data View folder under Monitor and double click on DataView1.

The Data View window is displayed.

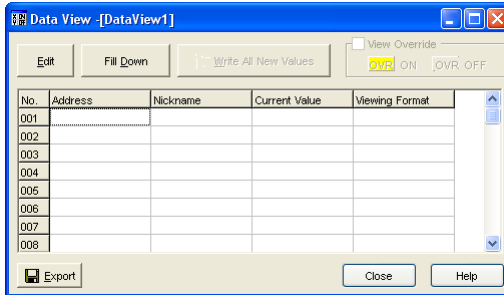
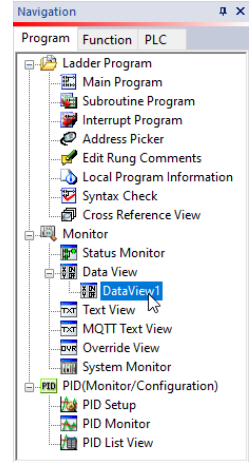

Click the Edit button and type in C1 as the Address as shown below.

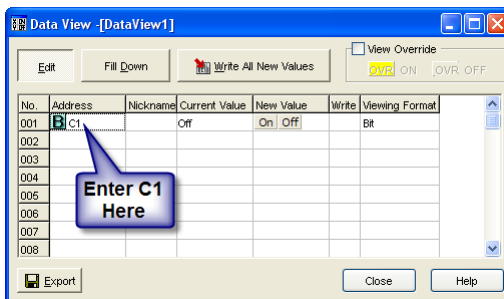

Double click the ON button in the New Value column. The Current Value of the C1 bit changes from OFF to ON. Go to Step 10: “Y001 Output On?”

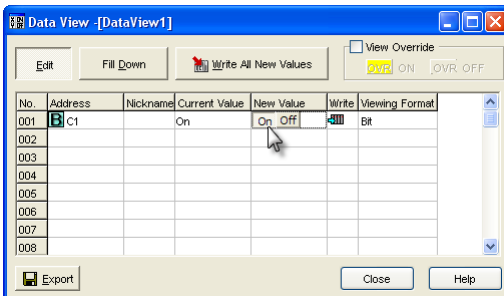

Step 11: Y001 Output On?

CLICK PLC output Y001 will turn on 5 seconds after you write the ON state to the C1 bit using Data View in the Edit mode. The location and labeling of this output will depend on your installed output modules.

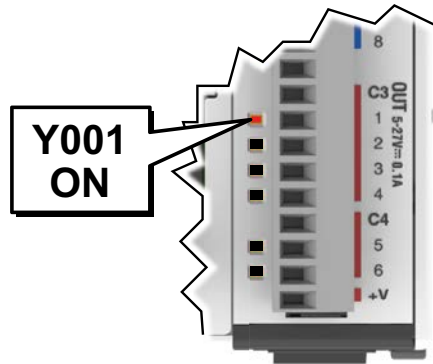

If you missed viewing the transition of the Y001 status LED from OFF to ON, write an OFF state to the C1 bit and then an ON state in the Data View Monitor to do it again.



NOTE: Also, try changing the status of the internal C2 bit. The results should be the same because the C2 bit is in parallel with the C1 bit. The ladder logic reads: "Enable timer T1, if either C1 or 'C2 is true."

Step 12: Test Project Using Remote PLC App

This step is optional. If you have one of the following CPUs, it can be remotely monitored using the CLICK Remote PLC App:

- C0-10xxx-x
- C0-11xxx-x
- C0-12xxx-x
- C2-01CPU(-2)
- C2-02CPU(-2)
- C2-03CPU(-2)

Configure your PLC for Remote Monitoring

1. From the Remote PLC menu, open the Remote PLC Setup.



2. Check the Enable Remote PLC box, then click Setup under Remote PLC Monitor Setup.

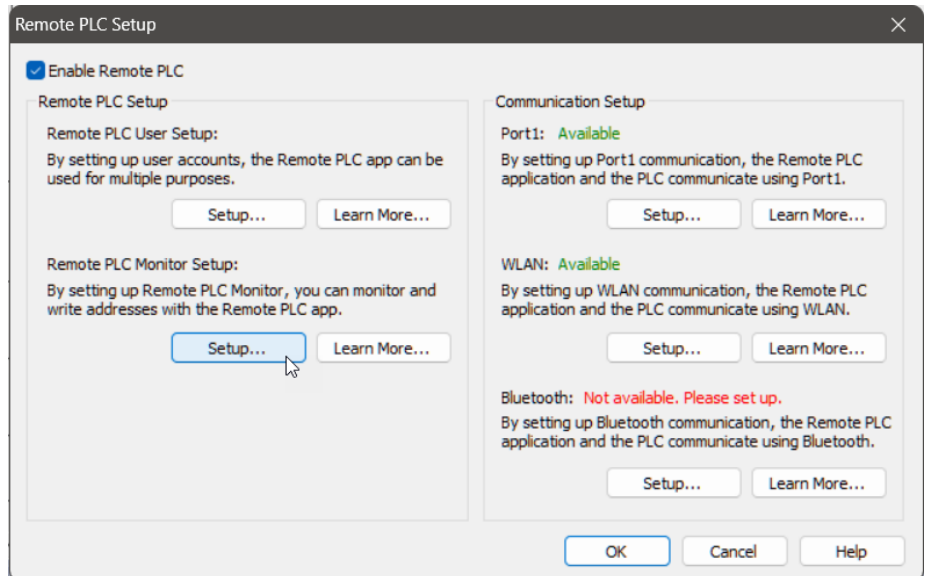

Step 12: Test Project Using Remote PLC App, (cont'd)

Set Up the Remote PLC App

1. Search for the free “Remote PLC” app by Automationdirect.com on the Apple App Store or Google Play Store, or use one of the QR codes below to install it on your mobile device.

Apple App Store



Google Play (Android)



2. Open the Remote PLC app and select Bluetooth (BLE) or Wi-Fi.
3. Select your PLC from the list of CLICK PLCs found using that connection and tap it to open the login screen for that PLC. By default log in with username “admin” and no password. We didn’t set up user logins in this test project, but any production project should use user accounts with passwords.
4. Once connected to the PLC, Choose **Remote PLC Monitor** and select the monitor name you created earlier.
5. In the Remote PLC Monitor screen, you can switch between View Mode and Edit Mode, as shown below. View Mode will show you the real-time values of the monitored addresses, and Edit Mode will let you change any writable addresses.

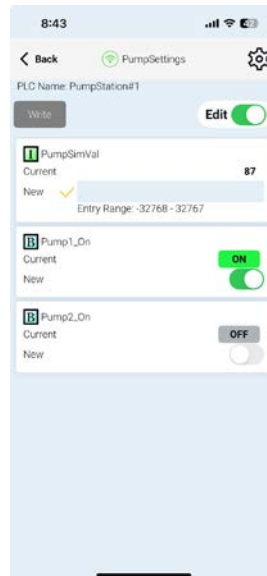
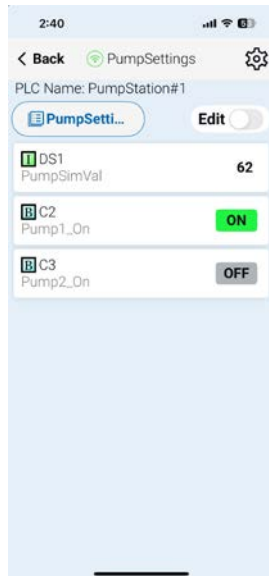

Congratulations!

You have now learned how to create, compile and transfer a ladder logic project to a CLICK PLUS PLC, and then run and test the project. There are additional instructions available for the CLICK PLUS PLC. Please refer to the programming software online help topics for details on these instructions.

Again, thank you very much for using the CLICK PLUS PLC system.

Additional Training Resources

In addition to this Getting Started chapter, there are other resources we recommend, for both the novice and pros, that will aid you in learning more about using the CLICK PLC system.

Automationdirect.com Online Video Site - <http://automationdirect.com/videos/home> is an online video tutorial site offering free on-demand video tutorials on a wide range of practical industrial products, including the CLICK PLC system.

From the Automationdirect.com home page, select (a) “Video Tutorials”. When the page opens select (b) “Programmable Controllers” on the top, lefthand topic bar for Video Filter list. Select (c) “CLICK series PLCs”. A page of CLICK specific videos will open. A search for CLICK (d) will pull up all the CLICK videos as well. The videos cover all aspects of the CLICK PLC system, from an introductory video, to communications, and programming.

The image displays two screenshots of the AutomationDirect website. The top screenshot shows the home page with a navigation menu on the left and a main banner for "AFFORDABLE CONTROLLERS FOR YOUR APPLICATION". The bottom screenshot shows the "AutomationDirect Videos" page with a search bar and a grid of video thumbnails. Red circles and letters 'a' through 'd' are overlaid on the screenshots to indicate specific steps in the navigation process.

Interconnecting Automation Online Training Courses offered at-

<http://www.interconnectingautomation.com/onlinecourses>

Interconnecting Automation offers inexpensive subscription-based online training, including CLICK PLC training.

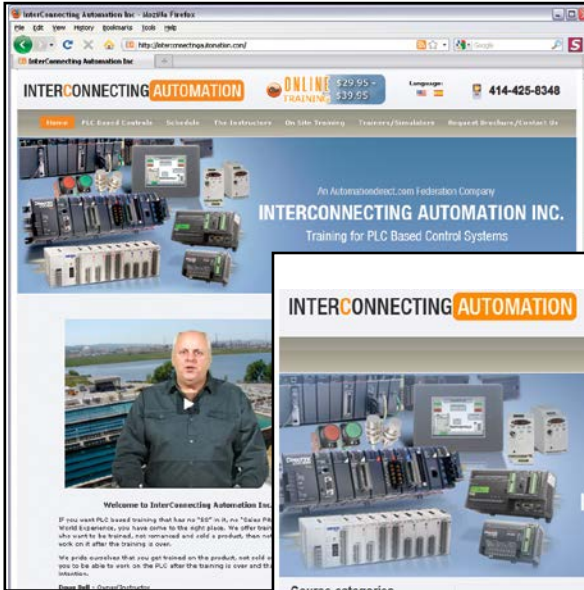

Also, a CLICK PLC Trainer is available from this web site.



SPECIFICATIONS



In This Chapter...

Overview of PLC System	2-2
Regulatory and Standards Compliance.....	2-3
CLICK PLUS PLC Units	2-4
Option Slot I/O Modules	2-6
Option Slot Intelligent Modules	2-8
Stackable I/O Modules	2-9
Power Budgeting.....	2-13
PLC Unit Specifications	2-16
Option Slot I/O Module Specifications	2-31
Option Slot Intelligent Module Specifications	2-86
Stackable I/O Module Specifications.....	2-93
Power Supply Specifications.....	2-130
Programming Software	2-133
Data Types, Memory, and Numbering System	2-134
PLC Operation.....	2-138
Accessories.....	2-142

Overview of PLC System

The CLICK PLC family of components is designed to combine practical PLC features in a compact and expandable design, with a simple-to-use philosophy. A powered CLICK PLUS PLC unit by itself can be used as a complete PLC system with up to two Option Slot modules, or the system can be expanded with the addition of up to eight Stackable I/O modules. The CLICK PLC system does not require a mounting base. The CLICK PLUS PLC and I/O modules are connected together via an expansion port on the right side of the PLC case. A variety of I/O modules is available for flexible and optimal system configuration. The CLICK PLUS PLC supports a very simple but useful instruction set. There are 21 easy-to-use instructions that cover most applications that are suitable for this class of PLC.

Use a CLICK PLUS PLC unit as a stand-alone controller with Option Slot I/O...

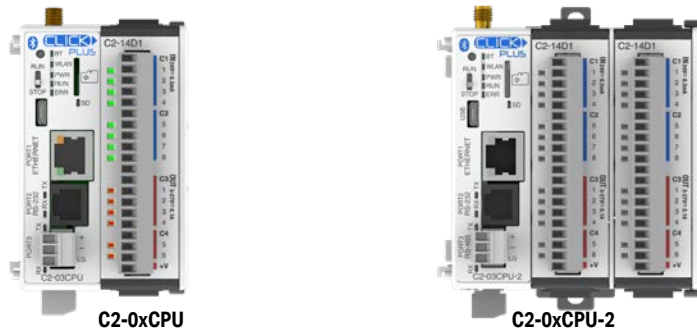

...or, expand the system by installing up to eight additional I/O modules.

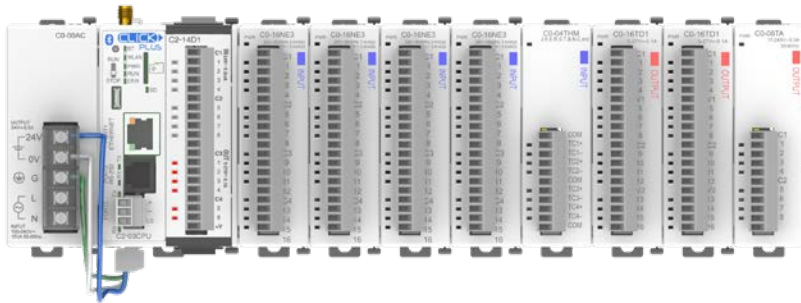

NOTE: It is not necessary to use the CLICK power supply with a CLICK PLUS PLC. An alternate, regulated, properly-sized 24VDC power source can be used to power the PLC and can also provide 24VDC to any optional I/O modules used in the CLICK PLUS PLC hardware configuration. Please refer to the Power Budgeting section later in this chapter for details on choosing the correct size power supply.

Regulatory and Standards Compliance

FCC and ISED(Canada)

Per FCC 15.19(a)(3) and (a)(4) This device complies with part 15 of the FCC Rules. Operation is subject to the following two conditions: (1) This device may not cause harmful interference, and (2) this device must accept any interference received, including interference that may cause undesired operation.

Per FCC 15.21, changes or modifications not expressly approved by the JTEKT Electronics Corporation could void the user's authority to operate the equipment.

This device complies with Industry Canada license-exempt RSS standard(s). Operation is subject to the following two conditions: (1) this device may not cause interference, and (2) this device must accept any interference, including interference that may cause undesired operation of the device.

Cet appareil est conforme à la norme RSS Industrie Canada exempt de licence. Son fonctionnement est soumis aux deux conditions suivantes: (1) cet appareil ne doit pas provoquer d'interférences et (2) cet appareil doit accepter toute interférence, y compris les interférences pouvant causer un mauvais fonctionnement du dispositif.

CLICK PLUS PLC Units

All CLICK PLUS PLC units offer the same instruction set and support CLICK PLUS Option Slot modules as well as all CLICK stackable I/O modules. The six types of PLC units available are listed in the table below.

PLC	Communication Ports						Micro SD Slot	Battery Backup	RUN time Edit
	USB	Ethernet (Port 1)	RS-232 (Port 2)	RS-485 (Port 3)	Bluetooth	WLAN			
C2-01CPU C2-01CPU-2		Yes (10/100)	Yes	None	None	None	None		
C2-02CPU C2-02CPU-2	Yes (microB)	None	None	None	Yes (external antenna required)	Yes (external antenna required)	None	Yes	Yes
C2-03CPU C2-03CPU-2		Yes (10/100)	Yes	Yes			Yes		

CLICK PLUS PLC Units

The layout of the CLICK PLUS external features is illustrated below using the C2-03CPU-2 model. Some features are not present in other models as outlined in the table above.

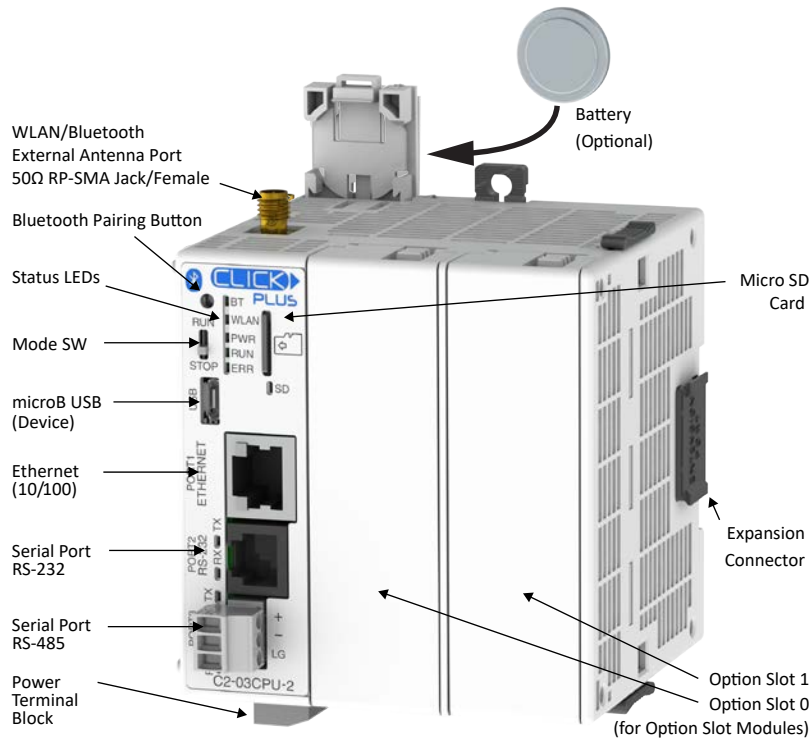

NOTE: High-speed Inputs and Outputs are only available on Slot 0.

CPU is shown with optional C2-FILL Option Slot Covers installed.

Memory

All CLICK PLUS PLC units have a non-volatile FLASH ROM to store the downloaded ladder program and project file. The FLASH ROM will retain the ladder program even with power removed from the PLC module.

The CLICK PLUS PLC units make use of data registers to store values and conditions that are used during program execution. This data is stored in the SRAM memory. It is volatile memory that is backed up by a super capacitor. This super capacitor is a special type of capacitor designed to provide power to volatile memory like the SRAM when the power to the PLC is off. However, it will not back up the memory for an extended time. In the case of the CLICK PLUS PLC, the super capacitor will back up the SRAM for approximately 1 hour after the power is shut off. Once the super capacitor is discharged, all data in the SRAM is cleared.

To prevent the loss of SRAM memory during power down, the CLICK PLUS PLCs have a battery backup feature that will retain data in the SRAM for three years. Use part number D0-MC-BAT as the replacement battery.

Refer to the PLC Unit Specifications section later in this chapter for more PLC information.



NOTE: The SD Card Memory available on the C2-03CPU and C2-03CPU-2 is only used for data logging. The PLC project and SRAM memory data are not stored on the SD Card.

Option Slot I/O Modules

The CLICK PLUS PLCs have one or two internal expansion slots (Option Slots). The first Option Slot (Slot 0) has access to a high-speed bus. A variety of Option Slot I/O modules are available, as listed below. Complete I/O module specifications and wiring diagrams can be found later in this chapter.

CLICK PLUS Option Slot I/O Modules					
Part Number	Corresponding CLICK C0 CPU	Discrete Input Types	Discrete Output Types	Analog Input Types	Analog Output Types
C2-14D1	C0-11DD1E-D	8 DC (sink/source) 8 points High-Speed**	6 DC (sink) 3 points High-Speed**	None	None
C2-14D2	C0-11DD2E-D		6 DC (source) 3 points High-Speed**		
C2-14DR	C0-11DRE-D		6 Relay		
C2-14AR	C0-11ARE-D				
C2-14TTL	NA		8 TTL (sink/source) 8 points High-Speed**		
C2-08D1-4VC*	C0-12DD1E-D	4 DC (sink/source) 4 points High-Speed**	4 DC (sink) 2 points High-Speed**	2 channel; voltage (0-5 VDC) / current (4-20 mA); selectable separately per channel, 12-bit	2 channel; voltage (0-5 VDC) / current (4-20 mA); selectable separately per channel, 12-bit
C2-08D2-4VC*	C0-12DD2E-D		4 DC (source) 2 points High-Speed**		
C2-08DR-4VC*	C0-12DRE-D		4 relay		
C2-08AR-4VC*	C0-12ARE-D				
<p>* These four Option Slot modules require that you select analog I/O as voltage or current type in the CLICK programming software. See the Analog I/O Configuration section in Chapter 3.</p> <p>** For high-speed inputs and outputs, the Option Slot Module must be installed in Slot 0.</p>					
Table continued on next page.					

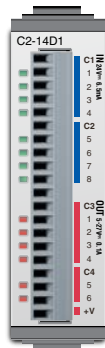

C2-14xx

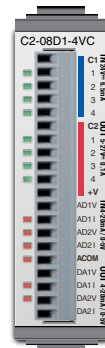

C2-08xx-4VC

CLICK PLUS Option Slot I/O Modules (continued)					
Part Number	Corresponding CLICK C0 CPU	Discrete Input Types	Discrete Output Types	Analog Input Types	Analog Output Types
C2-08D1-6C	C0-12DD1E-1-D	4 DC (sink/source) 4 points High-Speed**	4 DC (sink) 2 points High-Speed**	4 channel; current (0–20 mA), 12-bit	2 channel; current (4–20 mA), 12-bit
C2-08D2-6C	C0-12DD2E-1-D		4 DC (source) 2 points High-Speed**		
C2-08DR-6C	C0-12DRE-1-D		4 relay		
C2-08AR-6C	C0-12ARE-1-D		4 AC		
C2-08D1-6V	C0-12DD1E-2-D	4 DC (sink/source) 4 points High-Speed**	4 DC (sink) 2 points High-Speed**	4 channel; voltage (0–10 VDC), 12-bit	2 channel; voltage (0–10 VDC), 12-bit
C2-08D2-6V	C0-12DD2E-2-D		4 DC (source) 2 points High-Speed**		
C2-08DR-6V	C0-12DRE-2-D		4 relay		
C2-08AR-6V	C0-12ARE-2-D		4 AC		

* These four Option Slot modules require that you select analog I/O as voltage or current type in the CLICK programming software. See the Analog I/O Configuration section in Chapter 3.

** For high-speed inputs and outputs, the Option Slot Module must be installed in Slot 0.

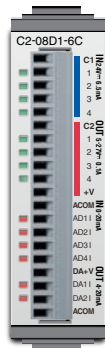

C2-08xx-6C

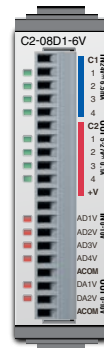

C2-08xx-6V

Option Slot Intelligent Modules

In addition to I/O modules, the Option Slots on CLICK PLUS PLCs can accept Option Slot Intelligent Modules. These comprise the C2-DCM communications module, C2-NRED Node-RED module and C2-OPCUA OPC UA server module, as shown in the table below. Complete Intelligent Module specifications and wiring diagrams can be found later in this chapter. Option Slot Intelligent Modules facilitate expansion of the capabilities of the CLICK PLUS system without requiring replacement of your existing CLICK PLUS CPU.

CLICK PLUS Option Slot Intelligent Modules	
Part Number	Description
C2-DCM	CLICK PLUS communication module, Modbus RTU and ASCII, 2 ports, (2) RS-232/RS-485 (6-pin terminal) port(s). For use with all CLICK PLUS PLCs. (2) C2-6TB terminal blocks included.
C2-NRED	CLICK PLUS Node-RED module, Node-RED and JavaScript, microSD card slot, (1) microB-USB and (1) Ethernet 10/100Base-T (RJ45) port(s). For use with all CLICK PLUS PLCs.
C2-OPCUA	CLICK PLUS communication module, OPC-UA Server and SNTTP Client, 1 port, (1) microB-USB and (1) Ethernet 10/100Base-T (RJ45) port(s). For use with all CLICK PLUS PLCs.

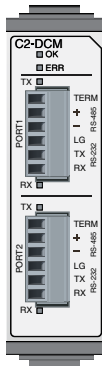

C2-DCM

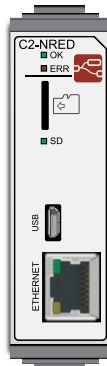

C2-NRED



C2-OPCUA

Stackable I/O Modules

A variety of I/O modules is available for the CLICK PLC System. Up to 8 I/O modules can be connected to a CLICK PLC unit to expand the system I/O count and meet the needs of a specific application. Complete I/O module specifications and wiring diagrams can be found later in this chapter. Here are the I/O modules that are supported by the CLICK PLC system.

Discrete Input Modules

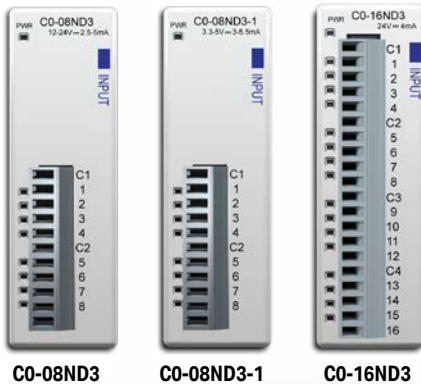

Discrete Input Modules		
Part Number	Input Type	Voltage Ratings
CO-08ND3	8 DC (Sink/Source)	12-24 VDC
CO-08ND3-1	8 DC (Sink/Source)	3.3-5 VDC
CO-16ND3	16 DC (Sink/Source)	24VDC
CO-08NE3	8 AC/DC (Sink/Source)	24 VAC/VDC
CO-16NE3	16 AC/DC (Sink/Source)	24 VAC/VDC
CO-08NA	8 AC	100-120 VAC

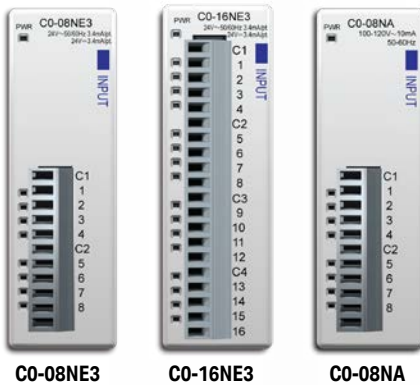

Specialty Modules

Specialty Modules		
Part Number	Input Type	Voltage Ratings
CO-08SIM	8 Toggle Switch	N/A
CO-04POT	4 Potentiometer	N/A

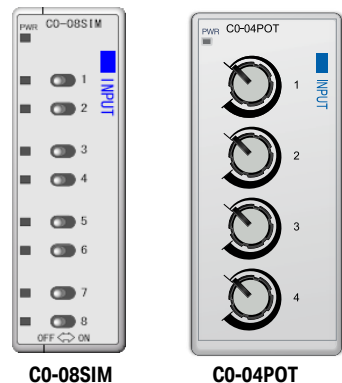

Discrete Output Modules

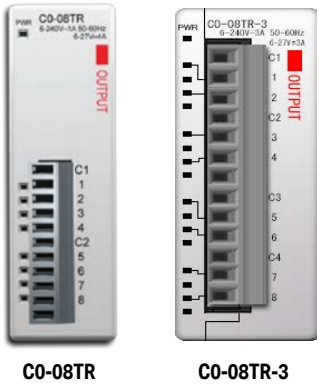
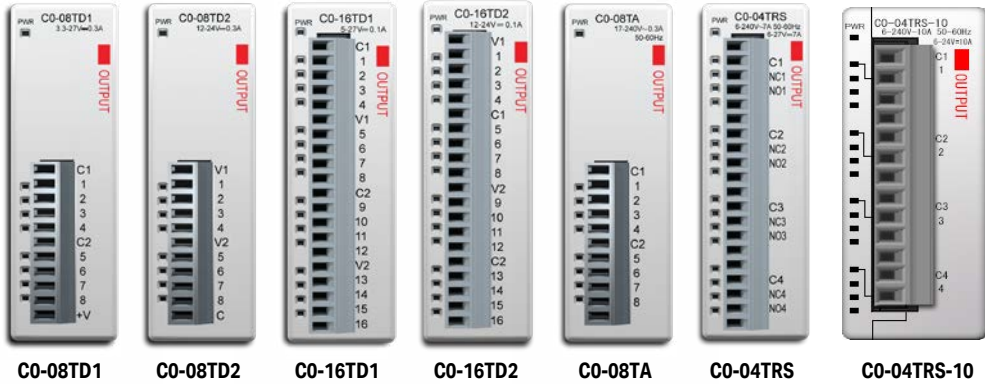

Discrete Output Modules		
Part Number	Output Type	Voltage/Current Ratings
CO-08TD1	8 DC (Sink)	3.3-27 VDC / 0.3 A
CO-08TD2	8 DC (Source)	12-24 VDC / 0.3 A
CO-16TD1	16 DC (Sink)	5-27 VDC / 0.1 A
CO-16TD2	16 DC (Source)	12-24 VDC / 0.1 A
CO-08TA	8 AC	17-240 VAC / 0.3 A
CO-04TRS	4 Relay	6-27 VDC / 7A 6-240 VAC / 7A
CO-04TRS-10	4 Relay	6-24 VDC / 10A 6-240 VAC / 10A
CO-08TR	8 Relay	6-27 VDC / 1A 6-240 VAC / 1A
CO-08TR-3	8 Relay	6-27 VDC / 3A 6-240 VAC / 3A

Discrete Combo I/O Modules

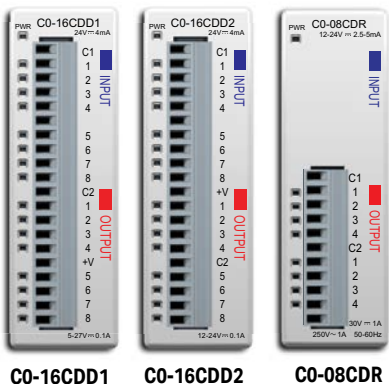

Discrete Combo I/O Modules				
Part Number	Input Type	Input Voltage	Output Type	Output Voltage / Current Ratings
CO-16CDD1	8 DC (sink/source)	24VDC	8 DC (sink)	5-27 VDC / 0.1 A
CO-16CDD2	8 DC (sink/source)	24VDC	8 DC (source)	12-24 VDC / 0.1 A
CO-08CDR	4 DC (sink/source)	12-24 VDC	4 (relay)	6.25-24 VDC / 1A 6-240 VAC / 1A

Analog Input Modules

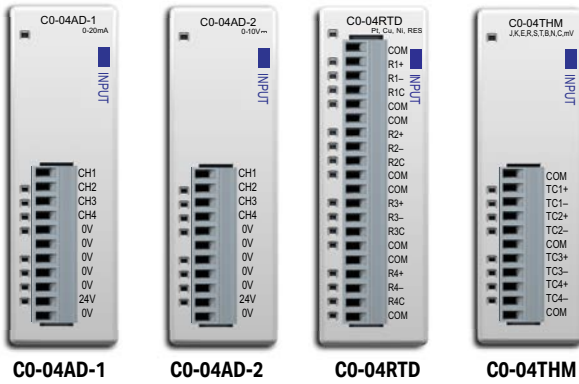

Analog Input Modules		
Part Number	Analog Input Types	External Power Required
CO-04AD-1	4 channel, current (0-20 mA), 13-bit	24VDC
CO-04AD-2	4 channel, voltage (0-10 V), 13-bit	24VDC
CO-04RTD	4 channel RTD input (0.1 degree °C/°F resolution), or resistive input (0-3125 Ω, 0.1 Ω or 0.01 Ω resolution)	None
CO-04THM	4 channel thermocouple input (0.1 degree °C/°F resolution), or voltage input (-156.25 mV to 1.25 V, 16-bit)	None

Analog Output Modules

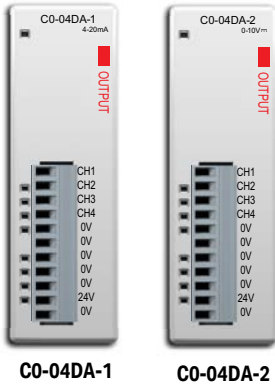

Analog Output Modules		
Part Number	Analog Output Types	External Power Required
CO-04DA-1	4 channel, current sourcing (4-20 mA), 12-bit	24VDC
CO-04DA-2	4 channel, voltage (0-10 V), 12-bit	24VDC

Analog Combo I/O Modules

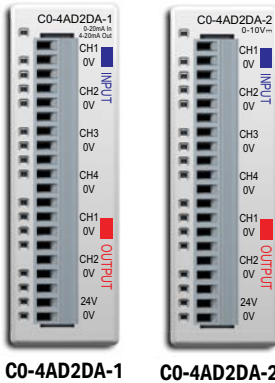

Analog Combo I/O Modules			
Part Number	Analog Input Type	Analog Output Type	External Power Required
CO-4AD2DA-1	4 channel, current (0-20 mA), 13-bit	2 channel, current sourcing (4-20 mA), 12-bit	24VDC
CO-4AD2DA-2	4 channel, voltage (0-10 V), 13-bit	4 channel, voltage (0-10 V), 12-bit	24VDC

Power Supply

Two different 24VDC power supplies are available for the CLICK PLC family. They are designed to attach to the left side of the CLICK PLC, creating a compact footprint. They are identical except for the output current rating. The 24VDC power is wired from the DC output terminals of the power supply to a removable power terminal block located on the bottom of the CLICK PLC unit.

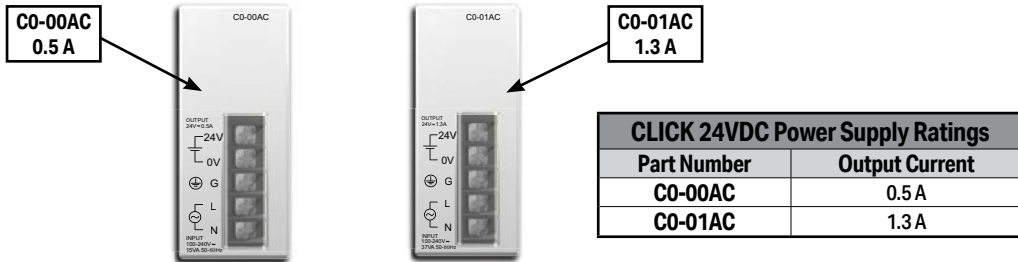

C0-00AC

The C0-00AC is a low-cost solution for applications requiring only minimal I/O and power consumption. This power supply will not support a fully-populated CLICK PLC system with all possible I/O module combinations. Please see Power Budgeting section of this chapter for details.

C0-01AC

The C0-01AC is designed to support a fully-populated CLICK PLC system with all possible I/O module combinations with no concerns of exceeding the power budget.

Please refer to the Power Supply Specifications section later in this chapter for specification details.



NOTE: It is not mandatory to use one of the above CLICK power supplies for the CLICK PLC system. A properly-sized and rated 24VDC power supply, such as some of those offered by Automationdirect.com, can also be used to power a CLICK PLC system.



12 VDC-to-24VDC Converter		
Part Number	Input Voltage	Output Current
PSP24-DC12-1	9.5-18 VDC	1.0 A @ 24VDC

PSP24-DC12-1

With this DC-DC converter you can operate the CLICK PLC with 12VDC input power.

To select a power supply to use with your CLICK PLC system, you need to consider the total PLC system's power budget. Please refer to the Power Budget section of this chapter for details.

Power Budgeting

What is Power Budgeting?

There are two areas that need to be considered when determining the power required to operate a CLICK PLUS PLC system. The first is the power required internally by the CLICK PLUS PLC. This includes the internal logic-side power that the PLC provides to its Option Slot modules, connected I/O modules that are powered through the PLC expansion port, and any device, such as a C-more Micro-Graphic panel, that is powered through one of the PLC's communication ports.

The second area is the power required by all externally-connected I/O devices. This should be viewed as the field-side power required. The field-side power is dependent on the voltage used for a particular input or output device as it relates to the wired I/O point and on the calculated load rating of the connected device

It is strongly recommended that the power source for the logic side be separate from the power source for the field side to help eliminate possible electrical noise.

Be aware that the CLICK PLUS PLC sinking DC output points require a sustained voltage to work with their output drivers. This includes the C0-08TD1 and C0-16TD1 output modules. It is recommended that this voltage be provided from the field-side power source.

The CLICK PLUS PLC operates from a 24VDC power source. The 24VDC power source can be provided by an optional CLICK PLC unit power supply (C0-00AC or C0-01AC) or one of our standard industrial 24VDC power supplies.



CLICK 24VDC Power Supply
C0-00AC or C0-01AC



Alternative 24VDC Power Supply
Example: PSP24-DC12-1

Visit www.automationdirect.com for the complete line.

Choice of the power source for the connected I/O devices is dependent on the voltage rating of the devices and the type of CLICK I/O module that is being used.

Power Budgeting requires the calculation of the total current that the 24VDC power source needs to provide to the CLICK PLUS PLC unit logic side and also a separate calculation of the total current required from all devices operating from the field side of the CLICK PLC system.

Refer to the following pages which includes tables listing the CLICK PLUS PLC and I/O module current requirements, plus a power budgeting example.

Power Budget Calculation

The following table shows the current consumption required for both the logic side and field side of the CLICK units.

PLC Current Consumption (mA)		
Part Number	Power Budget 24VDC (logic side)	External 24VDC (field side)
PLC CPU Units		
C2-01CPU	110	0
C2-02CPU	105	0
C2-03CPU	130	0
C2-01CPU-2	120	0
C2-02CPU-2	115	0
C2-03CPU-2	140	0
Option Slot I/O Modules		
C2-14D1	50	60
C2-14D2	50	0
C2-14DR	75	0
C2-14AR	75	0
C2-14TTL	220	0
C2-08D1-4VC	80	60
C2-08D2-4VC	80	0
C2-08DR-4VC	100	0
C2-08AR-4VC	100	0
C2-08D1-6C	80	60
C2-08D2-6C	80	0
C2-08DR-6C	100	0
C2-08AR-6C	100	0
C2-08D1-6V	80	60
C2-08D2-6V	80	0
C2-08DR-6V	100	0
C2-08AR-6V	100	0
Option Slot Intelligent Modules		
C2-DCM	60	0
C2-NRED	125	0
C2-OPCUA	125	0

I/O Module Current Consumption (mA)		
Part Number	Power Budget 24VDC (logic side)	External 24VDC (field side)
Discrete Input Modules		
C0-08ND3	30	0
C0-08ND3-1	30	0
C0-16ND3	40	0
C0-08NE3	30	0
C0-16NE3	40	0
C0-08NA	30	0
Discrete Output Modules		
C0-08TD1	50	15
C0-08TD2	50	0
C0-16TD1	80	100
C0-16TD2	80	0
C0-08TA	80	0
C0-04TRS	100	0
C0-04TRS-10	120	0
C0-08TR	100	0
C0-08TR-3	90	0
Discrete Combo I/O Modules		
C0-16CDD1	80	50
C0-16CDD2	80	0
C0-08CDR	80	0
Specialty Modules		
C0-08SIM	50	0
C0-04POT	30	0
Analog Input Modules		
C0-04AD-1	20	65
C0-04AD-2	23	65
C0-04RTD	25	0
C0-04THM	25	0
Analog Output Modules		
C0-04DA-1	20	145
C0-04DA-2	20	85
Analog Combo I/O Modules		
C0-4AD2DA-1	25	75
C0-4AD2DA-2	20	65
C-more Micro-Graphic Panel (Monochrome only)		
All p/n	90	0

Power Budget Example

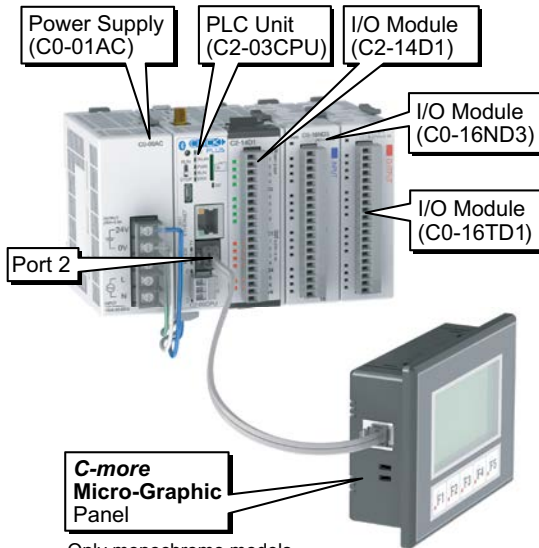

Only monochrome models can be powered from port 2.

Add the current consumption for each module in the system as shown in this example.

Current Consumption (mA)		
Part Number	Power Budget 24VDC (logic side)	External 24VDC (field side)
C2-03CPU	130	0
C2-14D1	50	60
C0-16ND3	40	0
C0-16TD1	80	100
C-more Micro	90	0
Total:	390	160 *

* Plus calculated load of connected I/O devices.

Power Budgeting using the CLICK Programming Software

The following example shows the logic-side current consumption as calculated in the System Configuration Setup section of the CLICK Programming Software. Based on the amperage rating of the power supply selected in the first column, your power budget is calculated by subtracting each consecutive module's power consumption from the total available power budget. If you exceed the maximum allowable power consumption, the power budget row fills in red.

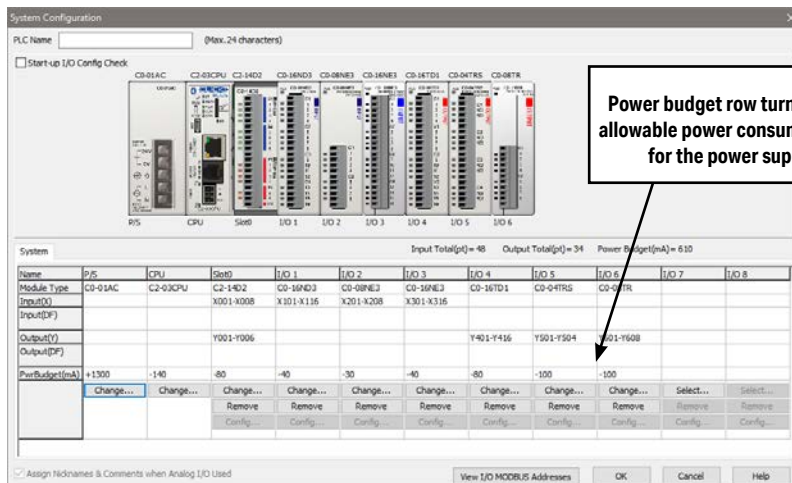

Power budget row turns red if maximum allowable power consumption is exceeded for the power supply selected.

PLC Unit Specifications

General Specifications for all CLICK PLUS CPUs

CLICK PLUS PLC Unit General Specifications	
Operating Temperature	32°F to 131°F (0°C to 55°C)
Storage Temperature	-4°F to 158°F (-20°C to 70°C) IEC 60068-2-1 (Test Ab, Cold) IEC 60068-2-2 (Test Bb, Dry Heat) IEC 60068-2-14 (Test Na, Thermal Shock)
Ambient Humidity	30% to 95% relative humidity (non-condensing)
Altitude	Up to 2,000m
Environmental Air	No corrosive gases The level for the environmental pollution is 2 (UL840)
Environment	For Indoor Use Only
Vibration	IEC60068-2-6 (Test Fc) 5-9Hz: 3.5mm amplitude, 9-150Hz 1.0G 10 sweep cycles per axis on each of 3 mutually perpendicular axes.
Shock	IEC60068-2-27 (Test Ea) 15G peak, 11ms duration, 3 shocks in each direction per axis, on 3 mutually perpendicular axes.
Voltage Withstand (Dielectric)	1000VAC, 1 minute (between G and 24V IN)
Insulation Resistance	500VDC, 10M ohm (between G and 24V IN)
Noise Immunity	<EN61131-2> EN61000-4-2 (ESD): 4kV (Contact Discharge) 8kV (Air Discharge) EN61000-4-3 (RFI): 10V/m (80MHz-1GHz), 3V/m (1.4GHz-2.0GHz) 1V/m(2.0GHz-2.7GHz) EN61000-4-4 (FTB) : 2kV, positive/negative, 5kHz (DC Power Port) 1kV, positive/negative, 5kHz (I/O and Communication Port) EN61000-4-5 (Surge): 0.5kV/1kV line to line 0.5kV/1kV line to earth EN61000-4-6 (Conducted): 10V, 0.15MHz - 80MHz EN61000-4-8 (Power frequency magnetic field immunity) : 30A/m <Local Test> Impulse Immunity: 1000V @ 1uS pulse
Emissions	EN55011 Class A (Radiated RF emission)
Agency Approvals	UL61010 (File No. E157382, E316037); CE (EN61131-2); CUL Canadian C22.2
Radio Standards	FCC part15C (US), RED Article3.2 (CE), IC RSS-247 (Canada), MIC Item 19 of Article 2-1 (Japan), AS/NZS 4268 (Australia/New Zealand)
Other	RoHS 2011/65/EU Amendment (EU)2015/863 Bluetooth SIG, SD associate

PLC Unit Specifications, continued

C2-01CPU



C2-01CPU-2



CLICK PLUS C2-01CPU and C2-01CPU-2 PLC Unit Specifications	
Control Method	Stored Program/Cyclic execution method
I/O Numbering System	Fixed in Decimal
Ladder Memory (steps)	8000
Total Data Memory (words)	8000
Contact Execution (boolean)	< 0.2 μs
Typical Scan (1k boolean)	< 1ms
RLL Ladder Style Programming	Yes
Run Time Edits	Yes
Scan	Variable / fixed
PLC Mode Switch	1 (RUN/STOP)
FLASH Memory	Standard on PLC
Protocol	Modbus RTU (master/slave) and ASCII (in/out), Modbus TCP (client server), EtherNet/IP Implicit and Explicit (adapter server)
MQTT	Publisher: 4 Publishers, 3 blocks each Subscriber: 10 blocks
Data Logging	N/A
CLICK Programming Software	Yes (Windows)
Number of Instructions Available	21
Control Relays	2000
System Control Relays	1000
Timers	500
Counters	250
Interrupt	Yes (external: 8 / timed: 4)
Subroutines	Yes
For/Next Loops	Yes
Math (Integer and Hex)	Yes
Drum Sequencer Instruction	Yes
Internal Diagnostics	Yes
Password Security	Yes
System Error Log	Yes
User Error Log	No
Memory Backup	Super Capacitor + Battery
Battery Backup	Yes (battery part # DO-MC-BAT)
Calendar/Clock	Yes

PLC Unit Specifications, continued

CLICK PLUS C2-01CPU and C2-01CPU-2 PLC Unit Specifications			
		C2-01CPU	C2-01CPU-2
I/O Slot	Internal I/O	N/A (Optional)	
	Option Slot Support	Yes	
	Stackable I/O	Yes (max. 8 modules)	
Com. Ports	USB Port (Programming)	Yes (Device) (For programming and providing 5VDC power, microB USB)	
	Ethernet (RJ45)	Yes (10/100)	
	Serial Port RS-232 (RJ12)	Yes	
	Serial Port RS-485 (Terminal Block)	None	
	WLAN	None	
	Bluetooth	None	
Status Indicators	WLAN Status LED	None	
	Bluetooth Status LED	None	
	CPU Status LED	3 (PWR/RUN/ERR)	
	Ethernet Status LED	2 (LINK/ACT 10/100)	
	Serial Status LED	2 (TX/RX)	
	SD Card Status LED	None	
Other	Micro SD Card Slot (SDHC Compatible)	None	
Power	Nominal Input Voltage	24VDC (4-pin terminal block)	
	Operating Voltage Range	24VDC, Class 2 or SELV (Safety Extra-Low Voltage) or Limited Energy Circuit power supply	
	Input Voltage Range	20.0 – 28.0 VDC	
	Maximum Inrush Current	30A @ 1ms	
	Power Consumption*	20W	22W
	Acceptable External Power Drop	Max 10ms (AC Power Failure with C0-00AC or C0-01AC)	
	Current Required	110mA	120mA
	Fuse	No	
	External Fuse Recommended	No	
	Polarity Protection	Power input is reverse polarity protected	
	USB Supply	5VDC (via USB programming port)	
Communication Port & Terminal Block Replacement		N/A	
24VDC Power Terminal Block Replacement		AutomationDirect p/n C0-4TB	
Antenna Requirements		N/A	
Weight		3.5 oz [99g]	4.0 oz [114g]

* Power consumption shown is the maximum power consumption with the maximum number of I/O modules attached.

PLC Unit Specifications, continued

C2-02CPU

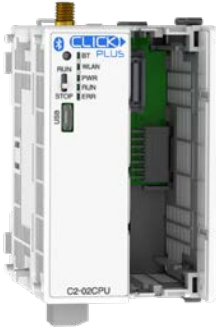

C2-02CPU-2



CLICK PLUS C2-02CPU and C2-02CPU-2 PLC Unit Specifications	
Control Method	Stored Program/Cyclic execution method
I/O Numbering System	Fixed in Decimal
Ladder Memory (steps)	8000
Total Data Memory (words)	8000
Contact Execution (boolean)	< 0.2 μs
Typical Scan (1k boolean)	< 1ms
RLL Ladder Style Programming	Yes
Run Time Edits	Yes
Scan	Variable / fixed
PLC Mode Switch	1 (RUN/STOP)
FLASH Memory	Standard on PLC
Protocol	Modbus RTU (master/slave) and ASCII (in/out), Modbus TCP (client server)
MQTT	Publisher: 4 Publishers, 3 blocks each Subscriber: 10 blocks
Data Logging	N/A
CLICK Programming Software	Yes (Windows)
Number of Instructions Available	21
Control Relays	2000
System Control Relays	1000
Timers	500
Counters	250
Interrupt	Yes (external: 8 / timed: 4)
Subroutines	Yes
For/Next Loops	Yes
Math (Integer and Hex)	Yes
Drum Sequencer Instruction	Yes
Internal Diagnostics	Yes
Password Security	Yes
System Error Log	Yes
User Error Log	No
Memory Backup	Super Capacitor + Battery
Battery Backup	Yes (battery part # D0-MC-BAT)
Calendar/Clock	Yes

PLC Unit Specifications, continued

CLICK PLUS C2-02CPU and C2-02CPU-2 PLC Unit Specifications			
		C2-02CPU	C2-02CPU-2
I/O Slot	Internal I/O	N/A (Optional)	
	Option Slot Support	Yes	
	Stackable I/O	Yes (max. 8 modules)	
Com. Ports	USB Port (Programming)	Yes (Device) (For programming and providing 5VDC power, microB USB)	
	Ethernet (RJ45)	None	
	Serial Port RS-232 (RJ12)	None	
	Serial Port RS-485 (Terminal Block)	None	
	WLAN	Yes (RP-SMA connection for optional external antenna, shared)	
	Bluetooth		
Status Indicators	WLAN Status LED	1	
	Bluetooth Status LED	1	
	CPU Status LED	3 (PWR/RUN/ERR)	
	Ethernet Status LED	None	
	Serial Status LED	None	
	SD Card Status LED	None	
Other	Micro SD Card Slot (SDHC Compatible)	None	
Power	Nominal Input Voltage	24VDC (4-pin terminal block)	
	Operating Voltage Range	24VDC, Class 2 or SELV (Safety Extra-Low Voltage) or Limited Energy Circuit power supply	
	Input Voltage Range	20.0 – 28.0 VDC	
	Maximum Inrush Current	30A @ 1ms	
	Power Consumption*	20W	22W
	Acceptable External Power Drop	Max 10ms (AC Power Failure with C0-00AC or C0-01AC)	
	Current Required	105mA	115mA
	Fuse	No	
	External Fuse Recommended	No	
	Polarity Protection	Power input is reverse polarity protected	
	USB Supply	5VDC (via USB programming port)	
Communication Port & Terminal Block Replacement		N/A	
24VDC Power Terminal Block Replacement		AutomationDirect p/n C0-4TB	
Antenna Requirements		2.4 GHz antenna, RP-SMA connector (AutomationDirect p/n SE-ANT250 or SE-ANT210)	
Weight		3.3 oz [94g]	3.8 oz [109g]

* Power consumption shown is the maximum power consumption with the maximum number of I/O modules attached.

PLC Unit Specifications, continued

C2-03CPU



C2-03CPU-2



CLICK PLUS C2-03CPU and C2-03CPU-2 PLC Unit Specifications	
Control Method	Stored Program/Cyclic execution method
I/O Numbering System	Fixed in Decimal
Ladder Memory (steps)	8000
Total Data Memory (words)	8000
Contact Execution (boolean)	< 0.2 μs
Typical Scan (1k boolean)	< 1ms
RLL Ladder Style Programming	Yes
Run Time Edits	Yes
Scan	Variable / fixed
PLC Mode Switch	1 (RUN/STOP)
FLASH Memory	Standard on PLC
Protocol	Modbus RTU (master/slave) and ASCII (in/out), Modbus TCP (client server), EtherNet/IP Implicit and Explicit (adapter server)*
MQTT	Publisher: 4 Publishers, 3 blocks each Subscriber: 10 blocks
Data Logging	Time, Date, 16 Addresses
CLICK Programming Software	Yes (Windows)
Number of Instructions Available	21
Control Relays	2000
System Control Relays	1000
Timers	500
Counters	250
Interrupt	Yes (external: 8 / timed: 4)
Subroutines	Yes
For/Next Loops	Yes
Math (Integer and Hex)	Yes
Drum Sequencer Instruction	Yes
Internal Diagnostics	Yes
Password Security	Yes
System Error Log	Yes
User Error Log	No
Memory Backup	Super Capacitor + Battery
Battery Backup	Yes (battery part # D0-MC-BAT)
Calendar/Clock	Yes

* EtherNet/IP available on the Ethernet RJ45 port only. Not available over Wi-Fi.

PLC Unit Specifications, continued

CLICK PLUS C2-03CPU and C2-03CPU-2 PLC Unit Specifications			
		C2-03CPU	C2-03CPU-2
I/O Slot	Internal I/O	N/A (Optional)	
	Option Slot Support	Yes	
	Stackable I/O	Yes (max. 8 modules)	
Com. Ports	USB Port (Programming)	Yes (Device) (For programming and providing 5VDC power, microB USB)	
	Ethernet (RJ45)	Yes (10/100)	
	Serial Port RS-232 (RJ12)	Yes	
	Serial Port RS-485 (Terminal Block)	Yes	
	WLAN	Yes (RP-SMA connection for optional external antenna, shared)	
	Bluetooth		
Status Indicators	WLAN Status LED	1	
	Bluetooth Status LED	1	
	CPU Status LED	3 (PWR/RUN/ERR)	
	Ethernet Status LED	2 (LINK/ACT 10/100)	
	Serial Status LED	2 (TX/RX)	
	SD Card Status LED	1	
Other	Micro SD Card Slot (SDHC Compatible)	YES	
Power	Nominal Input Voltage	24VDC (4-pin terminal block)	
	Operating Voltage Range	24VDC, Class 2 or SELV (Safety Extra-Low Voltage) or Limited Energy Circuit power supply	
	Input Voltage Range	20.0 – 28.0 VDC	
	Maximum Inrush Current	30A @ 1ms	
	Power Consumption*	20W	22W
	Acceptable External Power Drop	Max 10ms (AC Power Failure with C0-00AC or C0-01AC)	
	Current Required	130mA	140mA
	Fuse	No	
	External Fuse Recommended	No	
	Polarity Protection	Power input is reverse polarity protected	
	USB Supply	5VDC (via USB programming port)	
Communication Port & Terminal Block Replacement		AutomationDirect p/n C0-3TB	
24VDC Power Terminal Block Replacement		AutomationDirect p/n C0-4TB	
Antenna Requirements		2.4 GHz antenna, RP-SMA connector (AutomationDirect p/n SE-ANT250 or SE-ANT210)	
Weight		4.0 oz [114g]	4.6 oz [129g]

* Power consumption shown is the maximum power consumption with the maximum number of I/O modules attached.

PLC Unit Specifications, continued

USB Programming Port Specifications	
Communications Ratings	USB 2.0 Full Speed (12Mbps)
Connector	Micro USB Type B
Bus Power	Yes, Max 500mA 5VDC USB Bus power supplied under the following conditions: <ul style="list-style-type: none"> • Firmware update and Project update • Stop WLAN and Bluetooth function • Stop access the modules on Stackable I/O bus • PLC in Stop Mode
Recommended Cable	AutomationDirect p/n USB-CBL-AMICB6
USB Cable Length	Max 15ft.

USB Port Pin Descriptions		
1	VBUS	5V Power supply in
2	D-	Differential signal -
3	D+	Differential signal +
4	NC	Not connected (ID not used)
5	GND	Ground



Ethernet Port Specifications	
Communications Ratings	10/100 Base-T
Cable Specifications	Category 5
Auto MDI/MDIX	Yes
Connector	RJ45
Default Settings	IP Address assigned by DHCP Fallback on DHCP Failure: <ul style="list-style-type: none"> • IP Address: 169.254.x.x (APIPA) • Subnet Mask: 255.255.0.0 • Default Gateway: 0.0.0.0

Ethernet Port Pin Descriptions		
1	TD+	Transmit Data (+)
2	TD-	Transmit Data (-)
3	RD+	Receive Data (+)
4	-	Not connected
5	-	Not connected
6	RD-	Receive Data (-)
7	-	Not connected
8	-	Not connected

8 pin RJ45 Phone Type Jack

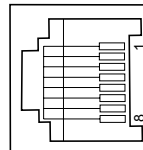

PLC Unit Specifications, continued

Micro SD Card Slot Specifications	
Card Type	microSDHC
Format	FAT32
Capacity	4GB to 32GB



NOTE: An SD card with SLC mode, such as AutomationDirect #[MSD-SLC16G](#), is strongly recommended for increased maximum lifetime write cycles.

SD Card Pin Descriptions	
1	DAT2
2	CD/DAT3
3	CMD
4	VDD
5	CLK
6	VSS
7	DAT0
8	DAT1

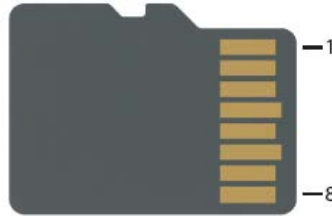

Wireless LAN (WLAN) Specifications		
Standard	IEEE 802.11/b/g/n	
Frequency	2.4 GHz	
Maximum Transmitting Power	20.5 dBm	
Transmission Distance	Up to 30m	
Line Speed	Up to 150 Mbps	
WLAN Mode	Station	
Security	v3.00-v3.40: WEP, WPA, WPA2	v3.42+: WPA2, WPA3
Encryption	v3.00-v3.40: AES128	v3.42+: AES128, AES192
Antenna	External (50Ω RP-SMA Jack/Female Port)	
RF Certification	FCC/CE(Red)/IC/MIC/RCM	
Status Lamp	WLAN(Green)	

Bluetooth Specifications	
Standard	IEEE 802.15.1 v4.2 Bluetooth Low Energy
Frequency	2.4 GHz
Maximum Transmitting Power	13.4 dBm (EIRP)
Transmission Distance	Up to 10m
Line Speed	Up to 260 kbps
Antenna	External (50Ω RP-SMA Jack/Female Port)
Association Certification	Bluetooth SIG
Pairing	Yes
RF Certification	FCC/CE(Red)/IC/MIC/RCM
Status Lamp	BT (Blue)

PLC Unit Specifications, continued

RS-232 Port Specifications	
Communications Ratings	Conforms to RS-232
Communications Parameters	<ul style="list-style-type: none"> • Baud rate: 2400, 4800, 9600, 19200, 38400, 57600, 115.2k bps • Data bit: 7 bits, 8 bits • Parity: None, Odd, Even • Stop bit: 1 bit, 2 bits
Connector	RJ12 Phone Jack
Recommended Cable	AutomationDirect p/n USB-CBL-AMICB6
Power Supply to HMI (Output) (EA1 or EA3 series)	Supply 5V, 200mA

RS-232 Port Pin Descriptions		
1	GND	Ground
2	5V out	5V output, 200mA
3	RXD	Receive Data (RS-232)
4	TXD	Transmit Data (RS-232)
5	RTS	Request to Send (RS-232)
6	GND	Ground

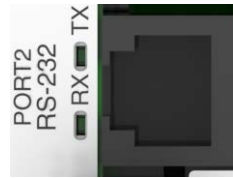

RS-485 Port Specifications	
Communications Ratings	Conforms to RS-485
Communications Parameters	<ul style="list-style-type: none"> • Baud rate: 2400, 4800, 9600, 19200, 38400, 57600, 115.2k bps • Data bit: 7 bits, 8 bits • Parity: None, Odd, Even • Stop bit: 1 bit, 2 bits
Connector	3-wire terminal block
Terminal Type	Removable connector (Phoenix Contact MC1.5 / 3-ST-3.5GY)
Wire Size Range	16–28 AWG
Wire Specification	Supported temperature: > 60°C Material: Copper
Screw Torque	Minimum 1.95 lb-inch [0.22 N·m]
Screwdriver Size	DN-SS1 or compatible (insulated slotted screwdriver 0.4 x 2.5 x 75 mm)
Recommended Cable	Shielded cable (example FUJI ELECTRIC WIRE FKEV-SB-0.3-2P-**)
Recommended Ferrite Core	E04SR401938 (SEIWA)

RS-485 Port Pin Descriptions		
1	+	Differential Signal (+)
2	-	Differential Signal (-)
3	LG	Logic Ground

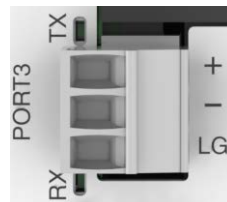

PLC Unit Specifications, continued

Power Terminal Wiring Specifications	
Terminal Type	3.5 mm pitch pluggable terminal block
Wire Range	16-28 AWG
Wire Strip Length	7.0 mm
Wire Specification	Supported temperature: > 60°C Material: Copper
Screw Torque	2.0-2.2 lb-inch [0.22-0.25 N·m]
Screw Size	M2
Number of Pins	4-pin terminal block
Screwdriver Size	DN-SS1 or compatible (insulated slotted screwdriver 0.4 x 2.5 x 75 mm)

Note: C0-00AC or C0-01AC Power Supply recommended.

Power Terminal Pinout	
24V	24V Power supply in
0V	0V Power supply reference
PF	unused
G	Ground



NOTE: DO NOT USE the PF connector. Leave this terminal unconnected. Connecting the PF terminal to another device may cause damage to the CLICK PLUS CPU.

PLC LED Status Indicators

Each CPU includes several LED Status Indicators on the front panel as described in the following illustrations.

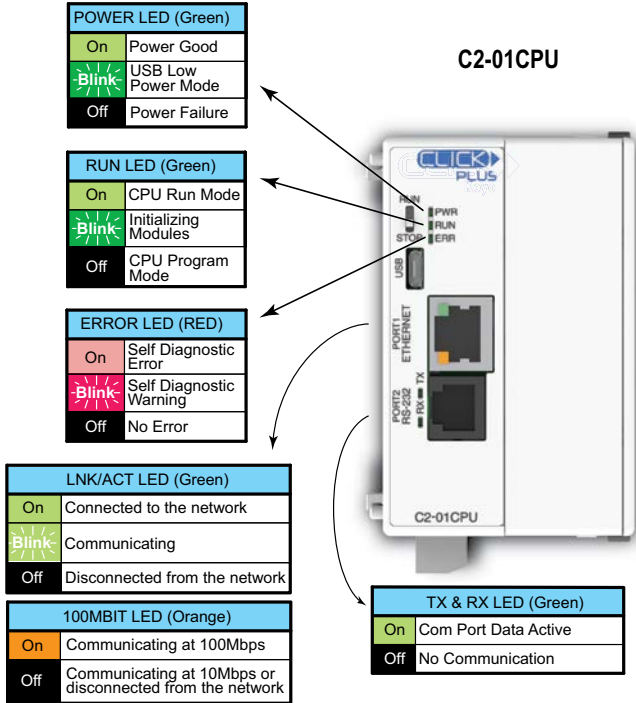

PLC LED Status Indicators, (cont'd)

WLAN LED (Green)	
On	Link
Blink	Activity
Off	No Link

POWER LED (Green)	
On	Power Good
Blink	USB Low Power Mode
Off	Power Failure

RUN LED (Green)	
On	CPU Run Mode
Blink	Initializing Modules
Off	CPU Program Mode

ERROR LED (RED)	
On	Self Diagnostic Error
Blink	Self Diagnostic Warning
Off	No Error

BLUETOOTH LED (Blue)	
On	Link
Blink	Activity (per packet)
Blink	Pairing Mode (500ms flash)
Blink	Disabled in PLC* (200ms flash)
Off	No Link

*Error - Bluetooth disabled in PLC (SC60) is On. Pairing mode disabled.

C2-02CPU

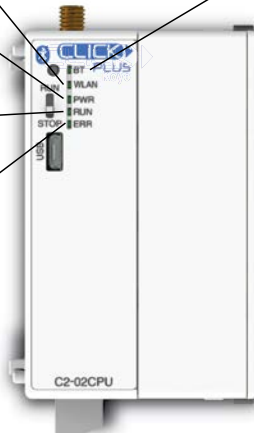

WLAN LED (Green)	
On	Link
Blink	Activity
Off	No Link

POWER LED (Green)	
On	Power Good
Blink	USB Low Power Mode
Off	Power Failure

RUN LED (Green)	
On	CPU Run Mode
Blink	Initializing Modules
Off	CPU Program Mode

ERROR LED (RED)	
On	Self Diagnostic Error
Blink	Self Diagnostic Warning
Off	No Error

LNK/ACT LED (Green)	
On	Connected to the network
Blink	Communicating
Off	Disconnected from the network

100MBIT LED (Orange)	
On	Communicating at 100Mbps
Off	Communicating at 10Mbps or disconnected from the network

C2-03CPU

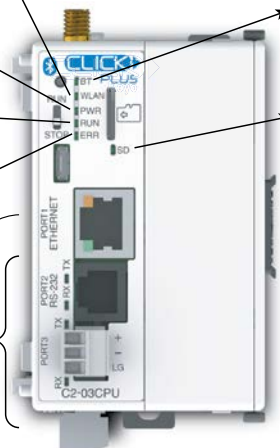

BLUETOOTH LED (Blue)	
On	Link
Blink	Activity (per packet)
Blink	Pairing Mode (500ms flash)
Blink	Disabled in PLC* (200ms flash)
Off	No Link











*Error - Bluetooth disabled in PLC (SC60) is On. Pairing mode disabled.

MICRO SD LED (Green)	
On	Mounted
Blink	Access
Off	No SD Mounted

TX & RX LED (Green)	
On	Com Port Data Active
Off	No Communication

Memory Map

All of the CLICK PLC units support the same memory map. The CLICK PLC uses decimal numbers for the memory addressing. See page 2-134 for the definitions of each data type and memory type.

Memory Type	Symbol	Data Type	S/W Icon	Range
Input Point	X	Bit		X001 – X816
Output Point	Y			Y001 – Y816
Control Relay	C			C1 – C2000
Timer	T			T1 – T500
Counter	CT			CT1 – CT250
System Control Bit	SC			SC1 – SC1000
Data Register	DS	Integer		DS1 – DS4500
	DD	Integer2		DD1 – DD1000
	DH	HEX		DH1 – DH500
	DF	Floating Point		DF1 – DF500
Input Register	XD	HEX		XD0 – XD8
Output Register	YD			YD0 – YD8
Timer Register	TD	Integer		TD1 – TD500
Counter Register	CTD	Integer2		CTD1 – CTD250
System Data Register	SD	Integer		SD1 – SD1000
Text	TXT	Text		TXT1 – TXT1000

CLICK Programming Software PID Specifications

PID Specifications	
PID maximum number of loops	8
Required Memory	40 C bits, 15 DS registers, 25 DF registers
Control Algorithm	Position
Control Loop Action	Direct-acting or Reverse-acting
Error Term	Linear or Squared
Error Dead band	Configurable
Proportional Gain	0.01–10000
Reset Time (Integral)	0.01–6000
Derivative Gain	0.0–6000
Sampling rate	100ms to 30000ms
Loop Calculation	PID or PI
PV Filter	Configurable
Set Point	Maximum and minimum values can be set
Control Output	Maximum and minimum values can be set
Derivative Gain Limit	Configurable
Bias Freeze (Anti-Windup)	Yes
Bumpless Transfer	2 Modes
Pulse Width Modulation (PWM) Output	Yes, up to 600 second period
Auto Tuning	Ziegler-Nichols Limit Cycle
Alarms	
PV Alarm	PV alarm value can be set at Low-low, Low, High, High-high condition
Deviation Alarm	Specify alarms for two ranges of PV deviation from the setpoint value
PV Rate of Change	Detect when PV exceeds a rate of change limit you specify

CLICK PLUS PLC Hardware/Software Compatibility

CLICK programming software version 3.00 or higher is required to utilize the CLICK PLUS CPUs and Option Slot I/O modules.

CLICK programming software version 3.20 or higher is required to utilize the CLICK PLUS 2-slot CPUs and Option Slot Intelligent module C2-DCM.

CLICK programming software version 3.70 or higher is required to utilize the C2-NRED and C2-OPCUA Option Slot Intelligent modules, C2-14TTL Option Slot module and C0-04POT Stackable I/O module.

Option Slot I/O Module Specifications

General Specifications for all CLICK PLUS Option Slot I/O Modules

CLICK PLUS Option Slot Module General Specifications	
Operating Temperature	32°F to 131°F [0°C to 55°C]
Storage Temperature	-4°F to 158°F [-20°C to 70°C] IEC 60068-2-1 (Test Ab, Cold) IEC 60068-2-2 (Test Bb, Dry Heat) IEC 60068-2-14 (Test Na, Thermal Shock)
Ambient Humidity	30% to 95% relative humidity (non-condensing)
Altitude	Up to 2,000m
Environmental Air	No corrosive gases The level for the environmental pollution is 2 (UL840)
Environment	For Indoor Use Only
Vibration	IEC60068-2-6 (Test Fc) 5-9Hz:3.5mm amplitude, 9-150Hz 1.0G 10 sweep cycles per axis on each of 3 mutually perpendicular axes.
Shock	IEC60068-2-27 (Test Ea) 15G peak, 11ms duration, 3 shocks in each direction per axis, on 3 mutually perpendicular axes.
Noise Immunity	<EN61131-2> EN61000-4-2 (ESD) EN61000-4-3 (RFI) EN61000-4-4 (FTB) EN61000-4-6 (Conducted) EN61000-4-8 (Power frequency magnetic field immunity) <Local Test> Impulse Immunity : 1000V @ 1uS pulse
Emissions	EN55011 Class A (Radiated RF emission)
Agency Approvals	UL61010 (File No. E157382, E316037); CE (EN61131-2); CUL Canadian C22.2
Other	RoHS 2011/65/EU Amendment (EU)2015/863 Bluetooth SIG, SD associate

C2-14D1 – 8 DC Input/6 Sinking DC Output Option Slot I/O Module

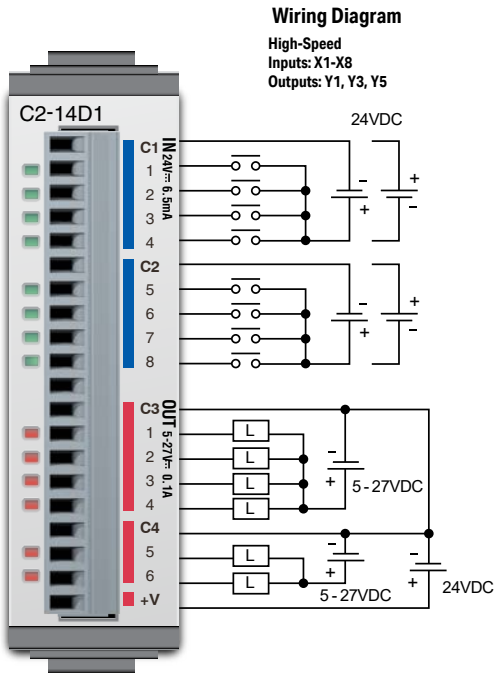

Equivalent Input Circuit

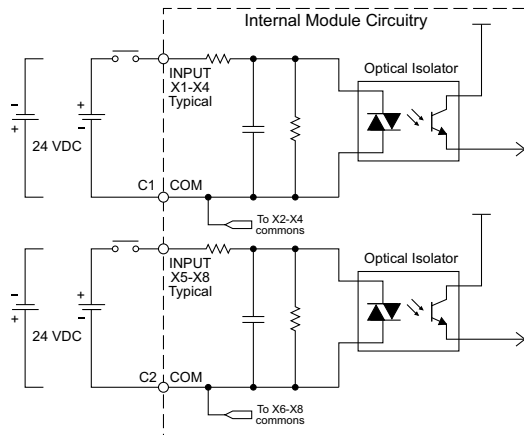

I/O Specifications - Inputs	
Inputs per Module	8 (Sink/Source)
Operating Voltage Range	24VDC
Input Voltage Range	21.6 – 26.4 VDC
Input Current	Typ 6.5 mA @ 24VDC
Maximum Input Current	7.0 mA @ 26.4 VDC
Input Impedance	3.9 kΩ @ 24VDC
Input Frequency (Max)	X1-X8: 100kHz (3m cable)
ON Voltage Level	> 19VDC
OFF Voltage Level	< 2VDC
Minimum ON Current	4.5 mA
Maximum OFF Current	0.5 mA
OFF to ON Response	Typ 3μs Max 5μs
ON to OFF Response	Typ 1μs Max 3μs
Status Indicators	Logic Side (8 points, green LED)
Commons	2 (4 points/common) Isolated

General Specifications	
Current Consumption at 24VDC	50mA max (All Points On)
Terminal Block Replacement Part No.	C0-16TB
Weight	48g

Maximum Number of High Speed Counters	
Up	6
Down	6
Up/Down	3
Pulse/Direction	4
Quadrature A-B	4
Quadrature A-B+Z	2

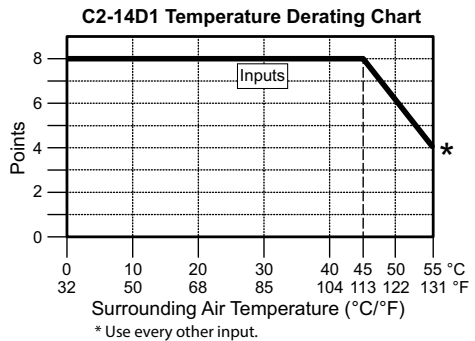

C2-14D1 – 8 DC Input/6 Sinking DC Output Option Slot I/O Module (continued)

I/O Specifications - Outputs	
Outputs per Module	6 (Sink)
Operating Voltage Range	5-27 VDC
Output Voltage Range	4-30 VDC
Maximum Output Current	0.1 A/point; C3: 0.4 A/common, C4: 0.2 A/common
Minimum Output Current	0.2 mA
Maximum Leakage Current	0.1 mA @ 30.0 VDC
On Voltage Drop	0.5 VDC @ 0.1 A
Maximum Inrush Current	150mA for 10ms
Output Frequency (Max)	Y1, Y3, Y5: 100kHz (3m cable)
OFF to ON Response	< 5 μ s (Duty 40-60%, Load current 20mA)
ON to OFF Response	< 5 μ s (Duty 40-60%, Load current 20mA)
Status Indicators	Logic Side (6 points, red LED)
Commons	2 (4 points/com & 2 points/com)
External DC Power Required	20-28 VDC Maximum @ 60mA (All Points On)

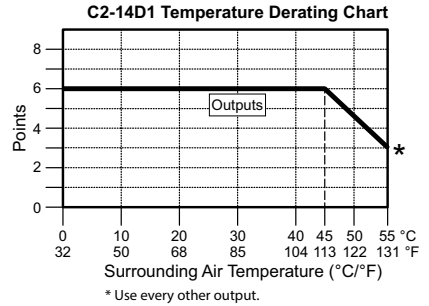

Maximum Number of High Speed Outputs	
Pulse Train	3
Pulse Width Modulation	3

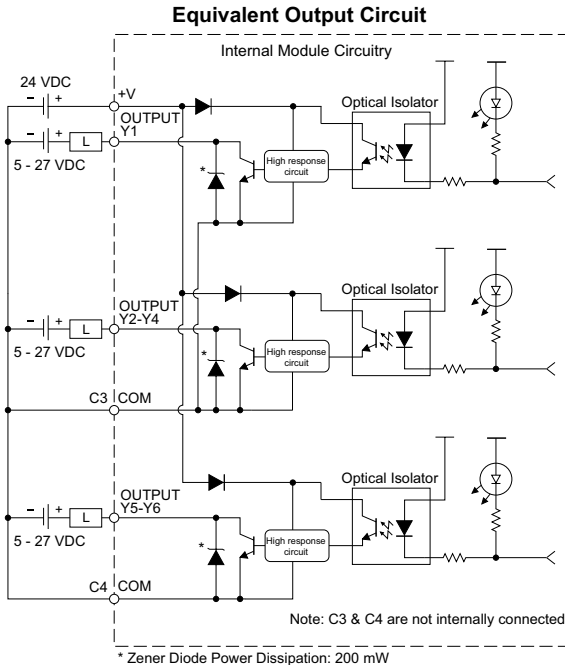

ZIPLink Pre-Wired PLC Connection Cables and Modules for CLICK PLC

- 20-pin connector cable
- ZL-C0-CBL20 (0.5 m length)
- ZL-C0-CBL20-1 (1.0 m length)
- ZL-C0-CBL20-2 (2.0 m length)



ZL-RTB20
20-pin feed-through connector module



C2-14D2 – 8 DC Input/6 Sourcing DC Output Option Slot I/O Module

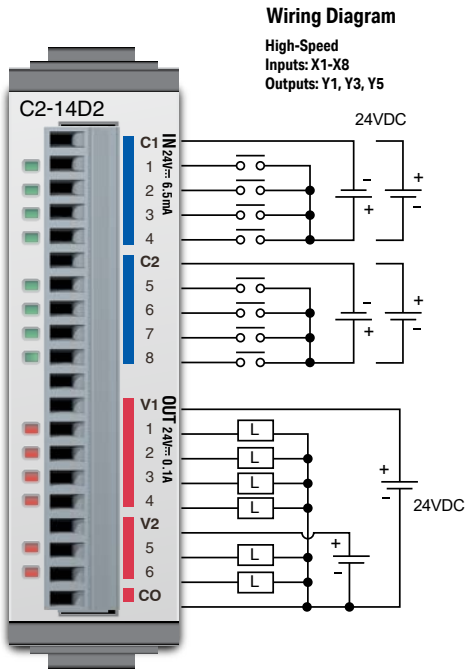

I/O Specifications - Inputs	
Inputs per Module	8 (Sink/Source)
Operating Voltage Range	24VDC
Input Voltage Range	21.6 – 26.4 VDC
Input Current	Typ 6.5 mA @ 24VDC
Maximum Input Current	7.0 mA @ 26.4 VDC
Input Impedance	3.9 kΩ @ 24VDC
Input Frequency (Max)	X1-X8: 100kHz (3m cable)
ON Voltage Level	> 19VDC
OFF Voltage Level	< 2VDC
Minimum ON Current	4.5 mA
Maximum OFF Current	0.5 mA
OFF to ON Response	Typ 3μs Max 5μs
ON to OFF Response	Typ 1μs Max 3μs
Status Indicators	Logic Side (8 points, green LED)
Commons	2 (4 points/common) Isolated

General Specifications	
Current Consumption at 24VDC	50mA max (All Points On)
Terminal Block Replacement Part No.	CO-16TB
Weight	47g

Maximum Number of High Speed Counters	
Up	6
Down	6
Up/Down	3
Pulse/Direction	4
Quadrature A-B	4
Quadrature A-B+Z	2

Equivalent Input Circuit

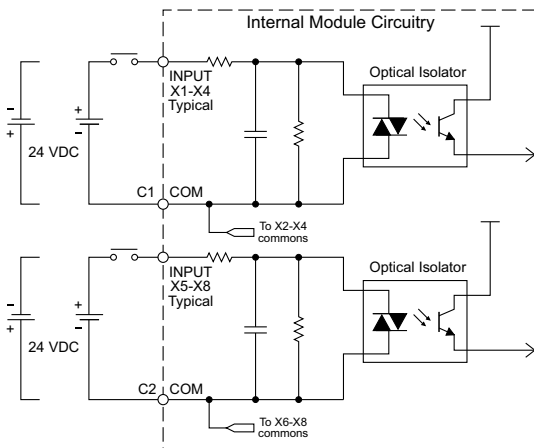

C2-14D2 Temperature Derating Chart

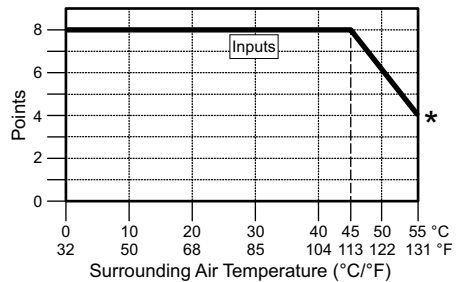

C2-14D2 – 8 DC Input/6 Sourcing DC Output Option Slot I/O Module (continued)

I/O Specifications - Outputs	
Outputs per Module	6 (Source)
Operating Voltage Range	24VDC
Output Voltage Range	19.2-30 VDC
Maximum Output Current	0.1 A/point, 0.6 A/common
Minimum Output Current	0.2 mA
Maximum Leakage Current	0.1 mA @ 30VDC
On Voltage Drop	0.5 VDC @ 0.1 A
Maximum Inrush Current	150mA for 10ms
Output Frequency (Max)	Y1, Y3, Y5: 100kHz (3m cable)
OFF to ON Response	< 5µs (Duty 40-60%, Load current 20mA)
ON to OFF Response	< 5µs (Duty 40-60%, Load current 20mA)
Status Indicators	Logic Side (6 points, red LED)
Commons	1 (6 points/common)

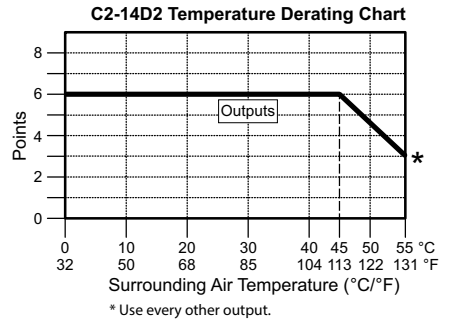

Maximum Number of High Speed Outputs	
Pulse Train	3
Pulse Width Modulation	3

Equivalent Output Circuit

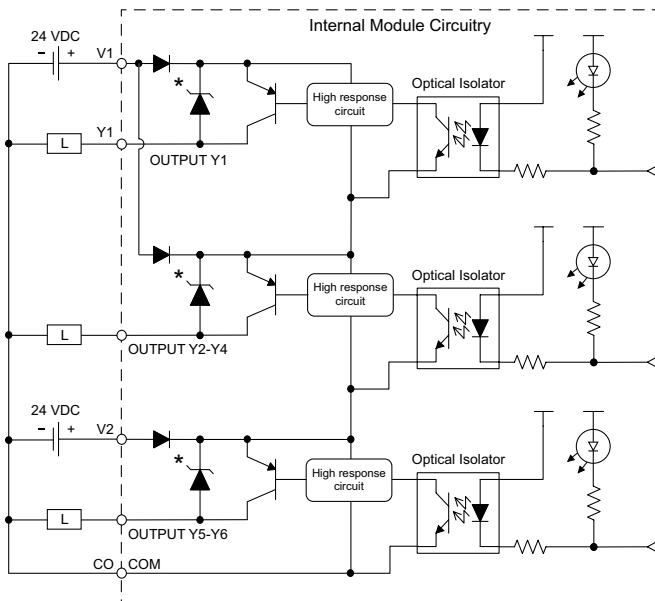

*Zener Diode Power Dissipation: 200 mW

ZIPLink Pre-Wired PLC Connection Cables and Modules for CLICK PLC

- 20-pin connector cable
- ZL-CO-CBL20 (0.5 m length)
- ZL-CO-CBL20-1 (1.0 m length)
- ZL-CO-CBL20-2 (2.0 m length)



- ZL-RTB20
- 20-pin feed-through connector module



C2-14TTL – 8 TTL Input/6 Sourcing TTL Output Option Slot I/O Module

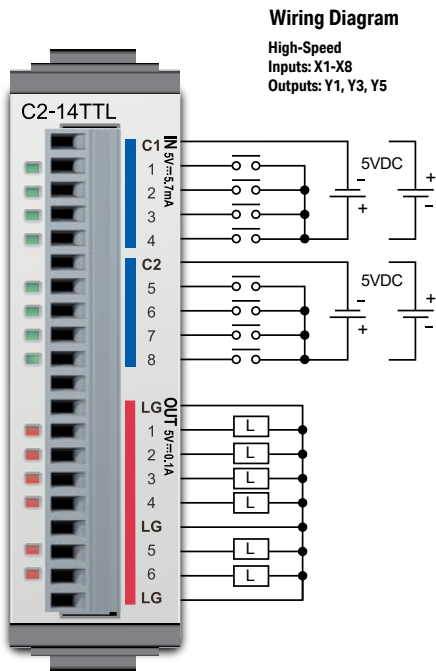

I/O Specifications - Inputs	
Inputs per Module	8 (Sink/Source)
Operating Voltage Range	5VDC
Input Voltage Range	4.5–5.5 VDC
Input Current	Typ 5.7 mA @ 5VDC
Maximum Input Current	7.4 mA @ 5.5 VDC
Input Impedance	360Ω @ 5VDC
Input Frequency (Max)	X1-X8: 100kHz (3m cable)
ON Voltage Level	> 4.0 VDC
OFF Voltage Level	< 2.0 VDC
Minimum ON Current	4.0 mA
Maximum OFF Current	0.5 mA
OFF to ON Response	Typ 3μs Max 5μs
ON to OFF Response	Typ 1μs Max 5μs
Status Indicators	Logic Side (8 points, green LED)
Commons	2 (4 points/common) Isolated

General Specifications	
Current Consumption at 24VDC	220mA max (All Points On)
Terminal Block Replacement Part No.	C0-16TB
Weight	48g

Maximum Number of High Speed Counters	
Up	6
Down	6
Up/Down	3
Pulse/Direction	4
Quadrature A-B	4
Quadrature A-B+Z	2

Equivalent Input Circuit

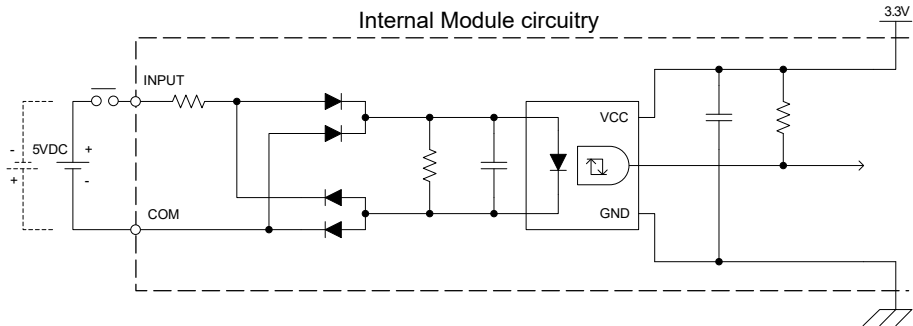

C2-14TTL – 8 TTL Input/6 Sourcing TTL Output Option Slot I/O Module (continued)

I/O Specifications - Outputs	
Outputs per Module	6 (Source)
Operating Voltage Range	5VDC
Output Voltage Range	4.5-5.5 VDC
Maximum Output Current	0.1A/point, 0.6 A/common
Minimum Output Current	0.2 mA
Maximum Leakage Current	0.1 mA @ 5.5 VDC
On Voltage Drop	0.1 VDC @ 0.1 A
Maximum Inrush Current	150mA for 10ms
Output Frequency (Max)	100kHz (3m cable)
OFF to ON Response	< 5µs (Duty 40-60%, Load current 20mA)
ON to OFF Response	< 5µs (Duty 40-60%, Load current 20mA)
Status Indicators	Logic Side (6 points, red LED)
Commons	1 (6 points/common)

Maximum Number of High Speed Outputs	
Pulse Train	3
Pulse Width Modulation	3

Equivalent Output Circuit

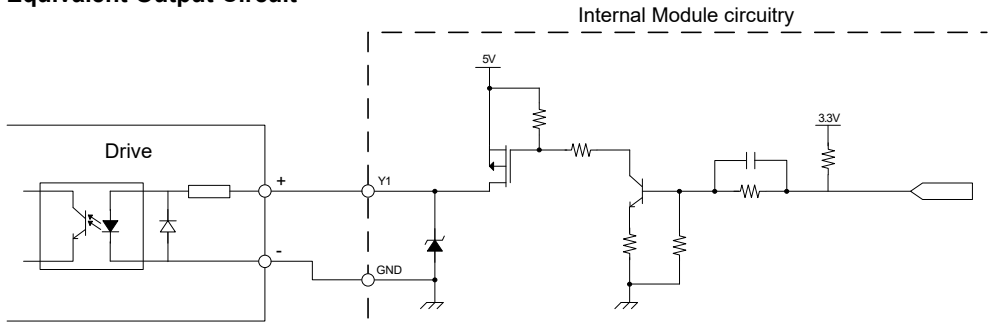

ZIPLink Pre-Wired PLC Connection
Cables and Modules for CLICK PLC

- 20-pin connector cable
- ZL-C0-CBL20 (0.5 m length)
- ZL-C0-CBL20-1 (1.0 m length)
- ZL-C0-CBL20-2 (2.0 m length)



- ZL-RTB20
- 20-pin feed-through connector module



C2-14DR – 8 DC Input/6 Relay Output Option Slot I/O Module

Wiring Diagram

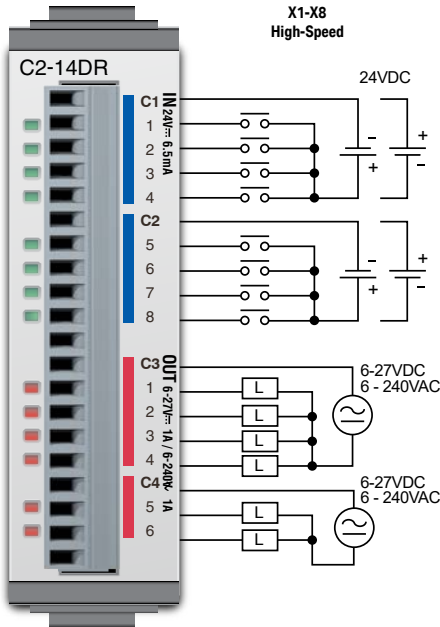

I/O Specifications - Inputs

Inputs per Module	8 (Sink/Source)
Operating Voltage Range	24VDC
Input Voltage Range	21.6 – 26.4 VDC
Input Current	Typ 6.5 mA @ 24VDC
Maximum Input Current	7.0 mA @ 26.4 VDC
Input Impedance	3.9 kΩ @ 24VDC
Input Frequency (Max)	X1-X8: 100kHz (3m cable)
ON Voltage Level	> 19VDC
OFF Voltage Level	< 2VDC
Minimum ON Current	4.5 mA
Maximum OFF Current	0.5 mA
OFF to ON Response	Typ 3μs Max 5μs
ON to OFF Response	Typ 1μs Max 3μs
Status Indicators	Logic Side (8 points, green LED)
Commons	2 (4 points/common) Isolated

General Specifications

Current Consumption at 24VDC	75mA max (All Points On)
Terminal Block Replacement Part No.	C0-16TB
Weight	62g

Equivalent Input Circuit

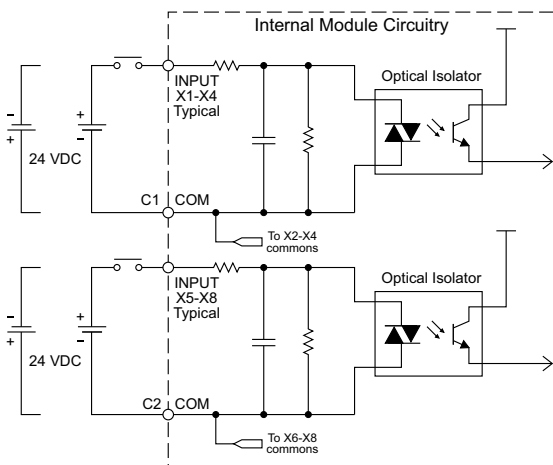

Maximum Number of High Speed Counters

Up	6
Down	6
Up/Down	3
Pulse/Direction	4
Quadrature A-B	4
Quadrature A-B+Z	2

C2-14DR Temperature Derating Chart

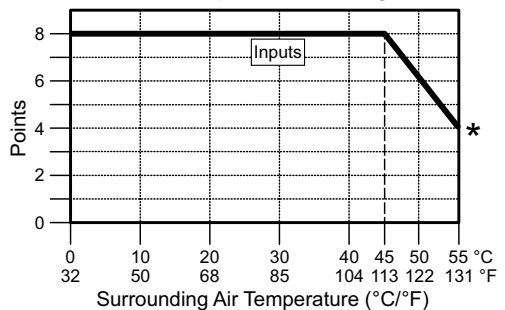

C2-14DR – 8 DC Input/6 Relay Output Option Slot I/O Module (continued)

I/O Specifications - Outputs	
Outputs per Module	6
Operating Voltage Range	6-240 VAC (47-63 Hz), 6-27 VDC
Output Voltage Range	5-264 VAC (47-63 Hz), 5-30 VDC
Output Type	Relay, form A (SPST)
Maximum Current	1A/point; C3: 4A/common, C4: 2A/common
Minimum Load Current	5mA @ 5VDC
Maximum Inrush Current	3A for 10ms
OFF to ON Response	< 15ms
ON to OFF Response	< 15ms
Status Indicators	Logic Side (6 points, red LED)
Commons	2 (4 points/com & 2 points/com) Isolated

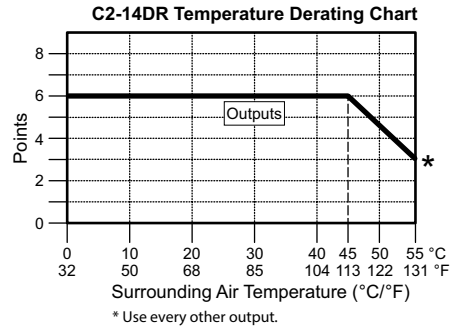

Typical Relay Life (Operations) at Room Temperature	
Voltage & Load Type	Relay Life
30VDC, 1A Resistive	200,000 cycles
30VDC, 1A Inductive	100,000 cycles
250VAC, 1A Resistive	200,000 cycles
250VAC, 1A Inductive	50,000 cycles
ON to OFF = 1 cycle	

Equivalent Output Circuit

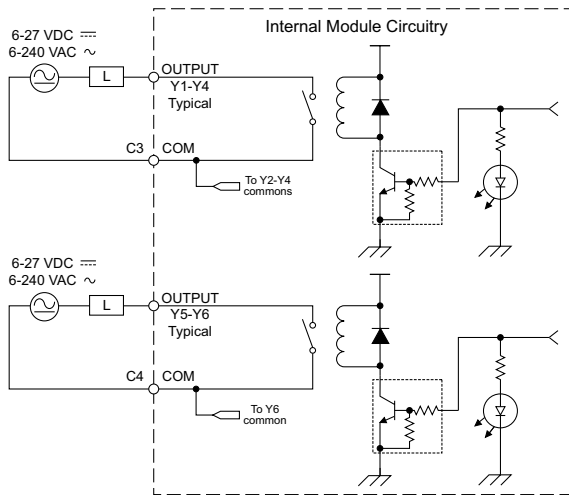

ZIPLink Pre-Wired PLC Connection Cables and Modules for CLICK PLC

- 20-pin connector cable
- ZL-C0-CBL20 (0.5 m length)
- ZL-C0-CBL20-1 (1.0 m length)
- ZL-C0-CBL20-2 (2.0 m length)



- ZL-RTB20
- 20-pin feed-through connector module



NOTE: The C2-14DR is derated to 2A maximum per Common when used with the ZIPLink wiring system.

Insulation Requirements for IEC/UL 61010-1 and 61010-2-201 (sections 6.5 and 6.7)

Input to Output Insulation

Basic insulation is provided between Relay Output 1 and the closest Input terminal. When connecting the Relay Output to a circuit that exceeds 100VAC (141VDC) more than the closest input circuit an additional basic insulation layer must be added to the input circuit.

Output to Output Insulation

Basic insulation is provided between Relay Outputs. When connecting a Relay Output to a circuit that exceeds 100VAC (141VDC) more than the adjacent Relay Outputs, an additional basic insulation layer must be added to the adjacent Relay Output circuits.

Additional Basic Insulation Examples

- Supplementary Insulation: Interposing relay, additional insulating material,... (sec. 6.5.3)
- Automatic Disconnection of the Supply: Properly sized breaker (sec. 6.5.5)
- Current or Voltage Limiting device: Properly sized fuse (sec. 6.5.6)

Basic insulation requires a clearance distance of 1.5 mm or more, a creepage distance of 2.5 mm or more, and dielectric voltage withstand of 1500Vrms.

DC input1 (X1-X4)	Internal circuit
DC input2 (X5-X8)	
Relay output1 (Y1-Y4)	
Relay output2 (Y5-Y6)	

————— : No insulation

----- : Basic insulation

————— : Reinforced insulation

C2-14AR – 8 AC Input/6 Relay Output Option Slot I/O Module

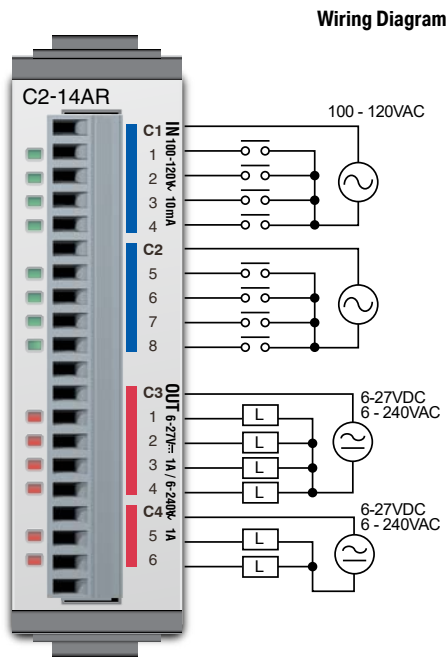

I/O Specifications - Inputs	
Inputs per Module	8
Operating Voltage Range	100-120 VAC
Input Voltage Range	80-144 VAC
AC Frequency	47-63 Hz
Input Current	8.5 mA @ 100VAC at 50Hz 10mA @ 100VAC at 60Hz
Maximum Input Current	16mA @ 144VAC
Input Impedance	15kΩ @ 50Hz 12kΩ @ 60Hz
ON Voltage Level	> 60VAC
OFF Voltage Level	< 20VAC
Minimum ON Current	5mA
Maximum OFF Current	2mA
OFF to ON Response	< 40ms
ON to OFF Response	< 40ms
Status Indicators	Logic Side (8 points, green LED)
Commons	2 (4 points/common) Isolated

General Specifications	
Current Consumption at 24VDC	75mA max (All Points On)
Terminal Block Replacement Part No.	C0-16TB
Weight	63g

Equivalent Input Circuit

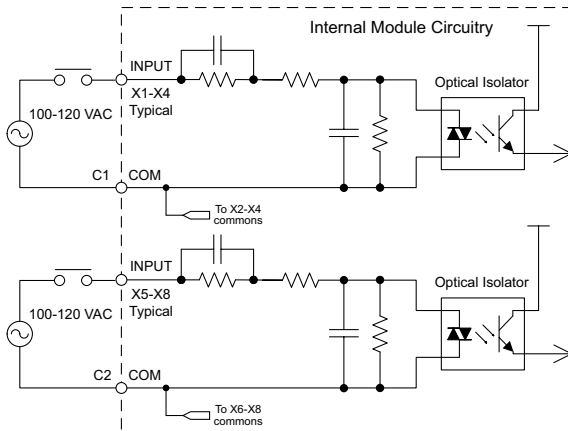

C2-14AR Temperature Derating Chart

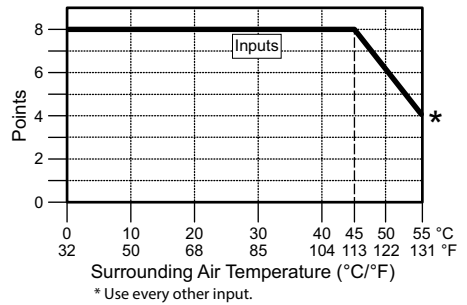

C2-14AR – 8 AC Input/6 Relay Output Option Slot I/O Module (continued)

I/O Specifications - Outputs	
Outputs per Module	6
Operating Voltage Range	6–240 VAC (47–63 Hz), 6–27 VDC
Output Voltage Range	5–264 VAC (47–63 Hz), 5–30 VDC
Output Type	Relay, form A (SPST)
Maximum Current	1A/point; C3: 4A/common, C4: 2A/common
Minimum Load Current	5mA @ 5VDC
Maximum Inrush Current	3A for 10ms
OFF to ON Response	< 15ms
ON to OFF Response	< 15ms
Status Indicators	Logic Side (6 points, red LED)
Commons	2 (4 points/com & 2 points/com) Isolated

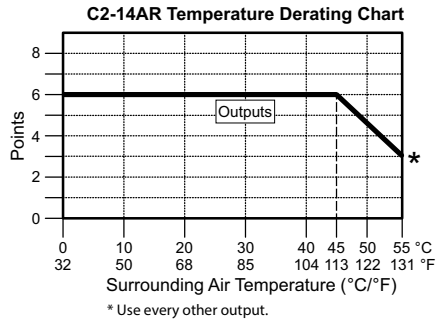

Typical Relay Life (Operations) at Room Temperature	
Voltage & Load Type	Relay Life
30VDC, 1A Resistive	200,000 cycles
30VDC, 1A Inductive	100,000 cycles
250VAC, 1A Resistive	200,000 cycles
250VAC, 1A Inductive	50,000 cycles
ON to OFF = 1 cycle	

Equivalent Output Circuit

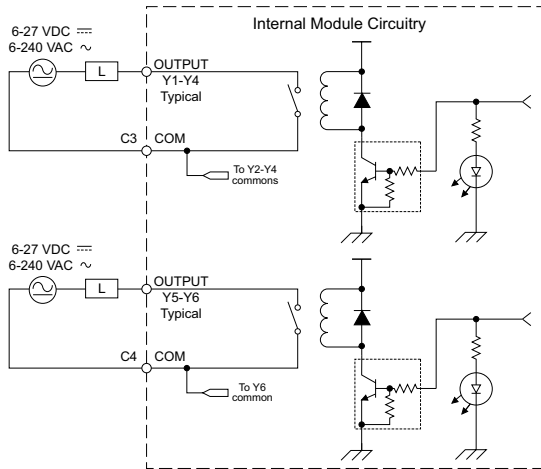

ZIPLink Pre-Wired PLC Connection Cables and Modules for CLICK PLC

- 20-pin connector cable
- ZL-C0-CBL20 (0.5 m length)
- ZL-C0-CBL20-1 (1.0 m length)
- ZL-C0-CBL20-2 (2.0 m length)



ZL-RTB20
20-pin feed-through connector module



NOTE: The C2-14AR is derated to 2A maximum per Common when used with the ZIPLink wiring system.

C2-14AR – 8 AC Input/6 Relay Output Option Slot I/O Module (continued)

Insulation Requirements for IEC/UL 61010-1 and 61010-2-201 (sections 6.5 and 6.7)

Input to Output Insulation

Basic insulation is provided between Relay Output 1 and the closest Input terminal. When connecting the Relay Output to a circuit that exceeds 100VAC (141VDC) more than the closest input circuit an additional basic insulation layer must be added to the input circuit.

Output to Output Insulation

Basic insulation is provided between Relay Outputs. When connecting a Relay Output to a circuit that exceeds 100VAC (141VDC) more than the adjacent Relay Outputs, an additional basic insulation layer must be added to the adjacent Relay Output circuits.

Additional Basic Insulation Examples

- Supplementary Insulation: Interposing relay, additional insulating material,... (sec. 6.5.3)
- Automatic Disconnection of the Supply: Properly sized breaker (sec. 6.5.5)
- Current or Voltage Limiting device: Properly sized fuse (sec. 6.5.6)

Basic insulation requires a clearance distance of 1.5 mm or more, a creepage distance of 2.5 mm or more, and dielectric voltage withstand of 1500Vrms.

AC input1 (X1-X4)	Internal circuit
AC input2 (X5-X8)	
Relay output1 (Y1-Y4)	
Relay output2 (Y5-Y6)	

————— : No insulation

----- : Basic insulation

————— : Reinforced insulation

C2-08D1-4VC – 4 DC Input (Sink/Source)/4 Sinking DC Output

2 Analog Voltage/Current Input

2 Analog Voltage/Current Output Option Slot I/O Module

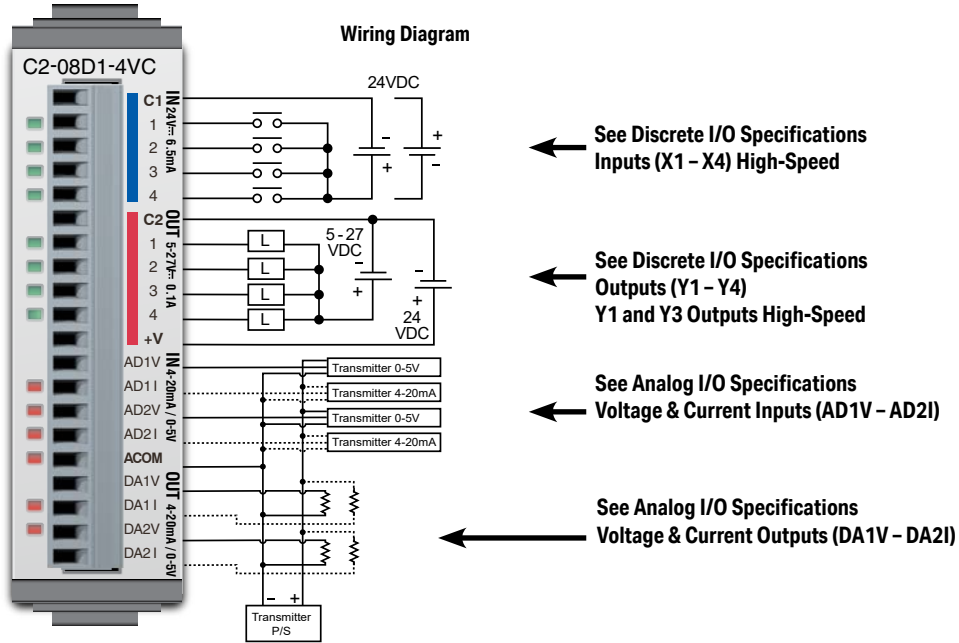

General Specifications	
Current Consumption at 24VDC	80mA max (All Points On)
Terminal Block Replacement Part No.	C0-16TB
Weight	48g

NOTE: Please refer to the Analog I/O Configuration section in Chapter 3 for information on using the analog I/O.

NOTE: There are no ZIPLink pre-wired PLC connection cables and modules for the Analog Option Slot Modules (cannot mix discrete I/O and analog I/O signals in a ZIPLink cable).



C2-08D1-4VC (continued)

X1 - X4

Discrete I/O Specifications - Inputs	
Inputs per Module	4 (Sink/Source)
Operating Voltage Range	24VDC
Input Voltage Range	21.6 - 26.4 VDC
Input Current	Typ 6.5 mA @ 24VDC
Maximum Input Current	7.0 mA @ 26.4 VDC
Input Impedance	3.9 kΩ @ 24VDC
Input Frequency (Max)	X1-X4: 100kHz (3m cable)
ON Voltage Level	> 19VDC
OFF Voltage Level	< 2VDC
Minimum ON Current	4.5 mA
Maximum OFF Current	0.5 mA
OFF to ON Response	Typ 3μs Max 5μs
ON to OFF Response	Typ 1μs Max 3μs
Status Indicators	Logic Side (4 points, green LED)
Commons	1 (4 points/common)

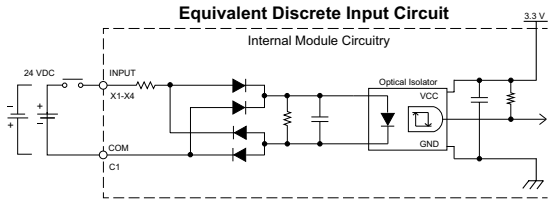

C2-08D1-4VC Temperature Derating Chart

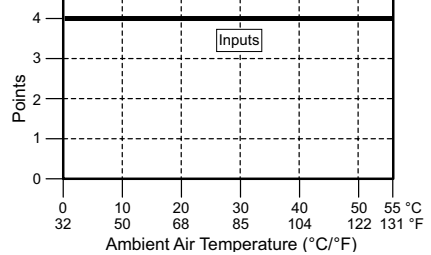

Maximum Number of High Speed Counters	
Up	4
Down	4
Up/Down	2
Pulse/Direction	2
Quadrature A-B	2
Quadrature A-B+Z	1

Y1 - Y4

Discrete I/O Specifications - Outputs	
Outputs per Module	4 (Sink)
Operating Voltage Range	5-27 VDC
Maximum Output Current	0.1 A/point; 0.4 A/common
Minimum Output Current	0.2 mA
Maximum Leakage Current	0.1 mA @ 30.0 VDC
On Voltage Drop	0.5 VDC @ 0.1 A
Maximum Inrush Current	150mA for 10ms
Output Frequency (Max)	Y1, Y3: 100kHz (3m cable)
OFF to ON Response	< 5μs (Duty 40-60%, Load current 20mA)
ON to OFF Response	< 5μs (Duty 40-60%, Load current 20mA)
Status Indicators	Logic Side (4 points, red LED)
Commons	1 (4 points/common)
External DC Power Required	20-28 VDC Maximum @ 60mA (All points ON)

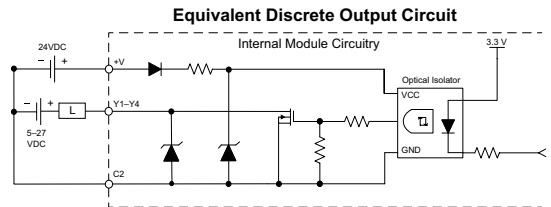

C2-08D1-4VC Temperature Derating Chart

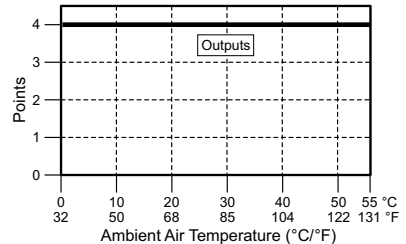

Maximum Number of High Speed Outputs	
Pulse Train	2
Pulse Width Modulation	2

C2-08D1-4VC (continued)

AD1V - AD2I

Analog Specifications - Voltage Input	
Inputs per Module	2 (voltage/current selectable)
Input Range	0-5 VDC (6VDC Max.)
Resolution	12-bit
Conversion Time	50ms
Input Impedance	20kΩ
Input Stability	±2 LSB maximum
Full-Scale Calibration Error	±2% maximum
Offset Calibration Error	±25mV maximum
Accuracy vs. Temperature Error	±100ppm/°C maximum

Analog Specifications - Current Input	
Inputs per Module	2 (voltage/current selectable)
Input Range	4-20 mA (sink)
Resolution	12-bit
Conversion Time	50ms
Input Impedance	125Ω
Input Stability	±2 LSB maximum
Full-Scale Calibration Error	±2% maximum
Offset Calibration Error	±0.1 mA maximum
Accuracy vs. Temperature Error	±100ppm/°C maximum

Analog Voltage Input Circuit

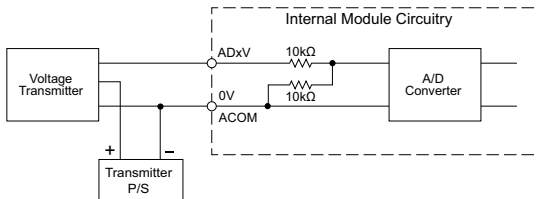

Analog Current Input Circuit

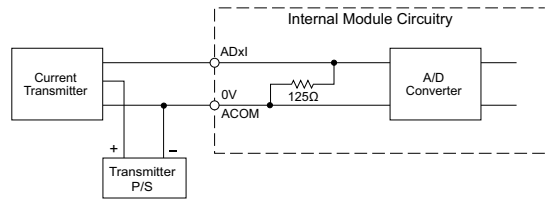

DA1V - DA2I

Analog Specifications - Voltage Output	
Outputs per Module	2 (voltage/current selectable)
Output Range	0-5 VDC
Resolution	12-bit
Conversion Time	1ms
Load Impedance	2kΩ minimum (output current 2.5 mA maximum)
Full-Scale Calibration Error	±2% maximum
Offset Calibration Error	±25mV maximum
Accuracy vs. Temperature Error	±100ppm/°C maximum

Analog Specifications - Current Output	
Outputs per Module	2 (voltage/current selectable)
Output Range	4-20 mA (sink)
Resolution	12-bit
Conversion Time	1ms
Loop Supply Voltage	DC 18-30 V
Load Impedance	250Ω Load Power Supply: DC 18V: 600Ω maximum DC 24V: 900Ω maximum DC 30V: 1200Ω maximum
Full-Scale Calibration Error	±2% maximum
Offset Calibration Error	±25mA maximum
Accuracy vs. Temperature Error	±100ppm/°C maximum

Analog Voltage Output Circuit

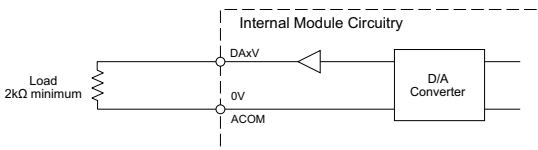

Analog Current Output Circuit

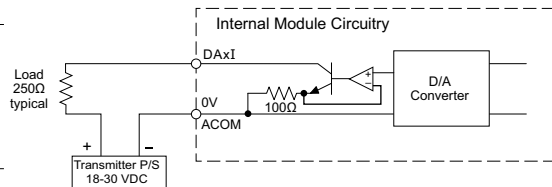

C2-08D2-4VC – 4 DC Input (Sink/Source)/4 Sourcing DC Output

2 Analog Voltage/Current Input

2 Analog Voltage/Current Output Option Slot I/O Module

Wiring Diagram

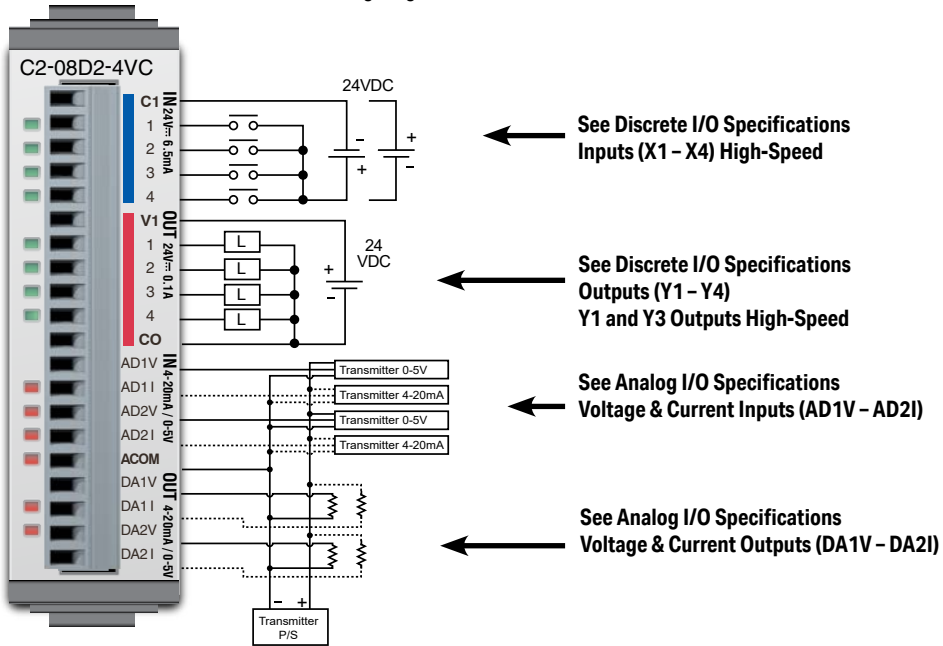

General Specifications	
Current Consumption at 24VDC	80mA max (All Points On)
Terminal Block Replacement Part No.	CO-16TB
Weight	48g

NOTE: Please refer to the Analog I/O Configuration section in Chapter 3 for information on using the analog I/O.



NOTE: There are no ZIPLink pre-wired PLC connection cables and modules for the Analog Option Slot Modules (cannot mix discrete I/O and analog I/O signals in a ZIPLink cable).

Chapter 2: Specifications

C2-08D2-4VC (continued)

X1 - X4

Discrete I/O Specifications - Inputs	
Inputs per Module	4 (Sink/Source)
Operating Voltage Range	24VDC
Input Voltage Range	21.6 - 26.4 VDC
Input Current	Typ 6.5 mA @ 24VDC
Maximum Input Current	7mA @ 26.4 VDC
Input Impedance	3.9 kΩ @ 24VDC
Input Frequency (Max)	X1-X4: 100kHz (3m cable)
ON Voltage Level	> 19VDC
OFF Voltage Level	< 2VDC
Minimum ON Current	4.5 mA
Maximum OFF Current	0.5 mA
OFF to ON Response	Typ 3μs, Max 5μs
ON to OFF Response	Typ 1μs, Max 3μs
Status Indicators	Logic Side (4 points, green LED)
Commons	1 (4 points/common)

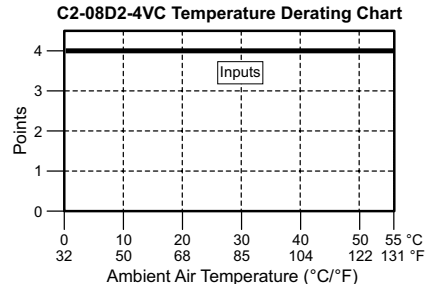
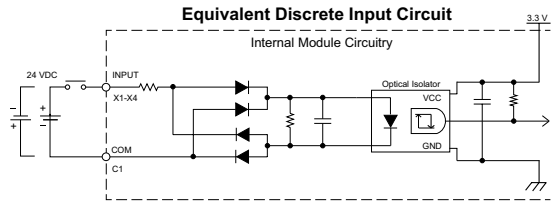

Maximum Number of High Speed Counters	
Up	4
Down	4
Up/Down	2
Pulse/Direction	2
Quadrature A-B	2
Quadrature A-B+Z	1

Y1 - Y4

Discrete I/O Specifications - Outputs	
Outputs per Module	4 (Source)
Operating Voltage Range	24VDC
Output Voltage Range	19.2-30 VDC
Maximum Output Current	0.1 A/point, 0.4 A/common
Minimum Output Current	0.2 mA
Maximum Leakage Current	0.1mA @ 30VDC
On Voltage Drop	0.5 VDC @ 0.1 A
Maximum Inrush Current	150mA for 10ms
Output Frequency (Max)	Y1, Y3: 100kHz (3m cable)
OFF to ON Response	< 5μs (Duty 40-60%, Load current 20mA)
ON to OFF Response	< 5μs (Duty 40-60%, Load current 20mA)
Status Indicators	Logic Side (4 points, red LED)
Commons	1 (4 points/common)

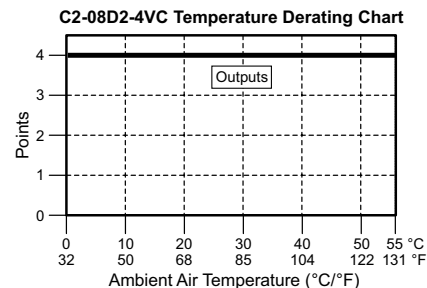
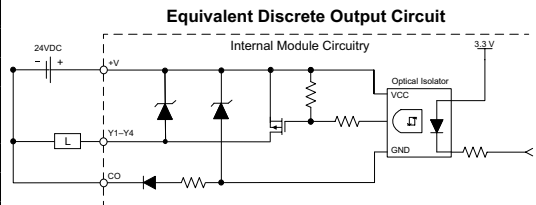

Maximum Number of High Speed Outputs	
Pulse Train	2
Pulse Width Modulation	2

C2-08D2-4VC (continued)

AD1V - AD2I

Analog Specifications - Voltage Input	
Inputs per Module	2 (voltage/current selectable)
Input Range	0-5 VDC
Resolution	12-bit
Conversion Time	50ms
Input Impedance	20k Ω
Input Stability	± 2 LSB maximum
Full-Scale Calibration Error	$\pm 2\%$ maximum
Offset Calibration Error	± 25 mV maximum
Accuracy vs. Temperature Error	± 100 ppm/ $^{\circ}$ C maximum

Analog Voltage Input Circuit

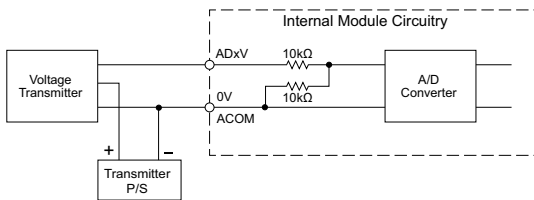

Analog Specifications - Current Input	
Inputs per Module	2 (voltage/current selectable)
Input Range	4-20 mA (sink)
Resolution	12-bit
Conversion Time	50ms
Input Impedance	125 Ω
Input Stability	± 2 LSB maximum
Full-Scale Calibration Error	$\pm 2\%$ maximum
Offset Calibration Error	± 0.1 mA maximum
Accuracy vs. Temperature Error	Less than ± 100 ppm/ $^{\circ}$ C

Analog Current Input Circuit

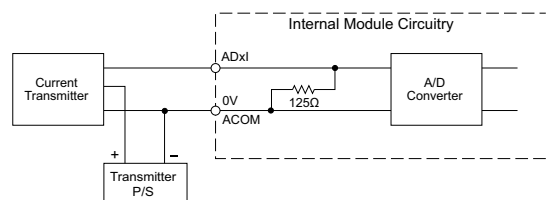

DA1V - DA2I

Analog Specifications - Voltage Output	
Outputs per Module	2 (voltage/current selectable)
Output Range	0-5 VDC
Resolution	12-bit
Conversion Time	1ms
Load Impedance	2k Ω minimum (output current 2.5 mA maximum)
Full-Scale Calibration Error	$\pm 2\%$ maximum
Offset Calibration Error	± 25 mV maximum
Accuracy vs. Temperature Error	± 100 ppm/ $^{\circ}$ C maximum

Analog Voltage Output Circuit

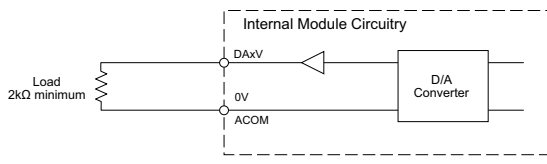

Analog Specifications - Current Output	
Outputs per Module	2 (voltage/current selectable)
Output Range	4-20 mA (sink)
Resolution	12-bit
Conversion Time	1ms
Loop Supply Voltage	DC 18-30 V
Load Impedance	250 Ω Load Power Supply: DC 18V: 600 Ω maximum DC 24V: 900 Ω maximum DC 30V: 1200 Ω maximum
Full-Scale Calibration Error	$\pm 2\%$ maximum
Offset Calibration Error	± 25 mA maximum
Accuracy vs. Temperature Error	± 100 ppm/ $^{\circ}$ C maximum

Analog Current Output Circuit

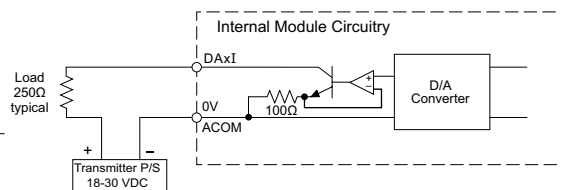

C2-08DR-4VC – 4 DC Input (Sink/Source)/4 Relay Output

2 Analog Voltage/Current Input

2 Analog Voltage/Current Output Option Slot I/O Module

Wiring Diagram

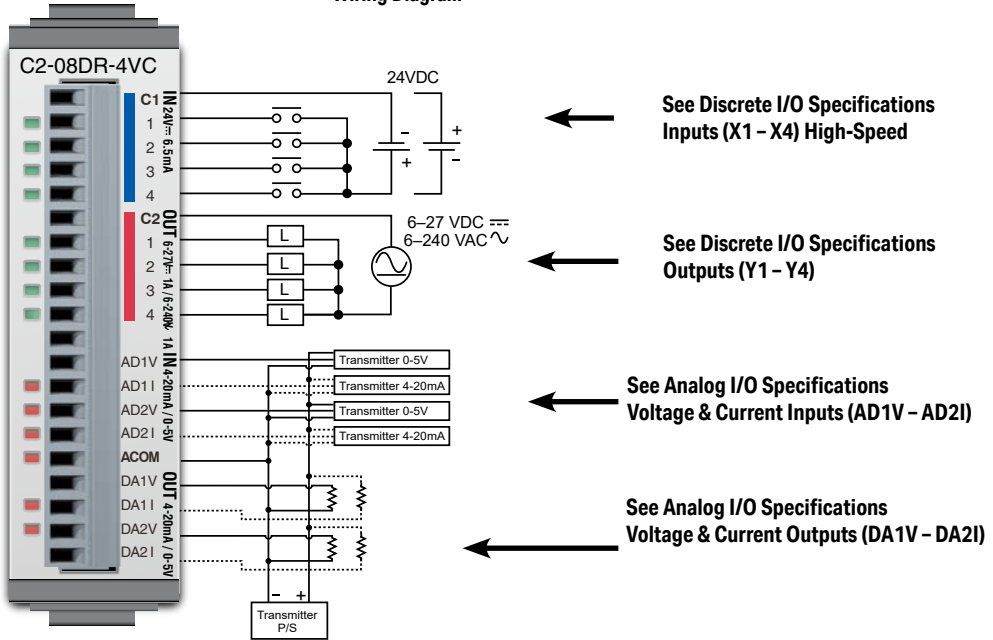

General Specifications	
Current Consumption at 24VDC	100mA max (All Points On)
Terminal Block Replacement Part No.	CO-16TB
Weight	58g

NOTE: Please refer to the Analog I/O Configuration section in Chapter 3 for information on using the analog I/O.



NOTE: There are no ZIPLink pre-wired PLC connection cables and modules for the Analog Option Slot Modules (cannot mix discrete I/O and analog I/O signals in a ZIPLink cable).

C2-08DR-4VC (continued)

X1 - X4

Discrete I/O Specifications - Inputs	
Inputs per Module	4 (Source/Sink)
Operating Voltage Range	24VDC
Input Voltage Range	21.6 – 26.4 VDC
Input Current	Typ 6.5 mA @ 24VDC
Input Impedance	3.9 kΩ @ 24 VDC
Input Frequency (Max)	X1-X4: 100kHz (3m cable)
ON Voltage Level	> 19VDC
OFF Voltage Level	< 2VDC
Minimum ON Current	4.5 mA
Maximum OFF Current	0.5 mA
OFF to ON Response	Typ 3μs, Max 5μs
ON to OFF Response	Typ 1μs, Max 3μs
Status Indicators	Logic Side (4 points, green LED)
Commons	1 (4 points/common)

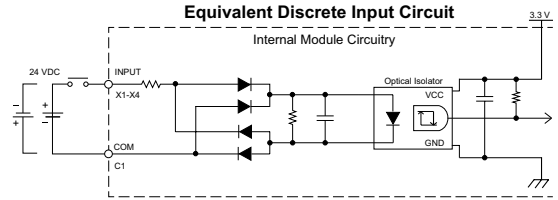

Maximum Number of High Speed Counters	
Up	4
Down	4
Up/Down	2
Pulse/Direction	2
Quadrature A-B	2
Quadrature A-B+Z	1

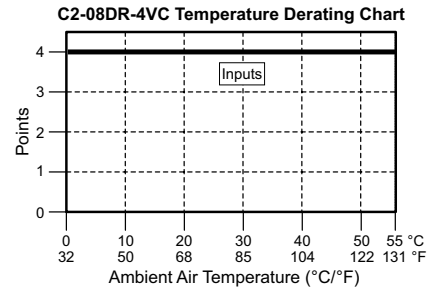

Y1 - Y4

Discrete I/O Specifications - Outputs	
Outputs per Module	4
Operating Voltage Range	6–27 VDC / 6–240 VAC
Output Type	Relay, form A (SPST)
AC Frequency	47–63 Hz
Maximum Current	1A/point (resistive)
Minimum Load Current	5mA @ 5VDC
Maximum Inrush Current	3A for 10ms
OFF to ON Response	< 15ms
ON to OFF Response	< 15ms
Status Indicators	Logic Side (4 points, red LED)
Commons per Module	1 (4 points/common)

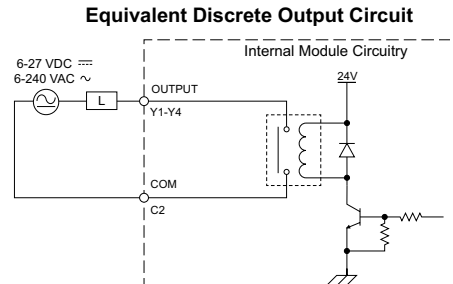

Typical Relay Life (Operations) at Room Temperature	
Voltage & Load Type	Relay Life
30VDC, 1A Resistive	200,000 cycles
30VDC, 1A Inductive	100,000 cycles
250VAC, 1A Resistive	200,000 cycles
250VAC, 1A Inductive	50,000 cycles
ON to OFF = 1 cycle	

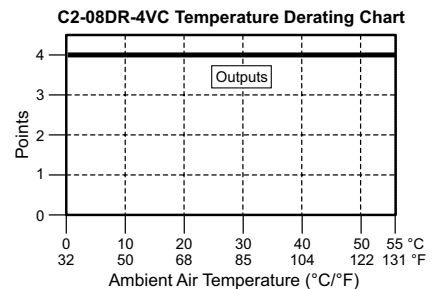

C2-08DR-4VC (continued)

AD1V - AD2I

Analog Specifications - Voltage Input	
Inputs per Module	2 (voltage/current selectable)
Input Range	0-5 VDC (6VDC Max.)
Resolution	12-bit
Conversion Time	50ms
Input Impedance	20kΩ
Input Stability	±2 LSB maximum
Full-Scale Calibration Error	±2% maximum
Offset Calibration Error	±25mV maximum
Accuracy vs. Temperature Error	±100ppm/°C maximum

Analog Specifications - Current Input	
Inputs per Module	2 (voltage/current selectable)
Input Range	4-20 mA (sink)
Resolution	12-bit
Conversion Time	50ms
Input Impedance	125Ω
Input Stability	±2 LSB maximum
Full-Scale Calibration Error	±2% maximum
Offset Calibration Error	±0.1 mA maximum
Accuracy vs. Temperature Error	±100ppm/°C maximum

Analog Voltage Input Circuit

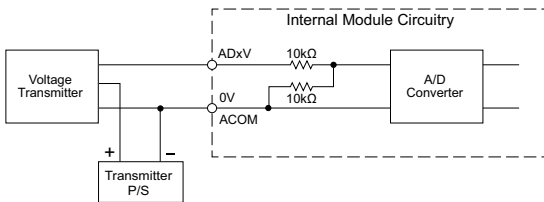

Analog Current Input Circuit

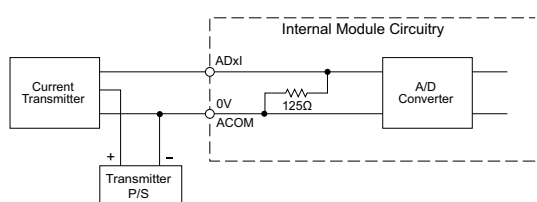

DA1V - DA2I

Analog Specifications - Voltage Output	
Outputs per Module	2 (voltage/current selectable)
Output Range	0-5 VDC
Resolution	12-bit
Conversion Time	1ms
Load Impedance	2kΩ minimum (output current 2.5 mA maximum)
Full-Scale Calibration Error	±2% maximum
Offset Calibration Error	±25mV maximum
Accuracy vs. Temperature Error	±100ppm/°C maximum

Analog Specifications - Current Output	
Outputs per Module	2 (voltage/current selectable)
Output Range	4-20 mA (sink)
Resolution	12-bit
Conversion Time	1ms
Loop Supply Voltage	DC 18-30 V
Load Impedance	250Ω Load Power Supply: DC 18V: 600Ω maximum DC 24V: 900Ω maximum DC 30V: 1200Ω maximum
Full-Scale Calibration Error	±2% maximum
Offset Calibration Error	±25mA maximum
Accuracy vs. Temperature Error	±100ppm/°C maximum

Analog Voltage Output Circuit

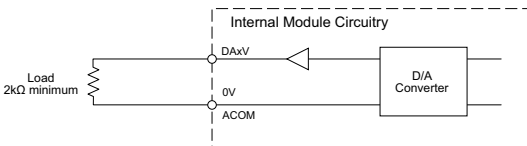

Analog Current Output Circuit

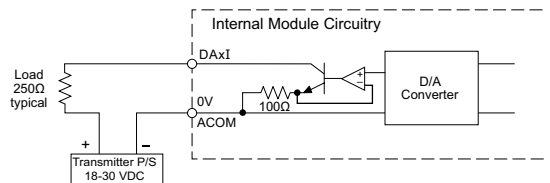

C2-08DR-4VC (continued)

Insulation Requirements for IEC/UL 61010-1 and 61010-2-201 (sections 6.5 and 6.7)**Input to Output Insulation**

Basic insulation is provided between the Relay Output and the closest Input terminal. When connecting the Relay Output to a circuit that exceeds 100VAC (141VDC) more than the closest input circuit an additional basic insulation layer must be added to the input circuit.

Additional Basic Insulation Examples

- Supplementary Insulation: Interposing relay, additional insulating material,... (sec. 6.5.3)
- Automatic Disconnection of the Supply: Properly sized breaker (sec. 6.5.5)
- Current or Voltage Limiting device: Properly sized fuse (sec. 6.5.6)

Basic insulation requires a clearance distance of 1.5 mm or more, a creepage distance of 2.5 mm or more, and dielectric voltage withstand of 1500Vrms.

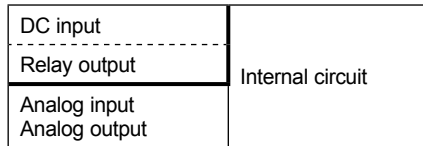

————— : No insulation

----- : Basic insulation

————— : Reinforced insulation

C2-08AR-4VC – 4 AC Input/4 Relay Output

2 Analog Voltage/Current Input

2 Analog Voltage/Current Output Option Slot I/O Module

Wiring Diagram

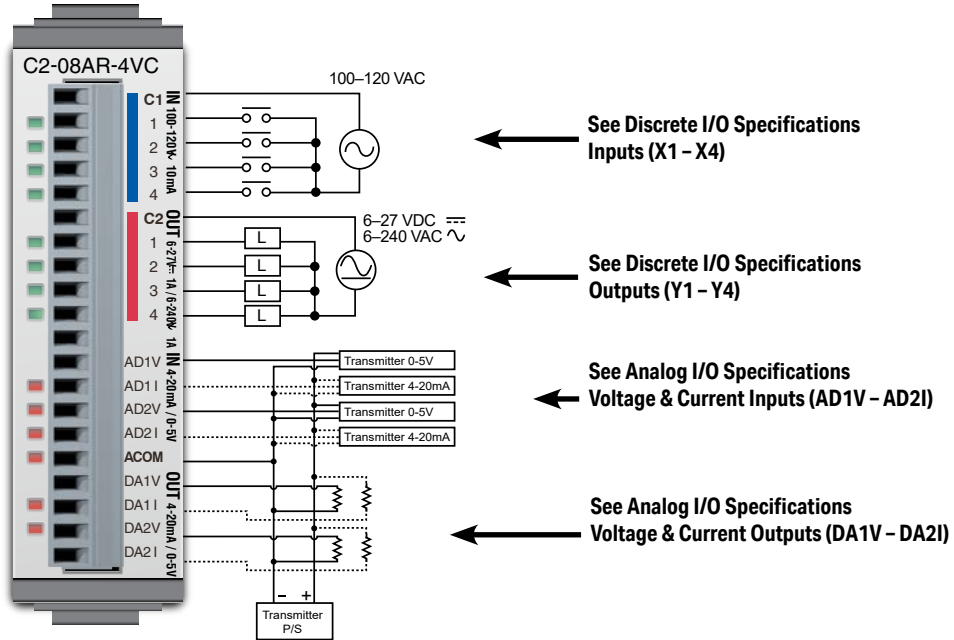

General Specifications	
Current Consumption at 24VDC	100mA max (All Points On)
Terminal Block Replacement Part No.	C0-16TB
Weight	58g

NOTE: Please refer to the Analog I/O Configuration section in Chapter 3 for information on using the analog I/O.



NOTE: There are no ZIPLink pre-wired PLC connection cables and modules for the Analog Option Slot Modules (cannot mix discrete I/O and analog I/O signals in a ZIPLink cable).

C2-08AR-4VC (continued)

X1 - X4

Discrete I/O Specifications - Inputs	
Inputs per Module	4
Operating Voltage Range	100-120 VAC
AC Frequency	47-63 Hz
Input Current	Typ 8.5 mA @ 100VAC (50Hz) Typ 10mA @100VAC (60Hz)
Max. Input Current	16mA @ 144VAC
Input Impedance	15kΩ @ 50Hz 12kΩ @ 60Hz
ON Voltage Level	> 60VAC
OFF Voltage Level	< 20VAC
Minimum ON Current	5mA
Maximum OFF Current	2mA
OFF to ON Response	< 40ms
ON to OFF Response	< 40ms
Status Indicators	Logic Side (4 points, green LED)
Commons	1 (4 points/common)

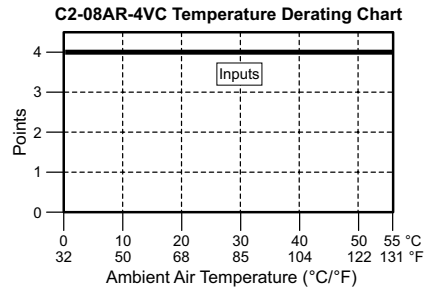
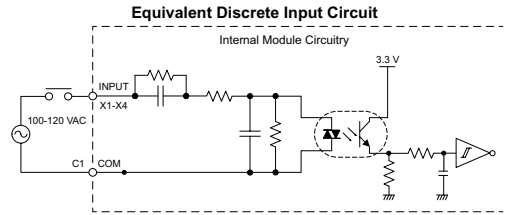

Y1 - Y4

Discrete I/O Specifications - Outputs	
Outputs per Module	4
Operating Voltage Range	6-27 VDC, 6-240 VAC
Output Type	Relay, form A (SPST)
AC Frequency	47-63 Hz
Maximum Current	1A/point (resistive)
Minimum Load Current	5mA @ 5VDC
Maximum Inrush Current	3A for 10ms
OFF to ON Response	< 15ms
ON to OFF Response	< 15ms
Status Indicators	Logic Side (4 points, red LED)
Commons per Module	1 (4 points/common)

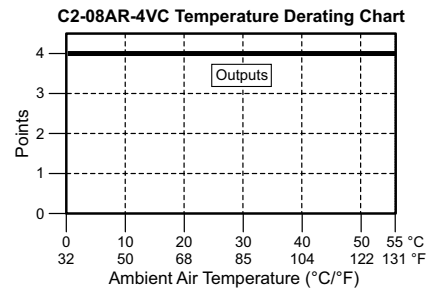
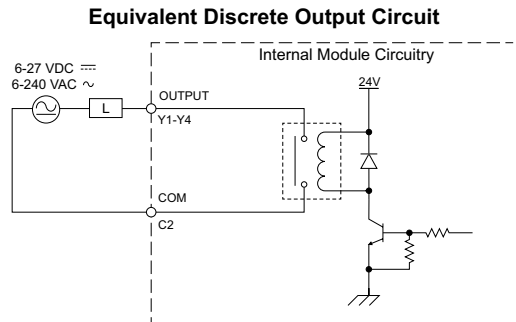

Typical Relay Life (Operations) at Room Temperature	
Voltage & Load Type	Relay Life
30VDC, 1A Resistive	200,000 cycles
30VDC, 1A Inductive	100,000 cycles
250VAC, 1A Resistive	200,000 cycles
250VAC, 1A Inductive	50,000 cycles
ON to OFF = 1 cycle	

C2-08AR-4VC (continued)

AD1V - AD2V

Analog Specifications - Voltage Input	
Inputs per Module	2 (voltage/current selectable)
Input Range	0-5 VDC (6VDC Max.)
Resolution	12-bit
Conversion Time	50ms
Input Impedance	20kΩ
Input Stability	±2 LSB maximum
Full-Scale Calibration Error	±2% maximum
Offset Calibration Error	±25mV maximum
Accuracy vs. Temperature Error	±100ppm/°C maximum

Analog Voltage Input Circuit

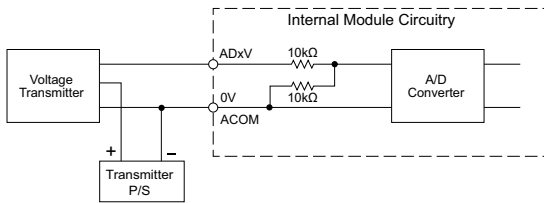

AD1I - AD2I

Analog Specifications - Current Input	
Inputs per Module	2 (voltage/current selectable)
Input Range	4-20 mA (sink)
Resolution	12-bit
Conversion Time	50ms
Input Impedance	125Ω
Input Stability	±2 LSB maximum
Full-Scale Calibration Error	±2% maximum
Offset Calibration Error	±0.1 mA maximum
Accuracy vs. Temperature Error	±100ppm/°C maximum

Analog Current Input Circuit

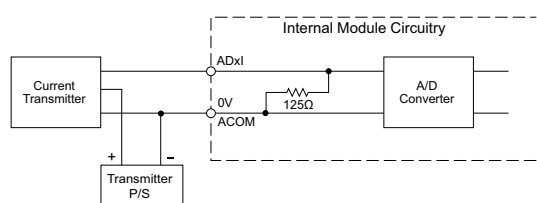

DA1V - DA2V

Analog Specifications - Voltage Output	
Outputs per Module	2 (voltage/current selectable)
Output Range	0-5 VDC
Resolution	12-bit
Conversion Time	1ms
Load Impedance	2kΩ minimum (output current 2.5 mA maximum)
Full-Scale Calibration Error	±2% maximum
Offset Calibration Error	±25mV maximum
Accuracy vs. Temperature Error	±100ppm/°C maximum

Analog Voltage Output Circuit

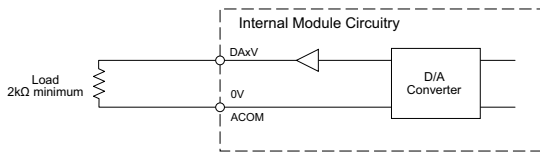

DA1I - DA2I

Analog Specifications - Current Output	
Outputs per Module	2 (voltage/current selectable)
Output Range	4-20 mA (sink)
Resolution	12-bit
Conversion Time	1ms
Loop Supply Voltage	DC 18-30 V
Load Impedance	250Ω Load Power Supply: DC 18V: 600Ω maximum DC 24V: 900Ω maximum DC 30V: 1200Ω maximum
Full-Scale Calibration Error	±2% maximum
Offset Calibration Error	±25mA maximum
Accuracy vs. Temperature Error	±100ppm/°C maximum

Analog Current Output Circuit

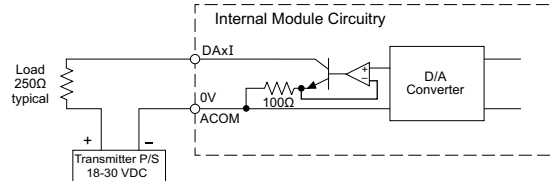

C2-08AR-4VC (continued)**Insulation Requirements for IEC/UL 61010-1 and 61010-2-201 (sections 6.5 and 6.7)****Input to Output Insulation**

Basic insulation is provided between the Relay Output and the closest Input terminal. When connecting the Relay Output to a circuit that exceeds 100VAC (141VDC) more than the closest input circuit an additional basic insulation layer must be added to the input circuit.

Additional Basic Insulation Examples

- Supplementary Insulation: Interposing relay, additional insulating material,... (sec. 6.5.3)
- Automatic Disconnection of the Supply: Properly sized breaker (sec. 6.5.5)
- Current or Voltage Limiting device: Properly sized fuse (sec. 6.5.6)

Basic insulation requires a clearance distance of 1.5 mm or more, a creepage distance of 2.5 mm or more, and dielectric voltage withstand of 1500Vrms.

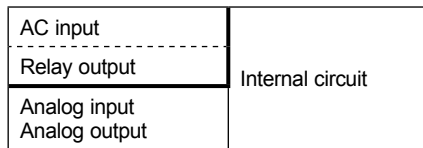

————— : No insulation

----- : Basic insulation

————— : Reinforced insulation

C2-08D1-6C – 4 DC Input (Sink/Source)/4 Sinking DC Output

4 Analog Current Input

2 Analog Current Output Option Slot I/O Module

Wiring Diagram

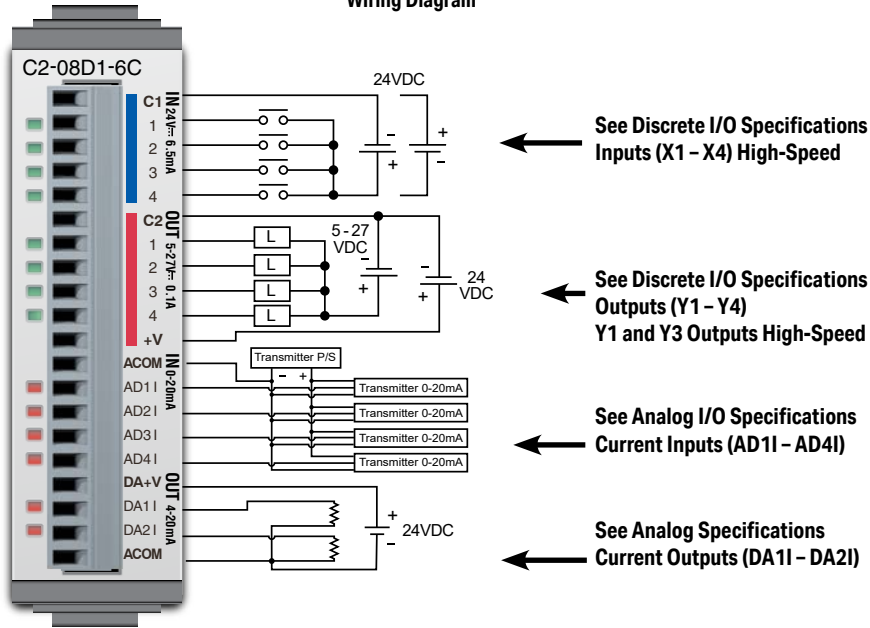

General Specifications	
Current Consumption at 24VDC	80mA max (All Points On)
Terminal Block Replacement Part No.	C0-16TB
Weight	48g

NOTE: Please refer to the Analog I/O Configuration section in Chapter 3 for information on using the analog I/O.



NOTE: There are no ZIPLink pre-wired PLC connection cables and modules for the Analog Option Slot Modules (cannot mix discrete I/O and analog I/O signals in a ZIPLink cable).

C2-08D1-6C (continued)

X1 - X4

Discrete I/O Specifications - Inputs	
Inputs per Module	4 (Sink/Source)
Operating Voltage Range	24VDC
Input Voltage Range	21.6 – 26.4 VDC
Input Current	Typ 6.5 mA @ 24VDC
Maximum Input Current	7mA @ 26.4 VDC
Input Impedance	3.9 kΩ @ 24VDC
Input Frequency (Max)	X1-X4: 100kHz (3m cable)
ON Voltage Level	>19VDC
OFF Voltage Level	< 2VDC
Minimum ON Current	4.5 mA
Maximum OFF Current	0.5 mA
OFF to ON Response	Typ 3μs Max 5μs
ON to OFF Response	Typ 1μs Max 3μs
Status Indicators	Logic Side (4 points, green LED)
Commons	1 (4 points/common)

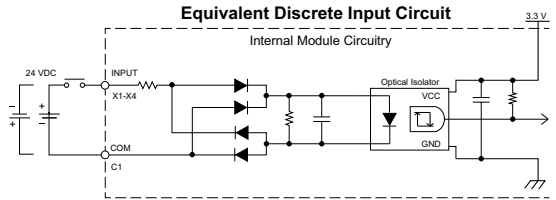

Maximum Number of High Speed Counters	
Up	4
Down	4
Up/Down	2
Pulse/Direction	2
Quadrature A-B	2
Quadrature A-B+Z	1

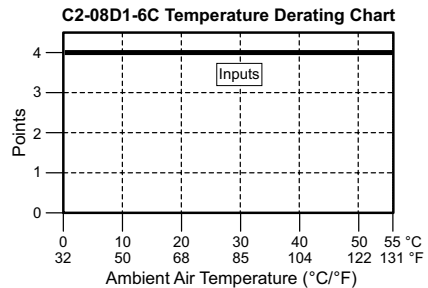

Y1 - Y4

Discrete I/O Specifications - Outputs	
Outputs per Module	4 (Sink)
Operating Voltage Range	5–27 VDC
Maximum Output Current	0.1 A/point; 0.4 A/common
Minimum Output Current	0.2 mA
Maximum Leakage Current	0.1 mA @ 30.0 VDC
On Voltage Drop	0.5 VDC @ 0.1 A
Maximum Inrush Current	150mA for 10ms
Output Frequency (Max)	Y1, Y3: 100kHz (3m cable)
OFF to ON Response	< 5μs (Duty 40–60%, Load current 20mA)
ON to OFF Response	< 5μs (Duty 40–60%, Load current 20mA)
Status Indicators	Logic Side (4 points, red LED)
Commons	1 (4 points/common)
External DC Power Required	20–28 VDC Maximum @ 60mA (All points on)

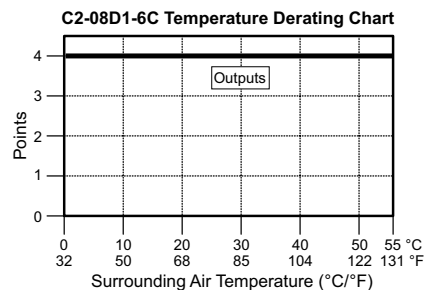
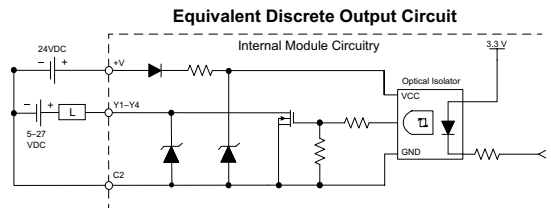

Maximum Number of High Speed Outputs	
Pulse Train	2
Pulse Width Modulation	2

AD1I - AD4I

Analog Specifications - Current Input	
Inputs per Module	4 (current)
Input Range	0–20 mA (sink)
Resolution	12-bit
Conversion Time	50ms
Input Impedance	125Ω
Input Stability	±2 LSB maximum
Full-Scale Calibration Error	±2% maximum
Offset Calibration Error	±0.1 mA maximum
Accuracy vs. Temperature Error	±120ppm/°C maximum

Analog Current Input Circuit

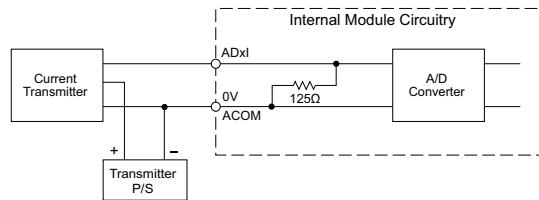

DA1I - DA2I

Analog Specifications - Current Output	
Outputs per Module	2 (current)
Output Range	4–20 mA (source)
Resolution	12-bit
Conversion Time	2.5 ms
Load Impedance	250Ω TYP (200–800 Ω)
Loop Supply Voltage	DC 24V TYP (21.6 – 26.4 VDC)
Full-Scale Calibration Error	±2% maximum
Offset Calibration Error	±25mA maximum
Accuracy vs. Temperature Error	±120ppm/°C maximum
External DC Power Required	21.6 – 26.4 VDC

Analog Current Output Circuit

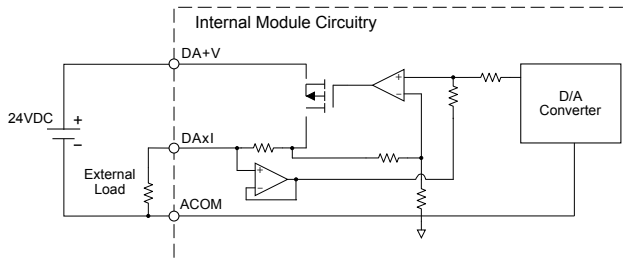

C2-08D2-6C – 4 DC Input (Sink/Source)/4 Sourcing DC Output

4 Analog Current Input

2 Analog Current Output Option Slot I/O Module

Wiring Diagram

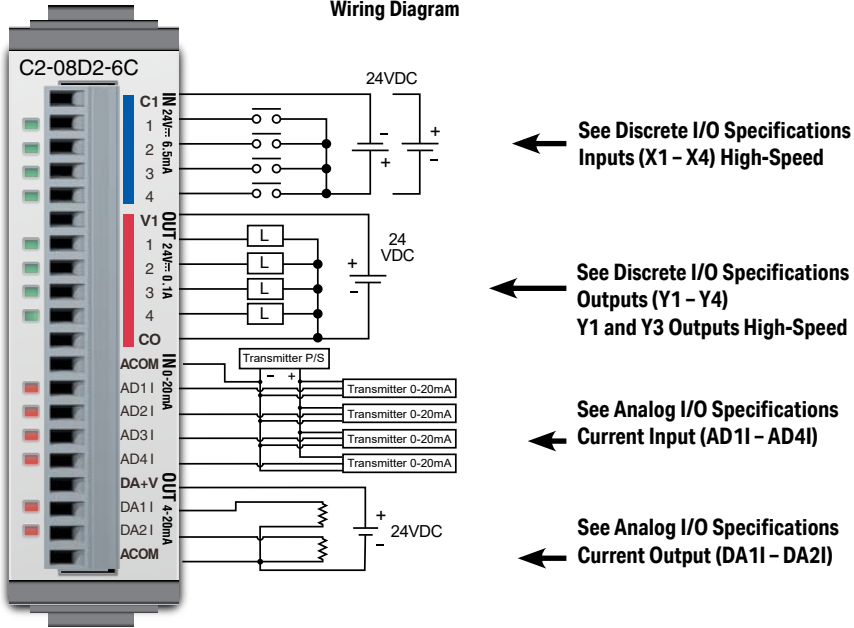

General Specifications	
Current Consumption at 24VDC	80mA max (All Points On)
Terminal Block Replacement Part No.	C0-16TB
Weight	48g

NOTE: Please refer to the Analog I/O Configuration section in Chapter 3 for information on using the analog I/O.

NOTE: There are no ZIPLink pre-wired PLC connection cables and modules for the Analog Option Slot Modules (cannot mix discrete I/O and analog I/O signals in a ZIPLink cable).



Chapter 2: Specifications

C2-08D2-6C (continued)

X1 - X4

Discrete I/O Specifications - Inputs	
Inputs per Module	4 (Sink/Source)
Operating Voltage Range	24VDC
Input Voltage Range	21.6 – 26.4 VDC
Input Current	Typ 6.5 mA @ 24VDC
Maximum Input Current	7mA @ 26.4 VDC
Input Impedance	3.9 kΩ @ 24VDC
Input Frequency (Max)	X1-X4: 100kHz (3m cable)
ON Voltage Level	>19VDC
OFF Voltage Level	< 2VDC
Minimum ON Current	4.5 mA
Maximum OFF Current	0.5 mA
OFF to ON Response	Typ 3μs Max 5μs
ON to OFF Response	Typ 1μs Max 3μs
Status Indicators	Logic Side (4 points, green LED)
Commons	1 (4 points/common)

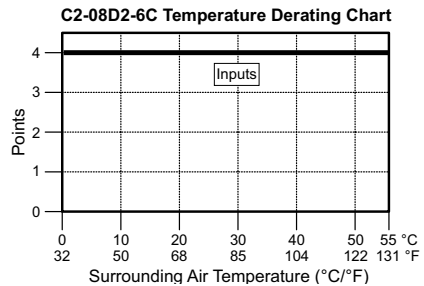
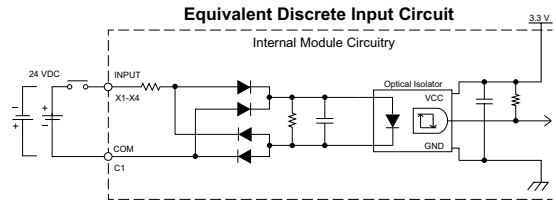

Maximum Number of High Speed Counters	
Up	4
Down	4
Up/Down	2
Pulse/Direction	2
Quadrature A-B	2
Quadrature A-B+Z	1

Y1 - Y4

Discrete I/O Specifications - Outputs	
Outputs per Module	4 (Source)
Operating Voltage Range	19.2–30 VDC
Maximum Output Current	0.1 A/point; 0.4 A/common C0
Minimum Output Current	0.2 mA
Maximum Leakage Current	0.1 mA @ 30.0 VDC
On Voltage Drop	0.5 VDC @ 0.1 A
Maximum Inrush Current	150mA for 10ms
Output Frequency (Max)	Y1, Y3: 100kHz (3m cable)
OFF to ON Response	< 5μs (Duty 40–60%, Load current 20mA)
ON to OFF Response	< 5μs (Duty 40–60%, Load current 20mA)
Status Indicators	Logic side (4 points, red LED)
Commons	1 (4 points/common)

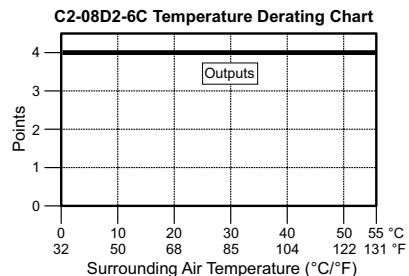
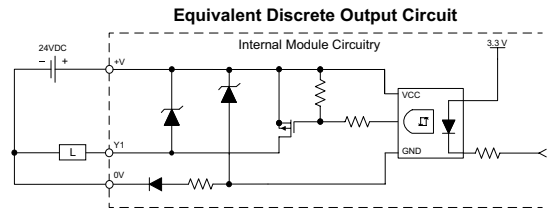

Maximum Number of High Speed Outputs	
Pulse Train	2
Pulse Width Modulation	2

C2-08D2-6C (continued)

AD1I - AD4I

Analog Specifications - Current Input	
Inputs per Module	4 (current)
Input Range	0–20 mA (sink)
Resolution	12-bit
Conversion Time	50ms
Input Impedance	125Ω
Input Stability	±2 LSB maximum
Full-Scale Calibration Error	±2% maximum
Offset Calibration Error	±0.1 mA maximum
Accuracy vs. Temperature Error	±100ppm/°C maximum

Analog Current Input Circuit

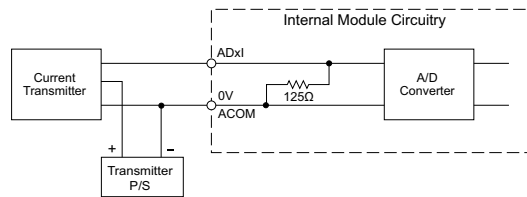

DA1I - DA2I

Analog Specifications - Current Output	
Outputs per Module	2 (current)
Output Range	4–20 mA (source)
Resolution	12-bit
Conversion Time	2.5 ms
Load Impedance	250Ω Typ (200Ω to 800Ω)
Loop Supply Voltage	24VDC Typ (21.6 – 26.4 VDC)
Full-Scale Calibration Error	±2% maximum
Offset Calibration Error	±25mA maximum
Accuracy vs. Temperature Error	±120ppm/°C maximum
External DC Power Required	21.6 – 26.4 VDC

Analog Current Output Circuit

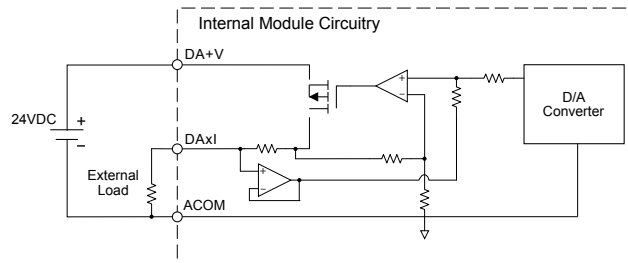

C2-08DR-6C – 4 DC Input (Sink/Source)/4 Relay Output

4 Analog Current Input

2 Analog Current Output Option Slot I/O Module

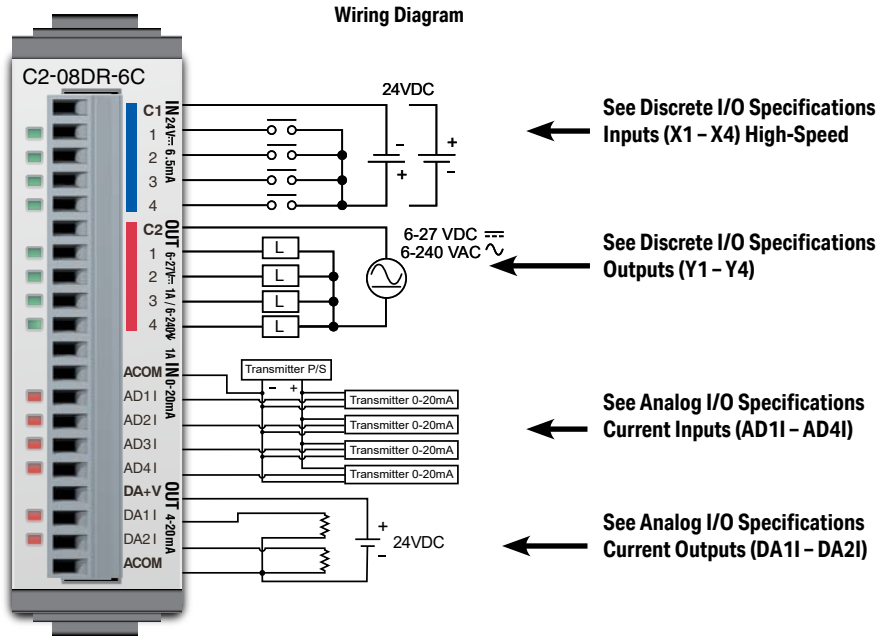

General Specifications	
Current Consumption at 24VDC	100mA max (All Points On)
Terminal Block Replacement Part No.	CO-16TB
Weight	58g

NOTE: Please refer to the Analog I/O Configuration section in Chapter 3 for information on using the analog I/O.



NOTE: There are no ZIPLink pre-wired PLC connection cables and modules for the Analog Option Slot Modules (cannot mix discrete I/O and analog I/O signals in a ZIPLink cable).

C2-08DR-6C (continued)

X1 - X4

Discrete I/O Specifications - Inputs	
Inputs per Module	4
Operating Voltage Range	24VDC
Input Voltage Range	21.6 – 26.4 VDC
Input Current	Typ 6.5 mA @ 24VDC
Max. Input Current	7mA @ 26.4 VDC
Input Impedance	3.9 kΩ @ 24VDC
Input Frequency (Max)	X1-X4: 100kHz (3m cable)
ON Voltage Level	>19VDC
OFF Voltage Level	< 2VDC
Minimum ON Current	4.5 mA
Maximum OFF Current	0.5 mA
OFF to ON Response	Typ 3μs Max 5μs
ON to OFF Response	Typ 1μs Max 3μs
Status Indicators	Logic Side (4 points, green LED)
Commons	1 (4 points/common)

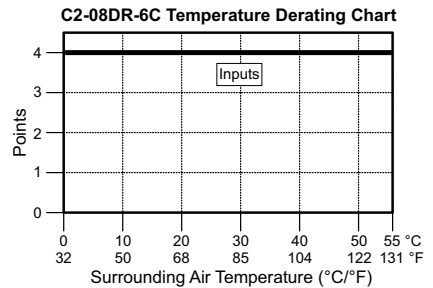
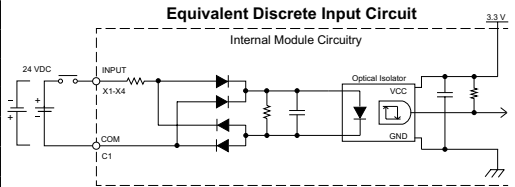

Maximum Number of High Speed Counters	
Up	4
Down	4
Up/Down	2
Pulse/Direction	2
Quadrature A-B	2
Quadrature A-B+Z	1

Equivalent Discrete Output Circuit

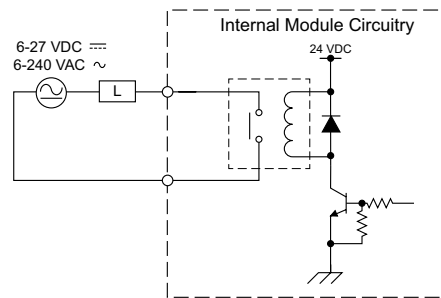

Y1 - Y4

Discrete I/O Specifications - Outputs	
Outputs per Module	4
Operating Voltage Range	6-27 VDC, 6-240 VAC
Output Type	Relay, form A (SPST)
AC Frequency	47-63 Hz
Maximum Current	1A/point (resistive)
Minimum Load Current	5mA @ 5VDC
Maximum Inrush Current	3A for 10ms
OFF to ON Response	< 15ms
ON to OFF Response	< 15ms
Status Indicators	Logic Side (4 points, red LED)
Commons	1 (4 points/common)

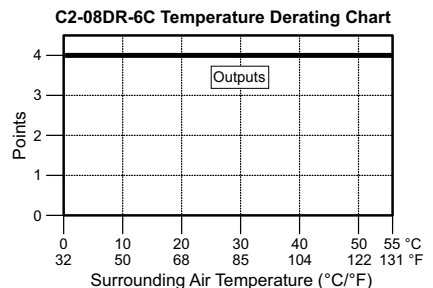

Typical Relay Life (Operations) at Room Temperature	
Voltage & Load Type	Relay Life
30VDC, 1A Resistive	200,000 cycles
30VDC, 1A Inductive	100,000 cycles
250VAC, 1A Resistive	200,000 cycles
250VAC, 1A Inductive	50,000 cycles

ON to OFF = 1 cycle

AD1I - AD4I

Analog Specifications - Current Input	
Inputs per Module	4 (Current)
Input Range	0–20 mA (Sink)
Resolution	12-bit
Conversion Time	50ms
Input Impedance	125Ω
Input Stability	±2 LSB maximum
Full-Scale Calibration Error	±2% maximum
Offset Calibration Error	±0.1 mA maximum
Accuracy vs. Temperature Error	±100ppm/°C maximum

Analog Current Input Circuit

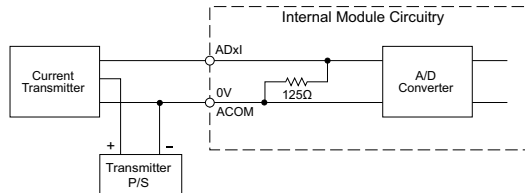

DA1I - DA2I

Analog Specifications - Current Output	
Outputs per Module	2 (Current)
Output Range	4–20 mA (Source)
Resolution	12-bit
Conversion Time	2.5 ms
Load Impedance	250Ω Typ (200Ω to 800Ω)
Loop Supply Voltage	24VDC Typ (21.6–26.4)
Full-Scale Calibration Error	±2% maximum
Offset Calibration Error	±25mA maximum
Accuracy vs. Temperature Error	±120ppm/°C maximum
External DC Power Required	21.6 – 26.4 VDC

Analog Current Output Circuit

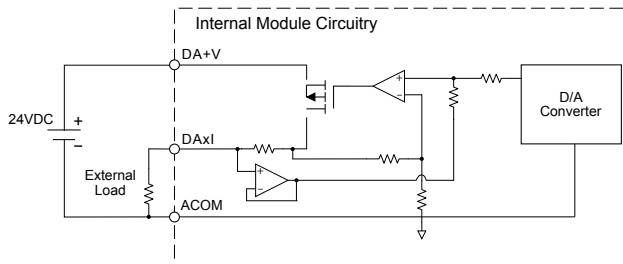

C2-08DR-6C (continued)

Insulation Requirements for IEC/UL 61010-1 and 61010-2-201 (sections 6.5 and 6.7)**Input to Output Insulation**

Basic insulation is provided between the Relay Output and the closest Input terminal. When connecting the Relay Output to a circuit that exceeds 100VAC (141VDC) more than the closest input circuit an additional basic insulation layer must be added to the input circuit.

Additional Basic Insulation Examples

- Supplementary Insulation: Interposing relay, additional insulating material,... (sec. 6.5.3)
- Automatic Disconnection of the Supply: Properly sized breaker (sec. 6.5.5)
- Current or Voltage Limiting device: Properly sized fuse (sec. 6.5.6)

Basic insulation requires a clearance distance of 1.5 mm or more, a creepage distance of 2.5 mm or more, and dielectric voltage withstand of 1500Vrms.

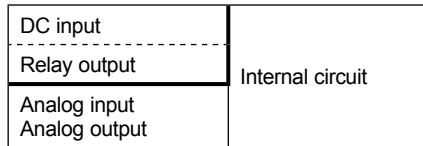

————— : No insulation

----- : Basic insulation

————— : Reinforced insulation

C2-08AR-6C – 4 AC Input/4 Relay Output

4 Analog Current Input

2 Analog Current Output Option Slot I/O Module

Wiring Diagram

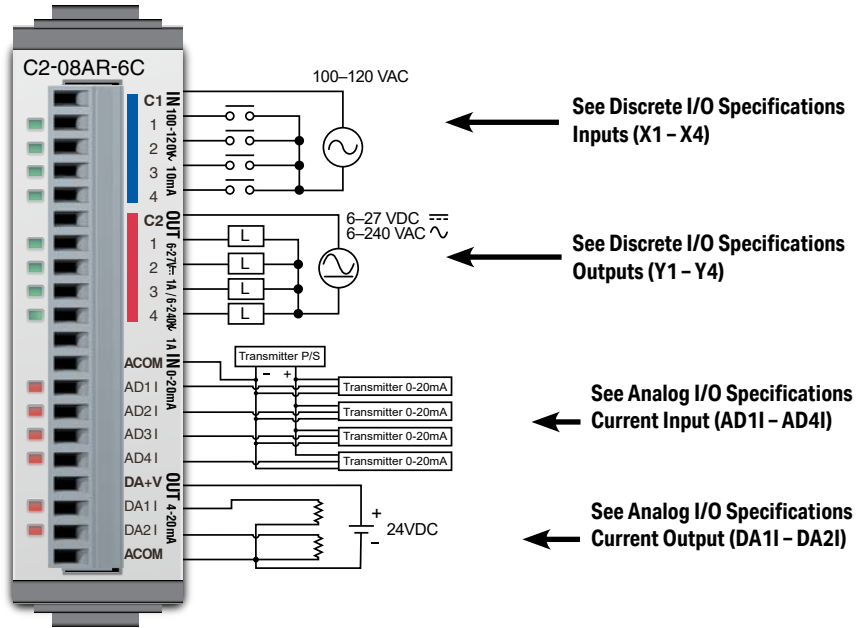

General Specifications	
Current Consumption at 24VDC	100mA max (All Points On)
Terminal Block Replacement Part No.	C0-16TB
Weight	58g

NOTE: Please refer to the Analog I/O Configuration section in Chapter 3 for information on using the analog I/O.



NOTE: There are no ZIPLink pre-wired PLC connection cables and modules for the Analog Option Slot Modules (cannot mix discrete I/O and analog I/O signals in a ZIPLink cable).

C2-08AR-6C (continued)

X1 - X4

Discrete I/O Specifications - Inputs	
Inputs per Module	4
Operating Voltage Range	100-120 VAC
AC Frequency	47-63 Hz
Input Current	Typ 8.5 mA @ 100VAC at 50Hz Typ 10mA @ 100VAC at 60Hz
Maximum Input Current	16mA @ 144VAC
Input Impedance	15kΩ @ 50Hz 12kΩ @ 60Hz
ON Voltage Level	> 60VAC
OFF Voltage Level	< 20VAC
Minimum ON Current	5mA
Maximum OFF Current	2mA
OFF to ON Response	< 40ms
ON to OFF Response	< 40ms
Status Indicators	Logic Side (4 points, green LED)
Commons	1 (4 points/common)

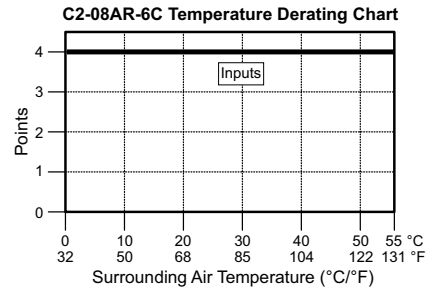
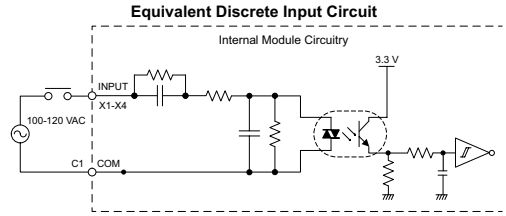

Y1 - Y4

Discrete I/O Specifications - Outputs	
Outputs per Module	4
Operating Voltage Range	6-27 VDC, 6-240 VAC
Output Type	Relay, form A (SPST)
AC Frequency	47-63 Hz
Maximum Current	1A/point (resistive)
Minimum Load Current	5mA @ 5VDC
Maximum Inrush Current	3A for 10ms
OFF to ON Response	< 15ms
ON to OFF Response	< 15ms
Status Indicators	Logic Side (4 points, red LED)
Commons per Module	1 (4 points/common)

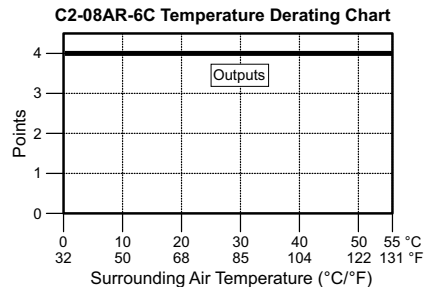
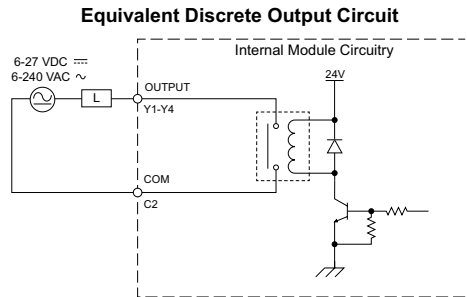

Typical Relay Life (Operations) at Room Temperature	
Voltage & Load Type	Relay Life
30VDC, 1A Resistive	200,000 cycles
30VDC, 1A Inductive	100,000 cycles
250VAC, 1A Resistive	200,000 cycles
250VAC, 1A Inductive	50,000 cycles

ON to OFF = 1 cycle

AD1I – AD4I

Analog Specifications - Current Input	
Inputs per Module	4 (current)
Input Range	0–20 mA (sink)
Resolution	12-bit
Conversion Time	50ms
Input Impedance	125Ω
Input Stability	±2 LSB maximum
Full-Scale Calibration Error	±2% maximum
Offset Calibration Error	±0.1 mA maximum
Accuracy vs. Temperature Error	±100ppm/°C maximum

Analog Current Input Circuit

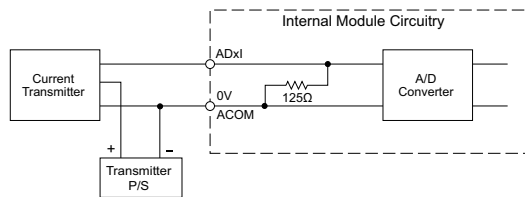

DA1I – DA2I

Analog Specifications - Current Output	
Outputs per Module	2 (current)
Output Range	4–20 mA (source)
Resolution	12-bit
Conversion Time	2.5 ms
Load Impedance	250Ω Typ (200Ω to 800Ω)
Loop Supply Voltage	DC 24V Typ (21.6 – 26.4 V)
Full-Scale Calibration Error	±2% maximum
Offset Calibration Error	±25mA maximum
Accuracy vs. Temperature Error	±120ppm/°C maximum
External DC Power Supply Required	21.6–26.4 VDC

Analog Current Output Circuit

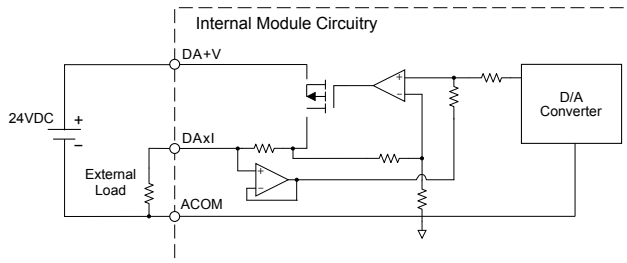

C2-08AR-6C (continued)

Insulation Requirements for IEC/UL 61010-1 and 61010-2-201 (sections 6.5 and 6.7)**Input to Output Insulation**

Basic insulation is provided between the Relay Output and the closest Input terminal. When connecting the Relay Output to a circuit that exceeds 100VAC (141VDC) more than the closest input circuit an additional basic insulation layer must be added to the input circuit.

Additional Basic Insulation Examples

- Supplementary Insulation: Interposing relay, additional insulating material,... (sec. 6.5.3)
- Automatic Disconnection of the Supply: Properly sized breaker (sec. 6.5.5)
- Current or Voltage Limiting device: Properly sized fuse (sec. 6.5.6)

Basic insulation requires a clearance distance of 1.5 mm or more, a creepage distance of 2.5 mm or more, and dielectric voltage withstand of 1500Vrms.

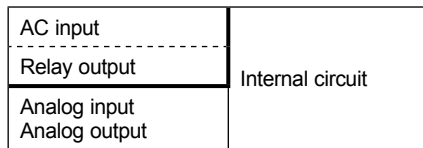

————— : No insulation

----- : Basic insulation

————— : Reinforced insulation

C2-08D1-6V – 4 DC Input (Sink/Source)/4 Sinking DC Output

4 Analog Voltage Input

2 Analog Voltage Output Option Slot I/O Module

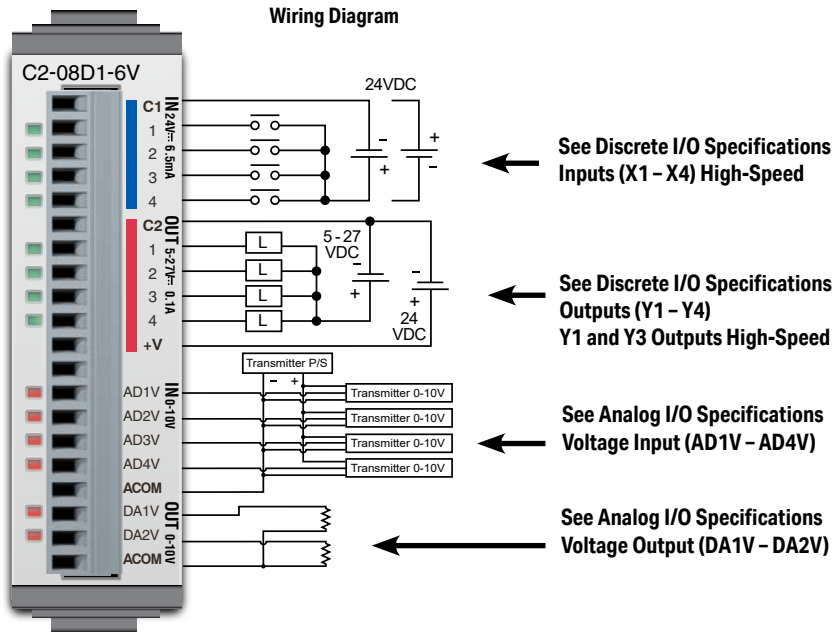

General Specifications	
Current Consumption at 24VDC	80mA max (All Points On)
Terminal Block Replacement Part No.	C0-16TB
Weight	48g

NOTE: Please refer to the Analog I/O Configuration section in Chapter 3 for information on using the analog I/O.



NOTE: There are no ZIPLink pre-wired PLC connection cables and modules for the Analog Option Slot Modules (cannot mix discrete I/O and analog I/O signals in a ZIPLink cable).

C2-08D1-6V (continued)

X1 - X4

Discrete I/O Specifications - Inputs	
Inputs per Module	4 (Source/Sink)
Operating Voltage Range	24VDC
Input Voltage Range	21.6 - 26.4 VDC
Input Current	Typ 6.5 mA @ 24VDC
Max. Input Current	7mA @ 26.4 VDC
Input Impedance	3.9 kΩ @ 24VDC
Input Frequency (Max)	X1-X4: 100kHz (3m cable)
ON Voltage Level	>19VDC
OFF Voltage Level	< 2VDC
Minimum ON Current	4.5 mA
Maximum OFF Current	0.5 mA
OFF to ON Response	Typ 3μs Max 5μs
ON to OFF Response	Typ 1μs Max 3μs
Status Indicators	Logic Side (4 points, green LED)
Commons	1 (4 points/common)

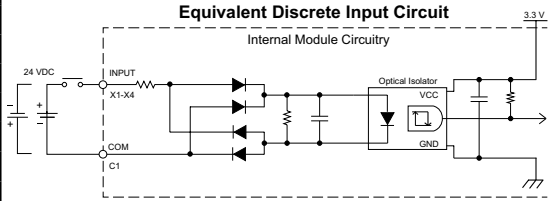

C2-08D1-6V Temperature Derating Chart

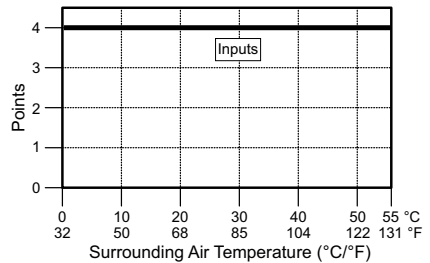

Maximum Number of High Speed Counters	
Up	4
Down	4
Up/Down	2
Pulse/Direction	2
Quadrature A-B	2
Quadrature A-B+Z	1

Y1 - Y4

Discrete I/O Specifications - Outputs	
Outputs per Module	4 (Sink)
Operating Voltage Range	5-27 VDC
Maximum Output Current	0.1 A/point; 0.4 A/common
Minimum Output Current	0.2 mA
Maximum Leakage Current	0.1 mA @ 30.0 VDC
On Voltage Drop	0.5 VDC @ 0.1 A
Maximum Inrush Current	150 mA for 10ms
Output Frequency (Max)	Y1, Y3: 100kHz (3m cable)
OFF to ON Response	< 5μs (Duty 40-60%, Load current 20mA)
ON to OFF Response	< 5μs (Duty 40-60%, Load current 20mA)
Status Indicators	Logic Side (4 points, red LED)
Commons	1 (4 points/common)
External DC Power Required	20-28 VDC Maximum @ 60mA (All points on)

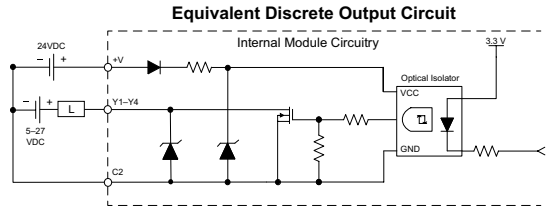

C2-08D1-6V Temperature Derating Chart

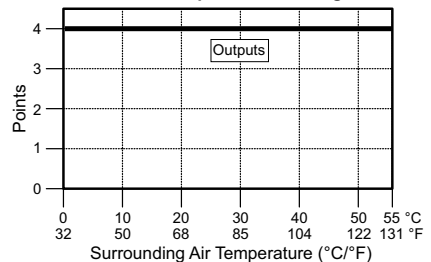

Maximum Number of High Speed Outputs	
Pulse Train	2
Pulse Width Modulation	2

AD1V - AD4V

Analog Specifications - Voltage Input	
Inputs per Module	4 (voltage)
Input Range	0-10 VDC
Resolution	12-bit
Conversion Time	50ms
Input Impedance	40kΩ
Input Stability	±2 LSB maximum
Full-Scale Calibration Error	±2% maximum
Offset Calibration Error	±25mV maximum
Accuracy vs. Temperature Error	±100ppm/°C maximum

Analog Voltage Input Circuit

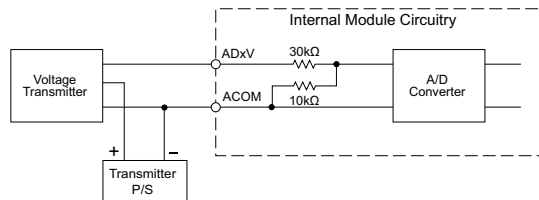

DA1V - DA2V

Analog Specifications - Voltage Output	
Outputs per Module	2 (voltage)
Output Range	0-10 VDC
Resolution	12-bit
Conversion Time	1ms
Load Impedance	4kΩ minimum (output current 2.5 mA maximum)
Full-Scale Calibration Error	±2% maximum
Offset Calibration Error	±25mV maximum
Accuracy vs. Temperature Error	±100ppm/°C maximum

Analog Voltage Output Circuit

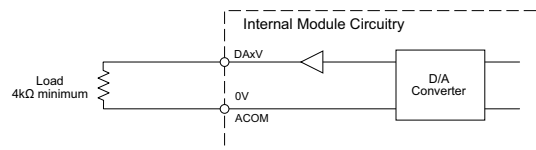

C2-08D2-6V – 4 DC Input (Sink/Source)/4 Sourcing DC Output

4 Analog Voltage Input

2 Analog Voltage Output Option Slot I/O Module

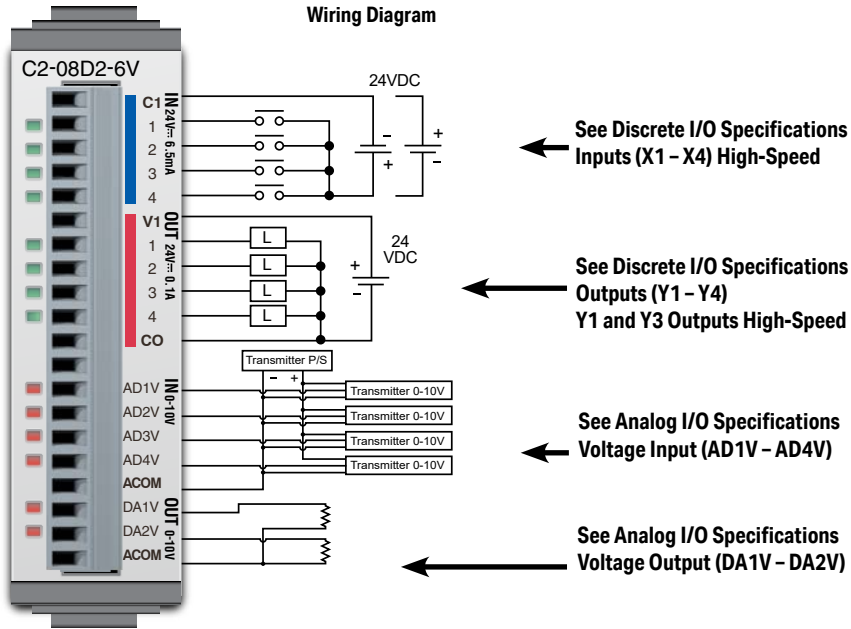

General Specifications	
Current Consumption at 24VDC	80mA max (All Points On)
Terminal Block Replacement Part No.	CO-16TB
Weight	48g

NOTE: Please refer to the Analog I/O Configuration section in Chapter 3 for information on using the analog I/O.

NOTE: There are no ZIPLink pre-wired PLC connection cables and modules for the Analog Option Slot Modules (cannot mix discrete I/O and analog I/O signals in a ZIPLink cable).



X1 - X4

Discrete I/O Specifications - Inputs	
Inputs per Module	4 (Source/Sink)
Operating Voltage Range	24VDC
Input Voltage Range	21.6 – 26.4 VDC
Input Current	Typ 6.5 mA @ 24VDC
Max. Input Current	7mA @ 26.4 VDC
Input Impedance	3.9 kΩ @ 24VDC
Input Frequency (Max)	X1-X4: 100kHz (3m cable)
ON Voltage Level	>19VDC
OFF Voltage Level	< 2VDC
Minimum ON Current	4.5 mA
Maximum OFF Current	0.5 mA
OFF to ON Response	Typ 3μs Max 5μs
ON to OFF Response	Typ 1μs Max 3μs
Status Indicators	Logic Side (4 points, green LED)
Commons	1 (4 points/common)

Maximum Number of High Speed Counters	
Up	4
Down	4
Up/Down	2
Pulse/Direction	2
Quadrature A-B	2
Quadrature A-B+Z	1

Y1 - Y4

Discrete I/O Specifications - Outputs	
Outputs per Module	4 (Source)
Operating Voltage Range	24VDC
Output Voltage Range	19.2-30 VDC
Maximum Output Current	0.1 A/point , 0.4 A/common
Minimum Output Current	0.2 mA
Maximum Leakage Current	0.1mA @ 30VDC
On Voltage Drop	0.5 VDC@ 0.1 mA
Maximum Inrush Current	150mA for 10ms
Output Frequency (Max)	Y1, Y3: 100kHz (3m cable)
OFF to ON Response	< 5μs (Duty 40–60%, Load current 20mA)
ON to OFF Response	< 5μs (Duty 40–60%, Load current 20mA)
Status Indicators	Logic Side (4 points, red LED)
Commons	1 (4 points/common)

Maximum Number of High Speed Outputs	
Pulse Train	2
Pulse Width Modulation	2

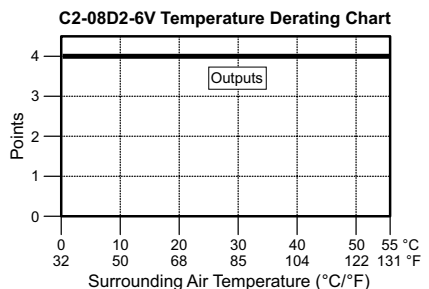
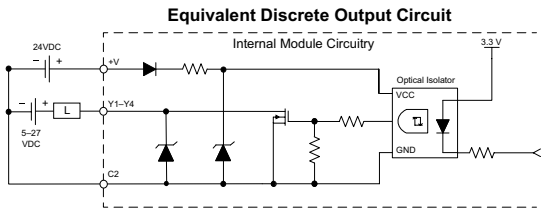
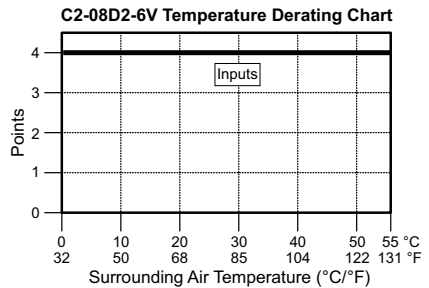
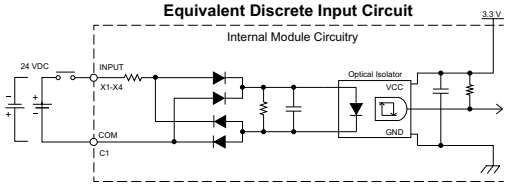

C2-08D2-6V (continued)

AD1V - AD4V

Analog Specifications - Voltage Input	
Inputs per Module	4 (voltage)
Input Range	0–10 VDC
Resolution	12-bit
Conversion Time	50ms
Input Impedance	40kΩ
Input Stability	±2 LSB maximum
Full-Scale Calibration Error	±2% maximum
Offset Calibration Error	±25mV maximum
Accuracy vs. Temperature Error	±100ppm/°C maximum

Analog Voltage Input Circuit

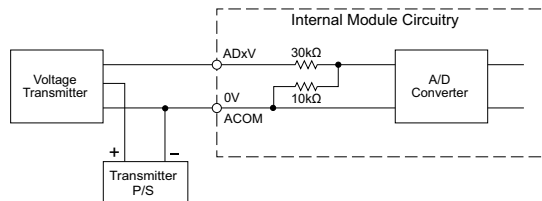

DA1V - DA2V

Analog Specifications - Voltage Output	
Outputs per Module	2 (voltage)
Output Range	0–10 VDC
Resolution	12-bit
Conversion Time	1ms
Load Impedance	4kΩ minimum (output current 2.5 mA maximum)
Full-Scale Calibration Error	±2% maximum
Offset Calibration Error	±25mV maximum
Accuracy vs. Temperature Error	±100ppm/°C maximum

Analog Voltage Output Circuit

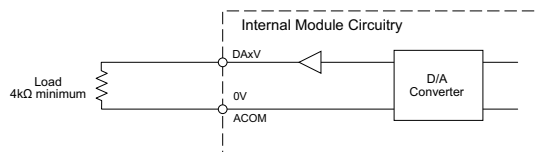

C2-08DR-6V – 4 DC Input (Sink/Source)/4 Relay Output

4 Analog Voltage Input

2 Analog Voltage Output Option Slot I/O Module

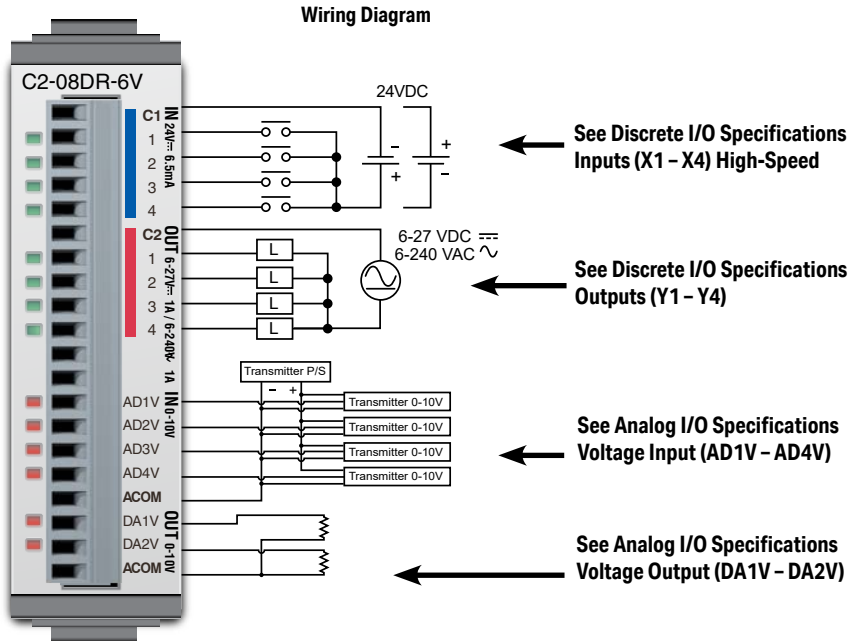

General Specifications	
Current Consumption at 24VDC	80mA max (All Points On)
Terminal Block Replacement Part No.	C0-16TB
Weight	57g

NOTE: Please refer to the Analog I/O Configuration section in Chapter 3 for information on using the analog I/O.



NOTE: There are no ZIPLink pre-wired PLC connection cables and modules for the Analog Option Slot Modules (cannot mix discrete I/O and analog I/O signals in a ZIPLink cable).

C2-08DR-6V (continued)

X1 - X4

Discrete I/O Specifications - Inputs	
Inputs per Module	4
Operating Voltage Range	24VDC
Input Voltage Range	21.6 – 26.4 VDC
Input Current	Typ 6.5 mA @ 24VDC
Max. Input Current	7mA @ 26.4 VDC
Input Impedance	3.9 kΩ @ 24VDC
Input Frequency (Max)	X1-X4: 100kHz (3m cable)
ON Voltage Level	>19VDC
OFF Voltage Level	< 2VDC
Minimum ON Current	4.5 mA
Maximum OFF Current	0.5 mA
OFF to ON Response	Typ 3μs Max 5μs
ON to OFF Response	Typ 1μs Max 3μs
Status Indicators	Logic side (4 points, green LED)
Commons	1 (4 points/common)

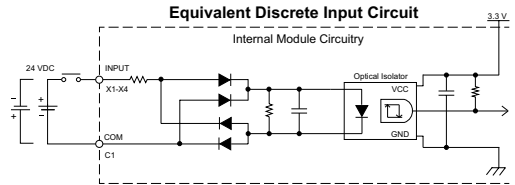

C2-08DR-6V Temperature Derating Chart

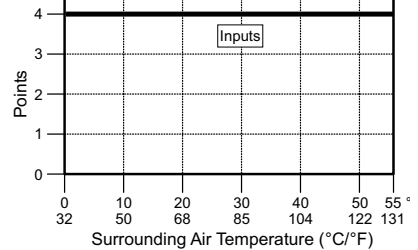

Y1 - Y4

Maximum Number of High Speed Counters	
Up	4
Down	4
Up/Down	2
Pulse/Direction	2
Quadrature A-B	2
Quadrature A-B+Z	1

Discrete I/O Specifications - Outputs	
Outputs per Module	4
Operating Voltage Range	6–27 VDC, 6–240 VAC
Output Type	Relay, form A (SPST)
AC Frequency	47–63 Hz
Maximum Current	1A/point (resistive)
Minimum Load Current	5mA @ 5VDC
Maximum Inrush Current	3A for 10ms
OFF to ON Response	< 15ms
ON to OFF Response	< 15ms
Status Indicators	Logic Side (4 points, red LED)
Commons per Module	1 (4 points/common)

Equivalent Discrete Output Circuit

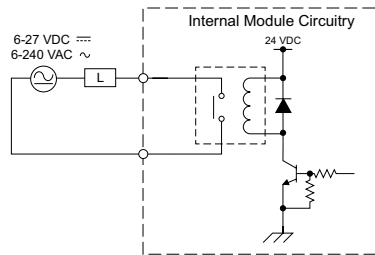

C2-08DR-6V Temperature Derating Chart

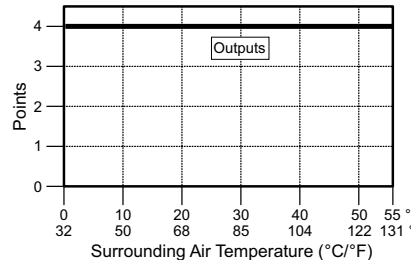

Typical Relay Life (Operations) at Room Temperature	
Voltage & Load Type	Relay Life
30VDC, 1A Resistive	200,000 cycles
30VDC, 1A Inductive	100,000 cycles
250VAC, 1A Resistive	200,000 cycles
250VAC, 1A Inductive	50,000 cycles

ON to OFF = 1 cycle

AD1V - AD4V

Analog Specifications - Voltage Input	
Inputs per Module	4 (voltage)
Input Range	0-10 VDC
Resolution	12-bit
Conversion Time	50ms
Input Impedance	40kΩ
Input Stability	±2 LSB maximum
Full-Scale Calibration Error	±2% maximum
Offset Calibration Error	±25mV maximum
Accuracy vs. Temperature Error	±100ppm/°C maximum

Analog Voltage Input Circuit

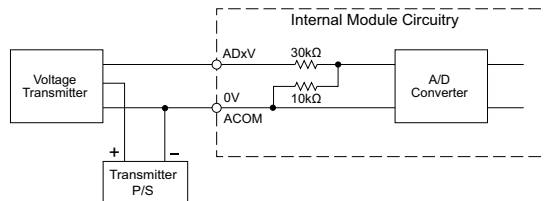

DA1V - DA2V

Analog Specifications - Voltage Output	
Outputs per Module	2 (voltage)
Output Range	0-10 VDC
Resolution	12-bit
Conversion Time	1ms
Load Impedance	4kΩ minimum (output current 2.5 mA maximum)
Full-Scale Calibration Error	±2% maximum
Offset Calibration Error	±25mV maximum
Accuracy vs. Temperature Error	±100ppm/°C maximum

Analog Voltage Output Circuit

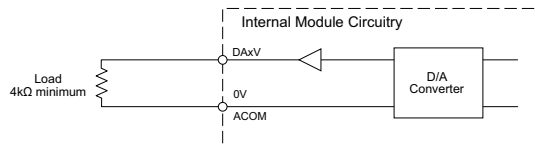

C2-08DR-6V (continued)

Insulation Requirements for IEC/UL 61010-1 and 61010-2-201 (sections 6.5 and 6.7)**Input to Output Insulation**

Basic insulation is provided between the Relay Output and the closest Input terminal. When connecting the Relay Output to a circuit that exceeds 100VAC (141VDC) more than the closest input circuit an additional basic insulation layer must be added to the input circuit.

Additional Basic Insulation Examples

- Supplementary Insulation: Interposing relay, additional insulating material,... (sec. 6.5.3)
- Automatic Disconnection of the Supply: Properly sized breaker (sec. 6.5.5)
- Current or Voltage Limiting device: Properly sized fuse (sec. 6.5.6)

Basic insulation requires a clearance distance of 1.5 mm or more, a creepage distance of 2.5 mm or more, and dielectric voltage withstand of 1500Vrms.

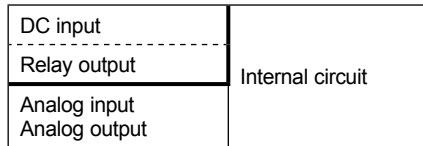

————— : No insulation

----- : Basic insulation

————— : Reinforced insulation

C2-08AR-6V – 4 AC Input (Sink/Source) /4 Relay Output

4 Analog Voltage Input

2 Analog Voltage Output Option Slot I/O Module

Wiring Diagram

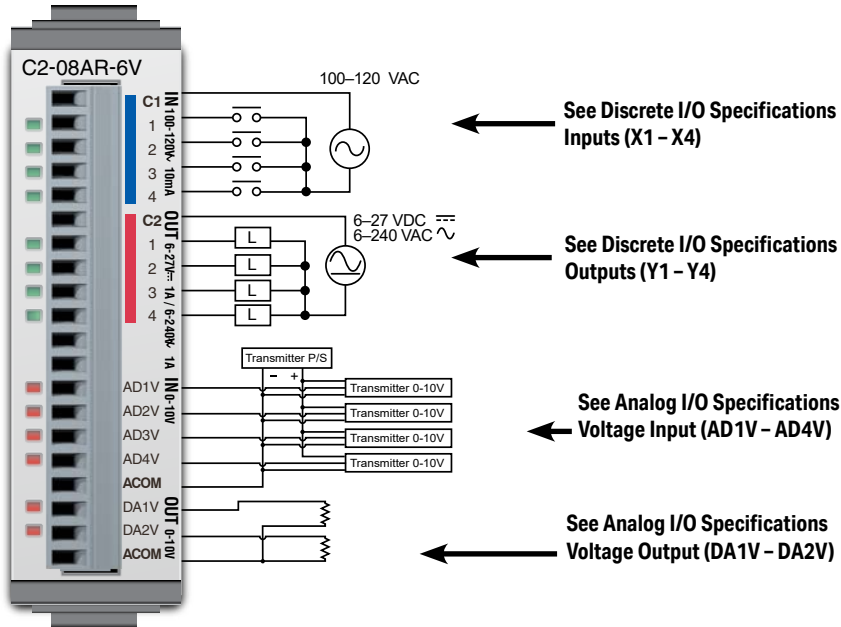

General Specifications	
Current Consumption at 24VDC	100mA max (All Points On)
Terminal Block Replacement Part No.	C0-16TB
Weight	58g

NOTE: Please refer to the Analog I/O Configuration section in Chapter 3 for information on using the analog I/O.



NOTE: There are no ZIPLink pre-wired PLC connection cables and modules for the Analog Option Slot Modules (cannot mix discrete I/O and analog I/O signals in a ZIPLink cable).

C2-08AR-6V (continued)

X1 - X4

Discrete I/O Specifications - Inputs	
Inputs per Module	4
Operating Voltage Range	100-120 VAC
AC Frequency	47-63 Hz
Input Current	Typ 8.5 mA @ 100VAC at 50Hz Typ 10mA @ 100VAC at 60Hz
Maximum Input Current	16mA @ 144VAC
Input Impedance	15kΩ @ 50Hz 12kΩ @ 60Hz
ON Voltage Level	> 60VAC
OFF Voltage Level	< 20VAC
Minimum ON Current	5mA
Maximum OFF Current	2mA
OFF to ON Response	< 40ms
ON to OFF Response	< 40ms
Status Indicators	Logic Side (4 points, green LED)
Commons	1 (4 points/common)

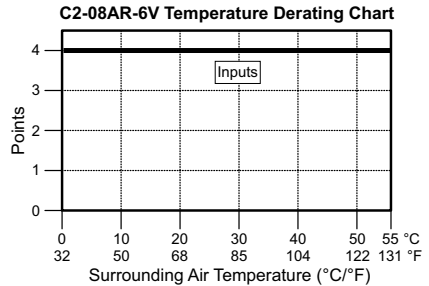
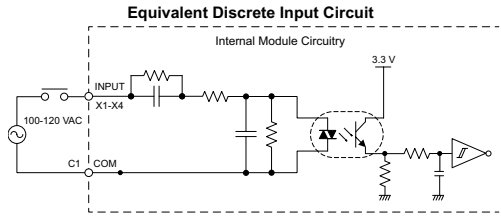

Y1 - Y4

Discrete I/O Specifications - Outputs	
Outputs per Module	4
Operating Voltage Range	6-27 VDC, 6-240 VAC
Output Type	Relay, form A (SPST)
AC Frequency	47-63 Hz
Maximum Current	1A/point (resistive)
Minimum Load Current	5mA @ 5VDC
Maximum Inrush Current	3A for 10ms
OFF to ON Response	< 15ms
ON to OFF Response	< 15ms
Status Indicators	Logic Side (4 points, red LED)
Commons per Module	1 (4 points/common)

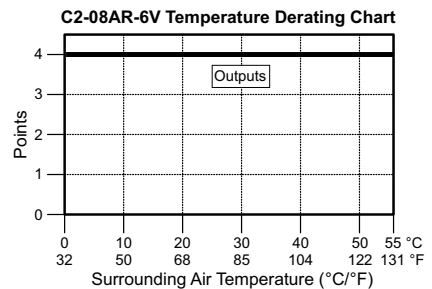
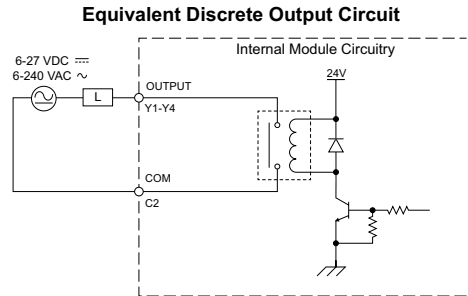

Typical Relay Life (Operations) at Room Temperature	
Voltage & Load Type	Relay Life
30VDC, 1A Resistive	200,000 cycles
30VDC, 1A Inductive	100,000 cycles
250VAC, 1A Resistive	200,000 cycles
250VAC, 1A Inductive	50,000 cycles

ON to OFF = 1 cycle

C2-08AR-6V (continued)

AD1V - AD4V

Analog Specifications - Voltage Input	
Inputs per Module	4 (voltage)
Input Range	0-10 VDC
Resolution	12-bit
Conversion Time	50ms
Input Impedance	40kΩ
Input Stability	±2 LSB maximum
Full-Scale Calibration Error	±2% maximum
Offset Calibration Error	±25mV maximum
Accuracy vs. Temperature Error	±100ppm/°C maximum

Analog Voltage Input Circuit

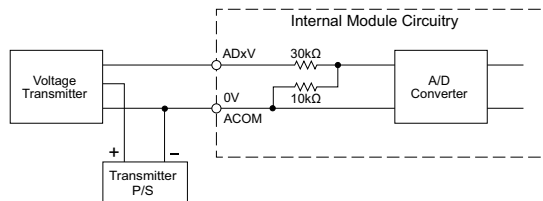

DA1V - DA2V

Analog Specifications - Voltage Output	
Outputs per Module	2 (voltage)
Output Range	0-10 VDC
Resolution	12-bit
Conversion Time	1ms
Load Impedance	4kΩ minimum (output current 2.5 mA maximum)
Full-Scale Calibration Error	±2% maximum
Offset Calibration Error	±25mV maximum
Accuracy vs. Temperature Error	±100ppm/°C maximum

Analog Voltage Output Circuit

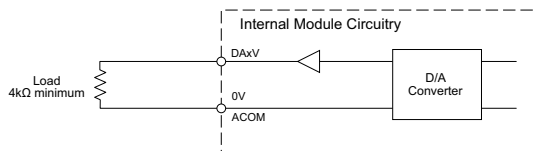

C2-08AR-6V (continued)

Insulation Requirements for IEC/UL 61010-1 and 61010-2-201 (sections 6.5 and 6.7)**Input to Output Insulation**

Basic insulation is provided between the Relay Output and the closest Input terminal. When connecting the Relay Output to a circuit that exceeds 100VAC (141VDC) more than the closest input circuit an additional basic insulation layer must be added to the input circuit.

Additional Basic Insulation Examples

- Supplementary Insulation: Interposing relay, additional insulating material,... (sec. 6.5.3)
- Automatic Disconnection of the Supply: Properly sized breaker (sec. 6.5.5)
- Current or Voltage Limiting device: Properly sized fuse (sec. 6.5.6)

Basic insulation requires a clearance distance of 1.5 mm or more, a creepage distance of 2.5 mm or more, and dielectric voltage withstand of 1500Vrms.

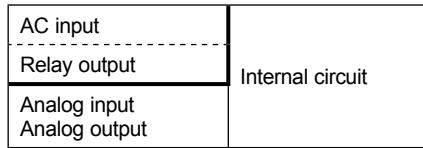

————— : No insulation

----- : Basic insulation

————— : Reinforced insulation

Option Slot Intelligent Module Specifications

General Specifications for all CLICK PLUS Option Slot Intelligent Modules

CLICK PLUS Option Slot Module General Specifications	
Operating Temperature	32°F to 131°F [0°C to 55°C]
Storage Temperature	-4°F to 158°F [-20°C to 70°C] IEC 60068-2-1 (Test Ab, Cold) IEC 60068-2-2 (Test Bb, Dry Heat) IEC 60068-2-14 (Test Na, Thermal Shock)
Ambient Humidity	30% to 95% relative humidity (non-condensing)
Environmental Air	No corrosive gases The level for the environmental pollution is 2 (UL840)
Environment	For Indoor Use Only
Vibration	IEC60068-2-6 (Test Fc) 5-9Hz:3.5mm amplitude, 9-150Hz 1.0G 10 sweep cycles per axis on each of 3 mutually perpendicular axes.
Shock	IEC60068-2-27 (Test Ea) 15G peak, 11ms duration, 3 shocks in each direction per axis, on 3 mutually perpendicular axes.
Noise Immunity	<EN61131-2> EN61000-4-2 (ESD) EN61000-4-3 (RFI) EN61000-4-4 (FTB) EN61000-4-5 (Surge) EN61000-4-6 (Conducted) EN61000-4-8 (Power frequency magnetic field immunity) <Local Test> Impulse Immunity : 1000V @ 1uS pulse
Emissions	EN55011 Class A (Radiated RF emission)
Agency Approvals	UL61010 (File No. E157382, E316037); CE (EN61131-2); CUL Canadian C22.2
Other	RoHS 2011/65/EU Amendment (EU)2015/863

C2-DCM – Data Communication Module

The CLICK PLUS serial communications module provides two RS-232/RS-485 ports. This configuration allows Modbus master/slave networking or connection to serial devices using ASCII communications protocol.

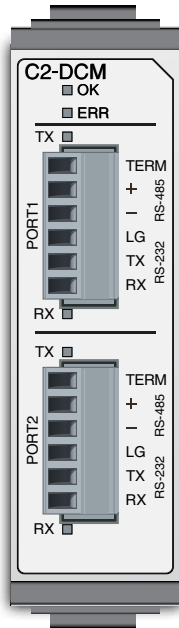

Port Specifications	
Number of Ports	2
Port Types	RS-232, RS-485 (2-wire)
Supported Protocols	Modbus RTU, ASCII (user-defined)
Communications Parameters	<ul style="list-style-type: none"> Baud rate: 2400, 4800, 9600, 19200, 38400, 57600, 115.2k bps Data bit: 7 bits, 8 bits Parity: None, Odd, Even Stop bit: 1 bit, 2 bits Flow Control: None
RS-485 Terminating Resistor	120Ω, Internal
Status Indicator LEDs	OK, ERR, TX (per port), RX (per port)

Modbus Specifications	
Station Number Range	1-247
Timeout Setting	100ms, 200ms, 500ms, 1s, 2s, 5s, 10s, 20s, 30s
Character Timeout	2-1000ms
Response Delay Time	0-5000ms
Modbus Function Codes	Master/Slave: 01 - Read Coil Status 02 - Read Input Bits 03 - Read Holding Register 04 - Read Input Register 05 - Write Single Coil 06 - Write Single Register 15 - Write Multiple Coils 16 - Write Multiple Registers

General Specifications	
Current Consumption at 24VDC	60mA max
Weight	41g

Terminal Block Specifications	
Connector Type	Pluggable Terminal Block
Number of Pins	6 (x2 terminal blocks)
Pitch	3.50 mm
Wire Size Range	22-26 AWG
Stripping Length	7.0 mm
Wire Specification	Lead-free, heat resistant, polyvinyl chloride insulated copper wire, rated over 80°C
Screw Thread	M2.0
Tightening Torque	1.7 lb-inch [0.19 N·m]
Recommended Cable	Shielded cable (AutomationDirect Q8105-1 or Q8302-1 recommended)

Wiring Diagrams

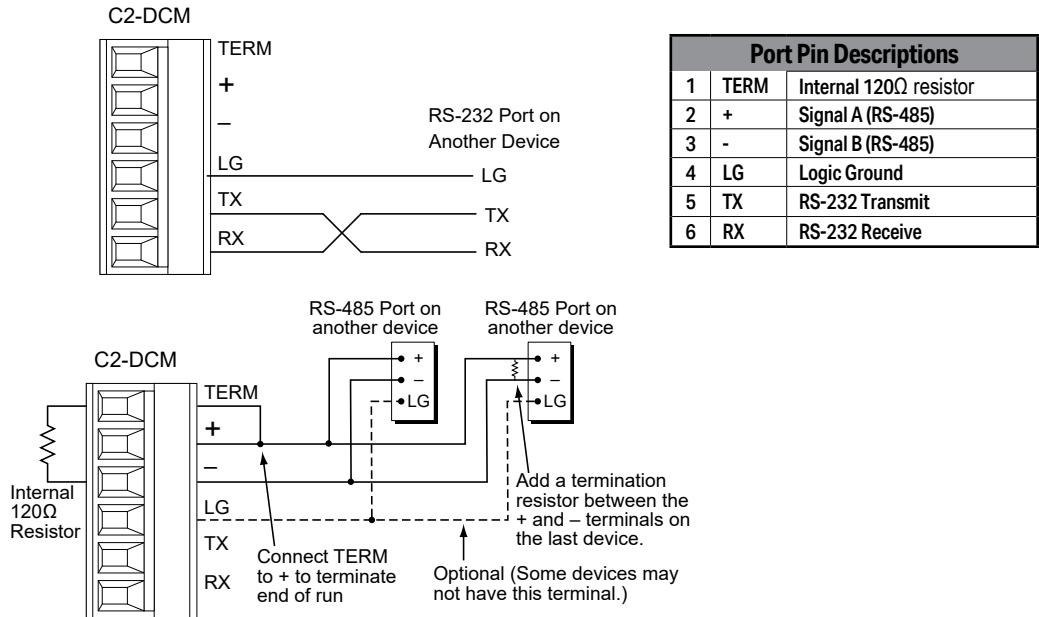

LED Indicators

OK LED (Green)	
On	Operating Normally
Blink	Updating Now
Off	No Power or Program Stopped

ERROR LED (Red)	
Blink	Port Communication Error
Off	No Error

TX & RX LED (Green)	
On	Com Port Data Active
Off	No Communication

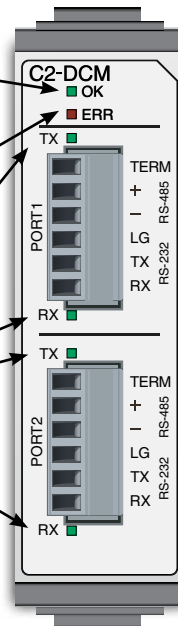

C2-NRED – Node-RED Intelligent Module

The CLICK PLUS Node-RED module provides a Node-RED server that runs independently of the CPU program. The Node-RED project can read and write CLICK registers as well as access external resources.

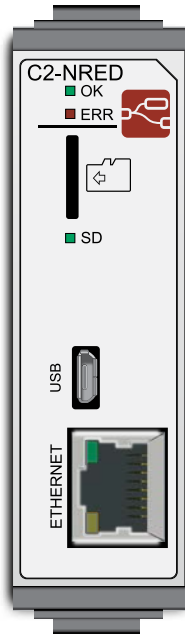

USB Programming Port Specifications	
Communications Ratings	USB 2.0 High Speed (480Mbps)
Connector	Micro USB Type B
5V Bus Power	No
Communication Method	Virtual Ethernet over USB
Default Settings	IP address acquisition by APIPA. PC-side IP address automatically assigned by DHCP server function.
Recommended Cable	AutomationDirect p/n USB-CBL-AMICB6
USB Cable Length	Max 3m
Protocols	Node-RED TCP/UDP DHCP Client



Micro SD Card Slot Specifications	
Card Type	microSDHC
Format	FAT32
Capacity	32GB maximum
Recommended Card	MSD-SLC16G



Ethernet Port Specifications	
Communications Ratings	10/100 Base-T
Cable Specifications	Category 5
Auto MDI/MDIX	Yes
Connector	RJ45
IP Address	DHCP (default), fixed address, manual address
Protocols	Node-RED TCP/UDP SNTP Client DHCP Client DNS

General Specifications	
24VDC Bus Power Required	Max 3W*
Weight	41g

* Due to the large current consumption of NRED, it does not support USB low power mode with C2-CPU. Requires 24V power supply.

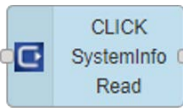
Node-RED Node Interaction with CLICK PLUS PLC

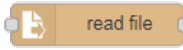
Node-RED Nodes that Share Data with CLICK	
	This requires an array as input and writes a set number of values to the address specified.
	Accepts a starting memory address and a length. Populates an array starting with the first address e.g. X201, Len 4 will return an array [X201, X202, X203, X204].
	The same behaviors as CLICK Read, except this provides read-only access to SC bits and SD data registers. It will output an array of values. A register like RTC Day will output a simple Array containing a one-digit integer, while MAC ID will output an array with 6-3 digit integers representing the macID.

Node-RED Nodes that Interact with CLICK	
	This node writes a file to the C2-NRED filesystem. It has 1.5 GB available space (including your program). The file system has been locked down to prevent access or modification of any system files, but the following directory is available for user data: /usr/local/nred-work/ In addition, you may write files to the SD Card if one has been inserted into the SD Card slot. The path to the SD card is: /run/media/mmcbk0p1/
	This node reads the data written to a file created by the write file node.
	This node will initiate a flow when data is written to a file by the write file node. It outputs the name of the file that was modified.

LED Indicators

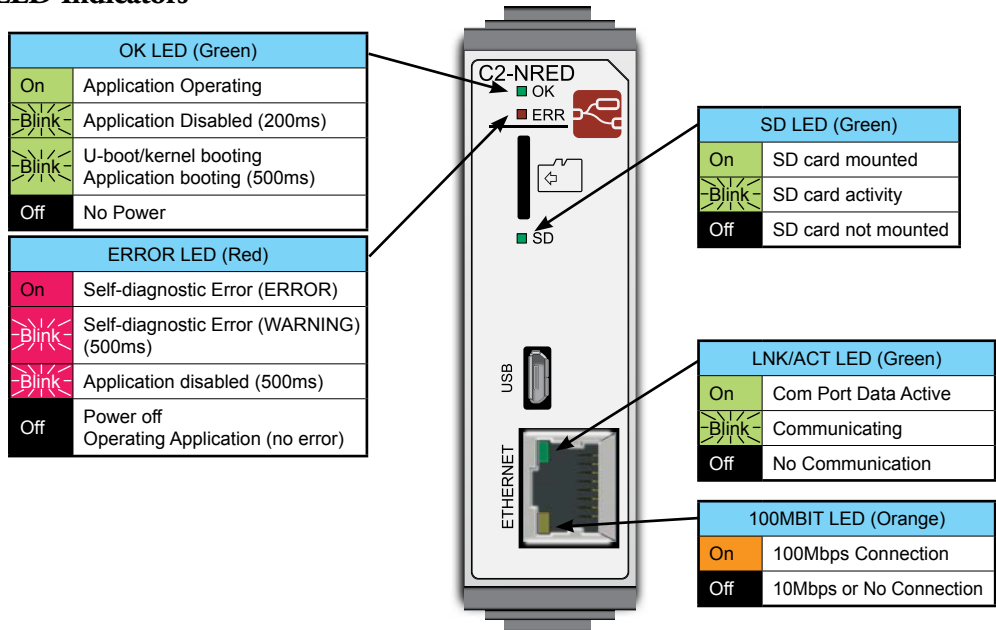

C2-OPCUA – OPC UA Intelligent Module

The C2-OPCUA is a CLICK PLUS PLC Slot Module that is an OPC UA server. It can securely read all of the data registers in your CLICK PLC and provide access to those registers using the OPC UA communication standard.

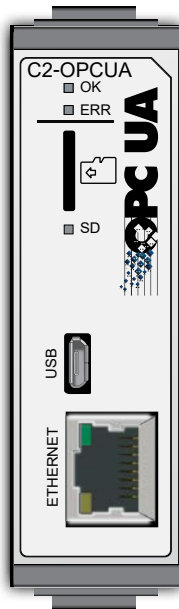

USB Programming Port Specifications	
Communications Ratings	USB 2.0 High Speed (480Mbps)
Connector	Micro USB Type B
5V Bus Power	No
Communication Method	Virtual Ethernet over USB
Default Settings	IP address acquisition by APIPA. PC-side IP address automatically assigned by DHCP server function.
Recommended Cable	AutomationDirect p/n USB-CBL-AMICB6
USB Cable Length	Max 3m
Protocols	OPC UA Server

Micro SD Card Slot Specifications	
Card Type	microSDHC
Format	FAT32
Capacity	32GB maximum
Recommended Card	<u>MSD-SLC16G</u>

Ethernet Port Specifications	
Communications Ratings	10/100 Base-T
Cable Specifications	Category 5
Auto MDI/MDIX	Yes
Connector	RJ45
IP Address	Fixed address, manual address
Protocols	OPC UA Server SNTP Client DNS

General Specifications	
24VDC Bus Power Required	Max 3W*
Weight	41g

* Due to the large current consumption of NRED, it does not support USB low power mode with C2-CPU. Requires 24V power supply.

OPC UA Specifications		
OPC UA Version	1.04	
Type	Server	
Profile	Embedded 2017 UA Server Profile	
Number of Client Connections	5 maximum	
Number of Data Items	1024 maximum	
Total Data Size	4096 bytes maximum	
Security	Sign, Sign and Encrypt, None	
Authentication	User and Password, Anonymous	
Historization	Not supported	
Alarms and Conditions	Not supported	
UDP Pub/Sub	Not supported	
Data Access	Can access all bit and data memory of CLICK PLUS	
	Read	X, T, CT, XD, some SC, some SD
	Read/Write	Y, C, DS, DD, DH, DF, YD, TD, CTD, TXT, some SC, some SD

LED Indicators

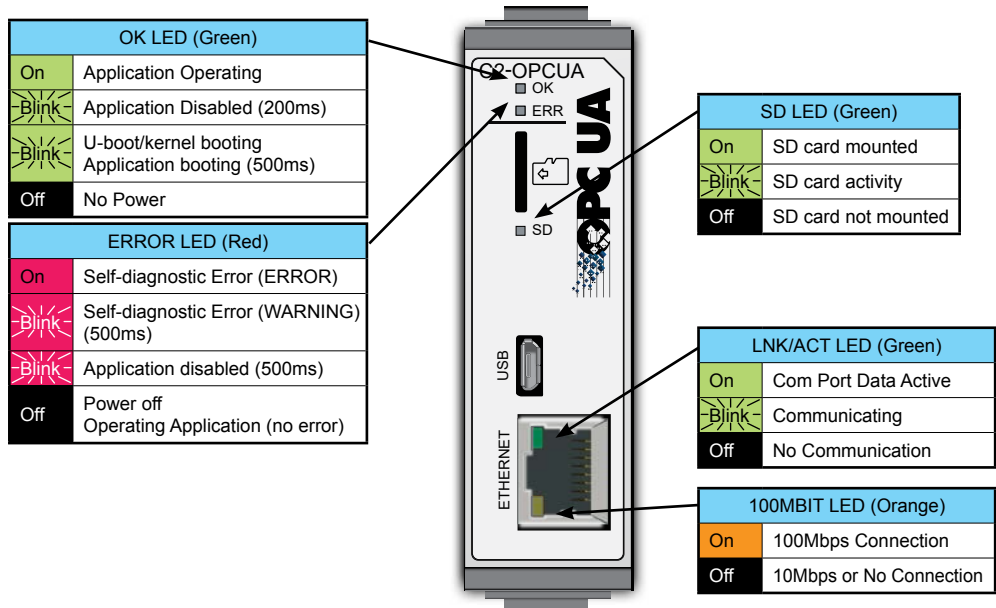

Stackable I/O Module Specifications

I/O Terminal Block Specifications for CPUs and I/O Modules



11-Pin Terminal Block,
C0-8TB

11-pin Terminal Block Specifications	
Connector Type	Pluggable Terminal Block
Number of Pins	11 pt
Pitch	3.50 mm
Wire Range	28–16 AWG
Wire Strip Length	7mm
Screw Size	M2.0
Screw Torque	2.0 to 2.2 lb-inch
AutomationDirect Part Number	C0-8TB

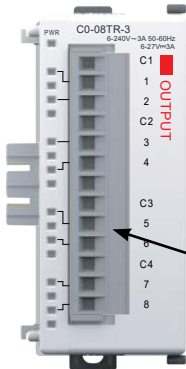

13-Pin Terminal Block,
C0-8TB-1

13-pin Terminal Block Specifications	
Connector Type	Pluggable Terminal Block
Number of Pins	13 pt
Pitch	5.08 mm
Wire Range	12–20 AWG
Wire Strip Length	7.0–8.0 mm
Screw Size	M2.5
Screw Torque	4.51 lb-inch
AutomationDirect Part Number	C0-8TB-1

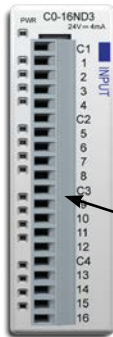

20-Pin Terminal Block,
C0-16TB

20-pin Terminal Block Specifications	
Connector Type	Pluggable Terminal Block
Number of Pins	20 pt
Pitch	3.50 mm
Wire Range	28–16 AWG
Wire Strip Length	7mm
Screw Size	M2.0
Screw Torque	2.0 to 2.2 lb-inch
AutomationDirect Part Number	C0-16TB

LED Indicators

All CLICK Discrete I/O modules have an LED Power Indicator, PWR. When this LED is on, the I/O module is receiving 24VDC through the backplane connector. The input modules have green LEDs and the output modules have red LEDs respectively as the status indicator. When the LED is on, the I/O point is on.

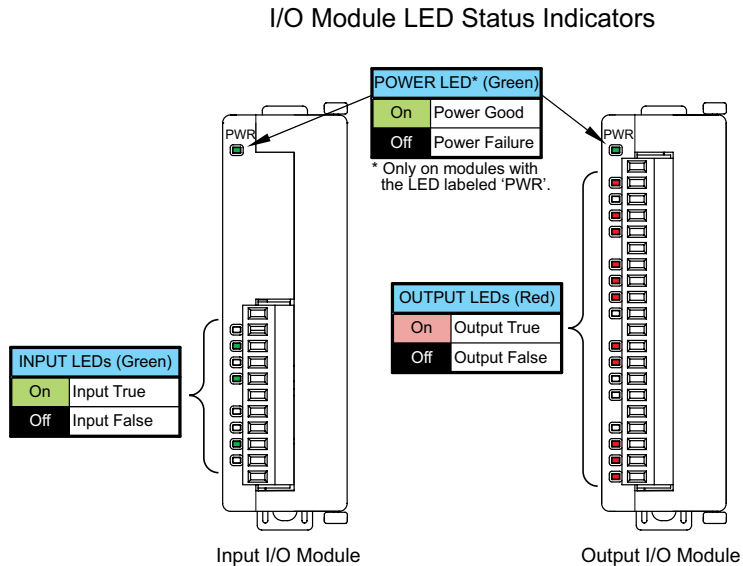

C0-08SIM – 8-Point Toggle Switch Input Module

8-point toggle switch input module provides for simple simulation of system discrete inputs.



Input Specifications	
Inputs per Module	8 Toggle Switches
OFF to ON Response	Max 140ms, Typ 90ms
ON to OFF Response	Max 110ms, Typ 60ms
Status Indicators	Logic Side (8 points, green LED) Power Indicator (green LED)
Bus Power Required	Max. 50mA (All points ON)
Weight	2.9 oz (84g)



CAUTION

The C0-08SIM unit toggle switch can get hot when mounted in hot environment. Wear heat-resistant gloves before use, as it may cause burns.

C0-04POT – 4-Point Potentiometer Input Module

4-point potentiometer input module with 12-bit resolution provides for simple simulation of system analog inputs.



Input Specifications	
Inputs per Module	4 Potentiometers
Resolution	12-bit
Total Rotation Angle	280° ±10°
Conversion Time	25ms
Input Stability	±2LSB maximum
Full-Scale Calibration Error	±2% maximum
Offset Calibration Error	±13LSB maximum
Accuracy vs Temperature Error	±100ppm/°C maximum
Instantaneous Deviation During Noise Test	±20% of full scale maximum
Status Indicators	Logic Side (8 points, green LED) Power Indicator (green LED)
Bus Power Required	30mA maximum
Weight	2.9 oz [84g]

C0-08ND3 – 8-Point Sink/Source DC Input Module

8-point 12–24 VDC current sinking or sourcing input module, 2 commons, isolated, removable terminal block included.

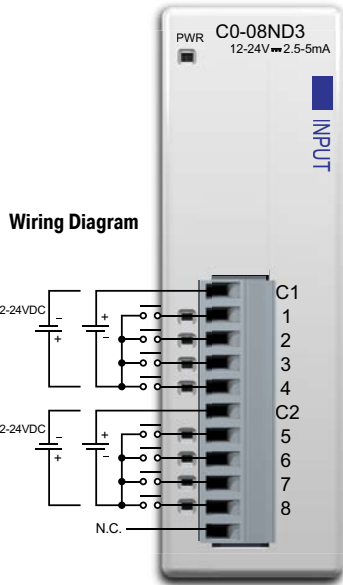

N.C. = Not Connected

Input Specifications	
Inputs per Module	8 (Sink/Source)
Operating Voltage Range	12–24 VDC
Input Voltage Range	10.8 – 26.4 VDC
Input Current	Typ 5mA @ 24VDC
Maximum Input Current	7mA @ 26.4 VDC
Input Impedance	4.7 kΩ @ 24VDC
ON Voltage Level	> 8.0 VDC
OFF Voltage Level	< 3.0 VDC
Minimum ON Current	1.4 mA
Maximum OFF Current	0.5 mA
OFF to ON Response	Max 3.5 ms, Typ 2ms
ON to OFF Response	Max 4 ms, Typ 2.5 ms
Status Indicators	Logic Side (8 points, green LED) Power Indicator (green LED)
Commons	2 (4 points/common) Isolated
Bus Power Required (24VDC)	Max. 30mA (All Inputs On)
Terminal Block Replacement	AutomationDirect p/n C0-8TB
Weight	2.8 oz (80g)

Equivalent Input Circuit

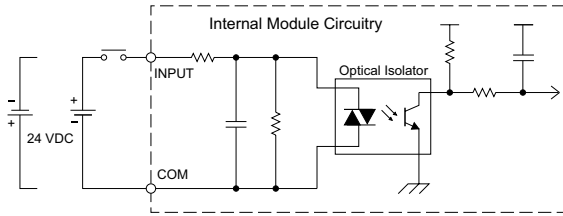

Input Module Temperature Derating Chart

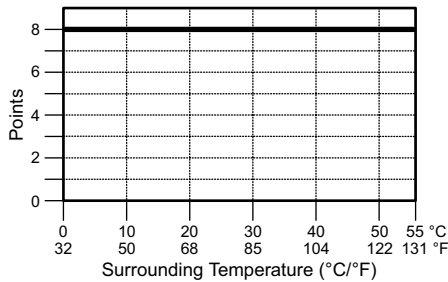

ZIPLink Pre-Wired PLC Connection Cables and Modules for CLICK PLC



- 11-pin connector cable
- ZL-C0-CBL11 (0.5 m length)
- ZL-C0-CBL11-1 (1.0 m length)
- ZL-C0-CBL11-2 (2.0 m length)



- ZL-RTB20
- 20-pin feed-through connector module

Chapter 2: Specifications

C0-08ND3-1 – 8-Point Sink/Source DC Input Module

8-point 3.3–5 VDC current sinking or sourcing input module, 2 commons, isolated, removable terminal block included.

Wiring Diagram

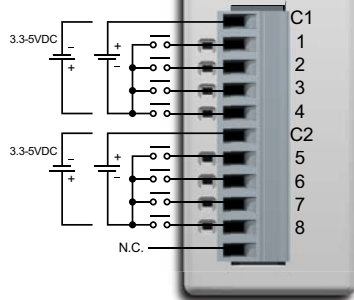

N.C. = Not Connected

Input Specifications	
Inputs per Module	8 (Sink/Source)
Operating Voltage Range	3.3–5 VDC
Input Voltage Range	2.8 – 5.5 VDC
Input Current	Typ 5.5 mA @ 5 VDC
Maximum Input Current	7.5 mA @ 5.5 VDC
Input Impedance	680 Ω
ON Voltage Level	> 2.2 VDC
OFF Voltage Level	< 0.8 VDC
Minimum ON Current	1.4 mA
Maximum OFF Current	0.2 mA
OFF to ON Response	Max. 3ms Typ. 1.6 ms
ON to OFF Response	Max. 4ms Typ. 2.3 ms
Status Indicators	Logic Side (8 points, green LED) Power Indicator (green LED)
Commons	2 (4 points/common) Isolated
Bus Power Required (24VDC)	Max. 30mA (All Inputs On)
Terminal Block Replacement	AutomationDirect p/n C0-8TB
Weight	2.8 oz (80g)

Equivalent Input Circuit

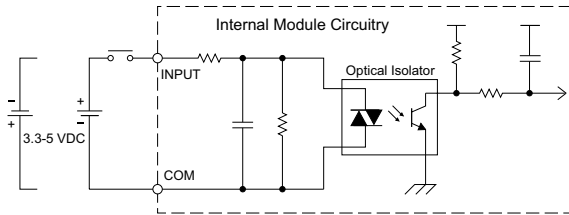

Input Module Temperature Derating Chart

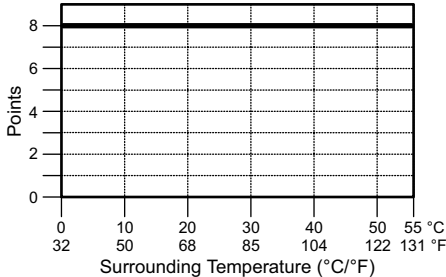

ZIPLink Pre-Wired PLC Connection Cables and Modules for CLICK PLC



- 11-pin connector cable
- ZL-C0-CBL11 (0.5 m length)
- ZL-C0-CBL11-1 (1.0 m length)
- ZL-C0-CBL11-2 (2.0 m length)

ZL-RTB20
20-pin feed-through
connector module



C0-16ND3 – 16-Point Sink/Source DC Input Module

16-point 24VDC current sinking or sourcing input module, 4 commons, isolated, removable terminal block included.

Wiring Diagram

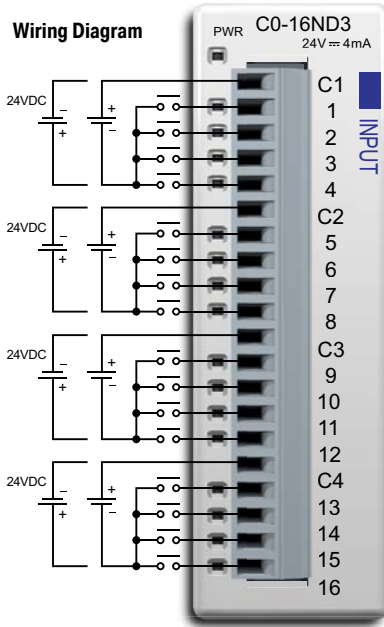

Input Specifications	
Inputs per Module	16 (Sink/Source)
Operating Voltage Range	24VDC
Input Voltage Range	21.6 – 26.4 VDC
Input Current	Typ 4.0 mA @ 24VDC
Maximum Input Current	5.0 mA @ 26.4 VDC
Input Impedance	6.8 kΩ @ 24VDC
ON Voltage Level	> 19VDC
OFF Voltage Level	< 7VDC
Minimum ON Current	3.5 mA
Maximum OFF Current	0.5 mA
OFF to ON Response	Max. 10ms Typ 2ms
ON to OFF Response	Max. 10ms Typ 3ms
Status Indicators	Logic Side (16 points, green LED) Power Indicator (green LED)
Commons	4 (4 points/common) Isolated
Bus Power Required (24VDC)	Max. 40 mA (All Inputs On)
Terminal Block Replacement	AutomationDirect p/n C0-16TB
Weight	3.2 oz (90g)

Equivalent Input Circuit

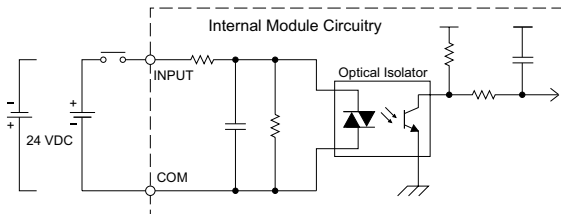

ZIPLink Pre-Wired PLC Connection Cables and Modules for CLICK PLC

- 20-pin connector cable
- ZL-C0-CBL20 (0.5 m length)
- ZL-C0-CBL20-1 (1.0 m length)
- ZL-C0-CBL20-2 (2.0 m length)

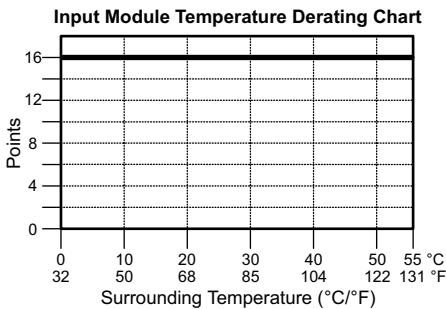

ZL-RTB20 20-pin feed-through connector module



ZL-LTB16-24-1 sensor input module

Chapter 2: Specifications

C0-08NE3 – 8-Point Sink/Source AC/DC Input Module

8-point 24VAC / 24VDC current sinking or sourcing input module, 2 commons, 4 points per common, removable terminal block included.

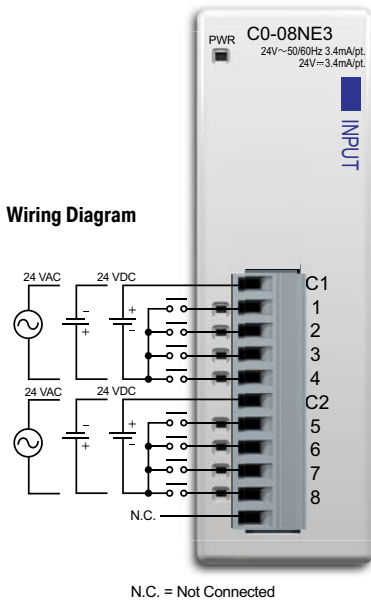

Input Specifications	
Inputs per Module	8 (Sink/Source)
Operating Voltage Range	24 VAC/VDC
Input Voltage Range	20.4 – 27.6 VAC/VDC
Peak Voltage	27.6 VAC/VDC
AC Frequency	47–63 Hz
Input Current	Typ 3.4 mA @ 24 VAC/VDC
Maximum Input Current	5.0 mA @ 27.6 VAC/VDC
Input Impedance	6.8 KΩ @ 24 VAC/VDC
ON Voltage Level	> 18.0 VAC/VDC
OFF Voltage Level	< 4.0 VAC/VDC
Minimum ON Current	2.5 mA
Maximum OFF Current	0.5 mA
OFF to ON Response	5–40 ms
ON to OFF Response	10–50 ms
Status Indicators	Logic Side (8 points, green LED) Power Indicator (green LED)
Commons	2 (4 points/common) Isolated
Bus Power Required (24VDC)	Max. 30mA (All Inputs On)
Terminal Block Replacement	AutomationDirect p/n C0-8TB
Weight	2.9 oz (82g)



NOTE: When using this module you must also use CLICK programming software version V1.20 or later.

Equivalent Input Circuit

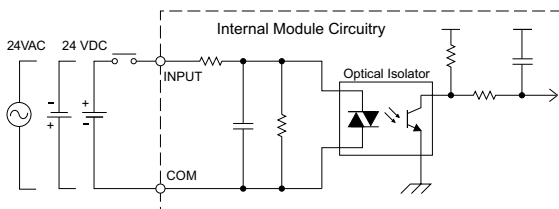

Input Module Temperature Derating Chart

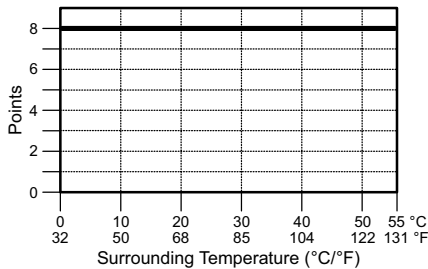

ZIPLink Pre-Wired PLC Connection Cables and Modules for CLICK PLC

11-pin connector cable
 ZL-C0-CBL11 (0.5 m length)
 ZL-C0-CBL11-1 (1.0 m length)
 ZL-C0-CBL11-2 (2.0 m length)



ZL-RTB20
 20-pin feed-through connector module



C0-16NE3 – 16-Point Sink/Source AC/DC Input Module

16-point 24VAC / 24VDC current sinking or sourcing input module, 4 commons, 4 points per common, removable terminal block included.

Wiring Diagram

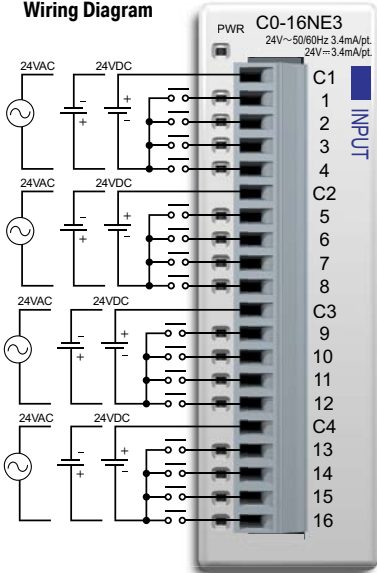

Input Specifications

Inputs per Module	16 (Sink/Source)
Operating Voltage Range	24 VAC/VDC
Input Voltage Range	20.4 – 27.6 VAC/VDC
Peak Voltage	27.6 VAC/VDC
AC Frequency	47-63 Hz
Input Current	Typ 3.4 mA @ 24 VAC/VDC
Maximum Input Current	5.0 mA @ 27.6 VAC/VDC
Input Impedance	6.8 kΩ @ 24 VAC/VDC
ON Voltage Level	> 18.0 VAC/VDC
OFF Voltage Level	< 4.0 VAC/VDC
Minimum ON Current	2.5 mA
Maximum OFF Current	0.5 mA
OFF to ON Response	5–40 ms
ON to OFF Response	10–50 ms
Status Indicators	Logic Side (16 points, green LED) Power Indicator (green LED)
Commons	4 (4 points/common) Isolated
Bus Power Required (24VDC)	Max. 40mA (All Inputs On)
Terminal Block Replacement	AutomationDirect p/n C0-16TB
Weight	3.2 oz (90g)



NOTE: When using this module you must also use CLICK programming software version V1.20 or later.

ZIPLink Pre-Wired PLC Connection Cables and Modules for CLICK PLC

Equivalent Input Circuit

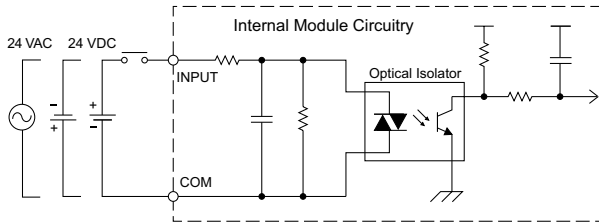

20-pin connector cable
 ZL-C0-CBL20 (0.5 m length)
 ZL-C0-CBL20-1 (1.0 m length)
 ZL-C0-CBL20-2 (2.0 m length)



Input Module Temperature Derating Chart

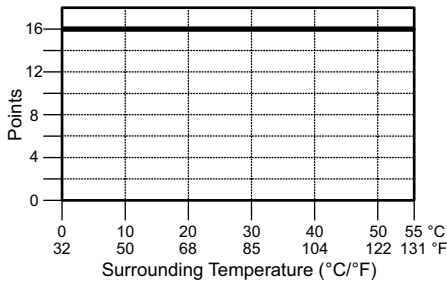

ZL-RTB20 20-pin feed-through connector module



ZL-LTB16-24-1 sensor input module

Chapter 2: Specifications

C0-08NA – 8-Point AC Input Module

8-point 100–120 VAC input module, 2 commons, isolated, removable terminal block included.

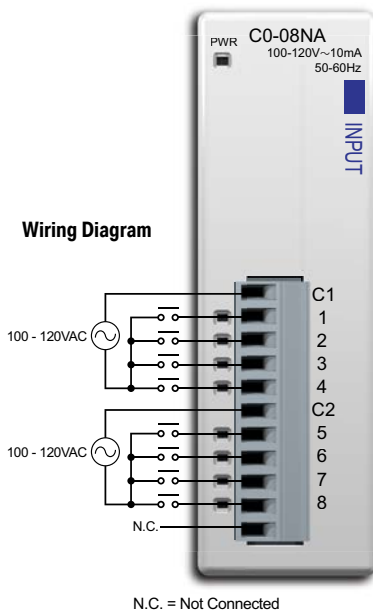

Input Specifications	
Inputs per Module	8
Operating Voltage Range	100–120 VAC
Input Voltage Range	80–144 VAC
AC Frequency	47–63 Hz
Input Current	Typ 8.5 mA @ 100VAC (50Hz) Typ 10mA @ 100VAC (60Hz)
Maximum Input Current	16mA @ 144VAC
Input Impedance	15kΩ (50 Hz), 12kΩ (60Hz)
ON Voltage Level	> 70VAC
OFF Voltage Level	< 20VAC
Minimum ON Current	5mA
Maximum OFF Current	2mA
OFF to ON Response	< 40ms
ON to OFF Response	< 40ms
Status Indicators	Logic Side (8 points, green LED) Power Indicator (green LED)
Commons	2 (4 points/common) Isolated
Bus Power Required (24VDC)	Max. 30mA (All Inputs On)
Terminal Block Replacement	AutomationDirect p/n C0-8TB
Weight	2.8 oz (80g)

Equivalent Input Circuit

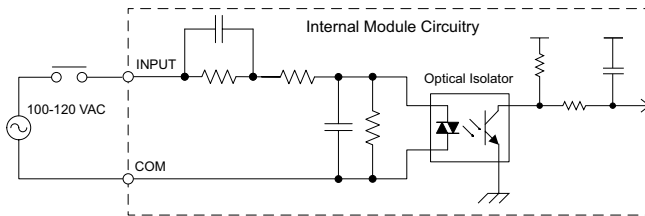

ZLink Pre-Wired PLC Connection Cables and Modules for CLICK PLC

11-pin connector cable
 ZL-C0-CBL11 (0.5 m length)
 ZL-C0-CBL11-1 (1.0 m length)
 ZL-C0-CBL11-2 (2.0 m length)



Input Module Temperature Derating Chart

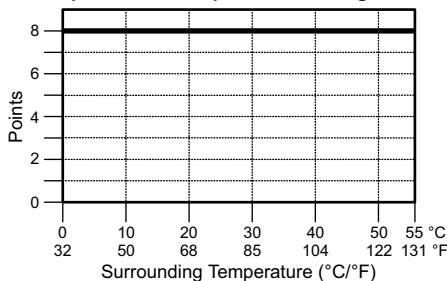

ZL-RTB20
 20-pin feed-through connector module



C0-08TD1 – 8-Point Sinking DC Output Module

8-point 3.3–27 VDC current sinking output module, 2 commons, 0.3 A/pt, removable terminal block included.

Wiring Diagram

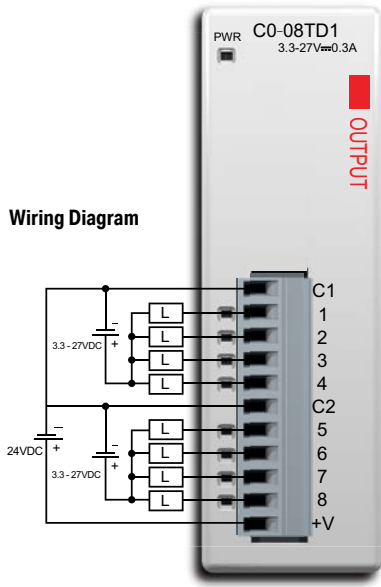

Output Specifications	
Outputs per Module	8 (Sink)
Operating Voltage Range	3.3–27 VDC
Output Voltage Range	2.8–30 VDC
Maximum Output Current	0.3 A/point , 1.2 A/common
Minimum Output Current	0.5 mA
Maximum Leakage Current	0.1 mA @ 30.0 VDC
On Voltage Drop	1.5 VDC @ 0.3 A
Maximum Inrush Current	1A for 10ms
OFF to ON Response	< 0.5 ms
ON to OFF Response	< 0.5 ms
Status Indicators	Logic Side (8 points, red LED) Power Indicator (green LED)
Commons	2 (4 points/common)
External DC Power Required	21.6 – 26.4 VDC Max 15mA (All Outputs On)
Bus Power Required (24VDC)	Max. 50mA (All Outputs On)
Terminal Block Replacement	AutomationDirect p/n C0-8TB
Weight	2.8 oz (80g)

Equivalent Output Circuit

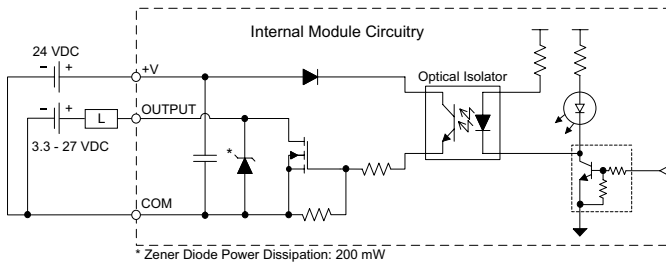

Z/PLink Pre-Wired PLC Connection Cables and Modules for CLICK PLC

- 11-pin connector cable
- ZL-C0-CBL11 (0.5 m length)
- ZL-C0-CBL11-1 (1.0 m length)
- ZL-C0-CBL11-2 (2.0 m length)



Output Module Temperature Derating Chart

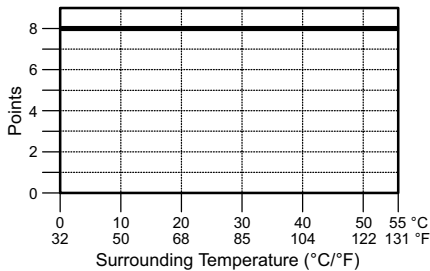

ZL-RTB20
20-pin feed-through
connector module



Chapter 2: Specifications

C0-08TD2 – 8-Point Sourcing DC Output Module

8-point 12–24VDC current sourcing output module, 1 common, 0.3 A/pt, removable terminal block included.

Wiring Diagram

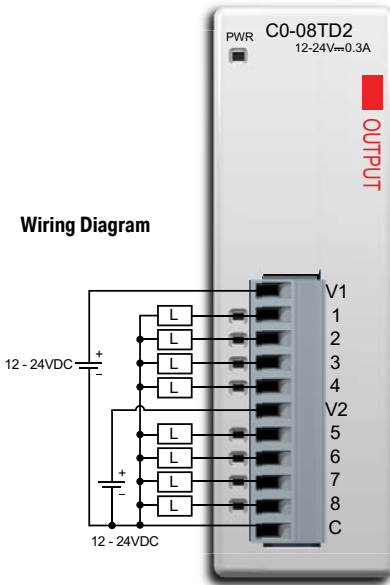

Output Specifications	
Outputs per Module	8 (Source)
Operating Voltage Range	12–24VDC
Output Voltage Range	9.6–30 VDC
Maximum Output Current	0.3 A/point , 1.2 A/common
Minimum Output Current	0.5 mA
Maximum Leakage Current	0.1 mA @ 30.0 VDC
On Voltage Drop	1.5 VDC @ 0.3 A
Maximum Inrush Current	1A for 10ms
OFF to ON Response	< 1ms
ON to OFF Response	< 1ms
Status Indicators	Logic Side (8 points, red LED) Power Indicator (green LED)
Commons	1 (8 points/common)
Bus Power Required (24VDC)	Max. 50mA (All Outputs On)
Terminal Block Replacement	AutomationDirect p/n C0-8TB
Weight	2.8 oz (80g)

Equivalent Output Circuit

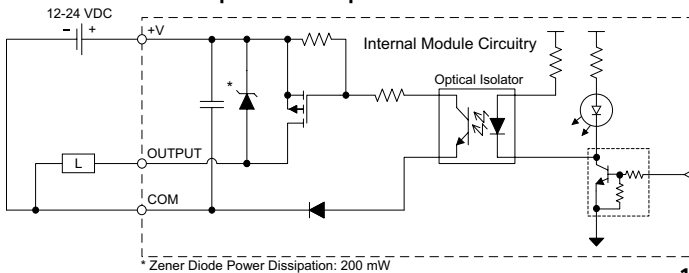

Z/PLink Pre-Wired PLC Connection Cables and Modules for CLICK PLC



11-pin connector cable
 ZL-C0-CBL11 (0.5 m length)
 ZL-C0-CBL11-1 (1.0 m length)
 ZL-C0-CBL11-2 (2.0 m length)

Output Module Temperature Derating Chart

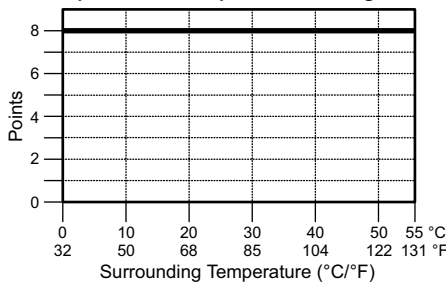

ZL-RTB20
 20-pin feed-through connector module



C0-16TD1 – 16-Point Sinking DC Output Module

16-point 5–27 VDC current sinking output module, 2 commons, isolated, 0.1 A/pt, removable terminal block included.

Wiring Diagram

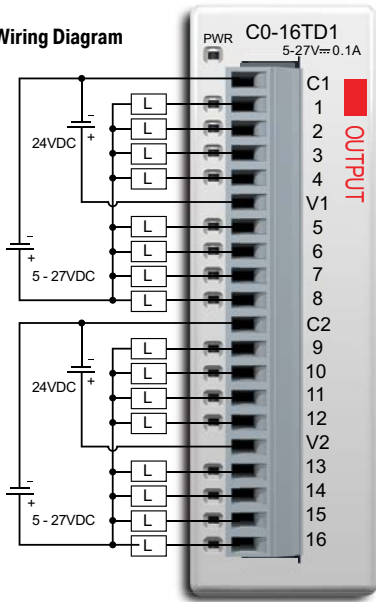

Output Specifications

Outputs per Module	16 (Sink)
Operating Voltage Range	5–27 VDC
Output Voltage Range	4–30 VDC
Maximum Output Current	0.1 A/point, 0.8 A/common
Minimum Output Current	0.2 mA
Maximum Leakage Current	0.1 mA @ 30.0 VDC
On Voltage Drop	0.5 VDC @ 0.1 A
Maximum Inrush Current	150mA for 10ms
OFF to ON Response	< 0.5 ms
ON to OFF Response	< 0.5 ms
Status Indicators	Logic Side (16 points, red LED) Power Indicator (green LED)
Commons	2 (8 Points/common) Isolated
External DC Power Required	21.6 – 26.4 VDC Max 100mA (All Outputs On)
Bus Power Required (24VDC)	Max. 80mA (All Outputs On)
Terminal Block Replacement	AutomationDirect p/n C0-16TB
Weight	3.2 oz (90g)

ZIPLink Pre-Wired PLC Connection
Cables and Modules for CLICK PLC

Equivalent Output Circuit

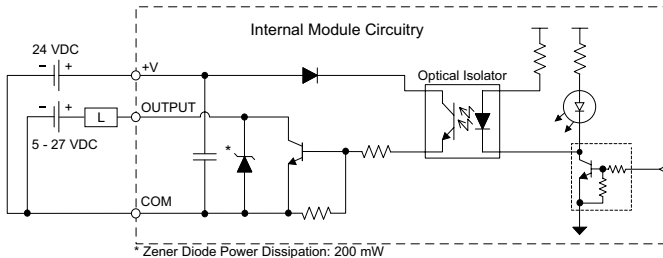

20-pin connector cable
ZL-C0-CBL20 (0.5 m length)
ZL-C0-CBL20-1 (1.0 m length)
ZL-C0-CBL20-2 (2.0 m length)

Output Module Temperature Derating Chart

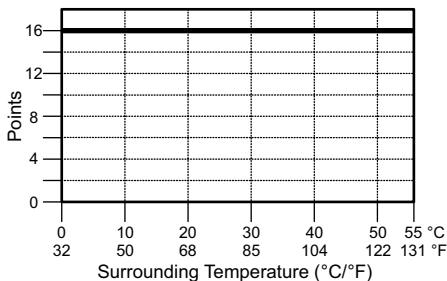

ZL-RTB20 20-pin
feed-through
connector module



ZL-RFU20 fuse
module



ZL-RRL16-24-1 relay module
Note: 10A/Point (DC)
8A/Point (AC)
(Replaceable relays)



C0-16TD2 – 16-Point Sourcing Output Module

16-point 12–24 VDC current sourcing output module, 2 commons, isolated, 0.1 A/pt, removable terminal block included.

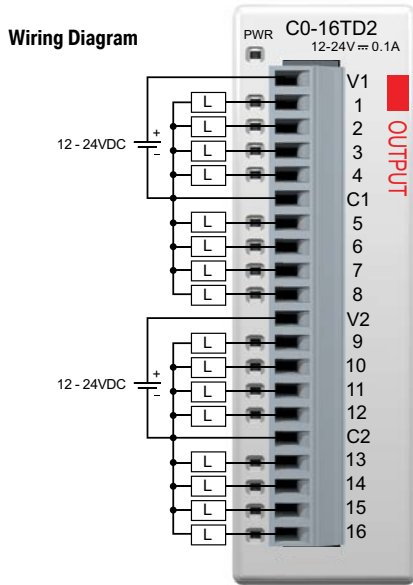

Output Specifications	
Outputs per Module	16 (Source)
Operating Voltage Range	12–24VDC
Output Voltage Range	9.6 – 30.0 VDC
Maximum Output Current	0.1 A/point, 0.8 A/common
Minimum Output Current	0.2 mA
Maximum Leakage Current	0.1 mA @ 30.0 VDC
On Voltage Drop	0.6 VDC @ 0.1 A
Maximum Inrush Current	150mA for 10ms
OFF to ON Response	< 0.5 ms
ON to OFF Response	< 0.5 ms
Status Indicators	Logic Side (16 points, red LED) Power Indicator (green LED)
Commons	2 (8 points/common) Isolated
Bus Power Required (24VDC)	Max. 80mA (All Outputs On)
Terminal Block Replacement	AutomationDirect p/n C0-16TB
Weight	3.2 oz (90g)

Equivalent Output Circuit

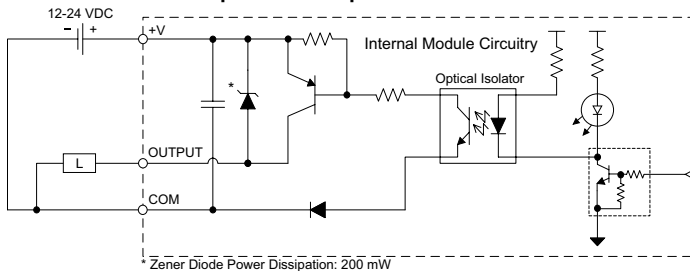

Z/Link Pre-Wired PLC Connection Cables and Modules for CLICK PLC



- 20-pin connector cable
- ZL-C0-CBL20 (0.5 m length)
- ZL-C0-CBL20-1 (1.0 m length)
- ZL-C0-CBL20-2 (2.0 m length)

Output Module Temperature Derating Chart

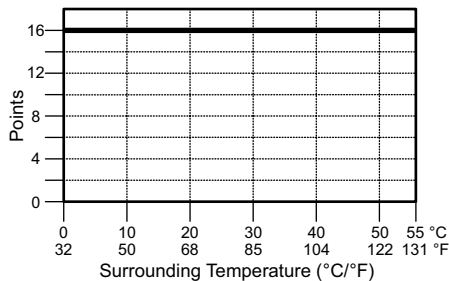

C0-08TA – 8-Point AC Output Module

8-point 17-240 VAC triac output module, 2 commons, isolated, 0.3 A/pt, removable terminal block included.

Wiring Diagram

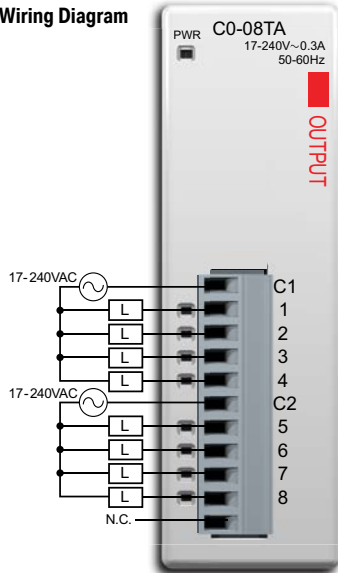

N.C. = Not Connected

Output Specifications	
Outputs per Module	8
Operating Voltage Range	17-240 VAC
Output Voltage Range	13.5-288 VAC
AC Frequency	47-63 Hz
Maximum Output Current	0.3 A/point, 1.2 A/common
Minimum Load	10mA
Maximum Leakage Current	4mA @ 288 VAC
On Voltage Drop	1.5 VAC @ > 0.1 A 3.0 VAC @ < 0.1 A
Maximum Inrush Current	10A for 10ms
OFF to ON Response	1ms
ON to OFF Response	1ms + 1/2 cycle
Status Indicators	Logic Side (8 points, red LED) Power Indicator (green LED)
Commons	2 (4 points/common) Isolated
Bus Power Required (24VDC)	Max. 80mA (All Outputs On)
Protection Circuit	Not built into the module - Install protection elements such as external fuse.
Terminal Block Replacement	AutomationDirect p/n C0-8TB
Weight	3.5 oz (100g)

Equivalent Output Circuit

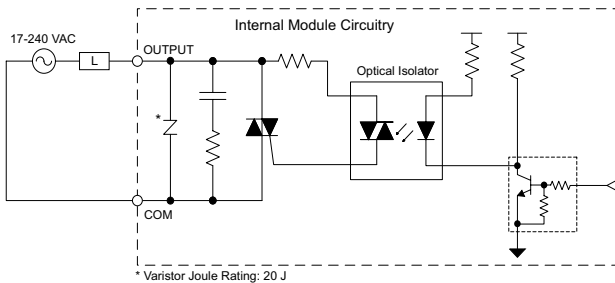

Z/PLink Pre-Wired PLC Connection Cables and Modules for CLICK PLC

- 11-pin connector cable
- ZL-C0-CBL11 (0.5 m length)
- ZL-C0-CBL11-1 (1.0 m length)
- ZL-C0-CBL11-2 (2.0 m length)



Output Temperature Derating Chart

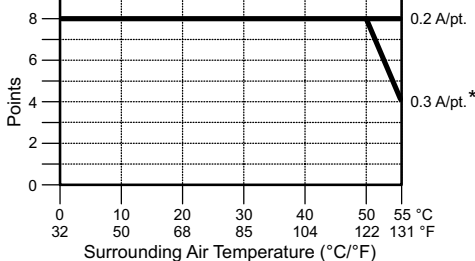

* Use every other output.

ZL-RTB20
20-pin feed-through connector module



Chapter 2: Specifications

C0-04TRS – 4-Point Relay Output Module

4-point 6–240 VAC / 6–27VDC Isolated relay output module, 4 Form C (SPDT) relays, 4 isolated commons, 7 A/point, removable terminal block included.

Wiring Diagram

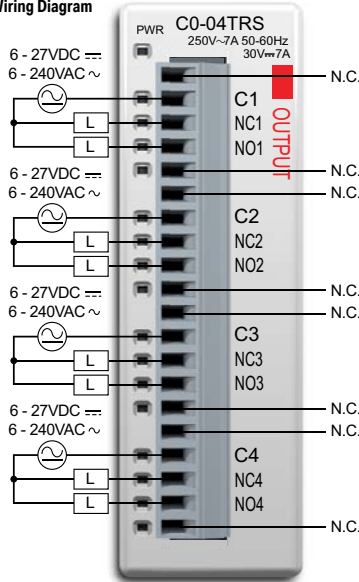

N.C. = Not Connected

Output Specifications	
Outputs per Module	4
Operating Voltage Range	6–27 VDC / 6–240 VAC
Output Voltage Range	5–30 VDC / 5–264 VAC
Output Type	Relay, form C (SPDT)
AC Frequency	47–63 Hz
Maximum Current	7A / point, 7A / common
Minimum Load Current	100mA @ 5VDC
Maximum Leakage Current	0.1 mA @ 264VAC
Maximum Inrush Current	12A
OFF to ON Response	< 15ms
ON to OFF Response	< 15ms
Status Indicators	Logic Side (4 points, red LED) Power Indicator (green LED)
Commons	4 (1 point/common) Isolated
Bus Power Required (24VDC)	Max. 100mA (All Outputs On)
Protection Circuit	Not built into the module - Install protection elements such as external fuse.
Terminal Block Replacement	AutomationDirect p/n C0-16TB
Weight	4.4 oz (125g)

Equivalent Output Circuit

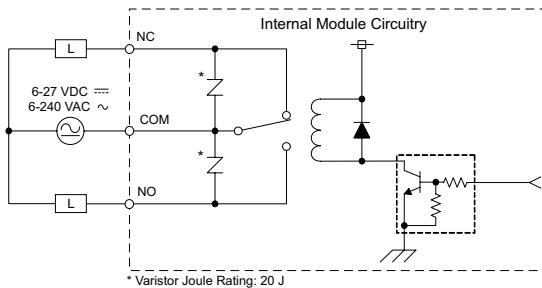

Output Temperature Derating Chart

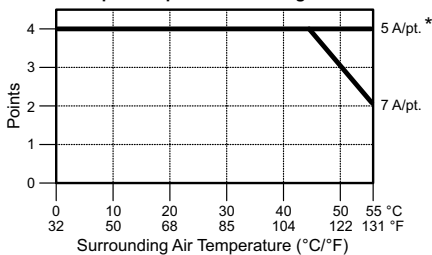

* No derating when the load current is 5A or less for each output point.

Typical Relay Life (Operations) at Room Temperature

Voltage & Load Type	Relay Life
30VDC, 7A Resistive	100,000 cycles
250VAC, 7A Resistive	100,000 cycles
250VAC, 4.9 A Solenoid	90,000 cycles
250VAC, 2.9 A Solenoid	100,000 cycles

ON to OFF = 1 cycle

ZIPLink Pre-Wired PLC Connection

Cables and Modules for CLICK PLC



20-pin connector cable
 ZL-C0-CBL20 (0.5 m length)
 ZL-C0-CBL20-1 (1.0 m length)
 ZL-C0-CBL20-2 (2.0 m length)

ZL-RTB20
 20-pin feed-through connector module

NOTE: The C0-04TRS relay output module is derated to 2A per point maximum when used with the ZIPLink wiring system.

C0-04TRS-10 – 4-Point Relay Output Module

4-point 6–240 VAC / 6–24VDC Isolated relay output module, 4 Form A (SPST) relays, 4 isolated commons, 10A/point, removable terminal block included.

Wiring Diagram

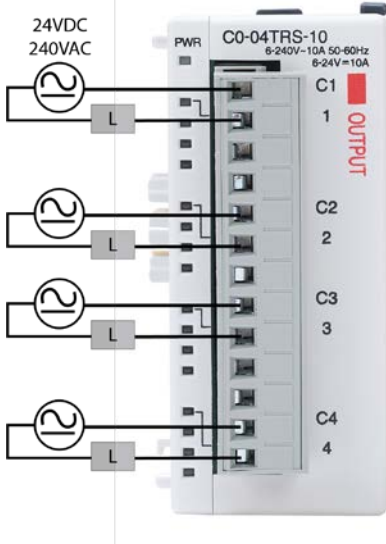

Output Specifications	
Outputs per Module	4
Operating Voltage Range	6–24 VDC / 6–240 VAC
Peak Voltage	24VDC / 264VAC
Output Type	Relay, form A (SPST)
AC Frequency	47–63 Hz
Maximum Current	10A / point, 10A / common
Minimum Load Current	100mA @ 5VDC
Maximum Inrush Current	16A for 10ms
OFF to ON Response	< 15ms
ON to OFF Response	< 15ms
Status Indicators	Logic Side (4 points, red LED) Power Indicator (green LED)
Commons	4 (1 point/common) Isolated
Bus Power Required (24VDC)	Max. 120mA (All Outputs On)
Protection Circuit	Not built into the module - Install protection elements such as external fuse.
Terminal Block Replacement	AutomationDirect p/n C0-8TB-1
Weight	5.22 oz (148g)

Typical Relay Life (Operations) at Room Temperature	
Voltage & Load Type	Relay Life
24VDC, 10A Resistive	120,000 cycles
24VDC, 10A Inductive	60,000 cycles
110VAC, 10A Resistive	120,000 cycles
110VAC, 10A Inductive	35,000 cycles
220VAC, 10A Resistive	120,000 cycles
220VAC, 10A Inductive	35,000 cycles
ON to OFF = 1 cycle	

Output Temperature Derating Chart

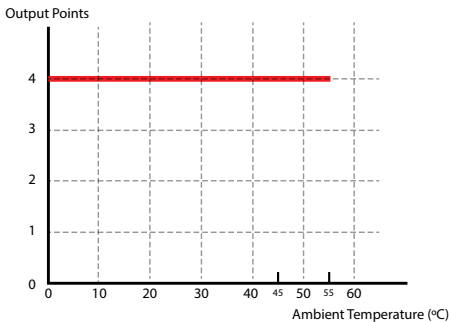

Equivalent Output Circuit

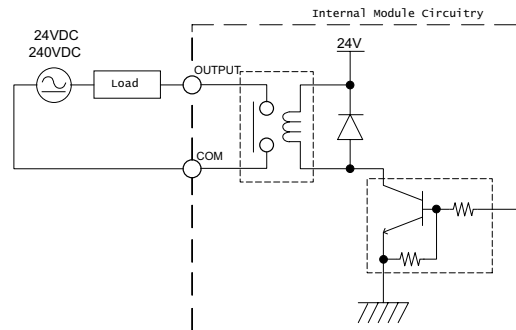

Chapter 2: Specifications

C0-08TR – 8-Point Relay Output Module

8-point 6–240 VAC /6–27 VDC relay output module, 8 Form A (SPST) relays, 2 commons, isolated, 4 A/common, removable terminal block included.

Wiring Diagram

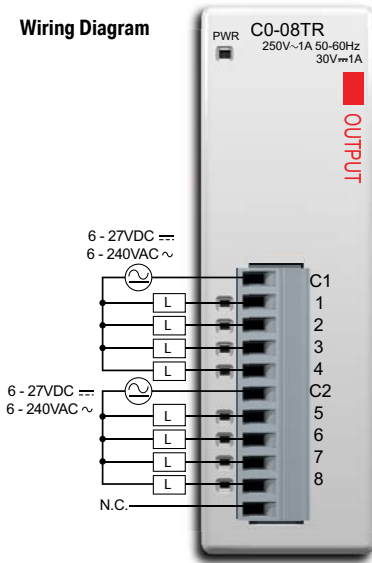

N.C. = Not Connected

Equivalent Output Circuit

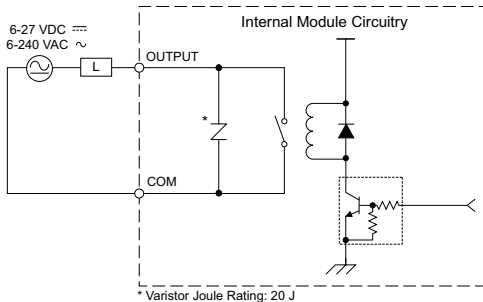

Output Temperature Derating Chart

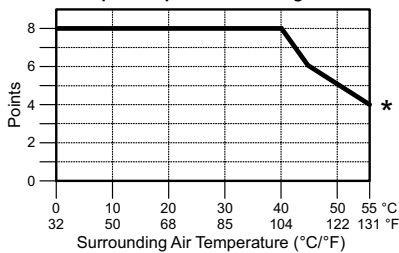

* Use every other output.

Output Specifications

Outputs per Module	8
Operating Voltage Range	6–27 VDC / 6–240 VAC
Output Voltage Range	5–30 VDC / 5–264 VAC
Output Type	Relay, form A (SPST)
AC Frequency	47–63 Hz
Maximum Current (resistive)	1A /point, 4A /common
Minimum Load Current	5mA @ 5VDC
Maximum Leakage Current	0.1 mA @ 264VAC
Maximum Inrush Current	3A for 10ms
OFF to ON Response	< 15ms
ON to OFF Response	< 15ms
Status Indicators	Logic Side (8 points, red LED) Power Indicator (green LED)
Commons	2 (4 points/common) Isolated
Bus Power Required (24VDC)	Max. 100mA (All Outputs On)
Protection Circuit	Not built into the module - Install protection elements such as external fuse.
Terminal Block Replacement	AutomationDirect p/n C0-8TB
Weight	3.9 oz (110g)

Typical Relay Life (Operations) at Room Temperature

Voltage & Load Type	Relay Life
30VDC, 1A Resistive	300,000 cycles
30VDC, 1A Solenoid	50,000 cycles
250VAC, 1A Resistive	500,000 cycles
250VAC, 1A Solenoid	200,000 cycles

ON to OFF = 1 cycle

ZIPLink Pre-Wired PLC Connection Cables and Modules for CLICK PLC



11-pin connector cable
 ZL-C0-CBL11 (0.5 m length)
 ZL-C0-CBL11-1 (1.0 m length)
 ZL-C0-CBL11-2 (2.0 m length)



ZL-RTB20
 20-pin feed-through
 connector module



NOTE: The C0-08TR is derated to 2A maximum per Common when used with the ZIPLink wiring system.

C0-08TR-3 – 8-Point Relay Output Module

8-point 6–240 VAC /6–27 VDC relay output module, 8 Form A (SPST) relays, 4 commons, isolated, 3A/point, removable terminal block included.

Wiring Diagram

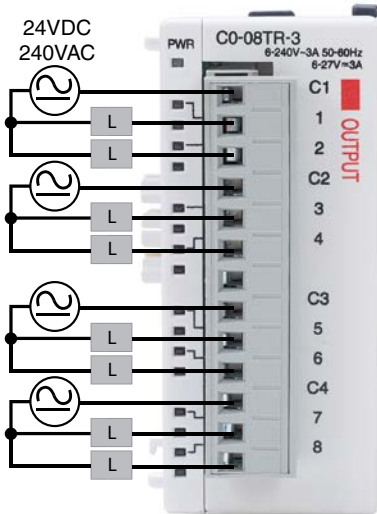

Output Specifications

Outputs per Module	8
Operating Voltage Range	6–27 VDC / 6–240 VAC
Peak Voltage	30 VDC / 264 VAC
Output Type	Relay, form A (SPST)
AC Frequency	47–63 Hz
Maximum Current (resistive)	3A /point, 6A /common
Minimum Load Current	5mA @ 5VDC
Maximum Inrush Current	5A for 10ms
OFF to ON Response	< 15ms
ON to OFF Response	< 15ms
Status Indicators	Logic Side (8 points, red LED) Power Indicator (green LED)
Commons	4 (2 points/common) Isolated
Bus Power Required (24VDC)	Max. 90mA (All Outputs ON)
Protection Circuit	Not built into the module - Install protection elements such as external fuse.
Terminal Block Replacement	AutomationDirect p/n C0-8TB-1
Weight	4.12 oz (117g)

Typical Relay Life (Operations) at Room Temperature

Voltage & Load Type	Relay Life
24VDC, 3A Resistive	100,000 cycles
24VDC, 3A Inductive	50,000 cycles
110VAC, 3A Resistive	100,000 cycles
110VAC, 3A Inductive	25,000 cycles
220VAC, 3A Resistive	100,000 cycles
220VAC, 3A Inductive	25,000 cycles
ON to OFF = 1 cycle	

Output Temperature Derating Chart

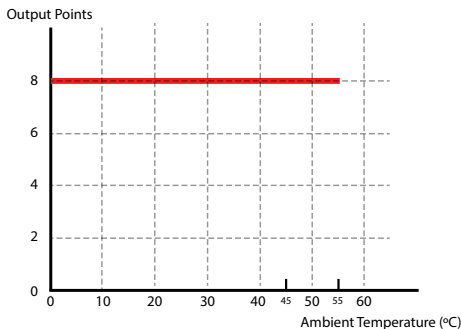

Equivalent Output Circuit

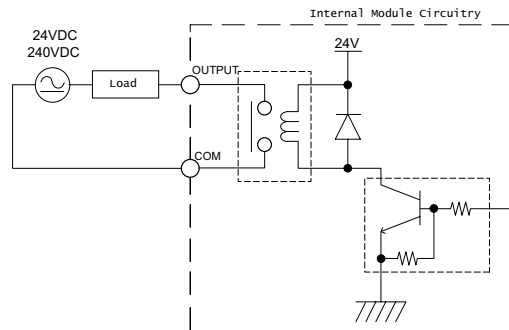

Chapter 2: Specifications

C0-16CDD1 – 8-Point DC Input and 8-Point DC Sinking Output Module

8-point 24VDC current sinking/sourcing input, 1 common, 8-point 5–27 VDC sinking output, 0.1A/pt., 1 common, non-fused, removable terminal block included.

Wiring Diagram

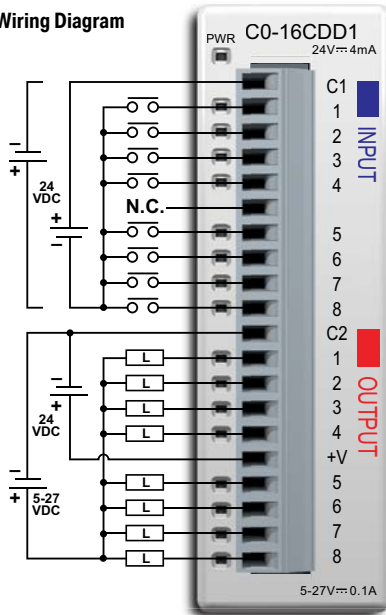

N.C. = Not Connected

Input Specifications

Inputs per Module	8 (Source/Sink)
Operating Voltage Range	CE: 24VDC (-10%/+10%) UL: 24VDC (-10%/+10%)
Input Voltage Range	21.6 – 26.4 VDC
Input Current	Typ 4.0 mA @ 24VDC
Maximum Input Current	5.0 mA @ 26.4 VDC
Input Impedance	6.8 kΩ @ 24VDC
ON Voltage Level	>19.0 VDC
OFF Voltage Level	<7.0 VDC
Minimum ON Current	3.5 mA
Maximum OFF Current	0.5 mA
OFF to ON Response	Max. 10ms Typ 2ms
ON to OFF Response	Max. 10ms Typ 3ms
Status Indicators	Logic Side (8 points, green LED) Power Indicator (green LED)
Commons	1 (8 points/common)

General Specifications

Bus Power Required (24VDC)	Max. 80mA (all points on)
Terminal Block Replacement	AutomationDirect p/n C0-16TB
Weight	3.2 oz (90g)



NOTE: When using this module you must also use *CLICK* programming software and PLC firmware version V1.40 or later.

Equivalent Input Circuit

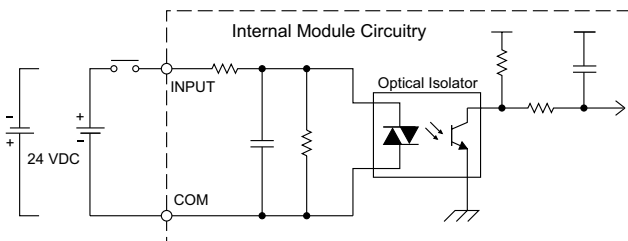

Input Module Temperature Derating Chart

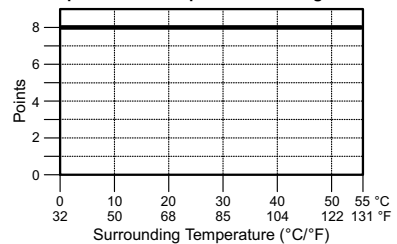

C0-16CDD1 (continued)

Output Specifications	
Outputs per Module	8 (sink) CE: 5-24 VDC (-15%/+20%) UL: 5-27 VDC (-15%/+20%)
Operating Voltage Range	4-30 VDC
Output Voltage Range	0.1 A/point, 0.8 A/common
Maximum Output Current	0.2 mA
Minimum Output Current	0.1 mA @ 30VDC
Maximum Leakage Current	0.5 VDC @ 0.1 A
On Voltage Drop	0.15 A for 10ms
Maximum Inrush Current	< 0.5 ms
OFF to ON Response	< 0.5 ms
ON to OFF Response	Logic Side (8 points, red LED)
Status Indicators	1 (8 points/common)
Commons	24VDC (-10%/+10%) max. 50mA (all points on)

Equivalent Output Circuit

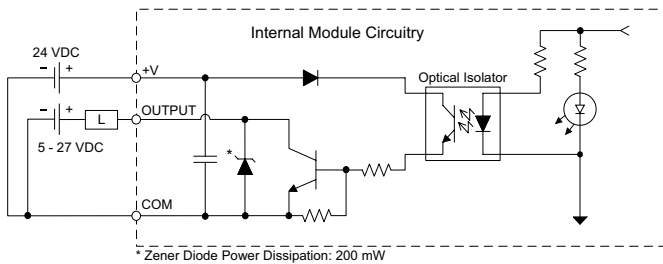

Output Module Temperature Derating Chart

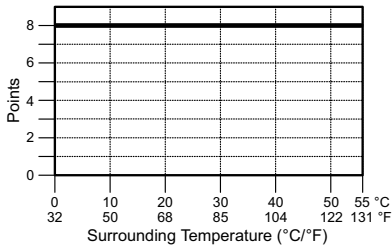

ZIPLink Pre-Wired PLC Connection Cables and Modules for CLICK PLC



ZL-RTB20
20-pin feed-through connector module

- 20-pin connector cable
- ZL-C0-CBL20 (0.5 m length)
- ZL-C0-CBL20-1 (1.0 m length)
- ZL-C0-CBL20-2 (2.0 m length)



Chapter 2: Specifications

C0-16CDD2 – 8-Point DC Input and 8-Point DC Sourcing Output Module

8-point 24VDC current sinking/sourcing input, 1 common, 8-point 12–24 VDC sourcing output, 0.1A/pt, 1 common, non-fused, removable terminal block included.

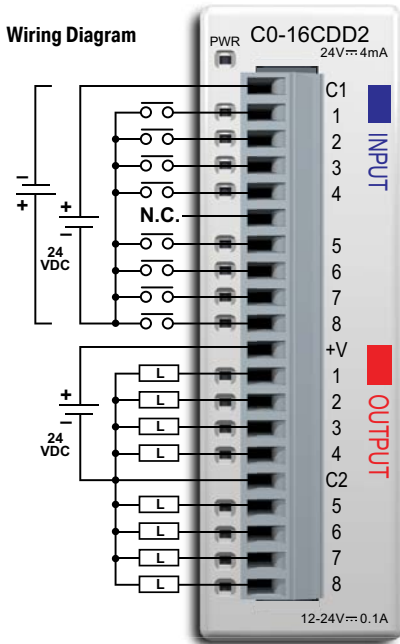

N.C. = Not Connected

Input Specifications	
Inputs per Module	8 (source/sink)
Operating Voltage Range	CE: 24VDC (-10%/+10%) UL: 24VDC (-10%/+10%)
Input Voltage Range	21.6 – 26.4 VDC
Input Current	Typ 4.0 mA @ 24VDC
Maximum Input Current	5.0 mA @ 26.4 VDC
Input Impedance	6.8 kΩ @ 24VDC
ON Voltage Level	>19.0 VDC
OFF Voltage Level	<7.0 VDC
Minimum ON Current	3.5 mA
Maximum OFF Current	0.5 mA
OFF to ON Response	Max. 10ms Typ 2ms
ON to OFF Response	Max. 10ms Typ 3ms
Status Indicators	Logic Side (8 points, green LED) Power Indicator (green LED)
Commons	1 (8 points/common)

General Specifications	
Bus Power Required (24VDC)	Max. 80mA (all points on)
Terminal Block Replacement	AutomationDirect p/n C0-16TB
Weight	3.2 oz (90g)



NOTE: When using this module you must also use CLICK programming software and PLC firmware version V1.40 or later.

Equivalent Input Circuit

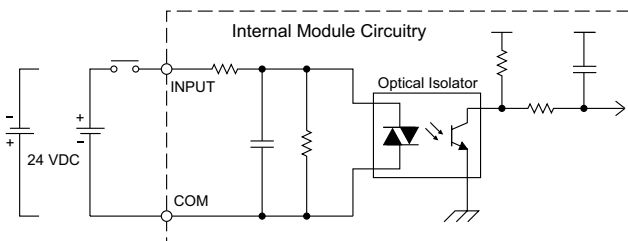

Input Module Temperature Derating Chart

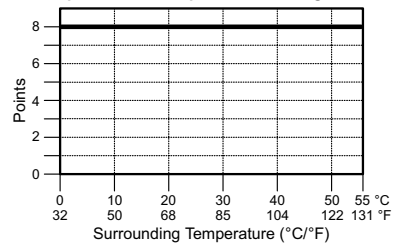

C0-16CDD2 (continued)

Output Specifications	
Outputs per Module	8 (Source)
Operating Voltage Range	CE: 12–24 VDC (-15%/+20%) UL: 12–24 VDC (-20%/+25%)
Output Voltage Range	9.6–30 VDC
Maximum Output Current	0.1 A/point, 0.8 A/common
Minimum Output Current	0.2 mA
Maximum Leakage Current	0.1 mA @ 30VDC
On Voltage Drop	0.6 VDC @ 0.1 A
Maximum Inrush Current	0.15 A for 10ms
OFF to ON Response	<0.5 ms
ON to OFF Response	<0.5 ms
Status Indicators	Logic Side (8 points, red LED)
Commons	1 (8 points/common)

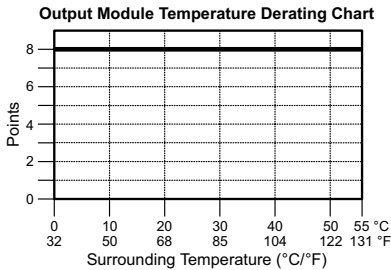
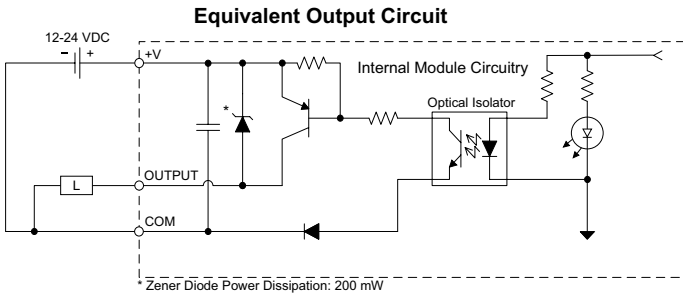

ZIPLink Pre-Wired PLC Connection Cables and Modules for CLICK PLC



ZL-RTB20
20-pin feed-through connector module

- 20-pin connector cable
- ZL-C0-CBL20 (0.5 m length)
- ZL-C0-CBL20-1 (1.0 m length)
- ZL-C0-CBL20-2 (2.0 m length)



Chapter 2: Specifications

C0-08CDR – 4-Point DC Input and 4-Point Relay Output Module

4-point 12–24 VDC current sinking/sourcing input, 1 common, 4-point 6.25–24 VDC / 6–240 VAC relay output, Form A (SPST) relays 1A/pt, 1 common, non-fused, removable terminal block included.

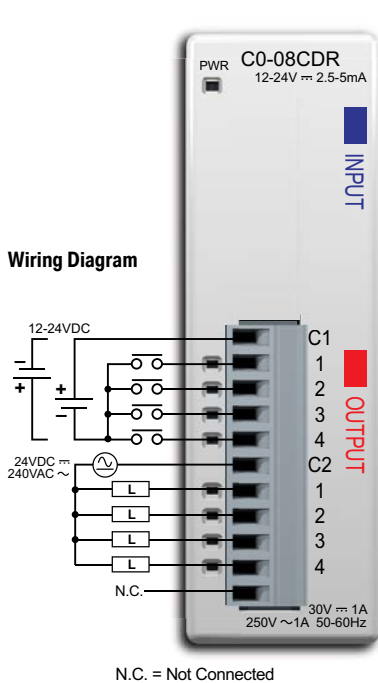

Input Specifications	
Inputs per Module	4 (source/sink)
Operating Voltage Range	CE: 12–24 VDC (-10%/+10%) UL: 12–24 VDC (-10%/+10%)
Input Voltage Range	10.8 – 26.4 VDC
Input Current	Typ 5.0 mA @ 24VDC
Maximum Input Current	7.0 mA @ 26.4 VDC
Input Impedance	4.7 kΩ @ 24VDC
ON Voltage Level	>8.0 VDC
OFF Voltage Level	<3.0 VDC
Minimum ON Current	1.4 mA
Maximum OFF Current	0.5 mA
OFF to ON Response	Max. 3.5 ms Typ 2ms
ON to OFF Response	Max. 4ms Typ 2.5 ms
Status Indicators	Logic Side (4 points, green LED) Power Indicator (green LED)
Commons	1 (4 points/common)

General Specifications	
Bus Power Required (24VDC)	Max. 80mA (all points on)
Protection Circuit	Not built into the module - Install protection elements such as external fuse
Terminal Block Replacement	AutomationDirect p/n C0-8TB
Weight	3.2 oz (90g)



NOTE: When using this module you must also use CLICK programming software and PLC firmware version V1.40 or later.

Equivalent Input Circuit

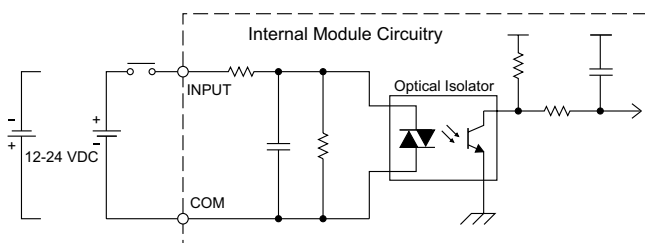

Input Temperature Derating Chart

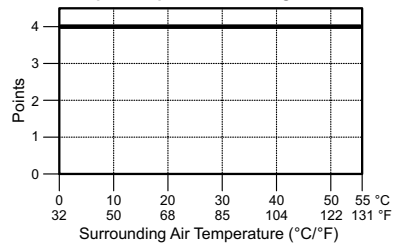

C0-08CDR (continued)

Output Specifications	
Outputs per Module	4 (Relay)
Operating Voltage Range	CE: 6.25–24 VDC (-15%/+10%) / 6–240 VAC (-15%/+10%) UL: 24VDC (-15%/+10%) / 240VAC (-10%/+10%)
Peak Voltage	30VDC / 264VAC
Output Type	Relay, Form A (SPST)
AC Frequency	47–63 Hz
Maximum Current	1A /point, 4 A/common
Minimum Load Current	5mA @ 5VDC
Maximum Leakage Current	0.1 mA @ 264VAC
Maximum Inrush Current	3A for 10ms
OFF to ON Response	<15ms
ON to OFF Response	<15ms
Status Indicators	Logic Side (4 points, red LED)
Commons	1 (4 points/common)

Typical Relay Life (Operations) at Room Temperature	
Voltage & Load Type*	Relay Life (ON to OFF = 1 cycle)
30VDC, 1A, Resistive	80,000 cycles
30VDC, 1A, Solenoid	80,000 cycles
250VAC, 1A, Resistive	80,000 cycles
250VAC, 1A, Solenoid	80,000 cycles

* These relay outputs support both inductive (solenoid) and resistive loads.

Equivalent Output Circuit

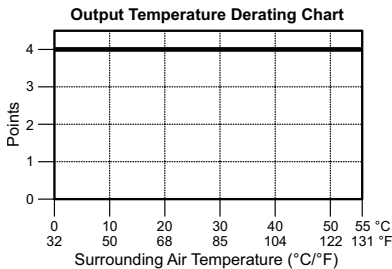
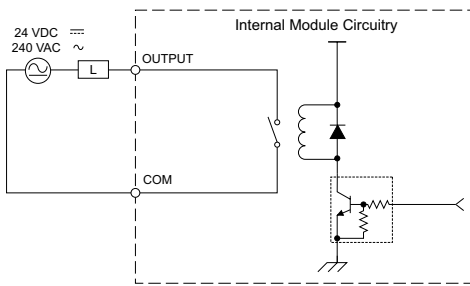

ZIPLink Pre-Wired PLC Connection Cables and Modules for CLICK PLC



ZL-RTB20
20-pin feed-through connector module



11-pin connector cable
ZL-C0-CBL11 (0.5 m length)
ZL-C0-CBL11-1 (1.0 m length)
ZL-C0-CBL11-2 (2.0 m length)

C0-04AD-1 – 4-Channel Analog Current Input Module

4-channel analog current sinking input module, 13-bit resolution, range: 0–20 mA. External 24VDC power required, removable terminal block included.

Wiring Diagram

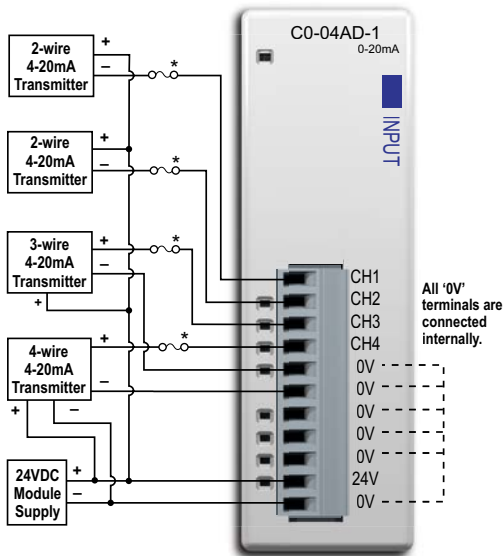

NOTE: When using this module you must also use **CLICK** programming software and PLC firmware version V1.40 or later.

Input Specifications

Inputs per Module	4
Input Range	0–20 mA (sink)
Resolution	13-bit, 2.44 μ A/count
Input Type	Single ended (one common)
Maximum Continuous Overload	\pm 44mA
Input Impedance	124 Ω , 0.5 W current input
Filter Characteristics	Low pass, -3 dB at 120Hz
Sample Duration Time	2ms
All Channel Update Rate	25ms
Open Circuit Detection Time	Zero reading within 100ms
Accuracy vs. Temperature	\pm 75 PPM/ $^{\circ}$ C maximum
Maximum Inaccuracy	0.5% of range (including temperature changes)
Linearity Error (End to End)	\pm 3 count maximum, monotonic with no missing codes
Input Stability and Repeatability	\pm 2 count maximum
Full Scale Calibration Error (including Offset)	\pm 8 count maximum
Offset Calibration Error	\pm 8 count maximum
Maximum Crosstalk at DC, 50/60 Hz	\pm 2 count maximum
Field to Logic Side Isolation	1800VAC for 1 sec.
Recommended Fuse (external)	AutomationDirect p/n S500-32-R (0.032A fuse)
External 24VDC Power Required	65mA
Bus Power Required (24VDC)	20mA
Terminal Block Replacement	AutomationDirect p/n C0-8TB
Weight	2.9 oz (82g)

ZIPLink Pre-Wired PLC Connection Cables and Modules for CLICK PLC



ZL-RTB20 20-pin feed-through connector module



11-pin connector cable
 ZL-C0-CBL11 (0.5 m length)
 ZL-C0-CBL11-1 (1.0 m length)
 ZL-C0-CBL11-2 (2.0 m length)

C0-04AD-2 – 4-Channel Analog Voltage Input Module

4-channel analog voltage input module, 13-bit resolution, range: 0–10V. External 24VDC power required, removable terminal block included.

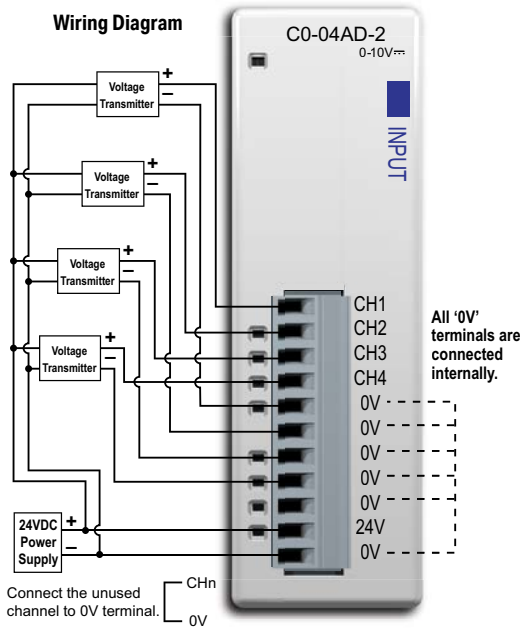

NOTE: When using this module you must also use **CLICK programming software and PLC firmware version V1.40 or later.**

Input Specifications	
Inputs per Module	4
Input Range	0–10 V
Resolution	13-bit, 1.22 mV per count
Input Type	Single ended (one common)
Maximum Continuous Overload	±100VDC
Input Impedance	>150kΩ
Filter Characteristics	Low pass, -3 dB at 500Hz
Sample Duration Time	6.25 ms
All Channel Update Rate	25ms
Open Circuit Detection Time	Zero reading within 100 ms
Accuracy vs. Temperature	±75 PPM/°C maximum
Maximum Inaccuracy	0.5% of range (including temperature changes)
Linearity Error (End to End)	±3 count maximum, monotonic with no missing codes
Input Stability and Repeatability	±2 count maximum
Full Scale Calibration Error (Including Offset)	±8 count maximum
Offset Calibration Error	±8 count maximum
Maximum Crosstalk at DC, 50/60 Hz	±2 count maximum
Field to Logic Side Isolation	1800VAC for 1 sec.
External 24VDC Power Required	65mA
Base Power Required (24VDC)	23mA
Terminal Block Replacement	AutomationDirect p/n C0-8TB
Weight	2.9 oz (82g)

ZIPLink Pre-Wired PLC Connection Cables and Modules for CLICK PLC



11-pin connector cable
 ZL-C0-CBL11 (0.5 m length)
 ZL-C0-CBL11-1 (1.0 m length)
 ZL-C0-CBL11-2 (2.0 m length)



C0-04RTD – 4-Channel RTD Input Module

4-channel RTD input module, 16-bit resolution (± 0.1 degrees Celsius or Fahrenheit), supports: Pt100, Pt1000, jPt100, Cu10, Cu25, Ni120. Resistive ranges also supported, removable terminal block included.

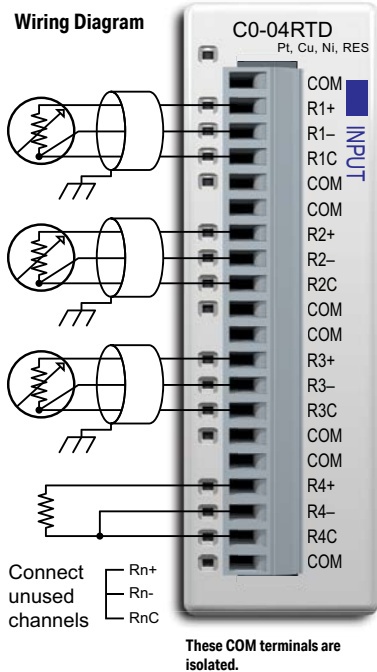

NOTE: The C0-04RTD module cannot be used with thermistors.

NOTE: When using this module you must also use CLICK programming software and PLC firmware version V1.40 or later.

If there are any unused channels, make sure to select the correct number of channels that you actually use in the C0-04RTD Setting window.

General Specifications	
Field to Logic Side Isolation	No isolation
External DC Power Required	None
Bus Power Required (24VDC)	25mA
Thermal Dissipation	2.047 BTU per hour
Terminal Block Replacement	AutomationDirect p/n C0-16TB
Weight	3.1 oz (86g)

Input Specifications	
Inputs per Module	4
Common Mode Range	± 2.5 V
Common Mode Rejection	100dB at DC and 100 dB at 50/60 Hz
Input Impedance	>5M Ω
Maximum Ratings	Fault protected inputs to ± 50 VDC
Resolution	$\pm 0.1^\circ\text{C}$ or $^\circ\text{F}$, 0.1 Ω or 0.01 Ω
Input Ranges*	Pt100: -200 to 850 $^\circ\text{C}$ (-328 to 1562 $^\circ\text{F}$)
	Pt1000: -200 to 595 $^\circ\text{C}$ (-328 to 1103 $^\circ\text{F}$)
	jPt100: -100 to 450 $^\circ\text{C}$ (-148 to 842 $^\circ\text{F}$)
	10 Ω Cu: -200 to 260 $^\circ\text{C}$ (-328 to 500 $^\circ\text{F}$)
	25 Ω Cu: -200 to 260 $^\circ\text{C}$ (-328 to 500 $^\circ\text{F}$)
	120 Ω Ni: -80 to 260 $^\circ\text{C}$ (-112 to 500 $^\circ\text{F}$)
	0 to 3125.0 Ω : Resolution 0.1 Ω
0 to 1562.5 Ω : Resolution 0.1 Ω	
0 to 781.2 Ω : Resolution 0.1 Ω	
0 to 390.62 Ω : Resolution 0.01 Ω	
0 to 195.31 Ω : Resolution 0.01 Ω	
RTD Linearization	Automatic
Excitation Current (All Ranges)	210 μA

* While it is possible to use different resistive ranges, we recommend using the narrowest range that covers the resistance being measured. For example, if measuring approximately 100 ohms resistance, use the 0 to 195.31 ohms range. While the resolution is the same as the 0 to 390.62 ohms range, output RMS noise will be lower and stability will be improved.

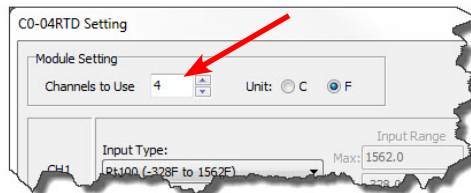

C0-04RTD – 4-Channel RTD Input Module (continued)

Input Specifications (continued)	
Accuracy vs. Temperature	±10ppm per °C maximum
RTD Input Maximum Inaccuracy	±3°C (excluding RTD error); ±5°C (ranges Cu10 and Cu25)
RTD Linearity Error (End to End)	±2°C maximum, ±0.5°C typical, monotonic with no missing codes
Resistance Input Maximum Zero Scale Error	±0.0015% of full scale range in ohms (negligible)
Resistance Input Maximum Full Scale Error	±0.02% of full scale range
Maximum Linearity Error	±0.015% of full scale range maximum at 25°C, monotonic with no missing codes
Resistance Maximum Input Inaccuracy	0.1% at 0 to 60°C (32° to 140° F), typical 0.04% at 25°C (77° F)
Warm Up Time	30 minutes for ±1C° repeatability
Single Channel Update Rate	240ms
All Channel Update Rate	Single Channel Update Rate times the number of enabled channels on the module
Open Circuit Detection Time	Positive full-scale reading within 2 seconds
Conversion Method	Sigma - Delta



Not Compatible with ZIPLink Pre-Wired PLC Connection Cables and Modules.



NOTE: When this module is used in a CLICK PLC system, it takes up to 24 seconds for initialization after power-up. During this time period, the RUN LED on the PLC module blinks to indicate the initialization process.

Initialization Time		
The Number of Channels Used	The same Input Type is selected for all Channels	Mixed Input Types are selected
1	4 sec	N/A
2	5 sec	May take up to 13 sec
3	6 sec	May take up to 18 sec
4	7 sec	May take up to 24 sec

CO-04THM – 4-Channel Thermocouple Input Module

4-channel thermocouple input module, 16-bit resolution (± 0.1 degrees Celsius or Fahrenheit), Supports: J, K, E, R, S, T, B, N, C type thermocouples; voltages ranges also supported, removable terminal block included.

Wiring Diagram

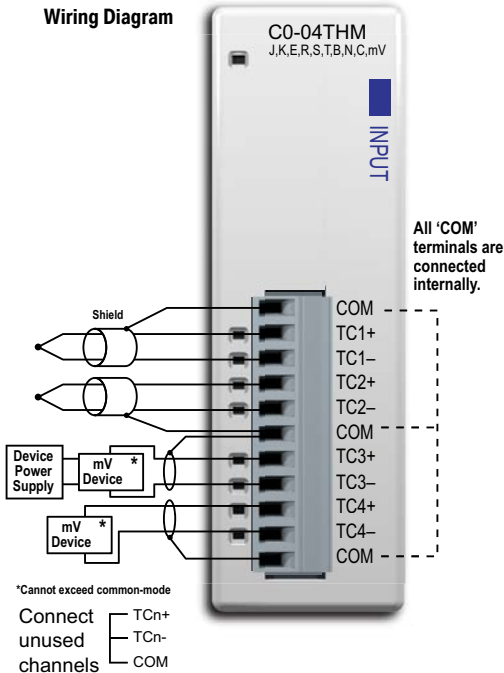

NOTE: When using this module you must also use CLICK programming software and PLC firmware version V1.40 or later.

General Specifications	
Field to Logic Side Isolation	1800 VAC applied for 1 second (100% tested)
External DC Power Required	None
Bus Power Required (24VDC)	25mA
Thermal Dissipation	0.175 BTU per hour
Terminal Block Replacement	AutomationDirect p/n CO-8TB
Weight	3.1 oz (86 g)

Input Specifications	
Inputs per Module	4
Common Mode Range	-1.3 to +3.8 V
Common Mode Rejection	100dB at DC and 130dB at 60Hz
Input Impedance	>5M Ω
Maximum Ratings	Fault protected inputs to ± 50 VDC
Resolution	$\pm 0.1^\circ\text{C}$ or $^\circ\text{F}$, 16-bit
Input Ranges	Type J: -190 to 760 $^\circ\text{C}$ (-310 to 1400 $^\circ\text{F}$)
	Type K: -150 to 1372 $^\circ\text{C}$ (-238 to 2502 $^\circ\text{F}$)
	Type E: -210 to 1000 $^\circ\text{C}$ (-346 to 1832 $^\circ\text{F}$)
	Type R: 65 to 1768 $^\circ\text{C}$ (149 to 3214 $^\circ\text{F}$)
	Type S: 65 to 1768 $^\circ\text{C}$ (149 to 3214 $^\circ\text{F}$)
	Type T: -230 to 400 $^\circ\text{C}$ (-382 to 752 $^\circ\text{F}$)
	Type B: 529 to 1820 $^\circ\text{C}$ (984 to 3308 $^\circ\text{F}$)
	Type N: -70 to 1300 $^\circ\text{C}$ (-94 to 2372 $^\circ\text{F}$)
	Type C: 65 to 2320 $^\circ\text{C}$ (149 to 4208 $^\circ\text{F}$)
	± 39.0625 mV
	± 78.125 mV
	0 to 156.25 mV
	± 156.25 mV
	0 to 1.25 V

If there are any unused channels, make sure to select the correct number of channels that you actually use in the CO-04THM Setting window.

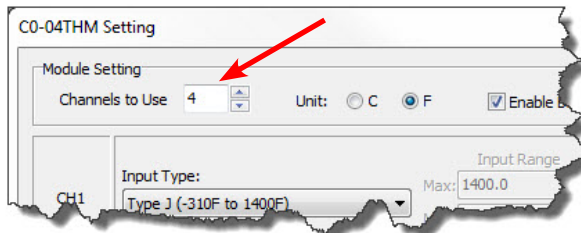

C0-04THM – 4-Channel Thermocouple Input Module (continued)

Input Specifications (continued)	
Cold Junction Compensation	Automatic
Thermocouple Linearization	Automatic
Accuracy vs. Temperature	±25 ppm per °C maximum
Linearity Error	±2°C maximum, ±1°C typical, monotonic with no missing codes
Maximum Inaccuracy	±3°C maximum (excluding thermocouple error)
Maximum Voltage Input Offset Error	0.05% at 0° to 55° C (32° to 131° F), typical 0.04% at 25° C (77° F)
Maximum Voltage Input Gain Error	0.06% at 25°C (77°F)
Maximum Voltage Input Linearity Error	0.05% at 0° to 55°C (32° to 131°F), typical 0.03% at 25°C (77°F)
Maximum Voltage Input Inaccuracy	0.1% at 0° to 55°C (32° to 131°F), typical 0.04% at 25°C (77°F)
Warm Up Time	30 minutes for ±1C° repeatability
Single Channel Update Rate	400ms
All Channel Update Rate	Single Channel Update Rate times the number of enabled channels on the module
Open Circuit Detection Time	Burn Out flag set and zero scale reading within 3 seconds
Conversion Method	Sigma - Delta

Not Compatible with ZIPLink Pre-Wired PLC Connection Cables and Modules.



NOTE: When this module is used in a CLICK PLC system, it takes up to 11 seconds for initialization after power-up. During this time period, the RUN LED on the PLC module blinks to indicate the initialization process.

Initialization Time	
The Number of Channels Used	With any Configuration
1	5 sec
2	7 sec
3	9 sec
4	11 sec



NOTE: With grounded thermocouples, take precautions to prevent having a voltage potential between thermocouple tips. A voltage less than -1.3V or greater than +3.8V between tips will skew measurements.

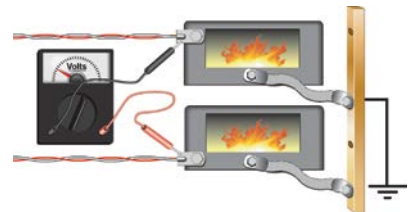

C0-04DA-1 – 4-Channel Analog Current Output Module

4-channel analog current sourcing output module, 12-bit resolution, range: 4–20 mA. External 24VDC power required, removable terminal block included.

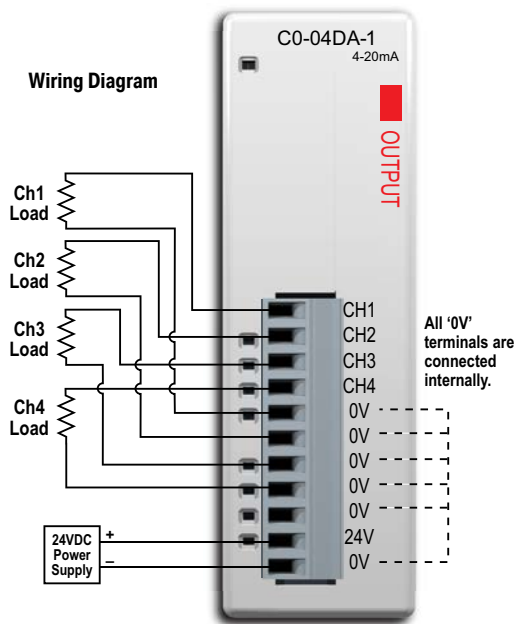

NOTE: When using this module you must also use CLICK programming software and PLC firmware version V1.40 or later.

Output Specifications	
Outputs per Module	4
Output Range	4–20 mA (source)
Resolution	12-bit, 3.9 uA per count
Output Type	Current sourcing at 20mA max.
Output Value in Fault Mode	Less than 4mA
Load Impedance	0-600Ω at 24VDC; minimum load: 0Ω 32° to 131°F (0° to 55°C) ambient temp.
Maximum Inductive Load	1mH
Allowed Load Type	Grounded
Maximum Inaccuracy	±1% of range
Max. Full Scale Calibration Error (Including Offset)	±0.2% of range maximum
Max. Offset Calibration Error	±0.2% of range maximum
Accuracy vs. Temperature	±75 PPM/°C maximum full scale calibration change (±0.005% of range/°C)
Max. Crosstalk at DC, 50/60 Hz	-72 dB, 1 LSB
Linearity Error (End to End)	±4 LSB max., (±0.1% of full scale)
Output Stability and Repeatability	±2% LSB after 10 minute warmup period typical
Output Ripple	±0.1% of full scale
Output Settling Time	0.3 ms maximum, 5μs min. (full scale range)
All Channel Update Rate	10ms
Max. Continuous Overload	Outputs open circuit protected
Field to Logic Side Isolation	1800VAC applied for 1 second (100% tested)
Type of Output Protection	Electronically limited to 20mA or less
Output Signal at Power Up and Power Down	4mA
External VDC Power Required	145mA
Base Power Required (24VDC)	20mA
Terminal Block Replacement	AutomationDirect p/n C0-8TB
Weight	2.9 oz (82g)

Z/PLink Pre-Wired PLC Connection Cables and Modules for CLICK PLC

ZL-RTB20 20-pin feed-through connector module



11-pin connector cable
 ZL-C0-CBL11 (0.5 m length)
 ZL-C0-CBL11-1 (1.0 m length)
 ZL-C0-CBL11-2 (2.0 m length)



C0-04DA-2 – 4-Channel Analog Voltage Output Module

4-channel analog voltage output module, 12-bit resolution, range: 0–10 V. External 24VDC power required, removable terminal block included.

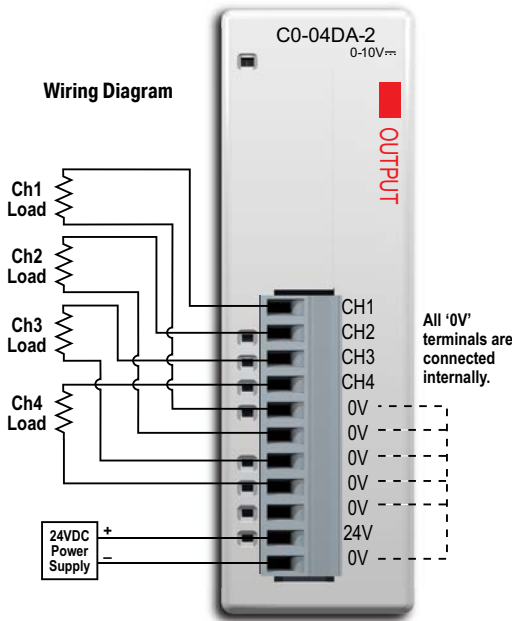

NOTE: When using this module you must also use CLICK programming software and PLC firmware version V1.40 or later.

ZIPLink Pre-Wired PLC Connection Cables and Modules for CLICK PLC

- 11-pin connector cable
- ZL-C0-CBL11 (0.5 m length)
- ZL-C0-CBL11-1 (1.0 m length)
- ZL-C0-CBL11-2 (2.0 m length)



ZL-RTB20 20-pin feed-through connector module



Output Specifications	
Outputs per Module	4
Output Range	0–10 V
Resolution	12-bit, 2.44 mV per count
Output Type	Voltage sourcing at 10mA max. (One common)
Output Value in Program Mode	Determined by PLC
Output Value in Fault Mode	0 V
Output Impedance	0.2 Ω typical
Load Impedance	>1000Ω
Maximum Capacitive Load	0.01 μF maximum
Allowed Load Type	Grounded
Maximum Inaccuracy	0.5% of range
Max. Full Scale Calibration Error (Not including Offset)	±0.2% of range maximum voltage
Max. Offset Calibration Error	±0.2% of range maximum
Accuracy vs. Temperature	±75 PPM/°C maximum full scale calibration change (±0.0025% of range/°C)
Max. Crosstalk at DC, 50/60 Hz	-72 dB, 1 LSB
Linearity Error (End to End)	±4 LSB max., (±0.1% of full scale); monotonic with no missing codes
Output Stability and Repeatability	±2% LSB after 10 minute warmup period typical
Output Ripple	0.1% of full scale
Output Settling Time	0.3 ms maximum, 5 μs minimum (full scale range)
All Channel Update Rate	10ms
Max. Continuous Overload	Outputs current limited to 40mA typical; continuous overloads on multiple outputs can damage module.
Field to Logic Side Isolation	1800VAC applied for 1 second (100% tested)
Type of Output Protection	0.1 μF transient suppressor
Output Signal at Power Up and Power Down	0 V
External 24VDC Power Required	85mA
Base Power Required (24VDC)	20mA
Terminal Block Replacement	AutomationDirect p/n C0-8TB
Weight	2.9 oz (82g)

C0-4AD2DA-1 – 4-Channel Analog Current Input and 2-Channel Analog Current Output Module

4-channel analog current sinking input (13-bit resolution) and 2-channel analog current sourcing output (12-bit resolution) module, range: 0–20 mA (inputs), 4–20 mA (outputs). External 24VDC power required, removable terminal block included.

Wiring Diagram

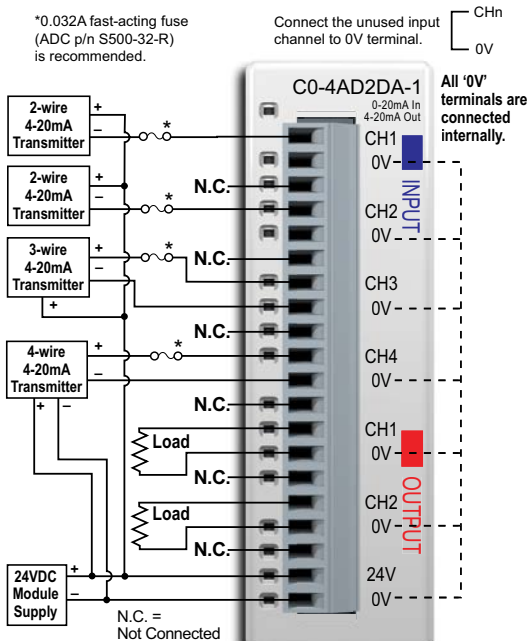

NOTE: When using this module you must also use CLICK programming software and PLC firmware version V1.40 or later.

Z/PLink Pre-Wired PLC Connection Cables and Modules for CLICK PLC

20-pin connector cable
 ZL-C0-CBL20 (0.5 m length)
 ZL-C0-CBL20-1 (1.0 m length)
 ZL-C0-CBL20-2 (2.0 m length)

ZL-RTB20 20-pin
 feed-through
 connector module



General Specifications

Field to Logic Side Isolation	1800VAC for 1 sec.
External 24VDC Power Required	75mA
Bus Power Required (24VDC)	25mA
Recommended Fuse (External)	AutomationDirect p/n S500-32-R (0.032 A fuse)
Terminal Block Replacement	AutomationDirect p/n C0-16TB
Weight	3.1 oz (86g)

Input Specifications

Inputs per Module	4
Input Range	0-20 mA (sink)
Resolution	13-bit, 2.44 μ A per count
Input Type	Single ended (one common)
Maximum Continuous Overload	\pm 44 mA
Input Impedance	124 Ω , 0.5 W current input
Filter Characteristics	Low pass, -3 dB at 400 Hz
PLC Data Format	13-bit unsigned Integer, range is 0-8191
Sample Duration Time	5 ms
All Channel Update Rate	20 ms (input plus output maximum time)
Open Circuit Detection Time	Zero reading within 20 ms
Conversion Method	Successive approximation
Accuracy vs. Temperature	\pm 75 PPM/ $^{\circ}$ C maximum
Maximum Inaccuracy	0.5% of range (including temperature changes)
Linearity Error (End to End)	\pm 3 count maximum, monotonic with no missing codes
Input Stability and Repeatability	\pm 2 count maximum
Full Scale Calibration Error (Including Offset)	\pm 8 count maximum
Offset Calibration Error	\pm 8 count maximum
Maximum Crosstalk at DC, 50/60 Hz	\pm 2 count maximum

C0-4AD2DA-1 – 4-Channel Analog Current Input and 2-Channel Analog Current Output Module (continued)

Output Specifications	
Outputs per Module	2
Output Range	4–20 mA (source)
Resolution	12-bit, 3.9 μ A per count
Output Type	Current sourcing at 20mA max. (One common)
PLC Data Format	12-bit unsigned integer, 0-4095 counts
Output Value in Fault Mode	Less than 4mA
Load Impedance	0–600 Ω at 24VDC; minimum load: 0 Ω 32° to 113°F (0° to 45°C); 125 Ω 113° to 131°F (45° to 55°C) ambient temp.
Maximum Inductive Load	1mH
Allowed Load Type	Grounded
Maximum Inaccuracy	\pm 1% of range
Max. Full Scale Calibration Error (Including Offset)	\pm 0.2% of range maximum
Max. Offset Calibration Error	\pm 0.2% of range maximum
Accuracy vs. Temperature	\pm 50 PPM/°C maximum full scale calibration change (\pm 0.005% of range/°C)
Max. Crosstalk at DC, 50/60 Hz	-72 dB, 1 LSB
Linearity Error (End to End)	\pm 4 LSB maximum, (\pm 0.1% of full scale), monotonic with no missing codes
Output Stability and Repeatability	\pm 2% LSB after 10 minute warmup period typical
Output Ripple	\pm 0.1% of full scale
Output Settling Time	0.2 ms maximum, 5 μ s min. (full scale range)
All Channel Update Rate	20ms
Max. Continuous Overload	Outputs open circuit protected
Type of Output Protection	Electronically limited to 20mA or less
Output Signal at Power Up or Power Down	4mA

C0-4AD2DA-2 – 4-Channel Analog Voltage Input and 2-Channel Analog Voltage Output Module

4-channel analog voltage input (13-bit resolution) and 2-channel analog voltage output (12-bit resolution) module, range: 0-10V. External 24VDC power required, removable terminal block included.

Wiring Diagram

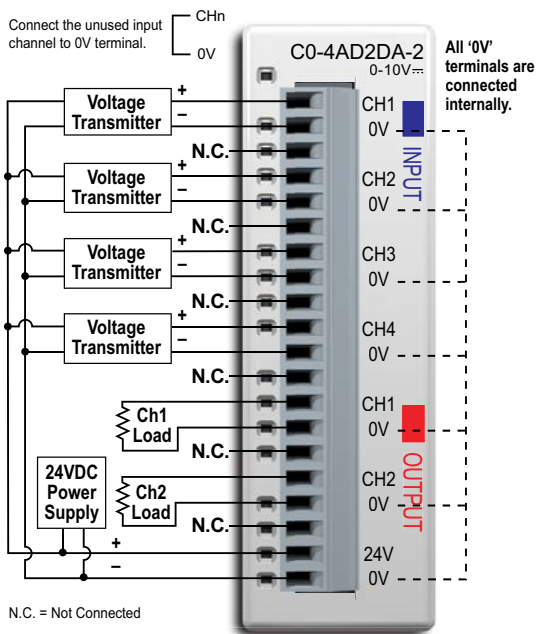

General Specifications

Field to Logic Side Isolation	1800VAC for 1 sec.
External 24VDC Power Required	65mA
Base Power Required (24VDC)	20mA
Terminal Block Replacement	AutomationDirect p/n C0-16TB
Weight	3.1 oz (86g)

Input Specifications

Inputs per Module	4
Input Range	0-10 V
Resolution	13-bit, 1.22 mV per count
Input Type	Single ended (one common)
Maximum Continuous Overload	±100VDC
Input Impedance	>150kΩ
Filter Characteristics	Low pass, -3dB at 500Hz
Sample Duration Time	5ms
All Channel Update Rate	20ms
Open Circuit Detection Time	Zero reading within 100ms
Conversion Method	Successive approximation
Accuracy vs. Temperature	±75 PPM/°C maximum
Maximum Inaccuracy	0.5% of range (including temperature changes)
Linearity Error (End to End)	±3 count maximum, monotonic with no missing codes
Input Stability and Repeatability	±2 count maximum
Full Scale Calibration Error (including Offset)	±8 count maximum
Offset Calibration Error	±8 count maximum
Maximum Crosstalk at DC, 50/60 Hz	±2 count maximum



NOTE: When using this module you must also use CLICK programming software and PLC firmware version V1.40 or later.

ZIPLink Pre-Wired PLC Connection Cables and Modules for CLICK PLC

20-pin connector cable
 ZL-C0-CBL20 (0.5 m length)
 ZL-C0-CBL20-1 (1.0 m length)
 ZL-C0-CBL20-2 (2.0 m length)



ZL-RTB20 20-pin feed-through connector module

C0-4AD2DA-2 – 4-Channel Analog Voltage Input and 2-Channel Analog Voltage Output Module (continued)

Output Specifications	
Outputs per Module	2
Output Range	0–10 V
Resolution	12-bit, 2.44 mV per count
Output Type	Voltage sourcing at 10mA max. (One common)
Output Value in Program Mode	Determined by PLC
Output Value in Fault Mode	0V
Output Impedance	0.2 Ω typical
Load Impedance	>1000 Ω
Maximum Capacitive Load	0.01 μ F maximum
Allowed Load Type	Grounded
Maximum Inaccuracy	1% of range
Max. Full Scale Calibration Error (Not including Offset)	\pm 0.2% of range maximum voltage
Max. Offset Calibration Error	\pm 0.2% of range maximum
Accuracy vs. Temperature	\pm 75 PPM/ $^{\circ}$ C maximum full scale calibration change (\pm 0.0025% of range/ $^{\circ}$ C)
Max. Crosstalk at DC, 50/60 Hz	-72dB, 1 LSB
Linearity Error (End to End)	\pm 4 LSB maximum, (\pm 0.1% of full scale); monotonic with no missing codes
Output Stability and Repeatability	\pm 2% LSB after 10 minute warmup period typical
Output Ripple	0.5% of full scale
Output Settling Time	0.3 ms maximum, 5 μ s minimum (full scale range)
All Channel Update Rate	20ms
Max. Continuous Overload	Outputs current limited to 40mA typical; continuous overloads on multiple outputs can damage module.
Type of Output Protection	0.1 μ F transient suppressor
Output Signal at Power Up or Power Down	0V

Power Supply Specifications

C0-00AC Power Supply

Limited auxiliary AC power supply allows you to power the CLICK PLC with 100-240 VAC supply power. The 0.5 A DC power supply is capable of controlling the PLC plus a limited configuration based on the power budget of each I/O module. The C0-00AC is a low-cost solution for applications requiring only minimal I/O and power consumption. This power supply will not support a fully-populated CLICK PLC system with all possible I/O module combinations.



C0-00AC Input Specifications	
Input Voltage Range	85-264 VAC
Input Frequency	47-63 Hz.
Input Current (typical)	0.3 A @ 100 VAC, 0.2 A @ 200VAC
Inrush Current	30A
Efficiency	80% typical

C0-00AC Output Specifications	
Output Voltage Range	23-25 VDC
Output Current	0.5 A
Ripple	200mV p-p max (0-55°C)
Ripple Noise	300mV p-p max (0-55°C)
Over Current Protection	@ 0.65 A (automatic recovery)
Over Voltage Protection	@ 27.6 V (clamped by Zener diode)
Start-up Time	1000ms max at rated input and load
Hold-up Time	10ms minimum at 85VAC, I=max

C0-00AC General Specifications	
Ambient Operating Temperature	32-131°F [0-55°C]
Storage Temperature	-4-158°F [-20-70°C]
Humidity	30-95%, non-condensing
Vibration Resistance	JIS C60068-2-6, sine wave vibration
Shock Resistance	JIS C60068-2-27
Voltage Withstand	
Input-Output	1500VAC, 5mA cutoff current
Input-Ground	1500VAC, 5mA cutoff current
Output-Ground	500VAC, 5mA cutoff current
Insulation Resistance	
Input-Output	10MΩ minimum, 500VDC
Input-Ground	10MΩ minimum, 500VDC
Output-Ground	5MΩ minimum, 500VDC
Noise Immunity	FCC Class A, EN55022:1998 Class A
Input/Output Interface	5P terminal block, Fujicon UF2362AX series or equivalent
Agency Approvals	UL508, UL1604, EN61010-1 (IEC 1010-1), CAN/CSA E60079-15:02, JIS C0025
Weight	5.3 oz [150g]

C0-01AC Power Supply

No-limit auxiliary AC power supply allows you to power the CLICK PLC with 100-240 VAC supply power. The 1.3 A DC power supply is capable of supporting a fully-populated CLICK PLC system with all possible I/O module combinations with no concerns of exceeding the power budget.



C0-01AC Input Specifications	
Input Voltage Range	85-264 VAC
Input Frequency	47-63 Hz.
Input Current (typical)	0.9 A @ 100 VAC, 0.6 A @ 200VAC
Inrush Current	30A
Efficiency	80% typical

C0-01AC Output Specifications	
Output Voltage Range	23-25 VDC
Output Current	1.3 A
Ripple	200mV p-p max (0-55°C)
Ripple Noise	300mV p-p max (0-55°C)
Over Current Protection	@ 1.6 A (automatic recovery)
Over Voltage Protection	@ 27.6 V (clamped by Zener diode)
Start-up Time	1000ms max at rated input and load
Hold-up Time	10ms minimum at 85VAC, I=max

C0-01AC General Specifications	
Ambient Operating Temperature	32-131°F [0-55°C]
Storage Temperature	-4-158°F [-20-70°C]
Humidity	30-95%, non-condensing
Vibration Resistance	JIS C60068-2-6, sine wave vibration
Shock Resistance	JIS C60068-2-27
Voltage Withstand	
Input-Output	1500VAC, 5mA cutoff current
Input-Ground	1500VAC, 5mA cutoff current
Output-Ground	500VAC, 5mA cutoff current
Insulation Resistance	
Input-Output	10MΩ minimum, 500VDC
Input-Ground	10MΩ minimum, 500VDC
Output-Ground	5MΩ minimum, 500VDC
Noise Immunity	FCC Class A, EN55022:1998 Class A
Input/Output Interface	5P terminal block, Fujicon UF2362AX series or equivalent
Agency Approvals	UL508, UL1604, EN61010-1 (IEC 1010-1), CAN/CSA E60079-15:02, JIS C0025
Weight	6.0 oz [170g]

PSP24-DC12-1 DC-DC Converter

With this DC-DC converter you can operate the CLICK PLC with 12VDC input power.



PSP24-DC12-1 DC-DC Converter Specifications	
Input Voltage Range	9.5–18 VDC
Input Power (no load)	1.0 W max.
Startup Voltage	8.4 VDC
Undervoltage Shutdown	7.6 VDC
Output Voltage Range	24–28 VDC (adjustable)
Output Current	1.0 A
Short Circuit Protection	Current limited at 110% typical
Weight	7.5 oz (213g)

Please see this part at www.automationdirect.com/pn/PSP24-DC12-1 on our web store for full specifications.

Programming Software

The CLICK PLC Programming Software, which can be downloaded free from the Automationdirect.com web site (Downloads/Software), is designed to provide simple and fast application development of ladder logic programming.

These are some of the features that help make this happen:

- The Navigation window allows organization of the ladder logic programs used in your project and access to the functions, settings and configurations used to work with your project.
- The Instruction List window displays all available CLICK PLC instructions, allows you to drag and drop the instruction into your ladder logic program, and then enter any values and/or parameters required for the particular instruction.
- You can add Subroutine and Interrupt programs separately from the main ladder logic program. This allows you to manage your ladder logic programs in a simple, structured environment and, at the same time, aid in trouble-shooting your program.
- The Data View Monitor window configurations are saved with your project. This allows quick access to the same set of memory addresses that may have been set up for viewing during testing of your program.
- The graphical represented System Configuration dialog box allows checking the PLC system configuration. A Power Budget calculation feature is included. Refer to the Power Budgeting section later in this chapter for additional details.
- The Address Picker window allows quick selection of any memory address to be placed in the ladder logic program. Refer to the programming software online help for additional details.
- The PLC module Firmware can be updated from the programming software within 7 minutes.

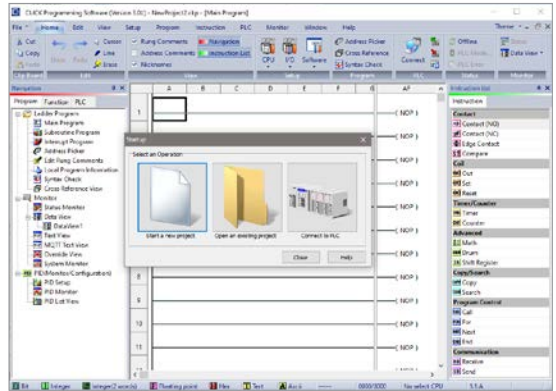

PC Requirements

Check our online webstore for current operating system requirements:







<http://www.automationdirect.com>

Data Types, Memory, and Numbering System

The following section explains how the CLICK PLC handles the available data types, memory addressing, and I/O numbering.

Data Types

The CLICK PLC supports the following data types. On the CLICK PLC programming software, each data type is indicated with a small icon.

Data Type	S/W Icon	Data Ranges
Bit		0, 1
Integer (Single Word)		-32,768 to 32,767
Integer2 (Double Word)		-2,147,483,648 to 2,147,483,647
Floating Point		-3.4028235E+38 to 3.4028235E+38
HEX (Hexadecimal)		0000h to FFFFh (The HEX data type requires the 'h' after the value.)
Text (Single Character)		Single ASCII character (ASCII code: 00h to FFh.)
ASCII Code		ASCII code \$00 to \$FF (The ASCII Code data type requires the '\$' before the value.)



NOTE: The CLICK PLC does not support Octal or BCD numbering systems (data types).

Memory Types

The following is the list of the memory types that the CLICK PLC system supports. See the memory map later in this chapter.

Memory Type	Symbol	Data Type	S/W Icon	Definition
Input Point	X	Bit		The Discrete Input points are represented by the "X" symbol.
Output Point	Y			The Discrete Output points are represented by the "Y" symbol.
Control Relay	C			The Control Relay bits are represented by the "C" symbol. These internal bits are typically used for ladder program control. They do not represent any real world inputs or outputs.
Timer	T			The Timers are represented by the "T" symbol. The Timer status bit is used to indicate when the Current Value of the timer equals its Preset Value.
Counter	CT			The Counters are represented by the "CT" symbol. The Counter status bit is used to indicate when the Current Value of the counter equals its Preset Value.
System Control Relay	SC			The internal System Control Relays, represented by the "SC" symbol, are pre-defined bits which represent the status of specific system functions.
Data Register	DS	Integer		Single word integer data registers are represented by the "DS" symbol.
	DD	Integer2		Double word integer data registers are represented by the "DD" symbol.
	DH	HEX		Single word Hex data registers are represented by the "DH" symbol.
	DF	Floating Point		Data Floating Point registers are IEEE format Real number values represented by the "DF" symbol as 32-bit words.
Input Register	XD	HEX		The Input Registers, represented by the "XD" symbol, contain groups of Discrete Input points in a 16-bit word format. XD0 is a Hexadecimal representation of X1-X16, XD1 of X101-X116, etc.
Output Register	YD			The Output Registers, represented by the "YD" symbol, contain groups of Discrete Output points in a 16-bit word format. YD0 is a Hexadecimal representation of Y1-Y16, YD1 of Y101-Y116, etc.
Timer Register	TD	Integer		The Timer Registers, represented by the "TD" symbol, contain the corresponding Timer's accumulative value in a 16-bit data register.
Counter Register	CTD	Integer2		The Counter Registers, represented by the "CTD" symbol, contain the corresponding Counter's accumulative value in a 32-bit data register.
System Data Register	SD	Integer		The internal System Data Registers, represented by the "SD" symbol, are pre-defined words which represent the status of specific system functions.
Text	TXT	Text		The Text data registers, represented by the "TXT" symbol, are used to store and manipulate ASCII text data.

Memory Types (cont'd)

Pointer Addressing

The CLICK PLUS PLC allows the use of Pointer Addressing for flexibility in programming. The Copy instruction supports Pointer Addressing in the single copy mode. The Pointer is always assigned as a DS memory type and is designated as a Pointer by placing the DS memory type in square brackets, such as [DS1]. Pointer Addressing uses the Pointer's data value to point to a memory location within the range of one of the eligible memory types. Pointer Addressing can be used with the C, DS, DD, DF, DH, XD, YD, TD, CTD and TXT data register memory types.

Pointer Addressing is also sometimes referred to as Indirect Addressing. One of the many uses for Pointer Addressing would be to perform lookup in tables. An application example might be determining the number of gallons in a horizontal tank when the liquid level is known. The gallons could be determined by a rather complex math formula, but a simpler approach would be to pre-calculate the number of gallons at several uniform levels, and place these values into a table of data registers that can be accessed using Pointer Addressing.

Pointer Addressing Example

DS1 = 100; data register DS1 is assigned the value of 100.

Then the use of DD[DS1] would be the same as showing DD100.

As the value in DS1 is changed, the result would then point to a different DD data register.

In the example, data register DS1 is called a Pointer. Only a DS memory type can be used as a pointer. As mentioned before, the use of the [square brackets] around DS1 in the data register reference DD[DS1] is how the Pointer Addressing is designated.

I/O Numbering System

The CLICK PLC uses decimal numbers for the input (X) and output (Y) addressing.

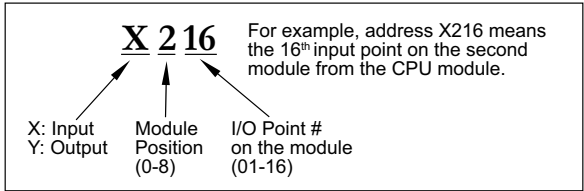

Module Location

Please refer to the following diagram to understand the module position and I/O numbering.

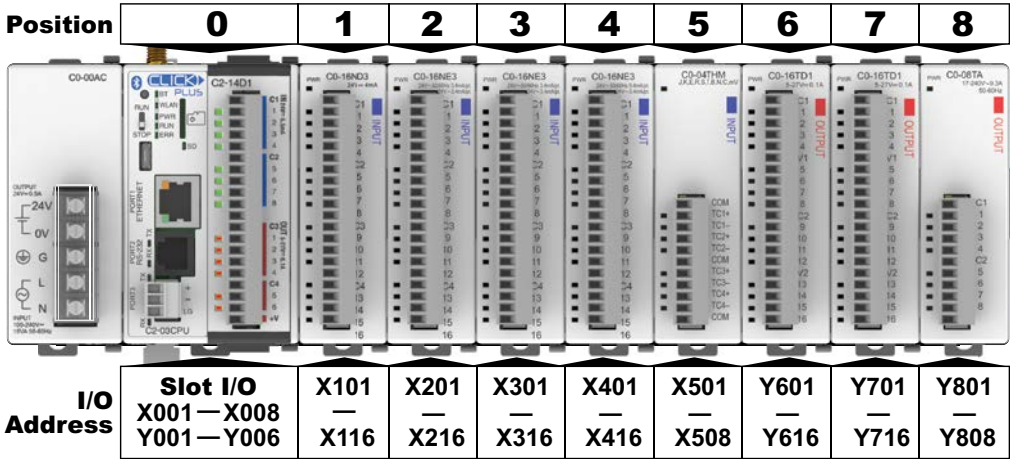

The I/O Addressing can be checked by using the System Configuration window from within the CLICK programming software. From the Setup pulldown menu, select System Configuration; otherwise, from the Navigation window select the Function tab, and under PLC configuration, double click on System Configuration.

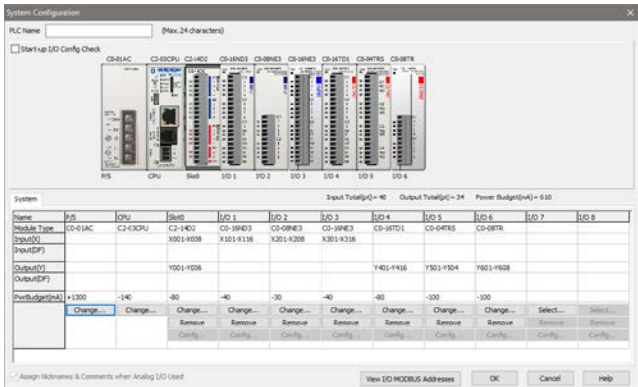

PLC Operation

Introduction

Achieving proper control of your equipment or process requires a thorough understanding of how the CLICK PLUS PLC controls all aspects of system operation. There are three main areas to understand before you create your application program:

- PLC Operating System – the PLC manages all aspects of system control. A quick overview of all the steps are provided in the next section.
- PLC Operating Modes – The two primary modes of operation are Stop mode and Run mode.
- PLC Memory Map – CLICK PLCs offer a wide variety of resources, such as timers, counters, inputs, etc. The Memory Map section shows the organization and availability of these data types.

PLC Operating System

At powerup, the CLICK PLUS PLC initializes the internal electronic hardware. Memory initialization starts with examining the retentive memory settings. In general, the contents of retentive memory are preserved, and non-retentive memory is initialized to zero (unless otherwise specified).

After the one-time powerup tasks, the PLC begins the cyclical scan activity. The flowchart to the right shows how the tasks differ, based on the PLC mode and the existence of any errors. The “scan time” is defined as the average time around the task loop. Note that the PLC is always reading the inputs, even during Stop mode. This allows programming tools to monitor input status at any time.

The outputs are only updated in Run mode. In Stop mode, they are in the off state.

Error detection has two levels. Non-fatal errors are reported, but the PLC remains in its current mode. If a fatal error occurs, the PLC is forced into Stop mode and the outputs turn off.

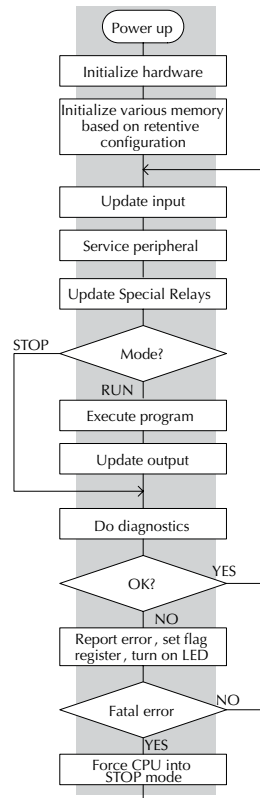

PLC Operating Modes

Stop Mode

In Stop mode, the CLICK PLUS PLC does NOT execute the ladder logic program or update the output points. The primary use for Stop Mode is to enter or change a ladder logic program. You also use Stop mode to set up the PLC parameters, such as retentive memory areas, etc.

You can use CLICK Programming Software, or the CLICK PLUS PLC mode switch to place the PLC in Stop mode; however, the CLICK PLUS PLC mode switch will override the software mode condition. If the PLC mode switch is in the Stop position, the software is blocked from changing the PLC mode. When the PLC mode switch is in the Run position, the software may toggle the mode switch from Run to Stop at will.



Run Mode

In Run mode, the PLC executes the application program and updates the I/O system. You can perform many operations during Run mode. Some of these include:

- Monitor and change I/O point status
- Change timer/counter preset values
- Change variable memory locations

The Run Mode can be divided into several key areas. For the vast majority of applications, some of these execution segments are more important than others. For example, you need to understand how the PLC updates the I/O points, handles forcing operations, and solves the application program. The remaining segments are not that important for most applications.

You can use CLICK Programming Software, or the CLICK PLUS PLC mode switch to place the PLC in Run mode.

Normal Run Mode Scan

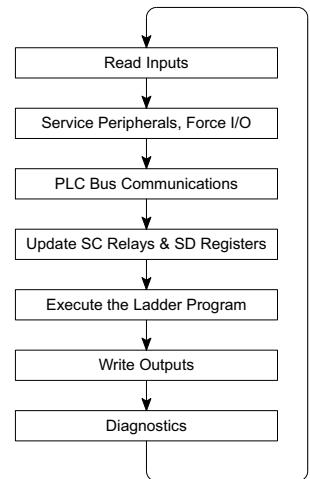

NOTE: The CLICK PLUS PLC will not go into RUN mode if it is in Low Power Mode as a result of powering only through the USB port.



WARNING: Only authorized personnel fully familiar with all aspects of the application should make changes to the ladder logic program. Make sure you thoroughly consider the impact of any changes to minimize the risk of personal injury or damage to equipment.

Read Inputs

The CLICK PLUS PLC reads the status of all inputs, then stores it in the image register. Input image register locations are designated with an X followed by a memory location. Image register data is used by the PLC when it solves the application program.

Of course, an input may change after the PLC has just read the inputs. Generally, the PLC scan time is measured in milliseconds. If you have an application that cannot wait until the next I/O update, you can use Immediate Instructions. These do not use the status of the input image register to solve the application program. The Immediate instructions immediately read the input status directly from the I/O modules. However, this lengthens the program scan since the PLC has to read the I/O point status again.

Service Peripherals and Force I/O

After the CLICK PLUS PLC reads the inputs from the input modules, it reads any attached peripheral devices. This is primarily a communications service for any attached devices. For example, it would read a programming device to see if any input, output, or other memory type status needs to be modified. There are two basic types of forcing available with the CLICK PLC:

- Forcing from a peripheral – not a permanent force, good only for one scan
- Bit Override – holds the I/O point (or other bit) in the current state. Valid bits are X, Y, C, T and CT. (These memory types are discussed in more detail earlier in this chapter).

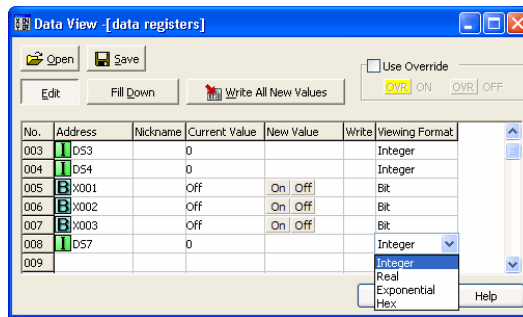

Forcing and Bit Override are done through the Data View Monitor.

Regular Forcing: This type of forcing can temporarily change the status of a discrete bit. For example, you may want to force an input on, even though it is really off. This allows you to change the point status that was stored in the image register. This value will be valid until the image register location is written to during the next scan. This is primarily useful during testing situations when you need to force a bit on to trigger another event.

Bit override: This is a more forceful type of bit manipulation. When bit override is enabled, you can actually override the current status of a bit in the image register. This change will remain intact until you remove the override.



WARNING: Only authorized personnel fully familiar with all aspects of the application should make changes to the program. Make sure you thoroughly consider the impact of any changes to minimize the risk of personal injury or damage to equipment.

Update System Control (SC) Relays and System Data (SD) Registers

The CLICK PLUS PLC units have system memory locations that hold this information. This portion of the execution cycle ensures these locations get updated on every scan. Also, there are several different system control relays, such as diagnostic relays, etc., that are also updated during this segment.

Solve Application Program

The CLICK PLUS PLC evaluates each instruction in the application program during this segment of the scan cycle. The instructions define the relationship between the input conditions and the desired output response. The CLICK PLUS PLC uses the output image register area to store the status of the desired action for the outputs. Output image register locations are designated with a Y followed by a memory location. The actual outputs are updated during the write outputs segment of the scan cycle.

The internal control relays (C) and the data registers (DS, DD, DF and DH) are also updated in this segment.

You may recall that you can force various types of points in the system, discussed earlier in this chapter. If any I/O points or memory data have been forced, the output image register also contains this information.

Write Outputs

Once the application program has solved the instruction logic and constructed the output image register, the CLICK PLC writes the contents of the output image register to the corresponding output points. Remember, the PLC also ensured that any forcing operation changes were stored in the output image register, so the forced points get updated with the status specified earlier.

Diagnostics

During this part of the scan, the PLC performs all system diagnostics and other tasks such as calculating the scan time and resetting the watchdog timer. There are many different error conditions that are automatically detected and reported by the CLICK PLUS PLC. Chapter 6: *Troubleshooting* contains a listing of the various error codes with a description of the possible causes.

Probably one of the more important things that occurs during this segment is the scan time calculation and watchdog timer control. The CLICK PLUS PLC has a watchdog timer that stores the maximum time allowed for the PLC to complete the solve application part of the scan cycle. If this time is exceeded, the PLC will enter the Stop mode and turn off all outputs. An error is automatically reported. The default value of the watchdog timer is 200ms and can be adjusted between 5–10,000 ms. Refer to the online help available from the CLICK Programming Software, C0-PGMSW, for additional information in regards to the Watchdog Timer.

Accessories

C2-USER-M – CLICK PLUS PLC Hardware Users Manual



Manual covers all CLICK PLUS PLC & I/O Module installation & wiring, specifications, error codes & trouble shooting guide. The CLICK PLUS PLC Hardware User Manual can be downloaded free at the AutomationDirect Web site, www.automationdirect.com

C0-PGMSW – CLICK PLC Programming Software USB



CLICK PLC programming software Ladder Logic Editor for Windows PCs, includes the manual as a pdf file. Free download available from AutomationDirect online Web store: www.automationdirect.com. Alternatively the programming software USB may be purchased and shipped from the AutomationDirect online Web store: www.automationdirect.com

USB-CBL-AMICB6 – USB A to USB micro B Programming Cable Assembly



Programming cable, USB A to micro-B USB, 6ft cable length. For use with Productivity1000 and Productivity2000 CPUs, CLICK PLUS CPUs and most USB devices. The USB port supplies 5VDC to the CLICK PLUS CPU for programming.

EA-MG-PGM-CBL – PC to Panel Programming Cable Assembly for C-more Micro-Graphic Panels and CLICK/CLICK PLUS PLCs



6-ft cable assembly connects a personal computer to any C-more Micro-Graphic panel, CLICK PLC, or select CLICK PLUS PLC for setup and programming. Assembly includes standard USB A-type connector to B-type connector cable, custom converter, and a RS232C cable with RJ12 modular connector on each end

D2-DSCBL – PC Programming Cable for CLICK and *Direct*LOGIC PLCs



12ft (3.66 m) RS232 shielded PC programming cable for CLICK, DL05, DL06, DL105, DL205, D3-350, and D4-450 CPUs. 9-pin D-shell female connector to an RJ12 6P6C connector.

Cat5e – PC Programming Ethernet Cable for CLICK PLCs



3ft–50ft Cat5e STP Ethernet Patch Cable for PC programming of CLICK PLCs; RJ45 connector. Straight or Cross-over cable can be used.

Accessories (cont'd)



C2-FILL
CPU Option Slot Cover

Snap-on cover for CPU Option Slot in applications without an Option Slot module present.



MSD-SLC16G

16GB microSD card, industrial grade, 3D NAND Flash (with SLC Mode), 85°C [185°F] max operating temp.



SE-ANT210

Whip/straight 2.4 GHz antenna, IP65, connector mount.



SE-ANT250

Dome 2.4 GHz antenna, IP67, panel mount, 9.8ft/3m cable length.

2.4 GHz WiFi Antenna Specifications		
	SE-ANT210	SE-ANT250
Antenna Connector	RP-SMA (M)	
Application	WLAN (802.11 b/g/n), Bluetooth (IEEE 802.15.1)	
Impedance	50Ω	
Antenna Type	whip, straight	dome
Cable Length	N/A	3m [9.8 ft]
Frequency Range	2.4-2.5 GHz	
Gain	1.8 dBi	1.5 dBi
Height	1.2 in	1.89 in
IP Rating	IP65	IP67
Maximum Power	1W	5W
Mounting Screw Torque	NA	2.94 N·m

Accessories (cont'd)

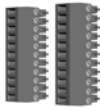

C0-8TB – Spare 8 Point I/O Terminal Block

Replacement terminal block for the 8 point I/O modules. Sold in packs of 2.

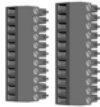

C0-8TB-1 – Spare 8 Point I/O Terminal Block

Replacement terminal block for the 8 point relay I/O modules. Sold in packs of 2.

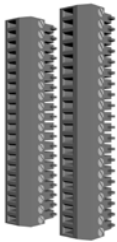

C0-16TB – Spare 16 Point I/O Terminal Block

Replacement terminal block for the 16 point I/O modules & Option Slot I/O. Sold in packs of 2.



C0-3TB - Spare 3-Pole Terminal Block

Replacement 3-pole terminal block for the 3-wire, RS485 communications port on the C2-03CPU and C2-03CPU-02 PLCs. Sold in packs of 2.



C0-4TB – Spare 24VDC Power Terminal Block

Replacement terminal block for the 24VDC supply power to the PLC. Sold in packs of 2.



C2-6TB - Spare 6-Pole Terminal Block

Replacement 6-pole terminal block for the C2-DCM. Sold in packs of 2.



D0-MC-BAT – Battery

Replacement battery for CLICK PLUS PLC units.

ZIPLink Wiring Systems

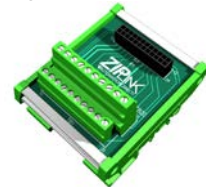

C-more and C-more Micro-Graphic Operator Interfaces



DN-WS – Wire Stripper



TW-SD-MSL-2 – Insulated Slotted Screwdriver 0.4 x 2.5 x 80 mm



DN-EB35MN – DINnectors End Bracket



INSTALLATION AND WIRING



In This Chapter...

Safety Guidelines.....	3-2
Introduction to the CLICK PLUS PLC Mechanical Design.....	3-5
Mounting Guidelines	3-10
Installing the CLICK PLUS PLC	3-20
Wiring Guidelines.....	3-22
I/O Wiring Checklist	3-30
System Wiring Strategies	3-31
LAN Provisioning over Bluetooth	3-42
Option Slot Analog I/O Configuration.....	3-46
High-Speed Input/Output Configuration.....	3-53
Setting Up and Using an SD Card.....	3-58

Safety Guidelines



NOTE: Products with CE marks perform their required functions safely and adhere to relevant standards as specified by CE directives, provided they are used according to their intended purpose and that the instructions in this manual are followed. The protection provided by the equipment may be impaired if this equipment is used in a manner not specified in this manual. A listing of our international affiliates is available on our Web site at <http://www.automationdirect.com>.



WARNING: Providing a safe operating environment for personnel and equipment is your responsibility and should be your primary goal during system planning and installation. Automation systems can fail and may result in situations that can cause serious injury to personnel or damage to equipment. Do not rely on the automation system alone to provide a safe operating environment. You should use external electromechanical devices, such as relays or limit switches, that are independent of the PLC application to provide protection for any part of the system that may cause personal injury or damage. Every automation application is different, so there may be special requirements for your particular application. Make sure you follow all national, state, and local government requirements for the proper installation and use of your equipment.

Plan for Safety

The best way to provide a safe operating environment is to make personnel and equipment safety part of the planning process. You should examine every aspect of the system to determine which areas are critical to operator or machine safety. If you are not familiar with PLC system installation practices, or your company does not have established installation guidelines, you should obtain additional information from the following sources.

- NEMA — The National Electrical Manufacturers Association, located in Washington, D.C., publishes many different documents that discuss standards for industrial control systems. You can order these publications directly from NEMA. Some of these include:
 - ICS 1, General Standards for Industrial Control and Systems
 - ICS 3, Industrial Systems
 - ICS 6, Enclosures for Industrial Control Systems
- NEC — The National Electrical Code provides regulations concerning the installation and use of various types of electrical equipment. Copies of the NEC Handbook can often be obtained from your local electrical equipment distributor or your local library.
- Local and State Agencies — many local governments and state governments have additional requirements above and beyond those described in the NEC Handbook. Check with your local Electrical Inspector or Fire Marshall office for information.

Three Levels of Protection



WARNING: The control program must not be the only form of protection for any problems that may result in a risk of personal injury or equipment damage.

The publications mentioned provide many ideas and requirements for system safety. At a minimum, you should follow these regulations. Also, you should use the following techniques, which provide three levels of system control.

1. Orderly system shutdown sequence in the PLC control program
2. Mechanical disconnect for output module power
3. Emergency stop switch for disconnecting system power

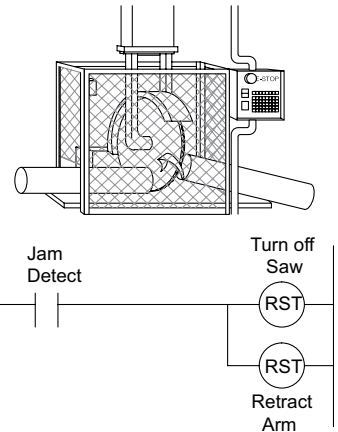

Orderly System Shutdown

The first level of fault detection is ideally the PLC control program, which can identify machine problems. These types of problems are usually things such as jammed parts, etc., that do not pose a risk of personal injury or equipment damage. However, respective shutdown sequences should be performed.

System Power Disconnect

You should also use electromechanical devices, such as master control relays and/or limit switches, to prevent accidental equipment startup at an unexpected time. These devices should be installed in a manner that will prevent any machine operations from occurring.

For example, if the machine in the illustration has a jammed part, the PLC control program can turn off the saw blade and retract the arbor. If the operator must open the guard to remove the part, you should also include a bypass switch that disconnects all system power any time the guard is opened.

Emergency Stop Circuits

Emergency stop (E-Stop) circuits are a critical part of automation safety. For each machine controlled by a PLC, provide an emergency stop device that is wired outside the PLC and easily accessed by the machine operator.

E-stop devices are commonly wired through a master control relay (MCR) or a safety control relay (SCR) that will remove power from the PLC I/O system in an emergency.

MCRs and SCRs provide a convenient means for removing power from the I/O system during an emergency situation. By de-energizing an MCR (or SCR) coil, power to the input (optional) and output devices is removed. This event occurs when any emergency stop switch opens. However, the PLC continues to receive power and operate even though all its inputs and outputs are disabled.

The MCR circuit could be extended by placing a PLC fault relay (closed during normal PLC operation) in series with any other emergency stop conditions. This would cause the MCR circuit to drop the PLC I/O power in case of a PLC failure (memory error, I/O communications error, etc.).

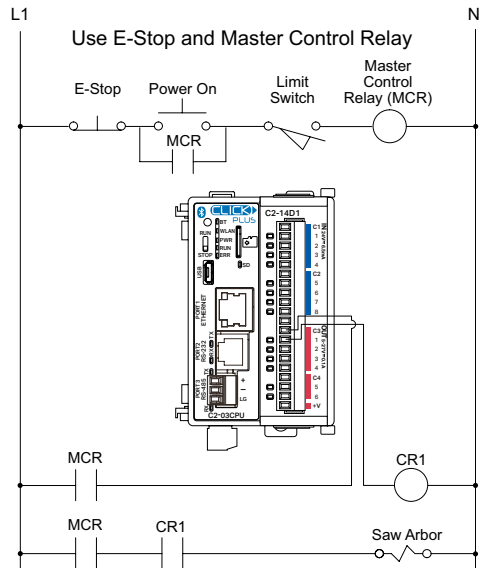
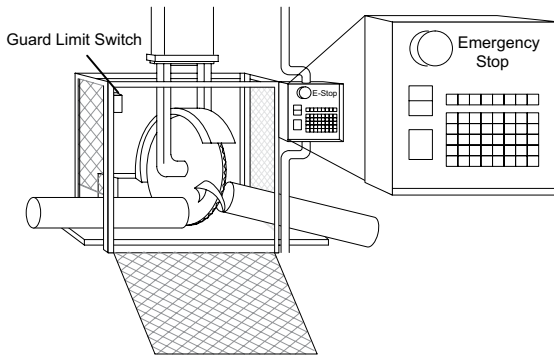

WARNING: For some applications, field device power may still be present on the terminal block even though the PLC is turned off. To minimize the risk of electrical shock, remove all field device power before you expose or remove PLC wiring. The connector is designed for easy removal by hand.

Introduction to the CLICK PLUS PLC Mechanical Design

CLICK PLUS PLC Units

All CLICK PLUS PLCs are similar in appearance. Please see the diagrams below to familiarize yourself with the PLC features. The main components located on the front of the PLC are a Run/Stop switch, communications ports, micro SD card slot, LED status indicators and the Option Slot expansion port. A removable 4-pin 24VDC input power connector is located on the bottom of the PLC. Some models include an RP-SMA antenna port on the top of the PLC. The I/O module extension port is located on the right side of the PLC case. See Mounting Guidelines in this chapter for module dimensions and Chapter 2 for CLICK PLUS PLC specifications.

Component Locations on CLICK PLUS PLC Units

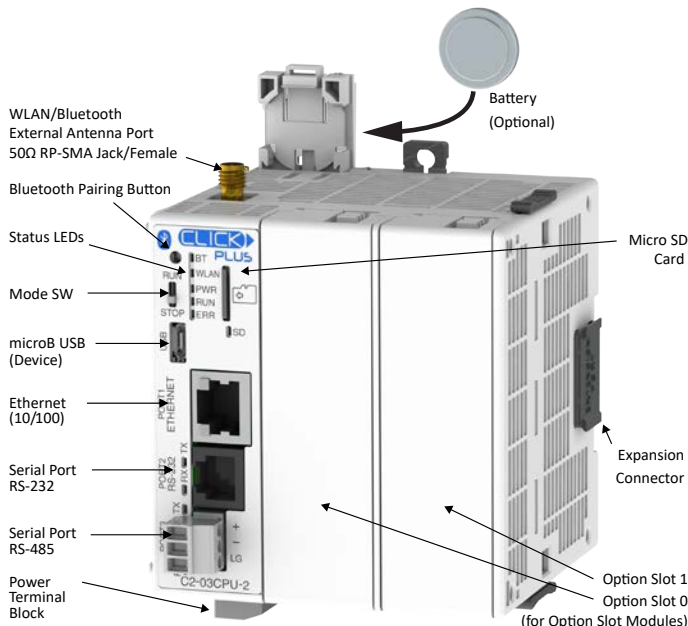

NOTE: High-speed Inputs and Outputs are only available on Slot 0.

CPU is shown with optional C2-FILL Option Slot Covers installed.

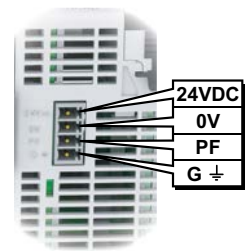

Bottom view same for all PLC's

CLICK PLUS Option Slot Modules

All CLICK PLUS PLCs include one or two built-in expansion slots, designated Option Slots. The first Option Slot (Slot 0) has access to the PLC's high-speed bus. Three Intelligent Module and seventeen different Option Slot I/O modules are available, divided into five types, as shown below.

Discrete input sections of the modules are identified with a blue bar, and discrete output sections are identified with a red bar. Analog input and output terminals are identified by "AD" and "DA" prefixes to the terminal names, respectively.

See Mounting Guidelines in this chapter for module dimensions and Chapter 2 for CLICK Option Slot module specifications.

<i>Discrete I/O Modules</i>	<i>Discrete & Analog I/O</i>			<i>Intelligent Modules</i>
	<i>Current I/O Modules</i>	<i>Voltage I/O Modules</i>	<i>Current/Voltage I/O Modules</i>	
C2-14D1	C2-08D1-6C	C2-08D1-6V	C2-08D1-4VC	C2-DCM
C2-14D2	C2-08D2-6C	C2-08D2-6V	C2-08D2-4VC	C2-NRED
C2-14DR	C2-08DR-6C	C2-08DR-6V	C2-08DR-4VC	C2-OPCUA
C2-14AR	C2-08AR-6C	C2-08AR-6V	C2-08AR-4VC	
C2-14TTL				

CLICK I/O Modules

All CLICK PLC system input and output modules are compatible with the CLICK PLUS PLC. Several different types of I/O modules are available. Please see the diagrams below to familiarize yourself with the I/O module features.

Each I/O module is identified as an Input or Output module on its front panel using the color coding scheme listed below. Up to eight I/O option modules can be connected to a CLICK PLC. See Mounting Guidelines in this chapter for module dimensions and Chapter 2 for CLICK I/O module specifications.

Input Modules

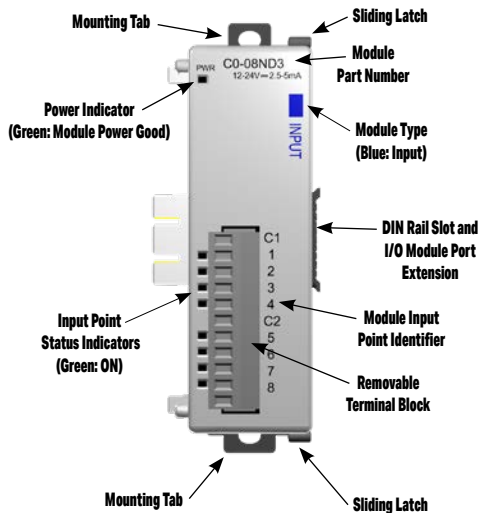

Output Modules

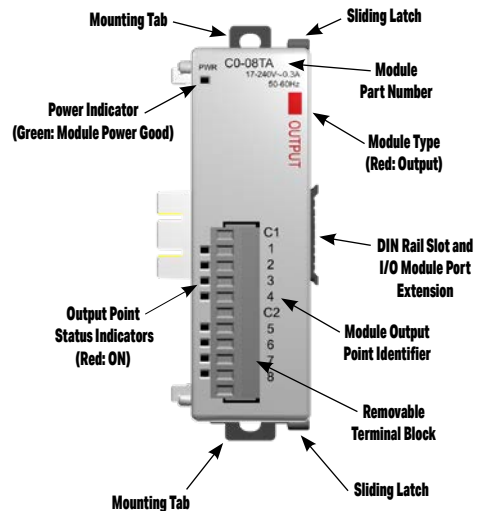

CLICK Power Supplies

All CLICK PLUS PLCs require 24VDC input power from either a CLICK power supply or other suitable external power supply. Two models of CLICK power supplies are available to supply power to the PLC and I/O modules.

- C0-00AC - 0.5 A @ 24VDC output
- C0-01AC - 1.3 A @ 24VDC output

Select a power supply based on the power requirements of your system components. See Mounting Guidelines in this chapter for module dimensions and Chapter 2 for CLICK power supply specifications.

Power wires must be connected from the output terminals on the front of the power supply to the input power connector on the bottom of the CLICK PLUS PLC (There is no internal 24VDC power bus to the PLC.) See Mounting Guidelines for additional wiring information.

Only a single CLICK power supply can be attached directly to a CLICK PLUS PLC system. If multiple CLICK power supplies are used, or if other type of power supplies are used, mount them separately from the PLC. For example, the PSP24-DC12-1 DC-DC converter shown below must be mounted separately from the PLC.

C0-00AC and C0-01AC Power Supplies Component Locations

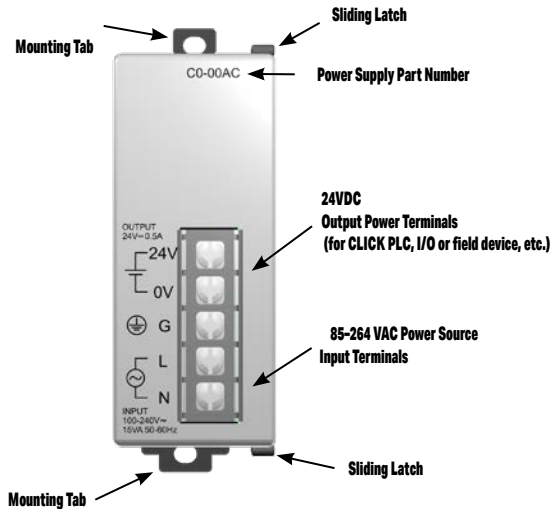

The PSP24-DC12-1 DC-DC converter must be mounted separately from the PLC.

Battery Backup

All of the CLICK PLUS PLC units have a super capacitor to maintain back up data in SRAM. The super capacitor should maintain a backup period of at least 1 hour.

If you need the CLICK PLC unit to maintain data in the SRAM for longer than the above period after the power is shut off, you must install a battery in the CLICK PLC unit.

Use battery part number D0-MC-BAT (not included with the PLC unit; order battery separately). Typical battery life is about 3 years, which includes PLC runtime and normal shutdown periods.



NOTE: Please power off the PLC while installing and/or changing the battery.

To install or replace the D0-MC-BAT battery:

1. Power up the CPU for at least 10 minutes to charge the CPU's capacitor prior to removing the battery. This will retain function memories. We recommend you backup data memory before replacing the battery. Plan to complete the battery replacement within 10 minutes of power off.
2. Power off the CPU.
3. Pull out the battery holder. (This may require a small screwdriver to push in the tab and lift it when the unit is mounted.)
4. Put in a new battery, with the positive (+) polarity side facing the battery holder.
5. Insert the battery holder into the CPU and push it all the way in.
6. Power on the CPU.
7. Make a note of the date the battery was installed. (Battery life is about 3 years.)



The battery backup is now available.



WARNING: Do not attempt to recharge the battery or dispose of it by fire. The battery may explode or release hazardous materials.



TIP: The CLICK PLUS PLC has a feature that indicates the pre-scheduled battery replacement date has passed. In the CLICK programming software, go to the pull-down menu: Setup > Battery backup Setup.

Mounting Guidelines

Environmental Specifications

The CLICK family of PLC products should be stored, installed, and used within their range of environmental specifications, such as storage temperature, operating temperature, humidity, environmental air, vibration, shock, and noise immunity. Certain output module circuit types may have derating curves depending on the ambient temperature and the number of outputs ON. Refer to the I/O module specifications in Chapter 2: *Specifications* for CLICK PLUS PLC environmental specifications and I/O module derating curves.

Agency Approvals

In addition to the panel layout guidelines, other specifications can affect the definition and installation of a PLC system. Always consider the following:

- Environmental Specifications
- Power Requirements
- Agency Approvals
- Enclosure Selection and Component Dimensions

CLICK Unit Dimensions

The following diagrams illustrate the dimensions of the CLICK power supply, CLICK PLUS PLC, Option Slot I/O modules and Stackable I/O modules. The CLICK PLC system is designed to be mounted on standard 35mm DIN rail, or it can be surface mounted. See the following pages for installations and mounting information, including “Mounting CLICK PLUS PLC System on DIN Rail” on page 3-21 for DIN rail and surface-mounting instructions.

Power Supply

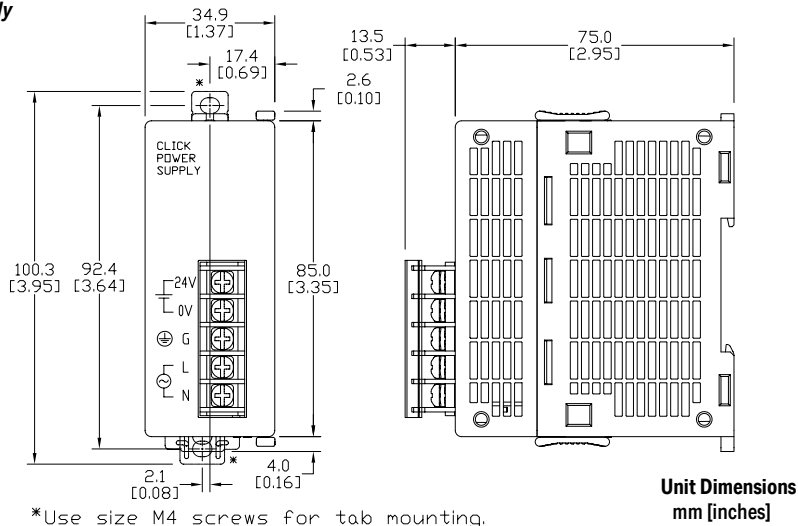

NOTE: The dimensions for the C0-00AC and C0-01AC power supplies are the same.



PLC Unit, C0-Series and Single-slot C2-Series

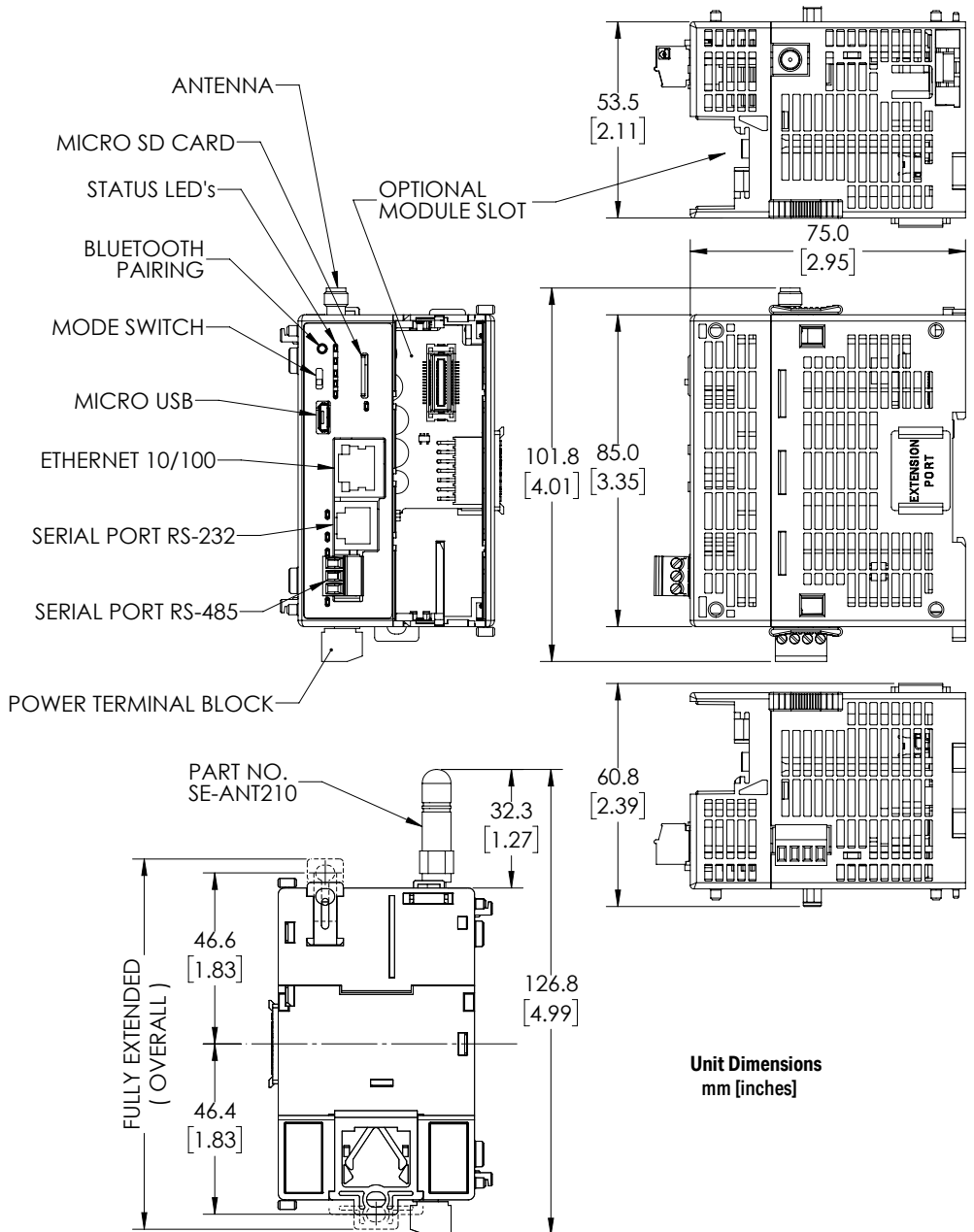

Chapter 3: Installation and Wiring

PLC Unit, Dual-slot C2-Series

Unit Dimensions mm [inches]

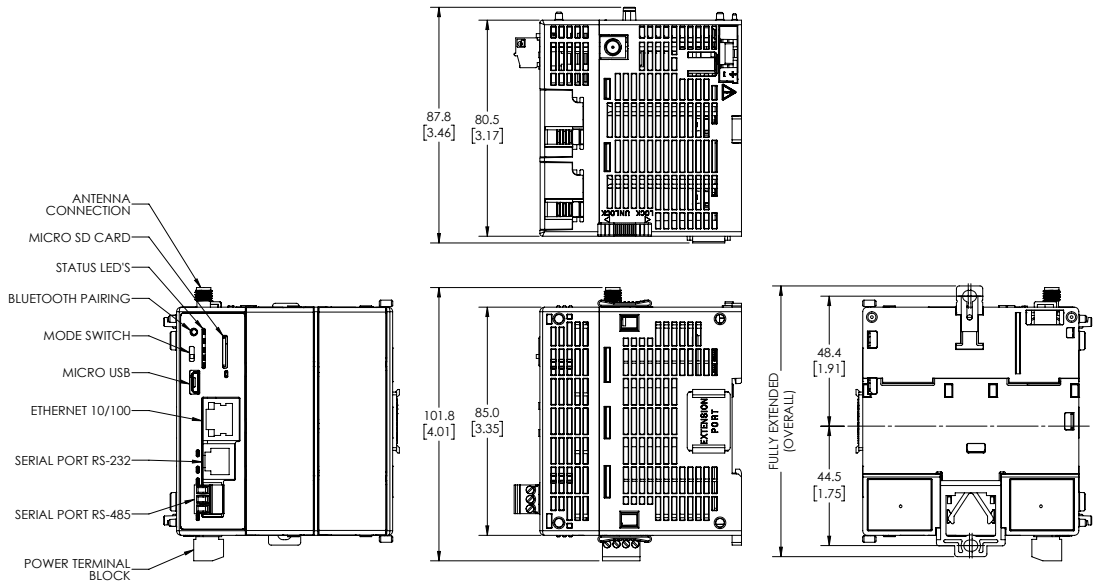

Option Slot I/O Modules

Unit Dimensions
mm [inches]

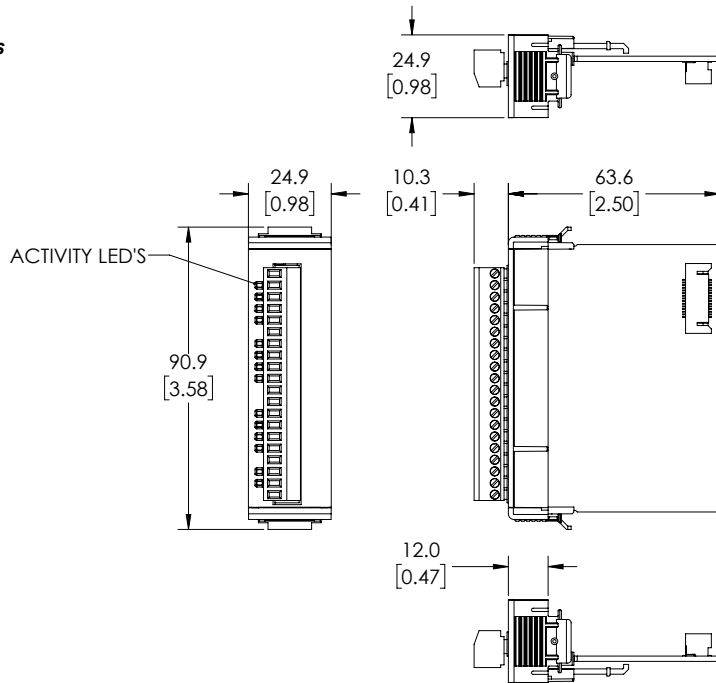

Option Slot C2-DCM Module

Unit Dimensions
mm [inches]

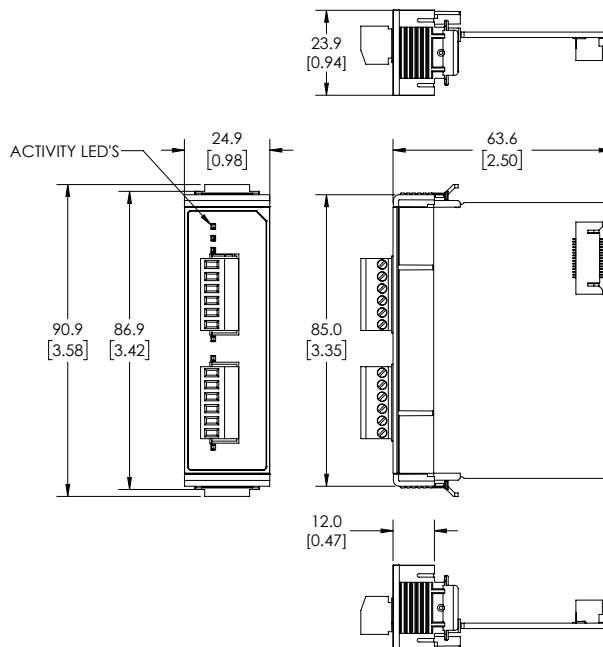

Chapter 3: Installation and Wiring

Option Slot C2-NRED and C2-OPCUA Modules

Unit Dimensions mm [inches]

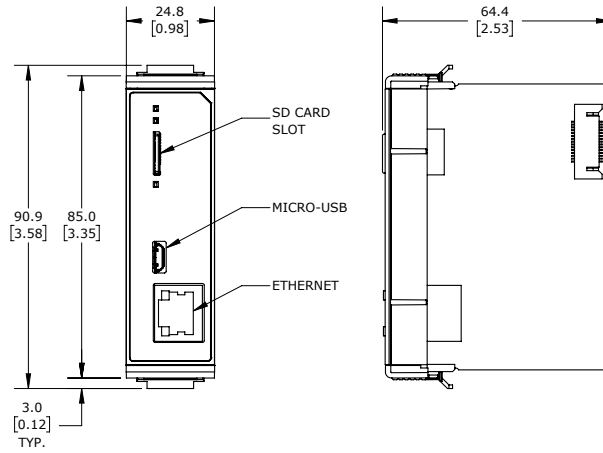

Stackable I/O Module

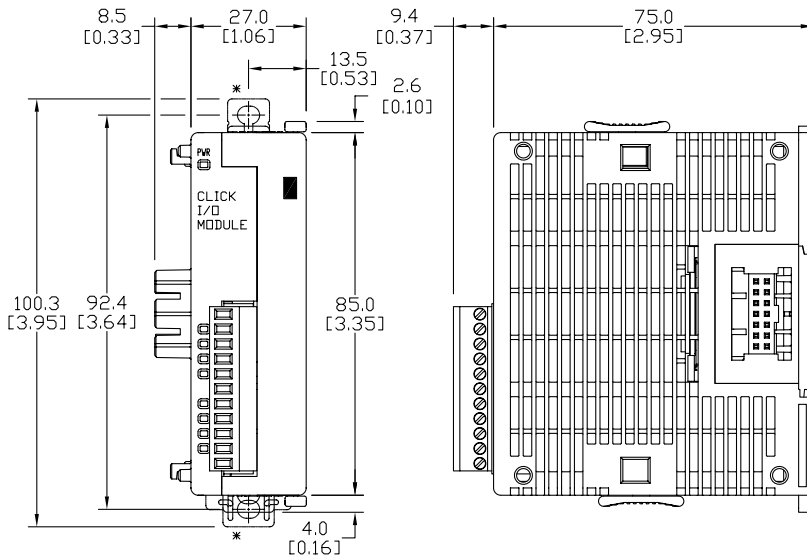

*Use size M4 screws for tab mounting.

Unit Dimensions
mm [inches]

Stackable C0-04POT Module

Unit Dimensions
mm [inches]

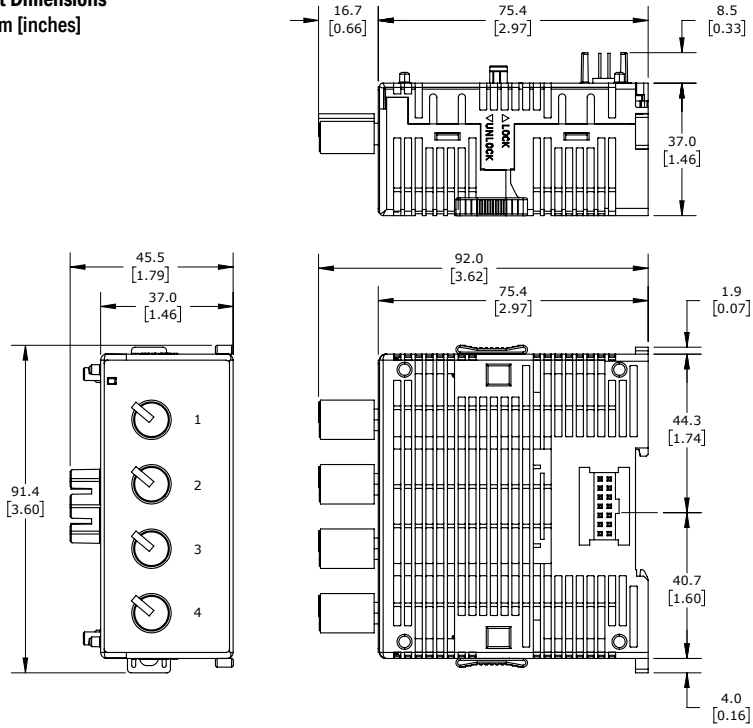

Chapter 3: Installation and Wiring

PLC Unit System

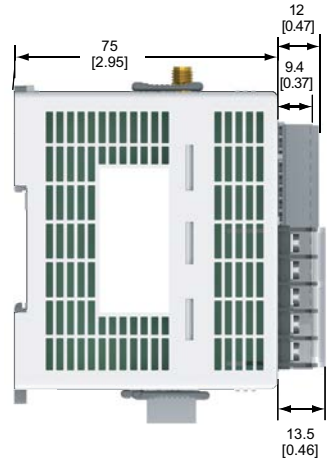
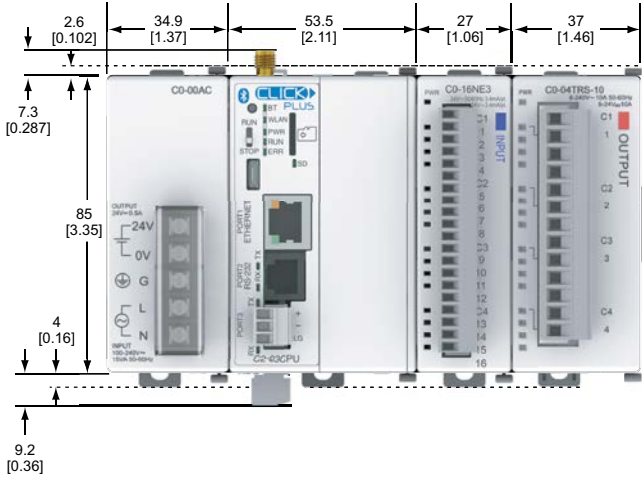

Unit Dimensions
mm [inches]

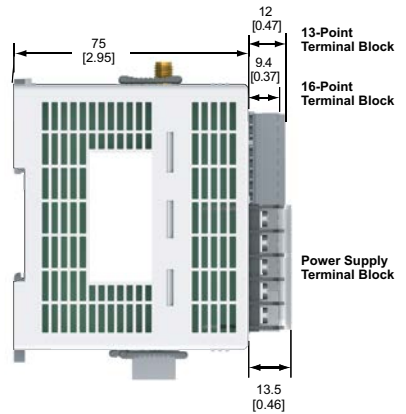
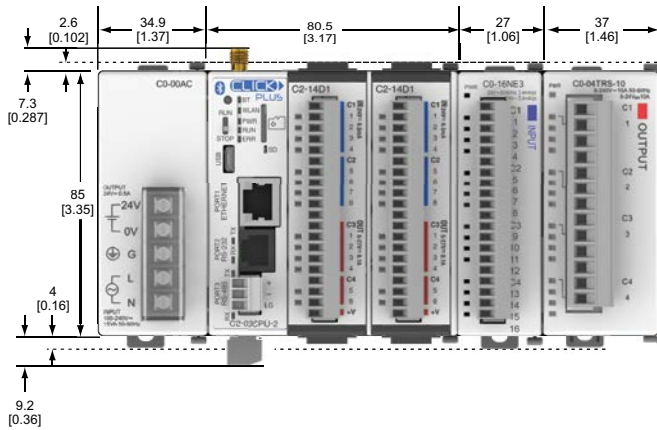

Maximum system: Power Supply + PLC + eight I/O modules.

Follow the installation guidelines to allow for proper spacing from other components within an enclosure. Note that the relay Stackable modules are each about 10mm wider than non-relay Stackable modules. The diagrams below indicate maximum system width with 8 relay modules and with 8 non-relay modules.

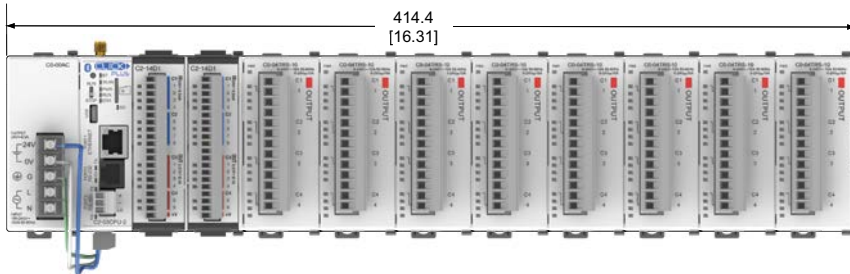
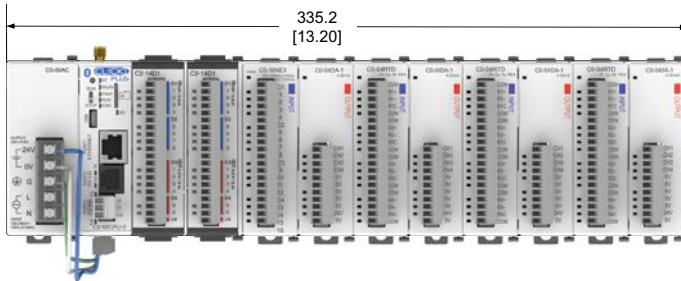
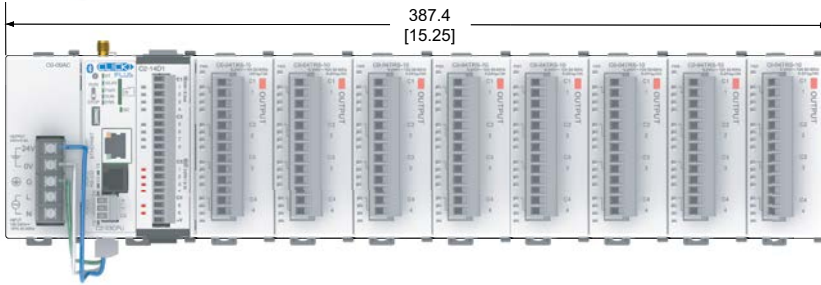
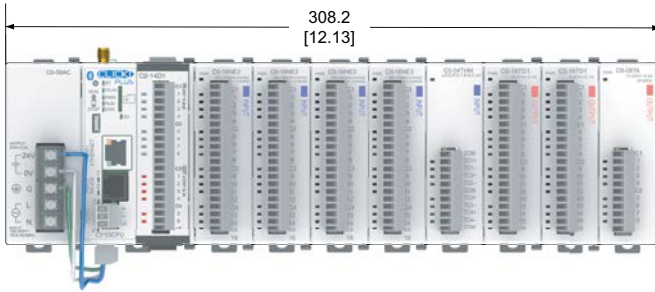

Enclosures

Your selection of a proper enclosure is important to ensure safe and proper operation of your CLICK PLUS PLC system. Control applications vary and yours may require additional considerations. At a minimum your enclosure should include:

- Conformance to electrical standards
- Protection from the elements in an industrial environment
- Common ground reference
- Maintenance of specified ambient temperature
- Access to equipment
- Security or restricted access
- Sufficient space for proper installation and maintenance of equipment

Panel Layout and Clearances

1. Mount the CLICK PLUS PLC unit (system) horizontally as shown below to provide proper ventilation. Do not mount the CLICK PLUS PLC units upside down, on a horizontal surface or in a vertical arrangement. If you place more than one unit in a cabinet, there must be a minimum of 7.2" (183mm) between the units.

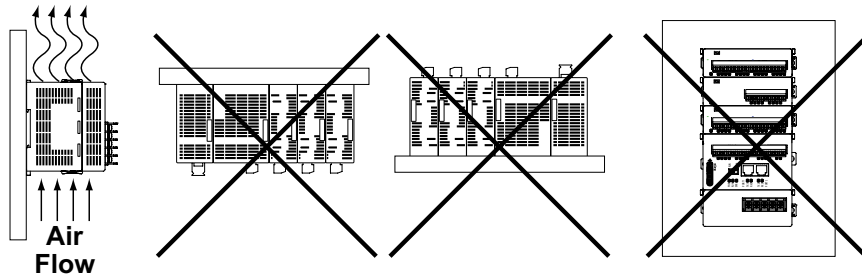

2. Provide a minimum clearance of 2" (50mm) between the unit and all sides of the cabinet.
NOTE: Remember to allow clearance for any operator panels or other items mounted directly in front of the unit in the door.
3. There should also be at least 3" (78mm) of clearance between the unit and any wiring ducts that run parallel to the terminals.
4. The ground terminal on the CLICK PLUS PLC must be connected to a single point ground. Use copper stranded wire to achieve a low impedance. Copper eye lugs should be crimped and soldered to the ends of the stranded wire to ensure good surface contact.
5. There must be a single point ground (i.e. copper bus bar) for all devices in the panel requiring an earth ground return. The single point of ground must be connected to the panel ground termination. The panel ground termination must be connected to ground. Minimum wire sizes, color coding, and general safety practices should comply with appropriate electrical codes and standards for your area.

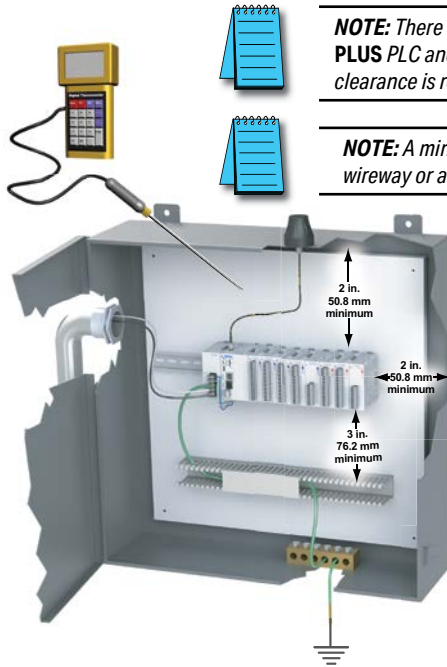

NOTE: There is a minimum clearance requirement of 2" (51mm) between the **CLICK PLUS PLC** and the panel door or any devices mounted in the panel door. The same clearance is required between the PLC and surrounding enclosure.

NOTE: A minimum clearance of 3" (76mm) is required between the PLC and a wireway or any heat producing device.

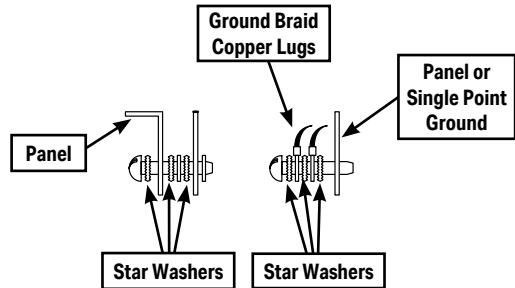

6. A good common ground reference (Earth ground) is essential for proper operation of the CLICK PLUS PLC. One side of all control and power circuits and the ground lead on flexible shielded cable must be properly connected to Earth ground. There are several methods of providing an adequate common ground reference, including:
 - a) Tying to a ground rod installed as close as possible to the panel
 - b) Connection to incoming power system ground
7. Evaluate any installations where the ambient temperature may approach the lower or upper limits of the specifications. If you suspect the ambient temperature will not be within the operating specification for the CLICK PLUS PLC system, measures such as installing a cooling/heating source must be taken to get the ambient temperature within the range of specifications.
8. CLICK PLUS PLC systems are modular and can be powered by any suitable 24VDC power supply. The optional CLICK power supply is designed to attach to the left side of the CLICK PLUS PLC case. CLICK power supplies accept 85-264 VAC and produce nominal 24VDC to power the CLICK PLUS PLC and I/O modules. Powerline filters are recommended for protecting the CLICK PLUS PLC from power surges and EMI/RFI noise. The AutomationDirect Powerline Filter, for use with 120VAC and 240VAC, 1-5 Amps, is an excellent choice (locate at www.automationdirect.com), however, you can use a filter of your choice. The filter units install easily between the AC power source and the PLC.

Installing the CLICK PLUS PLC

Installing Option Slot Modules



NOTE: Option Slot Intelligent Modules may require a firmware update on the PLC **before** installing the module. Check Chapter 5 of this manual or the module's installation documentation for any firmware version requirements..

1. Locate the card guides inside the slot.
2. Slide the Option Slot Module into slot ensuring the card falls into the slots.
3. Press the Option Slot Module down to seat the card.
4. Snap the locking tabs down into place.



Step 1



Step 2

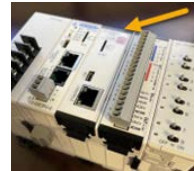

Step 3



Step 4

Connecting the Modules Together

CLICK PLUS PLCs and I/O modules connect together using the Extension Ports that are located on the side panels of the modules. The modules secure together by sliding LOCK/UNLOCK latch tabs located on the top and bottom panels of the modules. A PLC backplane or base is not required.

When connecting an I/O module to the PLC, first remove the Extension Port covers, slide the latches forward (unlock), align the module pins, and press the I/O module onto the PLC's right side. Slide the latches backward to lock the modules together.



NOTE: If you are using other components in your system, make sure you refer to the appropriate manual to determine how those units can affect mounting dimensions.

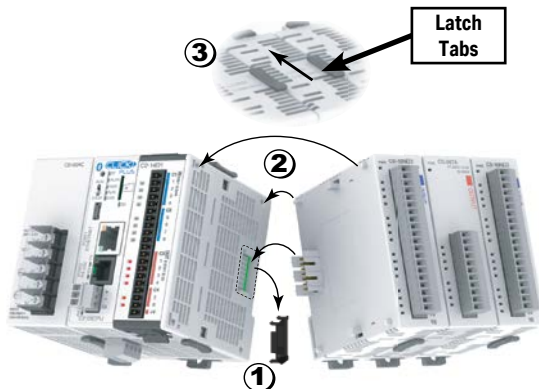

- 1) Remove extension port covers and slide latch tabs forward.
- 2) Align the module pins and connection plug, and press the I/O module onto the right side of the PLC.
- 3) Slide the latch tabs backward to lock the modules together.

Mounting CLICK PLUS PLC System on DIN Rail

CLICK PLUS PLCs can be secured to a panel by using mounting rails. We recommend rails that conform to DIN EN standard 50 022. They are approximately 35mm high, with a depth of 7mm. If you mount the CLICK PLUS PLC on a rail, consider using end brackets on each side of the PLC. The end bracket helps keep the PLC from sliding horizontally along the rail, reducing the possibility of accidentally pulling the wiring loose. On the bottom of the PLC is a small retaining clip. To secure the PLC to a DIN rail, place it onto the rail and gently push up on the clip to lock it onto the rail. To remove the PLC, pull down on the retaining clip, lift up on the PLC slightly, then pull it away from the rail.

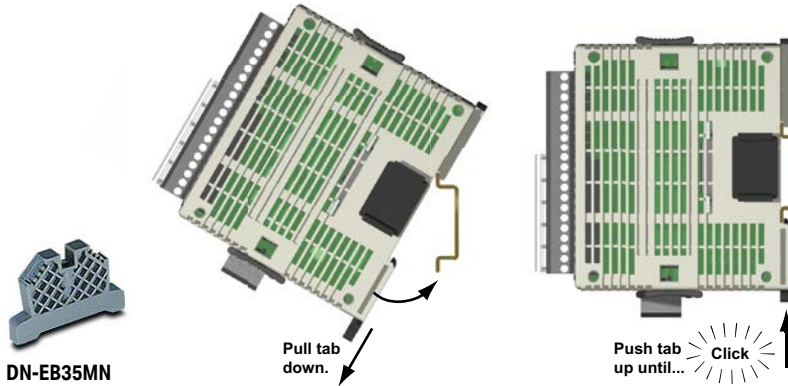

NOTE: When mounting on DIN rail, using DINnectors end brackets at both ends is recommended (part number DN-EB35MN).

Optional Mounting Method

The CLICK PLUS PLC system can be secured to the equipment panel or desired location using the mounting tabs located on the back panel of the PLC, I/O modules and power supplies. Extend the upper and lower retaining clips to the full out position. Mount using M4 screws in the center hole of the tabs.

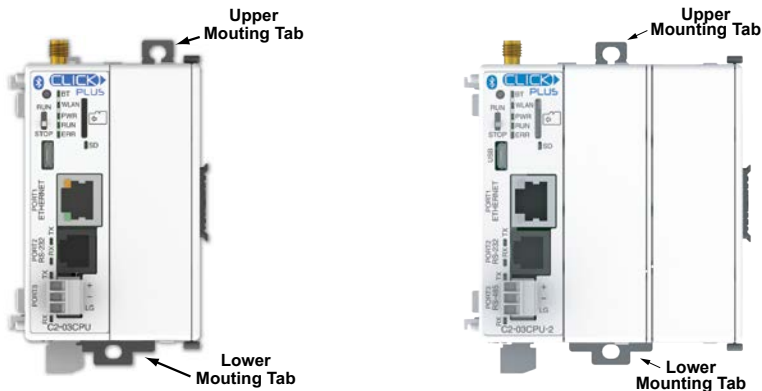

Wiring Guidelines

Power Input Wiring to Click Power Supply

Connect the AC power source input wiring to the CLICK power supply (the CLICK power supply voltage and current requirements are listed in chapter 2). If you are not using a CLICK power supply, be sure that it meets CLICK PLUS PLC requirements.

Do not apply power at this time. Observe all precautions stated earlier in this manual.



WARNING: Once the power wiring is connected, secure the terminal block cover in the closed position. When the cover is open there is a risk of electrical shock if you accidentally touch the connection terminals or power wiring.

Power Input Wiring to CLICK PLUS PLC

Connect the 24VDC power source input wiring to the 4-pin 24VDC input connector located on the bottom panel of the CLICK PLUS PLC. Do not apply power at this time. Observe all precautions stated earlier in this manual.

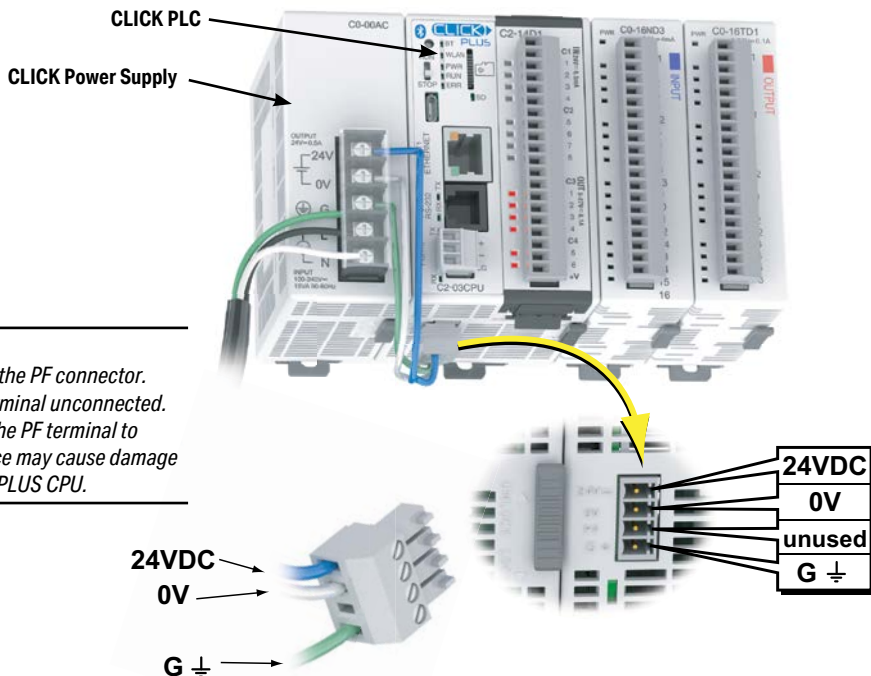

CAUTION:
DO NOT USE the PF connector.
Leave this terminal unconnected.
Connecting the PF terminal to
another device may cause damage
to the CLICK PLUS CPU.

Power Input Wiring to CLICK PLUS PLC, continued

Power Terminal Wiring Specifications	
Terminal Type	3.5 mm pitch pluggable terminal block
Wire Range	16–28 AWG
Wire Strip Length	7.0 mm
Wire Specification	Supported temperature: > 60°C Material: Copper
Screw Torque	2.0–2.2 lb-inch [0.22–0.25 N·m]
Screw Size	M2
Number of Pins	4-pin terminal block
Screwdriver Size	DN-SS1 or compatible (insulated slotted screwdriver 0.4 x 2.5 x 75 mm)

Note: C0-00AC or C0-01AC Power Supply recommended.

Power Terminal Pinout	
24V	24V Power supply in
0V	0V Power supply reference
PF	unused
G	Ground



USB Low Power Mode

The CLICK PLUS PLC can be powered over its USB port when no 24VDC power is applied. The following capabilities and restrictions apply to USB Low Power Mode.

Available:

- Programming over Ports 1, 2 and 3
- Firmware update
- CLICK Factory Default and CLICK Project Loader Tools
- Modbus Server/Slave over Ports 1, 2 and 3
- Option Slot module can be identified in software

Not Available:

- Not available when C2-NRED or C2-OPCUA modules are installed
- RUN mode is disabled
- WLAN and Bluetooth are disabled
- Access to the microSD Card from software is disabled
- Stackable I/O modules cannot be identified in software.



Fuse Protection

Fuse Protection for PLC Input Power

External circuit protection is needed to ensure the safety of service personnel and the safe operation of the equipment itself. To meet UL/CUL specifications, the input power must be fused. Fuse the AC side of the power supply that provides the 24VDC power to the CLICK PLC.

When operating the power supply from a 110/120 VAC system with a grounded neutral, it is only necessary to fuse the line (L) lead; it is not necessary to fuse the grounded neutral (N) lead. Select the fuse size based on the input current draw of the power supply. Refer to Chapter 2 of this manual for specifications of CLICK power supplies.

Fuse Protection for I/O Module Circuits

Input and Output circuits on CLICK PLUS PLCs do not have internal fuses. In order to protect your PLC, we suggest you add external fuses to your I/O wiring. A fast-blow fuse, with a lower current rating than the I/O bank's common current rating can be wired to each common. Or, a fuse with a rating of slightly less than the maximum current per output point can be added to each output. Refer to the I/O module specifications in Chapter 2 to find the maximum current per output point or per output common. Adding the external fuse does not guarantee the prevention of PLC damage, but it will provide added protection.



WARNING: The discrete inputs and outputs will be damaged if the signal exceeds the rated voltage.

Antenna Installation

Antenna Mounting (SE-ANT250 only)

The antenna should be bulkhead-mounted through the top of the enclosure, and will require a 15mm hole. Please follow mounting instructions found on the antenna datasheet, downloadable from <https://www.automationdirect.com/pn/SE-ANT250>.

RF Connection (SE-ANT210 or SE-ANT250)

Connect the antenna, either directly or via cable, to the RP-SMA connector at the top of the PLC as follows:

1. Ensure that both connectors are clean and dry.
2. Align and finger tighten the connectors.
3. Torque the connection to 3–5 in.-lb.



NOTE: The remote-mount antenna (SE-ANT250) is recommended for long-term use and increased performance. The direct-mount antenna (SE-ANT210) is not intended for use within a closed metal enclosure.

Planning the I/O Wiring Routes

The following guidelines provide general information on how to wire the I/O connections to CLICK PLUS PLCs. For additional information about wiring a particular I/O type refer to the corresponding information in this chapter.

1. Each terminal connection of the CLICK PLUS PLC Option Slot I/O modules can accept one 16AWG wire or two 18AWG size wires. Do not exceed this recommended capacity. Refer to Chapter 2 *Specifications* for more detailed specifications of the terminal blocks.
2. Always use a continuous length of wire. Do not splice wires to attain a needed length.
3. Use the shortest possible wire length.
4. Use wire trays for routing where possible.
5. Avoid running lower voltage wires near higher voltage wiring.
6. Avoid running input wiring close to output wiring where possible.
7. To minimize voltage drops when wires must run a long distance, consider using multiple wires for the return line.
8. Avoid running DC wiring in close proximity to AC wiring where possible.
9. Avoid creating sharp bends in the wires.
10. Install the recommended powerline filter to reduce power surges and EMI/RFI noise.

Wiring I/O Modules

There are three sizes of I/O module terminal blocks used for field wiring connections (11pt, 13pt & 20pt). They can be removed from the module for wiring convenience. There are no clips or screws retaining the terminal block. Firmly grip the block and pull it away from the PLC or I/O module. The connector terminal points have recessed screws to help minimize the risk of someone accidentally touching active wiring. Make sure the terminal blocks are properly seated against the module when replacing them and wiring is properly constrained.

For your convenience we also have DINnectors, DIN-rail mounted terminal blocks. Refer to our website or catalog for a complete listing of all available products. We strongly recommend using our *ZIPLinks* connections systems. See the following pages for *ZIPLink* compatibility and special pre-assembled cables, with the I/O connectors installed and wired.

ZIPLinks Connection Systems



ZIPLinks Cables with Connectors

ZIPLinks Modules



WARNING: For some modules, field device power may still be present on the terminal block even though the PLC system is turned off. To minimize the risk of electrical shock and equipment damage, check all field device power before you remove the connector.

ZIPLink Wiring System Compatibility Matrix for CLICK PLUS PLCs

Use the following tables to select your ZIPLink components. See our website, www.automationdirect.com, for more specifications and information on ZIPLinks.

CLICK PLUS CPU Option Module ZIPLink Selector				
PLC		ZIPLink		
CPU Option Module	Terminals	Component	Module Part No.	Cable Part No.
C2-14D1	20	Feedthrough	ZL-RTB20, ZL-RTB20-1	ZL-C0-CBL20*
C2-14D2				
C2-14DR				
C2-14AR				
C2-14TTL				
C2-08D1-4VC	20	No ZIPLinks are available for Analog Option Slot modules.		
C2-08D2-4VC				
C2-08DR-4VC				
C2-08AR-4VC				
C2-08D1-6C				
C2-08D2-6C				
C2-08DR-6C				
C2-08AR-6C				
C2-08D1-6V				
C2-08D2-6V				
C2-08DR-6V				
C2-08AR-6V				
C2-DCM				
C2-NRED	NA			
C2-OPCUA				

* Select the cable length by replacing the * with: Blank = 0.5 m, -1 = 1.0 m, or -2 = 2.0 m.

ZIPLink Wiring System Compatibility Matrix for CLICK PLCs (continued)

CLICK PLC Discrete Input Module ZIPLink Selector				
I/O Module		ZIPLink		
Input Module	Terminals	Component	Module Part No.	Cable Part No.
CO-08SIM	Not supported by ZIPLink			
CO-08ND3	11	Feedthrough	ZL-RTB20	ZL-CO-CBL11*
CO-08ND3-1				
CO-08NE3				
CO-08NA				
CO-16ND3	20	Feedthrough	ZL-RTB20	ZL-CO-CBL20*
CO-16NE3		Sensor	ZL-LTB16-24-1	
		Feedthrough	ZL-RTB20	
		Sensor	ZL-LTB16-24-1	

* Select the cable length by replacing the * with: Blank = 0.5 m, -1 = 1.0 m, or -2 = 2.0 m.

CLICK PLC Discrete Output Module ZIPLink Selector				
I/O Module		ZIPLink		
Output Module	Terminals	Component	Module Part No.	Cable Part No.
CO-08TD1	11	Feedthrough	ZL-RTB20	ZL-CO-CBL11*
CO-08TD2				
CO-08TR				
CO-08TR-3	Not supported by ZIPLink			
CO-08TA	11	Feedthrough	ZL-RTB20	ZL-CO-CBL11*
CO-16TD1	20	Feedthrough	ZL-RTB20	ZL-CO-CBL20*
CO-16TD2		Fuse	ZL-RFU20 ²	
		Relay (sinking)	ZL-RRL16-24-1	
		Feedthrough	ZL-RTB20	
		Fuse	ZL-RFU20 ²	
CO-04TRS ¹		Relay (sourcing)	ZL-RRL16-24-2	
CO-04TRS-10	Feedthrough	ZL-RTB20		
	Not supported by ZIPLink			

* Select the cable length by replacing the * with: Blank = 0.5 m, -1 = 1.0 m, or -2 = 2.0 m.

¹ NOTE: The CO-04TRS relay output is derated not to exceed 2A per point max. when used with the ZIPLink wiring system.

² NOTE: Fuses (5 x 20 mm) are not included. See Edison Electronic Fuse section for (5 x 20 mm) fuse. S500 and GMA electronic circuit protection for fast-acting maximum protection. S506 and GMC electronic circuit protection for time-delay performance. Ideal for inductive circuits.

To ensure proper operation, do not exceed the voltage and current rating of ZIPLink module. ZL-RFU20 = 2A per circuit.

ZIPLink Wiring System Compatibility Matrix for CLICK PLCs (continued)

CLICK PLC Combo I/O Module ZIPLink Selector				
I/O Module		ZIPLink		
Combo Module	# of Terms	Component	Module Part No.	Cable Part No.
C0-16CDD1	20	Feedthrough	ZL-RTB20	ZL-C0-CBL20*
C0-16CDD2				ZL-C0-CBL11*
C0-08CDR	11			ZL-C0-CBL11*

* Select the cable length by replacing the * with: Blank = 0.5m, -1 = 1.0m, or -2 = 2.0m.

CLICK PLC Analog I/O Module ZIPLink Selector				
I/O Module		ZIPLink		
Analog Module	# of Terms	Component	Module Part No.	Cable Part No.
C0-04POT		Not supported by ZIPLink		
C0-04AD-1	11	Feedthrough	ZL-RTB20	ZL-C0-CBL11*
C0-04AD-2	11			ZL-C0-CBL11*
C0-04RTD	20	No ZIPLinks are available for RTD and thermocouple modules.		
C0-04THM	11			
C0-04DA-1	11	Feedthrough	ZL-RTB20	ZL-C0-CBL11*
C0-04DA-2	11			ZL-C0-CBL11*
C0-4AD2DA-1	20			ZL-C0-CBL20*
C0-4AD2DA-2	20			ZL-C0-CBL20*

* Select the cable length by replacing the * with: Blank = 0.5m, -1 = 1.0m, or -2 = 2.0m.

I/O Wiring Checklist

Use the following guidelines when wiring the I/O modules in your system.

1. There is a limit to the size of wire the modules can accept. The table below lists the suggested AWG. When making terminal connections, follow the suggested torque values.

Terminal Block AWG and Torque	
Connector Type (all)	Removable Terminal Block
Wire Range	28-16 AWG
Wire strip length	7.0 mm
Screw Size	M2.0
Screw Torque	Analog, analog combo I/O modules only: 1.7 lb-in; All other modules: 2.0 to 2.2 lb-in



NOTE: Recommended wire is 16 AWG Type TFFN or Type MTW. Other types of 16 AWG may be acceptable, depending on the thickness and stiffness of the wire insulation. If the insulation is too thick or stiff, and a majority of the module's I/O points are used, then the plastic terminal cover may not close properly or the connector may pull away from the module. This applies especially for high temperature thermoplastic insulation material such as THHN.

2. Always use a continuous length of wire, do not combine wires to attain a needed length.
3. Use the shortest possible wire length.
4. Use wire trays for routing where possible.
5. Avoid running wires near high energy wiring. Also, avoid running input wiring close to output wiring where possible.
6. To minimize voltage drops when wires must run a long distance, consider using multiple wires for the return line.
7. Avoid running DC wiring in close proximity to AC wiring where possible.
8. Avoid creating sharp bends in the wires.
9. To reduce the risk of having a module damaged, we suggest you add external fuses to your I/O wiring. A fast blow fuse, with a lower current rating than the I/O module fuse, can be added to each common, or a fuse with a rating of slightly less than the maximum current per output point can be added to each output. Refer to our catalog for a complete line of DINnectors, DIN-rail mounted fuse blocks.
10. If using relay outputs with inductive loads, consider using surge suppressors (see section on surge suppression later in this chapter).

System Wiring Strategies

The CLICK PLUS PLC system is very flexible and will work in many different wiring configurations. By studying this section before actual installation, you can find the best wiring strategy for your application. This will help to lower system cost and wiring errors, and avoid safety problems.

PLC Isolation Boundaries

PLC circuitry is divided into three main regions separated by isolation boundaries, shown in the drawing below. Electrical isolation provides safety, so that a fault in one area does not damage an adjacent area. A powerline filter will provide isolation between the power source and the power supply. The transformer in the power supply provides magnetic isolation between the primary and secondary sides. Optical isolators provide optical isolation in Input and Output circuits. These methods isolate logic circuitry from the field side, where factory machinery connects. The discrete inputs are isolated from the discrete outputs, because each is isolated from the logic side. Isolation boundaries protect devices such as PC and HMI that are connected to the communication ports, from power input faults or field wiring faults. When wiring a PLC, it is extremely important to avoid making external connections that connect logic side circuits to more than one circuit.

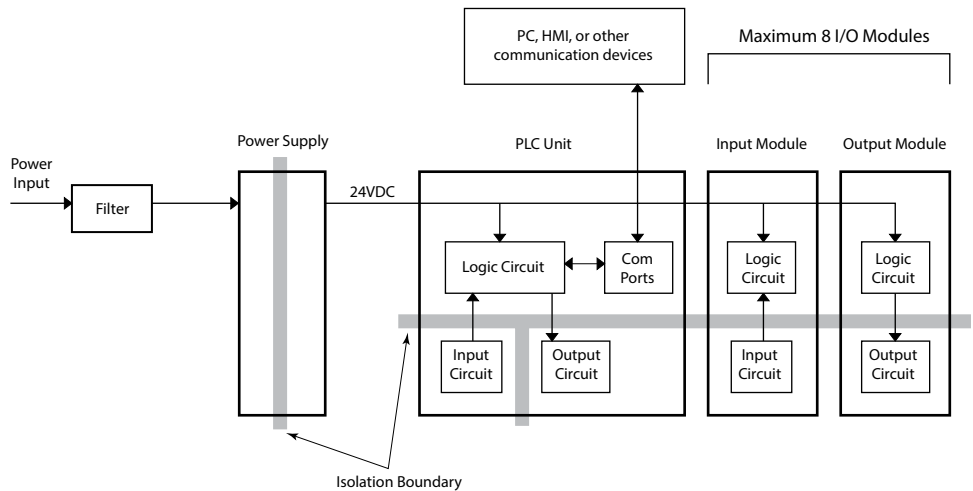

NOTE: If you do not use one of the CLICK PLC power supplies C0-00AC and C0-01AC to provide 24VDC to the PLC module (and I/O modules), be sure the power supply you use has isolation with a transformer.

Powering I/O Circuits

In most applications, it will be necessary to power the input devices from one power source, and to power output loads from another source. Loads often require high-energy AC power, while input sensors use low-energy DC. If a machine operator is likely to come in close proximity to input wiring, then for safety reasons, high-energy output circuits would be isolated.

For the DC input/output circuits, you can use the same power source as the PLC module (and I/O modules). However, you lose the isolation between the logic circuits and the input/output circuits. For AC input/output circuits, you don't need to worry about sharing the 24VDC.

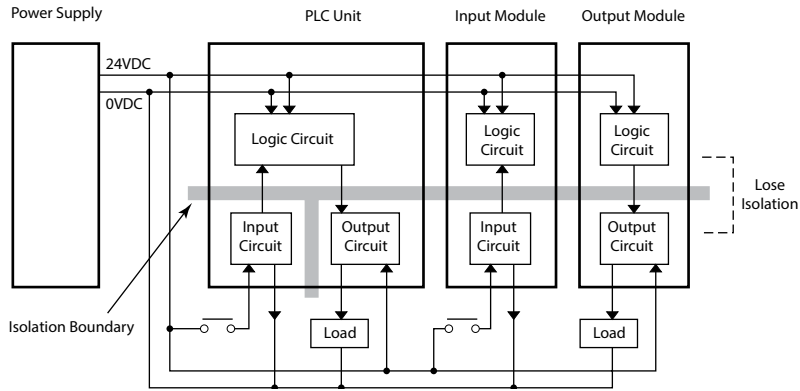

To keep the isolation between the logic circuits and the input/output circuits, we recommend using another power supply for the DC input and output circuits.

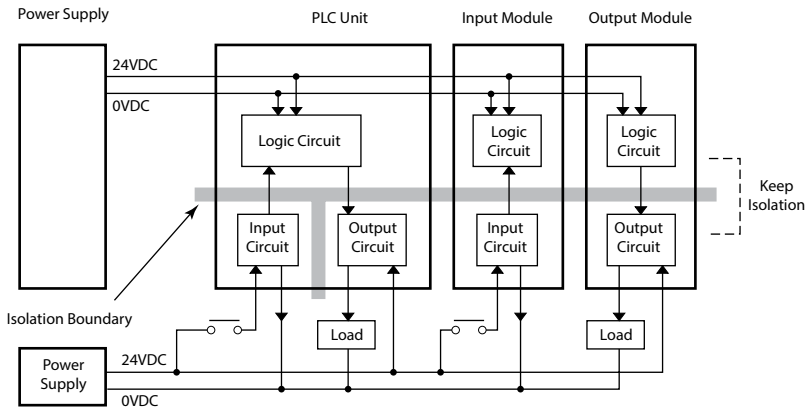

Sinking/Sourcing Concepts

Before wiring field devices to the PLC I/O, it's necessary to have a basic understanding of sinking and sourcing concepts. Use of these terms occurs frequently in input or output circuit discussions. The purpose of this section is to explain the terms. The short definitions are as follows:

- Sinking = Path to supply ground (-) or switching ground
- Sourcing = Path to supply source (+) or switching +V

These terms only apply to DC circuits, not AC circuits. Input and output points that are either sinking or sourcing can conduct current in only one direction. This means it is possible to wire the external supply and field device to the I/O point with current trying to flow in the wrong direction, in which case the circuit will not operate.

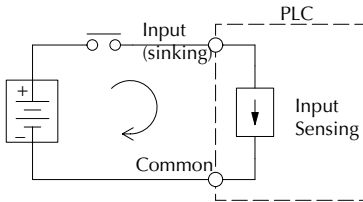

The diagram on the left shows a sinking PLC input. To properly connect the external supply, connect it so the input provides a path to ground (-). Start at the PLC input terminal, follow through the input sensing circuit, exit at the common terminal, and connect the supply (-) to the common terminal.

The switch between the supply (+) and the input completes the circuit. Current flows in the direction of the arrow when the switch is closed. By applying the circuit principle above to the four possible combinations of input/output sinking/sourcing types, we have the four circuits as shown below.

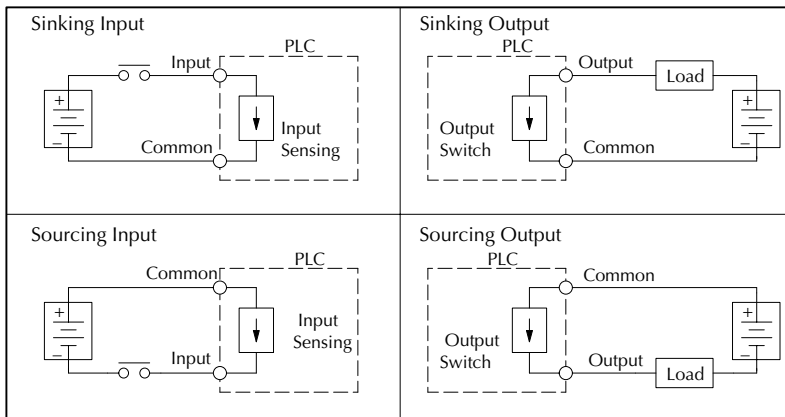

I/O “Common Terminal” Concepts

In order for a PLC I/O circuit to operate, current must enter at one terminal and exit at another. This means at least two terminals are associated with every I/O point. In the figure to the right, the input or output terminal is the main path for the current. One additional terminal must provide the return path to the power supply.

If there was unlimited module space, then every I/O point could have two dedicated terminals as the previous figure shows. Providing this level of flexibility is not practical or necessary for most applications. So, most I/O point groups share the return path (common) among two or more I/O points. The figure to the right shows a group (or bank) of 4 input points which share a common return path. In this way, the four inputs require only five terminals instead of eight.

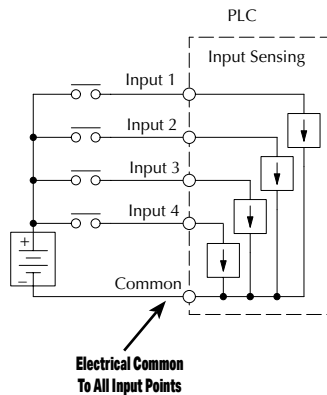
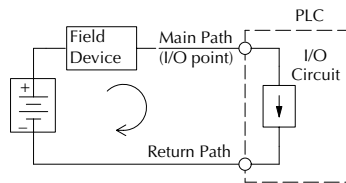

NOTE: In the circuit above, the current in the common path is equal to the sum of the energized channels. This is especially important in output circuits, where larger gauge wire is sometimes needed for the commons.

DC Input Wiring Methods

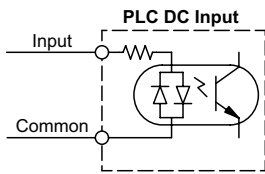

CLICK PLCs and I/O modules with DC inputs can be wired as either sinking or sourcing inputs. The dual diodes (shown in this diagram) allow current to flow in either direction. Inputs grouped by a common point must be either all sinking or all sourcing. DC inputs typically operate in the range of +12-24 VDC.

Sinking Input Sensor (NPN Type) to PLC Sourcing Input

In the following example, a field device has an open-collector NPN transistor output. When energized, it sinks current to ground from the DC input point. The PLC input current is sourced from the common terminal connected to power supply (+).

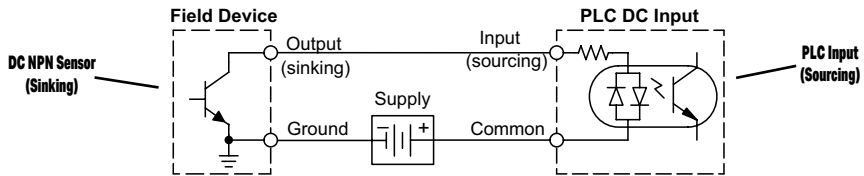

Sourcing Input Sensor (PNP Type) to PLC Sinking Input

In the following example, a field device has an open-emitter PNP transistor output. When energized, it sources current to the PLC input point, which sinks the current to ground. Since the field device loop is sourcing current, no additional power supply is required for the module.

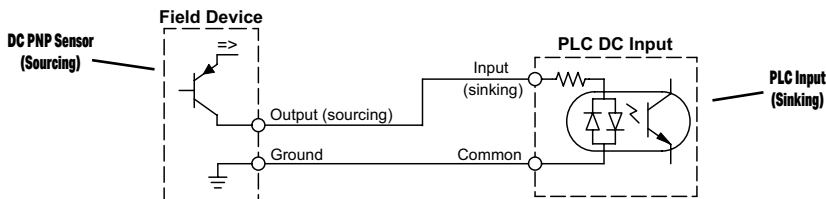

DC Output Wiring Methods

CLICK PLCs and I/O modules with DC output circuits are wired as all current sinking only or current sourcing only depending on which PLC or output module part number is used. DC outputs typically operate in the range of +5-24 VDC.

PLC Sinking Output to Sourcing Load Device

Many applications require connecting a PLC output point to a DC input on a field device load. This type of connection is made to carry a low-level DC signals.

In the following example, the PLC output point sinks current to ground (common) when energized. The output is connected to a field device load with a sourcing input.

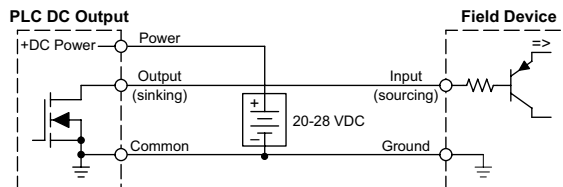

PLC DC Sinking Output to Sinking Load Device

In the example below, a PLC sinking output point is connected to the sinking input of a field device load. In this case, both the PLC output and field device input are sinking type. Since the circuit must have one sourcing and one sinking device, we add sourcing capability to the PLC output by using a pull-up resistor. In the circuit below, we connect R_{pull-up} from the output to the DC output circuit power input.

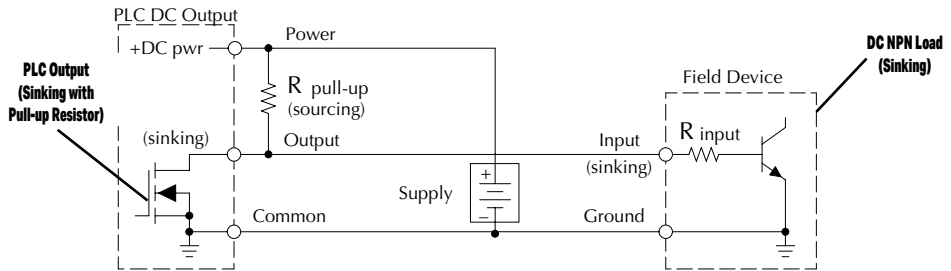

NOTE 1: DO NOT attempt to drive a heavy load (>25 mA) with this pull-up method.

NOTE 2: Using the pull-up resistor to implement a sourcing output has the effect of inverting the output point logic. In other words, the field device input is energized when the PLC output is OFF, from a ladder logic point-of-view. Your ladder program must comprehend this and generate an inverted output. Or, you may choose to cancel the effect of the inversion elsewhere, such as in the field device.

It is important to choose the correct value of R_{pull-up}. In order to do so, we need to know the nominal input current to the field device (I_{input}) when the input is energized. If this value is not known, it can be calculated as shown (a typical value is 15 mA). Then use I_{input} and the voltage of the external supply to compute R_{pull-up}. Then calculate the power P_{pull-up} (in watts), in order to size R_{pull-up} properly.

$$I_{\text{input}} = \frac{V_{\text{input (turn-on)}}}{R_{\text{input}}}$$

$$R_{\text{pull-up}} = \frac{V_{\text{supply}} - 0.7}{I_{\text{input}}} - R_{\text{input}}$$

$$P_{\text{pull-up}} = \frac{V_{\text{supply}}^2}{R_{\text{pull-up}}}$$

Relay Outputs - Wiring Methods

Relay outputs are available for the CLICK PLCs. Relays are best for the following applications:

- Loads that require higher currents than the solid-state outputs can deliver
- Cost-sensitive applications
- Some output channels need isolation from other outputs (such as when some loads require different voltages than other loads)

Some applications in which NOT to use relays:

- Loads that require currents under 10mA
- Loads which must be switched at high speed or heavy duty cycle

Relay with Form A contacts

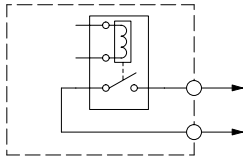

Relay outputs in the CLICK PLCs and modules are available in two contact arrangements. Form A type, or SPST (single pole, single throw) type. They are normally open and are the simplest to use. The Form C, or SPDT (single pole, double throw) type has a center contact which moves and a stationary contact on either side. This provides a normally closed contact and a normally open contact.

Relay with Form C contacts

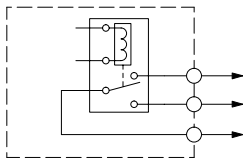

Some relay output module's relays share common terminals, which connect to the wiper contact in each relay of the bank. Other relay modules have relays which are completely isolated from each other. In all cases, the module drives the relay coil when the corresponding output point is on.

Relay Outputs – Transient Suppression for Inductive Loads in a Control System

The following pages are intended to give a quick overview of the negative effects of transient voltages on a control system and provide some simple advice on how to effectively minimize them. The need for transient suppression is often not apparent to the newcomers in the automation world. Many mysterious errors that can afflict an installation can be traced back to a lack of transient suppression.

What is a Transient Voltage and Why is it Bad?

Inductive loads (devices with a coil) generate transient voltages as they transition from being energized to being de-energized. If not suppressed, the transient can be many times greater than the voltage applied to the coil. These transient voltages can damage PLC outputs or other electronic devices connected to the circuit, and cause unreliable operation of other electronics in the general area. Transients must be managed with suppressors for long component life and reliable operation of the control system.

This example shows a simple circuit with a small 24V/125mA/3W relay. As you can see, when the switch is opened, thereby de-energizing the coil, the transient voltage generated across the switch contacts peaks at 140V.

Example: Circuit with no Suppression

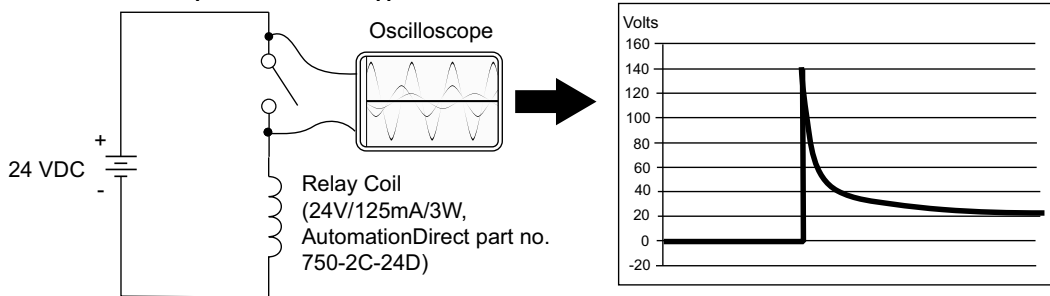

In the same circuit, replacing the relay with a larger 24V, 290mA, 7W relay will generate a transient voltage exceeding 800V (not shown). Transient voltages like this can cause many problems, including:

- Relay contacts driving the coil may experience arcing, which can pit the contacts and reduce the relay's lifespan.
- Solid state (transistor) outputs driving the coil can be damaged if the transient voltage exceeds the transistor rating. In extreme cases, complete failure of the output can occur the very first time a coil is de-energized.
- Input circuits, which might be connected to monitor the coil or the output driver, can also be damaged by the transient voltage.

A very destructive side-effect of the arcing across relay contacts is the electromagnetic interference (EMI) it can cause. This occurs because the arcing causes a current surge, which releases RF energy. The entire length of wire between the relay contacts, the coil, and the power source carries the current surge and becomes an antenna that radiates the RF energy. It will readily couple into parallel wiring and may disrupt the PLC and other electronics in the area. This EMI can make an otherwise stable control system behave unpredictably at times.

PLC's Integrated Transient Suppressors

Although the PLC's outputs typically have integrated suppressors to protect against transients, they are not capable of handling them all. It is usually necessary to have some additional transient suppression for an inductive load.

Here is another example using the same 24V, 125mA, 3W relay used earlier. This example measures the PNP transistor output of a D0-06DD2 PLC, which incorporates an integrated Zener diode for transient suppression. Instead of the 140V peak in the first example, the transient voltage here is limited to about 40V by the Zener diode. While the PLC will probably tolerate repeated transients in this range for some time, the 40V is still beyond the module's peak output voltage rating of 30V.

Example: Small Inductive Load with Only Integrated Suppression

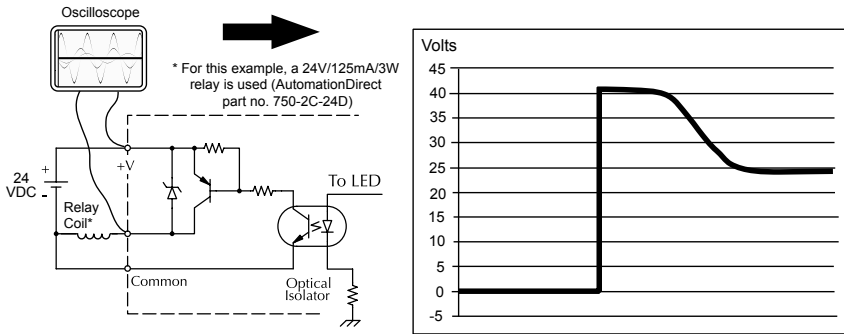

The next example uses the same circuit as above, but with a larger 24V, 290mA, 7W relay thereby creating a larger inductive load. As you can see, the transient voltage generated is much worse, peaking at over 50V. Driving an inductive load of this size without additional transient suppression is very likely to permanently damage the PLC output.

Example: Larger Inductive Load with Only Integrated Suppression

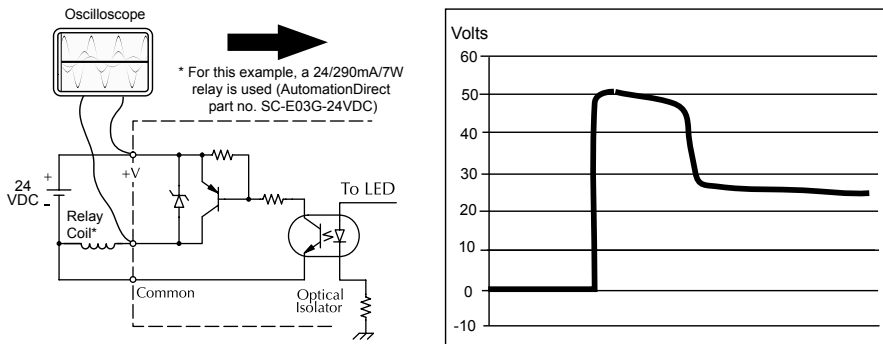

Additional transient suppression should be used in both these examples. If you are unable to measure the transients generated by the connected loads of your control system, using additional transient suppression on all inductive loads would be the safest practice.

Types of Additional Transient Protection

DC Coils:

The most effective protection against transients from a DC coil is a flyback diode. A flyback diode can reduce the transient to roughly 1V over the supply voltage, as shown in this example.

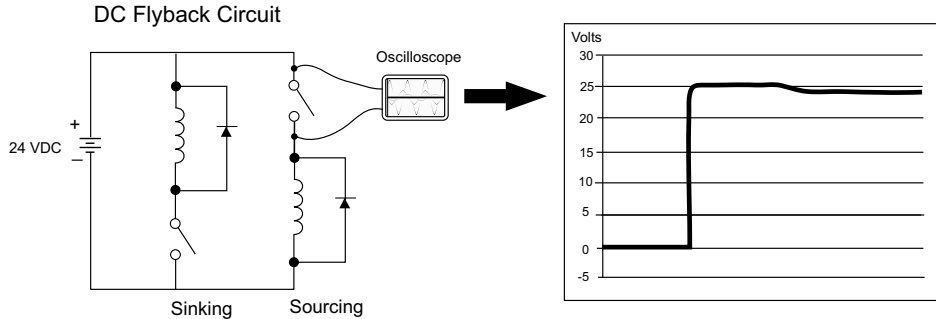

Many AutomationDirect socketed relays and motor starters have add-on flyback diodes that plug or screw into the base, such as the AD-ASMD-250 protection diode module and 784-4C-SKT-1 socket module shown below. If an add-on flyback diode is not available for your inductive load, an easy way to add one is to use an AutomationDirect DN-D10DR-A diode terminal block, a 600VDC power diode mounted in a slim DIN rail housing.



AD-ASMD-250
Protection Diode Module



784-4C-SKT-1
Relay Socket

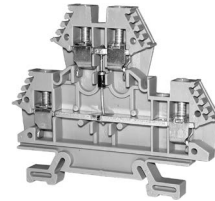

DN-D10DR-A
Diode Terminal Block

Two more common options for DC coils are Metal Oxide Varistors (MOV) or TVS diodes. These devices should be connected across the driver (PLC output) for best protection as shown below. The optimum voltage rating for the suppressor is the lowest rated voltage available that will NOT conduct at the supply voltage, while allowing a safe margin.

AutomationDirect's ZL-TSD8-24 transorb module is a good choice for 24VDC circuits. It is a bank of 8 uni-directional 30V TVS diodes. Since they are uni-directional, be sure to observe the polarity during installation. MOVs or bi-directional TVS diodes would install at the same location, but have no polarity concerns.



ZL-TSD8-24
Transorb Module

DC MOV or TVS Diode Circuit

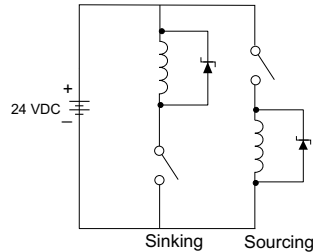

AC Coils:

Two options for AC coils are MOVs or bi-directional TVS diodes. These devices are most effective at protecting the driver from a transient voltage when connected across the driver (PLC output) but are also commonly connected across the coil. The optimum voltage rating for the suppressor is the lowest rated voltage available that will NOT conduct at the supply voltage, while allowing a safe margin.

AutomationDirect's ZL-TSD8-120 transorb module is a good choice for 120VAC circuits. It is a bank of eight bi-directional 180V TVS diodes.



ZL-TSD8-120
Transorb Module

AC MOV or Bi-Directional Diode Circuit

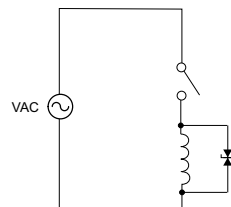

NOTE: Manufacturers of devices with coils frequently offer MOV or TVS diode suppressors as an add-on option which mount conveniently across the coil. Before using them, carefully check the suppressor ratings. Just because the suppressor is made specifically for that part does not mean it will reduce the transient voltages to an acceptable level.

For example, a MOV or TVS diode rated for use on 24-48 VDC coils would need to have a high enough voltage rating to NOT conduct at 48V. That suppressor might typically start conducting at roughly 60VDC. If it were mounted across a 24V coil, transients of roughly 84V (if sinking output) or -60V (if sourcing output) could reach the PLC output. Many semiconductor PLC outputs cannot tolerate such levels.

LAN Provisioning over Bluetooth

Provisioning your Wireless CLICK PLUS PLC via Bluetooth (Models C2-02CPU and C2-03CPU only)

A new CLICK PLUS C2-02CPU, C2-02CPU-2, C2-03CPU or C2-03CPU-2 has Bluetooth disabled by default. You must first enable the Bluetooth port in the project to use the CLICK PLUS Provisioning App. If you are setting up a Wi-Fi connection, you must also enable Wi-Fi in the project. The Provisioning App allows you to change the needed Wi-Fi and network settings of an already created project. Once the Wi-Fi is configured to connect to the local network access point, you can then connect the Click Programming software via Wi-Fi to load and edit the project. The temporary settings used for provisioning are stored in temporary memory and will be overwritten by the project settings when you write a project to the PLC.

Install an external antenna

In order to connect to the CLICK PLUS PLC over Bluetooth or WLAN, you will need to install an external 2.4 GHz antenna. We recommend the remote-mounted AutomationDirect P/N SE-ANT250 for a permanent installation. The direct-mounted AutomationDirect P/N SE-ANT210 will also work, but is not intended for use inside a closed metal enclosure.

Prepare a Mobile Device for Connection

If you haven't already done so, install the CLICK PLUS Provisioning mobile app from the Apple App Store or Google Play Store (CLICK PLUS Provisioning, published by Automationdirect.com).



Provisioning your Wireless CLICK PLUS PLC via Bluetooth, (cont'd)

Find the New CPU

Connect to the CPU, as follows:

1. Connect to the CPU through USB or Ethernet, set up the project password and enable the Bluetooth and/or WLAN Port(s). Send to CPU.
2. Open the CLICK PLUS Provisioning App.
3. Tap *Start* in the App.
4. Press the pairing button on the CLICK PLUS CPU for 1 second. The BT (Bluetooth) LED will start flashing.
5. The App will find the CLICK PLUS PLC that is in Provisioning mode. The blue BT LED will be ON solid when the App is connected to the PLC. If the App detects that the PLC is factory new and the network settings have not been configured, it will prompt you to Tap *Next* to begin the provisioning process.



NOTE: If you find that you need to change the settings in order to connect to the network. The PLC can be placed in pairing mode and the provisions app can be used to make needed changes.

Provisioning your Wireless CLICK PLUS PLC via Bluetooth, (cont'd)

Name the CPU and select port to configure

6. You will be requested to assign a name to the PLC. This name will be used to identify it on the network when using the programming software connection Ethernet browse tool. It is good practice to choose a unique name if there are other CLICK PLCs on the network. Enter a name for the PLC and tap *Next*.
7. Choose which network port to provision. This will configure the CLICK PLUS network address settings for the purpose of connecting the programming software.

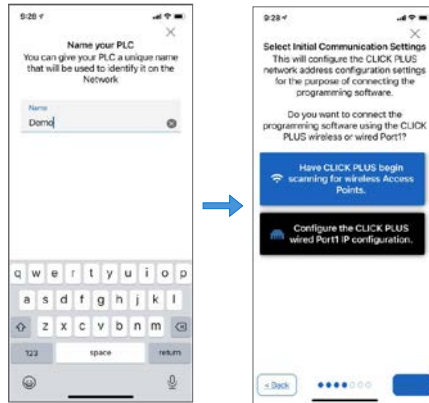

Setup the Wireless LAN Connection (Skip for Wired Connection)

For this option you will need an active Network Access point available within range of the CLICK PLUS PLC, and know the password to allow the PLC to connect to the Network.

8. The CLICK PLC will scan for any access point within range and then display all access points that are available (you may need to scroll the list to find the desired Access Point). Select an Access Point and type in the correct password that the PLC will need to connect. If the incorrect password is entered, you will be prompted to correct it after the CLICK PLUS fails to connect.

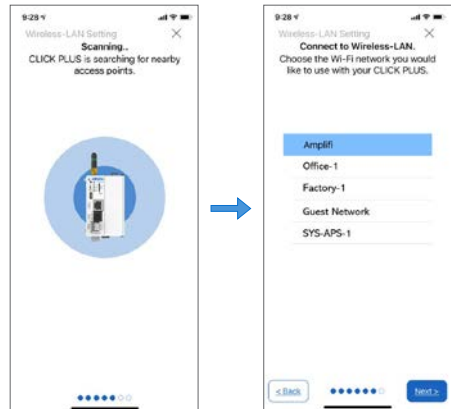

Provisioning your Wireless CLICK PLUS PLC via Bluetooth, (cont'd)

Setup the Network Parameters

9. Once the PLC is connected to the wireless access point or wired network, choose which IP address configuration to use.
 - i. Use DHCP: Automatically assign a network IP address to the CLICK PLUS PLC. This is often the simplest way to connect. Tap *Next* to continue.
 - ii. Use Default Fixed Address: The CLICK PLUS wireless LAN default IP address is 192.168.0.11. This can be selected if it is a valid IP address for your wireless network. Tap *Next* to continue.
 - iii. Use the following IP address: Choose this option if you need to input a valid IP address for your network. Tap *Next* to continue

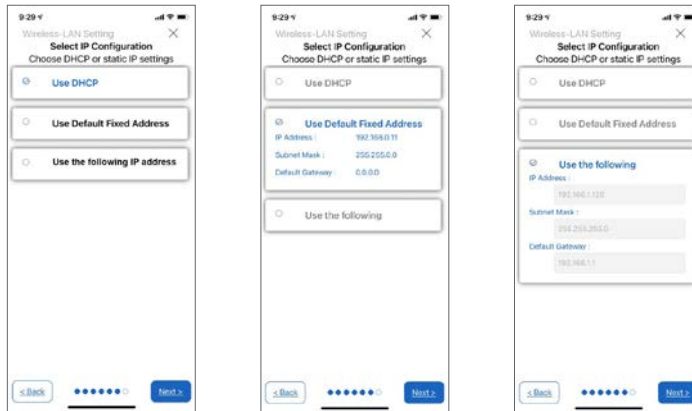

10. The CLICK PLUS will connect to the access point and exchange configuration information. If the settings are correct, the App will show the Completion screen and the network settings of the CLICK PLUS can be viewed. If using a wireless connection, the CLICK PLUS WLAN LED will also be ON. The PLC is now connected to the network and accessible to PC's running the CLICK Programming Software and connected to the same network.

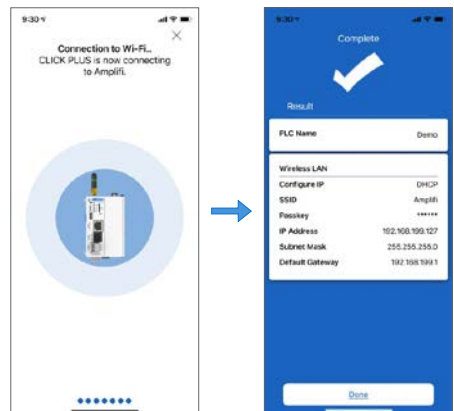

Option Slot Analog I/O Configuration

The following Option Slot Analog I/O modules are available. (Stackable Analog I/O modules are shown on following page.)

Option Slot Analog Units	Inputs	Outputs
C2-08D1-4VC	2 - Current/ Voltage, Selectable	2 - Current/ Voltage, Selectable
C2-08D2-4VC		
C2-08DR-4VC		
C2-08AR-4VC		
C2-08D1-6C	4 - Current only	2 - Current only
C2-08D2-6C		
C2-08DR-6C		
C2-08AR-6C		
C2-08D1-6V	4 - Voltage only	2 - Voltage only
C2-08D2-6V		
C2-08DR-6V		
C2-08AR-6V		

Terminal Block Wiring - Analog Option Slot Units

The C2-08xx-4VC Analog Option Slot modules have two analog inputs and two analog outputs. You can select analog voltage or analog current for each analog I/O separately. As shown below, you must use the proper terminal when using analog voltage or analog current.

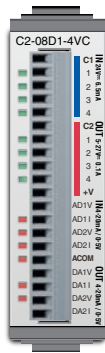

C2-08xx-4VC Analog Terminals	
Terminal Name	Terminal Description
AD1V	Analog voltage input
AD1I	Analog current input
AD2V	Analog voltage input
AD2I	Analog current input
ACOM	Common for all analog inputs and outputs
DA1V	Analog voltage output
DA1I	Analog current output
DA2V	Analog voltage output
DA2I	Analog current output

The C2-08xx-6C Analog Option Slot modules have four analog current inputs and two analog current outputs.

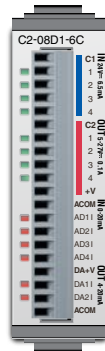

C2-08xx-6C Analog Terminals	
Terminal Name	Terminal Description
ACOM	Common for analog inputs
AD1- AD4I	Analog current input
DA+V	Analog voltage source
DA1- DA2I	Analog current output
ACOM	Common for analog outputs

The C2-08xx-6V Analog Option Slot modules have four analog voltage inputs and two analog voltage outputs.

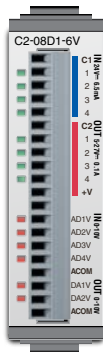

C2-08xx-6V Analog Terminals	
Terminal Name	Terminal Description
AD1V- AD4V	Analog voltage input
ACOM	Common for analog inputs
DA1V- DA2V	Analog voltage output
ACOM	Common for analog outputs

Terminal Block Wiring - Stackable Analog I/O Modules

The terminal block wiring will vary depending on which analog I/O module is being used. For example, the C0-04AD-1 module shown here has four analog terminals, CH1 through CH4, which are all current inputs.

See Chapter 2. Specifications for terminal block wiring diagrams and specifications for all the analog I/O modules.

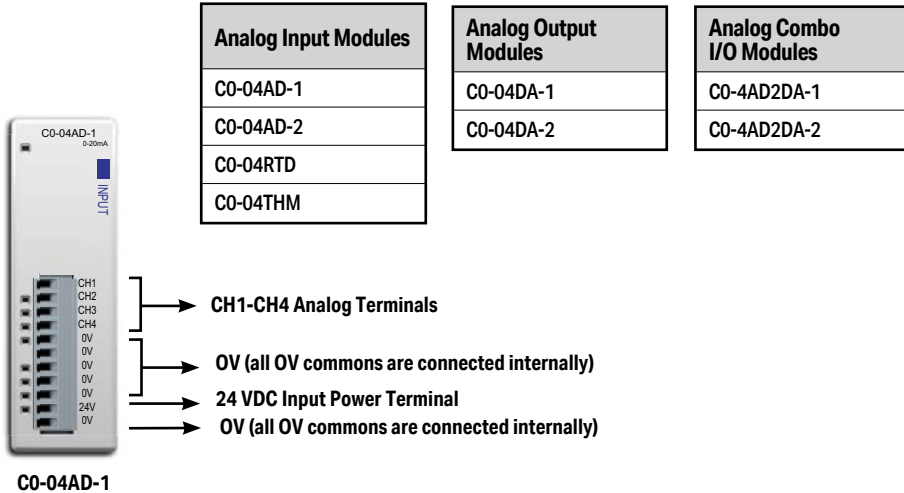

Configuration in the CLICK Programming Software

All analog I/O points can be configured in the CLICK Programming Software. There is no jumper switch in these modules.

CLICK PLUS Option Slot Analog Modules

The Option Slot analog modules cannot detect which terminal is used between the analog voltage and analog current, so you must configure which analog type is used for each analog I/O in the CLICK programming software.

Connect the CLICK programming software to the CLICK PLUS PLC unit, then open the System Configuration window as shown below.

(Pull-down menu: Setup > System Configuration)

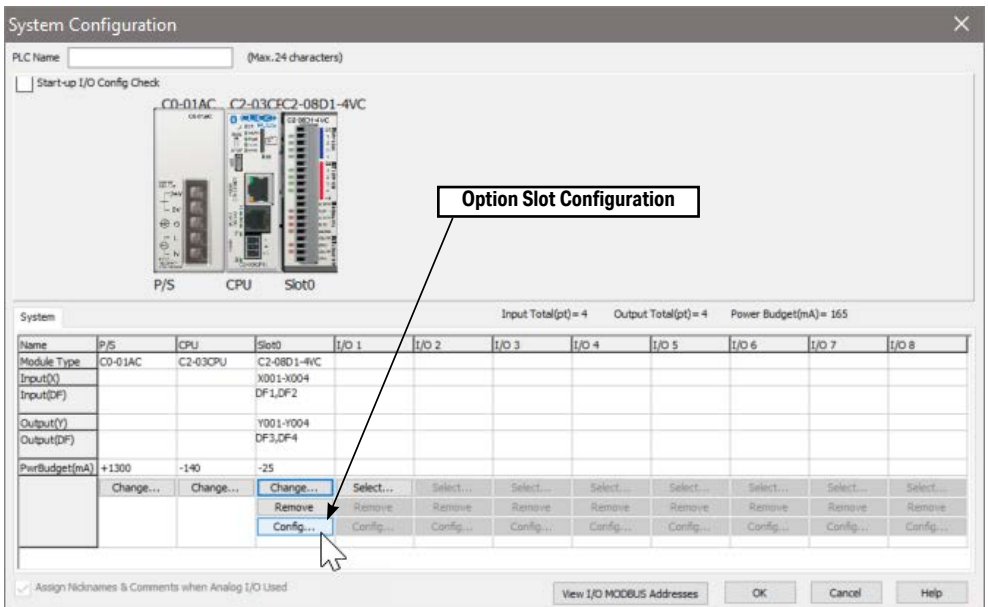

Click the Input tab to configure the analog inputs and/or click the Output tab to configure the analog outputs. The Input tab is shown below, but the Output tab looks very similar.

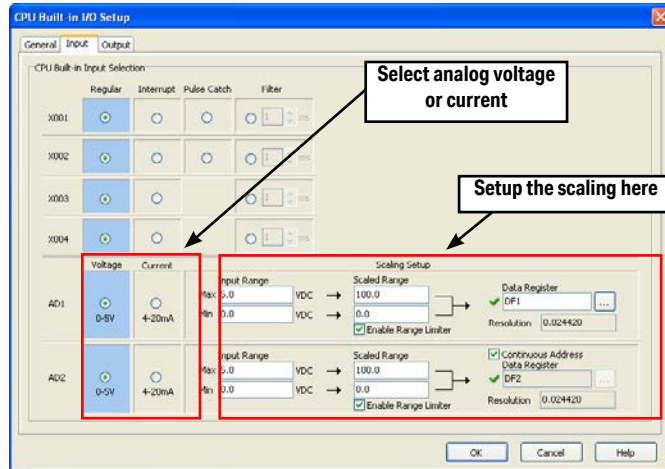

You can select the analog voltage or analog current with the radio buttons. Also use this screen to set the scaling for each Analog I/O. Click the Help button on the right bottom to learn about the scaling feature.

After you configure the Analog I/O, download the project into the Analog PLC module.

Analog I/O Modules

To configure an Analog I/O module, connect the CLICK programming software to the CLICK PLC including the Analog I/O module, then open the System Configuration window as shown below (Pull-down menu: Setup > System Configuration).

Click the 'Config...' button to open the configuration window to configure each analog I/O module.

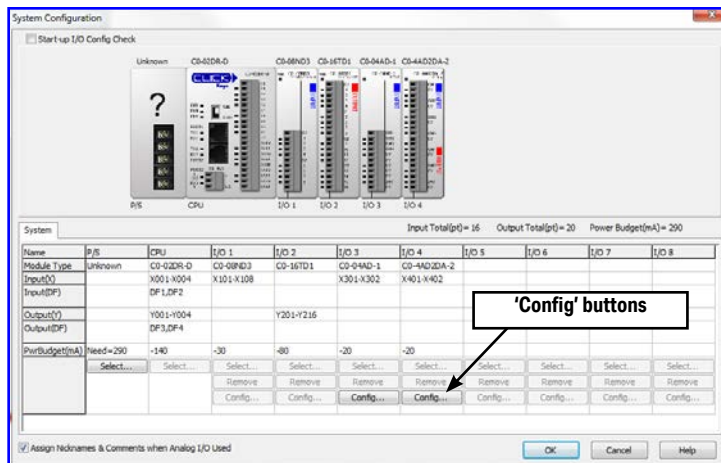

The following is the configuration window for the C0-04AD-1 current input I/O module.

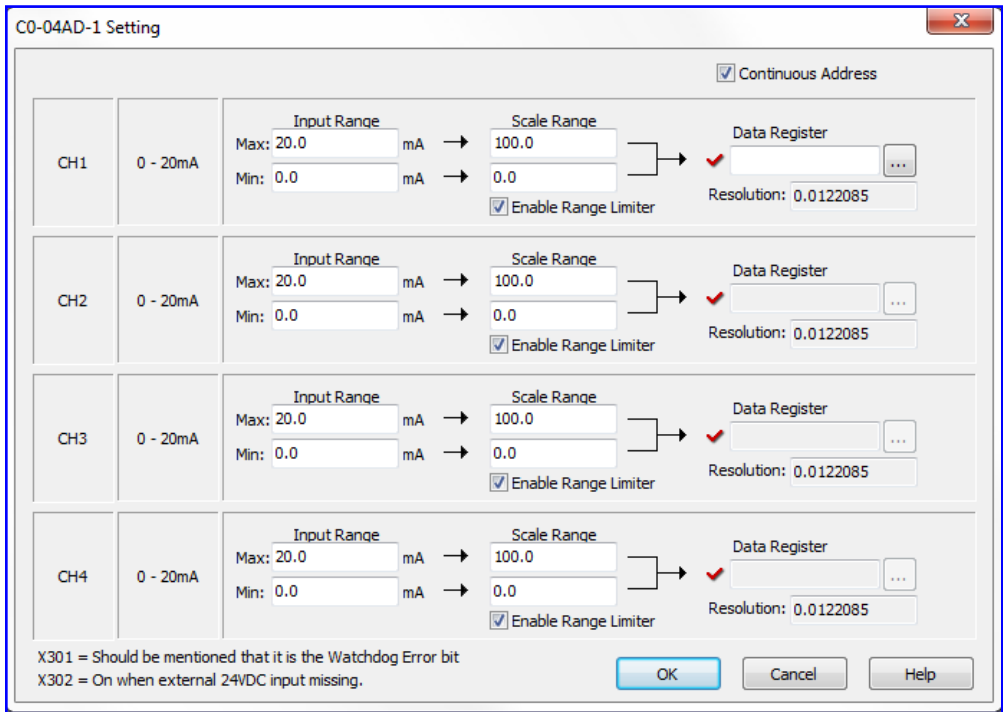

In the CLICK PLC, all analog data is stored in the DF memory addresses. Assign DF memory addresses to the Data Register fields. You can also set up the scaling in this configuration window. For more detailed explanation about this configuration window, refer to the help topic by clicking the Help button on the bottom right corner.

After configuring all the analog I/O modules, download the CLICK project into the CLICK PLC.

Analog I/O Monitoring

To monitor the current analog I/O values, you can use the System Monitor window as shown below (Pull-down menu: Monitor > System Monitor).

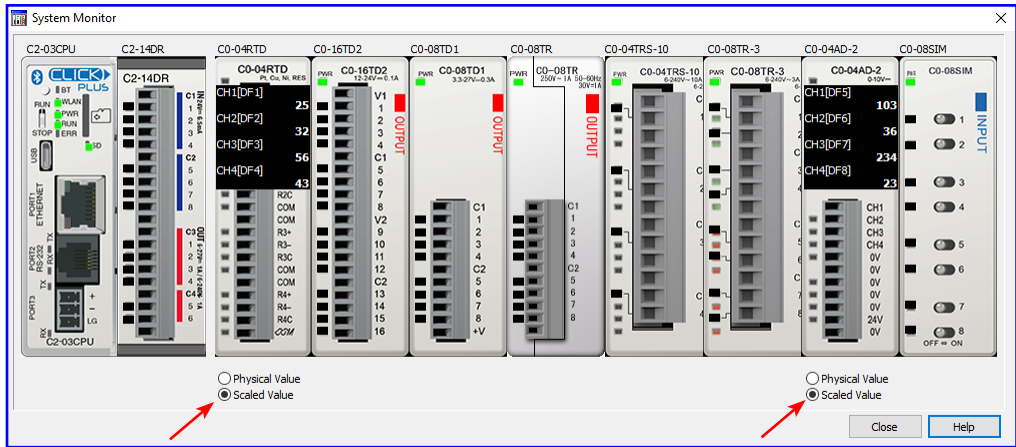

You can switch the displayed values between the Physical Value and Scaled Value with the radio buttons below the respective graphic.

High-Speed Input/Output Configuration

CLICK PLUS Option Slot modules that have digital inputs and outputs with High-Speed capability are shown below. The maximum number of available Single Input Counters will depend on the combination of features used.

Module Part Number	High-Speed Input Points	High-Speed Counters (Max.)	High-Speed Output Points	High-Speed Outputs (Max.)
C2-14D1	8	6	3	3
C2-14D2				
C2-14TTL				
C2-14DR			N/A	N/A
C2-14AR	N/A	N/A		
C2-08D1-4VC	4	4	2	2
C2-08D2-4VC				
C2-08DR-4VC			N/A	N/A
C2-08AR-4VC	N/A	N/A		
C2-08D1-6C	4	4	2	2
C2-08D2-6C				
C2-08DR-6C			N/A	N/A
C2-08AR-6C	N/A	N/A		
C2-08D1-6V	4	4	2	2
C2-08D2-6V				
C2-08DR-6V			N/A	N/A
C2-08AR-6V	N/A	N/A		



NOTE: The Option Slot Module must be installed in Option Slot 0 to use High-Speed Input/Output functions.

Chapter 3: Installation and Wiring

Each Input Mode consumes the available number of High-Speed Inputs. The Reset and Enable features can use High-Speed Inputs, Digital Input Modules, or Control Relays (Internal Bits). The transition delay (latency) is longer for Input Modules and Control Relays since these are scan based.

High-Speed Mode	Input Type	High-Speed Inputs Required	Reset Input	Enable Input
High-Speed Count (HSC)	Up Count	1	Optional	Optional
	Down Count			
	Up and Down Counts	2		
	Pulse and Direction			
	Quadrature (A and B)			
	Quadrature (A and B with Z)	3	N/A	
Interval Measurement (ITV)	Single Input	1	Optional	
	Dual Inputs	2		
Duration Measurement (DUR)	Single Input	1		
Frequency Measurement (FRQ)	Single Input	1	N/A	N/A
	Quadrature (A and B)	2		

High-Speed Mode	Output Type	High-Speed Outputs Required	Limit Switches
Pulse Train Output (PTO)	Pulse	1	Optional
	Direction	Optional	
Pulse Width Modulation (PWM)	Pulse	1	N/A

Due to internal resource limitations, there is a limit to the number of settings that can be made when using the high-speed counter function and the PTO function simultaneously. The CLICK software High Speed Configuration will automatically limit the selections based on already configured points and the specific Slot I/O Module.

Wiring Examples: High-Speed Inputs

Quadrature with Reset (Z-Pulse):

Sinking Encoder (Open Collector)

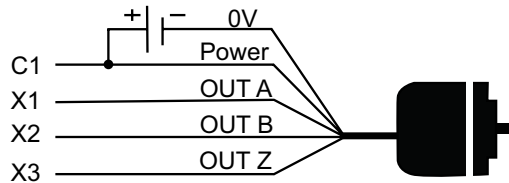

Sourcing Encoder

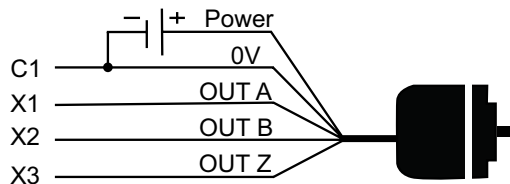

3-Wire Sensors

NPN Sensor (Sinking)

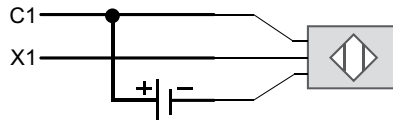

PNP Sensor (Sourcing)

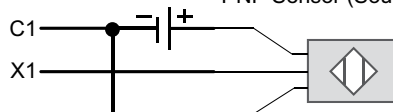

Wiring Examples: High-Speed Outputs

Stepper Motor Drive

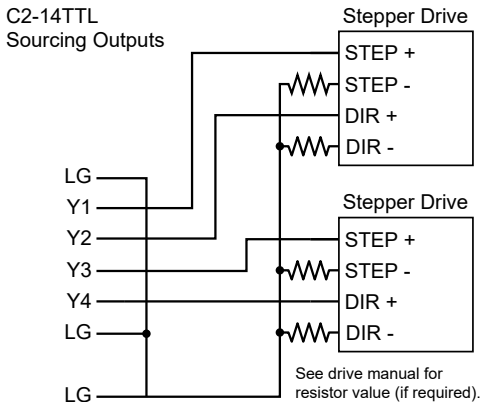
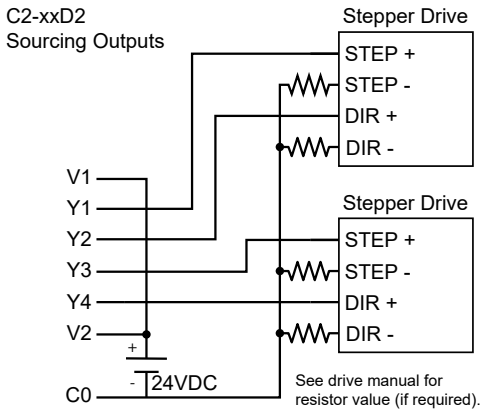
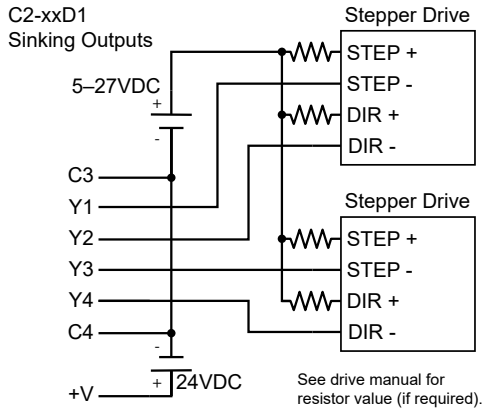

Wiring Examples: High-Speed Outputs

Servo Motor Drive

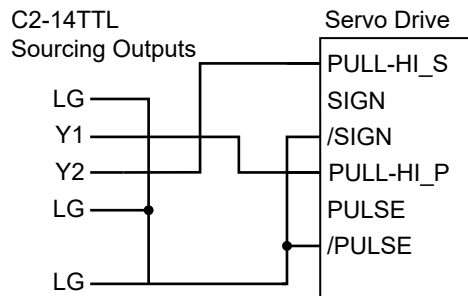
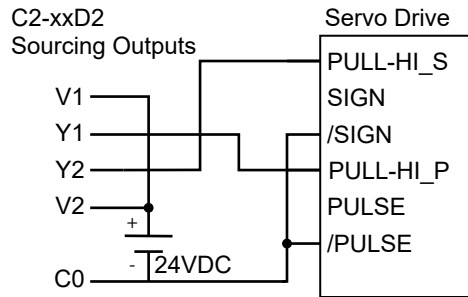
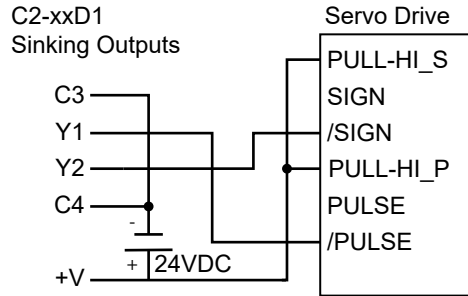

Setting Up and Using an SD Card

Writing to SD Card Devices

Up to 16 addresses of any type may be configured in the CLICK programming software to log data. Along with the 16 address limit, available storage is subject to the memory capacity of the SD card. A new log file can be created based on a time period or an event trigger.

Memory Devices should be formatted according to the following guidelines to insure best performance and integrity of logged data.

SD Card Type	Capacity	Supported Formatting
SD	Not Supported	
SDHC	4GB to 32GB	FAT32
SDXC	Not Supported	

SD cards must be formatted using the SD formatter provided by the SD Association at www.sdcard.org using the standard allocation unit size for best performance.

Minimizing Data Errors

To minimize data errors when logging data to external memory, consider the following:

- Do not turn off power to the PLC while the SD card is being accessed.
- Do not remove the SD card while the device is being accessed by the PLC.

The following addresses should be used to monitor, access and safely remove an SD card:

Address	Description	Read/Write
SC65	SD Eject	R/W
SC66	SD Delete All	R/W
SC67	SD Copy System	R/W
SC68	SD Ready To Use	R
SC69	SD Write Status	R
SC70	SD Error	R

- Be sure to backup the memory device at regular intervals.
- If you suspect the SD card is bad, you may want to use a PC to re-format the device, or use a known good SD card.
- The number of times the SD card can be written to is limited. Consequently, logging frequently may shorten the service life of the SD card. Using slower sample rates will increase the life of the SD card.



NOTE: An SD card with SLC mode, such as AutomationDirect #MSD-SLC16G, is strongly recommended for increased maximum lifetime write cycles.

Monitoring Available Memory

Each external memory device can be monitored and events can be configured to alert the user when available memory is approaching the maximum capacity of the external memory device. The following internal tags allow external memory devices data to be monitored:

Address	Description	Read/Write
SD63	SD Total Memory Low byte	R
SD64	SD Total Memory High byte	R
SD65	SD Free Memory Low byte	R
SD66	SD Free Memory High byte	R
SD67	SD Used Memory Low byte	R
SD68	SD Used Memory High byte	R
SD69	SD Error Information	R
SD70	SD Log File Number	R

Refer to the CLICK programming software online help files for additional information on system tags and managing data logging devices.

File Name Limitations

There is a limit of 999 log files stored on the SD card. As new log files are created based on a set time or trigger event, these files count against the maximum of 999 files. Consider the rate of new file generation when setting the conditions to start a new file, and monitor the current number of stored files to avoid data loss.

PLC COMMUNICATIONS



In This Chapter...

Introduction.....	4-2
PLC Communication Ports Specifications	4-3
LED Status Indicators.....	4-4
Remote PLC App Configuration and Use	4-6
C2-DCM Intelligent Module Communication Ports Specifications.....	4-7
3 Steps to Using the CLICK PLC Communications	4-8
Typical Communication Applications	4-9
W-1: USB Port Wiring	4-13
W-2: Com Port 2 (RS-232) Wiring	4-14
W-3: Com Port 1 (Ethernet) Wiring.....	4-18
W-4: Com Port 3 Wiring.....	4-20
W-5: C2-DCM Com Port RS-232 Wiring	4-21
W-6: C2-DCM Com Port RS-485 Wiring	4-22
C-1: USB Port Setup.....	4-23
C-2: Com Port 1 (Ethernet) Setup	4-24
C-3: Wireless LAN (WLAN) Setup.....	4-25
C-4: Bluetooth Setup	4-26
C-5: Com Port 2 Setup (Modbus RTU).....	4-27
C-6: Com Port 2 Setup (ASCII)	4-28
C-7: Com Port 3 Setup (Modbus RTU).....	4-29
C-8: Com Port 3 Setup (ASCII)	4-30
C-9: C2-DCM Com Port 1 or 2 Setup (ASCII)	4-31
C-10: C2-DCM Com Port 1 or 2 Setup (Modbus RTU)	4-32
P-1: Modbus Slave (Server) Programming.....	4-33
P-2: Modbus Master Programming (Modbus RTU).....	4-37
P-3: Modbus Client (Modbus TCP) Programming	4-42
P-4: ASCII Receive Programming.....	4-48
P-5: ASCII Send Programming	4-51

Introduction

This chapter explains the communications ability of the CLICK PLUS PLC system for exchanging data between the PLC unit and other connected serial devices. It covers:

- Electrical connections used for communications
- Networking routing between the PLC and other devices,
- Setting the port communication parameters,
- Selecting the protocols and the available data addressing types to use, and
- Ladder logic program instructions that make it all work together.

All CLICK PLUS PLCs have a built-in microB USB port for programming.

The C2-01CPU and C2-03CPU have an RS-232 port, designated Port 2. The port uses a 6-pin RJ12 phone type jack. It is a general purpose port, user configurable, with its communication parameters within CLICK Programming Software, C0-PGMSW. Port 2 can be used as a Modbus RTU master or slave protocol device, or handle ASCII data In or Out (ASCII stands for American Standard Code for Information Interchange and defines a character encoding method for text that is used in computers and other communication devices. Details can be found by doing a search for ASCII on the internet).

The C2-03CPU also has a 3-pin RS-485 port, designated Port 3. Like Port 2, Port 3 is a general purpose port with its communication parameters being user configurable from the programming software. Port 3 can be used as a Modbus RTU master or slave protocol device, or handle ASCII data In or Out.

The C2-01CPU and C2-03CPU have a built-in Ethernet communications port.

The C2-02CPU and C2-03CPU have an antenna port capable of both Bluetooth and WLAN communications.

The CLICK PLUS PLCs can be networked to other CLICK PLCs, data input devices (barcode readers, weight scales, etc.), and/or data output devices (serial printers, serial text displays, etc.). It is also possible to network the CLICK PLUS PLC to other 3rd party PLCs and devices that have the ability to communicate using the Modbus RTU and TCP protocols.

The final part of the PLC Communications chapter contains explanations and examples of the various ways the Send and Receive programming instructions can be used to perform Modbus RTU protocol and ASCII data communications between devices.

There are three different data addressing types that can be selected when using the Modbus RTU protocol from the Send and Receive instructions. They are, CLICK addressing, Modbus 984 addressing, or Modbus HEX addressing. The CLICK addressing makes it convenient to exchange data between CLICK PLCs. The other addressing choices are selected based on the Modbus protocol addressing the networked devices are using. For details on the Modbus protocol, visit www.modbus.org.

NOTE: *The Modbus RTU Master is identified as the device that controls the exchange of data between itself and any connected slave device. There can only be one master on the network. When the CLICK PLC is the master, it is easily identified. It will be the PLC in the network with the Send and/or Receive instructions using the Modbus protocol in its ladder logic program.*



PLC Communication Ports Specifications

The CLICK PLUS PLC units have several built-in communications ports, as shown below.

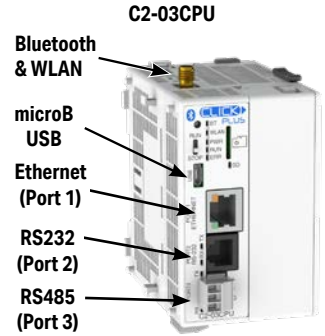
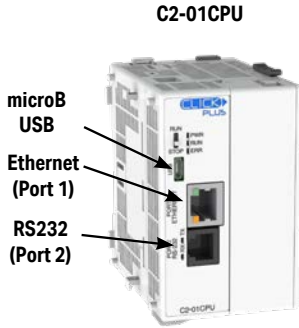

Com Port 1 Specifications	
Use: Programming and Ethernet Communication	
Physical: 8 pin, RJ45, Ethernet	
Communication Speed (Mbps): 10/100	
Protocol: Modbus TCP (client/server), EtherNet/IP Implicit and Explicit (adapter server), DNS, DHCP, NTP, MQTT	

Com Port 2 Specifications	Default
Use: Serial Communication	-
Physical: 6 pin, RJ12, RS-232	-
Communication speed (baud): 2400, 4800, 9600, 19200, 38400, 57600, 115200	38400
Parity: odd, even, none	Odd
Station Address: 1 to 247	1
Data length: 8 bits (Modbus RTU) or 7, 8 bits (ASCII)	8 bits
Stop bit: 1,2	1
Protocol: Modbus RTU (master/slave) or ASCII in/out	Modbus RTU

Com Port 3 Specifications	Default
Use: Serial Communication	-
Physical: 3 pin, RS-485	-
Communication speed (baud): 2400, 4800, 9600, 19200, 38400, 57600, 115200	38400
Parity: odd, even, none	Odd
Station Address: 1 to 247	1
Data length: 8 bits (Modbus RTU) or 7, 8 bits (ASCII)	8 bits
Stop bit: 1,2	1
Protocol: Modbus RTU (master/slave) or ASCII in/out	Modbus RTU

Port 1
8 pin RJ45 Phone Type Jack

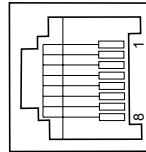

Port 1 Pin Descriptions		
1	TX+	Transmit Data (+)
2	TX-	Transmit Data (-)
3	RX+	Receive Data (+)
4	NC	Not connected
5	NC	Not connected
6	RX-	Receive Data (-)
7	NC	Not connected
8	NC	Not connected

Port 2
6 pin RJ12 Phone Type Jack

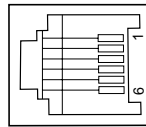

Port 2 Pin Descriptions		
1	0V	Power (-) connection (GND)
2	5V	Power (+) connection
3	RXD	Receive data (RS-232)
4	TXD	Transmit data (RS-232)
5	RTS	Request to send
6	0V	Power (-) connection (GND)

Port 3
3 Pin Terminal Block

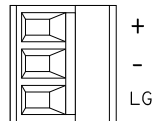

Port 3 Pin Descriptions		
1	+ (plus)	Signal A (RS-485)
2	- (minus)	Signal B (RS-485)
3	LG	Logic Ground(0V)

See Chapter 2: *Specifications* for the microB USB port and antenna port specifications.

LED Status Indicators

POWER LED (Green)	
On	Power Good
Blink	USB Low Power Mode
Off	Power Failure

RUN LED (Green)	
On	CPU Run Mode
Blink	Initializing Modules
Off	CPU Program Mode

ERROR LED (RED)	
On	Self Diagnostic Error
Blink	Self Diagnostic Warning
Off	No Error

LNK/ACT LED (Green)	
On	Connected to the network
Blink	Communicating
Off	Disconnected from the network

100MBIT LED (Orange)	
On	Communicating at 100Mbps
Off	Communicating at 10Mbps or disconnected from the network

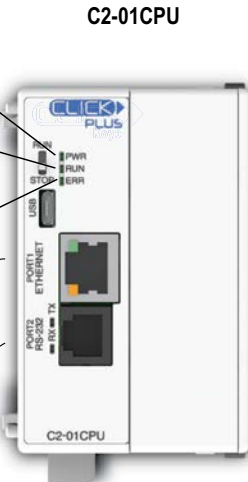

TX & RX LED (Green)	
On	Com Port Data Active
Off	No Communication

WLAN LED (Green)	
On	Link
Blink	Activity
Off	No Link

POWER LED (Green)	
On	Power Good
Blink	USB Low Power Mode
Off	Power Failure

RUN LED (Green)	
On	CPU Run Mode
Blink	Initializing Modules
Off	CPU Program Mode

ERROR LED (RED)	
On	Self Diagnostic Error
Blink	Self Diagnostic Warning
Off	No Error

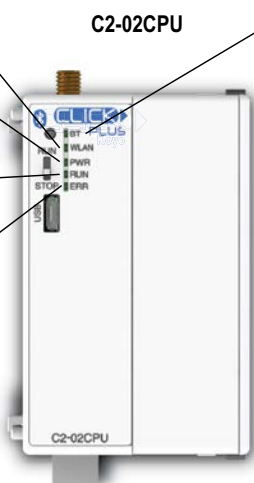

BLUETOOTH LED (Blue)	
On	Link
Blink	Activity (per packet)
Blink	Pairing Mode (500ms flash)
Blink	Disabled in PLC* (200ms flash)
Off	No Link

*Error - Bluetooth disabled in PLC (SC60) is On. Pairing mode disabled.

LED Status Indicators (continued)

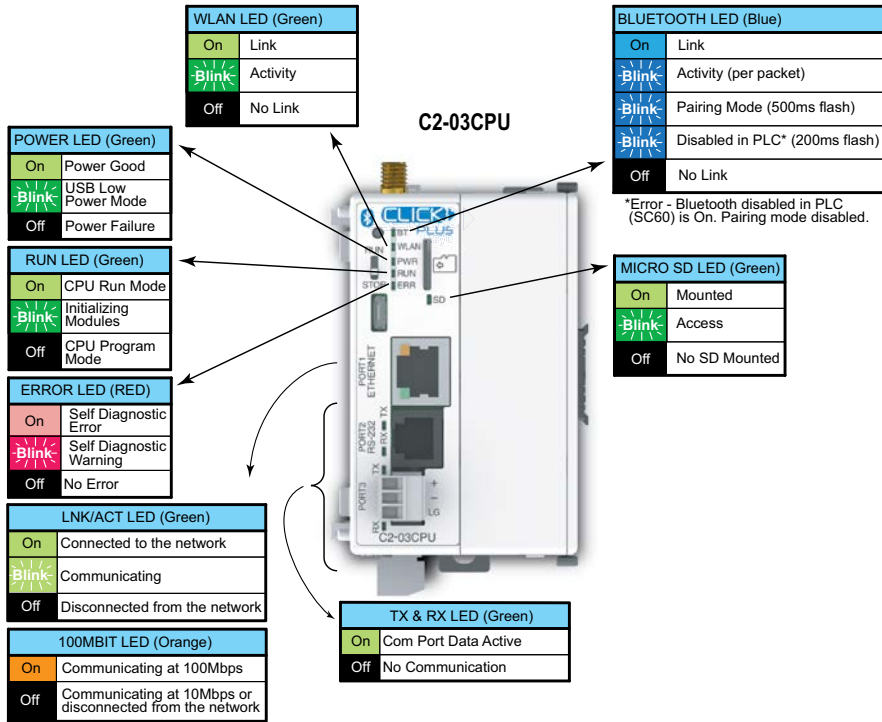

DirectLogic Devices That Do Not Work With CLICK PLCs

The CLICK PLUS PLC does not support K-sequence protocol, so the following DirectLogic devices do not work with the CLICK PLUS PLC:



D2-HPP



D4-HPP-1



DV-1000

Remote PLC App Configuration and Use

The following CLICK PLCs support the iOS and Android Remote PLC App:

- C0-10xxx-x
- C0-11xxx-x
- C0-12xxx-x
- C2-01CPU(-2)
- C2-02CPU(-2)
- C2-03CPU(-2)



The CLICK Remote PLC capability is new in Version 3.60 of the CLICK software and firmware. It enables a user to access data registers and PLC status information using a mobile phone or tablet running either iOS or Android. This enables the user to perform machine troubleshooting and setup operations when access to the programming PC can be awkward or inconvenient.

CLICK Remote PLC app is not intended to replace an operator interface for standard machine operations; instead it provides an additional tool to simplify troubleshooting and configuration of your system.

1. To use Remote PLC, you must either:
 - a. Connect your PLC to a network with a Wi-Fi access point.-OR-
 - b. Enable Bluetooth on your C2-02CPU or C2-03CPU.
2. Configure a Data Monitor with the Addresses you wish to monitor and user security.

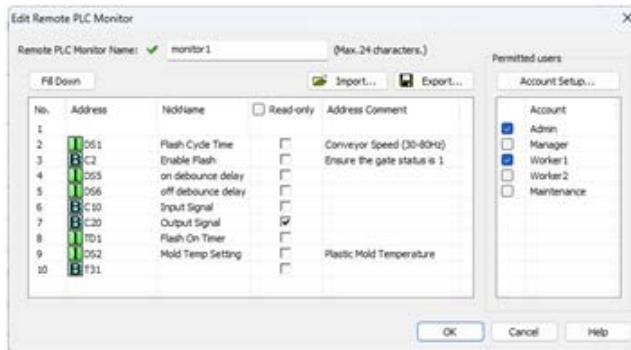

3. Set up users with access to up to 32 data monitors.
4. Download the Remote PLC App for your mobile device:

Apple App Store



Google Play (Android)



C2-DCM Intelligent Module Communication Ports Specifications

The C2-DCM Option Slot module has two serial communications ports, as shown below.

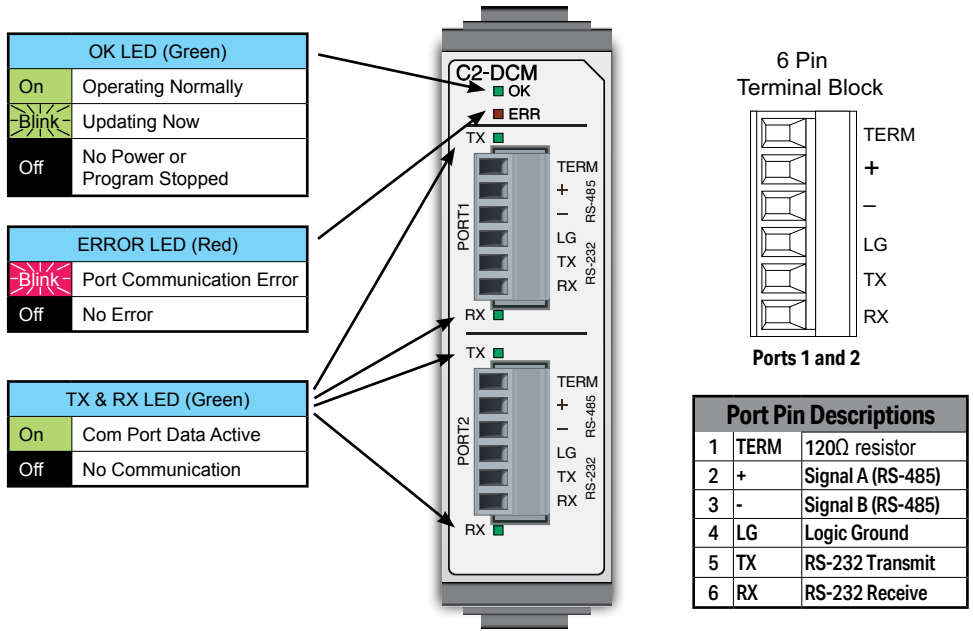

Port Specifications	
Number of Ports	2
Port Types	RS-232, RS-485 (2-wire)
Supported Protocols	Modbus RTU, ASCII (user-defined)
Communications Parameters	<ul style="list-style-type: none"> Baud rate: 2400, 4800, 9600, 19200, 38400, 57600, 115.2k bps Data bit: 7 bits, 8 bits Parity: None, Odd, Even Stop bit: 1 bit, 2 bits Flow Control: None
RS-485 Terminating Resistor	120Ω, Internal
Status Indicator LEDs	OK, ERR, TX (per port), RX (per port)

Terminal Block Specifications	
Connector Type	Pluggable Terminal Block
Number of Pins	6 (x2 terminal blocks)
Pitch	3.50 mm
Wire Size Range	16–28 AWG
Stripping Length	7.0 mm
Wire Specification	Lead-free, heat resistant, polyvinyl chloride insulated copper wire, rated over 80°C
Screw Thread	M2.0
Tightening Torque	2.0 – 2.2 lb-inch [0.22 – 0.25 N·m]
Recommended Cable	Shielded cable (AutomationDirect Q8105-1 or Q8302-1 recommended)

3 Steps to Using the CLICK PLC Communications

We offer an easy 3-step method for using the communication features of the CLICK PLC.

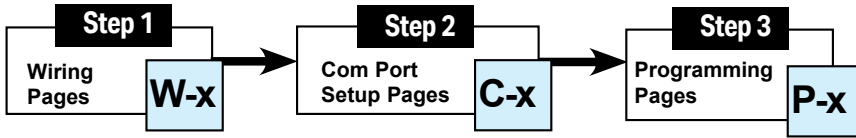

The following pages show the devices that you may connect to the CLICK PLC Com ports. Use the table below to locate information on communications for your particular application. As you can see in the table, each step has subcategories. For each step, find the subcategory description that best describes your application. Use the subcategory references (W-x, C-x, and P-x.) to find more information on these topics in this chapter. See the example below.

CLICK PLC Communications			
Step	Subcategory Reference	Subcategory Description	Page
Step 1 Wiring	W-1	USB	4-12
	W-2	Com port 2 (RS-232)	4-13
	W-3	Com port 1 (Ethernet)	4-17
	W-4	Com port 3 (RS-485)	4-19
	W-5	C2-DCM Port 1 or 2 (RS-232)	4-20
	W-6	C2-DCM Port 1 or 2 (RS-485)	4-21
Step 2 Com Port Setup	C-1	USB setup	4-22
	C-2	Com port 1 (Ethernet) setup	4-23
	C-3	WLAN setup	4-24
	C-4	Bluetooth setup	4-25
	C-5	Com port 2 setup (Modbus RTU)	4-26
	C-6	Com port 2 setup (ASCII)	4-27
	C-7	Com port 3 setup (Modbus RTU)	4-28
	C-8	Com port 3 setup (ASCII)	4-29
	C-9	C2-DCM Port 1 or 2 setup (RS-232)	4-30
	C-10	C2-DCM Port 1 or 2 setup (RS-485)	4-31
Step 3 Programming	P-1	Modbus Slave (Server) programming	4-32
	P-2	Modbus Master programming (Modbus RTU)	4-36
	P-3	Modbus Client programming (Modbus TCP)	4-41
	P-4	ASCII Receive programming	4-47
	P-5	ASCII Send programming	4-50

Example:

To connect a barcode reader that sends ASCII data to Com Port 2:



Typical Communication Applications

The diagrams on the following four pages illustrate the typical uses for the CLICK PLUS PLC's communication ports. Typical serial communication applications are continued on the next three pages.

Port 2 (RS-232) – Modbus RTU Slave Mode Only

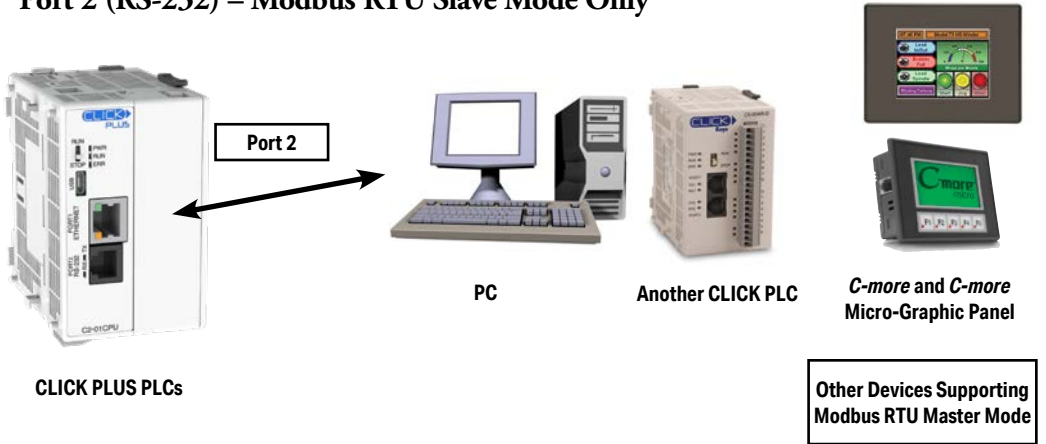

W-2 C-5 P-1



TIP: C-more Micro-Graphic panels (monochrome models only) can get 5VDC power from RS-232 Port.

C-more Micro-Graphic Panel (Monochrome models only)

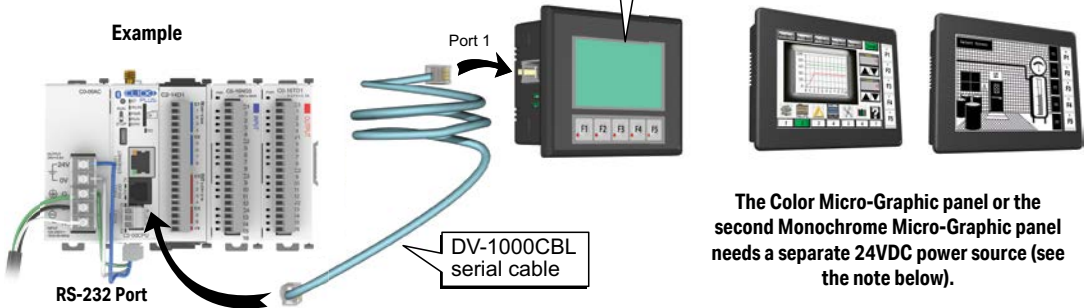

NOTE: CLICK's RS-232 port can provide 5VDC to power one monochrome Micro-Graphic panel. If two C-more Micro-Graphic panels are connected to both ports, then at least one of the panels must be powered by a C-more Micro DC power adapter, EA-MG-P1 or EA-MG-SP1, or another 24VDC power source. Color C-more Micro-Graphic panels must also be powered from a separate 24VDC source.

Port 1 (Ethernet) – Modbus TCP

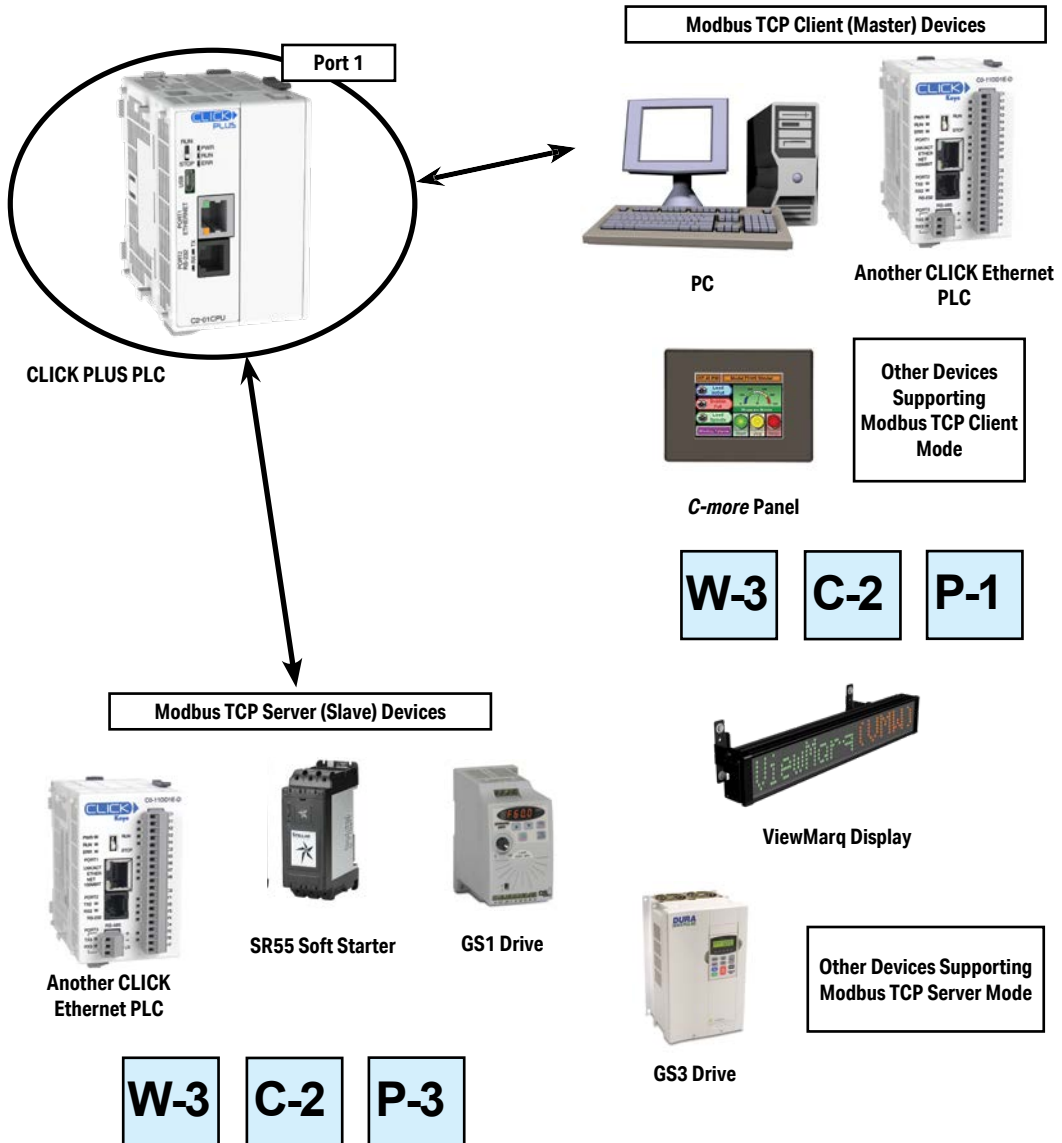

Port 2 (RS-232) – Modbus RTU or ASCII

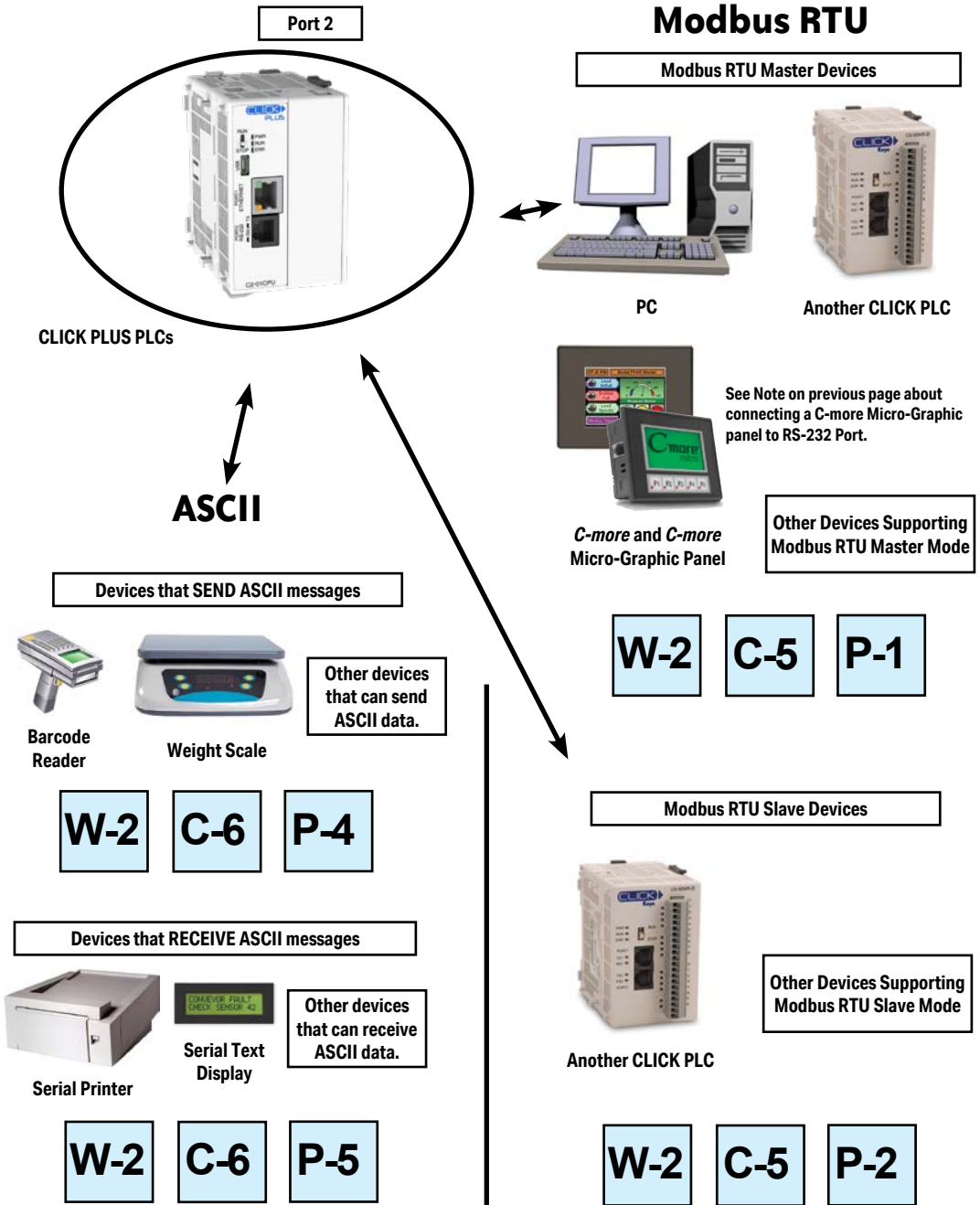

Port 3 (RS-485 – Modbus RTU or ASCII)

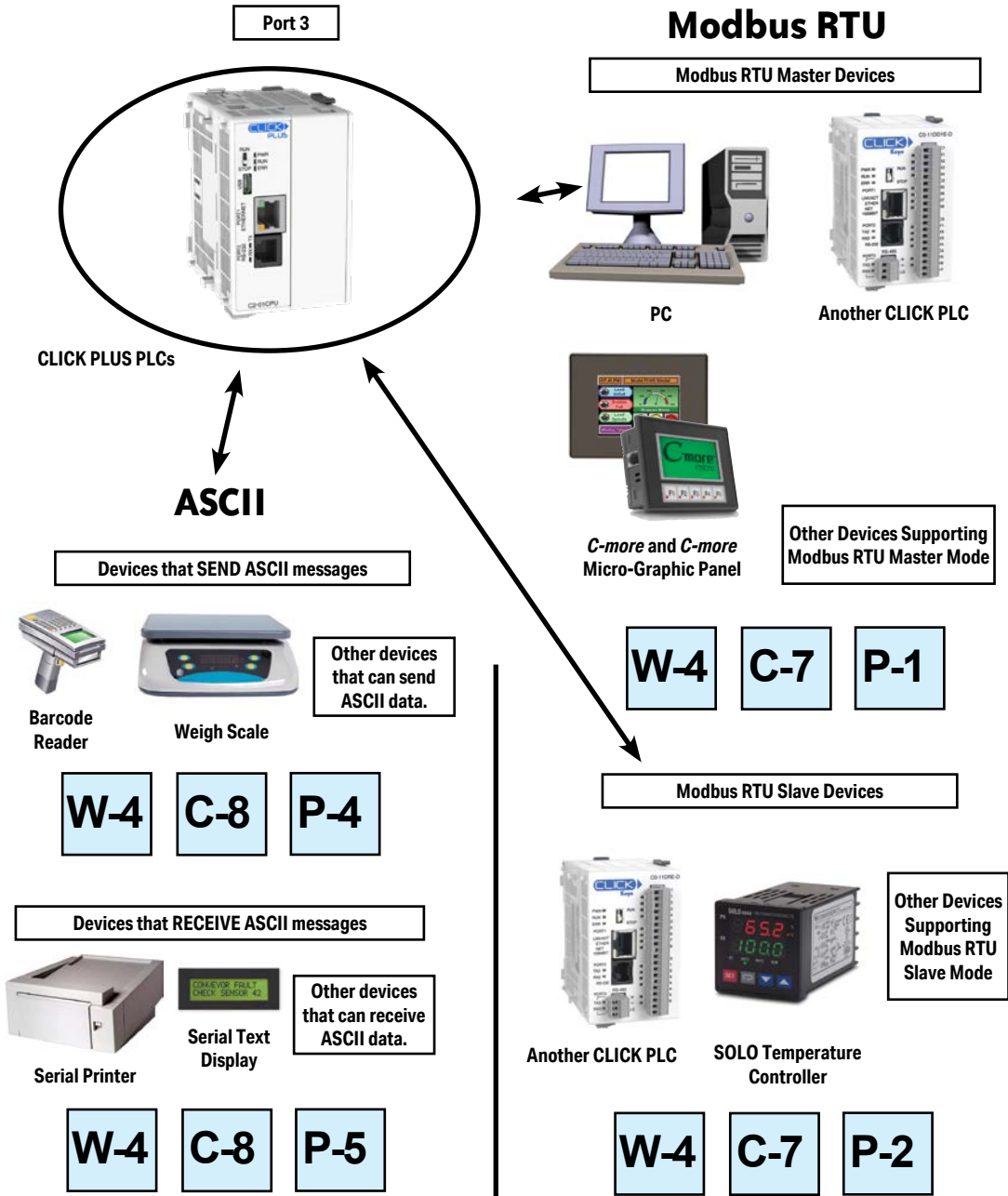

W-1 W-1: USB Port Wiring

USB Port wiring pinout is shown below.

USB Port Pin Descriptions		
1	VBUS	5V Power supply in
2	D-	Differential signal -
3	D+	Differential signal +
4	NC	Not connected (ID not used)
5	GND	Ground

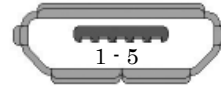

Wiring Strategy

Connect any CLICK PLUS CPU to a USB A port on a Windows PC, using cable USB-CBL-AMICB6 or equivalent.

NOTE: The CLICK PLUS CPU can be supplied 5VDC power from a PC over the USB port when no 24VDC power is applied, with the following capabilities and restrictions



Available:

- Programming over Port 1, Port 2, and Port 3
- Firmware update
- CLICK Factory Default and CLICK Project Loader Tools
- Modbus Server/Slave over Port 1, Port 2, and Port 3
- Option Slot module can be identified in software

Not Available:

- RUN mode is disabled
- WLAN and Bluetooth are disabled
- Access to the microSD Card from software is disabled

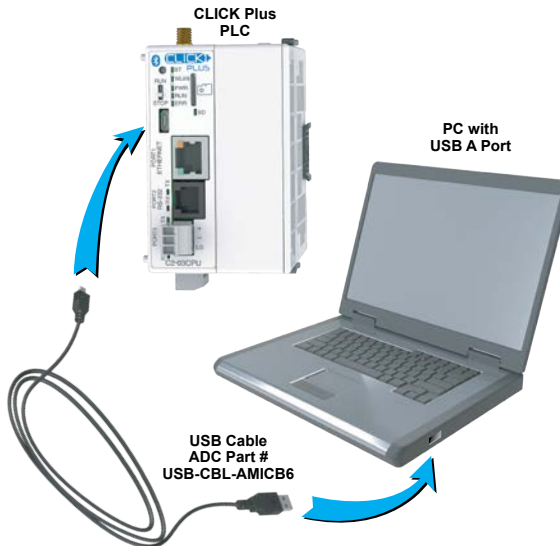

W-2

W-2: Com Port 2 (RS-232) Wiring

Com Port 2 wiring pinout is shown below.

6 pin RJ12 Phone
Type Jack

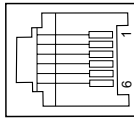

Port 2 Pin Descriptions		
1	0V	Power (-) connection (GND)
2	5V	Power (+) connection
3	RXD	Receive data (RS-232)
4	TXD	Transmit data (RS-232)
5	RTS	Request to send
6	0V	Power (-) connection (GND)



NOTE: Com port 2 can provide 5VDC; however, the 5VDC power can be used only for the C-more Micro-Graphic panel. AutomationDirect does not guarantee that the CLICK PLUS PLC will work correctly when any other device uses 5VDC from these Com ports. Please also remember these Com ports can provide enough power only for one C-more Micro-Graphic panel.

Wiring Strategy

The following pages cover five case scenarios for connecting com port 2:

Case 1: Connect Com Port 2 to a PC.

Case 2: Connect Com Port 2 to another CLICK PLC.

Case 3: Connect Com Port 2 to a C-more or C-more Micro-Graphic panel.

Case 4: Connect Com Port 2 to an RS-422 or RS485 port on another device(s).

Case 5: Connect Com Port 2 to an RS-232 port on another device.

Case 1: Connect Com Port 2 to a PC.

You can connect Com Port 2 to a serial com port or USB port on the PC.

1. Connect to a serial port

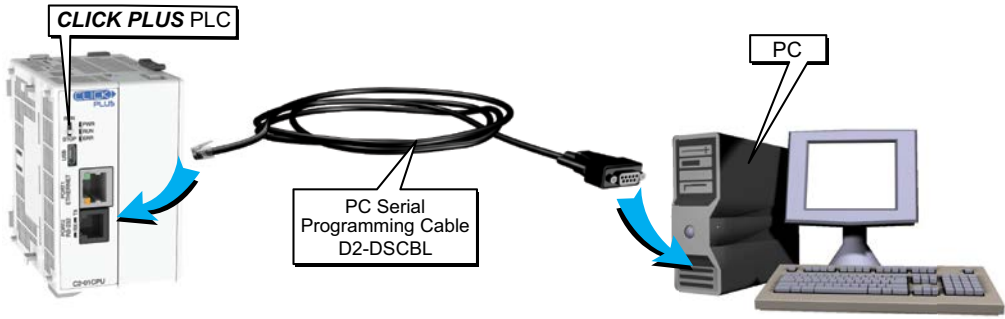

Case 2: Connect Com Port 2 to another CLICK PLC

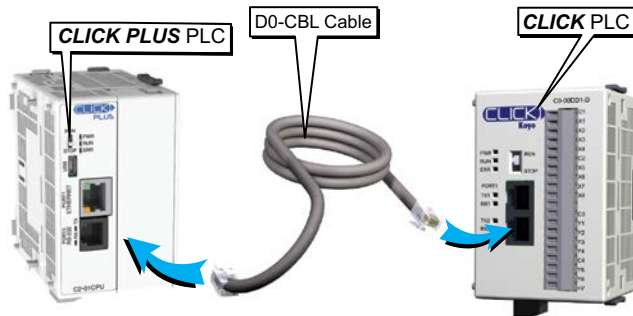

You can use cable D0-CBL.

In this configuration, one of the CLICK/CLICK PLUS PLC units needs to be the network master and the other is the network slave. Connect the D0-CBL on Com Port 2 on the master PLC unit side.



WARNING: The ZL-RJ12-CBL-2 cable cannot be used for this purpose.

Case 3: Connect Com Port 2 to a C-more or C-more Micro-Graphic panel

Please use the following cables to make your connections.

C-more Graphic Panel	Cable Part Number
C-more Touch panels	EA-2CBL (3m) or OP-2CBL (2m)
C-more Micro-Graphic Panels	DV-1000CBL if the panel receives 5VDC power from the CLICK PLC com port. (Monochrome panels only; color panels must be powered from a separate 24VDC power source. Please refer to the note on page 4-6 for details.)
	EA-2CBL (3m) or OP-2CBL (2m) if the panel receives 24VDC power from other source.

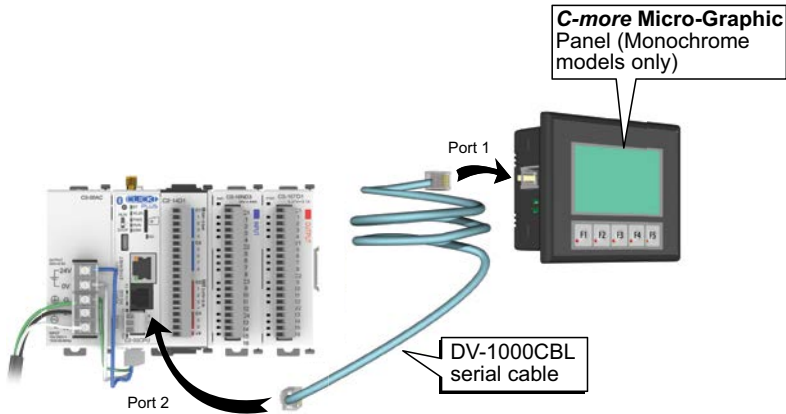

Case 4: Connect Com Port 2 to an RS-422 or RS485 port on another device(s).

You need a RS-232 to RS-422/485 converter in this case. We recommend our FA-ISOCOCON as the converter.

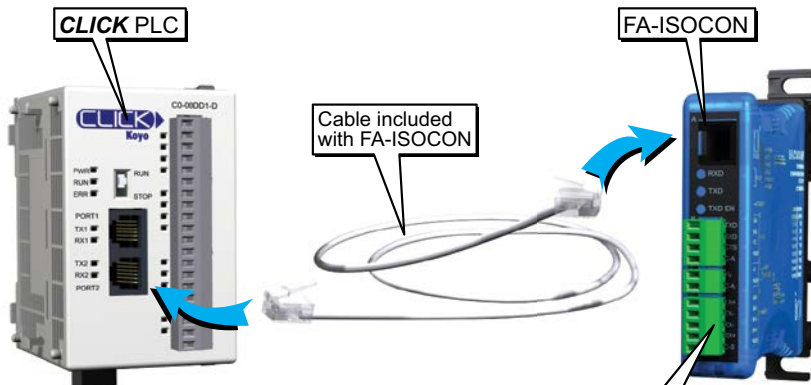

The recommended cables to connect the FA-ISOCOCON to other devices:

- Belden 8103 for the RS-422
- Belden 9842 for 2-wire RS-485
- Belden 9843 for 4-wire RS-485

Case 5: Connect Com Port 2 to an RS-232 port on another device

You need to cross the RTD and TXD signal lines and connect 0V on both com ports.

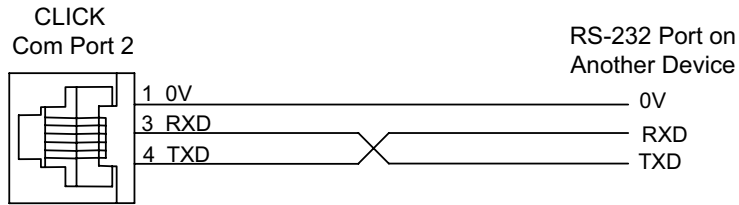

You can make your own cable. However, we offer two products that make your wiring much easier:

1. ZIPLink feed-through module and cable

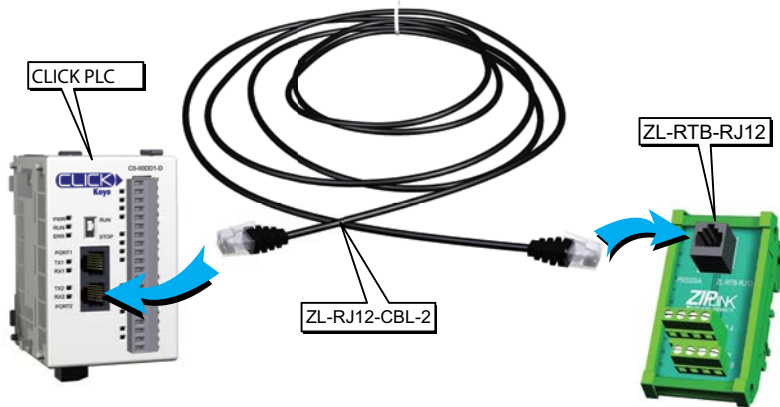

2. ZIPLink pig-tail cable

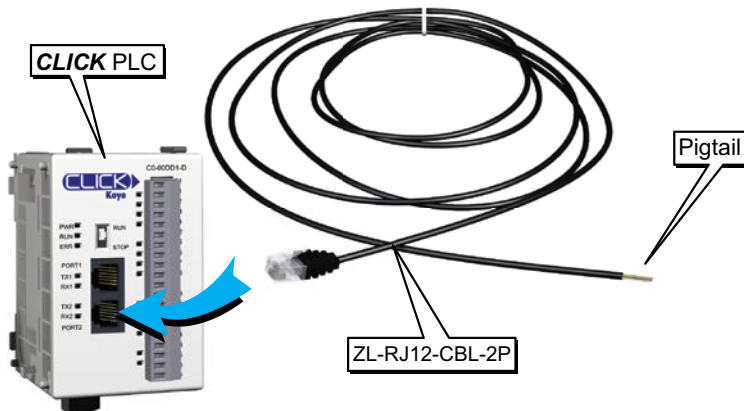

W-3 W-3: Com Port 1 (Ethernet) Wiring

Com Port 1 (Ethernet) supports 10/100 Base-T Ethernet with an RJ-45 style connector.

8 pin RJ45 Phone Type Jack

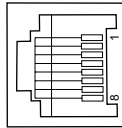

Port 1 Pin Descriptions		
1	TX+	Transmit Data (+)
2	TX-	Transmit Data (-)
3	RX+	Receive data (+)
4	NC	Not connected
5	NC	Not connected
6	RX-	Receive Data (-)
7	NC	No connection
8	NC	No connection

You can use both straight and cross over cables with Com Port 1.

Wiring Strategy

- There are two wiring methods to connect to devices which support Modbus TCP protocol.
- Case 1: Connect Com Port 1 to a device that supports Modbus TCP protocol directly such as a PC.
- Case 2: Connect Com Port 1 to other devices that support the Modbus TCP protocol via a switch or hub.

Case 1: Connect Com Port 1 to a device that supports the Modbus TCP protocol directly such as a PC.

In this illustration a PLC unit is connected directly to a PC.

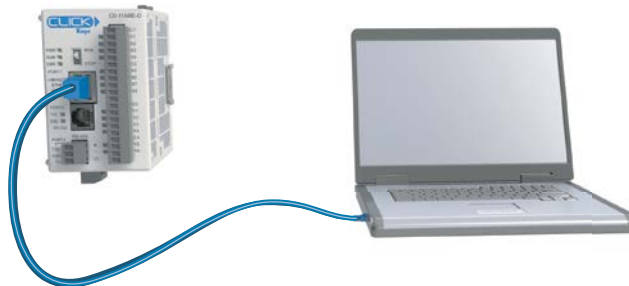

Case 2: Connect Com Port 1 to other devices that support the Modbus TCP (client/server) protocol via a switch or hub.

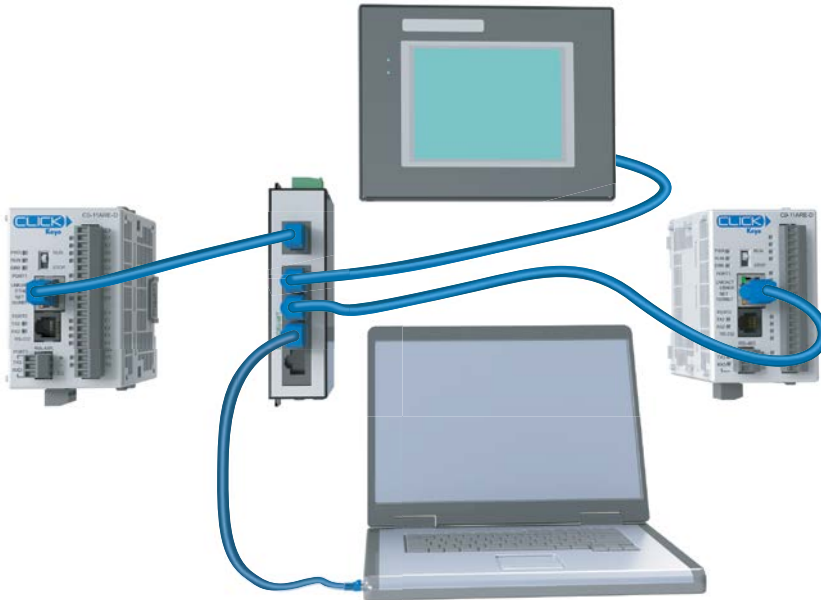

NOTE: Com Port 1 can communicate with any number of servers (slaves) using the Receive and/or Send instructions. However, Com Port 1 can communicate with up to 4 servers at the same time. If the ladder program has sent a message to 4 different servers and tries to send a message to another server, the CLICK PLUS PLC unit disconnects the first server and establishes a connection with the new server, maintaining a total of 4 servers.



NOTE: Com Port 1 can communicate with up to 3 clients (masters). If a client attempts to establish communication with Com Port 1 while it is communicating with 3 clients, the CLICK PLUS PLC unit replies with an error to the fourth client.

W-4: Com Port 3 Wiring

Com Port 3 supports 2-wire RS-485.

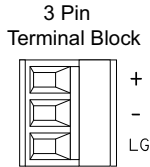

Port 3 Pin Descriptions	
1	+ (Plus) Signal A (RS-485)
2	- (Minus) Signal B (RS-485)
3	LG Logic Ground (0 V)

Wiring Strategy

You need to connect all + signal terminals in the network together. You will also need to connect all - signal terminals together. It is optional to connect the logic ground.

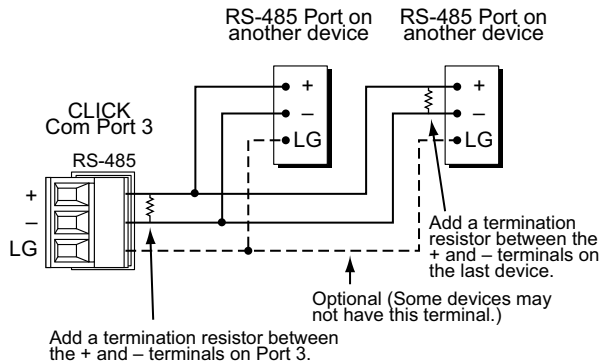

NOTE: The resistance of the termination resistors needs to match the impedance of the communication cable.



NOTE: Use a repeater if connecting more than 32 slaves to Port 3.

W-5 W-5: C2-DCM Com Port RS-232 Wiring

C2-DCM Com Port wiring pinout is shown below.

6 Pin
Terminal Block

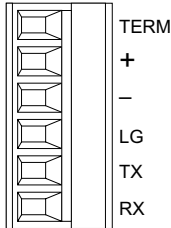

Ports 1 and 2

C2-DCM Port Pin Descriptions		
1	TERM	not used for RS-232
2	+ (Plus)	not used for RS-232
3	- (Minus)	not used for RS-232
4	LG	Logic Ground (0 V)
5	TX	RS-232 Transmit
6	RX	RS-232 Receive

Wiring Strategy

You need to cross the RX and TX signal lines and connect 0V on both com ports.

You can make your own cable. However, we offer pigtail cables with prewired connectors for many AutomationDirect products. Please check www.automationdirect.com for compatible cables.

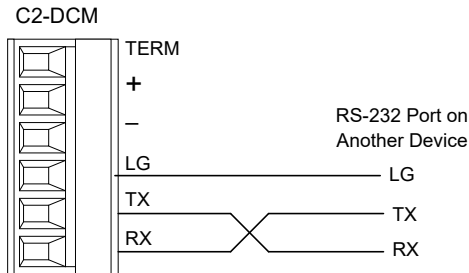

W-6 W-6: C2-DCM Com Port RS-485 Wiring

The C2-DCM com ports support 2-wire RS-485.

6 Pin Terminal Block

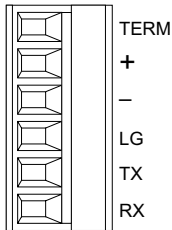

Ports 1 and 2

C2-DCM Port Pin Descriptions		
1	TERM	120Ω resistor
2	+ (Plus)	Signal A (RS-485)
3	- (Minus)	Signal B (RS-485)
4	LG	Logic Ground (0 V)
5	TX	not used for RS-485
6	RX	not used for RS-485

Wiring Strategy

You need to connect all + signal terminals in the network together. You will also need to connect all – signal terminals together. It is optional to connect the logic ground.

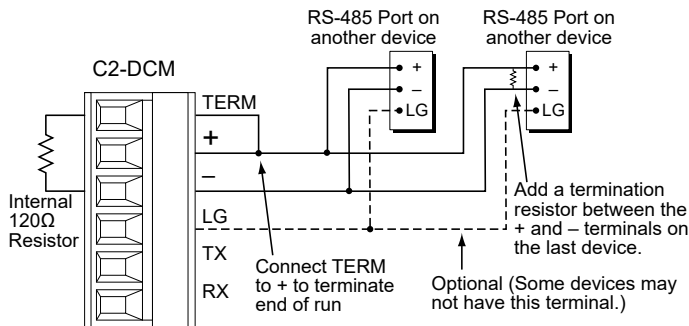

NOTE: The C2-DCM ports include an internal 120Ω internal resistor between TERM and - (Minus). When the C2-DCM is at the end of an RS-485 run, connect TERM and + (Plus) to terminate the line.



NOTE: The resistance of the termination resistors needs to match the impedance of the communication cable.



NOTE: Use a repeater if connecting more than 32 slaves.

C-1 C-1: USB Port Setup

The CLICK PLUS USB port is only used to connect to the CLICK programming software. When a CLICK PLUS device is first connected to a USB port on a Windows PC, a driver is loaded to allow the CLICK PLUS device to emulate a standard serial port. The CLICK PLUS will show up as a USB Serial Device in under Ports in Windows Device Manager.

To connect via USB port, click Connect in the PLC menu, then select USB as the port type. Select the COM port assigned to the USB Serial Device. All other parameters can be left at their default settings.

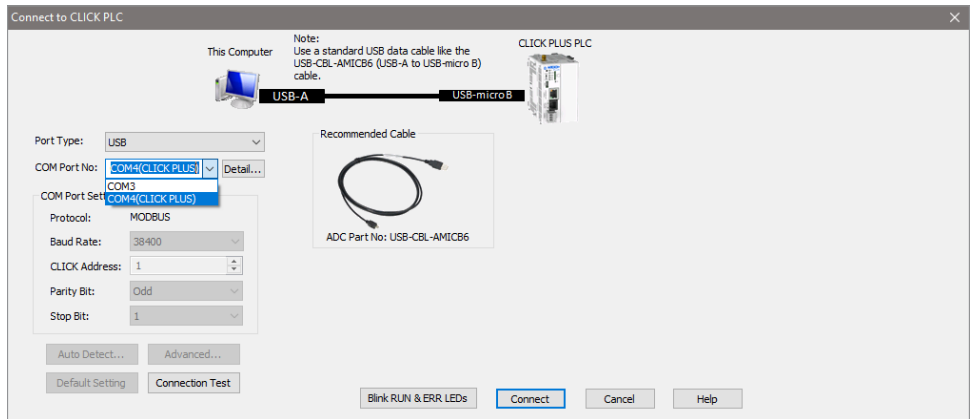

C-2 C-2: Com Port 1 (Ethernet) Setup

Select the Function tab located in the Navigation window of the CLICK Programming Software and double click “Com Port 1 Setup” as shown below.

The Com Port Setup Details dialog box will come into view as shown below.

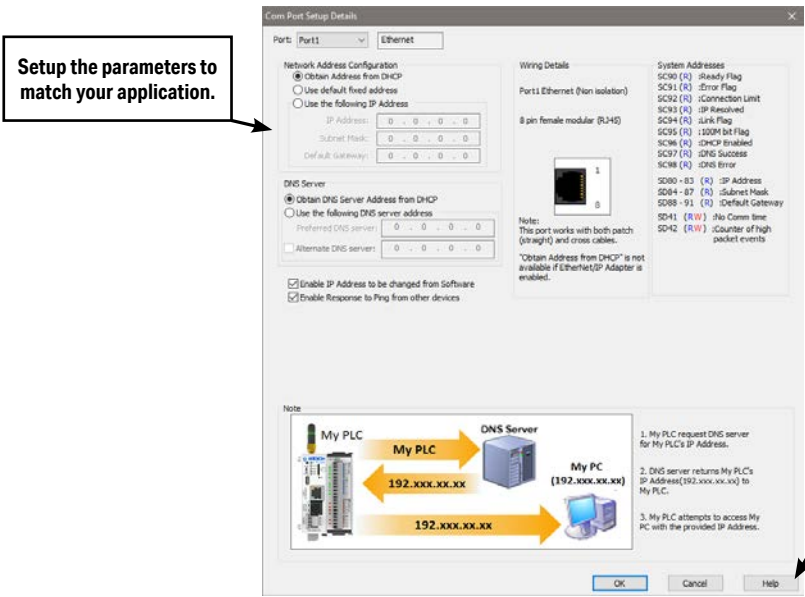
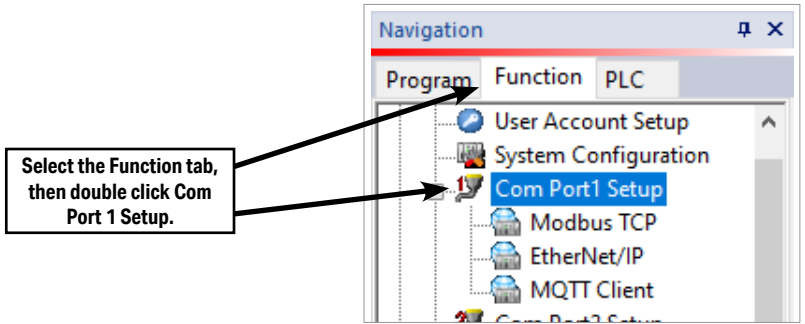

NOTE: The communication port settings are saved in the project file. The project must be transferred to the CLICK PLUS PLC in order for any port setting changes to take effect.

C-3 C-3: Wireless LAN (WLAN) Setup

Select the **Function** tab located in the Navigation window of the CLICK Programming Software and double click “Com Port 1 Setup” as shown below.

The Com Port Setup Details dialog box for the WLAN will come into view as shown below.

Select the Function tab, then double click Wireless Port.

Setup the parameters to match your application.

Click the Help button for online Com Port Setup Details help.

The screenshot shows the 'Navigation' window with the 'Function' tab selected. The 'Wireless Port' option is highlighted. Below it, the 'Com Port Setup Details' dialog box is open, showing various configuration options for the WLAN, including IP address, DNS server, and wireless LAN basic configuration. A diagram at the bottom of the dialog box illustrates the communication flow between a PLC, a DNS server, and a PC.

NOTE: The communication port settings are saved in the project file. The project must be transferred to the CLICK PLUS PLC in order for any port setting changes to take effect.



C-4 C-4: Bluetooth Setup

The Bluetooth connection available on certain CLICK PLUS CPUs is used for initial setup and provisioning of a wireless network connection and for connecting to the Remote PLC App. It provides a method to get a CLICK PLUS CPU connected to a wireless network so that the CLICK programming software on a PC can find the device, finish the setup and load a project.

The process for Bluetooth connection and WLAN provisioning is discussed in Chapter 1, Getting Started. For further information, please see the Bluetooth help topic in the CLICK programming software.

C-5 C-5: Com Port 2 Setup (Modbus RTU)

Select the Function tab located in the Navigation window and double click Com Port2 Setup as shown below.

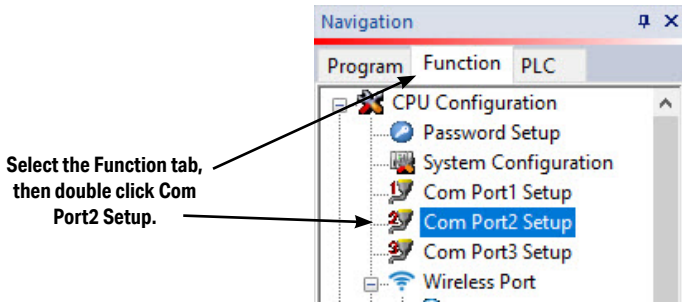

Select the Function tab, then double click Com Port2 Setup.

The Com Port Setup Details dialog box will come into view as shown below.

Find the Basic Configuration section in the dialog box and set up the parameters to match other devices in the same network. The dialog box also has a section named Advanced Configuration.

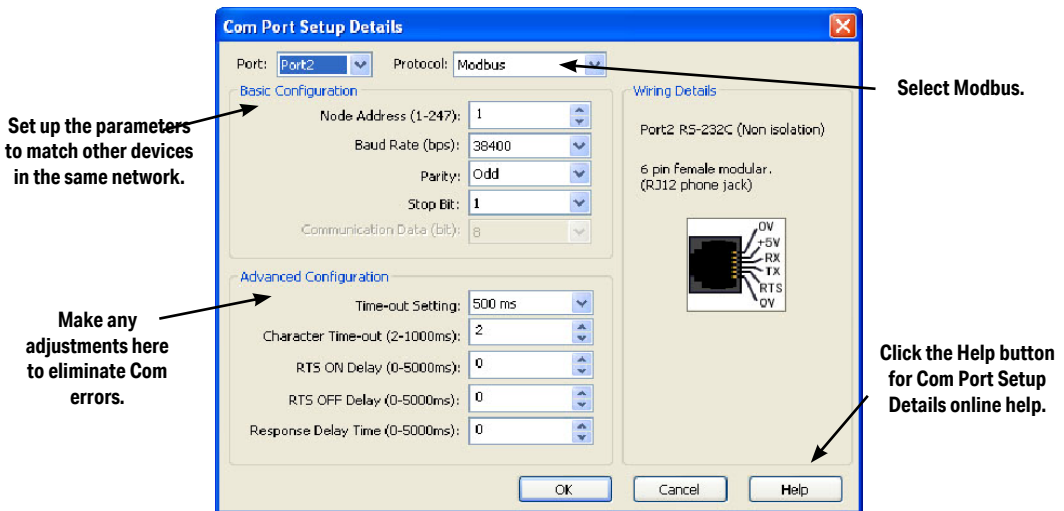

Set up the parameters to match other devices in the same network.

Make any adjustments here to eliminate Com errors.

Select Modbus.

Click the Help button for Com Port Setup Details online help.

You may need to make adjustments to these parameters to overcome communication errors which may occur.



TIP: The communication port settings are saved in the project file. The project must be transferred to the CLICK PLUS PLC in order for any port setting changes to take effect.

C-6: Com Port 2 Setup (ASCII)

Select the Function tab located in the Navigation window and double click Com Port2 Setup as shown below.

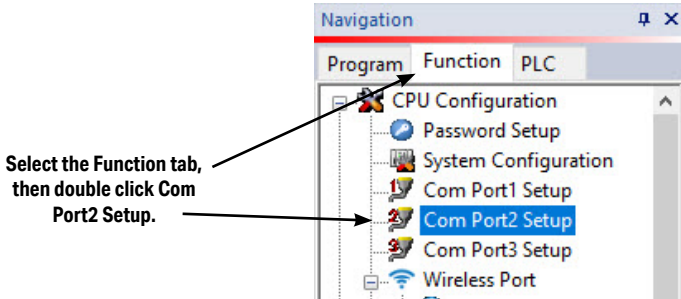

The Com Port Setup Details dialog box will come into view as shown below.

Find the Basic Configuration section in the dialog box and set up the parameters to match the

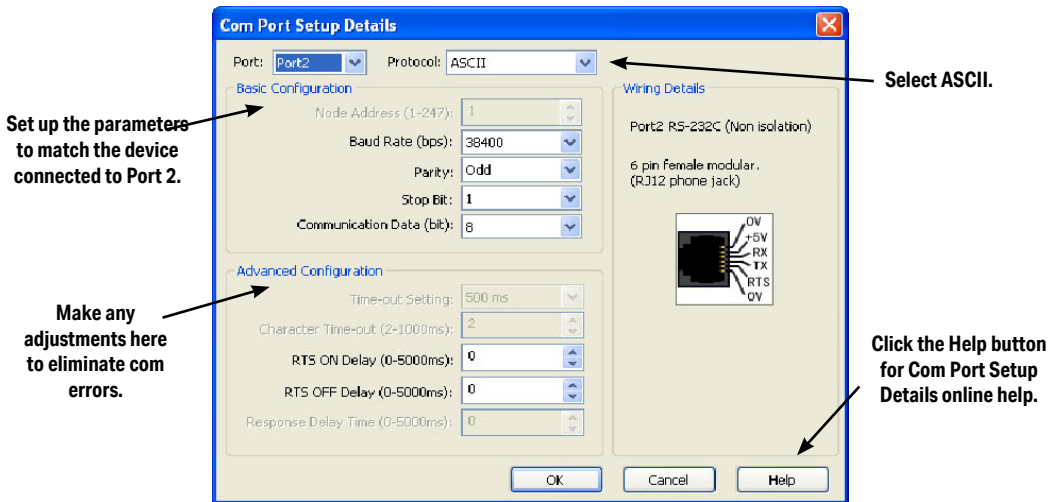

device connected to Port 2. The dialog box also has a section named Advanced Configuration. You may need to make adjustments to these parameters to overcome communication errors which may occur.



TIP: The communication port settings are saved in the project file. The project must be transferred to the CLICK PLUS PLC in order for any port setting changes to take effect.

C-7 Com Port 3 Setup (Modbus RTU)

Select the Function tab located in the Navigation window and double click Com Port3 Setup as shown below.

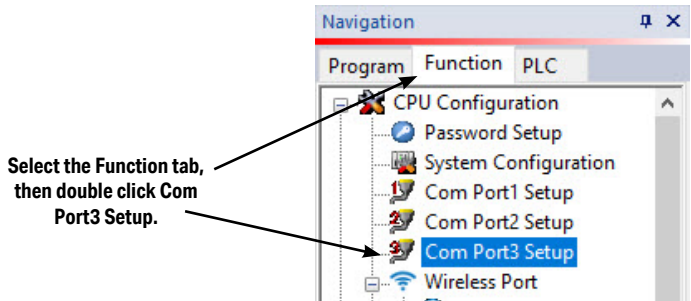

The Com Port Setup Details dialog box will come into view as shown below.

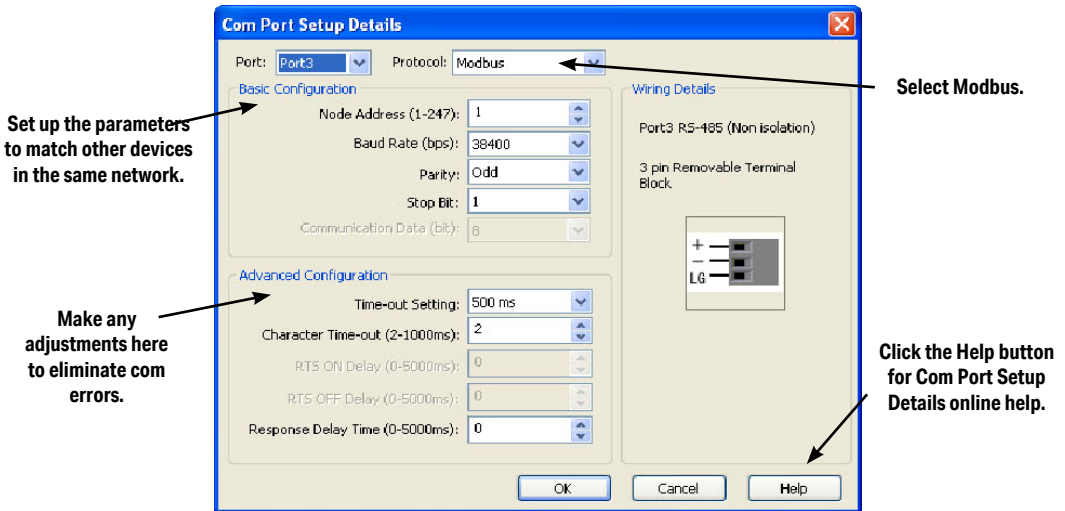

Find the Basic Configuration section in the dialog box and set up the parameters to match other devices in the same network. The dialog box also has a section named Advanced Configuration. You may need to make adjustments to these parameters to overcome communication errors which may occur.



TIP: The communication port settings are saved in the project file. The project must be transferred to the CLICK PLUS PLC in order for any port setting changes to take effect.

C-8 C-8: Com Port 3 Setup (ASCII)

Select the Function tab located in the Navigation window and double click Com Port3 Setup as shown below.

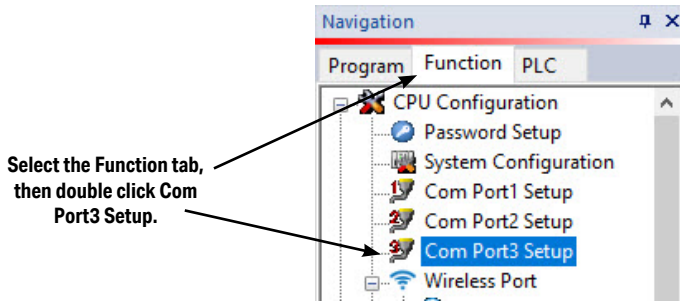

The Com Port Setup Details dialog box will come into view as shown below.

Find the Basic Configuration section in the dialog box and set up the parameters to match the

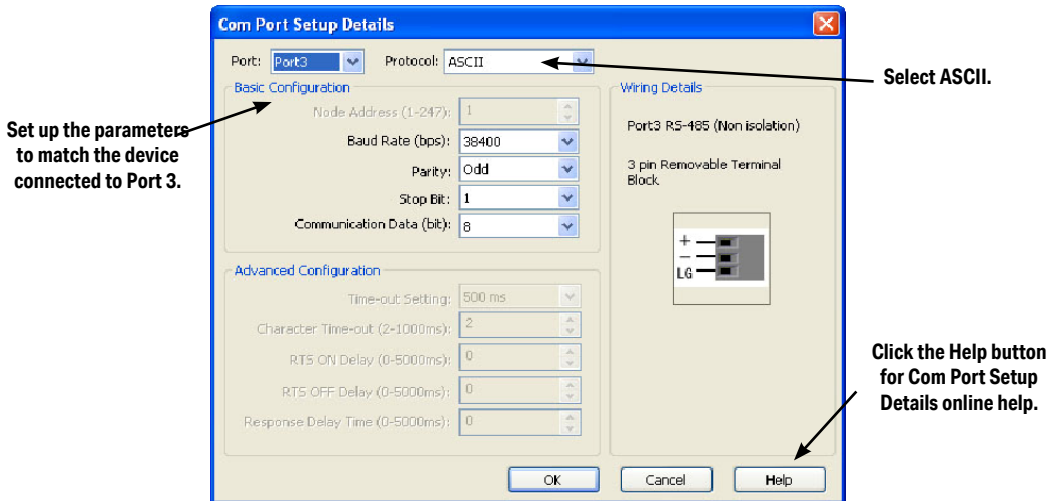

device connected to Port 3.



TIP: The communication port settings are saved in the project file. The project must be transferred to the CLICK PLUS PLC in order for any port setting changes to take effect.

C-9: C2-DCM Com Port 1 or 2 Setup (ASCII)

Select the Function tab located in the Navigation window and double click Com Port1 Setup or Com Port2 Setup under the Slot0 or Slot1 Data Communication Module, as shown below.

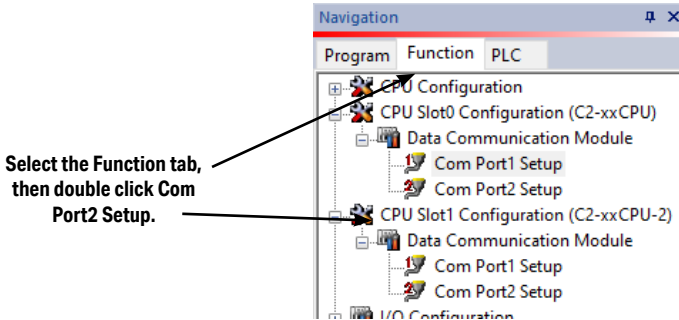

Select the Function tab, then double click Com Port2 Setup.

The Com Port Setup Details dialog box will come into view as shown below.

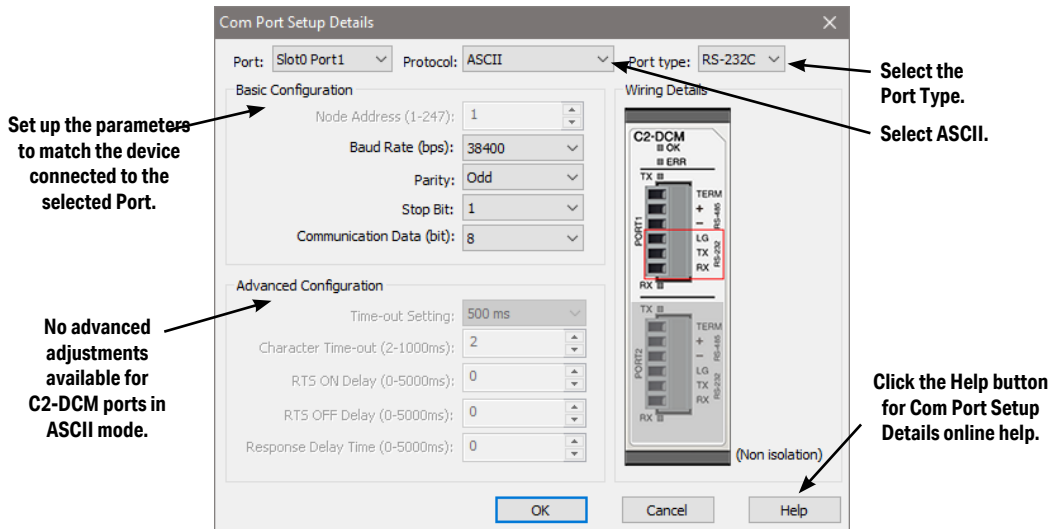

Set up the parameters to match the device connected to the selected Port.

No advanced adjustments available for C2-DCM ports in ASCII mode.

Select the Port Type.
Select ASCII.

Click the Help button for Com Port Setup Details online help.

Select your Port type and Protocol. Find the Basic Configuration section in the dialog box and set up the parameters to match the device connected to the port. The dialog box also has a section named Advanced Configuration, but no advanced configuration parameters are available in ASCII mode.



TIP: The communication port settings are saved in the project file. The project must be transferred to the CLICK PLUS PLC in order for any port setting changes to take effect.

C-10 C-10: C2-DCM Com Port 1 or 2 Setup (Modbus RTU)

Select the Function tab located in the Navigation window and double click Com Port1 Setup or Com Port2 Setup under the Slot0 or Slot1 Data Communication Module, as shown below.

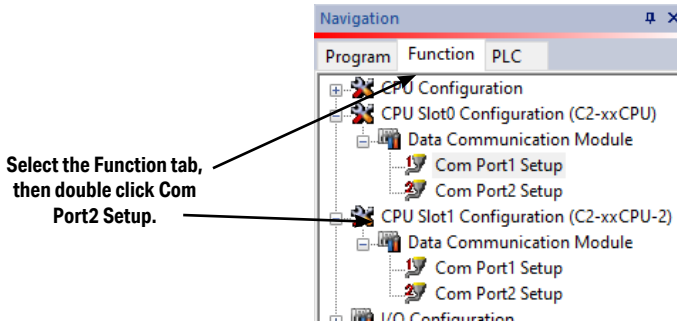

The Com Port Setup Details dialog box will come into view as shown below.

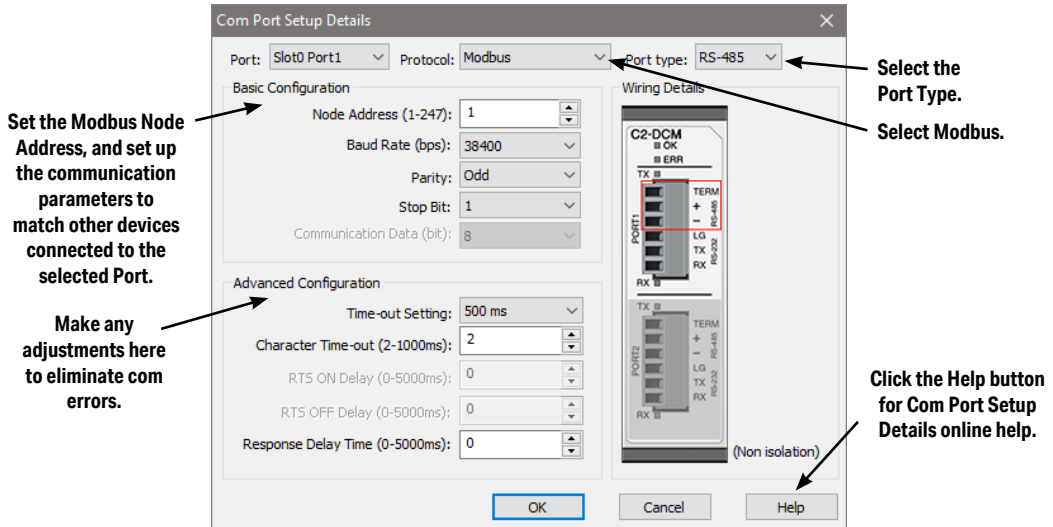

Select your Port type and Protocol. Find the Basic Configuration section in the dialog box and set up the parameters to match other devices in the same network. The dialog box also has a section named Advanced Configuration. You may need to make adjustments to these parameters to overcome communication errors which may occur.



TIP: The communication port settings are saved in the project file. The project must be transferred to the CLICK PLUS PLC in order for any port setting changes to take effect.

P-1 P-1: Modbus Slave (Server) Programming

Ladder Program

To use a CLICK PLUS PLC as a Serial Modbus slave, you don't need any special ladder program. Set up the communication port properly and you just need an End instruction in the ladder program to put the PLC in Run mode.



To use CLICK PLUS PLC as a Modbus Ethernet Client, the Modbus TCP Server must be enabled.

To enable the Modbus TCP Server, select the **Function** tab located in the Navigation window and expand “Com Port 1 Setup” and double click on Modbus TCP as shown below.

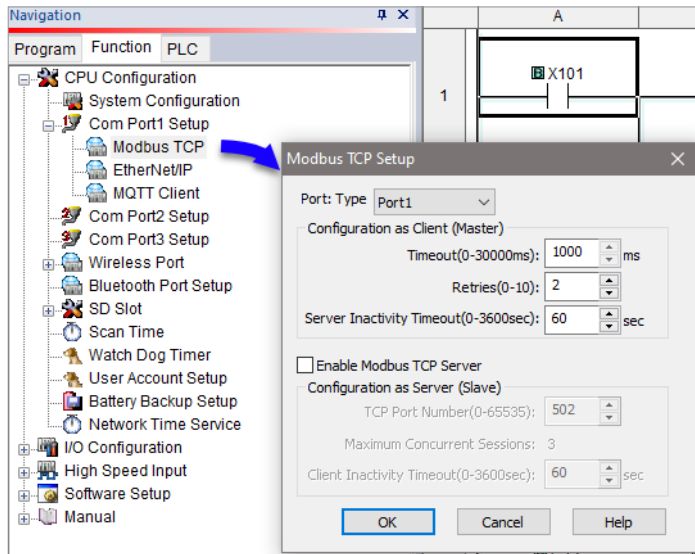

You can add any additional ladder program to let the slave CLICK PLUS PLC control something by itself. For instance, you may want to shut down the outputs on the slave (server) CLICK PLUS PLC should it lose communication with the Modbus master (client).



NOTE: The Modbus master can communicate with the Modbus slave CLICK PLUS PLC without any ladder program. However, output points on the Modbus slave CLICK PLUS PLC cannot be turned on if the PLC is not in the Run mode. Because of this, we recommend having at least one End instruction and to put the PLC in Run mode.

Lost Communication Situation

You may want to detect if there is something happening at the Modbus master side that stops communication with the Modbus slaves. Or, the communication cable might have been disconnected. In this situation, you may want the Modbus slaves to take an action. For instance, you may want to shut down the outputs on the slave CLICK PLUS PLC when the communication with the Modbus master is lost. We offer an easy method to accomplish this.

The CLICK keeps counting how long it has been since each com port received a message from the Modbus master, and enters the time duration in the following system data registers.

System Data Registers		
System Data Register	Nickname	Range
SD41	_Port1_No_Comm_Time	0 - 32767 (sec)
SD51	_Port2_No_Comm_Time	0 - 32767 (sec)
SD61	_Port3_No_Comm_Time	0 - 32767 (sec)
SD214	_WLAN_No_Comm_Time	0 - 32767 (sec)

Each register is reset to zero automatically when the com port receives a message from the Modbus master. Then its value increments by 1 per second until the com port receives another message from the Modbus master. If one of these registers has 60 as its value, it means the com port has not received any message from the Modbus master for 60 seconds. You can use this info to shut down the outputs on the slave CLICK PLUS PLC. Here is an example program.

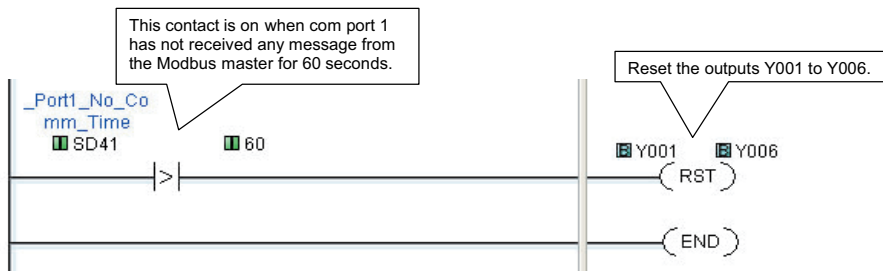

Modbus Addressing

Each of the memory addresses in the CLICK (X1, DS1, etc.) has a unique Modbus address. This means the network master in the Modbus network can access any memory address in the slave CLICK PLUS PLC. The best way to check which Modbus address is assigned to a particular CLICK memory address is to use the CLICK programming software.

Click the Program tab located in the Navigation window and double click Address Picker as shown below.

After the Address Picker window opens, check the option Display MODBUS Address on the right bottom.

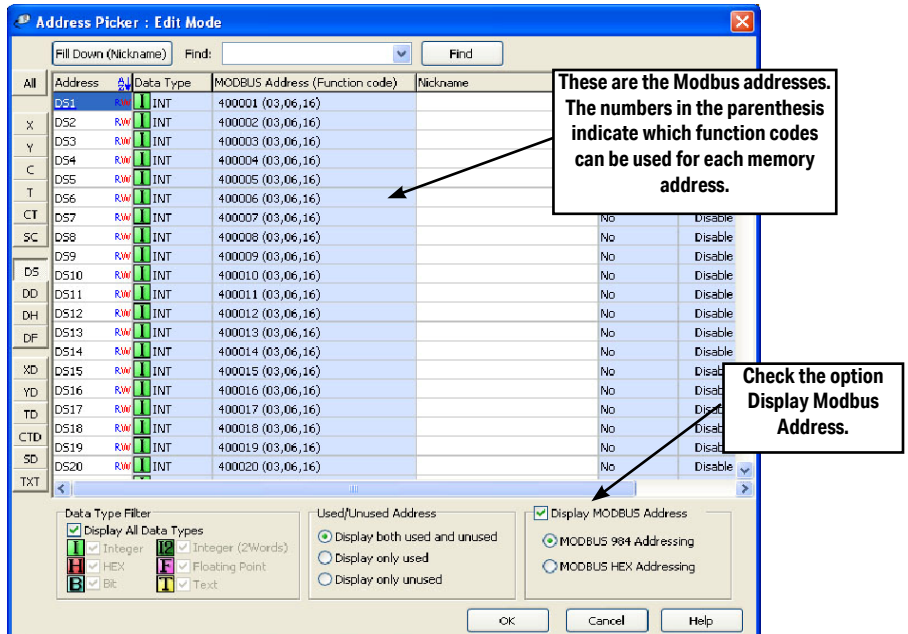
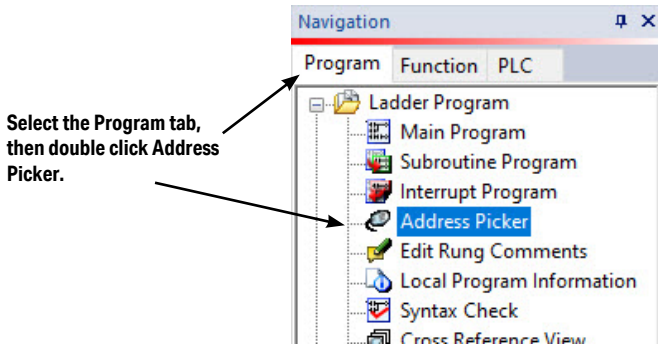

Exception Response (Exception Code)

When the slave CLICK PLUS PLC receives a request from the Modbus master that it cannot respond to, the slave CLICK PLUS PLC sends an exception response to the Modbus master. The CLICK PLUS PLC supports the following Exception Responses.

Exception Response (Exception Code)		
Code	Name	Details of Exception Response
01	Illegal Function	The CLICK PLUS PLC does not support the function code received from the MODBUS master.
02	Illegal Data Address	The MODBUS master tried to access to an invalid address.
03	Illegal Data Value	The data length is zero or exceeds the maximum size.
		The data for Write Single Coil is not FF00h (ON) or 0000h (OFF).
		The PLC mode change request from the MODBUS master is not valid.
04	Slave Device Failure	Password is locked.
		When the PLC mode switch is in STOP position, the MODBUS master requested to switch to RUN mode.
		When the PLC mode switch is in RUN position, the MODBUS master requested to switch to the Firmware Update mode.

P-2 P-2: Modbus Master Programming (Modbus RTU)

Instructions

The CLICK PLUS PLC has two instructions to exchange data with external Modbus devices through the com ports; the Receive and Send instructions.

- Receive instruction: Read data from an external Modbus device.
- Send instruction: Write data to external Modbus device(s).

To use these instructions, double click Receive or Send in the Instruction List window as shown below.

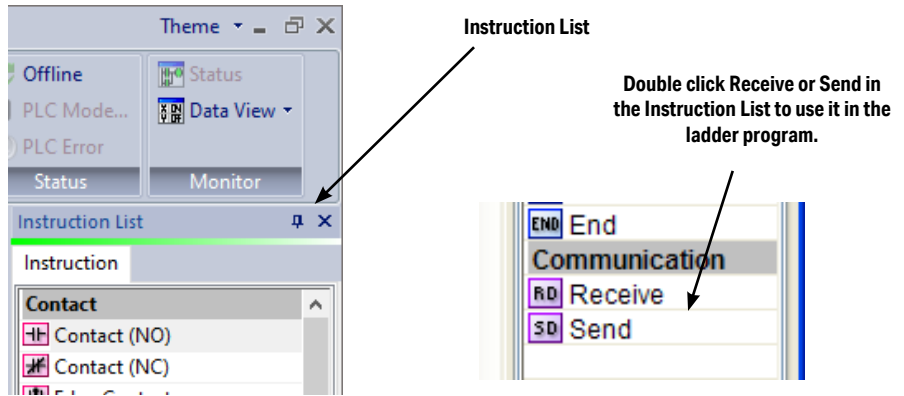

Select the Com Port that you are going to use and confirm the Protocol is MODBUS.

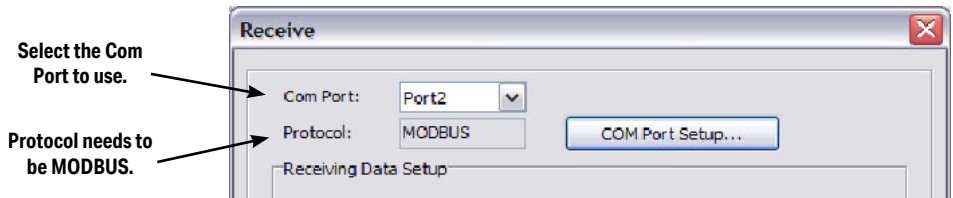

If the Protocol is not MODBUS, click the Com Port Setup button to open the Com Port Setup Details window and change the Protocol to MODBUS. If the Protocol selection is grayed out as shown below, it means the Com Port is used by another Receive and/or Send instruction in the ladder program. You cannot change the Protocol setup until you delete those instructions.



Chapter 4: PLC Communications

When you open the Receive or Send instruction in the Modbus mode, their windows should look like this. For the explanation of each setup parameter, please click the Help button on the bottom right.

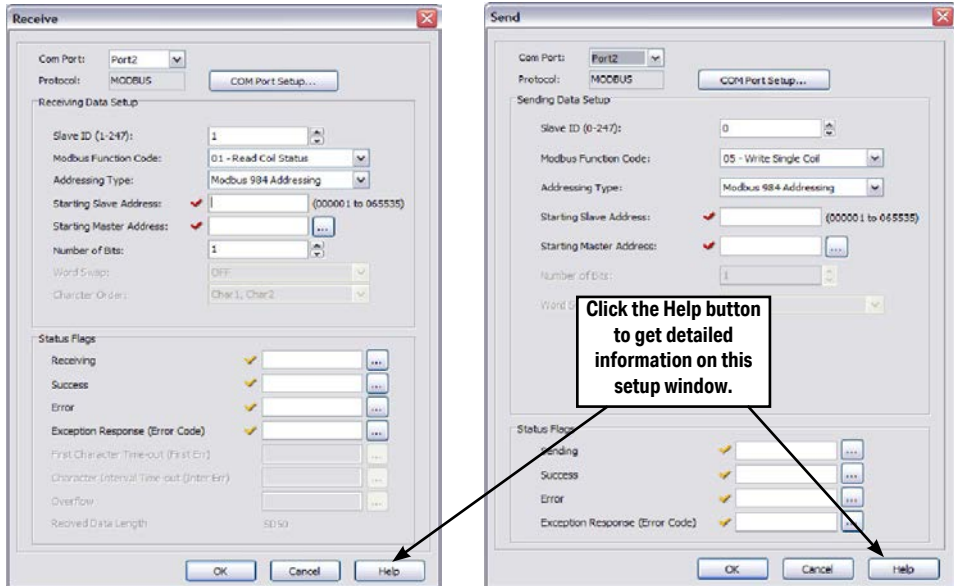

Com Port Status Indicators

The CLICK PLC has the following System Control Relays to indicate the status of the Com Ports. If monitoring these bits in ladder, they should be monitored at a ladder location prior to the Receive or Send instructions for the port.

System Control Relays		
Address	Nickname	Description
SC100	Port_2_Ready_Flag	On when Port 2 is ready.
SC101*	Port_2_Error_Flag	On when Port 2 has a communication error.
SC102	Port_3_Ready_Flag	On when Port 3 is ready.
SC103*	Port_3_Error_Flag	On when Port 3 has a communication error.

* Errors that will cause SC101 or SC103 error flag to turn on:

- Parity Error
- Frame Error
- Time Out
- CRC Error
- Modbus Exception Response

Example Program

The ladder program to use these Receive and Send instructions are easy. You just need one NO (Normally Open) contact instruction to check if the com port is ready to receive or send data.

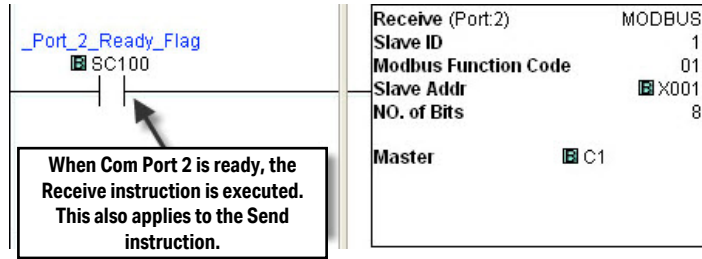

Interlocking

If you are going to use more than one Receive and/or Send instruction with a serial communication port, you need to be sure only one of the instructions is enabled at any point during the operation. The technique to execute more than one Receive and/or Send instructions in order is called 'Interlocking'. When the Interlocking sample program below is executed, the two Receive instructions and two Send instructions are executed one by one.

Example Program: Interlocking with Two Slaves

In this example, Port 3 on the CLICK PLC unit communicates with two MODBUS slaves. The slave IDs (node numbers) are 1 and 2. The CLICK PLC unit executes one Receive instruction and one Send instruction with each MODBUS slave.

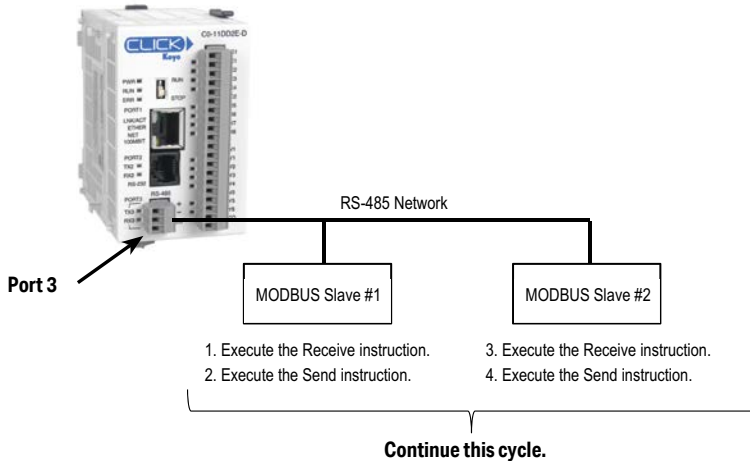

Example Program: Interlocking with Two Slaves (Continued)

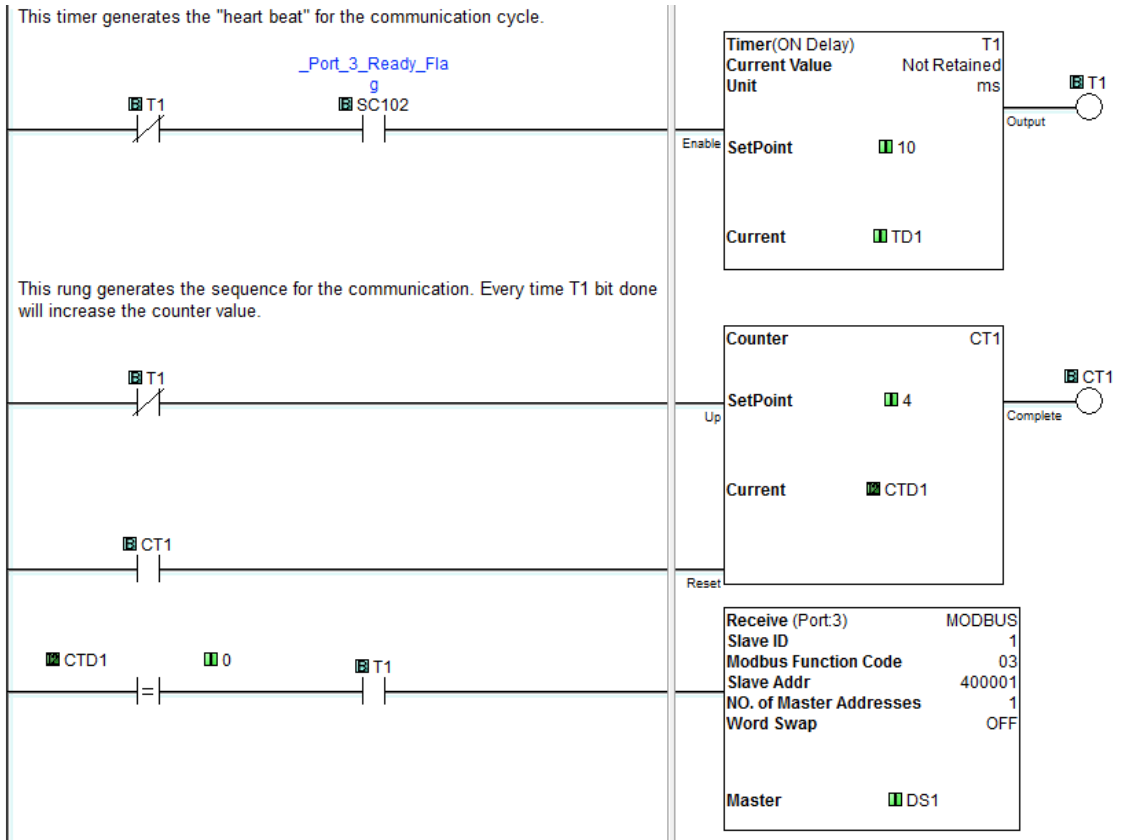

Example Program: Interlocking with Two Slaves (Continued)

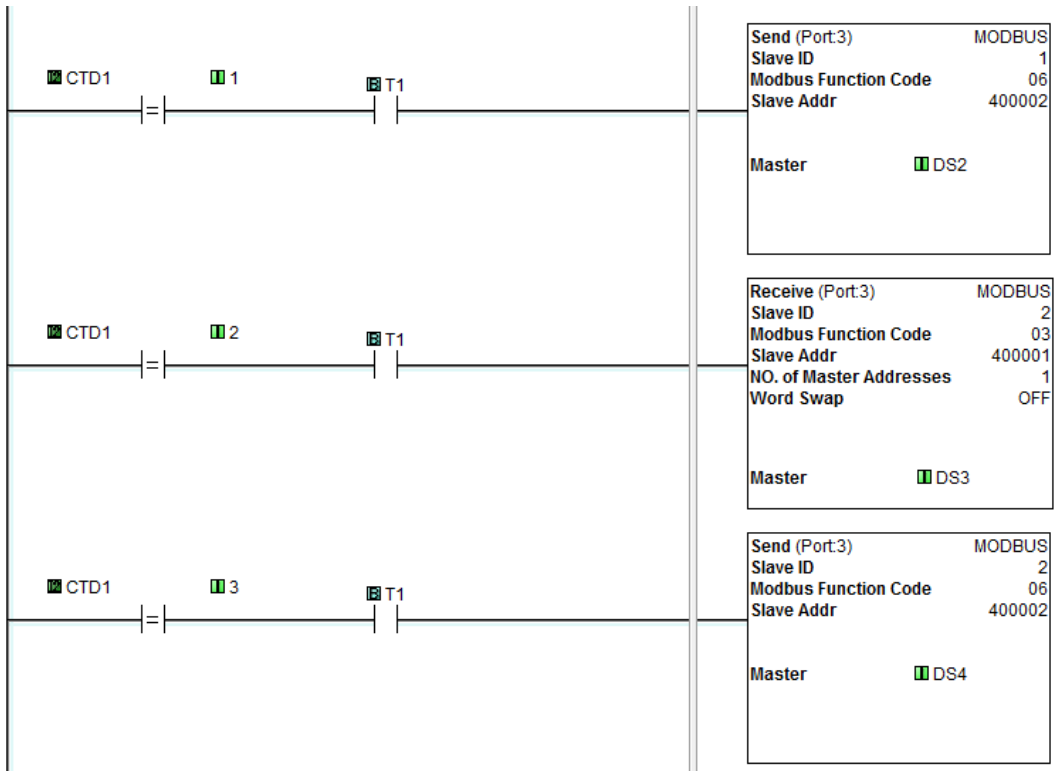

P-3 P-3: Modbus Client (Modbus TCP) Programming

Instructions

The CLICK PLC has two instructions to exchange data with Modbus servers through the Com Port 1; the Receive and Send instructions.

- **Receive** instruction: Read data from external Modbus server.
- **Send** instruction: Write data to external Modbus server(s).

To use these instructions, double click Receive or Send in the Instruction List window as shown below.

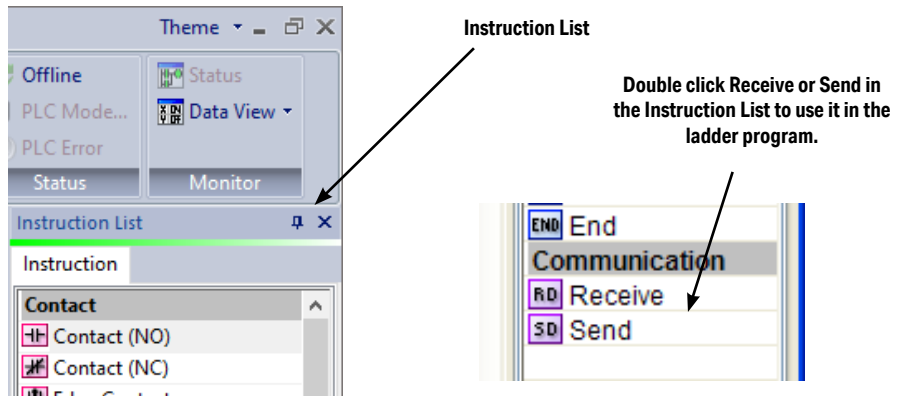

Select Com Port 1 that you are going to use.

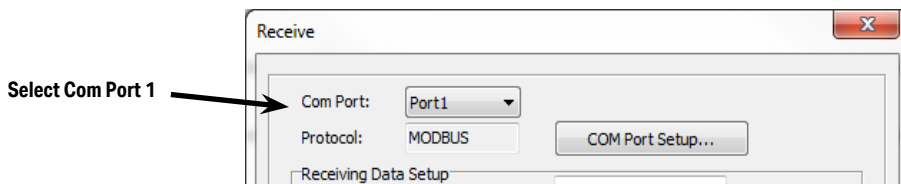

When you open the Receive or Send instruction in the Modbus mode, their windows should look like this. For the explanation of each setup parameter, please click the Help button on the bottom right.

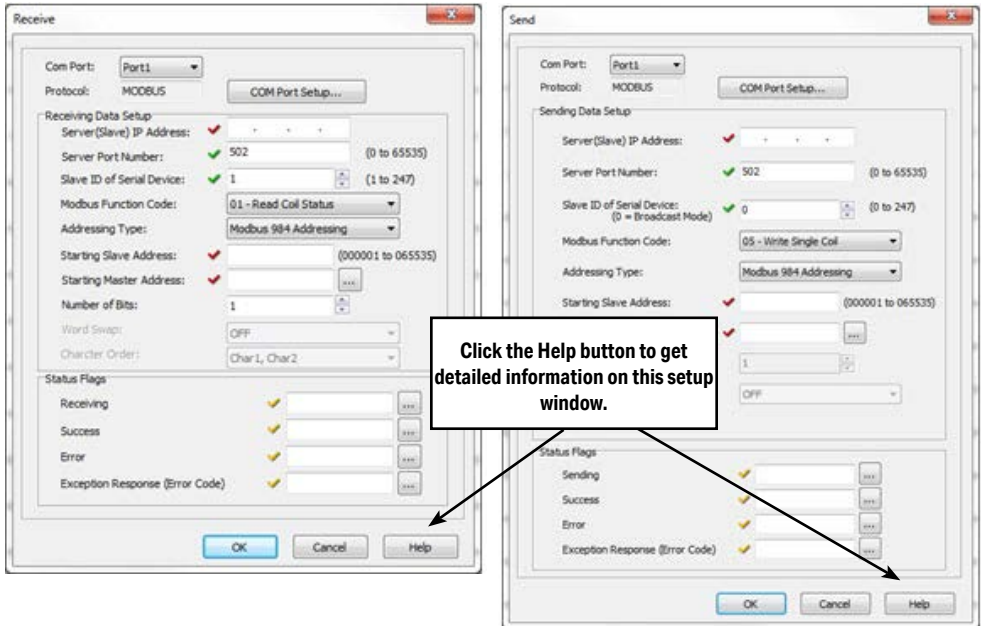

Com Port Status Indicators

The CLICK PLUS PLC has the following System Control Relays to indicate the status of Com Port 1 and the WLAN port.

System Control Relays		
Address	Nickname	Description
SC80	_WLAN_Ready_Flag	ON when WLAN is Ready, does not indicate Busy Status
SC81	_WLAN_Error_Flag	ON when there is a WLAN error. SD213 will contain the error information.
SC82	_WLAN_Connection_Limit	ON when all of WLAN server connections are busy.
SC83	_WLAN_IP_Resolved	ON when WLAN IP Address is assigned
SC84	_WLAN_Connected	ON when WLAN is connected to the access point.
SC86	_WLAN_DHCP_Enabled	ON when WLAN is configured for DHCP.
SC87	_WLAN_DNS_Success	ON when WLAN DNS Lookup was successful.
SC88	_WLAN_DNS_Error	ON when WLAN DNS Lookup was an error.
SC90	_Port_1_Ready_Flag	ON when Port 1 is ready.
SC91	_Port_1_Error_Flag	ON when Port 1 has a communication error.
SC92	_Port_1_Clients_Limit	ON when Port 1 is communicating with 3 clients.
SC93	_Port_1_IP_Resolved	ON when Port 1 obtains an IP address.
SC94	_Port_1_Link_Flag	ON when Port 1 is connected to an Ethernet network.
SC95	_Port_1_100MBIT_Flag	ON when Port 1 is communicating at 100Mbps.

Example Program

The ladder program to use these Receive and Send instructions are easy. You just need one NO (Normally Open) contact instruction to check if the com port is ready to receive or send data.

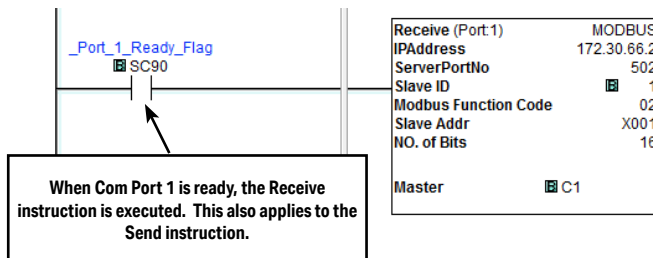

Interlocking

If you are going to use more than one Receive and/or Send instruction with the same server(slave), you need to be sure only one of the instructions is enabled at any point during the operation. The technique to execute more than one Receive and/or Send instructions in order is called 'Interlocking'. When the Interlocking sample program below is executed, one Receive instruction and one Send instruction is executed one-by-one for each server.

Example Program: Interlocking with Two Servers

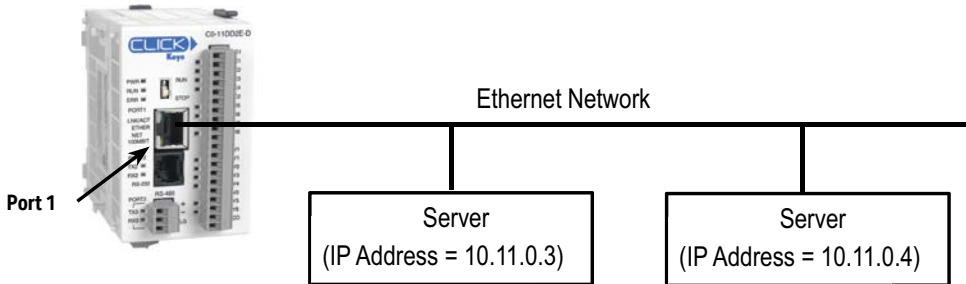

1. Execute the Receive instruction.
2. Execute the Send instruction.

Continue these steps.

1. Execute the Receive instruction.
2. Execute the Send instruction.

Continue these steps.



NOTE: Port 1 can establish the connection with up to 4 servers at the same time.

Chapter 4: PLC Communications

Example Program: Interlocking with a Server (Continued)

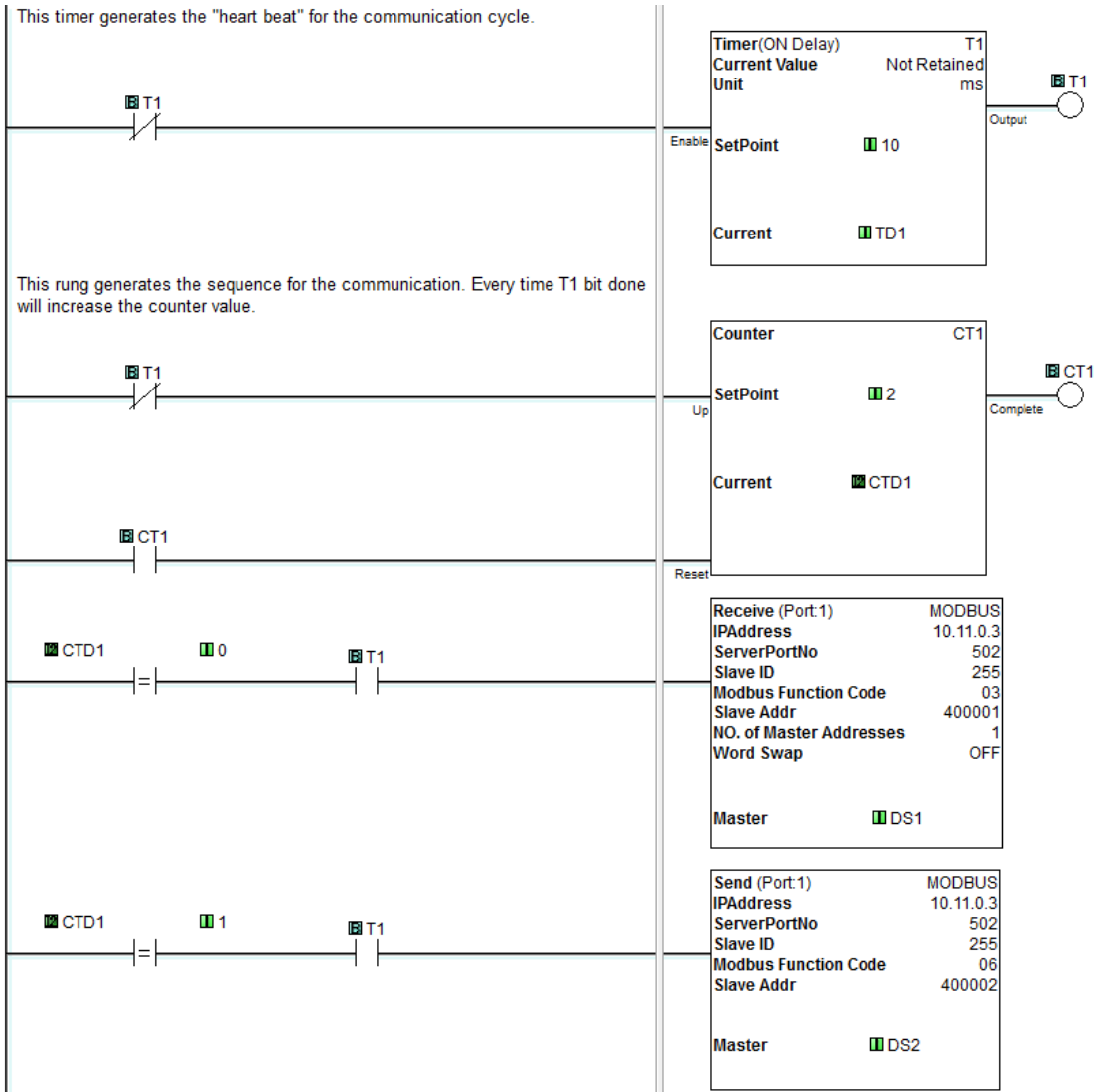

Example Program: Interlocking with a Server (Continued)

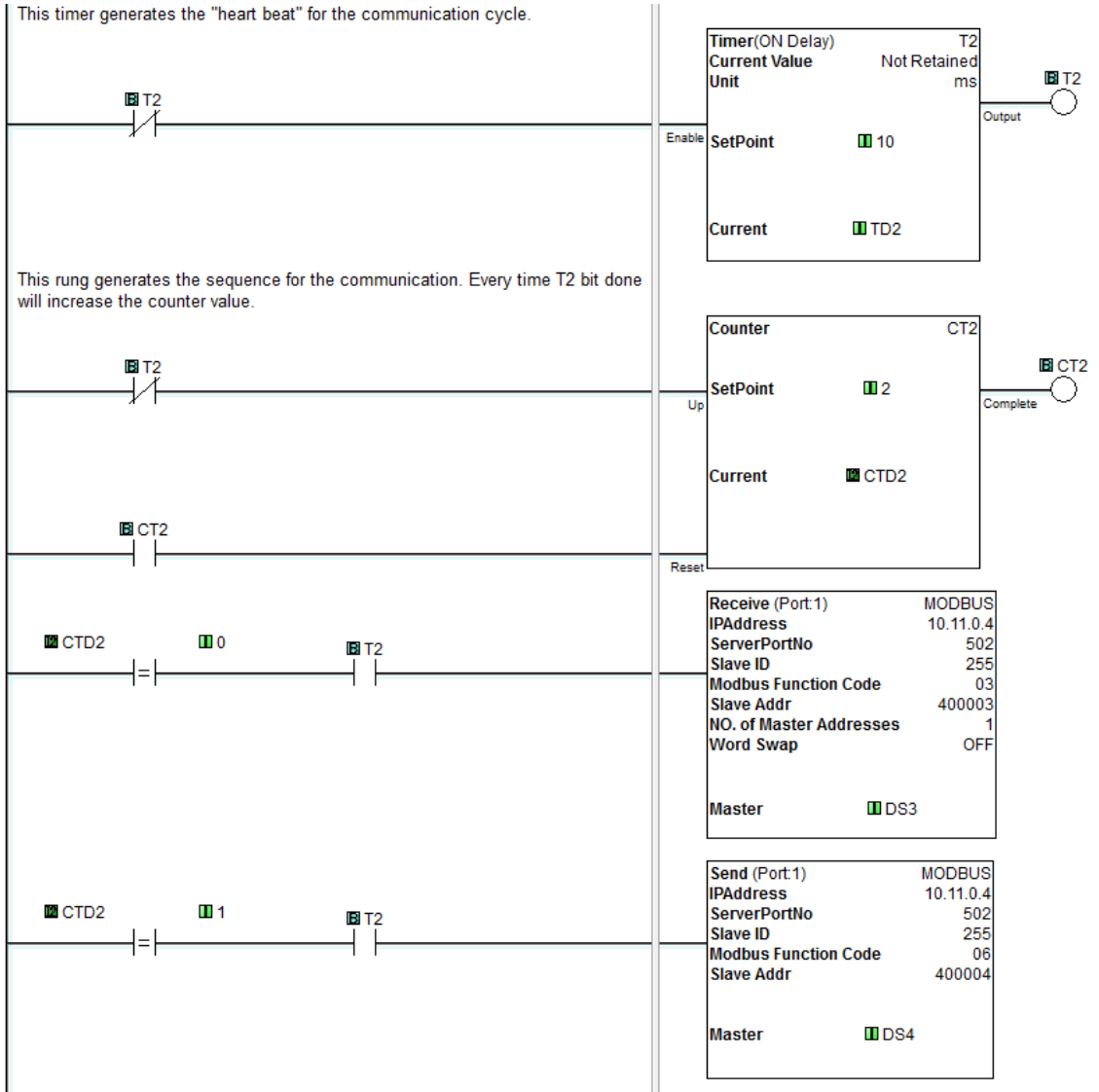

P-4 P-4: ASCII Receive Programming

Instruction

The Receive instruction allows the CLICK PLC to read ASCII message from an external device. To use this instruction, double click Receive in the Instruction List window as shown below.

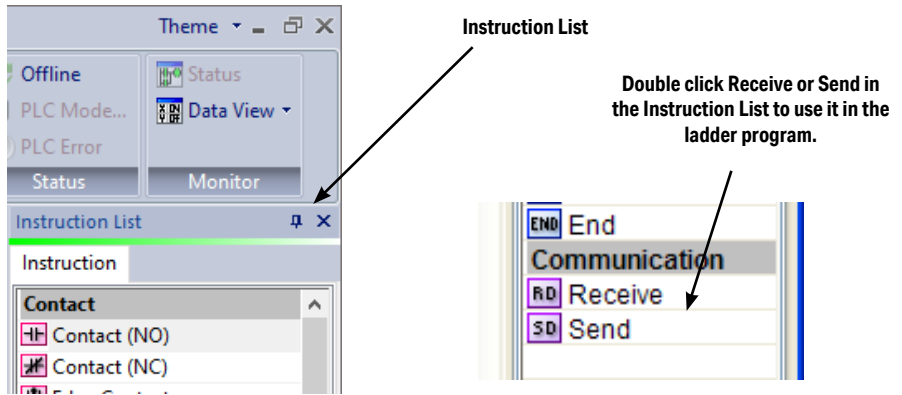

Select the Com Port that you are going to use and confirm the Protocol is ASCII.

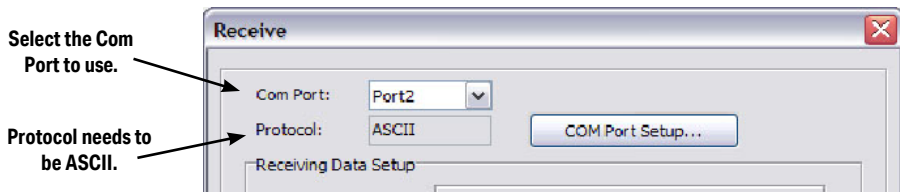

If the Protocol is not ASCII, click the Com Port Setup button to open the Com Port Setup Details window and change the Protocol to ASCII. If the Protocol selection is grayed out as shown below, it means the Com Port is used by another Receive and/or Send instruction in the ladder program. You cannot change the Protocol setup until you delete those instructions.



When you open the Receive instruction in the ASCII mode, the window should look like this. For the explanation of each setup parameter, please click the Help button on the bottom right

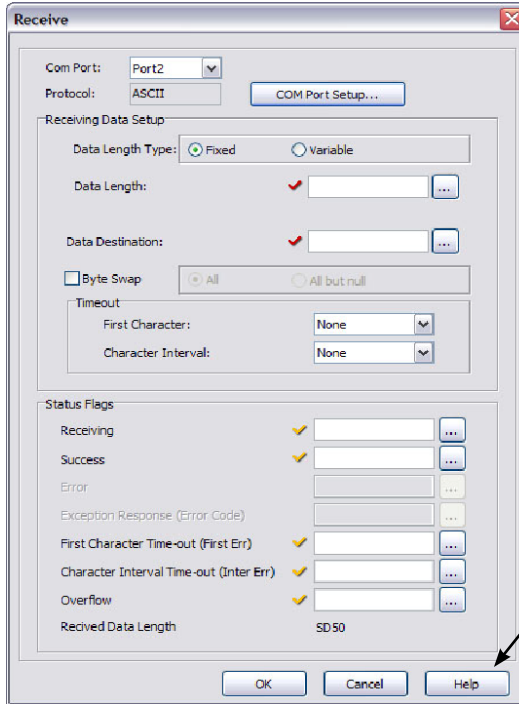

Click the Help button to get the detailed information of this setup window.

Example 1: Read ASCII message from a barcode reader.

With the following example program, when C1 is ON, the Receive instruction is activated and Com Port 2 waits for an ASCII message from the barcode reader. When Com Port 2 receives an ASCII message and it includes the termination character (CR = Carriage Return in this example), C2 is turned on and the received ASCII message is copied to TXT1 address.

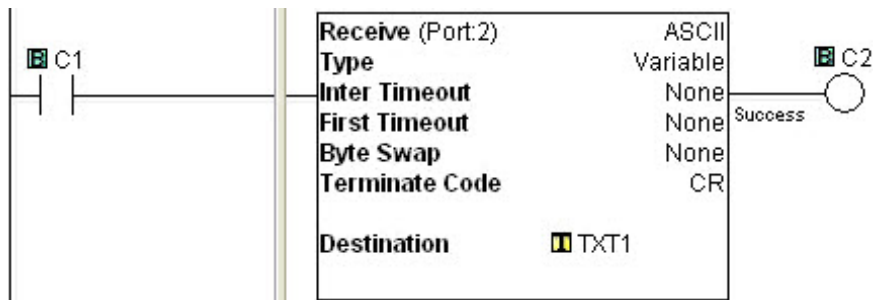

Example 2: Retrieve numerical data from the received ASCII message.

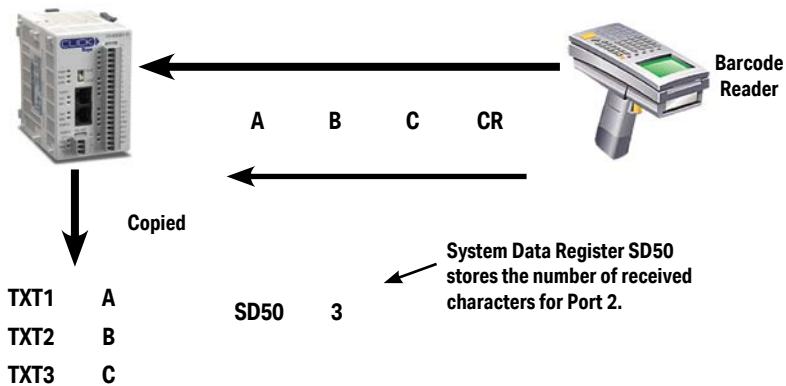

When numerical data is included in the received ASCII message, you may want to retrieve the numerical data and copy into a data register. The Copy instruction can be used for this purpose.

In this example, received ASCII message is stored in TXT1 to TXT6. This ASCII message includes numerical data '1.23' as ASCII characters from TXT3 to TXT6. The Copy instruction converts those ASCII characters into the equivalent numerical data and copies into data register DF1.

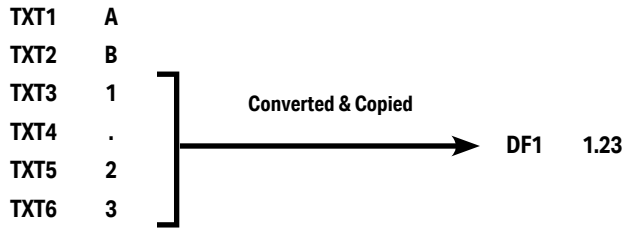
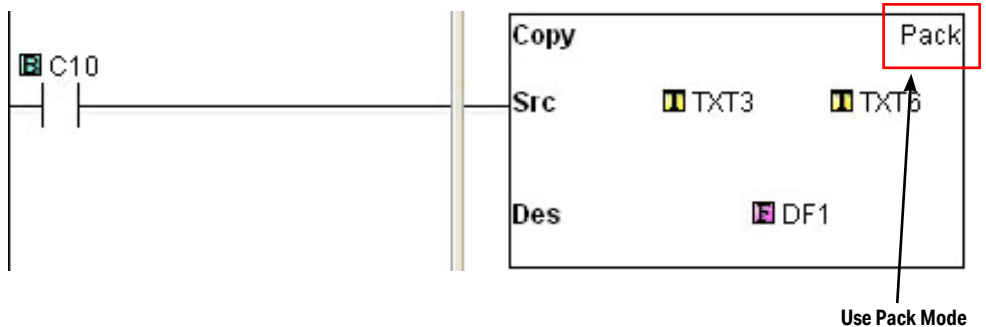

P-5 P-5: ASCII Send Programming

Instruction

The Send instruction allows the CLICK PLC to send ASCII messages to an external device. To use this instruction, double click Send in the Instruction List window as shown below.

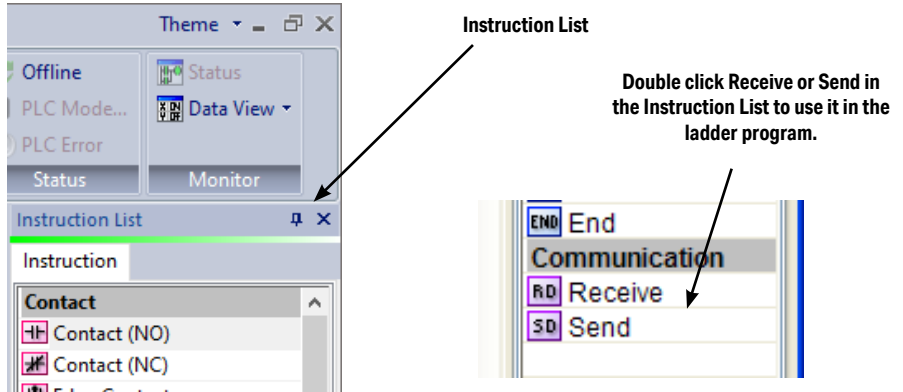

Select the Com Port that you are going to use and confirm the Protocol is ASCII.

If the Protocol is not ASCII, click the Com Port Setup button to open the Com Port Setup

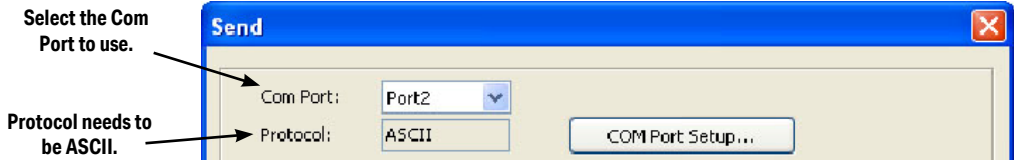

Details window and change the Protocol to ASCII. If the Protocol selection is grayed out as shown below, it means the Com Port is used by another Receive and/or Send instruction the ladder program. You cannot change the Protocol setup until you delete those instructions.



Chapter 4: PLC Communications

When you open the Send instruction in the ASCII mode, the window should look like this. For the explanation of each setup parameter, please click the Help button on the bottom right.

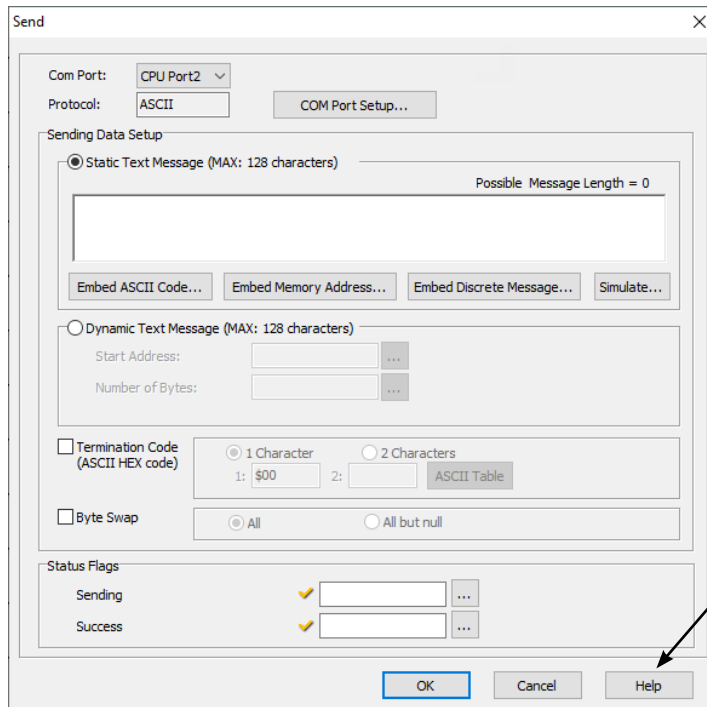

Click the Help button to get detailed information on this setup window.

Example: Send ASCII message to a serial printer.

With the following example program, when status of C1 changes from OFF to ON, the Send instruction sends ASCII message 'ABC' and the termination character (CR = Carriage Return in this example). C2 is turned on when sending the ASCII message is completed.

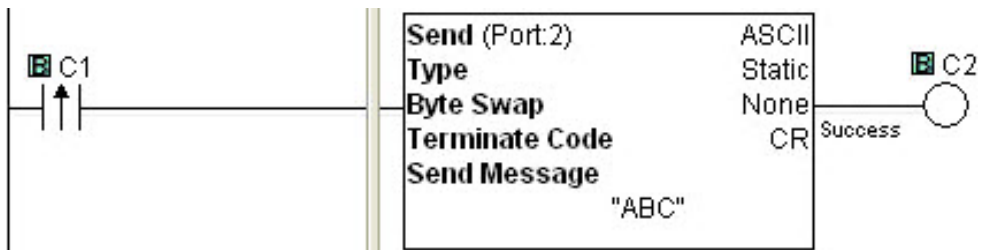

INTELLIGENT MODULES



In This Chapter...

CLICK PLUS Intelligent Modules	5-2
C2-DCM Communication Module.....	5-2
C2-NRED Node-RED Module	5-3
C2-OPCUA OPC UA Server Module.....	5-28

CLICK PLUS Intelligent Modules

The CLICK PLUS Intelligent Modules are a series of Option Slot modules that contain onboard processing. These modules allow us to implement computationally intensive features without affecting with the performance of the ladder logic program running on the CLICK CPU.

Each intelligent module is self-contained, with dedicated processor, RAM and storage. The modules communicate with the CLICK CPU on its internal bus.

C2-DCM Communication Module

The C2-DCM module adds two more serial ports to a CLICK PLUS PLC. Each port can be configured as either an RS-232 or RS-485 connection, and can communicate with either Modbus RTU or ASCII protocols.

The C2-DCM ports are configured in the CLICK Programming software, and offer the same options as the built-in serial ports.

C2-NRED Node-RED Module

Introduction

What is Node-RED

Node-RED is an Open Source “Low-Code” programming tool for wiring together hardware devices, APIs and online services in new and interesting ways.

It provides a browser-based editor that makes it easy to wire together flows using the wide range of nodes in the palette that can be deployed to its runtime in a single-click.

What is C2-NRED

The C2-NRED is a CLICK PLUS PLC Slot Module that enables a fully autonomous processor to run Node-RED software and share memory with a CLICK PLUS PLC. This direct integration provides the following benefits:

- An Industrial package with DIN Rail mounting, power and communications shared with the CLICK PLUS PLC.
- Project Backup and Set up tools.
- A shared Backplane – enabling the C2-NRED module to directly read the CLICK PLUS memory registers. No more configuring communications with your PLC.
- Independent Processors, the CLICK PLUS PLC and the C2-NRED modules each have their own processors, so while they share memory, the application processing times on the CLICK PLUS will not be impacted by heavy data processing or communications on the C2-NRED module.

System Requirements

- **Hardware:** The C2-NRED module is compatible with slot 0 or slot 1 of any CLICK PLUS PLC with one or two option slots.
- **Software:** Requires CLICK Programming software version 3.70 or above. Compatible with Google Chrome v128+ or Microsoft Edge v128+
- **Network:** USB2.1 compatible port on Windows PC or 10 Mbps or faster Ethernet TCP/IP network

Recommended CLICK Node-RED BOM

Qty	Part Number	Notes
1	C2-01CPU or C2-01CPU-2	You'll want an ethernet port but there is limited need for the WiFi option since the C2-NRED module requires a wired connection.
1	C0-01AC	CLICK 24VDC power supply.
1	C2-NRED	The Node-Red module.
1	D0-MC-BAT	Battery to extend the memory storage time from 1 hour to a typical 3 years.
1	SE3-SW5U	Unmanaged 5 port switch.
2	C5E-STPBK-S3	3ft cat5e cables for the CLICK and C2-NRED modules.
1	C5E-STPBK-S10	10ft cat5e cable to connect to your PC.



NOTE: Don't forget I/O modules for your application!

These part numbers are a representative example. Be sure to review the cable lengths, quantities, type of ethernet switch required and so forth.

Installation



NOTE: If your CLICK PLUS PLC Firmware is below version 3.70, update the firmware in the PLC prior to installing the C2-NRED module.

Follow the instructions in the “Install the CLICK Programming Software” section of Chapter 1 to get the latest version of the CLICK Programming software installed on your PC. Refer to the CLICK PLUS application help files for more information:

[CLICK Help Version 3.70 - Introduction \(automationdirect.com\)](http://www.automationdirect.com)

After powering on and connecting to the CLICK PLUS PLC from the CLICK Programming Software, you must update the firmware to get both the CLICK PLUS PLC and the C2-NRED module up to the release version of firmware.

It is strongly advised to update the CLICK PLUS PLC firmware BEFORE installing the C2-NRED Module.

Follow these steps:

1. Ensure you have 24VDC wired to the CLICK PLUS PLC. (Do not use the USB low power mode.)
2. BEFORE you install the C2-NRED module, connect to the CLICK PLUS PLC and update the firmware.
3. Power off the CPU.
4. Install the C2-NRED module, following the hardware installation instructions in the “Installing Option Slot Modules” section of Chapter 3.
5. Restore power.
6. Update the firmware again—this time it will update the C2-NRED firmware. This process can take up to 20 minutes.

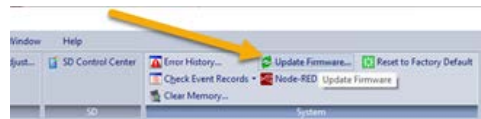

Project Configuration

Once the firmware is up to date, you must enable the C2-NRED in order to begin. See the [C2-NRED Module Configuration](#) topic in the online help for details on configuring the module.

Time (RTC)

The C2-NRED module shares a clock with your CLICK PLUS PLC. Be sure to update the time in the PLC. Click the PLC tab at the top of the CLICK programming software. Then click “Calendar/Clock Adjust”. If the time is wrong, it may impact your ability to download 3rd party modules into the Node-RED environment. Those modules are signed and if your clock is not set, you will get CERT_NOT_YET_VALID errors.

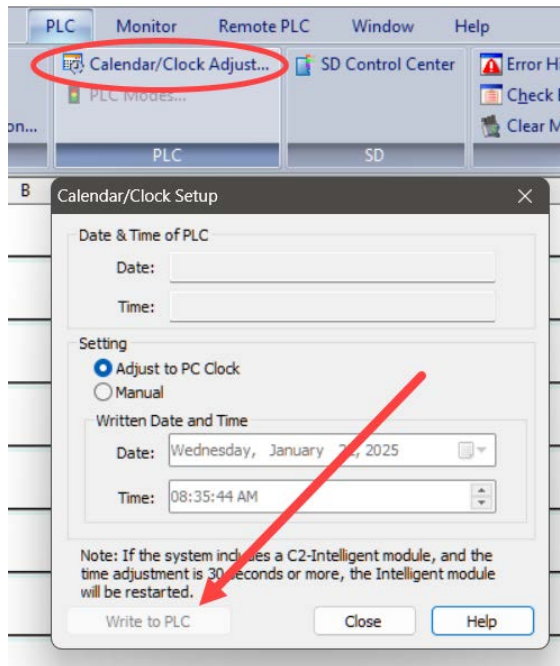

Communication

Once you have enabled Node-RED, you are able to connect to the C2-NRED module. There are 3 ways to connect:

USB — Using a USB Cable, plug into the C2-NRED module. This will enable the ability to begin programming and configuring the module with the following limitations:

- Limited ability to install add on Node-RED Modules
- No ability to connect to the network using ANY Network Nodes

Those communication abilities require a direct connection to the network, not a bridged connection through your PC.

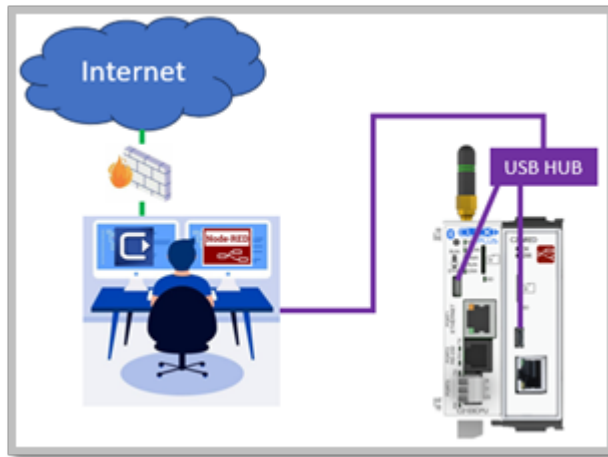

USB and Ethernet — Connect the C2-NRED module to your PC using the USB Cable and connect the C2-NRED to your network using an Ethernet cable. This will allow you to program the C2-NRED using USB, but the web server will access the network over Ethernet.

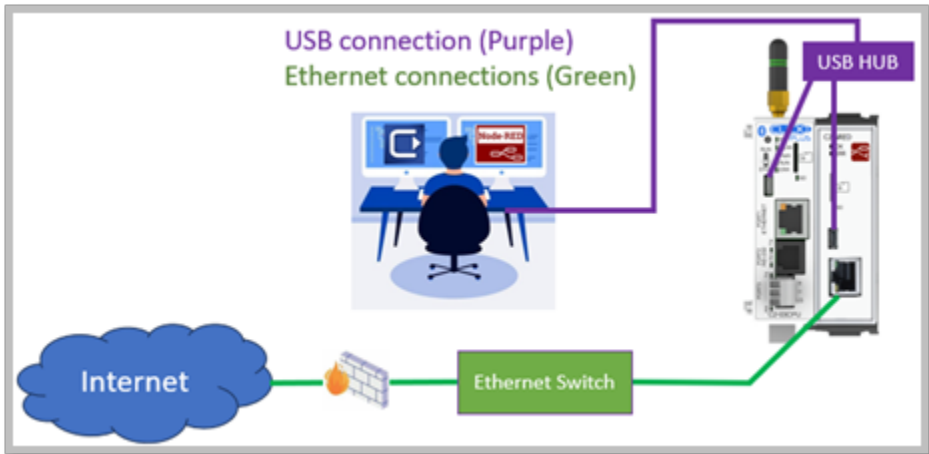

OR

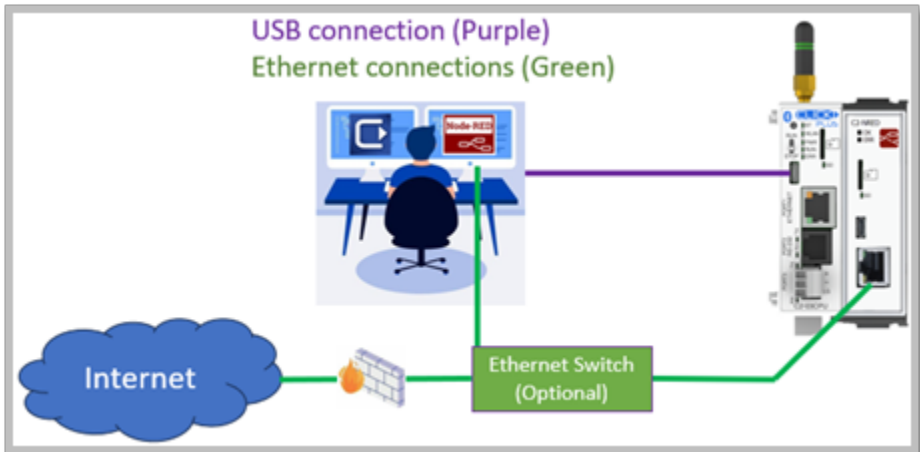

Ethernet Only* — Connect your PC, and each Ethernet enabled module to a switch. All modules can be accessed over the same network and all will have access to HTTP services. If you have multiple network adapters on your PC (Wi-Fi and Wired, or multiple wired), you will not be able to connect one adapter to an external network (Internet) and the second adapter to the C2-NRED module. Node-RED will not communicate across bridged adapters or shared connections.

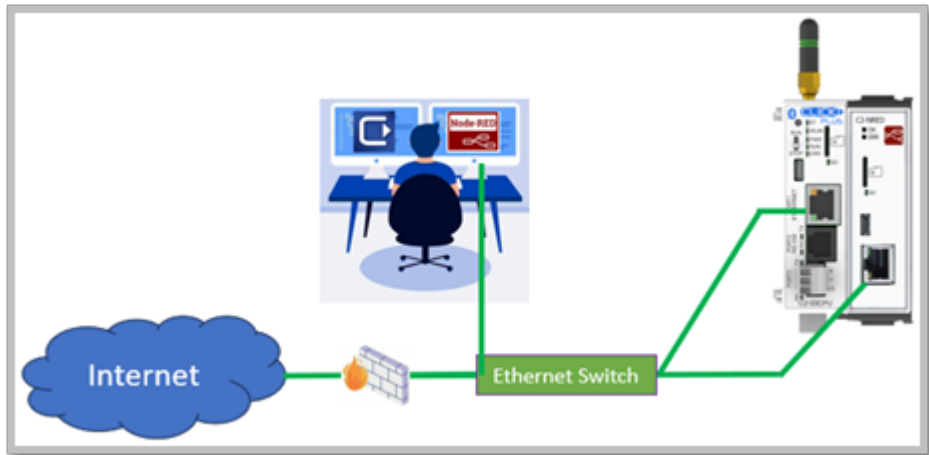

*This is the recommended approach due to its simplicity and speed.

Updating Firmware

After installing your C2-NRED module and ensuring you have stable communications, ensure you are using the most up to date firmware. You can check by using the Update Firmware option in the CLICK Programming software.



This will open a window which will show the current firmware version installed in both the PLC and the C2-NRED module. It will give you the option to update the firmware for both devices.



NOTE: *Upgrading the firmware in the C2-NRED module will reset the unit to factory settings. It will erase all third party add-ons as well as your application.*

Follow these steps exactly when upgrading firmware. There is no “undo” option.

1. Before you begin the firmware upgrade process:
 - a. Make a backup of your CLICK Program and settings (.CKP file).
 - b. Open Node-RED.
 - c. Open the Manage Pallet option under the menu.
 - d. Record the EXACT Names of each of the Nodes you have imported for your project.
 - e. Export your projects (Menu – Export).
 - f. The C2-NRED module must have internet access to reinstall any imported nodes, or you should ensure you have the source .tgz files for any third party modules. (See the “Getting Your Project Ready for Production” section later in this chapter.)

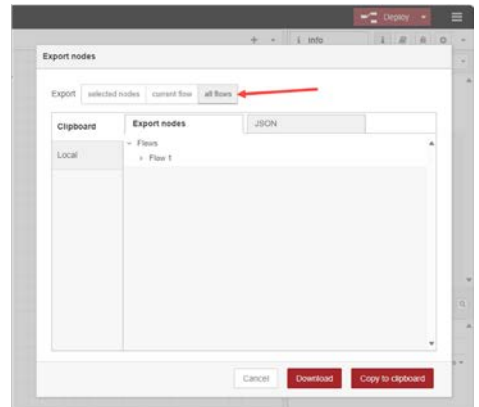
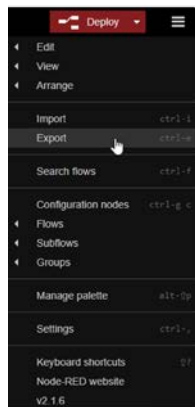

2. Install the latest CLICK PLC Software (Version 3.70 or later).
3. Ensure the PLC is in STOP Mode and has an external 24v power connection (not just power from the USB Connection)
4. Perform a normal firmware update of the CLICK PLUS PLC (to “Ver3.70” or later), and C2-NRED (to “1.0.0.100” or later)
Note: If updating from Version 3.60 or previous, two updates are required. First update the CLICK PLUS PLC, then detect C2-NRED and update again.
5. You may have to disconnect and reconnect to reset your IP address. The firmware update will reset IP addresses to default.
6. Transfer your project file to the CLICK PLUS PLC. If you had previously connected to the C2-NRED, those settings will be rebuilt when you transfer the project file.
7. Make sure your C2-NRED Project Setup has “Enable Node-RED” checked. (Setup Ribbon, Slot0/1 Setting, Node-RED)
8. Enable RUN Mode
9. Data View SD302-SD305 should show “1.0.0.100” or later (SD402-SD405 for Slot1)
10. Connect Web browser to the C2-NRED (USB or Ethernet)
11. Node-RED Version should be “v3.0.2”

Launch Node-RED

When you are ready to launch Node-RED, click the Node-Red Open Node-RED button on the “PLC” Ribbon:



This will open your default web Browser to the IP and port of the C2-NRED module. If you are using a USB connection to the C2-NRED programming port, it may take up to 90 seconds to initialize the USB driver the first time it is opened. Please be patient.

Programming

For those who have written Ladder Logic, the Graphical Programming Language (GPL) and scripting in Node-RED will seem unfamiliar. Conversely for those familiar with scripting languages like JavaScript, Ladder Logic in a CLICK PLUS PLC may feel arcane. All three languages are good and have their strengths, but the marriage of all three in the CLICK C2-NRED module will enable truly new approaches to both industrial control and maker space/commercial applications.

Let's hit a few definitions to ensure programmers understand these technologies.

Ladder Logic

Ladder Logic was developed in the 1970s as a GPL designed to look and operate like standard electrical drawings. The intent was to enable electricians with no programming experience to be able to read and write industrial control applications. The logic flows left to right and top to bottom and can be best understood by the water analogy—if water can flow through the circuit, it will. Take for example this simple latching circuit:

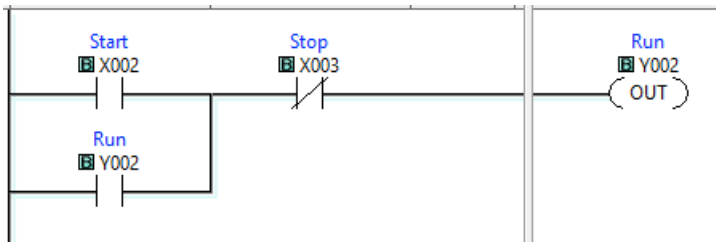

The vertical line on the left is called the power rail. The horizontal row is called a rung (like a rung in a ladder). If you picture water flow down the power rail, it will try to cross the rung. If X002 is an input from a momentary pushbutton, then when the button is pressed, that contact will close and the water will be able to cross that gap. At the same time, the Stop contact (X003) is normally closed, so water can cross it until that button is pressed. Once water hits the “Run” output coil (Y002), the circuit activates. When the coil is activated, the Y002 contact closes indicating it is on and the user no longer needs to hold down the button connected to X002; the circuit holds itself on, or the circuit is latched. An electrical drawing may show a symbol for a button instead of the contact, but otherwise it is the same.

Scripting languages

Scripting is a subset of programming where the program is read by the computer one line at a time. The alternative is a “compiled” application where the computer processes and optimizes the entire application ahead of time, then can run it extremely fast. Scripting languages like JavaScript and Python run slower than compiled, but they are easier to write and debug. The same logic from the example above would look like this:

```
If (X002 or Y002) and (not X003) then {  
  Set Y002;  
}
```

When you look at a rung, ladder executes these “if then” logic sets extremely quickly. Ladder is very good at highspeed real time logic while iterative and sequential processes are sometimes easier to implement using scripting languages.

Flow editor

Node-RED introduces a 3rd type of programming. Like Ladder, it’s a GPL, called a Flow editor. It works like a flow chart where each node performs a function. It can be a simple function like checking a data value, or more advanced like calling a web server to get a block of information. Under the covers, Node-RED builds a JavaScript application. It can even embed function blocks that are JavaScript subroutines.

Here is an example:

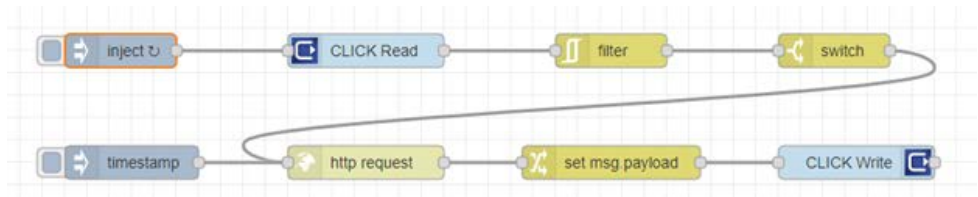

This flow will look for a start bit in the CLICK PLUS PLC (CLICK Read). When it turns “ON”, the C2-NRED will call a web site to get the weather forecast for the next week. That forecast has much more information than we need, so the “set msg.payload” node strips out only the predicted temps for the next 12 hours and writes those back to the PLC with the “CLICK Write” node.

All of this comes together because while ladder’s non-sequential nature makes it great for real time control, it’s harder to write programs for handling synchronous functions with long delays. Without waiting on a signal from the CLICK PLUS to check the weather, this flow could be shrunk to just 4 blocks.

Resources

JavaScript — There are thousands of websites and resources to help write JavaScript. One of the best is ChatGPT. Simply describe what you want the function to do. You'll have to test it and maybe clean it up, but it's surprisingly good at writing working code. These additional reference tools will provide a great start and, in most cases, provide all the information you need.

<https://www.w3schools.com/js/> — W3Schools is an amazing reference library with code examples and tools to test your scripts. You can Google whatever logic you want, add "w3schools" to the search and you'll find easy to follow examples.

<https://devguru.com/content/technologies/javascript/index.html> — DevGuru is more like a reference manual. It will list every command and includes useful examples for each command.

<https://jsonata.org/> — JSONata is a great tool for accessing more complex data in JavaScript. Node-RED uses this tool to help pass useful data from node to node.

Node-RED — the Node-red.org web site is a great place to look for prebuilt libraries, and a rich user community that will help you get started writing amazing Flows.

We recommend watching this YouTube playlist: [Node-RED Essentials 100](#). The videos are done by the developers of node-red. They're nice and short and to the point. You will understand a whole lot in about 1 hour. A small investment for a lot of gain.

Ladder — Automation Direct has tutorials on Ladder Logic and as always, we provide free software to help you test and get comfortable with writing Ladder Logic.

<https://library.automationdirect.com/understanding-ladder-logic/>

Data Structures

The first step to writing a program in any of these languages is understanding how they store and share data.

PLC – PLC data structures are simple data types. Each variable is a number with a prefix that specifies the datatype. You can read more in the [CLICK user guide](#).

Memory Address	Type	Range	Data Type	DataRange
X	Inputs	X001-X816	Bit	0 or 1
Y	Outputs	Y001-Y816	Bit	0 or 1
C	Internal Control Relay	C1-C2000	Bit	0 or 1
T	Timers	T1-T500	Bit	0 or 1
TD	Timer Current Value	TD1-TD500	Single word integer	-32,768 to 32,767
CT	Counters	CT1-CT250	Bit	0 or 1
CTD	Current Counter Value	CTD1-CTD250	Double word integer	-2,147,483,648 to 2,147,483,647
SC	System Control Relay	SC1-SC1000	Bit	0 or 1
DS	Small Integer	DS1-DS4500	Single word integer	-32,768 to 32,767
DD	Large Integer	DD1-DD1000	Double word integer	-2,147,483,648 to 2,147,483,647
DH	Data	DH1-DH500	Hex	0000h to FFFFh
DF	Floating point Number	DF1-DF500	Floating point	-3.4028235e38 to 3.4028235e38
XD	Input Register		Hex	0000h to FFFFh
YD	Output Register		Hex	0000h to FFFFh
SD	System Data Register	SD1-SD1000	Single word integer	-32,768 to 32,767
TXT	Text Data Register	TXT1-TXT1000	ASCII (7-bit)	Single ASCII Character

JavaScript/Node-RED – Since Node-RED is built on JavaScript, it uses the same data types as JavaScript. Variables can be the following:

Variable Type	Range
Boolean	0 or 1, True or False
Number	Any integer or floating point up to 15 digits
BigInt	Over 15 digits - Rarely used
String	An array of characters - Text
Object	A list of key: value pairs
Array	A list of any variable
Date	A date/time value

**Note JavaScript datatypes are defined at runtime by the interpreter. They are not declared by the programmer. Any variable can change types on the fly just by assigning a new value.

Arrays and Objects are the most interesting variable types since they hold other variables.

An Array is a simple list bound by square brackets []. For example, vehicle = [“cars”, “trucks”, “boats”]

The name of the array is vehicle, it contains those 3 values. You can address it by using vehicle[1] and the result is “trucks”. Notice, the first element is vehicle[0] and the last is vehicle[2].

An Object is like an array, but instead of a simple list, you can name each of the values in the list. These are known as Key: Value pairs. Objects are bound by curly brackets {}.

For example, `person = {firstName:"John", lastName:"Doe", age:43}`

The name of the object is `person`. You can address it in two ways.

1. Key.Value e.g. `person.firstName` will return "John". This is called dot notation.
2. Key["Value"] e.g. `person["firstName"]` will also return John. This is called bracket notation.

Dot notation is more concise, but you're not allowed to use spaces in the Key. Bracket notation is useful if you want your keys to contain spaces. `Person.first Name` isn't a valid variable because of the space between `first` and `Name`, but `person["first Name"]` is fine.

When these data structures are combined, you get a structure called JSON – JavaScript Object Notation. This is where you have an object that contains a list of arrays or other objects. For example:

```
Company = {
  "employees":[
    {"firstName":"John", "lastName":"Doe"},
    {"firstName":"Anna", "lastName":"Smith"},
    {"firstName":"Peter", "lastName":"Jones"}
  ],
  "cars":[
    "Audi",
    "Volvo",
    "Ford"
  ]
}
```

This object "Company" contains two arrays, `employees` and `cars`. You can address them using dot or bracket notation. `Company.employees[1].firstName` returns "Anna" or `Company.cars[0]` returns "Audi". You can use the JSONata tool set (see reference tools earlier in this chapter) to help practice locating information in large JSON data sets.

As you start working with more data, JSON objects can get very large and complex. In fact some databases known as NoSQL databases use JSON objects to store massive datasets with billions of records. Many modern web sites make Application Programming Interfaces (APIs) available to access data sets. JSON is a standard format that allows web applications to share data using what are called RESTful web services. Amazon provides a detailed explanation here: [What is RESTful API? - RESTful API Explained - AWS \(amazon.com\)](https://aws.amazon.com/rest-api/). This is the real power of Node-Red when used with CLICK. It brings together real time control on the factory floor with business and operations data provided by modern web applications, then provides the tools to use both efficiently.

Node-Red also supports four types of variables:

1. The msg object – passes data between the nodes.
2. The context object -stores data for a node.
3. The Flow object – stores data for a flow.
4. The global object -stores data for the canvas.

Using these object inside a function node looks like this:

```
name =context.get("name"); //to retrieve a variable
context.set("name",name); // to store a variable
```

Here is a full example script that create a counter which tells you how many times this specific node has been called:

```
var local=context.get('data') || {}; //get the value in data and assign it to local
if (local.count===undefined)//test exists
{
    local.count=0;
}
local.count +=1;
msg.payload="F2 "+msg.payload+" "+local.count;
context.set('data',local);
return msg;
```

The Flow object works the exact same way, but if you use that script in multiple functions, it would count how many times any of those function nodes have been called compared to the Context object which keeps a distinct count value for each function.

For more information check this article: [Storing Data in Node-Red Variables \(stevesnoderedguide.com\)](http://stevesnoderedguide.com)

Using CLICK with Node-Red

CLICK Read, CLICK Write, and CLICK System Info. The System info block is just a read with additional tools to understand what you are reading. All three of these blocks ONLY ACCEPT and PROVIDE Simple Arrays. You can pass in a list of Boolean, or numbers, but it must be in a simple array; [value1, value2, value3]. Even a single value must be passed between the CLICK and Node-RED as an array; [value].



Here again the JSONata tool and a JavaScript Function block are the two easiest ways to convert your information to an array. A command as simple as

```
JavaScript Function
    Age = [person.age];
```



Will convert the number in person.age to an array – simply because the brackets define the value as an array.

Working with Node-RED Custom nodes for CLICK

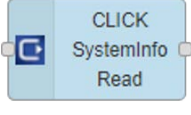
Inside Node-RED, there are 3 objects to share data with a CLICK PLUS PLC.

Node	Description
	This requires an array as input and writes a set number of values to the address specified.
	Accepts a starting memory address and a length. Populates an array starting with the first address. For example, X201, Len 4 will return an array [X201, X202, X203, X204].
	The same behaviors as CLICK Read, except this provides read-only access to SC bits and SD data registers. It will output an array of values. A register like RTC Day will output a simple Array containing a one-digit integer, while MAC ID will output an array with six 3-digit integers representing the MAC ID.

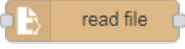
There are also 3 nodes which require specific configuration to work on the C2-NRED.

Node	Description
	This node writes a file to the C2-NRED filesystem. It has 1.5 GB available space (including your program). The file system has been locked down to prevent access or modification of any system files, but the following directory is available for user data: <i>/usr/local/nred-work/</i> In addition, you may write files to the SD Card if one has been inserted into the SD Card slot. The path to the SD card is: <i>/run/media/mmcblk0p1/</i> For example, to Write a file called Logs.txt, you would set the Filename property in the write file node to <i>/usr/local/nred-work/logs.txt</i>
	This node reads the data written to a file created by the write file node.
	This node will initiate a flow when data is written to a file by the write file node. It outputs the name of the file that was modified.

Here are some examples of data type conversions in Node-RED:

Converting data into an Array to Write to CLICK

Each of these CLICK operations accepts an array. To use them, you have to set the output of the prior operator to send an array, or you have to add a conversion element. The “Join” statement is generally the easiest, but you may use any of these functions:

- Join

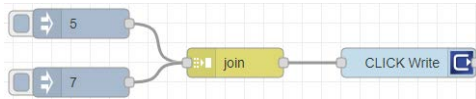

Join allows a user to combine one or more inputs into an array which will be sent to the CLICK memory.

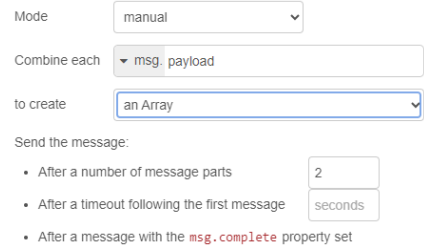

- Function



```
//msg.payload = “5” seconds. We want to send 5000ms to a timer value in the CLICK  
msg.payload=[ msg.payload*1000 ];  
return msg;  
//msg.payload now contains an array with a single value [5000]
```

The brackets convert the value to an array and even allow you to apply math inside the brackets. In this case, we’re converting the number of seconds to milliseconds before sending to the CLICK.

- Change

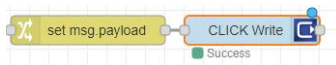

If the msg.payload is a constant, you can use the append function to append it to an array.

- The Change block enables the use of [JSONata](#) to perform complex JSON queries and transformations. The J: indicates a JSONata operation.

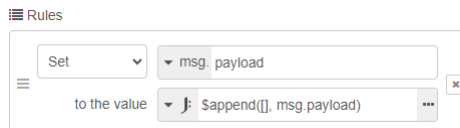

- Allow fixed values to be Set. This sets 2 bits.

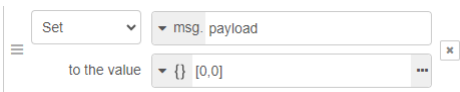

- Fixed Payload
Send a JSON string that looks like an array and it will be treated like one.



- Template

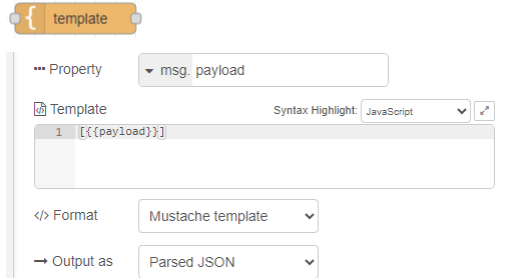

Performance

Testing basic performance with the following flow shows the time required to process a simple instruction in Node-RED:

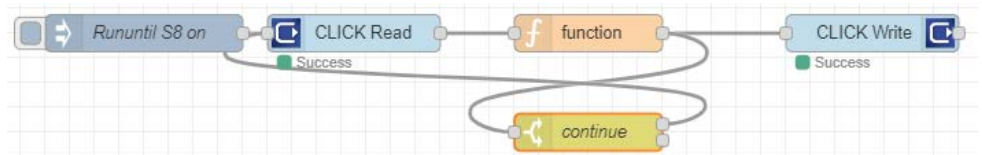

In this flow, Node-RED reads a set of Boolean values from the CLICK, executes a simple function and based on the state of the inputs, writes to the outputs. The time elapsed between the read and the write can vary based on a number of factors but is typically 5-10ms if no other flows are running. Occasional background tasks can cause that time to be as high as 50ms, and depending where in the scan cycle the read occurs, the time can drop to as low as 1ms. Of course if the C2-NRED module is processing multiple jobs and has a lot going on, this timing can be higher than 50ms.

Default Nodes in C2-NRED

See the embedded documentation in Node-RED for help. Node-RED provides an embedded help system with detailed usage information for every Node, including the CLICK Nodes. Drag a Node onto the canvas and open the help from the right panel.

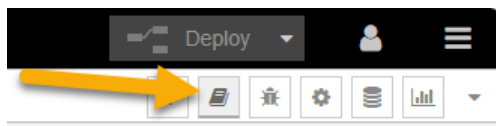

Troubleshooting

Node-RED application error:

In general, AutomationDirect cannot troubleshoot your specific application. There is a rich Node-RED community at the Node-RED.org website where you can find more resources and a supportive User-Forum. To help with your troubleshooting, however, we will include a list of common symptoms and resolutions here.

- **Symptom:** “RequestError: self-signed certificate in certificate chain”

```
9/26/2023, 11:08:09 AM node: call weather string
msg: error
"RequestError: self signed
certificate in certificate chain"
```

Resolution:

C2-NRED has a problem with its time server. Sync the clocks with the CLICK PLUS Host.

- **Symptom:** “RequestError: getaddrinfo EAI_AGAIN www...”

```
9/26/2023, 1:08:32 PM node: call ADC
msg: error
"RequestError: getaddrinfo EAI_AGAIN
www.automationdirect.com"
```

Resolution:

This means the C2-NRED cannot connect to the internet. Verify your IP address and that there is a path to the internet. It could also mean the C2-NRED DNS server isn't configured correctly. Open the C2-NRED Setup from your CLICK programming software and configure the DNS Server for the module. A Common DNS Server hosted by Google is 8.8.8.8 and the alternate address is 8.8.4.4. You may have to clear your DNS settings for this to take effect. Open the CMD prompt and enter `ipconfig /flushdns`.

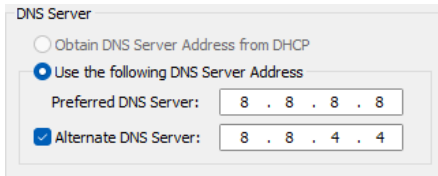

- **Symptom:** Cannot access the Node-RED Dashboard

Resolution:

The Dashboard URL is case sensitive (i.e. `http://192.168.137.122:1880/ui/`).

Ensure you are not blocked by the IP Whitelist in the C2-NRED Module Configuration (Allow List).

- **Symptom:** “ConnectionError: Failed to connect...”

```
11/1/2023, 11:59:15 AM node: 5c1936f0202fd51e
msg: error
"ConnectionError: Failed to connect to
192.168.0.135:1433 in 15000ms"
```

Resolution:

If your network is not configured for “Network Discovery” which allows devices on the network to talk to each other, you may see this “ConnectionError”. Another possible cause is the device you are trying to connect to is not accepting connections.

To fix it, adjust the network settings:

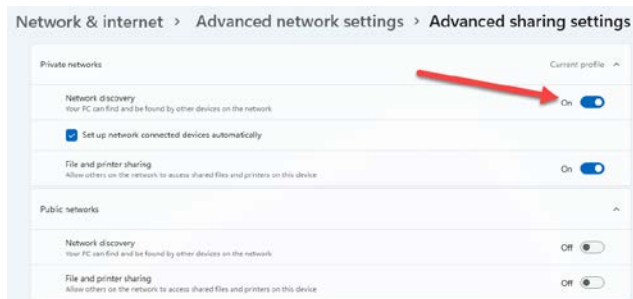

- **Symptom:** Failed to install: [Module name]

In the debug panel, the following messages appear:

“Installation of module [module name] failed:”

“npm ERR! code CERT_NOT_YET_VALID...”

```
11/1/2023, 11:25:48 AM
msg : string[62]
"Installation of module node-red-contrib-mssql-
plus-box failed:"

11/1/2023, 11:25:48 AM
msg : string[42]
"-----"

11/1/2023, 11:25:48 AM
msg : string[320]
"npm ERR! code CERT_NOT_YET_VALID+npm ERR!
errno CERT_NOT_YET_VALID+npm ERR! request to
https://registry.npmjs.org/node-red-contrib-
mssql-plus-box failed, reason: certificate is
not yet valid+npm ERR! A complete log of this
run can be found in:+npm ERR!
/usr/local/nred/.npm/_logs/2000-01-
02T02_18_20_555Z-debug.log+"

11/1/2023, 11:25:48 AM
msg : string[42]
"-----"

11/1/2023, 11:25:48 AM
msg : error
"Error: Install failed"
```

The log file will look like this:

```
-----
2023-11-21T16:08:49.271Z Install : node-red-contrib-aedes 0.11.1
2000-01-05T02:23:26.325Z npm install --no-audit --no-update-notifier --no-fund --save --save-prefix=- --production
--engine-strict node-red-contrib-aedes@0.11.1
2000-01-05T02:23:57.820Z [err] npm
2000-01-05T02:23:57.832Z [err] ERR! code CERT_NOT_YET_VALID
2000-01-05T02:23:57.832Z [err] npm ERR! errno CERT_NOT_YET_VALID
2000-01-05T02:23:57.944Z [err] npm
2000-01-05T02:23:57.946Z [err]
2000-01-05T02:23:57.947Z [err] ERR!
2000-01-05T02:23:57.952Z [err] request to https://registry.npmjs.org/node-red-contrib-aedes failed, reason: certificate
is not yet valid
2000-01-05T02:23:57.992Z [err]
2000-01-05T02:23:57.994Z [err] npm
2000-01-05T02:23:58.000Z [err] ERR! A complete log of this run can be found in:
2000-01-05T02:23:58.000Z [err] npm
2000-01-05T02:23:58.005Z [err] ERR! /usr/local/nred/.npm/_logs/2000-01-05T02_23_57_960Z-debug.log
2000-01-05T02:23:58.089Z rc=1
```

Resolution:

One possible cause is the RTC time in the CLICK PLUS PLC is not set correctly. Adjust the clock in the PLC to match your PC time. The C2-NRED module shares a clock with the PLC.

Fast blink on the C2-NRED Module:

The “OK LED” on the top of the C2-NRED module will blink slowly while it is starting up or after a reload of the CLICK ladder program. That is normal and does not indicate a problem. It will blink at about twice the normal rate to indicate the C2-NRED module is not enabled.

A Blinking Red Error LED indicates no project has been loaded into the PLC

C2-NRED Module Configuration (Slot0)

Network Address Configuration

- Obtain address from DHCP
- Use default fixed address
- Use the following IP address
 - IP Address: 192 . 168 . 0 . 146
 - Subnet Mask: 255 . 255 . 255 . 0
 - Default Gateway: 192 . 168 . 0 . 1

DNS Server

- Obtain DNS Server Address from DHCP
- Use the following DNS Server Address
 - Preferred DNS Server: 8 . 8 . 8 . 8
 - Alternate DNS Server: 8 . 8 . 4 . 4

Security Options

- Enable Response to Ping from other devices
- Enable user to add nodes from Network
- Enable Allow List
 - Allow List Setup...

Port Management

- Port Management Setup...

Enable Node-RED ←

Enable Node-RED

TCP Port Number (1-65535): 1880 (Typically Port No. 1880)

URL: http://192.168.0.146:1880

Enable HTTPS

Key File:

Server Certificate File:

Enable Node-RED Accounts

Enable Node-RED Accounts

Add... Edit... Delete Count: 0/8

No.	Enable	Permission	User Name

Auto Logout Time(5-10,080min): 120 min
Default: 120min

Connecting your PLC over Wi-Fi:

CLICK PLUS PLCs have an extremely fast start up cycle. As a result, when you power on both the PLC and a router, the PLC will initialize before a router and may not be assigned an IP address. Power up your router first, then power up the PLC and other devices that use IP addresses. That way, the DHCP server in the router will assign addresses when those devices power up. If they power up before the router, they will get unexpected IP addresses (169.xxx.xxx.xxx). It can be more stable to disable the DHCP server in your router and assign fixed IP addresses to your components.

Be sure your connection to your Wi-Fi network is set to enable Network Discovery

On Windows 11, right click your network icon in the system tray to open– Network and Internet Settings

- Select your network connection Wi-Fi
- Select your Wi-Fi adapter properties and make sure it is set to “Private Network”
- Go back to Network and Internet
- Select Advanced network settings
- Select Advanced Sharing Settings
- Verify that Network Discovery is On

This configuration will ensure the C2-NRED module can connect to devices and your PC is discoverable on the network.

CLICK Project Loader

When you save your ladder project using the CLICK programming environment it creates a .ckp project that includes the following data:

- Ladder project
- CLICK project file (Rung Comments, and general project configuration)
- Initial data

The project loader also saves the following data to a .cklx file:

- Everything in the ckp file
- CLICK PLC Firmware (so a restore is guaranteed to have the correct firmware)
- C2-NRED configuration parameters (including IP address, allow/block lists, enable, usernames and passwords, certificate info)
- C2-NRED OS, Firmware and DB
- C2-NRED Program flows
- 3rd party Nodes

Tested 3rd party nodes for compatibility purposes:



NOTE: Testing indicates these will install correctly. ADC does not support or warrant any third party nodes.

NODE NAME	Purpose	Node 14.18.1
node-red-contrib-google-oauth2 (0.3.2)	Use OAuth2 to connect to Google APIs	Corrupts http request - do not install
node-red-contrib-aedes (MQTT Broker) (0.11.1)	Create a MQTT Broker so you don't need a separate server. This requires opening a TCP port to 1883	11 min to install
node-red-node-sqlite (1.1.0)	Install SQLite on device. (Gives a structured way to store/retrieve data collected by the PLC. Connect to this DB from a PC directly to query/retrieve the data)	Pre-Installed
node-red-contrib-cip-st-ethernet-ip (2.0.3)	Create an Ethernet IP Client. Rockwell Addressing	Fail - causes C2-NRED module to crash
node-red-contrib-cip-ethernet-ip (1.1.3)	Interact with Allen Bradley / Rockwell PLCs using the EtherNet/IP Protocol	Success
@serafintech/node-red-contrib-eip-io 1.2.1	Create an Ethernet IP Client using standard addressing	Success
node-red-contrib-airtable (0.1.2)	Connect to an Airtable Base	Success (2:20 install)
node-red-contrib-ip (1.0.1)	Return the public IP address	Success
node-red-contrib-hostip (0.0.3)	Return the local IP Address	Success
node-red-contrib-modbus tcp (1.2.3)	Communicate with a Modbus TCP Server	Success
Node-red-contrib-modbus (5.31.0)	Communicate with a Modbus Server	Success
node-red-contrib-mssql-plus-box (0.1.4)	Connect and run queries against a SQL or Azure SQL server	Success
node-red-contrib-alexa-remote2-v2 (3.10.5)	Connect to Alexa. This is the same as node-red-contrib-alexa-remote2 except it is fully configured in the Node-Red interface. This requires opening a TCP Port to 3456	Success (2:40 install)
node-red-contrib-bacnet (0.2.5)	Read and Write to a Bacnet Network	Success
node-red-contrib-fs-ops	Read and operate on the file system. *Note: Most of the folders on the C2-NRED module are locked for system stability and security. The user may access: C2-NRED memory at /usr/local/nred-work/ C2-NRED SD Card at /run/media/mmcbk0p1/	Success (1:50 install)
node-red-contrib-ui-upload	Implement a file upload control on the dashboard to get files onto C2-NRED	Success (~2 minute install)
node-red-contrib-murr-impact67pro-iolink-api	MurrElektronik	Success (~1:30 minute install)
node-red-node-serialport	Add Support for a serial port on C2-NRED	Fail - Not supported in hardware

Use the link below to identify and generate a link to the latest compatible version of any Node-RED module:

<https://automationdirect.github.io/CLICK-PLC/Node-RED/C2-NREDModuleVersionCheck/CompatibilityCheck.html>

This utility lets you enter a Node-RED module name and it will generate a download link for the best version compatible with the C2-NRED.

Getting Your Project Ready for Production

As you add external modules, follow these steps to create an offline backup of each module added to your project. This will speed up the process of restoring your Node-RED system after a firmware update, and it will protect your project from version changes if the module author modifies or deprecates functionality you are using.

1. Backup all modules used in your project.
 - a. Find the name and version of the module you have added to your Node-RED project.
 - b. Open the “Hamburger Menu” at the top right of the screen and select “Manage Palette.”
 - c. You’ll see a list of modules included in your project.

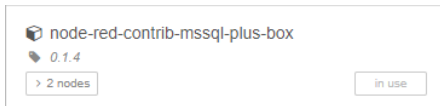

- d. Copy the name and version number of the module e.g. node-red-contrib-mssql-plus-box 0.1.4
- e. Create a URL with the name and version – follow this pattern:

[https://registry.npmjs.org/**node-red-contrib-mssql-plus-box**/-/**node-red-contrib-mssql-plus-box-0.1.4**.tgz](https://registry.npmjs.org/node-red-contrib-mssql-plus-box/-/node-red-contrib-mssql-plus-box-0.1.4.tgz)

Where the **red** lettering is the name of the module, and the **blue** is the version number.

- f. Copy/Paste that URL into your browser. It will download the source file of that module to your default downloads folder. Copy the download to your project folder on your PC.

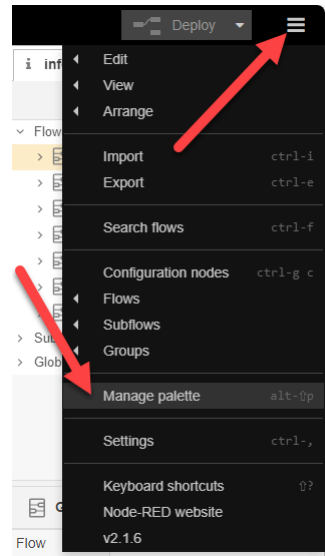

2. Make a backup of all Flows.
 - a. Open the “Hamburger Menu” at the top right of the screen and select Export.

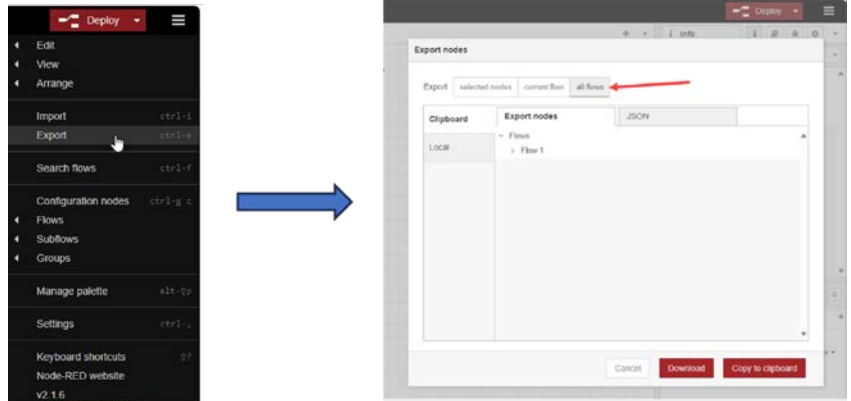

- b. Select “all flows” and “Download”. Save the Flows to your project backup folder.
3. After a firmware update (BEFORE YOU RESTORE YOUR FLOWS), you’ll need to restore all modules you had added to your project. You can EITHER redownload them from NPMJS or import them from your backup folder. It is recommended that you import modules from your backups to ensure you are using the same version with which you built and tested your project. You will likely need internet access to complete this step. Even if you have a backup of the modules used in your project, those modules MAY contain dependencies on additional libraries. When you install these (even from disk), Node-RED may call npm.js to load additional libraries.
 - a. To import from a backup location, open the “Hamburger Menu” and select “Manage Palette”.
 - b. Select the Install tab and click the “Import” button.

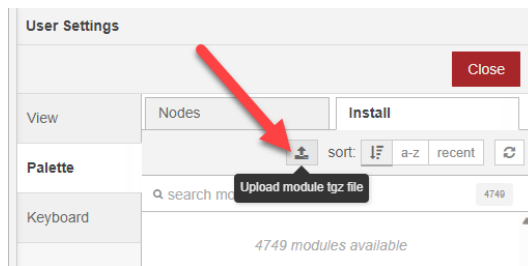

- c. Browse to your project folder where you have backed up your modules and reload each module.
4. AFTER YOU HAVE RESTORED 3rd PARTY NODES, Import your Flows.
 - a. Open the “Hamburger Menu” and select “Import”.
 - b. Click “select a file to import” and select the backup file with your flows. Click Open on the file selector and Import on the Import Nodes window.

C2-OPCUA OPC UA Server Module

Introduction

What is OPC UA

OPC UA stands for Open Platform Communications – Unified Architecture. It is not the same as the original OPC (OLE-Object Linking and Embedding for Process Control). In an OPC UA system, there are Servers that gather and collect data then serve it up to Clients that receive the data. OPC UA is a supervisory protocol. It is NOT meant for high-speed real time control systems. A fast OPC UA system will have a 100ms update rate. Machine logic should reside on the machine under control of the OPC UA servers. However, the OPC UA Client serves a very important role of providing global oversight—typically as part of a SCADA system, or system-wide monitoring system.

OPC UA (Open Platform Communications Unified Architecture) is widely used across industries that require reliable, secure, and standardized data exchange between devices, systems, and applications. Key industries and organizations that use OPC UA include:

1. **Manufacturing:** Factories and industrial automation systems, especially in sectors like automotive, aerospace, electronics, and pharmaceuticals, use OPC UA for machine-to-machine (M2M) communication, data exchange, and integration of devices on the factory floor.
2. **Oil and Gas:** Used for remote monitoring, data collection, and control of processes like drilling, extraction, and refining, allowing safe, real-time data exchange between field devices and control centers.
3. **Energy and Utilities:** Power plants, renewable energy sources (like wind and solar farms), and utility companies use OPC UA for integrating systems, monitoring operations, and optimizing energy management.
4. **Smart Cities:** OPC UA is often found in applications for building automation, traffic control, water management, and public safety, facilitating interoperability between various IoT devices and systems in smart infrastructure.
5. **Pharmaceuticals and Life Sciences:** Critical for ensuring compliance with regulatory standards by enabling precise monitoring and control of processes in drug manufacturing and other life sciences operations.
6. **Food and Beverage:** Provides standardization and real-time data exchange to improve efficiency, product quality, and traceability in production processes, from packaging to quality control.
7. **Transportation and Logistics:** Used for managing and tracking assets, monitoring vehicle data, and coordinating transportation networks, especially in smart warehouses and logistics hubs.
8. **Healthcare:** Hospitals and medical facilities use OPC UA in equipment and facility management systems for secure data transfer and integration of medical devices and systems.

As an example of where OPC UA fits, think of a railroad station. Within the station, train

location and switchgear status must be known. At a central hub the status of all systems in all stations must be visible. Due to the distance between stations, each station is connected to the public internet and the data is transmitted using TLS encryption to prevent man-in-the-middle attacks and to ensure data privacy. OPC UA offers both the performance and security necessary for this type of large, distributed monitoring and control system. Protocols such as Modbus, or EtherNet/IP are certainly fast enough but lack standard encryption. MQTTs is fast enough and secure, but since the packets are unstructured, it would take significant architectural design and any device added to the system would need custom programming to interpret or generate a data packet. OPC UA offers the security and structure that allows any OPC UA server to be easily added to the network.

There are two major benefits of using OPC UA over other communication protocols:

1. OPC UA is an Open Standard. This means that the protocol is free to use, and the specs have been published to the community. Because of this, it enables any device that is an OPC UA server to publish data, and any device that is an OPC UA client to read that data. The intent is to facilitate interconnectivity and tear down manufacturer specific walled gardens.
2. OPC UA is secure. When comparing OPC UA to other standards like Modbus and EtherNet/IP, OPC UA enables both encrypted data transmission AND client password requirements to access the data. If you look at Modbus, or EtherNet/IP, any device that you plug into your OT (Operations Technology) network can read the connection data for the network, then read and write data to your control system. While this was the generally accepted approach in the 90's, with the advent of global connections and nation state hackers, open network protocols are no longer the best method of establishing machine to machine communications.

What is the C2-OPCUA

The C2-OPCUA is a CLICK PLUS PLC Slot Module that is an OPC UA server. It can securely read all of the data registers in your CLICK PLC and provide access to those registers using the OPC UA communication standard. The C2-OPCUA Modules runs the [Embedded 2017 UA Server Profile](#). Version 1 of the C2-OPCUA does not support the full command set for OPC UA. This version supports data access features and security features; specifically authentication (either anonymous or with name and password) and security (sign and encrypt, sign only, or none). It does not support historical data access (historization), alarms and conditions (events), or UDP Pub/Sub features.

- ✓ Data Access: UA Part 8: DataAccess - 4 Concepts
- ✓ Encryption and Authentication: OPC UA Security architecture
- ✗ Historization: UA Part 11: Historical Access
- ✗ Alarms and Conditions: UA Part 9: Alarms and Conditions - 4 Concepts
- ✗ Pub/Sub: UA Part 14: PubSub - 4 Overview

System Requirements

- **Hardware:** The C2-OPCUA module is compatible with slot 0 or slot 1 of any CLICK PLUS PLC with one or two option slots.
- **Software:** Requires CLICK Programming software version 3.70 or above.
- **Network:** 10/100 Ethernet TCP/IP network

Installation



NOTE: If your CLICK PLUS PLC Firmware is below version 3.70, update the firmware in the PLC prior to installing the C2-OPCUA module.

Follow the instructions in the “Install the CLICK Programming Software” section of Chapter 1 to get the latest version of the CLICK Programming software installed on your PC. Refer to the CLICK PLUS application help files for more information:

[CLICK Help Version 3.70 - Introduction \(automationdirect.com\)](#)

After powering on and connecting to the CLICK PLUS PLC from the CLICK Programming Software, you must update the firmware to get both the CLICK PLUS PLC and the C2-OPCUA module up to the release version of firmware.

It is strongly advised to update the CLICK PLUS PLC firmware BEFORE installing the C2-OPCUA Module.

Follow these steps:

1. Ensure you have 24VDC wired to the CLICK PLUS PLC.
(Do not use the USB low power mode.)
2. BEFORE you install the C2-OPCUA module, connect to the CLICK PLUS PLC and update the firmware.
3. Power off the CPU.
4. Install the C2-OPCUA module, following the hardware installation instructions in the “Installing Option Slot Modules” section of Chapter 3.
5. Restore power.
6. Update the firmware again—this time it will update the C2-OPCUA firmware.

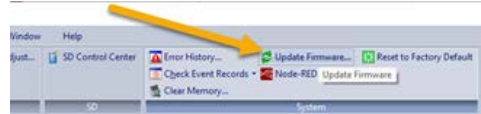

Communication

Once you have installed your C2-OPCUA module, you will need to connect to it. There are two primary connection methods:

Ethernet Only* — Connect your PC, and each Ethernet enabled module to a switch. All modules can be accessed over the same network.

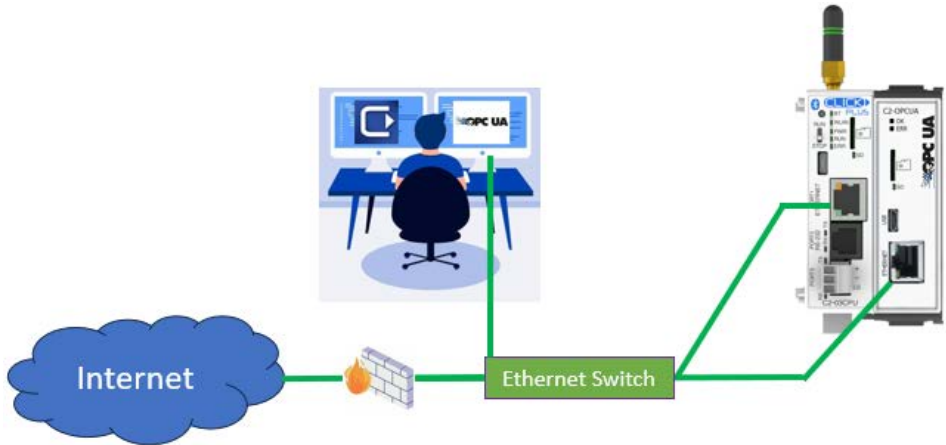

*This is the recommended approach due to its simplicity and speed.

USB and Ethernet — Connect the C2-OPCUA module to your network switch and connect to the CPU using USB. This allows simple programming and configuration using USB, but the C2-OPCUA module must be connected to the network.

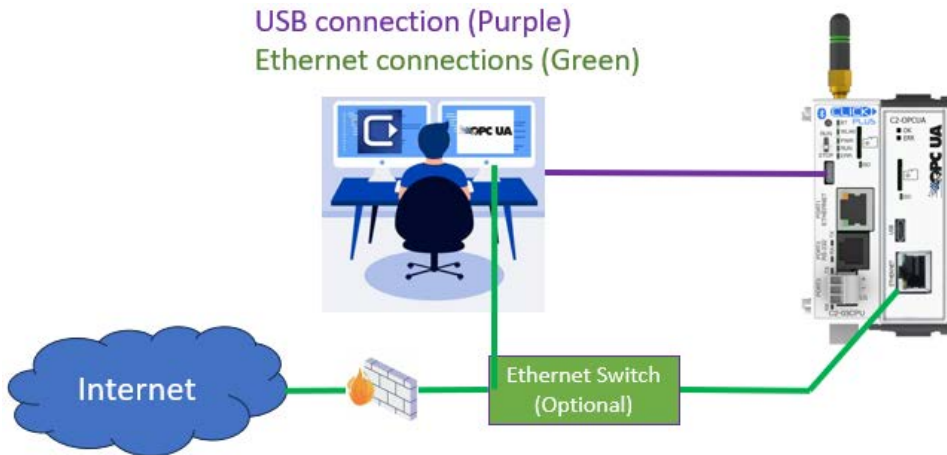

NOTE: The USB port on the C2-OPCUA module is used for backup/restore and factory default communications; it cannot be used for OPC UA communications.

Security

Before you get started configuring OPC UA, it is helpful to understand how the OPC UA security configuration works.

Definitions

Certificate — A luggage tag for your data. It contains information about the company and who owns the client or server. In the case of a web site, the certificate tells you who owns the web site(domain). It also contains information about how the server can encrypt data so the client and server can find a mutually agreeable method to encrypt communications.

Application Instance — An OPC UA Application (like the C2-OPCUA) installed on a single machine is called an Application Instance. Each instance must have its own Certificate which it uses to identify itself when connecting to other application instances. Each Application Instance has a unique URL.

Certificate Authority (CA) — Any publisher that generates certificates. A useful analogy is to compare certificates to a college ID. That ID is recognized by its issuer (the college) and entities on campus but not by businesses away from the college. On campus, people recognize the ID and trust it is valid. Away from campus, there is no trust, so the ID is not accepted. There are many levels of CAs ranging from Microsoft to any individual who wants to create them for their own system installations. All certificates created by any CA are valid as long as all entities in a transaction trust the CA that created those certificates.

Root-Certificate — A CA will generate a special type of certificate that can be used to authenticate all certificates they create. A root-certificate is used to verify other certificates are authentic, and unchanged.

Self-Signed Certificate — A Self-Signed Certificate is a certificate where the user is the Certificate Authority. These Certificates can be created by anyone, but they are only respected locally. Typically self-signed certificates are only useful in situations where the client and server are both internal and don't need a public CA to verify the identity of the owner of the Client or Server.

Authentication — Verify that messages received are from a known sender, and messages sent go to the intended recipient. There are various methods used to authenticate a sender. Username and password is one common way, but certificates can also be used to verify a sender. In that case, the recipient will use a root certificate from the sender's CA to validate the sender's certificate is authentic. The certificate itself will contain the senders identity.

Encryption — A mathematical method that uses a secret code known as a "key" to convert a plain text message to a coded string known as a Cipher. Encryption can use symmetric keys, where the sender and receiver use the same key to encrypt and decrypt messages. They can also use asymmetric encryption where the sender will use a public key to encode a message and the receiver will use a private key to decode the message.

Hash — A one way encryption. When a message is hashed, it cannot be decrypted. Every time the same message is hashed, it will generate an identical string. In secure communications, a hashed version of a message is included with the original message. The recipient will hash the original message and compare it to the hash sent. If they are not identical, the original message was altered and the message will be rejected.

Certificates provide two levels of security: authentication and encryption. In OPC UA, these are determined by a selection to either "Sign" (authenticate) or "Sign and Encrypt".

Below is a high level (simplified) description of the process.

1. The client makes a request to a server to start a conversation.
2. A server sends a certificate to the client. The certificate contains information about the owner of the server, and dates that the certificate is valid along with a public key.
3. The client and server then agree on an encryption method.
4. The client uses the public key from the server's certificate to encrypt messages sent to the server and sends its own certificate with the client's public key to the server.
5. The server will use the Client's public key to encrypt messages sent to the client.
6. All messages between devices are now encrypted.

Project Configuration

Once the firmware is up to date, you must enable the C2-NRED in order to begin. See the [C2-OPCUA Module Configuration](#) topic in the online help for details on configuring the module.

Time (RTC)

After the C2-OPCUA module is configured, **BE SURE TO SYNC THE PLC TO YOUR PC CLOCK!** The C2-OPCUA module shares a clock with your CLICK PLUS PLC. Be sure to update the time in the PLC. Click the PLC tab at the top of the CLICK programming software. Then click “Calendar/Clock Adjust”. If the time is wrong, it may impact the ability of the C2-OPCUA module to authenticate certificates and function appropriately.

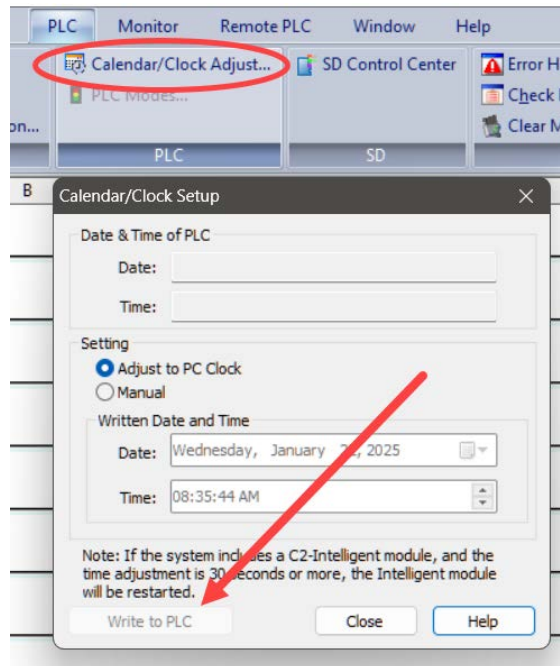

Troubleshooting

We recommend the [UaExpert software](#) from Unified Automation to aid in troubleshooting your OPC UA server. The software provides a full-featured OPC UA client that can test interactions with the C2-OPCUA. To establish communication between the client software and the C2-OPCUA server, please ensure that the security and authentication settings match between the two.

UaExpert Client Software

C2-OPCUA Configuration

Add OPCUA Account

Enable Authentication

No.	Enable	Username

Note: "Enable Authentication = OFF" is "Anonymous".

- **Symptom:** Red LED on the OPC UA module is blinking

Resolution:

Check the Error History in the CLICK Programming Software. Error code 2155 indicates the Certificate has expired. Check the PLC time is within the validity period of the certificate.

MAINTENANCE



In This Chapter...

PLC Maintenance	6-2
-----------------------	-----

PLC Maintenance

Although the CLICK PLUS PLC requires very little maintenance, setting up a routine maintenance schedule will ensure the longevity of the PLC in your application. We suggest checking the following items as part of a quarterly or bi-annual preventative maintenance schedule.

Check LED Indicators

Check the PWR and ERR LED indicators on the PLC and I/O modules. If the PWR LED indicator is off or flickering, or if the ERR indicator is on or flickering, refer to Chapter 6: *Troubleshooting* for more information.

Project Backup

Saving a copy of the project file during routine maintenance ensures that you will have a fairly up-to-date backup copy of the PLC program. Although the CLICK PLUS PLC programming software can upload the complete project from the PLC anytime the PLC is operable, it is wise to maintain a project backup in case the PLC becomes inoperable and has to be replaced. The backup file of the project can then be downloaded into the new PLC.

Check Operating Environment

Make sure that the CLICK PLUS PLC is operating within the proper temperature range (0–55°C; 32–131°F).

Make sure that the CLICK PLUS PLC is operating within the proper humidity range (30–95% RH, non-condensing).

Make sure that the CLICK PLUS PLC operating environment is free of corrosive gases.

Check Operating Voltage

Check the input voltage that is powering the CLICK PLUS PLC to make sure that the voltage is within the appropriate range (20–28 VDC).

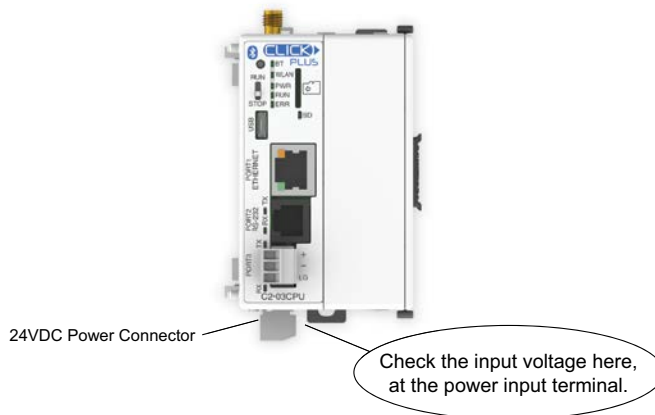

Check the input voltage for the I/O module terminal blocks. Refer to Chapter 2: *Specifications* for the voltage specifications of the various I/O modules.

Check Physical Condition

Check the PLC and modules for distorted, warped, or discolored cases and burnt odors that could indicate overheated components.

Check to ensure that none of the PLC and module cooling vents are clogged or blocked by dust or debris. Make sure that there is sufficient unobstructed heat dissipation space around the PLC as shown in *Chapter 3: Installation and Wiring*.

Ensure that all of the CLICK PLC modules are connected together tightly. Also make sure that all communication cables, wiring, and terminal blocks are connected properly.



WARNING: The CLICK PLUS PLC does not have hot swap capability. Do not disconnect or replace any I/O modules without first shutting off power to the PLC unit.

Check Project Functionality

During routine maintenance, check the functionality of your project (PLC program). Make sure the system or equipment that is being controlled is operating as intended.

Check the PLC Program from the CLICK Programming Software

You can read the following PLC information from the CLICK programming software:

- System configuration.
Check whether or not the PLC unit is recognizing the actual I/O configuration correctly.
- Error history.
Check whether or not any errors occurred recently.
- Scan time.
Check whether or not the scan time is normal, and if the minimum and maximum scan times are reasonable. Refer to Chapter 2: Specifications for information regarding scan times.

TROUBLESHOOTING



CHAPTER 7

In This Chapter...

Troubleshooting Direction	7-2
PLC unit Troubleshooting	7-3
Bluetooth Troubleshooting	7-5
Wireless LAN Troubleshooting	7-6
USB Troubleshooting	7-7
SD Card Troubleshooting	7-8
Power Supply Troubleshooting	7-9
I/O Module Troubleshooting	7-10
Resetting to Factory Defaults	7-14
Troubleshooting Electrical Noise Problems	7-15
Error Codes	7-16

Troubleshooting Direction

Use this section to figure out where to start when troubleshooting CLICK PLUS PLC problems.

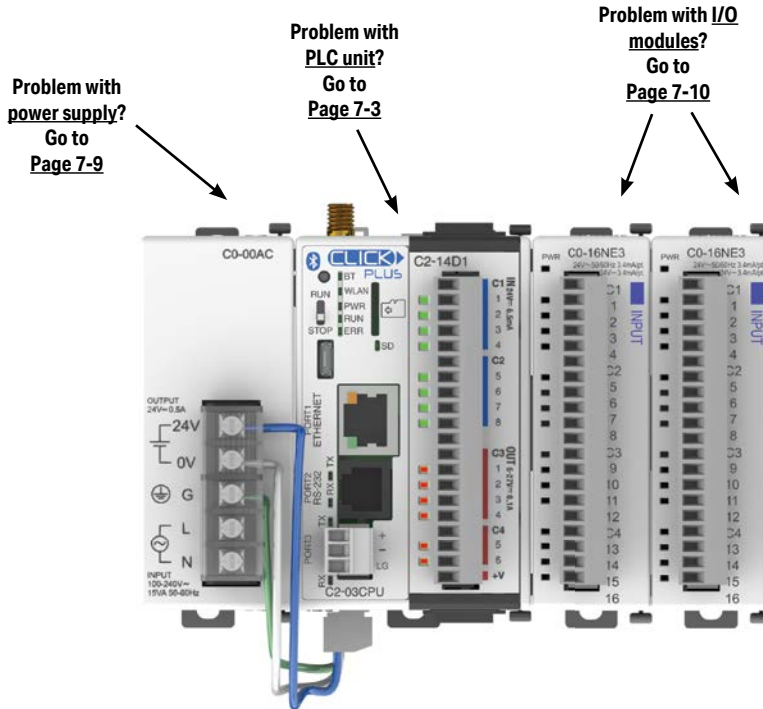

PLC unit Troubleshooting

PLC unit issues are grouped according to their function. Use the illustration below to find the appropriate document page numbers for issues with different PLC unit functions.

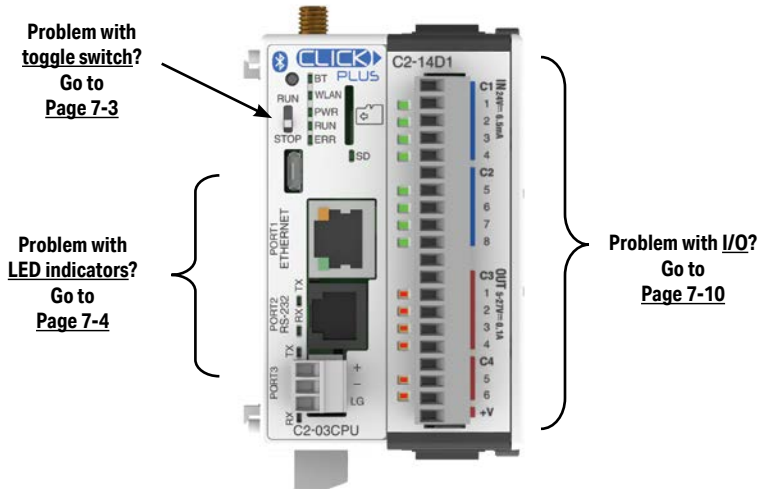

Toggle Switch

Switch is in RUN position

When the toggle switch is in the RUN position, the PLC unit should normally be in Run mode (indicated by the RUN LED being ON), unless the PLC has been placed in Stop mode by a peripheral device through one of the communication ports. To put the PLC unit in Run mode, move the toggle switch to the STOP position and then switch it back again to the RUN position. If the RUN LED then remains off, check the PWR and ERR LED indicators per the chart shown below.

LED	Status*	Necessary action
PWR	OFF	There is insufficient power for the PLC unit. Check the power cable and input voltage.
ERR	ON	There is an error in the PLC unit. Connect the CLICK programming software to read the error information. See the "Error Codes" section at the end of this chapter for error message instructions.

** If you see LED indications different from the ones shown in this table, refer to the "LED Indicators Troubleshooting" section for further explanations.*

Switch is in STOP position

When the toggle switch is in STOP position, the PLC unit should be in Stop mode (indicated by the RUN LED being OFF). Cycle power to the PLC. If the PLC unit starts up in Run mode, with toggle switch in STOP position, it means the PLC unit does not recognize the toggle switch position correctly. Please replace the PLC unit.

Chapter 7: Troubleshooting

LED Indicators

The CLICK PLUS PLC performs many pre-defined diagnostic routines with every PLC scan, using onboard diagnostics that can detect various errors or failures in the PLC. LEDs on the face of the PLC will indicate for specific errors.

The 3 LEDs located next to the RUN/STOP switch power, (PWR, RUN and ERR) indicate the status of the PLC unit. The remainder of the LED indicators are discussed in later sections of Chapter 2.

LED	Status	Meaning	Necessary action
PWR	On	The PLC is powered correctly.	No action is necessary.
	Blinking	USB Low Power Mode, or the PLC input power is not sufficient.	If the PLC is connected to the PC via USB and has no other power source, no action is needed. If the PLC is connected to a power supply, check the voltage on the terminal located on the bottom of the PLC. The input voltage should be 20-28 VDC. Also check the power input wiring & terminal connections. The power supply may need to be replaced.
	Off	There is no power to the PLC.	Check the voltage on the terminal located on the bottom of the PLC. The input voltage should be 20-28 VDC. Also check the power input wiring & terminal connections. The power supply may need to be replaced.
RUN	On	The PLC is in RUN mode.	If the toggle switch next to the LED indicators is in RUN position, no action is necessary. If the toggle switch is in STOP position, cycle power the PLC. If the PLC unit starts up in Run mode, it means that the PLC unit does not recognize the toggle switch position correctly, and the PLC unit must be replaced.
	Blinking	The PLC is initializing the CO-04RTD or CO-04THM.	When a CO-04RTD or CO-04THM is installed in the CLICK PLC system, the RUN LED blinks for up to 11 seconds to indicate that the PLC unit is initializing the analog input module after power-up. If the RUN LED keeps blinking after the initial 11 seconds, power cycle the CLICK PLC system. If the symptom remains, replace the PLC unit and/or the analog input module.
	Off	The PLC is in STOP mode.	If the toggle switch next to the LED indicators is in STOP position, no action is necessary. If the switch is in RUN position and you want to put the PLC unit in Run mode, toggle the switch to STOP position and then back to RUN position. If the RUN LED stays off, connect the CLICK programming software to read the error information. See the "Error Codes" section at the end of this chapter for error message instructions.
ERR	On	There is an error.	Connect the CLICK programming software to check the error. See the "Error Codes" section at the end of this chapter for error message instructions.
	Blinking	There is a warning.	Warnings do not prevent the PLC unit from running. However, you should check what warnings are active. Connect the CLICK programming software to read the warning information. See the "Error Codes" section at the end of this chapter for error message instructions.
	Off	There is no error.	No action is necessary.

Errors (ERR LED on)

Errors which may cause the system to function improperly, perhaps causing a safety problem. The PLC will automatically switch from RUN Mode to STOP Mode. (In STOP Mode all outputs are turned off.) If the PLC is already in STOP Mode when an error is detected, the PLC will not allow a transition to RUN Mode until the error has been corrected.

Examples of errors:

- I/O module error
- System configuration error
- Memory check error
- Project file error

Warnings (ERR LED blinking)

Warnings that require attention, but do not cause improper operation. They do not cause or prevent any PLC mode transitions. The application program can use system control bits to detect warnings, and even take the system to an orderly shutdown or switch the PLC to STOP Mode if desired. Examples of warnings:

- Lost SRAM data
- Battery low voltage
- Battery Replacement Notification date has passed, if enabled in Battery Backup Setup

Bluetooth Troubleshooting

Check System Control relays and Data Registers in DataView and make sure Pairing is not disabled, or that the PLC is already paired. (SC60-SC63).

When pairing is started the Bluetooth LED blinks rapidly 8 times and then stays off

Cause

Bluetooth is disabled in the project. Or, Bluetooth is enabled in the project, but SC60 BT_Disable_Pairing may be turned On.

Corrective Action

Bluetooth is enabled when the PLC is in a Factory Default state. If Bluetooth was not enabled when the project was created, downloaded and the PLC put in Run mode, the Bluetooth will be disabled.

To enable Bluetooth, go to the Bluetooth Port Setup, select Enable Bluetooth and enter a password. Download the project. If the project was downloaded in Stop Mode, the new setting will not take effect until the PLC is put in Run mode.

Cannot Pair the mobile App with the PLC

Cause

In general, Bluetooth devices need to be within at least 20 feet line of site with each other to connect reliably.

Corrective Action

Bring the devices closer together.

If the antenna is inside an enclosure, you will need to open the door on the enclosure or install an external antenna such as the SE-ANT250.

Cause

Mobile Device app is not functioning properly.

Corrective Actions

Reset iOS or Android device - Turn the devices off or perform a hard reset.

Check that the app is the newest version available.

Reset Factory Defaults on PLC

Wireless LAN Troubleshooting

Check System Control relays and Data Registers in DataView and make sure Wi-Fi is not disabled or in an error state. (SC80-SC84, SD212-SD218)

Wi-Fi SSID is not listed in app

Cause

SSID broadcast is not enabled in Wi-Fi router.

Corrective action

Make sure that SSID Broadcast is Enabled in the router.

Cycle Power on Router

Check and see if SSID shows up on Mobile Device available Wi-Fi networks. If the network is listed, then perform a hard reset on the mobile device.

PLC does not connect to Wi-Fi

Cause

Electrically noisy environment

Corrective Action

802.11 Wi-Fi is susceptible to other radio signals or electrical noise produced by other electrical equipment such as other radios, variable frequency drives, high power equipment.

Use DataView to see the current value of SD218 WLAN_No_Connect_Status and check the helpfile for more information.

Take PLC and mobile device to an electrically quiet area and test. If devices connect, electrical noise source in the installation environment will need to be identified and the noise eliminated.

Cause

Distance to Wi-Fi Router/ Low Signal Strength

Corrective Actions

Wi-Fi distances are typically 150 to 300 meters depending on how open the area is. Electrical noise will reduce this distance. Bring the devices closer together.

If the antenna is inside an enclosure, you will need to open the door on the enclosure or install an external antenna such as the SE-ANT250.

Cause

Beyond the connection limit of the router.

Corrective actions

Reconfigure the router for more connections or disconnect some devices.

Cause

Router does not accept connections.

Corrective Action

Reconfigure Router to accept connections.

Disable MAC Filtering or add the new MAC into the whitelist.

USB Troubleshooting

Cannot connect PC to PLC over USB

Cause

Driver not installed on PC.

Corrective Action

Go to the Device Manager on the PC and make sure there is a listing for CLICK PLUS (COMx) under Ports (COM & LPT).

If it is just listed as USB Serial Device (COMx) then the CLICK driver is not installed properly.

- Disconnect the USB cable from the PC.
- Find and execute CLICK_USBDriver.exe on in the original download or on the original installation USB.
- Reconnect the USB cable.

If there is not a connection listed in the device manager, the cable could be defective or the USB port on the PC or PLC could be defective.

- Try a different cable
- Try a different port on the PC
- Replace the PLC

SD Card Troubleshooting

Check System Control relays and Data Registers in DataView and make sure the SD Card is Ready to Use and does not have an error or reached a file limit. (SC65-SC70, SD69)

SD Card Ready LED does not light up/Cannot log to SD Card

Cause

SD Card is Write Protected.

Corrective Action

Change Write Protection

Cause

SD Card Formatting and File allocation size are incorrect or SD Card size is too large.

Corrective Action

Make sure the SD Card meets the specifications in Chapter2 - Micro SD Card Slot Specifications

Cause

Defective SD Card

Corrective Action

Replace SD Card

Power Supply Troubleshooting

When the PWR LED is ON, the CLICK PLUS PLC is receiving enough power for operation. Verify the power input voltage at the bottom connector on the PLC unit; the input voltage should be 20–28 VDC.

The input voltage measures less than 20VDC

Remove the bottom connector from the CLICK PLUS PLC unit and measure the voltage again. If the voltage at the connector then measures more than 20VDC, the power supply cannot provide enough current for the CLICK PLUS PLC. Replace the power supply with a higher output current power supply. Check the power budget to determine the current required from the power supply (see below).

If the voltage still measures less than 20VDC with the connector removed from the PLC, and the power supply voltage is not adjustable, then the power supply cannot be used for the CLICK PLUS PLC. Replace the power supply with another one.

The input voltage measures greater than 28VDC

If the output current of the power supply is adjustable, decrease the output voltage. If the output voltage cannot be lowered to less than 28VDC, replace the power supply with another one.

How to check the power budget

You can use the programming software to check the power budget of the CLICK PLUS PLC:

- Connect the PLC to a computer running the CLICK programming software.
- From the software menus, connect the software to the PLC by selecting PLC and Connect...
- From the software menus, select Setup and System Configuration...
- The System Configuration Setup window opens, and displays the Power Budget in milliamps (mA) required by the PLC system. The PLC power supply must be capable of providing more current than the Power Budget amount.

I/O Module Troubleshooting

First, check the status of the PWR LED indicators on the I/O modules. If the PWR LED on the PLC unit is on, but there are I/O modules which have PWR LEDs that are off, check the connections between the modules. If the I/O module PWR LEDs remain off, replace those modules.

Troubleshooting input modules is slightly different from troubleshooting output modules. Please refer to the proper subsection:

- Input module troubleshooting
- Output module troubleshooting

Input Module Troubleshooting

The input modules (including the PLC built-in inputs) can have the following symptoms:

Symptom	Necessary Action
Input signal is on, but the LED indicator on the module is off.	Check the external power input voltage on the terminal block.
	Check whether the terminal block is attached correctly.
	If the input voltage is correct but the LED indicator is still off, replace the input module.
The LED indicator is on, but the PLC does not work as expected.	Check whether the PLC unit RUN LED is ON. If not, put the PLC in RUN mode.
	Check the I/O configuration with the programming software. (See "How to Check the I/O Configuration" on the next page.)
	Connect the programming software and check the X bit related to the input point that is on. (See "How to Check the I/O Status" later in this section for instructions.) If the X bit is off, replace the input module.

Output Module Troubleshooting

The output modules (including the PLC built-in outputs) can have the following symptoms:

Symptom	Necessary Action
The module LED indicator is ON, but there is no output.	Check the external power input voltage on the terminal block.
	Check whether the terminal block is attached correctly.
	If it is a DC sinking, relay, or AC output, check the voltage between the output and the common. If the output is working correctly, the voltage should be close to zero.
	If it is a sourcing output, check the voltage between the output and the 24 VDC input. If the output is working correctly, the voltage should be close to zero.
The module LED indicator is ON, but the output voltage is not correct, replace the output module.	If the LED indicator is ON, but the output voltage is not correct, replace the output module.
	Check whether the PLC unit RUN LED is ON. If not, put the PLC in RUN mode.
	Check the I/O configuration with the programming software. (See "How to Check the I/O Configuration" below.)
	Connect the programming software and check whether the Y bit related to the output point is ON. If the Y bit is not actually ON, use the override feature to manually turn the Y bit ON. (See "How to Check the I/O Status" on the next page.)
If the Y bit is ON, but the output is OFF, replace the output module.	If the Y bit is ON, but the output is OFF, replace the output module.
The module LED indicator is OFF, but the output is sending an ON signal to the field device.	Leakage current can be a problem when connecting field devices to I/O modules. False input signals can be generated when the leakage current of the output point is great enough to turn on the connected input device.
	To correct this issue, install a resistor in parallel with the input or output of the circuit. The value of this resistor will depend on the amount of leakage current and the voltage applied, but usually a 10k to 20k ohm resistor will work. Ensure that the wattage rating of the resistor is correct for your application.

How to Check the I/O Configuration

You can use the CLICK programming software to check the I/O configuration that the PLC is recognizing:

- Connect the PLC to a computer running the CLICK programming software.
- From the software menus, connect the software to the PLC by selecting PLC and Connect...
- From the software menus, select Setup and System Configuration...
- The System Configuration Setup window opens, and displays all of the CLICK module types the PLC recognizes that are connected in the PLC system.

Chapter 7: Troubleshooting

How to Check the I/O Status

You can use CLICK programming software Data View window to check the I/O status in the PLC unit.



WARNING: Only authorized personnel fully familiar with all aspects of the application should make changes to the program. Make sure that you thoroughly consider the impact of any changes to minimize the risk of personal injury or damage to equipment. Specifically, forcing inputs and outputs to their ON state will cause externally connected equipment to operate.

Open or create a data view window by selecting Monitor and Data View from either the menu bar, the Navigation window, or the Data View icon.

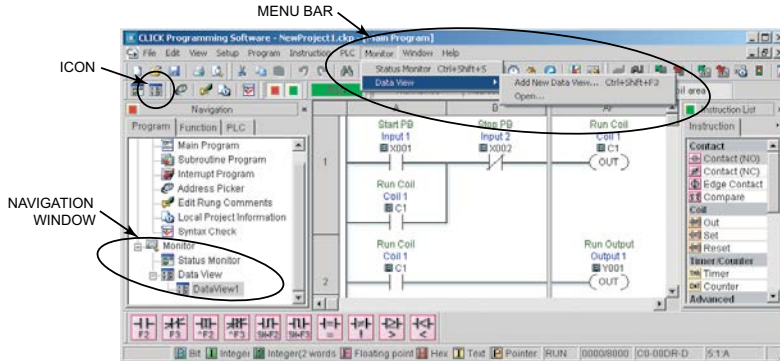

To add new memory addresses to a Data View window:

- Click on an empty Address field to bring up a small browser button.
- Click the browser button to open the Address Picker window.
- From the Address Picker window, click the Pickup Mode button, select the desired I/O or memory location, and then click OK to add that address into the data view.



No.	Address	Nickname	Current Value	New Value	Write	Viewing Format
001	X001	Input 1	Off			Bit
002	X002	Input 2	Off			Bit
003	SC7	1sec. Clock	On			Bit
004	C1	Coil 1	Off	On Off	Write	Bit
005	Y001	Output 1	Off	On Off	Write	Bit
006	Y002	Output 2	On	On Off	Write	Bit

To troubleshoot I/O from the Data View window:

- Connect to PLC unit
- Force outputs on/off, then check actual outputs to see whether they are actually on or off.
- Edit, Write All New Values, or double click individual output Write icon.
- Externally turn inputs on or off, then check their status in data view. Inputs cannot be forced from Data View.

Replacement of I/O modules



WARNING: The CLICK PLUS PLC does not have hot swap capability. Do not disconnect or replace any I/O modules without first shutting off power to the PLC unit.

Before replacing an I/O module, please consider the cause of the module problem. If you suspect that another device may have caused the failure in the module, that device may also cause the same failure in the replacement module. As a precaution, you may want to check power supplies or other devices connected to the failed module before replacing it.

Resetting to Factory Defaults

The CLICK PLUS CPU can be reset to factory default by any of the following methods, depending on device capabilities.

1) Use the Bluetooth Pairing Button on Bluetooth Capable PLC's

On the C2-02CPU and C2-03CPU, use the BT button on the PLC. To Reset the PLC to its factory default state press and hold in the BT Pairing Button on the front of the PLC for 5-6 seconds, until the BT LED begins flashing very fast.

2) Use CLICK Factory Default Tool

The CLICK Factory Default Tool is a separate software app installed with CLICK Programming Software v3.00 or later. It can be opened from the Start Menu of your PC.

In order to use the Factory Default tool, you must use a local USB connection.

This tool can be used with:

- C2-x - CLICK PLUS series
- C0-1x - Click Ethernet series

See the Help Files for more details on using the CLICK Factory Default tool.

3) Use CLICK Programming Software

See the Help File on details of using the CLICK Programming Software to Reset to Factory Defaults.

4) Use the Run/Stop Switch

- Power On the PLC with the RUN/STOP Switch in the STOP Position.
- Within 30 seconds, move RUN/STOP Switch from STOP to RUN three times then back to STOP.

STOP→RUN→STOP→RUN→STOP→RUN→STOP



NOTE: Use of the run/stop switch will only reset the processor. It will not reset any of the intelligent modules. To reset the intelligent modules, use the CLICK Programming software or the Factory default tool.

Troubleshooting Electrical Noise Problems

Electrical Noise Problems

Noise is one of the most difficult problems to diagnose. Electrical noise can enter a system in many different ways and can fall into one of two categories, conducted noise or radiated noise. It may be difficult to determine how the noise is entering the system, but the corrective actions are similar for both types of noise problems.

- Conducted noise is electrical interference introduced into the system by way of an attached wire, panel connection, etc. The interference may enter through an I/O circuit, a power supply connection, the communication ground connection, or the chassis ground connection.
- Radiated noise is electrical interference introduced into the system without a direct electrical connection, much in the same manner as radio waves.

Reducing Electrical Noise

Although electrical noise cannot be completely eliminated, it can be reduced to a level that will not adversely affect the system.

- Most noise problems result from improper grounding of the system. A good earth ground can be the single most effective way to correct noise problems. If a ground is not available, install a ground rod as close to the system as possible. Ensure that all ground wires are single point grounds, and are not daisy chained from one device to another. Ground other metal enclosures near the system. A loose wire can act as a large antenna, introducing noise into the system; so, tighten all connections in your system. Loose ground wires are more susceptible to noise than the other wires in your system. Review *Chapter 3: Installation and Wiring*, if you have questions regarding how to ground your system.
- Electrical noise can enter the system through the power source for the PLC and I/O circuits. Installing an isolation transformer for all AC sources can correct this problem. DC sources should be well-grounded, good quality power supplies.
- Separate input wiring from output wiring. Never run low-voltage I/O wiring close to high voltage wiring.

Error Codes

When there is an Error or Warning, the error code is stored in the System Data register SD1.

When an Error occurs during the operation, the CLICK PLUS PLC system goes to the STOP mode immediately and the ERR LED on the PLC unit turns on. On the other hand, when a Warning occurs during the operation, the CLICK PLUS PLC system stays in RUN mode and the ERR LED on the PLC unit starts blinking.

In the error code tables that follow, the Category column indicates whether the error code is an Error or a Warning. If any of the Warnings listed is critical for your control system, add an additional ladder program to put the CLICK PLUS PLC system in STOP mode when that specific Warning occurs. Here is an example.

Example

X102 turns on when the analog I/O module in the I/O1 position is missing external 24VDC input.

By turning the System Control bit SC50 on, the CLICK PLC system goes into the STOP mode.



PLC Error Codes					
Error Code	Status Flag*	Error Name	Category	Causes	Solutions
001	N/A	Power Fail	Error	Input Voltage is less than 20VDC.	Provide the correct nominal voltage of 24VDC. Recalculate the power budget and compare to your power supply available current.
101	SC20	I/O Module Error	Error	There are more than 8 I/O modules.	A CLICK PLUS PLC system can support up to 8 I/O modules. Remove any excessive I/O modules.
				At least one I/O module was added to the CLICK PLC during operation.	Power off the CLICK PLUS PLC and check the connection of the I/O modules. Then power on the PLC again. If the problem remains, connect the CLICK software to the PLC and check the System Configuration. If there is any I/O module that is not shown in the System Configuration, replace it.
				An I/O module has failed.	Connect the CLICK software to the CLICK PLUS PLC and check the system configuration. If there is any I/O module that is used in the PLC system but not shown in the System Configuration window, replace the I/O module.
102	SC21	System Config Error	Error	The current system configuration does not match the configuration saved in the project file.	Connect the CLICK software to the CLICK PLUS PLC and open the System Configuration window. Modify the current configuration of the PLC to match the configuration in the project file, or uncheck the 'Start-up I/O Config Check' option if you want to use the current configuration.

* The Status Flags are turned ON when the related errors occur.

Error code table continued on next page.

Error Codes (continued)

PLC Error Codes					
Error Code	Status Flag*	Error Name	Category	Causes	Solutions
103	SC22	I/O Config Error	Error	At least one I/O module was removed from the CLICK PLC during operation.	Power off the CLICK PLUS PLC and check the connection of the I/O modules. Then power on the PLC again. If the problem remains, connect the CLICK software to the PLC and check the System Configuration. If there is any I/O module that is not shown in the System Configuration, replace it.
				The PLC unit can not access one or more I/O modules.	Connect the CLICK software to the CLICK PLUS PLC and open the System Configuration window. If there is any I/O module that is used in the PLC system but not shown in the System Configuration window, replace the I/O module.
104	SC23	Memory Check Error	Error	There is a memory check error.	Power cycle the CLICK PLUS PLC. If the same error occurs again, download the project again and/or try the 'Reset to Factory Default' command. If the same error still occurs, replace the PLC unit.
105	SC24	Project File Error	Error	There is no project file in the CLICK PLC.	Download a project file into the CLICK PLUS PLC.
				The project file stored in the CLICK PLC is corrupted.	Download the project file into the CLICK PLUS PLC again.
106	SC25	Firmware Version Error	Error	The project file was written on a newer version of CLICK software. The firmware in the CLICK PLC is too old to execute the project.	Connect the CLICK software to the CLICK PLUS PLC and update the firmware of the PLC unit.
107	SC26	Watchdog Timer Error	Error	The PLC scan time exceeded the watchdog timer setup.	Connect the CLICK software to the PLC and check the maximum PLC scan time and the watchdog timer setup.
108	SC26	Interrupt Watchdog Timer Error	Error	The PLC scan time exceeded the watchdog timer setup.	The watchdog timer was exceeded while executing an Interrupt Program. Reduce the occurrences of Interrupts, or reduce the executing time of the Interrupt Programs to prevent this error.
109	SC31	Sub-processor Firmware Version Error	Error	The sub-processor contains a firmware version which does not match the main processor.	Connect the CLICK software to the CLICK PLC and update the firmware of the CPU module.
201	SC27	Lost SRAM Data	Warning	The data in the SRAM was lost while the CLICK PLC was powered off.	The Basic PLC units do not have a battery back-up, but they have a capacitor that will hold memory for a few days. The data in the SRAM is lost if the CLICK PLUS PLC is powered off for long enough for the capacitor to discharge. In this case, the PLC initializes the data in the SRAM automatically. This also applies to Standard and Analog PLC units if a battery is not installed.
202	SC28	Battery Low Voltage	Warning	Battery voltage is too low to retain data in the SRAM.	Replace the battery (ADC part #: D0-MC-BAT). Also, set the new battery installation date and the anticipated replacement date in the CLICK programming software if the Battery Replacement Notification option is selected. (Pull-down menu: Setup > Battery Backup Setup)
203	SC29	Battery Replacement	Warning	The anticipated battery replacement date has passed.	Replace the battery (ADC part #: D0-MC-BAT). Also, set the new battery installation date and the anticipated replacement date in the CLICK programming software. (Pull-down menu: Setup > Battery Backup Setup)

* The Status Flags are turned ON when the related errors occur.

Error code table continued on next page.

Error Codes (continued)

PLC Error Codes					
Error Code	Status Flag*	Error Name	Category	Causes	Solutions
204	SC30	Run Edit Project Error	Warning	The RUN Time Edit program download failed.	The program download was not completed. The PLC will continue in RUN with the previous program.
205	SC32	C2-DCM FW Version Error	Warning	The C2-DCM contains a firmware version that is incompatible the main processor.	Connect the CLICK software to the CLICK PLC and update the firmware of the CPU module.
301	X101	IO1 Module Error	Error	The analog I/O module in I/O1 position is not functioning.	Power cycle the CLICK PLUS PLC. If the same error occurs again, replace the analog I/O module.
302	X201	IO2 Module Error	Error	The analog I/O module in I/O2 position is not functioning.	Power cycle the CLICK PLUS PLC. If the same error occurs again, replace the analog I/O module.
303	X301	IO3 Module Error	Error	The analog I/O module in I/O3 position is not functioning.	Power cycle the CLICK PLUS PLC. If the same error occurs again, replace the analog I/O module.
304	X401	IO4 Module Error	Error	The analog I/O module in I/O4 position is not functioning.	Power cycle the CLICK PLUS PLC. If the same error occurs again, replace the analog I/O module.
305	X501	IO5 Module Error	Error	The analog I/O module in I/O5 position is not functioning.	Power cycle the CLICK PLUS PLC. If the same error occurs again, replace the analog I/O module.
306	X601	IO6 Module Error	Error	The analog I/O module in I/O6 position is not functioning.	Power cycle the CLICK PLUS PLC. If the same error occurs again, replace the analog I/O module.
307	X701	IO7 Module Error	Error	The analog I/O module in I/O7 position is not functioning.	Power cycle the CLICK PLUS PLC. If the same error occurs again, replace the analog I/O module.
308	X801	IO8 Module Error	Error	The analog I/O module in I/O8 position is not functioning.	Power cycle the CLICK PLUS PLC. If the same error occurs again, replace the analog I/O module.
310	X102	IO1 Missing 24V	Warning	The analog I/O module in I/O1 position is missing external 24VDC input.	Apply 24VDC to the analog I/O module.
311	X103	IO1 CH1 Burnout	Warning	CH1 on the analog I/O module in I/O1 position senses burnout or open circuit.	Check the wiring for CH1. Replace the sensor if it is broken.
312	X106	IO1 CH2 Burnout	Warning	CH2 on the analog I/O module in I/O1 position senses burnout or open circuit.	Check the wiring for CH2. Replace the sensor if it is broken.
313	X109	IO1 CH3 Burnout	Warning	CH3 on the analog I/O module in I/O1 position senses burnout or open circuit.	Check the wiring for CH3. Replace the sensor if it is broken.
314	X112	IO1 CH4 Burnout	Warning	CH4 on the analog I/O module in I/O1 position senses burnout or open circuit.	Check the wiring for CH4. Replace the sensor if it is broken.
320	X202	IO2 Missing 24V	Warning	The analog I/O module in I/O2 position is missing external 24VDC input.	Apply 24VDC to the analog I/O module.

* The Status Flags are turned ON when the related errors occur.

Error code table continued on next page.

Error Codes (continued)

PLC Error Codes					
Error Code	Status Flag*	Error Name	Category	Causes	Solutions
321	X203	IO2 CH1 Burnout	Warning	CH1 on the analog I/O module in I/O2 position senses burnout or open circuit.	Check the wiring for CH1. Replace the sensor if it is broken.
322	X206	IO2 CH2 Burnout	Warning	CH2 on the analog I/O module in I/O2 position senses burnout or open circuit.	Check the wiring for CH2. Replace the sensor if it is broken.
323	X209	IO2 CH3 Burnout	Warning	CH3 on the analog I/O module in I/O2 position senses burnout or open circuit.	Check the wiring for CH3. Replace the sensor if it is broken.
324	X212	IO2 CH4 Burnout	Warning	CH4 on the analog I/O module in I/O2 position senses burnout or open circuit.	Check the wiring for CH4. Replace the sensor if it is broken.
330	X302	IO3 Missing 24V	Warning	The analog I/O module in I/O3 position is missing external 24VDC input.	Apply 24VDC to the analog I/O module.
331	X303	IO3 CH1 Burnout	Warning	CH1 on the analog I/O module in I/O3 position senses burnout or open circuit.	Check the wiring for CH1. Replace the sensor if it is broken.
332	X306	IO3 CH2 Burnout	Warning	CH2 on the analog I/O module in I/O3 position senses burnout or open circuit.	Check the wiring for CH2. Replace the sensor if it is broken.
333	X309	IO3 CH3 Burnout	Warning	CH3 on the analog I/O module in I/O3 position senses burnout or open circuit.	Check the wiring for CH3. Replace the sensor if it is broken.
334	X312	IO3 CH4 Burnout	Warning	CH4 on the analog I/O module in I/O3 position senses burnout or open circuit.	Check the wiring for CH4. Replace the sensor if it is broken.
340	X402	IO4 Missing 24V	Warning	The analog I/O module in I/O4 position is missing external 24VDC input.	Apply 24VDC to the analog I/O module.
341	X403	IO4 CH1 Burnout	Warning	CH1 on the analog I/O module in I/O4 position senses burnout or open circuit.	Check the wiring for CH1. Replace the sensor if it is broken.
342	X406	IO4 CH2 Burnout	Warning	CH2 on the analog I/O module in I/O4 position senses burnout or open circuit.	Check the wiring for CH2. Replace the sensor if it is broken.
343	X409	IO4 CH3 Burnout	Warning	CH3 on the analog I/O module in I/O4 position senses burnout or open circuit.	Check the wiring for CH3. Replace the sensor if it is broken.
344	X412	IO4 CH4 Burnout	Warning	CH4 on the analog I/O module in I/O4 position senses burnout or open circuit.	Check the wiring for CH4. Replace the sensor if it is broken.
350	X502	IO5 Missing 24V	Warning	The analog I/O module in I/O5 position is missing external 24VDC input.	Apply 24VDC to the analog I/O module.

* The Status Flags are turned ON when the related errors occur.

Error code table continued on next page.

Error Codes (continued)

PLC Error Codes					
Error Code	Status Flag*	Error Name	Category	Causes	Solutions
351	X503	I05 CH1 Burnout	Warning	CH1 on the analog I/O module in I/O5 position senses burnout or open circuit.	Check the wiring for CH1. Replace the sensor if it is broken.
352	X506	I05 CH2 Burnout	Warning	CH2 on the analog I/O module in I/O5 position senses burnout or open circuit.	Check the wiring for CH2. Replace the sensor if it is broken.
353	X509	I05 CH3 Burnout	Warning	CH3 on the analog I/O module in I/O5 position senses burnout or open circuit.	Check the wiring for CH3. Replace the sensor if it is broken.
354	X512	I05 CH4 Burnout	Warning	CH4 on the analog I/O module in I/O5 position senses burnout or open circuit.	Check the wiring for CH4. Replace the sensor if it is broken.
360	X602	I06 Missing 24V	Warning	The analog I/O module in I/O6 position is missing external 24VDC input.	Apply 24VDC to the analog I/O module.
361	X603	I06 CH1 Burnout	Warning	CH1 on the analog I/O module in I/O6 position senses burnout or open circuit.	Check the wiring for CH1. Replace the sensor if it is broken.
362	X606	I06 CH2 Burnout	Warning	CH2 on the analog I/O module in I/O6 position senses burnout or open circuit.	Check the wiring for CH2. Replace the sensor if it is broken.
363	X609	I06 CH3 Burnout	Warning	CH3 on the analog I/O module in I/O6 position senses burnout or open circuit.	Check the wiring for CH3. Replace the sensor if it is broken.
364	X612	I06 CH4 Burnout	Warning	CH4 on the analog I/O module in I/O6 position senses burnout or open circuit.	Check the wiring for CH4. Replace the sensor if it is broken.
370	X702	I07 Missing 24V	Warning	The analog I/O module in I/O7 position is missing external 24VDC input.	Apply 24VDC to the analog I/O module.
371	X703	I07 CH1 Burnout	Warning	CH1 on the analog I/O module in I/O7 position senses burnout or open circuit.	Check the wiring for CH1. Replace the sensor if it is broken.
372	X706	I07 CH2 Burnout	Warning	CH2 on the analog I/O module in I/O7 position senses burnout or open circuit.	Check the wiring for CH2. Replace the sensor if it is broken.
373	X709	I07 CH3 Burnout	Warning	CH3 on the analog I/O module in I/O7 position senses burnout or open circuit.	Check the wiring for CH3. Replace the sensor if it is broken.
374	X712	I07 CH4 Burnout	Warning	CH4 on the analog I/O module in I/O7 position senses burnout or open circuit.	Check the wiring for CH4. Replace the sensor if it is broken.
380	X802	I08 Missing 24V	Warning	The analog I/O module in I/O8 position is missing external 24VDC input.	Apply 24VDC to the analog I/O module.

* The Status Flags are turned ON when the related errors occur.

Error code table continued on next page.

Error Codes (continued)

PLC Error Codes					
Error Code	Status Flag*	Error Name	Category	Causes	Solutions
381	X803	IO8 CH1 Burnout	Warning	CH1 on the analog I/O module in I/O8 position senses burnout or open circuit.	Check the wiring for CH1. Replace the sensor if it is broken.
382	X806	IO8 CH2 Burnout	Warning	CH2 on the analog I/O module in I/O8 position senses burnout or open circuit.	Check the wiring for CH2. Replace the sensor if it is broken.
383	X809	IO8 CH3 Burnout	Warning	CH3 on the analog I/O module in I/O8 position senses burnout or open circuit.	Check the wiring for CH3. Replace the sensor if it is broken.
384	X812	IO8 CH4 Burnout	Warning	CH4 on the analog I/O module in I/O8 position senses burnout or open circuit.	Check the wiring for CH4. Replace the sensor if it is broken.

* The Status Flags are turned ON when the related errors occur.

SECURITY CONSIDERATIONS FOR CONTROL SYSTEMS NETWORKS



In This Appendix...

Security Considerations for Control Systems Networks.....A-2

Security Considerations for Control Systems Networks

Manufacturers are realizing that to stay competitive, their Automation and Control Systems need to be more integrated within their plant. The systems often need to be integrated with upstream Enterprise Data Systems, and even further integrated to allow information to be accessible across multiple plants, or even through the Internet. This convergence of the IT world with the Automation World creates challenges in maintaining secure systems and protecting your investments in processes, personnel, data and intellectual property.

While Automation Networks and Systems have built-in password protection schemes, this is only one very small step in securing your systems. Automation Control System Networks need to incorporate data protection and security measures that are at least as robust as a typical business computer system. We recommend that users of PLCs, HMI products and SCADA systems perform your own network security analysis to determine the proper level of security required for your application. However, the Department of Homeland Security's National Cybersecurity and Communications Integration Center (NCCIC) and Industrial Control Systems Cyber Emergency Response Team (ICS-CERT) has provided direction related to network security and safety under an approach described as "Defense in Depth", which is published at https://www.us-cert.gov/sites/default/files/recommended_practices/NCCIC_ICSCERT_Defense_in_Depth_2016_S508C.pdf.

This comprehensive security strategy involves physical protection methods, as well as process and policy methods. This approach creates multiple layers and levels of security for industrial automation systems. Such safeguards include the location of control system networks behind firewalls, their isolation from business networks, the use of intrusion detection systems, and the use of secure methods for remote access such as Virtual Private Networks (VPNs). Further, users should minimize network exposure for all control system devices and such control systems, and these systems should not directly face the internet. Following these procedures should significantly reduce your risks both from external sources as well as internal sources, and provide a more secure system.

It is the user's responsibility to protect such systems, just as you would protect your computer and business systems. AutomationDirect recommends using one or more of these resources in putting together a secure system:

- ICS-CERT's Control Systems recommended practices at the following web address: <https://ics-cert.us-cert.gov/Recommended-Practices>
- Special Publication 800-82 of the National Institute of Standards and Technology – Guide to Industrial Control Systems (ICS) Security: <https://csrc.nist.gov/publications/detail/sp/800-82/rev-2/final>
- ISA99, Industrial Automation and Control Systems Security: <https://www.isa.org/standards-and-publications/isa-standards/isa-standards-committees/isa99> (please note this is a summary and these standards have to be purchased from ISA)

The above set of resources provides a comprehensive approach to securing a control system network and reducing risk and exposure from security breaches. Given the nature of any system that accesses the internet, it is incumbent upon each user to assess the needs and requirements of their application, and take steps to mitigate the particular security risks inherent in their control system.