



**Manual Number: C0-USER-M**

## ⚡ WARNING ⚡

Thank you for purchasing automation equipment from **Automationdirect.com**<sup>®</sup>, doing business as, **AutomationDirect**. We want your new automation equipment to operate safely. Anyone who installs or uses this equipment should read this publication (and any other relevant publications) before installing or operating the equipment.

To minimize the risk of potential safety problems, you should follow all applicable local and national codes that regulate the installation and operation of your equipment. These codes vary from area to area and usually change with time. It is your responsibility to determine which codes should be followed, and to verify that the equipment, installation, and operation is in compliance with the latest revision of these codes.

At a minimum, you should follow all applicable sections of the National Fire Code, National Electrical Code, and the codes of the National Electrical Manufacturer's Association (NEMA). There may be local regulatory or government offices that can also help determine which codes and standards are necessary for safe installation and operation.

Equipment damage or serious injury to personnel can result from the failure to follow all applicable codes and standards. We do not guarantee the products described in this publication are suitable for your particular application, nor do we assume any responsibility for your product design, installation, or operation.

Our products are not fault-tolerant and are not designed, manufactured or intended for use or resale as on-line control equipment in hazardous environments requiring fail-safe performance, such as in the operation of nuclear facilities, aircraft navigation or communication systems, air traffic control, direct life support machines, or weapons systems, in which the failure of the product could lead directly to death, personal injury, or severe physical or environmental damage ("High Risk Activities"). **AutomationDirect** specifically disclaims any expressed or implied warranty of fitness for High Risk Activities.

For additional warranty and safety information, see the Terms and Conditions section of our catalog. If you have any questions concerning the installation or operation of this equipment, or if you need additional information, please call us at 770-844-4200.

This publication is based on information that was available at the time it was printed. At **AutomationDirect** we constantly strive to improve our products and services, so we reserve the right to make changes to the products and/or publications at any time without notice and without any obligation. This publication may also discuss features that may not be available in certain revisions of the product.

## Trademarks

This publication may contain references to products produced and/or offered by other companies. The product and company names may be trademarked and are the sole property of their respective owners. **AutomationDirect** disclaims any proprietary interest in the marks and names of others.

Copyright 2008–2026, **Automationdirect.com**<sup>®</sup> Incorporated  
All Rights Reserved

No part of this manual shall be copied, reproduced, or transmitted in any way without the prior, written consent of **Automationdirect.com**<sup>®</sup> Incorporated. **AutomationDirect** retains the exclusive rights to all information included in this document.

## ⚡ ADVERTENCIA ⚡

Gracias por comprar equipo de automatización de **Automationdirect.com**<sup>®</sup>. Deseamos que su nuevo equipo de automatización opere de manera segura. Cualquier persona que instale o use este equipo debe leer esta publicación (y cualquier otra publicación pertinente) antes de instalar u operar el equipo.

Para reducir al mínimo el riesgo debido a problemas de seguridad, debe seguir todos los códigos de seguridad locales o nacionales aplicables que regulan la instalación y operación de su equipo. Estos códigos varían de área en área y usualmente cambian con el tiempo. Es su responsabilidad determinar cuales códigos deben ser seguidos y verificar que el equipo, instalación y operación estén en cumplimiento con la revisión más reciente de estos códigos.

Como mínimo, debe seguir las secciones aplicables del Código Nacional de Incendio, Código Nacional Eléctrico, y los códigos de (NEMA) la Asociación Nacional de Fabricantes Eléctricos de USA. Puede haber oficinas de normas locales o del gobierno que pueden ayudar a determinar cuales códigos y normas son necesarios para una instalación y operación segura.

Si no se siguen todos los códigos y normas aplicables, puede resultar en daños al equipo o lesiones serias a personas. No garantizamos los productos descritos en esta publicación para ser adecuados para su aplicación en particular, ni asumimos ninguna responsabilidad por el diseño de su producto, la instalación u operación.

Nuestros productos no son tolerantes a fallas y no han sido diseñados, fabricados o intencionados para uso o reventa como equipo de control en línea en ambientes peligrosos que requieren una ejecución sin fallas, tales como operación en instalaciones nucleares, sistemas de navegación aérea, o de comunicación, control de tráfico aéreo, máquinas de soporte de vida o sistemas de armamentos en las cuales la falla del producto puede resultar directamente en muerte, heridas personales, o daños físicos o ambientales severos (“Actividades de Alto Riesgo”). **Automationdirect.com** específicamente rechaza cualquier garantía ya sea expresada o implicada para actividades de alto riesgo.

Para información adicional acerca de garantía e información de seguridad, vea la sección de Términos y Condiciones de nuestro catálogo. Si tiene alguna pregunta sobre instalación u operación de este equipo, o si necesita información adicional, por favor llámenos al número 770-844-4200 en Estados Unidos.

Esta publicación está basada en la información disponible al momento de impresión. En **Automationdirect.com** nos esforzamos constantemente para mejorar nuestros productos y servicios, así que nos reservamos el derecho de hacer cambios al producto y/o a las publicaciones en cualquier momento sin notificación y sin ninguna obligación. Esta publicación también puede discutir características que no estén disponibles en ciertas revisiones del producto.

## Marcas Registradas

Esta publicación puede contener referencias a productos producidos y/u ofrecidos por otras compañías. Los nombres de las compañías y productos pueden tener marcas registradas y son propiedad única de sus respectivos dueños. **Automationdirect.com**, renuncia cualquier interés propietario en las marcas y nombres de otros.

**PROPIEDAD LITERARIA 2008–2026, AUTOMATIONDIRECT.COM<sup>®</sup> INCORPORATED**  
Todos los derechos reservados

No se permite copiar, reproducir, o transmitir de ninguna forma ninguna parte de este manual sin previo consentimiento por escrito de **Automationdirect.com<sup>®</sup> Incorporated**. **Automationdirect.com** retiene los derechos exclusivos a toda la información incluida en este documento. Los usuarios de este equipo pueden copiar este documento solamente para instalar, configurar y mantener el equipo correspondiente. También las instituciones de enseñanza pueden usar este manual para propósitos educativos.

## ⚡ AVERTISSEMENT ⚡

Nous vous remercions d'avoir acheté l'équipement d'automatisation de **Automationdirect.com**®, en faisant des affaires comme, **AutomationDirect**. Nous tenons à ce que votre nouvel équipement d'automatisation fonctionne en toute sécurité. Toute personne qui installe ou utilise cet équipement doit lire la présente publication (et toutes les autres publications pertinentes) avant de l'installer ou de l'utiliser.

Afin de réduire au minimum le risque d'éventuels problèmes de sécurité, vous devez respecter tous les codes locaux et nationaux applicables régissant l'installation et le fonctionnement de votre équipement. Ces codes diffèrent d'une région à l'autre et, habituellement, évoluent au fil du temps. Il vous incombe de déterminer les codes à respecter et de vous assurer que l'équipement, l'installation et le fonctionnement sont conformes aux exigences de la version la plus récente de ces codes.

Vous devez, à tout le moins, respecter toutes les sections applicables du Code national de prévention des incendies, du Code national de l'électricité et des codes de la National Electrical Manufacturer's Association (NEMA). Des organismes de réglementation ou des services gouvernementaux locaux peuvent également vous aider à déterminer les codes ainsi que les normes à respecter pour assurer une installation et un fonctionnement sûrs.

L'omission de respecter la totalité des codes et des normes applicables peut entraîner des dommages à l'équipement ou causer de graves blessures au personnel. Nous ne garantissons pas que les produits décrits dans cette publication conviennent à votre application particulière et nous n'assumons aucune responsabilité à l'égard de la conception, de l'installation ou du fonctionnement de votre produit.

Nos produits ne sont pas insensibles aux défaillances et ne sont ni conçus ni fabriqués pour l'utilisation ou la revente en tant qu'équipement de commande en ligne dans des environnements dangereux nécessitant une sécurité absolue, par exemple, l'exploitation d'installations nucléaires, les systèmes de navigation aérienne ou de communication, le contrôle de la circulation aérienne, les équipements de survie ou les systèmes d'armes, pour lesquels la défaillance du produit peut provoquer la mort, des blessures corporelles ou de graves dommages matériels ou environnementaux («activités à risque élevé»). La société **AutomationDirect** nie toute garantie expresse ou implicite d'aptitude à l'emploi en ce qui a trait aux activités à risque élevé.

Pour des renseignements additionnels touchant la garantie et la sécurité, veuillez consulter la section Modalités et conditions de notre documentation. Si vous avez des questions au sujet de l'installation ou du fonctionnement de cet équipement, ou encore si vous avez besoin de renseignements supplémentaires, n'hésitez pas à nous téléphoner au 770-844-4200.

Cette publication s'appuie sur l'information qui était disponible au moment de l'impression. À la société **AutomationDirect**, nous nous efforçons constamment d'améliorer nos produits et services. C'est pourquoi nous nous réservons le droit d'apporter des modifications aux produits ou aux publications en tout temps, sans préavis ni quelque obligation que ce soit. La présente publication peut aussi porter sur des caractéristiques susceptibles de ne pas être offertes dans certaines versions révisées du produit.

## Marques de commerce

La présente publication peut contenir des références à des produits fabriqués ou offerts par d'autres entreprises. Les désignations des produits et des entreprises peuvent être des marques de commerce et appartiennent exclusivement à leurs propriétaires respectifs. **AutomationDirect** nie tout intérêt dans les autres marques et désignations.

Copyright 2008–2026, **Automationdirect.com**® Incorporated  
Tous droits réservés

Nulle partie de ce manuel ne doit être copiée, reproduite ou transmise de quelque façon que ce soit sans le consentement préalable écrit de la société **Automationdirect.com**® Incorporated. **AutomationDirect** conserve les droits exclusifs à l'égard de tous les renseignements contenus dans le présent document.

# CLICK PLC User Manual



Please include the Manual Number and the Manual Issue, both shown below, when communicating with Technical Support regarding this publication.

Manual Number: C0-USER-M  
 Issue: 6th Edition, Rev. Q  
 Issue Date: 06/2026

Publication History		
Issue	Date	Description of Changes
1st Edition	5/08	Original
Rev. A	10/08	Updated specifications and drawings throughout manual.
2nd Edition	5/09	Added Port 3 and C0-02DD1-D, C0-02DD2-D, C0-02DR-D analog CPU units.
Rev. A	8/09	Updated wiring diagram for C0-02DR-D CPU module.
3rd Edition	10/10	Added four Standard CPUs and C0-08NE3 and C0-16NE3 24VAC input modules
Rev. A	11/10	Revised current consumption specification for Standard and Analog CPUs.
4th Edition	6/13	Added 11 I/O modules: 3 discrete combo, 4 analog in, 2 analog out, 2 analog combo.
Rev. A	10/13	Added 11 I/O modules: 3 discrete combo, 4 analog in, 2 analog out, 2 analog combo.
5th Edition	12/15	Added eight CLICK PLC units with built-in Ethernet
Rev. A	4/17	Added Interlocking examples to Chapter 4, software and firmware updates, and other misc. minor corrections.
6th Edition	11/17	Added twelve CLICK Ethernet Analog PLC units.
Rev. A	10/03/18	Added detailed information on high-speed operations and configurations.
Rev. B	10/18/18	Updated high-speed module specifications.
Rev. C	4/10/19	Added EtherNet/IP Implicit and Explicit (adapter server) in S/W
Rev. D	5/2/19	ZIPLink modules ZL-LTB16-24 and ZL-LTB32-24 have been obsolete and replaced by ZL-LTB16-24-1 and ZL-LTB32-24-1 respectively.
Rev. E	7/11/19	Added Error 108 to Error Table page 6-12.
Rev. F	9/18/19	Added CLICK PID features.
Rev. G	2/20	Added specs for C0-08SIM, C0-04TRS-10, C0-08TR-3, and terminal block C0-8TB-1. Added network security notice as Appendix A.
Rev. H	3/21	Clarified descriptions of XD and YD registers on page 2-16.
Rev. I	9/21	Removed varistors from drawings of the internal circuits on Relay Output CPUs.
Rev. J	10/21	Clarified lack of Power LED indicator on analog I/O modules.
Rev. K	11/22	Updated copyright.
Rev. L	12/22	Added "Silent Install" feature. Removed Type 1 Fonts.
Rev. M	4/23	Changed references to CLICK software media from CD to USB.
Rev. N	5/24	Clarified current limitations on relay outputs when using ZIPLink wiring system.
Rev. O	2/25	Added C0-04POT module.
Rev. P	5/26	Updated firmware requirements for C0-02DD1-D, C0-02DD2-D, C0-02DR-D.
Rev. Q	6/26	Clarified firmware requirements for C0-02DD1-D, C0-02DD2-D, C0-02DR-D.

# TABLE OF CONTENTS

---



## Publication History

## Table of Contents

### Chapter 1 - Getting Started

Introduction.....	1-2
Conventions Used.....	1-3
Before you begin.....	1-4
Step 1: Install Programming Software.....	1-5
Step 2: Launch Programming Software .....	1-6
Step 3: Create a Project.....	1-8
Step 4: Compile and Save Project.....	1-14
Step 5: Apply Power .....	1-15
Step 6: Establish PC to PLC Communications.....	1-16
Step 7: Write Project into PLC.....	1-24
Step 8: Place PLC in RUN Mode .....	1-25
Step 9: Test Project using Data View Monitor .....	1-26
Step 10: Y001 Output On?.....	1-27
Additional Training Resources .....	1-28

### Chapter 2 - Specifications

Overview of PLC System .....	2-2
PLC Units .....	2-3
Basic PLC Units .....	2-3
Built-in I/O (Basic PLC Units) .....	2-3

## Table of Contents

---

Standard PLC Units.....	2-4
Built-in I/O (Standard PLC Units) .....	2-4
Analog PLC Units.....	2-5
Built-in I/O (Analog PLC Units) .....	2-5
Ethernet Basic PLC Units.....	2-6
Built-in I/O (Ethernet Basic PLC Units) .....	2-6
Ethernet Standard PLC Units .....	2-7
Built-in I/O (Ethernet Standard PLC Units) .....	2-7
Ethernet Analog PLC Units .....	2-8
Built-in I/O (Ethernet Analog PLC units) .....	2-8
Communication Ports .....	2-9
Memory .....	2-9
<b>I/O Modules .....</b>	<b>2-10</b>
Power Supply .....	2-13
<b>Programming Software .....</b>	<b>2-14</b>
PC Requirements.....	2-14
<b>Data Types, Memory, and Numbering System .....</b>	<b>2-15</b>
Data Types .....	2-15
Memory Types.....	2-16
I/O Numbering System .....	2-18
<b>PLC Operation.....</b>	<b>2-19</b>
Introduction.....	2-19
PLC Operating System.....	2-19
PLC Operating Modes.....	2-20
Stop Mode .....	2-20
Run Mode .....	2-20
Read Inputs .....	2-21
Service Peripherals and Force I/O .....	2-21
Update System Control (SC) Relays and System Data (SD) Registers .....	2-22
Solve Application Program .....	2-22
Write Outputs .....	2-22
Diagnostics .....	2-22
<b>Power Budgeting.....</b>	<b>2-23</b>
What is Power Budgeting? .....	2-23
Power Budget Calculation.....	2-24

Power Budget Example .....	2-25
Power Budgeting using the CLICK Programming Software .....	2-25
General Specifications .....	2-26
General Specifications (all CLICK PLC units) .....	2-26
PLC Unit Specifications .....	2-27
Common Specifications .....	2-27
PLC LED Status Indicators.....	2-29
Memory Map .....	2-32
<b>CLICK PLC Hardware/Software Compatibility .....</b>	<b>2-34</b>
Basic PLC Unit Specifications .....	2-36
C0-00DD1-D – 8 DC Input/6 Sinking DC Output Micro PLC.....	2-36
C0-00DD2-D – 8 DC Input/6 Sourcing DC Output Micro PLC .....	2-38
C0-00DR-D – 8 DC Input/6 Relay Output Micro PLC .....	2-40
C0-00AR-D – 8 AC Input/6 Relay Output Micro PLC .....	2-42
Standard PLC Unit Specifications.....	2-44
C0-01DD1-D – 8 DC Input/6 Sinking DC Output Micro PLC.....	2-44
C0-01DD2-D – 8 DC Input/6 Sourcing DC Output Micro PLC .....	2-46
C0-01DR-D – 8 DC Input/6 Relay Output Micro PLC.....	2-48
C0-01AR-D – 8 AC Input/6 Relay Output Micro PLC .....	2-50
Analog PLC Unit Specifications.....	2-52
C0-02DD1-D – 4 DC Input/4 Sinking DC Output; 2 Analog In/2 Analog Out Micro PLC.....	2-52
C0-02DD2-D – 4 DC Input/4 Sourcing DC Output; 2 Analog In/2 Analog Out Micro PLC.....	2-55
C0-02DR-D – 4 DC Input/4 Relay Output; 2 Analog In/2 Analog Out Micro PLC .....	2-58
Ethernet Basic PLC Unit Specifications .....	2-61
C0-10DD1E-D – 8 DC Input/6 Sinking DC Output Micro PLC .....	2-61
C0-10DD2E-D – 8 DC Input/6 Sourcing DC Output Micro PLC.....	2-63
C0-10DRE-D – 8 DC Input/6 Relay Output Micro PLC .....	2-65
C0-10ARE-D – 8 AC Input/6 Relay Output Micro PLC.....	2-67
Ethernet Standard PLC Unit Specifications.....	2-69
C0-11DD1E-D – 8 DC Input/6 Sinking DC Output Micro PLC.....	2-69
C0-11DD2E-D – 8 DC Input/6 Sourcing DC Output Micro PLC.....	2-71

## Table of Contents

---

C0-11DRE-D – 8 DC Input/6 Relay Output Micro PLC .....	2-73
C0-11ARE-D – 8 AC Input/6 Relay Output Micro PLC.....	2-75
Ethernet Analog PLC Unit Specifications .....	2-77
C0-12DD1E-D – 4 DC Input (Sink/Source)/4 Sinking DC Output .....	2-77
2 Analog Voltage/Current Input	
2 Analog Voltage/Current Output Micro PLC .....	2-77
C0-12DD2E-D – 4 DC Input (Sink/Source)/4 Sourcing DC Output; .....	2-80
2 Analog Voltage/Current Input	
2 Analog Voltage/Current Output Micro PLC .....	2-80
C0-12DRE-D – 4 DC Input (Sink/Source)/4 Relay Output; .....	2-83
2 Analog Voltage/Current Input	
2 Analog Voltage/Current Output Micro PLC .....	2-83
C0-12ARE-D – 4 AC Input/4 Relay Output; .....	2-86
2 Analog Voltage/Current Input	
2 Analog Voltage/Current Output Micro PLC .....	2-86
C0-12DD1E-1-D – 4 DC Input (Sink/Source)/4 Sinking DC Output; .....	2-89
4 Analog Current Input	
2 Analog Current Output Micro PLC.....	2-89
C0-12DD2E-1-D – 4 DC Input (Sink/Source)/4 Sourcing DC Output; .....	2-92
4 Analog Current Input	
2 Analog Current Output Micro PLC.....	2-92
C0-12DRE-1-D – 4 DC Input (Sink/Source)/4 Relay Output; .....	2-95
4 Analog Current Input	
2 Analog Current Output Micro PLC.....	2-95
C0-12ARE-1-D – 4 AC Input/4 Relay Output; .....	2-98
4 Analog Current Input	
2 Analog Current Output Micro PLC.....	2-98
C0-12DD1E-2-D – 4 DC Input (Sink/Source)/4 Sinking DC Output; .....	2-101
4 Analog Voltage Input	
2 Analog Voltage Output Micro PLC.....	2-101
C0-12DD2E-2-D – 4 DC Input (Sink/Source)/4 Sourcing DC Output; .....	2-104
4 Analog Voltage Input	
2 Analog Voltage Output Micro PLC.....	2-104
C0-12DRE-2-D – 4 DC Input (Sink/Source)/4 Relay Output; .....	2-107
4 Analog Voltage Input	
2 Analog Voltage Output Micro PLC.....	2-107
C0-12ARE-2-D – 4 AC Input (Sink/Source) /4 Relay Output; .....	2-110

4 Analog Voltage Input	
2 Analog Voltage Output Micro PLC.....	2-110
I/O Module Specifications.....	2-113
I/O Terminal Block Specifications for CPUs and I/O Modules.....	2-113
LED Indicators.....	2-114
C0-08SIM – 8-Point Toggle Switch Input Module.....	2-115
C0-04POT – 4-Point Potentiometer Input Module.....	2-116
C0-08ND3 – 8-Point Sink/Source DC Input Module.....	2-117
C0-08ND3-1 – 8-Point Sink/Source DC Input Module.....	2-118
C0-16ND3 – 16-Point Sink/Source DC Input Module.....	2-119
C0-08NE3 – 8-Point Sink/Source AC/DC Input Module.....	2-120
C0-16NE3 – 16-Point Sink/Source AC/DC Input Module.....	2-121
C0-08NA – 8-Point AC Input Module.....	2-122
C0-08TD1 – 8-Point Sinking DC Output Module.....	2-123
C0-08TD2 – 8-Point Sourcing DC Output Module.....	2-124
C0-16TD1 – 16-Point Sinking DC Output Module.....	2-125
C0-16TD2 – 16-Point Sourcing Output Module.....	2-126
C0-08TA – 8-Point AC Output Module.....	2-127
C0-04TRS – 4-Point Relay Output Module.....	2-128
C0-04TRS-10 – 4-Point Relay Output Module.....	2-129
C0-08TR – 8-Point Relay Output Module.....	2-130
C0-08TR-3 – 8-Point Relay Output Module.....	2-131
C0-16CDD1 – 8-Point DC Input and 8-Point DC Sinking Output Module.....	2-132
C0-16CDD2 – 8-Point DC Input and 8-Point DC Sourcing Output Module.....	2-134
C0-08CDR – 4-Point DC Input and 4-Point Relay Output Module.....	2-136
C0-04AD-1 – 4-Channel Analog Current Input Module.....	2-138
C0-04AD-2 – 4-Channel Analog Voltage Input Module.....	2-139
C0-04RTD – 4-Channel RTD Input Module.....	2-140
C0-04THM – 4-Channel Thermocouple Input Module.....	2-142
C0-04DA-1 – 4-Channel Analog Current Output Module.....	2-144
C0-04DA-2 – 4-Channel Analog Voltage Output Module.....	2-145
C0-4AD2DA-1 – 4-Channel Analog Current Input and 2-Channel Analog Current Output Module.....	2-146
C0-4AD2DA-2 – 4-Channel Analog Voltage Input and 2-Channel Analog Voltage Output Module.....	2-148
Power Supply Specifications.....	2-150

C0-00AC Power Supply.....	2-150
C0-01AC Power Supply.....	2-150
PSP24-DC12-1 DC-DC Converter .....	2-150
Accessories .....	2-151

### Chapter 3 - Installation and Wiring

Safety Guidelines.....	3-2
Plan for Safety.....	3-2
Three Levels of Protection .....	3-3
Orderly System Shutdown.....	3-3
System Power Disconnect.....	3-3
Emergency Stop Circuits.....	3-4
Introduction to the CLICK PLC Mechanical Design .....	3-5
CLICK PLC Units .....	3-5
Component Locations on Basic and Standard PLC Units.....	3-5
Component Locations on Analog PLC Units.....	3-6
Component Locations on Ethernet PLC Units.....	3-7
CLICK I/O Modules.....	3-8
CLICK Power Supplies.....	3-9
Battery Backup (Standard, Analog and Ethernet PLC Units).....	3-10
Mounting Guidelines .....	3-11
Environmental Specifications.....	3-11
Agency Approvals.....	3-11
CLICK Unit Dimensions.....	3-11
Enclosures .....	3-15
Panel Layout and Clearances .....	3-15
Installing the CLICK PLC.....	3-17
Connecting the Modules Together .....	3-17
Mounting CLICK PLC System on DIN Rail .....	3-18
Optional Mounting Method.....	3-18
Wiring Guidelines.....	3-19
Power Input Wiring to Click Power Supply .....	3-19
Power Input Wiring to CLICK PLC .....	3-19

Fuse Protection..... 3–20

Planning the I/O Wiring Routes ..... 3–21

Wiring I/O Modules ..... 3–22

ZIPLink Wiring System Compatibility Matrix for CLICK PLCs ..... 3–23

I/O Wiring Checklist ..... 3–26

System Wiring Strategies ..... 3–27

    PLC Isolation Boundaries ..... 3–27

    Powering I/O Circuits ..... 3–28

    Sinking/Sourcing Concepts ..... 3–29

    I/O “Common Terminal” Concepts ..... 3–30

    DC Input Wiring Methods ..... 3–31

    DC Output Wiring Methods ..... 3–31

    Relay Outputs - Wiring Methods..... 3–33

    Relay Outputs – Transient Suppression for Inductive Loads  
        in a Control System ..... 3–34

Analog I/O Configuration ..... 3–38

    Terminal Block Wiring - Analog PLC Units..... 3–38

    Terminal Block Wiring - Expansion Analog I/O Modules ..... 3–40

    Configuration in the CLICK Programming Software ..... 3–41

    Analog PLC units ..... 3–41

    Analog I/O Modules ..... 3–42

    Analog I/O Monitoring..... 3–44

High-Speed Input Configuration ..... 3–45

    Wiring Examples High Speed Inputs..... 3–47

    3-Wire Sensors..... 3–47

## Chapter 4 - PLC Communications

Introduction..... 4–2

PLC Communication Ports Specifications ..... 4–3

LED Status Indicators..... 4–5

    LED Status Indicators..... 4–5

    DirectLogic Devices That Do Not Work With CLICK PLCs ..... 4–5

3 Steps to Using the CLICK PLC Communications ..... 4–7

Typical Communication Applications ..... 4–8

## Table of Contents

---

Port 1 (RS-232) – Modbus RTU Slave Mode Only .....	4-8
Port 1 (Ethernet) – Modbus TCP .....	4-9
Port 2 (RS-232) – Modbus RTU or ASCII .....	4-10
Port 3 (RS-485 – Modbus RTU or ASCII) .....	4-11
W-1: Com Port 1 & 2 (RS-232) Wiring .....	4-12
W-2: Com Port 1 (Ethernet) Wiring .....	4-17
W-3: Com Port 3 Wiring .....	4-19
C-1: Com Port 1 (RS-232) Setup .....	4-20
C-2: Com Port 1 (Ethernet) Setup .....	4-21
C-3: Com Port 2 Setup (Modbus RTU) .....	4-22
C-4: Com Port 2 Setup (ASCII) .....	4-23
C-5: Com Port 3 Setup (Modbus RTU) .....	4-24
C-6: Com Port 3 Setup (ASCII) .....	4-25
P-1: Modbus Slave (Server) Programming .....	4-26
P-2: Modbus Master Programming (Modbus RTU) .....	4-29
P-3: Modbus Client (Modbus TCP) Programming .....	4-34
P-4: ASCII Receive Programming .....	4-40
P-5: ASCII Send Programming .....	4-43

## Chapter 5 - Maintenance

PLC Maintenance .....	5-2
Check LED Indicators .....	5-2
Project Backup .....	5-2
Check Operating Environment .....	5-2
Check Operating Voltage .....	5-2
Check Physical Condition .....	5-3
Check Project Functionality .....	5-3
Check the PLC Program from CLICK PLC Programming Software .....	5-3

## Chapter 6 - Troubleshooting

Troubleshooting Direction .....	6-2
PLC unit Troubleshooting .....	6-3

Toggle Switch.....6-3

LED Indicators .....6-4

Power Supply Troubleshooting.....6-5

    The input voltage measures less than 20VDC .....6-5

    The input voltage measures greater than 28VDC .....6-5

    How to check the power budget .....6-5

I/O Module Troubleshooting .....6-6

    Input Module Troubleshooting .....6-6

    Output Module Troubleshooting.....6-7

    How to Check the I/O Configuration .....6-7

    How to Check the I/O Status.....6-8

    Replacement of I/O modules.....6-9

Troubleshooting Electrical Noise Problems..... 6-10

    Electrical Noise Problems .....6-10

    Reducing Electrical Noise ..... 6-10

Error Codes..... 6-11

**Appendix A - Security Considerations for Control Systems Networks**

Security Considerations for Control Systems Networks..... A-2

# GETTING STARTED

---



# CHAPTER 1

## In This Chapter...

Introduction .....	1-2
Conventions Used.....	1-3
Before you begin.....	1-4
Step 1: Install Programming Software.....	1-5
Step 2: Launch Programming Software .....	1-6
Step 3: Create a Project .....	1-8
Step 4: Compile and Save Project.....	1-14
Step 5: Apply Power .....	1-15
Step 6: Establish PC to PLC Communications.....	1-16
Step 7: Write Project into PLC.....	1-24
Step 8: Place PLC in RUN Mode .....	1-25
Step 9: Test Project using Data View Monitor .....	1-26
Step 10: Y001 Output On?.....	1-27
Additional Training Resources .....	1-28

# Introduction

### Purpose of this Manual

Thank you for purchasing the AutomationDirect CLICK PLC family of products. This hardware user manual provides information that will help you install, set up, program, troubleshoot, and maintain your CLICK PLC system. The manual includes information that is critical to the safety of the personnel who will install and use the PLC, and to the machinery, processes, and equipment controlled by the PLC.

The manual also includes important information about power and signal wiring, mounting of the PLC, and configuring the PLC system.

### About Getting Started

If you are familiar with PLCs in general, then following the simple steps in this first chapter may be all you require to start being productive using a CLICK PLC system. After you have completed the steps, your CLICK PLC will be running the ladder logic project that you programmed. If you are new to the world of PLCs, be sure to read through all of the chapters in this hardware user manual.

### Supplemental Manuals and Other Help

The CLICK Programming Software, C0-PGMSW, can be downloaded free from the AutomationDirect web site (link shown below under Technical Support). Both this Hardware User Manual, *C0-USER-M*, and the *Software Installation Guide* are free as a download. **The CLICK Programming Software includes searchable online help topics covering all aspects of the software and instruction set.**

### Technical Support

We strive to make our manuals the best in the industry. We rely on your feedback to let us know if we are reaching our goal. If you cannot find the solution to your particular application, or, if for any reason you need technical assistance, please call us at:

**770-844-4200**

Our technical support group will work with you to answer your questions. They are available Monday through Friday from 9:00 A.M. to 6:00 P.M. Eastern Time. We also encourage you to visit our web site where you can find technical and non-technical information about our products and our company.

**<http://www.automationdirect.com>**

## Conventions Used



**WARNING:** When you see the exclamation point icon in the left-hand margin, the paragraph to its immediate right will be a warning. This information could prevent injury, loss of property, or even death in extreme cases. Any warning in this manual should be regarded as critical information that should be read in its entirety. The word **WARNING:** in boldface will mark the beginning of the text.



**NOTE:** When you see the notepad icon in the left-hand margin, the paragraph to its immediate right will be a special note. Notes represent information that may make your work quicker or more efficient. The word **NOTE:** in boldface will mark the beginning of the text.



**TIP:** Whenever the "light bulb" is shown in the left-hand margin, the paragraph to its immediate right will provide a special tip. The word **TIP:** in boldface will mark the beginning of the text.

### Key Topics for Each Chapter

The beginning of each chapter will list the key topics that can be found in that chapter.

<b>Getting Started!</b>		<b>CHAPTER 1</b>
<b>In This Chapter...</b>		
Introduction .....		1-2
Purpose of this Manual .....		1-2
About Getting Started.....		1-2
Supplemental Manuals and Other Help.....		1-2
Technical Support.....		1-2
Conventions Used .....		1-3

## Before you begin...

It is recommended that the following items be available to make this short step-by-step introduction to the CLICK PLC go smoothly.

CLICK PLC unit



CLICK 24VDC Power Supply  
C0-00AC or C0-01AC



Other 24VDC Power Supply  
Example: PSP24-60S



or

PC Running  
Windows



Not available from ADC.

CLICK  
Programming Software  
C0-PGMSW



USB or Free download @  
[http://support.automationdirect.com/  
products/clickplcs.html](http://support.automationdirect.com/products/clickplcs.html)

Based on your CLICK PLC,  
One of the cables shown below:



Ethernet Cat5 Cable

PC with USB port to  
Panel Programming  
Cable Assembly  
EA-MG-PGM-CBL



Screwdriver  
TW-SD-MSL-2



Wire Strippers  
DN-WS



Hookup Wire



AC Power Cord



Not available from ADC.

PC Programming Cable  
D2-DSCBL



PC requires RS-232 port.

## Step 1: Install Programming Software

1. If you have the programming software on USB, insert the USB stick into a USB slot and follow the instructions. Otherwise, download the free CLICK Programming Software, C0-PGMSW, from the following Automationdirect.com web site:  
<http://support.automationdirect.com/products/clickplcs.html>
2. Unzip the downloaded ZIP file.
3. Double click Install.exe. The CLICK PLC Programming Software splash screen should appear after a short time.
4. Click on the splash screen's Install Software button and follow the dialog boxes.
5. If you intend to communicate via USB ports on your personal computer using cable EA-MG-PGM-CBL, click on the Install USB Drive button. Follow the dialog boxes. You can install the USB driver either before or after the software is installed.

### Silent Install

The silent install feature allows the software to be installed from the Windows command line or deployment management software without further user interaction.

Command for Silent Install: **CLICK\_Setup.exe -s**

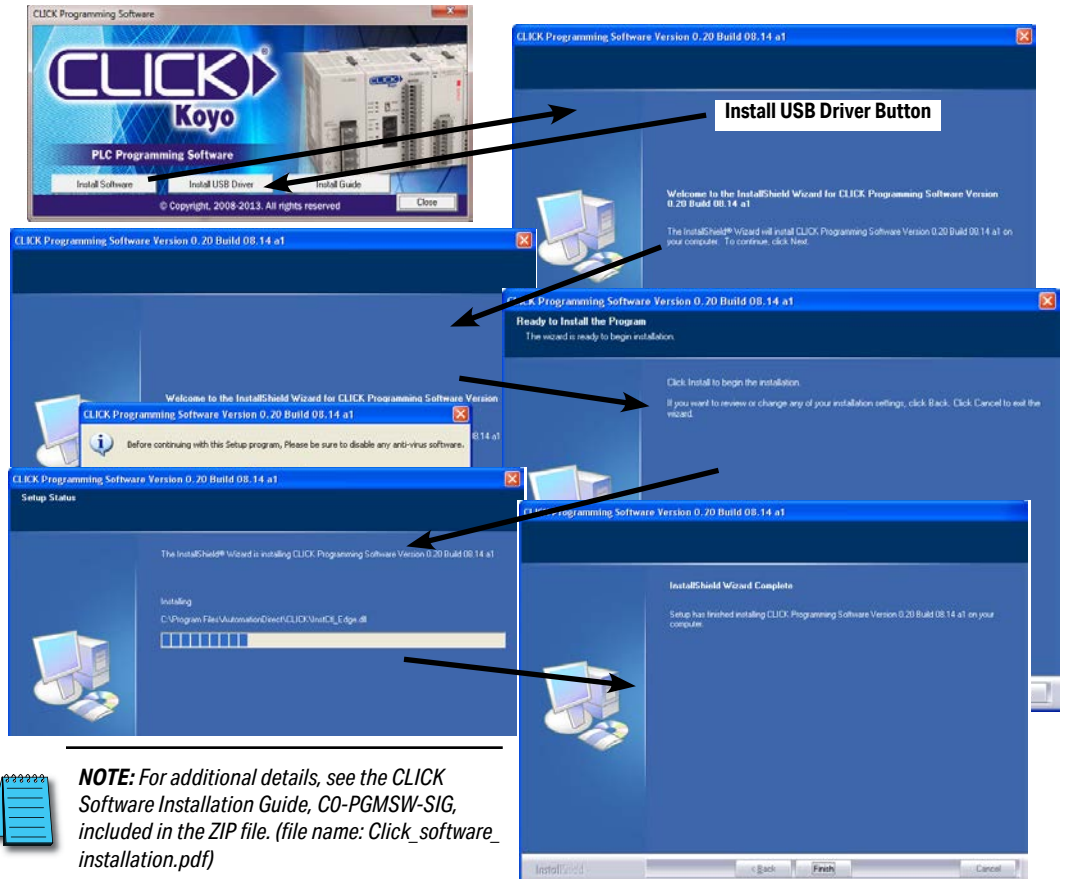

**NOTE:** For additional details, see the *CLICK Software Installation Guide, C0-PGMSW-SIG*, included in the ZIP file. (file name: *Click\_software\_installation.pdf*)

## Step 2: Launch Programming Software

After installing the CLICK Programming Software, C0-PGMSW, choose one of three methods to launch the software. Double click the desktop CLICK icon or, from the PC's Start menu, slide the mouse pointer through the menus (Start > All Programs > AutomationDirect > CLICK Ver 2.50 > CLICK Programming Software) and click the CLICK Programming Software selection or, simply click the icon on the Quick Launch bar. See examples below.

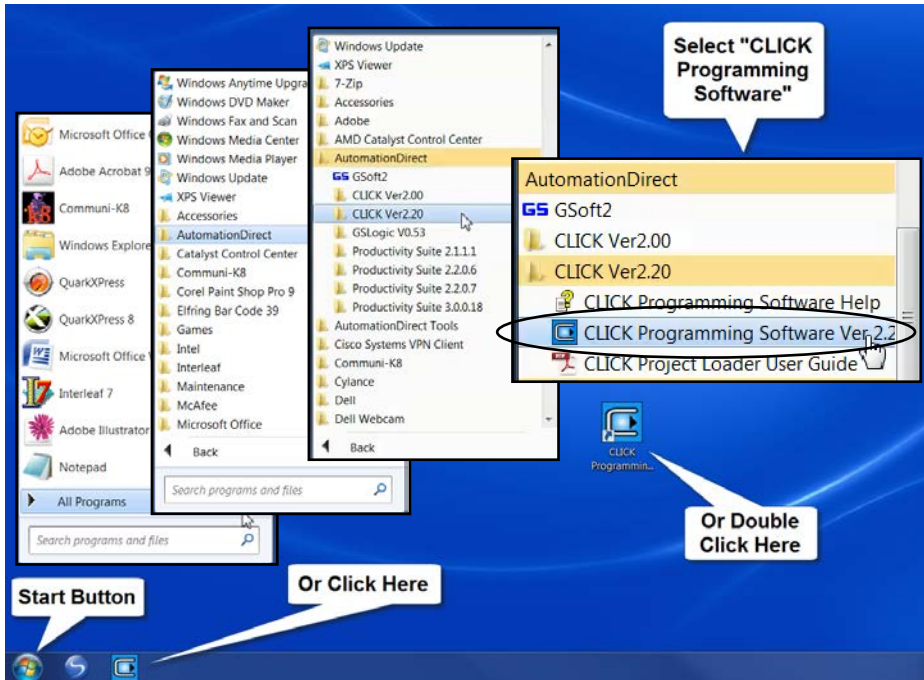

CLICK Programming Software will start up and display the Main Window as shown on the next page.



**NOTE:** The recommended minimum screen size for the CLICK Programming Software is 1024 X 786 pixels.

## Step 2: Launch Programming Software (cont'd)

The Main Window is divided into Menus, Toolbars, and Windows that work together to make project development as simple as possible. See the software's online help for additional details.

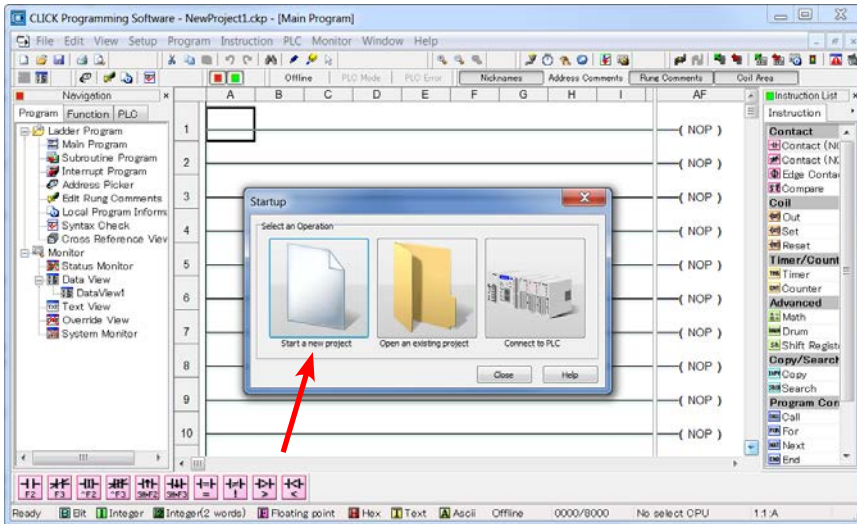

Click on the “Start a new project” graphic in the Startup dialog box. The Select a CPU Module window opens.

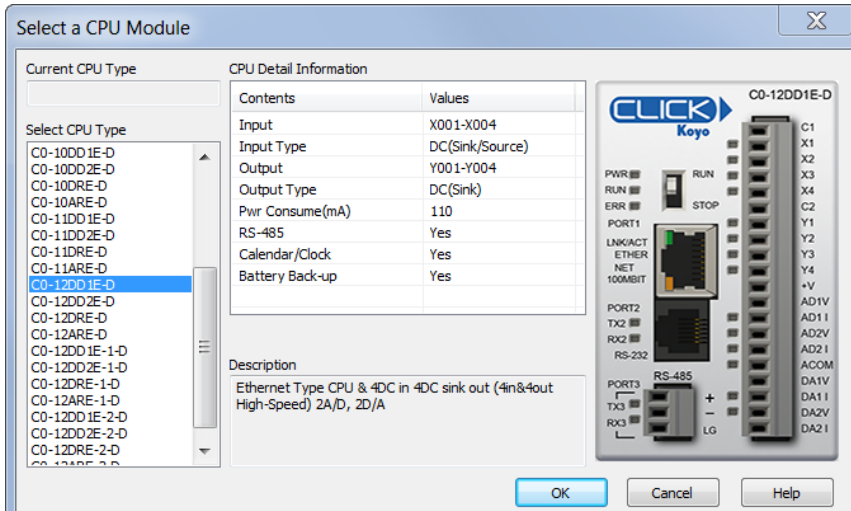

Select from the list on the left for the CLICK PLC unit that you will use for the ladder logic example that follows.

## Step 3: Create a Project

In this step, the project shown below is created by entering the ladder logic program in the order that follows.

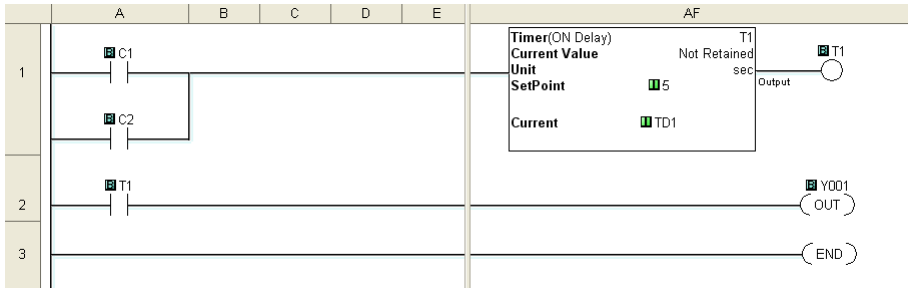

### Rung #1

Place the Box Cursor on the first position on Rung #1, as shown below. From the Instruction List, click & drag a Contact (NO) into this box. Enter C1 into the Bit Memory Address text box of the Contact Normally Open dialog box that pops up and click OK.

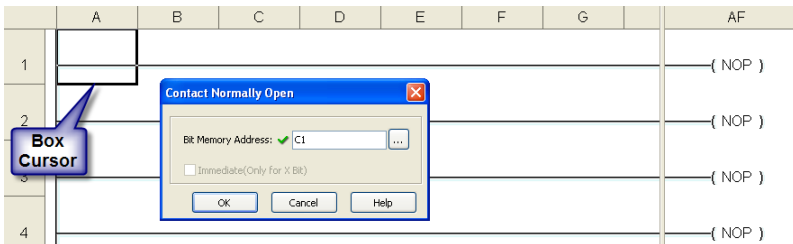

A normally open contact labeled C1 will be placed in the beginning of Rung #1.

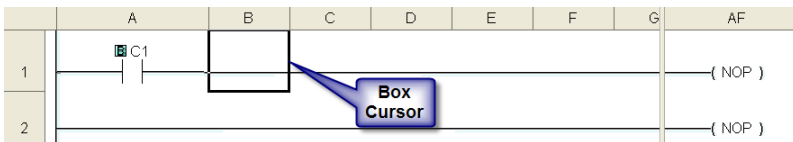

The Box Cursor will move to the next available location.

**Proceed to the next page to continue construction of Rung #1.**

### Step 3: Create a Project (cont'd)

#### Rung #1 (cont'd)

The Line creation tool is used to add a normally open contact in parallel with the C1 contact. Click on the Line creation tool icon located on the Edit toolbar. A blue line will appear, showing the direction of the new line. The Line pen is used to redirect the new line.

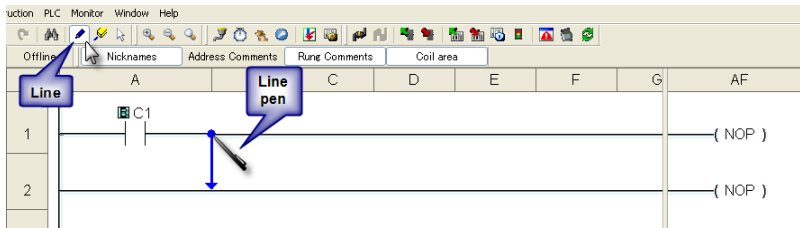

Move the mouse pointer to the end of the new line (arrow) until the mouse pointer becomes a hand with a pointing index finger. Click on the line's arrow.

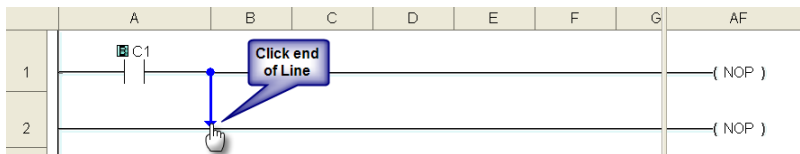

Additional new lines are shown in blue. Move the mouse pointer to the end of the new line that extends to the left and click.

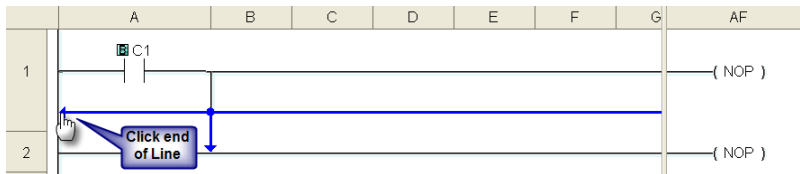

There is now a parallel path around the C1 contact that was first entered as shown here.

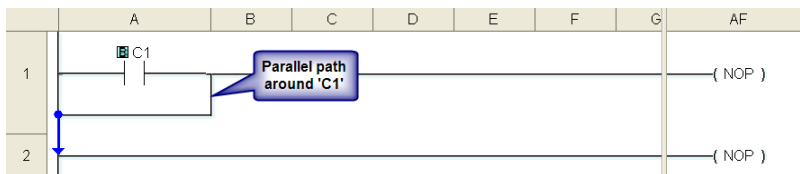

Proceed to the next page to continue construction of Rung #1.

### Step 3: Create a Project (cont'd)

#### Rung #1 (cont'd)

Next, click on the **Reset Line Mode** icon located on the Edit toolbar (Esc key has the same function as the **Reset Line Mode**). The Box Cursor will move to the newly created path. If not, position the Box Cursor over the new path to get ready for the next instruction.

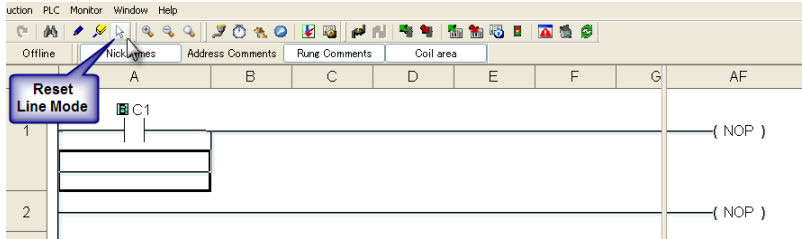

**NOTE:** There is also a **Line Erase** tool icon next to the **Line** tool icon on the Edit toolbar that is used to erase any of the lines that were created using the **Line** tool. Also, to exit the **Line** or **Line Erase** function, click on the **Reset Line Mode** icon on the Edit toolbar. All of the **Line** type tools are also available under the **Edit** drop down menu.



**NOTE:** Lines to form parallel paths in the ladder logic can also be created with the use of the cursor keys in conjunction with the **CTRL** key on the PC's keyboard.

**Proceed to the next page to continue construction of Rung #1.**

### Step 3: Create a Project (cont'd)

#### Rung #1 (cont'd)

From the Instruction List, click & drag a Contact (NO) into the Box Cursor. Enter C2 into the Bit Memory Address text box of the Contact Normally Open dialog box that pops up and click OK. A normally open contact labeled C2 will be placed in parallel with the C1 contact.

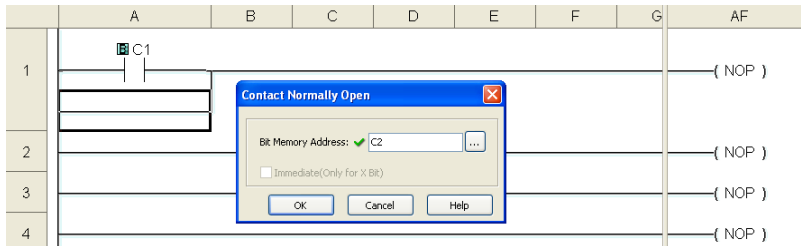

Next, place the Box Cursor on the NOP coil at the far right of Rung #1. NOP stands for No Operation and is a place holder in the ladder logic Coil Area. Click & drag a Timer from the Instruction List into this location. Within the Timer dialog box, enter T1 into the Timer Number text box, the value 5 into the Set Point, and select sec for the timing Unit. The Timer dialog box shows a Timing Chart that graphically represents the function of the ON Delay Timer, and also shows a selection for an alternative OFF Delay Timer mode of operation.

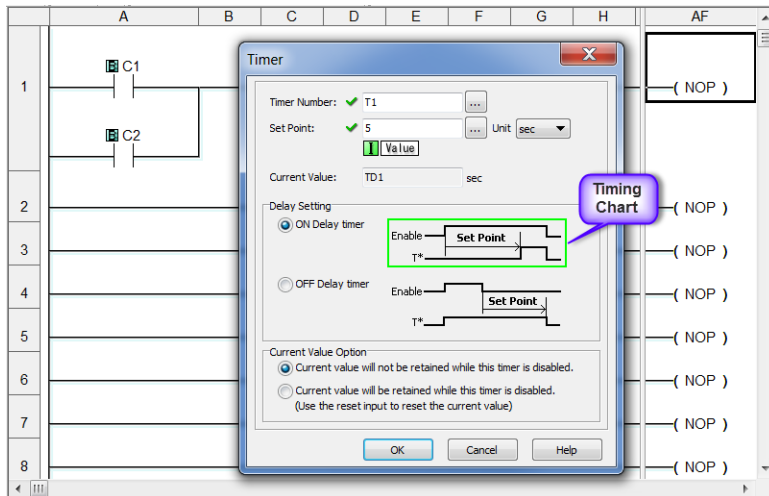

Leave the Delay Setting at ON Delay Timer and the Current Value Option set for the first selection. Click OK. A timer labeled T1 will be placed at the end of Rung #1.

**Proceed to the next page to enter Rung #2.**

## Step 3: Create a Project (cont'd)

### Rung #2

Place the Box Cursor at the beginning of Rung #2. From the Instruction List, click and drag a Contact (NO) into this box. Enter T1 into the Bit Memory Address text box of the Contact Normally Open dialog box that pops up. Click OK. A normally open contact labeled T1 will be placed in the beginning of Rung #2.

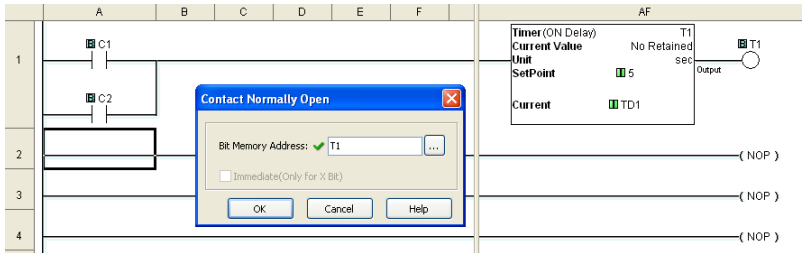

Next, place the Box Cursor on the NOP coil at the far right of Rung #2. Click and drag an OUT from the Instruction List into this location. Within the Out dialog box, enter Y001 into the Bit Memory Address: text box. Click OK. An out coil labeled Y001 will be placed at the end of Rung #2.

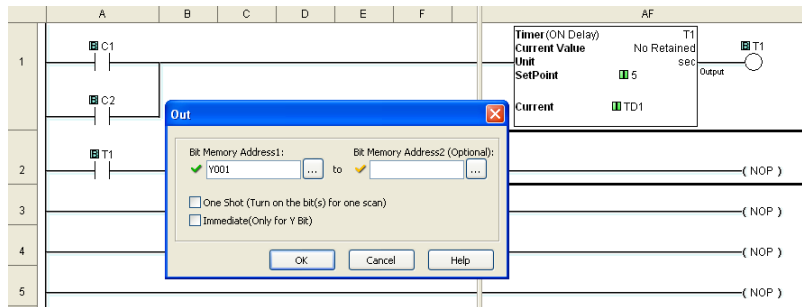

### Rung #3

Finally, place the Box Cursor on the NOP coil at the far right of Rung #3. Click and drag an END from the Instruction List into this location. An END instruction indicates the last part of the main ladder logic program. You have created your first project!

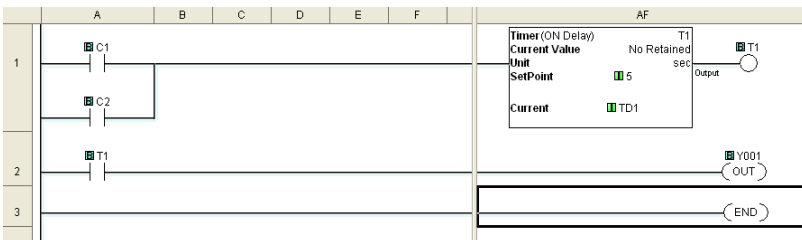

### Step 3: Create a Project (cont'd)

#### Program Execution

The following is an explanation of how the CLICK PLC executes the ladder logic program that was just entered.

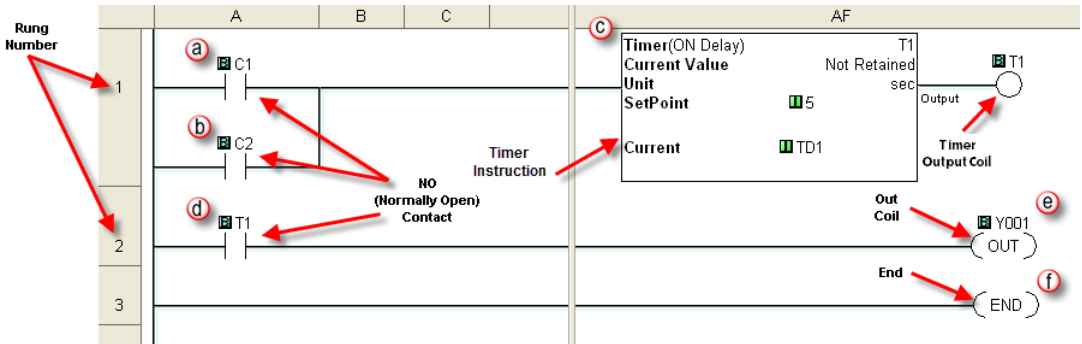

The CLICK PLC executes the ladder logic program instructions, starting with Rung #1, from left to right, and then proceeds to execute the next rung in the same fashion, carrying on through all of the rungs in sequential order. The 6 instructions (a, b, c, d, e and f) in the above ladder logic program are executed in the following order.



#### Explanation of the Program Execution

- a b** NO (Normally Open) Contact: Address C1 and C2 are assigned to a NO Contact. C1 and C2 are internal control bits. The internal control bits are 1 bit memory and hold the status of ON or OFF. The contacts are enabled when the status of C1 or C2 is ON.
- c** Timer: This instruction is used to delay an action once it is enabled. The CLICK PLC unit can use up to 500 timers (T1 to T500) in a project. In this ladder logic program, timer T1 is assigned. The Timer instruction is set up as an ON Delay Timer with a 5 second set point. That is, the timer status bit T1 output coil turns on 5 seconds after the enable input of the Timer instruction turns on.
- d** This is a NO Contact addressed as T1 and whose status is controlled by Timer T1. The contact is enabled when Timer T1 output coil becomes true after the 5 second delay.
- e** OUT: This is an output coil addressed as real world output Y001, which happens to be the first output on the CLICK PLC unit. It becomes active when the T1 NO Contact in this rung becomes enabled.
- f** END: This is the END of the ladder logic scan, and causes the scan to start at the beginning.

## Step 4: Compile and Save Project

### Syntax Check (Compile)

Next, you will need to compile the ladder logic program. Compiling the program is done with the Syntax Check function. The ladder program is checked for problems and other conditions that may prevent the ladder program from executing correctly. The results of the Syntax Check are displayed in the Output Window at the bottom of the Main Window as shown below.



From the Program drop down menu, select Syntax Check as shown at left, or press the F8 function key on your keyboard, or click on the Syntax Check icon located on the Program Toolbar.

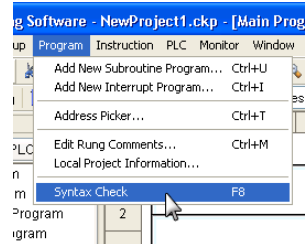

If everything in the program checks out correctly, then the Output Window will indicate 0 error(s) as shown in the following example.



If there are any errors, they will be indicated in the Output Window. For quicker troubleshooting, double click on any particular error in the Output Window and be taken directly to the rung and instruction that may be causing the error. The following is an example of an error.

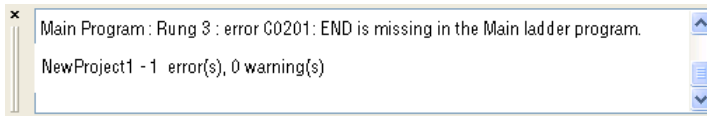

### Save Project

It is always a good practice to save your project at this point. From the File drop down menu, select Save Project, as shown here, or click on the Save Project icon located on the File Toolbar.

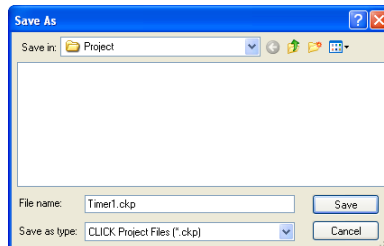
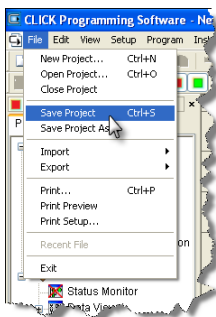

Enter the File Name for your project in the Save As dialog box. You can also browse to the folder that you want the project saved under. Click Save.

## Step 5: Apply Power

The CLICK PLC system works with 24 VDC power. There is a small terminal block on the bottom of the CLICK PLC unit. Wire the 24 VDC output from a CLICK power supply, or a properly sized and rated 24 VDC power supply such as AutomationDirect's RHINO series, to the bottom terminal block (See Chapter 2: Specifications for power supply specifications.)

### EITHER

Using a CLICK 24 VDC Power Supply.

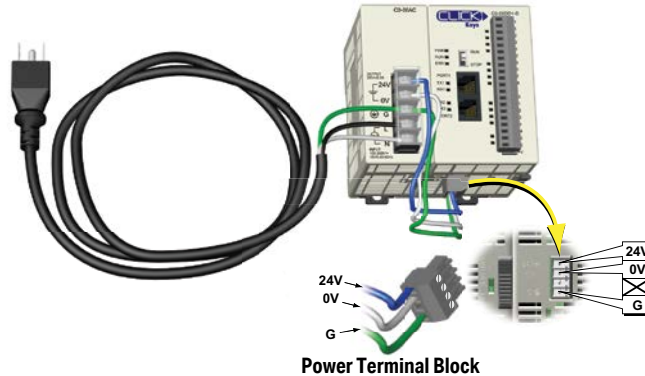

### OR

Using an alternate 24 VDC Power Supply.

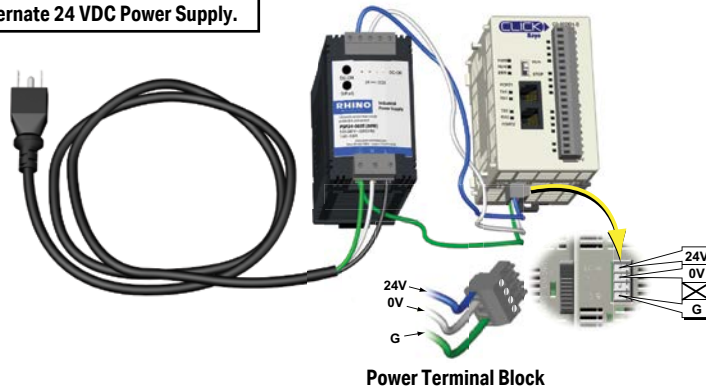

Once you wire and power up the power supply, confirm the PWR indicator (Green LED) on the CLICK PLC unit is on.

If the PWR indicator is not on, check the voltage on the terminal block with a voltage meter. If you measure 24 VDC on the terminal block, the CLICK PLC unit may be defective. Please try another one or contact us for a replacement.



## Step 6: Establish PC to PLC Communications

Next, connect a personal computer (PC) to Port 1 or Port 2 on the CLICK PLC unit. You can use one of the following communication ports on the CLICK PLC unit for programming.

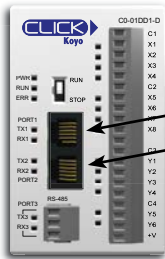

Port 1 (RS-232)

Port 2 (RS-232)

Basic PLC  
Standard PLC  
Analog PLC

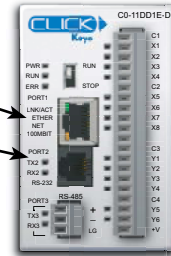

Port 1 (Ethernet)

Port 2 (RS-232)

Ethernet Basic PLC  
Ethernet Standard PLC  
Ethernet Analog PLC



**NOTE:** Port 2 (RS-232) setup can be changed by the customer. We recommend using Port 1 for Programming.

## Step 6: Establish PC to PLC Communications (cont'd)

### Using an RS-232 port for Programming

#### EITHER

If a USB port is available on the PC, then use an AutomationDirect USB to RS232 PC to Panel Programming Cable Assembly (P/N - EA-MG-PGM-CBL) to connect between the USB port on the PC and the RJ12 connector on the PLC's Port 1.

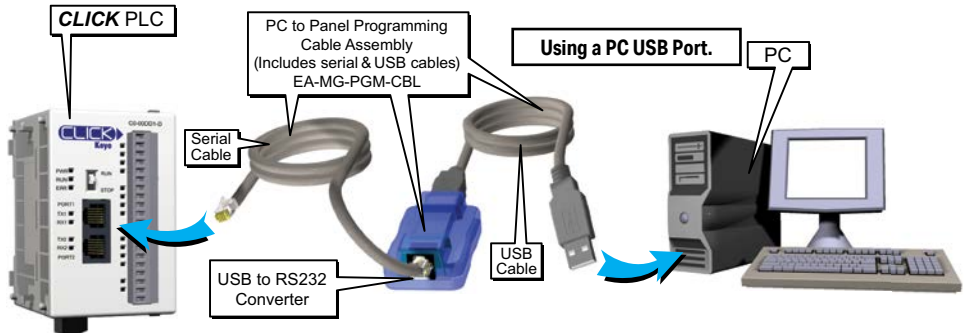

If a 9-pin RS-232 serial communications port is available on the PC, then use an AutomationDirect PC Serial Programming Cable (P/N - D2-DSCBL) to connect between the 9-pin port on the PC and the RJ12 connector on the PLC's Port 1.

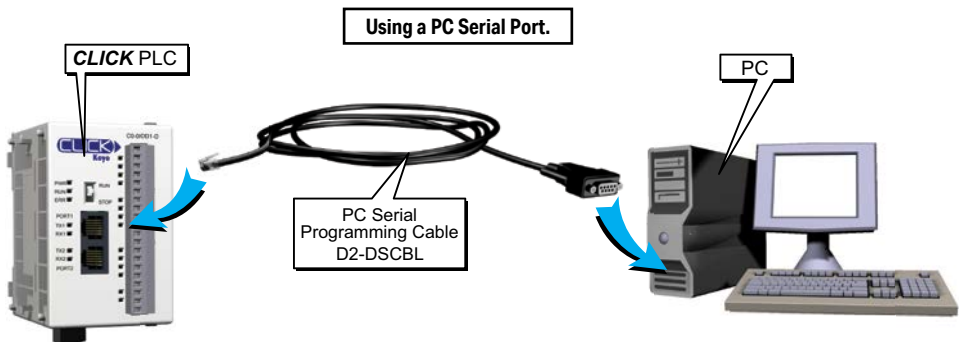

**NOTE:** Port 1 (RS-232) on the CLICK PLC unit is designed as the primary programming port. The port has fixed communication parameters, so you can always connect the programming software to the CLICK PLC unit through the port without any configuration changes.

## Step 6: Establish PC to PLC communications (cont'd)

Once we have a communications cable connected between a port on the PC and PORT1 on the CLICK PLC, we need to select the PC COM port that is connected to the CLICK PLC. From the PLC drop down menu, select Connect as shown to the right, or click on the Connect icon (left) located on the PLC Toolbar.



The Connect to PLC dialog box will be displayed. Under the COM Port No.: drop down list, select the communications port that is connected to the CLICK PLC Port 1.

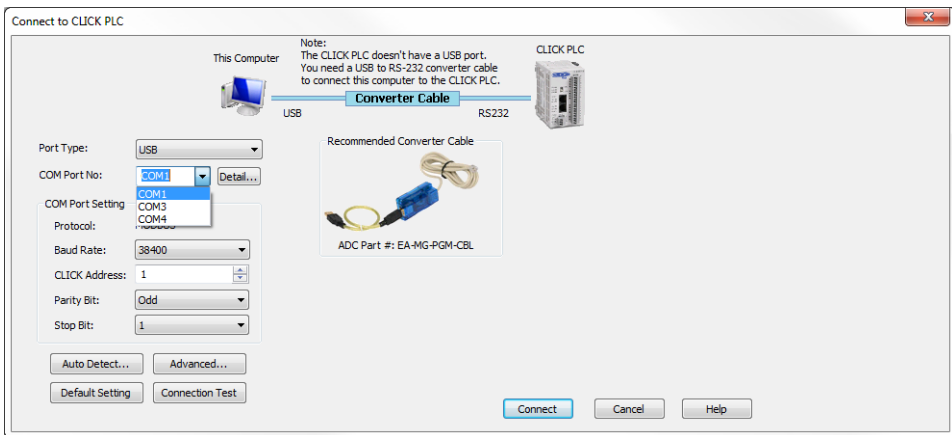
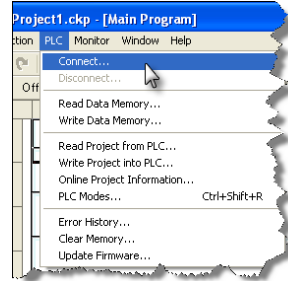

If you are connecting the programming cable to Port 1 on the CLICK PLC unit, you do not need to change any of the parameters, just click the Connect button. The software should start to immediately connect to the CLICK PLC.

If you cannot connect the software to the CLICK PLC, try the above procedure one more time and keep watching the TX1 and RX1 indicators on the CLICK PLC unit.

If the RX1 is not blinking, it means the CLICK PLC unit is not receiving any data from the programming software. Check to make sure you have selected the correct PC COM Port, and also check the cable connections.

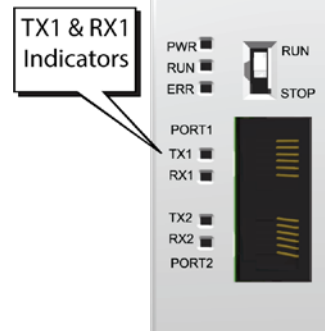

## Step 6: Establish PC to PLC Communications, (cont'd)



**NOTE:** If using the USB to RS232 converter, and you are not sure to which PC COM Port the USB port is assigned, click the Detail... button next to the COM Port drop down list to identify it. The screen to the right shows the Koyo USB-Serial Com Port device assigned to COM3. Select it and click OK.

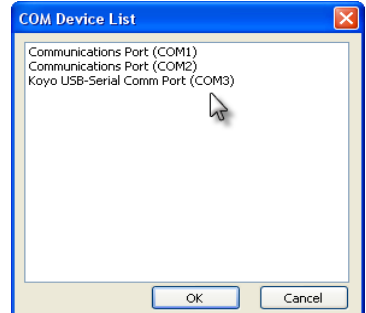

Proceed to page 1-24

## Step 6: Establish PC to PLC Communications, (cont'd)

### Using Ethernet Port for Programming

You can connect your PC to the CLICK PLC via an Ethernet switch/hub or directly to the Ethernet port. You can use a straight or crossover Ethernet cable.

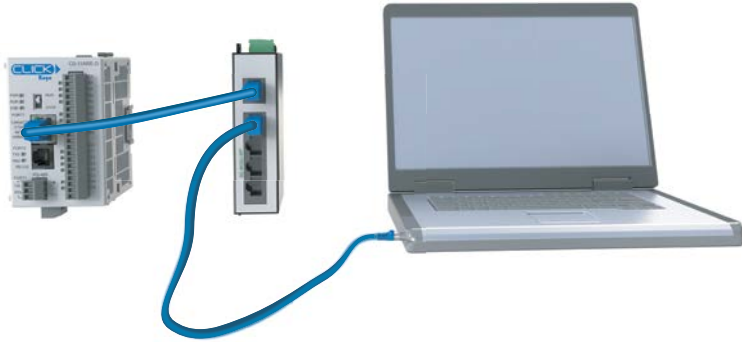

Once we have communications cable(s) connected between the Ethernet port on the CLICK PLC and the Ethernet port on the PC, we are ready to connect the CLICK Programming Software to the CLICK PLC. From the PLC drop down menu, select Connect as shown to the right, or click on the **Connect** icon located on the PLC Toolbar.

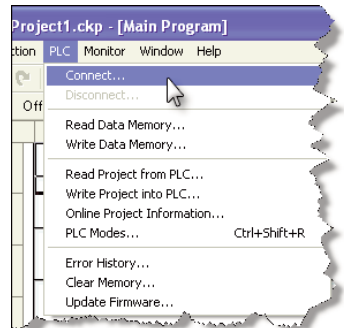

## Step 6: Establish PC to PLC Communications, (cont'd)

Select Ethernet as the Port Type. Select the network adapter that you want to connect to the CLICK PLC, if you have more than one network adapter on your PC. The CLICK programming software automatically scans the CLICK PLC units in the LAN connected to the network adapter and displays them in the list as shown below.

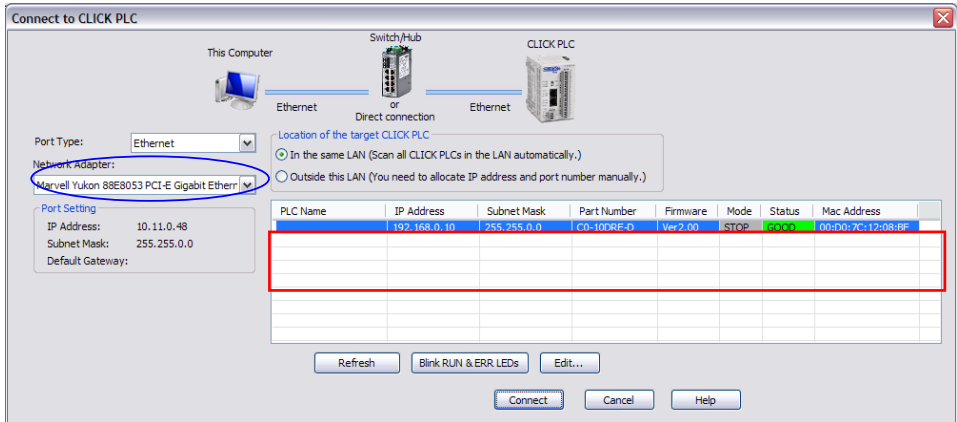

To connect the CLICK programming software to the CLICK PLC, both the PC and the CLICK PLC must be in the same subnet. In the above **Connect to CLICK PLC** window, the IP Address of the PC is '10.11.0.48' and the Subnet Mask is '255.255.0.0'. You can determine the subnet that your PC is located in by applying the AND operation between the IP Address and the Subnet Mask.

Example:

```

IP Address = 10.11.0.48
          AND
Subnet Mask = 255.255.0.0
          ||
          Subnet = 10.11.0.0
  
```

## Step 6: Establish PC to PLC Communications, (cont'd)

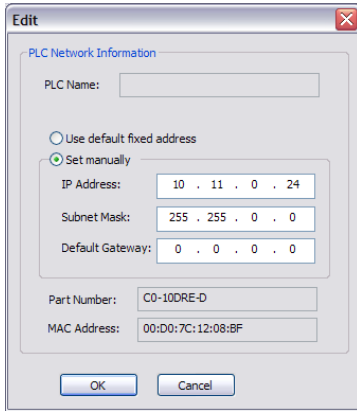

To match the subnet setup of the CLICK PLC to the subnet that the your PC locates in, select the CLICK PLC unit in the list and click the **Edit** button under the list. The Edit window opens.

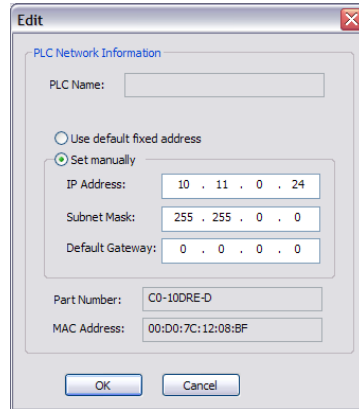

Next, the new IP Address needs to start with '10.11' to match the subnet of the PC. The following 2 numbers however, can be any number as long as the new IP Address is unique in the LAN. In the window here, the IP Address was changed to '10.11.0.24'.

Click the **OK** button to continue. The new IP Address setup is sent to the CLICK PLC.

Your PC and the CLICK PLC locate in the same subnet now. Click the **Connect** button on the bottom to connect the CLICK programming software to the CLICK PLC.

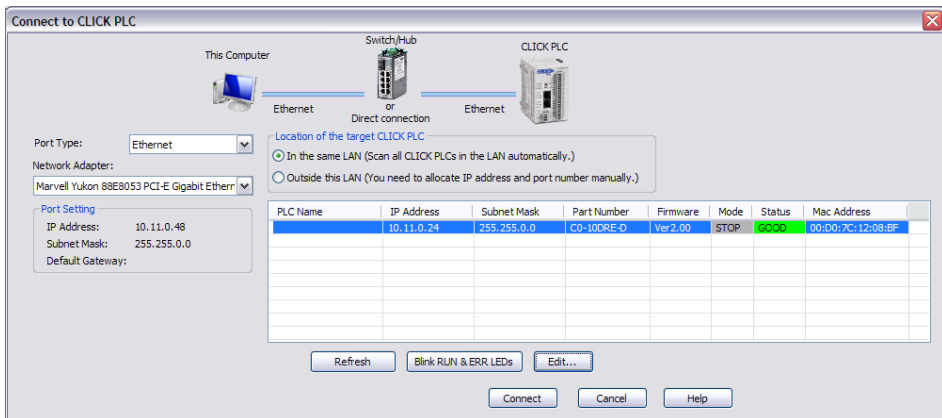

## Step 6: Establish PC to PLC Communications, (cont'd)

If you are trying to connect the CLICK Programming Software to a new CLICK PLC or an older CLICK PLC that was reset to the factory default, you will see the following pop-up message once communication has been established with the CLICK PLC. This is because there is no user project in the CLICK PLC currently. Click the OK button to close the message and proceed to the next step.

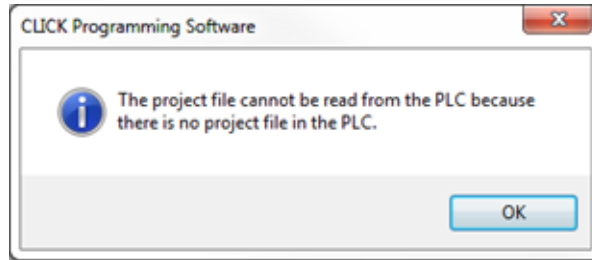

If you are trying to connect the CLICK Programming Software to a CLICK PLC that already has a user project, the following Connect dialog box will appear.

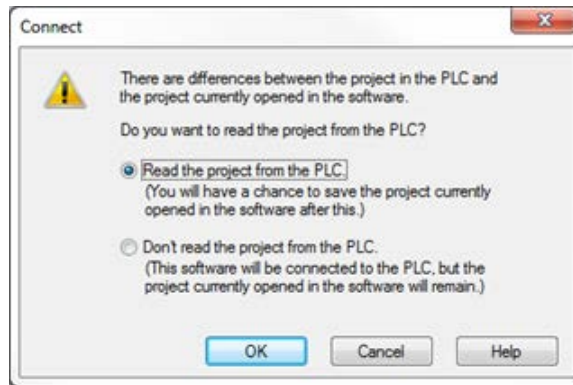

It is not unusual that the project opened in the programming software will not match the project that resides in the PLC. The dialog box gives you a choice to either read the PLC's project for viewing purposes, but at the same time allowing the project opened in the software to still be saved, or not read the project in the PLC.

For the Getting Started exercise, click the radio button for the “**Don't read the project from the PLC**” and click OK. Proceed to the next step which will allow the created project to be written into the CPU memory.

## Step 7: Write Project into PLC



The next step is used to transfer the project that was created into the CLICK PLC. From the PLC drop down menu, select Write Project into PLC as shown to the right, or click on the Write Project into PLC icon located on the PLC Toolbar.

The following dialog box is displayed.

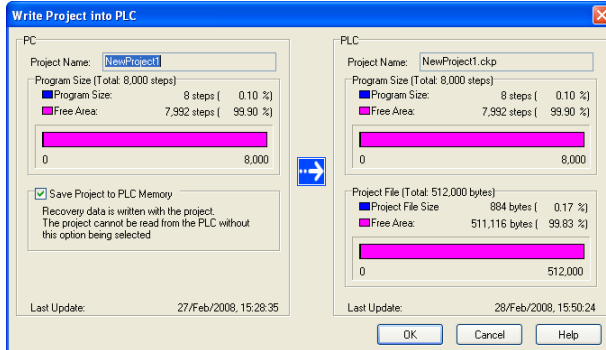
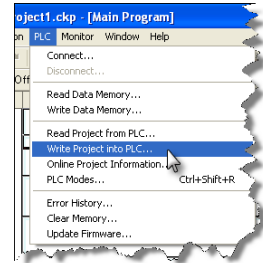

The dialog box displays the information for the Project that is currently opened in the programming software (PC) on the left side. The dialog box also displays the information for any Project that may be stored in the CLICK PLC unit (PLC) on the right side.

Click **OK** to write the project data from the PC to the CLICK PLC unit.

The **Writing...** progress window will open to allow verification that the Project is being written to the CPU. When finished, a Transfer Completed message will be displayed. Click **OK** to continue.

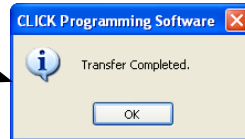
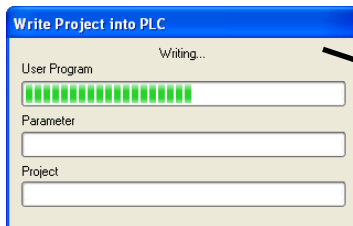

## Step 8: Place PLC in RUN Mode



The next step is to place the CLICK PLC into its Run mode so that the ladder logic program will execute. From the PLC drop down menu, select **PLC Modes...** as shown to the right, or click on the PLC Modes... icon (left) located on the PLC Toolbar.

The PLC Modes dialog box is displayed.

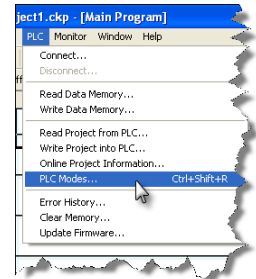
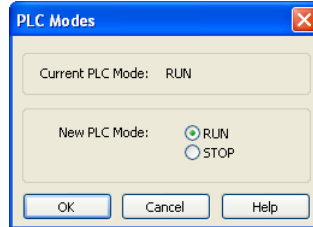

Click the radio button for RUN and then click the OK button. The CLICK PLC is now in Run mode and executing your ladder logic program.



**NOTE:** The PLC Modes dialog box can also be accessed by clicking on the Connection status (Offline/Run/Stop) indicator button that is located on the toolbar.

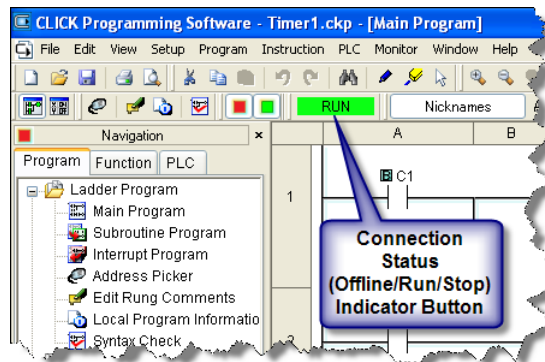

## Step 9: Test Project using Data View Monitor

In this next step, use the Data View Monitor to test the ladder logic program by manually overriding the status of the internal C1 bit that was programmed. The purpose of this will be to have the C1 bit enable Timer T1. From the Navigation window on the left side of the development screen, select the Program tab, open the Data View folder under Monitor and double click on DataView1.

The Data View window is displayed.

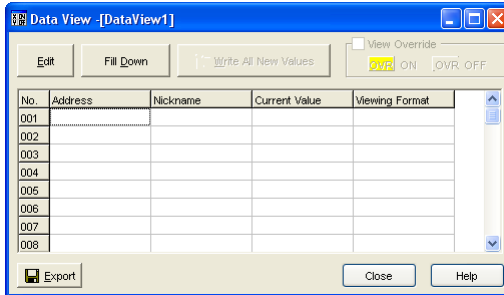
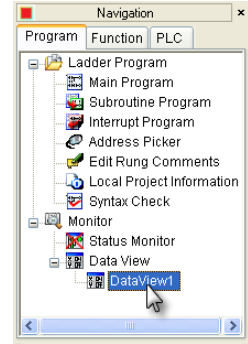

Click the Edit button and type in C1 as the Address as shown below.

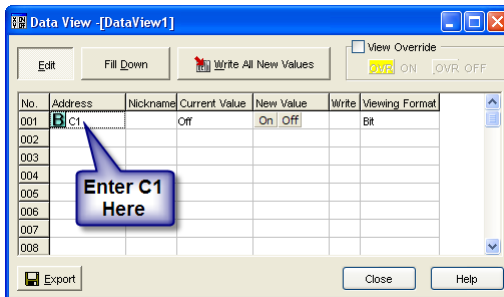

Double click the ON button in the New Value column. The Current Value of the C1 bit changes from OFF to ON. Go to Step 10: “Y001 Output On?”

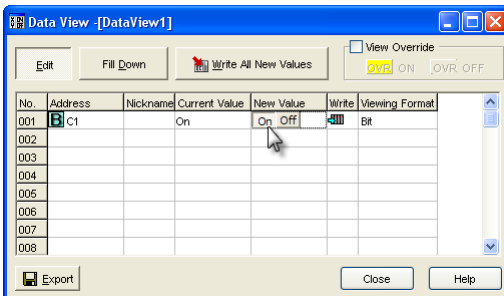

## Step 10: Y001 Output On?

CLICK PLC output Y001 (labeled Y1 on the PLC unit) will turn on 5 seconds after you write the ON state to the C1 bit using Data View in the Edit mode.

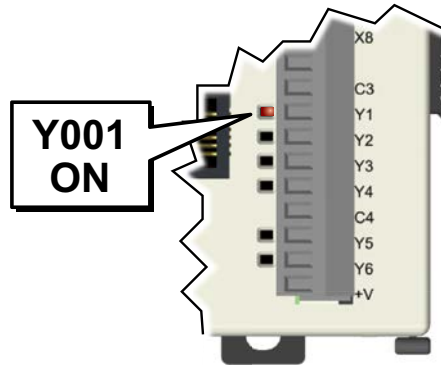

If you missed viewing the transition of the Y001 status LED from OFF to ON, write an OFF state to the C1 bit and then an ON state in the Data View Monitor to do it again.



---

**NOTE:** Also, try changing the status of the internal C2 bit. The results should be the same because the C2 bit is in parallel with the C1 bit. The ladder logic reads: "Enable timer T1, if either C1 or 'C2 is true."

---

## Congratulations!

You have now learned how to create, compile and transfer a ladder logic project to a CLICK PLC, and then run and test the project. There are additional instructions available for the CLICK PLC. Please refer to the programming software online help topics for details on these instructions.

Again, thank you very much for using the CLICK PLC system.

## Additional Training Resources

In addition to this Getting Started chapter, there are other resources we recommend, for both the novice and pros, that will aid you in learning more about using the CLICK PLC system.

**Automationdirect.com Online Video Site - <http://automationdirect.com/videos/home>** is an online video tutorial site offering free on-demand video tutorials on a wide range of practical industrial products, including the CLICK PLC.

From the Automationdirect.com home page, select (a) “Video Tutorials”. When the page opens select (b) “Programmable Controllers” on the top, lefthand topic bar for Video Filter list. Select (c) “CLICK series PLCs”. A page of CLICK specific videos will open. A search for CLICK (d) will pull up all the CLICK videos as well. The videos cover all aspects of the CLICK PLC, from an introductory video, to communications, and programming.



Interconnecting Automation Online Training Courses offered at-

<http://www.interconnectingautomation.com/onlinecourses>

Interconnecting Automation offers inexpensive subscription-based online training, including CLICK PLC training.

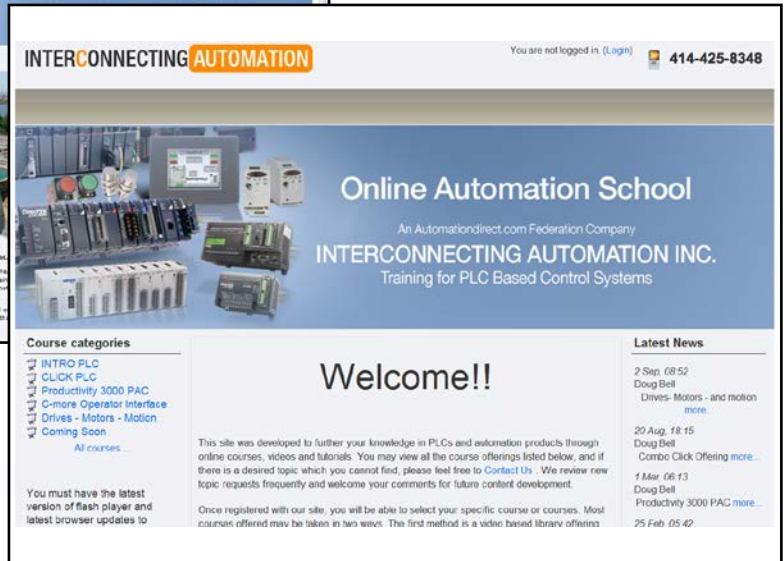
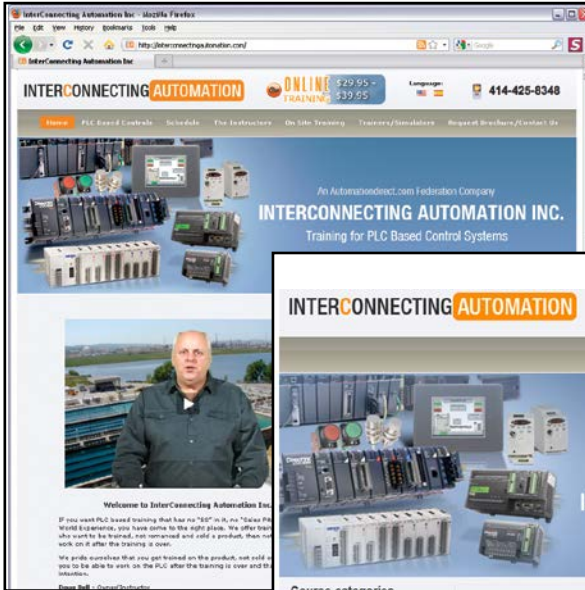

Also, a CLICK PLC Trainer is available from this web site.



# SPECIFICATIONS

---



# CHAPTER 2

## In This Chapter...

Overview of PLC System .....	2-2
PLC Units .....	2-3
I/O Modules .....	2-10
Programming Software .....	2-14
Data Types, Memory, and Numbering System .....	2-15
PLC Operation.....	2-19
Power Budgeting.....	2-23
General Specifications .....	2-26
PLC Unit Specifications .....	2-27
Basic PLC Unit Specifications .....	2-36
Standard PLC Unit Specifications.....	2-44
Analog PLC Unit Specifications.....	2-52
Ethernet Basic PLC Unit Specifications .....	2-61
Ethernet Standard PLC Unit Specifications.....	2-69
Ethernet Analog PLC Unit Specifications .....	2-77
I/O Module Specifications .....	2-113
Power Supply Specifications.....	2-150
Accessories.....	2-151

# Overview of PLC System

The CLICK PLC family of components is designed to combine practical PLC features in a compact and expandable design, with a simple-to-use philosophy. A powered CLICK PLC unit by itself can be used as a complete PLC system with built-in I/O points, or the system can be expanded with the addition of up to eight I/O modules. The CLICK PLC system does not require a mounting base. The CLICK PLC and I/O modules are connected together via an expansion port on the right side of the PLC case. A variety of I/O modules are available for flexible and optimal system configuration. The CLICK PLC supports a very simple but useful instruction set. There are 21 easy-to-use instructions that cover most applications that are suitable for this class of PLC.

Use a CLICK PLC unit as a stand-alone controller..

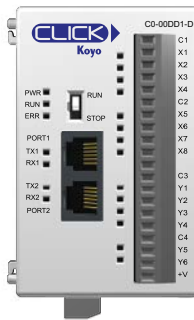

or, expand the system by installing up to eight additional I/O modules.

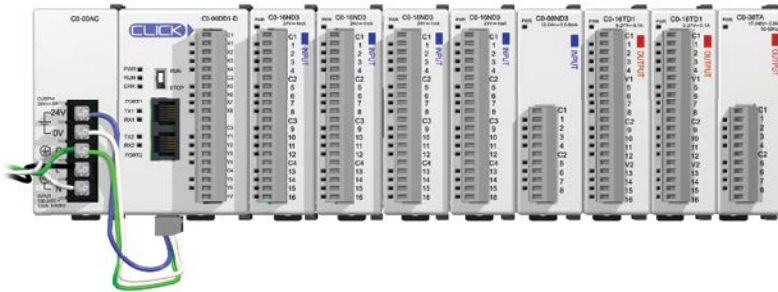

**NOTE:** It is not necessary to use the CLICK PLC with a CLICK power supply. An alternately regulated, properly-sized 24VDC power source can be used to power the PLC and can also provide 24VDC to any optional I/O modules used in the CLICK PLC hardware configuration. Please refer to the Power Budgeting section later in this chapter for details on choosing the correct size power supply.

## PLC Units

All CLICK PLC units offer the same instruction set, and support all optional I/O modules. The six types of PLC units available are listed in the table below.

PLC Types	Discrete I/O		Analog I/O		Communication Ports			Battery Backup	RUN time Edit
	Inputs	Outputs	Inputs	Outputs	Port 1	Port 2	Port 3		
Basic	8	6	N/A	N/A	RS-232	RS-232	N/A	Yes	N/A
Standard	8	6							
Analog	4	4	2	2					
Ethernet Basic	8	6	N/A	N/A	Ethernet	RS-232	N/A	Yes	Yes
Ethernet Standard	8	6							
Ethernet Analog	4	4	2	2					
			4	2			RS-485		

### Basic PLC Units

The Basic CLICK PLC units are available with different combinations of built-in I/O (i.e. DC input/DC output, DC input/relay output, and AC input/relay output).

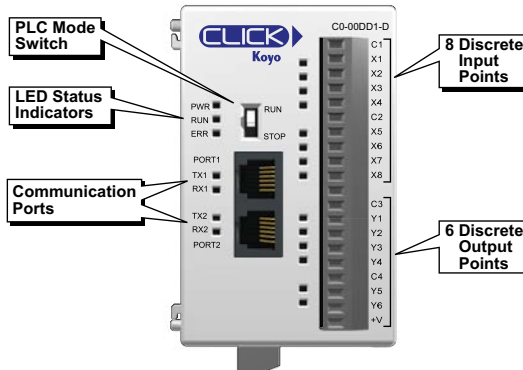

### Built-in I/O (Basic PLC Units)

There are four different configurations of I/O types available for the Basic CLICK PLC units. The table below lists the part numbers showing the various I/O configurations.

Basic PLCs			
Part Number	Discrete Input Type	Discrete Output Type	External Power
C0-00DD1-D	8 DC (sink/source)	6 DC (sink)	24VDC (required for all PLC units)
C0-00DD2-D		6 DC (source)	
C0-00DR-D		6 Relay	
C0-00AR-D		8 AC	

### Standard PLC Units

The Standard CLICK PLC units are available with different combinations of built-in I/O types (i.e. DC input/DC output, DC input/relay output, and AC input/relay output).

They also have an RS-485 port for Modbus RTU and ASCII communications, and the battery backup feature which will retain the data in SRAM for 3 years.

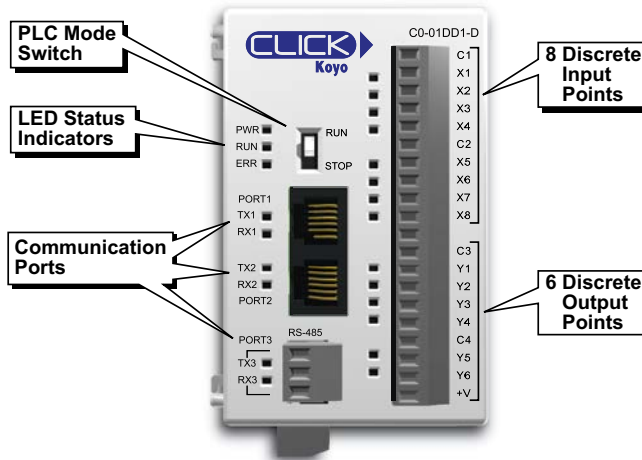

### Built-in I/O (Standard PLC Units)

There are four different configurations of I/O types available for the Standard CLICK PLC units. The table below lists the part numbers showing the various I/O configurations.

Standard PLCs			
Part Number	Discrete Input Type	Discrete Output Type	External Power
CO-01DD1-D	8 DC (sink/source)	6 DC (sink)	24VDC (required for all PLC units)
CO-01DD2-D		6 DC (source)	
CO-01DR-D	8 AC	6 Relay	
CO-01AR-D			

## Analog PLC Units

The Analog CLICK PLC units are available with different combinations of DC in, DC sinking, sourcing or relay out, and analog in and out.

They also have an RS-485 port for Modbus RTU and ASCII communications, and the battery backup feature which will retain the data in SRAM for 3 years.

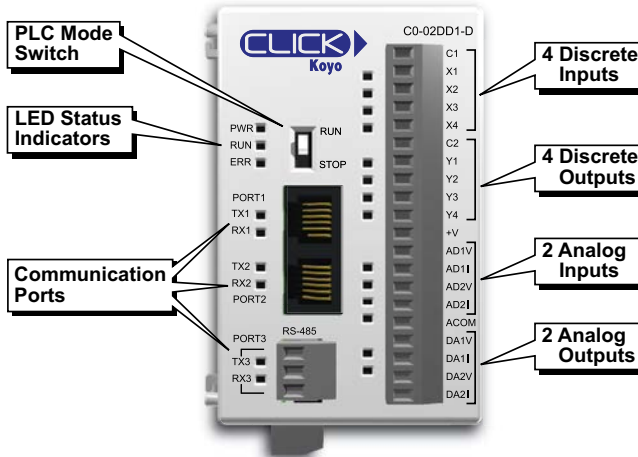

## Built-in I/O (Analog PLC Units)

There are three different configurations of I/O types available for the Analog CLICK PLC units. The table below lists the part numbers showing the various I/O configurations.

Analog PLCs					
Part Number	Discrete Input Types	Discrete Output Types	Analog Input Types	Analog Output Types	External Power
C0-02DD1-D	4 DC (sink/ source)	4 DC (sink)	2 channel; voltage (0–5 VDC) / current (4–20 mA); selectable separately per channel, 12-bit	2 channel; voltage (0–5 VDC) / current (4–20 mA); selectable separately per channel, 12-bit	24VDC (required for all PLC units)
C0-02DD2-D		4 DC (source)			
C0-02DR-D		4 relay			



**NOTE:** There is a dedicated terminal for each voltage or current type, but you must also select the voltage or current type in the CLICK programming software. See the Analog I/O Configuration section in Chapter 3.

### Ethernet Basic PLC Units

The Ethernet Basic CLICK PLC units are available with different combinations of built-in I/O types, e.g. DC input /DC output, DC input/relay output, and AC input/relay output. Four types of Ethernet Basic PLC units are available.

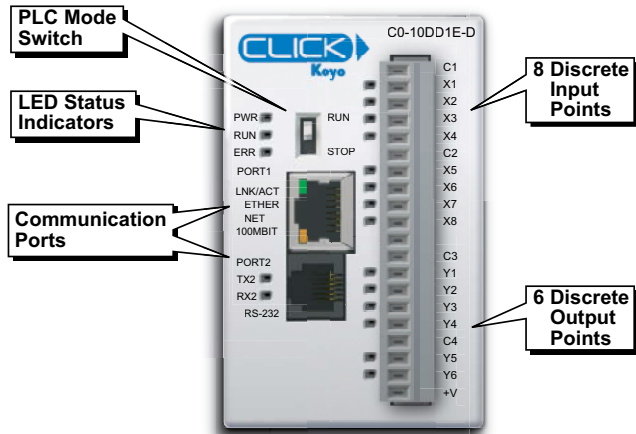

### Built-in I/O (Ethernet Basic PLC Units)

There are four different configurations of I/O types available for the Ethernet Basic CLICK PLC units. The table below lists the part numbers showing the various I/O configurations.

Ethernet Basic PLCs			
Part Number	Discrete Input Type	Discrete Output Type	External Power
C0-10DD1E-D	8 DC (sink/source) 4 points High-Speed	6 DC (sink)	24VDC (required for all PLC units)
C0-10DD2E-D		6 DC (source)	
C0-10DRE-D		6 Relay	
C0-10ARE-D	8 AC		

### Ethernet Standard PLC Units

The Ethernet Standard CLICK PLC units are available with different combinations of built-in I/O types, e.g., DC input /DC output, DC input/relay output, and AC input/relay output.

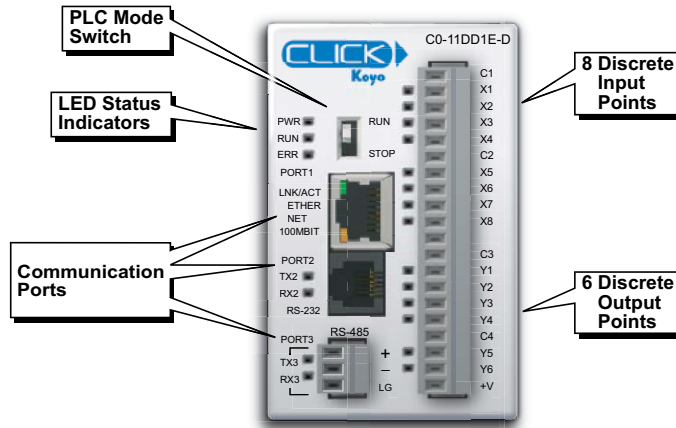

### Built-in I/O (Ethernet Standard PLC Units)

There are four different configurations of I/O types available for the Ethernet Standard CLICK PLC units. The table below lists the part numbers showing the various I/O configurations.

Ethernet Standard PLCs			
Part Number	Discrete Input Type	Discrete Output Type	External Power
C0-11DD1E-D	8 DC (sink/source) 8 points High-Speed	6 DC (sink)	24VDC (required for all PLC units)
C0-11DD2E-D		6 DC (source)	
C0-11DRE-D		6 Relay	
C0-11ARE-D			

### Ethernet Analog PLC Units

The Ethernet Analog CLICK PLC units are available with different combinations of built-in I/O types, e.g., DC input /DC output, DC input/relay output, and AC input/relay output, and analog in and out.

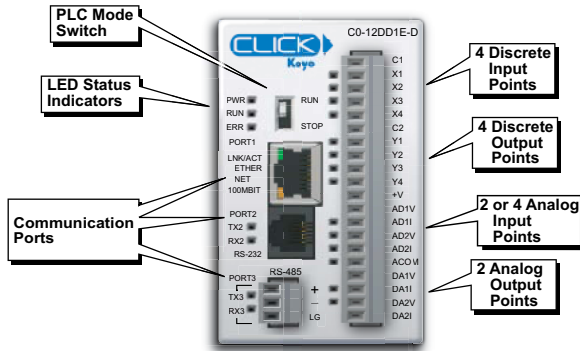

### Built-in I/O (Ethernet Analog PLC units)

There are twelve different configurations of I/O types available for the Ethernet Analog CLICK PLC units. The table below lists the part numbers showing the various I/O types.

Ethernet Analog PLCs					
Part Number	Discrete Input Types	Discrete Output Types	Analog Input Types	Analog Output Types	External Power
C0-12DD1E-D*	4 DC	4 DC (sink)	2 channel; voltage (0–5 VDC) / current (4–20 mA); selectable separately per channel, 12-bit	2 channel; voltage (0–5 VDC) / current (4–20 mA); selectable separately per channel, 12-bit	24VDC (Required for all PLC units)
C0-12DD2E-D*	(sink/source)	4 DC (source)			
C0-12DRE-D*	4 points High-Speed	4 relay			
C0-12ARE-D*	4 AC				
C0-12DD1E-1-D	4 DC	4 DC (sink)	4 channel; current (0–20 mA), 12-bit	2 channel; current (4–20 mA), 12-bit	
C0-12DD2E-1-D	(sink/source)	4 DC (source)			
C0-12DRE-1-D	4 points High-Speed	4 relay			
C0-12ARE-1-D	4 AC				
C0-12DD1E-2-D	4 DC	4 DC (sink)	4 channel; voltage (0–10 VDC), 12-bit	2 channel; voltage (0–10 VDC), 12-bit	
C0-12DD2E-2-D	(sink/source)	4 DC (source)			
C0-12DRE-2-D	4 points High-Speed	4 relay			
C0-12ARE-2-D	4 AC				

\* These four PLC units require that you select I/O as voltage or current type in the CLICK programming software. See the Analog I/O Configuration section in Chapter 3.

## Communication Ports

The Basic CLICK PLC units have two built-in RS-232 serial communications ports. Standard and Analog PLC units also have an additional RS-485 port. All CLICK Ethernet PLC units have one built-in Ethernet communication port and one RS-232 serial communication port. Ethernet Standard and Ethernet Analog PLC units also have an additional RS-485 port. See Chapter 4: *Communications* for details on the proper use of these ports.

## Memory

All CLICK PLC units have a non-volatile FLASH ROM to store the downloaded ladder program and project file. The FLASH ROM will retain the ladder program even with power removed from the PLC module.

The CLICK PLC units make use of data registers to store values and conditions that are used during program execution. This data is stored in the SRAM memory. It is volatile memory, but is backed up by a super capacitor. The super capacitor is a special type of capacitor that is designed to provide power to volatile memory like the SRAM when the power to the PLC is off. However, it will not back up the memory for an extended time. In the case of the CLICK PLC, the super capacitor will back up the SRAM for the following period after the power is shut off. Once the super capacitor is discharged, all data in the SRAM is cleared when the CLICK PLC is powered up the next time.

CLICK PLC Unit	Backup Period by the Super Capacitor
Basic PLC units	7 days
Standard PLC units	
Analog PLC units	
Ethernet Basic PLC units	1 hour
Ethernet Standard PLC units	
Ethernet Analog PLC units	

### (Standard, Analog and Ethernet PLC Units Only)

Standard, Analog and all Ethernet PLC units have a battery backup feature that will retain data in the SRAM for three years. Use part number D2-BAT-1 as the replacement battery.

Refer to the PLC Unit Specifications section later in this chapter for more PLC information.

# I/O Modules

A variety of I/O modules is available for the CLICK PLC System. Up to 8 I/O modules can be connected to a CLICK PLC unit to expand the system I/O count and meet the needs of a specific application. Complete I/O module specifications and wiring diagrams can be found later in this chapter. Here are the I/O modules that are supported by the CLICK PLC system at this time.

## Discrete Input Modules

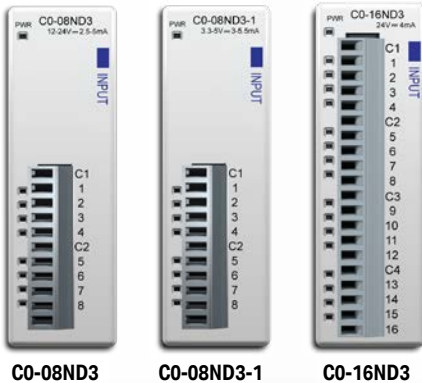

Discrete Input Modules		
Part Number	Input Type	Voltage Ratings
CO-08ND3	8 DC (Sink/Source)	12-24VDC
CO-08ND3-1	8 DC (Sink/Source)	3.3-5 VDC
CO-16ND3	16 DC (Sink/Source)	24VDC
CO-08NE3	8 AC/DC (Sink/Source)	24 VAC/VDC
CO-16NE3	16 AC/DC (Sink/Source)	24 VAC/VDC
CO-08NA	8 AC	100-120 VAC

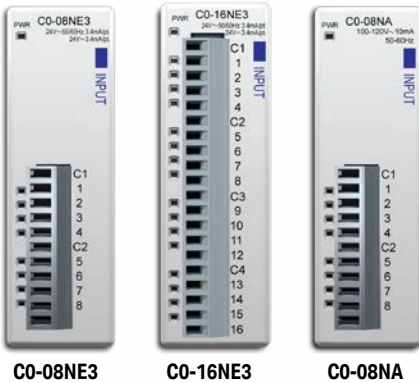

## Specialty Modules

Specialty Modules		
Part Number	Input Type	Voltage Ratings
CO-08SIM	8, Toggle Switch	N/A
CO-04POT	4, Potentiometer	N/A

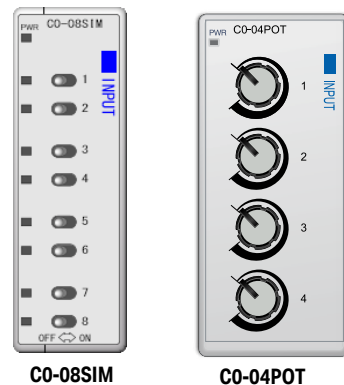

Discrete Output Modules



CO-08TD1



CO-08TD2



CO-16TD1



CO-16TD2



CO-08TA



CO-04TRS

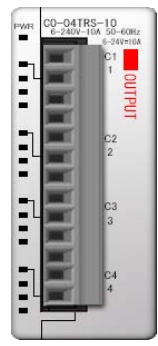

CO-04TRS-10



CO-08TR

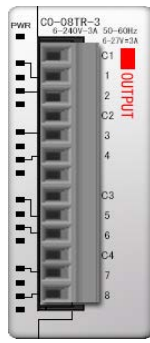

CO-08TR-3

Discrete Output Modules		
Part Number	Output Type	Voltage/Current Ratings
CO-08TD1	8 DC (Sink)	3.3-27 VDC / 0.3 A
CO-08TD2	8 DC (Source)	12-24 VDC / 0.3 A
CO-16TD1	16 DC (Sink)	5-27 VDC / 0.1 A
CO-16TD2	16 DC (Source)	12-24 VDC / 0.1 A
CO-08TA	8 AC	17-240 VAC / 0.3 A
CO-04TRS	4 Relay	6-27 VDC / 7A 6-240 VAC / 7A
CO-04TRS-10	4 Relay	6-240 VAC / 10A 6-240 VAC / 10A
CO-08TR	8 Relay	6-27 VDC / 1A 6-240 VAC / 1A
CO-08TR-3	8 Relay	6-27 VDC / 3A 6-240 VAC / 3A

Discrete Combo I/O Modules



CO-16CDD1



CO-16CDD2

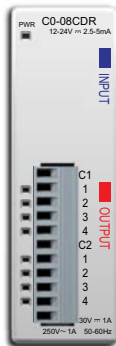

CO-08CDR

Discrete Combo I/O Modules				
Part Number	Input Type	Input Voltage	Output Type	Output Voltage / Current Ratings
CO-16CDD1	8 DC (sink/source)	24VDC	8 DC (sink)	5-27 VDC / 0.1 A
CO-16CDD2	8 DC (sink/source)	24VDC	8 DC (source)	12-24 VDC / 0.1 A
CO-08CDR	4 DC (sink/source)	12-24 VDC	4 (relay)	6.25-24 VDC / 1A 6-240 VAC / 1A

## Analog Input Modules

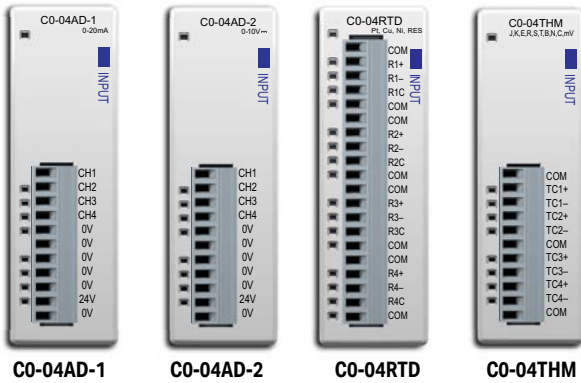

Analog Input Modules		
Part Number	Analog Input Types	External Power Required
CO-04AD-1	4 channel, current (0–20 mA), 13-bit	24VDC
CO-04AD-2	4 channel, voltage (0–10 V), 13-bit	24VDC
CO-04RTD	4 channel RTD input (0.1 degree °C/°F resolution), or resistive input (0–3125 Ω, 0.1 Ω or 0.01 Ω resolution)	None
CO-04THM	4 channel thermocouple input (0.1 degree °C/°F resolution), or voltage input (-156.25 mV to 1.25 V, 16-bit)	None

## Analog Output Modules

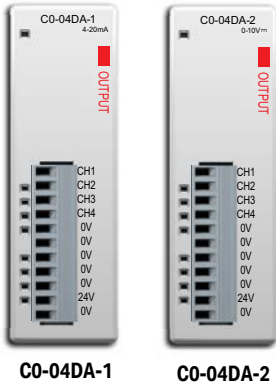

Analog Output Modules		
Part Number	Analog Output Types	External Power Required
CO-04DA-1	4 channel, current sourcing (4–20 mA), 12-bit	24VDC
CO-04DA-2	4 channel, voltage (0–10 V), 12-bit	24VDC

## Analog Combo I/O Modules

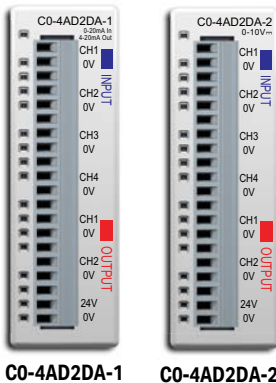

Analog Combo I/O Modules			
Part Number	Analog Input Type	Analog Output Type	External Power Required
CO-4AD2DA-1	4 channel, current (0–20 mA), 13-bit	2 channel, current sourcing (4–20 mA), 12-bit	24VDC
CO-4AD2DA-2	4 channel, voltage (0–10 V), 13-bit	4 channel, voltage (0–10 V), 12-bit	24VDC

## Power Supply

Two types of 24VDC power supplies are available for the CLICK PLC family. They are designed to attach to the left side of the CLICK PLC, creating a compact footprint. They are identical except for the output current rating. The 24VDC power is wired from the DC output terminals of the power supply to a removable power terminal block located on the bottom of the CLICK PLC unit.

**C0-00AC**  
**0.5 A**



**C0-01AC**  
**1.3 A**

CLICK 24VDC Power Supply Ratings	
Part Number	Output Current
<b>C0-00AC</b>	<b>0.5 A</b>
<b>C0-01AC</b>	<b>1.3 A</b>

### C0-00AC

The C0-00AC is a low-cost solution for applications requiring only minimal I/O and power consumption. This power supply will not support a fully-populated CLICK PLC system with all possible I/O module combinations.

### C0-01AC

The C0-01AC is designed to support a fully-populated CLICK PLC system with all possible I/O module combinations with no concerns of exceeding the power budget.

Please refer to the Power Supply Specifications section later in this chapter for specification details.



**NOTE:** It is not mandatory to use one of the above CLICK power supplies for the CLICK PLC system. A properly-sized and rated 24VDC power supply, such as some of those offered by [Automationdirect.com](http://Automationdirect.com), can also be used to power a CLICK PLC system.



12 VDC-to-24VDC Converter		
Part Number	Input Voltage	Output Current
<b>PSP24-DC12-1</b>	9.5-18 VDC	1.0A @ 24VDC

### PSP24-DC12-1

With this DC-DC converter you can operate the CLICK PLC with 12VDC input power. To select a power supply to use with your CLICK PLC system, you need to consider the total PLC system's power budget. Please refer to the Power Budget section of this chapter for details.

# Programming Software

The CLICK PLC Programming Software, which can be downloaded free from the Automationdirect.com web site (Downloads/Software), is designed to provide simple and fast application development of ladder logic programming.

These are some of the features that help make this happen:

- The Navigation window allows organization of the ladder logic programs used in your project and access to the functions, settings and configurations used to work with your project.
- The Instruction List window displays all available CLICK PLC instructions, allows you to drag and drop the instruction into your ladder logic program, and then enter any values and/or parameters required for the particular instruction.
- You can add Subroutine and Interrupt programs separately from the main ladder logic program. This allows you to manage your ladder logic programs in a simple, structured environment and, at the same time, aid in trouble-shooting your program.
- The Data View Monitor window configurations are saved with your project. This allows quick access to the same set of memory addresses that may have been set up for viewing during testing of your program.
- The graphical represented System Configuration dialog box allows checking the PLC system configuration. A Power Budget calculation feature is included. Refer to the Power Budgeting section later in this chapter for additional details.
- The Address Picker window allows quick selection of any memory address to be placed in the ladder logic program. Refer to the programming software online help for additional details.
- The PLC module Firmware can be updated from the programming software within 2 minutes.

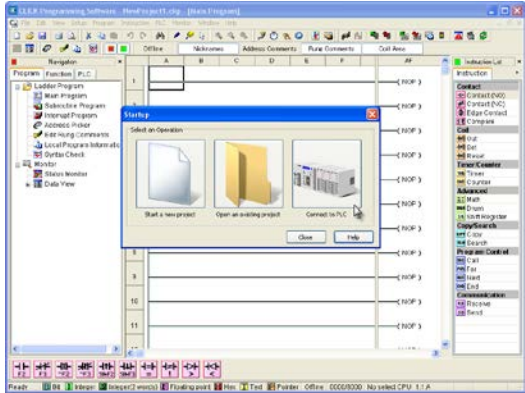

## PC Requirements

Check our online webstore for current operating system requirements:







<http://www.automationdirect.com>

## Data Types, Memory, and Numbering System

The following section explains how the CLICK PLC handles the available data types, memory addressing, and I/O numbering.

### Data Types

The CLICK PLC supports the following data types. On the CLICK PLC programming software, each data type is indicated with a small icon.











Data Type	S/W Icon	Data Ranges
Bit		0, 1
Integer (Single Word)		-32,768 to 32,767
Integer2 (Double Word)		-2,147,483,648 to 2,147,483,647
Floating Point		-3.4028235E+38 to 3.4028235E+38
HEX (Hexadecimal)		0000h to FFFFh (The HEX data type requires the 'h' after the value.)
Text (Single Character)		Single ASCII character (ASCII code: 00h to FFh.)
ASCII Code		ASCII code \$00 to \$FF (The ASCII Code data type requires the '\$' before the value.)



**NOTE:** The CLICK PLC does not support Octal or BCD numbering systems (data types).

### Memory Types

The following is the list of the memory types that the CLICK PLC system supports. See the memory map later in this chapter.

Memory Type	Symbol	Data Type	S/W Icon	Definition
Input Point	X	Bit		The Discrete Input points are represented by the "X" symbol.
Output Point	Y			The Discrete Output points are represented by the "Y" symbol.
Control Relay	C			The Control Relay bits are represented by the "C" symbol. These internal bits are typically used for ladder program control. They do not represent any real world inputs or outputs.
Timer	T			The Timers are represented by the "T" symbol. The Timer status bit is used to indicate when the Current Value of the timer equals its Preset Value.
Counter	CT			The Counters are represented by the "CT" symbol. The Counter status bit is used to indicate when the Current Value of the counter equals its Preset Value.
System Control Relay	SC			The internal System Control Relays, represented by the "SC" symbol, are pre-defined bits which represent the status of specific system functions.
Data Register	DS	Integer		Single word integer data registers are represented by the "DS" symbol.
	DD	Integer2		Double word integer data registers are represented by the "DD" symbol.
	DH	HEX		Single word Hex data registers are represented by the "DH" symbol.
	DF	Floating Point		Data Floating Point registers are IEEE format Real number values represented by the "DF" symbol as 32-bit words.
Input Register	XD	HEX		The Input Registers, represented by the "XD" symbol, contain groups of Discrete Input points in a 16-bit word format. XD0 is a Hexadecimal representation of X1-X16, XD1 of X101-X116, etc.
Output Register	YD			The Output Registers, represented by the "YD" symbol, contain groups of Discrete Output points in a 16-bit word format. YD0 is a Hexadecimal representation of Y1-Y16, YD1 of Y101-Y116, etc.
Timer Register	TD	Integer		The Timer Registers, represented by the "TD" symbol, contain the corresponding Timer's accumulative value in a 16-bit data register.
Counter Register	CTD	Integer2		The Counter Registers, represented by the "CTD" symbol, contain the corresponding Counter's accumulative value in a 32-bit data register.
System Data Register	SD	Integer		The internal System Data Registers, represented by the "SD" symbol, are pre-defined words which represent the status of specific system functions.
Text	TXT	Text		The Text data registers, represented by the "TXT" symbol, are used to store and manipulate ASCII text data.

## Memory Types (cont'd)

### Pointer Addressing

The CLICK PLC allows the use of Pointer Addressing for flexibility in programming. The Copy instruction supports Pointer Addressing in the single copy mode. The Pointer is always assigned as a DS memory type and is designated as a Pointer by placing the DS memory type in square brackets, such as [DS1]. Pointer Addressing uses the Pointer's data value to point to a memory location within the range of one of the eligible memory types. Pointer Addressing can be used with the DS, DD, DF, DH, XD, YD, TD, CTD and TXT data register memory types.

Pointer Addressing is also sometimes referred to as Indirect Addressing. One of the many uses for Pointer Addressing would be to perform lookup in tables. An application example might be determining the number of gallons in a horizontal tank when the liquid level is known. The gallons could be determined by a rather complex math formula, but a simpler approach would be to pre-calculate the number of gallons at several uniform levels, and place these values into a table of data registers that can be accessed using Pointer Addressing.

### Pointer Addressing Example

DS1 = 100; data register DS1 is assigned the value of 100.

Then the use of DD[DS1] would be the same as showing DD100.

As the value in DS1 is changed, the result would then point to a different DD data register.

In the example, data register DS1 is called a Pointer. Only a DS memory type can be used as a pointer. As mentioned before, the use of the [square brackets] around DS1 in the data register reference DD[DS1] is how the Pointer Addressing is designated.

## I/O Numbering System

The CLICK PLC uses decimal numbers for the input (X) and output (Y) addressing.

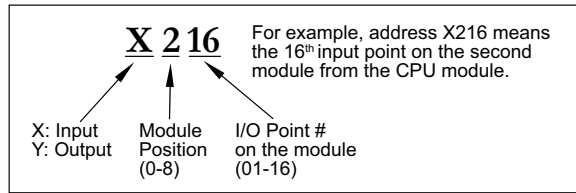

## Module Location

Please refer to the following diagram to understand the module position and I/O numbering.

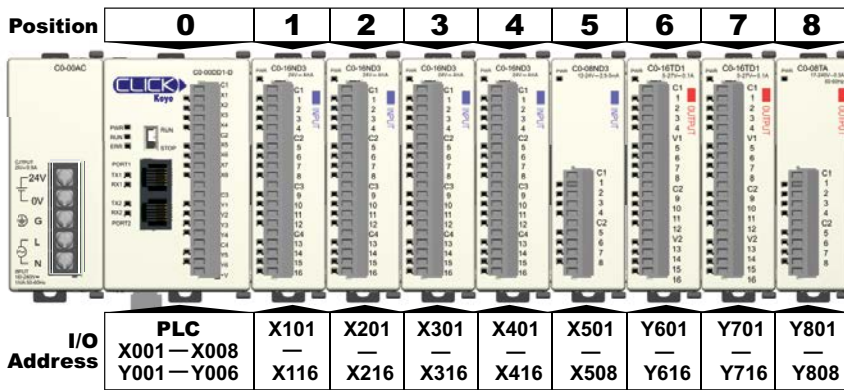

Addressing can be checked by using the System Configuration window from within the CLICK programming software. From the Setup pulldown menu, select System Configuration; otherwise, from the Navigation window select the Function tab, and under PLC configuration, double click on System Configuration.

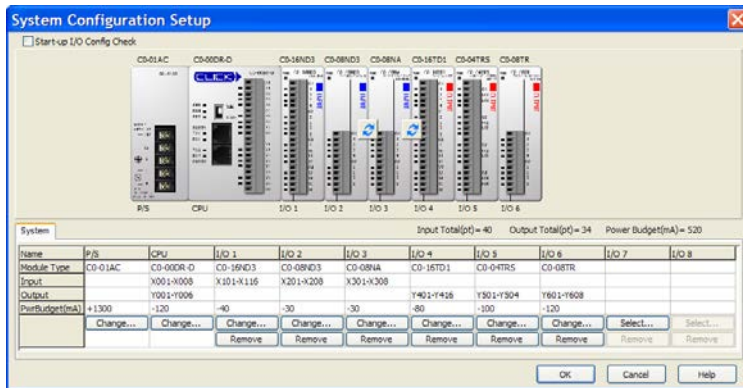

# PLC Operation

## Introduction

Achieving proper control of your equipment or process requires a thorough understanding of how the CLICK PLC controls all aspects of system operation. There are three main areas to understand before you create your application program:

- PLC Operating System – the PLC manages all aspects of system control. A quick overview of all the steps are provided in the next section.
- PLC Operating Modes – The two primary modes of operation are Stop mode and Run mode.
- PLC Memory Map – CLICK PLCs offer a wide variety of resources, such as timers, counters, inputs, etc. The Memory Map section shows the organization and availability of these data types.

## PLC Operating System

At powerup, the CLICK PLC initializes the internal electronic hardware. Memory initialization starts with examining the retentive memory settings. In general, the contents of retentive memory are preserved, and non-retentive memory is initialized to zero (unless otherwise specified).

After the one-time powerup tasks, the PLC begins the cyclical scan activity. The flowchart to the right shows how the tasks differ, based on the PLC mode and the existence of any errors. The “scan time” is defined as the average time around the task loop. Note that the PLC is always reading the inputs, even during Stop mode. This allows programming tools to monitor input status at any time.

The outputs are only updated in Run mode. In Stop mode, they are in the off state.

Error detection has two levels. Non-fatal errors are reported, but the PLC remains in its current mode. If a fatal error occurs, the PLC is forced into Stop mode and the outputs turn off.

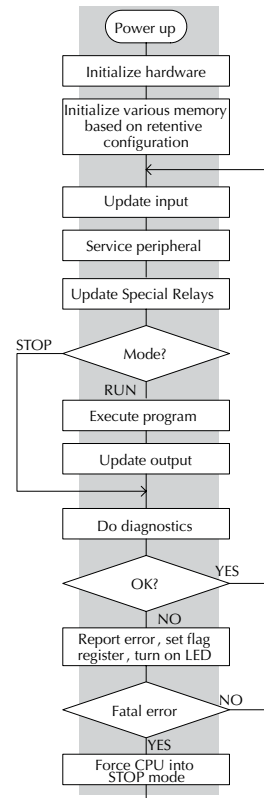

### PLC Operating Modes

#### Stop Mode

In Stop mode, the CLICK PLC does NOT execute the ladder logic program or update the output points. The primary use for Stop Mode is to enter or change a ladder logic program. You also use Stop mode to set up the PLC parameters, such as retentive memory areas, etc.

You can use CLICK Programming Software, or the CLICK PLC mode switch to place the PLC in Stop mode; however, the CLICK PLC mode switch will override the software mode condition. If the PLC mode switch is in the Stop position, the software is blocked from changing the PLC mode. When the PLC mode switch is in the Run position, the software may toggle the mode switch from Run to Stop at will.

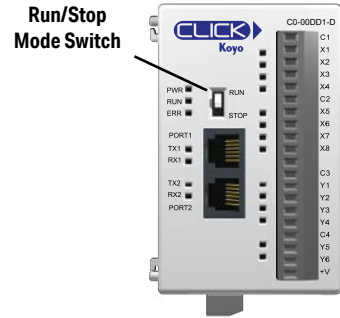

#### Run Mode

In Run mode, the PLC executes the application program and updates the I/O system. You can perform many operations during Run mode. Some of these include:

- Monitor and change I/O point status
- Change timer/counter preset values
- Change variable memory locations

The Run Mode can be divided into several key areas. For the vast majority of applications, some of these execution segments are more important than others. For example, you need to understand how the PLC updates the I/O points, handles forcing operations, and solves the application program. The remaining segments are not that important for most applications.

You can use CLICK Programming Software, or the CLICK PLC mode switch to place the PLC in Run mode.

Normal Run Mode Scan

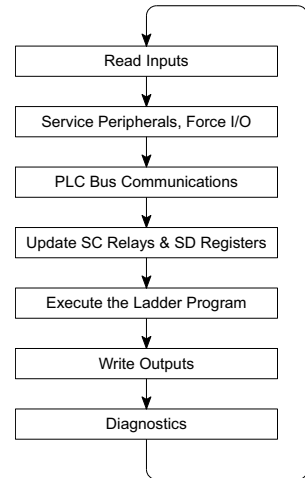

**WARNING:** Only authorized personnel fully familiar with all aspects of the application should make changes to the ladder logic program. Make sure you thoroughly consider the impact of any changes to minimize the risk of personal injury or damage to equipment.

## Read Inputs

The CLICK PLC reads the status of all inputs, then stores it in the image register. Input image register locations are designated with an X followed by a memory location. Image register data is used by the PLC when it solves the application program.

Of course, an input may change after the PLC has just read the inputs. Generally, the PLC scan time is measured in milliseconds. If you have an application that cannot wait until the next I/O update, you can use Immediate Instructions. These do not use the status of the input image register to solve the application program. The Immediate instructions immediately read the input status directly from the I/O modules. However, this lengthens the program scan since the PLC has to read the I/O point status again.

## Service Peripherals and Force I/O

After the CLICK PLC reads the inputs from the input modules, it reads any attached peripheral devices. This is primarily a communications service for any attached devices. For example, it would read a programming device to see if any input, output, or other memory type status needs to be modified. There are two basic types of forcing available with the CLICK PLC:

- Forcing from a peripheral – not a permanent force, good only for one scan
- Bit Override – holds the I/O point (or other bit) in the current state. Valid bits are X, Y, C, T and CT. (These memory types are discussed in more detail earlier in this chapter).

Forcing and Bit Override are done through the Data View Monitor.

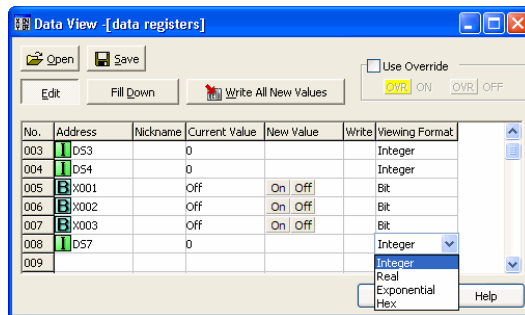

**Regular Forcing:** This type of forcing can temporarily change the status of a discrete bit. For example, you may want to force an input on, even though it is really off. This allows you to change the point status that was stored in the image register. This value will be valid until the image register location is written to during the next scan. This is primarily useful during testing situations when you need to force a bit on to trigger another event.

**Bit override:** This is a more forceful type of bit manipulation. When bit override is enabled, you can actually override the current status of a bit in the image register. This change will remain intact until you remove the override.



**WARNING:** Only authorized personnel fully familiar with all aspects of the application should make changes to the program. Make sure you thoroughly consider the impact of any changes to minimize the risk of personal injury or damage to equipment.

---

### Update System Control (SC) Relays and System Data (SD) Registers

The CLICK PLC units have system memory locations that hold this information. This portion of the execution cycle ensures these locations get updated on every scan. Also, there are several different system control relays, such as diagnostic relays, etc., that are also updated during this segment.

### Solve Application Program

The CLICK PLC evaluates each instruction in the application program during this segment of the scan cycle. The instructions define the relationship between the input conditions and the desired output response. The CLICK PLC uses the output image register area to store the status of the desired action for the outputs. Output image register locations are designated with a Y followed by a memory location. The actual outputs are updated during the write outputs segment of the scan cycle.

The internal control relays (C) and the data registers (DS, DD, DF and DH) are also updated in this segment.

You may recall that you can force various types of points in the system, discussed earlier in this chapter. If any I/O points or memory data have been forced, the output image register also contains this information.

### Write Outputs

Once the application program has solved the instruction logic and constructed the output image register, the CLICK PLC writes the contents of the output image register to the corresponding output points. Remember, the PLC also ensured that any forcing operation changes were stored in the output image register, so the forced points get updated with the status specified earlier.

### Diagnostics

During this part of the scan, the PLC performs all system diagnostics and other tasks such as calculating the scan time and resetting the watchdog timer. There are many different error conditions that are automatically detected and reported by the CLICK PLC. Chapter 6: *Troubleshooting* contains a listing of the various error codes with a description of the possible causes.

Probably one of the more important things that occurs during this segment is the scan time calculation and watchdog timer control. The CLICK PLC has a watchdog timer that stores the maximum time allowed for the PLC to complete the solve application part of the scan cycle. If this time is exceeded, the PLC will enter the Stop mode and turn off all outputs. An error is automatically reported. The default value of the watchdog timer is 200ms and can be adjusted between 5–10,000 ms. Refer to the online help available from the CLICK Programming Software, C0-PGMSW, for additional information in regards to the Watchdog Timer.

## Power Budgeting

### What is Power Budgeting?

There are two areas that need to be considered when determining the power required to operate a CLICK PLC system. The first area is the power required by the CLICK PLC, along with the internal logic side power that the PLC provides to its own I/O and any connected I/O modules that are powered through the PLC expansion port, plus any device, such as a C-more Micro-Graphic panel, that is powered through one of the PLC's communication ports.

The second area is the power required by all externally connected I/O devices. This should be viewed as the field side power required. The field side power is dependent on the voltage used for a particular input or output device as it relates to the wired I/O point, and the calculated load rating of the connected device

It is strongly recommended that the power source for the logic side be separate from the power source for the field side to help eliminate possible electrical noise.

Be aware that the CLICK PLC unit sinking DC output points require a sustained voltage to work with their output drivers. This includes the C0-00DD1-D PLC, and the C0-08TD1 & C0-16TD1 output modules. It is recommended that this voltage be provided from the field side power source.

The CLICK PLC operates from a 24VDC power source. The 24VDC power source can be provided by an optional CLICK PLC unit power supply (C0-00AC or C0-01AC), or a standard industrial 24VDC power supply as offered by AutomationDirect.



**CLICK 24VDC Power Supply**  
C0-00AC or C0-01AC



**Alternative 24VDC Power Supply**  
Example: PSP24-DC12-1

Visit [www.automationdirect.com](http://www.automationdirect.com) for the complete line.

The power source for the connected I/O devices is dependent on the voltage rating of the devices and the type of CLICK I/O module that is being used.

Power Budgeting requires the calculation of the total current that the 24VDC power source needs to provide to CLICK PLC unit logic side, and also a separate calculation of the total current required from all devices operating from the field side of the CLICK PLC system.

Refer to the following pages which includes tables listing the CLICK PLC and I/O module current requirements, plus a power budgeting example.

### Power Budget Calculation

The following table shows the current consumption required for both the logic side and field side of the CLICK units.

PLC Current Consumption (mA)		
Part Number	Power Budget 24VDC (logic side)	External 24VDC (field side)
<b>Basic PLC Units</b>		
C0-00DD1-D	120	60
C0-00DD2-D	120	0
C0-00DR-D	120	0
C0-00AR-D	120	0
<b>Standard PLC Units</b>		
C0-01DD1-D	140	60
C0-01DD2-D	140	0
C0-01DR-D	140	0
C0-01AR-D	140	0
<b>Analog PLC Units</b>		
C0-02DD1-D	140	60
C0-02DD2-D	140	0
C0-02DR-D	140	0
<b>Ethernet Basic PLC Units</b>		
C0-10DD1E-D	120	60
C0-10DD2E-D	120	0
C0-10DRE-D	120	0
C0-10ARE-D	120	0
<b>Ethernet Standard PLC Units</b>		
C0-11DD1E-D	140	60
C0-11DD2E-D	140	0
C0-11DRE-D	140	0
C0-11ARE-D	140	0
<b>Ethernet Analog PLC Units</b>		
C0-12DD1E-D	140	60
C0-12DD2E-D	140	0
C0-12DRE-D	160	0
C0-12ARE-D	160	0
C0-12DD1E-1-D	140	60
C0-12DD2E-1-D	140	0
C0-12DRE-1-D	160	0
C0-12ARE-1-D	160	0
C0-12DD1E-2-D	140	60
C0-12DD2E-2-D	140	0
C0-12DRE-2-D	160	0
C0-12ARE-2-D	140	0

I/O Module Current Consumption (mA)		
Part Number	Power Budget 24VDC (logic side)	External 24VDC (field side)
<b>Discrete Input Modules</b>		
C0-08ND3	30	0
C0-08ND3-1	30	0
C0-16ND3	40	0
C0-08NE3	30	0
C0-16NE3	40	0
C0-08NA	30	0
<b>Discrete Output Modules</b>		
C0-08TD1	50	15
C0-08TD2	50	0
C0-16TD1	80	100
C0-16TD2	80	0
C0-08TA	80	0
C0-04TRS	100	0
C0-04TRS-10	120	0
C0-08TR	100	0
C0-08TR-3	90	0
<b>Discrete Combo I/O Modules</b>		
C0-16CDD1	80	50
C0-16CDD2	80	0
C0-08CDR	80	0
<b>Specialty Modules</b>		
C0-08SIM	50	0
C0-04POT	30	0
<b>Analog Input Modules</b>		
C0-04AD-1	20	65
C0-04AD-2	23	65
C0-04RTD	25	0
C0-04THM	25	0
<b>Analog Output Modules</b>		
C0-04DA-1	20	145
C0-04DA-2	20	85
<b>Analog Combo I/O Modules</b>		
C0-4AD2DA-1	25	75
C0-4AD2DA-2	20	65
<b>C-more Micro-Graphic Panel (Monochrome only)</b>		
All p/n	90	0

### Power Budget Example

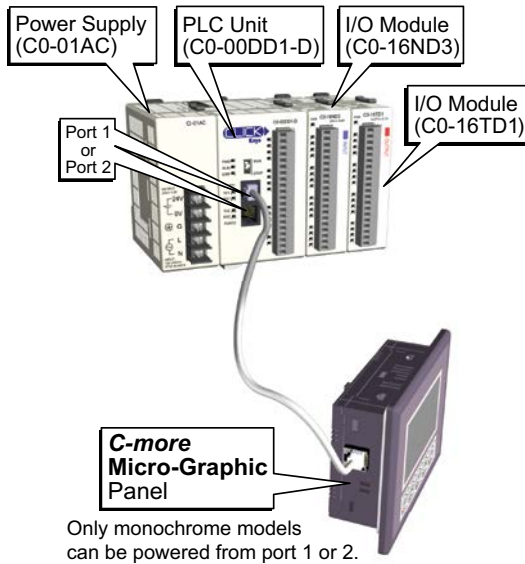

Add the current consumption for each module in the system as shown in this example.

Current Consumption (mA)		
Part Number	Power Budget 24VDC (logic side)	External 24VDC (field side)
C0-00DD1-D	120	60
C0-16ND3	40	0
C0-16TD1	80	100
C-more Micro	90	0
<b>Total:</b>	<b>330</b>	<b>160*</b>

\* Plus calculated load of connected I/O devices.

### Power Budgeting using the CLICK Programming Software

The following example shows the logic side current consumption as calculated in the System Configuration Setup section of the CLICK Programming Software. Based on the amperage rating of the power supply selected in the first column, your power budget is calculated by subtracting each consecutive module's power consumption from the total available power budget. If you exceed the maximum allowable power consumption, the power budget row fills in red.

Power budget row turns red if maximum allowable power consumption is exceeded for the power supply selected.

Name	P/S	CPU	I/O 1	I/O 2	I/O 3	I/O 4	I/O 5	I/O 6	I/O 7	I/O 8
Module Type	C0-01AC	C0-01DD2-D	C0-08ND3	C0-08NE3	C0-16NE3	C0-16TD1	C0-04TR5	C0-08TR		
Input(Y)		X001-X008	X101-X108	X201-X208	X301-X316					
Output(Y)		Y001-Y006				Y401-Y416	Y501-Y504	Y601-Y604		
PowerBudget(mA)	+1200	-140	-30	-30	-40	-80	-100	-100		

## General Specifications

### General Specifications (all CLICK PLC units)

The following general specifications apply to all CLICK PLC units, optional I/O modules, and optional power supply products. Please refer to the appropriate I/O temperature derating charts under both the PLC and I/O module specifications to determine best operating conditions based on the ambient temperature of your particular application.

General Specifications	
<b>Power Input Voltage Range</b>	20–28 VDC
<b>Maximum Power Consumption</b>	5W (No 5V use from communication port)
<b>Maximum Inrush Current</b>	30A (less than 1ms)
<b>Acceptable External Power Drop</b>	Max 10ms
<b>Operating Temperature</b>	Analog units, analog combo I/O modules only: 32°F to 140°F (0°C to 60°C); All other modules: 32°F to 131°F (0°C to 55°C), IEC 60068-2-14 (Test Nb, Thermal Shock)
<b>Storage Temperature</b>	–4°F to 158°F (–20°C to 70°C) IEC 60068-2-1 (Test Ab, Cold) IEC 60068-2-2 (Test Bb, Dry Heat) IEC 60068-2-14 (Test Na, Thermal Shock)
<b>Ambient Humidity</b>	30% to 95% relative humidity (non-condensing)
<b>Altitude</b>	Up to 2,000m
<b>Environmental Air</b>	No corrosive gases The level for the environmental pollution is 2 (UL840)
<b>Vibration</b>	MIL STD 810C, Method 514.2 IEC60068-2-27, Category [f], Procedure[VIII] JIS C60068-2-27 (Sine wave vibration test)
<b>Shock</b>	MIL STD 810C, Method 516.2 IEC60068-2-27 JIS C60068-2-27, Category [f], Procedure[VIII]
<b>Noise Immunity</b>	<EN61131-2> EN61000-4-2 (ESD) EN61000-4-3 (RFI) EN61000-4-4 (FTB) EN61000-4-5 (Surge) EN61000-4-6 (Conducted) EN61000-4-8 (Power frequency magnetic field immunity) Comply with NEMA ICS3-304 Impulse noise 1µs, 1000V RFI: No interference measured at 150MHz and 450MHz (5w/15cm)
<b>Emissions</b>	EN55011:1998 Class A; EN61000-6-4:2007+A1:2011
<b>Agency Approvals</b>	UL508 (File No. E157382, E316037); CE (EN61131-2); CUL Canadian C22.2
<b>Other</b>	RoHS 2011/65/EU Amendment (EU)2015/863

# PLC Unit Specifications

## Common Specifications

Basic, Standard and Analog PLC Unit Specifications			
	Basic PLC	Standard PLC	Analog PLC
Control Method	Stored Program/Cyclic execution method	Stored Program/Cyclic execution method	Stored Program/Cyclic execution method
I/O Numbering System	Fixed in Decimal	Fixed in Decimal	Fixed in Decimal
Ladder Memory (steps)	8000	8000	8000
Total Data Memory (words)	8000	8000	8000
Contact Execution (boolean)	< 0.6us	< 0.6us	< 0.6us
Typical Scan (1k boolean)	1–2 ms	1–2 ms	1–2 ms
RLL Ladder Style Programming	Yes	Yes	Yes
Run Time Edits	No	No	No
Scan	Variable / fixed	Variable / fixed	Variable / fixed
CLICK Programming Software for Windows	Yes	Yes	Yes
Built-in Communication Ports	Yes (two RS-232 ports)	Yes (two RS-232 ports and one RS-485 port)	Yes (two RS-232 ports and one RS-485 port)
FLASH Memory	Standard on PLC	Standard on PLC	Standard on PLC
Protocol	Protocols: Modbus RTU (master/slave) and ASCII (in/out)		
Built-in Discrete I/O points	8 inputs, 6 outputs	8 inputs, 6 outputs	4 inputs, 4 outputs
Built-in Analog I/O Channels	No	No	2 inputs, 2 outputs
Number of Instructions Available	21	21	21
Control Relays	2000	2000	2000
System Control Relays	1000	1000	1000
Timers	500	500	500
Counters	250	250	250
Interrupt	Yes (external: 8 / timed: 4)	Yes (external: 8 / timed: 4)	Yes (external: 4 / timed: 4)
Subroutines	Yes	Yes	Yes
For/Next Loops	Yes	Yes	Yes
Math (Integer and Hex)	Yes	Yes	Yes
Drum Sequencer Instruction	Yes	Yes	Yes
Internal Diagnostics	Yes	Yes	Yes
Password Security	Yes	Yes	Yes
System Error Log	Yes	Yes	Yes
User Error Log	No	No	No
Memory Backup	Super Capacitor	Super Capacitor + Battery	Super Capacitor + Battery
Battery Backup	No	Yes (battery part # D2-BAT-1)	Yes (battery part # D2-BAT-1)
Calendar/Clock	No	Yes	Yes
I/O Terminal Block Replacement	AutomationDirect p/n C0-16TB	AutomationDirect p/n C0-16TB	AutomationDirect p/n C0-16TB
Communication Port & Terminal Block Replacement	N/A	AutomationDirect p/n C0-3TB	AutomationDirect p/n C0-3TB
24VDC Power Terminal Block Replacement	AutomationDirect p/n C0-4TB	AutomationDirect p/n C0-4TB	AutomationDirect p/n C0-4TB

## PLC Unit Specifications, cont'd

Ethernet Basic, Standard and Analog PLC Unit Specifications			
	Ethernet Basic PLC	Ethernet Standard PLC	Ethernet Analog PLC
Control Method	Stored Program/Cyclic Execution Method		
I/O Numbering System	Fixed in Decimal	Fixed in Decimal	Fixed in Decimal
Ladder Memory (steps)	8000	8000	8000
Total Data Memory (words)	8000	8000	8000
Contact Execution (Boolean)	< 0.2 $\mu$ s	< 0.2 $\mu$ s	< 0.2 $\mu$ s
Typical Scan (1K Boolean)	< 1ms	< 1ms	< 1ms
RLL Ladder Style Programming	Yes	Yes	Yes
Run Time Edits	Yes	Yes	Yes
Scan	Variable / fixed	Variable / fixed	Variable / fixed
CLICK Programming Software for Windows	Yes	Yes	Yes
Built-in Communication Ports	Yes (one Ethernet port and one RS-232 port)	Yes (one Ethernet port, one RS-232 port and one RS-485 port)	Yes (one Ethernet port, one RS-232 port and one RS-485 port)
Protocol	Modbus RTU (master/slave) and ASCII (in/out), Modbus TCP (client server), EtherNet/IP Implicit and Explicit (adapter server)		
FLASH Memory	Standard on PLC	Standard on PLC	Standard on PLC
Built-in Discrete I/O points	8 inputs, 6 outputs	8 inputs, 6 outputs	4 inputs, 4 outputs
Built-in Analog I/O Channels	No	No	2 inputs, 2 outputs or 4 inputs, 2 outputs
Number of High-Speed Input Points	4	8	4
Number of High-Speed Counters	4	6	4
PID Control Loops	8	8	8
Number of Instructions Available	21	21	21
Control Relays	2000	2000	2000
System Control Relays	1000	1000	1000
Timers	500	500	500
Counters	250	250	250
Interrupts	Yes (external: 8 / timed: 4)	Yes (external: 8 / timed: 4)	Yes (external: 4 / timed: 4)
Subroutines	Yes	Yes	Yes
For/Next Loops	Yes	Yes	Yes
Math (Integer and Hex)	Yes	Yes	Yes
Drum Sequencer Instruction	Yes	Yes	Yes
Internal Diagnostics	Yes	Yes	Yes
Password Security	Yes	Yes	Yes
System Error Log	Yes	Yes	Yes
User Error Log	No	No	No
Memory Backup	Super Capacitor + Battery		
Battery Backup	Yes (battery part # D2-BAT-1)		
Calendar/Clock	Yes	Yes	Yes
I/O Terminal Block Replacement	AutomationDirect p/n C0-16TB		
Communication Port & Terminal Block Replacement	N/A	AutomationDirect p/n C0-3TB	AutomationDirect p/n C0-3TB
24VDC Power Terminal Block Replacement	AutomationDirect p/n C0-4TB		

## PLC LED Status Indicators

Basic PLC

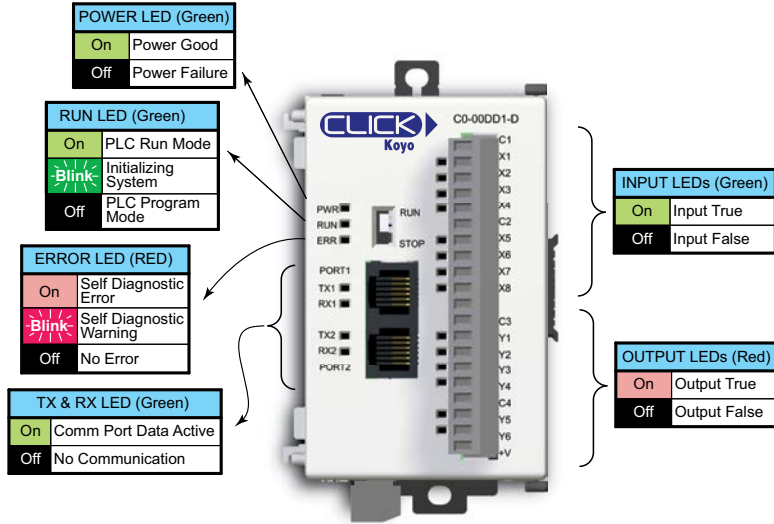

Standard PLC

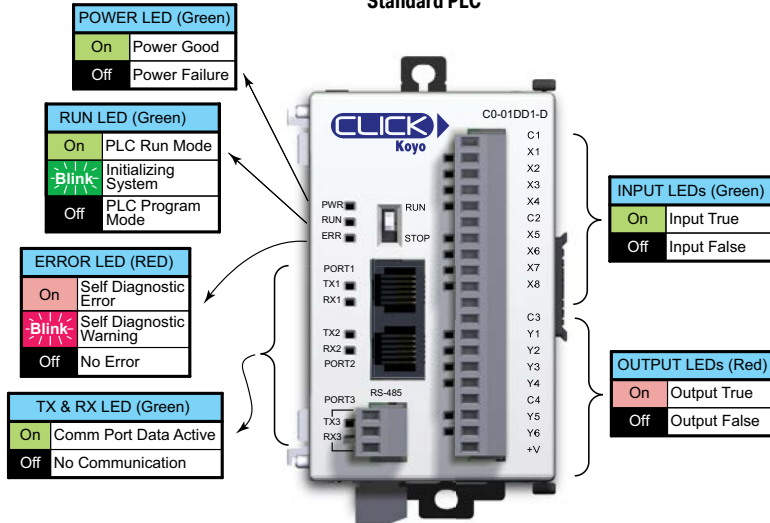

PLC LED Status Indicators, (cont'd)

Analog PLC

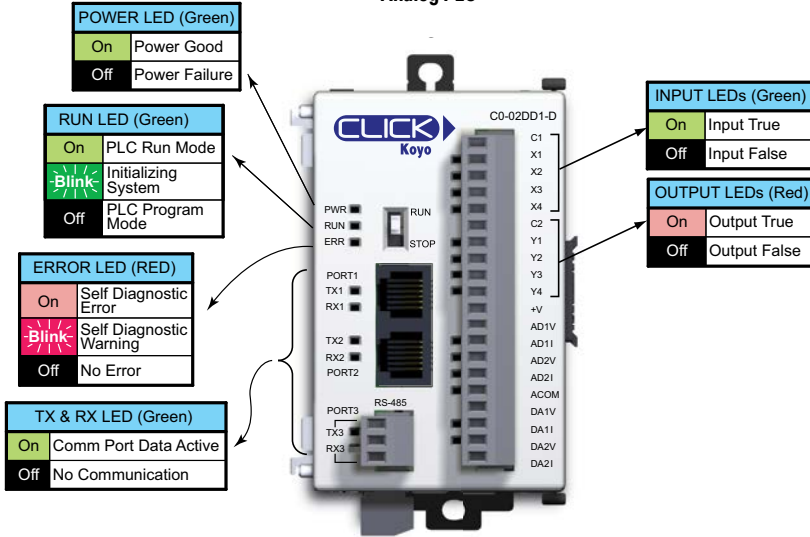

Ethernet Basic PLC

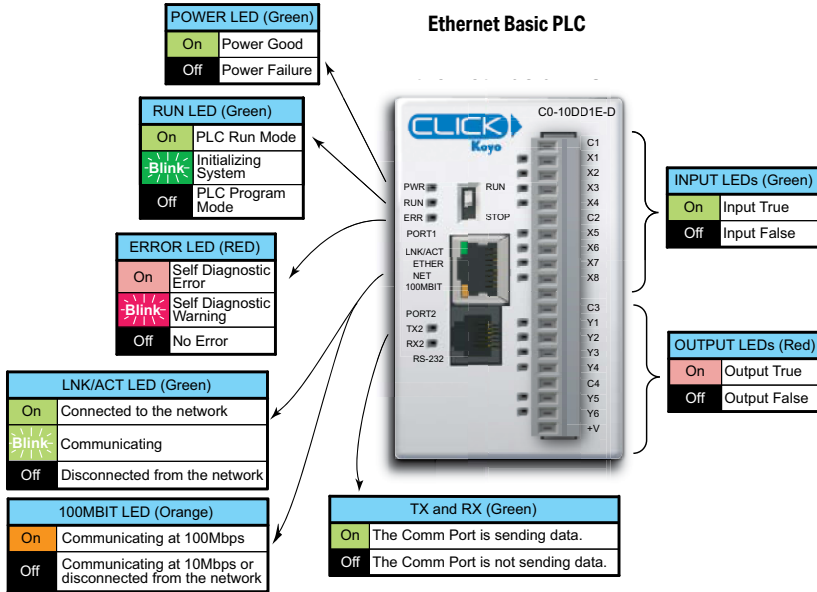

PLC LED Status Indicators, (cont'd)

Ethernet Standard PLC

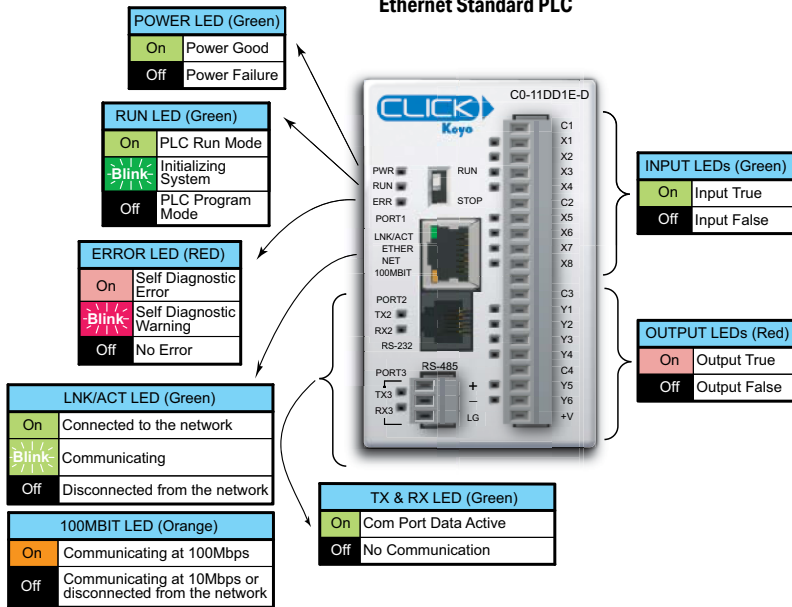



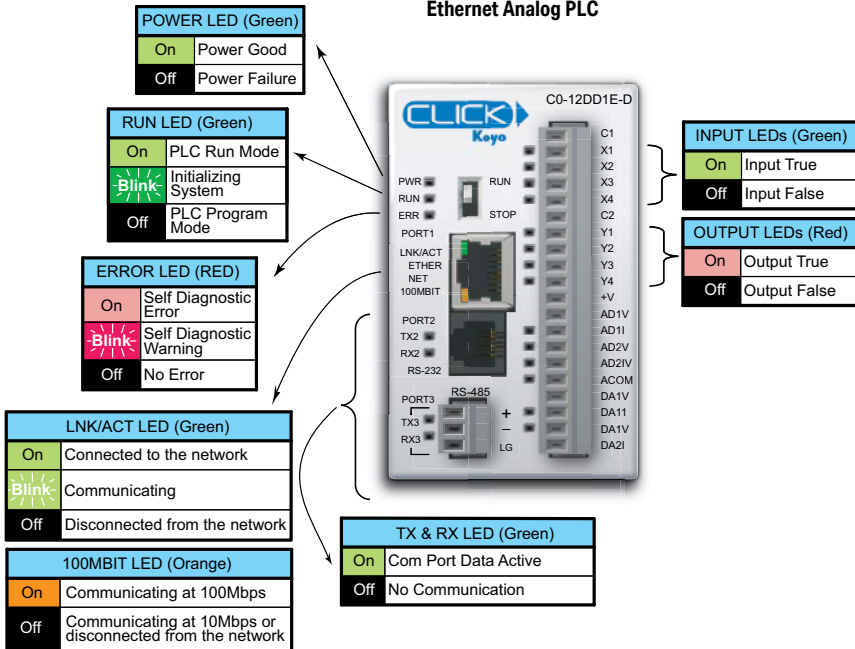







Ethernet Analog PLC



### Memory Map

All of the CLICK PLC units support the same memory map. The CLICK PLC uses decimal numbers for the memory addressing. See pages 2-15 and 2-16 for the definitions of each data type and memory type.

Memory Type	Symbol	Data Type	S/W Icon	Range
Input Point	X	Bit		X001 – X816
Output Point	Y			Y001 – Y816
Control Relay	C			C1 – C2000
Timer	T			T1 – T500
Counter	CT			CT1 – CT250
System Control Bit	SC			SC1 – SC1000
Data Register	DS	Integer		DS1 – DS4500
	DD	Integer2		DD1 – DD1000
	DH	HEX		DH1 – DH500
	DF	Floating Point		DF1 – DF500
Input Register	XD	HEX		XD0 – XD8
Output Register	YD			YD0 – YD8
Timer Register	TD	Integer		TD1 – TD500
Counter Register	CTD	Integer2		CTD1 – CTD250
System Data Register	SD	Integer		SD1 – SD1000
Text	TXT	Text		TXT1 – TXT1000

## CLICK Software PID Specifications

PID Specifications	
PID maximum number of loops	8
Required Memory	40 C bits, 15 DS registers, 25 DF registers
Control Algorithm	Position
Control Loop Action	Direct-acting or Reverse-acting
Error Term	Linear or Squared
Error Dead band	Configurable
Proportional Gain	0.01–10000
Reset Time (Integral)	0.01–6000
Derivative Gain	0.0–6000
Sampling rate	100ms to 30000ms
Loop Calculation	PID or PI
PV Filter	Configurable
Set Point	Maximum and minimum values can be set
Control Output	Maximum and minimum values can be set
Derivative Gain Limit	Configurable
Bias Freeze (Anti-Windup)	Yes
Bumpless Transfer	2 Modes
Pulse Width Modulation (PWM)Output	Yes, up to 600 second period
Auto Tuning	Ziegler-Nichols Limit Cycle
Alarms	
PV Alarm	PV alarm value can be set at Low-low, Low, High, High-high condition
Deviation Alarm	Specify alarms for two ranges of PV deviation from the setpoint value
PV Rate of Change	Detect when PV exceeds a rate of change limit you specify

### CLICK PLC Hardware/Software Compatibility

The table below shows the most recent software and hardware versions required for each hardware and feature release

CLICK PLC Features Software Compatibility						
CPU Type	Part Number	Minimum CLICK Software Version				
		Hardware	High-Speed Inputs	EtherNet/IP	PID	I/O Modules
Basic	C0-00DD1-D	v1.00	N/A	N/A	N/A	N/A
	C0-00DD2-D					
	C0-00DR-D					
	C0-00AR-D					
Standard	C0-01DD1-D	v1.20	N/A	N/A	N/A	N/A
	C0-01DD2-D					
	C0-01DR-D					
	C0-01AR-D					
Analog	C0-02DD1-D (before SN 171208001)	v1.12	N/A	N/A	N/A	N/A
	C0-02DD1-D (SN 171208001-25Z319999)	v2.10				
	C0-02DD1-D (SN 260100001 or later)	v2.61				
	C0-02DD2-D (before SN 174018001)	v1.12				
	C0-02DD2-D (SN 174018001-25Z319999)	v2.10				
	C0-02DD2-D (SN 260100001 or later)	v2.61				
	C0-02DR-D (before SN 173158001)	v1.12				
	C0-02DR-D (SN 173158001-25Z319999)	v2.10				
	C0-02DR-D (SN 260100001 or later)	v2.61				
Ethernet Basic	C0-10DD1E-D	v2.00	v2.30	v2.40	v2.50	N/A
	C0-10DD2E-D					
	C0-10DRE-D		N/A			
	C0-10ARE-D					
Ethernet Standard	C0-11DD1E-D	v2.00	v2.30	v2.40	v2.50	N/A
	C0-11DD2E-D					
	C0-11DRE-D		N/A			
	C0-11ARE-D					

Table continued on next page.

## CLICK PLC Hardware/Software Compatibility (continued)

CLICK PLC Features Software Compatibility (Continued)						
		Minimum CLICK Software Version				
CPU Type	Part Number	Hardware	High-Speed Inputs	EtherNet/IP	PID	I/O Modules
Ethernet Analog	C0-12DD1E-D	v2.20	v2.30	v2.40	v2.50	N/A
	C0-12DD2E-D					
	C0-12DRE-D		N/A			
	C0-12ARE-D					
	C0-12DD1E-1-D		v2.30			
	C0-12DD2E-1-D					
	C0-12DRE-1-D		N/A			
	C0-12ARE-1-D					
	C0-12DD1E-2-D		v2.30			
	C0-12DD2E-2-D					
	C0-12DRE-2-D		N/A			
C0-12ARE-2-D						

CLICK PLC Module Features Software Compatibility						
		Minimum CLICK Software Version				
	Part Number	Hardware	High-Speed Inputs	EtherNet/IP	PID	I/O Modules
Relay Modules	C0-04TRS-10	N/A	N/A	N/A	N/A	v2.60
	C0-08TR-3					
Simulator Modules	C0-08SIM					v3.70
	C0-04POT					

# Basic PLC Unit Specifications

## C0-00DD1-D – 8 DC Input/6 Sinking DC Output Micro PLC

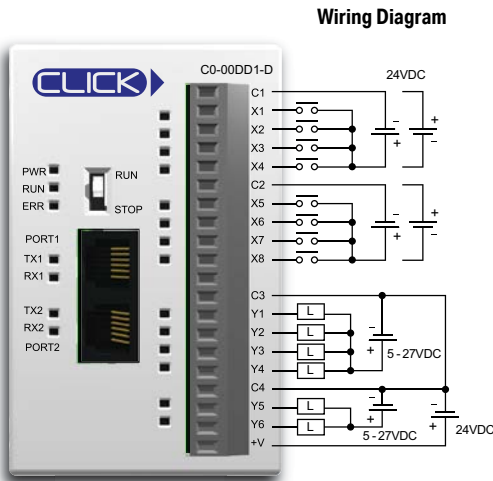

Built-in I/O Specifications - Inputs	
Inputs per Module	8 (Sink/Source)
Operating Voltage Range	24VDC
Input Voltage Range	21.6-26.4 VDC
Input Current	X1-2: Typ 5mA @ 24VDC X3-8: Typ 4mA @ 24VDC
Maximum Input Current	X1-2: 6.0 mA @ 26.4 VDC X3-8: 5.0 mA @ 26.4 VDC
Input Impedance	X1-2: 4.7 kΩ @ 24VDC X3-8: 6.8 kΩ @ 24VDC
ON Voltage Level	X1-2: > 19VDC X3-8: > 19VDC
OFF Voltage Level	X1-2: < 4VDC X3-8: < 7VDC
Minimum ON Current	X1-2: 4.5 mA X3-8: 3.5 mA
Maximum OFF Current	X1-2: 0.1 mA X3-8: 0.5 mA
OFF to ON Response	X1-2: Typ 5μs Max 20μs X3-8: Typ 2ms Max 10ms
ON to OFF Response	X1-2: Typ 5μs Max 20μs X3-8: Typ 3ms Max 10ms
Status Indicators	Logic Side (8 points, green LED)
Commons	2 (4 points/common) Isolated

General Specifications	
Current Consumption at 24VDC	120mA
Terminal Block Replacement Part No.	C0-16TB
Weight	5.0 oz (140g)

Equivalent Input Circuit

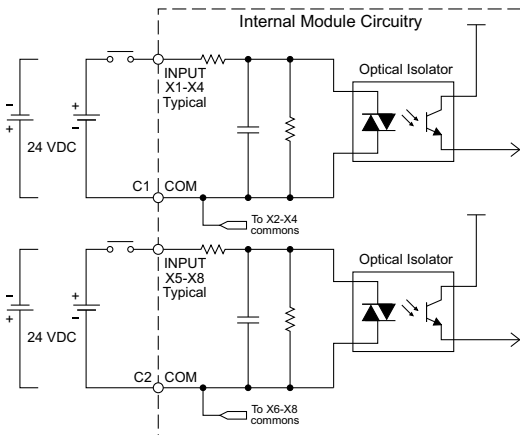

C0-00DD1-D Temperature Derating Chart

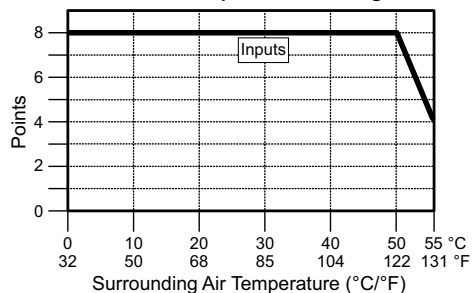

C0-00DD1-D – 8 DC Input/6 Sinking DC Output Micro PLC (continued)

Built-in I/O Specifications - Outputs	
Outputs per Module	6 (Sink)
Operating Voltage Range	5-27 VDC
Output Voltage Range	4-30 VDC
Maximum Output Current	0.1 A/point; C3: 0.4 A/common, C4: 0.2 A/common
Minimum Output Current	0.2 mA
Maximum Leakage Current	0.1 mA @ 30.0 VDC
On Voltage Drop	0.5 VDC @ 0.1 A
Maximum Inrush Current	150mA for 10ms
OFF to ON Response	Y1: typ 5µs; Max 20µs Y2-6: < 0.5 ms
ON to OFF Response	Y1: typ 5µs; Max 20µs Y2-6: < 0.5 ms
Status Indicators	Logic Side (6 points, red LED)
Commons	2 (4 points/com & 2 points/com)
External DC Power Required	20-28 VDC Maximum @ 60mA (All Points On)

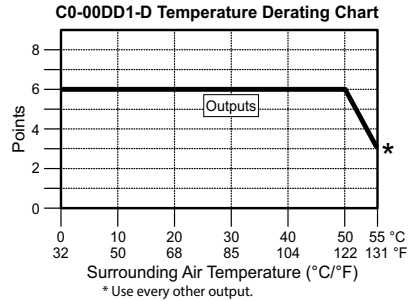

Equivalent Output Circuit

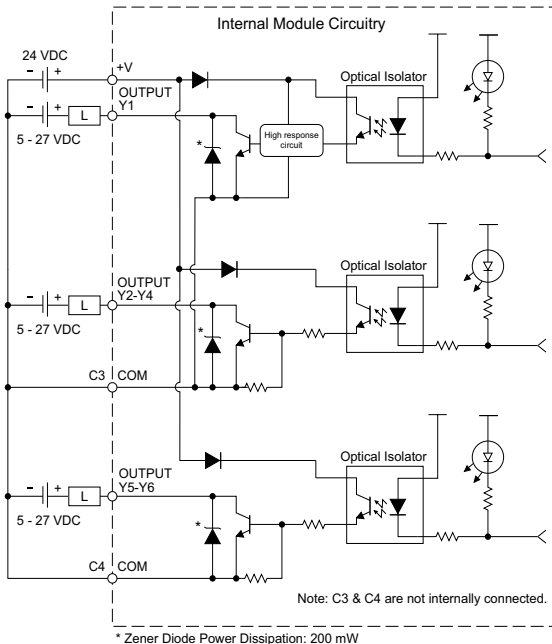

ZIPLink Pre-Wired PLC Connection Cables and Modules for CLICK PLC

- 20-pin connector cable
- ZL-C0-CBL20 (0.5 m length)
- ZL-C0-CBL20-1 (1.0 m length)
- ZL-C0-CBL20-2 (2.0 m length)



- ZL-RTB20
- 20-pin feed-through connector module



C0-00DD2-D – 8 DC Input/6 Sourcing DC Output Micro PLC

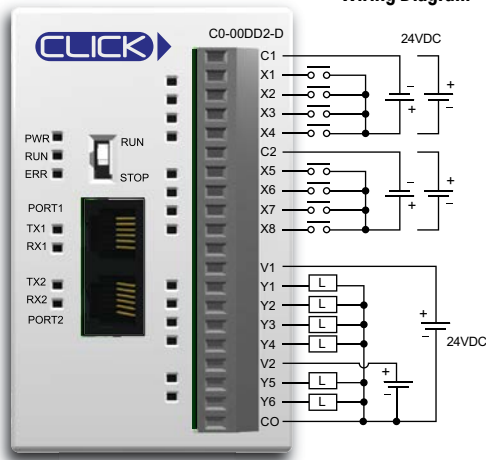

Built-in I/O Specifications - Inputs	
Inputs per Module	8 (Sink/Source)
Operating Voltage Range	24VDC
Input Voltage Range	21.6-26.4 VDC
Input Current	X1-2: Typ 5mA @ 24VDC X3-8: Typ 4mA @ 24VDC
Maximum Input Current	X1-2: 6.0 mA @ 26.4 VDC X3-8: 5.0 mA @ 26.4 VDC
Input Impedance	X1-2: 4.7 kΩ @ 24VDC X3-8: 6.8 kΩ @ 24VDC
ON Voltage Level	X1-2: > 19VDC X3-8: > 19VDC
OFF Voltage Level	X1-2: < 4VDC X3-8: < 7VDC
Minimum ON Current	X1-2: 4.5 mA X3-8: 3.5 mA
Maximum OFF Current	X1-2: 0.1 mA X3-8: 0.5 mA
OFF to ON Response	X1-2: Typ 5μs Max 20μs X3-8: Typ 2ms Max 10ms
ON to OFF Response	X1-2: Typ 5μs Max 20μs X3-8: Typ 3ms Max 10ms
Status Indicators	Logic Side (8 points, green LED)
Commons	2 (4 points/common) Isolated

General Specifications	
Current Consumption at 24VDC	120mA
Terminal Block Replacement Part No.	C0-16TB
Weight	5.0 oz (140g)

Equivalent Input Circuit

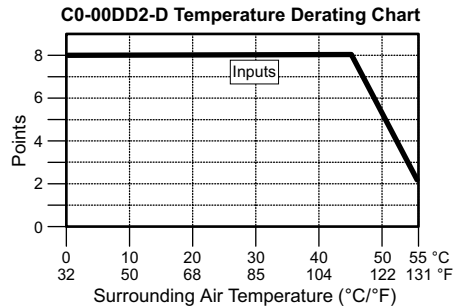
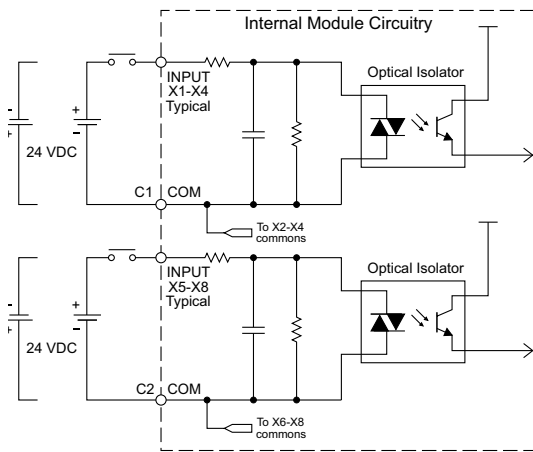

C0-00DD2-D – 8 DC Input/6 Sourcing DC Output Micro PLC (continued)

Built-in I/O Specifications - Outputs	
Outputs per Module	6 (Source)
Operating Voltage Range	24VDC
Output Voltage Range	19.2–30 VDC
Maximum Output Current	0.1 A/point, 0.6 A/common
Minimum Output Current	0.2 mA
Maximum Leakage Current	0.1 mA @ 30VDC
On Voltage Drop	Y1: 1.0 VDC @ 0.1 A Y2-6: 0.5 VDC @ 0.1 A
Maximum Inrush Current	150mA for 10ms
OFF to ON Response	Y1: typ 5 $\mu$ s; max 20 $\mu$ s Y2-6: < 0.5 ms
ON to OFF Response	Y1: typ 5 $\mu$ s; max 20 $\mu$ s Y2-6: < 0.5 ms
Status Indicators	Logic Side (6 points, red LED)
Commons	1 (6 points/common)

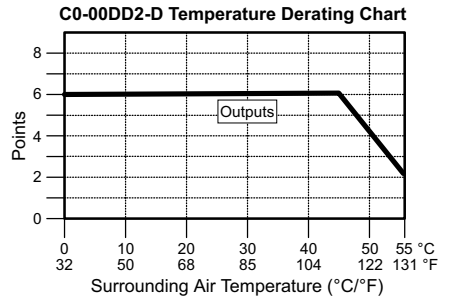

Equivalent Output Circuit

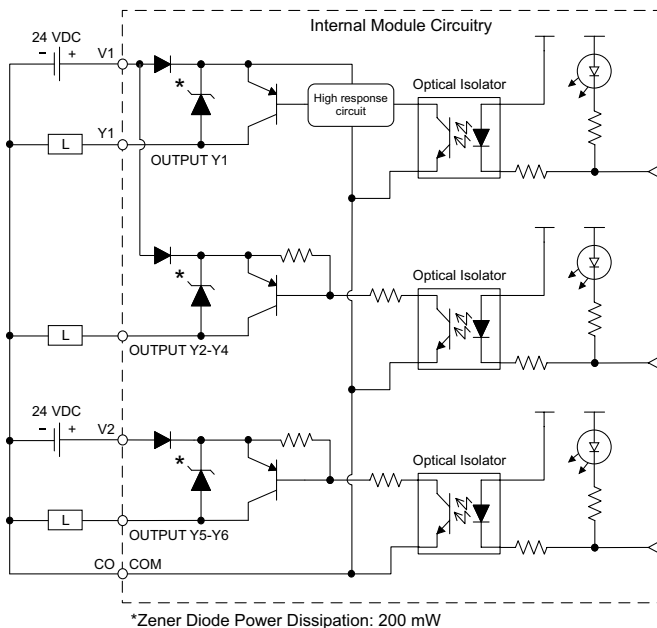

Z/PLink Pre-Wired PLC Connection Cables and Modules for CLICK PLC

- 20-pin connector cable
- ZL-C0-CBL20 (0.5 m length)
- ZL-C0-CBL20-1 (1.0 m length)
- ZL-C0-CBL20-2 (2.0 m length)



- ZL-RTB20
- 20-pin feed-through connector module



## C0-00DR-D – 8 DC Input/6 Relay Output Micro PLC

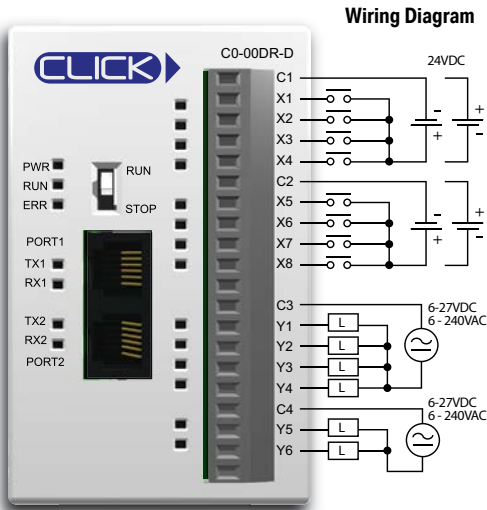

Built-in I/O Specifications - Inputs	
<b>Inputs per Module</b>	8 (Sink/Source)
<b>Operating Voltage Range</b>	24VDC
<b>Input Voltage Range</b>	21.6-26.4 VDC
<b>Input Current</b>	X1-2: Typ 5mA @ 24VDC X3-8: Typ 4mA @ 24VDC
<b>Maximum Input Current</b>	X1-2: 6.0 mA @ 26.4 VDC X3-8: 5.0 mA @ 26.4 VDC
<b>Input Impedance</b>	X1-2: 4.7 kΩ @ 24VDC X3-8: 6.8 kΩ @ 24VDC
<b>ON Voltage Level</b>	X1-2: > 19VDC X3-8: > 19VDC
<b>OFF Voltage Level</b>	X1-2: < 4VDC X3-8: < 7VDC
<b>Minimum ON Current</b>	X1-2: 4.5 mA X3-8: 3.5 mA
<b>Maximum OFF Current</b>	X1-2: 0.1 mA X3-8: 0.5 mA
<b>OFF to ON Response</b>	X1-2: Typ 5μs Max 20μs X3-8: Typ 2ms Max 10ms
<b>ON to OFF Response</b>	X1-2: Typ 5μs Max 20μs X3-8: Typ 3ms Max 10ms
<b>Status Indicators</b>	Logic Side (8 points, green LED)
<b>Commons</b>	2 (4 points/common) Isolated

General Specifications	
<b>Current Consumption at 24VDC</b>	120mA
<b>Terminal Block Replacement Part No.</b>	C0-16TB
<b>Weight</b>	5.6 oz (160g)

### Equivalent Input Circuit

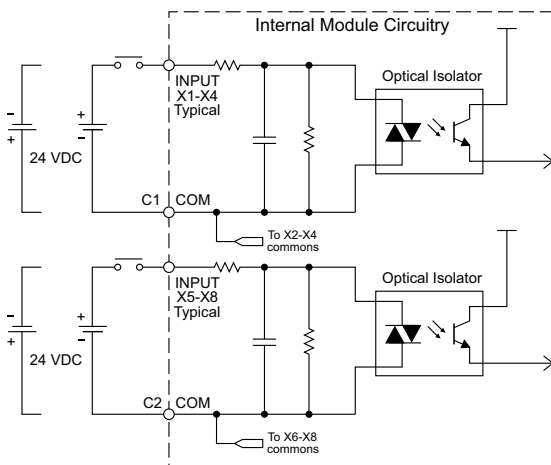

C0-00DR-D Temperature Derating Chart

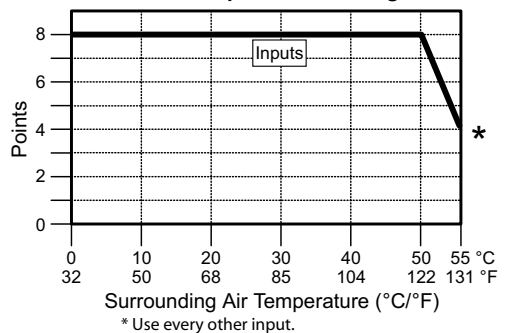

C0-00DR-D – 8 DC Input/6 Relay Output Micro PLC (continued)

Built-in I/O Specifications - Outputs	
Outputs per Module	6
Operating Voltage Range	6-240 VAC (47-63 Hz), 6-27 VDC
Output Voltage Range	5-264 VAC (47-63 Hz), 5-30 VDC
Output Type	Relay, form A (SPST)
Maximum Current	1 A/point; C3: 4A/common, C4: 2A/common
Minimum Load Current	5mA @ 5VDC
Maximum Inrush Current	3A for 10ms
OFF to ON Response	< 15ms
ON to OFF Response	< 15ms
Status Indicators	Logic Side (6 points, red LED)
Commons	2 (4 points/com & 2 points/com) Isolated

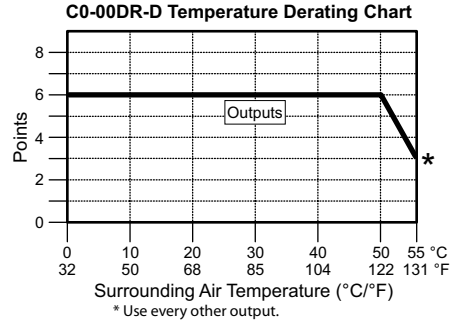

Typical Relay Life (Operations) at Room Temperature	
Voltage & Load Type	Relay Life
30VDC, 1A Resistive	300,000 cycles
30VDC, 1A Solenoid	50,000 cycles
250VAC, 1A Resistive	500,000 cycles
250VAC, 1A Solenoid	200,000 cycles
ON to OFF = 1 cycle	

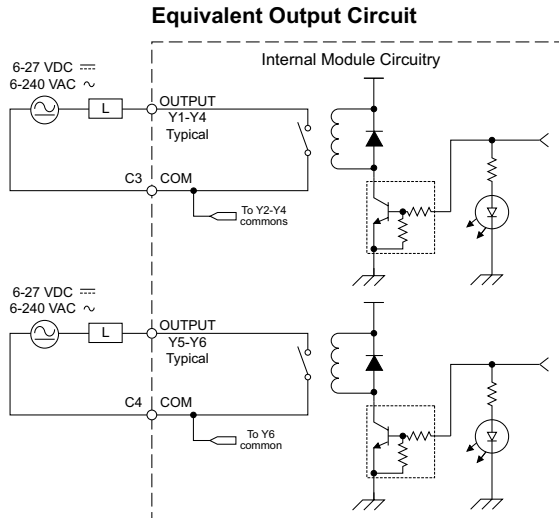

**ZIPLink Pre-Wired PLC Connection Cables and Modules for CLICK PLC**

- 20-pin connector cable
- ZL-C0-CBL20 (0.5 m length)
- ZL-C0-CBL20-1 (1.0 m length)
- ZL-C0-CBL20-2 (2.0 m length)



**ZL-RTB20**  
20-pin feed-through connector module



**NOTE:** The C0-00DR-D is derated to 2A maximum per Common when used with the ZIPLink wiring system.

## C0-00AR-D – 8 AC Input/6 Relay Output Micro PLC

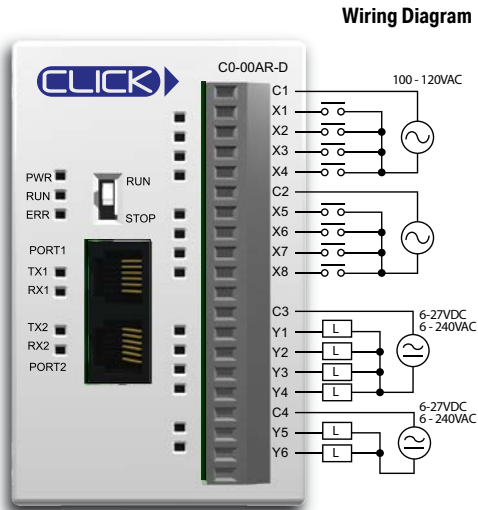

Built-in I/O Specifications - Inputs	
Inputs per Module	8
Operating Voltage Range	100-120 VAC
Input Voltage Range	80-144 VAC
AC Frequency	47-63 Hz
Input Current	8.5 mA @ 100VAC at 50Hz 10mA @ 100VAC at 60Hz
Maximum Input Current	16mA @ 144VAC at 55°C or 131°F
Input Impedance	15kΩ @ 50Hz 12kΩ @ 60Hz
ON Voltage Level	> 60VAC
OFF Voltage Level	< 20VAC
Minimum ON Current	5mA
Maximum OFF Current	2mA
OFF to ON Response	Max 40ms
ON to OFF Response	Max 40ms
Status Indicators	Logic Side (8 points, green LED)
Commons	2 (4 points/common) Isolated

General Specifications	
Current Consumption at 24VDC	120mA
Terminal Block Replacement Part No.	C0-16TB
Weight	5.6 oz (160g)

### Equivalent Input Circuit

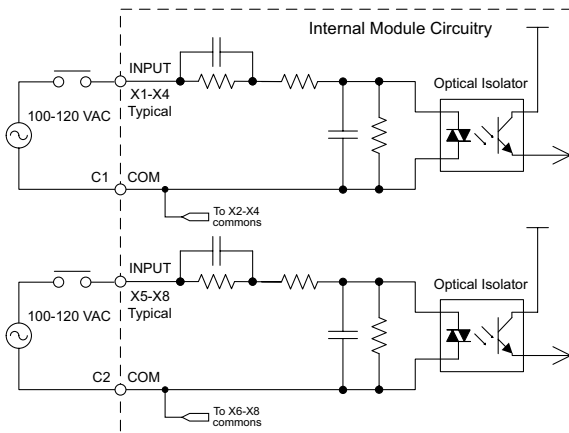

### C0-00AR-D Temperature Derating Chart

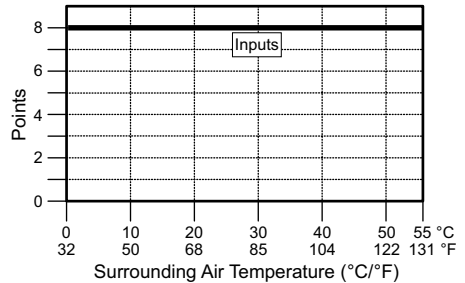

## C0-00AR-D – 8 AC Input/6 Relay Output Micro PLC (continued)

Built-in I/O Specifications - Outputs	
Outputs per Module	6
Operating Voltage Range	6-240 VAC (47-63 Hz), 6-27 VDC
Output Voltage Range	5-264 VAC (47-63 Hz), 5-30 VDC
Output Type	Relay, form A (SPST)
Maximum Current	1A/point; C3: 4A/common, C4: 2A/common
Minimum Load Current	5mA @ 5VDC
Maximum Inrush Current	3A for 10ms
OFF to ON Response	< 15ms
ON to OFF Response	< 15ms
Status Indicators	Logic Side (6 points, red LED)
Commons	2 (4 points/com & 2 points/com) Isolated

C0-00AR-D Temperature Derating Chart

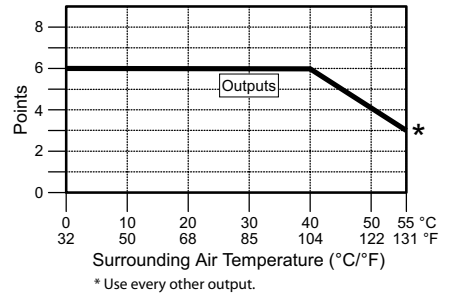

Typical Relay Life (Operations) at Room Temperature	
Voltage & Load Type	Relay Life
30VDC, 1A Resistive	300,000 cycles
30VDC, 1A Solenoid	50,000 cycles
250VAC, 1A Resistive	500,000 cycles
250VAC, 1A Solenoid	200,000 cycles
ON to OFF = 1 cycle	

### Equivalent Output Circuit

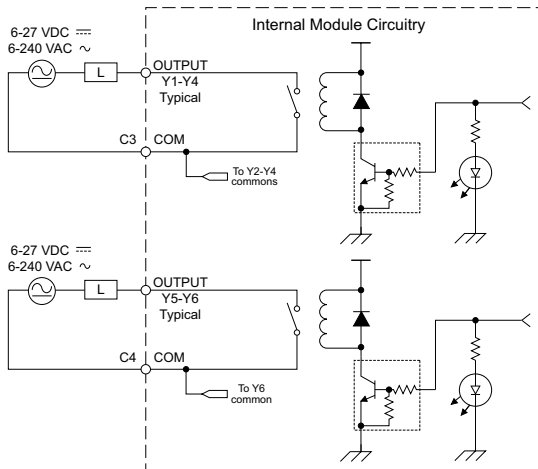

### ZIPLink Pre-Wired PLC Connection Cables and Modules for CLICK PLC

- 20-pin connector cable
- ZL-C0-CBL20 (0.5 m length)
- ZL-C0-CBL20-1 (1.0 m length)
- ZL-C0-CBL20-2 (2.0 m length)



- ZL-RTB20
- 20-pin feed-through connector module



**NOTE:** The C0-00AR-D is derated to 2A maximum per Common when used with the ZIPLink wiring system.

# Standard PLC Unit Specifications

## C0-01DD1-D – 8 DC Input/6 Sinking DC Output Micro PLC

Wiring Diagram

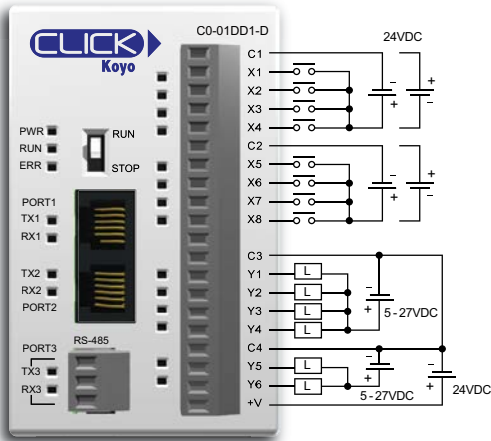

Built-in I/O Specifications - Inputs	
Inputs per Module	8 (Sink/Source)
Operating Voltage Range	24VDC
Input Voltage Range	21.6-26.4 VDC
Input Current	X1-2: Typ 5mA @ 24VDC X3-8: Typ 4mA @ 24VDC
Maximum Input Current	X1-2: 6.0 mA @ 26.4 VDC X3-8: 5.0 mA @ 26.4 VDC
Input Impedance	X1-2: 4.7 kΩ @ 24VDC X3-8: 6.8 kΩ @ 24VDC
ON Voltage Level	X1-2: > 19VDC X3-8: > 19VDC
OFF Voltage Level	X1-2: < 4VDC X3-8: < 7VDC
Minimum ON Current	X1-2: 4.5 mA X3-8: 3.5 mA
Maximum OFF Current	X1-2: 0.1 mA X3-8: 0.5 mA
OFF to ON Response	X1-2: Typ 5μs Max 20μs X3-8: Typ 2ms Max 10ms
ON to OFF Response	X1-2: Typ 5μs Max 20μs X3-8: Typ 3ms Max 10ms
Status Indicators	Logic Side (8 points, green LED)
Commons	2 (4 points/common) Isolated



**NOTE:** When using Standard PLCs, you must use CLICK programming software version V1.20 or later.

General Specifications	
Current Consumption at 24VDC	140mA
Terminal Block Replacement Part No.	C0-16TB
Weight	5.0 oz (140g)

Equivalent Input Circuit

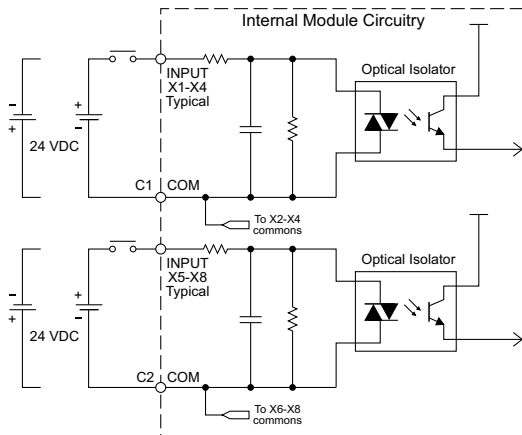

C0-01DD1-D Temperature Derating Chart

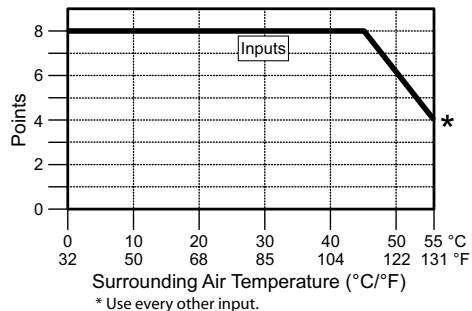

C0-01DD1-D – 8 DC Input/6 Sinking DC Output Micro PLC (continued)

Built-in I/O Specifications - Outputs	
Outputs per Module	6 (Sink)
Operating Voltage Range	5-27 VDC
Output Voltage Range	4-30 VDC
Maximum Output Current	0.1 A/point; C3: 0.4 A/common, C4: 0.2 A/common
Minimum Output Current	0.2 mA
Maximum Leakage Current	0.1 mA @ 30.0 VDC
On Voltage Drop	0.5 VDC @ 0.1 A
Maximum Inrush Current	150mA for 10 ms
OFF to ON Response	Y1: typ 5 $\mu$ s; max 20 $\mu$ s Y2-6: < 0.5 ms
ON to OFF Response	Y1: Typ 5 $\mu$ s; max 20 $\mu$ s Y2-6: < 0.5 ms
Status Indicators	Logic Side (6 points, red LED)
Commons	2 (4 points/com & 2 points/com)
External DC Power Required	20-28 VDC Maximum @ 60mA (All Points On)

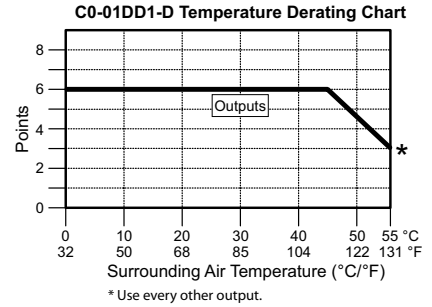

Equivalent Output Circuit

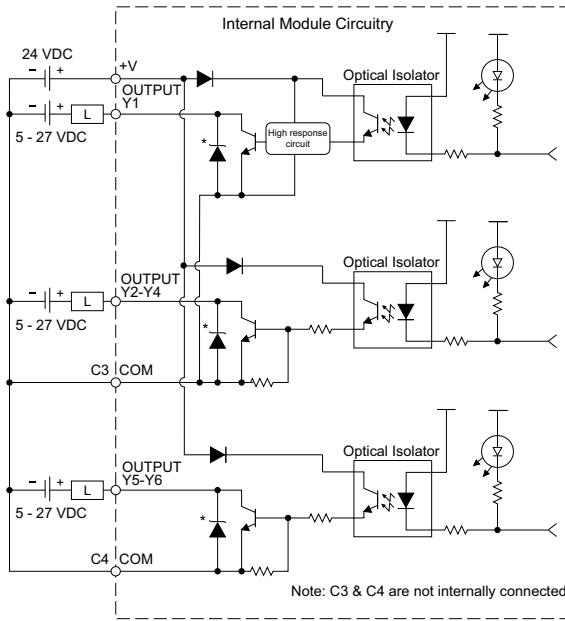

Z/PLink Pre-Wired PLC Connection Cables and Modules for CLICK PLC

- 20-pin connector cable
- ZL-C0-CBL20 (0.5 m length)
- ZL-C0-CBL20-1 (1.0 m length)
- ZL-C0-CBL20-2 (2.0 m length)



- ZL-RTB20
- 20-pin feed-through connector module



## C0-01DD2-D – 8 DC Input/6 Sourcing DC Output Micro PLC

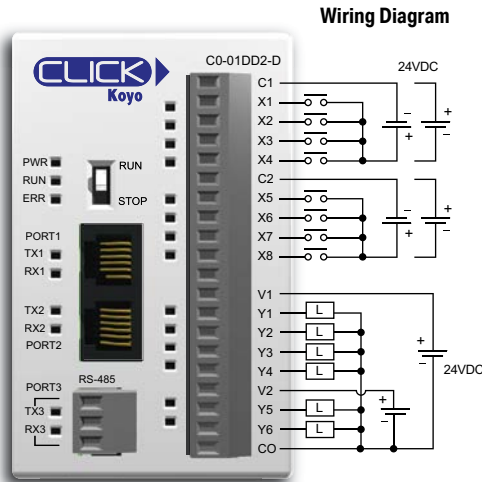

Built-in I/O Specifications - Inputs	
Inputs per Module	8 (Sink/Source)
Operating Voltage Range	24VDC
Input Voltage Range	21.6-26.4 VDC
Input Current	X1-2: Typ 5mA @ 24VDC X3-8: Typ 4mA @ 24VDC
Maximum Input Current	X1-2: 6.0 mA @ 26.4 VDC X3-8: 5.0 mA @ 26.4 VDC
Input Impedance	X1-2: 4.7 kΩ @ 24VDC X3-8: 6.8 kΩ @ 24VDC
ON Voltage Level	X1-2: > 19VDC X3-8: > 19VDC
OFF Voltage Level	X1-2: < 4VDC X3-8: < 7VDC
Minimum ON Current	X1-2: 4.5 mA X3-8: 3.5 mA
Maximum OFF Current	X1-2: 0.1 mA X3-8: 0.5 mA
OFF to ON Response	X1-2: Typ 5μs Max 20μs X3-8: Typ 2ms Max 10ms
ON to OFF Response	X1-2: Typ 5μs Max 20μs X3-8: Typ 3ms Max 10ms
Status Indicators	Logic Side (8 points, green LED)
Commons	2 (4 points/common) Isolated



**NOTE:** When using Standard PLCs, you must use CLICK programming software version V1.20 or later.

General Specifications	
Current Consumption at 24VDC	140mA
Terminal Block Replacement Part No.	C0-16TB
Weight	5.0 oz (140g)

### Equivalent Input Circuit

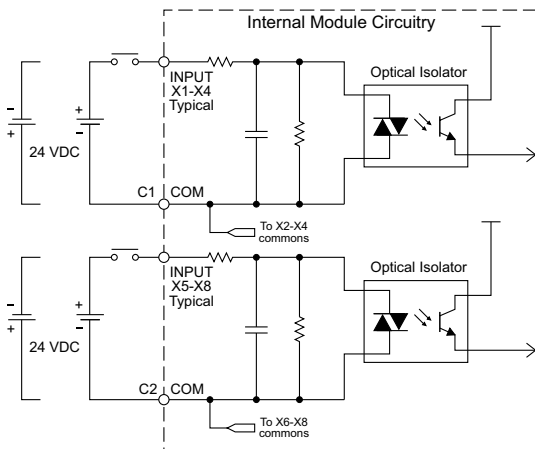

C0-01DD2-D Temperature Derating Chart

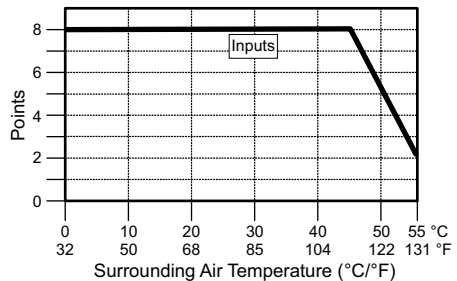

C0-01DD2-D – 8 DC Input/6 Sourcing DC Output Micro PLC (continued)

Built-in I/O Specifications - Outputs	
Outputs per Module	6 (Source)
Operating Voltage Range	24VDC
Output Voltage Range	19.2–30 VDC
Maximum Output Current	0.1 A/point, 0.6 A/common
Minimum Output Current	0.2 mA
Maximum Leakage Current	0.1 mA @ 30VDC
On Voltage Drop	Y1: 1.0 VDC @ 0.1 A Y2-6: 0.5 VDC @ 0.1 A
Maximum Inrush Current	150mA for 10ms
OFF to ON Response	Y1: Typ 5 $\mu$ s; Max 20 $\mu$ s Y2-6: < 0.5 ms
ON to OFF Response	Y1: Typ 5 $\mu$ s; Max 20 $\mu$ s Y2-6: < 0.5 ms
Status Indicators	Logic Side (6 points, red LED)
Commons	1 (6 points/common)

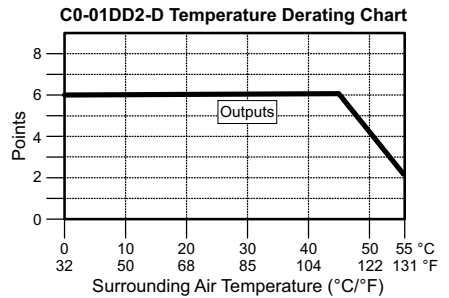

Equivalent Output Circuit

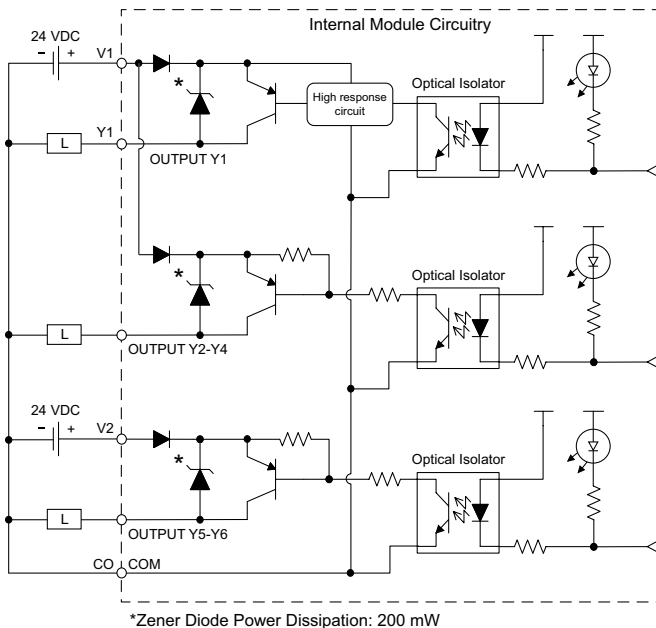

Z/PLink Pre-Wired PLC Connection Cables and Modules for CLICK PLC

- 20-pin connector cable
- ZL-C0-CBL20 (0.5 m length)
- ZL-C0-CBL20-1 (1.0 m length)
- ZL-C0-CBL20-2 (2.0 m length)



- ZL-RTB20
- 20-pin feed-through connector module



## C0-01DR-D – 8 DC Input/6 Relay Output Micro PLC

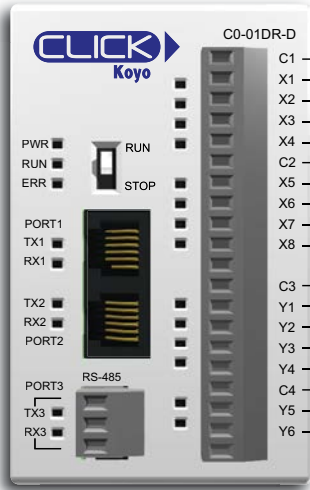

Wiring Diagram

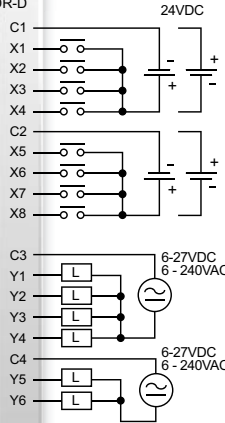

Built-in I/O Specifications - Inputs	
Inputs per Module	8 (Sink/Source)
Operating Voltage Range	24VDC
Input Voltage Range	21.6-26.4 VDC
Input Current	X1-2: Typ 5mA @ 24VDC X3-8: Typ 4mA @ 24VDC
Maximum Input Current	X1-2: 6.0 mA @ 26.4 VDC X3-8: 5.0 mA @ 26.4 VDC
Input Impedance	X1-2: 4.7 kΩ @ 24VDC X3-8: 6.8 kΩ @ 24VDC
ON Voltage Level	X1-2: > 19VDC X3-8: > 19VDC
OFF Voltage Level	X1-2: < 4VDC X3-8: < 7VDC
Minimum ON Current	X1-2: 4.5 mA X3-8: 3.5 mA
Maximum OFF Current	X1-2: 0.1 mA X3-8: 0.5 mA
OFF to ON Response	X1-2: Typ 5μs Max 20μs X3-8: Typ 2ms Max 10ms
ON to OFF Response	X1-2: Typ 5μs Max 20μs X3-8: Typ 3ms Max 10ms
Status Indicators	Logic Side (8 points, green LED)
Commons	2 (4 points/common) Isolated



**NOTE:** When using Standard PLCs, you must use CLICK programming software version V1.20 or later.

General Specifications	
Current Consumption at 24VDC	140mA
Terminal Block Replacement Part No.	C0-16TB
Weight	5.6 oz (160g)

### Equivalent Input Circuit

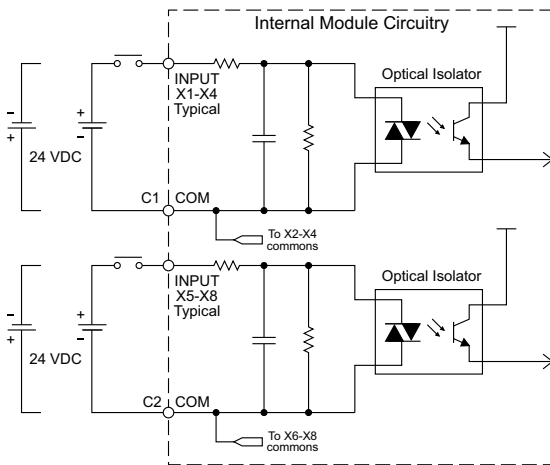

C0-01DR-D Temperature Derating Chart

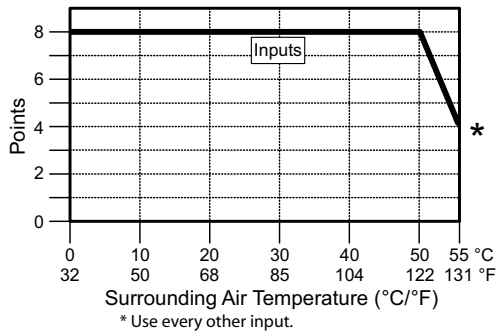

C0-01DR-D – 8 DC Input/6 Relay Output Micro PLC (continued)

Built-in I/O Specifications - Outputs	
Outputs per Module	6
Operating Voltage Range	6-240 VAC (47-63 Hz), 6-27 VDC
Output Voltage Range	5-264 VAC (47-63 Hz), 5-30 VDC
Output Type	Relay, form A (SPST)
Maximum Current	1A/point; C3: 4A/common, C4: 2A/common
Minimum Load Current	5mA @ 5VDC
Maximum Inrush Current	3A for 10ms
OFF to ON Response	< 15ms
ON to OFF Response	< 15ms
Status Indicators	Logic Side (6 points, red LED)
Commons	2 (4 points/com & 2 points/com) Isolated

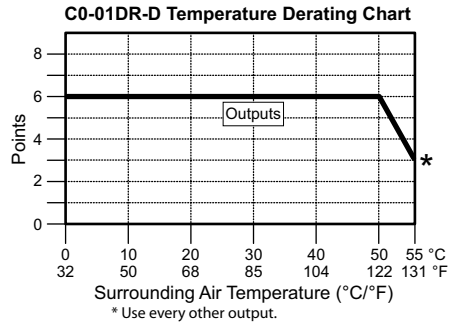

Typical Relay Life (Operations) at Room Temperature	
Voltage & Load Type	Relay Life
30VDC, 1A Resistive	300,000 cycles
30VDC, 1A Solenoid	50,000 cycles
250VAC, 1A Resistive	500,000 cycles
250VAC, 1A Solenoid	200,000 cycles
ON to OFF = 1 cycle	

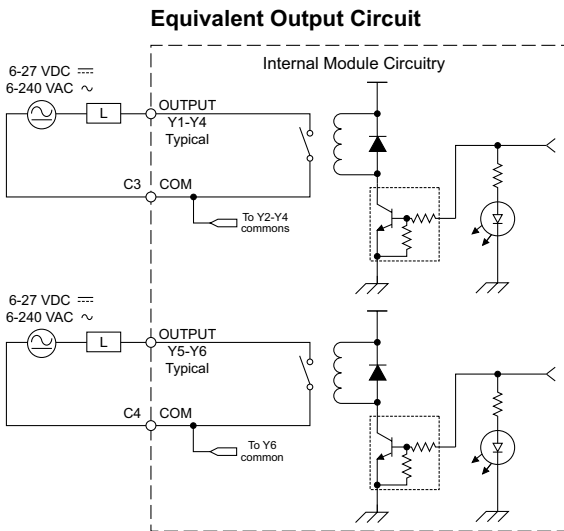

**NOTE:** The C0-01DR-D is derated to 2A maximum per Common when used with the ZIPLink wiring system.

ZIPLink Pre-Wired PLC Connection Cables and Modules for CLICK PLC

- 20-pin connector cable
- ZL-C0-CBL20 (0.5 m length)
- ZL-C0-CBL20-1 (1.0 m length)
- ZL-C0-CBL20-2 (2.0 m length)



- ZL-RTB20
- 20-pin feed-through connector module



## C0-01AR-D – 8 AC Input/6 Relay Output Micro PLC

Wiring Diagram

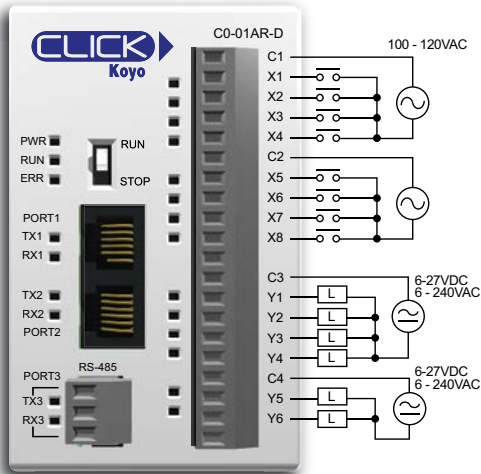

Built-in I/O Specifications - Inputs	
Inputs per Module	8
Operating Voltage Range	100–120 VAC
Input Voltage Range	80–144 VAC
AC Frequency	47–63 Hz
Input Current	8.5 mA @ 100VAC at 50Hz 10 mA @ 100VAC at 60Hz
Maximum Input Current	16 mA @ 144VAC
Input Impedance	15kΩ @ 50Hz 12kΩ @ 60Hz
ON Voltage Level	> 60VAC
OFF Voltage Level	< 20VAC
Minimum ON Current	5mA
Maximum OFF Current	2mA
OFF to ON Response	Max 40ms
ON to OFF Response	Max 40ms
Status Indicators	Logic Side (8 points, green LED)
Commons	2 (4 points/common) Isolated

General Specifications	
Current Consumption at 24VDC	140mA
Terminal Block Replacement Part No.	C0-16TB
Weight	5.6 oz (160g)



**NOTE:** When using Standard PLCs, you must use **CLICK** programming software version V1.20 or later.

Equivalent Input Circuit

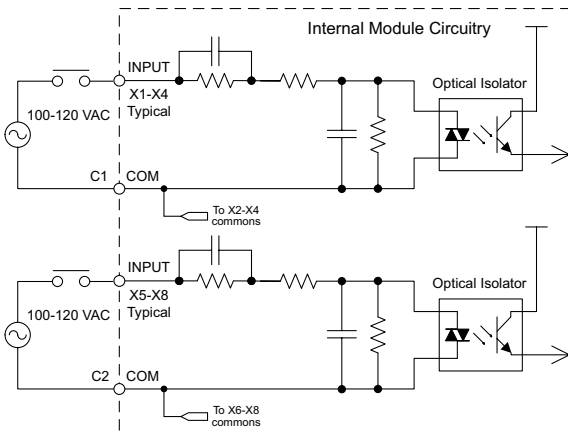

C0-01AR-D Temperature Derating Chart

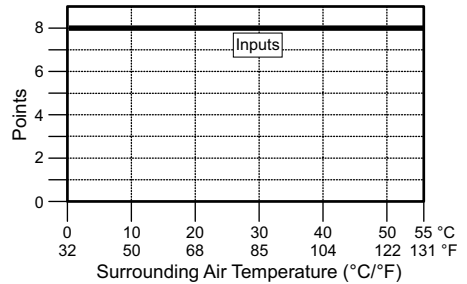

C0-01AR-D – 8 AC Input/6 Relay Output Micro PLC (continued)

Built-in I/O Specifications - Outputs	
Outputs per Module	6
Operating Voltage Range	6–240 VAC (47–63 Hz), 6–27 VDC
Output Voltage Range	5–264 VAC (47–63 Hz), 5–30 VDC
Output Type	Relay, form A (SPST)
Maximum Current	1 A/point; C3: 4A/common, C4: 2A/common
Minimum Load Current	5mA @ 5VDC
Maximum Inrush Current	3A for 10ms
OFF to ON Response	< 15ms
ON to OFF Response	< 15ms
Status Indicators	Logic Side (6 points, red LED)
Commons	2 (4 points/com & 2 points/com) Isolated

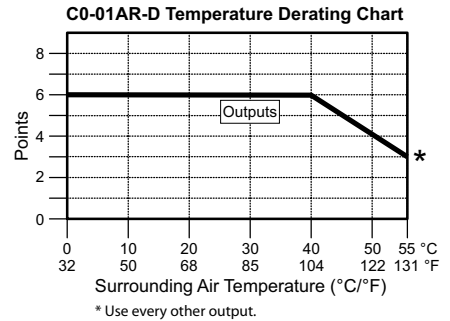

Typical Relay Life (Operations) at Room Temperature	
Voltage & Load Type	Relay Life
30VDC, 1A Resistive	300,000 cycles
30VDC, 1A Solenoid	50,000 cycles
250VAC, 1A Resistive	500,000 cycles
250VAC, 1A Solenoid	200,000 cycles
ON to OFF = 1 cycle	

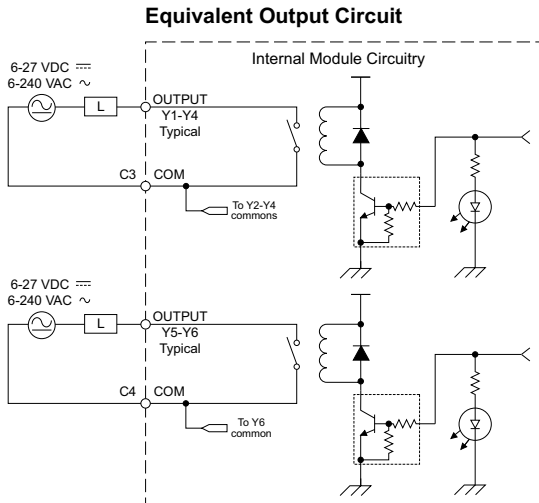

ZIPLink Pre-Wired PLC Connection Cables and Modules for CLICK PLC

- 20-pin connector cable
- ZL-C0-CBL20 (0.5 m length)
- ZL-C0-CBL20-1 (1.0 m length)
- ZL-C0-CBL20-2 (2.0 m length)



**NOTE:** The C0-01AR-D is derated to 2A maximum per Common when used with the ZIPLink wiring system.

ZL-RTB20  
20-pin feed-through connector module



# Analog PLC Unit Specifications

C0-02DD1-D – 4 DC Input/4 Sinking DC Output; 2 Analog In/2 Analog Out Micro PLC

Wiring Diagram

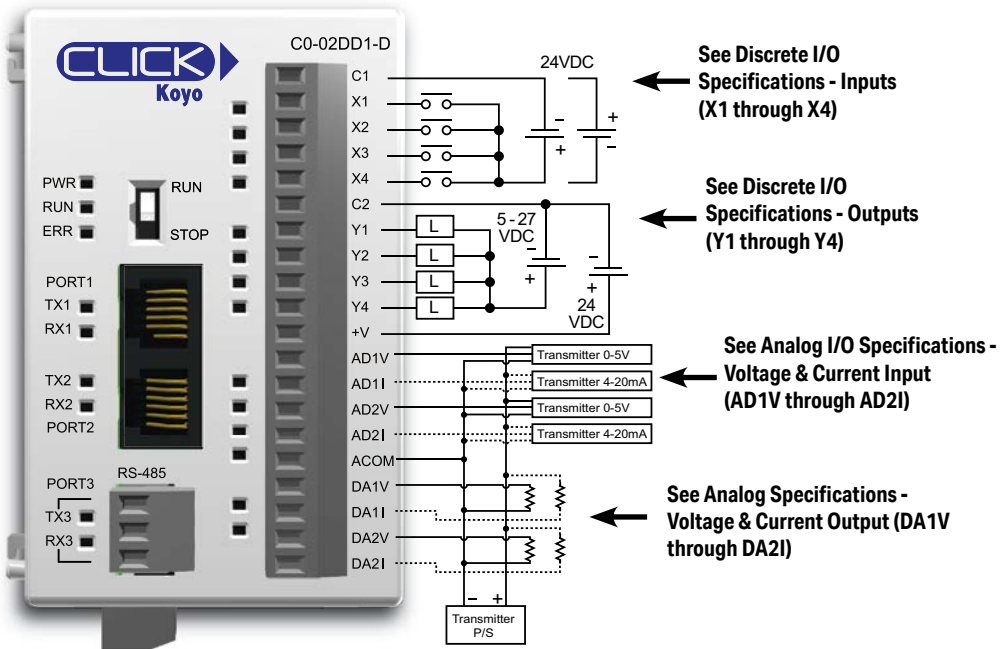

General Specifications	
Current Consumption at 24VDC	140mA
Terminal Block Replacement Part No.	C0-16TB
Weight	5.3 oz (150g)

**NOTE:** Please refer to the Analog I/O Configuration section in Chapter 3 for information on using the analog I/O.



**NOTE:** There are no ZIPLink pre-wired PLC connection cables and modules for the Analog PLCs (cannot mix discrete I/O and analog I/O signals in a ZIPLink cable).



**WARNING:** You must use proper software and firmware for this PLC unit.

Serial Number	Software	Firmware
Before 171208001	V1.12 or later	V1.10 or later
171208001-25Z319999	V2.10 or later	V2.10 or later
260100001 or later	V2.60 to V2.99 OR V3.70 or Later (Cannot be used with V3.00 thru V3.60)	V2.61 to V2.99 OR V3.70 or Later (Cannot be used with V3.00 thru V3.60)

You can find the serial number on the bottom of the product label.

C0-02DD1-D (continued)

X1 - X4

Discrete I/O Specifications - Inputs	
Inputs per Module	4 (Sink/Source)
Operating Voltage Range	24VDC
Input Voltage Range	21.6–26.4 VDC
Input Current	X1-2: Typ 5mA @ 24VDC X3-4: Typ 4mA @ 24VDC
Maximum Input Current	X1-2: 6.0 mA @ 26.4 VDC X3-4: 5.0 mA @ 26.4 VDC
Input Impedance	X1-2: 4.7 kΩ @ 24VDC X3-4: 6.8 kΩ @ 24VDC
ON Voltage Level	X1-2: > 19VDC X3-4: > 7VDC
OFF Voltage Level	X1-2: < 4VDC X3-4: < 7VDC
Minimum ON Current	X1-2: 4.5 mA X3-4: 3.5 mA
Maximum OFF Current	X1-2: 0.1 mA X3-4: 0.5 mA
OFF to ON Response	X1-2: Typ 5μs Max 20μs* X3-4: Typ 2ms Max 10ms
ON to OFF Response	X1-2: Typ 5μs Max 20μs* X3-4: Typ 3ms Max 10ms
Status Indicators	Logic Side (4 points, green LED)
Commons	1 (4 points/common)

\* Threshold level is 70% amplitude.

Equivalent Discrete Input Circuit

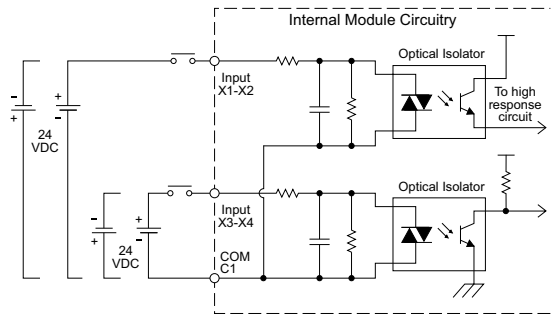

C0-02DD1-D Temperature Derating Chart

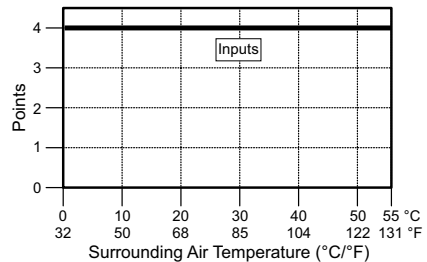

Y1 - Y4

Discrete I/O Specifications - Outputs	
Outputs per Module	4 (Sink)
Operating Voltage Range	5–27 VDC
Output Voltage Range	4–30 VDC
Maximum Output Current	0.1 A/point; 0.4 A/common
Minimum Output Current	0.2 mA
Maximum Leakage Current	0.1 mA @ 30.0 VDC
On Voltage Drop	0.5 VDC @ 0.1 A
Maximum Inrush Current	150 mA for 10ms
OFF to ON Response	Y1: Typ 5μs; Max 20μs Y2-4: < 0.5 ms
ON to OFF Response	Y1: Typ 5μs; Max 20μs Y2-4: < 0.5 ms
Status Indicators	Logic Side (4 points, red LED)
Commons	1 (4 points/common)
External DC Power Required	20–28 VDC Maximum @ 60mA (all points on)

Equivalent Discrete Output Circuit

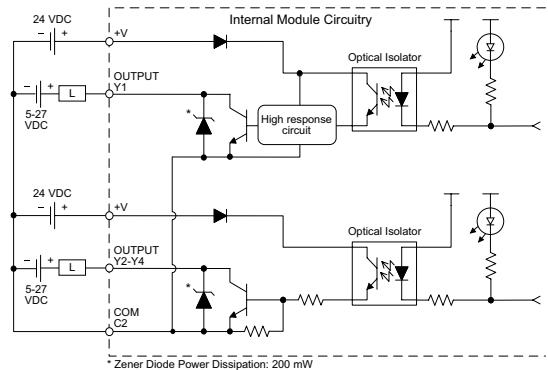

C0-02DD1-D Temperature Derating Chart

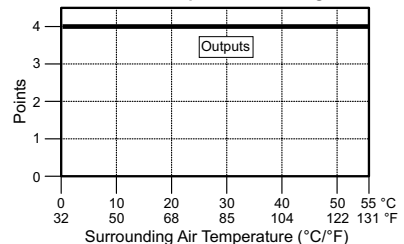

## C0-02DD1-D (continued)

### AD1V - AD2I

Analog Specifications - Voltage Input	
Number of Channels	2 (voltage/current selectable)
Input Range	0-5 VDC (6VDC Max.)
Resolution	12-bit
Conversion Time	50ms
Input Impedance	25kΩ 150kΩ (Serial numbers prior to 171208001)
Input Stability	±2 LSB maximum
Full-Scale Calibration Error	±1.2% maximum
Offset Calibration Error	±5mV maximum
Accuracy vs. Temperature Error	±100ppm / °C maximum

Analog Voltage Input Circuit

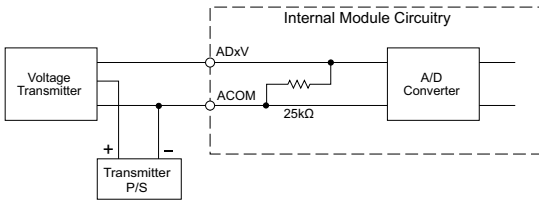

Analog Specifications - Current Input	
Inputs per Module	2 (voltage/current selectable)
Input Range	4-20 mA (sink)
Resolution	12-bit
Conversion Time	50ms
Input Impedance	100Ω 200Ω (Serial numbers prior to 171208001)
Input Stability	±2 LSB
Full-Scale Calibration Error	±1% maximum
Offset Calibration Error	±0.1 mA maximum
Accuracy vs. Temperature Error	±100ppm / °C maximum

Analog Current Input Circuit

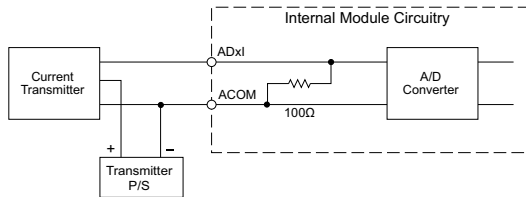

### DA1V - DA2I

Analog Specifications - Voltage Output	
Outputs per Module	2 (voltage/current selectable)
Output Range	0-5 VDC
Resolution	12-bit
Conversion Time	1ms
Load Impedance	2kΩ minimum (output current 2.5 mA maximum)
Full-Scale Calibration Error	±0.8% maximum
Offset Calibration Error	±5mV maximum
Accuracy vs. Temperature Error	±100ppm / °C maximum

Analog Voltage Output Circuit

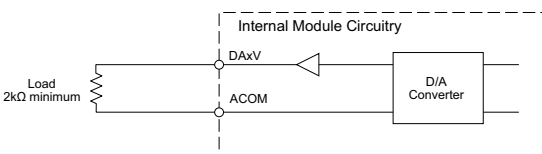

Analog Specifications - Current Output	
Outputs per Module	2 (voltage/current selectable)
Output Range	4-20 mA (sink)
Resolution	12-bit
Conversion Time	1ms
Loop Supply Voltage	DC 18-30 V
Load Impedance	250Ω Load Power Supply: DC 18V: 600Ω maximum DC 24V: 900Ω maximum DC 30V: 1200Ω maximum
Full-Scale Calibration Error	±1% maximum
Offset Calibration Error	±0.1 mA maximum
Accuracy vs. Temperature Error	±100ppm / °C maximum

Analog Current Output Circuit

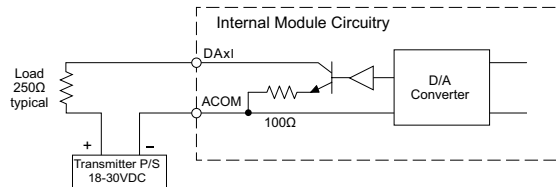

## C0-02DD2-D – 4 DC Input/4 Sourcing DC Output; 2 Analog In/2 Analog Out Micro PLC

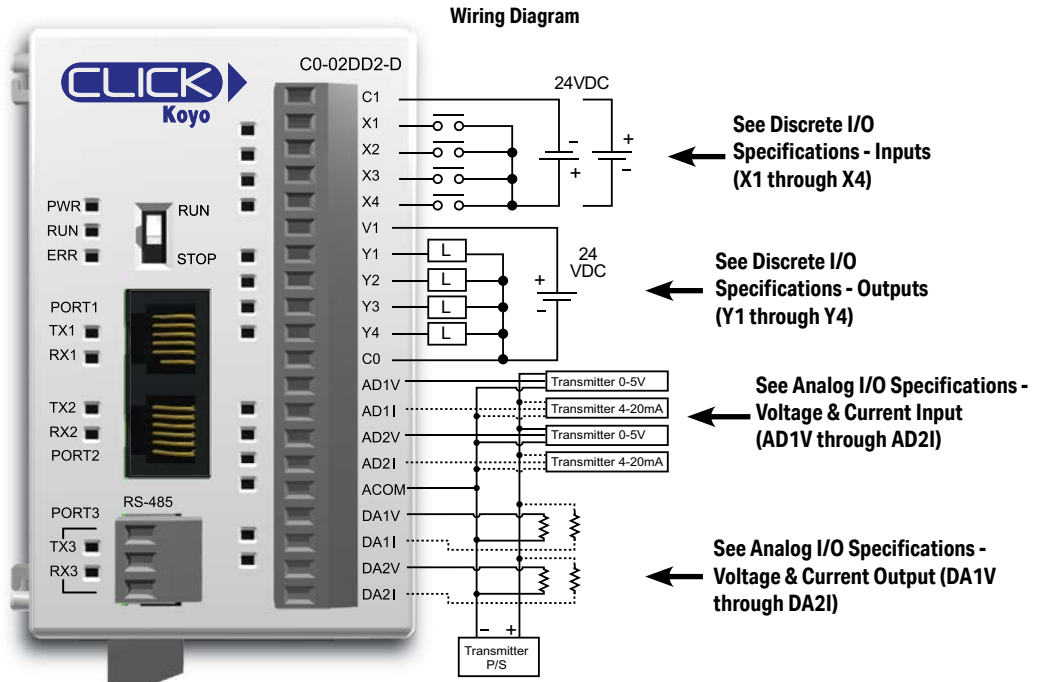

General Specifications	
<b>Current Consumption at 24VDC</b>	140mA
<b>Terminal Block Replacement Part No.</b>	C0-16TB
<b>Weight</b>	5.3 oz (150g)



**WARNING:** You must use proper software and firmware for this PLC unit.

Serial Number	Software	Firmware
Before 174018001	V1.12 or later	V1.10 or later
174018001-25Z319999	V2.10 or later	V2.10 or later
260100001 or later	V2.60 to V2.99 OR V3.70 or Later (Cannot be used with V3.00 thru V3.60)	V2.61 to V2.99 OR V3.70 or Later (Cannot be used with V3.00 thru V3.60)

You can find the serial number on the bottom of the product label.



**NOTE:** Please refer to the Analog I/O Configuration section in Chapter 3 for information on using the analog I/O.

**NOTE:** There are no ZIPLink pre-wired PLC connection cables and modules for the Analog PLCs (cannot mix discrete I/O and analog I/O signals in a ZIPLink cable).

## C0-02DD2-D (continued)

X1 - X4

Discrete I/O Specifications - Inputs	
Inputs per Module	4 (Sink/Source)
Operating Voltage Range	24VDC
Input Voltage Range	21.6–26.4 VDC
Input Current	X1-2: Typ 5mA @ 24VDC X3-4: Typ 4mA @ 24VDC
Maximum Input Current	X1-2: 6.0 mA @ 26.4 VDC X3-4: 5.0 mA @ 26.4 VDC
Input Impedance	X1-2: 4.7 kΩ @ 24VDC X3-4: 6.8 kΩ @ 24VDC
ON Voltage Level	X1-2: > 19VDC X3-4: > 19VDC
OFF Voltage Level	X1-2: < 4VDC X3-4: < 7VDC
Minimum ON Current	X1-2: 4.5 mA X3-4: 3.5 mA
Maximum OFF Current	X1-2: 0.1 mA X3-4: 0.5 mA
OFF to ON Response	X1-2: Typ 5μs Max 20μs* X3-4: Typ 2ms Max 10ms
ON to OFF Response	X1-2: Typ 5μs Max 20μs* X3-4: Typ 3ms Max 10ms
Status Indicators	Logic Side (4 points, green LED)
Commons	1 (4 points/common)

\* Threshold level is 70% amplitude.

Y1 - Y4

Discrete I/O Specifications - Outputs	
Outputs per Module	4 (Source)
Operating Voltage Range	24VDC
Output Voltage Range	19.2–30 VDC
Maximum Output Current	0.1 A/point, 0.4 A/common
Minimum Output Current	0.2 mA
Maximum Leakage Current	0.1mA @ 30VDC
On Voltage Drop	Y1: 1 VDC @ 0.1A Y2-4: 0.5VDC @ 0.1mA
Maximum Inrush Current	150mA for 10ms
OFF to ON Response	Y1: Typ 5μs; Max 20μs Y2-4: < 0.5 ms
ON to OFF Response	Y1: Typ 5μs; Max 20μs Y2-4: < 0.5 ms
Status Indicators	Logic Side (4 points, red LED)
Commons	1 (4 points/common)

Equivalent Discrete Input Circuit

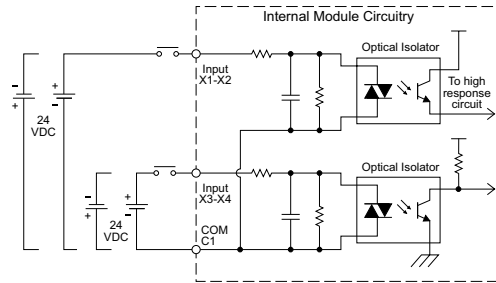

C0-02DD2-D Temperature Derating Chart

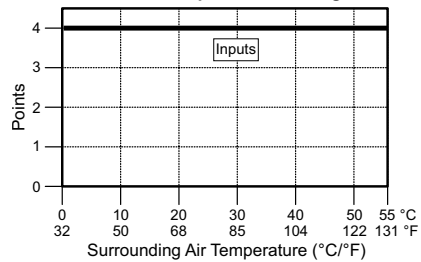

Equivalent Output Circuit

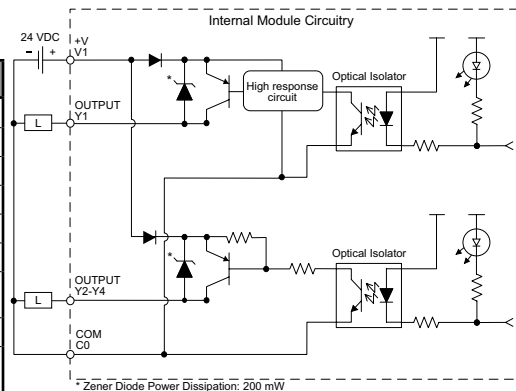

C0-02DD2-D Temperature Derating Chart

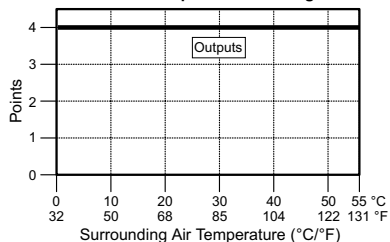

C0-02DD2-D (continued)

AD1V - AD2I

Analog Specifications - Voltage Input	
Number of Channels	2 (voltage/current selectable)
Input Range	0-5 VDC (6 VDC Max.)
Resolution	12-bit
Conversion Time	50ms
Input Impedance	25kΩ 150kΩ (Serial numbers prior to 174018001)
Input Stability	±2 LSB maximum
Full-Scale Calibration Error	±1.2% maximum
Offset Calibration Error	±5mV maximum
Accuracy vs. Temperature Error	±100ppm / °C maximum

Analog Specifications - Current Input	
Inputs per Module	2 (voltage/current selectable)
Input Range	4-20 mA (sink)
Resolution	12-bit
Conversion Time	50ms
Input Impedance	100Ω 200Ω (Serial numbers prior to 174018001)
Input Stability	±2 LSB
Full-Scale Calibration Error	±1% maximum
Offset Calibration Error	±0.1 mA maximum
Accuracy vs. Temperature Error	±100ppm / °C maximum

Analog Voltage Input Circuit

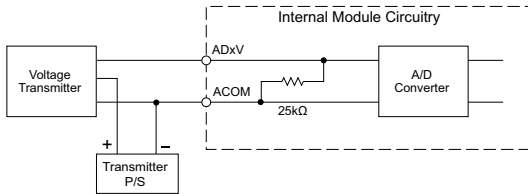

Analog Current Input Circuit

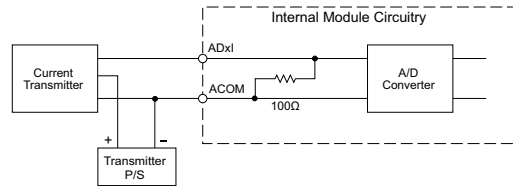

DA1V - DA2I

Analog Specifications - Voltage Output	
Outputs per Module	2 (voltage/current selectable)
Output Range	0-5 VDC
Resolution	12-bit
Conversion Time	1ms
Load Impedance	2kΩ minimum (output current 2.5 mA maximum)
Full-Scale Calibration Error	±0.8% maximum
Offset Calibration Error	±5mV maximum
Accuracy vs. Temperature Error	±100ppm / °C maximum

Analog Specifications - Current Output	
Outputs per Module	2 (voltage/current selectable)
Output Range	4-20 mA (sink)
Resolution	12-bit
Conversion Time	1ms
Loop Supply Voltage	DC 18-30 V
Load Impedance	250Ω Load Power Supply: DC 18V: 600Ω maximum DC 24V: 900Ω maximum DC 30V: 1200Ω maximum
Full-Scale Calibration Error	±1% maximum
Offset Calibration Error	±0.1 mA maximum
Accuracy vs. Temperature Error	±100ppm / °C maximum

Analog Voltage Output Circuit

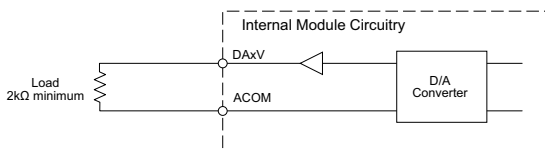

Analog Current Output Circuit

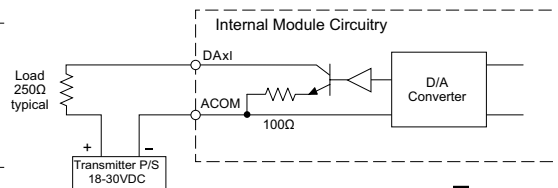

# C0-02DR-D – 4 DC Input/4 Relay Output; 2 Analog In/2 Analog Out Micro PLC

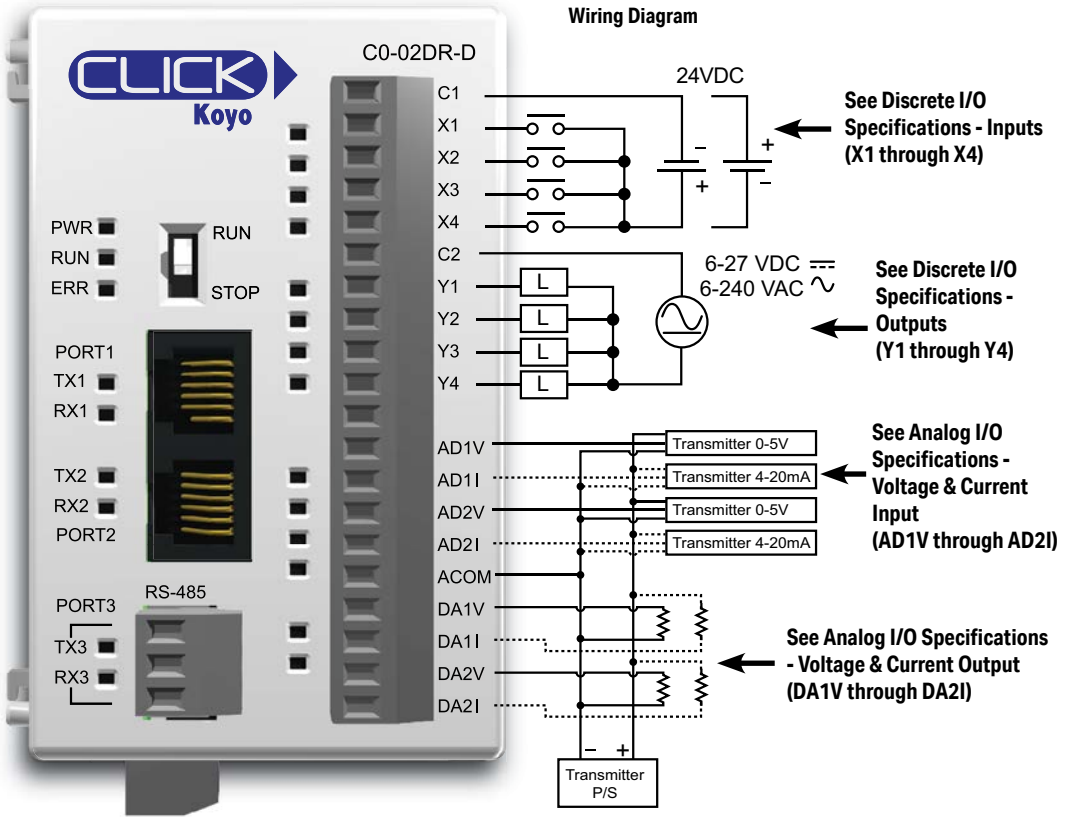

General Specifications	
Current Consumption at 24VDC	140mA
Terminal Block Replacement Part No.	C0-16TB
Weight	5.6 oz (160g)

Typical Relay Life (Operations) at Room Temperature	
Voltage & Load Type	Relay Life
30VDC, 1A Resistive	300,000 cycles
30VDC, 1A Solenoid	50,000 cycles
120VAC, 1A Resistive	500,000 cycles
120VAC, 1A Solenoid	200,000 cycles
ON to OFF = 1 cycle	

**NOTE:** Please refer to "Analog I/O Configuration" in Chapter 3 for information on using the analog I/O.

**NOTE:** There are no ZIPLink pre-wired PLC connection cables and modules for the Analog PLCs (cannot mix discrete I/O and analog I/O signals in a ZIPLink cable).



**WARNING:** You must use proper software and firmware for this PLC unit.

Serial Number	Software	Firmware
Before 173158001	V1.12 or later	V1.10 or later
173158001-25Z319999	V2.10 or later	V2.10 or later
260100001 or later	V2.60 to V2.99 OR V3.70 or Later (Cannot be used with V3.00-V3.60)	V2.61 to V2.99 OR V3.70 or Later (Cannot be used with V3.00-V3.60)
You can find the serial number on the bottom of the product label.		

C0-02DR-D (continued)

X1 - X4

Discrete I/O Specifications - Inputs	
Inputs per Module	4 (Source/Sink)
Operating Voltage Range	24VDC
Input Voltage Range	21.6-26.4 VDC
Input Current	X1-2: Typ 5mA @ 24VDC X3-4: Typ 4mA @ 24VDC
Input Impedance	X1-2: 4.7 kΩ @ 24VDC X3-4: 6.8 kΩ @ 24VDC
ON Voltage Level	X1-2: > 19VDC X3-4: > 19VDC
OFF Voltage Level	X1-2: < 4VDC X3-4: < 7VDC
Minimum ON Current	X1-2: 4.5 mA X3-4: 3.5 mA
Maximum OFF Current	X1-2: 0.1 mA X3-4: 0.5 mA
OFF to ON Response	X1-2: Typ 5μs Max 20μs* X3-4: Typ 2ms Max 10ms
ON to OFF Response	X1-2: Typ 5μs Max 20μs* X3-4: Typ 3ms Max 10ms
Status Indicators	Logic Side (4 points, green LED)
Commons	1 (4 points/common)

\* Threshold level is 70% amplitude.

Equivalent Discrete Input Circuit

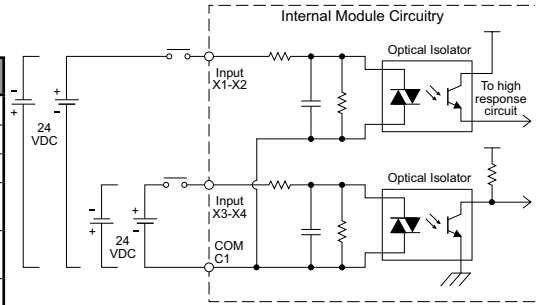

C0-02DR-D Temperature Derating Chart

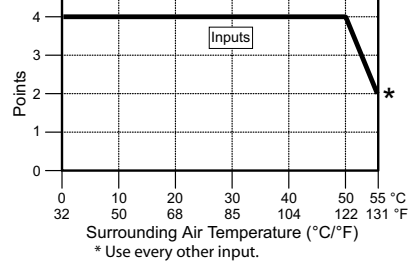

Equivalent Output Circuit

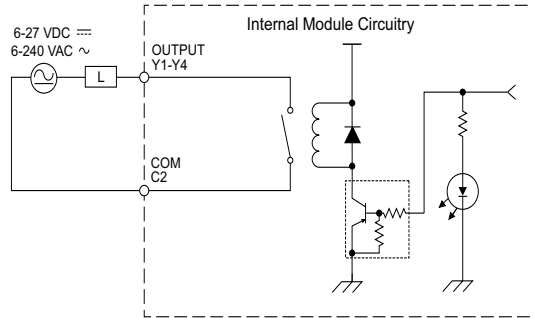

This circuit does not contain built-in protection. Install protection elements such as a fuse outside the module if necessary.

C0-02DR-D Temperature Derating Chart

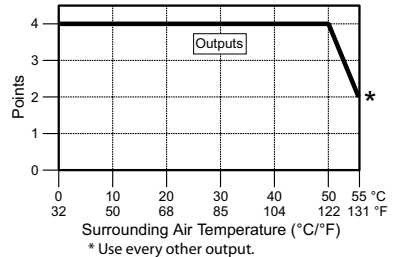

Y1 - Y4

Discrete I/O Specifications - Outputs	
Outputs per Module	4
Operating Voltage Range	6-27 VDC (-15%/+10%)/ 6-240 VAC (-10%/+10%)
Output Type	Relay, form A (SPST)
AC Frequency	47-63 Hz
Maximum Current	1A/point (resistive)
Minimum Load Current	5mA @ 5VDC
Maximum Inrush Current	3A for 10ms
OFF to ON Response	< 15ms
ON to OFF Response	< 15ms
Status Indicators	Logic Side (4 points, red LED)
Commons per Module	1 (4 points/common)
Fuse	None

## C0-02DR-D (continued)

### AD1V – AD2I

Analog Specifications - Voltage Input	
Number of Channels	2 (voltage/current selectable)
Input Range	0–5 VDC (6VDC Max.)
Resolution	12-bit
Conversion Time	50ms
Input Impedance	25kΩ
Input Stability	150Ω (Serial numbers prior to 173158001)
Full-Scale Calibration Error	±2 LSB maximum
Offset Calibration Error	±1.2% maximum
Accuracy vs. Temperature Error	±5mV maximum
Accuracy vs. Temperature Error	±100ppm / °C maximum

Analog Specifications - Current Input	
Inputs per Module	2 (voltage/current selectable)
Input Range	4–20 mA (sink)
Resolution	12-bit
Conversion Time	50ms
Input Impedance	100Ω
Input Stability	200Ω (Serial numbers prior to 173158001)
Full-Scale Calibration Error	±2 LSB
Offset Calibration Error	±1% maximum
Accuracy vs. Temperature Error	±0.1 mA maximum
Accuracy vs. Temperature Error	±100ppm / °C maximum

Analog Voltage Input Circuit

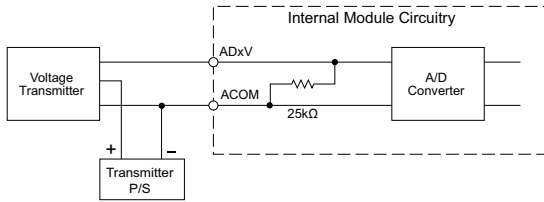

Analog Current Input Circuit

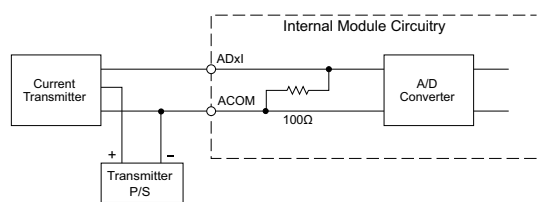

### DA1V – DA2I

Analog Specifications - Voltage Output	
Outputs per Module	2 (voltage/current selectable)
Output Range	0–5 VDC
Resolution	12-bit
Conversion Time	1ms
Load Impedance	2kΩ minimum (output current 2.5 mA maximum)
Full-Scale Calibration Error	±0.8% maximum
Offset Calibration Error	±5mV maximum
Accuracy vs. Temperature Error	±100ppm / °C maximum

Analog Specifications - Current Output	
Outputs per Module	2 (voltage/current selectable)
Output Range	4–20 mA (sink)
Resolution	12-bit
Conversion Time	1ms
Loop Supply Voltage	DC 18–30 V
Load Impedance	250Ω Load Power Supply: DC 18V: 600Ω maximum DC 24V: 900Ω maximum DC 30V: 1200Ω maximum
Full-Scale Calibration Error	±1% maximum
Offset Calibration Error	±0.1 mA maximum
Accuracy vs. Temperature Error	±100ppm / °C maximum

Analog Voltage Output Circuit

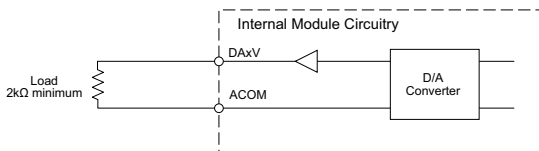

Analog Current Output Circuit

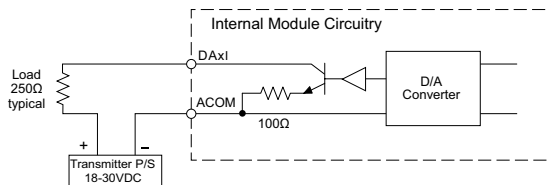

# Ethernet Basic PLC Unit Specifications

## C0-10DD1E-D – 8 DC Input/6 Sinking DC Output Micro PLC

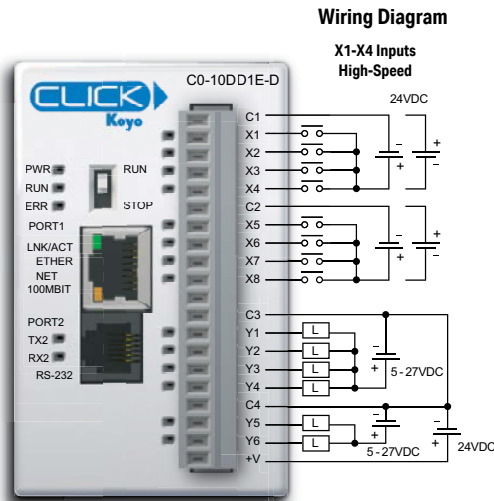

**NOTE:** When using Ethernet Basic PLCs, you must use CLICK programming software version V2.00 or later.

Built-in I/O Specifications - Inputs	
Inputs per Module	8 (Sink/Source)
Operating Voltage Range	24VDC
Input Voltage Range	21.6–26.4 VDC
Input Current	X1-4: Typ 6.5 mA @ 24VDC X5-8: Typ 4mA @ 24VDC
Maximum Input Current	X1-4: 7.0 mA @ 26.4 VDC X5-8: 5.0 mA @ 26.4 VDC
Input Impedance	X1-4: 3.9 kΩ @ 24VDC X5-8: 6.8 kΩ @ 24VDC
Input Frequency (Max)	X1-X4: 100kHz
ON Voltage Level	> 19VDC
OFF Voltage Level	X1-4: < 2VDC X5-8: < 7VDC
Minimum ON Current	X1-4: 4.5 mA X5-8: 3.5 mA
Maximum OFF Current	X1-4: 0.5 mA X5-8: 1.5 mA
OFF to ON Response	X1-4: Typ 3μs Max 5μs X5-8: Typ 2ms Max 10ms
ON to OFF Response	X1-4: Typ 1μs Max 20μs X5-8: Typ 3ms Max 10ms
Status Indicators	Logic Side (8 points, green LED)
Commons	2 (4 points/common) Isolated

General Specifications	
Current Consumption at 24VDC	120mA
Terminal Block Replacement Part No.	C0-16TB
Weight	5.0 oz (140g)

### Equivalent Input Circuit

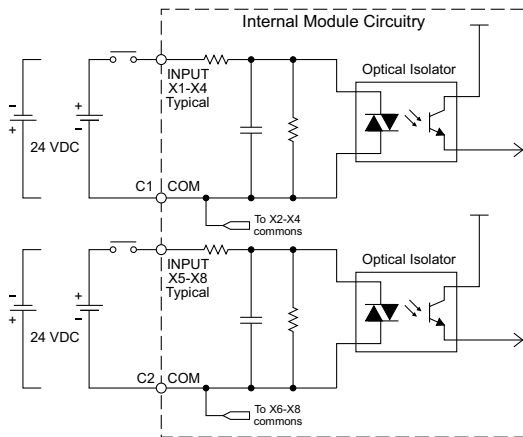

C0-10DD1E-D Temperature Derating Chart

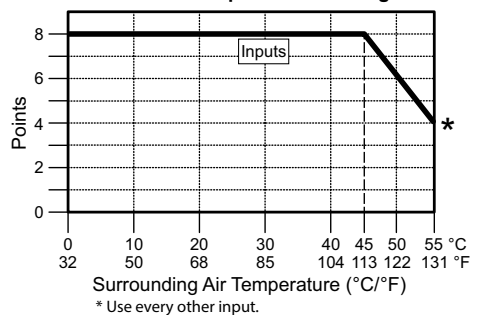

C0-10DD1E-D – 8 DC Input/6 Sinking DC Output Micro PLC (continued)

Built-in I/O Specifications - Outputs	
Outputs per Module	6 (Sink)
Operating Voltage Range	5–27 VDC
Output Voltage Range	4–30 VDC
Maximum Output Current	0.1 A/point; C3: 0.4 A/common, C4: 0.2 A/common
Minimum Output Current	0.2 mA
Maximum Leakage Current	0.5 mA @ 30.0 VDC
On Voltage Drop	0.5 VDC @ 0.1 A
Maximum Inrush Current	150mA for 10ms
OFF to ON Response	Max. 0.5 ms
ON to OFF Response	Max. 0.5 ms
Status Indicators	Logic Side (6 points, red LED)
Commons	2 (4 points/com & 2 points/com)
External DC Power Required	20–28 VDC Maximum @ 60mA (All Points On)

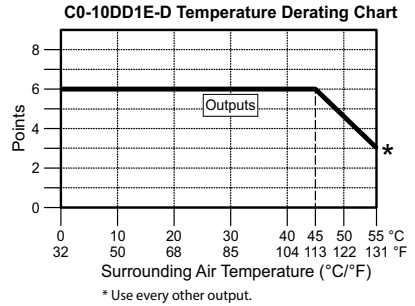

Equivalent Output Circuit

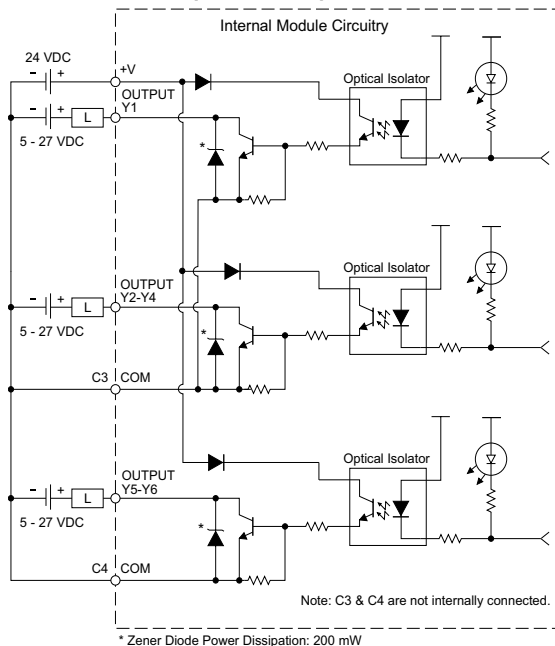

Z/PLink Pre-Wired PLC Connection Cables and Modules for CLICK PLC

- 20-pin connector cable
- ZL-C0-CBL20 (0.5 m length)
- ZL-C0-CBL20-1 (1.0 m length)
- ZL-C0-CBL20-2 (2.0 m length)



- ZL-RTB20
- 20-pin feed-through connector module



# C0-10DD2E-D – 8 DC Input/6 Sourcing DC Output Micro PLC

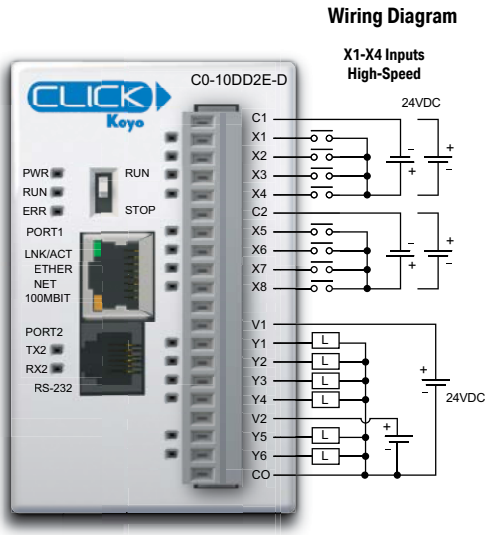

Built-in I/O Specifications - Inputs	
Inputs per Module	8 (Sink/Source)
Operating Voltage Range	24VDC
Input Voltage Range	21.6-26.4 VDC
Input Current	X1-4: Typ 6.5 mA @ 24VDC X5-8: Typ 4mA @ 24VDC
Maximum Input Current	X1-4: 7.0 mA @ 26.4 VDC X5-8: 5.0 mA @ 26.4 VDC
Input Impedance	X1-4: 3.9 kΩ @ 24VDC X5-8: 6.8 kΩ @ 24VDC
Input Frequency (Max)	X1-X4: 100kHz
ON Voltage Level	> 19VDC
OFF Voltage Level	X1-4: < 2VDC X5-8: < 7VDC
Minimum ON Current	X1-4: 4.5 mA X5-8: 3.5 mA
Maximum OFF Current	X1-4: 0.5 mA X5-8: 1.5 mA
OFF to ON Response	X1-4: Typ 3μs Max 5μs X5-8: Typ 2ms Max 10ms
ON to OFF Response	X1-4: Typ 1μs Max 3μs X5-8: Typ 3ms Max 10ms
Status Indicators	Logic Side (8 points, green LED)
Commons	2 (4 points/common) Isolated



**NOTE:** When using Ethernet Basic PLCs, you must use CLICK programming software version V2.00 or later.

General Specifications	
Current Consumption at 24VDC	120mA
Terminal Block Replacement Part No.	C0-16TB
Weight	5.0 oz (140g)

## Equivalent Input Circuit

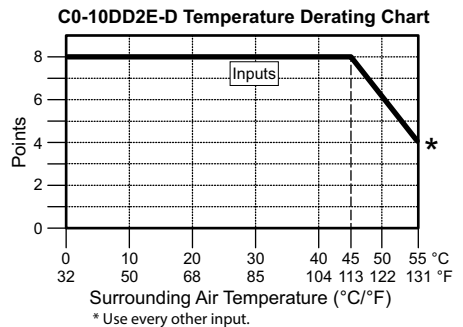
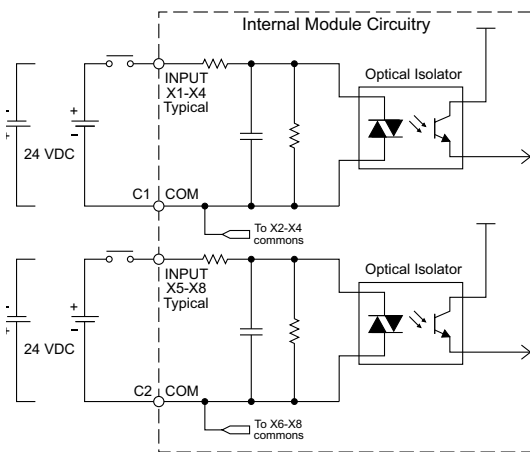

C0-10DD2E-D – 8 DC Input/6 Sourcing DC Output Micro PLC (continued)

Built-in I/O Specifications - Outputs	
Outputs per Module	6 (Source)
Operating Voltage Range	24VDC
Output Voltage Range	19.2-30 VDC
Maximum Output Current	0.1 A/point, 0.6 A/common
Minimum Output Current	0.2 mA
Maximum Leakage Current	0.1 mA @ 30VDC
On Voltage Drop	0.5 VDC @ 0.1 A
Maximum Inrush Current	150mA for 10ms
OFF to ON Response	Max. 0.5 ms
ON to OFF Response	Max 0.5 ms
Status Indicators	Logic Side (6 points, red LED)
Commons	1 (6 points/common)

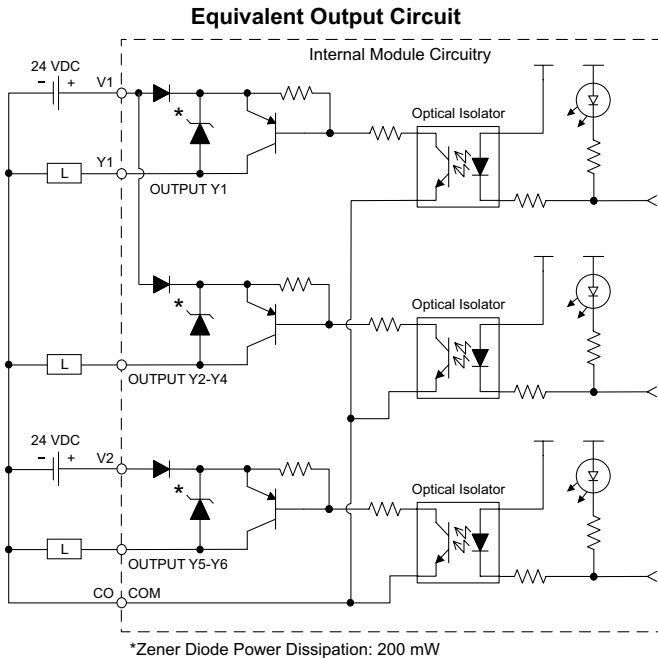
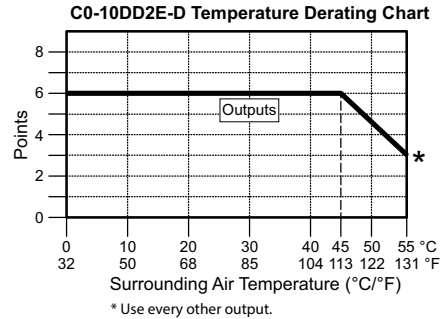

Z/PLink Pre-Wired PLC Connection Cables and Modules for CLICK PLC

- 20-pin connector cable
- ZL-C0-CBL20 (0.5 m length)
- ZL-C0-CBL20-1 (1.0 m length)
- ZL-C0-CBL20-2 (2.0 m length)



ZL-RTB20  
20-pin feed-through connector module



# C0-10DRE-D – 8 DC Input/6 Relay Output Micro PLC

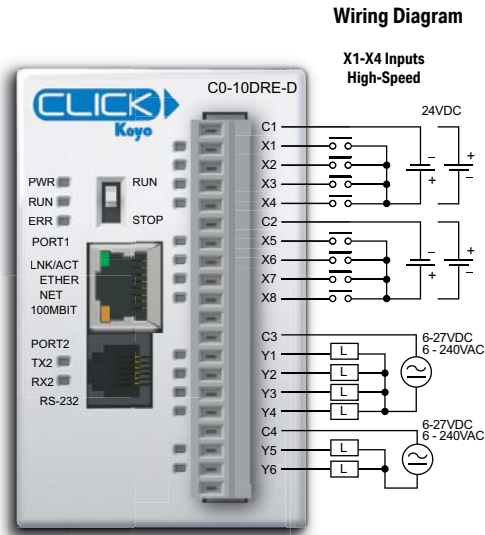

Built-in I/O Specifications - Inputs	
Inputs per Module	8 (Sink/Source)
Operating Voltage Range	24VDC
Input Voltage Range	21.6–26.4 VDC
Input Current	X1-4: Typ 6.5 mA @ 24VDC X5-8: Typ 4mA @ 24VDC
Maximum Input Current	X1-4: 7.0 mA @ 26.4 VDC X5-8: 5.0 mA @ 26.4 VDC
Input Impedance	X1-4: 3.9 kΩ @ 24VDC X5-8: 6.8 kΩ @ 24VDC
Input Frequency (Max)	X1-X4: 100kHz
ON Voltage Level	> 19VDC
OFF Voltage Level	X1-4: < 2VDC X5-8: < 7VDC
Minimum ON Current	X1-4: 4.5 mA X5-8: 3.5 mA
Maximum OFF Current	X1-4: 0.5 mA X5-8: 1.5 mA
OFF to ON Response	X1-4: Typ 3μs Max 5μs X5-8: Typ 2ms Max 10ms
ON to OFF Response	X1-4: Typ 1μs Max 3μs X5-8: Typ 3ms Max 10ms
Status Indicators	Logic Side (8 points, green LED)
Commons	2 (4 points/common) Isolated



**NOTE:** When using Ethernet Basic PLCs, you must use CLICK programming software version V2.00 or later.

General Specifications	
Current Consumption at 24VDC	120mA
Terminal Block Replacement Part No.	C0-16TB
Weight	5.6 oz (160g)

### Equivalent Input Circuit

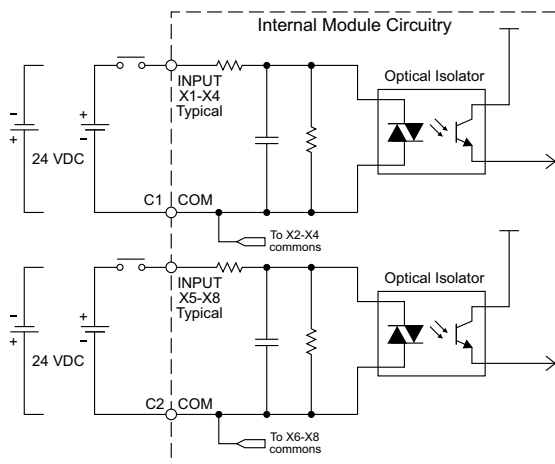

C0-10DRE-D Temperature Derating Chart

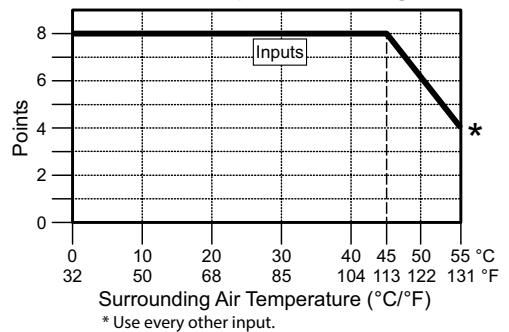

C0-10DRE-D – 8 DC Input/6 Relay Output Micro PLC (continued)

Built-in I/O Specifications - Outputs	
Outputs per Module	6
Operating Voltage Range	6-240 VAC (47-63 Hz), 6-27 VDC
Output Voltage Range	5-264 VAC (47-63 Hz), 5-30 VDC
Output Type	Relay, form A (SPST)
Maximum Current	1 A/point; C3: 4A/common, C4: 2A/common
Minimum Load Current	5mA @ 5 VDC
Maximum Inrush Current	3A for 10ms
OFF to ON Response	< 15ms
ON to OFF Response	< 15ms
Status Indicators	Logic Side (6 points, red LED)
Commons	2 (4 points/com & 2 points/com) Isolated

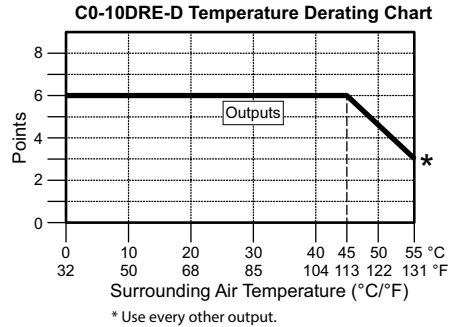

Typical Relay Life (Operations) at Room Temperature	
Voltage & Load Type	Relay Life
30VDC, 1A Resistive	300,000 cycles
30VDC, 1A Solenoid	50,000 cycles
250VAC, 1A Resistive	500,000 cycles
250VAC, 1A Solenoid	200,000 cycles
ON to OFF = 1 cycle	

**ZIPLink Pre-Wired PLC Connection Cables and Modules for CLICK PLC**

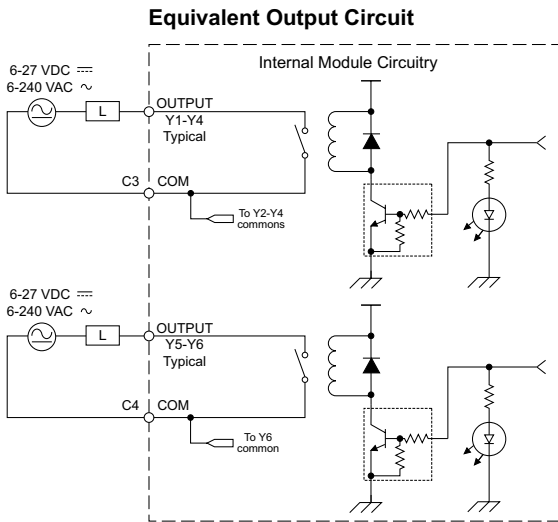

- 20-pin connector cable
- ZL-C0-CBL20 (0.5 m length)
- ZL-C0-CBL20-1 (1.0 m length)
- ZL-C0-CBL20-2 (2.0 m length)



- ZL-RTB20
- 20-pin feed-through connector module



**NOTE:** The C0-10DRE-D is derated to 2A maximum per Common when used with the ZIPLink wiring system.

## C0-10ARE-D – 8 AC Input/6 Relay Output Micro PLC

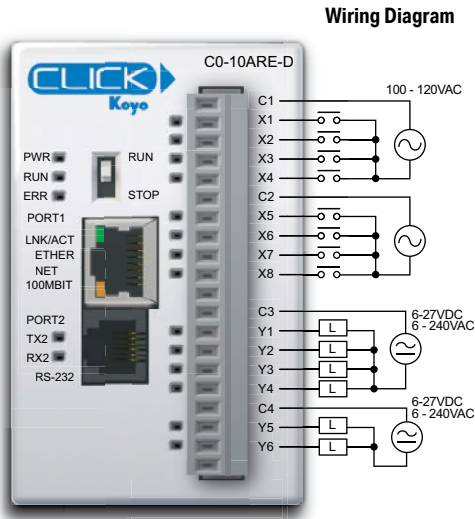

Built-in I/O Specifications - Inputs	
<b>Inputs per Module</b>	8
<b>Operating Voltage Range</b>	100-120 VAC
<b>Input Voltage Range</b>	80-144 VAC
<b>AC Frequency</b>	47-63 Hz
<b>Input Current</b>	8.5 mA @ 100VAC at 50Hz 10mA @ 100VAC at 60Hz
<b>Maximum Input Current</b>	16mA @ 144 VAC at 55°C or 131°F
<b>Input Impedance</b>	15kΩ @ 50Hz 12kΩ @ 60Hz
<b>ON Voltage Level</b>	> 60 VAC
<b>OFF Voltage Level</b>	< 20 VAC
<b>Minimum ON Current</b>	5mA
<b>Maximum OFF Current</b>	2mA
<b>OFF to ON Response</b>	< 40ms
<b>ON to OFF Response</b>	< 40ms
<b>Status Indicators</b>	Logic Side (8 points, green LED)
<b>Commons</b>	2 (4 points/common) Isolated

General Specifications	
<b>Current Consumption at 24VDC</b>	120mA
<b>Terminal Block Replacement Part No.</b>	C0-16TB
<b>Weight</b>	5.6 oz (160g)



**NOTE:** When using Ethernet Basic PLCs, you must use CLICK programming software version V2.00 or later.

### Equivalent Input Circuit

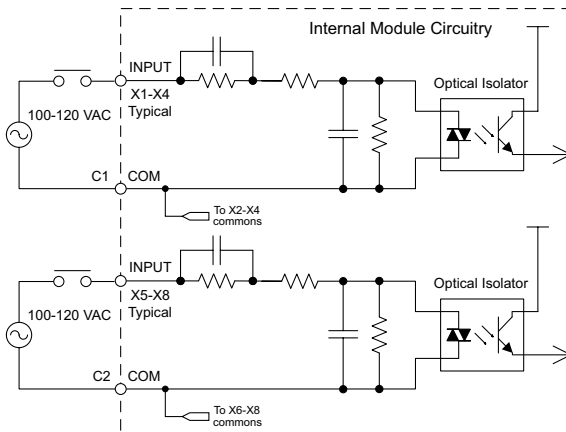

### C0-10ARE-D Temperature Derating Chart

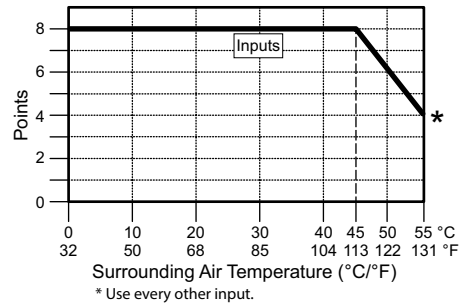

C0-10ARE-D – 8 AC Input/6 Relay Output Micro PLC (continued)

Built-in I/O Specifications - Outputs	
Outputs per Module	6
Operating Voltage Range	6–240 VAC (47–63 Hz), 6–27 VDC
Output Voltage Range	5–264 VAC (47–63 Hz), 5–30 VDC
Output Type	Relay, form A (SPST)
Maximum Current	1 A/point; C3: 4A/common, C4: 2A/common
Minimum Load Current	5mA @ 5VDC
Maximum Inrush Current	3A for 10ms
OFF to ON Response	< 15ms
ON to OFF Response	< 15ms
Status Indicators	Logic Side (6 points, red LED)
Commons	2 (4 points/com & 2 points/com) Isolated

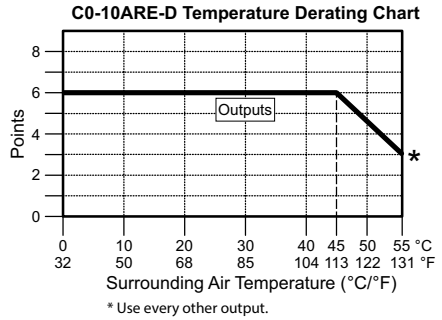

Typical Relay Life (Operations) at Room Temperature	
Voltage & Load Type	Relay Life
30VDC, 1A Resistive	300,000 cycles
30VDC, 1A Solenoid	50,000 cycles
250VAC, 1A Resistive	500,000 cycles
250VAC, 1A Solenoid	200,000 cycles
ON to OFF = 1 cycle	

Equivalent Output Circuit

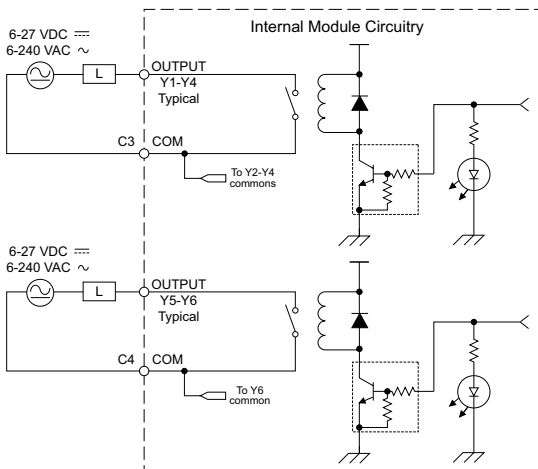

ZIPLink Pre-Wired PLC Connection Cables and Modules for CLICK PLC

- 20-pin connector cable
- ZL-C0-CBL20 (0.5 m length)
- ZL-C0-CBL20-1 (1.0 m length)
- ZL-C0-CBL20-2 (2.0 m length)



- ZL-RTB20
- 20-pin feed-through connector module



**NOTE:** The C0-10ARE-D is derated to 2A maximum per Common when used with the ZIPLink wiring system.

# Ethernet Standard PLC Unit Specifications

## C0-11DD1E-D – 8 DC Input/6 Sinking DC Output Micro PLC

Wiring Diagram

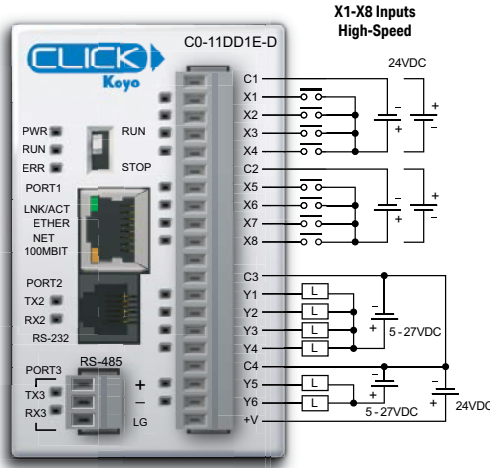

Built-in I/O Specifications - Inputs	
Inputs per Module	8 (Sink/Source)
Operating Voltage Range	24VDC
Input Voltage Range	21.6-26.4 VDC
Input Current	Typ 6.5 mA @ 24VDC
Maximum Input Current	7.0 mA @ 26.4 VDC
Input Impedance	3.9 kΩ @ 24VDC
Input Frequency (Max)	X1-X8: 100kHz
ON Voltage Level	> 19VDC
OFF Voltage Level	< 2VDC
Minimum ON Current	4.5 mA
Maximum OFF Current	0.5 mA
OFF to ON Response	Typ 3μs Max 5μs
ON to OFF Response	Typ 1μs Max 3μs
Status Indicators	Logic Side (8 points, green LED)
Commons	2 (4 points/common) Isolated



**NOTE:** When using Ethernet Standard PLCs, you must use CLICK programming software version V2.00 or later.

General Specifications	
Current Consumption at 24VDC	140mA
Terminal Block Replacement Part No.	C0-16TB
Weight	5.0 oz (140g)

Equivalent Input Circuit

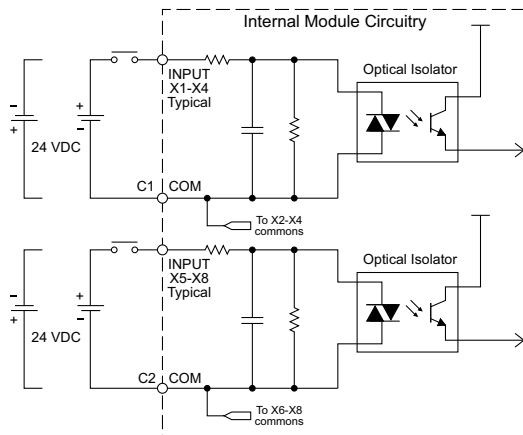

C0-11DD1E-D Temperature Derating Chart

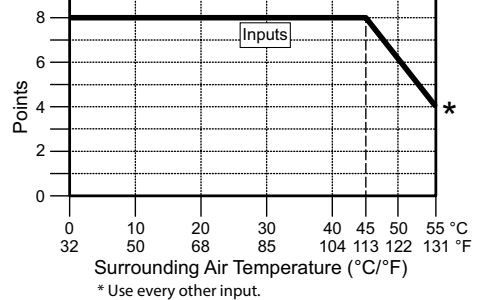

C0-11DDE1-D – 8 DC Input/6 Sinking DC Output Micro PLC (continued)

Built-in I/O Specifications - Outputs	
Outputs per Module	6 (Sink)
Operating Voltage Range	5-27 VDC
Output Voltage Range	4-30 VDC
Maximum Output Current	0.1 A/point; C3: 0.4 A/common, C4: 0.2 A/common
Minimum Output Current	0.2 mA
Maximum Leakage Current	0.1 mA @ 30.0 VDC
On Voltage Drop	0.5 VDC @ 0.1 A
Maximum Inrush Current	150mA for 10ms
OFF to ON Response	Max. 0.5 ms
ON to OFF Response	Max. 0.5 ms
Status Indicators	Logic Side (6 points, red LED)
Commons	2 (4 points/com & 2 points/com)
External DC Power Required	20-28 VDC Maximum @ 60mA (All Points On)

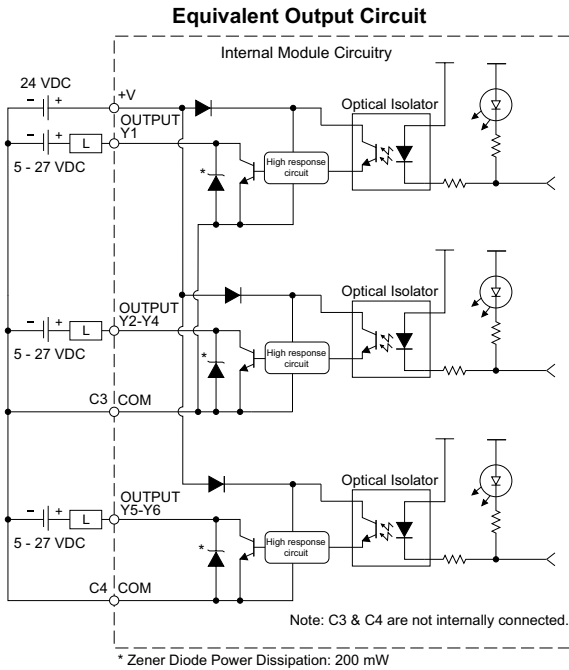
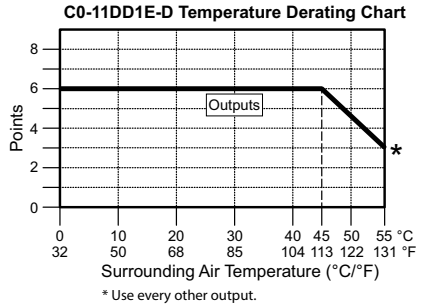

ZIPLink Pre-Wired PLC Connection Cables and Modules for CLICK PLC

- 20-pin connector cable
- ZL-C0-CBL20 (0.5 m length)
- ZL-C0-CBL20-1 (1.0 m length)
- ZL-C0-CBL20-2 (2.0 m length)



- ZL-RTB20
- 20-pin feed-through connector module



# C0-11DD2E-D – 8 DC Input/6 Sourcing DC Output Micro PLC

Wiring Diagram

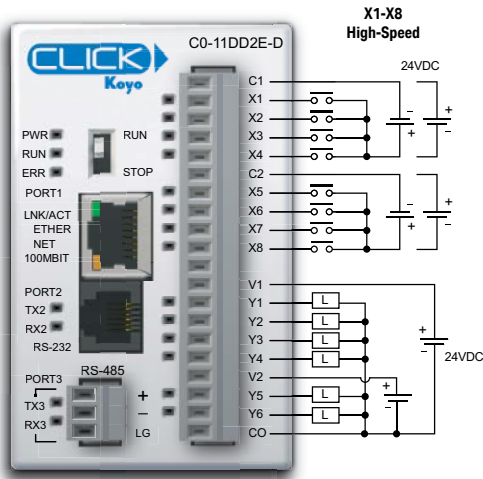

Built-in I/O Specifications - Inputs	
Inputs per Module	8 (Sink/Source)
Operating Voltage Range	24VDC
Input Voltage Range	21.6–26.4 VDC
Input Current	Typ 6.5 mA @ 24VDC
Maximum Input Current	7.0 mA @ 26.4 VDC
Input Impedance	3.9 kΩ @ 24VDC
Input Frequency (Max)	X1-X8: 100kHz
ON Voltage Level	> 19VDC
OFF Voltage Level	< 2VDC
Minimum ON Current	4.5 mA
Maximum OFF Current	0.5 mA
OFF to ON Response	Typ 3μs Max 5μs
ON to OFF Response	Typ 1μs Max 3μs
Status Indicators	Logic Side (8 points, green LED)
Commons	2 (4 points/common) Isolated



**NOTE:** When using Ethernet Standard PLCs, you must use CLICK programming software version V2.00 or later.

General Specifications	
Current Consumption at 24VDC	140mA
Terminal Block Replacement Part No.	C0-16TB
Weight	5.0 oz (140g)

Equivalent Input Circuit

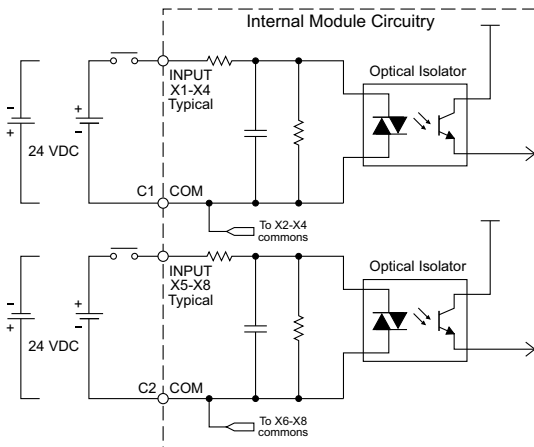

C0-11DD2E-D Temperature Derating Chart

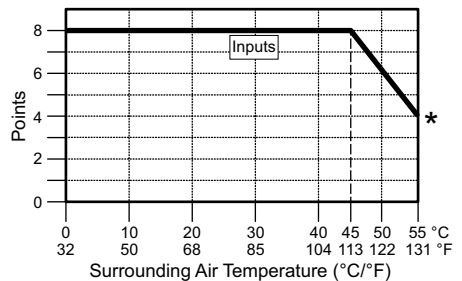

C0-11DD2E-D – 8 DC Input/6 Sourcing DC Output Micro PLC (continued)

Built-in I/O Specifications - Outputs	
Outputs per Module	6 (Source)
Operating Voltage Range	24VDC
Output Voltage Range	19.2-30 VDC
Maximum Output Current	0.1 A/point, 0.6 A/common
Minimum Output Current	0.2 mA
Maximum Leakage Current	0.1 mA @ 30VDC
On Voltage Drop	0.5 VDC @ 0.1 A
Maximum Inrush Current	150mA for 10ms
OFF to ON Response	Max. 0.5 ms
ON to OFF Response	Max. 0.5 ms
Status Indicators	Logic Side (6 points, red LED)
Commons	1 (6 points/common)

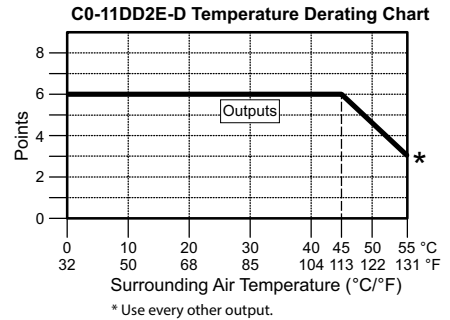

Equivalent Output Circuit

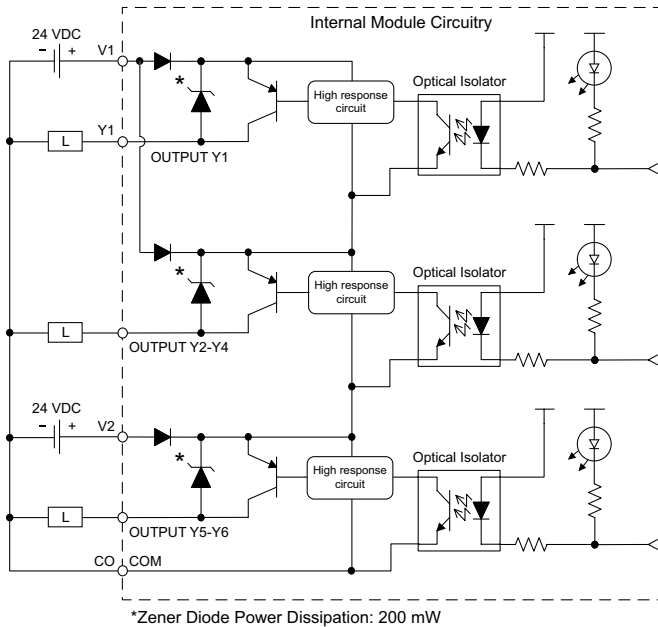

ZIPLink Pre-Wired PLC Connection Cables and Modules for CLICK PLC

- 20-pin connector cable
- ZL-C0-CBL20 (0.5 m length)
- ZL-C0-CBL20-1 (1.0 m length)
- ZL-C0-CBL20-2 (2.0 m length)



- ZL-RTB20
- 20-pin feed-through connector module



# C0-11DRE-D – 8 DC Input/6 Relay Output Micro PLC

## Wiring Diagram

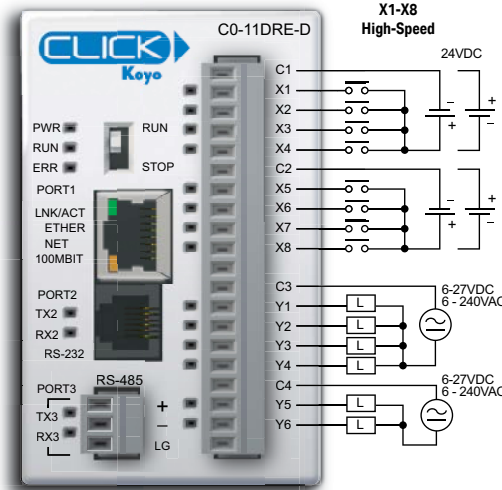

Built-in I/O Specifications - Inputs	
Inputs per Module	8 (Sink/Source)
Operating Voltage Range	24VDC
Input Voltage Range	21.6-26.4 VDC
Input Current	Typ 6.5 mA @ 24VDC
Maximum Input Current	7.0 mA @ 26.4 VDC
Input Impedance	3.9 kΩ @ 24VDC
Input Frequency (Max)	X1-X8: 100kHz
ON Voltage Level	> 19VDC
OFF Voltage Level	< 2VDC
Minimum ON Current	4.5 mA
Maximum OFF Current	0.5 mA
OFF to ON Response	Typ 3μs Max 5μs
ON to OFF Response	Typ 1μs Max 3μs
Status Indicators	Logic Side (8 points, green LED)
Commons	2 (4 points/common) Isolated



**NOTE:** When using Ethernet Standard PLCs, you must use CLICK programming software version V2.00 or later.

General Specifications	
Current Consumption at 24VDC	140mA
Terminal Block Replacement Part No.	C0-16TB
Weight	5.6 oz (160g)

## Equivalent Input Circuit

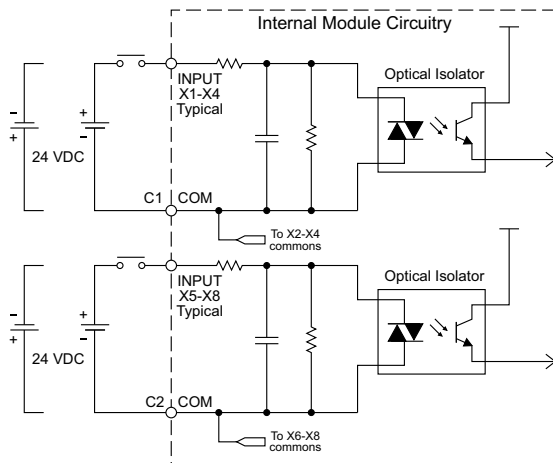

C0-11DRE-D Temperature Derating Chart

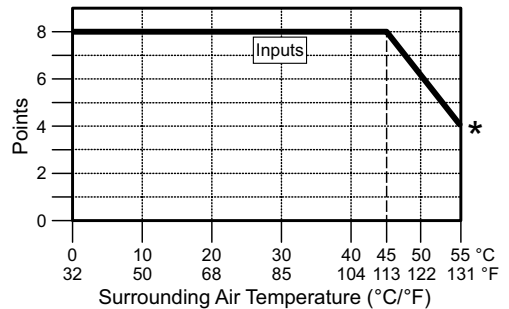

\* Use every other input.

C0-11DRE-D – 8 DC Input/6 Relay Output Micro PLC (continued)

Built-in I/O Specifications - Outputs	
Outputs per Module	6
Operating Voltage Range	6-240 VAC (47-63 Hz), 6-27 VDC
Output Voltage Range	5-264 VAC (47-63 Hz), 5-30 VDC
Output Type	Relay, form A (SPST)
Maximum Current	1A/point; C3: 4A/common, C4: 2A/common
Minimum Load Current	5mA @ 5VDC
Maximum Inrush Current	3A for 10ms
OFF to ON Response	< 15ms
ON to OFF Response	< 15ms
Status Indicators	Logic Side (6 points, red LED)
Commons	2 (4 points/com & 2 points/com) Isolated

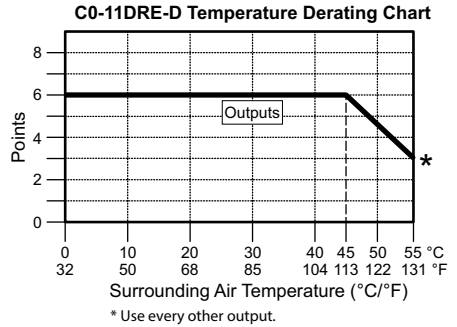

Typical Relay Life (Operations) at Room Temperature	
Voltage & Load Type	Relay Life
30VDC, 1A Resistive	300,000 cycles
30VDC, 1A Solenoid	50,000 cycles
250VAC, 1A Resistive	500,000 cycles
250VAC, 1A Solenoid	200,000 cycles
ON to OFF = 1 cycle	

Equivalent Output Circuit

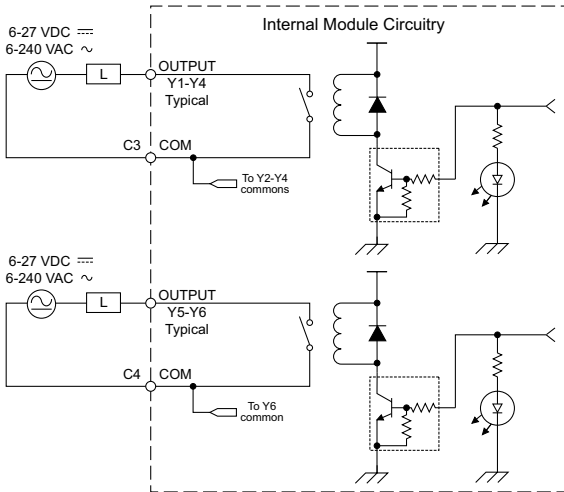

**ZIPLink Pre-Wired PLC Connection Cables and Modules for CLICK PLC**

- 20-pin connector cable
- ZL-C0-CBL20 (0.5 m length)
- ZL-C0-CBL20-1 (1.0 m length)
- ZL-C0-CBL20-2 (2.0 m length)



**ZL-RTB20**  
20-pin feed-through connector module



**NOTE:** The C0-11DRE-D is derated to 2A maximum per Common when used with the ZIPLink wiring system.

## C0-11ARE-D – 8 AC Input/6 Relay Output Micro PLC

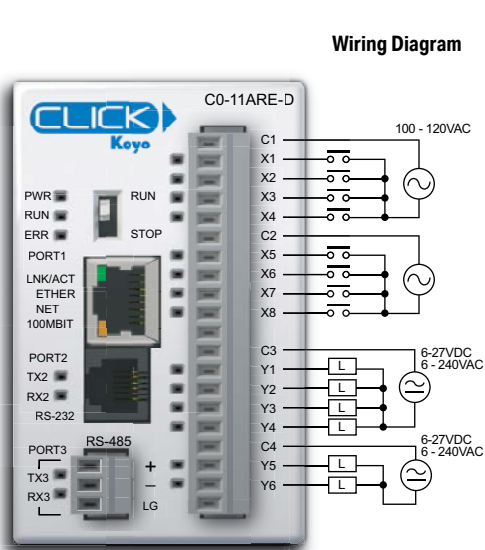

Wiring Diagram

Built-in I/O Specifications - Inputs	
Inputs per Module	8
Operating Voltage Range	100-120 VAC
Input Voltage Range	80-144 VAC
AC Frequency	47-63 Hz
Input Current	8.5 mA @ 100VAC at 50Hz 10mA @ 100VAC at 60Hz
Maximum Input Current	16mA @ 144VAC
Input Impedance	15kΩ @ 50Hz 12kΩ @ 60Hz
ON Voltage Level	> 60VAC
OFF Voltage Level	< 20VAC
Minimum ON Current	5mA
Maximum OFF Current	2mA
OFF to ON Response	< 40ms
ON to OFF Response	< 40ms
Status Indicators	Logic Side (8 points, green LED)
Commons	2 (4 points/common) Isolated



**NOTE:** When using Ethernet Standard PLCs, you must use CLICK programming software version V2.00 or later.

General Specifications	
Current Consumption at 24VDC	140mA
Terminal Block Replacement Part No.	C0-16TB
Weight	5.6 oz (160g)

### Equivalent Input Circuit

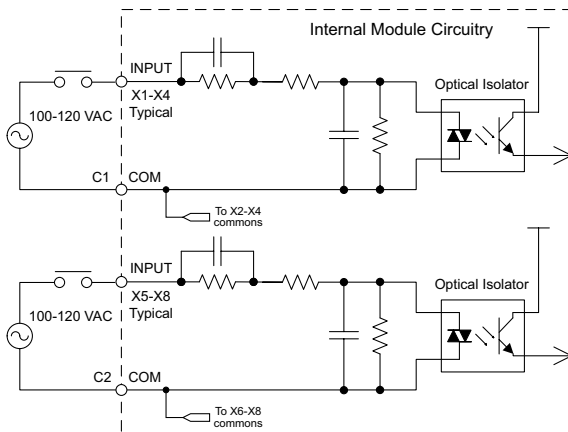

### C0-11ARE-D Temperature Derating Chart

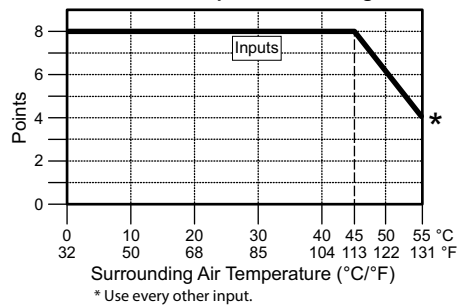

C0-11ARE-D – 8 AC Input/6 Relay Output Micro PLC (continued)

Built-in I/O Specifications - Outputs	
Outputs per Module	6
Operating Voltage Range	6–240 VAC (47–63 Hz), 6–27 VDC
Output Voltage Range	5–264 VAC (47–63 Hz), 5–30 VDC
Output Type	Relay, form A (SPST)
Maximum Current	1A/point; C3: 4A/common, C4: 2A/common
Minimum Load Current	5mA @ 5 VDC
Maximum Inrush Current	3A for 10ms
OFF to ON Response	< 15ms
ON to OFF Response	< 15ms
Status Indicators	Logic Side (6 points, red LED)
Commons	2 (4 points/com & 2 points/com) Isolated

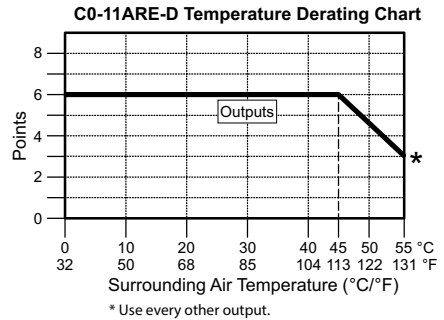

Typical Relay Life (Operations) at Room Temperature	
Voltage & Load Type	Relay Life
30VDC, 1A Resistive	300,000 cycles
30VDC, 1A Solenoid	50,000 cycles
250VAC, 1A Resistive	500,000 cycles
250VAC, 1A Solenoid	200,000 cycles
ON to OFF = 1 cycle	

Equivalent Output Circuit

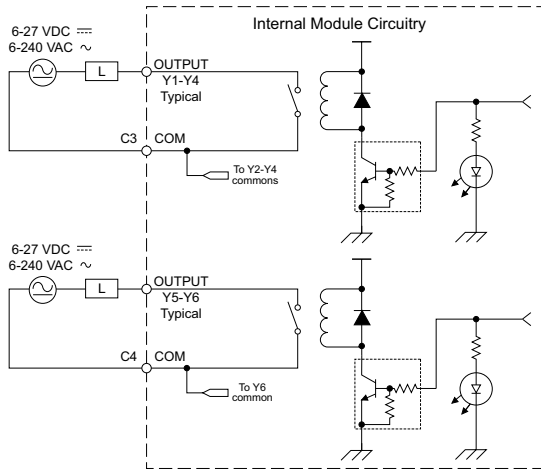

ZIPLink Pre-Wired PLC Connection Cables and Modules for CLICK PLC

- 20-pin connector cable
- ZL-C0-CBL20 (0.5 m length)
- ZL-C0-CBL20-1 (1.0 m length)
- ZL-C0-CBL20-2 (2.0 m length)



ZL-RTB20  
20-pin feed-through connector module



**NOTE:** The C0-11DRE-D is derated to 2A maximum per Common when used with the ZIPLink wiring system.

# Ethernet Analog PLC Unit Specifications

C0-12DD1E-D – 4 DC Input (Sink/Source)/4 Sinking DC Output

2 Analog Voltage/Current Input

2 Analog Voltage/Current Output Micro PLC

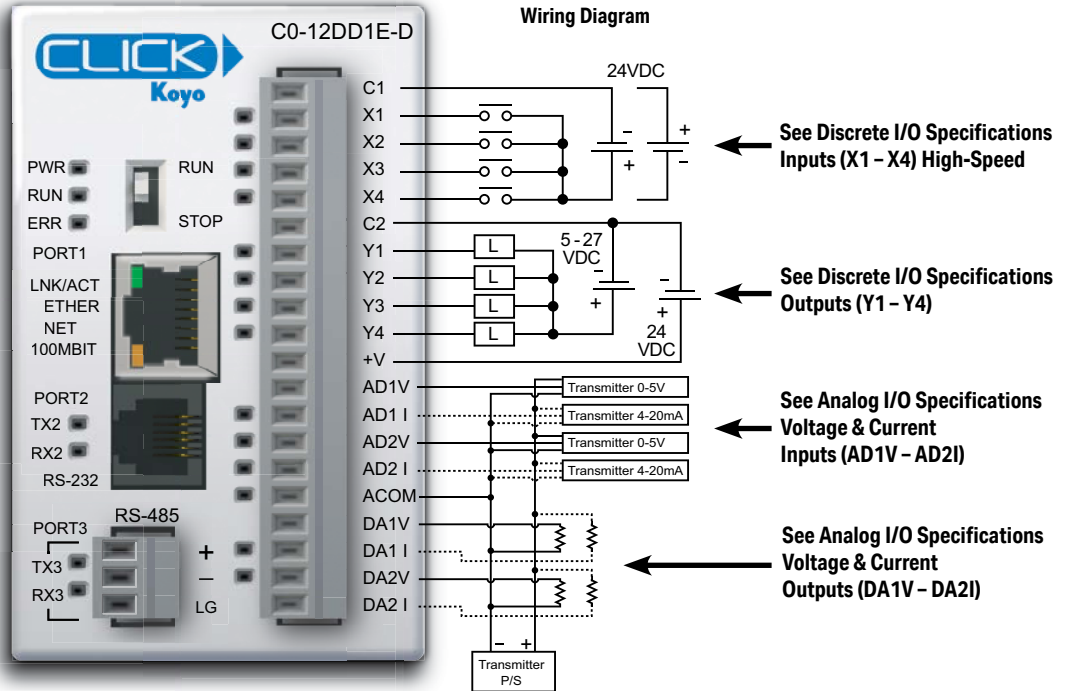

General Specifications	
Current Consumption at 24VDC	140mA
Terminal Block Replacement Part No.	C0-16TB
Weight	5.1 oz (145g)



**WARNING:** When using an Ethernet Analog PLC unit, you must use CLICK programming software version V2.20 or later.



**NOTE:** Please refer to the Analog I/O Configuration section in Chapter 3 for information on using the analog I/O.

**NOTE:** There are no ZIPLink pre-wired PLC connection cables and modules for the Ethernet Analog PLCs (cannot mix discrete I/O and analog I/O signals in a ZIPLink cable).

## C0-12DD1E-D (continued)

### X1 - X4 (High-Speed)

Discrete I/O Specifications - Inputs	
Inputs per Module	4 (Sink/Source)
Operating Voltage Range	24VDC
Input Voltage Range	21.6-26.4 VDC
Input Current	Typ 6.5 mA @ 24VDC
Maximum Input Current	7.0 mA @ 26.4 VDC
Input Impedance	3.9 kΩ @ 24VDC
Input Frequency (Max)	X1-X4: 100kHz
ON Voltage Level	> 19VDC
OFF Voltage Level	< 2VDC
Minimum ON Current	4.5 mA
Maximum OFF Current	0.5 mA
OFF to ON Response	Typ 3μs Max 5μs
ON to OFF Response	Typ 1μs Max 3μs
Status Indicators	Logic Side (4 points, green LED)
Commons	1 (4 points/common)

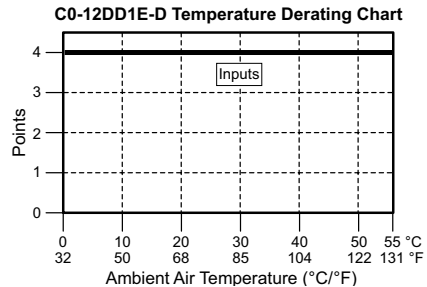
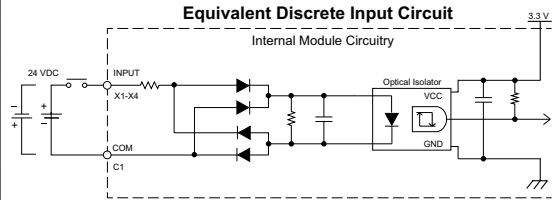

### Y1 - Y4

Discrete I/O Specifications - Outputs	
Outputs per Module	4 (Sink)
Operating Voltage Range	5-27 VDC
Maximum Output Current	0.1 A/point; 0.4 A/common
Minimum Output Current	0.2 mA
Maximum Leakage Current	0.1 mA @ 30.0 VDC
On Voltage Drop	0.5 VDC @ 0.1 A
Maximum Inrush Current	150mA for 10ms
OFF to ON Response	< 5μs
ON to OFF Response	< 5μs
Status Indicators	Logic Side (4 points, red LED)
Commons	1 (4 points/common)
External DC Power Required	20-28 VDC Maximum @ 60mA (All points ON)

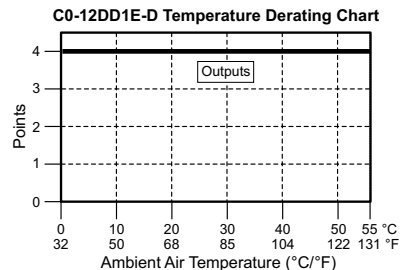
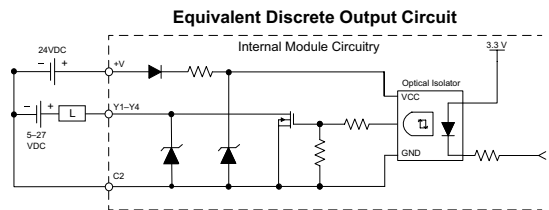

C0-12DD1E-D (continued)

AD1V - AD2I

Analog Specifications - Voltage Input	
Inputs per Module	2 (voltage/current selectable)
Input Range	0-5 VDC (6VDC Max.)
Resolution	12-bit
Conversion Time	50ms
Input Impedance	20kΩ
Input Stability	±2 LSB maximum
Full-Scale Calibration Error	±2% maximum
Offset Calibration Error	±25mV maximum
Accuracy vs. Temperature Error	±100ppm / °C maximum

Analog Specifications - Current Input	
Inputs per Module	2 (voltage/current selectable)
Input Range	4-20 mA (sink)
Resolution	12-bit
Conversion Time	50ms
Input Impedance	125Ω
Input Stability	±2 LSB maximum
Full-Scale Calibration Error	±2% maximum
Offset Calibration Error	±0.1 mA maximum
Accuracy vs. Temperature Error	±100ppm / °C maximum

Analog Voltage Input Circuit

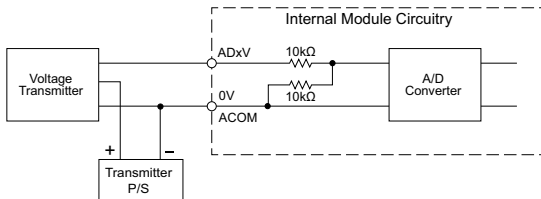

Analog Current Input Circuit

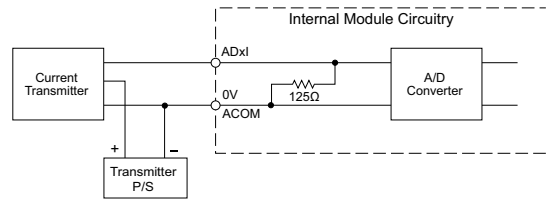

DA1V - DA2I

Analog Specifications - Voltage Output	
Outputs per Module	2 (voltage/current selectable)
Output Range	0-5 VDC
Resolution	12-bit
Conversion Time	1ms
Load Impedance	2kΩ minimum (output current 2.5 mA maximum)
Full-Scale Calibration Error	±2% maximum
Offset Calibration Error	±25mV maximum
Accuracy vs. Temperature Error	±100ppm / °C maximum

Analog Specifications - Current Output	
Outputs per Module	2 (voltage/current selectable)
Output Range	4-20 mA (sink)
Resolution	12-bit
Conversion Time	1ms
Loop Supply Voltage	DC 18-30 V
Load Impedance	250Ω Load Power Supply: DC 18V: 600Ω maximum DC 24V: 900Ω maximum DC 30V: 1200Ω maximum
Full-Scale Calibration Error	±2% maximum
Offset Calibration Error	±25mA maximum
Accuracy vs. Temperature Error	±100ppm / °C maximum

Analog Voltage Output Circuit

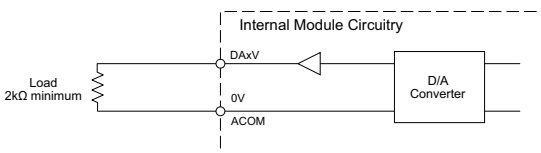

Analog Current Output Circuit

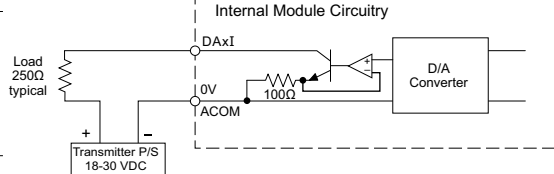

**C0-12DD2E-D – 4 DC Input (Sink/Source)/4 Sourcing DC Output;  
2 Analog Voltage/Current Input  
2 Analog Voltage/Current Output Micro PLC**

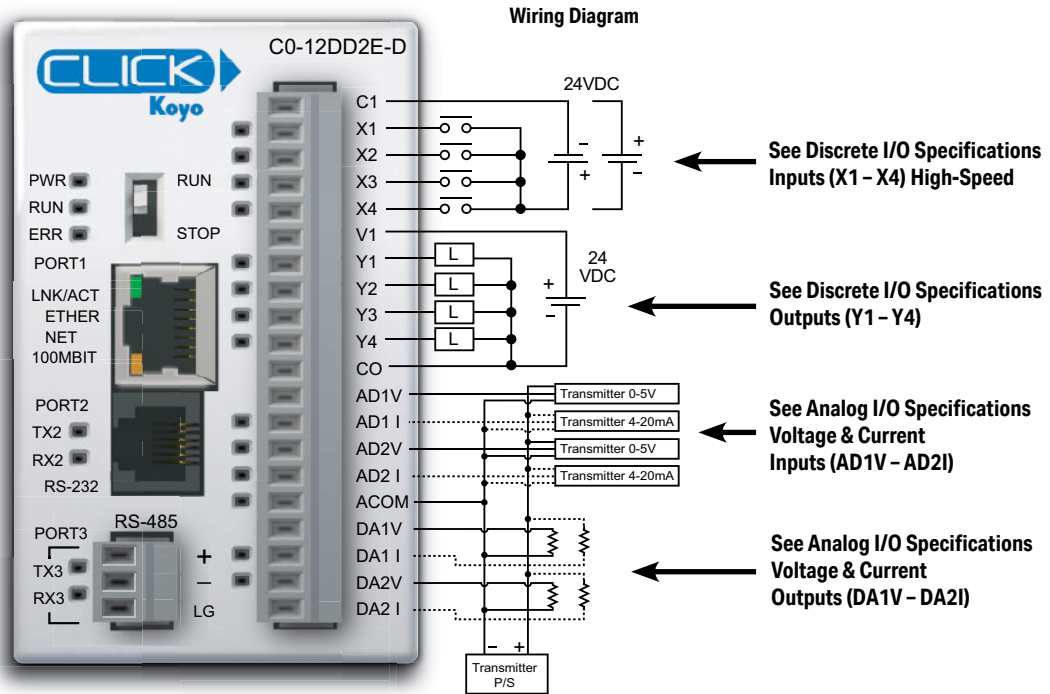

General Specifications	
Current Consumption at 24VDC	140mA
Terminal Block Replacement Part No.	C0-16TB
Weight	5.08 oz (144g)



**WARNING:** When using an Ethernet Analog PLC unit, you must use CLICK programming software version V2.20 or later.

**NOTE:** Please refer to the Analog I/O Configuration section in Chapter 3 for information on using the analog I/O.



**NOTE:** There are no ZIPLink pre-wired PLC connection cables and modules for the Ethernet Analog PLCs (cannot mix discrete I/O and analog I/O signals in a ZIPLink cable).

C0-12DD2E-D (continued)

X1 - X4 (High-Speed)

Discrete I/O Specifications - Inputs	
Inputs per Module	4 (Sink/Source)
Operating Voltage Range	24VDC
Input Voltage Range	21.6–26.4 VDC
Input Current	Typ 6.5 mA @ 24VDC
Maximum Input Current	7mA @ 26.4 VDC
Input Impedance	3.9 kΩ @ 24VDC
Input Frequency (Max)	X1-X4: 100kHz
ON Voltage Level	> 19VDC
OFF Voltage Level	< 2VDC
Minimum ON Current	4.5 mA
Maximum OFF Current	0.5 mA
OFF to ON Response	Typ 3μs, Max 5μs
ON to OFF Response	Typ 1μs, Max 3μs
Status Indicators	Logic Side (4 points, green LED)
Commons	1 (4 points/common)

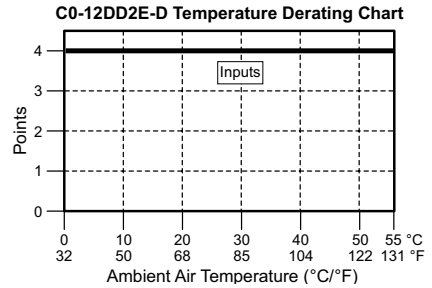
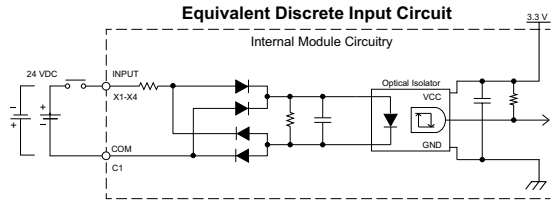

Y1 - Y4

Discrete I/O Specifications - Outputs	
Outputs per Module	4 (Source)
Operating Voltage Range	24VDC
Output Voltage Range	19.2–30 VDC
Maximum Output Current	0.1 A/point , 0.4 A/common
Minimum Output Current	0.2 mA
Maximum Leakage Current	0.1mA @ 30VDC
On Voltage Drop	0.5 VDC@ 0.1 A
Maximum Inrush Current	150mA for 10ms
OFF to ON Response	< 5μs
ON to OFF Response	< 5μs
Status Indicators	Logic Side (4 points, red LED)
Commons	1 (4 points/common)

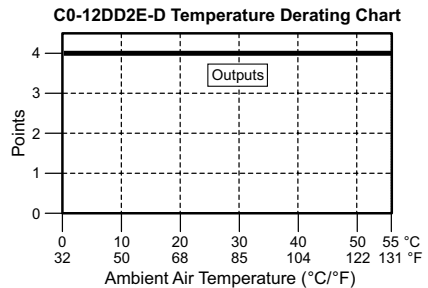
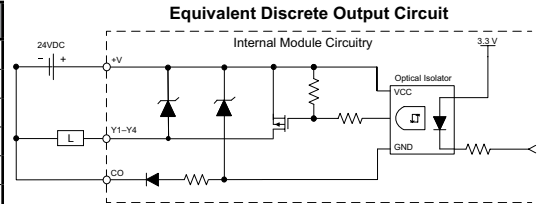

C0-12DD2E-D (continued)

AD1V - AD2I

Analog Specifications - Voltage Input	
Inputs per Module	2 (voltage/current selectable)
Input Range	0-5 VDC
Resolution	12-bit
Conversion Time	50ms
Input Impedance	20kΩ
Input Stability	±2 LSB maximum
Full-Scale Calibration Error	±2% maximum
Offset Calibration Error	±25mV maximum
Accuracy vs. Temperature Error	±100ppm / °C maximum

Analog Voltage Input Circuit

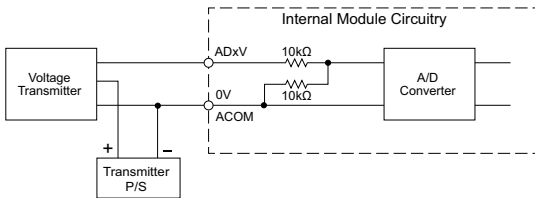

Analog Specifications - Current Input	
Inputs per Module	2 (voltage/current selectable)
Input Range	4-20 mA (sink)
Resolution	12-bit
Conversion Time	50ms
Input Impedance	125Ω
Input Stability	±2 LSB maximum
Full-Scale Calibration Error	±2% maximum
Offset Calibration Error	±0.1 mA maximum
Accuracy vs. Temperature Error	Less than ±100ppm / °C

Analog Current Input Circuit

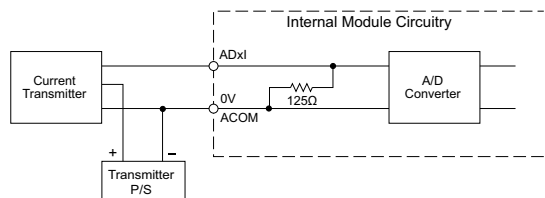

DA1V - DA2I

Analog Specifications - Voltage Output	
Outputs per Module	2 (voltage/current selectable)
Output Range	0-5 VDC
Resolution	12-bit
Conversion Time	1ms
Load Impedance	2kΩ minimum (output current 2.5 mA maximum)
Full-Scale Calibration Error	±2% maximum
Offset Calibration Error	±25mV maximum
Accuracy vs. Temperature Error	±100ppm / °C maximum

Analog Voltage Output Circuit

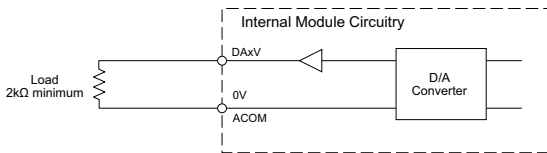

Analog Specifications - Current Output	
Outputs per Module	2 (voltage/current selectable)
Output Range	4-20 mA (sink)
Resolution	12-bit
Conversion Time	1ms
Loop Supply Voltage	DC 18-30 V
Load Impedance	250Ω Load Power Supply: DC 18V: 600Ω maximum DC 24V: 900Ω maximum DC 30V: 1200Ω maximum
Full-Scale Calibration Error	±2% maximum
Offset Calibration Error	±25mA maximum
Accuracy vs. Temperature Error	±100ppm / °C maximum

Analog Current Output Circuit

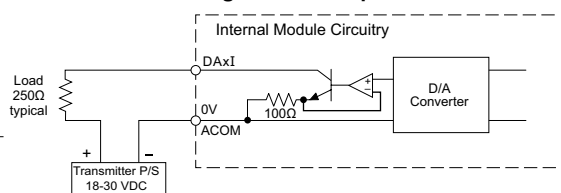

**C0-12DRE-D – 4 DC Input (Sink/Source)/4 Relay Output;**

**2 Analog Voltage/Current Input**

**2 Analog Voltage/Current Output Micro PLC**

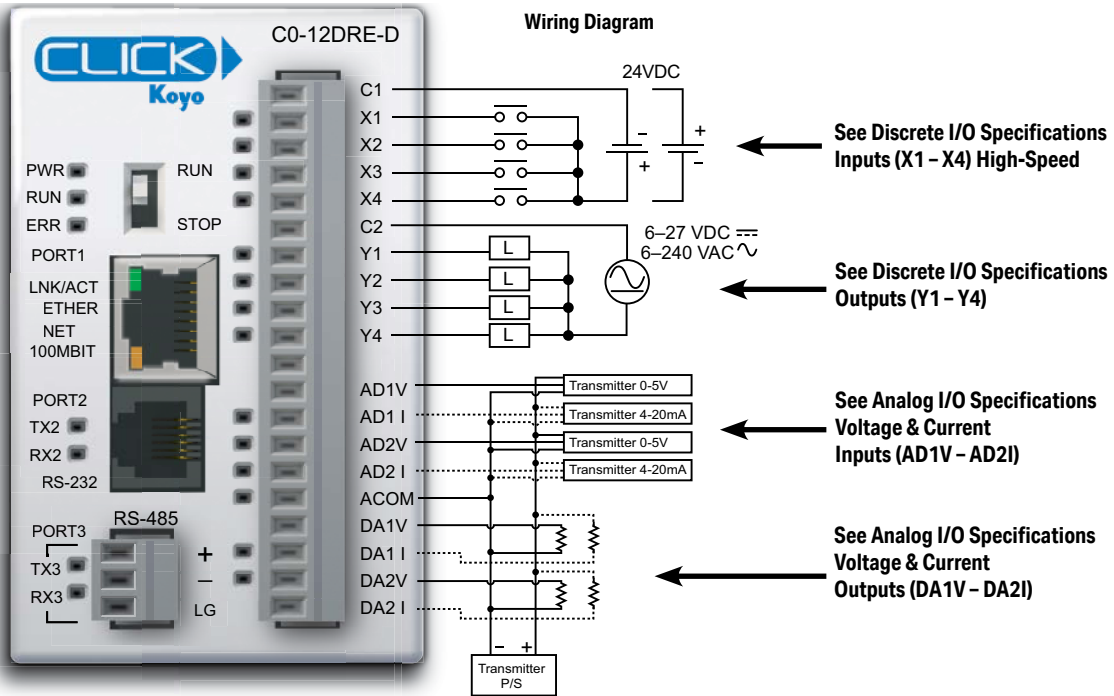

General Specifications	
Current Consumption at 24VDC	160mA
Terminal Block Replacement Part No.	C0-16TB
Weight	5.4 oz (155g)



**WARNING:** When using an Ethernet Analog PLC unit, you must use CLICK programming software version V2.20 or later.

**NOTE:** Please refer to the Analog I/O Configuration section in Chapter 3 for information on using the analog I/O.



**NOTE:** There are no ZIPLink pre-wired PLC connection cables and modules for the Ethernet Analog PLCs (cannot mix discrete I/O and analog I/O signals in a ZIPLink cable).

## C0-12DRE-D (continued)

### X1 - X4 (High-Speed)

Discrete I/O Specifications - Inputs	
Inputs per Module	4 (Source/Sink)
Operating Voltage Range	24VDC
Input Voltage Range	21.6-26.4 VDC
Input Current	Typ 6.5 mA @ 24VDC
Input Impedance	3.9 kΩ @ 24 VDC
Input Frequency (Max)	X1-X4: 100kHz
ON Voltage Level	> 19VDC
OFF Voltage Level	< 2VDC
Minimum ON Current	4.5 mA
Maximum OFF Current	0.5 mA
OFF to ON Response	Typ 3μs, Max 5μs
ON to OFF Response	Typ 1μs, Max 3μs
Status Indicators	Logic Side (4 points, green LED)
Commons	1 (4 points/common)

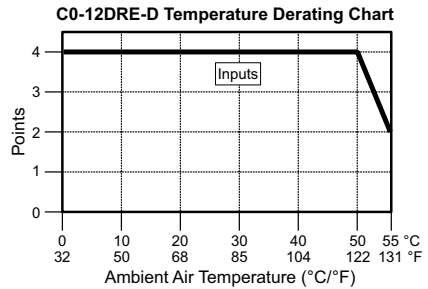
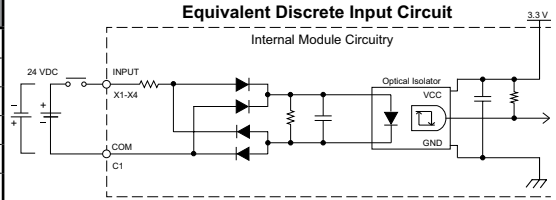

### Y1 - Y4

Discrete I/O Specifications - Outputs	
Outputs per Module	4
Operating Voltage Range	6-27 VDC / 6-240 VAC
Output Type	Relay, form A (SPST)
AC Frequency	47-63 Hz
Maximum Current	1A/point (resistive)
Minimum Load Current	5mA @ 5VDC
Maximum Inrush Current	3A for 10ms
OFF to ON Response	< 15ms
ON to OFF Response	< 15ms
Status Indicators	Logic Side (4 points, red LED)
Commons per Module	1 (4 points/common)

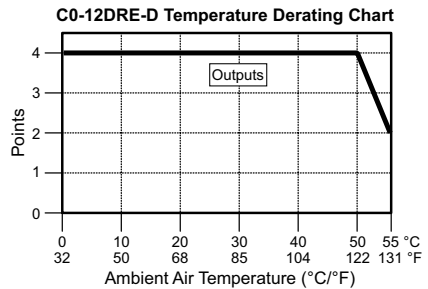
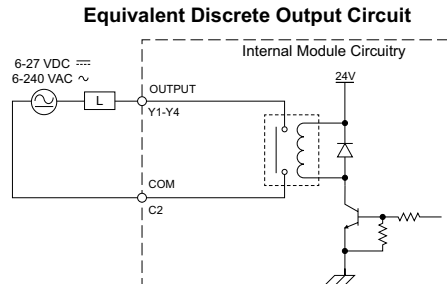

Typical Relay Life (Operations) at Room Temperature	
Voltage & Load Type	Relay Life
30VDC, 1A Resistive	300,000 cycles
30VDC, 1A Solenoid	50,000 cycles
120VAC, 1A Resistive	500,000 cycles
120VAC, 1A Solenoid	200,000 cycles
ON to OFF = 1 cycle	

C0-12DRE-D (continued)

AD1V - AD2I

Analog Specifications - Voltage Input	
Inputs per Module	2 (voltage/current selectable)
Input Range	0-5 VDC (6VDC Max.)
Resolution	12-bit
Conversion Time	50ms
Input Impedance	20kΩ
Input Stability	±2 LSB maximum
Full-Scale Calibration Error	±2% maximum
Offset Calibration Error	±25mV maximum
Accuracy vs. Temperature Error	±100ppm / °C maximum

Analog Specifications - Current Input	
Inputs per Module	2 (voltage/current selectable)
Input Range	4-20 mA (sink)
Resolution	12-bit
Conversion Time	50ms
Input Impedance	125Ω
Input Stability	±2 LSB maximum
Full-Scale Calibration Error	±2% maximum
Offset Calibration Error	±0.1 mA maximum
Accuracy vs. Temperature Error	±100ppm / °C maximum

Analog Voltage Input Circuit

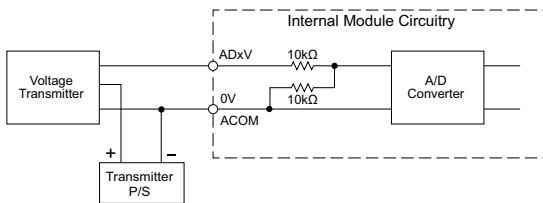

Analog Current Input Circuit

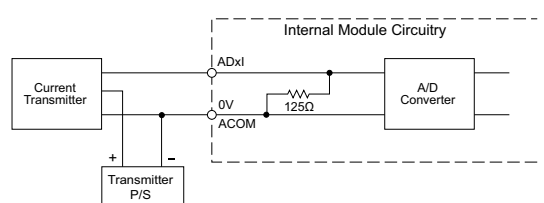

DA1V - DA2I

Analog Specifications - Voltage Output	
Outputs per Module	2 (voltage/current selectable)
Output Range	0-5 VDC
Resolution	12-bit
Conversion Time	1ms
Load Impedance	2kΩ minimum (output current 2.5 mA maximum)
Full-Scale Calibration Error	±2% maximum
Offset Calibration Error	±25mV maximum
Accuracy vs. Temperature Error	±100ppm / °C maximum

Analog Specifications - Current Output	
Outputs per Module	2 (voltage/current selectable)
Output Range	4-20 mA (sink)
Resolution	12-bit
Conversion Time	1ms
Loop Supply Voltage	DC 18-30 V
Load Impedance	250Ω Load Power Supply: DC 18V: 600Ω maximum DC 24V: 900Ω maximum DC 30V: 1200Ω maximum
Full-Scale Calibration Error	±2% maximum
Offset Calibration Error	±25mA maximum
Accuracy vs. Temperature Error	±100ppm / °C maximum

Analog Voltage Output Circuit

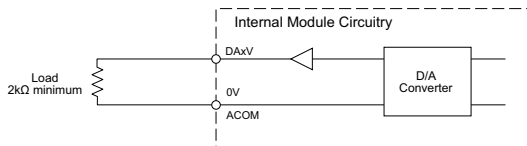

Analog Current Output Circuit

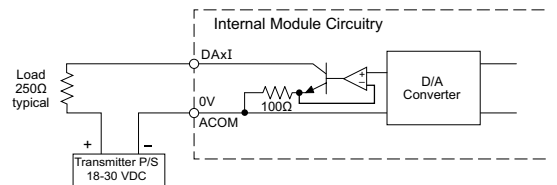

C0-12ARE-D – 4 AC Input/4 Relay Output;

2 Analog Voltage/Current Input

2 Analog Voltage/Current Output Micro PLC

Wiring Diagram

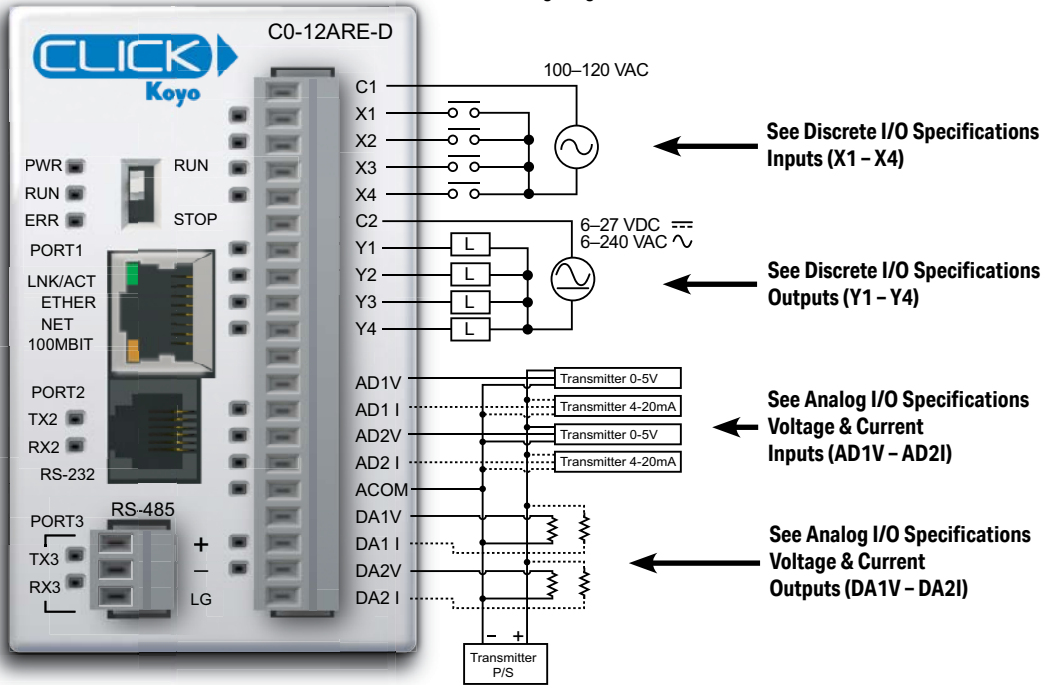

General Specifications	
Current Consumption at 24VDC	160mA
Terminal Block Replacement Part No.	C0-16TB
Weight	5.4 oz (154g)



**WARNING:** When using an Ethernet Analog PLC unit, you must use CLICK programming software version V2.20 or later.

**NOTE:** Please refer to the Analog I/O Configuration section in Chapter 3 for information on using the analog I/O.



**NOTE:** There are no ZIPLink pre-wired PLC connection cables and modules for the Ethernet Analog PLCs (cannot mix discrete I/O and analog I/O signals in a ZIPLink cable).

C0-12ARE-D (continued)

X1 - X4

Discrete I/O Specifications - Inputs	
Inputs per Module	4
Operating Voltage Range	100-120 VAC
AC Frequency	47-63 Hz
Input Current	Typ 8.5 mA @ 100VAC (50Hz) Typ 10mA @100VAC (60Hz)
Max. Input Current	16mA @ 144VAC
Input Impedance	15kΩ @ 50Hz 12kΩ @ 60Hz
ON Voltage Level	> 60VAC
OFF Voltage Level	< 20VAC
Minimum ON Current	5mA
Maximum OFF Current	2mA
OFF to ON Response	< 40ms
ON to OFF Response	< 40ms
Status Indicators	Logic Side (4 points, green LED)
Commons	1 (4 points/common)

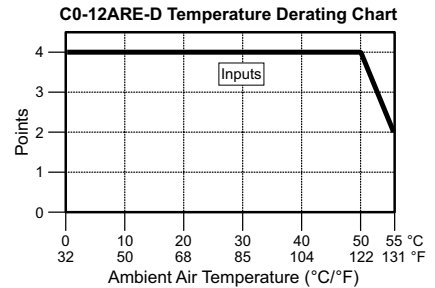
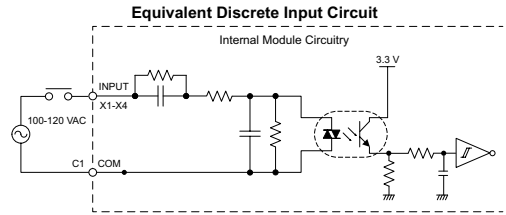

Y1 - Y4

Discrete I/O Specifications - Outputs	
Outputs per Module	4
Operating Voltage Range	6-27 VDC, 6-240 VAC
Output Type	Relay, form A (SPST)
AC Frequency	47-63 Hz
Maximum Current	1A/point (resistive)
Minimum Load Current	5mA @ 5VDC
Maximum Inrush Current	3A for 10ms
OFF to ON Response	< 15ms
ON to OFF Response	< 15ms
Status Indicators	Logic Side (4 points, red LED)
Commons per Module	1 (4 points/common)

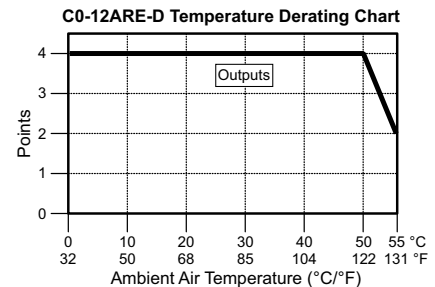
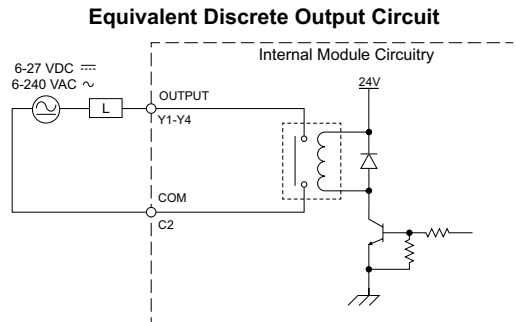

Typical Relay Life (Operations) at Room Temperature	
Voltage & Load Type	Relay Life
30VDC, 1A Resistive	300,000 cycles
30VDC, 1A Solenoid	50,000 cycles
120VAC, 1A Resistive	500,000 cycles
120VAC, 1A Solenoid	200,000 cycles
ON to OFF = 1 cycle	

## C0-12ARE-D (continued)

### AD1V - AD2V

Analog Specifications - Voltage Input	
Inputs per Module	2 (voltage/current selectable)
Input Range	0–5 VDC (6VDC Max.)
Resolution	12-bit
Conversion Time	50ms
Input Impedance	20kΩ
Input Stability	±2 LSB maximum
Full-Scale Calibration Error	±2% maximum
Offset Calibration Error	±25mV maximum
Accuracy vs. Temperature Error	±100ppm / °C maximum

Analog Voltage Input Circuit

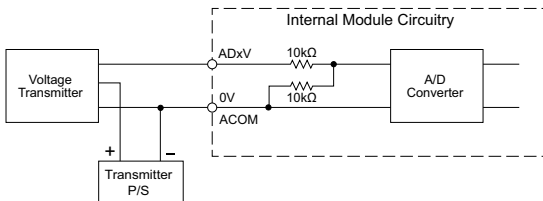

### AD1I - AD2I

Analog Specifications - Current Input	
Inputs per Module	2 (voltage/current selectable)
Input Range	4–20 mA (sink)
Resolution	12-bit
Conversion Time	50ms
Input Impedance	125Ω
Input Stability	±2 LSB maximum
Full-Scale Calibration Error	±2% maximum
Offset Calibration Error	±0.1 mA maximum
Accuracy vs. Temperature Error	±100ppm / °C maximum

Analog Current Input Circuit

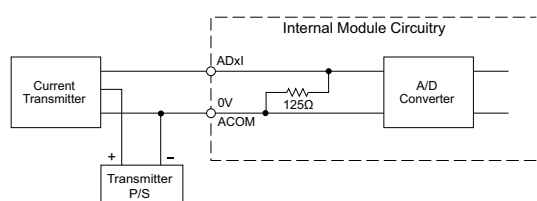

### DA1V - DA2V

Analog Specifications - Voltage Output	
Outputs per Module	2 (voltage/current selectable)
Output Range	0–5 VDC
Resolution	12-bit
Conversion Time	1ms
Load Impedance	2kΩ minimum (output current 2.5 mA maximum)
Full-Scale Calibration Error	±2% maximum
Offset Calibration Error	±25mV maximum
Accuracy vs. Temperature Error	±100ppm / °C maximum

Analog Voltage Output Circuit

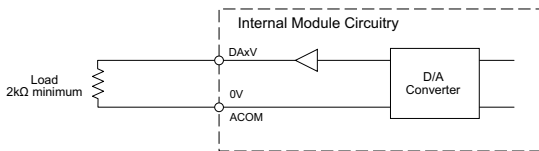

### DA1I - DA2I

Analog Specifications - Current Output	
Outputs per Module	2 (voltage/current selectable)
Output Range	4–20 mA (sink)
Resolution	12-bit
Conversion Time	1ms
Loop Supply Voltage	DC 18–30 V
Load Impedance	250Ω Load Power Supply: DC 18V: 600Ω maximum DC 24V: 900Ω maximum DC 30V: 1200Ω maximum
Full-Scale Calibration Error	±2% maximum
Offset Calibration Error	±25mA maximum
Accuracy vs. Temperature Error	±100ppm / °C maximum

Analog Current Output Circuit

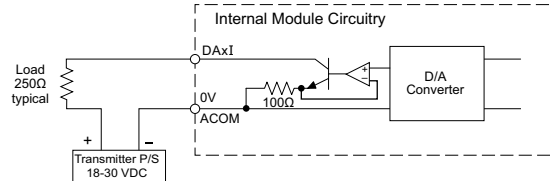

**C0-12DD1E-1-D – 4 DC Input (Sink/Source)/4 Sinking DC Output;  
4 Analog Current Input  
2 Analog Current Output Micro PLC**

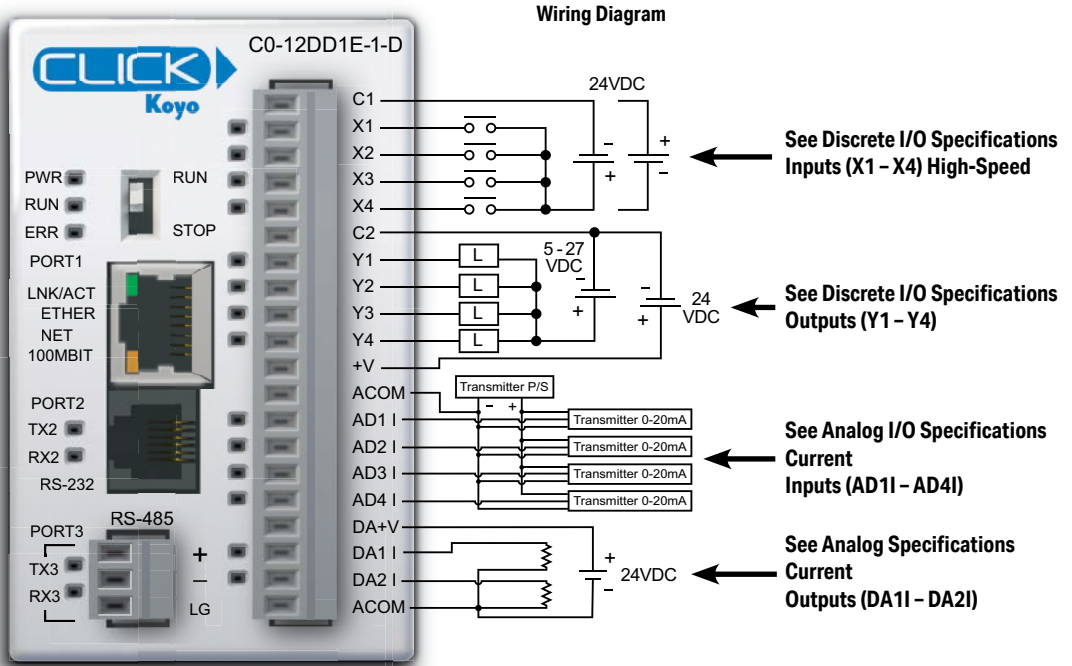

General Specifications	
Current Consumption at 24VDC	140mA
Terminal Block Replacement Part No.	C0-16TB
Weight	5.08 oz (144g)



**WARNING:** When using an Ethernet Analog PLC unit, you must use CLICK programming software version V2.20 or later.

**NOTE:** Please refer to the Analog I/O Configuration section in Chapter 3 for information on using the analog I/O.



**NOTE:** There are no ZIPLink pre-wired PLC connection cables and modules for the Ethernet Analog PLCs (cannot mix discrete I/O and analog I/O signals in a ZIPLink cable).

C0-12DD1E-1-D (continued)

X1 - X4 (High-Speed)

Discrete I/O Specifications - Inputs	
Inputs per Module	4 (Sink/Source)
Operating Voltage Range	24VDC
Input Voltage Range	21.6-26.4 VDC
Input Current	Typ 6.5 mA @ 24VDC
Maximum Input Current	7mA @ 26.4 VDC
Input Impedance	3.9 kΩ @ 24VDC
Input Frequency (Max)	X1-X4: 100kHz
ON Voltage Level	>19VDC
OFF Voltage Level	< 2VDC
Minimum ON Current	4.5 mA
Maximum OFF Current	0.5 mA
OFF to ON Response	Typ 3μs Max 5μs
ON to OFF Response	Typ 1μs Max 3μs
Status Indicators	Logic Side (4 points, green LED)
Commons	1 (4 points/common)

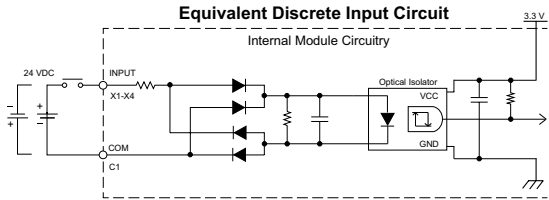

C0-12DD1E-1-D Temperature Derating Chart

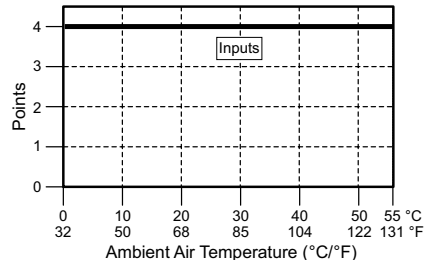

Y1 - Y4

Discrete I/O Specifications - Outputs	
Outputs per Module	4 (Sink)
Operating Voltage Range	5-27 VDC
Maximum Output Current	0.1 A/point; 0.4 A/common
Minimum Output Current	0.2 mA
Maximum Leakage Current	0.1 mA @ 30.0 VDC
On Voltage Drop	0.5 VDC @ 0.1 A
Maximum Inrush Current	150mA for 10ms
OFF to ON Response	< 5μs
ON to OFF Response	< 5μs
Status Indicators	Logic Side (4 points, red LED)
Commons	1 (4 points/common)
External DC Power Required	20-28 VDC Maximum @ 60mA (All points on)

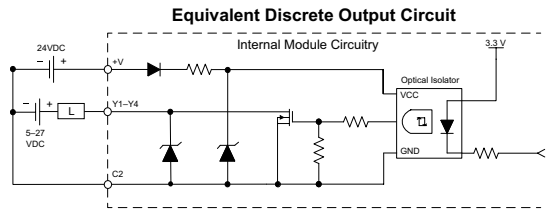

C0-12DD1E-1-D Temperature Derating Chart

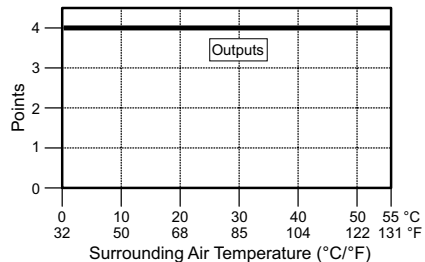

C0-12DD1E-1-D (continued)

AD1I - AD4I

Analog Specifications - Current Input	
Inputs per Module	4 (current)
Input Range	0-20 mA (sink)
Resolution	12-bit
Conversion Time	50ms
Input Impedance	125Ω
Input Stability	±2 LSB maximum
Full-Scale Calibration Error	±2% maximum
Offset Calibration Error	±0.1 mA maximum
Accuracy vs. Temperature Error	±120ppm / °C maximum

Analog Current Input Circuit

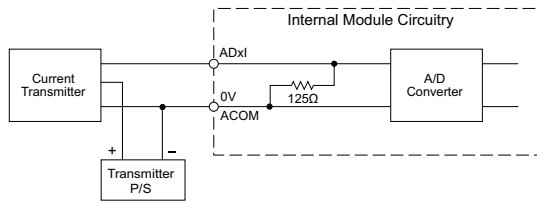

DA1I - DA2I

Analog Specifications - Current Output	
Outputs per Module	2 (current)
Output Range	4-20 mA (source)
Resolution	12-bit
Conversion Time	2.5 ms
Load Impedance	250Ω TYP (200-800 Ω)
Loop Supply Voltage	DC 24V TYP (21.6-26.4 VDC)
Full-Scale Calibration Error	±2% maximum
Offset Calibration Error	±25mA maximum
Accuracy vs. Temperature Error	±120ppm / °C maximum
External DC Power Required	21.6-26.4 VDC

Analog Current Output Circuit

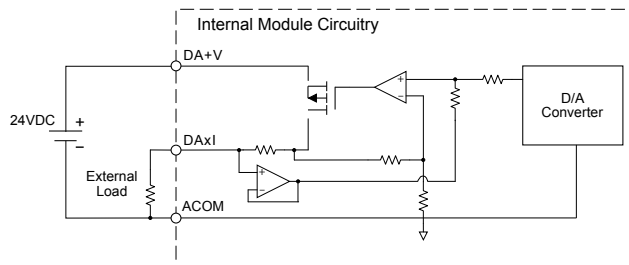

**C0-12DD2E-1-D – 4 DC Input (Sink/Source)/4 Sourcing DC Output;  
4 Analog Current Input  
2 Analog Current Output Micro PLC**

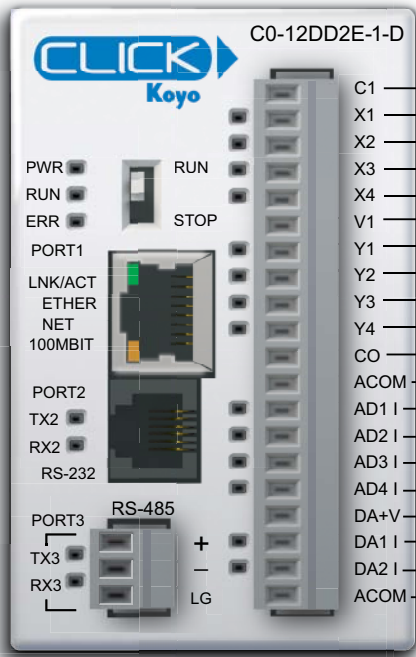

Wiring Diagram

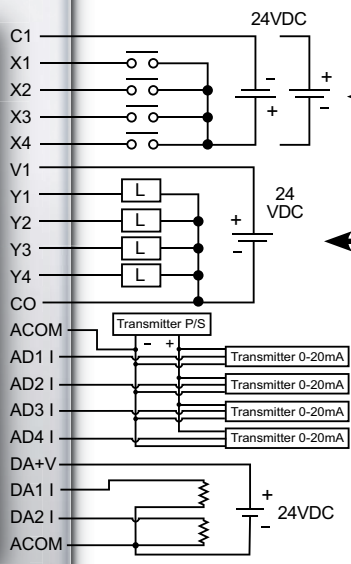

See Discrete I/O Specifications  
Inputs (X1 - X4) High-Speed

See Discrete I/O Specifications  
Outputs (Y1 - Y4)

See Analog I/O Specifications  
Current  
Input (AD1I - AD4I)

See Analog I/O Specifications  
Current  
Output (DA1I - DA2I)

General Specifications	
Current Consumption at 24VDC	140mA
Terminal Block Replacement Part No.	C0-16TB
Weight	5.08 oz (144g)



**WARNING:** When using an Ethernet Analog PLC unit, you must use CLICK programming software version V2.20 or later.

**NOTE:** Please refer to the Analog I/O Configuration section in Chapter 3 for information on using the analog I/O.

**NOTE:** There are no ZIPLink pre-wired PLC connection cables and modules for the Ethernet Analog PLCs (cannot mix discrete I/O and analog I/O signals in a ZIPLink cable).

C0-12DD2E-1-D (continued)

X1 - X4 (High-Speed)

Discrete I/O Specifications - Inputs	
Inputs per Module	4 (Sink/Source)
Operating Voltage Range	24VDC
Input Voltage Range	21.6-26.4 VDC
Input Current	Typ 6.5 mA @ 24VDC
Maximum Input Current	7mA @ 26.4 VDC
Input Impedance	3.9 kΩ @ 24VDC
Input Frequency (Max)	X1-X4: 100kHz
ON Voltage Level	>19VDC
OFF Voltage Level	< 2VDC
Minimum ON Current	4.5 mA
Maximum OFF Current	0.5 mA
OFF to ON Response	Typ 3μs Max 5μs
ON to OFF Response	Typ 1μs Max 3μs
Status Indicators	Logic Side (4 points, green LED)
Commons	1 (4 points/common)

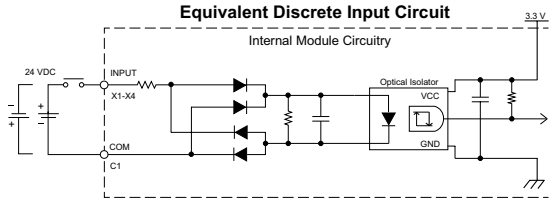

C0-12DD2E-1-D Temperature Derating Chart

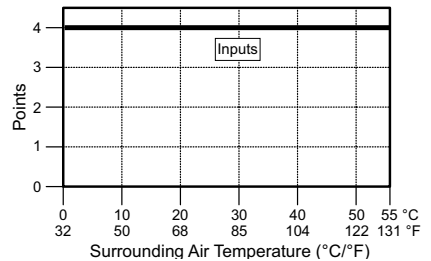

Y1 - Y4

Discrete I/O Specifications - Outputs	
Outputs per Module	4 (Source)
Operating Voltage Range	19.2-30 VDC
Maximum Output Current	0.1 A/point; 0.4 A/common C0
Minimum Output Current	0.2 mA
Maximum Leakage Current	0.1 mA @ 30.0 VDC
On Voltage Drop	0.5 VDC @ 0.1 A
Maximum Inrush Current	150mA for 10ms
OFF to ON Response	< 5μs
ON to OFF Response	< 5μs
Status Indicators	Logic side (4 points, red LED)
Commons	1 (4 points/common)

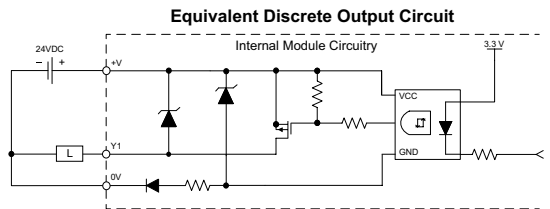

C0-12DD2E-1-D Temperature Derating Chart

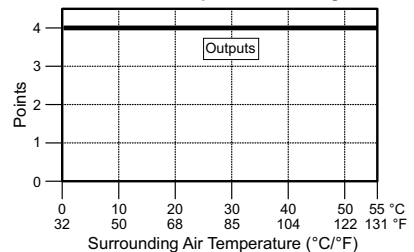

C0-12DD2E-1-D (continued)

AD1I - AD4I

Analog Specifications - Current Input	
Inputs per Module	4 (current)
Input Range	0-20 mA (sink)
Resolution	12-bit
Conversion Time	50ms
Input Impedance	125Ω
Input Stability	±2 LSB maximum
Full-Scale Calibration Error	±2% maximum
Offset Calibration Error	±0.1 mA maximum
Accuracy vs. Temperature Error	±100ppm / °C maximum

Analog Current Input Circuit

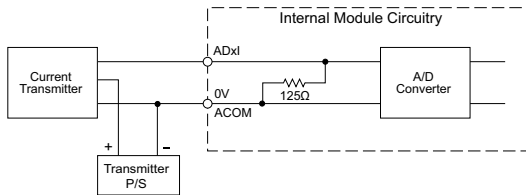

DA1I - DA2I

Analog Specifications - Current Output	
Outputs per Module	2 (current)
Output Range	4-20 mA (source)
Resolution	12-bit
Conversion Time	2.5 ms
Load Impedance	250Ω Typ (200Ω to 800Ω)
Loop Supply Voltage	24VDC Typ (21.6-26.4 VDC)
Full-Scale Calibration Error	±2% maximum
Offset Calibration Error	±25mA maximum
Accuracy vs. Temperature Error	±120ppm / °C maximum
External DC Power Required	21.6-26.4 VDC

Analog Current Output Circuit

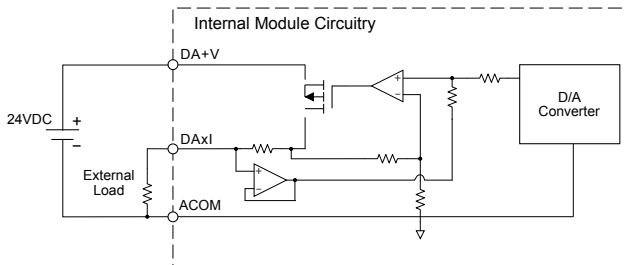

**C0-12DRE-1-D – 4 DC Input (Sink/Source)/4 Relay Output;**

**4 Analog Current Input**

**2 Analog Current Output Micro PLC**

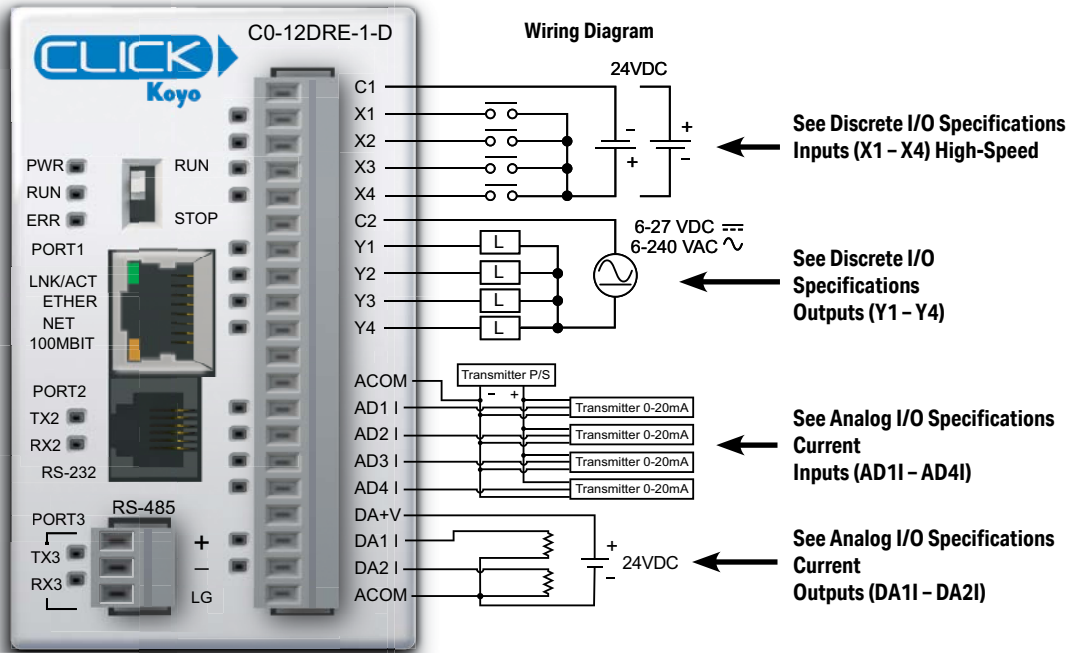

General Specifications	
Current Consumption at 24VDC	160mA
Terminal Block Replacement Part No.	C0-16TB
Weight	5.3 oz (151g)



**WARNING:** When using an Ethernet Analog PLC unit, you must use CLICK programming software version V2.20 or later.

**NOTE:** Please refer to the Analog I/O Configuration section in Chapter 3 for information on using the analog I/O.



**NOTE:** There are no ZIPLink pre-wired PLC connection cables and modules for the Ethernet Analog PLCs (cannot mix discrete I/O and analog I/O signals in a ZIPLink cable).

## C0-12DRE-1-D (continued)

### X1 - X4 (High-Speed)

Discrete I/O Specifications - Inputs	
Inputs per Module	4
Operating Voltage Range	24VDC
Input Voltage Range	21.6–26.4 VDC
Input Current	Typ 6.5 mA @ 24VDC
Max. Input Current	7mA @ 26.4 VDC
Input Impedance	3.9 kΩ @ 24VDC
Input Frequency (Max)	X1-X4: 100kHz
ON Voltage Level	>19VDC
OFF Voltage Level	< 2VDC
Minimum ON Current	4.5 mA
Maximum OFF Current	0.5 mA
OFF to ON Response	Typ 3μs Max 5μs
ON to OFF Response	Typ 1μs Max 3μs
Status Indicators	Logic Side (4 points, green LED)
Commons	1 (4 points/common)

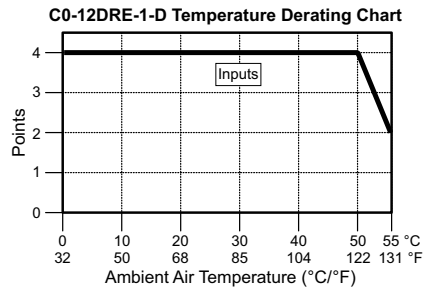
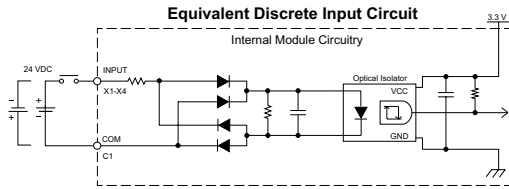

### Y1 - Y4

Discrete I/O Specifications - Outputs	
Outputs per Module	4
Operating Voltage Range	6–27 VDC, 6–240 VAC
Output Type	Relay, form A (SPST)
AC Frequency	47–63 Hz
Maximum Current	1A/point (resistive)
Minimum Load Current	5mA @ 5VDC
Maximum Inrush Current	3A for 10ms
OFF to ON Response	< 15ms
ON to OFF Response	< 15ms
Status Indicators	Logic Side (4 points, red LED)
Commons	1 (4 points/common)

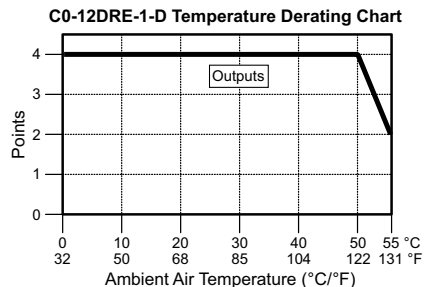
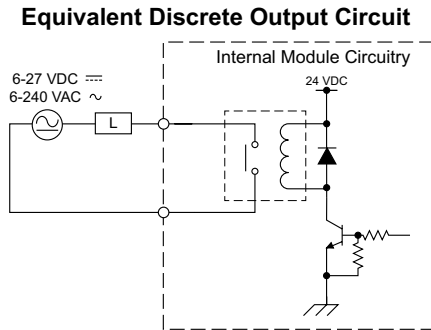

Typical Relay Life (Operations) at Room Temperature	
Voltage & Load Type	Relay Life
30VDC, 1A Resistive	300,000 cycles
30VDC, 1A Solenoid	50,000 cycles
120VAC, 1A Resistive	500,000 cycles
120VAC, 1A Solenoid	200,000 cycles
ON to OFF = 1 cycle	

C0-12DRE-1-D (continued)

AD1I - AD4I

Analog Specifications - Current Input	
Inputs per Module	4 (Current)
Input Range	0–20 mA (Sink)
Resolution	12-bit
Conversion Time	50ms
Input Impedance	125Ω
Input Stability	±2 LSB maximum
Full-Scale Calibration Error	±2% maximum
Offset Calibration Error	±0.1 mA maximum
Accuracy vs. Temperature Error	±100ppm / °C maximum

Analog Current Input Circuit

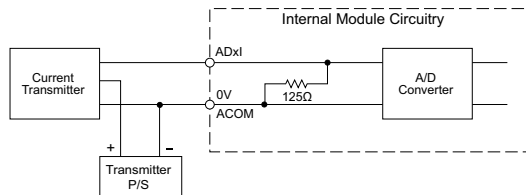

DA1I - DA2I

Analog Specifications - Current Output	
Outputs per Module	2 (Current)
Output Range	4–20 mA (Source)
Resolution	12-bit
Conversion Time	2.5 ms
Load Impedance	250Ω Typ (200Ω to 800Ω)
Loop Supply Voltage	24VDC Typ (21.6–26.4)
Full-Scale Calibration Error	±2% maximum
Offset Calibration Error	±25mA maximum
Accuracy vs. Temperature Error	±120ppm / °C maximum
External DC Power Required	21.6–26.4 VDC

Analog Current Output Circuit

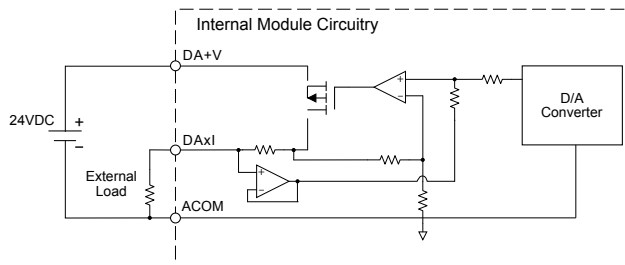

**C0-12ARE-1-D – 4 AC Input/4 Relay Output;**

**4 Analog Current Input**

**2 Analog Current Output Micro PLC**

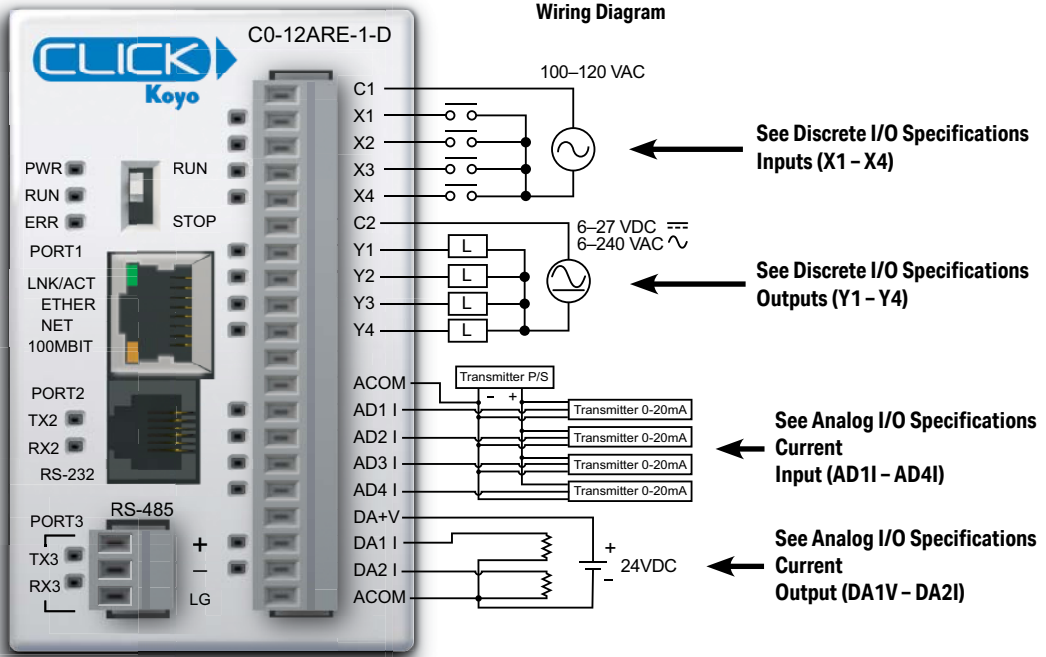

General Specifications	
Current Consumption at 24VDC	160mA
Terminal Block Replacement Part No.	C0-16TB
Weight	5.4 oz (154g)



**WARNING:** When using an Ethernet Analog PLC unit, you must use CLICK programming software version V2.20 or later.



**NOTE:** Please refer to the Analog I/O Configuration section in Chapter 3 for information on using the analog I/O.

**NOTE:** There are no ZIPLink pre-wired PLC connection cables and modules for the Ethernet Analog PLCs (cannot mix discrete I/O and analog I/O signals in a ZIPLink cable).

C0-12ARE-1-D (continued)

X1 - X4

Discrete I/O Specifications - Inputs	
Inputs per Module	4
Operating Voltage Range	100-120 VAC
AC Frequency	47-63 Hz
Input Current	Typ 8.5 mA @ 100VAC at 50Hz Typ 10mA @ 100VAC at 60Hz
Maximum Input Current	16mA @ 144VAC
Input Impedance	15kΩ @ 50Hz 12kΩ @ 60Hz
ON Voltage Level	> 60VAC
OFF Voltage Level	< 20VAC
Minimum ON Current	5mA
Maximum OFF Current	2mA
OFF to ON Response	< 40ms
ON to OFF Response	< 40ms
Status Indicators	Logic Side (4 points, green LED)
Commons	1 (4 points/common)

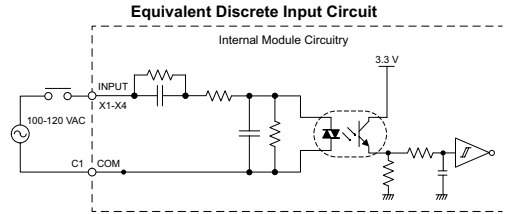

C0-12ARE-1-D Temperature Derating Chart

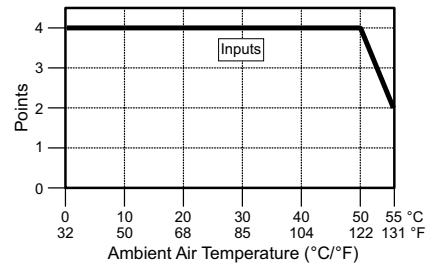

Y1 - Y4

Discrete I/O Specifications - Outputs	
Outputs per Module	4
Operating Voltage Range	6-27 VDC, 6-240 VAC
Output Type	Relay, form A (SPST)
AC Frequency	47-63 Hz
Maximum Current	1A/point (resistive)
Minimum Load Current	5mA @ 5VDC
Maximum Inrush Current	3A for 10ms
OFF to ON Response	< 15ms
ON to OFF Response	< 15ms
Status Indicators	Logic Side (4 points, red LED)
Commons per Module	1 (4 points/common)

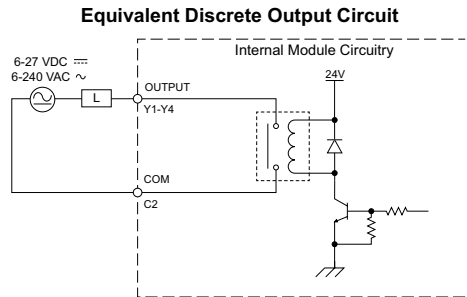

C0-12ARE-1-D Temperature Derating Chart

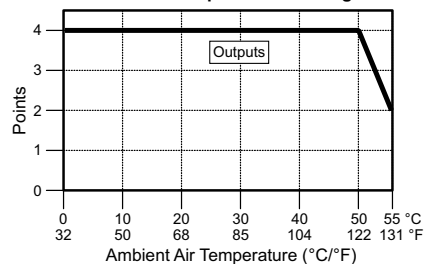

Typical Relay Life (Operations) at Room Temperature

Voltage & Load Type	Relay Life
30VDC, 1A Resistive	300,000 cycles
30VDC, 1A Solenoid	50,000 cycles
120VAC, 1A Resistive	500,000 cycles
120VAC, 1A Solenoid	200,000 cycles

ON to OFF = 1 cycle

C0-12ARE-1-D (continued)

AD1I – AD4I

Analog Specifications - Current Input	
Inputs per Module	4 (current)
Input Range	0–20 mA (sink)
Resolution	12-bit
Conversion Time	50ms
Input Impedance	125Ω
Input Stability	±2 LSB maximum
Full-Scale Calibration Error	±2% maximum
Offset Calibration Error	±0.1 mA maximum
Accuracy vs. Temperature Error	±100ppm / °C maximum

Analog Current Input Circuit

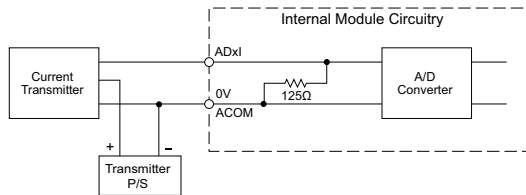

DA1I – DA2I

Analog Specifications - Current Output	
Outputs per Module	2 (current)
Output Range	4–20 mA (source)
Resolution	12-bit
Conversion Time	2.5 ms
Load Impedance	250Ω Typ (200Ω to 800Ω)
Loop Supply Voltage	DC 24V Typ (21.6–26.4 V)
Full-Scale Calibration Error	±2% maximum
Offset Calibration Error	±25mA maximum
Accuracy vs. Temperature Error	±120ppm / °C maximum
External DC Power Supply Required	21.6–26.4 VDC

Analog Current Output Circuit

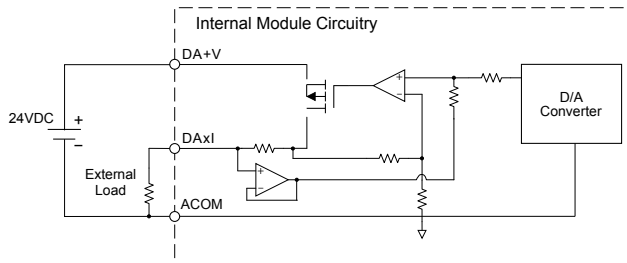

**C0-12DD1E-2-D – 4 DC Input (Sink/Source)/4 Sinking DC Output;  
4 Analog Voltage Input  
2 Analog Voltage Output Micro PLC**

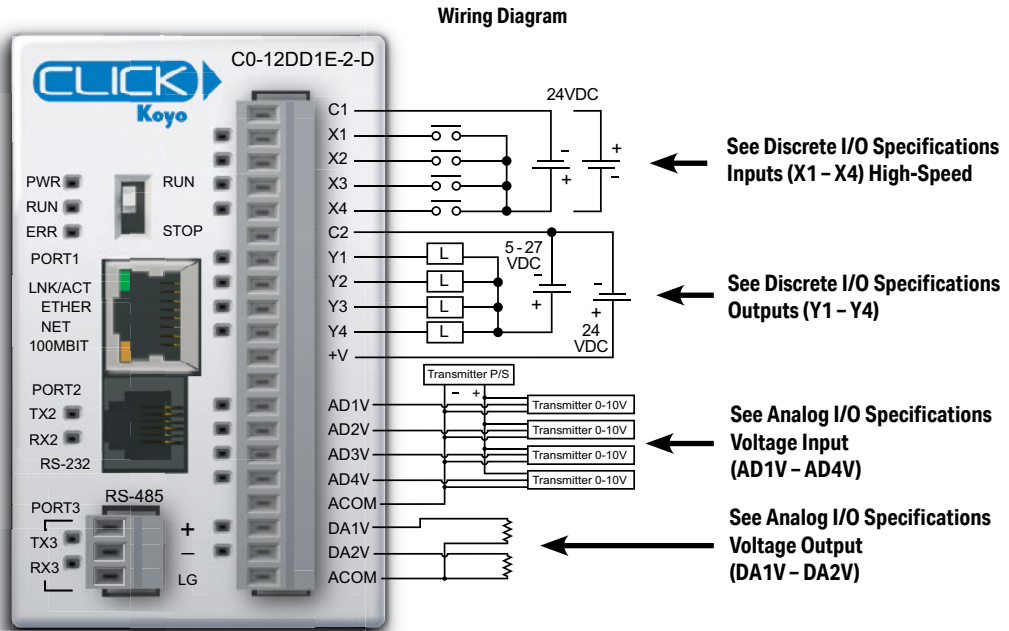

<b>General Specifications</b>	
<b>Current Consumption at 24VDC</b>	140mA
<b>Terminal Block Replacement Part No.</b>	C0-16TB
<b>Weight</b>	5.08 oz (144g)



**WARNING:** When using an Ethernet Analog PLC unit, you must use CLICK programming software version V2.20 or later.

**NOTE:** Please refer to the Analog I/O Configuration section in Chapter 3 for information on using the analog I/O.



**NOTE:** There are no ZIPLink pre-wired PLC connection cables and modules for the Ethernet Analog PLCs (cannot mix discrete I/O and analog I/O signals in a ZIPLink cable).

## C0-12DD1E-2-D (continued)

### X1 - X4 (High-Speed)

Discrete I/O Specifications - Inputs	
Inputs per Module	4 (Source/Sink)
Operating Voltage Range	24VDC
Input Voltage Range	21.6–26.4 VDC
Input Current	Typ 6.5 mA @ 24VDC
Max. Input Current	7mA @ 26.4 VDC
Input Impedance	3.9 kΩ @ 24VDC
ON Voltage Level	>19VDC
OFF Voltage Level	< 2VDC
Minimum ON Current	4.5 mA
Maximum OFF Current	0.5 mA
OFF to ON Response	Typ 3μs Max 5μs
ON to OFF Response	Typ 1μs Max 3μs
Status Indicators	Logic Side (4 points, green LED)
Commons	1 (4 points/common)

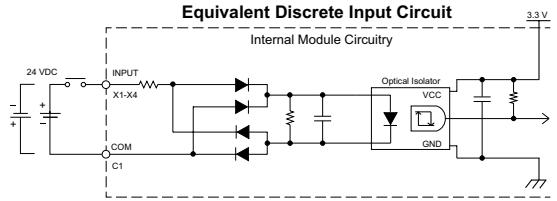

C0-12DD1E-2-D Temperature Derating Chart

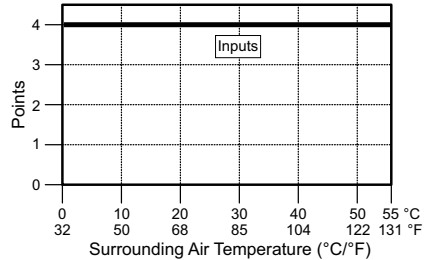

### Y1 - Y4

Discrete I/O Specifications - Outputs	
Outputs per Module	4 (Sink)
Operating Voltage Range	5–27 VDC
Maximum Output Current	0.1 A/point; 0.4 A/common
Minimum Output Current	0.2 mA
Maximum Leakage Current	0.1 mA @ 30.0 VDC
On Voltage Drop	0.5 VDC @ 0.1 A
Maximum Inrush Current	150 mA for 10ms
OFF to ON Response	5μs
ON to OFF Response	5μs
Status Indicators	Logic Side (4 points, red LED)
Commons	1 (4 points/common)
External DC Power Required	20–28 VDC Maximum @ 60mA (All points on)

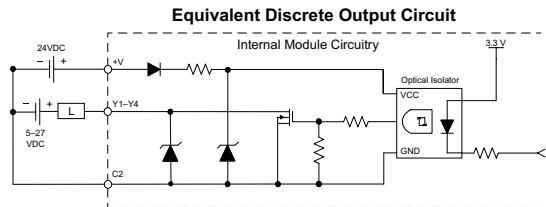

C0-12DD1E-2-D Temperature Derating Chart

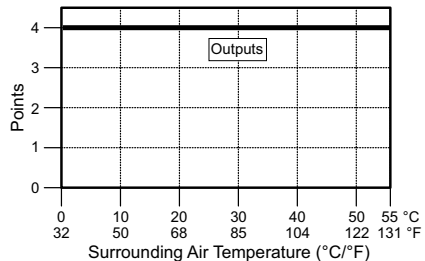

## C0-12DD1E-2-D (continued)

## AD1V - AD4V

Analog Specifications - Voltage Input	
Inputs per Module	4 (voltage)
Input Range	0-10 VDC
Resolution	12-bit
Conversion Time	50ms
Input Impedance	40k $\Omega$
Input Stability	$\pm 2$ LSB maximum
Full-Scale Calibration Error	$\pm 2\%$ maximum
Offset Calibration Error	$\pm 25$ mV maximum
Accuracy vs. Temperature Error	$\pm 100$ ppm / $^{\circ}$ C maximum

Analog Voltage Input Circuit

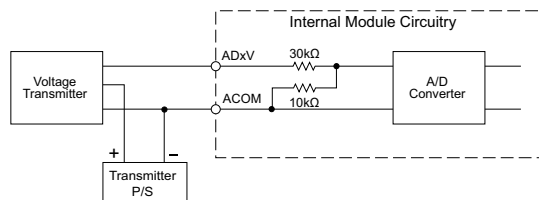

## DA1V - DA2V

Analog Specifications - Voltage Output	
Outputs per Module	2 (voltage)
Output Range	0-10 VDC
Resolution	12-bit
Conversion Time	1ms
Load Impedance	4k $\Omega$ minimum (output current 2.5 mA maximum)
Full-Scale Calibration Error	$\pm 2\%$ maximum
Offset Calibration Error	$\pm 25$ mV maximum
Accuracy vs. Temperature Error	$\pm 100$ ppm / $^{\circ}$ C maximum

Analog Voltage Output Circuit

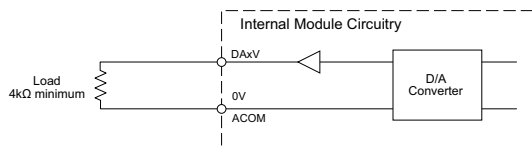

**C0-12DD2E-2-D – 4 DC Input (Sink/Source)/4 Sourcing DC Output;  
4 Analog Voltage Input  
2 Analog Voltage Output Micro PLC**

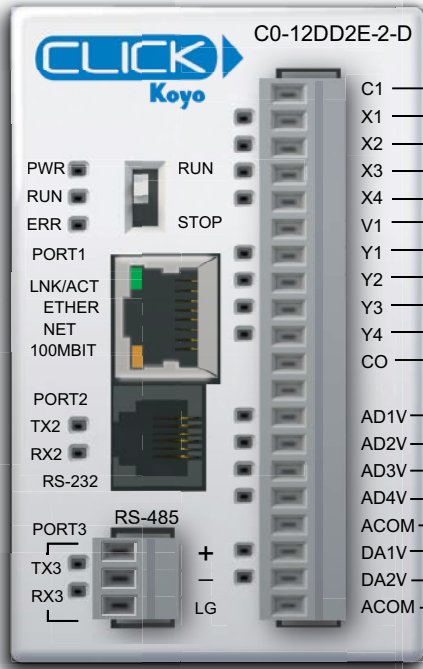

Wiring Diagram

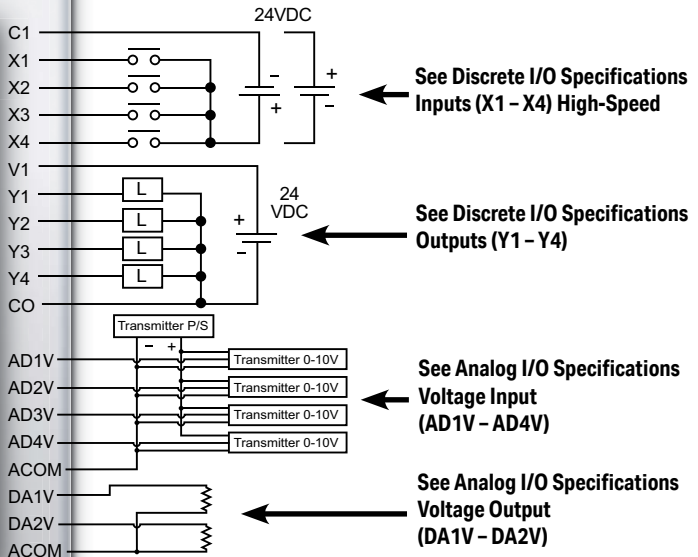

General Specifications	
Current Consumption at 24VDC	140mA
Terminal Block Replacement Part No.	C0-16TB
Weight	5.08 oz (144g)



**WARNING:** When using an Ethernet Analog PLC unit, you must use CLICK programming software version V2.20 or later.



**NOTE:** Please refer to the Analog I/O Configuration section in Chapter 3 for information on using the analog I/O.

**NOTE:** There are no ZIPLink pre-wired PLC connection cables and modules for the Ethernet Analog PLCs (cannot mix discrete I/O and analog I/O signals in a ZIPLink cable).

C0-12DD2E-2-D (continued)

X1 - X4 (High-Speed)

Discrete I/O Specifications - Inputs	
Inputs per Module	4 (Source/Sink)
Operating Voltage Range	24VDC
Input Voltage Range	21.6–26.4 VDC
Input Current	Typ 6.5 mA @ 24VDC
Max. Input Current	7mA @ 26.4 VDC
Input Impedance	3.9 kΩ @ 24VDC
ON Voltage Level	>19VDC
OFF Voltage Level	< 2VDC
Minimum ON Current	4.5 mA
Maximum OFF Current	0.5 mA
OFF to ON Response	Typ 3μs Max 5μs
ON to OFF Response	Typ 1μs Max 3μs
Status Indicators	Logic Side (4 points, green LED)
Commons	1 (4 points/common)

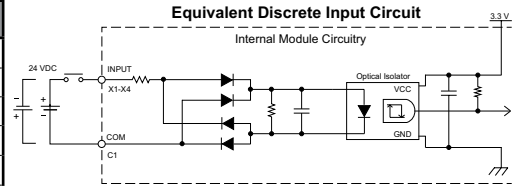

C0-12DD2E-2-D Temperature Derating Chart

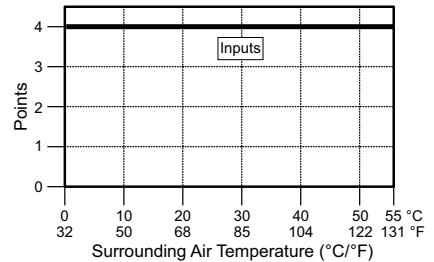

Y1 - Y4

Discrete I/O Specifications - Outputs	
Outputs per Module	4 (Source)
Operating Voltage Range	24VDC
Output Voltage Range	19.2–30 VDC
Maximum Output Current	0.1 A/point, 0.4 A/common
Minimum Output Current	0.2 mA
Maximum Leakage Current	0.1mA @ 30VDC
On Voltage Drop	0.5 VDC@ 0.1 mA
Maximum Inrush Current	150mA for 10ms
OFF to ON Response	< 5μs
ON to OFF Response	< 5μs
Status Indicators	Logic Side (4 points, red LED)
Commons	1 (4 points/common)

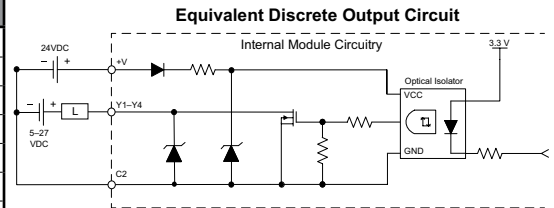

C0-12DD2E-2-D Temperature Derating Chart

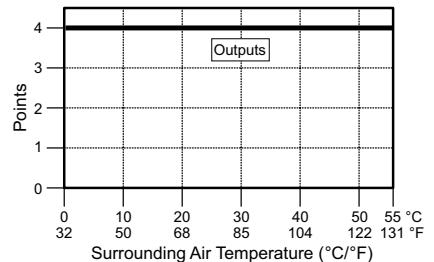

C0-12DD2E-2-D (continued)

AD1V - AD4V

Analog Specifications - Voltage Input	
Inputs per Module	4 (voltage)
Input Range	0-10 VDC
Resolution	12-bit
Conversion Time	50ms
Input Impedance	40kΩ
Input Stability	±2 LSB maximum
Full-Scale Calibration Error	±2% maximum
Offset Calibration Error	±25mV maximum
Accuracy vs. Temperature Error	±100ppm / °C maximum

Analog Voltage Input Circuit

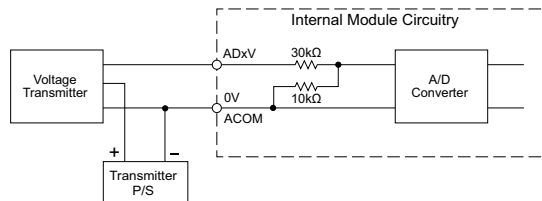

DA1V - DA2V

Analog Specifications - Voltage Output	
Outputs per Module	2 (voltage)
Output Range	0-10 VDC
Resolution	12-bit
Conversion Time	1ms
Load Impedance	4kΩ minimum (output current 2.5 mA maximum)
Full-Scale Calibration Error	±2% maximum
Offset Calibration Error	±25mV maximum
Accuracy vs. Temperature Error	±100ppm / °C maximum

Analog Voltage Output Circuit

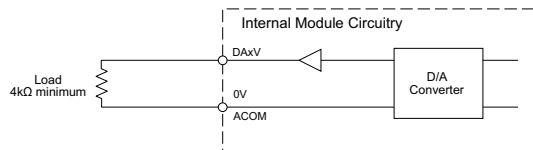

**C0-12DRE-2-D – 4 DC Input (Sink/Source)/4 Relay Output;**

**4 Analog Voltage Input**

**2 Analog Voltage Output Micro PLC**

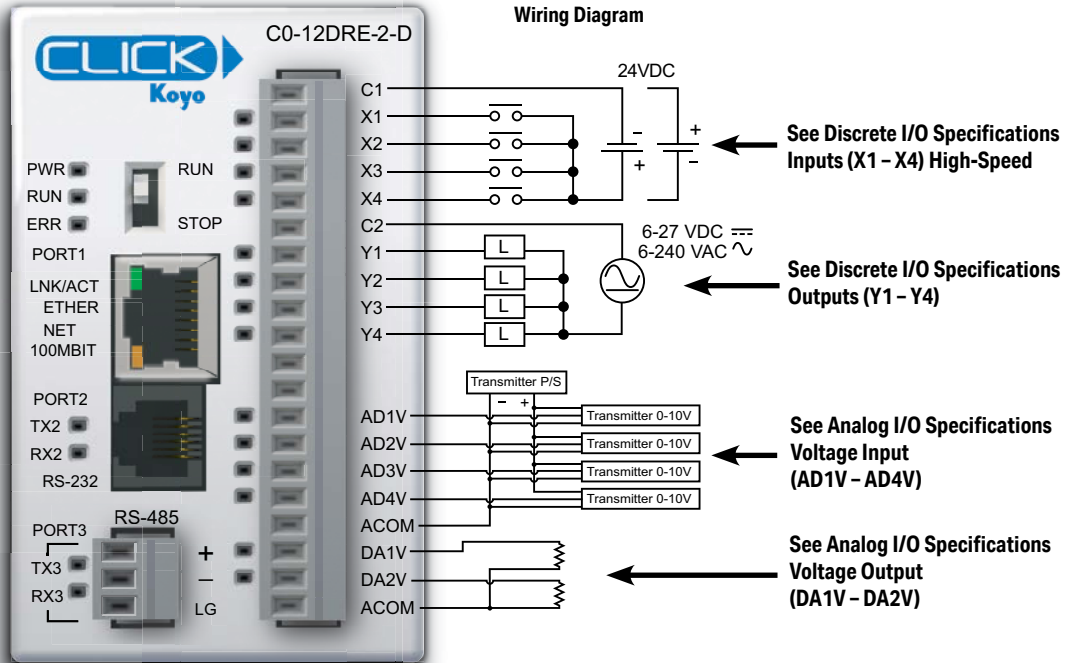

General Specifications	
Current Consumption at 24VDC	160mA
Terminal Block Replacement Part No.	C0-16TB
Weight	5.4 oz (154g)



**WARNING:** When using an Ethernet Analog PLC unit, you must use CLICK programming software version V2.20 or later.

**NOTE:** Please refer to the Analog I/O Configuration section in Chapter 3 for information on using the analog I/O.



**NOTE:** There are no ZIPLink pre-wired PLC connection cables and modules for the Ethernet Analog PLCs (cannot mix discrete I/O and analog I/O signals in a ZIPLink cable).

## C0-12DRE-2-D (continued)

### X1 - X4 (High-Speed)

Discrete I/O Specifications - Inputs	
Inputs per Module	4
Operating Voltage Range	24VDC
Input Voltage Range	21.6–26.4 VDC
Input Current	Typ 6.5 mA @ 24VDC
Max. Input Current	7mA @ 26.4 VDC
Input Impedance	3.9 kΩ @ 24VDC
ON Voltage Level	>19VDC
OFF Voltage Level	< 2VDC
Minimum ON Current	4.5 mA
Maximum OFF Current	0.5 mA
OFF to ON Response	Typ 3μs Max 5μs
ON to OFF Response	Typ 1μs Max 3μs
Status Indicators	Logic side (4 points, green LED)
Commons	1 (4 points/common)

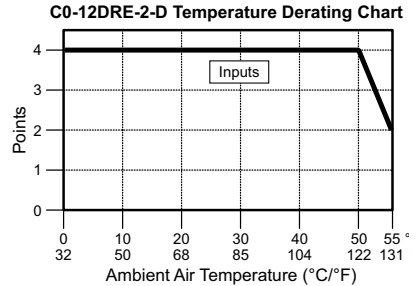
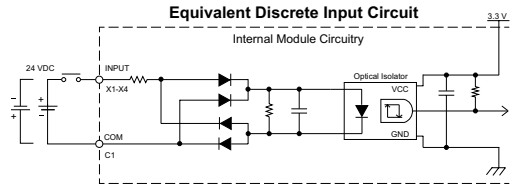

### Y1 - Y4

Discrete I/O Specifications - Outputs	
Outputs per Module	4
Operating Voltage Range	6–27 VDC, 6–240 VAC
Output Type	Relay, form A (SPST)
AC Frequency	47–63 Hz
Maximum Current	1A/point (resistive)
Minimum Load Current	5mA @ 5VDC
Maximum Inrush Current	3A for 10ms
OFF to ON Response	< 15ms
ON to OFF Response	< 15ms
Status Indicators	Logic Side (4 points, red LED)
Commons per Module	1 (4 points/common)

### Equivalent Discrete Output Circuit

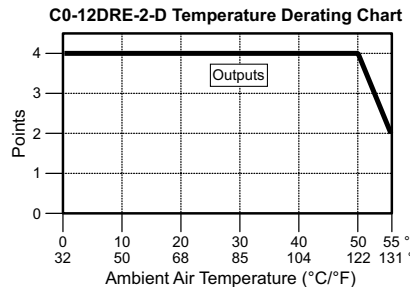
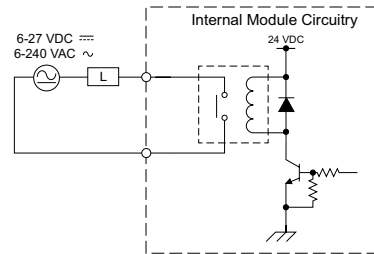

### Typical Relay Life (Operations) at Room Temperature

Voltage & Load Type	Relay Life
30VDC, 1A Resistive	300,000 cycles
30VDC, 1A Solenoid	50,000 cycles
120VAC, 1A Resistive	500,000 cycles
120VAC, 1A Solenoid	200,000 cycles

ON to OFF = 1 cycle

## C0-12DRE-2-D (continued)

## AD1V - AD4V

Analog Specifications - Voltage Input	
Inputs per Module	4 (voltage)
Input Range	0–10 VDC
Resolution	12-bit
Conversion Time	50ms
Input Impedance	40k $\Omega$
Input Stability	$\pm 2$ LSB maximum
Full-Scale Calibration Error	$\pm 2\%$ maximum
Offset Calibration Error	$\pm 25$ mV maximum
Accuracy vs. Temperature Error	$\pm 100$ ppm / $^{\circ}$ C maximum

Analog Voltage Input Circuit

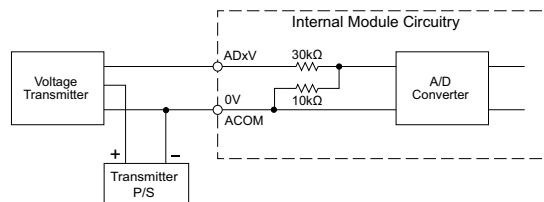

## DA1V - DA2V

Analog Specifications - Voltage Output	
Outputs per Module	2 (voltage)
Output Range	0–10 VDC
Resolution	12-bit
Conversion Time	1ms
Load Impedance	4k $\Omega$ minimum (output current 2.5 mA maximum)
Full-Scale Calibration Error	$\pm 2\%$ maximum
Offset Calibration Error	$\pm 25$ mV maximum
Accuracy vs. Temperature Error	$\pm 100$ ppm / $^{\circ}$ C maximum

Analog Voltage Output Circuit

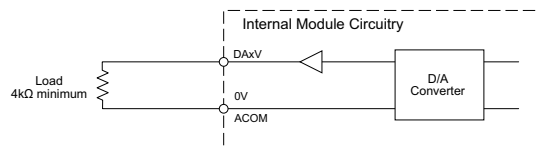

**C0-12ARE-2-D – 4 AC Input (Sink/Source) /4 Relay Output;  
4 Analog Voltage Input  
2 Analog Voltage Output Micro PLC**

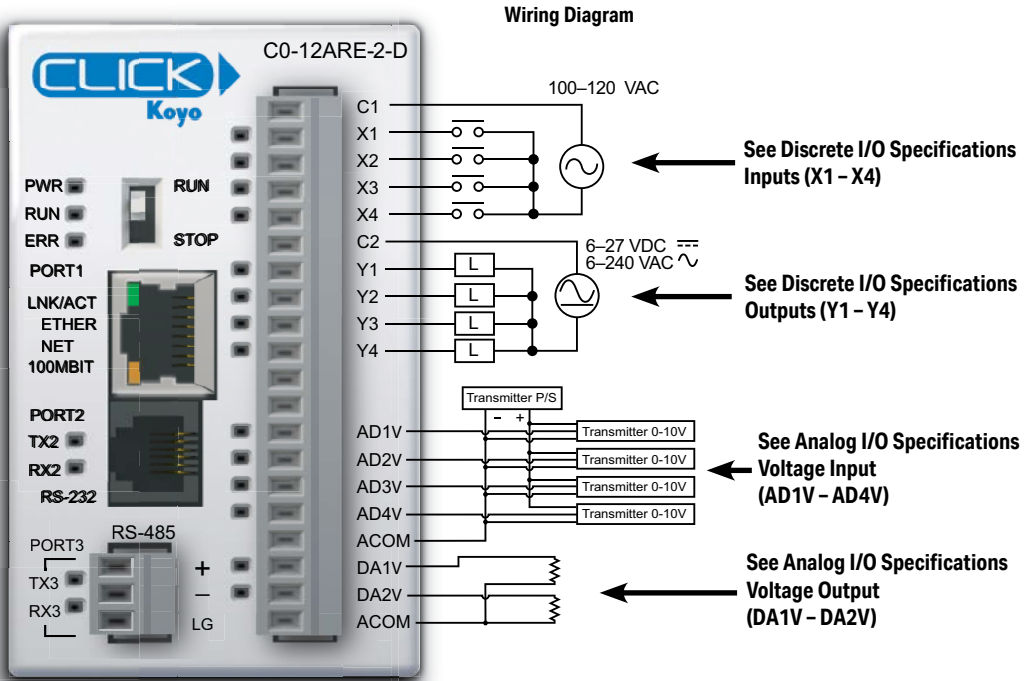

General Specifications	
<b>Current Consumption at 24VDC</b>	140mA
<b>Terminal Block Replacement Part No.</b>	C0-16TB
<b>Weight</b>	5.4 oz (155g)



**WARNING:** When using an Ethernet Analog PLC unit, you must use CLICK programming software version V2.20 or later.

**NOTE:** Please refer to the Analog I/O Configuration section in Chapter 3 for information on using the analog I/O.



**NOTE:** There are no ZIPLink pre-wired PLC connection cables and modules for the Ethernet Analog PLCs (cannot mix discrete I/O and analog I/O signals in a ZIPLink cable).

C0-12ARE-2-D (continued)

X1 - X4

Discrete I/O Specifications - Inputs	
Inputs per Module	4
Operating Voltage Range	100-120 VAC
AC Frequency	47-63 Hz
Input Current	Typ 8.5 mA @ 100VAC at 50Hz Typ 10mA @ 100VAC at 60Hz
Maximum Input Current	16mA @ 144VAC
Input Impedance	15kΩ @ 50Hz 12kΩ @ 60Hz
ON Voltage Level	> 60VAC
OFF Voltage Level	< 20VAC
Minimum ON Current	5mA
Maximum OFF Current	2mA
OFF to ON Response	< 40ms
ON to OFF Response	< 40ms
Status Indicators	Logic Side (4 points, green LED)
Commons	1 (4 points/common)

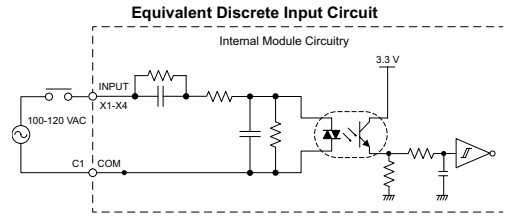

C0-12ARE-2-D Temperature Derating Chart

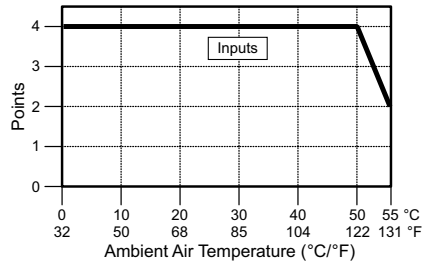

Y1 - Y4

Discrete I/O Specifications - Outputs	
Outputs per Module	4
Operating Voltage Range	6-27 VDC, 6-240 VAC
Output Type	Relay, form A (SPST)
AC Frequency	47-63 Hz
Maximum Current	1A/point (resistive)
Minimum Load Current	5mA @ 5VDC
Maximum Inrush Current	3A for 10ms
OFF to ON Response	< 15ms
ON to OFF Response	< 15ms
Status Indicators	Logic Side (4 points, red LED)
Commons per Module	1 (4 points/common)

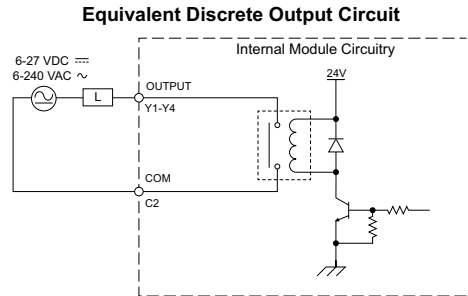

C0-12ARE-2-D Temperature Derating Chart

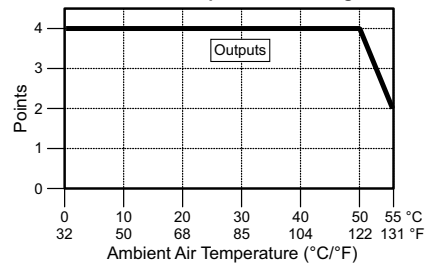

Typical Relay Life (Operations) at Room Temperature

Voltage & Load Type	Relay Life
30VDC, 1A Resistive	300,000 cycles
30VDC, 1A Solenoid	50,000 cycles
120VAC, 1A Resistive	500,000 cycles
120VAC, 1A Solenoid	200,000 cycles

ON to OFF = 1 cycle

C0-12ARE-2-D (continued)

AD1V - AD4V

Analog Specifications - Voltage Input	
Inputs per Module	4 (voltage)
Input Range	0-10 VDC
Resolution	12-bit
Conversion Time	50ms
Input Impedance	40kΩ
Input Stability	±2 LSB maximum
Full-Scale Calibration Error	±2% maximum
Offset Calibration Error	±25mV maximum
Accuracy vs. Temperature Error	±100ppm / °C maximum

Analog Voltage Input Circuit

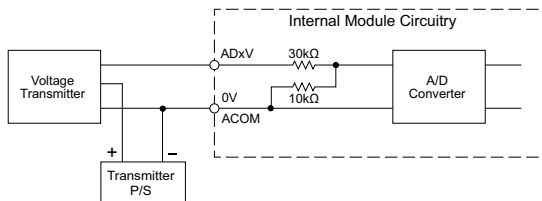

DA1V - DA2V

Analog Specifications - Voltage Output	
Outputs per Module	2 (voltage)
Output Range	0-10 VDC
Resolution	12-bit
Conversion Time	1ms
Load Impedance	4kΩ minimum (output current 2.5 mA maximum)
Full-Scale Calibration Error	±2% maximum
Offset Calibration Error	±25mV maximum
Accuracy vs. Temperature Error	±100ppm / °C maximum

Analog Voltage Output Circuit

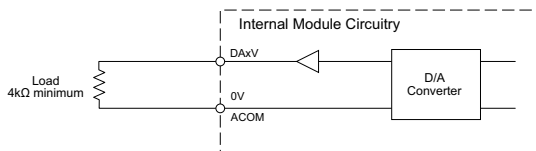

# I/O Module Specifications

## I/O Terminal Block Specifications for CPUs and I/O Modules



11-Pin Terminal Block,  
C0-8TB

11-pin Terminal Block Specifications	
Connector Type	Pluggable Terminal Block
Number of Pins	11 pt
Pitch	3.50 mm
Wire Range	28–16 AWG
Wire Strip Length	7mm
Screw Size	M2.0
Screw Torque	2.0 to 2.2 lb-inch
AutomationDirect Part Number	C0-8TB

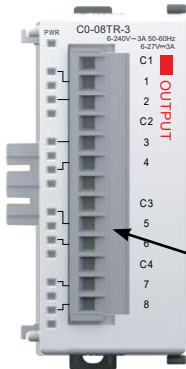

13-Pin Terminal Block,  
C0-8TB-1

13-pin Terminal Block Specifications	
Connector Type	Pluggable Terminal Block
Number of Pins	13 pt
Pitch	5.08 mm
Wire Range	12–20 AWG
Wire Strip Length	7.0–8.0 mm
Screw Size	M2.5
Screw Torque	4.51 lb-inch
AutomationDirect Part Number	C0-8TB-1

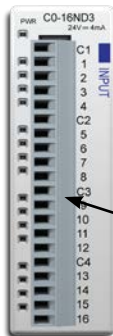

20-Pin Terminal Block,  
C0-16TB

20-pin Terminal Block Specifications	
Connector Type	Pluggable Terminal Block
Number of Pins	20 pt
Pitch	3.50 mm
Wire Range	28–16 AWG
Wire Strip Length	7mm
Screw Size	M2.0
Screw Torque	2.0 to 2.2 lb-inch
AutomationDirect Part Number	C0-16TB

### LED Indicators

All CLICK I/O modules, except analog modules, have an LED Power Indicator (PWR). When this LED is on, the I/O module is receiving 24VDC through the backplane connector correctly. The input modules have green LEDs and the output modules have red LEDs respectively as the status indicator. When the LED is on, the I/O point is on.

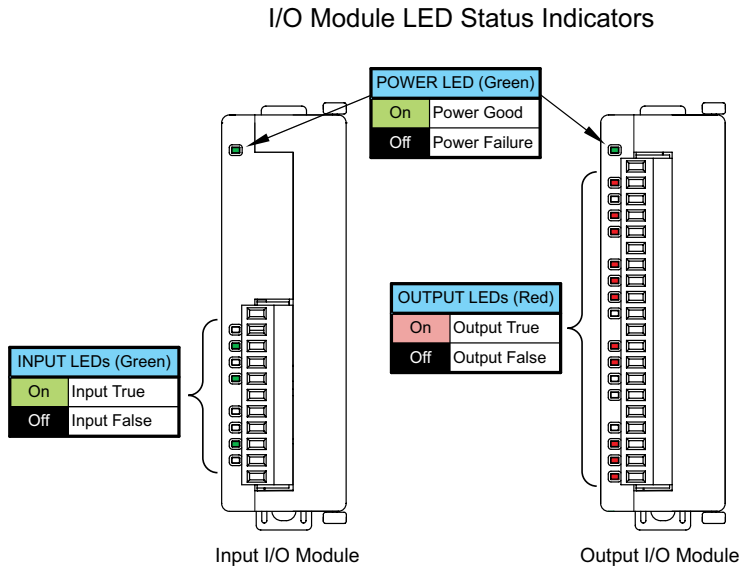

## C0-08SIM – 8-Point Toggle Switch Input Module

8-point toggle switch input module provides for simple simulation of system discrete inputs.



Input Specifications	
<b>Inputs per Module</b>	8 Toggle Switches
<b>OFF to ON Response</b>	Max 140ms, Typ 90ms
<b>ON to OFF Response</b>	Max 110ms, Typ 60ms
<b>Status Indicators</b>	Logic Side (8 points, green LED) Power Indicator (green LED)
<b>Bus Power Required</b>	Max. 50mA (All points ON)
<b>Weight</b>	2.9 oz (84g)



### CAUTION

*The C0-08SIM unit toggle switch can get hot when mounted in hot environment. Wear heat-resistant gloves before use, as it may cause burns.*

### C0-04POT – 4-Point Potentiometer Input Module

4-point potentiometer input module with 12-bit resolution provides for simple simulation of system analog inputs.



Input Specifications	
Inputs per Module	4 Potentiometers
Resolution	12-bit
Total Rotation Angle	280° ±10°
Conversion Time	25ms
Input Stability	±2LSB maximum
Full-Scale Calibration Error	±2% maximum
Offset Calibration Error	±13LSB maximum
Accuracy vs Temperature Error	±100ppm/°C maximum
Instantaneous Deviation During Noise Test	±20% of full scale maximum
Status Indicators	Logic Side (8 points, green LED) Power Indicator (green LED)
Bus Power Required	30mA maximum
Weight	2.9 oz [84g]

### C0-08ND3 – 8-Point Sink/Source DC Input Module

8-point 12–24 VDC current sinking or sourcing input module, 2 commons, isolated, removable terminal block included.

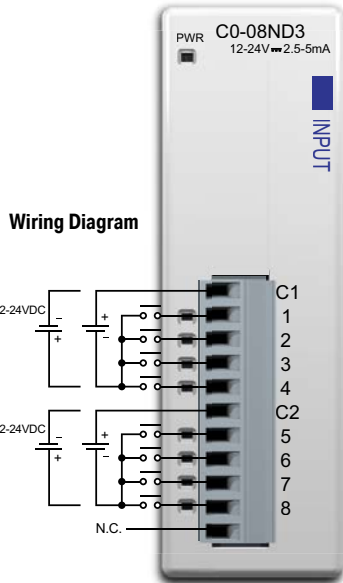

N.C. = Not Connected

Input Specifications	
<b>Inputs per Module</b>	8 (Sink/Source)
<b>Operating Voltage Range</b>	12–24 VDC
<b>Input Voltage Range</b>	10.8–26.4 VDC
<b>Input Current</b>	Typ 5mA @ 24VDC
<b>Maximum Input Current</b>	7mA @ 26.4 VDC
<b>Input Impedance</b>	4.7 kΩ @ 24VDC
<b>ON Voltage Level</b>	> 8.0 VDC
<b>OFF Voltage Level</b>	< 3.0 VDC
<b>Minimum ON Current</b>	1.4 mA
<b>Maximum OFF Current</b>	0.5 mA
<b>OFF to ON Response</b>	Max 3.5 ms, Typ 2ms
<b>ON to OFF Response</b>	Max 4 ms, Typ 2.5 ms
<b>Status Indicators</b>	Logic Side (8 points, green LED) Power Indicator (green LED)
<b>Commons</b>	2 (4 points/common) Isolated
<b>Bus Power Required (24VDC)</b>	Max. 30mA (All Inputs On)
<b>Terminal Block Replacement</b>	AutomationDirect p/n C0-8TB
<b>Weight</b>	2.8 oz (80g)

#### Equivalent Input Circuit

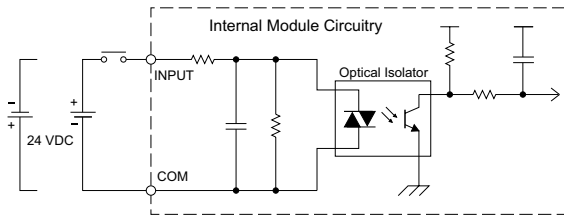

#### Input Module Temperature Derating Chart

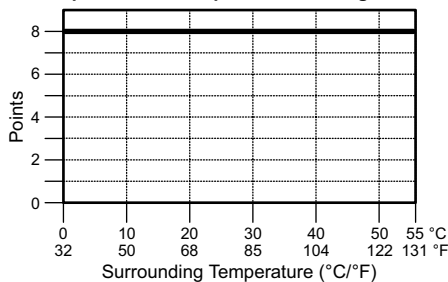

#### ZIPLink Pre-Wired PLC Connection Cables and Modules for CLICK PLC



- 11-pin connector cable
- ZL-C0-CBL11 (0.5 m length)
- ZL-C0-CBL11-1 (1.0 m length)
- ZL-C0-CBL11-2 (2.0 m length)



- ZL-RTB20
- 20-pin feed-through connector module

## C0-08ND3-1 – 8-Point Sink/Source DC Input Module

8-point 3.3–5 VDC current sinking or sourcing input module, 2 commons, isolated, removable terminal block included.

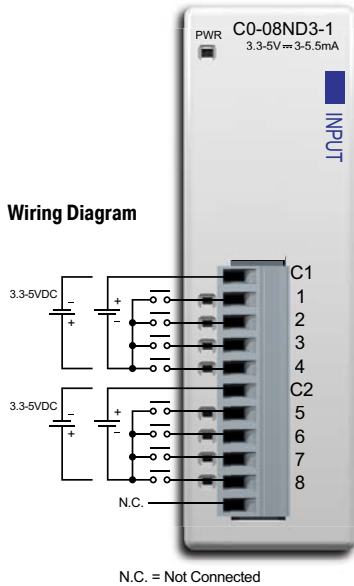

Input Specifications	
<b>Inputs per Module</b>	8 (Sink/Source)
<b>Operating Voltage Range</b>	3.3–5 VDC
<b>Input Voltage Range</b>	2.8–5.5 VDC
<b>Input Current</b>	Typ 5.5 mA @ 5 VDC
<b>Maximum Input Current</b>	7.5 mA @ 5.5 VDC
<b>Input Impedance</b>	680 Ω
<b>ON Voltage Level</b>	> 2.2 VDC
<b>OFF Voltage Level</b>	< 0.8 VDC
<b>Minimum ON Current</b>	1.4 mA
<b>Maximum OFF Current</b>	0.2 mA
<b>OFF to ON Response</b>	Max. 3ms Typ. 1.6 ms
<b>ON to OFF Response</b>	Max. 4ms Typ. 2.3 ms
<b>Status Indicators</b>	Logic Side (8 points, green LED) Power Indicator (green LED)
<b>Commons</b>	2 (4 points/common) Isolated
<b>Bus Power Required (24VDC)</b>	Max. 30mA (All Inputs On)
<b>Terminal Block Replacement</b>	AutomationDirect p/n C0-8TB
<b>Weight</b>	2.8 oz (80g)

### Equivalent Input Circuit

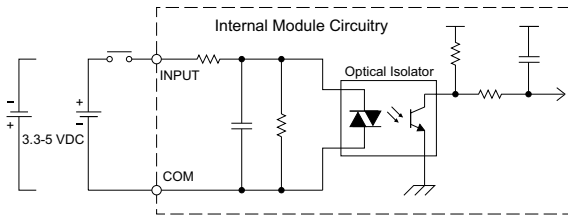

### Input Module Temperature Derating Chart

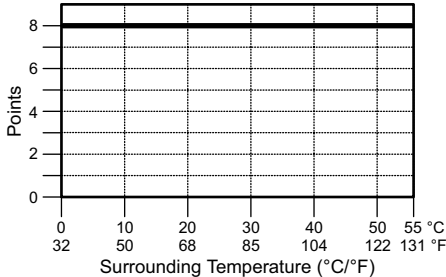

### ZIPLink Pre-Wired PLC Connection Cables and Modules for CLICK PLC



- 11-pin connector cable
- ZL-C0-CBL11 (0.5 m length)
- ZL-C0-CBL11-1 (1.0 m length)
- ZL-C0-CBL11-2 (2.0 m length)

### ZL-RTB20 20-pin feed-through connector module



### C0-16ND3 – 16-Point Sink/Source DC Input Module

16-point 24VDC current sinking or sourcing input module, 4 commons, isolated, removable terminal block included.

Wiring Diagram

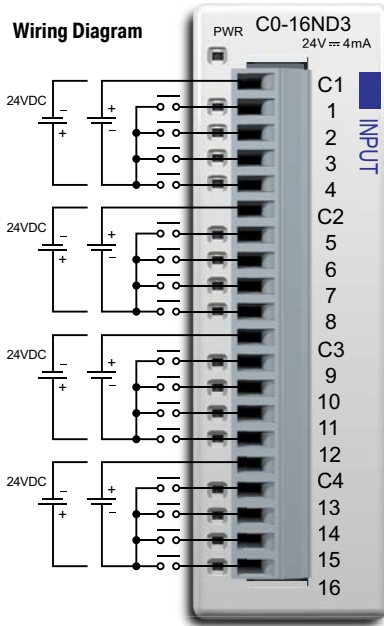

Input Specifications	
Inputs per Module	16 (Sink/Source)
Operating Voltage Range	24VDC
Input Voltage Range	21.6–26.4 VDC
Input Current	Typ 4.0 mA @ 24VDC
Maximum Input Current	5.0 mA @ 26.4 VDC
Input Impedance	6.8 kΩ @ 24VDC
ON Voltage Level	> 19VDC
OFF Voltage Level	< 7VDC
Minimum ON Current	3.5 mA
Maximum OFF Current	0.5 mA
OFF to ON Response	Max. 10ms Typ 2ms
ON to OFF Response	Max. 10ms Typ 3ms
Status Indicators	Logic Side (16 points, green LED) Power Indicator (green LED)
Commons	4 (4 points/common) Isolated
Bus Power Required (24VDC)	Max. 40 mA (All Inputs On)
Terminal Block Replacement	AutomationDirect p/n C0-16TB
Weight	3.2 oz (90g)

Equivalent Input Circuit

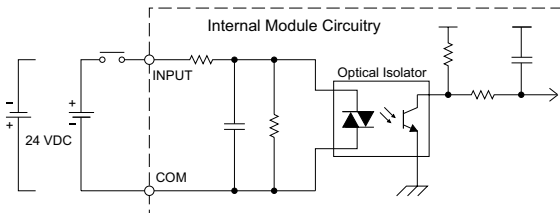

ZIPLink Pre-Wired PLC Connection Cables and Modules for CLICK PLC

- 20-pin connector cable
- ZL-C0-CBL20 (0.5 m length)
- ZL-C0-CBL20-1 (1.0 m length)
- ZL-C0-CBL20-2 (2.0 m length)

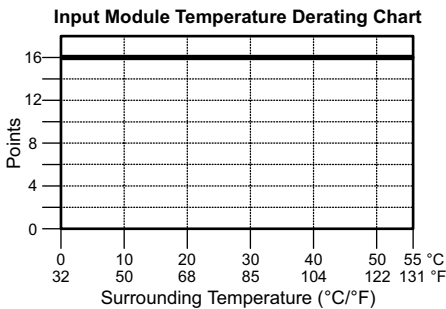

ZL-RTB20 20-pin feed-through connector module



ZL-LTB16-24-1 sensor input module

## C0-08NE3 – 8-Point Sink/Source AC/DC Input Module

8-point 24VAC / 24VDC current sinking or sourcing input module, 2 commons, 4 points per common, removable terminal block included.

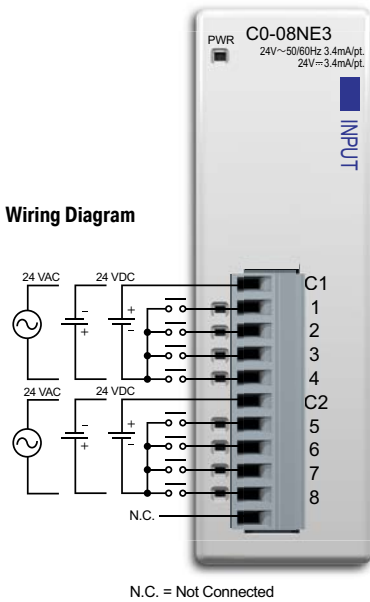

Input Specifications	
<b>Inputs per Module</b>	8 (Sink/Source)
<b>Operating Voltage Range</b>	24 VAC/VDC
<b>Input Voltage Range</b>	20.4-27.6 VAC/VDC
<b>Peak Voltage</b>	27.6 VAC/VDC
<b>AC Frequency</b>	47-63 Hz
<b>Input Current</b>	Typ 3.4 mA @ 24 VAC/VDC
<b>Maximum Input Current</b>	5.0 mA @ 27.6 VAC/VDC
<b>Input Impedance</b>	6.8 KΩ @ 24 VAC/VDC
<b>ON Voltage Level</b>	> 18.0 VAC/VDC
<b>OFF Voltage Level</b>	< 4.0 VAC/VDC
<b>Minimum ON Current</b>	2.5 mA
<b>Maximum OFF Current</b>	0.5 mA
<b>OFF to ON Response</b>	5-40 ms
<b>ON to OFF Response</b>	10-50 ms
<b>Status Indicators</b>	Logic Side (8 points, green LED) Power Indicator (green LED)
<b>Commons</b>	2 (4 points/common) Isolated
<b>Bus Power Required (24VDC)</b>	Max. 30mA (All Inputs On)
<b>Terminal Block Replacement</b>	AutomationDirect p/n C0-8TB
<b>Weight</b>	2.9 oz (82g)



**NOTE:** When using this module you must also use CLICK programming software version V1.20 or later.

### Equivalent Input Circuit

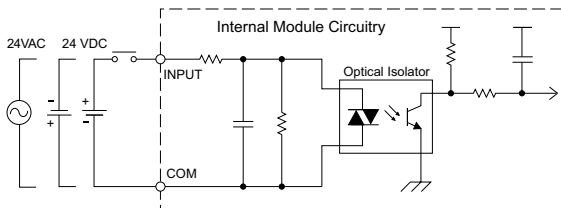

### Input Module Temperature Derating Chart

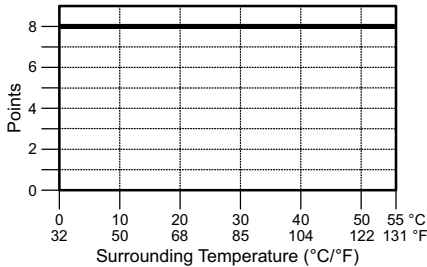

### ZIPLink Pre-Wired PLC Connection Cables and Modules for CLICK PLC

11-pin connector cable  
 ZL-C0-CBL11 (0.5 m length)  
 ZL-C0-CBL11-1 (1.0 m length)  
 ZL-C0-CBL11-2 (2.0 m length)



ZL-RTB20  
 20-pin feed-through connector module



### C0-16NE3 – 16-Point Sink/Source AC/DC Input Module

16-point 24VAC / 24VDC current sinking or sourcing input module, 4 commons, 4 points per common, removable terminal block included.

Wiring Diagram

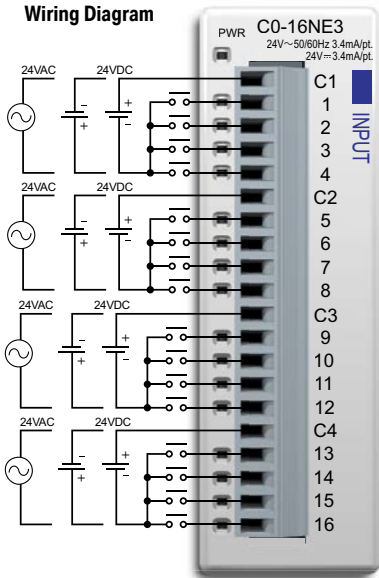

Input Specifications

<b>Inputs per Module</b>	16 (Sink/Source)
<b>Operating Voltage Range</b>	24 VAC/VDC
<b>Input Voltage Range</b>	20.4–27.6 VAC/VDC
<b>Peak Voltage</b>	27.6 VAC/VDC
<b>AC Frequency</b>	47–63 Hz
<b>Input Current</b>	Typ 3.4 mA @ 24 VAC/VDC
<b>Maximum Input Current</b>	5.0 mA @ 27.6 VAC/VDC
<b>Input Impedance</b>	6.8 kΩ @ 24 VAC/VDC
<b>ON Voltage Level</b>	> 18.0 VAC/VDC
<b>OFF Voltage Level</b>	< 4.0 VAC/VDC
<b>Minimum ON Current</b>	2.5 mA
<b>Maximum OFF Current</b>	0.5 mA
<b>OFF to ON Response</b>	5–40 ms
<b>ON to OFF Response</b>	10–50 ms
<b>Status Indicators</b>	Logic Side (16 points, green LED) Power Indicator (green LED)
<b>Commons</b>	4 (4 points/common) Isolated
<b>Bus Power Required (24VDC)</b>	Max. 40mA (All Inputs On)
<b>Terminal Block Replacement</b>	AutomationDirect p/n C0-16TB
<b>Weight</b>	3.2 oz (90g)



**NOTE:** When using this module you must also use CLICK programming software version V1.20 or later.

ZIPLink Pre-Wired PLC Connection Cables and Modules for CLICK PLC

Equivalent Input Circuit

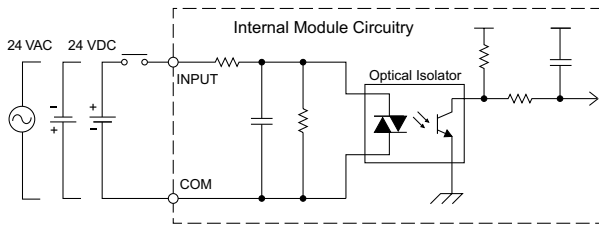

- 20-pin connector cable
- ZL-C0-CBL20 (0.5 m length)
- ZL-C0-CBL20-1 (1.0 m length)
- ZL-C0-CBL20-2 (2.0 m length)



Input Module Temperature Derating Chart

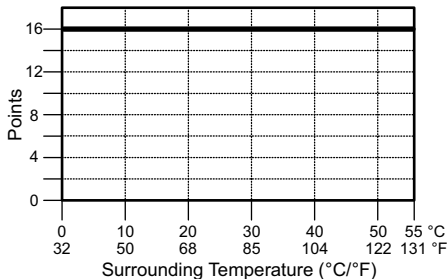

ZL-RTB20 20-pin feed-through connector module



ZL-LTB16-24-1 sensor input module

## C0-08NA – 8-Point AC Input Module

8-point 100–120 VAC input module, 2 commons, isolated, removable terminal block included.

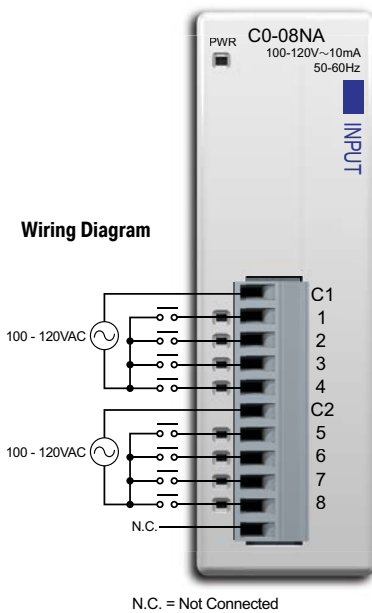

Input Specifications	
<b>Inputs per Module</b>	8
<b>Operating Voltage Range</b>	100–120 VAC
<b>Input Voltage Range</b>	80–144 VAC
<b>AC Frequency</b>	47–63 Hz
<b>Input Current</b>	Typ 8.5 mA @ 100VAC (50Hz) Typ 10mA @ 100VAC (60Hz)
<b>Maximum Input Current</b>	16mA @ 144VAC
<b>Input Impedance</b>	15kΩ (50 Hz), 12kΩ (60Hz)
<b>ON Voltage Level</b>	> 70VAC
<b>OFF Voltage Level</b>	< 20VAC
<b>Minimum ON Current</b>	5mA
<b>Maximum OFF Current</b>	2mA
<b>OFF to ON Response</b>	< 40ms
<b>ON to OFF Response</b>	< 40ms
<b>Status Indicators</b>	Logic Side (8 points, green LED) Power Indicator (green LED)
<b>Commons</b>	2 (4 points/common) Isolated
<b>Bus Power Required (24VDC)</b>	Max. 30mA (All Inputs On)
<b>Terminal Block Replacement</b>	AutomationDirect p/n C0-8TB
<b>Weight</b>	2.8 oz (80g)

### Equivalent Input Circuit

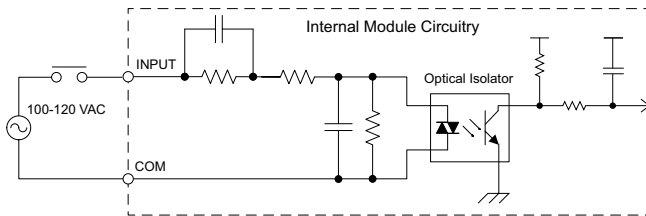

### Z/PLink Pre-Wired PLC Connection Cables and Modules for CLICK PLC

- 11-pin connector cable
- ZL-C0-CBL11 (0.5 m length)
- ZL-C0-CBL11-1 (1.0 m length)
- ZL-C0-CBL11-2 (2.0 m length)



### Input Module Temperature Derating Chart

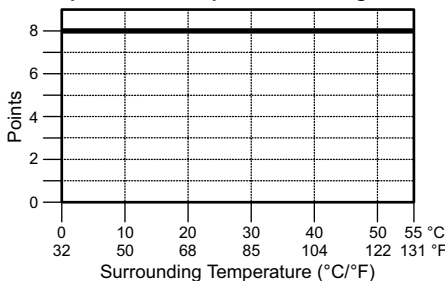

ZL-RTB20  
20-pin feed-through  
connector module



### C0-08TD1 – 8-Point Sinking DC Output Module

8-point 3.3–27 VDC current sinking output module, 2 commons, 0.3 A/pt, removable terminal block included.

Wiring Diagram

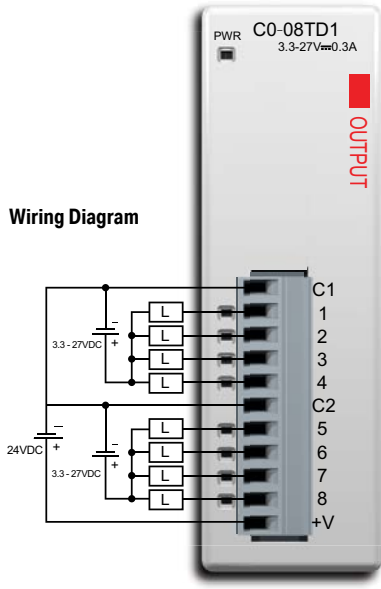

Output Specifications	
Outputs per Module	8 (Sink)
Operating Voltage Range	3.3–27 VDC
Output Voltage Range	2.8–30 VDC
Maximum Output Current	0.3 A/point , 1.2 A/common
Minimum Output Current	0.5 mA
Maximum Leakage Current	0.1 mA @ 30.0 VDC
On Voltage Drop	1.5 VDC @ 0.3 A
Maximum Inrush Current	1A for 10ms
OFF to ON Response	< 0.5 ms
ON to OFF Response	< 0.5 ms
Status Indicators	Logic Side (8 points, red LED) Power Indicator (green LED)
Commons	2 (4 points/common)
External DC Power Required	21.6–26.4 VDC Max 15mA (All Outputs On)
Bus Power Required (24VDC)	Max. 50mA (All Outputs On)
Terminal Block Replacement	AutomationDirect p/n C0-8TB
Weight	2.8 oz (80g)

Equivalent Output Circuit

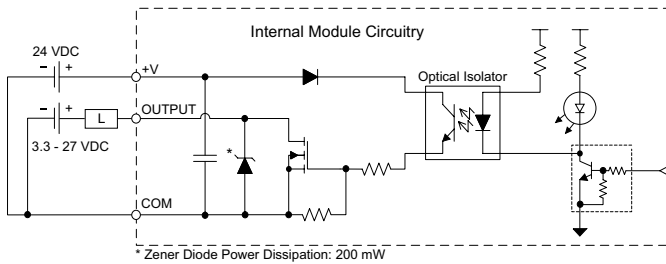

Z/PLink Pre-Wired PLC Connection Cables and Modules for CLICK PLC

- 11-pin connector cable
- ZL-C0-CBL11 (0.5 m length)
- ZL-C0-CBL11-1 (1.0 m length)
- ZL-C0-CBL11-2 (2.0 m length)



Output Module Temperature Derating Chart

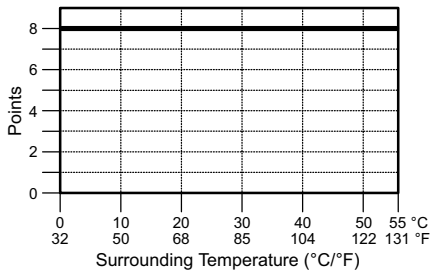

ZL-RTB20  
20-pin feed-through connector module



## C0-08TD2 – 8-Point Sourcing DC Output Module

8-point 12–24VDC current sourcing output module, 1 common, 0.3 A/pt, removable terminal block included.

Wiring Diagram

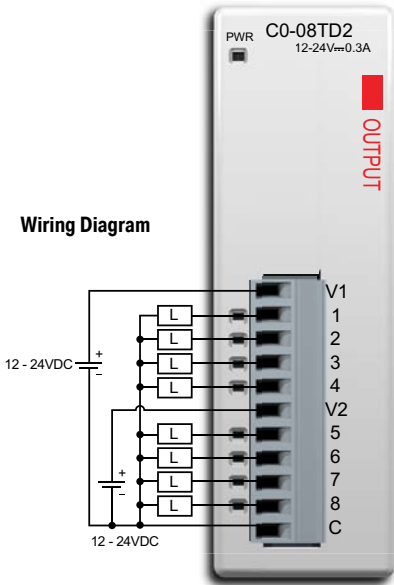

Output Specifications	
Outputs per Module	8 (Source)
Operating Voltage Range	12–24VDC
Output Voltage Range	9.6–30 VDC
Maximum Output Current	0.3 A/point, 1.2 A/common
Minimum Output Current	0.5 mA
Maximum Leakage Current	0.1 mA @ 30.0 VDC
On Voltage Drop	1.5 VDC @ 0.3 A
Maximum Inrush Current	1A for 10ms
OFF to ON Response	< 1ms
ON to OFF Response	< 1ms
Status Indicators	Logic Side (8 points, red LED) Power Indicator (green LED)
Commons	1 (8 points/common)
Bus Power Required (24VDC)	Max. 50mA (All Outputs On)
Terminal Block Replacement	AutomationDirect p/n C0-8TB
Weight	2.8 oz (80g)

Equivalent Output Circuit

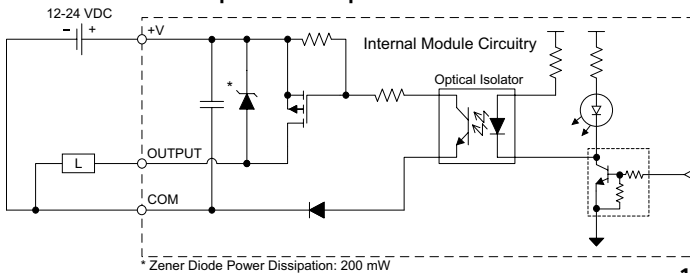

Z/PLink Pre-Wired PLC Connection Cables and Modules for CLICK PLC



- 11-pin connector cable
- ZL-C0-CBL11 (0.5 m length)
- ZL-C0-CBL11-1 (1.0 m length)
- ZL-C0-CBL11-2 (2.0 m length)

Output Module Temperature Derating Chart

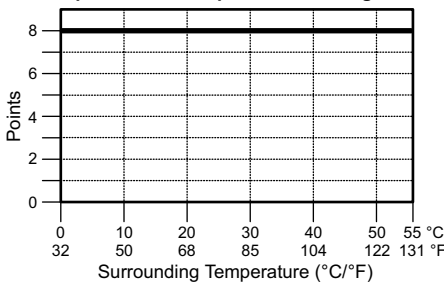

ZL-RTB20  
20-pin feed-through connector module



## C0-16TD1 – 16-Point Sinking DC Output Module

16-point 5–27 VDC current sinking output module, 2 commons, isolated, 0.1 A/pt, removable terminal block included.

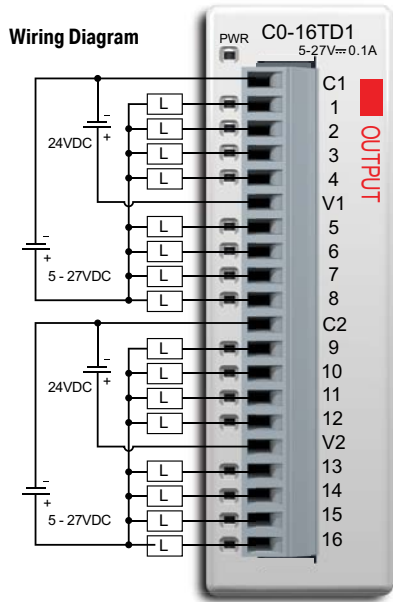

Output Specifications	
Outputs per Module	16 (Sink)
Operating Voltage Range	5–27 VDC
Output Voltage Range	4–30 VDC
Maximum Output Current	0.1 A/point, 0.8 A/common
Minimum Output Current	0.2 mA
Maximum Leakage Current	0.1 mA @ 30.0 VDC
On Voltage Drop	0.5 VDC @ 0.1 A
Maximum Inrush Current	150mA for 10ms
OFF to ON Response	< 0.5 ms
ON to OFF Response	< 0.5 ms
Status Indicators	Logic Side (16 points, red LED) Power Indicator (green LED)
Commons	2 (8 Points/common) Isolated
External DC Power Required	21.6–26.4 VDC Max 100mA (All Outputs On)
Bus Power Required (24VDC)	Max. 80mA (All Outputs On)
Terminal Block Replacement	AutomationDirect p/n C0-16TB
Weight	3.2 oz (90g)

ZIPLink Pre-Wired PLC Connection Cables and Modules for CLICK PLC

### Equivalent Output Circuit

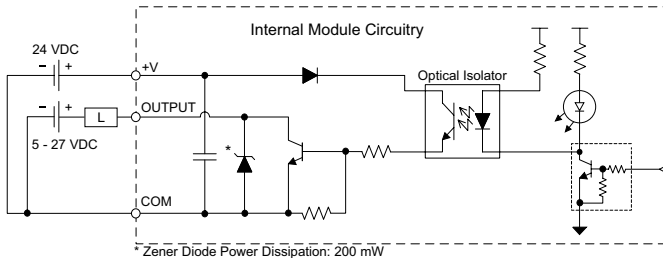

20-pin connector cable  
 ZL-C0-CBL20 (0.5 m length)  
 ZL-C0-CBL20-1 (1.0 m length)  
 ZL-C0-CBL20-2 (2.0 m length)

### Output Module Temperature Derating Chart

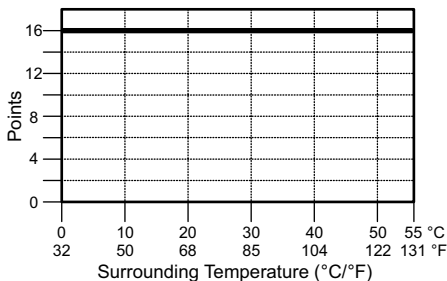

## C0-16TD2 – 16-Point Sourcing Output Module

16-point 12–24 VDC current sourcing output module, 2 commons, isolated, 0.1 A/pt, removable terminal block included.

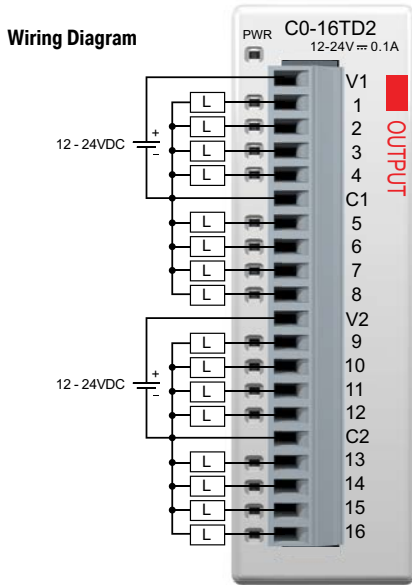

Output Specifications	
Outputs per Module	16 (Source)
Operating Voltage Range	12–24VDC
Output Voltage Range	9.6–30.0 VDC
Maximum Output Current	0.1 A/point, 0.8 A/common
Minimum Output Current	0.2 mA
Maximum Leakage Current	0.1 mA @ 30.0 VDC
On Voltage Drop	0.6 VDC @ 0.1 A
Maximum Inrush Current	150mA for 10ms
OFF to ON Response	< 0.5 ms
ON to OFF Response	< 0.5 ms
Status Indicators	Logic Side (16 points, red LED) Power Indicator (green LED)
Commons	2 (8 points/common) Isolated
Bus Power Required (24VDC)	Max. 80mA (All Outputs On)
Terminal Block Replacement	AutomationDirect p/n C0-16TB
Weight	3.2 oz (90g)

### Equivalent Output Circuit

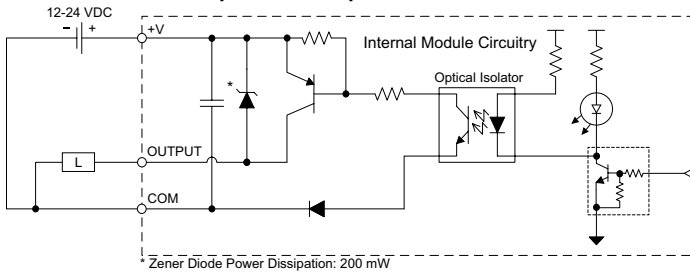

### Z/PLink Pre-Wired PLC Connection Cables and Modules for CLICK PLC



- 20-pin connector cable
- ZL-C0-CBL20 (0.5 m length)
- ZL-C0-CBL20-1 (1.0 m length)
- ZL-C0-CBL20-2 (2.0 m length)

### Output Module Temperature Derating Chart

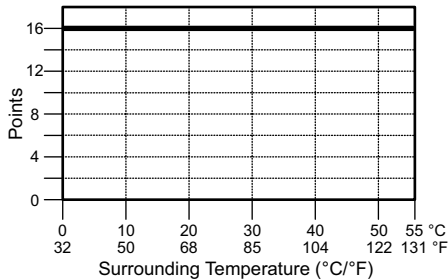

ZL-RTB20 20-pin feed-through connector module



ZL-RFU20 fuse module



ZL-RRL16-24-2 relay module  
Note: 10A/Point (DC)  
8A/Point (AC)  
(Replaceable relays)



### C0-08TA – 8-Point AC Output Module

8-point 17-240 VAC triac output module, 2 commons, isolated, 0.3 A/pt, removable terminal block included.

**Wiring Diagram**

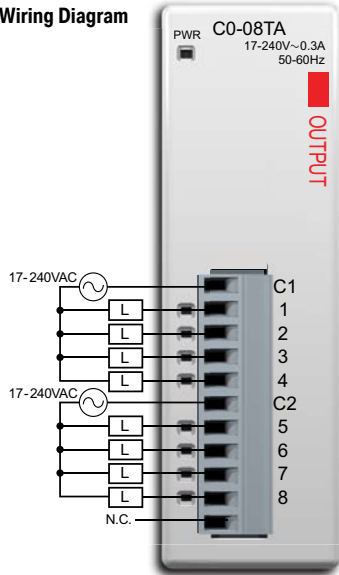

N.C. = Not Connected

Output Specifications	
<b>Outputs per Module</b>	8
<b>Operating Voltage Range</b>	17-240 VAC
<b>Output Voltage Range</b>	13.5-288 VAC
<b>AC Frequency</b>	47-63 Hz
<b>Maximum Output Current</b>	0.3 A/point, 1.2 A/common
<b>Minimum Load</b>	10mA
<b>Maximum Leakage Current</b>	4mA @ 288 VAC
<b>On Voltage Drop</b>	1.5 VAC @ > 0.1 A
	3.0 VAC @ < 0.1 A
<b>Maximum Inrush Current</b>	10A for 10ms
<b>OFF to ON Response</b>	1ms
<b>ON to OFF Response</b>	1ms + 1/2 cycle
<b>Status Indicators</b>	Logic Side (8 points, red LED) Power Indicator (green LED)
<b>Commons</b>	2 (4 points/common) Isolated
<b>Bus Power Required (24VDC)</b>	Max. 80mA (All Outputs On)
<b>Protection Circuit</b>	Not built into the module - Install protection elements such as external fuse.
<b>Terminal Block Replacement</b>	AutomationDirect p/n C0-8TB
<b>Weight</b>	3.5 oz (100g)

**Equivalent Output Circuit**

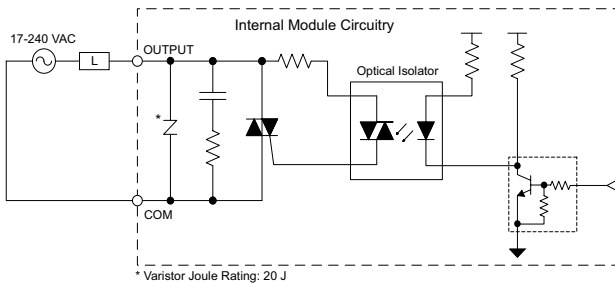

**Z/PLink Pre-Wired PLC Connection Cables and Modules for CLICK PLC**

- 11-pin connector cable
- ZL-C0-CBL11 (0.5 m length)
- ZL-C0-CBL11-1 (1.0 m length)
- ZL-C0-CBL11-2 (2.0 m length)



**Output Temperature Derating Chart**

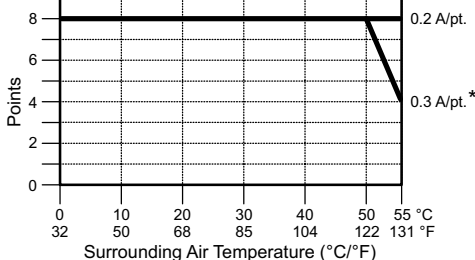

\* Use every other output.

**ZL-RTB20**  
20-pin feed-through connector module



## C0-04TRS – 4-Point Relay Output Module

4-point 6–240 VAC / 6–27VDC Isolated relay output module, 4 Form C (SPDT) relays, 4 isolated commons, 7 A/point, removable terminal block included.

Wiring Diagram

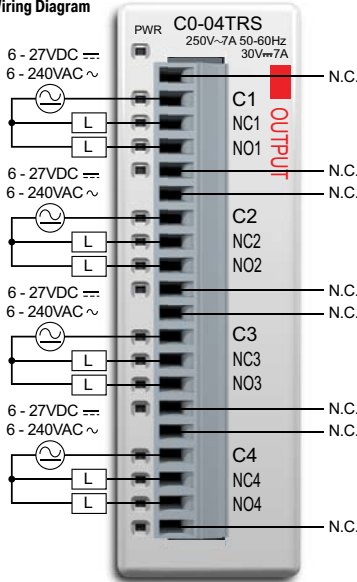

N.C. = Not Connected

Output Specifications	
<b>Outputs per Module</b>	4
<b>Operating Voltage Range</b>	6–27 VDC / 6–240 VAC
<b>Output Voltage Range</b>	5–30 VDC / 5–264 VAC
<b>Output Type</b>	Relay, form C (SPDT)
<b>AC Frequency</b>	47–63 Hz
<b>Maximum Current</b>	7A / point, 7A / common
<b>Minimum Load Current</b>	100mA @ 5VDC
<b>Maximum Leakage Current</b>	0.1 mA @ 264VAC
<b>Maximum Inrush Current</b>	12A
<b>OFF to ON Response</b>	< 15ms
<b>ON to OFF Response</b>	< 15ms
<b>Status Indicators</b>	Logic Side (4 points, red LED) Power Indicator (green LED)
<b>Commons</b>	4 (1 point/common) Isolated
<b>Bus Power Required (24VDC)</b>	Max. 100mA (All Outputs On)
<b>Protection Circuit</b>	Not built into the module - Install protection elements such as external fuse.
<b>Terminal Block Replacement</b>	AutomationDirect p/n C0-16TB
<b>Weight</b>	4.4 oz (125g)

Equivalent Output Circuit

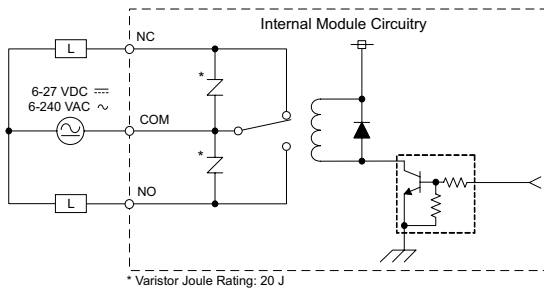

\* Varistor Joule Rating: 20 J

Output Temperature Derating Chart

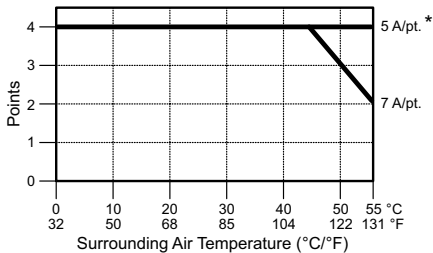

\* No derating when the load current is 5A or less for each output point.

Typical Relay Life (Operations) at Room Temperature

Voltage & Load Type	Relay Life
30VDC, 7A Resistive	100,000 cycles
250VAC, 7A Resistive	100,000 cycles
250VAC, 4.9 A Solenoid	90,000 cycles
250VAC, 2.9 A Solenoid	100,000 cycles
ON to OFF = 1 cycle	

ZIPLink Pre-Wired PLC Connection

Cables and Modules for CLICK PLC



20-pin connector cable  
 ZL-C0-CBL20 (0.5 m length)  
 ZL-C0-CBL20-1 (1.0 m length)  
 ZL-C0-CBL20-2 (2.0 m length)

ZL-RTB20  
 20-pin feed-through connector module

**NOTE:** The C0-04TRS relay output module is derated to 2A per point maximum when used with the ZIPLink wiring system.

### C0-04TRS-10 – 4-Point Relay Output Module

4-point 6–240 VAC / 6–24VDC Isolated relay output module, 4 Form A (SPST) relays, 4 isolated commons, 10A/point, removable terminal block included.

Wiring Diagram

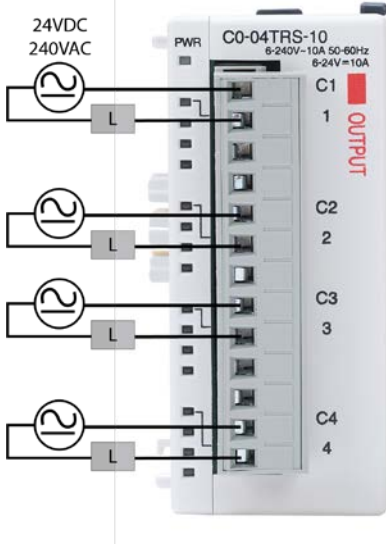

Output Specifications	
<b>Outputs per Module</b>	4
<b>Operating Voltage Range</b>	6–24 VDC / 6–240 VAC
<b>Peak Voltage</b>	24VDC / 264VAC
<b>Output Type</b>	Relay, form A (SPST)
<b>AC Frequency</b>	47–63 Hz
<b>Maximum Current</b>	10A / point, 10A / common
<b>Minimum Load Current</b>	100mA @ 5VDC
<b>Maximum Inrush Current</b>	16A for 10ms
<b>OFF to ON Response</b>	< 15ms
<b>ON to OFF Response</b>	< 15ms
<b>Status Indicators</b>	Logic Side (4 points, red LED) Power Indicator (green LED)
<b>Commons</b>	4 (1 point/common) Isolated
<b>Bus Power Required (24VDC)</b>	Max. 120mA (All Outputs On)
<b>Protection Circuit</b>	Not built into the module - Install protection elements such as external fuse.
<b>Terminal Block Replacement</b>	AutomationDirect p/n C0-8TB-1
<b>Weight</b>	5.22 oz (148g)

Typical Relay Life (Operations) at Room Temperature	
Voltage & Load Type	Relay Life
24VDC, 10A Resistive	120,000 cycles
24VDC, 10A Inductive	60,000 cycles
110VAC, 10A Resistive	120,000 cycles
110VAC, 10A Inductive	35,000 cycles
220VAC, 10A Resistive	120,000 cycles
220VAC, 10A Inductive	35,000 cycles
ON to OFF = 1 cycle	

Output Temperature Derating Chart

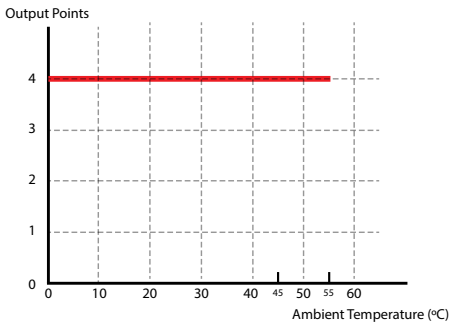

Equivalent Output Circuit

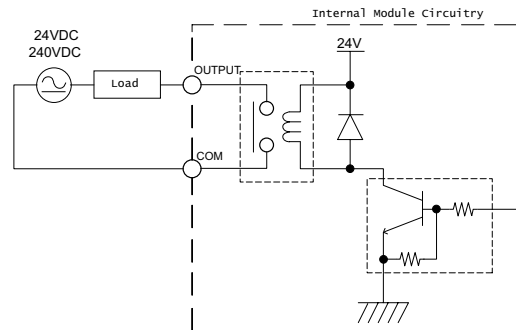

## C0-08TR – 8-Point Relay Output Module

8-point 6–240 VAC / 6–27 VDC relay output module, 8 Form A (SPST) relays, 2 commons, isolated, 4 A/common, removable terminal block included.

Wiring Diagram

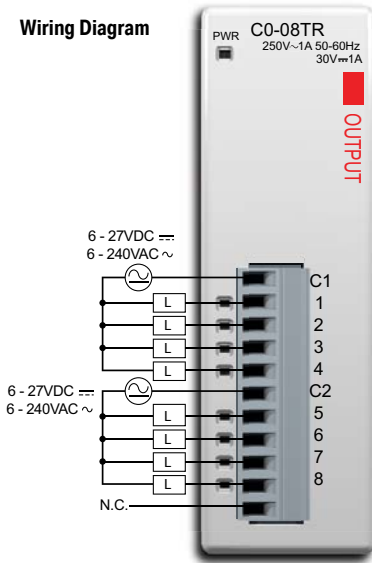

N.C. = Not Connected

Output Specifications	
Outputs per Module	8
Operating Voltage Range	6–27 VDC / 6–240 VAC
Output Voltage Range	5–30 VDC / 5–264 VAC
Output Type	Relay, form A (SPST)
AC Frequency	47–63 Hz
Maximum Current (resistive)	1A /point, 4A /common
Minimum Load Current	5mA @ 5VDC
Maximum Leakage Current	0.1 mA @ 264VAC
Maximum Inrush Current	3A for 10ms
OFF to ON Response	< 15ms
ON to OFF Response	< 15ms
Status Indicators	Logic Side (8 points, red LED) Power Indicator (green LED)
Commons	2 (4 points/common) Isolated
Bus Power Required (24VDC)	Max. 100mA (All Outputs On)
Protection Circuit	Not built into the module - Install protection elements such as external fuse.
Terminal Block Replacement	AutomationDirect p/n C0-8TB
Weight	3.9 oz (110g)

Equivalent Output Circuit

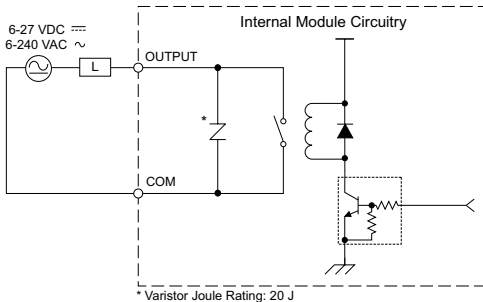

Typical Relay Life (Operations) at Room Temperature

Voltage & Load Type	Relay Life
30VDC, 1A Resistive	300,000 cycles
30VDC, 1A Solenoid	50,000 cycles
250VAC, 1A Resistive	500,000 cycles
250VAC, 1A Solenoid	200,000 cycles

ON to OFF = 1 cycle

Output Temperature Derating Chart

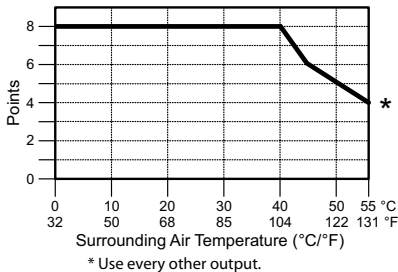

ZIPLink Pre-Wired PLC Connection Cables and Modules for CLICK PLC



- 11-pin connector cable
- ZL-C0-CBL11 (0.5 m length)
- ZL-C0-CBL11-1 (1.0 m length)
- ZL-C0-CBL11-2 (2.0 m length)



ZL-RTB20  
20-pin feed-through  
connector module



**NOTE:** The C0-08TR is derated to 2A maximum per Common when used with the ZIPLink wiring system.

### C0-08TR-3 – 8-Point Relay Output Module

8-point 6–240 VAC /6–27 VDC relay output module, 8 Form A (SPST) relays, 4 commons, isolated, 3A/point, removable terminal block included.

Wiring Diagram

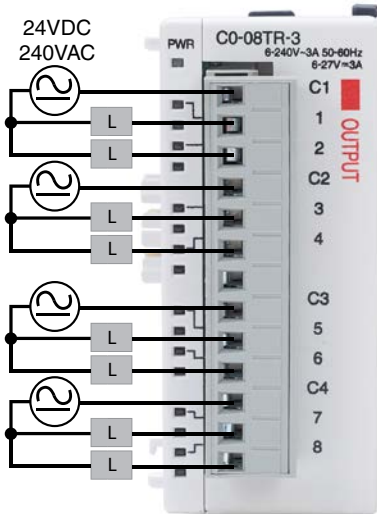

#### Output Specifications

<b>Outputs per Module</b>	8
<b>Operating Voltage Range</b>	6–27 VDC / 6–240 VAC
<b>Peak Voltage</b>	30 VDC / 264 VAC
<b>Output Type</b>	Relay, form A (SPST)
<b>AC Frequency</b>	47–63 Hz
<b>Maximum Current (resistive)</b>	3A /point, 6A /common
<b>Minimum Load Current</b>	5mA @ 5VDC
<b>Maximum Inrush Current</b>	5A for 10ms
<b>OFF to ON Response</b>	< 15ms
<b>ON to OFF Response</b>	< 15ms
<b>Status Indicators</b>	Logic Side (8 points, red LED) Power Indicator (green LED)
<b>Commons</b>	4 (2 points/common) Isolated
<b>Bus Power Required (24VDC)</b>	Max. 90mA (All Outputs ON)
<b>Protection Circuit</b>	Not built into the module - Install protection elements such as external fuse.
<b>Terminal Block Replacement</b>	AutomationDirect p/n C0-8TB-1
<b>Weight</b>	4.12 oz (117g)

#### Typical Relay Life (Operations) at Room Temperature

Voltage & Load Type	Relay Life
24VDC, 3A Resistive	100,000 cycles
24VDC, 3A Inductive	50,000 cycles
110VAC, 3A Resistive	100,000 cycles
110VAC, 3A Inductive	25,000 cycles
220VAC, 3A Resistive	100,000 cycles
220VAC, 3A Inductive	25,000 cycles
ON to OFF = 1 cycle	

Output Temperature Derating Chart

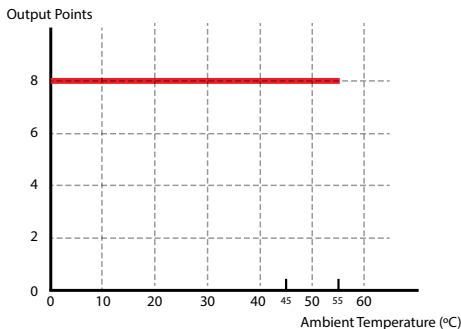

Equivalent Output Circuit

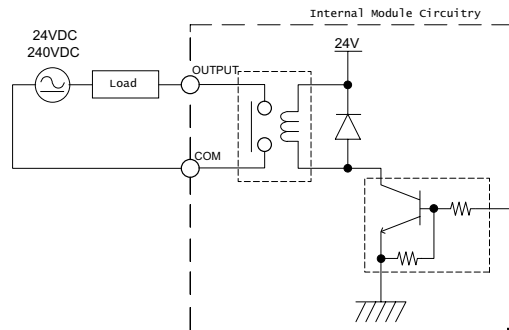

### C0-16CDD1 – 8-Point DC Input and 8-Point DC Sinking Output Module

8-point 24VDC current sinking/sourcing input, 1 common, 8-point 5–27 VDC sinking output, 0.1A/pt., 1 common, non-fused, removable terminal block included.

Wiring Diagram

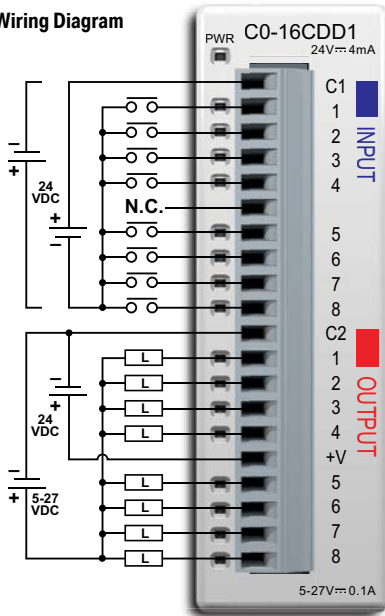

N.C. = Not Connected

Input Specifications	
Inputs per Module	8 (Source/Sink)
Operating Voltage Range	CE: 24VDC (-10%/+10%) UL: 24VDC (-10%/+10%)
Input Voltage Range	21.6–26.4 VDC
Input Current	Typ 4.0 mA @ 24VDC
Maximum Input Current	5.0 mA @ 26.4 VDC
Input Impedance	6.8 kΩ @ 24VDC
ON Voltage Level	>19.0 VDC
OFF Voltage Level	<7.0 VDC
Minimum ON Current	3.5 mA
Maximum OFF Current	0.5 mA
OFF to ON Response	Max. 10ms Typ 2ms
ON to OFF Response	Max. 10ms Typ 3ms
Status Indicators	Logic Side (8 points, green LED) Power Indicator (green LED)
Commons	1 (8 points/common)

General Specifications	
Bus Power Required (24VDC)	Max. 80mA (all points on)
Terminal Block Replacement	AutomationDirect p/n C0-16TB
Weight	3.2 oz (90g)



**NOTE:** When using this module you must also use *CLICK* programming software and PLC firmware version V1.40 or later.

Equivalent Input Circuit

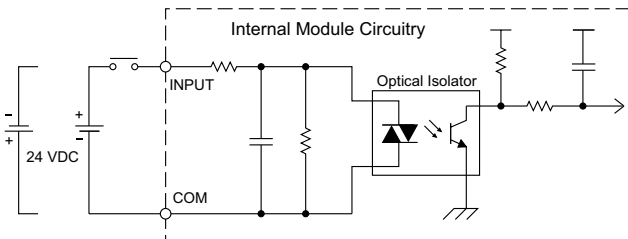

Input Module Temperature Derating Chart

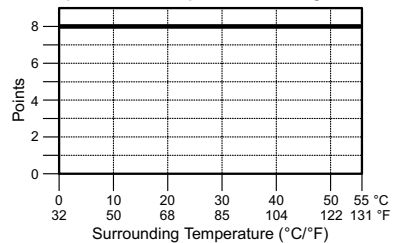

C0-16CDD1 (continued)

Output Specifications	
Outputs per Module	8 (sink) CE: 5-24 VDC (-15%/+20%) UL: 5-27 VDC (-15%/+20%)
Operating Voltage Range	4-30 VDC
Output Voltage Range	0.1 A/point, 0.8 A/common
Maximum Output Current	0.2 mA
Minimum Output Current	0.1 mA @ 30VDC
Maximum Leakage Current	0.5 VDC @ 0.1 A
On Voltage Drop	0.15 A for 10ms
Maximum Inrush Current	< 0.5 ms
OFF to ON Response	< 0.5 ms
ON to OFF Response	Logic Side (8 points, red LED)
Status Indicators	1 (8 points/common)
Commons	24VDC (-10%/+10%) max. 50mA (all points on)

Equivalent Output Circuit

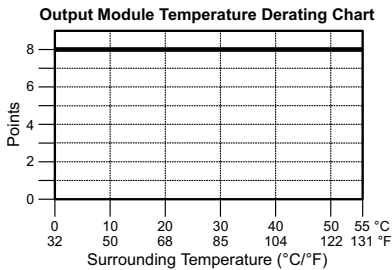
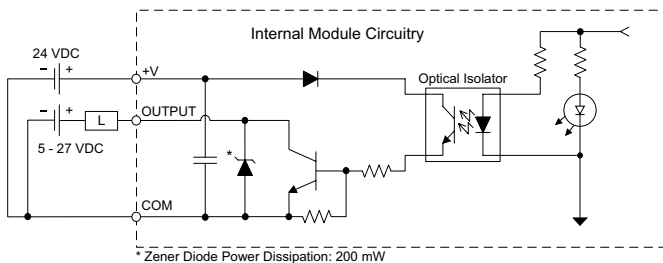

ZIPLink Pre-Wired PLC Connection Cables and Modules for CLICK PLC



ZL-RTB20  
20-pin feed-through  
connector module

- 20-pin connector cable
- ZL-C0-CBL20 (0.5 m length)
- ZL-C0-CBL20-1 (1.0 m length)
- ZL-C0-CBL20-2 (2.0 m length)



### C0-16CDD2 – 8-Point DC Input and 8-Point DC Sourcing Output Module

8-point 24VDC current sinking/sourcing input, 1 common, 8-point 12–24 VDC sourcing output, 0.1A/pt, 1 common, non-fused, removable terminal block included.

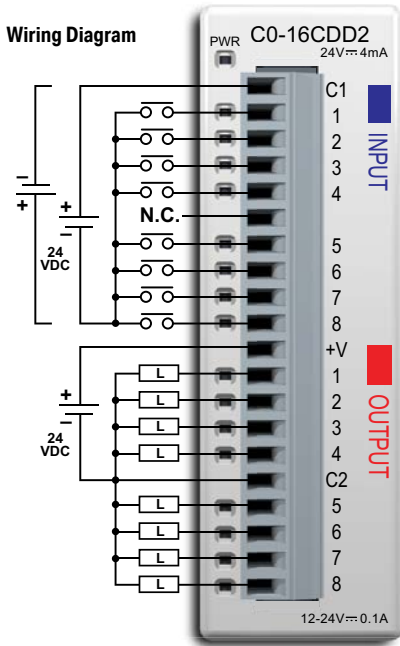

N.C. = Not Connected

Input Specifications	
Inputs per Module	8 (source/sink)
Operating Voltage Range	CE: 24VDC (-10%/+10%) UL: 24VDC (-10%/+10%)
Input Voltage Range	21.6–26.4 VDC
Input Current	Typ 4.0 mA @ 24VDC
Maximum Input Current	5.0 mA @ 26.4 VDC
Input Impedance	6.8 kΩ @ 24VDC
ON Voltage Level	>19.0 VDC
OFF Voltage Level	<7.0 VDC
Minimum ON Current	3.5 mA
Maximum OFF Current	0.5 mA
OFF to ON Response	Max. 10ms Typ 2ms
ON to OFF Response	Max. 10ms Typ 3ms
Status Indicators	Logic Side (8 points, green LED) Power Indicator (green LED)
Commons	1 (8 points/common)

General Specifications	
Bus Power Required (24VDC)	Max. 80mA (all points on)
Terminal Block Replacement	AutomationDirect p/n C0-16TB
Weight	3.2 oz (90g)



**NOTE:** When using this module you must also use CLICK programming software and PLC firmware version V1.40 or later.

#### Equivalent Input Circuit

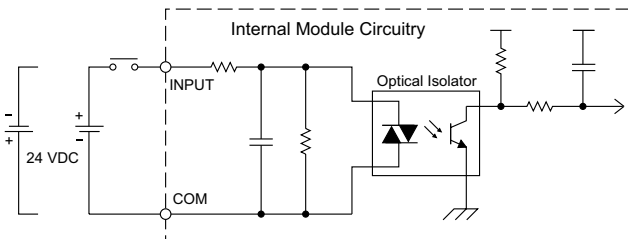

#### Input Module Temperature Derating Chart

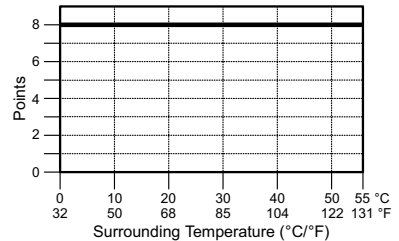

C0-16CDD2 (continued)

Output Specifications	
Outputs per Module	8 (Source)
Operating Voltage Range	CE: 12–24 VDC (-15%/+20%) UL: 12–24 VDC (-20%/+25%)
Output Voltage Range	9.6–30 VDC
Maximum Output Current	0.1 A/point, 0.8 A/common
Minimum Output Current	0.2 mA
Maximum Leakage Current	0.1 mA @ 30VDC
On Voltage Drop	0.6 VDC @ 0.1 A
Maximum Inrush Current	0.15 A for 10ms
OFF to ON Response	<0.5 ms
ON to OFF Response	<0.5 ms
Status Indicators	Logic Side (8 points, red LED)
Commons	1 (8 points/common)

Equivalent Output Circuit

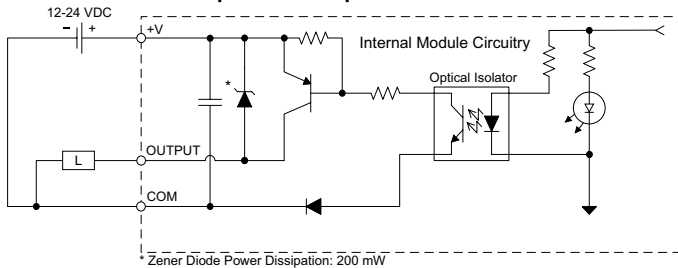

Output Module Temperature Derating Chart

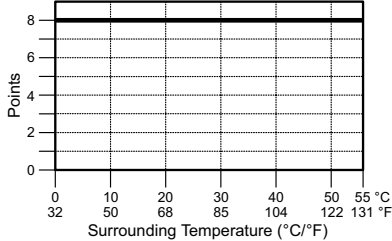

ZIPLink Pre-Wired PLC Connection Cables and Modules for CLICK PLC



**ZL-RTB20**  
20-pin feed-through connector module

- 20-pin connector cable
- ZL-C0-CBL20 (0.5 m length)
- ZL-C0-CBL20-1 (1.0 m length)
- ZL-C0-CBL20-2 (2.0 m length)



## C0-08CDR – 4-Point DC Input and 4-Point Relay Output Module

4-point 12–24 VDC current sinking/sourcing input, 1 common, 4-point 6.25–24 VDC / 6–240 VAC relay output, Form A (SPST) relays 1A/pt, 1 common, non-fused, removable terminal block included.

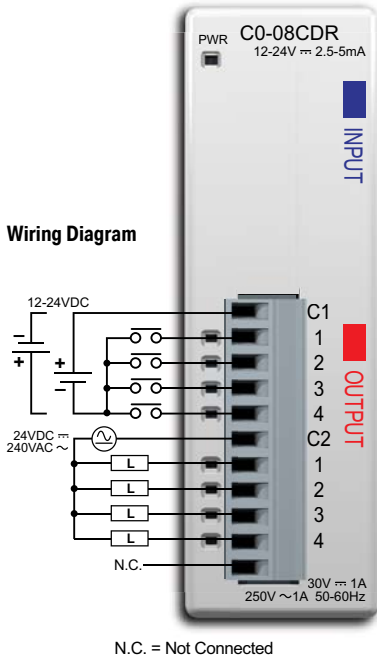

Input Specifications	
<b>Inputs per Module</b>	4 (source/sink)
<b>Operating Voltage Range</b>	CE: 12–24 VDC (-10%/+10%) UL: 12–24 VDC (-10%/+10%)
<b>Input Voltage Range</b>	10.8–26.4 VDC
<b>Input Current</b>	Typ 5.0 mA @ 24VDC
<b>Maximum Input Current</b>	7.0 mA @ 26.4 VDC
<b>Input Impedance</b>	4.7 kΩ @ 24VDC
<b>ON Voltage Level</b>	>8.0 VDC
<b>OFF Voltage Level</b>	<3.0 VDC
<b>Minimum ON Current</b>	1.4 mA
<b>Maximum OFF Current</b>	0.5 mA
<b>OFF to ON Response</b>	Max. 3.5 ms Typ 2ms
<b>ON to OFF Response</b>	Max. 4ms Typ 2.5 ms
<b>Status Indicators</b>	Logic Side (4 points, green LED) Power Indicator (green LED)
<b>Commons</b>	1 (4 points/common)

General Specifications	
<b>Bus Power Required (24VDC)</b>	Max. 80mA (all points on)
<b>Protection Circuit</b>	Not built into the module - Install protection elements such as external fuse
<b>Terminal Block Replacement</b>	AutomationDirect p/n C0-8TB
<b>Weight</b>	3.2 oz (90g)



**NOTE:** When using this module you must also use CLICK programming software and PLC firmware version V1.40 or later.

### Equivalent Input Circuit

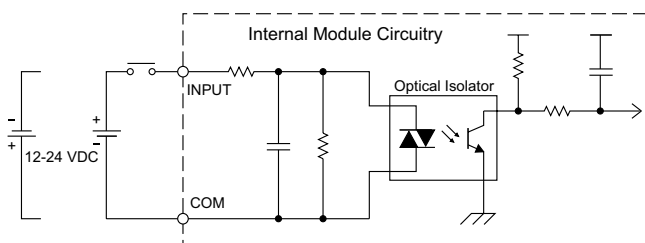

### Input Temperature Derating Chart

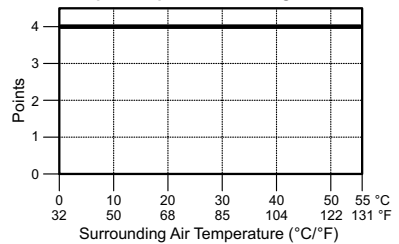

C0-08CDR (continued)

Output Specifications	
Outputs per Module	4 (Relay)
Operating Voltage Range	CE: 6.25–24 VDC (-15%/+10%) / 6–240 VAC (-15%/+10%) UL: 24VDC (-15%/+10%) / 240VAC (-10%/+10%)
Peak Voltage	30VDC / 264VAC
Output Type	Relay, Form A (SPST)
AC Frequency	47–63 Hz
Maximum Current	1A /point, 4 A/common
Minimum Load Current	5mA @ 5VDC
Maximum Leakage Current	0.1 mA @ 264VAC
Maximum Inrush Current	3A for 10ms
OFF to ON Response	<15ms
ON to OFF Response	<15ms
Status Indicators	Logic Side (4 points, red LED)
Commons	1 (4 points/common)

Typical Relay Life (Operations) at Room Temperature	
Voltage & Load Type*	Relay Life (ON to OFF = 1 cycle)
30VDC, 1A, Resistive	80,000 cycles
30VDC, 1A, Solenoid	80,000 cycles
250VAC, 1A, Resistive	80,000 cycles
250VAC, 1A, Solenoid	80,000 cycles

\* These relay outputs support both inductive (solenoid) and resistive loads.

Equivalent Output Circuit

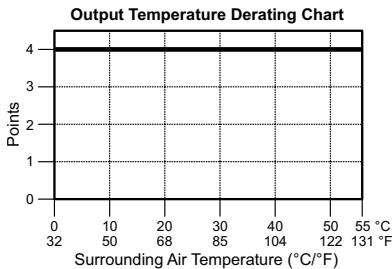
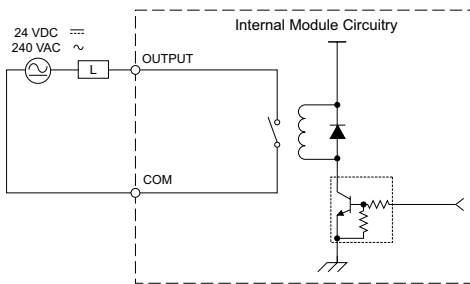

ZIPLink Pre-Wired PLC Connection Cables and Modules for CLICK PLC



ZL-RTB20  
20-pin feed-through connector module



11-pin connector cable  
ZL-C0-CBL11 (0.5 m length)  
ZL-C0-CBL11-1 (1.0 m length)  
ZL-C0-CBL11-2 (2.0 m length)

### C0-04AD-1 – 4-Channel Analog Current Input Module

4-channel analog current sinking input module, 13-bit resolution, range: 0–20 mA. External 24VDC power required, removable terminal block included.

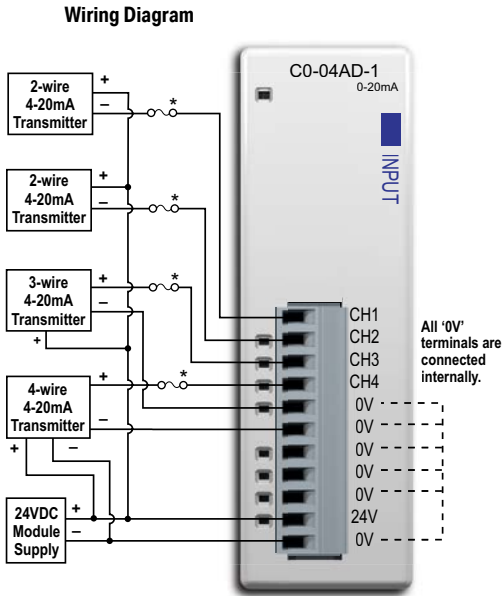

**NOTE:** When using this module you must also use CLICK programming software and PLC firmware version V1.40 or later.

Input Specifications	
Inputs per Module	4
Input Range	0–20 mA (sink)
Resolution	13-bit, 2.44 $\mu$ A/count
Input Type	Single ended (one common)
Maximum Continuous Overload	$\pm$ 44mA
Input Impedance	124 $\Omega$ , 0.5 W current input
Filter Characteristics	Low pass, -3 dB at 120Hz
Sample Duration Time	2ms
All Channel Update Rate	25ms
Open Circuit Detection Time	Zero reading within 100ms
Accuracy vs. Temperature	$\pm$ 75 PPM/ $^{\circ}$ C maximum
Maximum Inaccuracy	0.5% of range (including temperature changes)
Linearity Error (End to End)	$\pm$ 3 count maximum, monotonic with no missing codes
Input Stability and Repeatability	$\pm$ 2 count maximum
Full Scale Calibration Error (including Offset)	$\pm$ 8 count maximum
Offset Calibration Error	$\pm$ 8 count maximum
Maximum Crosstalk at DC, 50/60 Hz	$\pm$ 2 count maximum
Field to Logic Side Isolation	1800VAC for 1 sec.
Recommended Fuse (external)	AutomationDirect p/n S500-32-R (0.032A fuse)
External 24VDC Power Required	65mA
Bus Power Required (24VDC)	20mA
Terminal Block Replacement	AutomationDirect p/n C0-8TB
Weight	2.9 oz (82g)

#### ZIPLink Pre-Wired PLC Connection Cables and Modules for CLICK PLC



ZL-RTB20 20-pin feed-through connector module



11-pin connector cable  
 ZL-C0-CBL11 (0.5 m length)  
 ZL-C0-CBL11-1 (1.0 m length)  
 ZL-C0-CBL11-2 (2.0 m length)

### C0-04AD-2 – 4-Channel Analog Voltage Input Module

4-channel analog voltage input module, 13-bit resolution, range: 0–10V. External 24VDC power required, removable terminal block included.

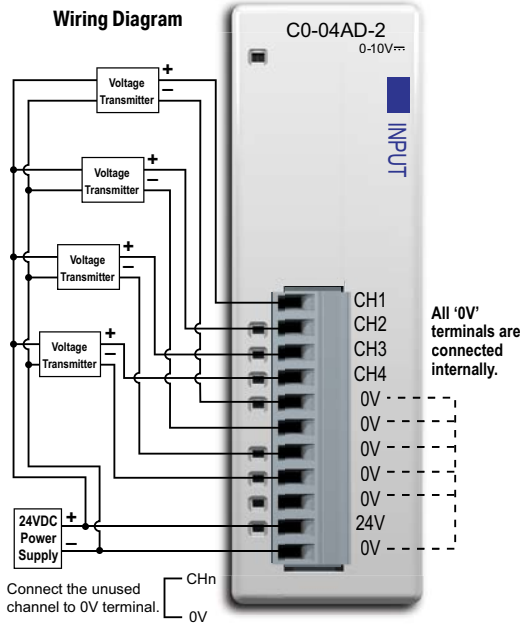

**NOTE:** When using this module you must also use **CLICK programming software and PLC firmware version V1.40 or later.**

Input Specifications	
Inputs per Module	4
Input Range	0–10 V
Resolution	13-bit, 1.22 mV per count
Input Type	Single ended (one common)
Maximum Continuous Overload	±100VDC
Input Impedance	>150kΩ
Filter Characteristics	Low pass, -3 dB at 500Hz
Sample Duration Time	6.25 ms
All Channel Update Rate	25ms
Open Circuit Detection Time	Zero reading within 100 ms
Accuracy vs. Temperature	±75 PPM/°C maximum
Maximum Inaccuracy	0.5% of range (including temperature changes)
Linearity Error (End to End)	±3 count maximum, monotonic with no missing codes
Input Stability and Repeatability	±2 count maximum
Full Scale Calibration Error (Including Offset)	±8 count maximum
Offset Calibration Error	±8 count maximum
Maximum Crosstalk at DC, 50/60 Hz	±2 count maximum
Field to Logic Side Isolation	1800VAC for 1 sec.
External 24VDC Power Required	65mA
Base Power Required (24VDC)	23mA
Terminal Block Replacement	AutomationDirect p/n C0-8TB
Weight	2.9 oz (82g)

#### ZIPLink Pre-Wired PLC Connection Cables and Modules for CLICK PLC



- 11-pin connector cable
- ZL-C0-CBL11 (0.5 m length)
- ZL-C0-CBL11-1 (1.0 m length)
- ZL-C0-CBL11-2 (2.0 m length)



## C0-04RTD – 4-Channel RTD Input Module

4-channel RTD input module, 16-bit resolution ( $\pm 0.1$  degrees Celsius or Fahrenheit), supports: Pt100, Pt1000, jPt100, Cu10, Cu25, Ni120. Resistive ranges also supported, removable terminal block included.

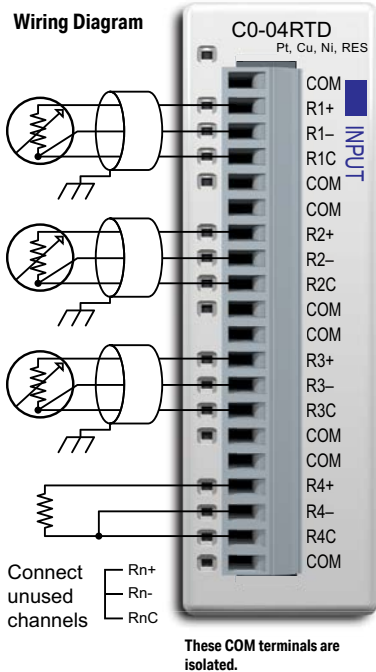

These COM terminals are isolated.



**NOTE:** The C0-04RTD module cannot be used with thermistors.



**NOTE:** When using this module you must also use CLICK programming software and PLC firmware version V1.40 or later.

If there are any unused channels, make sure to select the correct number of channels that you actually use in the C0-04RTD Setting window.

General Specifications	
Field to Logic Side Isolation	No isolation
External DC Power Required	None
Bus Power Required (24VDC)	25mA
Thermal Dissipation	2.047 BTU per hour
Terminal Block Replacement	AutomationDirect p/n C0-16TB
Weight	3.1 oz (86g)

Input Specifications	
Inputs per Module	4
Common Mode Range	$\pm 2.5$ V
Common Mode Rejection	100dB at DC and 100 dB at 50/60 Hz
Input Impedance	>5M $\Omega$
Maximum Ratings	Fault protected inputs to $\pm 50$ VDC
Resolution	$\pm 0.1^\circ\text{C}$ or $^\circ\text{F}$ , 0.1 $\Omega$ or 0.01 $\Omega$
Input Ranges*	Pt100: -200 to 850 $^\circ\text{C}$ (-328 to 1562 $^\circ\text{F}$ )
	Pt1000: -200 to 595 $^\circ\text{C}$ (-328 to 1103 $^\circ\text{F}$ )
	jPt100: -100 to 450 $^\circ\text{C}$ (-148 to 842 $^\circ\text{F}$ )
	10 $\Omega$ Cu: -200 to 260 $^\circ\text{C}$ (-328 to 500 $^\circ\text{F}$ )
	25 $\Omega$ Cu: -200 to 260 $^\circ\text{C}$ (-328 to 500 $^\circ\text{F}$ )
	120 $\Omega$ Ni: -80 to 260 $^\circ\text{C}$ (-112 to 500 $^\circ\text{F}$ )
	0 to 3125.0 $\Omega$ : Resolution 0.1 $\Omega$
0 to 1562.5 $\Omega$ : Resolution 0.1 $\Omega$	
0 to 781.2 $\Omega$ : Resolution 0.1 $\Omega$	
0 to 390.62 $\Omega$ : Resolution 0.01 $\Omega$	
0 to 195.31 $\Omega$ : Resolution 0.01 $\Omega$	
RTD Linearization	Automatic
Excitation Current (All Ranges)	210 $\mu\text{A}$

\* While it is possible to use different resistive ranges, we recommend using the narrowest range that covers the resistance being measured. For example, if measuring approximately 100 ohms resistance, use the 0 to 195.31 ohms range. While the resolution is the same as the 0 to 390.62 ohms range, output RMS noise will be lower and stability will be improved.

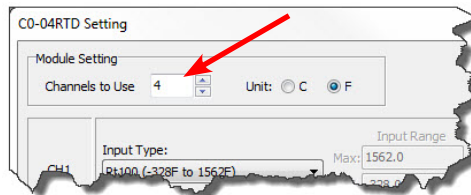

## C0-04RTD – 4-Channel RTD Input Module (continued)

Input Specifications (continued)	
Accuracy vs. Temperature	±10ppm per °C maximum
RTD Input Maximum Inaccuracy	±3°C (excluding RTD error); ±5°C (ranges Cu10 and Cu25)
RTD Linearity Error (End to End)	±2°C maximum, ±0.5°C typical, monotonic with no missing codes
Resistance Input Maximum Zero Scale Error	±0.0015% of full scale range in ohms (negligible)
Resistance Input Maximum Full Scale Error	±0.02% of full scale range
Maximum Linearity Error	±0.015% of full scale range maximum at 25°C, monotonic with no missing codes
Resistance Maximum Input Inaccuracy	0.1% at 0 to 60°C (32° to 140° F), typical 0.04% at 25°C (77° F)
Warm Up Time	30 minutes for ±1°C repeatability
Single Channel Update Rate	240ms
All Channel Update Rate	Single Channel Update Rate times the number of enabled channels on the module
Open Circuit Detection Time	Positive full-scale reading within 2 seconds
Conversion Method	Sigma - Delta

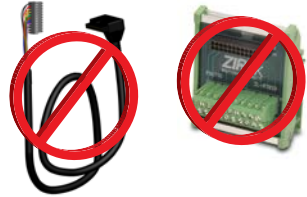

Not Compatible with ZIPLink  
Pre-Wired PLC Connection  
Cables and Modules.



**NOTE:** When this module is used in a CLICK PLC system, it takes up to 24 seconds for initialization after power-up. During this time period, the RUN LED on the PLC module blinks to indicate the initialization process.

Initialization Time		
The Number of Channels Used	The same Input Type is selected for all Channels	Mixed Input Types are selected
1	4 sec	N/A
2	5 sec	May take up to 13 sec
3	6 sec	May take up to 18 sec
4	7 sec	May take up to 24 sec

## C0-04THM – 4-Channel Thermocouple Input Module

4-channel thermocouple input module, 16-bit resolution ( $\pm 0.1$  degrees Celsius or Fahrenheit), Supports: J, K, E, R, S, T, B, N, C type thermocouples; voltages ranges also supported, removable terminal block included.

Wiring Diagram

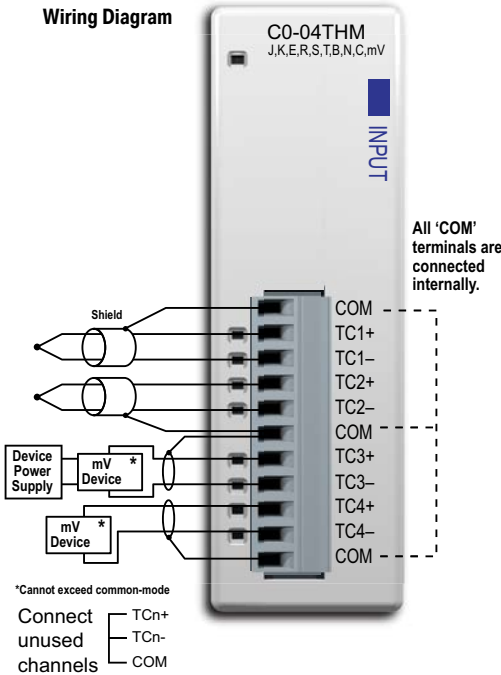

General Specifications	
Field to Logic Side Isolation	1800 VAC applied for 1 second (100% tested)
External DC Power Required	None
Bus Power Required (24VDC)	25mA
Thermal Dissipation	0.175 BTU per hour
Terminal Block Replacement	AutomationDirect p/n C0-8TB
Weight	3.1 oz (86 g)

Input Specifications	
Inputs per Module	4
Common Mode Range	-1.3 to +3.8 V
Common Mode Rejection	100dB at DC and 130dB at 60Hz
Input Impedance	>5MΩ
Maximum Ratings	Fault protected inputs to $\pm 50$ VDC
Resolution	$\pm 0.1^\circ\text{C}$ or $^\circ\text{F}$ , 16-bit
Input Ranges	Type J: -190 to 760°C (-310 to 1400°F)
	Type K: -150 to 1372°C (-238 to 2502°F)
	Type E: -210 to 1000°C (-346 to 1832°F)
	Type R: 65 to 1768°C (149 to 3214°F)
	Type S: 65 to 1768°C (149 to 3214°F)
	Type T: -230 to 400°C (-382 to 752°F)
	Type B: 529 to 1820°C (984 to 3308°F)
	Type N: -70 to 1300°C (-94 to 2372°F)
	Type C: 65 to 2320°C (149 to 4208°F)
	0 to 39.0625 mV
$\pm 39.0625$ mV	
$\pm 78.125$ mV	
0 to 156.25 mV	
$\pm 156.25$ mV	
0 to 1.25 V	

**NOTE:** When using this module you must also use CLICK programming software and PLC firmware version V1.40 or later.

If there are any unused channels, make sure to select the correct number of channels that you actually use in the C0-04THM Setting window.

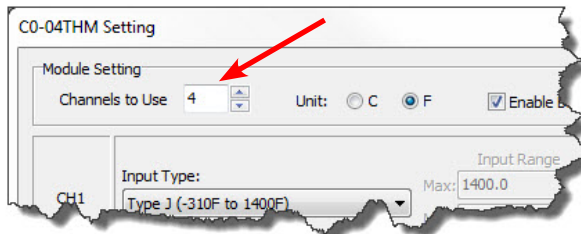

C0-04THM – 4-Channel Thermocouple Input Module (continued)

Input Specifications (continued)	
Cold Junction Compensation	Automatic
Thermocouple Linearization	Automatic
Accuracy vs. Temperature	±25 ppm per °C maximum
Linearity Error	±2°C maximum, ±1°C typical, monotonic with no missing codes
Maximum Inaccuracy	±3°C maximum (excluding thermocouple error)
Maximum Voltage Input Offset Error	0.05% at 0° to 55° C (32° to 131° F), typical 0.04% at 25° C (77° F)
Maximum Voltage Input Gain Error	0.06% at 25°C (77°F)
Maximum Voltage Input Linearity Error	0.05% at 0° to 55°C (32° to 131°F), typical 0.03% at 25°C (77°F)
Maximum Voltage Input Inaccuracy	0.1% at 0° to 55°C (32° to 131°F), typical 0.04% at 25°C (77°F)
Warm Up Time	30 minutes for ±1C° repeatability
Single Channel Update Rate	400ms
All Channel Update Rate	Single Channel Update Rate times the number of enabled channels on the module
Open Circuit Detection Time	Burn Out flag set and zero scale reading within 3 seconds
Conversion Method	Sigma - Delta

Not Compatible with ZIPLink Pre-Wired PLC Connection Cables and Modules.



**NOTE:** When this module is used in a CLICK PLC system, it takes up to 11 seconds for initialization after power-up. During this time period, the RUN LED on the PLC module blinks to indicate the initialization process.

Initialization Time	
The Number of Channels Used	With any Configuration
1	5 sec
2	7 sec
3	9 sec
4	11 sec



**NOTE:** With grounded thermocouples, take precautions to prevent having a voltage potential between thermocouple tips. A voltage less than -1.3V or greater than +3.8V between tips will skew measurements.

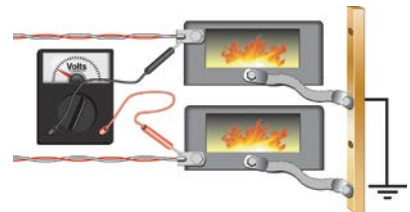

### C0-04DA-1 – 4-Channel Analog Current Output Module

4-channel analog current sourcing output module, 12-bit resolution, range: 4–20 mA. External 24VDC power required, removable terminal block included.

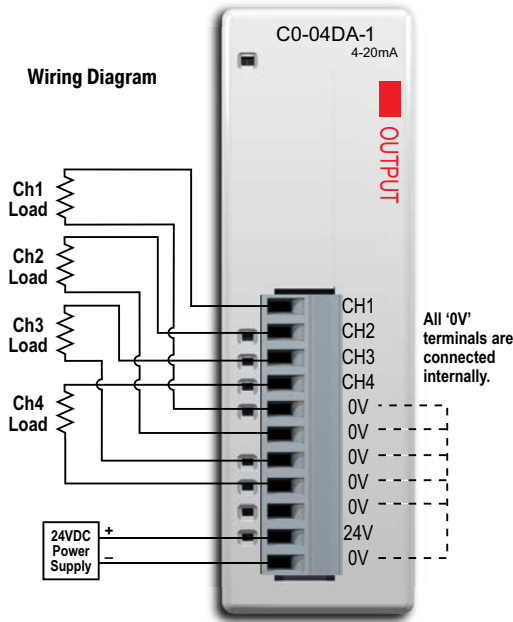

**NOTE:** When using this module you must also use CLICK programming software and PLC firmware version V1.40 or later.

Output Specifications	
Outputs per Module	4
Output Range	4–20 mA (source)
Resolution	12-bit, 3.9 uA per count
Output Type	Current sourcing at 20mA max.
Output Value in Fault Mode	Less than 4mA
Load Impedance	0-600Ω at 24VDC; minimum load: 0Ω 32° to 131°F (0° to 55°C) ambient temp.
Maximum Inductive Load	1mH
Allowed Load Type	Grounded
Maximum Inaccuracy	±1.0% of range
Max. Full Scale Calibration Error (Including Offset)	±0.2% of range maximum
Max. Offset Calibration Error	±0.2% of range maximum
Accuracy vs. Temperature	±75 PPM/°C maximum full scale calibration change (±0.005% of range/°C)
Max. Crosstalk at DC, 50/60 Hz	-72 dB, 1 LSB
Linearity Error (End to End)	±4 LSB max., (±0.1% of full scale)
Output Stability and Repeatability	±2% LSB after 10 minute warmup period typical
Output Ripple	±0.1% of full scale
Output Settling Time	0.3 ms maximum, 5µs min. (full scale range)
All Channel Update Rate	10ms
Max. Continuous Overload	Outputs open circuit protected
Field to Logic Side Isolation	1800VAC applied for 1 second (100% tested)
Type of Output Protection	Electronically limited to 20mA or less
Output Signal at Power Up and Power Down	4mA
External VDC Power Required	145mA
Base Power Required (24VDC)	20mA
Terminal Block Replacement	AutomationDirect p/n C0-8TB
Weight	2.9 oz (82g)

Z/PLink Pre-Wired PLC Connection Cables and Modules for CLICK PLC

ZL-RTB20 20-pin feed-through connector module



11-pin connector cable  
 ZL-C0-CBL11 (0.5 m length)  
 ZL-C0-CBL11-1 (1.0 m length)  
 ZL-C0-CBL11-2 (2.0 m length)



## C0-04DA-2 – 4-Channel Analog Voltage Output Module

4-channel analog voltage output module, 12-bit resolution, range: 0–10 V. External 24VDC power required, removable terminal block included.

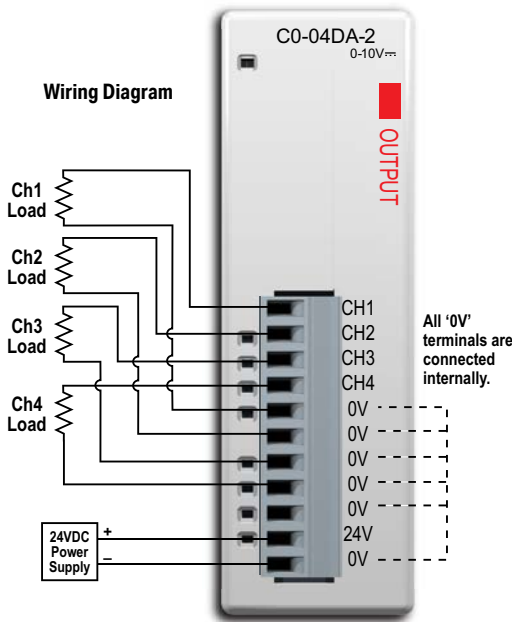

**NOTE:** When using this module you must also use CLICK programming software and PLC firmware version V1.40 or later.

### ZIPLink Pre-Wired PLC Connection Cables and Modules for CLICK PLC

- 11-pin connector cable ZL-C0-CBL11 (0.5 m length)
- ZL-C0-CBL11-1 (1.0 m length)
- ZL-C0-CBL11-2 (2.0 m length)



ZL-RTB20 20-pin feed-through connector module



Output Specifications	
Outputs per Module	4
Output Range	0–10 V
Resolution	12-bit, 2.44 mV per count
Output Type	Voltage sourcing at 10mA max. (One common)
Output Value in Program Mode	Determined by PLC
Output Value in Fault Mode	0 V
Output Impedance	0.2 Ω typical
Load Impedance	>1000Ω
Maximum Capacitive Load	0.01 μF maximum
Allowed Load Type	Grounded
Maximum Inaccuracy	0.5% of range
Max. Full Scale Calibration Error (Not including Offset)	±0.2% of range maximum voltage
Max. Offset Calibration Error	±0.2% of range maximum
Accuracy vs. Temperature	±75 PPM/°C maximum full scale calibration change (±0.0025% of range/°C)
Max. Crosstalk at DC, 50/60 Hz	-72 dB, 1 LSB
Linearity Error (End to End)	±4 LSB max., (±0.1% of full scale); monotonic with no missing codes
Output Stability and Repeatability	±2% LSB after 10 minute warmup period typical
Output Ripple	0.1% of full scale
Output Settling Time	0.3 ms maximum, 5 μs minimum (full scale range)
All Channel Update Rate	10ms
Max. Continuous Overload	Outputs current limited to 40mA typical; continuous overloads on multiple outputs can damage module.
Field to Logic Side Isolation	1800VAC applied for 1 second (100% tested)
Type of Output Protection	0.1 μF transient suppressor
Output Signal at Power Up and Power Down	0 V
External 24VDC Power Required	85mA
Base Power Required (24VDC)	20mA
Terminal Block Replacement	AutomationDirect p/n C0-8TB
Weight	2.9 oz (82g)

## C0-4AD2DA-1 – 4-Channel Analog Current Input and 2-Channel Analog Current Output Module

4-channel analog current sinking input (13-bit resolution) and 2-channel analog current sourcing output (12-bit resolution) module, range: 0–20 mA (inputs), 4–20 mA (outputs). External 24VDC power required, removable terminal block included.

### Wiring Diagram

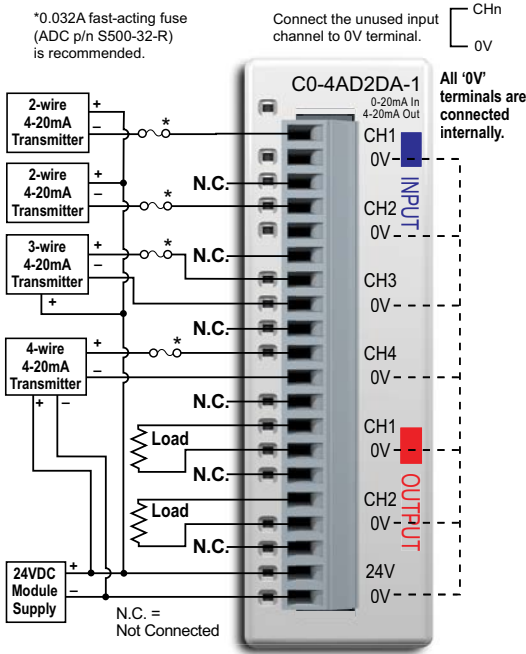

**NOTE:** When using this module you must also use CLICK programming software and PLC firmware version V1.40 or later.

Z/PLink Pre-Wired PLC Connection Cables and Modules for CLICK PLC

- 20-pin connector cable ZL-C0-CBL20 (0.5 m length)
- ZL-C0-CBL20-1 (1.0 m length)
- ZL-C0-CBL20-2 (2.0 m length)

ZL-RTB20 20-pin feed-through connector module



### General Specifications

Field to Logic Side Isolation	1800VAC for 1 sec.
External 24VDC Power Required	75mA
Bus Power Required (24VDC)	25mA
Recommended Fuse (External)	AutomationDirect p/n S500-32-R (0.032 A fuse)
Terminal Block Replacement	AutomationDirect p/n C0-16TB
Weight	3.1 oz (86g)

### Input Specifications

Inputs per Module	4
Input Range	0-20 mA (sink)
Resolution	13-bit, 2.44 uA per count
Input Type	Single ended (one common)
Maximum Continuous Overload	±44 mA
Input Impedance	124Ω, 0.5 W current input
Filter Characteristics	Low pass, -3 dB at 400 Hz
PLC Data Format	13-bit unsigned Integer, range is 0-8191
Sample Duration Time	5 ms
All Channel Update Rate	20 ms (input plus output maximum time)
Open Circuit Detection Time	Zero reading within 20 ms
Conversion Method	Successive approximation
Accuracy vs. Temperature	±75 PPM/°C maximum
Maximum Inaccuracy	0.5% of range (including temperature changes)
Linearity Error (End to End)	±3 count maximum, monotonic with no missing codes
Input Stability and Repeatability	±2 count maximum
Full Scale Calibration Error (Including Offset)	±8 count maximum
Offset Calibration Error	±8 count maximum
Maximum Crosstalk at DC, 50/60 Hz	±2 count maximum

## C0-4AD2DA-1 – 4-Channel Analog Current Input and 2-Channel Analog Current Output Module (continued)

Output Specifications	
Outputs per Module	2
Output Range	4–20 mA (source)
Resolution	12-bit, 3.9 $\mu$ A per count
Output Type	Current sourcing at 20mA max. (One common)
PLC Data Format	12-bit unsigned integer, 0-4095 counts
Output Value in Fault Mode	Less than 4mA
Load Impedance	0–600 $\Omega$ at 24VDC; minimum load: 0 $\Omega$ 32° to 113°F (0° to 45°C); 125 $\Omega$ 113° to 131°F (45° to 55°C) ambient temp.
Maximum Inductive Load	1mH
Allowed Load Type	Grounded
Maximum Inaccuracy	$\pm$ 1% of range
Max. Full Scale Calibration Error (Including Offset)	$\pm$ 0.2% of range maximum
Max. Offset Calibration Error	$\pm$ 0.2% of range maximum
Accuracy vs. Temperature	$\pm$ 50 PPM/°C maximum full scale calibration change ( $\pm$ 0.005% of range/°C)
Max. Crosstalk at DC, 50/60 Hz	-72 dB, 1 LSB
Linearity Error (End to End)	$\pm$ 4 LSB maximum, ( $\pm$ 0.1% of full scale), monotonic with no missing codes
Output Stability and Repeatability	$\pm$ 2% LSB after 10 minute warmup period typical
Output Ripple	$\pm$ 0.1% of full scale
Output Settling Time	0.2 ms maximum, 5 $\mu$ s min. (full scale range)
All Channel Update Rate	20ms
Max. Continuous Overload	Outputs open circuit protected
Type of Output Protection	Electronically limited to 20mA or less
Output Signal at Power Up or Power Down	4mA

## C0-4AD2DA-2 – 4-Channel Analog Voltage Input and 2-Channel Analog Voltage Output Module

4-channel analog voltage input (13-bit resolution) and 2-channel analog voltage output (12-bit resolution) module, range: 0-10V. External 24VDC power required, removable terminal block included.

### Wiring Diagram

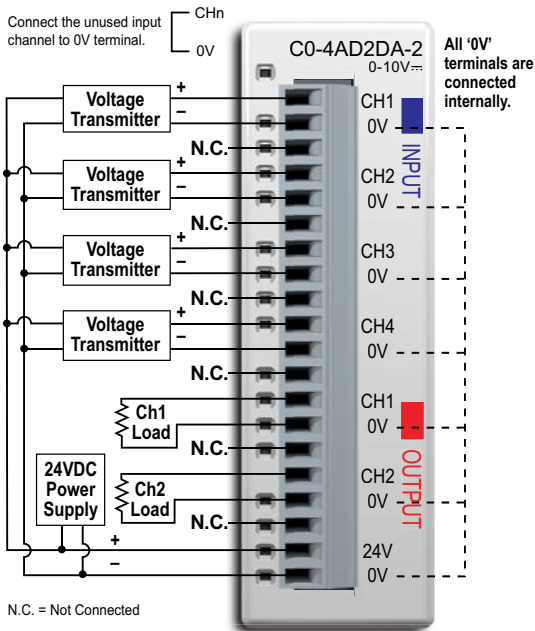

**NOTE:** When using this module you must also use CLICK programming software and PLC firmware version V1.40 or later.

### ZIPLink Pre-Wired PLC Connection Cables and Modules for CLICK PLC

- 20-pin connector cable
- ZL-C0-CBL20 (0.5 m length)
- ZL-C0-CBL20-1 (1.0 m length)
- ZL-C0-CBL20-2 (2.0 m length)



ZL-RTB20 20-pin feed-through connector module

### General Specifications

<b>Field to Logic Side Isolation</b>	1800VAC for 1 sec.
<b>External 24VDC Power Required</b>	65mA
<b>Base Power Required (24VDC)</b>	20mA
<b>Terminal Block Replacement</b>	AutomationDirect p/n C0-16TB
<b>Weight</b>	3.1 oz (86g)

### Input Specifications

<b>Inputs per Module</b>	4
<b>Input Range</b>	0-10 V
<b>Resolution</b>	13-bit, 1.22 mV per count
<b>Input Type</b>	Single ended (one common)
<b>Maximum Continuous Overload</b>	±100VDC
<b>Input Impedance</b>	>150kΩ
<b>Filter Characteristics</b>	Low pass, -3dB at 500Hz
<b>Sample Duration Time</b>	5ms
<b>All Channel Update Rate</b>	20ms
<b>Open Circuit Detection Time</b>	Zero reading within 100ms
<b>Conversion Method</b>	Successive approximation
<b>Accuracy vs. Temperature</b>	±75 PPM/°C maximum
<b>Maximum Inaccuracy</b>	0.5% of range (including temperature changes)
<b>Linearity Error (End to End)</b>	±3 count maximum, monotonic with no missing codes
<b>Input Stability and Repeatability</b>	±2 count maximum
<b>Full Scale Calibration Error (including Offset)</b>	±8 count maximum
<b>Offset Calibration Error</b>	±8 count maximum
<b>Maximum Crosstalk at DC, 50/60 Hz</b>	±2 count maximum

## C0-4AD2DA-2 – 4-Channel Analog Voltage Input and 2-Channel Analog Voltage Output Module (continued)

Output Specifications	
Outputs per Module	2
Output Range	0–10 V
Resolution	12-bit, 2.44 mV per count
Output Type	Voltage sourcing at 10mA max. (One common)
Output Value in Program Mode	Determined by PLC
Output Value in Fault Mode	0V
Output Impedance	0.2 $\Omega$ typical
Load Impedance	>1000 $\Omega$
Maximum Capacitive Load	0.01 $\mu$ F maximum
Allowed Load Type	Grounded
Maximum Inaccuracy	1% of range
Max. Full Scale Calibration Error (Not including Offset)	$\pm 0.2\%$ of range maximum voltage
Max. Offset Calibration Error	$\pm 0.2\%$ of range maximum
Accuracy vs. Temperature	$\pm 75$ PPM/ $^{\circ}$ C maximum full scale calibration change ( $\pm 0.0025\%$ of range/ $^{\circ}$ C)
Max. Crosstalk at DC, 50/60 Hz	-72dB, 1 LSB
Linearity Error (End to End)	$\pm 4$ LSB maximum, ( $\pm 0.1\%$ of full scale); monotonic with no missing codes
Output Stability and Repeatability	$\pm 2\%$ LSB after 10 minute warmup period typical
Output Ripple	0.5% of full scale
Output Settling Time	0.3 ms maximum, 5 $\mu$ s minimum (full scale range)
All Channel Update Rate	20ms
Max. Continuous Overload	Outputs current limited to 40mA typical; continuous overloads on multiple outputs can damage module.
Type of Output Protection	0.1 $\mu$ F transient suppressor
Output Signal at Power Up or Power Down	0V

# Power Supply Specifications

## C0-00AC Power Supply

Limited auxiliary AC power supply allows you to power the CLICK PLC with 100-240 VAC supply power. The 0.5 A DC power supply is capable of controlling the PLC plus a limited configuration based on the power budget of each I/O module. The C0-00AC is a low-cost solution for applications requiring only minimal I/O and power consumption. This power supply will not support a fully-populated CLICK PLC system with all possible I/O module combinations.



C0-00AC Power Supply Specification	
<b>Input Voltage Range</b>	85-264 VAC
<b>Input Frequency</b>	47-63 Hz.
<b>Input Current (typical)</b>	0.3 A @ 100 VAC, 0.2 A @ 200VAC
<b>Inrush Current</b>	30A
<b>Output Voltage Range</b>	23-25 VDC
<b>Output Current</b>	0.5 A
<b>Over Current Protection</b>	@ 0.65 A (automatic recovery)
<b>Weight</b>	5.3 oz (150g)

## C0-01AC Power Supply

No-limit auxiliary AC power supply allows you to power the CLICK PLC with 100-240 VAC supply power. The 1.3 A DC power supply is capable of supporting a fully-populated CLICK PLC system with all possible I/O module combinations with no concerns of exceeding the power budget.



C0-01AC Power Supply Specification	
<b>Input Voltage Range</b>	85-264 VAC
<b>Input Frequency</b>	47-63 Hz.
<b>Input Current (typical)</b>	0.9 A @ 100VAC, 0.6 A @ 200VAC
<b>Inrush Current</b>	30A
<b>Output Voltage Range</b>	23-25 VDC
<b>Output Current</b>	1.3 A
<b>Over Current Protection</b>	@ 1.6 A (automatic recovery)
<b>Weight</b>	6.0 oz (170g)

## PSP24-DC12-1 DC-DC Converter

With this DC-DC converter you can operate the CLICK PLC with 12VDC input power.



PSP24-DC12-1 DC-DC Converter Specifications	
<b>Input Voltage Range</b>	9.5-18 VDC
<b>Input Power (no load)</b>	1.0 W max.
<b>Startup Voltage</b>	8.4 VDC
<b>Undervoltage Shutdown</b>	7.6 VDC
<b>Output Voltage Range</b>	24-28 VDC (adjustable)
<b>Output Current</b>	1.0 A
<b>Short Circuit Protection</b>	Current limited at 110% typical
<b>Weight</b>	7.5 oz (213g)

## Accessories

### C0-USER-M – CLICK PLC Hardware Users Manual



Manual covers all CLICK PLC & I/O Module installation & wiring, specifications, error codes & trouble shooting guide. Sold separately from hardware.

The CLICK PLC Hardware User Manual can be downloaded free at the AutomationDirect Web site or purchased from the AutomationDirect online Web store, [www.automationdirect.com](http://www.automationdirect.com)

### C0-PGMSW – CLICK PLC Programming Software USB



CLICK PLC programming software Ladder Logic Editor for Windows PCs, includes the manual as a pdf file. Free download available from AutomationDirect online Web store: [www.automationdirect.com](http://www.automationdirect.com). Alternatively the programming software USB may be purchased and shipped from the AutomationDirect online Web store: [www.automationdirect.com](http://www.automationdirect.com)

### EA-MG-PGM-CBL – PC to Panel Programming Cable Assembly for C-more Micro-Graphic Panels and/or PC to CLICK PLCs.



6-ft. cable assembly to connect personal computer to any C-more Micro-Graphic panel or CLICK PLC for setup and programming. (Note: This cable assembly uses the PC's USB port and converts the signals to serial transmissions. The USB port supplies 5VDC to the Micro-Graphic panel for configuration operations). Assembly includes standard USB A-type connector to B-type connector cable, custom converter, and an RS232C cable with RJ12 modular connector on each end.



**NOTE:** If your PC has a USB port but does not have a serial port, you must use programming cable EA-MG-PGM-CBL.

### D2-DSCBL – PC Programming Cable for CLICK and DirectLOGIC PLCs



12ft (3.66 m) RS232 shielded PC programming cable for CLICK, DL05, DL06, DL105, DL205, D3-350, and D4-450 CPUs. 9-pin D-shell female connector to an RJ12 6P6C connector.

### Cat5e – PC Programming Ethernet Cable for CLICK PLCs



3ft–50ft Cat5e STP Ethernet Patch Cable for PC programming of CLICK PLCs; RJ45 connector. Straight or Cross-over cable can be used.

### Accessories (cont'd)

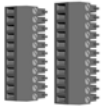

#### **C0-8TB – Spare 8 Point I/O Terminal Block**

Replacement terminal block for the 8 point I/O modules. Sold in packs of 2.

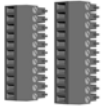

#### **C0-8TB-1 – Spare 8 Point I/O Terminal Block**

Replacement terminal block for the 8 point relay I/O modules. Sold in packs of 2.

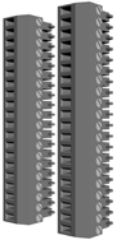

#### **C0-16TB – Spare 16 Point I/O Terminal Block**

Replacement terminal block for the 16 point I/O modules & PLC built-in I/O. Sold in packs of 2.



#### **C0-3TB - Spare 3-Pole Terminal Block**

Replacement 3-pole terminal block for the 3-wire, RS485 communications port on the CLICK Standard and Analog PLCs. Sold in packs of 2.

#### **C0-4TB – Spare 24VDC Power Terminal Block**

Replacement terminal block for the 24VDC supply power to the PLC. Sold in packs of 2.



#### **D2-BAT-1 – Battery**

Replacement battery for Standard, Analog, and Ethernet PLC units.

### ZIPLink Wiring Systems

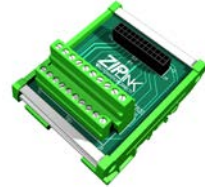

### C-more and C-more Micro-Graphic Operator Interfaces



### DN-WS – Wire Stripper



### TW-SD-MSL-2 – Insulated Slotted Screwdriver 0.4 x 2.5 x 80 mm



### DN-EB35MN – DINnectors End Bracket



# INSTALLATION AND WIRING

---



# CHAPTER 3

## In This Chapter...

Safety Guidelines.....	3-2
Introduction to the CLICK PLC Mechanical Design .....	3-5
Mounting Guidelines .....	3-11
Installing the CLICK PLC .....	3-17
Wiring Guidelines .....	3-19
I/O Wiring Checklist .....	3-26
System Wiring Strategies .....	3-27
Analog I/O Configuration.....	3-38
High-Speed Input Configuration .....	3-45

# Safety Guidelines



---

**NOTE:** Products with CE marks perform their required functions safely and adhere to relevant standards as specified by CE directives, provided they are used according to their intended purpose and that the instructions in this manual are followed. The protection provided by the equipment may be impaired if this equipment is used in a manner not specified in this manual. A listing of our international affiliates is available on our Web site at <http://www.automationdirect.com>.

---



---

**WARNING:** Providing a safe operating environment for personnel and equipment is your responsibility and should be your primary goal during system planning and installation. Automation systems can fail and may result in situations that can cause serious injury to personnel or damage to equipment. Do not rely on the automation system alone to provide a safe operating environment. You should use external electromechanical devices, such as relays or limit switches, that are independent of the PLC application to provide protection for any part of the system that may cause personal injury or damage. Every automation application is different, so there may be special requirements for your particular application. Make sure you follow all national, state, and local government requirements for the proper installation and use of your equipment.

---

## Plan for Safety

The best way to provide a safe operating environment is to make personnel and equipment safety part of the planning process. You should examine every aspect of the system to determine which areas are critical to operator or machine safety. If you are not familiar with PLC system installation practices, or your company does not have established installation guidelines, you should obtain additional information from the following sources.

- NEMA — The National Electrical Manufacturers Association, located in Washington, D.C., publishes many different documents that discuss standards for industrial control systems. You can order these publications directly from NEMA. Some of these include:
  - ICS 1, General Standards for Industrial Control and Systems
  - ICS 3, Industrial Systems
  - ICS 6, Enclosures for Industrial Control Systems
- NEC — The National Electrical Code provides regulations concerning the installation and use of various types of electrical equipment. Copies of the NEC Handbook can often be obtained from your local electrical equipment distributor or your local library.
- Local and State Agencies — many local governments and state governments have additional requirements above and beyond those described in the NEC Handbook. Check with your local Electrical Inspector or Fire Marshall office for information.

## Three Levels of Protection



**WARNING:** The control program must not be the only form of protection for any problems that may result in a risk of personal injury or equipment damage.

The publications mentioned provide many ideas and requirements for system safety. At a minimum, you should follow these regulations. Also, you should use the following techniques, which provide three levels of system control.

1. Orderly system shutdown sequence in the PLC control program
2. Mechanical disconnect for output module power
3. Emergency stop switch for disconnecting system power

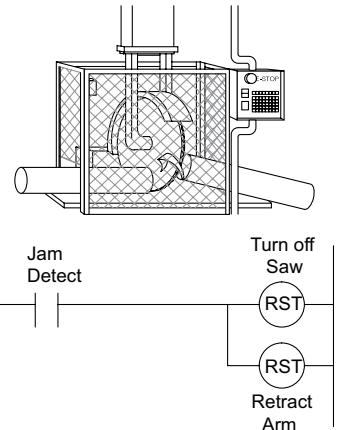

## Orderly System Shutdown

The first level of fault detection is ideally the PLC control program, which can identify machine problems. These types of problems are usually things such as jammed parts, etc., that do not pose a risk of personal injury or equipment damage. However, respective shutdown sequences should be performed.

## System Power Disconnect

You should also use electromechanical devices, such as master control relays and/or limit switches, to prevent accidental equipment startup at an unexpected time. These devices should be installed in a manner that will prevent any machine operations from occurring.

For example, if the machine in the illustration has a jammed part, the PLC control program can turn off the saw blade and retract the arbor. If the operator must open the guard to remove the part, you should also include a bypass switch that disconnects all system power any time the guard is opened.

### Emergency Stop Circuits

Emergency stop (E-Stop) circuits are a critical part of automation safety. For each machine controlled by a PLC, provide an emergency stop device that is wired outside the PLC and easily accessed by the machine operator.

E-stop devices are commonly wired through a master control relay (MCR) or a safety control relay (SCR) that will remove power from the PLC I/O system in an emergency.

MCRs and SCRs provide a convenient means for removing power from the I/O system during an emergency situation. By de-energizing an MCR (or SCR) coil, power to the input (optional) and output devices is removed. This event occurs when any emergency stop switch opens. However, the PLC continues to receive power and operate even though all its inputs and outputs are disabled.

The MCR circuit could be extended by placing a PLC fault relay (closed during normal PLC operation) in series with any other emergency stop conditions. This would cause the MCR circuit to drop the PLC I/O power in case of a PLC failure (memory error, I/O communications error, etc.).

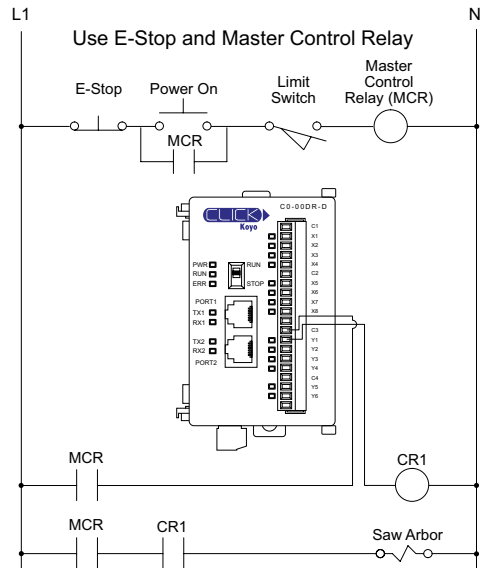
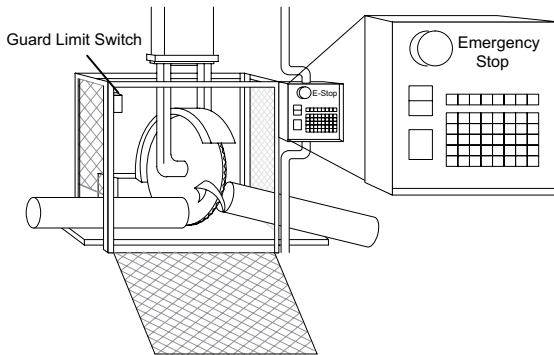

**WARNING:** For some applications, field device power may still be present on the terminal block even though the PLC is turned off. To minimize the risk of electrical shock, remove all field device power before you expose or remove PLC wiring. The connector is designed for easy removal by hand.

# Introduction to the CLICK PLC Mechanical Design

## CLICK PLC Units

All CLICK PLCs are similar in appearance. Please see the diagrams below to familiarize yourself with the PLC features. The main components located on the front of the PLC are a removable 20-pin I/O connector, Run/Stop switch, communications ports and LED status indicators. A removable 4-pin 24VDC input power connector is located on the bottom of the PLC. The I/O module extension port is located on the right side of the PLC case. See Mounting Guidelines in this chapter for module dimensions and Chapter 2 for CLICK PLC specifications.

## Component Locations on Basic and Standard PLC Units

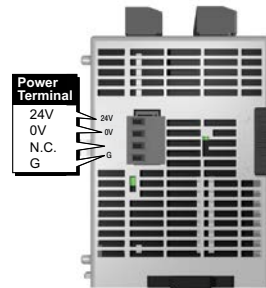
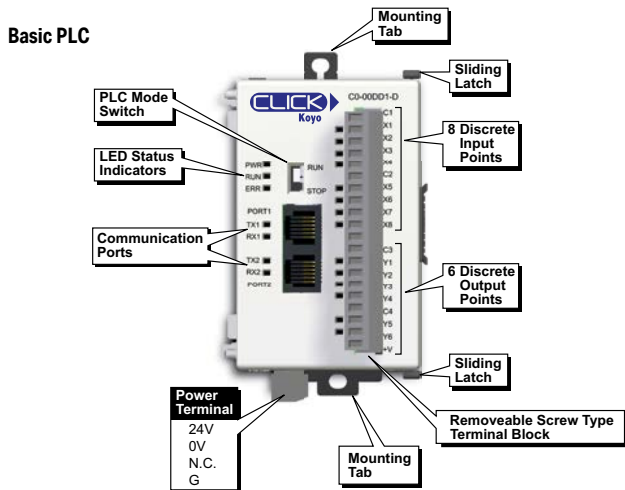

Bottom view same for all PLC's

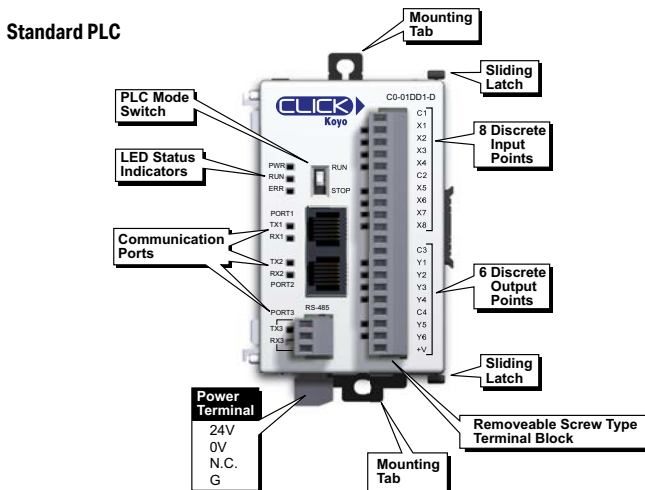

## Component Locations on Analog PLC Units

### Analog PLC

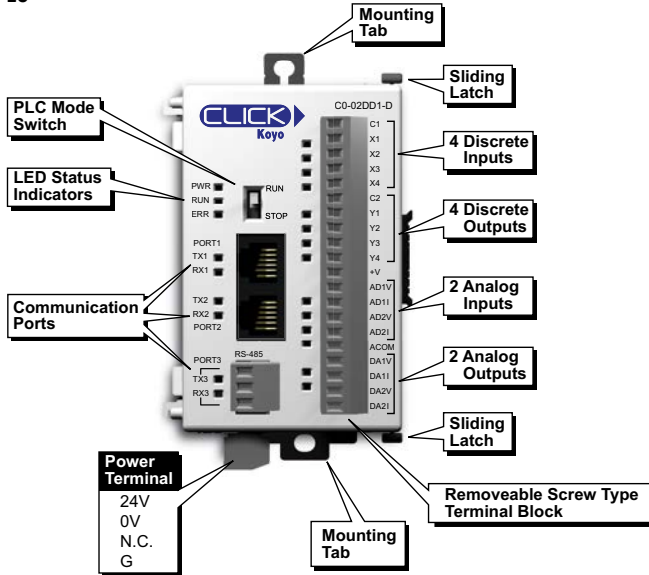

### Ethernet Basic PLC

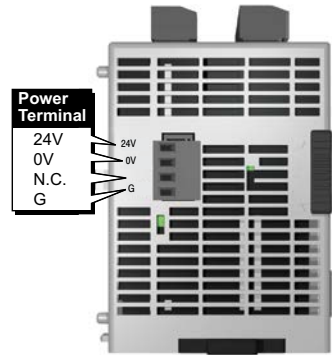
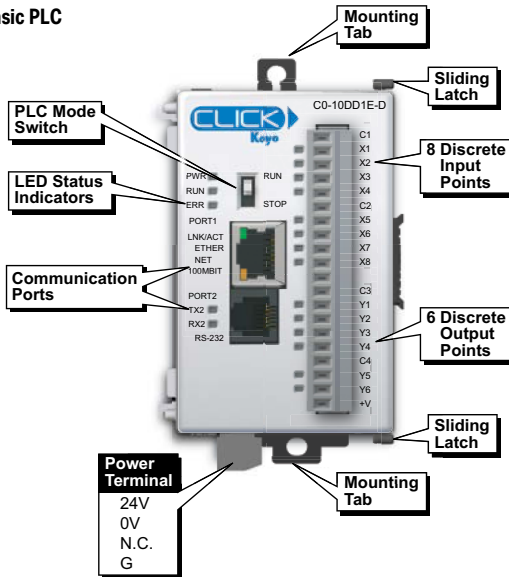

Bottom view same for all PLC's

## Component Locations on Ethernet PLC Units

### Ethernet Standard PLC

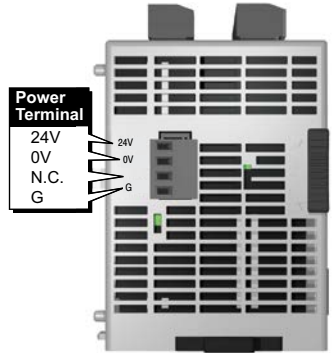
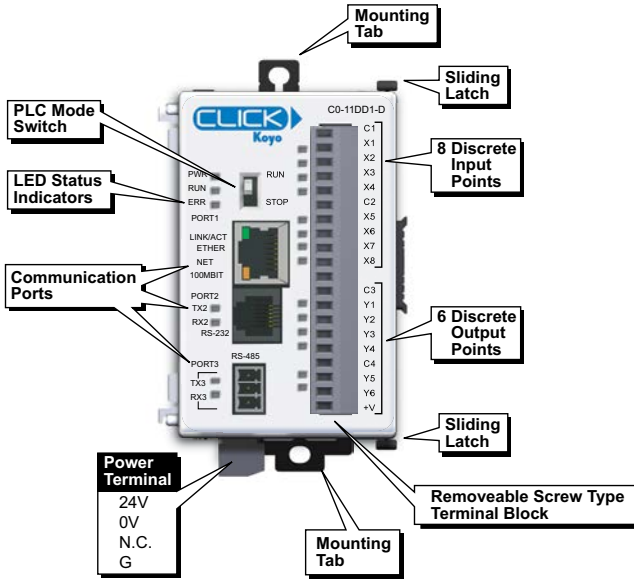

Bottom view same for all PLC's

### Ethernet Analog PLC

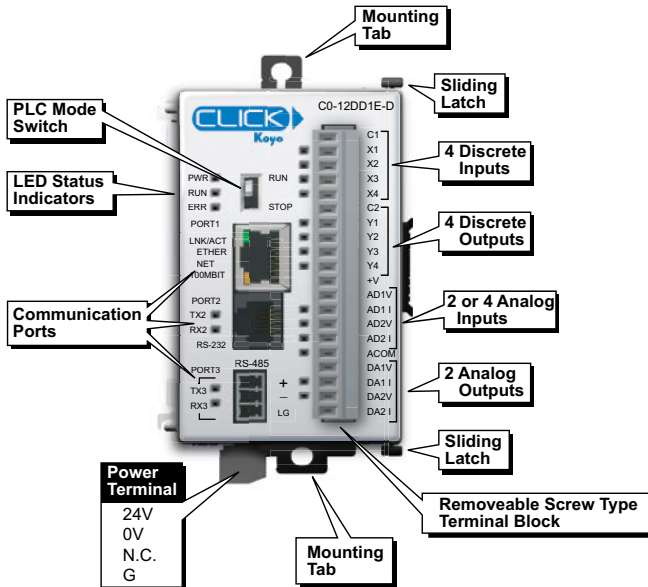

### CLICK I/O Modules

Several different types of input and output modules are available for the CLICK PLC system. Please see the diagrams below to familiarize yourself with the I/O module features.

Each I/O module is identified as an Input or Output module on its front panel using the color coding scheme listed below. Up to eight I/O option modules can be connected to a CLICK PLC. See Mounting Guidelines in this chapter for module dimensions and Chapter 2 for CLICK I/O module specifications.

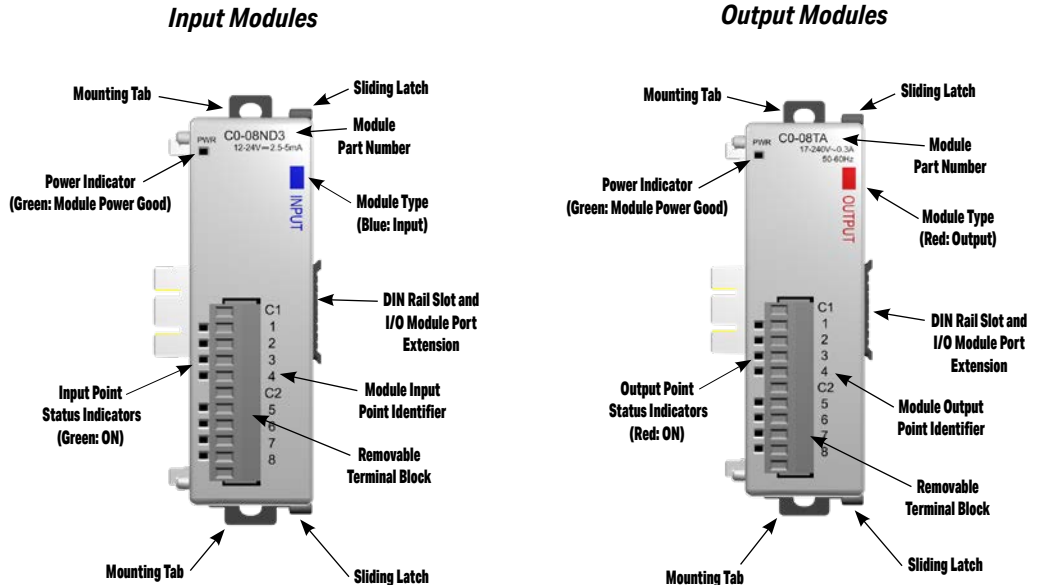

## CLICK Power Supplies

All CLICK PLCs require 24VDC input power from either a CLICK power supply or other suitable external power supply. Two models of CLICK power supplies are available to supply power to the PLC and I/O modules.

- C0-00AC - 0.5 A @ 24VDC output
- C0-01AC - 1.3 A @ 24VDC output

Select a power supply based on the power requirements of your system components. See Mounting Guidelines in this chapter for module dimensions and Chapter 2 for CLICK power supply specifications.

Power wires must be connected from the output terminals on the front of the power supply to the input power connector on the bottom of the CLICK PLC (There is no internal 24VDC power bus to the PLC.) See Mounting Guidelines for additional wiring information.

Only a single CLICK power supply can be attached directly to a CLICK PLC system. If multiple CLICK power supplies are used, or if other type of power supplies are used, mount them separately from the PLC. For example, the PSP24-DC12-1 DC-DC converter shown below must be mounted separately from the PLC.

### ***C0-00AC and C0-01AC Power Supplies Component Locations***

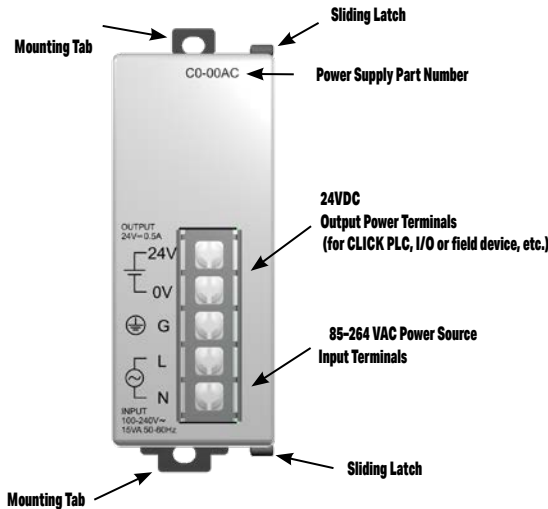

The PSP24-DC12-1 DC-DC converter must be mounted separately from the PLC.

### Battery Backup (Standard, Analog and Ethernet PLC Units)

All of the CLICK PLC units have a super capacitor to maintain back up data in SRAM. However, the backup period by the super capacitor depends on the CLICK PLC unit type you use.

CLICK PLC Unit	Backup Period by the Super Capacitor
Basic PLC units Standard PLC units Analog PLC units	7 days
Ethernet Basic PLC units Ethernet Standard PLC units Ethernet Analog PLC units	1 hour

If you need the CLICK PLC unit to maintain data in the SRAM for longer than the above period after the power is shut off, you must install a battery in the CLICK PLC unit.



**NOTE:** CLICK Basic PLC units do not have the battery backup feature.

Use battery part number D2-BAT-1 (not included with the PLC unit; order battery separately). Typical battery life is 3 years, which includes PLC runtime and normal shutdown periods.



**NOTE:** Please power off the PLC while installing and/or changing the battery.

To install or replace the D2-BAT-1 battery:

1. Press the retaining clip on the battery door and swing the battery door open.
2. Install the battery into the coin-type slot with the +, or flat, side out.
3. Close the battery door so that it locks securely.
4. Make a note of the date the battery was installed.

The battery backup is now available.



**WARNING:** Do not attempt to recharge the battery or dispose of it by fire. The battery may explode or release hazardous materials.



**TIP:** The CLICK PLC has a feature that indicates the pre-scheduled battery replacement date has passed. In the CLICK programming software, go to the pull-down menu: Setup > Battery backup Setup.

## Mounting Guidelines

### Environmental Specifications

The CLICK family of PLC products should be stored, installed, and used within their range of environmental specifications, such as storage temperature, operating temperature, humidity, environmental air, vibration, shock, and noise immunity. Certain output module circuit types may have derating curves depending on the ambient temperature and the number of outputs ON. Refer to the I/O module specifications in Chapter 2: *Specifications* for CLICK PLC environmental specifications and I/O module derating curves.

### Agency Approvals

In addition to the panel layout guidelines, other specifications can affect the definition and installation of a PLC system. Always consider the following:

- Environmental Specifications
- Power Requirements
- Agency Approvals
- Enclosure Selection and Component Dimensions

### CLICK Unit Dimensions

The following diagrams illustrate the dimensions of the CLICK power supply, CLICK PLC, and I/O modules. The CLICK PLC system is designed to be mounted on standard 35mm DIN rail, or it can be surface mounted. See the following pages for installations and mounting information, including page 3-17 for DIN rail and surface-mounting instructions.

#### Power Supply

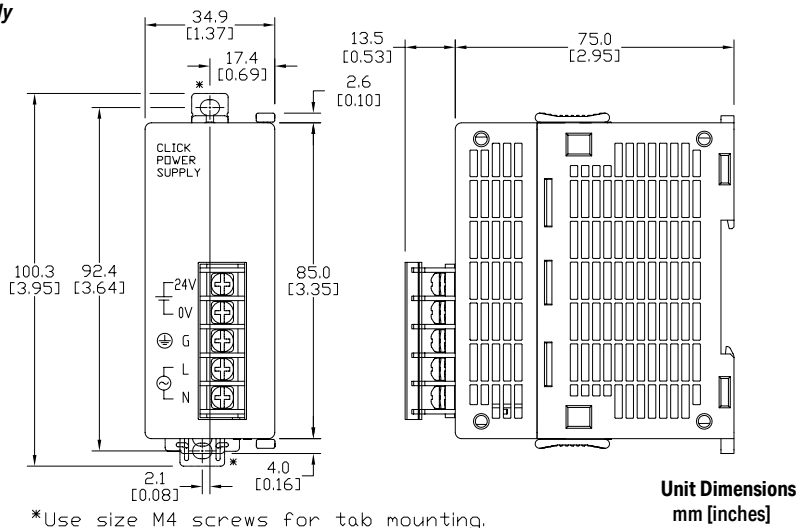

**NOTE:** The dimensions for the C0-00AC and C0-01AC power supplies are the same.

## PLC Unit

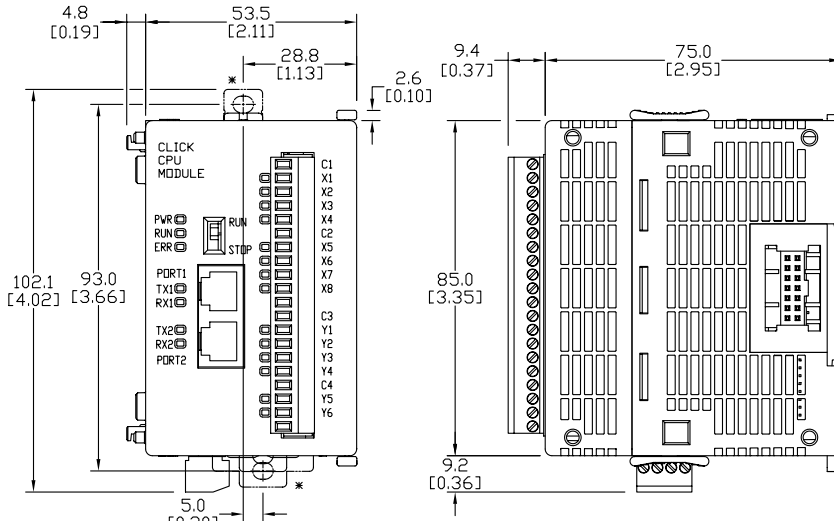

\*Use size M4 screws for tab mounting.

## I/O Module

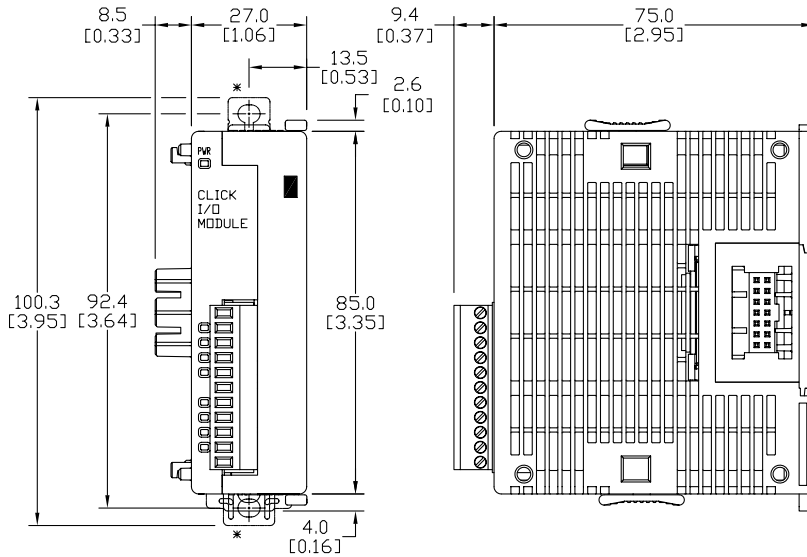

\*Use size M4 screws for tab mounting.

**Unit Dimensions**  
mm [inches]

**Stackable C0-04POT Module**

**Unit Dimensions**  
mm [inches]

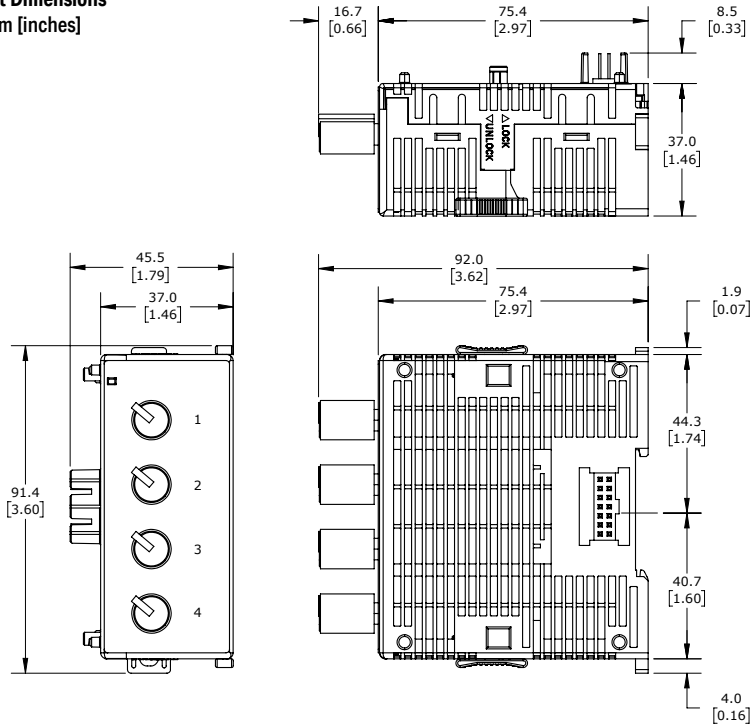

## PLC Unit System

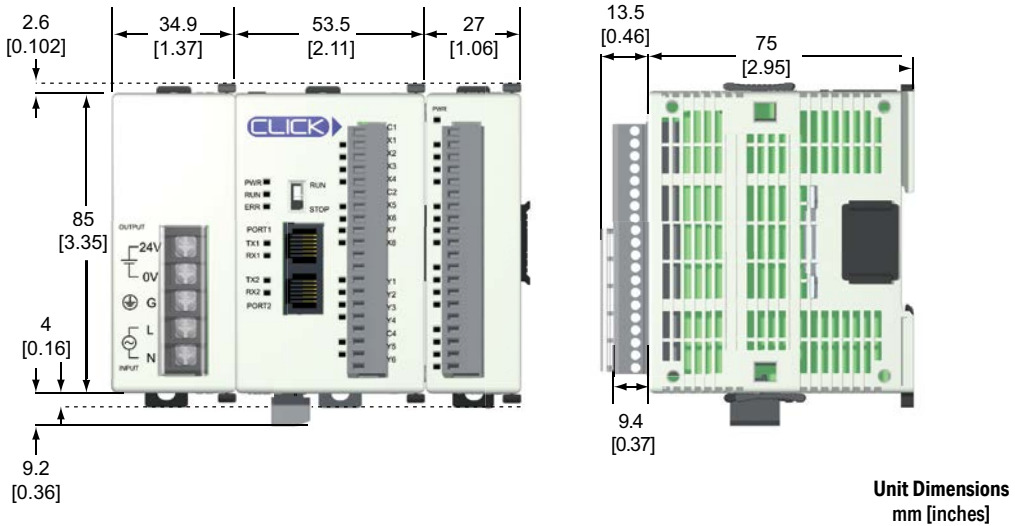

### Maximum system: Power Supply + PLC + eight I/O modules.

Follow the installation guidelines to allow for proper spacing from other components within an enclosure.

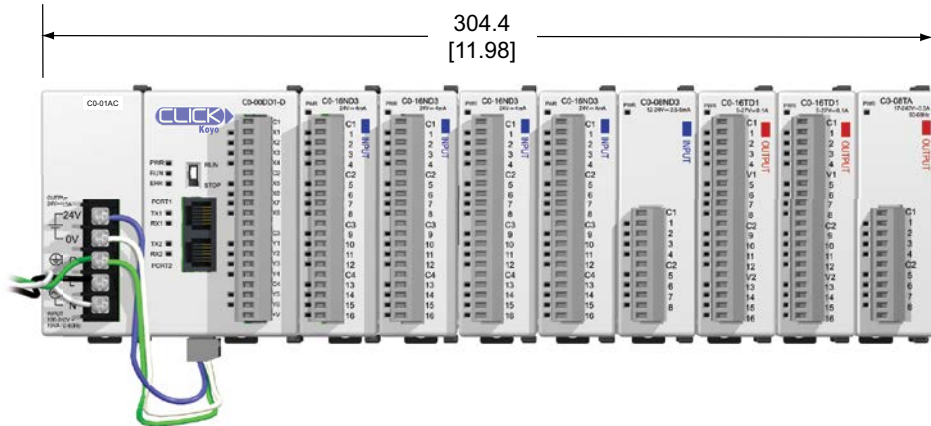

## Enclosures

Your selection of a proper enclosure is important to ensure safe and proper operation of your CLICK PLC system. Control applications vary and yours may require additional considerations. At a minimum your enclosure should include:

- Conformance to electrical standards
- Protection from the elements in an industrial environment
- Common ground reference
- Maintenance of specified ambient temperature
- Access to equipment
- Security or restricted access
- Sufficient space for proper installation and maintenance of equipment

## Panel Layout and Clearances

1. Mount the CLICK PLC unit (system) horizontally as shown below to provide proper ventilation. Do not mount the CLICK PLC units upside down, on a horizontal surface or in a vertical arrangement. If you place more than one unit in a cabinet, there must be a minimum of 7.2" (183mm) between the units.

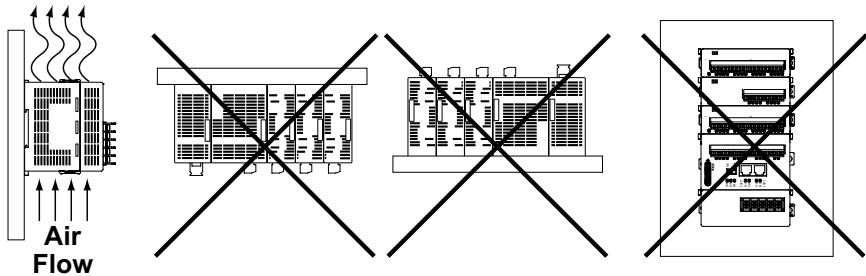

2. Provide a minimum clearance of 2" (50mm) between the unit and all sides of the cabinet.  
*NOTE:* Remember to allow clearance for any operator panels or other items mounted directly in front of the unit in the door.
3. There should also be at least 3" (78mm) of clearance between the unit and any wiring ducts that run parallel to the terminals.
4. The ground terminal on the CLICK PLC must be connected to a single point ground. Use copper stranded wire to achieve a low impedance. Copper eye lugs should be crimped and soldered to the ends of the stranded wire to ensure good surface contact.
5. There must be a single point ground (i.e. copper bus bar) for all devices in the panel requiring an earth ground return. The single point of ground must be connected to the panel ground termination. The panel ground termination must be connected to ground. Minimum wire sizes, color coding, and general safety practices should comply with appropriate electrical codes and standards for your area.

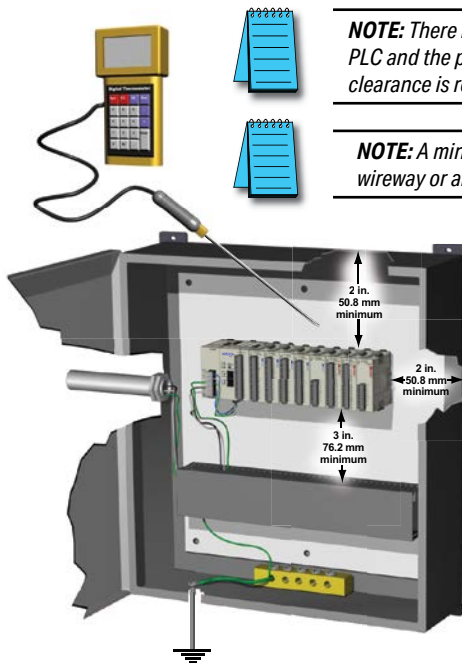

**NOTE:** There is a minimum clearance requirement of 2" (51mm) between the **CLICK PLC** and the panel door or any devices mounted in the panel door. The same clearance is required between the PLC and surrounding enclosure.

**NOTE:** A minimum clearance of 3" (76mm) is required between the PLC and a wireway or any heat producing device.

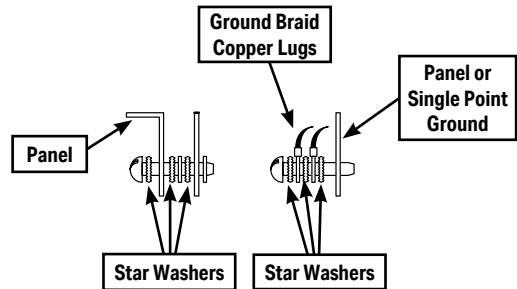

6. A good common ground reference (Earth ground) is essential for proper operation of the CLICK PLC. One side of all control and power circuits and the ground lead on flexible shielded cable must be properly connected to Earth ground. There are several methods of providing an adequate common ground reference, including:
  - a) Installing a ground rod as close to the panel as possible
  - b) Connection to incoming power system ground
7. Evaluate any installations where the ambient temperature may approach the lower or upper limits of the specifications. If you suspect the ambient temperature will not be within the operating specification for the CLICK PLC system, measures such as installing a cooling/heating source must be taken to get the ambient temperature within the range of specifications.
8. CLICK PLC systems are modular and can be powered by any suitable 24VDC power supply. The optional CLICK power supply is designed to attach to the left side of the CLICK PLC case. CLICK power supplies accept 85-264 VAC and produce nominal 24VDC to power the CLICK PLC and I/O modules. Powerline filters are recommended for protecting the CLICK PLC from power surges and EMI/RFI noise. The AutomationDirect Powerline Filter, for use with 120VAC and 240VAC, 1-5 Amps, is an excellent choice (locate at [www.automationdirect.com](http://www.automationdirect.com)), however, you can use a filter of your choice. The filter units install easily between the AC power source and the PLC.

## Installing the CLICK PLC

### Connecting the Modules Together

CLICK PLCs and I/O modules connect together using the Extension Ports that are located on the side panels of the modules. The modules secure together by sliding LOCK/UNLOCK latch tabs located on the top and bottom panels of the modules. A PLC backplane or base is not required.

When connecting an I/O module to the PLC, first remove the Extension Port covers, slide the latches forward (unlock), align the module pins, and press the I/O module onto the right side of the PLC's right side. Slide the latches backward to lock the modules together.



**NOTE:** If you are using other components in your system, make sure you refer to the appropriate manual to determine how those units can affect mounting dimensions.

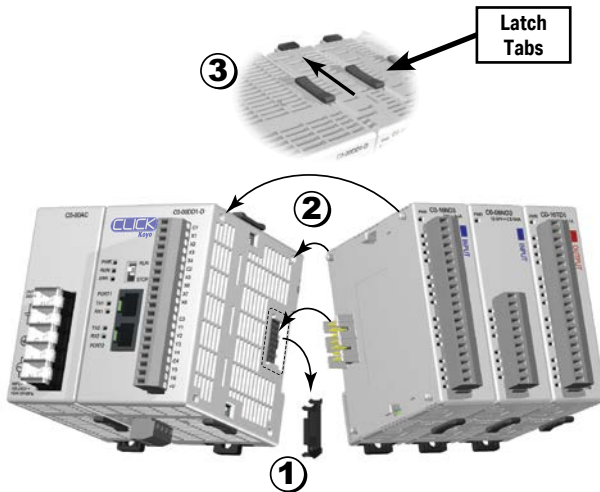

- 1) Remove extension port covers and slide latch tabs forward.
- 2) Align the module pins and connection plug, and press the I/O module onto the right side of the PLC.
- 3) Slide the latch tabs backward to lock the modules together.

### Mounting CLICK PLC System on DIN Rail

CLICK PLCs can be secured to a panel by using mounting rails. We recommend rails that conform to DIN EN standard 50 022. They are approximately 35mm high, with a depth of 7mm. If you mount the CLICK PLC on a rail, consider using end brackets on each side of the PLC. The end bracket helps keep the PLC from sliding horizontally along the rail, reducing the possibility of accidentally pulling the wiring loose. On the bottom of the PLC is a small retaining clip. To secure the PLC to a DIN rail, place it onto the rail and gently push up on the clip to lock it onto the rail. To remove the PLC, pull down on the retaining clip, lift up on the PLC slightly, then pull it away from the rail.

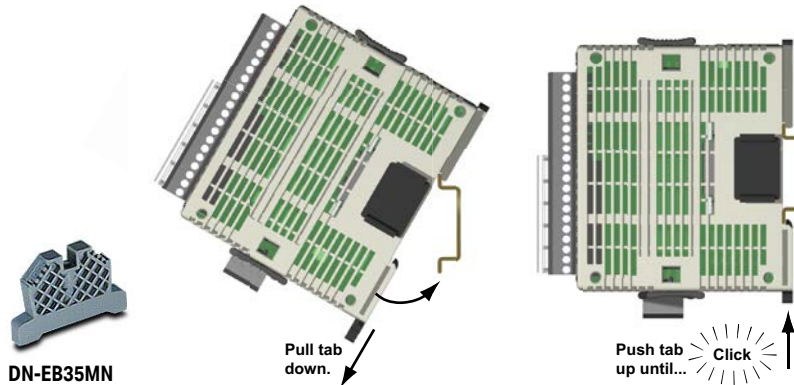

**NOTE:** When mounting on DIN rail, using DINnectors end brackets at both ends is recommended (part number DN-EB35MN).

### Optional Mounting Method

The CLICK PLC system can be secured to the equipment panel or desired location using the mounting tabs located on the back panel of the PLC, I/O modules and power supplies. Extend the upper and lower retaining clips to the full out position. Mount using M4 screws in the center hole of the tabs.



## Wiring Guidelines

### Power Input Wiring to Click Power Supply

Connect the AC power source input wiring to the CLICK power supply (the CLICK power supply voltage and current requirements are listed in chapter 2). If you are not using a CLICK power supply, be sure that it meets CLICK PLC requirements.

Do not apply power at this time. Observe all precautions stated earlier in this manual.



**WARNING:** Once the power wiring is connected, secure the terminal block cover in the closed position. When the cover is open there is a risk of electrical shock if you accidentally touch the connection terminals or power wiring.

### Power Input Wiring to CLICK PLC

Connect the 24VDC power source input wiring to the 4-pin 24VDC input connector located on the bottom panel of the CLICK PLC. Do not apply power at this time. Observe all precautions stated earlier in this manual.

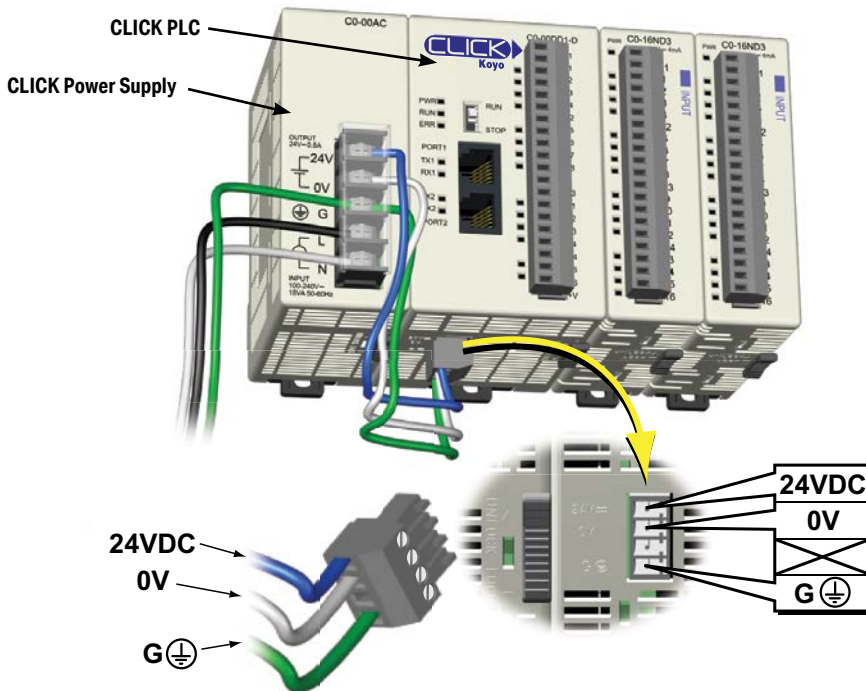

### Fuse Protection

#### Fuse Protection for PLC Input Power

External circuit protection is needed to ensure the safety of service personnel and the safe operation of the equipment itself. To meet UL/CUL specifications, the input power must be fused. Fuse the AC side of the power supply that provides the 24VDC power to the CLICK PLC.

When operating the power supply from a 110/120 VAC system with a grounded neutral, it is only necessary to fuse the line (L) lead; it is not necessary to fuse the grounded neutral (N) lead. Select the fuse size based on the input current draw of the power supply. Refer to Chapter 2 of this manual for specifications of CLICK power supplies.

#### Fuse Protection for I/O Module Circuits

Input and Output circuits on CLICK PLCs do not have internal fuses. In order to protect your PLC, we suggest you add external fuses to your I/O wiring. A fast-blow fuse, with a lower current rating than the I/O bank's common current rating can be wired to each common. Or, a fuse with a rating of slightly less than the maximum current per output point can be added to each output. Refer to the I/O module specifications in Chapter 2 to find the maximum current per output point or per output common. Adding the external fuse does not guarantee the prevention of PLC damage, but it will provide added protection.



**WARNING: The discrete inputs and outputs will be damaged if the signal exceeds the rated voltage.**



### Planning the I/O Wiring Routes

The following guidelines provide general information on how to wire the I/O connections to CLICK PLCs. For additional information about wiring a particular I/O type refer to the corresponding information in this chapter.

1. Each terminal connection of the CLICK PLC can accept one 16AWG wire or two 18AWG size wires. Do not exceed this recommended capacity. Refer to Chapter 2 *Specifications* for more detailed specifications of the terminal blocks.
2. Always use a continuous length of wire. Do not splice wires to attain a needed length.
3. Use the shortest possible wire length.
4. Use wire trays for routing where possible.
5. Avoid running lower voltage wires near higher voltage wiring.
6. Avoid running input wiring close to output wiring where possible.
7. To minimize voltage drops when wires must run a long distance, consider using multiple wires for the return line.
8. Avoid running DC wiring in close proximity to AC wiring where possible.
9. Avoid creating sharp bends in the wires.
10. Install the recommended powerline filter to reduce power surges and EMI/RFI noise.

### Wiring I/O Modules

There are three sizes of I/O module terminal blocks used for field wiring connections (11pt, 13pt & 20pt). They can be removed from the module for wiring convenience. There are no clips or screws retaining the terminal block. Firmly grip the block and pull it away from the PLC or I/O module. The connector terminal points have recessed screws to help minimize the risk of someone accidentally touching active wiring. Make sure the terminal blocks are properly seated against the module when replacing them and wiring is properly constrained.

For your convenience we also have DINnectors, DIN-rail mounted terminal blocks. Refer to our website or catalog for a complete listing of all available products. We strongly recommend using our *ZIPLinks* connections systems. See the following pages for *ZIPLink* compatibility and special pre-assembled cables, with the I/O connectors installed and wired.

#### *ZIPLinks* Connection Systems



*ZIPLinks* Cables with Connectors

*ZIPLinks* Modules



**WARNING:** For some modules, field device power may still be present on the terminal block even though the PLC system is turned off. To minimize the risk of electrical shock and equipment damage, check all field device power before you remove the connector.

## ZIPLink Wiring System Compatibility Matrix for CLICK PLCs

Use the following tables to select your ZIPLink components. See our website for more specifications and information on ZIPLinks.

CLICK PLC Units ZIPLink Selector				
PLC		ZIPLink		
PLC Module	Terminals	Component	Module Part No.	Cable Part No.
CO-00DD1-D	20	Feedthrough	ZL-RTB20	ZL-CO-CBL20*
CO-00DD2-D				
CO-00DR-D				
CO-00AR-D				
CO-01DD1-D				
CO-01DD2-D				
CO-01DR-D				
CO-01AR-D				
CO-02DD1-D	20	No ZIPLinks are available for analog PLC units.		
CO-02DD2-D				
CO-02DR-D				
CO-10DD1E-D	20	Feedthrough	ZL-RTB20	ZL-CO-CBL20*
CO-10DD2E-D				
CO-10DRE-D				
CO-10ARE-D				
CO-11DD1E-D				
CO-11DD2E-D				
CO-11DRE-D				
CO-11ARE-D				
CO-12DD1E-D	20	No ZIPLinks are available for Ethernet Analog PLC units.		
CO-12DD2E-D				
CO-12DRE-D				
CO-12ARE-D				
CO-12DD1E-1-D				
CO-12DD2E-1-D				
CO-12DRE-1-D				
CO-12ARE-1-D				
CO-12DD1E-2-D				
CO-12DD2E-2-D				
CO-12DRE-2-D				
CO-12ARE-2-D				

\* Select the cable length by replacing the \* with: Blank = 0.5 m, -1 = 1.0 m, or -2 = 2.0 m.

ZIPLink Wiring System Compatibility Matrix for CLICK PLCs (continued)

CLICK PLC Discrete Input Module ZIPLink Selector				
I/O Module		ZIPLink		
Input Module	Terminals	Component	Module Part No.	Cable Part No.
CO-08SIM		Not supported by ZIPLink		
CO-04POT				
CO-08ND3	11	Feedthrough	ZL-RTB20	ZL-CO-CBL11*
CO-08ND3-1				
CO-08NE3				
CO-08NA				
CO-16ND3	20	Feedthrough	ZL-RTB20	ZL-CO-CBL20*
CO-16NE3		Sensor	ZL-LTB16-24-1	
		Feedthrough	ZL-RTB20	
		Sensor	ZL-LTB16-24-1	

\* Select the cable length by replacing the \* with: Blank = 0.5 m, -1 = 1.0 m, or -2 = 2.0 m.

CLICK PLC Discrete Output Module ZIPLink Selector				
I/O Module		ZIPLink		
Output Module	Terminals	Component	Module Part No.	Cable Part No.
CO-08TD1	11	Feedthrough	ZL-RTB20	ZL-CO-CBL11*
CO-08TD2				
CO-08TR				
CO-08TR-3	Not supported by ZIPLink			
CO-08TA	11	Feedthrough	ZL-RTB20	ZL-CO-CBL11*
CO-16TD1	20	Feedthrough	ZL-RTB20	ZL-CO-CBL20*
CO-16TD2		Fuse	ZL-RFU20 <sup>2</sup>	
		Relay (sinking)	ZL-RRL16-24-1	
		Feedthrough	ZL-RTB20	
CO-04TRS <sup>1</sup>		Fuse	ZL-RFU20 <sup>2</sup>	
		Relay (sourcing)	ZL-RRL16-24-2	
CO-04TRS-10	Not supported by ZIPLink			

\* Select the cable length by replacing the \* with: Blank = 0.5 m, -1 = 1.0 m, or -2 = 2.0 m.

<sup>1</sup> NOTE: The CO-04TRS relay output is derated not to exceed 2A per point max. when used with the ZIPLink wiring system.

<sup>2</sup> NOTE: Fuses (5 x 20 mm) are not included. See Edison Electronic Fuse section for (5 x 20 mm) fuse. S500 and GMA electronic circuit protection for fast-acting maximum protection. S506 and GMC electronic circuit protection for time-delay performance. Ideal for inductive circuits. To ensure proper operation, do not exceed the voltage and current rating of ZIPLink module. ZL-RFU20 = 2A per circuit.

## ZIPLink Wiring System Compatibility Matrix for CLICK PLCs (continued)

CLICK PLC Combo I/O Module ZIPLink Selector				
I/O Module		ZIPLink		
Combo Module	# of Terms	Component	Module Part No.	Cable Part No.
C0-16CDD1	20	Feedthrough	ZL-RTB20	ZL-C0-CBL20*
C0-16CDD2				ZL-C0-CBL11*
C0-08CDR	11			

\* Select the cable length by replacing the \* with: Blank = 0.5m, -1 = 1.0m, or -2 = 2.0m.

CLICK PLC Analog I/O Module ZIPLink Selector				
I/O Module		ZIPLink		
Analog Module	# of Terms	Component	Module Part No.	Cable Part No.
C0-04AD-1	11	Feedthrough	ZL-RTB20	ZL-C0-CBL11*
C0-04AD-2	11			
C0-04RTD	20	No ZIPLinks are available for RTD and thermocouple modules.		
C0-04THM	11	Feedthrough	ZL-RTB20	ZL-C0-CBL11*
C0-04DA-1	11			ZL-C0-CBL11*
C0-04DA-2	11			
C0-4AD2DA-1	20			ZL-C0-CBL20*
C0-4AD2DA-2	20			

\* Select the cable length by replacing the \* with: Blank = 0.5m, -1 = 1.0m, or -2 = 2.0m.

## I/O Wiring Checklist

Use the following guidelines when wiring the I/O modules in your system.

1. There is a limit to the size of wire the modules can accept. The table below lists the suggested AWG. When making terminal connections, follow the suggested torque values.

Terminal Block AWG and Torque	
Connector Type (all)	Removable Terminal Block
Wire Range	28-16 AWG
Wire strip length	7.0 mm
Screw Size	M2.0
Screw Torque	Analog, analog combo I/O modules only: 1.7 lb-in; All other modules: 2.0 to 2.2 lb-in



**NOTE:** Recommended wire is 16 AWG Type TFFN or Type MTW. Other types of 16 AWG may be acceptable, depending on the thickness and stiffness of the wire insulation. If the insulation is too thick or stiff, and a majority of the module's I/O points are used, then the plastic terminal cover may not close properly or the connector may pull away from the module. This applies especially for high temperature thermoplastic insulation material such as THHN.

2. Always use a continuous length of wire, do not combine wires to attain a needed length.
3. Use the shortest possible wire length.
4. Use wire trays for routing where possible.
5. Avoid running wires near high energy wiring. Also, avoid running input wiring close to output wiring where possible.
6. To minimize voltage drops when wires must run a long distance, consider using multiple wires for the return line.
7. Avoid running DC wiring in close proximity to AC wiring where possible.
8. Avoid creating sharp bends in the wires.
9. To reduce the risk of having a module damaged, we suggest you add external fuses to your I/O wiring. A fast blow fuse, with a lower current rating than the I/O module fuse, can be added to each common, or a fuse with a rating of slightly less than the maximum current per output point can be added to each output. Refer to our catalog for a complete line of DINnectors, DIN-rail mounted fuse blocks.
10. If using relay outputs with inductive loads, consider using surge suppressors (see section on surge suppression later in this chapter).

## System Wiring Strategies

The CLICK PLC system is very flexible and will work in many different wiring configurations. By studying this section before actual installation, you can find the best wiring strategy for your application. This will help to lower system cost and wiring errors, and avoid safety problems.

### PLC Isolation Boundaries

PLC circuitry is divided into three main regions separated by isolation boundaries, shown in the drawing below. Electrical isolation provides safety, so that a fault in one area does not damage an adjacent area. A powerline filter will provide isolation between the power source and the power supply. The transformer in the power supply provides magnetic isolation between the primary and secondary sides. Optical isolators provide optical isolation in Input and Output circuits. These methods isolate logic circuitry from the field side, where factory machinery connects. The discrete inputs are isolated from the discrete outputs, because each is isolated from the logic side. Isolation boundaries protect the devices such as PC and HMI that are connected to the communication ports, from power input faults or field wiring faults. When wiring a PLC, it is extremely important to avoid making external connections that connect logic side circuits to more than one circuit.

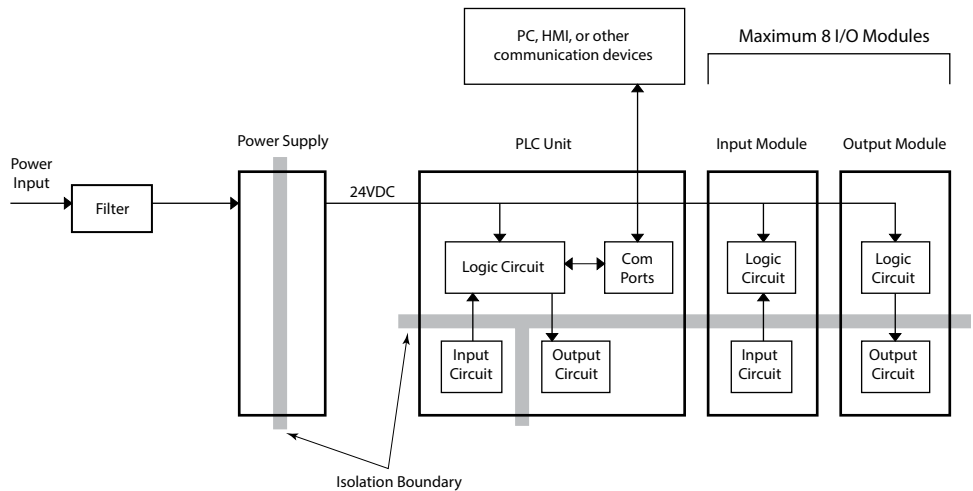

**NOTE:** If you do not use one of the CLICK PLC power supplies C0-00AC and C0-01AC to provide 24VDC to the PLC module (and I/O modules), be sure the power supply you use has isolation with a transformer.

### Powering I/O Circuits

In most applications, it will be necessary to power the input devices from one power source, and to power output loads from another source. Loads often require high-energy AC power, while input sensors use low-energy DC. If a machine operator is likely to come in close proximity to input wiring, then for safety reasons, high-energy output circuits would be isolated.

For the DC input/output circuits, you can use the same power source as the PLC module (and I/O modules). However, you lose the isolation between the logic circuits and the input/output circuits. For AC input/output circuits, you don't need to worry about sharing the 24VDC.

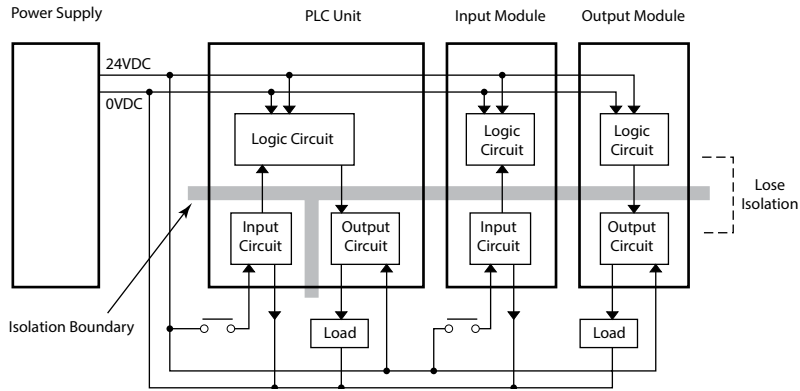

To keep the isolation between the logic circuits and the input/output circuits, we recommend using another power supply for the DC input and output circuits.

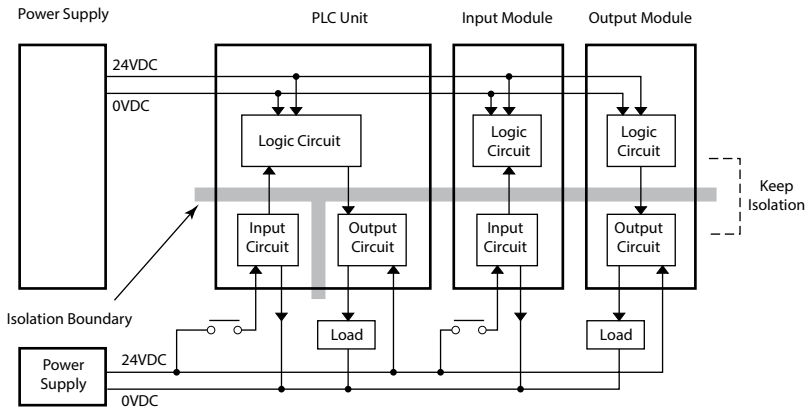

## Sinking/Sourcing Concepts

Before wiring field devices to the PLC I/O, it's necessary to have a basic understanding of sinking and sourcing concepts. Use of these terms occurs frequently in input or output circuit discussions. The purpose of this section is to explain the terms. The short definitions are as follows:

- Sinking = Path to supply ground (-) or switching ground
- Sourcing = Path to supply source (+) or switching +V

These terms only apply to DC circuits, not AC circuits. Input and output points that are either sinking or sourcing can conduct current in only one direction. This means it is possible to wire the external supply and field device to the I/O point with current trying to flow in the wrong direction, in which case the circuit will not operate.

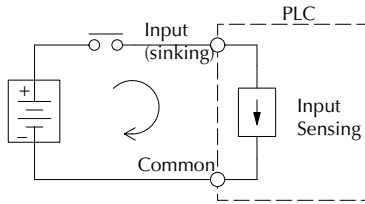

The diagram on the left shows a sinking PLC input. To properly connect the external supply, connect it so the input provides a path to ground (-). Start at the PLC input terminal, follow through the input sensing circuit, exit at the common terminal, and connect the supply (-) to the common terminal.

The switch between the supply (+) and the input completes the circuit. Current flows in the direction of the arrow when the switch is closed. By applying the circuit principle above to the four possible combinations of input/output sinking/sourcing types, we have the four circuits as shown below.

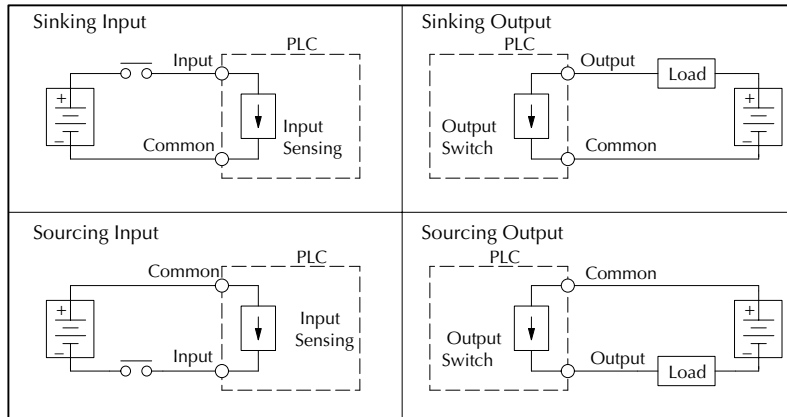

### I/O “Common Terminal” Concepts

In order for a PLC I/O circuit to operate, current must enter at one terminal and exit at another. This means at least two terminals are associated with every I/O point. In the figure to the right, the input or output terminal is the main path for the current. One additional terminal must provide the return path to the power supply.

If there was unlimited module space, then every I/O point could have two dedicated terminals as the figure above shows. Providing this level of flexibility is not practical or necessary for most applications. So, most I/O point groups share the return path (common) among two or more I/O points. The figure to the right shows a group (or bank) of 4 input points which share a common return path. In this way, the four inputs require only five terminals instead of eight.

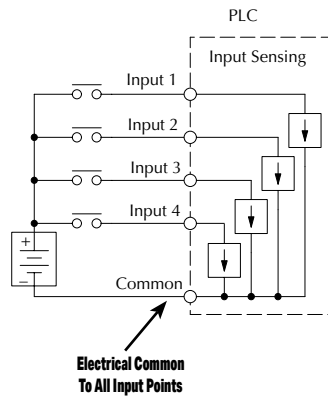
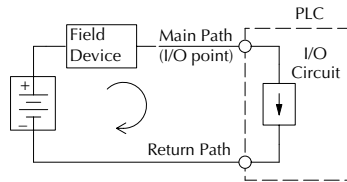

**NOTE:** In the circuit above, the current in the common path is equal to the sum of the energized channels. This is especially important in output circuits, where larger gauge wire is sometimes needed for the commons.



## DC Input Wiring Methods

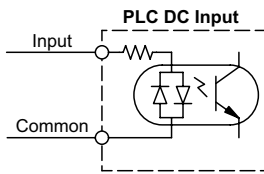

CLICK PLCs and I/O modules with DC inputs can be wired as either sinking or sourcing inputs. The dual diodes (shown in this diagram) allow current to flow in either direction. Inputs grouped by a common point must be either all sinking or all sourcing. DC inputs typically operate in the range of +12-24 VDC.

### Sinking Input Sensor (NPN Type) to PLC Sourcing Input

In the following example, a field device has an open-collector NPN transistor output. When energized, it sinks current to ground from the DC input point. The PLC input current is sourced from the common terminal connected to power supply (+).

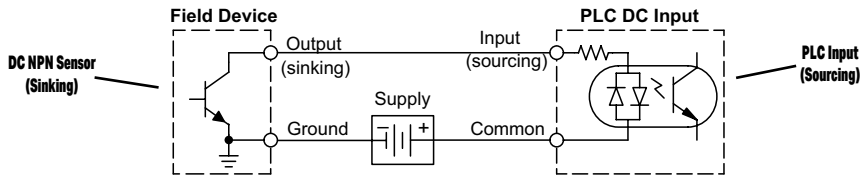

### Sourcing Input Sensor (PNP Type) to PLC Sinking Input

In the following example, a field device has an open-emitter PNP transistor output. When energized, it sources current to the PLC input point, which sinks the current to ground. Since the field device loop is sourcing current, no additional power supply is required for the module.

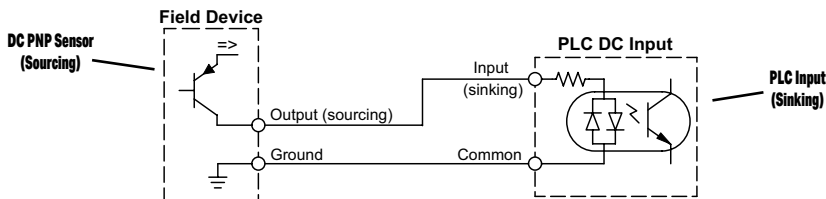

## DC Output Wiring Methods

CLICK PLCs and I/O modules with DC output circuits are wired as all current sinking only or current sourcing only depending on which PLC or output module part number is used. DC outputs typically operate in the range of +5-24 VDC.

### PLC Sinking Output to Sourcing Load Device

Many applications require connecting a PLC output point to a DC input on a field device load. This type of connection is made to carry a low-level DC signals.

In the following example, the PLC output point sinks current to ground (common) when energized. The output is connected to a field device load with a sourcing input.

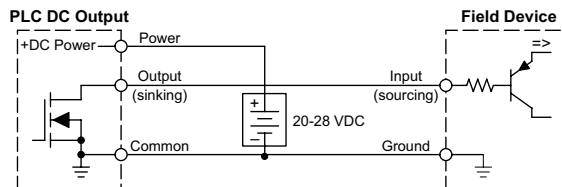

### PLC DC Sinking Output to Sinking Load Device

In the example below, a PLC sinking output point is connected to the sinking input of a field device load. In this case, both the PLC output and field device input are sinking type. Since the circuit must have one sourcing and one sinking device, we add sourcing capability to the PLC output by using a pull-up resistor. In the circuit below, we connect  $R_{\text{pull-up}}$  from the output to the DC output circuit power input.

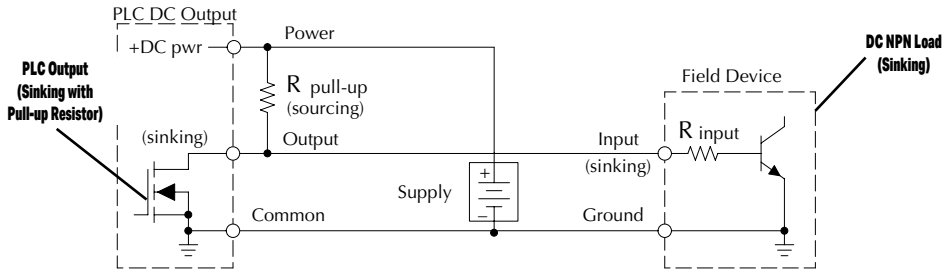

**NOTE 1:** DO NOT attempt to drive a heavy load (>25 mA) with this pull-up method.

**NOTE 2:** Using the pull-up resistor to implement a sourcing output has the effect of inverting the output point logic. In other words, the field device input is energized when the PLC output is OFF, from a ladder logic point-of-view. Your ladder program must comprehend this and generate an inverted output. Or, you may choose to cancel the effect of the inversion elsewhere, such as in the field device.

It is important to choose the correct value of  $R_{\text{pull-up}}$ . In order to do so, we need to know the nominal input current to the field device ( $I_{\text{input}}$ ) when the input is energized. If this value is not known, it can be calculated as shown (a typical value is 15 mA). Then use  $I_{\text{input}}$  and the voltage of the external supply to compute  $R_{\text{pull-up}}$ . Then calculate the power  $P_{\text{pull-up}}$  (in watts), in order to size  $R_{\text{pull-up}}$  properly.

$$I_{\text{input}} = \frac{V_{\text{input (turn-on)}}}{R_{\text{input}}}$$

$$R_{\text{pull-up}} = \frac{V_{\text{supply}} - 0.7}{I_{\text{input}}} - R_{\text{input}}$$

$$P_{\text{pull-up}} = \frac{V_{\text{supply}}^2}{R_{\text{pull-up}}}$$

## Relay Outputs - Wiring Methods

Relay outputs are available for the CLICK PLCs. Relays are best for the following applications:

- Loads that require higher currents than the solid-state outputs can deliver
- Cost-sensitive applications
- Some output channels need isolation from other outputs (such as when some loads require different voltages than other loads)

Some applications in which NOT to use relays:

- Loads that require currents under 10mA
- Loads which must be switched at high speed or heavy duty cycle

**Relay with Form A contacts**

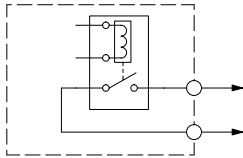

Relay outputs in the CLICK PLCs and modules are available in two contact arrangements. Form A type, or SPST (single pole, single throw) type. They are normally open and are the simplest to use. The Form C, or SPDT (single pole, double throw) type has a center contact which moves and a stationary contact on either side. This provides a normally closed contact and a normally open contact.

**Relay with Form C contacts**

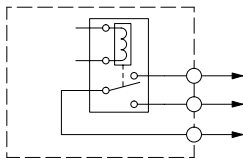

Some relay output module's relays share common terminals, which connect to the wiper contact in each relay of the bank. Other relay modules have relays which are completely isolated from each other. In all cases, the module drives the relay coil when the corresponding output point is on.

### Relay Outputs – Transient Suppression for Inductive Loads in a Control System

The following pages are intended to give a quick overview of the negative effects of transient voltages on a control system and provide some simple advice on how to effectively minimize them. The need for transient suppression is often not apparent to the newcomers in the automation world. Many mysterious errors that can afflict an installation can be traced back to a lack of transient suppression.

#### What is a Transient Voltage and Why is it Bad?

Inductive loads (devices with a coil) generate transient voltages as they transition from being energized to being de-energized. If not suppressed, the transient can be many times greater than the voltage applied to the coil. These transient voltages can damage PLC outputs or other electronic devices connected to the circuit, and cause unreliable operation of other electronics in the general area. Transients must be managed with suppressors for long component life and reliable operation of the control system.

This example shows a simple circuit with a small 24V/125mA/3W relay. As you can see, when the switch is opened, thereby de-energizing the coil, the transient voltage generated across the switch contacts peaks at 140V.

Example: Circuit with no Suppression

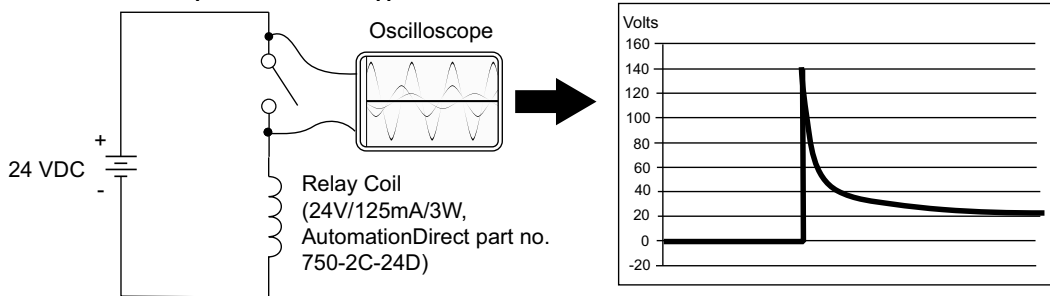

In the same circuit, replacing the relay with a larger 24V, 290mA, 7W relay will generate a transient voltage exceeding 800V (not shown). Transient voltages like this can cause many problems, including:

- Relay contacts driving the coil may experience arcing, which can pit the contacts and reduce the relay's lifespan.
- Solid state (transistor) outputs driving the coil can be damaged if the transient voltage exceeds the transistor rating. In extreme cases, complete failure of the output can occur the very first time a coil is de-energized.
- Input circuits, which might be connected to monitor the coil or the output driver, can also be damaged by the transient voltage.

A very destructive side-effect of the arcing across relay contacts is the electromagnetic interference (EMI) it can cause. This occurs because the arcing causes a current surge, which releases RF energy. The entire length of wire between the relay contacts, the coil, and the power source carries the current surge and becomes an antenna that radiates the RF energy. It will readily couple into parallel wiring and may disrupt the PLC and other electronics in the area. This EMI can make an otherwise stable control system behave unpredictably at times.

### PLC's Integrated Transient Suppressors

Although the PLC's outputs typically have integrated suppressors to protect against transients, they are not capable of handling them all. It is usually necessary to have some additional transient suppression for an inductive load.

Here is another example using the same 24V, 125mA, 3W relay used earlier. This example measures the PNP transistor output of a D0-06DD2 PLC, which incorporates an integrated Zener diode for transient suppression. Instead of the 140V peak in the first example, the transient voltage here is limited to about 40V by the Zener diode. While the PLC will probably tolerate repeated transients in this range for some time, the 40V is still beyond the module's peak output voltage rating of 30V.

#### Example: Small Inductive Load with Only Integrated Suppression

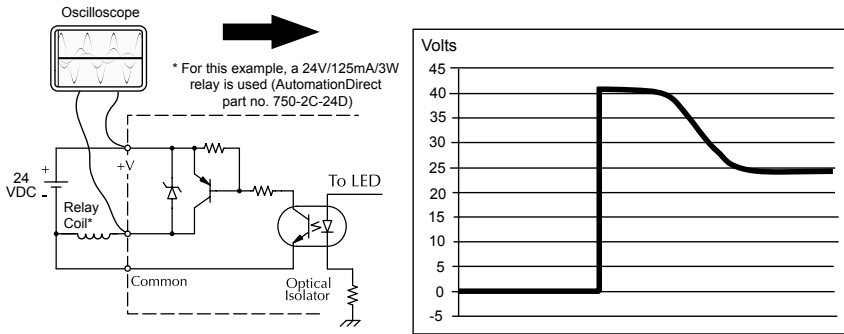

The next example uses the same circuit as above, but with a larger 24V, 290mA, 7W relay thereby creating a larger inductive load. As you can see, the transient voltage generated is much worse, peaking at over 50V. Driving an inductive load of this size without additional transient suppression is very likely to permanently damage the PLC output.

#### Example: Larger Inductive Load with Only Integrated Suppression

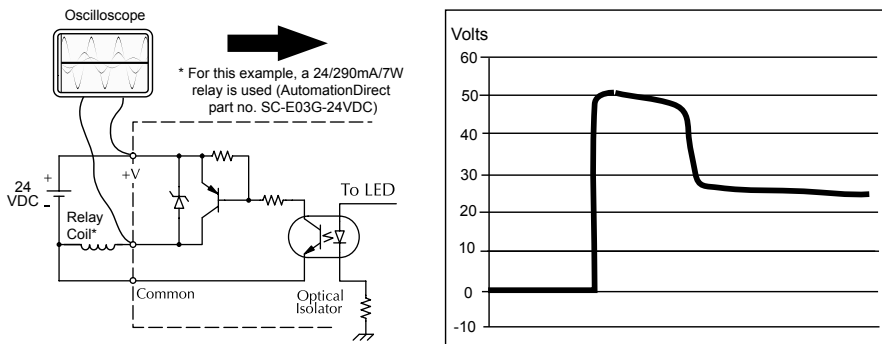

Additional transient suppression should be used in both these examples. If you are unable to measure the transients generated by the connected loads of your control system, using additional transient suppression on all inductive loads would be the safest practice.

### Types of Additional Transient Protection

#### DC Coils:

The most effective protection against transients from a DC coil is a flyback diode. A flyback diode can reduce the transient to roughly 1V over the supply voltage, as shown in this example.

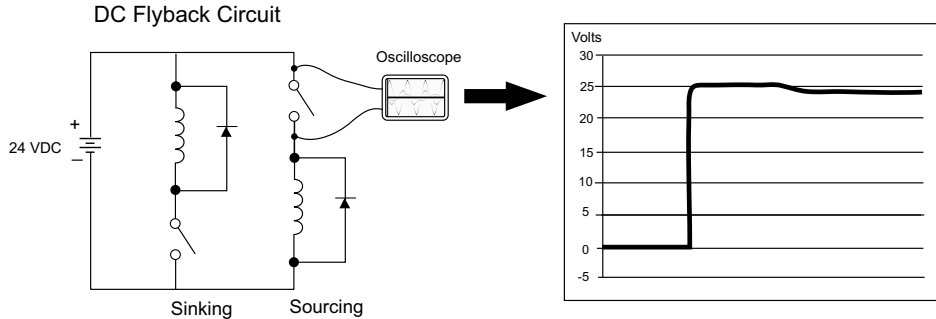

Many AutomationDirect socketed relays and motor starters have add-on flyback diodes that plug or screw into the base, such as the AD-ASMD-250 protection diode module and 784-4C-SKT-1 socket module shown below. If an add-on flyback diode is not available for your inductive load, an easy way to add one is to use an AutomationDirect DN-D10DR-A diode terminal block, a 600VDC power diode mounted in a slim DIN rail housing.



**AD-ASMD-250**  
Protection Diode Module



**784-4C-SKT-1**  
Relay Socket

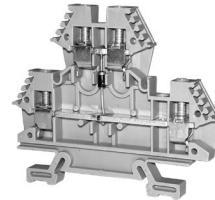

**DN-D10DR-A**  
Diode Terminal Block

Two more common options for DC coils are Metal Oxide Varistors (MOV) or TVS diodes. These devices should be connected across the driver (PLC output) for best protection as shown below. The optimum voltage rating for the suppressor is the lowest rated voltage available that will NOT conduct at the supply voltage, while allowing a safe margin.

AutomationDirect's ZL-TSD8-24 transorb module is a good choice for 24VDC circuits. It is a bank of 8 uni-directional 30V TVS diodes. Since they are uni-directional, be sure to observe the polarity during installation. MOVs or bi-directional TVS diodes would install at the same location, but have no polarity concerns.



**ZL-TSD8-24**  
Transorb Module

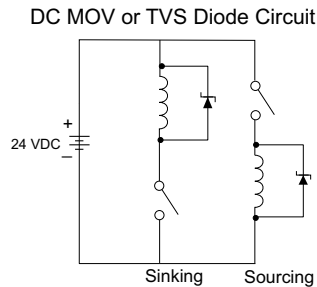

### AC Coils:

Two options for AC coils are MOVs or bi-directional TVS diodes. These devices are most effective at protecting the driver from a transient voltage when connected across the driver (PLC output) but are also commonly connected across the coil. The optimum voltage rating for the suppressor is the lowest rated voltage available that will NOT conduct at the supply voltage, while allowing a safe margin.

AutomationDirect's ZL-TSD8-120 transorb module is a good choice for 120VAC circuits. It is a bank of eight bi-directional 180V TVS diodes.



**ZL-TSD8-120**  
Transorb Module

AC MOV or Bi-Directional Diode Circuit

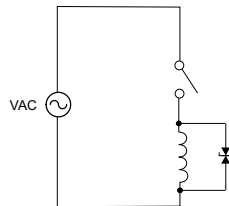

**NOTE:** Manufacturers of devices with coils frequently offer MOV or TVS diode suppressors as an add-on option which mount conveniently across the coil. Before using them, carefully check the suppressor ratings. Just because the suppressor is made specifically for that part does not mean it will reduce the transient voltages to an acceptable level.

For example, a MOV or TVS diode rated for use on 24-48 VDC coils would need to have a high enough voltage rating to NOT conduct at 48V. That suppressor might typically start conducting at roughly 60VDC. If it were mounted across a 24V coil, transients of roughly 84V (if sinking output) or -60V (if sourcing output) could reach the PLC output. Many semiconductor PLC outputs cannot tolerate such levels.

## Analog I/O Configuration

Built-in Analog I/O are available in the CLICK models listed below. (Expansion Analog I/O modules are shown on following page.)

Analog PLC Units	Inputs	Outputs
C0-02DD1-D	2 - Current/ Voltage, Selectable	2 - Current/ Voltage, Selectable
C0-02DD2-D		
C0-02DR-D		
C0-12DD1E-D		
C0-12DD2E-D		
C0-12DRE-D		
C0-12ARE-D		
C0-12DD1E-1-D	4 - Current only	2 - Current only
C0-12DD2E-1-D		
C0-12DRE-1-D		
C0-12ARE-1-D		
C0-12DD1E-2-D	4 - Voltage only	2 - Voltage only
C0-12DD2E-2-D		
C0-12DRE-2-D		
C0-12ARE-2-D		

### Terminal Block Wiring - Analog PLC Units

The (non-Ethernet) Analog PLC units have two built-in analog inputs and two built-in analog outputs. You can select analog voltage or analog current for each analog I/O separately. As shown below, you must use the proper terminal when using analog voltage or analog current.

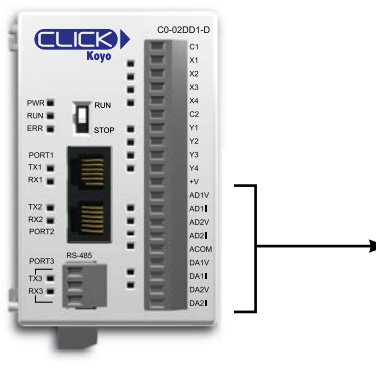

Analog Terminals	
Terminal Name	Terminal Description
AD1V	Analog voltage input
AD1I	Analog current input
AD2V	Analog voltage input
AD2I	Analog current input
ACOM	Common for all analog inputs and outputs
DA1V	Analog voltage output
DA1I	Analog current output
DA2V	Analog voltage output
DA2I	Analog current output

Some Ethernet Analog PLC units have two built-in analog inputs and two built-in analog outputs.

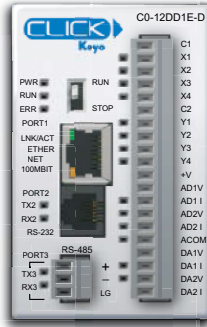

Ethernet Analog Terminals	
Terminal Name	Terminal Description
AD1V	Analog voltage input
AD1I	Analog current input
AD2V	Analog voltage input
AD2I	Analog current input
ACOM	Common for all analog inputs and outputs
DA1V	Analog voltage output
DA1I	Analog current output
DA2V	Analog voltage output
DA2I	Analog current output

Some Ethernet Analog PLC units have four built-in (current or voltage) analog inputs and two analog outputs.

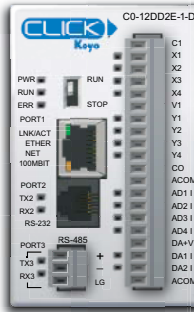

Ethernet Analog Current Terminals	
Terminal Name	Terminal Description
ACOM	Common for analog inputs
AD1I- AD4I	Analog current input
DA+V	Analog voltage source
DA1I- DA2I	Analog current output
ACOM	Common for analog outputs

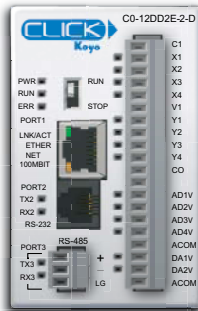

Ethernet Analog Voltage Terminals	
Terminal Name	Terminal Description
AD1V- AD4V	Analog voltage input
ACOM	Common for analog inputs
DA1V- DA2V	Analog voltage output
ACOM	Common for analog outputs

### Terminal Block Wiring - Expansion Analog I/O Modules

The terminal block wiring will vary depending on which analog I/O module is being used. For example, the C0-04AD-1 module shown here has four analog terminals, CH1 through CH4, which are all current inputs.

See Chapter 2. Specifications for terminal block wiring diagrams and specifications for all the analog I/O modules.

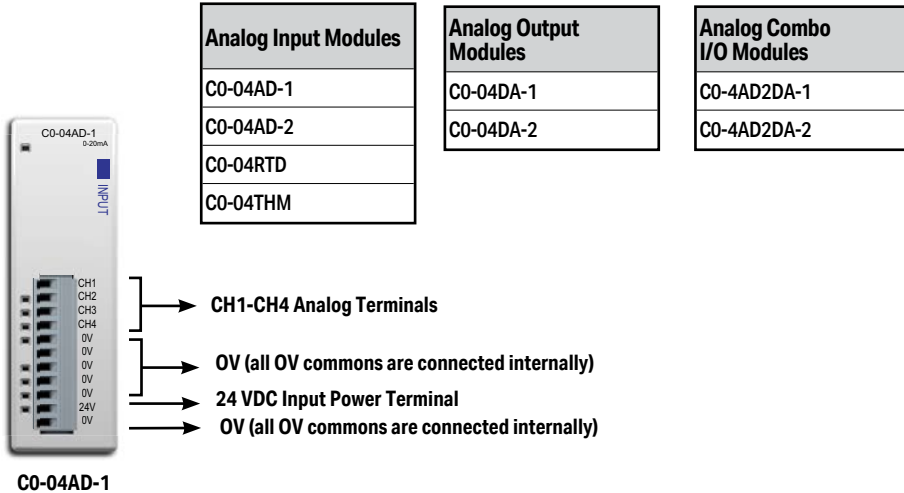

## Configuration in the CLICK Programming Software

All analog I/O points can be configured in the CLICK Programming Software. There is no jumper switch in these modules.

### Analog PLC units

The Analog PLC units cannot detect which terminal is used between the analog voltage and analog current, so you must configure which analog type is used for each analog I/O in the CLICK programming software.

Connect the CLICK programming software to the Analog PLC unit, then open the CPU Built-in I/O Setup window as shown below.

(Pull-down menu: Setup > CPU Built-in I/O Setup)

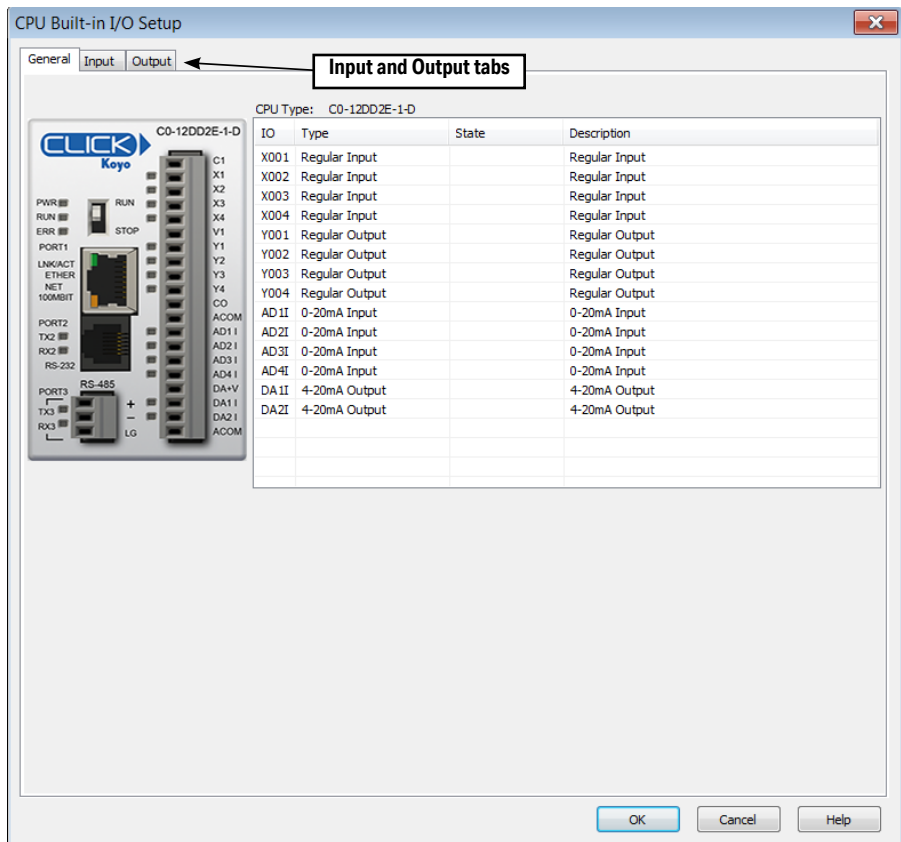

Click the Input tab to configure the analog inputs and/or click the Output tab to configure the analog outputs. The Input tab is shown below, but the Output tab looks very similar.

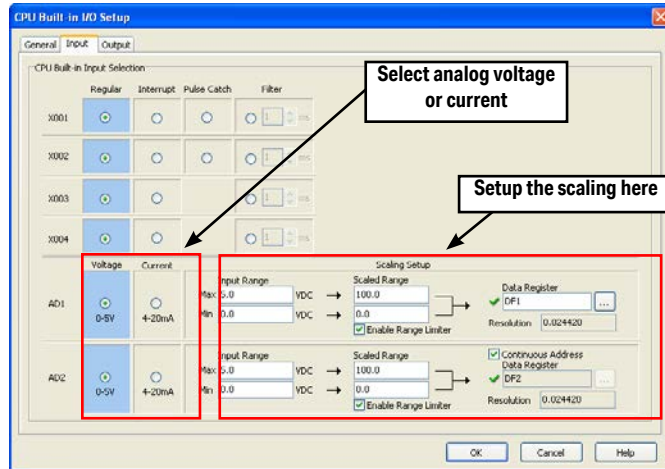

You can select the analog voltage or analog current with the radio buttons. Also use this screen to set the scaling for each Analog I/O. Click the Help button on the right bottom to learn about the scaling feature.

After you configure the Analog I/O, download the project into the Analog PLC module.

### Analog I/O Modules

To configure an Analog I/O module, connect the CLICK programming software to the CLICK PLC including the Analog I/O module, then open the System Configuration window as shown below (Pull-down menu: Setup > System Configuration).

Click the 'Config...' button to open the configuration window to configure each analog I/O module.

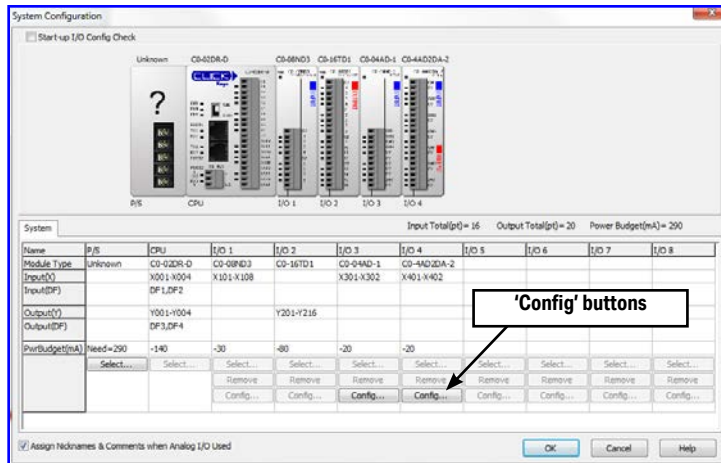

The following is the configuration window for the C0-04AD-1 current input I/O module.

C0-04AD-1 Setting
X

Continuous Address

CH1	0 - 20mA	Input Range Max: 20.0 mA Min: 0.0 mA	→	Scale Range 100.0 0.0	} →	Data Register <input checked="" type="checkbox"/> <input style="width: 50px;" type="text"/> ... Resolution: 0.0122085
CH2	0 - 20mA	Input Range Max: 20.0 mA Min: 0.0 mA	→	Scale Range 100.0 0.0	} →	Data Register <input checked="" type="checkbox"/> <input style="width: 50px;" type="text"/> ... Resolution: 0.0122085
CH3	0 - 20mA	Input Range Max: 20.0 mA Min: 0.0 mA	→	Scale Range 100.0 0.0	} →	Data Register <input checked="" type="checkbox"/> <input style="width: 50px;" type="text"/> ... Resolution: 0.0122085
CH4	0 - 20mA	Input Range Max: 20.0 mA Min: 0.0 mA	→	Scale Range 100.0 0.0	} →	Data Register <input checked="" type="checkbox"/> <input style="width: 50px;" type="text"/> ... Resolution: 0.0122085

Enable Range Limiter

X301 = Should be mentioned that it is the Watchdog Error bit  
 X302 = On when external 24VDC input missing.

In the CLICK PLC, all analog data is stored in the DF memory addresses. Assign DF memory addresses to the Data Register fields. You can also set up the scaling in this configuration window. For more detailed explanation about this configuration window, refer to the help topic by clicking the Help button on the bottom right corner.

After configuring all the analog I/O modules, download the CLICK project into the CLICK PLC.

### Analog I/O Monitoring

To monitor the current analog I/O values, you can use the System Monitor window as shown below (Pull-down menu: Monitor > System Monitor).

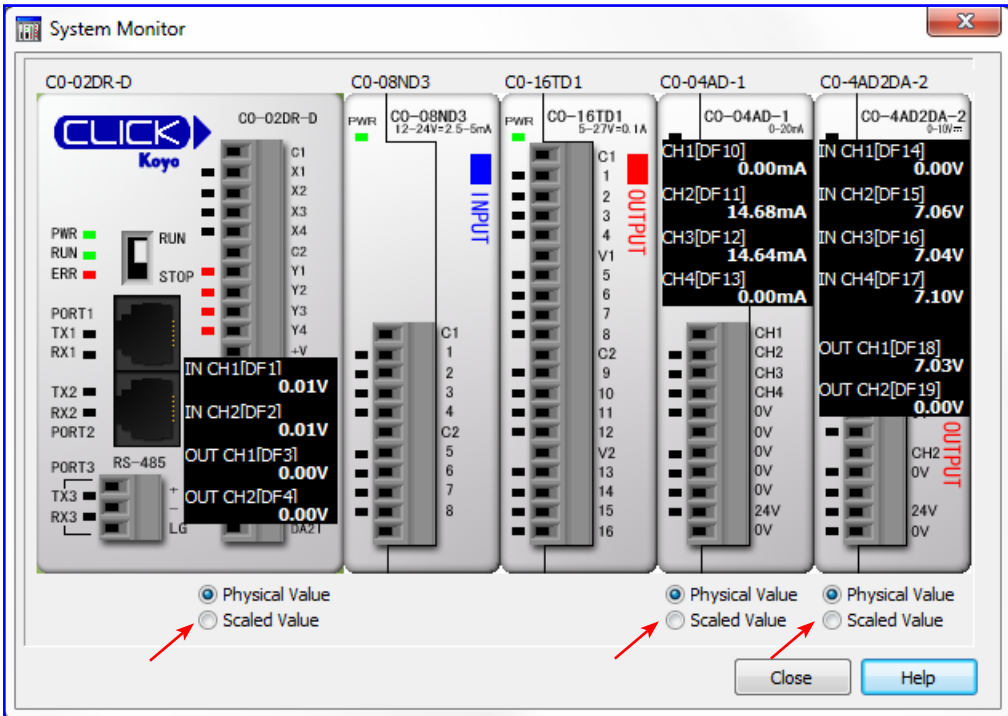

You can switch the displayed values between the physical values and scaled values with the radio buttons below the respective graphic.

## High-Speed Input Configuration

CLICK CPUs that have built-in digital inputs with High-Speed capability are shown below. The maximum number of available Single Input Counters will depend on the combination of features used.

CPU Type	CPU Part Number	High-Speed Input Points	High-Speed Counters (Max.)
Ethernet Basic	C0-10DD1E-D	4	4
	C0-10DD2E-D		
	C0-10DRE-D		
	C0-10ARE-D	N/A	N/A
Ethernet Standard	C0-11DD1E-D	8	6
	C0-11DD2E-D		
	C0-11DRE-D		
	C0-11ARE-D	N/A	N/A
Ethernet Analog	C0-12DD1E-D	4	4
	C0-12DD2E-D		
	C0-12DRE-D		
	C0-12ARE-D	N/A	N/A
	C0-12DD1E-1-D	4	4
	C0-12DD2E-1-D		
	C0-12DRE-1-D		
	C0-12ARE-1-D	N/A	N/A
	C0-12DD1E-2-D	4	4
	C0-12DD2E-2-D		
	C0-12DRE-2-D		
C0-12ARE-2-D	N/A	N/A	

## Chapter 3: Installation and Wiring

Each Input Mode consumes the available number of High-Speed Inputs. The Reset and Enable features can use High-Speed Inputs, Digital Input Modules, or Control Relays (Internal Bits). The transition delay (latency) is longer for Input Modules and Control Relays since these are scan based.

High-Speed Mode	Input Type	High-Speed Inputs Required	Reset Input	Enable Input
High-Speed Count (HSC)	Up Count	1	Optional	Optional
	Down Count			
	Up and Down Counts	2		
	Pulse and Direction			
	Quadrature (A and B)			
	Quadrature (A and B with Z)	3	N/A	
Interval Measurement (ITV)	Single Input	1	Optional	
	Dual Inputs	2		
Duration Measurement (DUR)	Single Input	1		
Frequency Measurement (FRQ)	Single Input	1	N/A	N/A
	Quadrature (A and B)	2		

## Wiring Examples High Speed Inputs

### Quadrature with Reset (Z-Pulse):

Sinking Encoder (Open Collector)

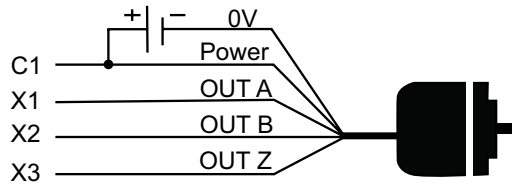

Sourcing Encoder

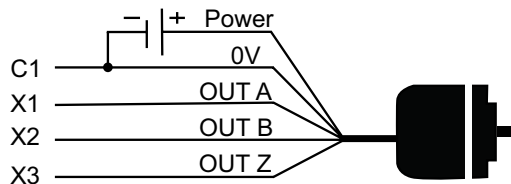

### 3-Wire Sensors

NPN Sensor (Sinking)

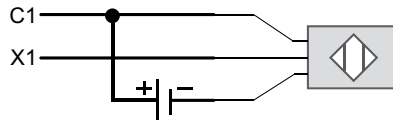

PNP Sensor (Sourcing)

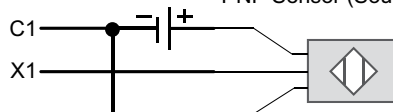

# PLC COMMUNICATIONS

---



## In This Chapter...

Introduction .....	4-2
PLC Communication Ports Specifications .....	4-3
LED Status Indicators .....	4-5
3 Steps to Using the CLICK PLC Communications .....	4-7
Typical Communication Applications .....	4-8
W-1: Com Port 1 & 2 (RS-232) Wiring .....	4-12
W-2: Com Port 1 (Ethernet) Wiring .....	4-17
W-3: Com Port 3 Wiring .....	4-19
C-1: Com Port 1 (RS-232) Setup .....	4-20
C-2: Com Port 1 (Ethernet) Setup .....	4-21
C-3: Com Port 2 Setup (Modbus RTU) .....	4-22
C-4: Com Port 2 Setup (ASCII) .....	4-23
C-5: Com Port 3 Setup (Modbus RTU) .....	4-24
C-6: Com Port 3 Setup (ASCII) .....	4-25
P-1: Modbus Slave (Server) Programming .....	4-26
P-2: Modbus Master Programming (Modbus RTU) .....	4-29
P-3: Modbus Client (Modbus TCP) Programming .....	4-34
P-4: ASCII Receive Programming .....	4-40
P-5: ASCII Send Programming .....	4-43

# Introduction

This chapter explains the communications ability of the CLICK PLC system for exchanging data between the PLC unit and other connected serial devices. It covers:

- Electrical connections used for communications
- Networking routing between the PLC and other devices,
- Setting the port communication parameters,
- Selecting the protocols and the available data addressing types to use, and
- Ladder logic program instructions that make it all work together.

CLICK Basic and Standard PLCs have two built-in RS-232 ports. Both ports are 6-pin RJ12 phone type jacks. Port 1 communication parameters are fixed and is used primarily as the programming port. Port 1 can also be used as a Modbus RTU protocol slave device. Port 2 is a general purpose port, user configurable, with its communication parameters within CLICK Programming Software, C0-PGMSW. Port 2 can be used as a Modbus RTU master or slave protocol device, or handle ASCII data In or Out (ASCII stands for American Standard Code for Information Interchange and defines a character encoding method for text that is used in computers and other communication devices. Details can be found by doing a search for ASCII on the internet).

Standard and Analog PLC versions also have a 3-pin RS-485 port, Port 3. Like Port 2, Port 3 is a general purpose port with its communication parameters being user configurable from the programming software. Port 3 can be used as a Modbus RTU master or slave protocol device, or handle ASCII data In or Out.

CLICK Ethernet Basic, Standard and Analog PLC units have one built-in Ethernet communications port and one RS-232 serial communication port. Additionally, Ethernet Standard and Analog PLC units have an RS-485 port.

The CLICK PLC can be networked to other CLICK PLCs, data input devices (barcode readers, weight scales, etc.), and/or data output devices (serial printers, serial text displays, etc.). It is also possible to network the CLICK PLC to other 3rd party PLCs and devices that have the ability to communicate using the Modbus RTU protocol.

The final part of the PLC Communications chapter contains explanations and examples of the various ways the Send and Receive programming instructions can be used to perform Modbus RTU protocol and ASCII data communications between devices.

There are three different data addressing types that can be selected when using the Modbus RTU protocol from the Send and Receive instructions. They are, CLICK addressing, Modbus 984 addressing, or Modbus HEX addressing. The CLICK addressing makes it convenient to exchange data between CLICK PLCs. The other addressing choices are selected based on the Modbus protocol addressing the networked devices are using. For details on the Modbus protocol, visit [www.modbus.org](http://www.modbus.org).



---

**NOTE:** *The Modbus RTU Master is identified as the device that controls the exchange of data between itself and any connected slave device. There can only be one master on the network. When the CLICK PLC is the master, it is easily identified. It will be the PLC in the network with the Send and/or Receive instructions using the Modbus protocol in its ladder logic program.*

---

# PLC Communication Ports Specifications

The CLICK PLC units have two or three built-in communications ports.

Basic PLC

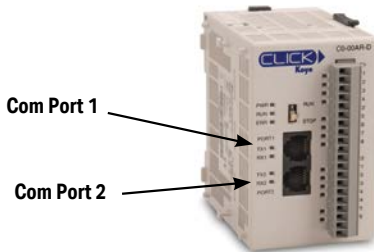

Standard and Analog PLCs

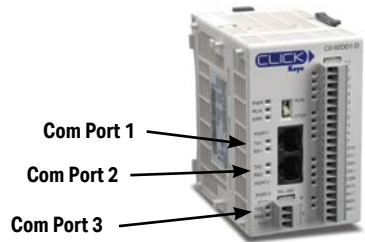

### Com Port 1 Specifications

Use: Programming Port
Physical: 6 pin, RJ12, RS-232
Communication speed (baud): 38400 (fixed)
Parity: Odd
Station Address: 1
Data length: 8 bits
Stop bit: 1
Protocol: Modbus RTU (slave only)

Port 1

6 pin RJ12 Phone Type Jack

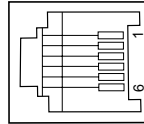

### Port 1 Pin Descriptions

1	0V	Power (-) connection (GND)
2	5V	Power (+) connection
3	RXD	Receive data (RS-232)
4	TXD	Transmit data (RS-232)
5	NC	No connection
6	0V	Power (-) connection (GND)

### Com Port 2 Specifications

### Default

Use: Serial Communication	-
Physical: 6 pin, RJ12, RS-232	-
Communication speed (baud): 1200, 2400, 4800, 9600, 19200, 38400, 57600, 115200	38400
Parity: odd, even, none	Odd
Station Address: 1 to 247	1
Data length: 8 bits (Modbus RTU) or 7, 8 bits (ASCII)	8 bits
Stop bit: 1,2	1
Protocol: Modbus RTU (master/slave) or ASCII in/out	Modbus RTU

Port 2

6 pin RJ12 Phone Type Jack

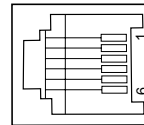

### Port 2 Pin Descriptions

1	0V	Power (-) connection (GND)
2	5V	Power (+) connection
3	RXD	Receive data (RS-232)
4	TXD	Transmit data (RS-232)
5	RTS	Request to send
6	0V	Power (-) connection (GND)

### Com Port 3 Specifications

### Default

Use: Serial Communication	-
Physical: 3 pin, RS-485	-
Communication speed (baud): 1200, 2400, 4800, 9600, 19200, 38400, 57600, 115200	38400
Parity: odd, even, none	Odd
Station Address: 1 to 247	1
Data length: 8 bits (Modbus RTU) or 7, 8 bits (ASCII)	8 bits
Stop bit: 1,2	1
Protocol: Modbus RTU (master/slave) or ASCII in/out	Modbus RTU

Port 3

3 Pin Terminal Block

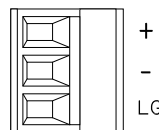

### Port 3 Pin Descriptions

1	+ (Plus)	Signal A (RS-485)
2	- (Minus)	Signal B (RS-485)
3	LG	Logic Ground(0 V)

# PLC Communication Ports Specifications (continued)

Ethernet Basic PLC

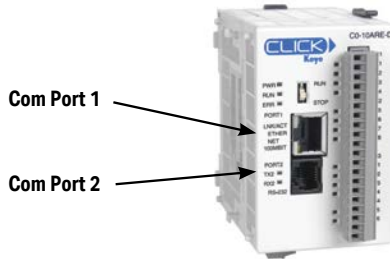

Ethernet Standard and Analog PLCs

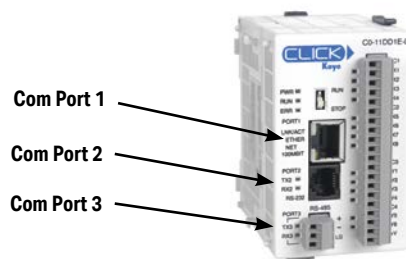

### Com Port 1 Specifications

Use: Programming and Ethernet Communication
Physical: 8 pin, RJ45, Ethernet
Communication Speed (Mbps): 10/100
Protocol: Modbus TCP (client/server), EtherNet/IP Implicit and Explicit (adapter server)

Port 1

8 pin RJ45 Phone Type Jack

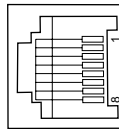

### Port 1 Pin Descriptions

1	TX+	Transmit Data (+)
2	TX-	Transmit Data (-)
3	RX+	Receive Data (+)
4	NC	Not connected
5	NC	Not connected
6	RX-	Receive Data (-)
7	NC	Not connected
8	NC	Not connected

### Com Port 2 Specifications

### Default

Use: Serial Communication	-
Physical: 6 pin, RJ12, RS-232	-
Communication speed (baud): 2400, 4800, 9600, 19200, 38400, 57600, 115200	38400
Parity: odd, even, none	Odd
Station Address: 1 to 247	1
Data length: 8 bits (Modbus RTU) or 7, 8 bits (ASCII)	8 bits
Stop bit: 1,2	1
Protocol: Modbus RTU (master/slave) or ASCII in/out	Modbus RTU

Port 2

6 pin RJ12 Phone Type Jack

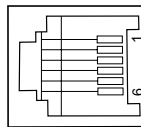

### Port 2 Pin Descriptions

1	0V	Power (-) connection (GND)
2	5V	Power (+) connection
3	RXD	Receive data (RS-232)
4	TXD	Transmit data (RS-232)
5	RTS	Request to send
6	0V	Power (-) connection (GND)

### Com Port 3 Specifications

### Default

Use: Serial Communication	-
Physical: 3 pin, RS-485	-
Communication speed (baud): 2400, 4800, 9600, 19200, 38400, 57600, 115200	38400
Parity: odd, even, none	Odd
Station Address: 1 to 247	1
Data length: 8 bits (Modbus RTU) or 7, 8 bits (ASCII)	8 bits
Stop bit: 1,2	1
Protocol: Modbus RTU (master/slave) or ASCII in/out	Modbus RTU

Port 3

3 Pin Terminal Block

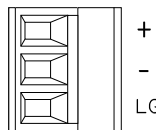

### Port 3 Pin Descriptions

1	+ (plus)	Signal A (RS-485)
2	- (minus)	Signal B (RS-485)
3	LG	Logic Ground(0 V)

# LED Status Indicators

## LED Status Indicators

There are LED status indicators located to the left of each communication port to indicate port activity or communications.

Port 1 & 2 LED Status Indicators

TX1 and TX2 (Green)	
On	The Comm Port is sending data.
Off	The Comm Port is not sending data.
RX1 and RX2 (Green)	
On	The Comm Port is receiving data.
Off	The Comm Port is not receiving data.

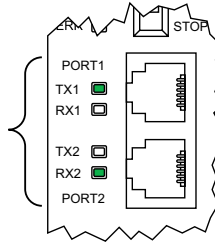

Basic PLC



Port 1, 2, & 3 LED Status Indicators

TX1, TX2 and TX3 (Green)	
On	The Comm Port is sending data.
Off	The Comm Port is not sending data.
RX1, RX2 and RX3 (Green)	
On	The Comm Port is receiving data.
Off	The Comm Port is not receiving data.

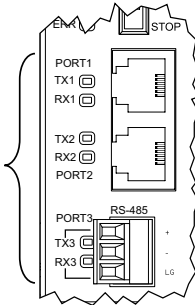

Standard and Analog PLCs



## DirectLogic Devices That Do Not Work With CLICK PLCs

The CLICK PLC does not support K-sequence protocol, so the following DirectLogic devices do not work with the CLICK PLC:



D2-HPP



D4-HPP-1



DV-1000

# LED Status Indicators (continued)

Port 1 & 2 LED Status Indicators

LNK/ACT LED (Green)	
On	Connected to the network
Blink	Communicating
Off	Disconnected from the network
100MBIT LED (Orange)	
On	Communicating at 100Mbps
Off	Communicating at 10Mbps or disconnected from the network
TX2 (Green)	
On	The Comm Port is sending data.
Off	The Comm Port is not sending data.
RX2 (Green)	
On	The Comm Port is receiving data.
Off	The Comm Port is not receiving data.

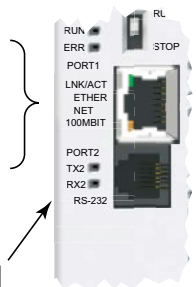

Ethernet Basic PLC



Port 1, 2, & 3 LED Status Indicators

LNK/ACT LED (Green)	
On	Connected to the network
Blink	Communicating
Off	Disconnected from the network
100MBIT LED (Orange)	
On	Communicating at 100Mbps
Off	Communicating at 10Mbps or disconnected from the network
TX2 and TX3 (Green)	
On	The Comm Port is sending data.
Off	The Comm Port is not sending data.
RX2 and RX3 (Green)	
On	The Comm Port is receiving data.
Off	The Comm Port is not receiving data.

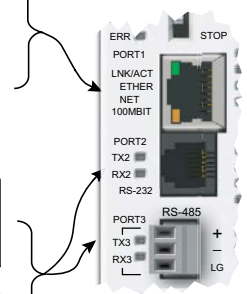

Ethernet Standard and Analog PLCs



### 3 Steps to Using the CLICK PLC Communications

We offer an easy 3-step method for using the communication features of the CLICK PLC.

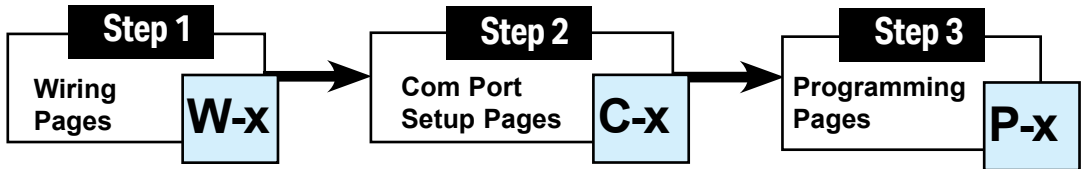

The following pages show the devices that you may connect to the CLICK PLC Com ports. Use the table below to locate information on communications for your particular application. As you can see in the table, each step has subcategories. For each step, find the subcategory description that best describes your application. Use the subcategory references (W-x, C-x, and P-x.) to find more information on these topics in this chapter. See the example below.

CLICK PLC Communications			
Step	Subcategory Reference	Subcategory Description	Page
Step 1 Wiring	W-1	Com port 1 & 2 (RS-232)	4-12
	W-2	Com port 1 (Ethernet)	4-17
	W-3	Com port 3 (RS-485)	4-20
Step 2 Com Port Setup	C-1	Com port 1 (RS-232) setup	4-21
	C-2	Com port 1 (Ethernet) setup	4-22
	C-3	Com port 2 setup (Modbus RTU)	4-23
	C-4	Com port 2 setup (ASCII)	4-24
	C-5	Com port 3 setup (Modbus RTU)	4-25
	C-6	Com port 3 setup (ASCII)	4-26
Step 3 Programming	P-1	Modbus Slave (Server) programming	4-27
	P-2	Modbus Master programming (Modbus RTU)	4-30
	P-3	Modbus Client programming (Modbus TCP)	4-32
	P-4	ASCII Receive programming	4-36
	P-5	ASCII Send programming	4-39

**Example:**

To connect a barcode reader that sends ASCII data to Com Port 2:

Refer to these three reference page sections.

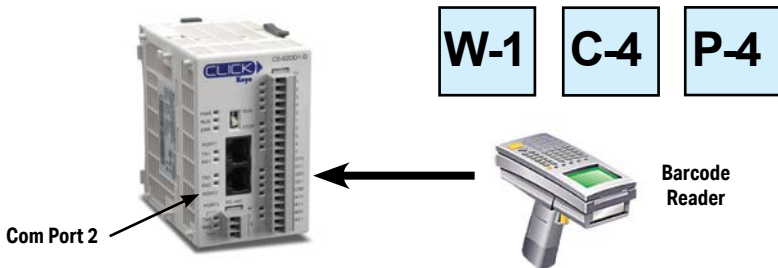

# Typical Communication Applications

The diagrams on the following four pages illustrate the typical uses for the CLICK PLC's communication ports. Typical serial communication applications are continued on the next three pages.

## Port 1 (RS-232) – Modbus RTU Slave Mode Only

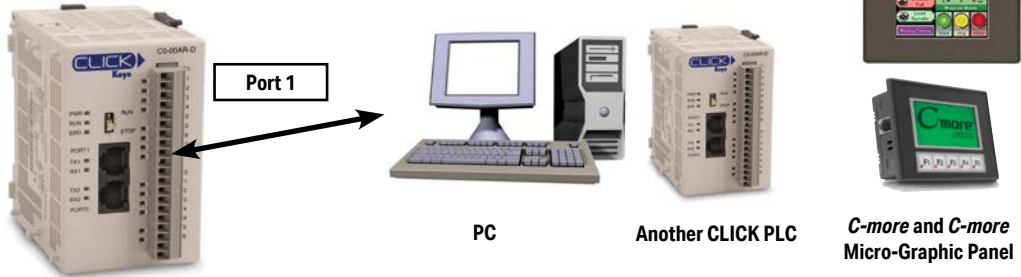

Basic, Standard and Analog PLCs

Other Devices Supporting Modbus RTU Master Mode

**W-1**   **C-1**   **P-1**



**TIP:** C-more Micro-Graphic panels (monochrome models only) can get 5 VDC power from RS-232 Port.

C-more Micro-Graphic Panel (Monochrome models only)

Example

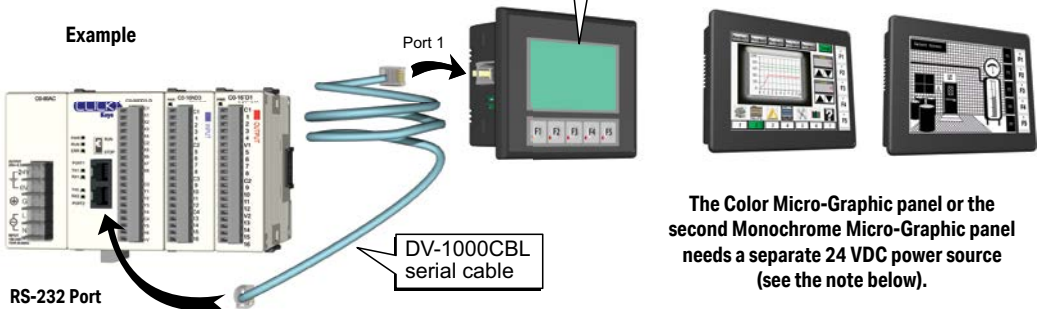

The Color Micro-Graphic panel or the second Monochrome Micro-Graphic panel needs a separate 24 VDC power source (see the note below).



**NOTE:** CLICK's RS-232 port can provide 5VDC to power one monochrome Micro-Graphic panel. If two C-more Micro-Graphic panels are connected to both ports, then at least one of the panels must be powered by a C-more Micro DC power adapter, EA-MG-P1 or EA-MG-SP1, or another 24VDC power source. Color C-more Micro-Graphic panels must also be powered from a separate 24VDC source.

Port 1 (Ethernet) – Modbus TCP

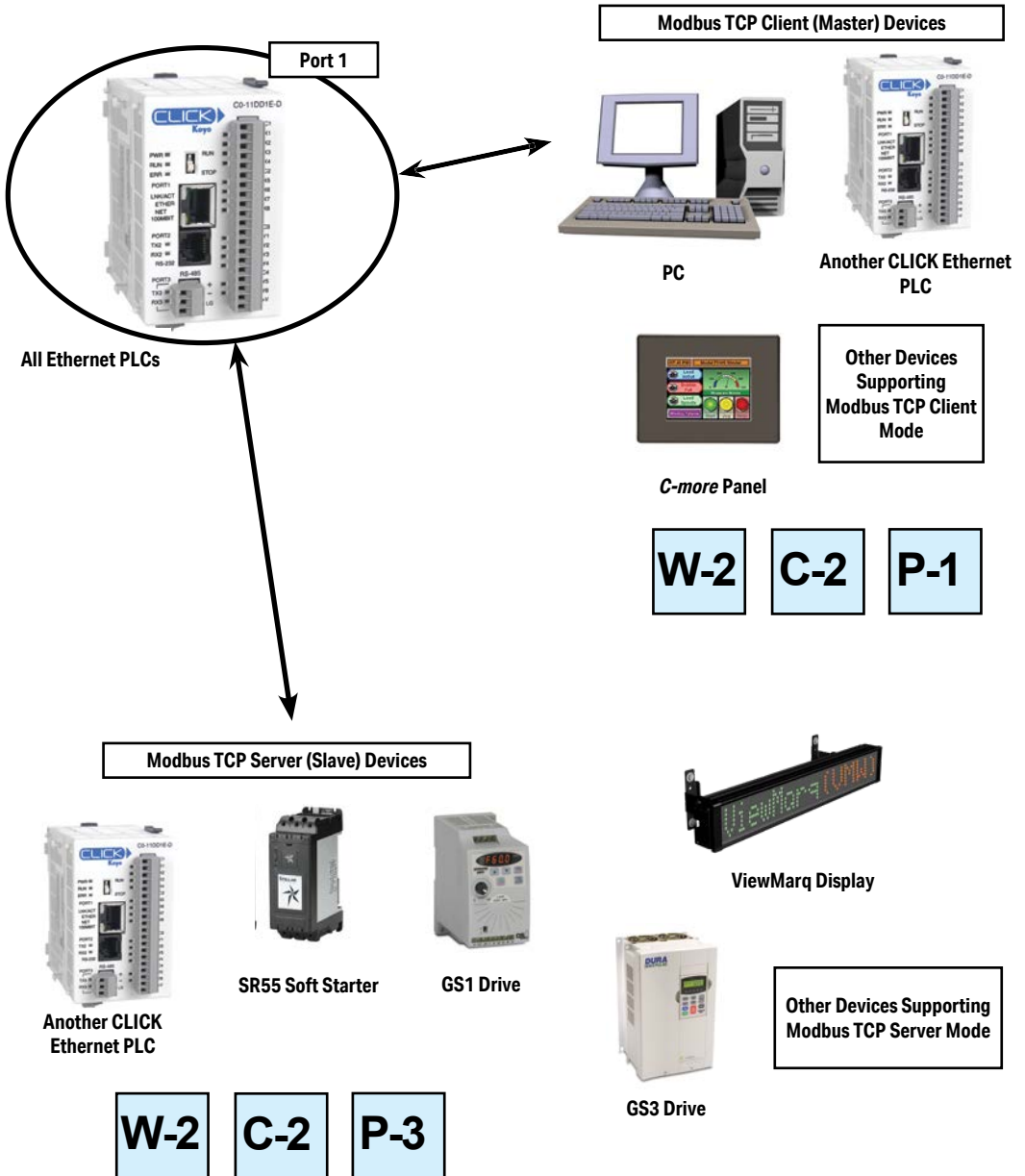

Port 2 (RS-232) – Modbus RTU or ASCII

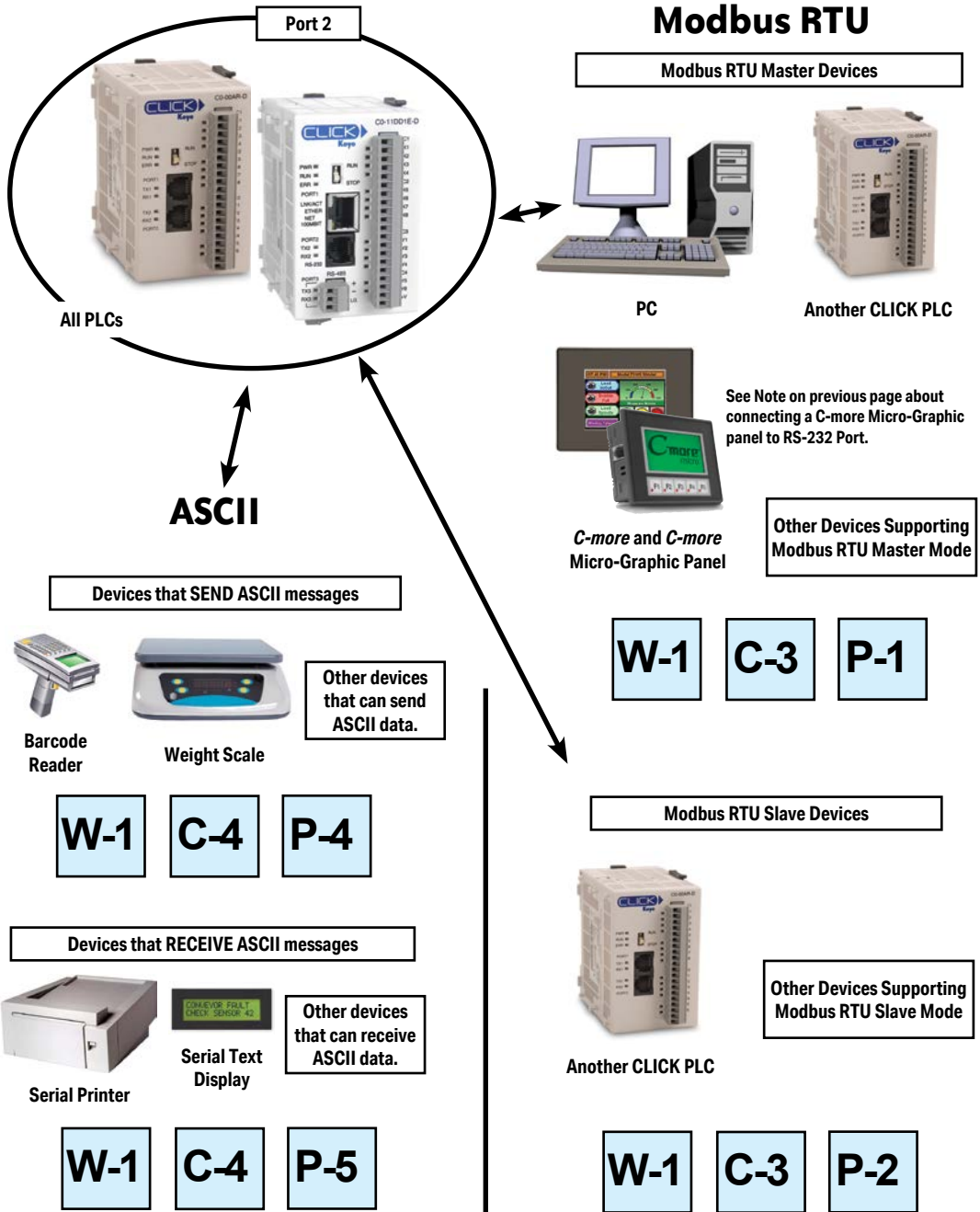

Port 3 (RS-485 – Modbus RTU or ASCII)

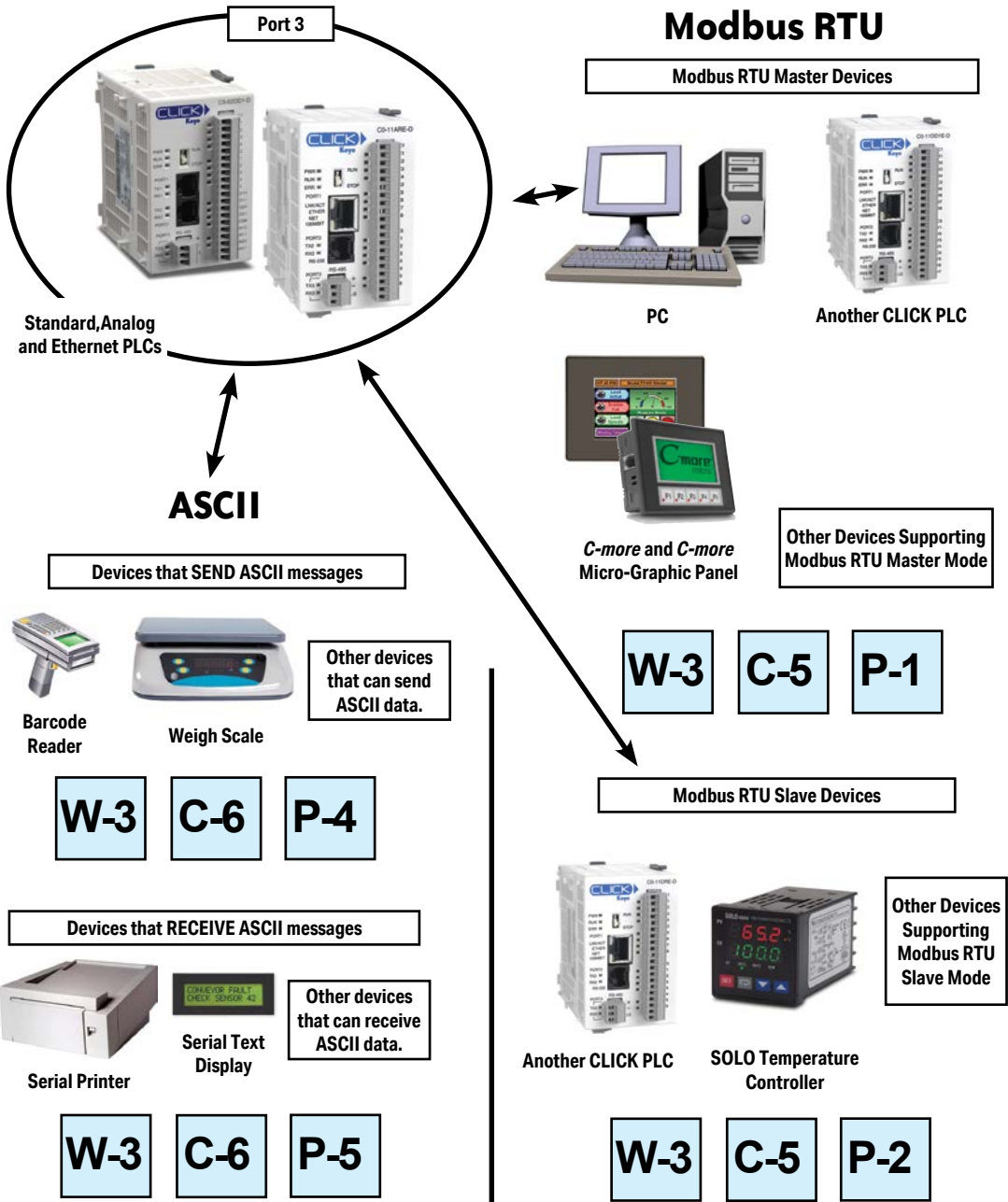

## W-1 W-1: Com Port 1 & 2 (RS-232) Wiring

Com Port 1 and Com Port 2 have very similar pin layouts; the only difference is that Port 2 has a RTS signal output, which Port 1 does not have.

6 pin RJ12 Phone Type Jack

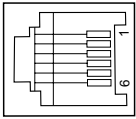

Port 1 Pin Descriptions		
1	0V	Power (-) connection (GND)
2	5V	Power (+) connection
3	RXD	Receive data (RS-232)
4	TXD	Transmit data (RS-232)
5	NC	No connection
6	0V	Power (-) connection (GND)

6 pin RJ12 Phone Type Jack

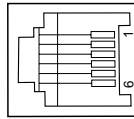

Port 2 Pin Descriptions		
1	0V	Power (-) connection (GND)
2	5V	Power (+) connection
3	RXD	Receive data (RS-232)
4	TXD	Transmit data (RS-232)
5	RTS	Request to send
6	0V	Power (-) connection (GND)



**NOTE:** Both Com ports can provide 5VDC; however, the 5VDC power can be used only for the C-more Micro-Graphic panel. AutomationDirect does not guarantee that the CLICK PLC will work correctly when any other device uses 5VDC from these Com ports. Please also remember these Com ports can provide enough power only for one C-more Micro-Graphic panel. If you are going to connect a C-more Micro-Graphic panel to each Com port (2 panels in total), you must obtain power from a separate 5VDC power source for the second C-more Micro-Graphic panel.

### Wiring Strategy

The following pages cover five case scenarios for connecting com ports 1 or 2:

Case 1: Connect Com Port 1 or 2 to a PC.

Case 2: Connect Com Port 1 or 2 to another CLICK PLC.

Case 3: Connect Com Port 2 to a C-more or C-more Micro-Graphic panel.

Case 4: Connect Com Port 2 to an RS-232 port on another device.

Case 5: Connect Com Port 1 or 2 to an RS-422 or RS485 port on another device(s).

**Case 1: Connect Com Port 1 or 2 to a PC.**

You can connect Com Port 1 or 2 to a serial com port or USB port on the PC.

**1. Connect to a serial port**

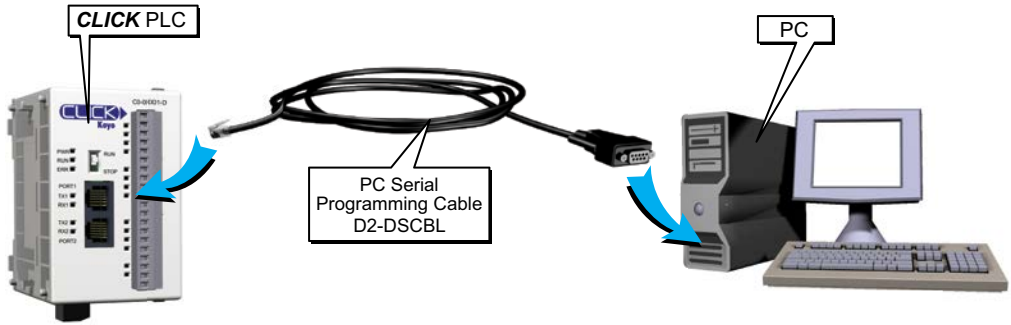

**2. Connect to a USB port**

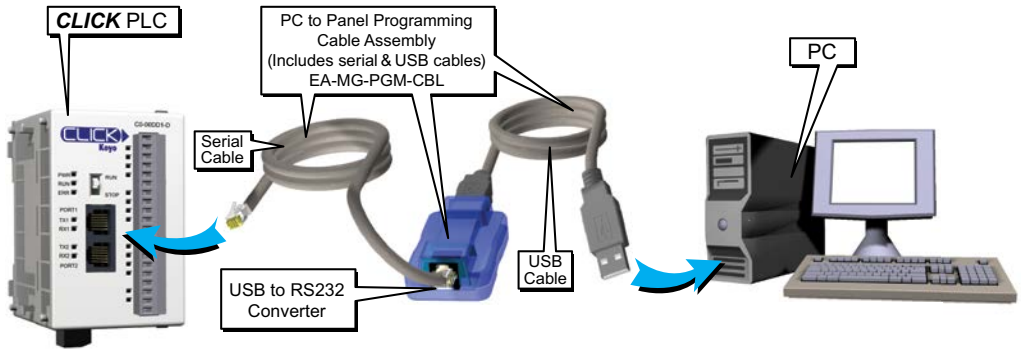

Case 2: Connect Com Port 1 or 2 to another CLICK PLC

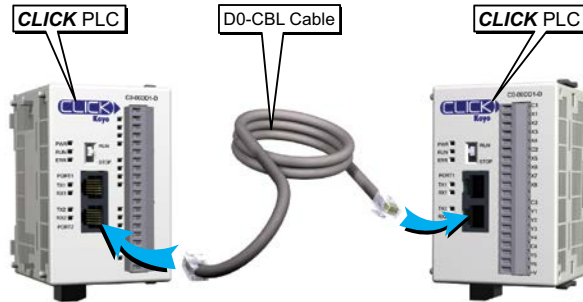

You can use cable D0-CBL.

In this configuration, one of the CLICK PLC units needs to be the network master and the other is the network slave. Connect the D0-CBL on Com Port 2 on the master PLC unit side.



**WARNING:** The ZL-RJ12-CBL-2 cable cannot be used for this purpose.

Case 3: Connect Com Port 1 or 2 to a C-more or C-more Micro-Graphic panel

Please use the following cables to make your connections.

C-more Graphic Panel	Cable Part Number
C-more Touch panels	EA-2CBL (3m) or OP-2CBL (2m)
C-more Micro-Graphic Panels	DV-1000CBL if the panel receives 5VDC power from the CLICK PLC com port. (Monochrome panels only; color panels must be powered from a separate 24VDC power source. Please refer to the note on page 4-6 for details.)
	EA-2CBL (3m) or OP-2CBL (2m) if the panel receives 24VDC power from other source.

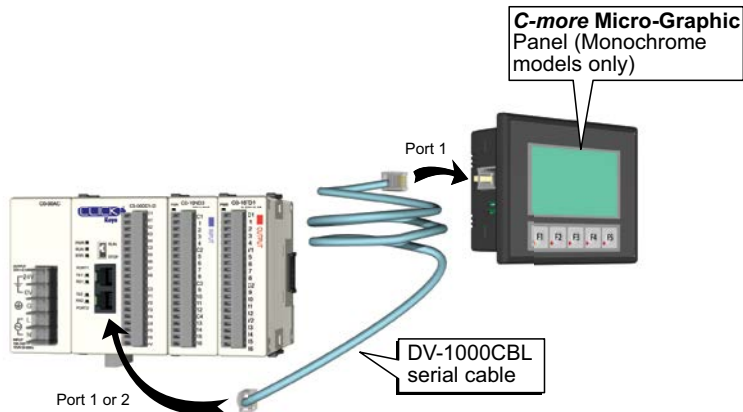

**Case 4: Connect Com Port 1 or 2 to an RS-232 port on another device**

You need to cross the RTD and TXD signal lines and connect 0V on both com ports.

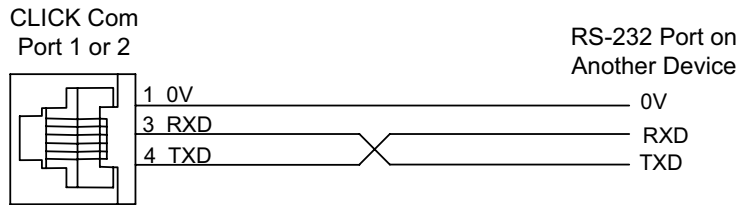

You can make your own cable. However, we offer two products that make your wiring much easier:

1. ZIPLink feed-through module and cable

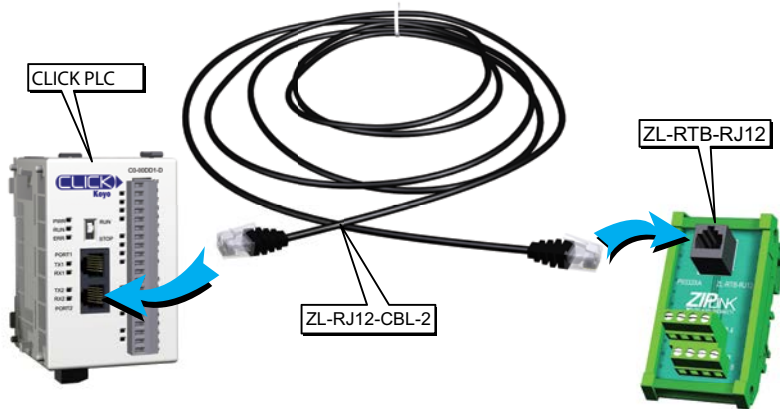

2. ZIPLink pig-tail cable

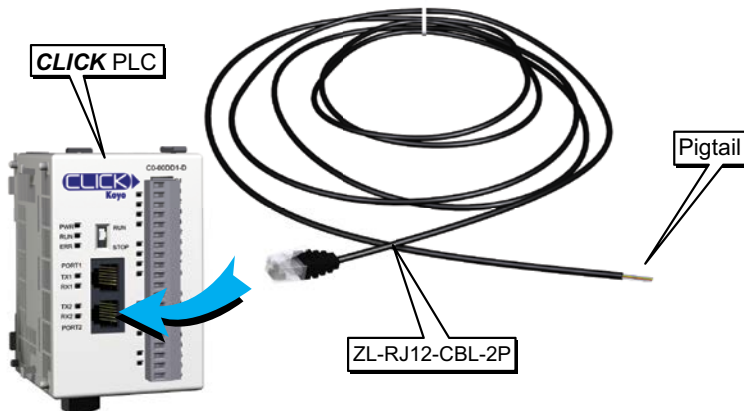

### Case 5: Connect Com Port 1 or 2 to an RS-422 or RS485 port on another device(s).

You need a RS-232 to RS-422/485 converter in this case. We recommend our FA-ISOCOCON as the converter.

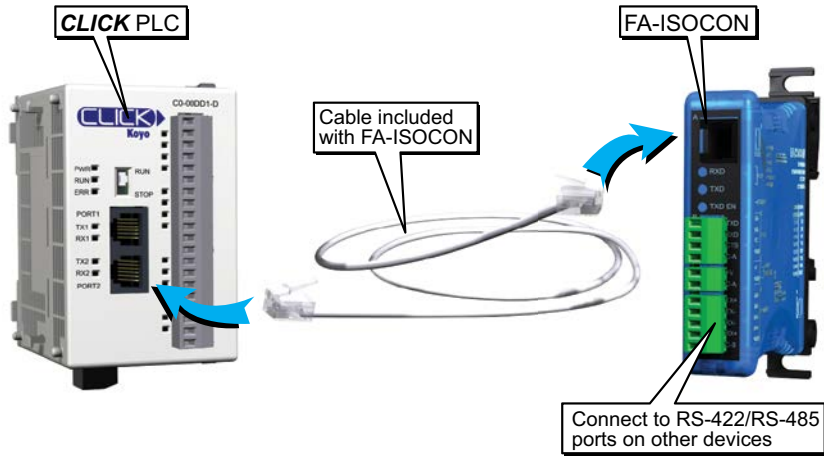

The recommended cables to connect the FA-ISOCOCON to other devices:

- Belden 8103 for the RS-422
- Belden 9842 for 2-wire RS-485
- Belden 9843 for 4-wire RS-485

## W-2 W-2: Com Port 1 (Ethernet) Wiring

Com Port 1 (Ethernet) supports 10/100 Base-T Ethernet with an RJ-45 style connector.

8 pin RJ45 Phone  
Type Jack

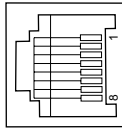

Port 1 Pin Descriptions	
1	TX+ Transmit Data (+)
2	TX- Transmit Data (-)
3	RX+ Receive data (+)
4	NC Not connected
5	NC Not connected
6	RX- Receive Data (-)
7	NC No connection
8	NC No connection

You can use both straight and cross over cables with Com Port 1.

### Wiring Strategy

- There are two wiring methods to connect to devices which support Modbus TCP protocol.
- Case 1: Connect Com Port 1 to a device that supports Modbus TCP protocol directly such as a PC.
- Case 2: Connect Com Port 1 to other devices that support the Modbus TCP protocol via a switch or hub.

### Case 1: Connect Com Port 1 to a device that supports the Modbus TCP protocol directly such as a PC.

In this illustration an Ethernet PLC unit is connected directly to a PC.

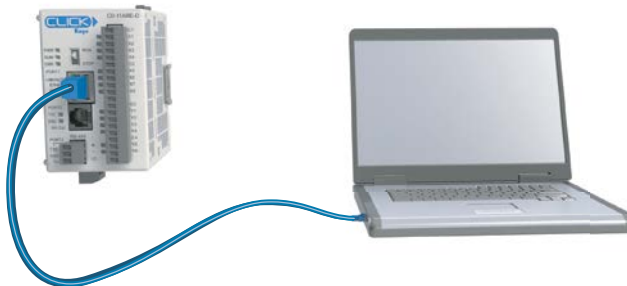

### Case 2: Connect Com Port 1 to other devices that support the Modbus TCP (client/server) protocol via a switch or hub.

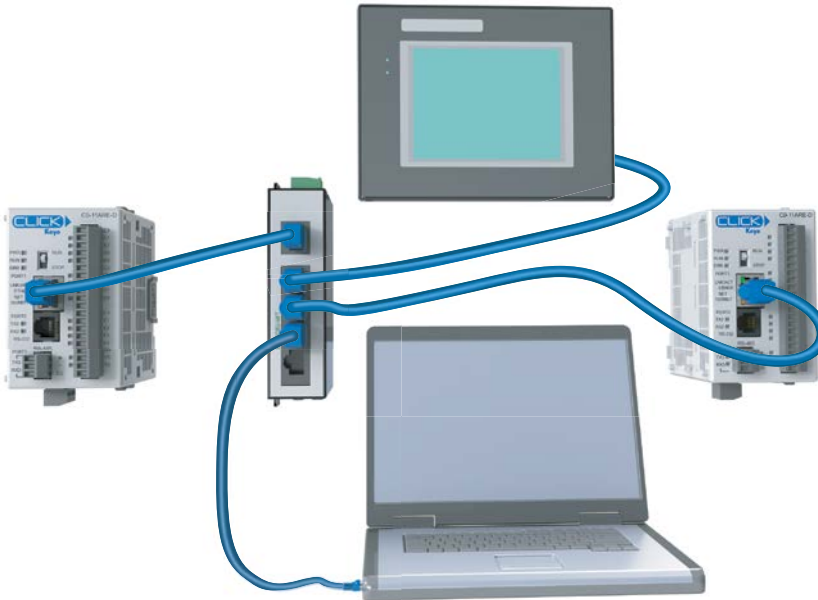

---

**NOTE:** Com Port 1 can communicate with any number of servers (slaves) using the Receive and/or Send instructions. However, Com Port 1 can communicate with up to 4 servers at the same time. If the ladder program has sent a message to 4 different servers and tries to send a message to another server, the CLICK PLC unit disconnects the first server and establishes a connection with the new server, maintaining a total of 4 servers.

---



---

**NOTE:** Com Port 1 can communicate with up to 3 clients (masters). If a client attempts to establish communication with Com Port 1 while it is communicating with 3 clients, the CLICK PLC unit replies with an error to the forth client.

---

## W-3 W-3: Com Port 3 Wiring

Com Port 3 supports 2-wire RS-485.

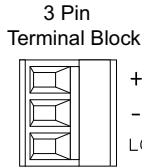

Port 3 Pin Descriptions		
1	+ (Plus)	Signal A (RS-485)
2	- (Minus)	Signal B (RS-485)
3	LG	Logic Ground (0 V)

### Wiring Strategy

You need to connect all + signal terminals in the network together. You will also need to connect all – signal terminals together. It is optional to connect the logic ground.

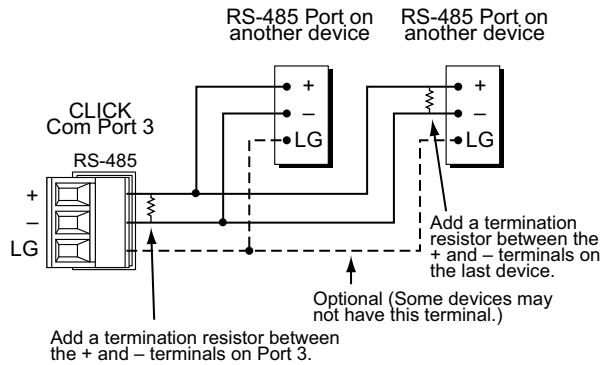

**NOTE:** The resistance of the termination resistors needs to match the impedance of the communication cable.



**NOTE:** Use a repeater if connecting more than 32 slaves to Port 3.

C-1

### C-1: Com Port 1 (RS-232) Setup

Com Port 1 has a fixed setup as shown below. This com port works as a Modbus RTU slave only. If you want to connect an external device to this com port, please make sure the external device can be a Modbus RTU master and that the com port setup matches the following setup.

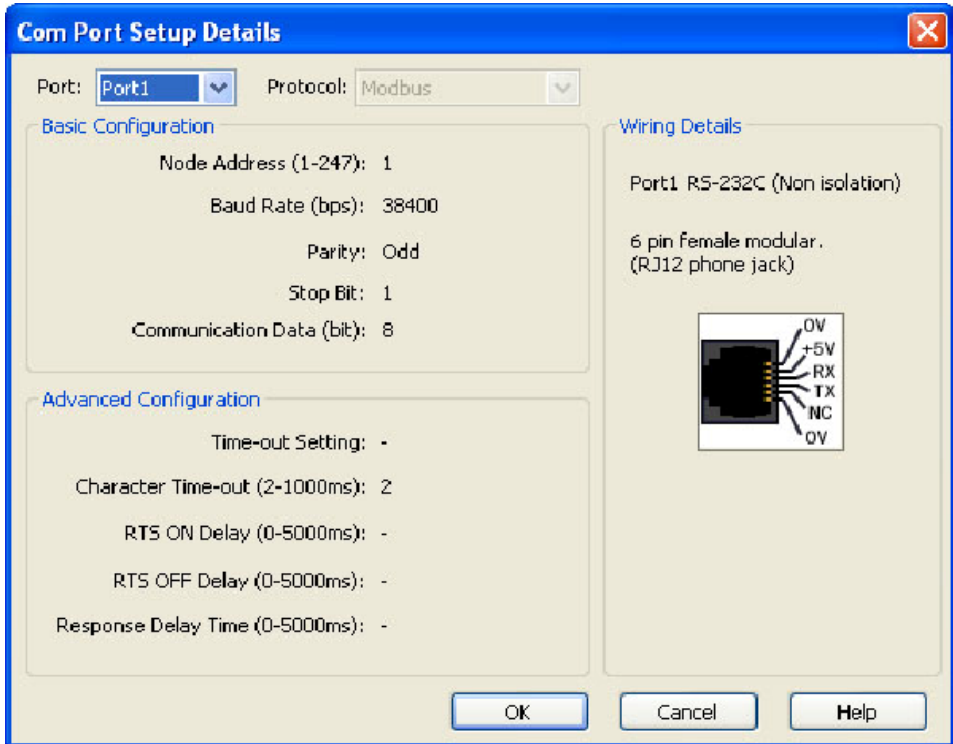

## C-2 C-2: Com Port 1 (Ethernet) Setup

### Wiring Strategy

Before you set up this communication port, you must connect a PC loaded with CLICK programming software to the CLICK PLC Port 1 using an Ethernet cable or to the CLICK PLC Port 2 using a D2-DSCBL or EA-MG-PGM-CBL programming cable. Refer to Chapter 1: *Getting Started* for step-by-step instructions on this connection. Once the PC and programming software are online with the CLICK PLC, select the **Function** tab located in the Navigation window and double click “Com Port 1 Setup” as shown below.

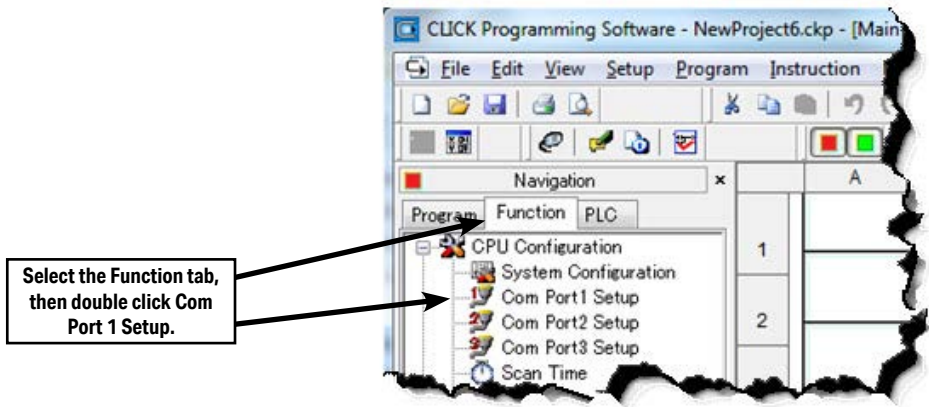

The Com Port Setup Details dialog box will come into view as shown below

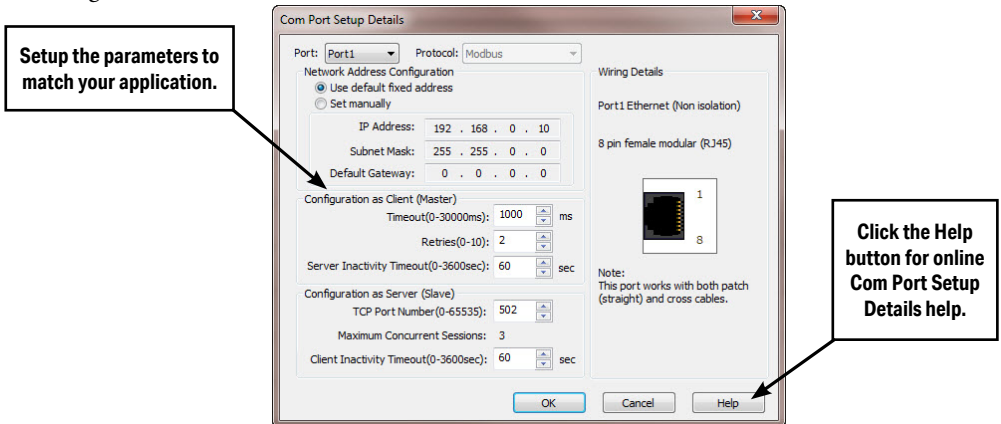

**NOTE:** The communication port settings are saved in the project file. The project must be transferred to the CLICK PLC in order for any port setting changes to take effect.

**C-3**

**C-3: Com Port 2 Setup (Modbus RTU)**

Before you set up the communication ports you must connect the PC with the CLICK PLC Port 1 using a D2-DSCBL or EA-MG-PGM-CBL programming cable. Refer to Chapter 1: Getting Started for step-by-step instructions for this connection. Once the PC and programming software are online with the CLICK PLC, click the Function tab located in the Navigation window and double click **Com Port2 Setup** as shown below.

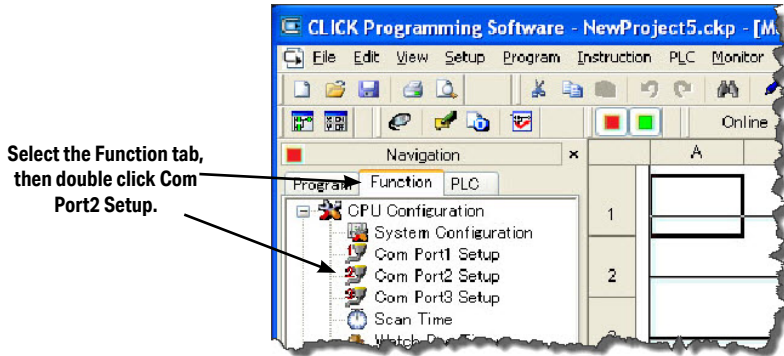

The Com Port Setup Details dialog box will come into view as shown below.

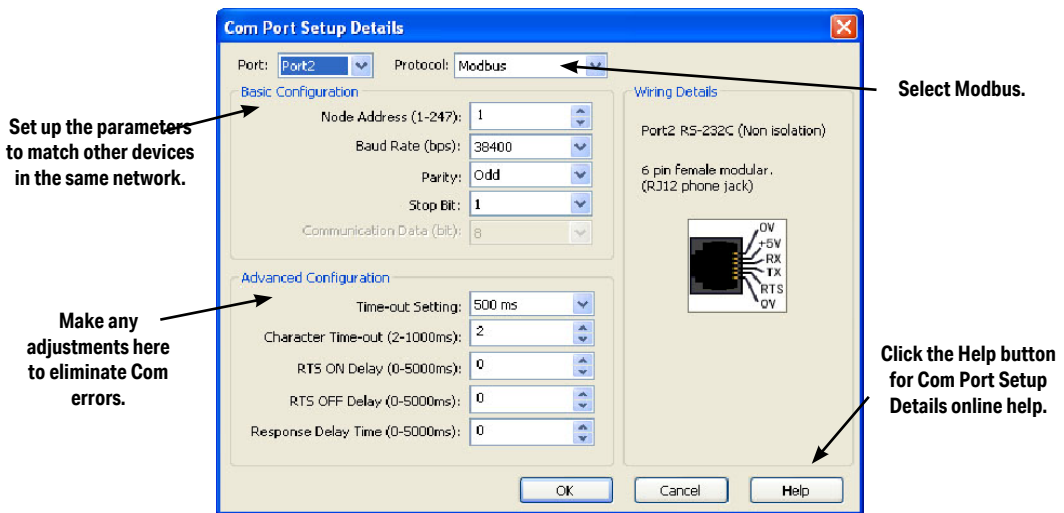

Find the Basic Configuration section in the dialog box and set up the parameters to match other devices in the same network. The dialog box also has a section named Advanced Configuration. You may need to make adjustments to these parameters to overcome communication errors which may occur.

**TIP:** The communication port settings are saved in the project file. The project must be transferred to the CLICK PLC in order for any port setting changes to take effect.



## C-4 C-4: Com Port 2 Setup (ASCII)

Before you set up the communication ports you must connect the PC with the CLICK PLC Port 1 using a D2-DSCBL or EA-MG-PGM-CBL programming cable. Refer to Chapter 1: Getting Started for step-by-step instructions for this connection. Once the PC and programming software are online with the CLICK PLC, click the Function tab located in the Navigation window and double click **Com Port2 Setup** as shown below.

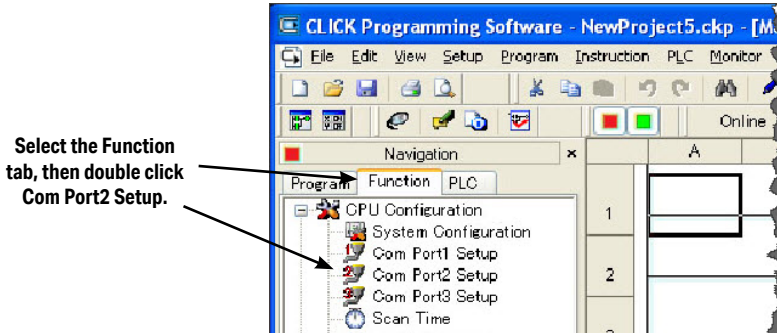

The Com Port Setup Details dialog box will come into view as shown below.

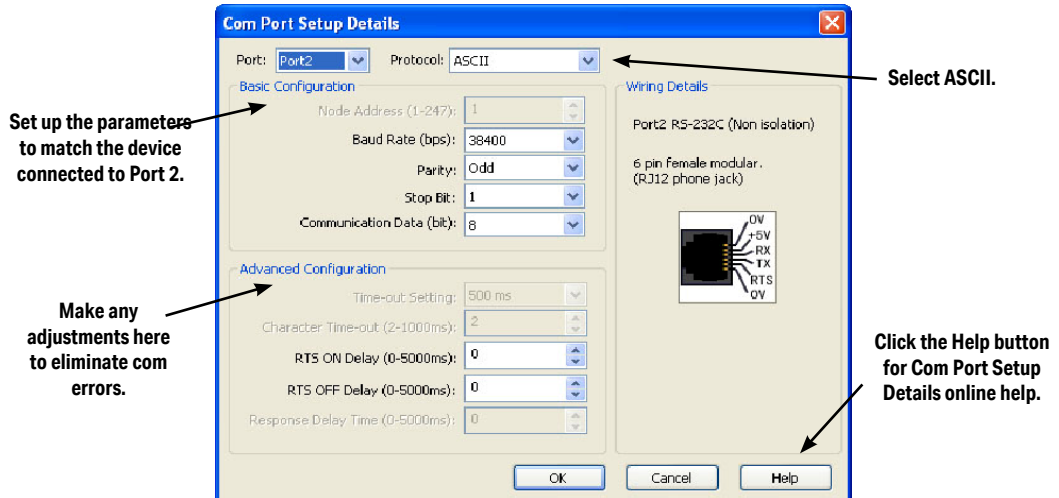

Find the Basic Configuration section in the dialog box and set up the parameters to match the device connected to Port 2. The dialog box also has a section named Advanced Configuration. You may need to make adjustments to these parameters to overcome communication errors which may occur.



**TIP:** The communication port settings are saved in the project file. The project must be transferred to the CLICK PLC in order for any port setting changes to take effect.

## C-5 C-5: Com Port 3 Setup (Modbus RTU)

Before you set up the communication ports you must connect the PC with the CLICK programming software to the CLICK PLC Port 1 using a D2-DSCBL or EA-MG-PGM-CBL programming cable. Refer to Chapter 1: Getting Started for step-by-step instructions for this connection. Once the PC and programming software are online with the CLICK PLC, click the Function tab located in the Navigation window and double click **Com Port3 Setup** as shown below.

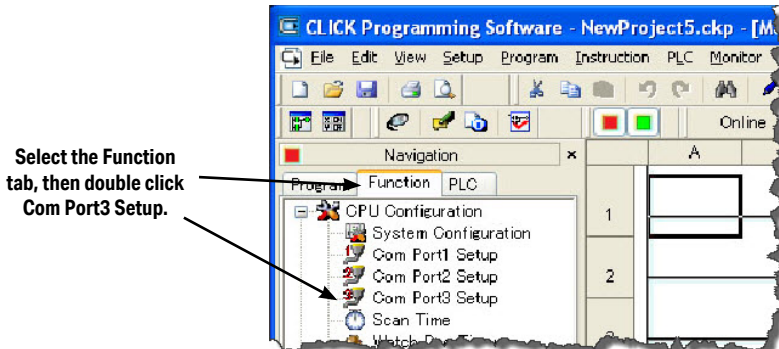

The Com Port Setup Details dialog box will come into view as shown below.

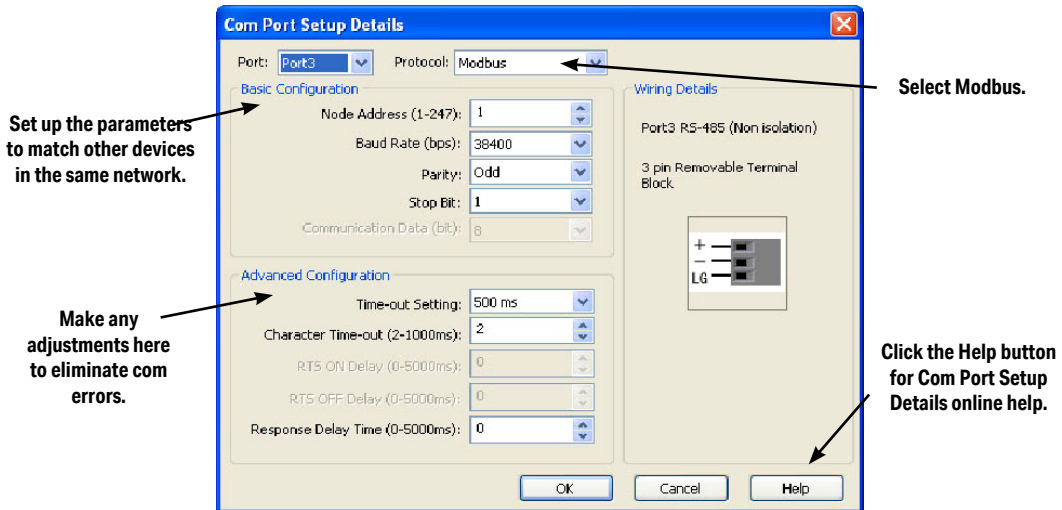

Find the Basic Configuration section in the dialog box and set up the parameters to match other devices in the same network. The dialog box also has a section named Advanced Configuration. You may need to make adjustments to these parameters to overcome communication errors which may occur.



**TIP:** The communication port settings are saved in the project file. The project must be transferred to the CLICK PLC in order for any port setting changes to take effect.

## C-6 C-6: Com Port 3 Setup (ASCII)

Before you set up the communication ports you must connect the PC with the CLICK PLC Port 1 using a D2-DSCBL or EA-MG-PGM-CBL programming cable. Refer to Chapter 1: Getting Started for step-by-step instructions for this connection. Once the PC and programming software are online with the CLICK PLC, click the Function tab located in the Navigation window and double click **Com Port3 Setup** as shown below.

The Com Port Setup Details dialog box will come into view as shown below.

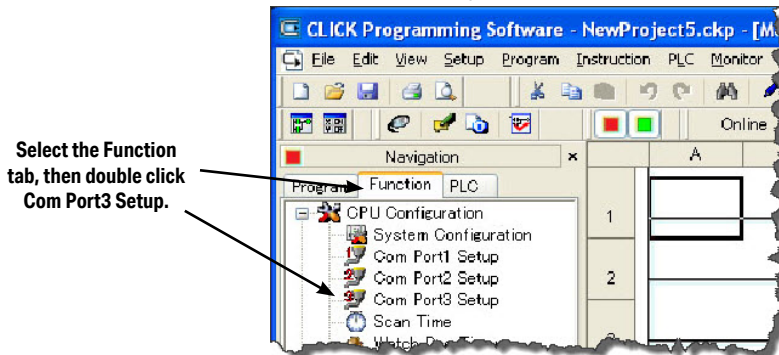

Find the Basic Configuration section in the dialog box and set up the parameters to match the device connected to Port 3.

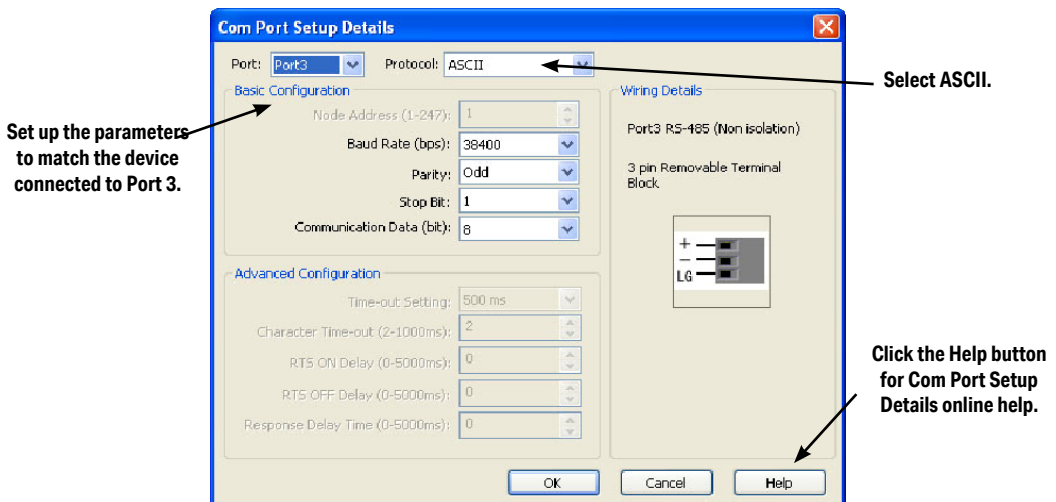

**TIP:** The communication port settings are saved in the project file. The project must be transferred to the CLICK PLC in order for any port setting changes to take effect.

# P-1 P-1: Modbus Slave (Server) Programming

## Ladder Program

To use a CLICK PLC as a Modbus slave (server), you don't need any special ladder program. Set up the communication port properly and you just need an End instruction in the ladder program to put the PLC in Run mode.



However, you can add any additional ladder program to let the slave CLICK PLC control something by itself. For instance, you may want to shut down the outputs on the slave (server) CLICK PLC should it lose communication with the Modbus master (client).



**NOTE:** The Modbus master can communicate with the Modbus slave CLICK PLC without any ladder program. However, output points on the Modbus slave CLICK PLC cannot be turned on if the PLC is not in the Run mode. Because of this, we recommend having at least one End instruction and to put the PLC in Run mode.

## Lost Communication Situation

You may want to detect if there is something happening at the Modbus master side that stops communication with the Modbus slaves. Or, the communication cable might have been disconnected. In this situation, you may want the Modbus slaves to take an action. For instance, you may want to shut down the outputs on the slave CLICK PLC when the communication with the Modbus master is lost. We offer an easy method to accomplish this.

The CLICK keeps counting how long it has been since each com port received a message from the Modbus master, and enters the time duration in the following system data registers.

System Data Registers		
System Data Register	Nickname	Range
SD41	_Port1_No_Comm_Time	0 - 32767 (sec)
SD51	_Port2_No_Comm_Time	0 - 32767 (sec)
SD61	_Port3_No_Comm_Time	0 - 32767 (sec)

Each register is reset to zero automatically when the com port receives a message from the Modbus master. Then its value increments by 1 per second until the com port receives another message from the Modbus master. If one of these registers has 60 as its value, it means the com port has not received any message from the Modbus master for 60 seconds. You can use this info to shut down the outputs on the slave CLICK PLC. Here is an example program.

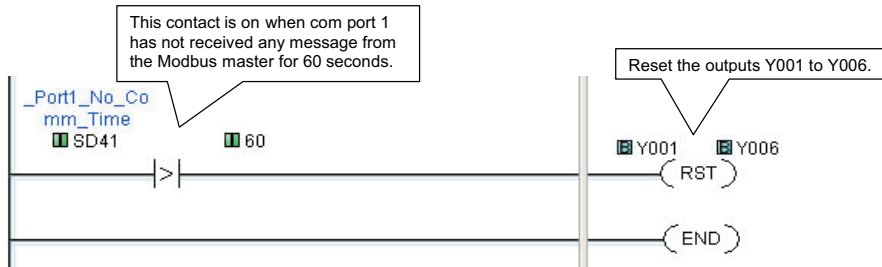

## Modbus Addressing

Each of the memory addresses in the CLICK (X1, DS1, etc.) has a unique Modbus address. This means the network master in the Modbus network can access any memory address in the slave CLICK PLC. The best way to check which Modbus address is assigned to a particular CLICK memory address is to use the CLICK programming software.

Click the Program tab located in the Navigation window and double click Address Picker as shown below.

After the Address Picker window opens, check the option Display MODBUS Address on the right bottom.

Select the Program tab, then double click Address Picker.

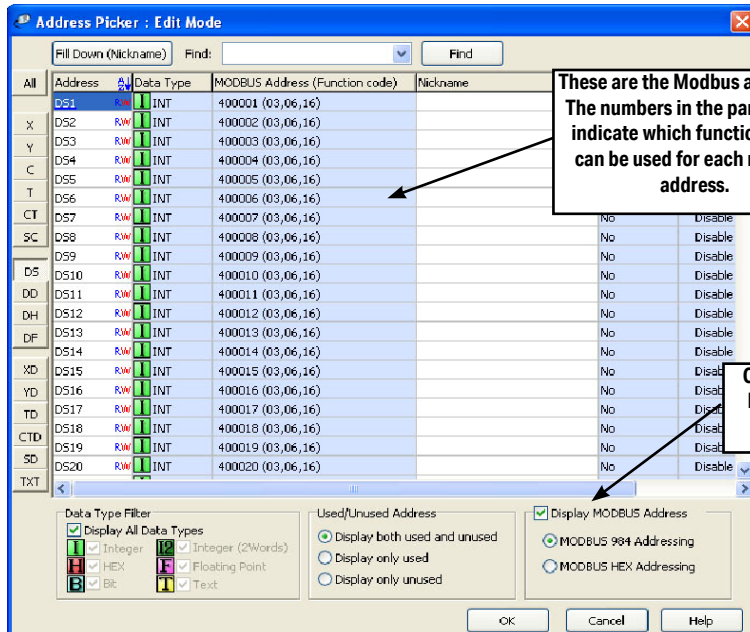

These are the Modbus addresses. The numbers in the parenthesis indicate which function codes can be used for each memory address.

Check the option Display Modbus Address.

### Exception Response (Exception Code)

When the slave CLICK PLC receives a request from the Modbus master that it cannot respond to, the slave CLICK PLC sends an exception response to the Modbus master. The CLICK PLC supports the following Exception Responses.

Exception Response (Exception Code)		
Code	Name	Details of Exception Response
01	Illegal Function	The CLICK PLC does not support the function code received from the MODBUS master.
02	Illegal Data Address	The MODBUS master tried to access to an invalid address.
03	Illegal Data Value	The data length is zero or exceeds the maximum size.
		The data for Write Single Coil is not FF00h (ON) or 0000h (OFF).
		The PLC mode change request from the MODBUS master is not valid.
04	Slave Device Failure	Password is locked.
		When the PLC mode switch is in STOP position, the MODBUS master requested to switch to RUN mode.
		When the PLC mode switch is in RUN position, the MODBUS master requested to switch to the Firmware Update mode.

## P-2 P-2: Modbus Master Programming (Modbus RTU)

### Instructions

The CLICK PLC has two instructions to exchange data with external Modbus devices through the com ports; the Receive and Send instructions.

- Receive instruction: Read data from an external Modbus device.
- Send instruction: Write data to external Modbus device(s).

To use these instructions, double click Receive or Send in the Instruction List window as shown below.

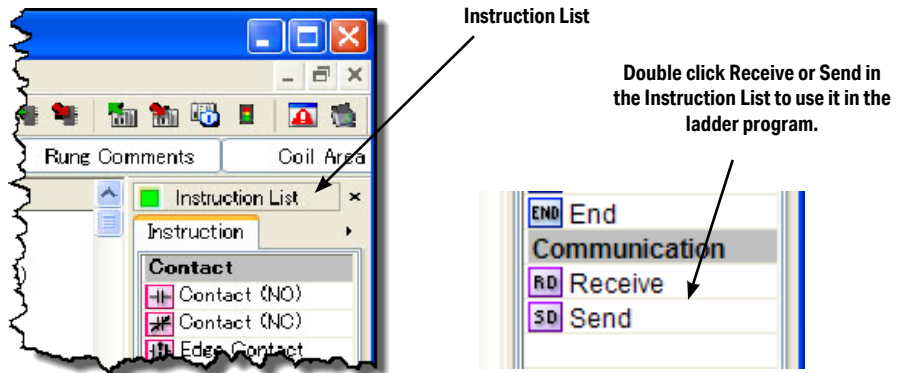

Select the Com Port that you are going to use and confirm the Protocol is MODBUS.

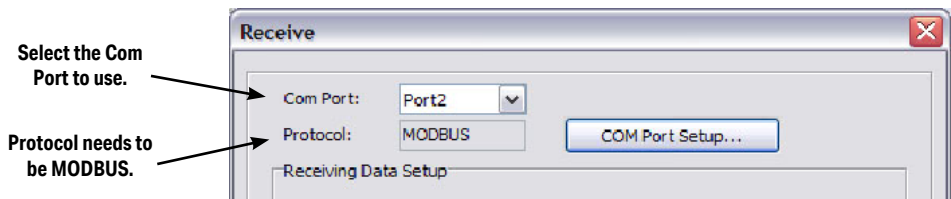

If the Protocol is not MODBUS, click the Com Port Setup button to open the Com Port Setup Details window and change the Protocol to MODBUS. If the Protocol selection is grayed out as shown below, it means the Com Port is used by another Receive and/or Send instruction in the ladder program. You cannot change the Protocol setup until you delete those instructions.



## Chapter 4: PLC Communications

When you open the Receive or Send instruction in the Modbus mode, their windows should look like this. For the explanation of each setup parameter, please click the Help button on the bottom right.

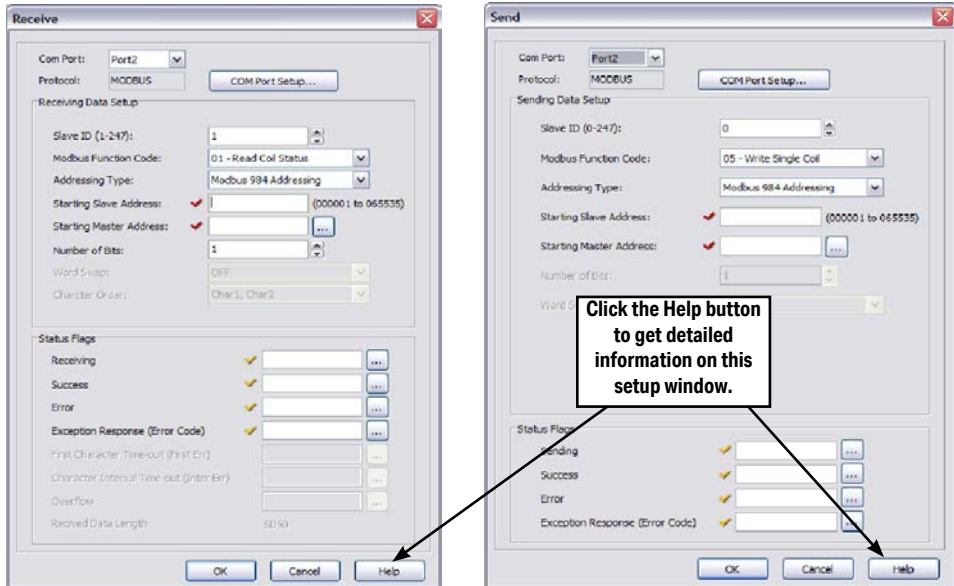

### Com Port Status Indicators

The CLICK PLC has the following System Control Relays to indicate the status of the Com Ports. If monitoring these bits in ladder, they should be monitored at a ladder location prior to the Receive or Send instructions for the port. w

System Control Relays		
Address	Nickname	Description
SC100	<u>Port_2_Ready_Flag</u>	On when Port 2 is ready.
SC101*	<u>Port_2_Error_Flag</u>	On when Port 2 has a communication error.
SC102	<u>Port_3_Ready_Flag</u>	On when Port 3 is ready.
SC103*	<u>Port_3_Error_Flag</u>	On when Port 3 has a communication error.

\* Errors that will cause SC101 or SC103 error flag to turn on:

- Parity Error
- Frame Error
- Time Out
- CRC Error
- Modbus Exception Response

### Example Program

The ladder program to use these Receive and Send instructions are easy. You just need one NO (Normally Open) contact instruction to check if the com port is ready to receive or send data.

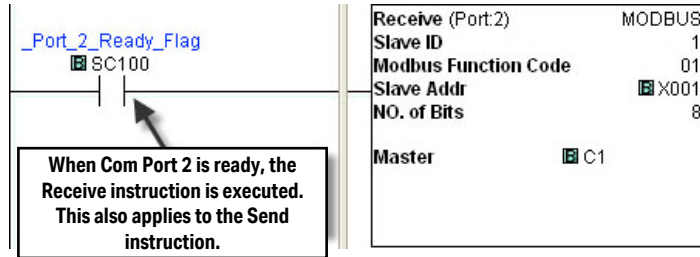

### Interlocking

If you are going to use more than one Receive and/or Send instruction with a serial communication port, you need to be sure only one of the instructions is enabled at any point during the operation. The technique to execute more than one Receive and/or Send instructions in order is called 'Interlocking'. When the Interlocking sample program below is executed, the two Receive instructions and two Send instructions are executed one by one.

### Example Program: Interlocking with Two Slaves

In this example, Port 3 on the CLICK PLC unit communicates with two MODBUS slaves. The slave IDs (node numbers) are 1 and 2. The CLICK PLC unit executes one Receive instruction and one Send instruction with each MODBUS slave.

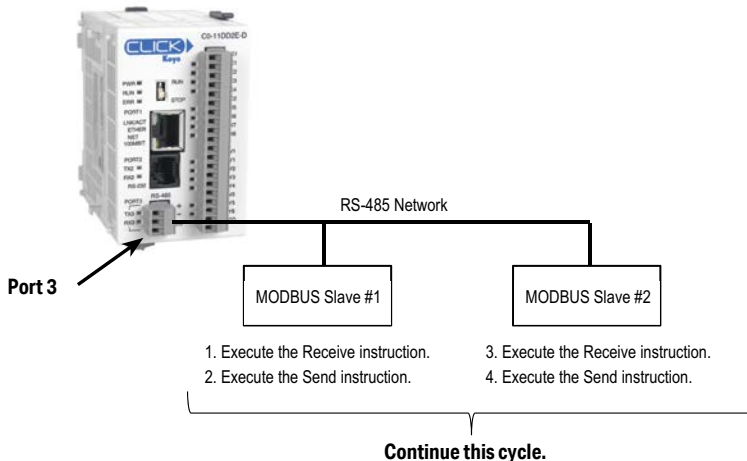

## Example Program: Interlocking with Two Slaves (Continued)

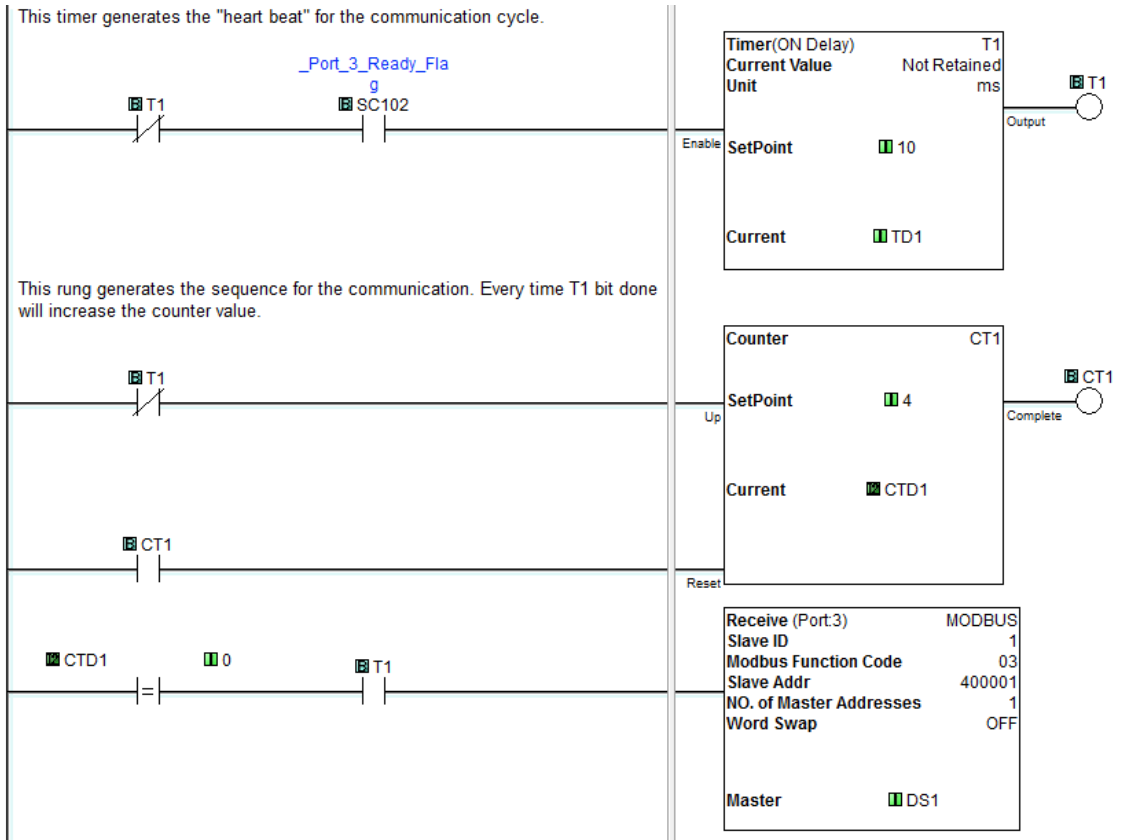

Example Program: Interlocking with Two Slaves (Continued)

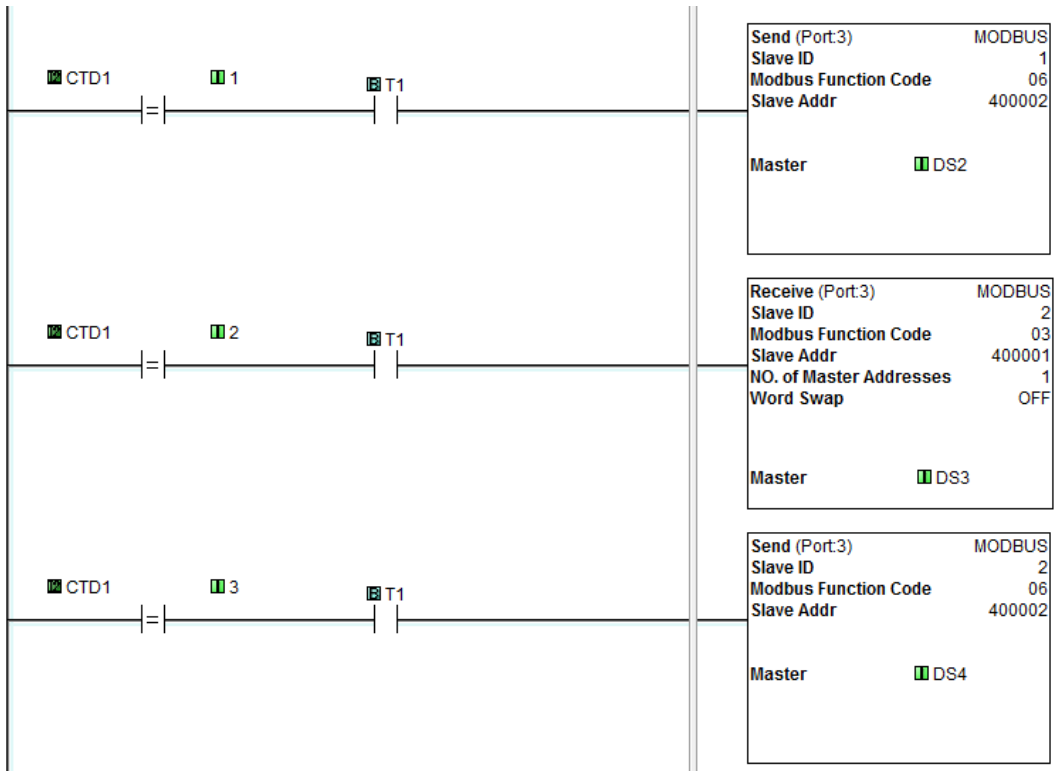

## P-3 P-3: Modbus Client (Modbus TCP) Programming

### Instructions

The CLICK PLC has two instructions to exchange data with Modbus servers through the Com Port 1; the Receive and Send instructions.

- **Receive** instruction: Read data from external Modbus server.
- **Send** instruction: Write data to external Modbus server(s).

To use these instructions, double click Receive or Send in the Instruction List window as shown below.

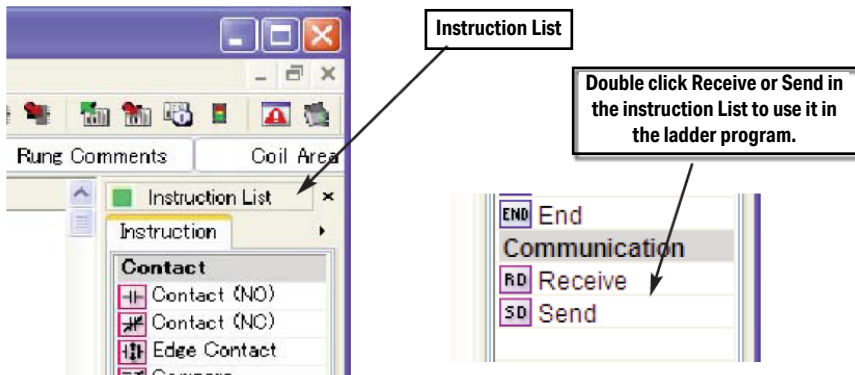

Select Com Port 1 that you are going to use.

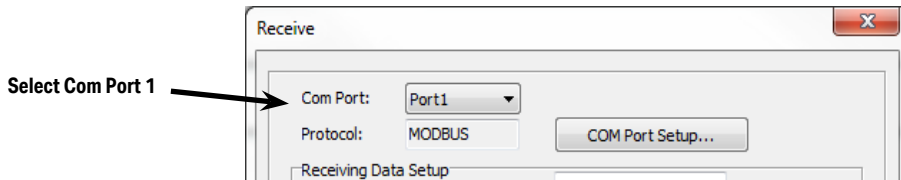

When you open the Receive or Send instruction in the Modbus mode, their windows should look like this. For the explanation of each setup parameter, please click the Help button on the bottom right.

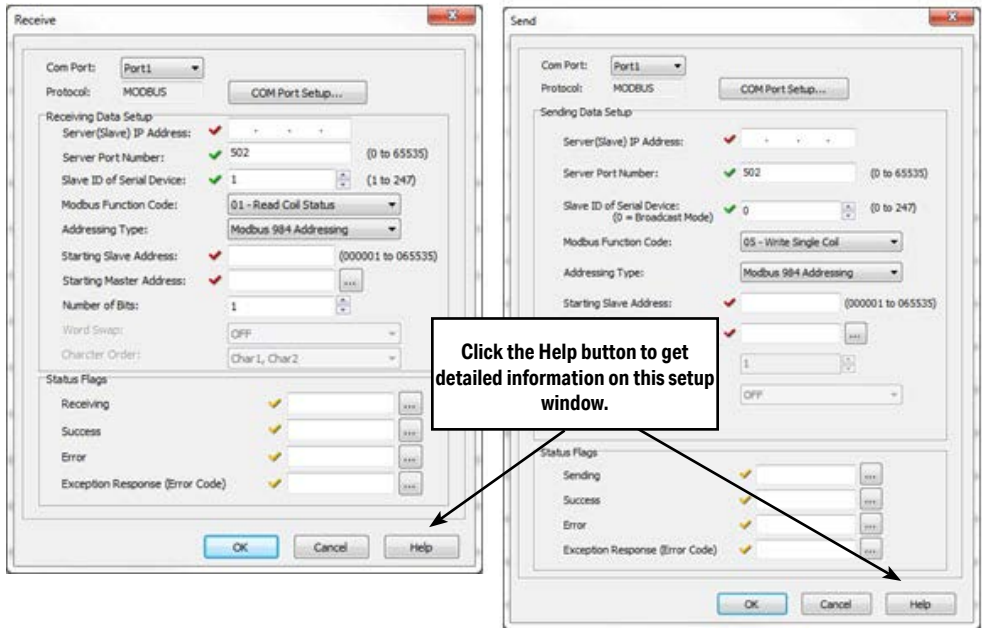

### Com Port Status Indicators

The CLICK PLC has the following System Control Relays to indicate the status of Com Port 1.

System Control Relays		
Address	Nickname	Description
SC90	_Port_1_Ready_Flag	ON when Port 1 is ready.
SC91	_Port_1_Error_Flag	ON when Port 1 has a communication error.
SC92	_Port_1_Clients_Limit	ON when Port 1 is communicating with 3 clients.
SC93	_Port_1_IP_Resolved	ON when Port 1 obtains an IP address.
SC94	_Port_1_Link_Flag	ON when Port 1 is connected to an Ethernet network.
SC95	_Port_1_100MBIT_Flag	ON when Port 1 is communicating at 100Mbps.

### Example Program

The ladder program to use these Receive and Send instructions are easy. You just need one NO (Normally Open) contact instruction to check if the com port is ready to receive or send data.

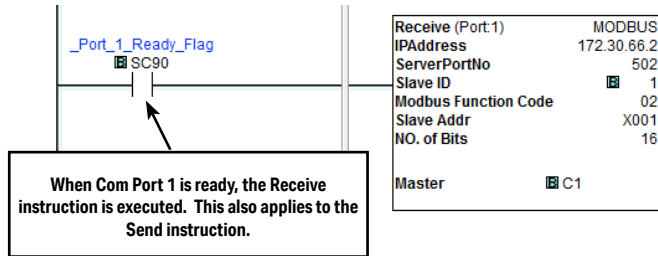

## Interlocking

If you are going to use more than one Receive and/or Send instruction with the same server(slave), you need to be sure only one of the instructions is enabled at any point during the operation. The technique to execute more than one Receive and/or Send instructions in order is called 'Interlocking'. When the Interlocking sample program below is executed, one Receive instruction and one Send instruction is executed one-by-one for each server.

### Example Program: Interlocking with Two Servers

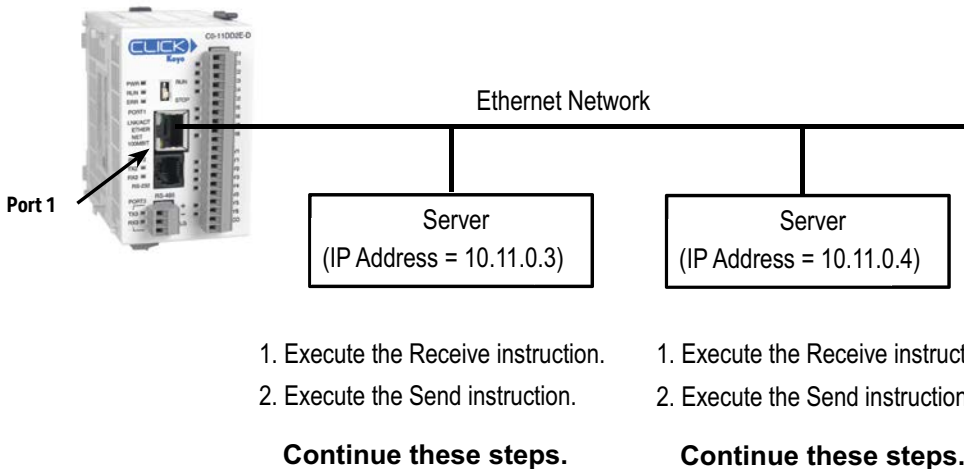

**NOTE:** Port 1 can establish the connection with up to 4 servers at the same time.

## Example Program: Interlocking with a Server (Continued)

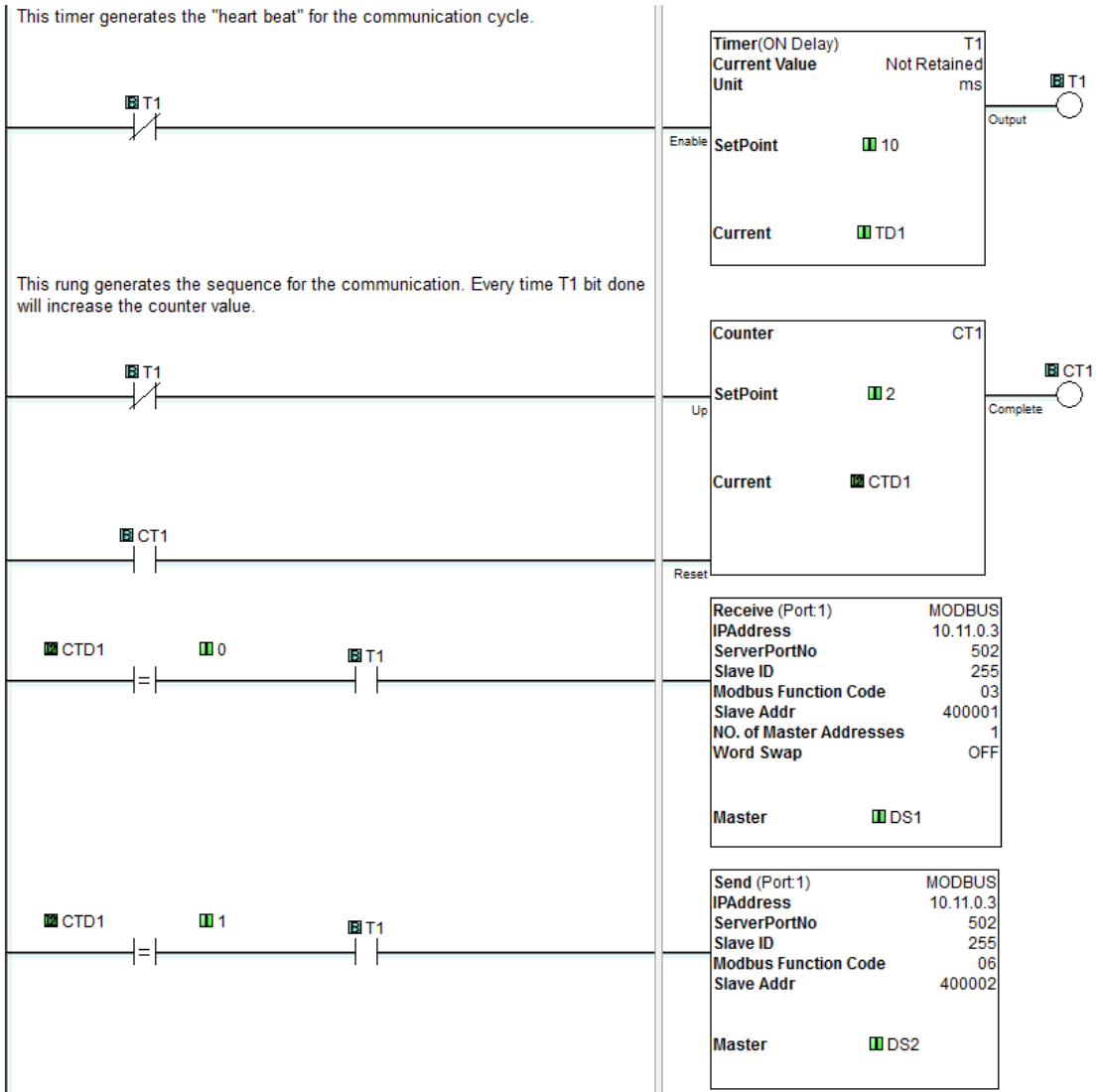

Example Program: Interlocking with a Server (Continued)

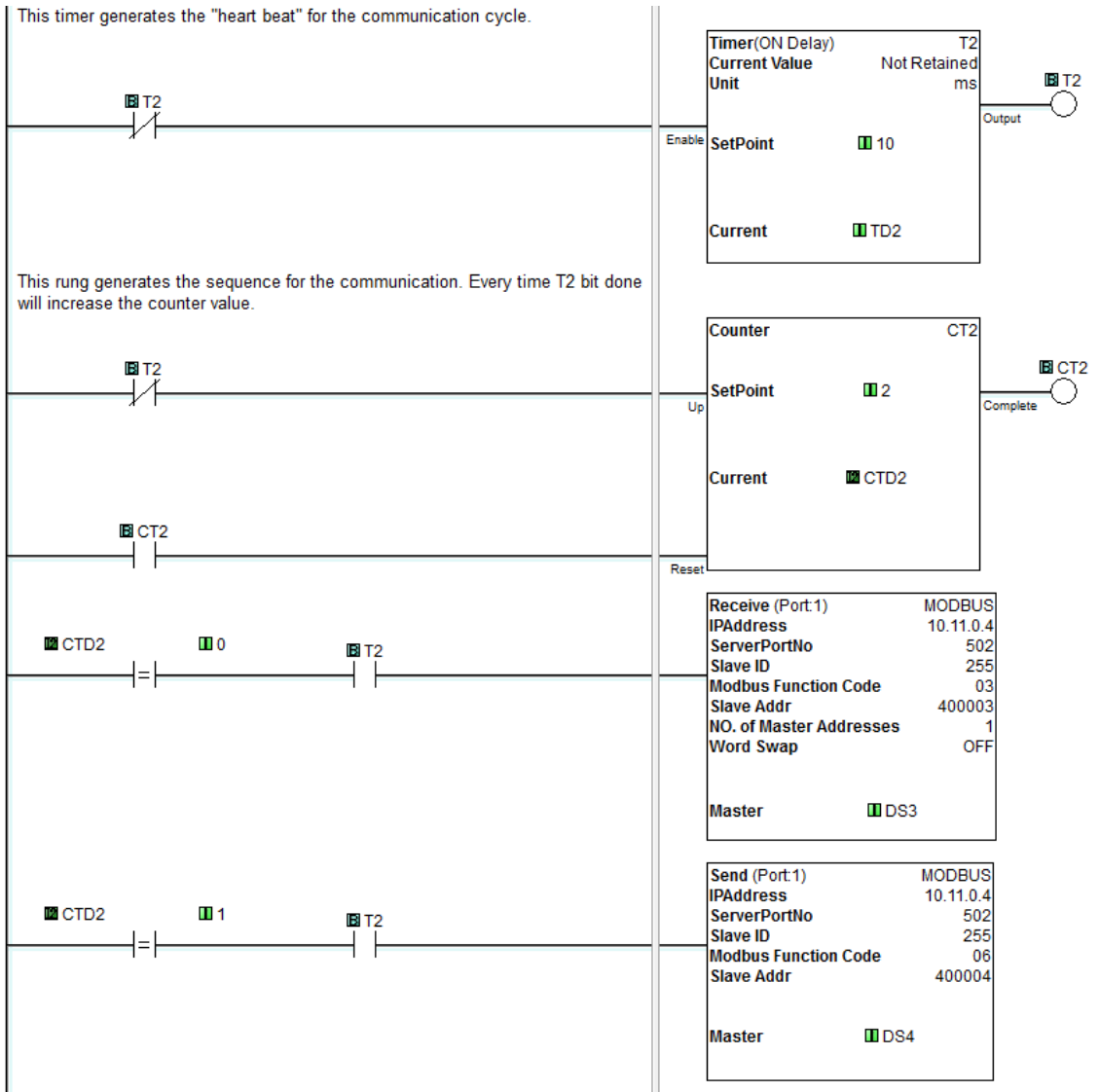

# P-4 P-4: ASCII Receive Programming

## Instruction

The Receive instruction allows the CLICK PLC to read ASCII message from an external device. To use this instruction, double click Receive in the Instruction List window as shown below.

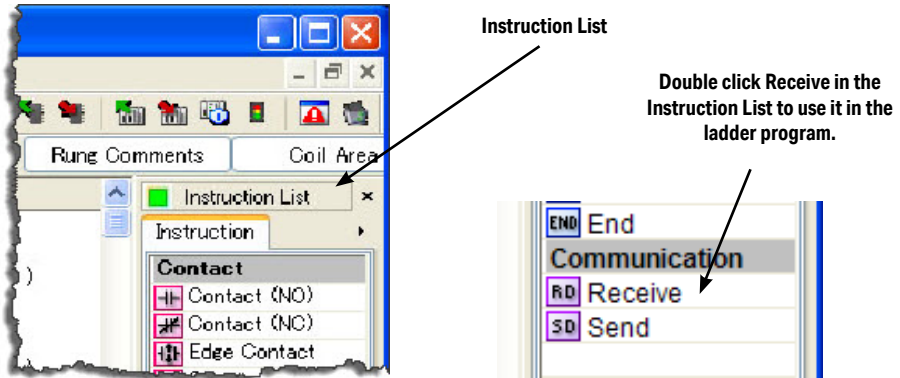

Select the Com Port that you are going to use and confirm the Protocol is ASCII.

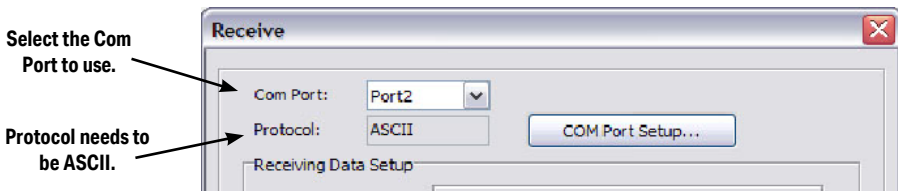

If the Protocol is not ASCII, click the Com Port Setup button to open the Com Port Setup Details window and change the Protocol to ASCII. If the Protocol selection is grayed out as shown below, it means the Com Port is used by another Receive and/or Send instruction in the ladder program. You cannot change the Protocol setup until you delete those instructions.



When you open the Receive instruction in the ASCII mode, the window should look like this. For the explanation of each setup parameter, please click the Help button on the bottom right

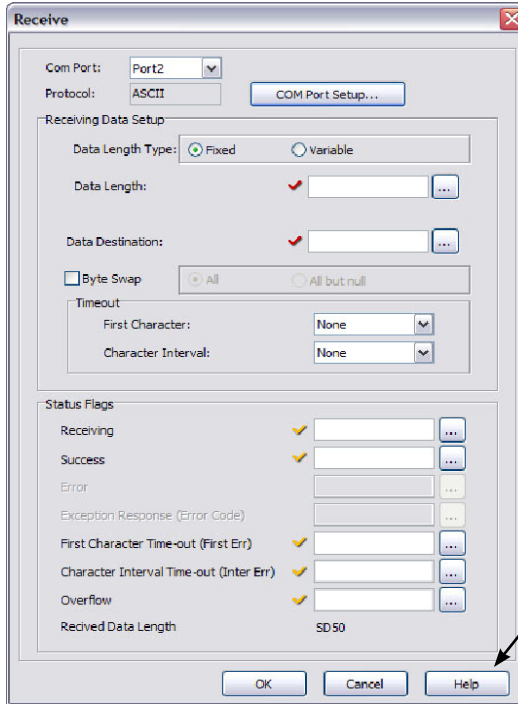

Click the Help button to get the detailed information of this setup window.

### Example 1: Read ASCII message from a barcode reader.

With the following example program, when C1 is ON, the Receive instruction is activated and Com Port 2 waits for an ASCII message from the barcode reader. When Com Port 2 receives an ASCII message and it includes the termination character (CR = Carriage Return in this example), C2 is turned on and the received ASCII message is copied to TXT1 address.

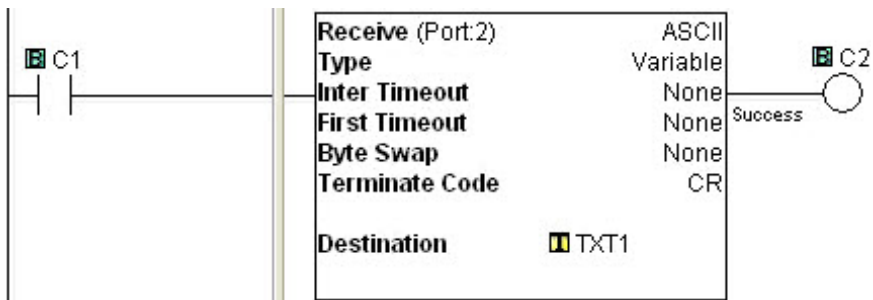

**Example 2: Retrieve numerical data from the received ASCII message.**

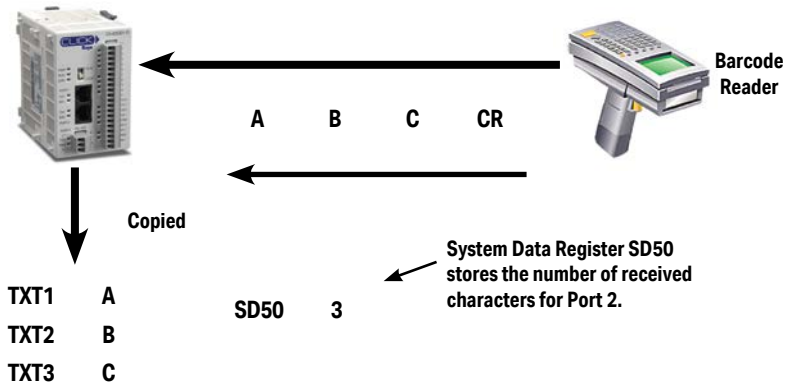

When numerical data is included in the received ASCII message, you may want to retrieve the numerical data and copy into a data register. The Copy instruction can be used for this purpose.

In this example, received ASCII message is stored in TXT1 to TXT6. This ASCII message includes numerical data '1.23' as ASCII characters from TXT3 to TXT6. The Copy instruction converts those ASCII characters into the equivalent numerical data and copies into data register DF1.

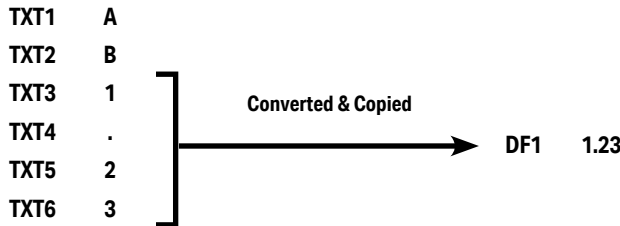
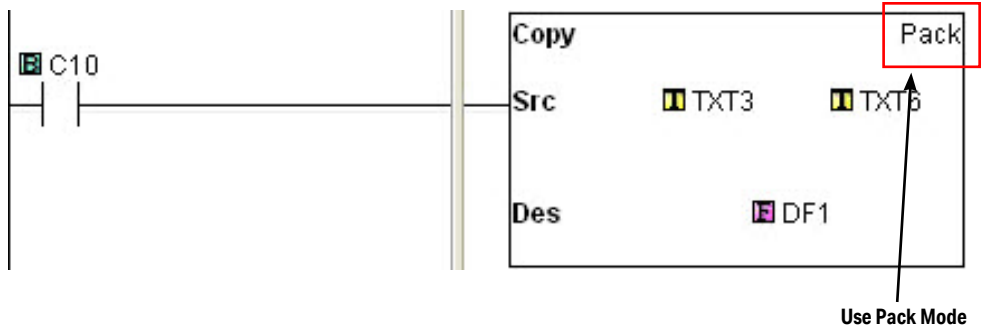

**P-5****P-5: ASCII Send Programming****Instruction**

The Send instruction allows the CLICK PLC to send ASCII messages to an external device. To use this instruction, double click Send in the Instruction List window as shown below.

Select the Com Port that you are going to use and confirm the Protocol is ASCII.

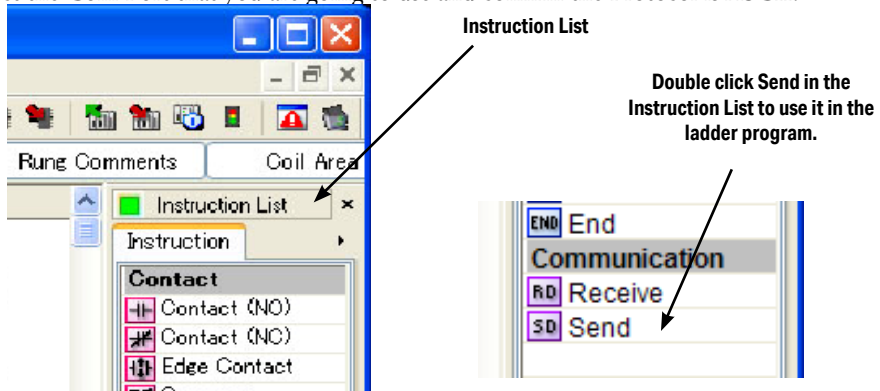

If the Protocol is not ASCII, click the Com Port Setup button to open the Com Port Setup Details window and change the Protocol to ASCII. If the Protocol selection is grayed out as



shown below, it means the Com Port is used by another Receive and/or Send instruction the ladder program. You cannot change the Protocol setup until you delete those instructions.



When you open the Send instruction in the ASCII mode, the window should look like this. For the explanation of each setup parameter, please click the Help button on the bottom right.

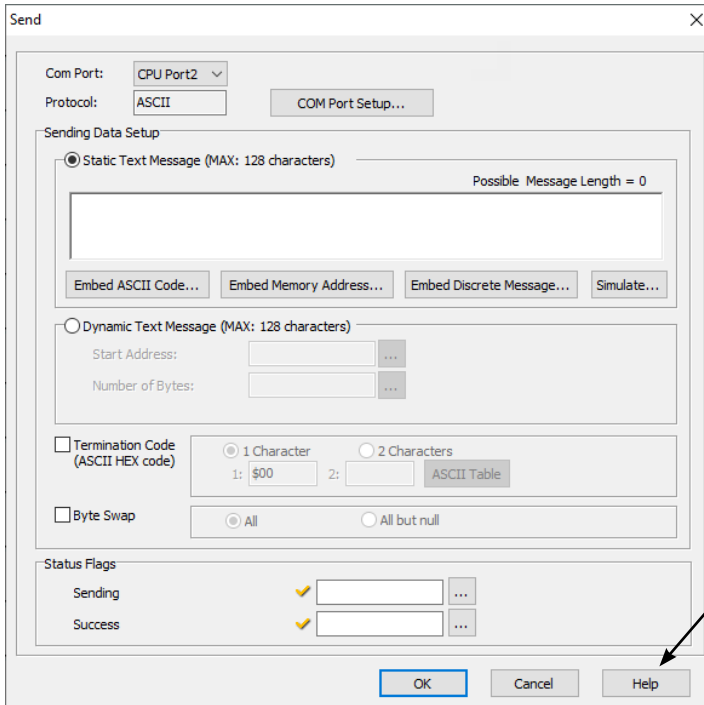

Click the Help button to get detailed information on this setup window.

### Example: Send ASCII message to a serial printer.

With the following example program, when status of C1 changes from OFF to ON, the Send instruction sends ASCII message 'ABC' and the termination character (CR = Carriage Return in this example). C2 is turned on when sending the ASCII message is completed.

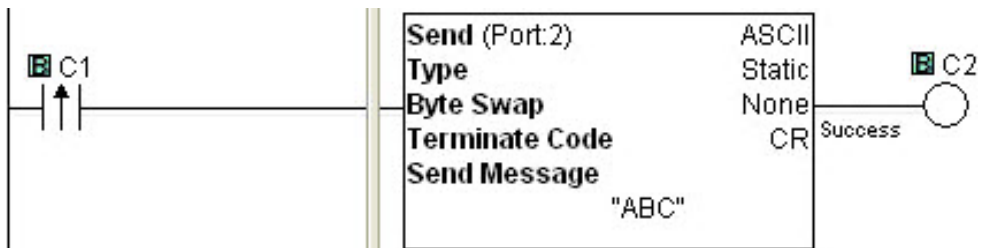

# MAINTENANCE

---

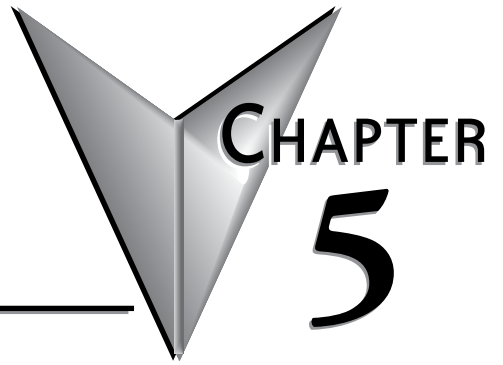

## In This Chapter...

PLC Maintenance .....	5-2
-----------------------	-----

# PLC Maintenance

Although the CLICK PLC requires very little maintenance, setting up a routine maintenance schedule will ensure the longevity of the PLC in your application. We suggest checking the following items as part of a quarterly or bi-annual preventative maintenance schedule.

### Check LED Indicators

Check the PWR and ERR LED indicators on the PLC and I/O modules. If the PWR LED indicator is off or flickering, or if the ERR indicator is on or flickering, refer to Chapter 6: *Troubleshooting* for more information.

### Project Backup

Saving a copy of the project file during routine maintenance ensures that you will have a fairly up-to-date backup copy of the PLC program. Although the CLICK PLC programming software can upload the complete project from the PLC anytime the PLC is operable, it is wise to maintain a project backup in case the PLC becomes inoperable and has to be replaced. The backup file of the project can then be downloaded into the new PLC.

### Check Operating Environment

Make sure that the CLICK PLC is operating within the proper temperature range (0–55°C; 32–131°F).

Make sure that the CLICK PLC is operating within the proper humidity range (30–95% RH, non-condensing).

Make sure that the CLICK PLC operating environment is free of corrosive gases.

### Check Operating Voltage

Check the input voltage that is powering the CLICK PLC to make sure that the voltage is within the appropriate range (20–28 VDC).

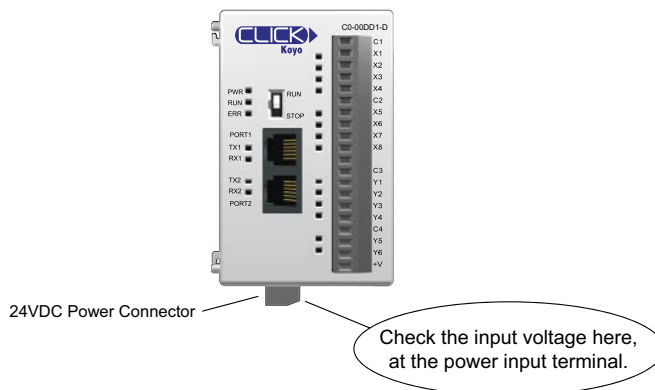

Check the input voltage for the I/O module terminal blocks. Refer to Chapter 2: *Specifications* for the voltage specifications of the various I/O modules.

### Check Physical Condition

Check the PLC and modules for distorted, warped, or discolored cases and burnt odors that could indicate overheated components.

Check to ensure that none of the PLC and module cooling vents are clogged or blocked by dust or debris. Make sure that there is sufficient unobstructed heat dissipation space around the PLC as shown in *Chapter 3: Installation and Wiring*.

Ensure that all of the CLICK PLC modules are connected together tightly. Also make sure that all communication cables, wiring, and terminal blocks are connected properly.



---

**WARNING: The CLICK PLC does not have hot swap capability. Do not disconnect or replace any I/O modules without first shutting off power to the PLC unit.**

---

### Check Project Functionality

During routine maintenance, check the functionality of your project (PLC program). Make sure the system or equipment that is being controlled is operating as intended.

### Check the PLC Program from CLICK PLC Programming Software

You can read the following PLC information from CLICK PLC programming software:

- System configuration.  
Check whether or not the PLC unit is recognizing the actual I/O configuration correctly.
- Error history.  
Check whether or not any errors occurred recently.
- Scan time.  
Check whether or not the scan time is normal, and if the minimum and maximum scan times are reasonable. Refer to Chapter 2: Specifications for information regarding scan times.

# TROUBLESHOOTING

---



## In This Chapter...

Troubleshooting Direction .....	6-2
PLC unit Troubleshooting .....	6-3
Power Supply Troubleshooting.....	6-5
I/O Module Troubleshooting .....	6-6
Troubleshooting Electrical Noise Problems.....	6-10
Error Codes.....	6-11

## Troubleshooting Direction

Use this section to figure out where to start when troubleshooting CLICK PLC problems.

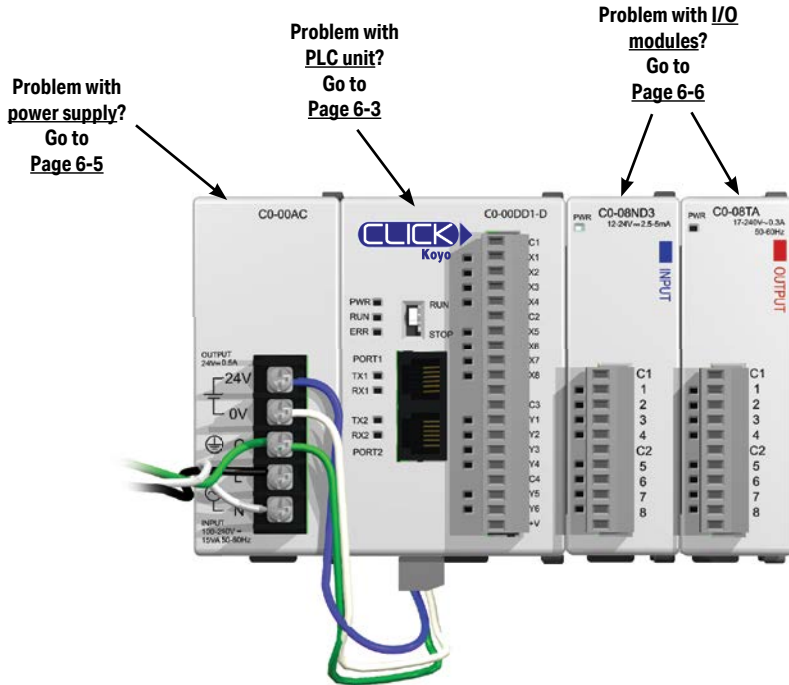

## PLC unit Troubleshooting

PLC unit issues are grouped according to their function. Use the illustration below to find the appropriate document page numbers for issues with different PLC unit functions.

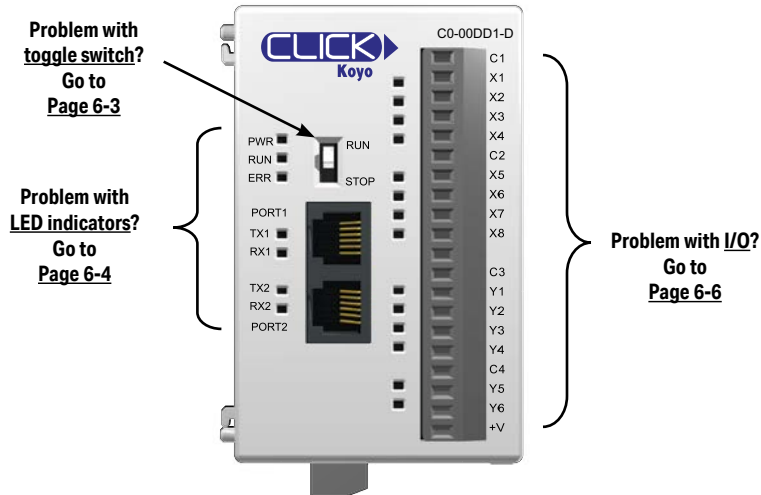

### Toggle Switch

#### Switch is in RUN position

When the toggle switch is in the RUN position, the PLC unit should normally be in Run mode (indicated by the RUN LED being ON), unless the PLC has been placed in Stop mode by a peripheral device through one of the communication ports. To put the PLC unit in Run mode, move the toggle switch to the STOP position and then switch it back again to the RUN position. If the RUN LED then remains off, check the PWR and ERR LED indicators per the chart shown below.

LED	Status*	Necessary action
PWR	OFF	There is insufficient power for the PLC unit. Check the power cable and input voltage.
ERR	ON	There is an error in the PLC unit. Connect the CLICK programming software to read the error information. See the "Error Codes" section at the end of this chapter for error message instructions.

\* If you see LED indications different from the ones shown in this table, refer to the "LED Indicators Troubleshooting" section for further explanations.

#### Switch is in STOP position

When the toggle switch is in STOP position, the PLC unit should be in Stop mode (indicated by the RUN LED being OFF). Cycle power to the PLC. If the PLC unit starts up in Run mode, with toggle switch in STOP position, it means the PLC unit does not recognize the toggle switch position correctly. Please replace the PLC unit.

## Chapter 6: Troubleshooting

### LED Indicators

The CLICK PLC performs many pre-defined diagnostic routines with every PLC scan, using onboard diagnostics that can detect various errors or failures in the PLC. LEDs on the face of the PLC will indicate for specific errors.

The 3 LEDs located next to the RUN/STOP switch power, (PWR, RUN and ERR) indicate the status of the PLC unit. The remainder of the LED indicators are discussed in later sections of this chapter:

- TX1/RX1/TX2/RX2/TX3/RX3 & LINK/ACT – Chapter 2

LED	Status	Meaning	Necessary action
PWR	On	The PLC is powered correctly.	No action is necessary.
	Blinking	The PLC input power is not sufficient.	Check the voltage on the terminal located on the bottom of the PLC. The input voltage should be 20-28 VDC. Also check the power input wiring & terminal connections. The power supply may need to be replaced.
	Off	There is no power to the PLC.	Check the voltage on the terminal located on the bottom of the PLC. The input voltage should be 20-28 VDC. Also check the power input wiring & terminal connections. The power supply may need to be replaced.
RUN	On	The PLC is in RUN mode.	If the toggle switch next to the LED indicators is in RUN position, no action is necessary. If the toggle switch is in STOP position, cycle power the PLC. If the PLC unit starts up in Run mode, it means that the PLC unit does not recognize the toggle switch position correctly, and the PLC unit must be replaced.
	Blinking	The PLC is initializing the C0-04RTD or C0-04THM.	When a C0-04RTD or C0-04THM is installed in the CLICK PLC system, the RUN LED blinks for up to 11 seconds to indicate that the PLC unit is initializing the analog input module after power-up. If the RUN LED keeps blinking after the initial 11 seconds, power cycle the CLICK PLC system. If the symptom remains, replace the PLC unit and/or the analog input module.
	Off	The PLC is in STOP mode.	If the toggle switch next to the LED indicators is in STOP position, no action is necessary. If the switch is in RUN position and you want to put the PLC unit in Run mode, toggle the switch to STOP position and then back to RUN position. If the RUN LED stays off, connect the CLICK programming software to read the error information. See the "Error Codes" section at the end of this chapter for error message instructions.
ERR	On	There is an error.	Connect the CLICK programming software to check the error. See the "Error Codes" section at the end of this chapter for error message instructions.
	Blinking	There is a warning.	Warnings do not prevent the PLC unit from running. However, you should check what warnings are active. Connect the CLICK programming software to read the warning information. See the "Error Codes" section at the end of this chapter for error message instructions.
	Off	There is no error.	No action is necessary.

- LED indicators for I/O – Chapter 2

#### Errors (ERR LED on)

Errors which may cause the system to function improperly, perhaps causing a safety problem. The PLC will automatically switch from RUN Mode to STOP Mode. (In STOP Mode all outputs are turned off.) If the PLC is already in STOP Mode when an error is detected, the PLC will not allow a transition to RUN Mode until the error has been corrected.

Examples of errors:

- I/O module error
- System configuration error
- Memory check error
- Project file error

#### Warnings (ERR LED blinking)

Warnings that require attention, but do not cause improper operation. They do not cause or prevent any PLC mode transitions. The application program can use system control bits to detect warnings, and even take the system to an orderly shutdown or switch the PLC to STOP Mode if desired. Examples of warnings:

- Lost SRAM data
- Battery low voltage

## Power Supply Troubleshooting

When the PWR LED is ON, the CLICK PLC is receiving enough power for operation. Verify the power input voltage at the bottom connector on the PLC unit; the input voltage should be 20–28 VDC.

### The input voltage measures less than 20VDC

Remove the bottom connector from the CLICK PLC unit and measure the voltage again. If the voltage at the connector then measures more than 20VDC, the power supply cannot provide enough current for the CLICK PLC. Replace the power supply with a higher output current power supply. Check the power budget to determine the current required from the power supply (see below).

If the voltage still measures less than 20VDC with the connector removed from the PLC, and the power supply voltage is not adjustable, then the power supply cannot be used for the CLICK PLC. Replace the power supply with another one.

### The input voltage measures greater than 28VDC

If the output current of the power supply is adjustable, decrease the output voltage. If the output voltage cannot be lowered to less than 28VDC, replace the power supply with another one.

### How to check the power budget

You can use the programming software to check the power budget of the CLICK PLC:

- Connect the PLC to a computer running the CLICK programming software.
- From the software menus, connect the software to the PLC by selecting PLC and Connect...
- From the software menus, select Setup and System Configuration...
- The System Configuration Setup window opens, and displays the Power Budget in milliamps (mA) required by the PLC system. The PLC power supply must be capable of providing more current than the Power Budget amount.

# I/O Module Troubleshooting

First, check the status of the PWR LED indicators on the I/O modules. If the PWR LED on the PLC unit is on, but there are I/O modules which have PWR LEDs that are off, check the connections between the modules. If the I/O module PWR LEDs remain off, replace those modules.

Troubleshooting input modules is slightly different from troubleshooting output modules. Please refer to the proper subsection:

- Input module troubleshooting
- Output module troubleshooting

## Input Module Troubleshooting

The input modules (including the PLC built-in inputs) can have the following symptoms:

Symptom	Necessary Action
Input signal is on, but the LED indicator on the module is off.	Check the external power input voltage on the terminal block.
	Check whether the terminal block is attached correctly.
	If the input voltage is correct but the LED indicator is still off, replace the input module.
The LED indicator is on, but the PLC does not work as expected.	Check whether the PLC unit RUN LED is ON. If not, put the PLC in RUN mode.
	Check the I/O configuration with the programming software. (See "How to Check the I/O Configuration" on the next page.)
	Connect the programming software and check the X bit related to the input point that is on. (See "How to Check the I/O Status" later in this section for instructions.) If the X bit is off, replace the input module.

## Output Module Troubleshooting

The output modules (including the PLC built-in outputs) can have the following symptoms:

Symptom	Necessary Action
The module LED indicator is ON, but there is no output.	Check the external power input voltage on the terminal block.
	Check whether the terminal block is attached correctly.
	If it is a DC sinking, relay, or AC output, check the voltage between the output and the common. If the output is working correctly, the voltage should be close to zero.
	If it is a sourcing output, check the voltage between the output and the 24 VDC input. If the output is working correctly, the voltage should be close to zero.
The module LED indicator is ON, but the output voltage is not correct, replace the output module.	If the LED indicator is ON, but the output voltage is not correct, replace the output module.
	Check whether the PLC unit RUN LED is ON. If not, put the PLC in RUN mode.
	Check the I/O configuration with the programming software. (See "How to Check the I/O Configuration" below.)
	Connect the programming software and check whether the Y bit related to the output point is ON. If the Y bit is not actually ON, use the override feature to manually turn the Y bit ON. (See "How to Check the I/O Status" on the next page.)
If the Y bit is ON, but the output is OFF, replace the output module.	If the Y bit is ON, but the output is OFF, replace the output module.
The module LED indicator is OFF, but the output is sending an ON signal to the field device.	Leakage current can be a problem when connecting field devices to I/O modules. False input signals can be generated when the leakage current of the output point is great enough to turn on the connected input device.
	To correct this issue, install a resistor in parallel with the input or output of the circuit. The value of this resistor will depend on the amount of leakage current and the voltage applied, but usually a 10k to 20k ohm resistor will work. Ensure that the wattage rating of the resistor is correct for your application.

## How to Check the I/O Configuration

You can use the CLICK programming software to check the I/O configuration that the PLC is recognizing:

- Connect the PLC to a computer running the CLICK programming software.
- From the software menus, connect the software to the PLC by selecting PLC and Connect...
- From the software menus, select Setup and System Configuration...
- The System Configuration Setup window opens, and displays all of the CLICK module types the PLC recognizes that are connected in the PLC system.

## Chapter 6: Troubleshooting

### How to Check the I/O Status

You can use CLICK programming software Data View window to check the I/O status in the PLC unit.



**WARNING: Only authorized personnel fully familiar with all aspects of the application should make changes to the program. Make sure that you thoroughly consider the impact of any changes to minimize the risk of personal injury or damage to equipment. Specifically, forcing inputs and outputs to their ON state will cause externally connected equipment to operate.**

Open or create a data view window by selecting Monitor and Data View from either the menu bar, the Navigation window, or the Data View icon.

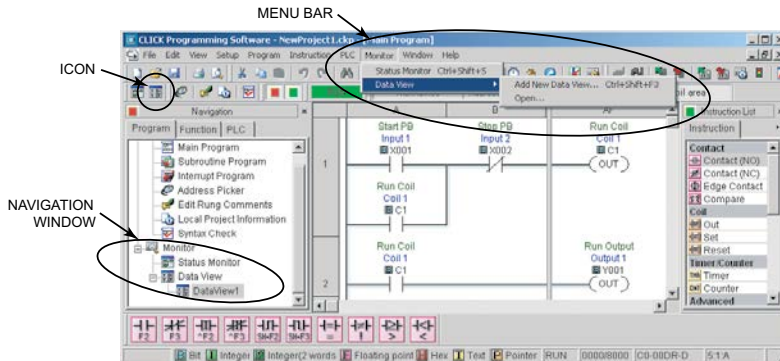

To add new memory addresses to a Data View window:

- Click on an empty Address field to bring up a small browser button.
- Click the browser button to open the Address Picker window. 
- From the Address Picker window, click the Pickup Mode button, select the desired I/O or memory location, and then click OK to add that address into the data view.

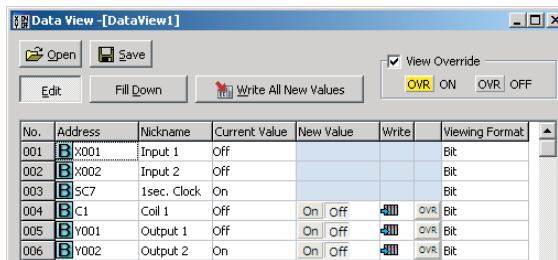

No.	Address	Nickname	Current Value	New Value	Write	Viewing Format
001	X001	Input 1	Off			Bit
002	X002	Input 2	Off			Bit
003	SC7	1sec. Clock	On			Bit
004	C1	Coil 1	Off	On Off		OVR Bit
005	Y001	Output 1	Off	On Off		OVR Bit
006	Y002	Output 2	On	On Off		OVR Bit

To troubleshoot I/O from the Data View window:

- Connect to PLC unit
- Force outputs on/off, then check actual outputs to see whether they are actually on or off.
- Edit, Write All New Values, or double click individual output Write icon.
- Externally turn inputs on or off, then check their status in data view. Inputs cannot be forced from Data View.

### Replacement of I/O modules

---



**WARNING: The CLICK PLC does not have hot swap capability. Do not disconnect or replace any I/O modules without first shutting off power to the PLC unit.**

---

Before replacing an I/O module, please consider the cause of the module problem. If you suspect that another device may have caused the failure in the module, that device may also cause the same failure in the replacement module. As a precaution, you may want to check power supplies or other devices connected to the failed module before replacing it.

# Troubleshooting Electrical Noise Problems

## Electrical Noise Problems

Noise is one of the most difficult problems to diagnose. Electrical noise can enter a system in many different ways and can fall into one of two categories, conducted noise or radiated noise. It may be difficult to determine how the noise is entering the system, but the corrective actions are similar for both types of noise problems.

- Conducted noise is electrical interference introduced into the system by way of an attached wire, panel connection, etc. The interference may enter through an I/O circuit, a power supply connection, the communication ground connection, or the chassis ground connection.
- Radiated noise is electrical interference introduced into the system without a direct electrical connection, much in the same manner as radio waves.

## Reducing Electrical Noise

Although electrical noise cannot be completely eliminated, it can be reduced to a level that will not adversely affect the system.

- Most noise problems result from improper grounding of the system. A good earth ground can be the single most effective way to correct noise problems. If a ground is not available, install a ground rod as close to the system as possible. Ensure that all ground wires are single point grounds, and are not daisy chained from one device to another. Ground other metal enclosures near the system. A loose wire can act as a large antenna, introducing noise into the system; so, tighten all connections in your system. Loose ground wires are more susceptible to noise than the other wires in your system. Review *Chapter 3: Installation and Wiring*, if you have questions regarding how to ground your system.
- Electrical noise can enter the system through the power source for the PLC and I/O circuits. Installing an isolation transformer for all AC sources can correct this problem. DC sources should be well-grounded, good quality power supplies.
- Separate input wiring from output wiring. Never run low-voltage I/O wiring close to high voltage wiring.

## Error Codes

When there is an Error or Warning, the error code is stored in the System Data register SD1.

When an Error occurs during the operation, the CLICK PLC system goes to the STOP mode immediately and the ERR LED on the PLC unit turns on. On the other hand, when a Warning occurs during the operation, the CLICK PLC system stays in RUN mode and the ERR LED on the PLC unit starts blinking.

In the error code tables that follow, the Category column indicates whether the error code is an Error or a Warning. If any of the Warnings listed is critical for your control system, add an additional ladder program to put the CLICK PLC system in STOP mode when that specific Warning occurs. Here is an example.

### Example

X102 turns on when the analog I/O module in the I/O1 position is missing external 24VDC input.

By turning the System Control bit SC50 on, the CLICK PLC system goes in the STOP mode.



PLC Error Codes					
Error Code	Status Flag*	Error Name	Category	Causes	Solutions
101	SC20	I/O Module Error	Error	There are more than 8 I/O modules.	A CLICK PLC system can support up to 8 I/O modules. Remove any excessive I/O modules.
				At least one I/O module was added to the CLICK PLC during operation.	Power off the CLICK PLC and check the connection of the I/O modules. Then power on the CLICK PLC again. If the problem remains, connect the CLICK software to the PLC and check the System Configuration. If there is any I/O module that is not shown in the System Configuration, replace it.
				An I/O module has failed.	Connect the CLICK software to the CLICK PLC and check the system configuration. If there is any I/O module that is used in the PLC system but not shown in the System Configuration window, replace the I/O module.
102	SC21	System Config Error	Error	The current system configuration does not match the configuration saved in the project file.	Connect the CLICK software to the CLICK PLC and open the System Configuration window. Modify the current configuration of the CLICK PLC to match the configuration in the project file, or uncheck the 'Start-up I/O Config Check' option if you want to use the current configuration.

\* The Status Flags are turned ON when the related errors occur.

Error code table continued on next page.

## Error Codes (continued)

PLC Error Codes					
Error Code	Status Flag*	Error Name	Category	Causes	Solutions
103	SC22	I/O Config Error	Error	At least one I/O module was removed from the CLICK PLC during operation.	Power off the CLICK PLC and check the connection of the I/O modules. Then power on the CLICK PLC again. If the problem remains, connect the CLICK software to the PLC and check the System Configuration. If there is any I/O module that is not shown in the System Configuration, replace it.
				The PLC unit can not access one or more I/O modules.	Connect the CLICK software to the CLICK PLC and open the System Configuration window. If there is any I/O module that is used in the PLC system but not shown in the System Configuration window, replace the I/O module.
104	SC23	Memory Check Error	Error	There is a memory check error.	Power cycle the CLICK PLC. If the same error occurs again, download the project again and/or try the 'Reset to Factory Default' command. If the same error still occurs, replace the PLC unit.
105	SC24	Project File Error	Error	There is no project file in the CLICK PLC.	Download a project file into the CLICK PLC.
				The project file stored in the CLICK PLC is corrupted.	Download the project file into the CLICK PLC again.
106	SC25	Firmware Version Error	Error	The project file was written on a newer version of CLICK software. The firmware in the CLICK PLC is too old to execute the project.	Connect the CLICK software to the CLICK PLC and update the firmware of the PLC unit.
107	SC26	Watchdog Timer Error	Error	The PLC scan time exceeded the watchdog timer setup.	Connect the CLICK software to the PLC and check the maximum PLC scan time and the watchdog timer setup.
108	SC26	Interrupt Watchdog Timer Error	Error	The PLC scan time exceeded the watchdog timer setup.	The watchdog timer was exceeded while executing an Interrupt Program. Reduce the occurrences of Interrupts, or reduce the executing time of the Interrupt Programs to prevent this error.
201	SC27	Lost SRAM Data	Warning	The data in the SRAM was lost while the CLICK PLC was powered off.	The Basic PLC units do not have a battery back-up, but they have a capacitor that will hold memory for a few days. The data in the SRAM is lost if the CLICK PLC is powered off for long enough for the capacitor to discharge. In this case, the CLICK PLC initializes the data in the SRAM automatically. This also applies to Standard and Analog PLC units if a battery is not installed.
202	SC28	Battery Low Voltage	Warning	Battery voltage is too low to retain data in the SRAM.	Replace the battery (ADC part #: D2-BAT-1). Also, set the new battery installation date and the anticipated replacement date in the CLICK programming software if the Battery Replacement Notification option is selected. (Pull-down menu: Setup > Battery Backup Setup)
203	SC29	Battery Replacement	Warning	The anticipated battery replacement date has passed.	Replace the battery (ADC part #: D2-BAT-1). Also, set the new battery installation date and the anticipated replacement date in the CLICK programming software. (Pull-down menu: Setup > Battery Backup Setup)

\*The SC bits are turned ON when the related errors occur.

Error code table continued on next page.

## Error Codes (continued)

PLC Error Codes					
Error Code	Status Flag*	Error Name	Category	Causes	Solutions
301	X101	I01 Module Error	Error	The analog I/O module in I/O1 position is not functioning.	Power cycle the CLICK PLC. If the same error occurs again, replace the analog I/O module.
302	X201	I02 Module Error	Error	The analog I/O module in I/O2 position is not functioning.	Power cycle the CLICK PLC. If the same error occurs again, replace the analog I/O module.
303	X301	I03 Module Error	Error	The analog I/O module in I/O3 position is not functioning.	Power cycle the CLICK PLC. If the same error occurs again, replace the analog I/O module.
304	X401	I04 Module Error	Error	The analog I/O module in I/O4 position is not functioning.	Power cycle the CLICK PLC. If the same error occurs again, replace the analog I/O module.
305	X501	I05 Module Error	Error	The analog I/O module in I/O5 position is not functioning.	Power cycle the CLICK PLC. If the same error occurs again, replace the analog I/O module.
306	X601	I06 Module Error	Error	The analog I/O module in I/O6 position is not functioning.	Power cycle the CLICK PLC. If the same error occurs again, replace the analog I/O module.
307	X701	I07 Module Error	Error	The analog I/O module in I/O7 position is not functioning.	Power cycle the CLICK PLC. If the same error occurs again, replace the analog I/O module.
308	X801	I08 Module Error	Error	The analog I/O module in I/O8 position is not functioning.	Power cycle the CLICK PLC. If the same error occurs again, replace the analog I/O module.
310	X102	I01 Missing 24V	Warning	The analog I/O module in I/O1 position is missing external 24VDC input.	Apply 24VDC to the analog I/O module.
311	X103	I01 CH1 Burnout	Warning	CH1 on the analog I/O module in I/O1 position senses burnout or open circuit.	Check the wiring for CH1. Replace the sensor if it is broken.
312	X106	I01 CH2 Burnout	Warning	CH2 on the analog I/O module in I/O1 position senses burnout or open circuit.	Check the wiring for CH2. Replace the sensor if it is broken.
313	X109	I01 CH3 Burnout	Warning	CH3 on the analog I/O module in I/O1 position senses burnout or open circuit.	Check the wiring for CH3. Replace the sensor if it is broken.
314	X112	I01 CH4 Burnout	Warning	CH4 on the analog I/O module in I/O1 position senses burnout or open circuit.	Check the wiring for CH4. Replace the sensor if it is broken.
320	X202	I02 Missing 24V	Warning	The analog I/O module in I/O2 position is missing external 24VDC input.	Apply 24VDC to the analog I/O module.
321	X203	I02 CH1 Burnout	Warning	CH1 on the analog I/O module in I/O2 position senses burnout or open circuit.	Check the wiring for CH1. Replace the sensor if it is broken.
322	X206	I02 CH2 Burnout	Warning	CH2 on the analog I/O module in I/O2 position senses burnout or open circuit.	Check the wiring for CH2. Replace the sensor if it is broken.

\* The Status Flags are turned ON when the related errors occur.

Error code table continued on next page.

## Error Codes (continued)

PLC Error Codes					
Error Code	Status Flag*	Error Name	Category	Causes	Solutions
323	X209	I02 CH3 Burnout	Warning	CH3 on the analog I/O module in I/02 position senses burnout or open circuit.	Check the wiring for CH3. Replace the sensor if it is broken.
324	X212	I02 CH4 Burnout	Warning	CH4 on the analog I/O module in I/02 position senses burnout or open circuit.	Check the wiring for CH4. Replace the sensor if it is broken.
330	X302	I03 Missing 24V	Warning	The analog I/O module in I/03 position is missing external 24VDC input.	Apply 24VDC to the analog I/O module.
331	X303	I03 CH1 Burnout	Warning	CH1 on the analog I/O module in I/03 position senses burnout or open circuit.	Check the wiring for CH1. Replace the sensor if it is broken.
332	X306	I03 CH2 Burnout	Warning	CH2 on the analog I/O module in I/03 position senses burnout or open circuit.	Check the wiring for CH2. Replace the sensor if it is broken.
333	X309	I03 CH3 Burnout	Warning	CH3 on the analog I/O module in I/03 position senses burnout or open circuit.	Check the wiring for CH3. Replace the sensor if it is broken.
334	X312	I03 CH4 Burnout	Warning	CH4 on the analog I/O module in I/03 position senses burnout or open circuit.	Check the wiring for CH4. Replace the sensor if it is broken.
340	X402	I04 Missing 24V	Warning	The analog I/O module in I/04 position is missing external 24VDC input.	Apply 24VDC to the analog I/O module.
341	X403	I04 CH1 Burnout	Warning	CH1 on the analog I/O module in I/04 position senses burnout or open circuit.	Check the wiring for CH1. Replace the sensor if it is broken.
342	X406	I04 CH2 Burnout	Warning	CH2 on the analog I/O module in I/04 position senses burnout or open circuit.	Check the wiring for CH2. Replace the sensor if it is broken.
343	X409	I04 CH3 Burnout	Warning	CH3 on the analog I/O module in I/04 position senses burnout or open circuit.	Check the wiring for CH3. Replace the sensor if it is broken.
344	X412	I04 CH4 Burnout	Warning	CH4 on the analog I/O module in I/04 position senses burnout or open circuit.	Check the wiring for CH4. Replace the sensor if it is broken.
350	X502	I05 Missing 24V	Warning	The analog I/O module in I/05 position is missing external 24VDC input.	Apply 24VDC to the analog I/O module.
351	X503	I05 CH1 Burnout	Warning	CH1 on the analog I/O module in I/05 position senses burnout or open circuit.	Check the wiring for CH1. Replace the sensor if it is broken.
352	X506	I05 CH2 Burnout	Warning	CH2 on the analog I/O module in I/05 position senses burnout or open circuit.	Check the wiring for CH2. Replace the sensor if it is broken.
353	X509	I05 CH3 Burnout	Warning	CH3 on the analog I/O module in I/05 position senses burnout or open circuit.	Check the wiring for CH3. Replace the sensor if it is broken.

\* The Status Flags are turned ON when the related errors occur.

Error code table continued on next page.

## Error Codes (continued)

PLC Error Codes					
Error Code	Status Flag*	Error Name	Category	Causes	Solutions
354	X512	IO5 CH4 Burnout	Warning	CH4 on the analog I/O module in I/O5 position senses burnout or open circuit.	Check the wiring for CH4. Replace the sensor if it is broken.
360	X602	IO6 Missing 24V	Warning	The analog I/O module in I/O6 position is missing external 24VDC input.	Apply 24VDC to the analog I/O module.
361	X603	IO6 CH1 Burnout	Warning	CH1 on the analog I/O module in I/O6 position senses burnout or open circuit.	Check the wiring for CH1. Replace the sensor if it is broken.
362	X606	IO6 CH2 Burnout	Warning	CH2 on the analog I/O module in I/O6 position senses burnout or open circuit.	Check the wiring for CH2. Replace the sensor if it is broken.
363	X609	IO6 CH3 Burnout	Warning	CH3 on the analog I/O module in I/O6 position senses burnout or open circuit.	Check the wiring for CH3. Replace the sensor if it is broken.
364	X612	IO6 CH4 Burnout	Warning	CH4 on the analog I/O module in I/O6 position senses burnout or open circuit.	Check the wiring for CH4. Replace the sensor if it is broken.
370	X702	IO7 Missing 24V	Warning	The analog I/O module in I/O7 position is missing external 24VDC input.	Apply 24VDC to the analog I/O module.
371	X703	IO7 CH1 Burnout	Warning	CH1 on the analog I/O module in I/O7 position senses burnout or open circuit.	Check the wiring for CH1. Replace the sensor if it is broken.
372	X706	IO7 CH2 Burnout	Warning	CH2 on the analog I/O module in I/O7 position senses burnout or open circuit.	Check the wiring for CH2. Replace the sensor if it is broken.
373	X709	IO7 CH3 Burnout	Warning	CH3 on the analog I/O module in I/O7 position senses burnout or open circuit.	Check the wiring for CH3. Replace the sensor if it is broken.
374	X712	IO7 CH4 Burnout	Warning	CH4 on the analog I/O module in I/O7 position senses burnout or open circuit.	Check the wiring for CH4. Replace the sensor if it is broken.
380	X802	IO8 Missing 24V	Warning	The analog I/O module in I/O8 position is missing external 24VDC input.	Apply 24VDC to the analog I/O module.
381	X803	IO8 CH1 Burnout	Warning	CH1 on the analog I/O module in I/O8 position senses burnout or open circuit.	Check the wiring for CH1. Replace the sensor if it is broken.
382	X806	IO8 CH2 Burnout	Warning	CH2 on the analog I/O module in I/O8 position senses burnout or open circuit.	Check the wiring for CH2. Replace the sensor if it is broken.
383	X809	IO8 CH3 Burnout	Warning	CH3 on the analog I/O module in I/O8 position senses burnout or open circuit.	Check the wiring for CH3. Replace the sensor if it is broken.
384	X812	IO8 CH4 Burnout	Warning	CH4 on the analog I/O module in I/O8 position senses burnout or open circuit.	Check the wiring for CH4. Replace the sensor if it is broken.

\* The Status Flags are turned ON when the related errors occur.

# **SECURITY CONSIDERATIONS FOR CONTROL SYSTEMS NETWORKS**

---



**In This Appendix...**

Security Considerations for Control Systems Networks..... A-2

## Security Considerations for Control Systems Networks

Manufacturers are realizing that to stay competitive, their Automation and Control Systems need to be more integrated within their plant. The systems often need to be integrated with upstream Enterprise Data Systems, and even further integrated to allow information to be accessible across multiple plants, or even through the Internet. This convergence of the IT world with the Automation World creates challenges in maintaining secure systems and protecting your investments in processes, personnel, data and intellectual property.

While Automation Networks and Systems have built-in password protection schemes, this is only one very small step in securing your systems. Automation Control System Networks need to incorporate data protection and security measures that are at least as robust as a typical business computer system. We recommend that users of PLCs, HMI products and SCADA systems perform your own network security analysis to determine the proper level of security required for your application. However, the Department of Homeland Security's National Cybersecurity and Communications Integration Center (NCCIC) and Industrial Control Systems Cyber Emergency Response Team (ICS-CERT) has provided direction related to network security and safety under an approach described as "Defense in Depth", which is published at [https://www.us-cert.gov/sites/default/files/recommended\\_practices/NCCIC\\_ICSCERT\\_Defense\\_in\\_Depth\\_2016\\_S508C.pdf](https://www.us-cert.gov/sites/default/files/recommended_practices/NCCIC_ICSCERT_Defense_in_Depth_2016_S508C.pdf).

This comprehensive security strategy involves physical protection methods, as well as process and policy methods. This approach creates multiple layers and levels of security for industrial automation systems. Such safeguards include the location of control system networks behind firewalls, their isolation from business networks, the use of intrusion detection systems, and the use of secure methods for remote access such as Virtual Private Networks (VPNs). Further, users should minimize network exposure for all control system devices and such control systems, and these systems should not directly face the internet. Following these procedures should significantly reduce your risks both from external sources as well as internal sources, and provide a more secure system.

It is the user's responsibility to protect such systems, just as you would protect your computer and business systems. AutomationDirect recommends using one or more of these resources in putting together a secure system:

- ICS-CERT's Control Systems recommended practices at the following web address: <https://ics-cert.us-cert.gov/Recommended-Practices>
- Special Publication 800-82 of the National Institute of Standards and Technology – Guide to Industrial Control Systems (ICS) Security: <https://csrc.nist.gov/publications/detail/sp/800-82/rev-2/final>
- ISA99, Industrial Automation and Control Systems Security: <https://www.isa.org/standards-and-publications/isa-standards/isa-standards-committees/isa99> (please note this is a summary and these standards have to be purchased from ISA)

The above set of resources provides a comprehensive approach to securing a control system network and reducing risk and exposure from security breaches. Given the nature of any system that accesses the internet, it is incumbent upon each user to assess the needs and requirements of their application, and take steps to mitigate the particular security risks inherent in their control system.