



Manual Number: P2CDS-USER-M

~ WARNING ~

Thank you for purchasing automation equipment from Automationdirect.com®, doing business as, AutomationDirect. We want your new automation equipment to operate safely. Anyone who installs or uses this equipment should read this publication (and any other relevant publications) before installing or operating the equipment.

To minimize the risk of potential safety problems, you should follow all applicable local and national codes that regulate the installation and operation of your equipment. These codes vary from area to area and usually change with time. It is your responsibility to determine which codes should be followed, and to verify that the equipment, installation, and operation is in compliance with the latest revision of these codes.

At a minimum, you should follow all applicable sections of the National Fire Code, National Electrical Code, and the codes of the National Electrical Manufacturer's Association (NEMA). There may be local regulatory or government offices that can also help determine which codes and standards are necessary for safe installation and operation.

Equipment damage or serious injury to personnel can result from the failure to follow all applicable codes and standards. We do not guarantee the products described in this publication are suitable for your particular application, nor do we assume any responsibility for your product design, installation, or operation.

Our products are not fault-tolerant and are not designed, manufactured or intended for use or resale as on-line control equipment in hazardous environments requiring fail-safe performance, such as in the operation of nuclear facilities, aircraft navigation or communication systems, air traffic control, direct life support machines, or weapons systems, in which the failure of the product could lead directly to death, personal injury, or severe physical or environmental damage ("High Risk Activities"). AutomationDirect specifically disclaims any expressed or implied warranty of fitness for High Risk Activities.

For additional warranty and safety information, see the Terms and Conditions section of our catalog. If you have any questions concerning the installation or operation of this equipment, or if you need additional information, please call us at 770-844-4200.

This publication is based on information that was available at the time it was printed. At AutomationDirect we constantly strive to improve our products and services, so we reserve the right to make changes to the products and/or publications at any time without notice and without any obligation. This publication may also discuss features that may not be available in certain revisions of the product.

Trademarks

This publication may contain references to products produced and/or offered by other companies. The product and company names may be trademarked and are the sole property of their respective owners. AutomationDirect disclaims any proprietary interest in the marks and names of others.

**Copyright© 2025, Automationdirect.com® Incorporated
All Rights Reserved**

No part of this manual shall be copied, reproduced, or transmitted in any way without the prior, written consent of Automationdirect.com® Incorporated. AutomationDirect retains the exclusive rights to all information included in this document.

⚡ ADVERTENCIA ⚡

Gracias por comprar equipo de automatización de Automationdirect.com®. Deseamos que su nuevo equipo de automatización opere de manera segura. Cualquier persona que instale o use este equipo debe leer esta publicación (y cualquier otra publicación pertinente) antes de instalar u operar el equipo.

Para reducir al mínimo el riesgo debido a problemas de seguridad, debe seguir todos los códigos de seguridad locales o nacionales aplicables que regulan la instalación y operación de su equipo. Estos códigos varían de área en área y usualmente cambian con el tiempo. Es su responsabilidad determinar cuales códigos deben ser seguidos y verificar que el equipo, instalación y operación estén en cumplimiento con la revisión más reciente de estos códigos.

Como mínimo, debe seguir las secciones aplicables del Código Nacional de Incendio, Código Nacional Eléctrico, y los códigos de (NEMA) la Asociación Nacional de Fabricantes Eléctricos de USA. Puede haber oficinas de normas locales o del gobierno que pueden ayudar a determinar cuales códigos y normas son necesarios para una instalación y operación segura.

Si no se siguen todos los códigos y normas aplicables, puede resultar en daños al equipo o lesiones serias a personas. No garantizamos los productos descritos en esta publicación para ser adecuados para su aplicación en particular, ni asumimos ninguna responsabilidad por el diseño de su producto, la instalación u operación.

Nuestros productos no son tolerantes a fallas y no han sido diseñados, fabricados o intencionados para uso o reventa como equipo de control en línea en ambientes peligrosos que requieren una ejecución sin fallas, tales como operación en instalaciones nucleares, sistemas de navegación aérea, o de comunicación, control de tráfico aéreo, máquinas de soporte de vida o sistemas de armamentos en las cuales la falla del producto puede resultar directamente en muerte, heridas personales, o daños físicos o ambientales severos ("Actividades de Alto Riesgo"). Automationdirect.com específicamente rechaza cualquier garantía ya sea expresada o implicada para actividades de alto riesgo.

Para información adicional acerca de garantía e información de seguridad, vea la sección de Términos y Condiciones de nuestro catálogo. Si tiene alguna pregunta sobre instalación u operación de este equipo, o si necesita información adicional, por favor llámenos al número 770-844-4200 en Estados Unidos.

Esta publicación está basada en la información disponible al momento de impresión. En Automationdirect.com nos esforzamos constantemente para mejorar nuestros productos y servicios, así que nos reservamos el derecho de hacer cambios al producto y/o a las publicaciones en cualquier momento sin notificación y sin ninguna obligación. Esta publicación también puede discutir características que no estén disponibles en ciertas revisiones del producto.

Marcas Registradas

Esta publicación puede contener referencias a productos producidos y/u ofrecidos por otras compañías. Los nombres de las compañías y productos pueden tener marcas registradas y son propiedad única de sus respectivos dueños. Automationdirect.com, renuncia cualquier interés propietario en las marcas y nombres de otros.

**Propiedad Literaria© 2025, Automationdirect.com® Incorporated
Todos los derechos reservados**

No se permite copiar, reproducir, o transmitir de ninguna forma ninguna parte de este manual sin previo consentimiento por escrito de Automationdirect.com® Incorporated. Automationdirect.com retiene los derechos exclusivos a toda la información incluida en este documento. Los usuarios de este equipo pueden copiar este documento solamente para instalar, configurar y mantener el equipo correspondiente. También las instituciones de enseñanza pueden usar este manual para propósitos educativos.

⚡ AVERTISSEMENT ⚡

Nous vous remercions d'avoir acheté l'équipement d'automatisation de AutomationDirect.com®, en faisant des affaires comme, AutomationDirect. Nous tenons à ce que votre nouvel équipement d'automatisation fonctionne en toute sécurité. Toute personne qui installe ou utilise cet équipement doit lire la présente publication (et toutes les autres publications pertinentes) avant de l'installer ou de l'utiliser.

Afin de réduire au minimum le risque d'éventuels problèmes de sécurité, vous devez respecter tous les codes locaux et nationaux applicables régissant l'installation et le fonctionnement de votre équipement. Ces codes diffèrent d'une région à l'autre et, habituellement, évoluent au fil du temps. Il vous incombe de déterminer les codes à respecter et de vous assurer que l'équipement, l'installation et le fonctionnement sont conformes aux exigences de la version la plus récente de ces codes.

Vous devez, à tout le moins, respecter toutes les sections applicables du Code national de prévention des incendies, du Code national de l'électricité et des codes de la National Electrical Manufacturer's Association (NEMA). Des organismes de réglementation ou des services gouvernementaux locaux peuvent également vous aider à déterminer les codes ainsi que les normes à respecter pour assurer une installation et un fonctionnement sûrs.

L'omission de respecter la totalité des codes et des normes applicables peut entraîner des dommages à l'équipement ou causer de graves blessures au personnel. Nous ne garantissons pas que les produits décrits dans cette publication conviennent à votre application particulière et nous n'assumons aucune responsabilité à l'égard de la conception, de l'installation ou du fonctionnement de votre produit.

Nos produits ne sont pas insensibles aux défaillances et ne sont ni conçus ni fabriqués pour l'utilisation ou la revente en tant qu'équipement de commande en ligne dans des environnements dangereux nécessitant une sécurité absolue, par exemple, l'exploitation d'installations nucléaires, les systèmes de navigation aérienne ou de communication, le contrôle de la circulation aérienne, les équipements de survie ou les systèmes d'armes, pour lesquels la défaillance du produit peut provoquer la mort, des blessures corporelles ou de graves dommages matériels ou environnementaux («activités à risque élevé»). La société AutomationDirect nie toute garantie expresse ou implicite d'aptitude à l'emploi en ce qui a trait aux activités à risque élevé.

Pour des renseignements supplémentaires touchant la garantie et la sécurité, veuillez consulter la section Modalités et conditions de notre documentation. Si vous avez des questions au sujet de l'installation ou du fonctionnement de cet équipement, ou encore si vous avez besoin de renseignements supplémentaires, n'hésitez pas à nous téléphoner au 770-844-4200.

Cette publication s'appuie sur l'information qui était disponible au moment de l'impression. À la société AutomationDirect, nous nous efforçons constamment d'améliorer nos produits et services. C'est pourquoi nous nous réservons le droit d'apporter des modifications aux produits ou aux publications en tout temps, sans préavis ni quelque obligation que ce soit. La présente publication peut aussi porter sur des caractéristiques susceptibles de ne pas être offertes dans certaines versions révisées du produit.

Marques de commerce

La présente publication peut contenir des références à des produits fabriqués ou offerts par d'autres entreprises. Les désignations des produits et des entreprises peuvent être des marques de commerce et appartiennent exclusivement à leurs propriétaires respectifs. AutomationDirect nie tout intérêt dans les autres marques et désignations.

Copyright© 2025, AutomationDirect.com® Incorporated
Tous droits réservés

Nulle partie de ce manuel ne doit être copiée, reproduite ou transmise de quelque façon que ce soit sans le consentement préalable écrit de la société AutomationDirect.com® Incorporated. AutomationDirect conserve les droits exclusifs à l'égard de tous les renseignements contenus dans le présent document.

ProductivityCodesys User Manual



Please include the Manual Number and the Manual Issue, both shown below, when communicating with Technical Support regarding this publication.

Manual Number: P2CDS-USER-M
Issue: 1st Edition, Rev. C
Issue Date: 10/29/2025

Publication History		
Issue	Date	Description of Changes
1st Edition	1/2024	Original
Rev. A	6/2024	Updated supported modules tables.
Rev. B	01/2025	Updated USB-RS232 cable to USB-RS232-1
Rev. C	10/2025	Updated P2CDS-622 EtherNetIP data.

TABLE OF CONTENTS

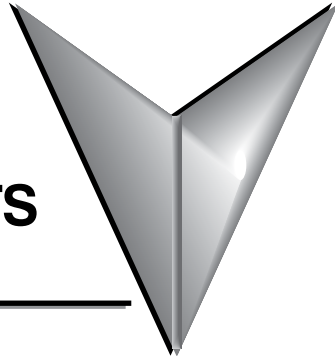

In This Manual

Chapter 1 - Getting Started	1-1
Introduction	1-2
Purpose of this Manual	1-2
Intended Use of This Product	1-2
Benefits of P2CDS-622 with CODESYS Software	1-3
Conventions Used	1-4
Key Topics for Each Chapter.....	1-4
Important Online Resources	1-5
P2CDS-622 System	1-6
Preparation.....	1-6
1. CODESYS IDE Install	1-6
IEC 61131-3 Supported Editor Types:.....	1-7
Install Hardware	1-8
Apply Power to CPU	1-11
Develop HMI Screens directly in the CODESYS Development Environment	1-12
Chapter 2 - Specifications	2-1
P2CDS-622 CPU.....	2-2
P2CDS-622 CPU Features	2-4
P2CDS-622 CPU Programmable RS232/485 Ports.....	2-5
P2CDS-622 CPU Ethernet Ports	2-7
P2CDS-622 CPU USB Type C Programming Port	2-8

Table of Contents

P2CDS-622 CPU microSD Slot.....	2-9
microSD Slot.....	2-9
P2CDS-622 CPU Battery Installation	2-10
Battery (Optional)	2-10
I/O Modules Overview	2-11
P2CDS-622 Wiring, Installation and Safety	2-14



GETTING STARTED



CHAPTER 1

In This Chapter...

Introduction	1-2
Purpose of this Manual	1-2
Intended Use of This Product	1-2
Benefits of P2CDS-622 with CODESYS Software	1-3
Conventions Used.....	1-4
Key Topics for Each Chapter.....	1-4
Important Online Resources	1-5
P2CDS-622 System	1-6
Preparation.....	1-6
1. CODESYS IDE Install	1-6
2. P2CDS-622 Firmware Install.....	1-6
3. System Requirements and Installation	1-6
4. Installation.....	1-7
5. PLC On the Network	1-7
IEC 61131-3 Supported Editor Types:.....	1-8
Install Hardware	1-9
Apply Power to CPU.....	1-12
Develop HMI Screens directly in the CODESYS Development Environment	1-13

Introduction

Purpose of this Manual

Thank you for purchasing the AutomationDirect ProductivityCODESYS CPU. The user manual provides information that will help you install, set up, troubleshoot, and maintain your ProductivityCODESYS project.

The manual includes information that is critical to the safety of the personnel, who will install and use the controller, and to the machinery, processes, and equipment controlled by the P2CDS-622 CPU.

The manual also includes important information about power and signal wiring, mounting the CPU and I/O modules, and configuring the system.

Intended Use of This Product

The P2CDS-622 is a Productivity® 2000 format CPU allowing implementation of the IEC-61131-3 programming languages through the use of CODESYS software. The CODESYS system is the basis of a comprehensive suite that covers the entire software side of automation including Industrial Internet of Things (IIoT), communication, Soft PLC, drives, and visualization. It offers users practice-oriented, integrated solutions for the convenient configuration of automation applications and provides practical support for accomplishing daily tasks.

Users can develop a human machine interface (HMI) and a PLC application in one IEC 61131-3 development system. The CODESYS Visualization tool has proven itself in thousands of industrial machine and plant applications around the world.

Any use other than described in this manual is not permitted, as it may expose the user to possible harm and/or damage to the device or connected equipment.

The P2CDS-622 CPU must not be altered or modified. The safety instructions as well as the maximum permissible ambient conditions and operating parameters are given in Chapter 2 "Specifications".

This instruction manual is meant to be read thoroughly while being mindful of safe and proper operation. It contains important information on mounting, operating and handling the P2CDS-622.

Benefits of P2CDS-622 with CODESYS Software

Choose your functionality

- Visualization and communication with other systems
- Testing, debugging, analysis, version control
- Fieldbus and I/O connection

Choose between extensive Industry 4.0 possibilities

- Administration platform for your controllers and projects
- Remote maintenance and remote access
- Data logging and display
- Connection to external systems for Big Data/Machine Learning/AI
- Static code analysis for early detection of potential programming errors
- Profiling/test automation tools for facilitated acceptance according to EN13849 PL_d
- Creation of graphical user interfaces
- Remote access for maintenance, diagnostics, monitoring, and debugging via the associated Industry 4.0 platform
- Cloud-supported analysis of operating data
- Connection to public cloud systems via MQTT for predictive maintenance by means of AI algorithm

For Building Control Systems (Local and Global)

- Expandable panel controls, thanks to being manufacturer independent and widely used open systems
- Industry standard protocols such as Modbus
- Engineering software for the creation of logical links and sequences
- Convenient graphical configuration of aggregates/units for trade-specific application
- Worldwide available visualizations for monitoring and operation
- Connection of external APIs and cloud providers through IoT clients for efficient energy management, e.g. at the energy exchange
- Analysis of incoming measurement data in the cloud and presentation of the results on configurable dashboards

Conventions Used



NOTE: When you see the “note pad” icon in the left-hand margin, the paragraph to its immediate right will be a special note. Notes represent information that may make your work quicker or more efficient. The word **NOTE** in boldface will mark the beginning of the text.



WARNING: When you see the “exclamation point” icon in the left-hand margin, the paragraph to its immediate right will be a warning. This information could prevent injury, loss of property, or even death in extreme cases. Any warning in this manual should be regarded as critical information that should be read in its entirety. The word **WARNING** in boldface will mark the beginning of the text.

Key Topics for Each Chapter

The beginning of each chapter will list the key topics that can be found in that chapter.

GETTING STARTED	CHAPTER 1
In This Chapter...	
Introduction.....	1-2
Purpose of this Manual.....	1-2
About Getting Started.....	1-2
Online Help Files and Other Documentation.....	1-2
Technical Support.....	1-2
Conventions Used.....	1-3
Key Topics for Each Chapter.....	1-3
Before you begin.....	1-4
Productivity Suite System Requirements.....	1-5
Managing Software.....	1-6

Important Online Resources

Download the latest version of the CODESYS Software from the CODESYS website:

<https://us.store.codesys.com/codesys.html>



NOTE: *USB or Ethernet cable is also required for communications between PC and CPU.*

Follow steps on site to log-in and download the CODESYS software system.



NOTE: *CODESYS supports the software from their website. Once you establish a user account you will be able to receive support from CODESYS.*

Access to ADC Community based help for your ProductivityCODESYS projects is available from our website: [P2CDS-622](#). Here you will find access to our RTD site.

A variety of other useful information about the ProductivityCodesys I/O modules, as well as code for example tasks and more is available.

In addition, all supported Productivity2000 series power supplies and I/O modules include a convenient installation insert.

P2CDS-622 System

Preparation

The installation steps are as follows:

1. Install the CODESYS IDE on your PC.
2. Install the latest P2CDS-622 Firmware image file.
3. Install the P2CDS-622 Device Package (.package) file.
4. Configure the Ethernet ports
5. Install the IIoT Library file (optional) if needed.

CODESYS IDE Install

- The first task is to load and install the CODESYS software. This can be found at the following CODESYS Store location:
<https://us.store.codesys.com/codesys.html>
- The remaining steps can be found at this RTD site:
The RTD link: <https://docs.codesys-p2cds622.com/en/latest/Getting%20Started/preparation.html>

There you will find all the information for getting your P2CDS-622 system up and running.

P2CDS-622 System, cont'd

IEC 61131-3 Supported Editor Types:

- Functional Block Diagram (FBD)
- Structured Text (ST)
- Sequential Function Charts (SFC)
- Ladder Diagram (LD)

CODESYS (and P2CDS-622) also supports Continuous Function Charts (CFC) programming, in addition to the aforementioned IEC61131-3 programming types.



NOTE: See Appendix A for an explanation of each Editor Type.

For most systems such as EtherNet/IP™, portable CODESYS libraries implement the protocol stack for the fieldbus. Additionally, CODESYS offers libraries for Modbus communication (TCP or serial).

Benefits:

- Identical usage of the protocol stack for different fieldbus technologies
- Compiling / linking the stack dynamically to the application
- No external software tool required
- For Industrial Ethernet systems: No additional hardware required - a standard Ethernet port on the device for EtherNet/IP or Modbus TCP is sufficient
- Seamless integration of the configurator into the CODESYS Development System
- Comprehensive integrated diagnostic functions
- Integrated Commissioning and Diagnosis Functionality

Commissioning of the fieldbus system can be carried out with the Online Config Mode even without an available application. Numerous functions for communication diagnostics are available in the user interface and application, such as event loggers or diagnostic information in the device tree and in the application code.

Install Hardware

The Productivity® 2000 CPU system components snap together to form a configured CPU in minutes. See Chapter 5, Installation and Wiring, for more detailed hardware installation information. What follows are the basic steps:

1. Install power supply in the base and engage locking tab.

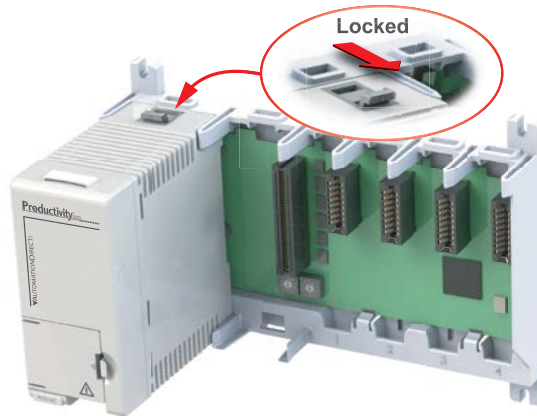

2. Install CPU in the base and engage locking tab.

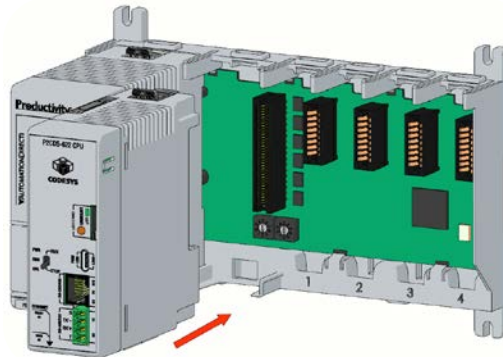

3. Install I/O Modules and engage locking tabs.

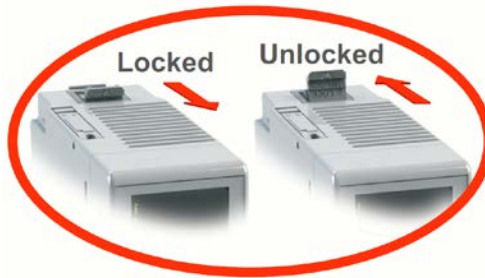

4. Connect appropriate wiring to the power supply (P2-01AC) and I/O (P2-08TRS) module in this example.

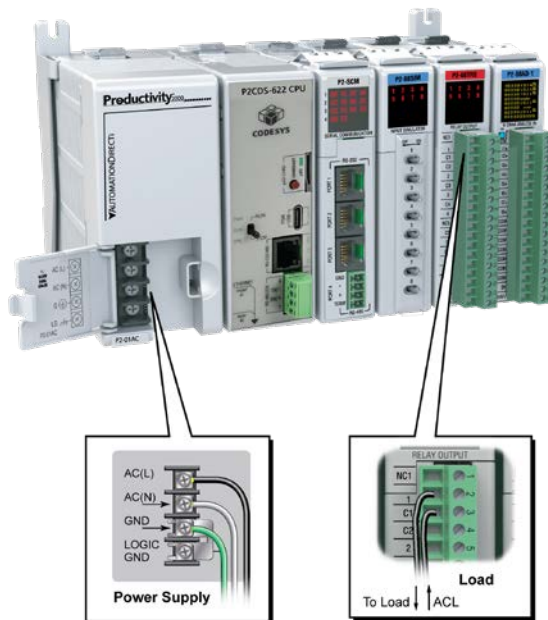

The power supply and load are connected through separate AC current sources.

5. Connect USB cable. Programming connections may be via Ethernet cable or USB. P2CDS-622 CPUs have a USB type C programming port.



Apply Power to CPU

Ensure proper wiring and the correct voltage is available before connecting wiring to the power supply. Once this is verified, connect power to the power supply. Once power is applied, the CPU will perform a self-evaluation and verification.



P2-01AC

100-240 VAC

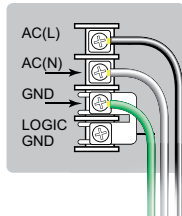

P2-01DCAC

12-24 VDC

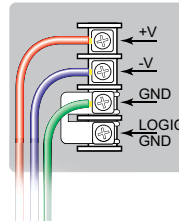

24 VAC

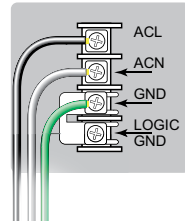

P2-01DC

P2-01DC: 24-48 VDC

P2-02DC: 24VDC

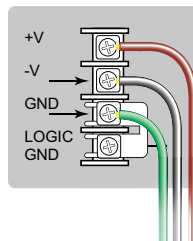

P2-02DC

Develop HMI Screens directly in the CODESYS Development Environment

CODESYS Development System comes with an integrated visualization editor, allowing HMI development without the need for separate software interface.

Design visualization screens with direct access to all application variables thanks to the full integration in the IEC 61131-3 Development System, with no tag list comparison required.

Visualization screens can be for machine and plant operation, for testing and commissioning, and can be accessed simultaneously by any system with an internet browser (PCs, tablets, smartphones, etc.).



NOTE: *The P2CDS-622 is an entry level CODESYS PLC that runs on a single 600MHz core. As such, adding complex Visualizations may affect performance.*

SPECIFICATIONS



CHAPTER 2

In This Chapter...

P2CDS-622 CPU.....	2-2
P2CDS-622 CPU Features	2-4
P2CDS-622 CPU Programmable RS232/485 Ports.....	2-5
P2CDS-622 CPU Ethernet Ports	2-7
P2CDS-622 CPU USB Type C Programming Port	2-8
P2CDS-622 CPU microSD Slot.....	2-9
microSD Slot.....	2-9
P2CDS-622 CPU Battery Installation	2-10
Battery (Optional)	2-10
I/O Modules Overview	2-11
P2CDS-622 Wiring, Installation and Safety	2-14

P2CDS-622 CPU

The P2CDS-622 CPU is a Productivity2000-series compatible CPU. It is compatible with all Productivity2000 modules, with the exception of P2-RS and P1-RX remote slaves, PS-AMC motion controllers, and the following Modules: P2-HSI, P2-HSO, P2-02HSC, and P2-SCM.

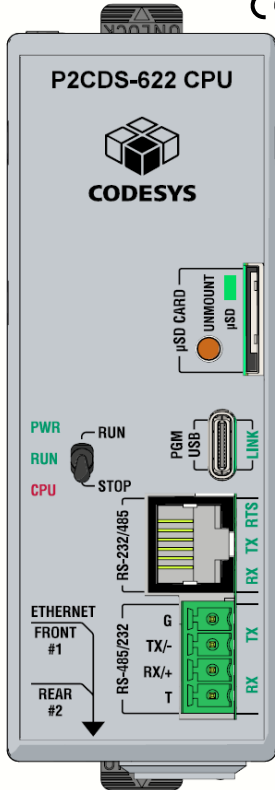

CPU Specifications	
User Memory	50MB (Includes program, data and documentation)
Memory Type	Flash and Battery Backed RAM
Retentive Memory	1MB (Retain 800KB / Retain-Persistent 200KB)
Scan Time	550us (5K Boolean Logic)
Interfaces	<p>USB IN: USB 2.0 (single port), Program, Monitor, Debug, Firmware Update</p> <p>ETHERNET: Two independent 10/100Mbps RJ-45 connectors</p> <p>PROTOCOLS: Modbus TCP and RTU Client/Server, EtherNet/IP Scanner/Adapter, MQTT with TLS, Email, SMTP Client</p> <p>VISUALIZATION: "WebVisu" (Web Server)</p> <p>RS232/485: RJ12 connector</p> <p>RS232/485: 4-position Terminal Block</p>
Data Logging	microSD card slot
Hardware Topologies	<p>Four (4) Base Groups: Four (4), seven (7), eleven (11), and fifteen (15) slot bases</p> <p>Supported Modules: All P2 Discrete Input and Output modules, all P2 Analog Input and Output modules, P2-04PWM</p> <p>Unsupported Modules: Remote Slaves (P1-RX, P2-RS) and P2-HSO, P2-HSI, P2-02HSC, and P2-SCM modules.</p>
IEC 61131-3 Supported Editor Types	<p>Functional Block Diagram (FBD)</p> <p>Structured Text (ST)</p> <p>Sequential Function Charts (SFC)</p> <p>Ladder Diagram (LD)</p> <p>Continuous Function Chart (CFC)</p>
Real Time Clock Accuracy	<p>±2s per day typical at 25°C</p> <p>±10s per day maximum at 60°C</p>

IMPORTANT!



Hot-Swapping Information

Note: This device cannot be Hot Swapped.

P2CDS-622 CPU Features

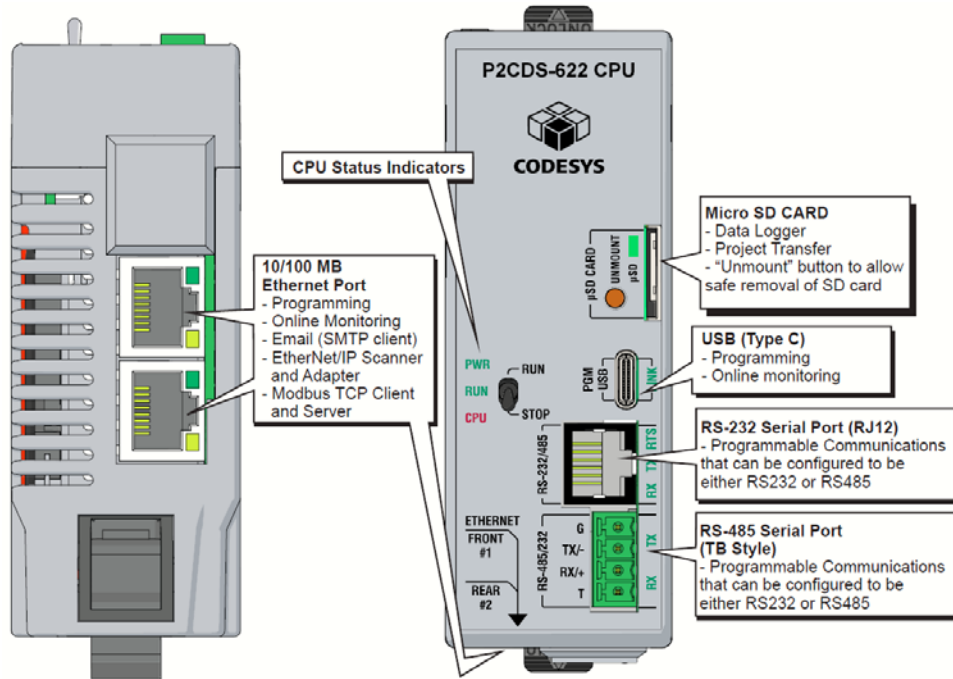

P2CDS-622 CPU Programmable RS232/485 Ports

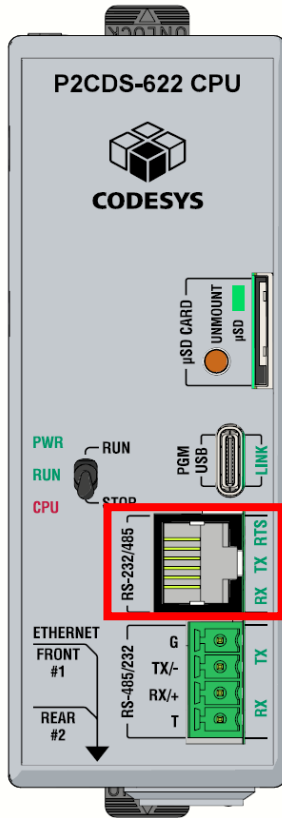

The [P2CDS-622](#) CPU RJ12 style connector and a 4-position terminal may each be programmed for RS232 or RS485 connections. These ports may be used for:

- Modbus RTU Master connections
- Modbus RTU Slave connections
- ASCII full or half duplex communications
- Custom Protocol Incoming and Outgoing communications

RS232 Specifications	
TXD	RS232 Transmit output
RXD	RS232 Receive input
RTS	Handshaking output for modem control (RJ12 Only)
GND	Logic ground
Maximum Output Load (TXD/RTS)	3 kΩ, 1000 pF
Minimum Output Voltage Swing	±5 V
Output Short Circuit Protection	±15 mA

RJ12 Connector Specifications	
Description	Programmable RS232/485 Port - Non-isolated RS232 DTE port connects the CPU as a Modbus/ASCII master or slave to a peripheral device. Includes ESD and built in surge protection - Non-isolated RS485 port connects the CPU as a Modbus/ASCII master or slave to a peripheral device. Includes ESD/EFT protection and automatic echo cancellation when transmitter is active
Data Rates	Selectable, 1200, 2400, 4800, 9600, 19200, 33600, 38400, 57600, and 115200 baud
+5 V Cable Power	210 mA maximum at 5 V, ±5%. Reverse polarity and overload protected.
Port Status LED	Green LED illuminated when active for TXD, RXD and RTS
Cable Options	EA-MG-PGM-CBL D2-DSCBL USB-RS232-1 with D2-DSCBL FA-CABKIT

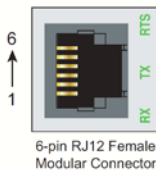

Pin #	RS232	RS485
6	GND	GND
5	RTS	
4	TXD	TXRX-
3	RXD	TXRX+
2	+5V, 210mA	Do not connect
1	GND	GND

P2CDS-622 CPU Programmable RS485/232 Ports

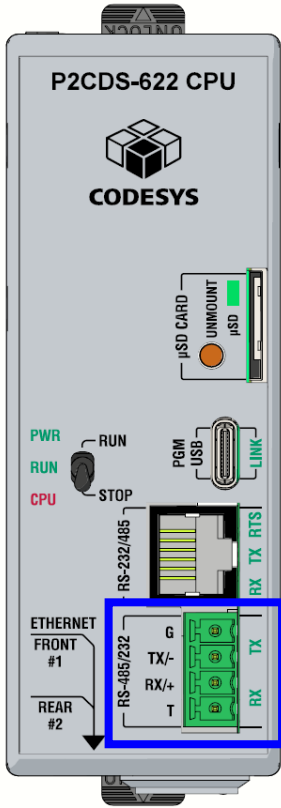

RS485 Specifications	
TXD+/RXD+	RS485 transceiver high
TXD-/RXD-	RS485 transceiver low
GND	Logic Ground
Input Impedance	19 kΩ
Termination Resistance (TB Jumper wire "T" to "+")	120 Ω. To use, add jumper between pin 1 and pin 2. Resistor is internally connected between pins 1 and 3.
Maximum Load	50 transceivers, 19 kΩ each, 60Ω termination
Output Short Circuit Protection	±250 mA, thermal shut-down protection
Electrostatic Discharge Protection	Contact ±4 KV, Air ±8 KV per IEC61000-4-2 (Cable is installed for testing)
Electrical Fast Transient Protection	±1 V per IEC61000-4-4
Minimum Differential Output Voltage	1.5 V with 60 Ω load
Fail Safe Inputs	Logic high input state if inputs are connected
Maximum Common Mode Voltage	-7.5 V to 12.5 V

Terminal Block Specifications	
Description	Programmable RS485/232 Port - Non-isolated RS232 DTE port connects the CPU as a Modbus/ASCII master or slave to a peripheral device. Includes ESD and built in surge protection - Non-isolated RS485 port connects the CPU as a Modbus/ASCII master or slave to a peripheral device. Includes ESD/EFT protection and automatic echo cancellation when transmitter is active
Data Rates	Selectable, 1200, 2400, 4800, 9600, 19200, 33600, 38400, 57600, and 115200 baud
Port Status LED	Green LED illuminated when active for TXD and RXD
Cable Options	Go to AutomationDirect.com for RS232 and 485 cable selection.

4 Position Terminal Block

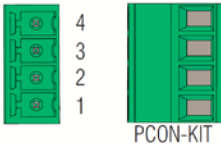

Pin #	RS232	RS485
4	GND	GND
3	TXD	TXRX-
2	RXD	TXRX+
1	Do not connect	TERMINATE

P2CDS-622 CPU Ethernet Ports

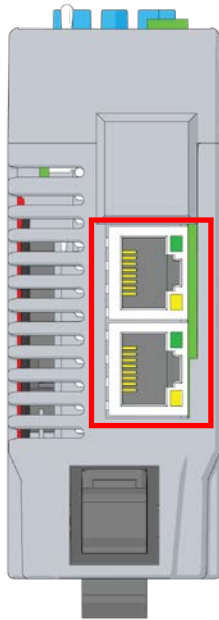

P2CDS-622 Bottom View

Ethernet Port (RJ45 style connectors on bottom of CPU) used for:

- Connection to a PC running the programming software
- Modbus TCP Client (32 Servers) connections (Modbus requests sent from the CPU)
- Modbus TCP Server (16 Clients) connections (Modbus requests received by the CPU)
- EtherNet/IP Scanner (64 Adapters)
- EtherNet/IP Adapter (8 scanners)
- Outgoing E-mail
- MQTT Client (4 brokers)
- Rear port does not have Default Gateway or DNS capability.

Ethernet Specifications	
Port Name	ETHERNET
Description	Standard transformer isolated Ethernet port with built-in surge protection for programming, online monitoring, firmware, MQTT, Email (SMTP client), Modbus/TCP client/server connections (fixed IP or DHCP) and EtherNet/IP Scanner/Adapter connections.
Transfer Rate	RJ45 Yellow LED Off = 10Mbps / On = 100 Mbps
Port Status LED	RJ45 Green LED Solid when network LINK is established. Flashes when port is active (ACT).

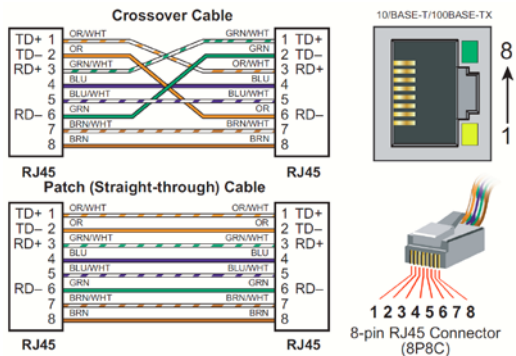

P2CDS-622 CPU USB Type C Programming Port

The P2CDS-622 CPU has a standard USB C Slave input for programming and online monitoring, with built-in surge protection. Capable of 480 Mbps.

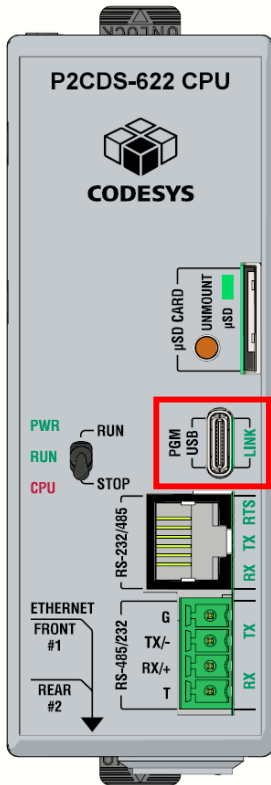

USB Type C Specifications

Port Name	USB C
Description	Standard USB C Slave input for programming and online monitoring, with built-in surge protection.
Transfer Rate	480 Mbps
Port Status LED	Green LED is illuminated when LINK is established to programming software.
Cables	USB Type A to USB Type C: 6 ft cable part # USB-CBL-AC6

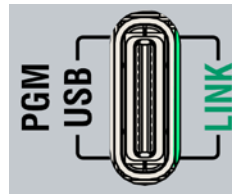

P2CDS-622 CPU microSD Slot

microSD Slot

The SD Card can be used for the Data Logging in the project or program transfer.

When an SD Card is inserted, the “μSD” LED will flash green a few times then stay on steady green.

The “Unmount” button is pressed prior to removing the SD card. When pressed, the μSD port LED flashes momentarily during the unmounting and then will be off indicating it is safe to remove the SD Card.

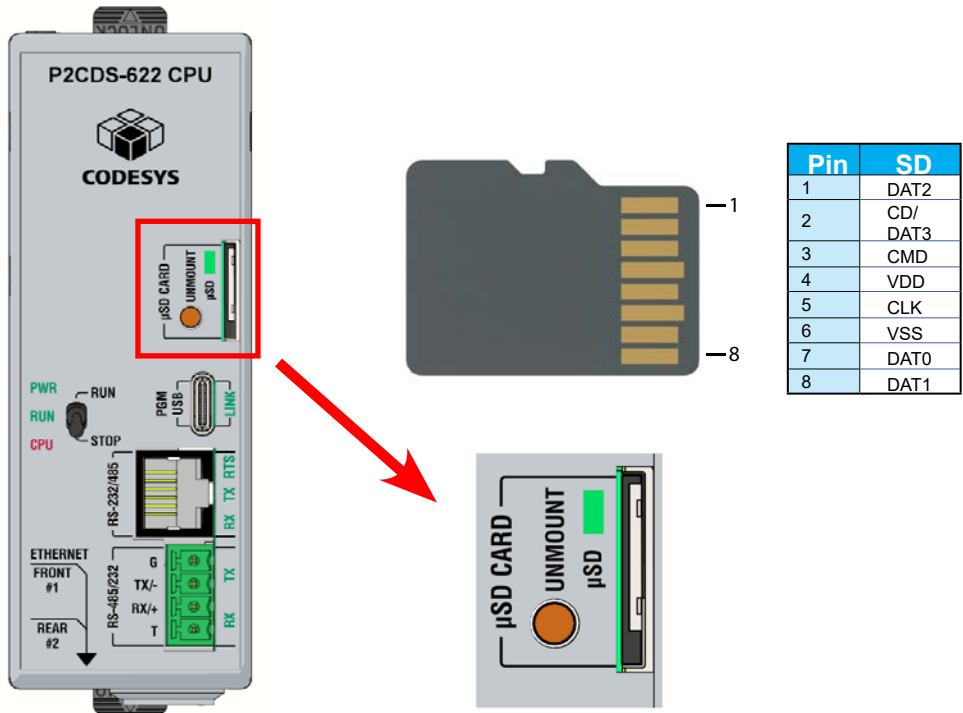

microSD Specifications				
Port Name	microSD			
Description	Standard microSD socket for data logging or program transfer			
Maximum Card Capacity	32 GB			
Transfer Rate (ADATA microSDHC Class 4 memory card)	Mbps	Minimum	Typical	Maximum
	Read	14.3	14.4	14.6
	Write	4.8	4.9	5.1
Port Status LED	Green LED is illuminated when card is inserted and detected			

P2CDS-622 CPU Battery Installation

Battery (Optional)

A battery is included with the CPU module but is not installed. The battery may be installed in order to retain the Time and Date along with any tagname values that are set up as retentive. The battery is not needed for program backup.

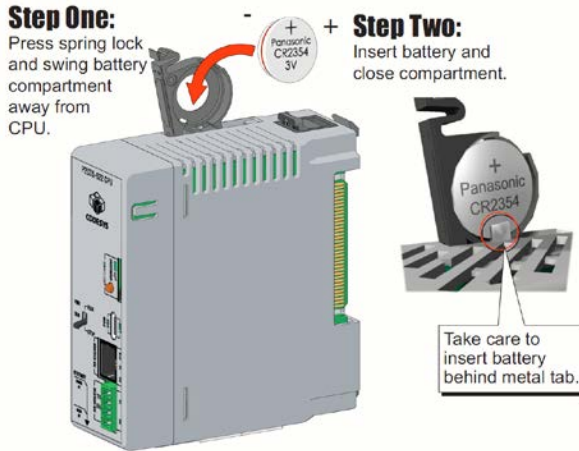

Battery (Optional)

D2-BAT-1

Coin type, 3.0 V Lithium battery, 560mA, battery number CR2354

Note: Although not needed for program backup, an uninstalled battery is included with the P2CDS-622. Install this battery if you want the CPU to retain the Time and Date along with any Tagname values that you have configured as retentive.

I/O Modules Overview

A variety of analog I/O modules from our Productivity2000 line are available for use with the P2CDS-622 CPU. Please refer to Productivity2000 manual [Chapter 2](#) for detailed technical specifications.

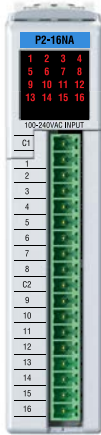

Discrete Input Modules

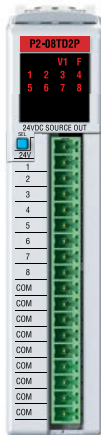

Discrete Output Modules

Productivity [®] 2000 I/O Modules Supported		
Part Number	Number of Points	Description
Discrete Input Modules		
P2-08SIM	8	Input Simulator Module
P2-08ND3-1	8	Sinking/Sourcing 12–24 VDC
P2-16ND-TTL	16	Sinking/Sourcing 5 VDC
P2-16ND3-1	16	Sinking/Sourcing 12–24 VDC
P2-32ND3-1	32	Sinking/Sourcing 12–24 VDC
P2-08NE3	8	Sinking/Sourcing 24 V AC/DC
P2-16NE3	16	Sinking/Sourcing AC/DC
P2-32NE3	32	Sinking/Sourcing 24 V AC/DC
P2-08NAS	8	AC Isolated 100–120 VAC
P2-16NA	16	AC Isolated 100–240 VAC
Discrete Output Modules		
P2-08TD1S	8	Isolated Sinking
P2-08TD2S	8	Isolated Sourcing
P2-15TD1	15	Sinking
P2-15TD2	15	Sourcing
P2-08TD1P	8	Sinking, Protected
P2-08TD2P	8	Sourcing, Protected
P2-16TD-TTL	16	Sinking/Sourcing 5VDC
P2-16TD1P	16	Sinking, Protected
P2-16TD2P	16	Sourcing, Protected
P2-32TD1P	32	Sinking, Protected
P2-32TD2P	32	Sourcing, Protected
P2-08TAS	8	Isolated AC
P2-16TA	16	AC Output
P2-06TRS	6	Isolated Relay
P2-08TRS	8	Isolated Relay
P2-16TR	16	Relay Output

I/O Modules Overview, continued

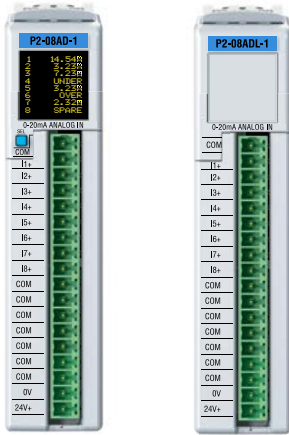

Analog Input Modules

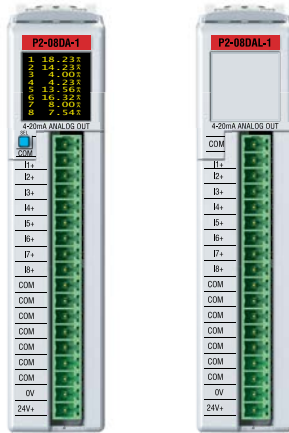

Analog Output Modules

Productivity [®] 2000 I/O Modules Supported		
Part Number	Number of Points	Description
Analog Input Modules		
P2-04AD	4	Voltage/Current
P2-04AD-1	4	Current
P2-04AD-2	4	Voltage
P2-08AD-1	8	Current
P2-08AD-2	8	Voltage
P2-08ADL-1*	8	Current
P2-08ADL-2*	8	Voltage
P2-16AD-1	16	Current
P2-16AD-2	16	Voltage
P2-16ADL-1*	16	Current
P2-16ADL-2*	16	Voltage
P2-06RTD	6	RTD Input
P2-08THM	8	Thermocouple Input
P2-08NTC	8	Thermistor Input
Analog Output Modules		
P2-04DA	4	Voltage/Current
P2-04DA-1	4	Current
P2-04DA-2	4	Voltage
P2-04DAL-1*	4	Current
P2-04DAL-2*	4	Voltage
P2-08DA-1	8	Current
P2-08DA-2	8	Voltage
P2-08DAL-1*	8	Current
P2-08DAL-2*	8	Voltage
P2-16DA-1	16	Current
P2-16DA-2	16	Voltage
P2-16DAL-1*	16	Current
P2-16DAL-2*	16	Voltage

I/O Modules Overview, continued

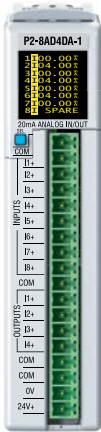

**Combination
Analog I/O Module**

Productivity® 2000 I/O Modules Supported		
Part Number	Number of Points	Description
Analog Combination Modules		
P2-08AD4DA-1	8/4	Analog Input/Output (Current)
P2-8AD4DA-2	8/4	Analog Input/Output (Voltage)

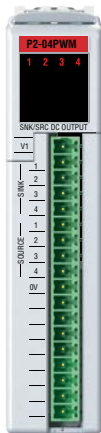

Specialty Module

Specialty Modules	
Part Number	Description
<i>P2-04PWM</i>	High-speed pulse-width modulation



NOTE: Unsupported Modules: Remote Slaves (P2-RS) and Intelligent modules (P2-HSO, P2-HSI, P2-02HSC, and P2-SCM).

P2CDS-622 Wiring, Installation and Safety

P2CDS-622 is supported by Productivity2000 system hardware and has the same installation and safety guidelines. Please refer to [Chapter 5 "Installation and Wiring"](#) in the P2000 user manual for details concerning installation procedures and wiring suggestions.