

# **BRX MOTION CONTROL, COMMUNICATIONS & SPECIALTY MODULES**

---



## **In This Chapter...**

Overview.....	9-2
Module Types.....	9-2
Wiring Termination Options.....	9-4
General Specifications.....	9-6
Dimensional Information.....	9-6
Module Installation .....	9-7
Module Configuration.....	9-8
BX-HSIO1 and BX-HSIO2 High Speed Input/Output Modules .....	9-9
BX-HSIO4 High Speed Input/Output Module.....	9-11
BX-HSIOx High Speed I/O Modules Setup.....	9-16
BX-SERIO Serial Communications Module .....	9-17
BX-SERIO-2 Serial Communications Module .....	9-20
BX-SERIO-4 Serial Communications Module .....	9-23
BX-APAD Active Filling Module .....	9-26

## Overview

One key feature of the BRX platform is its ability to easily expand its capability to fit your application solution. One of the ways the BRX platform can do this is by using expansion modules that conveniently “snap-on” to the side of any BRX MPU.

The motion control, communications and specialty expansion modules currently include high-speed I/O modules, serial communications modules and an active padding module.

## Module Types

### High-Speed Input/Output Modules

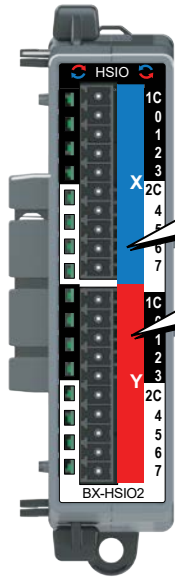
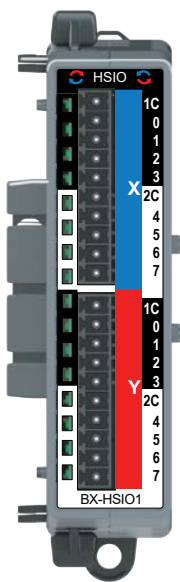

Three (3) high-speed input/output modules are available, with eight inputs and eight outputs. High-speed I/O module faceplates have blue and red terminal bar sections to distinguish input and output terminals, respectively, and have the  symbol to signify high-speed I/O.

Blue Label for Input

Red Label for Output

The table below shows the high-speed I/O modules and their input/output types.

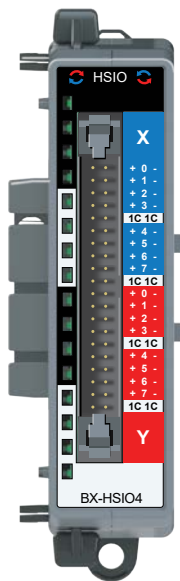

High-Speed Input/Output Module			
Identifier	HSIO1	HSIO2	HSIO4
Input Type	12–24 VDC Sink/Source	12–24 VDC Sink/Source	2.5–5 VDC Sink/Source
Number of Inputs	8	8	8
Output Type	12–24 VDC Sinking	12–24 VDC Sourcing	5VDC Differential
Number of Outputs	8	8	8
Max Frequency	250kHz	250kHz	2MHz

## Serial Communications Modules

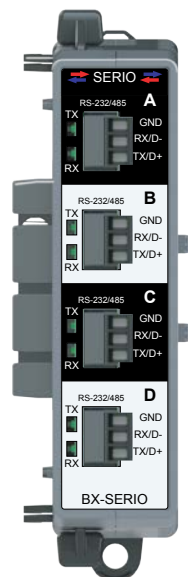

Three (3) serial communications modules are available, with four serial ports. Serial communications module faceplates have black and white terminal sections to distinguish serial terminals, and have the  symbol to signify serial I/O. The table below shows the serial I/O module and its port types.

Serial Input/Output Module			
Identifier	SERIO	SERIO-2	SERIO-4
Port Type	RS-232 / RS-485	RS-232 with Flow Control	RS-422
Number of Ports	4	4	4

## Active Padding Module

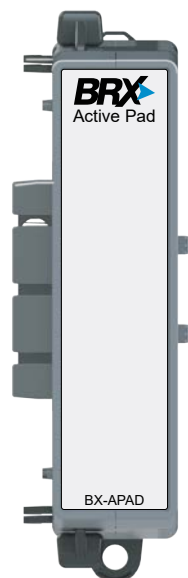

One (1) active padding module is available. This module emulates other BRX modules in the I/O configuration of a BRX system. It is configured in software to emulate the address space of a specific BRX module. The padding module can be used to reserve address space so that addressing in subsequent modules does not change if a module is removed.

## Wiring Termination Options

The BRX high-speed input/output expansion modules ship without wiring terminal blocks. This allows you to select the termination style that best fits your application. There are several wiring options available, including screw type terminal connectors with either 90° or 180° (straight) termination angle, and a 180° (straight) spring clamp type connector. The BX-HSIO1 and HX-HSIO2 high-speed I/O modules are not compatible with the **ZIPLink** Wiring System. The BX-HSIO4 high-speed I/O module **requires** the **ZIPLink** Wiring System.



**NOTE:** The BX-HSIO4 high-speed I/O module requires the ZIPLink Wiring System.

The BRX serial communications expansion modules ship with four (4) removable screw terminal connectors. Replacement terminal connectors are available.

### Terminal Block Connectors

The terminal block connectors for the high-speed I/O modules include (2) 10-pin 3.81-mm connectors in kits as a single part number. Replacement terminal block connectors for the serial communications module are sold individually.

Terminal block kit part numbers and connector specifications are listed in the following table.

Terminal Block Specifications						
Module	BX-HSIO1/BX-HSIO2			BX-SERIO	BX-SERIO-2	BX-SERIO-4
Part Number	BX-RTB10	BX-RTB10-1	BX-RTB10-2	BX-RTB03S	BX-RTB05S	
Connector Type	Screw Type 90 degree	Spring Clamp Type 180 degree	Screw Type 180 degree	Screw Type 90 degree	Screw Type 90 degree	
Wire Exit	180 degree	180 degree	180 degree	180 degree	180 degree	
Pitch	3.81 mm	3.81 mm	3.81 mm	3.5 mm	3.5 mm	
Screw Size	M2	N/A	M2	M2	M2	
Screw Torque Recommended	<1.77 lb·in (0.2 N·m)	N/A	<1.77 lb·in (0.2 N·m)	<1.77 lb·in (0.2 N·m)	<1.77 lb·in (0.2 N·m)	
Screwdriver Blade Width	2.5 mm	2.5 mm	2.5 mm	2.5 mm	2.5 mm	
Wire Gauge (Single Wire)	28–16 AWG	26–18 AWG	30–16 AWG	28–16 AWG	28–16 AWG	
Wire Gauge (Dual Wire)	28–18 AWG	30–20 AWG (Dual Wire Ferrule Required)	30–18 AWG	28–16 AWG	28–16 AWG	
Wire Strip Length	0.24 in (6mm)	0.35 in (9mm)	0.26 in (6.5 mm)	0.24 in (6mm)	0.24 in (6mm)	
Equiv. Dinkle P/N	EC381V-10P-BK	ESC381V-10-BK	EC381F-10P-BK	EC350V-03P-BK	EC350V-05P-BK	



BX-RTB10 Kit



BX-RTB10-1 Kit



BX-RTB10-2 Kit



BX-RTB03S Kit



BX-RTB05S Kit



**NOTE:** Four (4) BX-RTB03S terminal blocks are included with BX-SERIO expansion module.

Four (4) BX-RTB05S terminal blocks are included with BX-SERIO-2 and BX-SERIO-4 expansion modules.

## ***ZIPLink* Wiring System**

BRX digital expansion modules can be quickly connected to convenient ***ZIPLink*** remote terminal blocks for ease of wiring remote I/O devices. Your ***ZIPLink*** selection is dependent on the number of expansion module terminal points. The following tables list the connector options.

<b>16-Point BRX High Speed I/O Expansion Module <i>ZIPLink</i> Selector</b>					
<b>Expansion Module Part No.</b>	<b><i>ZIPLink</i> Module</b>	<b><i>ZIPLink</i> Module Part No.</b>	<b>Qty Needed</b>	<b><i>ZIPLink</i> Cable Part No.</b>	<b>Qty Needed</b>
BX-HSIO4	Feedthrough	ZL-RTB40 (standard) -OR- ZL-RTB40-1 (compact)	1	ZL-BX-CBL40-S ZL-BX-CBL40-1S	1

## General Specifications

All BRX motion control and communications expansion modules have the same general specifications listed in the table below.

General Specifications	
Operating Temperature	0° to 60°C (32° to 140°F)
Storage Temperature	-20° to 85°C (-4° to 185°F)
Humidity	5 to 95% (non-condensing)
Environmental Air	No corrosive gases permitted
Vibration	IEC60068-2-6 (Test Fc)
Shock	IEC60068-2-27 (Test Ea)
Enclosure Type	Open Equipment
Noise Immunity	NEMA ICS3-304
EU Directive	See the "EU Directive" topic in the BRX Help File.

## Dimensional Information

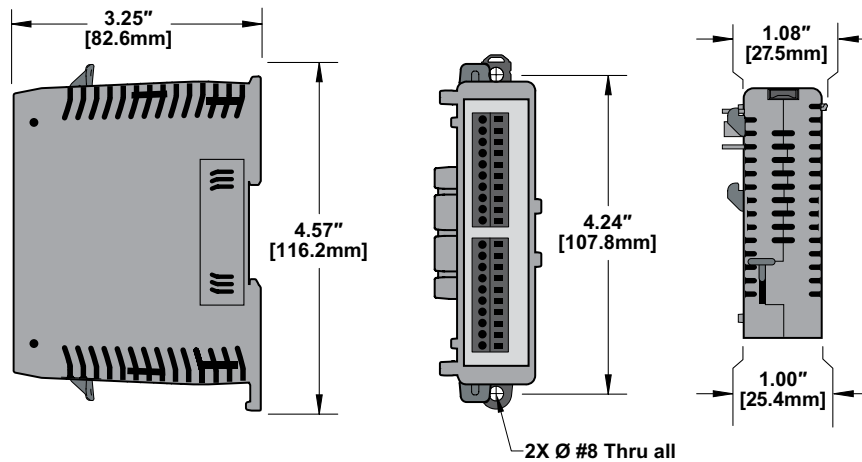

## Module Installation



**WARNING:** Do not apply field power until the following steps are completed. The BRX expansion modules are NOT hot swappable.

To install an expansion module, remove the connector cover on the right side of the MPU or expansion module the new module is to be connected to. Align the expansion connectors, insert the module until you hear a “click”, indicating the module expansion connectors have engaged.

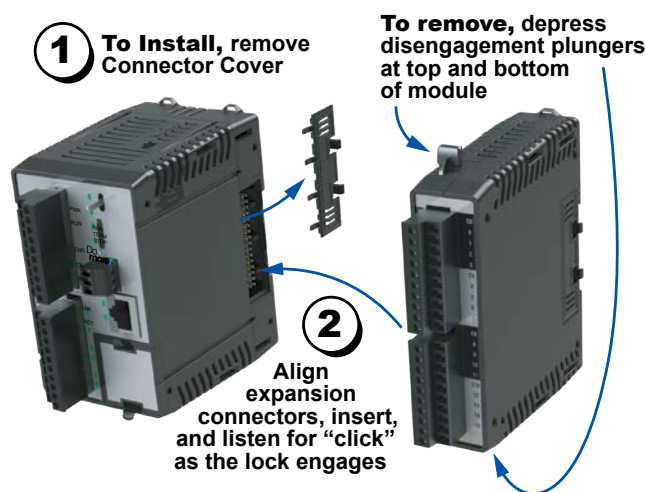

To remove an expansion module locate the two disengagement plungers. One is located at the top of the of the expansion module and a second one at the bottom of the expansion module. Depressing both plungers at the same time will release the locking mechanism and disengage the unit from the system.



**NOTE:** Allow a minimum of 45mm (1.75 in) to the right of MPU chassis or any subsequent expansion modules for mounting and dismounting of the modules.

## Module Configuration

Once the expansion module has snapped in place and is added to the project, it instantly adds additional I/O and features to the MPU with minimal additional setup required.

To configure a newly attached module, load the Do-more! Designer software and connect to the BRX MPU, as discussed in the Do-more! Designer Software Getting Started Guide (DMD-GSG-M) which can be found at <http://support.automationdirect.com/products/domore.html>. A graphical representation of the BRX unit with its attached modules is displayed in the Dashboard of the software.

The screenshot displays the software dashboard with several configuration panels and a central hardware visualization. The top row includes panels for Program, Documentation, Communications, and I/O. The bottom row includes panels for CPU, Memory, and Devices. The central area shows a BRX unit with various modules (HSIO, Interrupts, DI, AIO, DO) and a context menu open over one of the modules, with 'Configure Module' highlighted and a circled '1' next to it.

Program	Documentation	Communications	I/O
<b>View/Edit the Program</b> Code-blocks: 1 Matches PLC, different than disk Do-more Technology Version: 2.0 Program memory used: <1%	<b>Add/Edit Element Documentation</b> Matches PLC, different than disk Documentation memory used: <1%	Modbus/TCP Server: ENABLED Ethernet/IP Server: DISABLED	Ethernet I/O Master: DISABLED I/O Slaves: 0 I/O System Status: GOOD Interrupts Enabled: 1

CPU	Memory	Devices
Connected to 10.1.1.125 BX-DM1E-18ED13 (00 E0 62 30 06 61) PLC is in PROGRAM mode IP Address: 10.1.1.125 OS: 2.0.4 Log Entries: 0 User/85 System Scan Time: 196µs	Change memory configuration Open Cross-Reference View Different than PLC and disk Memory image: 0 regions No forces active Memory allocated: 40%	Add/edit devices 16 devices present Device status: OK

To access the module configuration dialogs, left-click or right-click on the module in the Dashboard and select (1) **Configure Module**. The configuration dialogs for each module are discussed in the corresponding section of this chapter.

# BX-HSIO1 and BX-HSIO2 High Speed Input/Output Modules

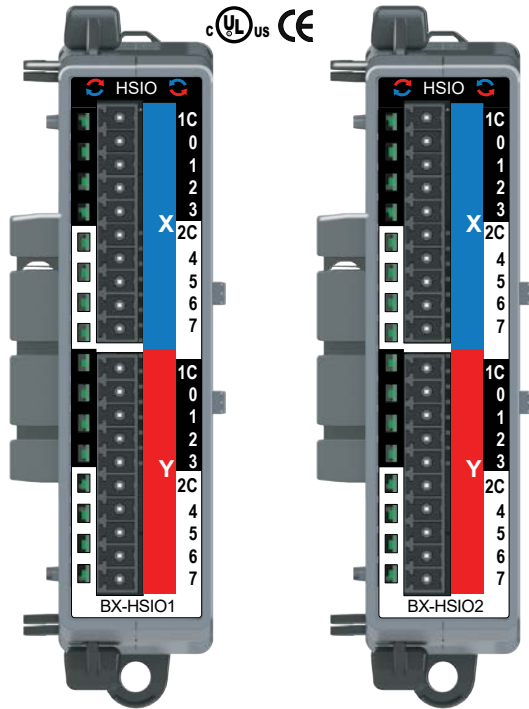

Terminal Blocks Sold Separately



*NOTE: This device does not support ZIPLink Wiring Systems.*



*NOTE: Cannot be used in Remote I/O Bases.*

## IMPORTANT!



### Hot-Swapping Information

**NOTE: This device cannot be Hot Swapped.**

### High Speed Input/Output Wiring

#### BX-HSIO1

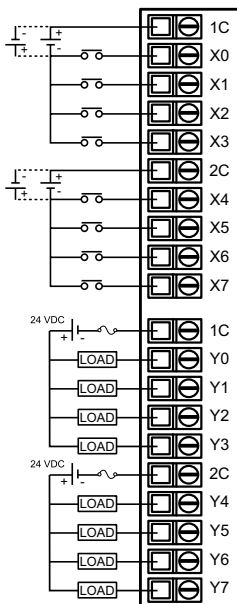

#### BX-HSIO2

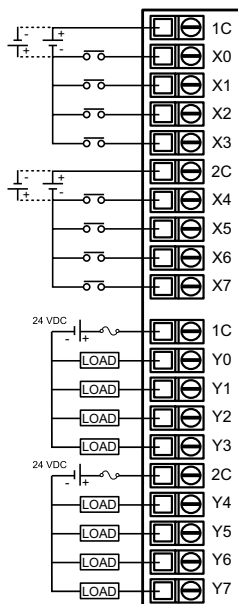

### High Speed Input/Output Specifications

Specification	BX-HSIO1	BX-HSIO2
<b>High Speed Input Specifications</b>		
Type	Sink/Source	
Total Input Points per Module	8	
Commons	2 (4 points/common) Isolated	
Nominal Voltage Range*	12–24 VDC	
Input Voltage Range*	9–30 VDC	
Maximum Voltage	30VDC	
DC Frequency	0–250 kHz	
Minimum Pulse Width	0.5 μs	
Input Impedance	3kΩ @ 24VDC	
Input Current (typical)	4mA @ 24VDC	
Maximum Input Current	8mA @ 30VDC	
ON Voltage Level	> 9.0 VDC	
OFF Voltage Level	< 2.0 VDC	
Minimum ON Current	3.0 mA (9V req'd to guarantee ON state)	
Maximum OFF Current	1.5 mA	
Status Indicators	Logic Side, Green	
OFF to ON Response	< 2μs	
ON to OFF Response	< 2μs	
<b>High Speed Output Specifications</b>		
Type	Sinking	Sourcing
Total Output Points per Module	8	
Commons	2 (4 points/common) Isolated	
Maximum Current per Common	2A	
Nominal Voltage Range*	12–24 VDC	
Operating Voltage Range*	5–36 VDC	
Maximum Voltage	36VDC	
Minimum Output Current	0.1 mA @ 24VDC	
Maximum Load Current	0.5 A per Output, No derating over temperature range	
Maximum Inrush Current	5A for 50ms	
Maximum Leakage Current	10μA	
ON Voltage Drop	0.5 VDC	
Status Indicators	Logic Side, Green	
OFF to ON Response	< 2μs	
ON to OFF Response	< 2μs	
Maximum Switching Frequency	250kHz (1m cable), 100kHz (10m cable)	
Overcurrent, Short Circuit Protection and Short to Ground	Protected by common group of 4 outputs. If tripped, Common terminal Red LED will be ON, others OFF. Self-Resetting.	
Overcurrent Trip Level	4A minimum, 8A maximum	
Fuse Type	User-supplied external fuse	
<b>General</b>		
Backplane Power Consumption	2.2 W	
Heat Dissipation	5.7 W	
Weight	85g (3oz)	
Agency Approvals	UL 61010-2-201 File #E185989 Canada and USA, CE (Immunity: EN61131-2: 2007)	
Software Version Required	Do-more! Designer v2.5 or later	

\*Class 2 or LPS Power Supply required.

# BX-HSIO1 and BX-HSIO2 High Speed I/O Modules, continued

## BX-HSIO1 High Speed Input/Output Wiring

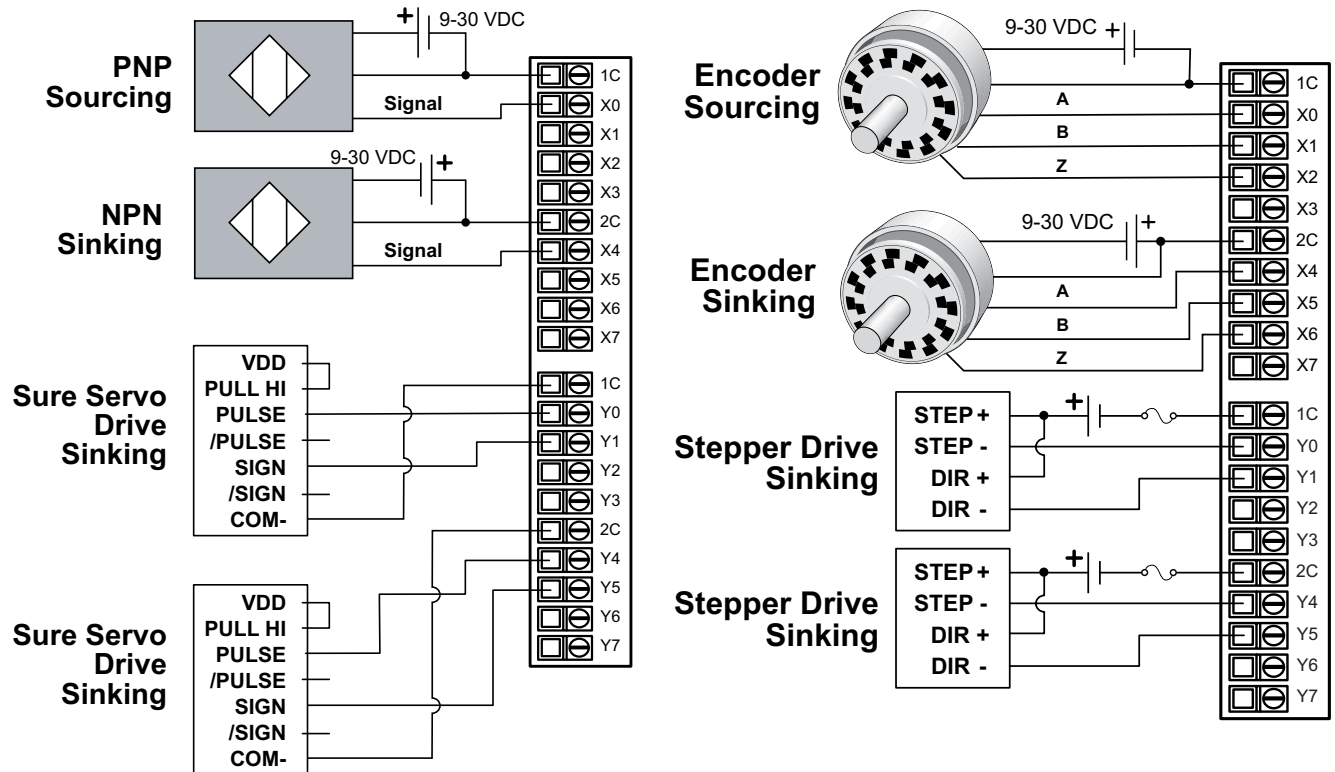

## BX-HSIO2 High Speed Input/Output Wiring

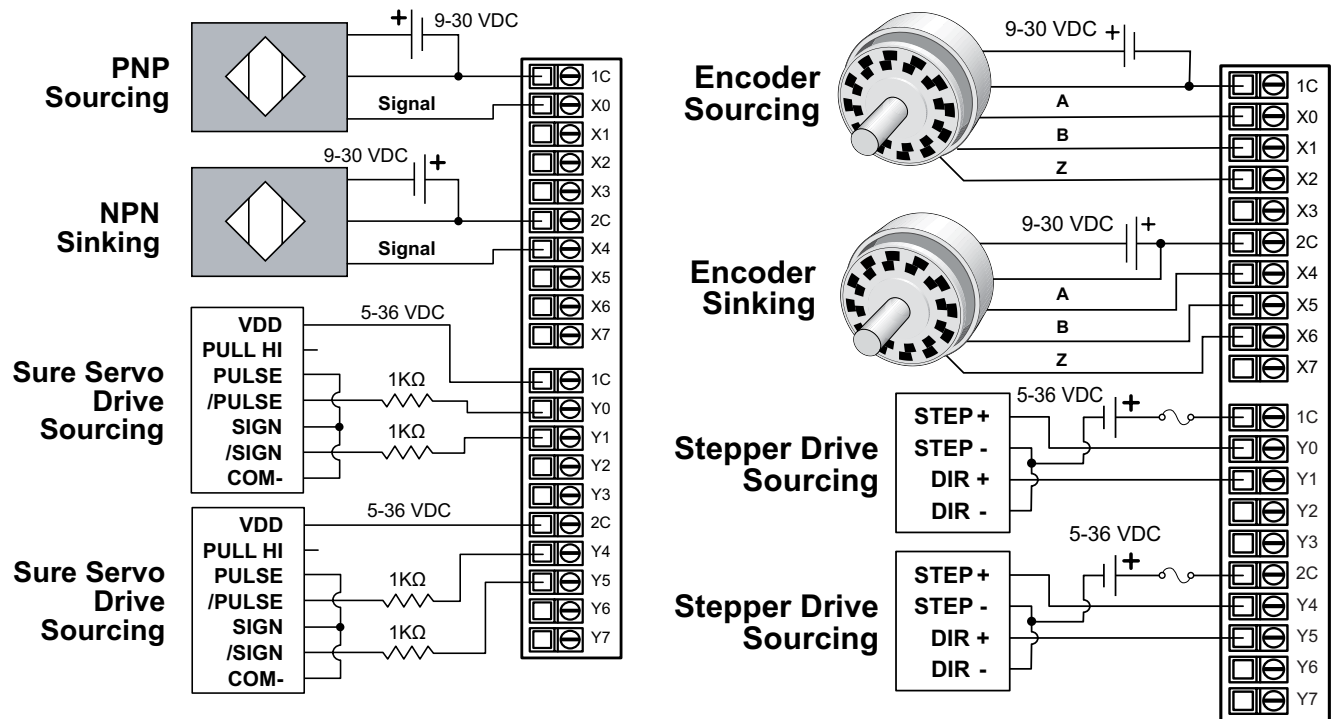

Note: VDD = 24VDC – 1KΩ resistor is needed for servo to handle this voltage. The 1KΩ resistors are not needed if a 5VDC source is used.



**NOTE:** Stepper power supplies should be separated from other components. Never place a stepper drive on the same power supply as the PLC or it's I/O.

## BX-HSIO4 High Speed Input/Output Module

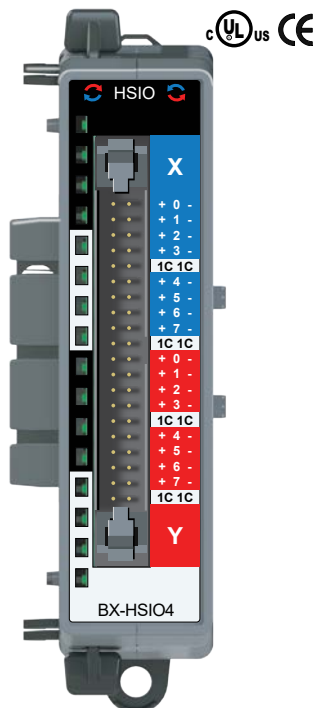

**NOTE:** This device **requires** ZIPLink Wiring Systems.



**NOTE:** Cannot be used in Remote I/O Bases.

### IMPORTANT!



#### Hot-Swapping Information

**NOTE:** This device cannot be Hot Swapped.

### High Speed Input/Output Specifications

High Speed Input Specifications	
Type	High Speed TTL Differential or Single Ended
Total Input Points per Module	8
Commons	1
Nominal Voltage Range	5VDC
Input Voltage Range	-5.5 to 5.5 VDC
Maximum Voltage	5.5 VDC
DC Frequency	0–2 MHz
Minimum Pulse Width	125ns
Input Impedance	694Ω @ 5VDC
Input Current (typical)	±7mA @ 5VDC
Maximum Input Current	10mA @ 5.5 VDC
ON Voltage Level	> +2.5 VDC differential
OFF Voltage Level	< +1.0 VDC differential
Hysteresis	50mV typical
Status Indicators	Logic Side, Green
OFF to ON Response	<125ns
ON to OFF Response	<125ns
High Speed Output Specifications	
Type	High Speed TTL Differential or Single Ended
Total Output Points per Module	8
Commons	1
Maximum Current per Common	160mA
Power Supply	Internal +5VDC
Maximum Voltage	5.5 VDC
Minimum Output Current	1μA
Maximum Load Current	20mA per Output
Maximum Leakage Current	±20μA
Differential Output Voltage	>3.0 VDC
Status Indicators	Logic Side, Green
OFF to ON Response	<125ns
ON to OFF Response	<125ns
Maximum Switching Frequency	2MHz
Overcurrent, Short Circuit Protection and Short to Ground	Protected
Overcurrent Trip Level	150mA maximum
Fuse Type	User-supplied external fuse
General	
Backplane Power Consumption	2.6 W
Heat Dissipation	3.0 W
Weight	85g (3oz)
Agency Approvals	UL 61010-2-201 File #E185989 Canada and USA, CE (Immunity: EN61131-2: 2007)
Software Version Required	Do-more! Designer v2.8 or later

# BX-HSIO4 High Speed I/O Module, continued

## BX-HSIO4 High Speed Input/Output Wiring

### ZIPLink Terminal Block Wiring Connections for BX-HSIO4

Wiring Connections for ZL-RTB40 Terminal Block																					
MODULE	LABELS																				LEVEL
BX-HSIO4	IN 0-	IN 1-	IN 2-	IN 3-	COM	IN 4-	IN 5-	IN 6-	IN 7-	COM	OUT 0-	OUT 1-	OUT 2-	OUT 3-	COM	OUT 4-	OUT 5-	OUT 6-	OUT 7-	COM	UPPER
	IN 0+	IN 1+	IN 2+	IN 3+	COM	IN 4+	IN 5+	IN 6+	IN 7+	COM	OUT 0+	OUT 1+	OUT 2+	OUT 3+	COM	OUT 4+	OUT 5+	OUT 6+	OUT 7+	COM	LOWER
TERMINAL BLOCK LABEL SHEET FOR ZIPLINK CABLE ZL-BX-CBL40-xS																					

Wiring Connections for ZL-RTB40-1 Terminal Block																	
MODULE	LABELS																LEVEL
BX-HSIO4	COM	COM	COM	COM	COM	COM	COM	COM	COM	COM	COM	COM	COM	COM	COM	COM	UPPER
	IN 0-	IN 1-	IN 2-	IN 3-	IN 4-	IN 5-	IN 6-	IN 7-	OUT 0-	OUT 1-	OUT 2-	OUT 3-	OUT 4-	OUT 5-	OUT 6-	OUT 7-	MIDDLE
	IN 0+	IN 1+	IN 2+	IN 3+	IN 4+	IN 5+	IN 6+	IN 7+	OUT 0+	OUT 1+	OUT 2+	OUT 3+	OUT 4+	OUT 5+	OUT 6+	OUT 7+	LOWER
TERMINAL BLOCK LABEL SHEET FOR ZIPLINK CABLE ZL-BX-CBL40-xS																	

### Differential 5V Encoder Input to BX-HSIO4

To prevent damage to 5V inputs, do not exceed 6.8V or 30 mA on inputs

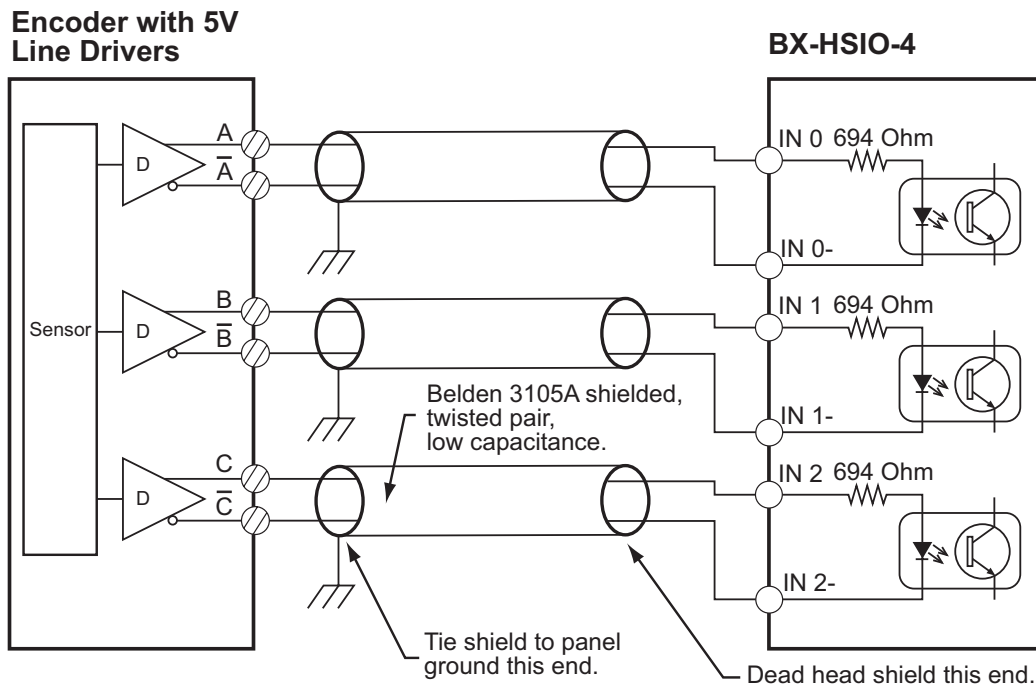

## BX-HSIO4 High Speed I/O Module, continued

### Single-Ended 5V Encoder Input to BX-HSIO4

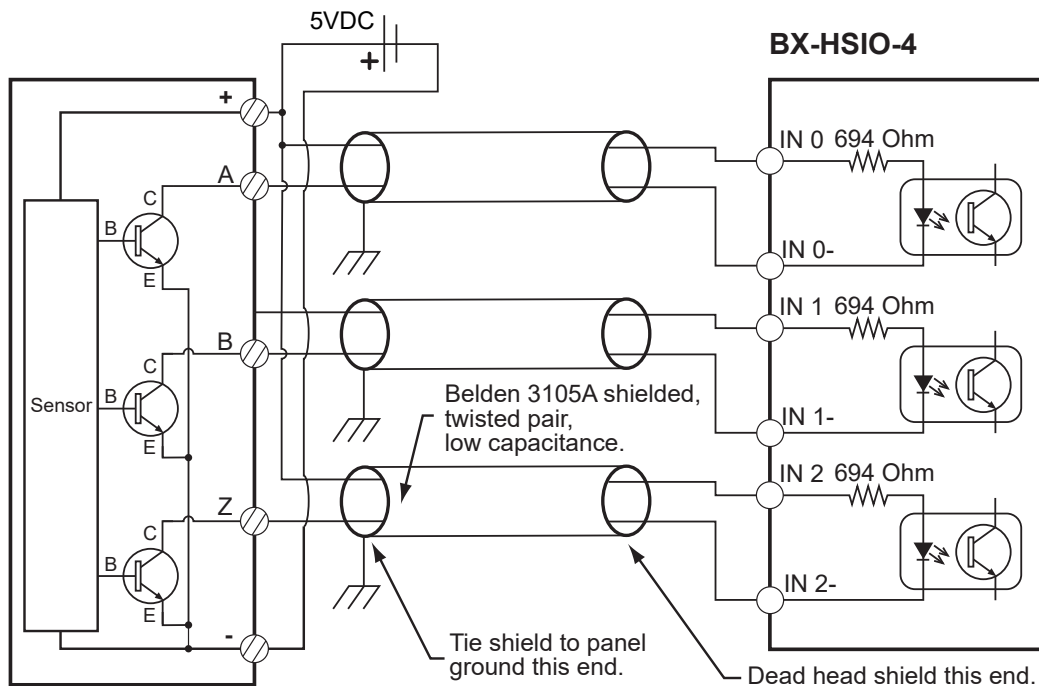

### Line Driver Pulse Output from BX-HSIO4

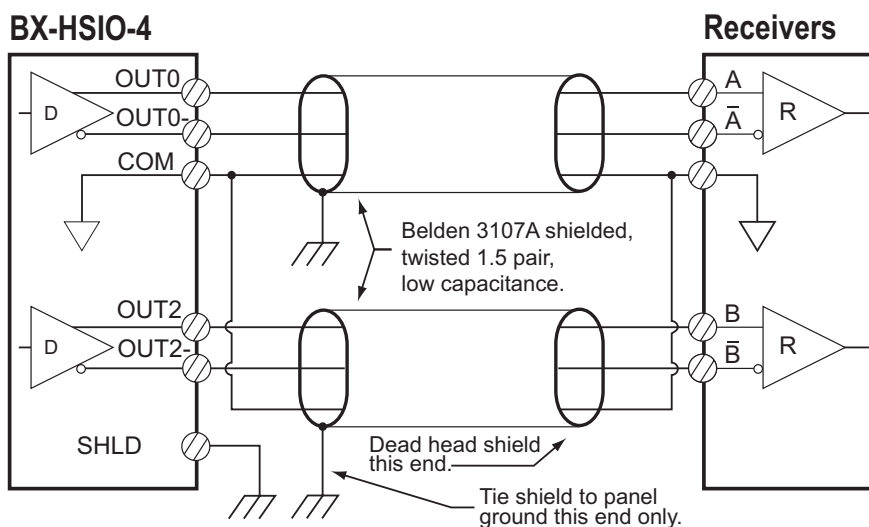

# BX-HSIO4 High Speed I/O Module, continued

## BX-HSIO-4 to SureStep

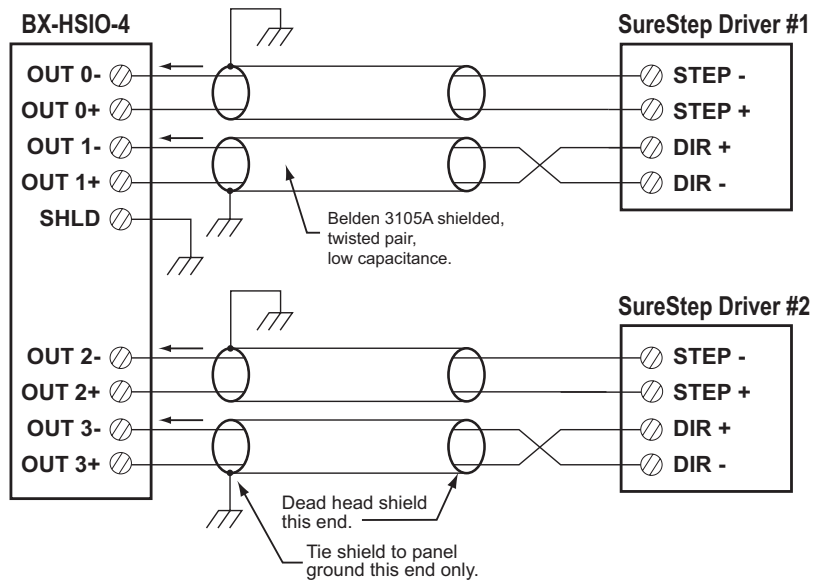

## BX-HSIO-4 to SureServo

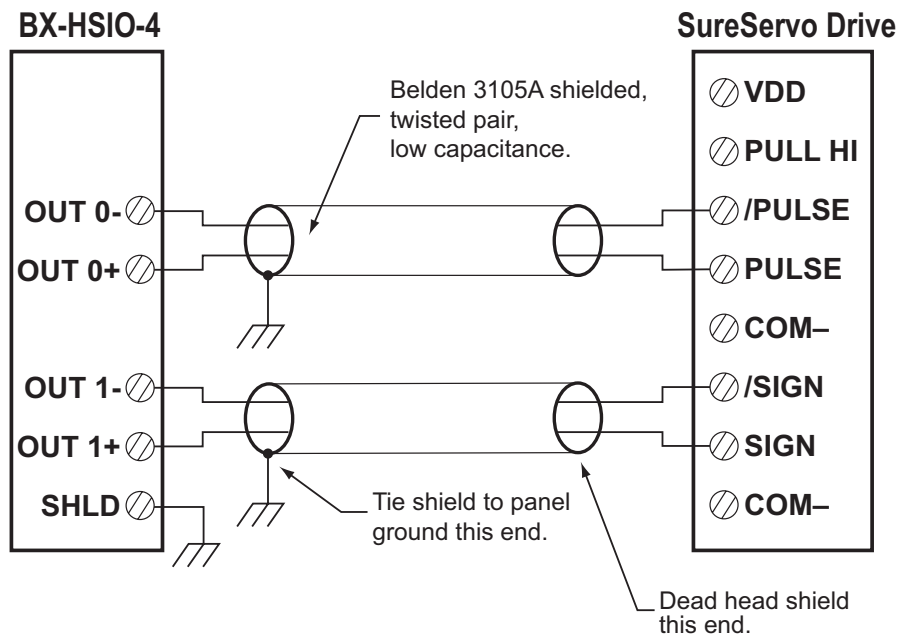

## BX-HSIO4 High Speed I/O Module, continued

### BX-HSIO-4 to Sourcing Input Device with Internal Power Supply

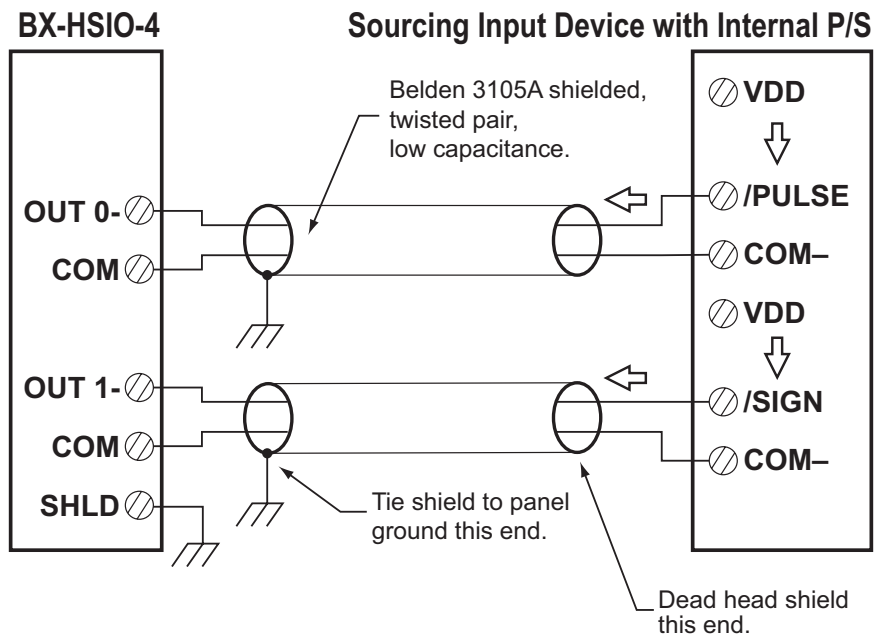

## BX-HSIOx High Speed I/O Modules Setup

The *Setup BX-HSIO Module* page for the BX-HSIOx expansion I/O modules will be displayed when the user right-clicks or left-clicks on one of the high-speed expansion modules. Input/Output and Interrupt functions are separated into the *HSIO Functions* and *Interrupt Functions* tabs, respectively.

The screenshot shows the 'Setup BX-HSIO Module' dialog box with the 'HSIO Functions' tab selected. The 'Module Configuration' section shows the name 'HSIO\_001' and info 'Module Type: BX-HSIO Assigned to: BRX Local I/O Master : BRX Local I/O : Slot 1'. The 'Input Response Times' section has a 'Filters...' button. The 'HSIO Functions' section is divided into 'Input Functions (Counter/Timer/Pulse Catch)' and 'PWM Outputs'. The 'Input Functions' section has four rows: Function 1... Disabled, Function 2... Disabled, Function 3... Disabled, and Function 4... Disabled. The 'PWM Outputs' section has four rows: PWM 1... Disabled, PWM 2... Disabled, PWM 3... Disabled, and PWM 4... Disabled. The 'Axis/Pulse Outputs' section has three rows: Axis 1... @HSIO\_001\_Axis0 - Virtual Axis, Axis 2... @HSIO\_001\_Axis1 - Virtual Axis (Outputs disabled), and Axis 3... @HSIO\_001\_Axis2 - Virtual Axis (Outputs disabled). The 'Table Driven Outputs' section has four rows: Table 1... Disabled, Table 2... Disabled, Table 3... Disabled, and Table 4... Disabled. At the bottom are 'OK', 'Cancel', and 'Help' buttons.

The screenshot shows the 'Setup BX-HSIO Module' dialog box with the 'Interrupt Functions' tab selected. The 'Module Configuration' section shows the name 'HSIO\_001' and info 'Module Type: BX-HSIO Assigned to: BRX Local I/O Master : BRX Local I/O : Slot 1'. The 'Input Response Times' section has a 'Filters...' button. The 'Interrupt Functions' section is divided into 'Input Events' and 'Timers'. The 'Input Events' section has four rows: Event 1... Disabled, Event 2... Disabled, Event 3... Disabled, and Event 4... Disabled. The 'Timers' section has four rows: Timer 1... Disabled, Timer 2... Disabled, Timer 3... Disabled, and Timer 4... Disabled. The 'Match Registers' section has four rows: Match 1... Disabled, Match 2... Disabled, Match 3... Disabled, and Match 4... Disabled. At the bottom are 'OK', 'Cancel', and 'Help' buttons.

Please see Chapter 11 in this user manual for detailed information on how to setup the I/O for use with the high-speed functions, to review various wiring examples, to review detailed programming examples and to learn more about the available high-speed instructions.

# BX-SERIO Serial Communications Module

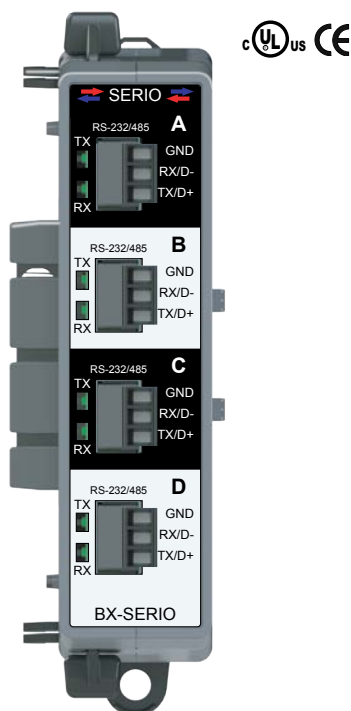

Four (4) Terminal Blocks Included  
(Part Number BX-RTB03S)

## Serial Communications Module Specifications

Number of Ports	Four RS-232/RS-485 Serial Ports	
Description	Isolated serial port that can communicate via RS-232 or RS-485 (software selectable). Includes ESD protection and built-in surge protection. Includes internal biasing to be a true failsafe receiver while maintaining EIA/TIA-485 compatibility.	
Supported Protocols	Do-more!™ Protocol (Slave)(Default), Modbus RTU (Master/Slave), K-Sequence (Slave), ASCII (In/Out), DMX512 (Master/Slave)	
Data Rates	1200, 2400, 4800, 9600, 19200, 38400, 57600, and 115200 Baud	
Default Settings	RS-232, 115200bps, No Parity, 8 Data Bits, 1 Stop Bit, Station #1, Termination resistor OFF	
Port Status LED	Green LED illuminated when active (TX and RX)	
Port Type	Removable 3-pin terminal strip 3.5 mm pitch	
	RS-232	RS-485
Station Addresses	N/A	1–247
RX/D-	Receive input (RX)	Transceiver low (D-)
TX/D+	Transmit output (TX)	Transceiver high (D+)
GND	Port Ground	
Input Impedance	5kΩ	19kΩ
Terminating Resistor	N/A	120Ω, software selectable
Maximum Load	3kΩ, 1000pf	50 transceivers, 19kΩ each, 120Ω termination
Output Short Circuit Protection	±15mA	±250mA, thermal shutdown protection
Electrostatic Discharge Protection	±1.5 kV per JESD22-C101	±7kV per IEC 61000-4-2
Electrical Fast Transient Protection	±2kV per IEC 61000-4-4	
Min. Output Voltage	±5V with 3kΩ load	Differential: 1.5 V with 60Ω load
Fail Safe Inputs	N/A	Logic high input state if inputs are unconnected
Maximum Common Mode Voltage	500 Vrms to Logic Ground	
Cable Requirements	ADC# Q8604-1	ADC# L19954-XXX
Maximum Cable Distance	30m [100ft]; 6m [20ft] rec'd max.	1000m [3280ft]
Backplane Power Consumption	1.2 W	
Heat Dissipation	1.2 W	
Weight	85g (3oz)	
Agency Approvals	UL 61010-2-201 File #E185989 Canada and USA, CE (Immunity: EN61131-2: 2007)	
Software Version	Do-more! Designer v2.5 or later	
Replacement Connector	ADC Part # BX-RTB03S	

## IMPORTANT!



### Hot-Swapping Information

**NOTE:** This device cannot be Hot Swapped.



**NOTE:** Cannot be used in Remote I/O Bases.

# BX-SERIO Serial Communications Module, continued

## Field Wiring

### Field Wiring Information

#### RS-232

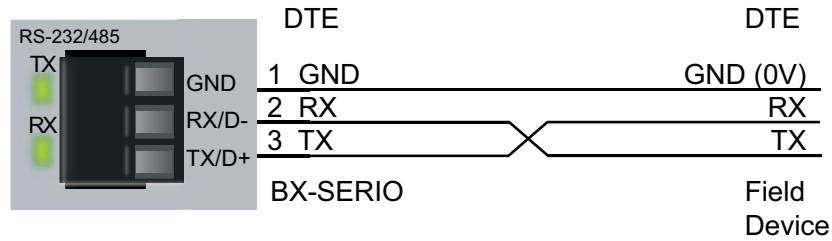

#### RS-485\*

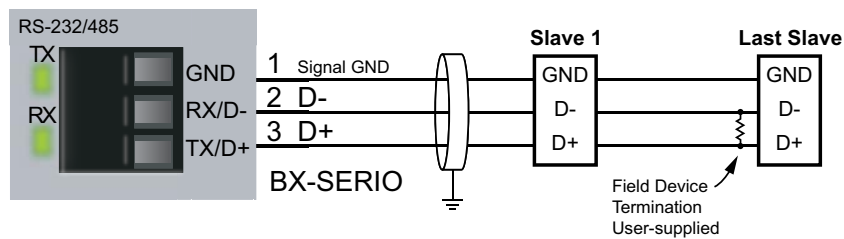

**\*NOTE:** Termination resistor is built-in and software selectable.  
 ADC # L19827-xxx or equivalent is recommended for RS-485 networks.

### Example Wiring Connections

#### C-more HMI RS-232

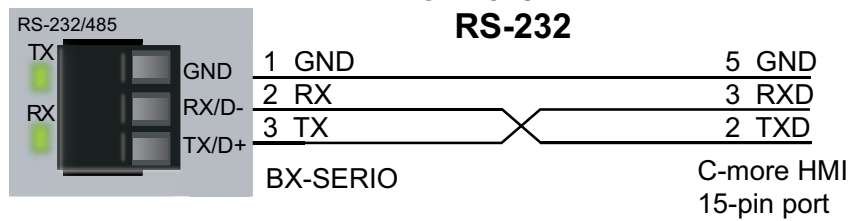

#### AutomationDirect DL06 RS-485

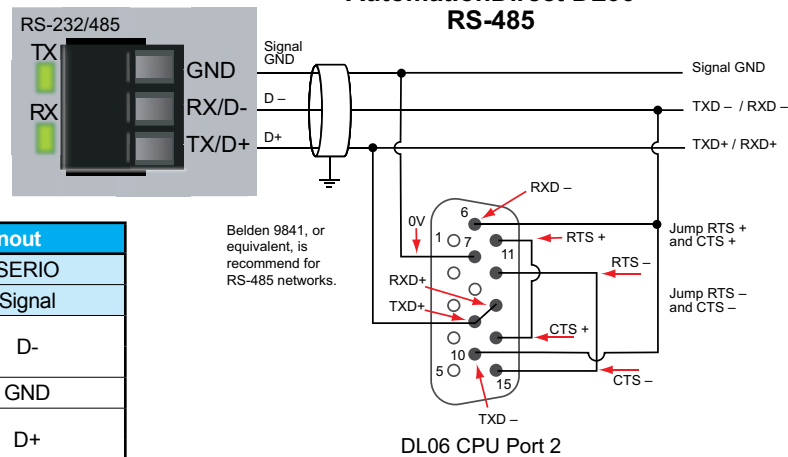

DL06 to BX-SERIO RS-485 Pinout		
DL06		SERIO
Pin	Signal	Signal
6	RXD-	D-
10	TXD-	
7	0V	GND
9	TXD+	D+
13	RXD+	
11/14	RTS+/CTS+	(jumper together)
12/15	RTS-/CTS-	(jumper together)

## BX-SERIO Serial Communications Module, continued

The *Setup BX-SERIO Module* page for the BX-SERIO expansion I/O module will be displayed when the user right-clicks or left-clicks on one of the serial communications expansion modules.

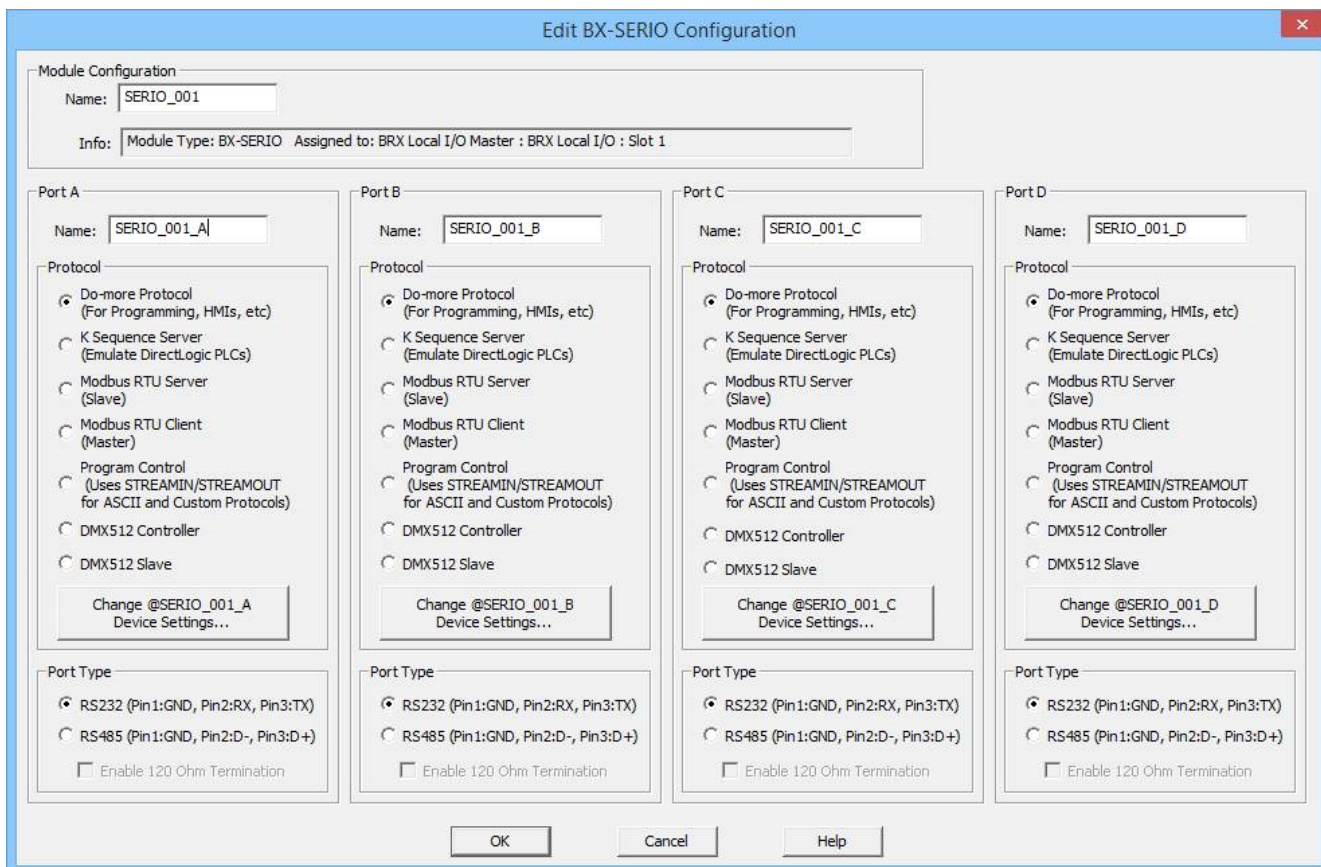

Please see Chapter 12 in this user manual for detailed information on the serial communications capabilities of the BRX platform.

# BX-SERIO-2 Serial Communications Module

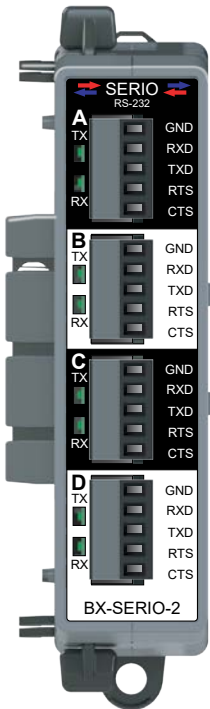

Four (4) Terminal Blocks Included  
(Part Number BX-RTB05S)

Serial Communications Module Specifications	
Number of Ports	Four RS-232 Serial Ports
Description	Isolated serial port that can communicate via RS-232. Includes ESD protection and built-in surge protection.
Supported Protocols	Do-more! Protocol (Default) Modbus RTU (Master & Slave) K-Sequence (Slave) ASCII (In & Out)
Data Rates	1200, 2400, 4800, 9600, 19200, 38400, 57600, and 115200 Baud
Default Settings	RS-232, 115200bps, No Parity, 8 Data Bits, 1 Stop Bit, Station #1
Port Status	TX and RXD)
Port Type	<i>NOTE: Cannot be configured in Remote I/O Bases.</i> RS-232
RXD	RS-232 Receive input
TXD	RS-232 Transmit output
GND	Logic Ground
CTS	RS-232 Clear to Send input
RTS	RS-232 Request to Send input
Maximum Output Load (TXD/RTS)	3kΩ, 1000pf
Minimum Output Voltage Swing	±5VDC
Output Short Circuit Protection	±15mA
Cable Requirements	ADC# L19853-XXX
Maximum Cable Distance	15m [50ft]; RS-232 has a 6m [20ft] recommended max.
Backplane Power Consumption	2.0 W
Heat Dissipation	2.0 W
Weight	85g (3oz)
Agency Approvals	UL 61010-2 File E185989, Canada and USA, CE Compliant EN61131-2
Software Version	Do-more! Designer v2.7 or later
Replacement Connector	ADC Part # BX-RTB05S

## IMPORTANT!



**Hot-Swapping Information**  
**NOTE: This device cannot be Hot Swapped.**



*NOTE: Cannot be used in Remote I/O Bases.*

## BX-SERIO-2 Serial Communications Module, continued

### Field Wiring

#### Field Wiring Information

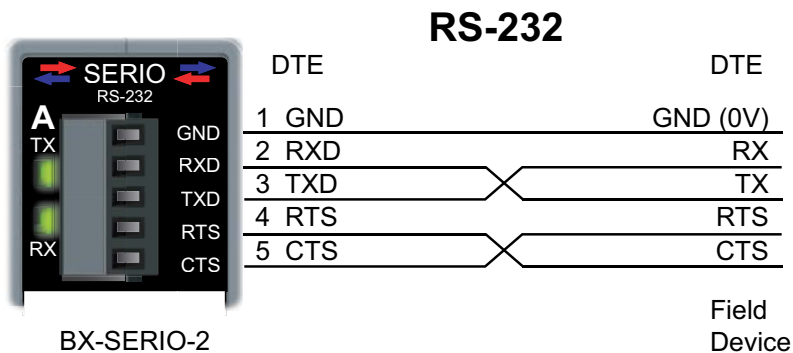

#### Example Wiring Connections

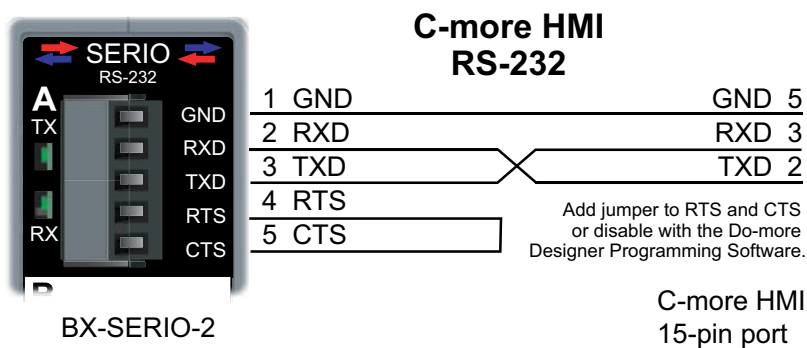

## BX-SERIO-2 Serial Communications Module Configuration, continued

The *Setup BX-SERIO Module* page for the BX-SERIO-2 expansion I/O module will be displayed when the user right-clicks or left-clicks on one of the serial communications expansion modules.

Please see Chapter 12 in this user manual for detailed information on the serial communications capabilities of the BRX platform.

# BX-SERIO-4 Serial Communications Module

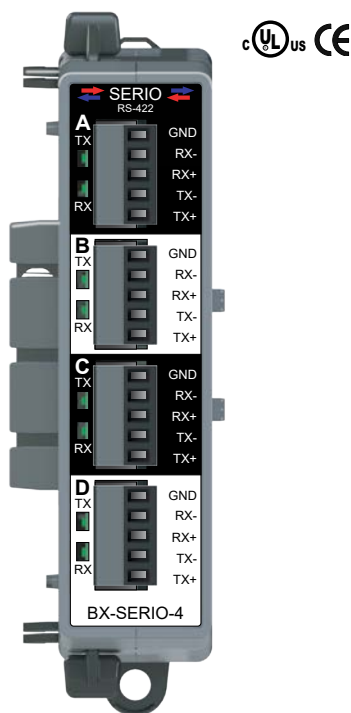

Four (4) Terminal Blocks Included  
(Part Number BX-RTB05S)

## IMPORTANT!



### Hot-Swapping Information

**NOTE:** This device cannot be Hot Swapped.

Serial Communications Module Specifications	
Number of Ports	Four RS-422 Serial Ports
Description	Isolated serial port that can communicate via RS-422. Includes ESD protection and built-in surge protection.
Supported Protocols	Do-more! Protocol (Default) Modbus RTU (Master & Slave) K-Sequence (Slave) ASCII (In & Out)
Data Rates	1200, 2400, 4800, 9600, 19200, 38400, 57600, and 115200 Baud
Default Settings	RS-422, 115200bps, No Parity, 8 Data Bits, 1 Stop Bit, Station #1
Port Status LED	Green LED illuminated when active (TX and RX)
Port Type	Removable 5-pin terminal strip 3.5 mm pitch
Station Addresses	1–247
TX-/RX-	RS-422 transceiver low
TX+/RX+	RS-422 transceiver high
GND	Logic Ground
Input Impedance	96k $\Omega$
Maximum Load	1 transceiver, 19k $\Omega$ each, 120 $\Omega$ termination
Output Short Circuit Protection	$\pm$ 250mA, thermal shutdown protection
Minimum Differential Output Voltage	2.0 VDC with 54 $\Omega$ load
Maximum Common Mode Voltage	-7.5 to 12.5 VDC
Fail Safe Inputs	Logic high input state if inputs are unconnected
Electrostatic Discharge Protection	$\pm$ 15kV per IEC61000-4-2
Cable Requirements	ADC Part# L19853-XXX
Maximum Cable Distance	1000m [3280ft]
Backplane Power Consumption	1.2 W
Heat Dissipation	1.2 W
Weight	85g (3oz)
Agency Approvals	UL 61010-2 File E185989, Canada and USA, CE Compliant EN61131-2
Software Version	Do-more! Designer v2.7 or later
Replacement Connector	ADC Part# BX-RTB05S



*NOTE:* Cannot be used in Remote I/O Bases.



*NOTE:* The BX-SERIO-4 supports point to point wiring only. Multi-Drop wiring is not supported.

# BX-SERIO-4 Serial Communications Module, continued

## Field Wiring

### Field Wiring Information

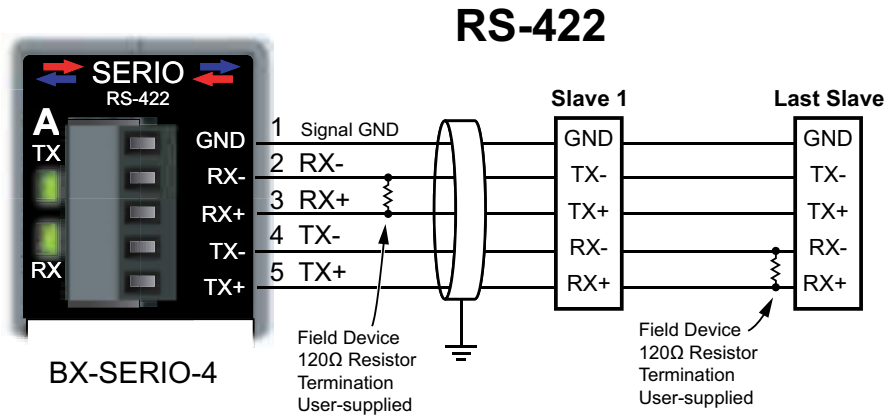

ADC # L19853-XXX or equivalent is recommend for RS-422 networks.

### Example Wiring Connections

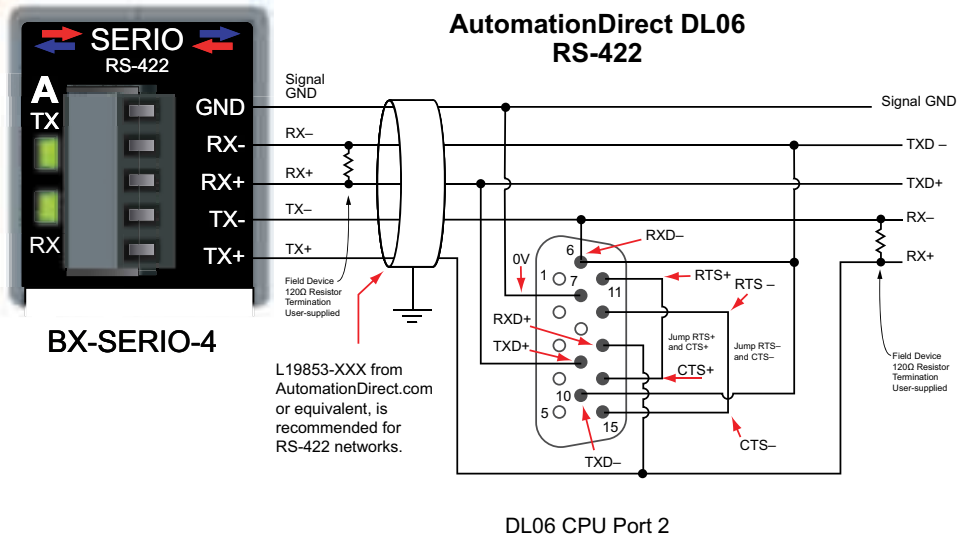

## BX-SERIO-4 Serial Communications Module Configuration, continued

The *Setup BX-SERIO Module* page for the BX-SERIO-4 expansion I/O module will be displayed when the user right-clicks or left-clicks on one of the serial communications expansion modules.

Please see Chapter 12 in this user manual for detailed information on the serial communications capabilities of the BRX platform.

## BX-APAD Active Filling Module

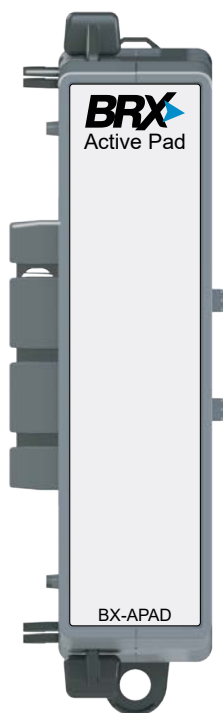

### Active Filling Module Specifications

Description	BRX active padding module, allows emulation of BRX modules in I/O configuration.
Backplane Power Consumption	0 W
Heat Dissipation	0 W
Weight	85g (3oz)
Agency Approvals	UL 61010-2 File E185989, Canada and USA, CE Compliant EN61131-2
Software Version	Do-more! Designer v2.7 or later

### IMPORTANT!



#### Hot-Swapping Information

**NOTE:** This device cannot be Hot Swapped.

## BX-APAD Active Filling Module, continued

This module emulates other BRX modules in the I/O configuration of a BRX system. It is configured in software to emulate the address space of a specific BRX module. The padding module can be used to reserve address space so that addressing in subsequent modules does not change if a module is removed. It also allows Intelligent module configurations and data structures to be emulated. The BRX processor will auto-discover the BX-APAD, like other modules as shown below.

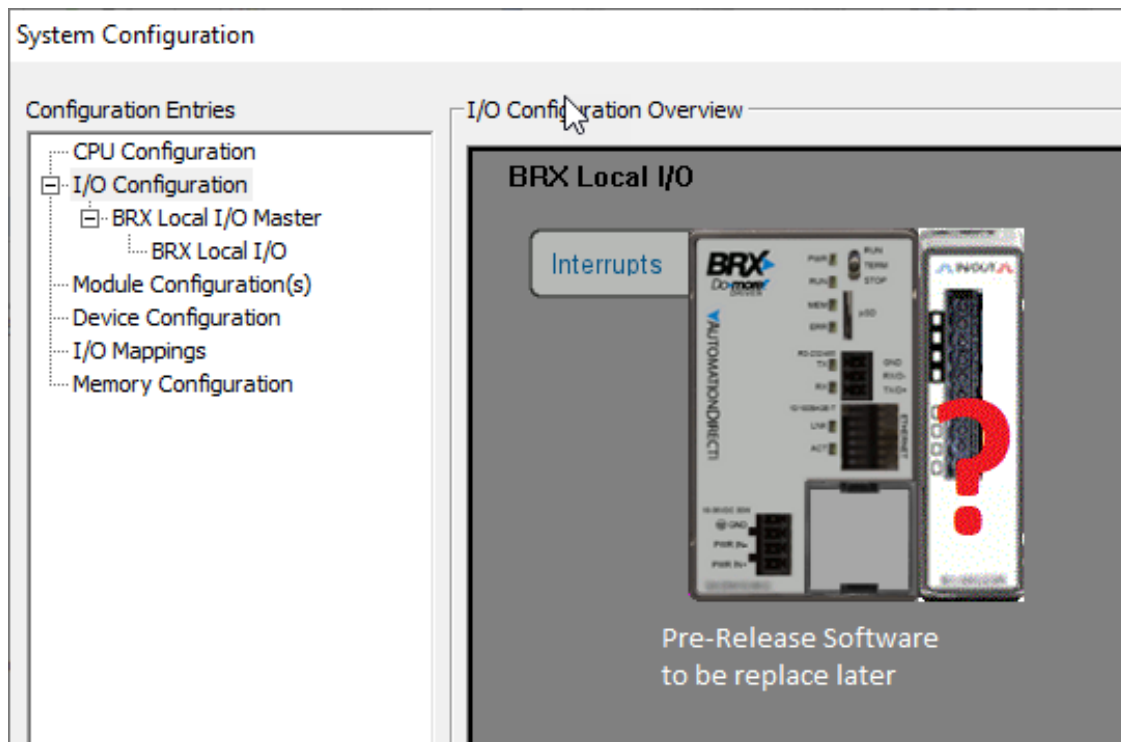

However, the user can specify which module they would like BX-APAD to emulate. To select module emulation type:

1. Select I/O Configuration>BRX Local I/O Master>BRX Local I/O.

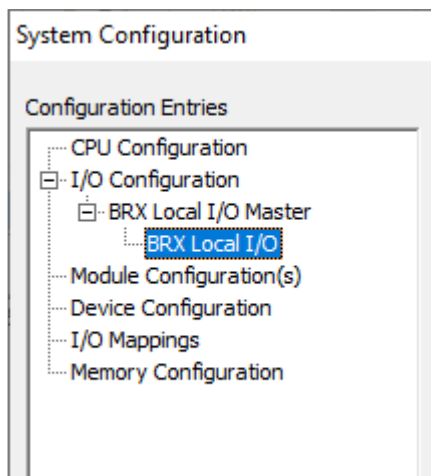

2. Right-Click on the BRX-APAD module and select “Set Module”.

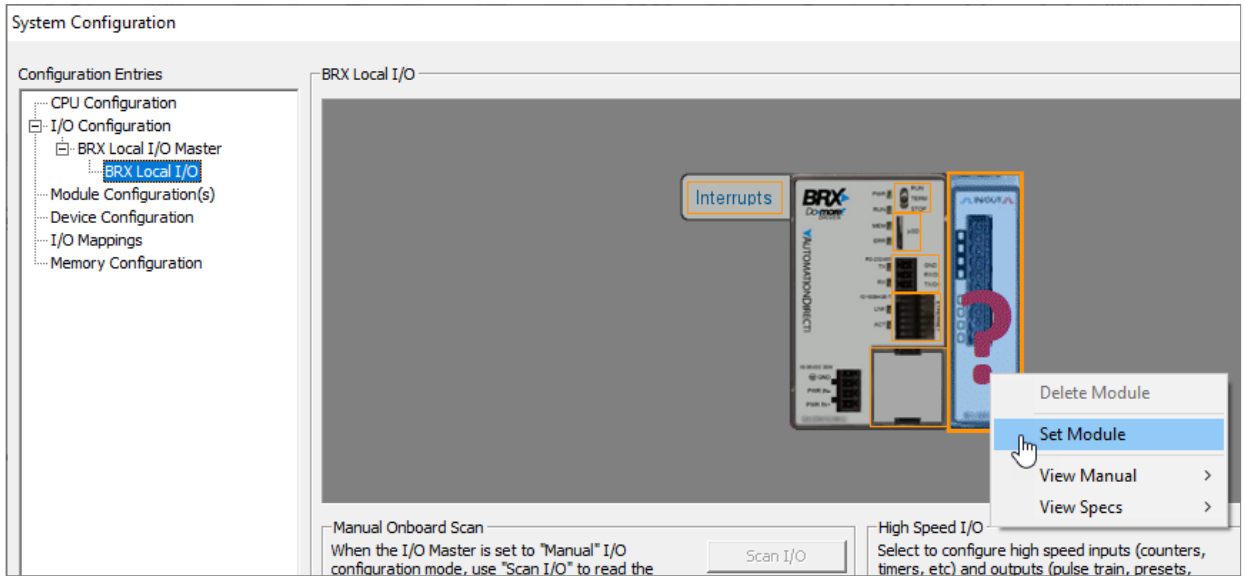

3. Select the I/O Module to emulate.

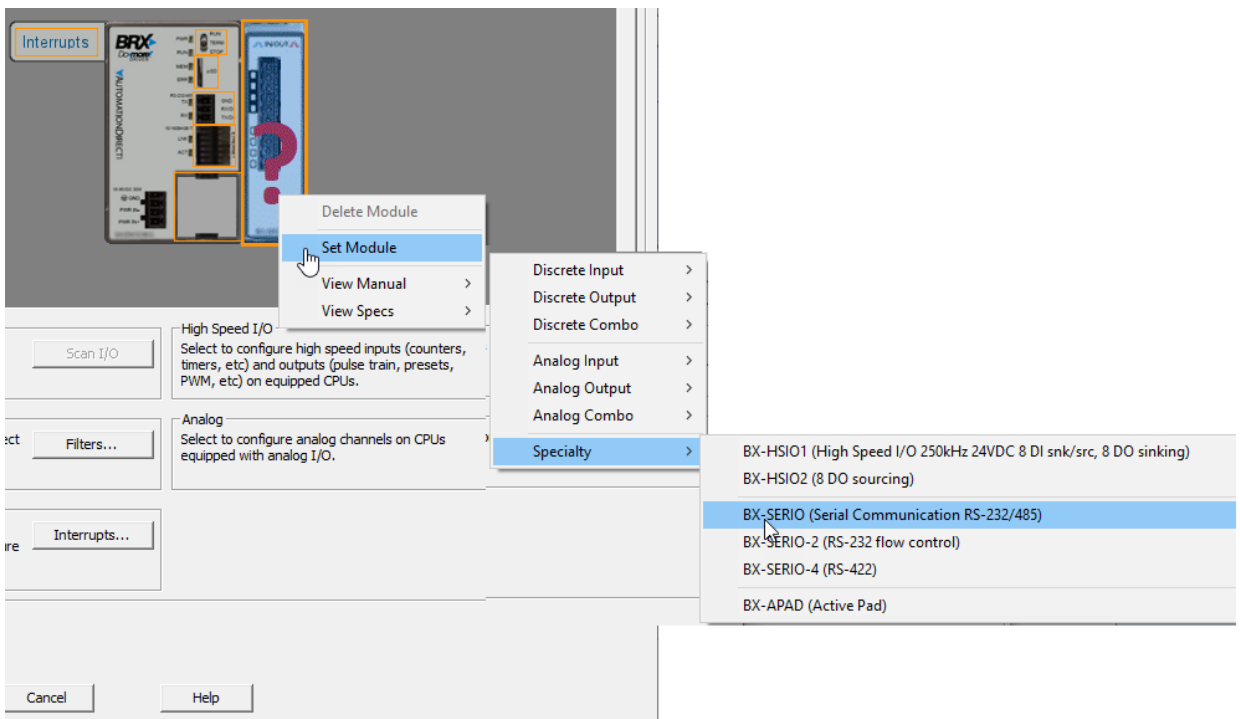

The Do-more! Designer programming software reserves physical I/O, device status attributes and configuration services.

The user can determine when the actual module is present versus the BRX-APAD by using the Get Hardware Information (HWINFO) instruction. The Get Hardware Information (HWINFO) instruction is used to retrieve hardware-specific information from an I/O module. This instruction allows a Do-more! MPU to confirm at runtime that an I/O module is present, or missing; or confirm that a module in a slot has the required I/O count, etc.



Ladder 1

In the example above, Ladder 1 is configured to read the Module ID of the I/O card installed in slot 0 of the BRX Local I/O. The instruction returns an integer value of 38668 (0x0000970C hex). This is the Module ID of the BX-APAD. A user can find all Module IDs under the Help topic: “Module ID”.

### Use Case 1

It is not uncommon for a machine builder to sell a machine in multiple configurations. In order to reduce engineering and cost, they use the same cabinet layout and PLC program. Options are added by adding additional physical inputs and output and having a software switch to enable or disable the options. For example, consider the continuous sealing machine below.



Continuous Sealing Machine



Continuous Sealing Machine with Nitrogen Flushing

The image on the left is the base model of a Continuous Sealing Machine, but the machine is also sold with a Nitrogen Flushing option as shown in the image on the right.

In a traditional rack-based PLC the machine builder may have left empty slots to accommodate the addition of additional I/O. Since BRX has a Stackable I/O configuration, adding additional I/O may require a physical change to the panel layout. The BRX-APAD will allow the machine builder to reserve the physical space in the cabinet for optional upgrades or future additions.

### Use Case 2

Similarly, a machine builder may offer a machine in a base configuration plus multiple available options. In this case, the programming can be standardized by using BX-APAD modules to reserve address space for unused options.

Since the BX-APAD reserves address space as if it were another selected module, but can be identified by the Get Hardware Information instruction, a builder can design the system so that optional programming can be automatically enabled if the appropriate module is installed, but the addressing of all other modules remains unchanged if an optional module is not present.

### Use Case 3

Another use case is when retrofitting a legacy PLC system with a BRX Control System. Most legacy PLCs had fixed rack sizes; these racks could have open slots between I/O modules. The wiring of these modules has already been established and wiring to a new PLC is either not possible or time consuming. For example, if the new and old module locations are significantly different the retrofit may require additional engineering. This is especially true if the older rack I/O had many open slots between I/O modules.

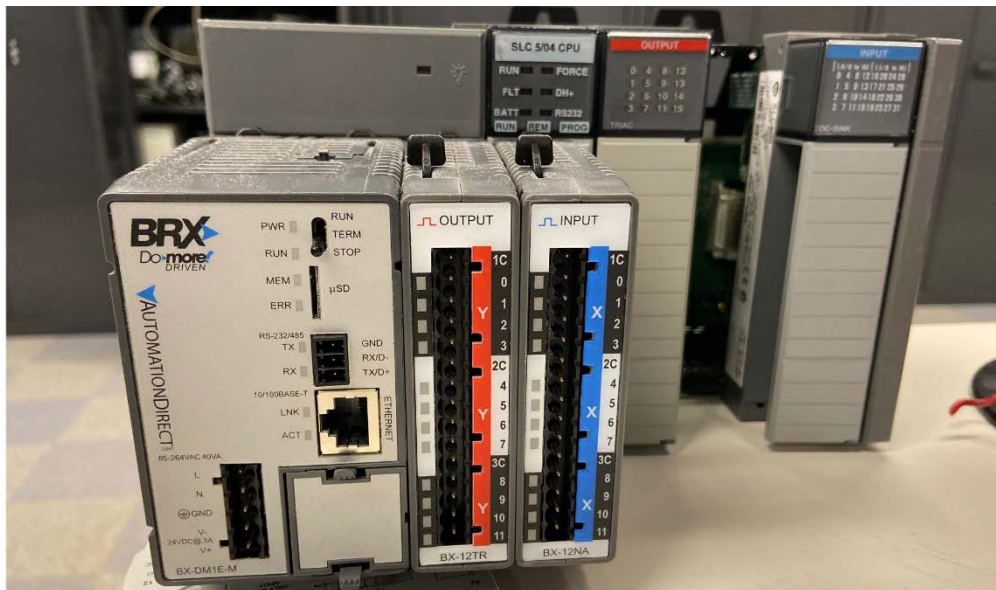

Even if the first I/O modules are aligned, it is most likely that the wires for the input modules wouldn't reach. BX-APAD can be used to emulate a empty slot in a fixed rack, which allows the module location to align. This will reduce the overall effort of the retrofit.