

BRX ANALOG I/O EXPANSION MODULES



In This Chapter...

Overview.....	8-2
Module Types.....	8-2
Wiring Termination Options.....	8-5
Terminal Block Connectors.....	8-5
ZIPLink Wiring System.....	8-7
General Specifications.....	8-8
Dimensional Information.....	8-9
Module Installation.....	8-9
Module Configuration.....	8-10
Analog Tips and Troubleshooting.....	8-11
General Tips for Analog Circuits.....	8-11
Reducing Electrical Noise.....	8-12
Current Module Tips and Troubleshooting.....	8-14
Voltage Module Tips and Troubleshooting.....	8-16
Thermocouple Module Tips and Troubleshooting.....	8-17
RTD and Thermistor Troubleshooting.....	8-17
BX-04ADM-1 Analog Current Sinking Input.....	8-18
BX-xxAD-1 Analog Current Sinking Input.....	8-23
BX-xxAD-2B Analog Voltage Input.....	8-30
BX-xxAD-3 Universal Analog Input.....	8-37
BX-xxTHM Thermocouple Input.....	8-41
BX-06RTD Resistance Temperature Detector Input.....	8-47
BX-08NTC Thermistor Input.....	8-53
BX-xxUT Universal Temperature Input.....	8-58
BX-xxDA-1 Analog Current Source Output.....	8-64
BX-xxDA-2B Analog Voltage Output.....	8-69
BX-xxDA-3 Universal Analog Output.....	8-74
BX-xADxDA-1 Combination Analog Current Input/Output.....	8-77
BX-xADxDA-2B Combination Analog Voltage Input/Output.....	8-81
BX-xADxDA-3 Universal Combination Analog Input/Output.....	8-85
BX-4RTD4DA-1 Combination RTD Input/Current Output.....	8-91
BX-4THM4DA-1 Combination Thermocouple Input/Current Output.....	8-96
BX-4UT4DA-3 Universal Temperature Input/Analog Output.....	8-101
BX-4UT4TD1 Universal Temperature Input/ DC Sinking Output.....	8-109
BX-4UT4TD2 Universal Temperature Input/ DC Sourcing Output.....	8-116
BX-4UT4TR Universal Temperature Input/ Relay Output.....	8-123

Overview

One valuable feature of the BRX platform is its ability to easily expand its capabilities to fit your application solution. One of the ways the BRX platform can do this is by using expansion modules that conveniently “snap-on” to the side of any BRX MPU.

The analog expansion modules give you the ability to add analog I/O as needed and are identified as an input module, output module, temperature input module, or combination input/output module. On the front panel of the analog I/O expansion modules, a color scheme and a symbol are used to denote the module type. Analog modules are available with current inputs/outputs, unipolar or bipolar voltage inputs/outputs, and thermocouple, resistance temperature detector (RTD) and thermistor inputs.

Module Types

Analog Input Modules

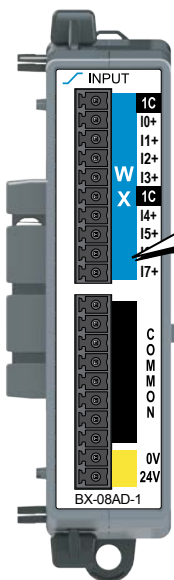

Nine (9) analog input modules are available, with current or voltage inputs, as listed below. Analog input module faceplates have a blue terminal bar to distinguish them as inputs, with symbols \swarrow or \blacktriangleleft to signify current or voltage, respectively.

Analog Input Modules

Identifier	Input Type	Resolution	4-Point	8-Point	16-Point
ADM-1	Current Sink 0–20mA, 4–20mA	14-bit	BX-04ADM-1	-	-
AD-1	Current Sink 0–20mA, 4–20mA	16-bit	BX-04AD-1	BX-08AD-1	BX-16AD-1
AD-2B	Voltage $\pm 10\text{VDC}$, $\pm 5\text{VDC}$, 0–5VDC, 0–10VDC	16-bit	BX-04AD-2B	BX-08AD-2B	BX-16AD-2B
AD-3	Current Sink 0–20mA, 4–20mA Voltage $\pm 10\text{VDC}$, $\pm 5\text{VDC}$, 0–5VDC, 0–10VDC	16-bit	BX-04AD-3	BX-08AD-3	-

Temperature Input Module

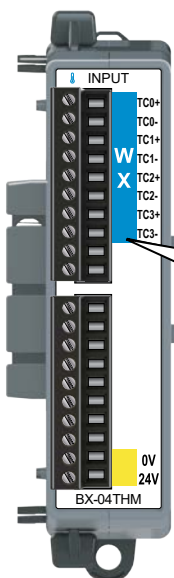

Six (6) temperature input modules are available, with thermocouple, RTD, and/or thermistor inputs, as listed below. The thermocouple input modules can also be configured for millivolt-level voltage inputs, and the RTD input module can also be configured for resistance input. Temperature module faceplates have a blue terminal bar to distinguish them as inputs, with symbol \downarrow to signify temperature.

Temperature Input Modules

Identifier	Input Type	4-Point	6-Point	8-Point
THM	Thermocouple	BX-04THM	-	BX-08THM
RTD	Resistance Temperature Detector (RTD)	-	BX-06RTD	-
NTC	Thermistor	-	-	BX-08NTC
UT	Universal Temperature (Thermocouple, RTD, Thermistor)	BX-04UT	BX-08UT	-



NOTE: Temperature Input Modules do not support **ZIPLink** Wiring Systems.

Temperature Input/Analog Output Combination Modules

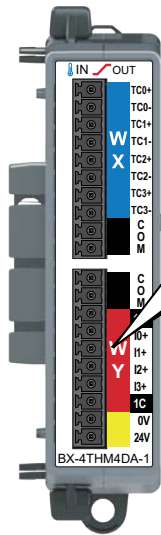

Three (3) combination modules are available with thermocouple, RTD or universal temperature inputs and current sourcing or current/voltage outputs, as listed below. The thermocouple input modules can also be configured for millivolt-level voltage inputs, and the RTD input module can also be configured for resistance input. The Input/Output faceplate terminal bar is in blue and red, making it easy to distinguish between inputs and outputs, and the , and signify temperature, current and universal analog, respectively.

Temperature Input/Analog Output Combination Modules

Identifier	Input Type	Output Type	# Inputs	# Outputs	Part #
xRTDxDA-1	Resistance Temperature Detector (RTD)	Current Source 0–20mA, 4–20mA	4	4	BX-4RTD4DA-1
xTHMxDA-1	Thermocouple	Current Source 0–20mA, 4–20mA	4	4	BX-4THM4DA-1
xUTxDA-3	Universal Temperature (Thermocouple, RTD, Thermistor)	Current Source 0–20mA, 4–20mA Voltage ±10VDC, ±5VDC, 0–5VDC, 0–10VDC	4	4	BX-4UT4DA-3



NOTE: Combination Modules with temperature inputs do not support **ZIPLink** Wiring Systems.

Temperature Input/Discrete Output Combination Modules

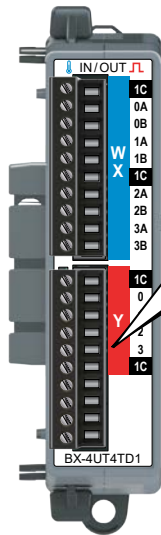

Three (3) combination modules are available with universal temperature inputs and DC sinking, sourcing or relay outputs, as listed below. The Input/Output faceplate terminal bar is in blue and red, making it easy to distinguish between inputs and outputs, and the and signify temperature and discrete signals, respectively.

Temperature Input/Discrete Output Combination Modules

Identifier	Input Type	Output Type	# Inputs	# Outputs	Part #
xUTxTD1	Universal Temperature (Thermocouple, RTD, Thermistor)	12–24 VDC Sinking	4	4	BX-4UT4TD1
xUTxTD2		12–24 VDC Sourcing	4	4	BX-4UT4TD2
xUTxTR		Relay Form A (SPST)	4	4	BX-4UT4TR



NOTE: Combination Modules with temperature inputs do not support **ZIPLink** Wiring Systems.

Analog Output Modules

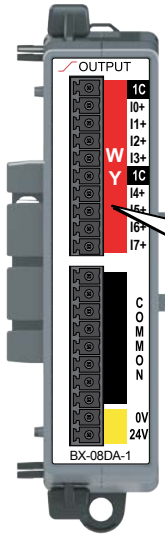

Six (6) analog output modules are available, in current and voltage outputs, as listed below. Analog output module faceplates have a red terminal bar to distinguish them as outputs, with symbols \swarrow , \blacktriangle or $_$ to signify current, voltage or universal analog signals, respectively.

Analog Output Modules			
Identifier	Type	4-Point	8-Point
DA-1	Current Source 0–20mA, 4–20mA	BX-04DA-1	BX-08DA-1
DA-2B	Voltage ± 10 VDC, ± 5 VDC, 0–5VDC, 0–10VDC	BX-04DA-2B	BX-08DA-2B
DA-3	Current Source 0–20mA, 4–20mA Voltage ± 10 VDC, ± 5 VDC, 0–5VDC, 0–10VDC	BX-04DA-3	BX-08DA-3

Analog Combo Input/Output Modules

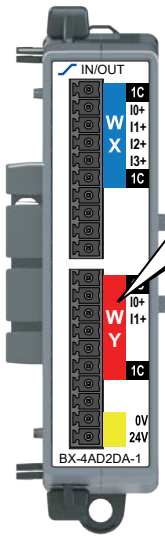

Six (6) analog input/output combo modules are available, with current or voltage inputs and outputs, as listed below. Analog combo module faceplates have red and blue terminal bars to distinguish the input and output sections, respectively. Symbols \swarrow and \blacktriangle signify current and voltage, respectively, and are colored blue for inputs and red for outputs.

Analog Combination Input/Output Modules					
Identifier	Input Type	Output Type	# Inputs	# Outputs	Part #
xADxDA-1	Current Sink 0–20mA, 4–20mA	Current Source 0–20mA, 4–20mA	2	2	BX-2AD2DA-1
			4	2	BX-4AD2DA-1
xADxDA-2B	Voltage ± 10 VDC, ± 5 VDC, 0–5VDC, 0–10VDC	Voltage ± 10 VDC, ± 5 VDC, 0–5VDC, 0–10VDC	2	2	BX-2AD2DA-2B
			4	2	BX-4AD2DA-2B
xADxDA-3	Current Source 0–20mA, 4–20mA Voltage ± 10 VDC, ± 5 VDC, 0–5VDC, 0–10VDC	Current Source 0–20mA, 4–20mA Voltage ± 10 VDC, ± 5 VDC, 0–5VDC, 0–10VDC	2	2	BX-2AD2DA-3
			4	4	BX-4AD4DA-3

Wiring Termination Options

The BRX analog expansion modules ship without wiring terminal blocks. This enables you to select the termination style that best fits your application. Several wiring options are available, including removable screw terminal connectors, removable spring clamp terminal connectors and pre-wired **ZIPLink** cable solutions. The BRX temperature input modules include the BX-RTB10 kit. The BX-RTB10-1 or BX-RTB10-2 can also be used and can be purchased separately.

Terminal Block Connectors

The terminal block connectors are provided in kits of multiple connectors that are easily ordered as a single part number. BX-RTB10 kits include (2) 10-pin 3.81-mm connectors. The 5-wire terminal blocks are available as single units (BX-RTB05) or as kits of three connectors (BX-RTB08).

Terminal block kit part numbers and connector specifications are listed in the table below.

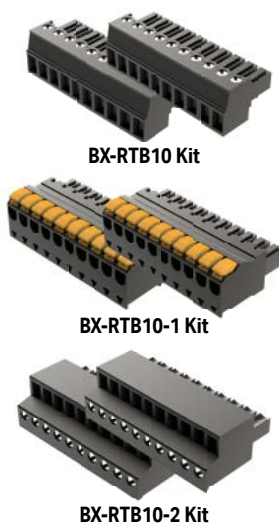

10-Wire Terminal Block Specifications

Part Number	BX-RTB10	BX-RTB10-1	BX-RTB10-2
Connector Type	Screw Type 90°	Spring Clamp Type 180°	Screw Type 180°
Wire Exit	180°	180°	180°
Pitch	3.81 mm	3.81 mm	3.81 mm
Screw Size	M2	N/A	M2
Screw Torque Recommended	<1.77 lb·in (0.2 N·m)	N/A	<1.77 lb·in (0.2 N·m)
Screwdriver Blade Width	2.5 mm	2.5 mm	2.5 mm
Wire Gauge (Single Wire)	28–16 AWG	26–18 AWG	30–16 AWG
Wire Gauge (Dual Wire)	28–18 AWG	30–20 AWG (Dual Wire Ferrule Required)	30–18 AWG
Wire Strip Length	0.24 in (6mm)	0.35 in (9mm)	0.26 in (6.5 mm)
Equiv. Dinkle P/N	EC381V-10P-BK	ESC381V-10-BK	EC381F-10P-BK



NOTE: BX-RTB10 terminal blocks are included with Temperature Input modules.



5-Wire Terminal Block Specifications

Part Number Single Block Set of 3 Blocks	BX-RTB05 BX-RTB08	BX-RTB05-1 BX-RTB08-1	BX-RTB05-2 BX-RTB08-2
Connector Type	Screw Type 90°	Spring Clamp Type 180°	Screw Type 180°
Wire Exit	180°	180°	180°
Pitch	5.0 mm	5.0 mm	5.0 mm
Screw Size	M2.5	N/A	M2.5
Screw Torque Recommended	<3.98 lb·in (0.45 N·m)	N/A	<3.98 lb·in (0.45 N·m)
Screwdriver Blade Width	3.5 mm	3.5 mm	3.5 mm
Wire Gauge (Single Wire)	28–12 AWG	26–14 AWG	28–12 AWG
Wire Gauge (Dual Wire)	28–16 AWG	28–16 AWG (Dual Wire Ferrule Required)	28–16 AWG
Wire Strip Length	0.3 in (7.5 mm)	0.37 in (9.5 mm)	0.3 in (7.5 mm)
Equiv. Dinkle P/N	5ESDV-05P-BK	5ESDSR-05P-BK	5ESDF-05P-BK

Wiring Termination Options, continued



BX-RTB03



BX-RTB03-1



BX-RTB03-2

3-Wire Terminal Block Specifications

Part Number	BX-RTB03	BX-RTB03-1	BX-RTB03-2
Connector Type	Screw Type 90°	Spring Clamp Type 180°	Screw Type 180°
Wire Exit	180°	180°	180°
Pitch	5.0 mm	5.0 mm	5.0 mm
Screw Size	M2.5	N/A	M2.5
Screw Torque Recommended	<3.98 lb·in (0.45 N·m)	N/A	<3.98 lb·in (0.45 N·m)
Screwdriver Blade Width	3.5 mm	3.5 mm	3.5 mm
Wire Gauge (Single Wire)	28–12 AWG	26–14 AWG	28–12 AWG
Wire Gauge (Dual Wire)	28–16 AWG	28–16 AWG (Dual Wire Ferrule Required)	28–16 AWG
Wire Strip Length	0.3 in (7.5 mm)	0.37 in (9.5 mm)	0.3 in (7.5 mm)
Equiv. Dinkle P/N	5ESDV-03P-BK	5ESDSR-03P-BK	5ESDF-03P

ZIPLink Wiring System

BRX analog expansion modules can be quickly connected to convenient **ZIPLink** remote terminal blocks for ease of wiring remote I/O devices. The table below lists the connector options. The **ZIPLink** wiring system is not available for use with BRX modules with temperature input.

BRX Analog Expansion Module ZIPLink Selector					
Expansion Module Part No.	ZIPLink Module	ZIPLink Module Part No.	Qty Needed	ZIPLink Cable Part No.*	Qty Needed
BX-04ADM-1	Feedthrough	ZL-RTB20 (standard) OR ZL-RTB20-1 (compact)	1	ZL-BXEM-CBL20 ZL-BXEM-CBL20-1 ZL-BXEM-CBL20-2	1
BX-04AD-1					
BX-04AD-2B					
BX-08AD-1					
BX-08AD-2B					
BX-16AD-1					
BX-16AD-2B					
BX-04DA-1					
BX-04DA-2B					
BX-08DA-1					
BX-08DA-2B					
BX-2AD2DA-1					
BX-4AD2DA-1					
BX-2AD2DA-2B					
BX-4AD2DA-2B					
BX-08AD-3					
BX-08DA-3					
BX-4AD4DA-3					
BX-4AD4DA-3					
BX-04THM				Temperature Input modules are not supported by the ZIPLink wiring system.	
BX-08THM					
BX-06RTD					
BX-08NTC					
BX-04UT					
BX-08UT					
BX-4THM4DA-1					
BX-4RTD4DA-1					
BX-4UT4DA-3					
BX-4UT4TD1					
BX-4UT4TD2					
BX-4UT4TR					

* Select the cable length: Blank = 0.5 m, -1 = 1.0 m, -2 = 2.0 m.

Available pigtail cables: ZL-BXEM-CBLxx-1P = 1.0 m, ZL-BXEM-CBLxx-2P = 2.0 m.



General Specifications

All BRX analog expansion modules and temperature input modules have the same general specifications listed in the tables below.

General Specifications	
Storage Temperature	-20° to 70°C (-4° to 158°F)
Humidity	5 to 95% (non-condensing)
Environmental Air	No corrosive gases permitted
Vibration	IEC60068-2-6 (Test Fc)
Shock	IEC60068-2-27 (Test Ea)
Enclosure Type	Open Equipment
Noise Immunity	NEMA ICS3-304
EU Directive	See the "EU Directive" topic in the BRX Help File.

Operating Temperature Range		
Operating Temperature	0° to 45°C (32° to 113°F)	0° to 60°C (32° to 140°F)
Module	Module Revision*	
BX-08AD-1	Rev A (Prior to May 2018)	Rev B (After May 2018)
BX-08AD-2B		
BX-04THM		
BX-08DA-1		
BX-08DA-2B	Rev B (Prior to May 2018)	Rev C (After May 2018)
All other Analog and Temperature Expansion Module part numbers	N/A	Rev A (After May 2018)

* Module Revision can be found in the last letter (last or second-to-last character) of the module serial number.

Dimensional Information

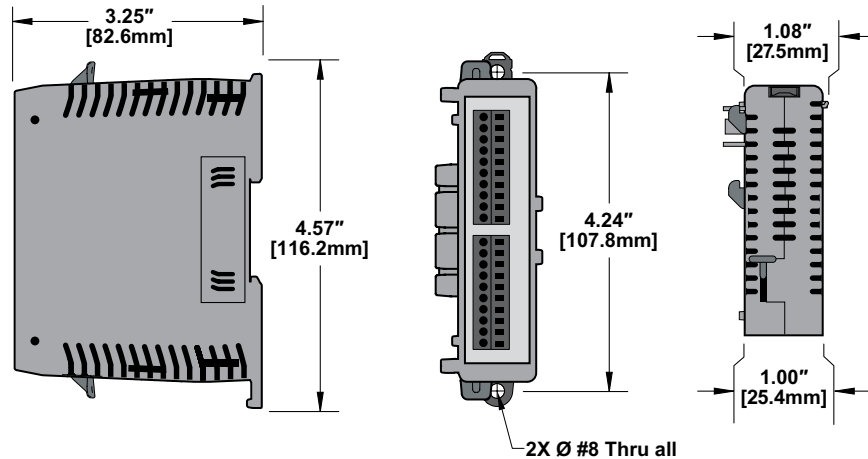

Module Installation



WARNING: Do not apply field power until the following steps are completed. The BRX expansion modules are **NOT** hot swappable.

To install an expansion module, remove the connector cover on the right side of the MPU or expansion module to which the new module is to be connected. Align the expansion connectors and insert the module until you hear a “click,” indicating the module expansion connectors have engaged.

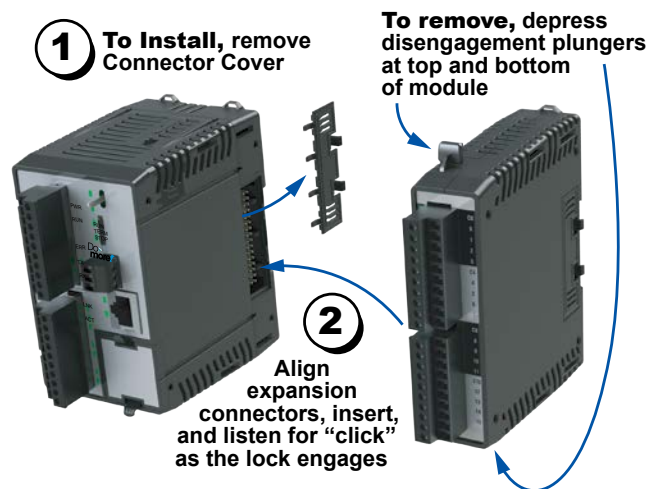

To remove an expansion module, locate the two disengagement plungers. One is located at the top of the of the expansion module and a second one at the bottom of the expansion module. Depressing both plungers at the same time will release the locking mechanism and disengage the unit from the system.



NOTE: Allow a minimum of 45mm (1.75 in) to the right of the MPU chassis or any subsequent expansion modules for mounting and dismounting of the modules.

Module Configuration

Once the expansion module has snapped in place and is added to the project, it instantly adds additional I/O and features to the MPU with minimal additional setup required.

To configure a newly attached module, load the Do-more! Designer software and connect to the BRX MPU, as discussed in the Do-more! Designer Software Getting Started Guide (DMD-GSG-M) which can be found at <http://support.automationdirect.com/products/domore.html>. A graphical representation of the BRX unit with its attached modules is displayed in the Dashboard of the software.

The screenshot displays the Do-more! Designer software dashboard. At the top, there are four status panels: Program, Documentation, Communications, and I/O. Below these is a central graphic of the BRX unit with a context menu open over one of the modules. The menu options are: Delete Module, Configure Module (highlighted with a red circle and the number 1), View Manual, and View Specs. Below the central graphic are three more status panels: CPU, Memory, and Devices.

Program	Documentation	Communications	I/O
View/Edit the Program Code-blocks: 1 Matches PLC, different than disk Do-more Technology Version: 2.0 Program memory used: <1%	Add/Edit Element Documentation Matches PLC, different than disk Documentation memory used: <1%	Modbus/TCP Server: ENABLED Ethernet/IP Server: DISABLED	Ethernet I/O Master: DISABLED I/O Slaves: 0 I/O System Status: GOOD Interrupts Enabled: 1

CPU	Memory	Devices
Connected to 10.1.1.125 BX-DM1E-18ED13 (00 E0 62 30 06 61) PLC is in PROGRAM mode IP Address: 10.1.1.125 OS: 2.0.4 Log Entries: 0 User/85 System Scan Time: 196µs	Change memory configuration Open Cross-Reference View Different than PLC and disk Memory image: 0 regions No forces active Memory allocated: 40%	Add/edit devices 16 devices present Device status: OK

To access the module configuration dialogs, left-click or right-click on the module in the Dashboard and select (1) **Configure Module**. The configuration dialogs for each module are discussed in the corresponding section of this chapter.

Analog Tips and Troubleshooting

This subsection presents common tips on selection and installation of analog hardware, as well as basic troubleshooting techniques, to maximize the performance of your analog input/output circuits.

General Tips for Analog Circuits

When selecting and installing analog devices a few things should be considered:

- Current devices are much more tolerant of noise than voltage devices.
- Current devices can handle much longer runs of wire without signal loss.
- Shielded twisted pair wire should always be used. Analog signals are typically low power, and the better your isolation the less noise you will have degrading the signal.
- If the analog signal is from a thermocouple, the appropriate thermocouple extension wire and terminal blocks must be used if needed to extend wire lengths.
- Use the shortest wiring route whenever possible.
- Do not run analog signal wiring in the same conduit or wire way as AC wiring.
- Do not run analog signal wiring next to large motors, high current switches, or transformers.
- Route the wiring through an approved cable housing to minimize the risk of accidental damage.
- Shields should be connected only at one end, to ground at the source device. Connecting both ends of a shield will create a ground loop, which can increase the noise in a circuit.
- Bonding of the DC negative to ground should be considered, with the exception of Class II power supplies which should never be bonded to ground. This can help with reducing noise induced into analog circuits. Please note that consideration should be given to all devices that will utilize the power supply to ensure that bonding of the negative will not cause damage or interference.
- AC power should be checked from neutral to ground. This voltage should be less than 0.1 VAC.



NOTE: Your company may have guidelines for wiring and cable installation. If so, you should check those before you begin the installation.



NOTE: Check local and national codes to choose the correct method for your application.

Reducing Electrical Noise

Electrical noise is one of the most difficult problems to diagnose. It can enter the system from a wide range of conducted or radiated sources.

Conducted noise is when the electrical interference is introduced into the system by way of an attached wire, panel connection, etc. It may enter through an I/O point, a power supply connection, the communication ground connection, or the chassis ground connection.

Radiated noise is when electrical interference is introduced into the system without a direct electrical connection, such as via radio waves.

It may be difficult to determine how electrical noise is entering the system, but the corrective actions for either type of noise problem are similar.

While electrical noise cannot be eliminated completely, it can be reduced to a level that will not affect system function. Proper grounding of components and signal wiring along with proper isolation of voltages can minimize noise in the system.

Grounding

Most noise problems result from improper grounding of the system. A good earth ground can be the single most effective way to correct noise problems. If a ground is not available, install a ground rod as close to the system as possible.

Ensure all ground wires are single point grounds and are not daisy chained from one device to another. Ground metal enclosures around the system. Loose ground wires on your devices are more susceptible to noise than the other wires in your system. A loose wire is no more than a large antenna waiting to introduce noise into the system; therefore, you should tighten all connections in your system. Review Chapter 1, “General Installation and Wiring Guidelines,” if you have questions regarding how to ground your system.

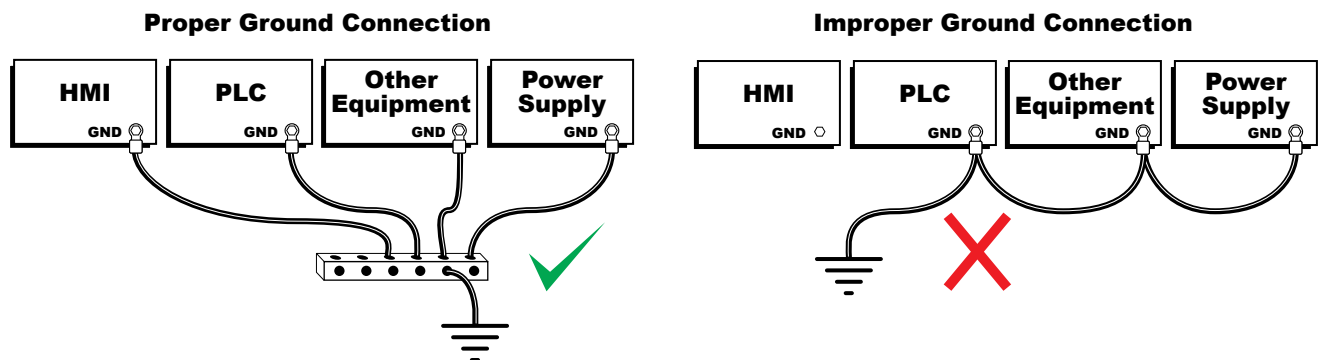

Cables with shields should be grounded on only one end of the shield. This prevents ground loops and allows for any radiated noise collected by the shield to properly drain to a single ground point.

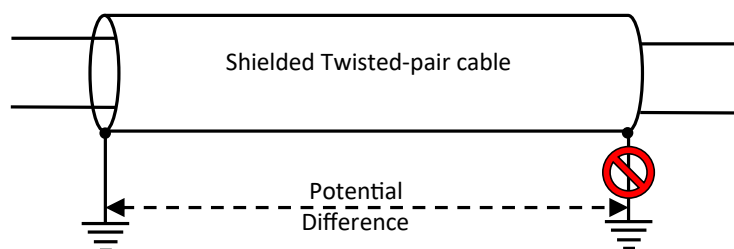

Isolation

Electrical noise can enter the system through the power source for the MPU and I/O. Installing an isolation transformer for all AC sources can correct this problem.

DC power sources should be properly grounded, except for Class II power supplies, which should never be bonded to ground. Switching DC power supplies commonly generate more noise than linear supplies. Typically, switching type supplies work well for analog circuits, but for some circuits where noise can be a factor, linear type supplies may be needed.

Analog wiring should be placed in separate wire ways or wiring bundles. Keep AC and DC wiring separated. Never run analog signal or communications wiring in parallel or in close proximity to high voltage wiring.

Transformers, inductors, VFDs, DC drives, welders, static generators, ultrasonic devices, radio transmitters, receivers, wiring and antennas, along with similar types of devices, generate large amounts of RF interference. DC wiring, analog wiring and communications wiring should be kept as far away from these sorts of devices and their associated input and output wiring as possible.

Devices that generate noise such as those listed above, along with coil-driven devices such as relays, contactors, solenoids, etc., should be placed on a separate power supply from analog circuits. If this is not possible, then great care should be taken to properly suppress the transient voltage spikes from these devices turning on and off. See Chapter 1, “BRX General Installation and Wiring Guidelines” for more information on this subject.

Current Module Tips and Troubleshooting

- Use shielded twisted pair wire. Suggested ADC cables are PLTC3-18-xS-xxxx or PLTC3-18-xSS-xxxx
- Analog circuits follow Ohm's Law. As such, it is important to follow the specifications for impedance in the circuit. If you allow the impedance values to go outside of the specification, damage to the module will occur.
- If your transmitter requires a load resistance higher than 125Ω, you may need to add a resistor in series with the module. Consider the following example for a transmitter being operated from a 24VDC supply with a recommended load resistance of 750 ohms. Since the module has a 125-ohm resistance, you need to add a resistor. Make sure not to exceed the transmitter's maximum load impedance.

$$R = Tr - Mr$$

$$R = 750 - 125$$

$$R \geq 625^*$$

R = Resistor to add
 Tr = Termination Requirement
 Mr = Module resistance (Internal 125 ohms)

* Do not exceed the transmitter's maximum load impedance.

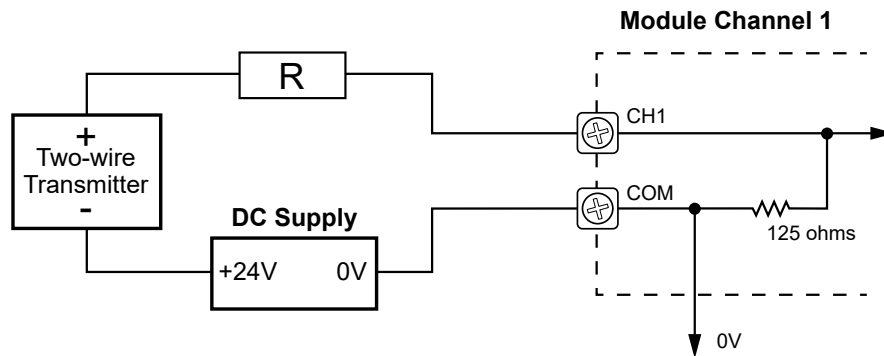

- If you suspect an I/O error, several things could be causing the problem:
 - A blown fuse.
 - A loose terminal block.
 - The 24VDC supply has failed or 24VDC has not been supplied to the I/O common.
 - The I/O point has failed.
- The DC power supply that powers the module should be checked for the negative side to ground voltage being under 0.1 V for both AC and DC. If this voltage is floating, it can cause errors and/or damage to the circuit.

- To test a current input module, use a 1.5 V battery wired across the positive and negative terminals of the channel to check for current. When applied across a current analog input point, a reading of approximately 30% of the full scale value should result.

0–20mA is 0–5VDC across the input resistor

$$1.5V/5V=0.3$$

$$0.3*65535 = \sim 19660 \text{ counts or } 0.3*32767 = \sim 9830 \text{ counts}$$

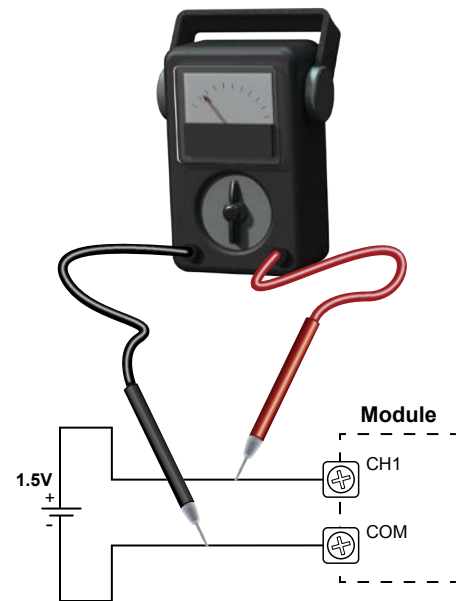

- Most current input modules read voltage across a shunt resistor. It may be easier to test for proper current by measuring the voltage across that shunt resistor and applying Ohm's Law (Voltage/125Ω = Current).

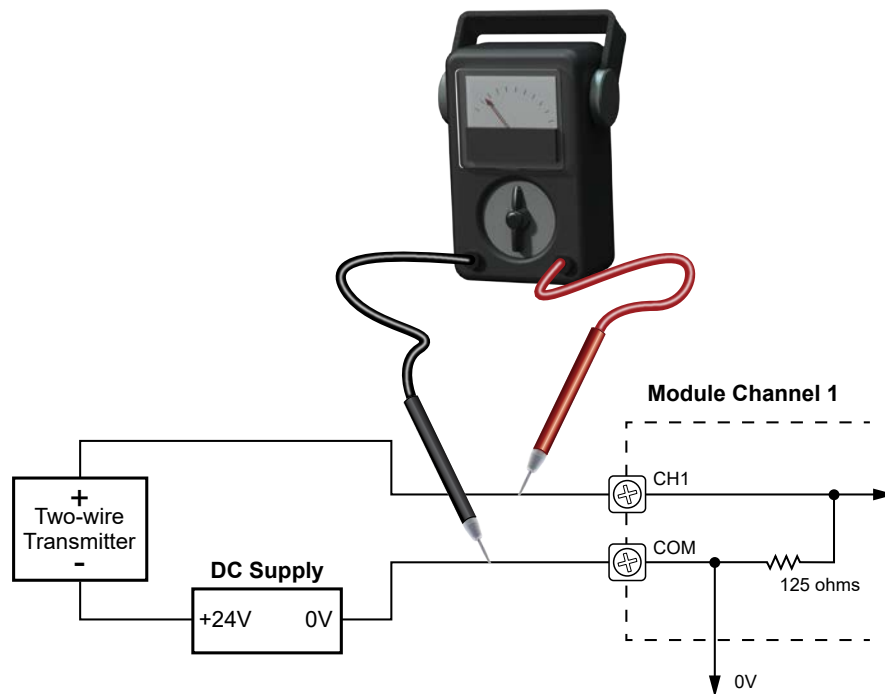

Voltage Module Tips and Troubleshooting

- Use shielded twisted pair wire. Suggested ADC cables are PLTC3-18-xS-xxxx or PLTC3-18-xSS-xxxx.
- Jumper the positive and negative terminals together on unused voltage input channels.
- Analog circuits follow Ohm's Law. As such, it is important to follow the specifications for impedance in the circuit. If you allow the impedance values to go outside of the specification, damage to the module will occur.
- If you suspect an I/O error, several things could be causing the problem:
 - A blown fuse.
 - A loose terminal block.
 - The 24VDC supply has failed or 24VDC has not been supplied to the I/O common.
 - The I/O point has failed.
- The DC power supply that powers the module should be checked for the negative side to ground voltage being under 0.1 V for both AC and DC. If this voltage is floating, it can cause errors and/or damage to the circuit.
- To test the voltage input module, use a 1.5 V battery wired across the positive and negative terminals of the input channel to check for voltage. When applied across a voltage analog input point, a reading of approximately 1.5 V should result.

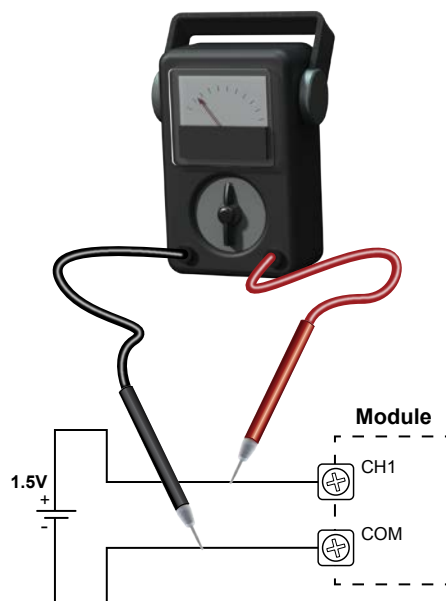

Thermocouple Module Tips and Troubleshooting

- Use shielded thermocouple extension wire of the same type as the thermocouple.
- Do not use terminal blocks that are not designed for thermocouple extension wire.
- Thermocouple wires that have simply been twisted to form a junction will inherently be less accurate than factory-made thermocouples. The use of twist junction thermocouples is not recommended.
- Jumper each of the channel +/- connections together on the module with a short piece of copper wire. This will cause the module to return the measured terminal block temperature for that channel. Does it read the correct ambient temperature of the thermocouple module? If so, there probably isn't anything wrong with the module. This temperature will be several degrees higher than the ambient air temperature of the enclosure.
- With a thermocouple simulator, you have to disable the burnout detection for the module using the module setup in the Do-more! Designer software and download the program to the PLC. This will disable the burnout circuitry, which will cause incorrect readings if left enabled. Even then, it is likely that the module will not read exactly what the simulator is putting out due to the wire differences and the terminal block on the module causing some cold junction error.
- It is possible that the module may be damaged from exceeding the common mode voltage spec, which is 5 Volts. The voltage needs to be measured between each channel on both plus and minus terminals of the module on both AC and DC scales and make sure that it is under 5 Volts maximum. Preferably, the voltage should be less than 0.1V.
- AC power should be checked from neutral to ground. This voltage should be less than 0.1 VAC.
- With grounded thermocouples, take precautions to prevent having a voltage potential between thermocouple tips. A voltage of 1V or greater between tips will skew measurements. For grounded thermocouples, the equipment and thermocouples must be bonded with large-gauge braided wire to the same ground as the PLC.
- The DC power supply that powers the module should be checked for the negative side to ground voltage being under 0.1V for both AC and DC. If this voltage is floating, it can cause errors and/or damage to the circuit.

RTD and Thermistor Troubleshooting

- The easiest way to troubleshoot an RTD or thermistor is with an ohmmeter. If the RTD or thermistor reads open (infinity) or very high resistance, then the RTD or thermistor is bad and should be replaced.
- Intermittent readings can sometimes be caused by a broken RTD or thermistor where the element has cracked but is not fully broken. As it heats up, the crack widens and causes incorrect readings. In this case, the RTD or thermistor should be replaced as well.

BX-04ADM-1 Analog Current Sinking Input

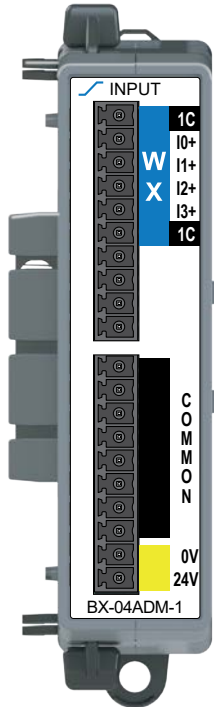

BX-04ADM-1

Analog Input
Expansion Module
4-ch, 0-20mA/4-20mA,
14-bit

Terminal Blocks or
ZIPLink Cables Sold
Separately



We recommend using prewired ZIPLink cables and connection modules. If you wish to hand-wire your module, a removable terminal block is available. See Wiring Termination Selection in this chapter for all options.

Analog Current Sinking Input Specifications

Inputs per Module	4
Commons	1
Module Signal Input Range	0–20mA, 4–20mA (Default)
Signal Resolution	14-bit
Resolution Value of LSB	See Data Range Specifications table
Input Impedance	125Ω±0.1%, 1/10th watt
All Channel Update Rate	45ms (4 channels)
Over Current Circuit Detection Time	< 1second
Maximum Continuous Overload	±28mA
Sample Duration Time	5μs per channel
Hardware Filter Characteristics	Low Pass 1st order, –3dB @ 144Hz
Conversion Method	Successive approximation
Linearity Error (end to end)	±0.09% of range
Input Stability and Repeatability	±0.035% of range (after 10 min. warmup)
Full Scale Calibration Error	±0.1% of range
Offset Calibration Error	±0.1% of range
Accuracy vs. Temperature	±35PPM / °C maximum
Maximum Inaccuracy	0.1% of range (incl. Temperature Drift)
Maximum Crosstalk	–96dB, 1 LSB
Channel to Backplane Isolation	1800VAC applied for one second
Channel to Channel Isolation	None
Loop Fusing (External)	Fast-acting 0.032A recommended
Backplane Power Consumption	0.1 W
External DC Power Required	Class 2 or LPS power supply 24VDC (±20%) 25mA
Heat Dissipation	0.8 W
Weight	98g (3.5 oz)
Agency Approvals	UL 61010-1 and UL 61010-2-201 File E139594, Canada and USA CE (EN 61131-2 EMC, EN 61010-1 and EN 61010-2-201 Safety)
Software Version Required (Do-more! Designer Programming Software)	2.3 or later

IMPORTANT!



Hot-Swapping Information

Note: This device cannot be Hot Swapped.

BX-04ADM-1 Analog Current Sinking Input, continued

Data Range Specifications			
Selection	Description	Raw Counts	μA Per Count
0–20mA	unipolar 0–20mA	0–16383	1.22
4–20mA	unipolar 4–20mA	0–16383	0.977

The module reserves the first 24 bits of unused contiguous space in the X register, aligned to an 8-bit word boundary, for status reporting. Error flags for this module are laid out within its status register space as described in the table below.

Error Flag Specifications									
	MSB								LSB
1st Byte of unused X Registers									
Module Status	-	-	-	-	-	-	Data Not Valid	Missing 24VDC	Self Test Failed
2nd Byte of unused X Registers									
Channel Open(Broken Transmitter)*	-	-	-	-	-	Channel 4	Channel 3	Channel 2	Channel 1
3rd Byte of unused X Registers									
Unused	-	-	-	-	-	-	-	-	-

* 4–20mA mode only. Broken Transmitter bits will turn on below ~3.75 mA.



NOTE: The Data Not Valid flag should always be tested and confirmed to be in the "Off" state in your PLC program before reading from the analog module.

BX-04ADM-1 Analog Current Sinking Input, continued

Analog Current Input Wiring

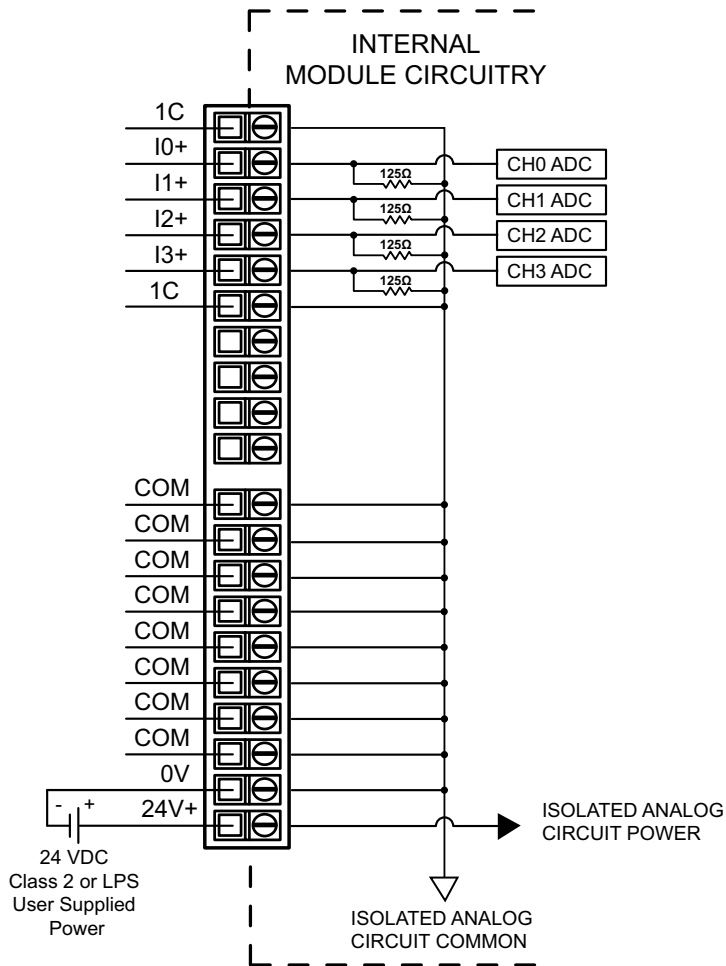

Analog Current Sinking Input Circuits

*An Edison S500-32-R 0.032A fast-acting fuse is recommended for all analog voltage inputs, analog outputs, and current loops.

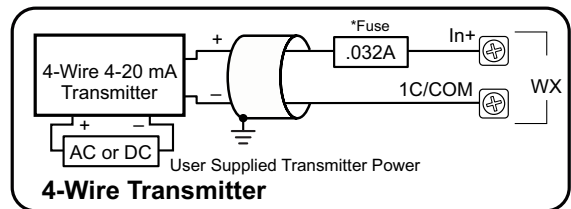
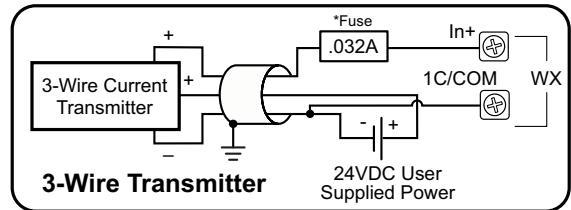
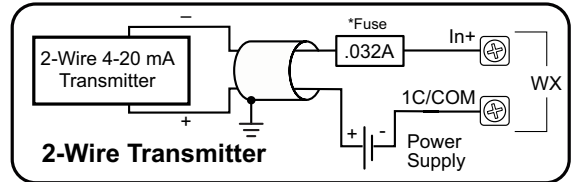

NOTE: Shield should be connected only at one end, to ground at the source device.

BX-04ADM-1 Analog Current Sinking Input, continued

Software Setup

After the module is installed, open the Do-more! Designer programming software, connect to the BRX MPU and open the **Configure Module** dialog as described at the beginning of this chapter.

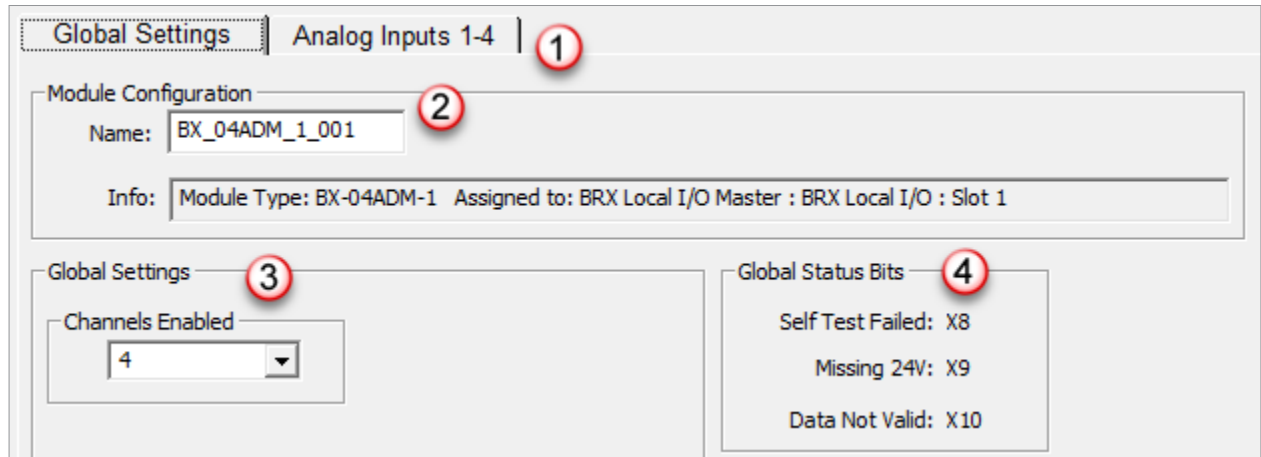

1. The module options are divided into subsets across multiple tabs. Click the appropriate tab to edit the configuration.
2. *Module Configuration*
Name – Each module comes with a default name. This may be changed by the user to better identify the module, if desired.
Info – This is the system description of the module. It is static and may not be changed.
3. *Global Settings*
Channels Enabled – Select how many channels will be used. The default is all channels. Selecting fewer channels may increase the update frequency. See the module specifications for details.
4. *Global Status Bits*
Self Test Failed – This bit will be On if the module has failed its internal self-test. In this case, the module is likely bad and should be replaced.
Missing 24V – This bit will be On if the external 24VDC power is missing. Check the 24VDC power connection on the module terminal block.
Data Not Valid – This bit will be On if the module does not have the latest configuration parameters or the module has not been configured at all. Reload the program into the CPU and power cycle.

BX-04ADM-1 Analog Current Sinking Input, continued

5. *Analog Input x*

These settings are for each channel of the analog module.

Drop-down menu - Select the range of the analog input here.

The *Enable 16 bit unipolar data* option does not apply to this 14-bit module, and is grayed out.

6. *WXx*

Range – The number of Raw counts for the selected channel on the module.

Units/Ct – The amount of current that will equal 1 raw count.

Broken Transmitter – The input register that, when On, will indicate that the loop is broken.

7. *RXx*

Range – The engineering units to which the raw counts are scaled.

Units/Ct – The number of raw counts that will equal 1 scaled engineering unit.

8. *Enable Scaling from WXx to RXx*

WXx Min – The minimum value of the raw counts to scale.

WXx Max – The maximum value of the raw counts to scale.

RXx Min – The minimum value of the engineering units for scaling.

RXx Max – The maximum value of the engineering units for scaling.

Counts/mA – Use these buttons to change the raw scaling to counts or milliamps.

Clamp RXx – If this box is checked, RXx will clamp at the minimum and maximum scaled values.

BX-xxAD-1 Analog Current Sinking Input

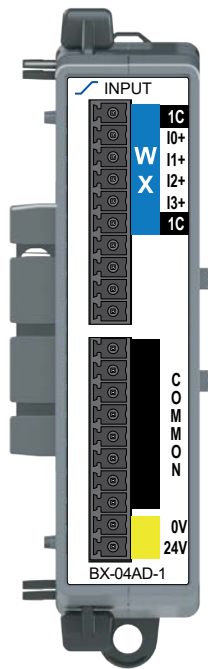

BX-04AD-1
 Analog Input
 Expansion Module
 4-ch, 0-20mA/4-20mA,
 16-bit

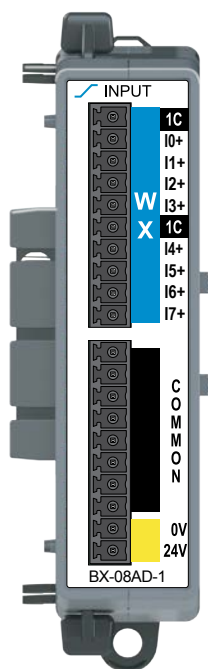

BX-08AD-1
 Analog Input
 Expansion Module
 8-ch, 0-20mA/4-20mA,
 16-bit

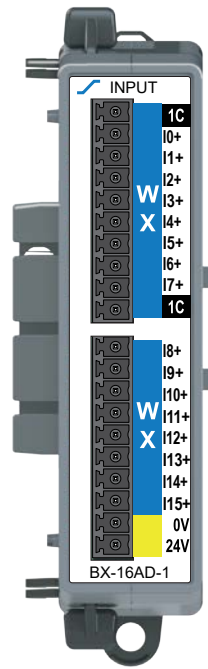

BX-16AD-1
 Analog Input
 Expansion Module
 16-ch, 0-20mA/4-20mA,
 16-bit



Terminal Blocks or
 ZIPLink Cables Sold
 Separately

We recommend using prewired ZIPLink cables and connection modules. If you wish to hand-wire your module, a removable terminal block is available. See Wiring Termination Selection in this chapter for all options.



IMPORTANT!



Hot-Swapping Information

Note: This device cannot be Hot Swapped.

BX-xxAD-1 Analog Current Sinking Input, continued

Analog Current Sinking Input Specifications			
	BX-04AD-1	BX-08AD-1	BX-16AD-1
Inputs per Module	4	8	16
Commons	1		
Module Signal Input Range	0–20mA, 4–20mA (Default)		
Signal Resolution	16-bit, 15-bit (Default)		
Resolution Value of LSB	See Data Range Specifications table		
Input Impedance	125Ω±0.1%, 1/10th watt		256Ω±0.1%, 1/10th watt
All Channel Update Rate	45ms		80ms
Over Current Circuit Detection Time	< 1second		NA
Maximum Continuous Overload	±28mA		
Sample Duration Time	5μs per channel		100μs per channel
Hardware Filter Characteristics	Low Pass 1st order, -3dB @ 144Hz		Low Pass 2nd order, -3dB @ 15KHz
Conversion Method	Successive approximation		
Linearity Error (end to end)	±0.09% of range		
Input Stability and Repeatability (after 10 min. warmup)	±0.035% of range		±0.05% of range
Full Scale Calibration Error	±0.1% of range		
Offset Calibration Error	±0.1% of range		
Accuracy vs. Temperature	±25PPM/°C maximum		
Maximum Inaccuracy	0.1% of range (incl. Temperature Drift)		
Maximum Crosstalk	-96dB, 1 LSB		-90dB, 1 LSB
Channel to Backplane Isolation	1800VAC applied for one second		
Channel to Channel Isolation	None		
Loop Fusing (External)	Fast-acting 0.032A recommended		
Backplane Power Consumption	0.1 W		0.3 W
External DC Power Required	Class 2 or LPS power supply 24VDC (±20%)		
	25mA		75mA
Heat Dissipation	0.8 W	2.5 W	2W
Weight	98g (3.5 oz)		110g (3.9 oz)
Agency Approvals	UL 61010-1 and UL 61010-2-201 File E139594, Canada and USA CE (EN 61131-2 EMC, EN 61010-1 and EN 61010-2-201 Safety)		
Software Version Required (Do-more! Designer Programming Software)	2.3 or later	2.1 or later	2.6 or later

BX-xxAD-1 Analog Current Sinking Input, continued

Data Range Specifications							
Selection	Description	Enable 16 bit Unchecked (15 bit Resolution, Default)			Enable 16 bit Checked (16 bit Resolution)		
		Raw Counts	Casting*	µA Per Count	Raw Counts	Casting*	µA Per Count
0–20mA	unipolar 0–20mA	0–32767	–	0.61	0–65535	WXn:U	0.31
4–20mA	unipolar 4–20mA	0–32767	–	0.49	0–65535	WXn:U	0.24

* For more information on Casting, refer to Help topic DMD0309 in the Do-more! Designer Software.

The module reserves the first 24 bits of unused contiguous space in the X register, aligned to an 8-bit word boundary, for status reporting. Error flags for this module are laid out within its status register space as described in the table below.

Error Flag Specifications								
	MSB							LSB
1st Byte of unused X Registers								
Module Status	-	-	-	-	-	Data Not Valid	Missing 24VDC	Self Test Failed
2nd Byte of unused X Registers								
Channel Open (Broken Transmitter)*	Channel 8	Channel 7	Channel 6	Channel 5	Channel 4	Channel 3	Channel 2	Channel 1
3rd Byte of unused X Registers								
Channel Open** (Broken Transmitter)*	Channel 16	Channel 15	Channel 14	Channel 13	Channel 12	Channel 11	Channel 10	Channel 9

* 4–20mA mode only. Broken Transmitter bits will turn on below ~3.75 mA.

** BX-16AD-1 only.



NOTE: The Data Not Valid flag should always be tested and confirmed to be in the "Off" state in your PLC program before reading from the analog module.

BX-xxAD-1 Analog Current Sinking Input, continued

Analog Current Input Wiring

BX-04AD-1

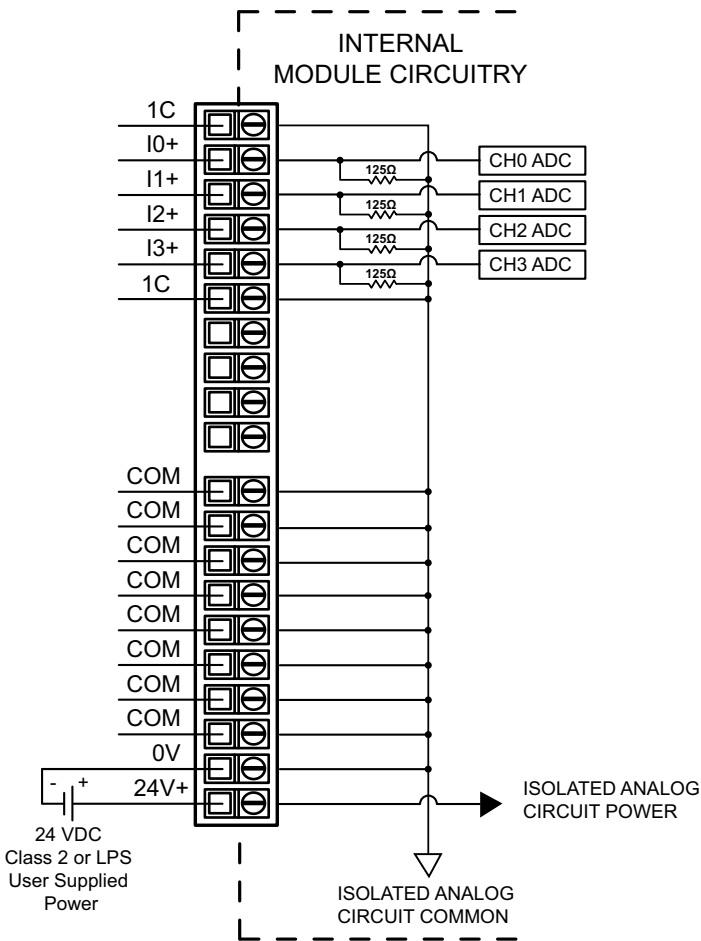

BX-08AD-1

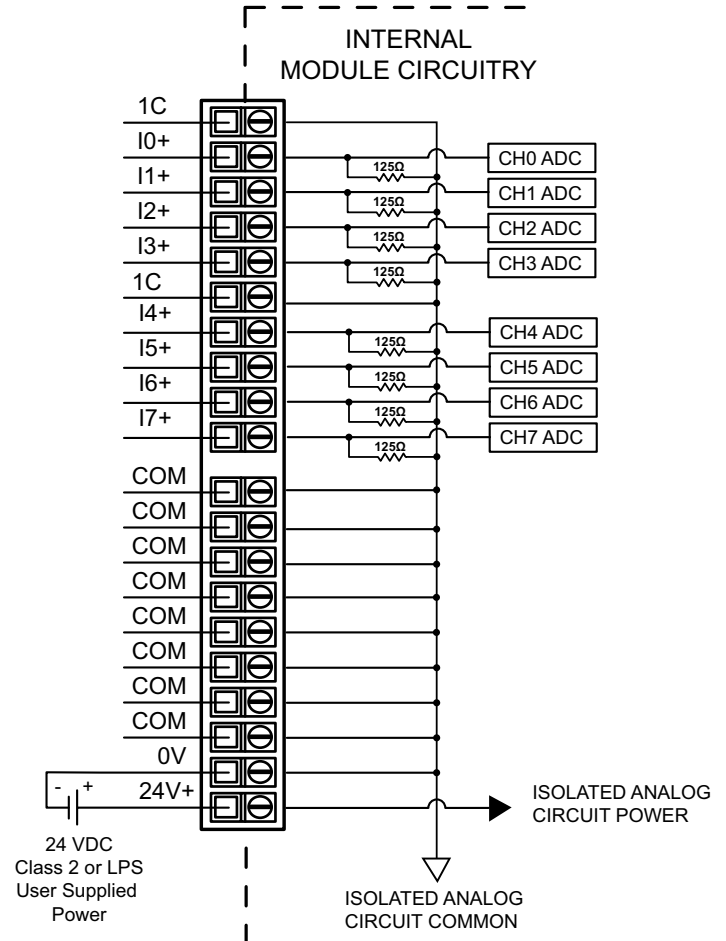

BX-xxAD-1 Analog Current Sinking Input, continued

Analog Current Input Wiring, continued

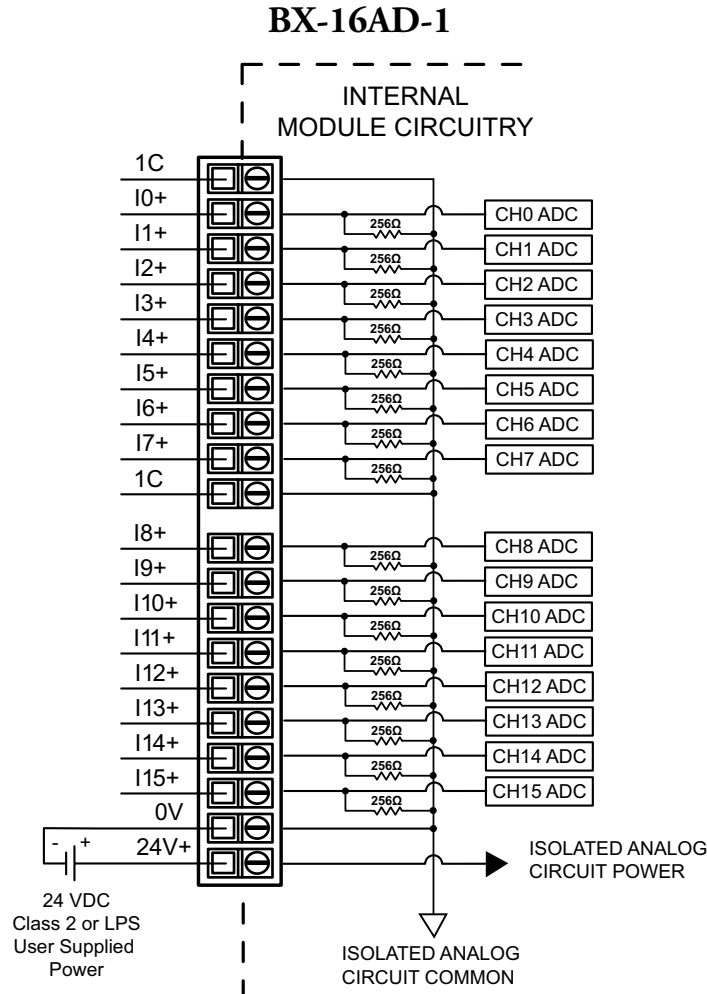

Analog Current Sinking Input Circuits

*An Edison S500-32-R 0.032A fast-acting fuse is recommended for all analog voltage inputs, analog outputs, and current loops.

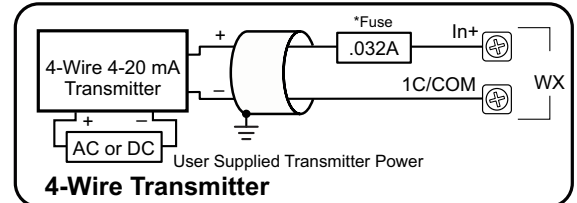
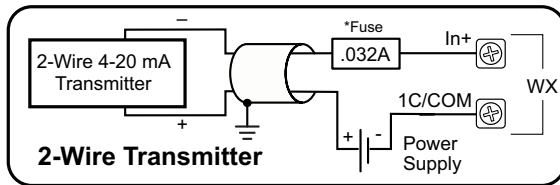

NOTE: Shield should be connected only at one end, to ground at the source device.

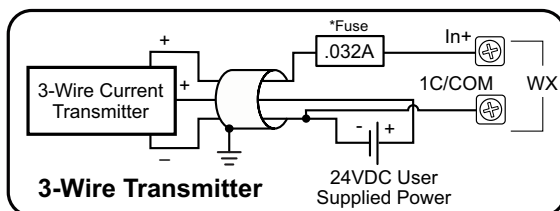

BX-xxAD-1 Analog Current Sinking Input, continued

Software Setup

After the module is installed, open the Do-more! Designer programming software, connect to the BRX MPU and open the **Configure Module** dialog as described at the beginning of this chapter.

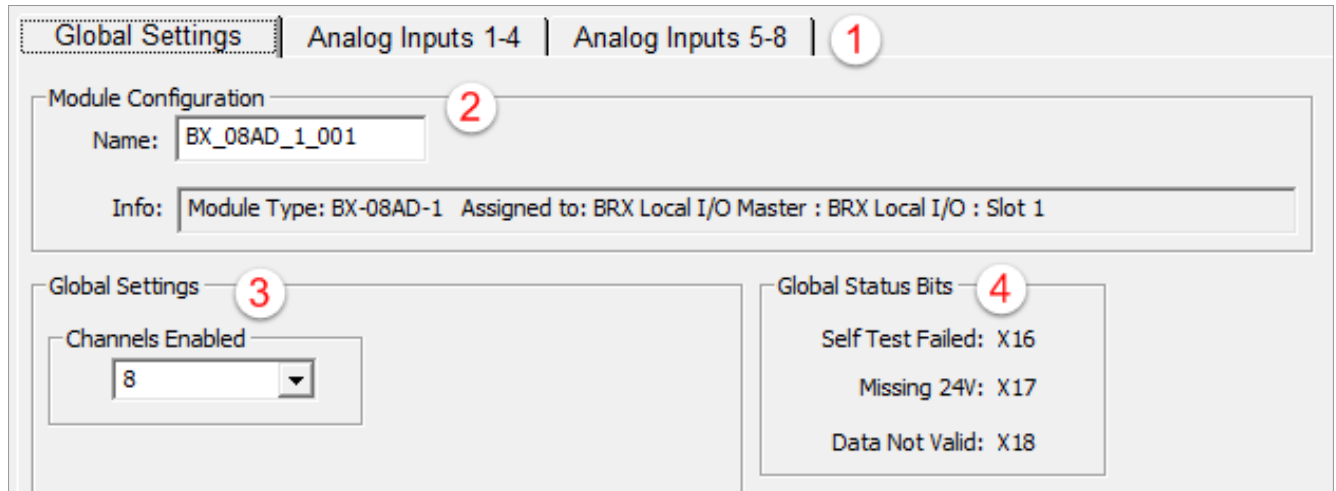

1. The module options are divided into subsets across multiple tabs. Click the appropriate tab to edit the configuration.
2. *Module Configuration*

Name – Each module comes with a default name. This may be changed by the user to better identify the module if desired.

Info – This is the system description of the module. It is static and may not be changed.

3. *Global Settings*

Channels Enabled – Select how many channels will be used. The default is all channels. Selecting fewer channels may increase the update frequency. See the module specifications for details.

4. *Global Status Bits*

Self Test Failed – This bit will be On if the module has failed its internal self-test. In this case, the module is likely bad and should be replaced.

Missing 24V – This bit will be On if the external 24VDC power is missing. Check the 24VDC power connection on the module terminal block.

Data Not Valid – This bit will be On if the module does not have the latest configuration parameters or the module has not been configured at all. Reload the program into the CPU and power cycle.

BX-xxAD-1 Analog Current Sinking Input, continued

5. *Analog Input x*

These settings are for each channel of the analog module.

Drop-down menu - Select the range of the analog input here.

Enable 16 bit unipolar data – Check this box to change the raw count range from a signed decimal bipolar data format to an unsigned decimal data format. This may require that Casting be used in the program in order to properly access the data. Refer to the chart of Data Range Specifications earlier in this chapter to see if the registers must be accessed with Casting.

6. *WXx*

Range – The number of Raw counts for the selected channel on the module

Units/Ct – The amount of current that will equal 1 raw count.

Broken Transmitter – The input register that, when On, will indicate that the loop is broken.

7. *RXx*

Range – The engineering units to which the raw counts are scaled.

Units/Ct – The number of raw counts that will equal 1 scaled engineering unit.

8. *Enable Scaling from WXx to RXx*

WXx Min – The minimum value of the raw counts to scale.

WXx Max – The maximum value of the raw counts to scale.

RXx Min – The minimum value of the engineering units for scaling.

RXx Max – The maximum value of the engineering units for scaling.

Counts/mA – Use these buttons to change the raw scaling to counts or milliamps.

Clamp RXx – If this box is checked, RXx will clamp at the minimum and maximum scaled values.

BX-xxAD-2B Analog Voltage Input

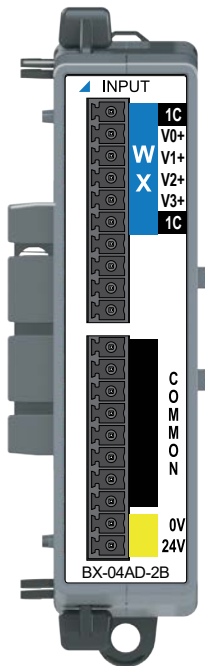

BX-04AD-2B

Analog Input Expansion Module
4-ch, ± 10 VDC, ± 5 VDC,
0–5 VDC, 0–10 VDC,
16-bit

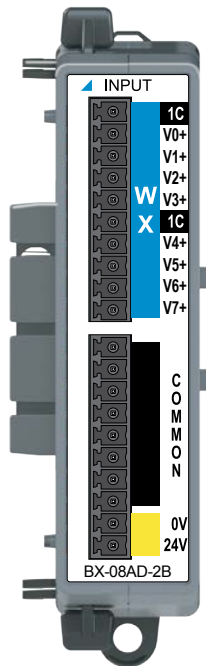

BX-08AD-2B

Analog Input Expansion Module
8-ch, ± 10 VDC, ± 5 VDC,
0–5 VDC, 0–10 VDC,
16-bit

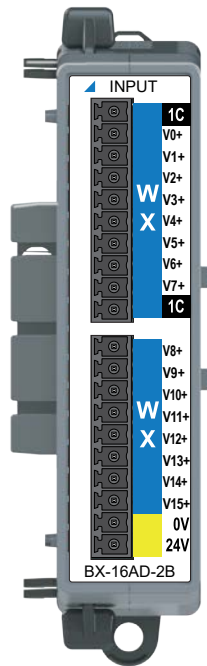

BX-16AD-2B

Analog Input Expansion Module
16-ch, ± 10 VDC, ± 5 VDC,
0–5 VDC, 0–10 VDC,
16-bit



Terminal Blocks or
Z/PLink Cables Sold
Separately

We recommend using prewired Z/PLink cables and connection modules.
If you wish to hand-wire your module, a removable terminal block is available. See Wiring Termination Selection in this chapter for all options.



IMPORTANT!



Hot-Swapping Information

Note: This device cannot be Hot Swapped.

BX-xxAD-2B Analog Voltage Input, continued

Analog Voltage Input Specifications			
	BX-04AD-2B	BX-08AD-2B	BX-16AD-2B
Inputs per Module	4	8	16
Commons	1		
Module Signal Input Range	±10 VDC, ±5 VDC, 0–5 VDC, 0–10 VDC (Default)		
Signal Resolution	16-bit, 15-bit (Default)		
Resolution Value of LSB	See Data Range Specifications table		
Input Impedance	>10MΩ		>1MΩ
All Channel Update Rate	45ms		100ms
Sample Duration Time	5µs per channel		100µs per channel
Hardware Filter Characteristics	Low Pass 2nd order, -3dB @ 15kHz		
Conversion Method	Successive approximation		
Accuracy vs. Temperature	±25PPM/°C maximum		
Maximum Inaccuracy	0.15% of full range (over temp)		
Linearity Error (end to end)	±0.03%		±0.09%
Input Stability and Repeatability	±0.06% of range (after 10 min. warmup)		
Full Scale Calibration Error	±0.08% of range		±0.1% of range
Offset Calibration Error	±0.08% of range		±0.1% of range
Maximum Crosstalk	-96dB, 1 LSB		-90dB, 1 LSB
Channel to Backplane Isolation	1800VAC applied for one second		
Channel to Channel Isolation	None		
Loop Fusing (External)	Fast-acting 0.032A recommended		
Backplane Power Consumption	0.1 W		0.3 W
External DC Power Required	Class 2 or LPS power supply 24VDC (±20%)		
	25mA		75mA
Heat Dissipation	0.8 W		1W
Weight	98g (3.5 oz)		110g (3.9 oz)
Agency Approvals	UL 61010-1 and UL 61010-2-201 File E139594, Canada and USA CE (EN 61131-2 EMC, EN 61010-1 and EN 61010-2-201 Safety)		
Software Version Required (Do-more! Designer Programming Software)	2.3 or later	2.1 or later	2.6 or later

BX-xxAD-2B Analog Voltage Input, continued

Data Range Specifications							
Selection	Description	Enable 16 bit Unchecked (15 bit Resolution, Default) ¹			Enable 16 bit Checked (16 bit Resolution)		
		Raw Counts	Casting ²	µV Per Count	Raw Counts	Casting ²	µV Per Count
0–10V	unipolar 10VDC	0–32767	-	305	0–65535	WXn:U	152
0–5V	unipolar 5VDC	0–32767	-	152	0–65535	WXn:U	76
±10V	bipolar 10VDC	-	-	-	-32768 to 32767	-	305
±5V	bipolar 5VDC	-	-	-	-32768 to 32767	-	152

1. Bipolar ranges default to 16-bit resolution.

2. For more information on Casting, refer to Help topic DMD0309 in the Do-more! Designer Software.

The module reserves the first 24 bits of unused contiguous space in the X register, aligned to an 8-bit word boundary, for status reporting. Error flags for this module are laid out within its status register space as described in the table below.

Error Flag Specifications									
	MSB							LSB	
1st Byte of unused X Registers									
Module Status	-	-	-	-	-	-	Data Not Valid	Missing 24VDC	Self Test Failed
2nd Byte of unused X Registers									
Channel Out of Range	Channel 8	Channel 7	Channel 6	Channel 5	Channel 4	Channel 3	Channel 2	Channel 1	
3rd Byte of unused X Registers									
Channel Out of Range*	Channel 16	Channel 15	Channel 14	Channel 13	Channel 12	Channel 11	Channel 10	Channel 9	

* BX-16AD-2B only.



NOTE: The Data Not Valid flag should always be tested and confirmed to be in the "Off" state in your PLC program before reading from the analog module.

BX-xxAD-2B Analog Voltage Input, continued

Analog Voltage Input Wiring

BX-04AD-2B

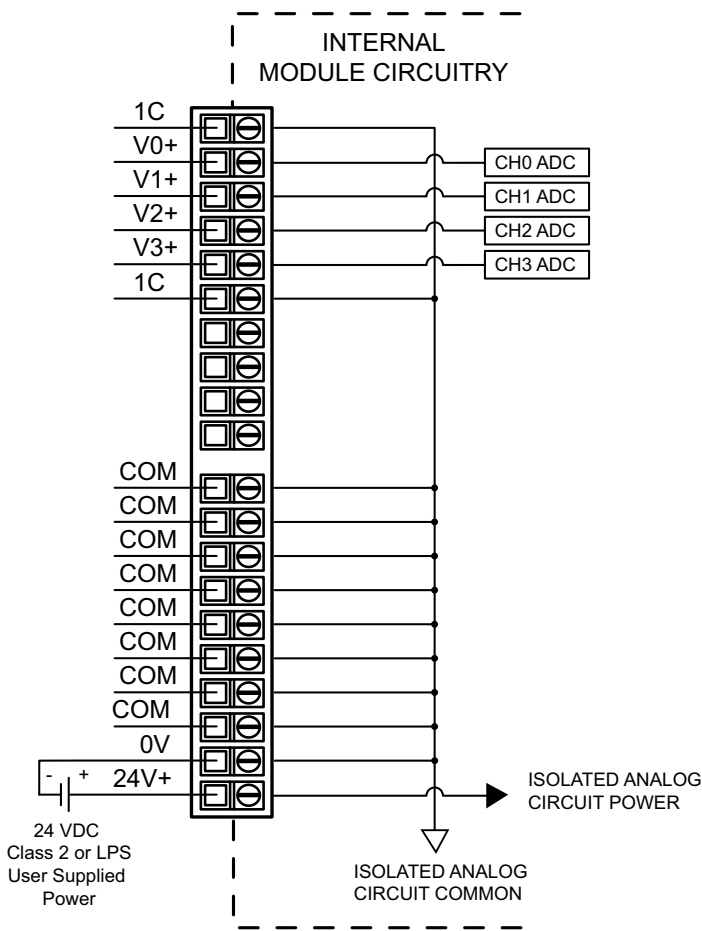

BX-08AD-2B

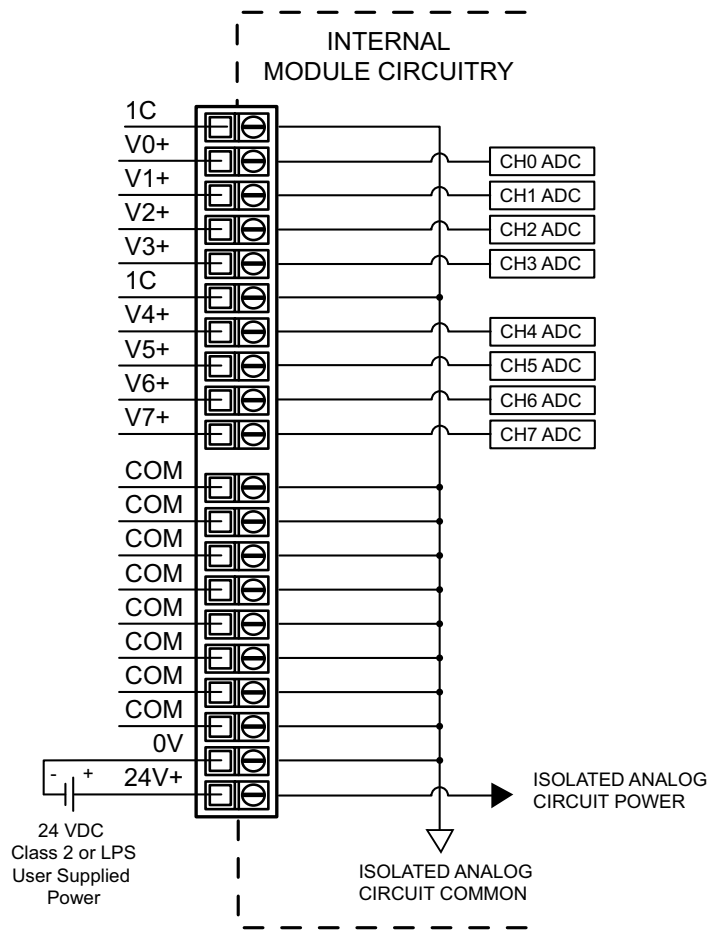

BX-xxAD-2B Analog Voltage Input, continued

Analog Voltage Input Wiring, continued

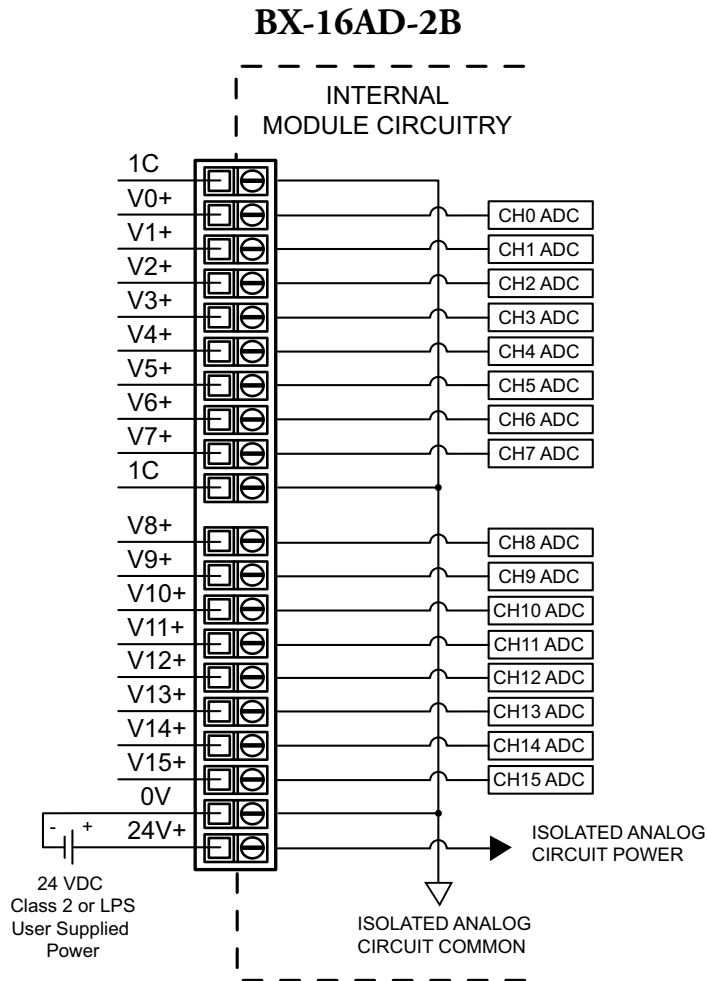

Analog Voltage Input Circuits

*An Edison S500-32-R 0.032A fast-acting fuse is recommended for all analog voltage inputs, analog outputs, and current loops.

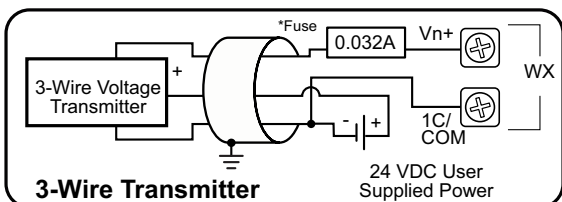
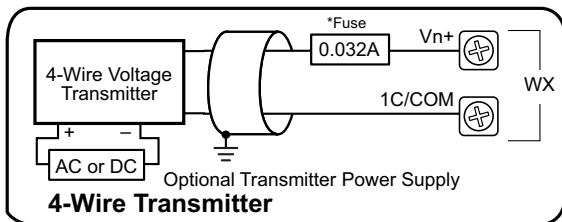

NOTE: For maximum accuracy, jumper unused inputs to common.

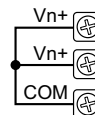

NOTE: Shield should be connected only at one end, to ground at the source device.

BX-xxAD-2B Analog Voltage Input, continued

Software Setup

After the module is installed, open the Do-more! Designer programming software, connect to the BRX MPU and open the Configure Module dialog as described at the beginning of this chapter.

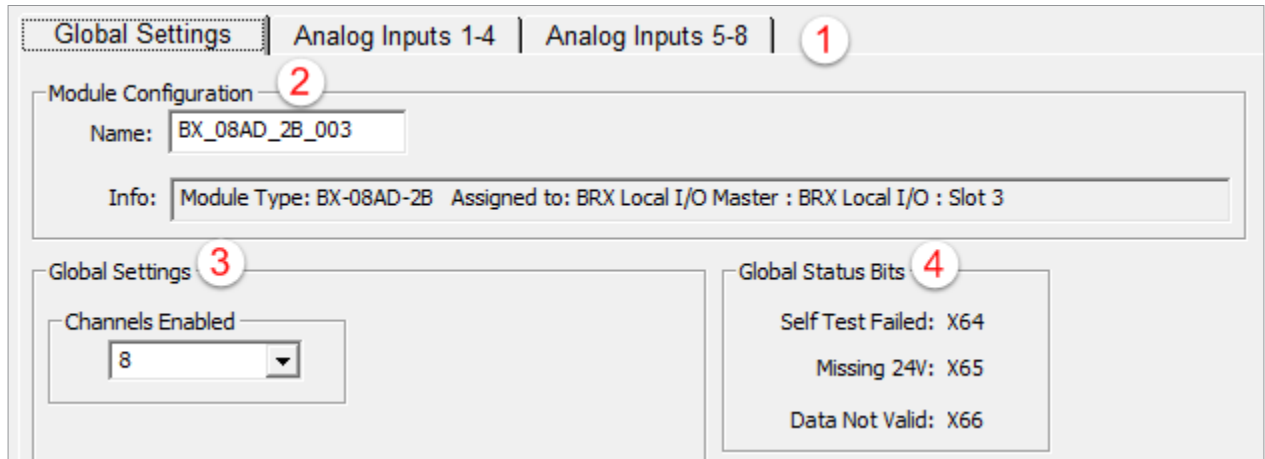

1. The module options are divided into subsets across multiple tabs. Click the appropriate tab to edit the configuration.

2. *Module Configuration*

Name – Each module comes with a default name. This may be changed by the user to better identify the module if desired.

Info – This is the system description of the module. This is static and may not be changed.

3. *Global Settings*

Channels Enabled – Select how many channels will be used. The default is all channels. Selecting fewer channels may increase the update frequency. See the module specifications for details.

4. *Global Status Bits*

Self Test Failed – This bit will be On if the module has failed its internal self-test. In this case, the module is likely bad and should be replaced.

Missing 24V – This bit will be On if the external 24VDC power is missing. Check the 24VDC power connection on the module terminal block.

Data Not Valid – This bit will be On if the module does not have the latest configuration parameters or the module has not been configured at all. Reload the program into the CPU and power cycle.

BX-xxAD-2B Analog Voltage Input, continued

5. *Analog Input x*

These settings are for each channel of the analog module.

Drop-down menu - Select the range of the analog input here.

Enable 16 bit unipolar data – Check this box to change the raw count range from a signed decimal bipolar data format to an unsigned decimal data format. This may require that Casting be used in the program in order to properly access the data. Refer to the chart of Data Range Specifications earlier in this chapter to see if the registers must be accessed with Casting.

6. *WXx*

Range – The number of Raw counts for the selected channel on the module.

Units/Ct – The amount of voltage that will equal 1 raw count.

Out of Range – The input register that, when On, will indicate that the voltage is outside of the selected range.

7. *RXx*

Range – The engineering units to which the raw counts are scaled.

Units/Ct – The number of raw counts that will equal 1 scaled engineering unit.

8. *Enable Scaling from WXx to RXx*

WXx Min – The minimum value of the raw counts to scale.

WXx Max – The maximum value of the raw counts to scale.

RXx Min – The minimum value of the engineering units for scaling.

RXx Max – The maximum value of the engineering units for scaling.

Counts/VDC – Use these buttons to change the raw scaling to counts or volts.

Clamp RXx – If this box is checked, RXx will clamp at the minimum and maximum scaled values.

BX-xxAD-3 Universal Analog Input

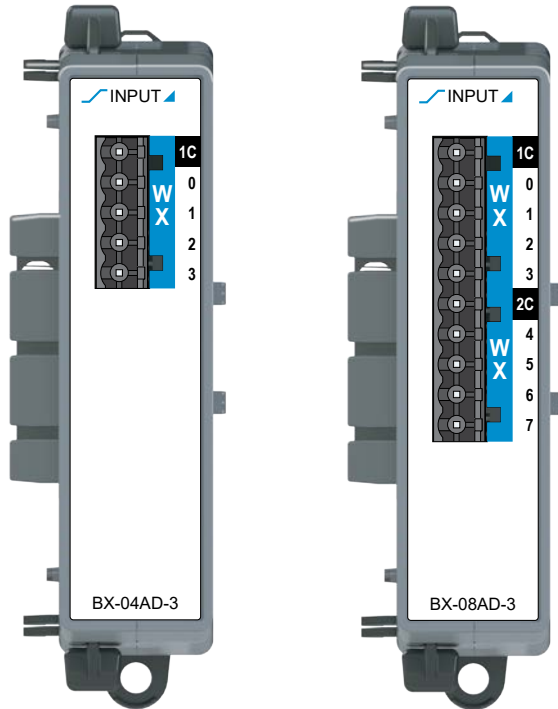

Universal Current/Voltage Sinking Input Specifications		
	BX-04AD-3	BX-08AD-3
Inputs per Module	4	8
Commons	1	2
Module Signal Input Range	0–20mA, 4–20mA, ±10 VDC, ±5 VDC, 0–5 VDC (Default), 0–10 VDC	
Signal Resolution	16-bit at ±10V or ±20mA*	
Resolution Value of LSB	See Data Range Specifications table	
Input Impedance	Current Input	249Ω±0.1%, 1/10th watt
	Voltage Input	100kΩ
All Channel Update Rate	1.2 ms	
Over Current Circuit Detection Time	< 1second	
Maximum Continuous Overload	±40mA current mode, ±20V voltage mode	
Sample Duration Time	1.2 ms	
Hardware Filter Characteristics	Active Low Pass, -3dB @ 1kHz	
Conversion Method	Delta Sigma	
Linearity Error (end to end)	±0.1% of HW Full Scale (65 counts)	
Input Stability and Repeatability (after 10 min. warmup)	±0.02% of HW Full Scale (13 counts)	
Full Scale Calibration Error	±0.1% of HW Full Scale (65 counts)	
Offset Calibration Error	±0.05% of HW Full Scale (32 counts)	
Accuracy vs. Temperature	±25PPM / °C maximum	
Maximum Inaccuracy	±0.2% of HW Full Scale (130 counts)	
Maximum Crosstalk	1 count	
Channel to Backplane Isolation	1500VAC applied for one second, 1C to 2C	
Channel to Channel Isolation	None	
Loop Fusing (External)	Fast-acting 0.032A recommended	
Backplane Power Consumption	1.5 W	2.5 W
Heat Dissipation	2.25 W	3.25 W
Weight	98g [3.5 oz]	
Agency Approvals	UL 61010-2 File E185989, Canada and USA	
Software Version Required (Do-more! Designer Programming Software)	2.7 or later	

* 16-bit resolution is only available when a bipolar input range is selected.

BX-04AD-3

Analog Input
Expansion Module
4-ch, ±20mA or ±10V,
16-bit*

BX-08AD-3

Analog Input
Expansion Module
8-ch, ±20mA or ±10V,
16-bit*

Terminal Blocks or
ZIPLink Cables Sold
Separately



We recommend using prewired ZIPLink cables and connection modules. If you wish to hand-wire your module, a removable terminal block is available. See Wiring Termination Selection in this chapter for all options.

IMPORTANT!



Hot-Swapping Information

Note: This device cannot be Hot Swapped.

BX-xxAD-3 Universal Analog Input, continued

Data Range Specifications				
Selection	Description	Raw Counts	Casting ¹	Per Count
-20–20mA	bipolar -20–20mA	-32768 to 32767	-	0.61 μ A
4–20mA	unipolar 4–20mA	6553–32767	-	0.61 μ A
0–10V	unipolar 10VDC	0–32767	-	305 μ V
0–5V	unipolar 5VDC	0–32767	-	305 μ V
\pm 10V	bipolar 10VDC	-32768 to 32767	-	305 μ V
\pm 5V	bipolar 5VDC	-32768 to 32767	-	305 μ V

1. For more information on Casting, refer to Help topic DMD0309 in the Do-more! Designer Software.

The module reserves the first 8 bits of unused contiguous space in the X register, aligned to an 8-bit word boundary, for status reporting. Error flags for this module are laid out within its status register space as described in the table below.

Error Flag Specifications								
	MSB							LSB
1st Byte of unused X Registers								
Out of Range	Channel 8	Channel 7	Channel 6	Channel 5	Channel 4	Channel 3	Channel 2	Channel 1

Channel Bit Error Flag is set when a channel's input signal meets the conditions in the table below.

Channel Bit Error Conditions	
Selected Data Range	Error Condition
-20–20mA	< -20.0 mA or > 20.0 mA
4–20mA	< 2.0 mA (i.e., Broken Transmitter, no upper error condition for 4–20mA)
0–10V	< -0.05 V or > 10.0 V
0–5V	< -0.05 V or > 5.05 V
\pm 10V	< -10.0 V or > 10.0 V
\pm 5V	< -5.05 V or > 5.05 V

BX-xxAD-3 Universal Analog Input, continued

Analog Current/Voltage Input Wiring

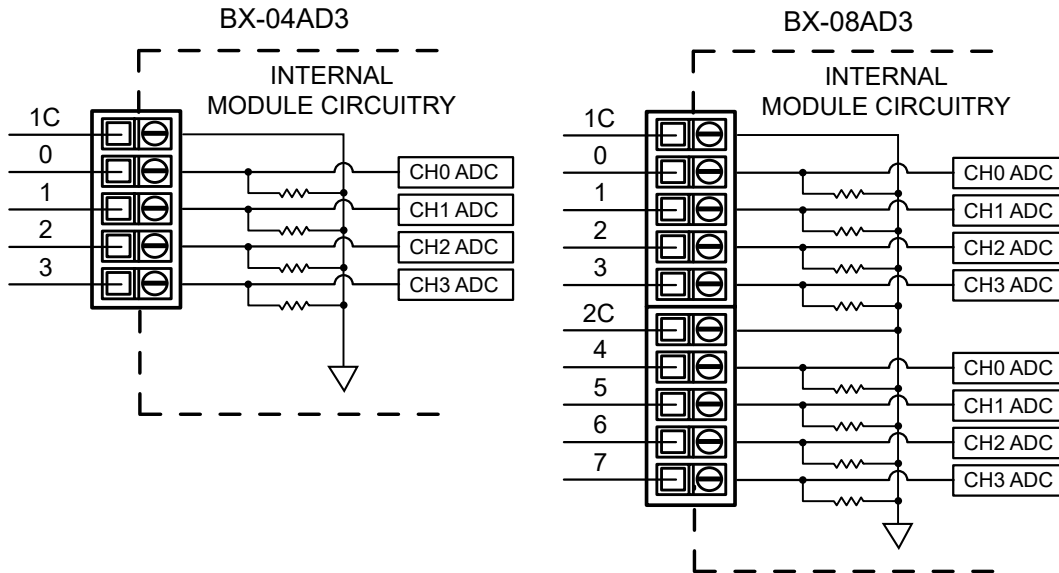

Analog Current Sinking Input Circuits

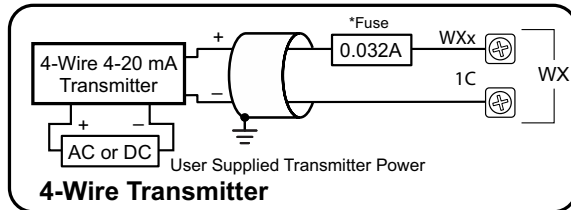
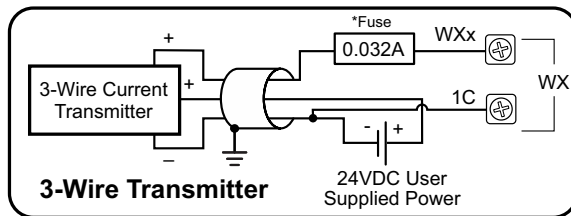
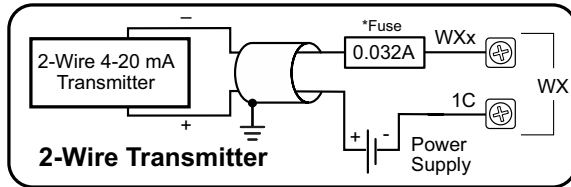

*NOTE: An Edison S500-32-R 0.032A fast-acting fuse is recommended for all analog voltage inputs, analog outputs, and current loops.

Analog Voltage Input Circuits

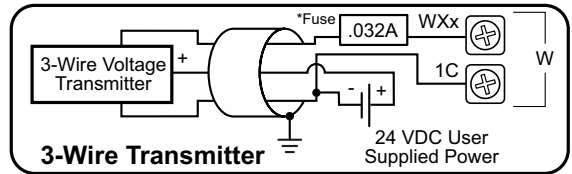
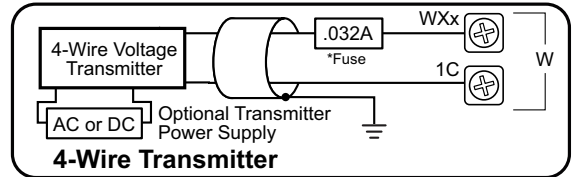

NOTE: Shield should be connected only at one end, to ground at the source device.

BX-xxAD-3 Universal Analog Input, continued

Software Setup

After the module is installed, open the Do-more! Designer programming software, connect to the BRX MPU and open the Configure Module dialog as described at the beginning of this chapter.

Setup BX-08AD-3 Module

Module Configuration Name: **BX_08AD_3_001** Info: Module Type: BX-08AD-3 Assigned to: BRX Local I/O Master : BRX Local I/O : Slot 1

Analog Inputs 0-3 | Analog Inputs 4-7 |

Analog Input 0
 0 - 5VDC
 Filter Time: 0.00
 Time is in seconds. Enter 0 to disable.

WX1
 Range: 0 - 32767
 Resolution: 15 bits
 Units/Ct: 305uV
 Out of Range: X16

RX1
 Range: 0.00 - 100.00
 Units/Ct: 0.003052

Enable Scaling from WX1 to RX1

WX1 Min: 0 RX1 Min: 0
 WX1 Max: 32767 RX1 Max: 100

Counts VDC Clamp RX1

The module options are divided into subsets across multiple tabs. Click the appropriate tab to edit the configuration.

1. *Analog Input x*

These settings are for each channel of the analog module.

Drop-down menu – Select the range of the analog input here.

Filter Time – Time to average the Analog signal in seconds.

2. *WXx*

Range – The number of Raw counts for the selected channel on the module.

Units/Ct – The amount of voltage that will equal 1 raw count.

Out of Range – The input register that, when On, will indicate that the voltage is outside of the selected range.

3. *RXx*

Range – The engineering units to which the raw counts are scaled.

Units/Ct – The number of raw counts that will equal 1 scaled engineering unit.

4. *Enable Scaling from WXx to RXx*

WXx Min – The minimum value of the raw counts to scale.

WXx Max – The maximum value of the raw counts to scale.

RXx Min – The minimum value of the engineering units for scaling.

RXx Max – The maximum value of the engineering units for scaling.

Counts/VDC – Use these buttons to change the raw scaling to counts or volts.

Clamp RXx – If this box is checked, RXx will clamp at the minimum and maximum scaled values.

BX-xxTHM Thermocouple Input

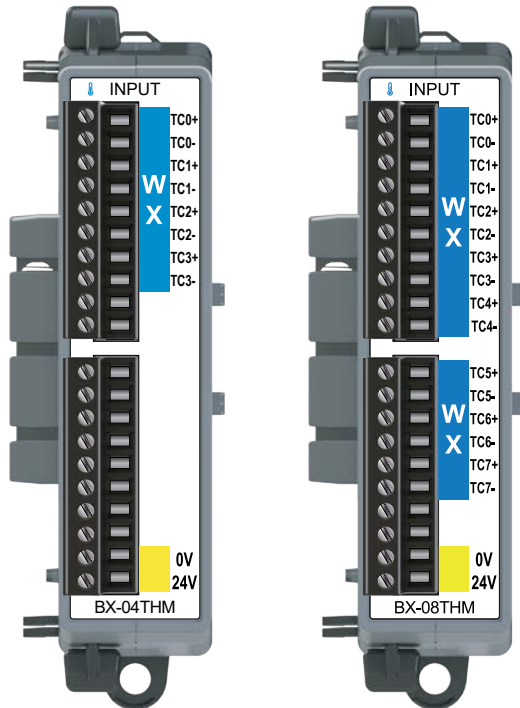

BX-04THM

Temperature Input
Expansion Module
4-pt Thermocouple
Temperature Input

BX-08THM

Temperature Input
Expansion Module
8-pt Thermocouple
Temperature Input

BX-RTB10 Terminal Blocks Included.
The BX-RTB10-1 or BX-RTB10-2 can
also be used and can be purchased
separately.



NOTE: This device does not support
ZIPLink Wiring Systems.

IMPORTANT!



Hot-Swapping Information

Note: This device cannot be
Hot Swapped.



Thermocouple Input Specifications

	BX-04THM	BX-08THM
Input Channels	4 Differential	8 Differential
Commons	0	
Input Impedance	Rev. B2 or lower: >5M Ω Rev. B3 or higher: >1M Ω	Rev. A1: >5M Ω Rev. A2 or higher: >1M Ω
Resolution	16-bit, 0.1 $^{\circ}$ (C or F) See Data Range Specifications table	
Thermocouple Input Ranges	Type J: -190 $^{\circ}$ to 760 $^{\circ}$ C (-310 $^{\circ}$ to 1400 $^{\circ}$ F) (Default) Type E: -210 $^{\circ}$ to 1000 $^{\circ}$ C (-346 $^{\circ}$ to 1832 $^{\circ}$ F) Type K: -150 $^{\circ}$ to 1372 $^{\circ}$ C (-238 $^{\circ}$ to 2502 $^{\circ}$ F) Type R: 65 $^{\circ}$ to 1768 $^{\circ}$ C (149 $^{\circ}$ to 3214 $^{\circ}$ F) Type S: 65 $^{\circ}$ to 1768 $^{\circ}$ C (149 $^{\circ}$ to 3214 $^{\circ}$ F) Type T: -230 $^{\circ}$ to 400 $^{\circ}$ C (-382 $^{\circ}$ to 752 $^{\circ}$ F) Type B: 529 $^{\circ}$ to 1820 $^{\circ}$ C (984 $^{\circ}$ to 3308 $^{\circ}$ F) Type N: -70 $^{\circ}$ to 1300 $^{\circ}$ C (-94 $^{\circ}$ to 2372 $^{\circ}$ F) Type C: 65 $^{\circ}$ to 2320 $^{\circ}$ C (149 $^{\circ}$ to 4208 $^{\circ}$ F)	
Cold Junction Compensation	Automatic	
Thermocouple Linearization	Automatic	
Accuracy vs. Temperature	\pm 50PPM per $^{\circ}$ C (maximum)	
Maximum Inaccuracy–Temperature	\pm 3 $^{\circ}$ C maximum (excluding thermocouple error) (including temperature drift)	
Linear Voltage Input Ranges	0–39mV \pm 39mV \pm 78mV 0–156mV \pm 156mV 0–1.25 V	
Maximum Inaccuracy–Voltage	0.06% @ 25 $^{\circ}$ C, 0.10% @ 0–60 $^{\circ}$ C	
All Channel Update Rate	2.16 s	
Sample Duration Time	270ms	
Open Circuit Detection Time	Within 2s	
Maximum Ratings	Fault protected inputs to \pm 50V	
Common Mode Range	0.6 V (@ 16-bit Resolution)	
Common Mode Rejection	100dB @ DC and 130dB @ 60Hz	
Conversion Method	Sigma-Delta	
Backplane Power Consumption	0.1 W	
External DC Power Required	Class 2 or LPS power supply 24VDC (\pm 20%) 25mA	
Heat Dissipation	0.8 W	
Weight	98g (3.5 oz)	
Agency Approvals	UL 61010-1 and UL 61010-2-201 File E139594, Canada and USA CE (EN 61131-2 EMC, EN 61010-1 and EN 61010-2-201 Safety)	
Software Version Required (Do-more! Designer Programming Software)	2.1 or later	2.3 or later

BX-xxTHM Thermocouple Input, continued

Data Range Specifications							
Selection	Description	Enable 16 bit Unchecked (15 bit Resolution, Default) ¹			Enable 16 bit Checked (16 bit Resolution)		
		Raw Counts	Casting ²	µV Per Count	Raw Counts ³	Casting ²	µV Per Count
Type J	Type J	-	-		°C: -1900 to 7600 °F: -3100 to 14000	-	-
Type E	Type E	-	-		°C: -2100 to 10000 °F: -3460 to 18320	-	-
Type K	Type K	-	-		°C: -1500 to 13720 °F: -2380 to 25020	-	-
Type R	Type R	-	-		°C: 650 to 17680 °F: 1490 to 32140	-	-
Type S	Type S	-	-		°C: 650 to 17680 °F: 1490 to 32140	-	-
Type T	Type T	-	-		°C: -2300 to 4000 °F: -380 to 7520	-	-
Type B	Type B	-	-		°C: 5290 to 18200 °F: 9840 to 33080	WXn:U	-
Type N	Type N	-	-		°C: -700 to 13000 °F: -940 to 23720	-	-
Type C	Type C	-	-		°C: 650 to 23200 °F: 1490 to 42080	WXn:U	-
0–39 mVDC	Unipolar 39 mVDC	0–32767	-	1.2	0–65535	WXn:U	0.6
–39–39 mVDC	Bipolar 39 mVDC	-	-		–32768 to 32767	-	1.2
–78–78 mVDC	Bipolar 78 mVDC	-	-		–32768 to 32767	-	2.4
0–156 mVDC	Unipolar 156 mVDC	0–32767	-	4.8	0–65535	WXn:U	2.4
–156–156 mVDC	Bipolar 156 mVDC	-	-		–32768 to 32767	-	4.8
0–1.25 VDC	Unipolar 1.25 VDC	0–32767	-	38.1	0–65535	WXn:U	19.1

1. Thermocouple and bipolar ranges default to 16-bit resolution.

2. For more information on Casting, refer to Help topic DMD0309 in the Do-more! Designer Software.

3. Temperatures have one implied decimal place (e.g., raw count of -1900 is -190.0°).

The module reserves the first 24 bits of unused contiguous space in the X register, aligned to an 8-bit word boundary, for status reporting. Error flags for this module are laid out within its status register space as described in the table below.

Error Flag Specifications									
	MSB							LSB	
1st Byte of unused X Registers									
Module Status	-	-	-	-	-	-	Data Not Valid	Missing 24VDC	Self Test Failed
2nd Byte of unused X Registers									
Channel Out of Range	Channel 8	Channel 7	Channel 6	Channel 5	Channel 4	Channel 3	Channel 2	Channel 1	
3rd Byte of unused X Registers									
Burn Out	Channel 8	Channel 7	Channel 6	Channel 5	Channel 4	Channel 3	Channel 2	Channel 1	



NOTE: The Data Not Valid flag should always be tested and confirmed to be in the "Off" state in your PLC program before reading from the analog module.

BX-xxTHM Thermocouple Input, continued

Analog Thermocouple/Voltage Input Wiring

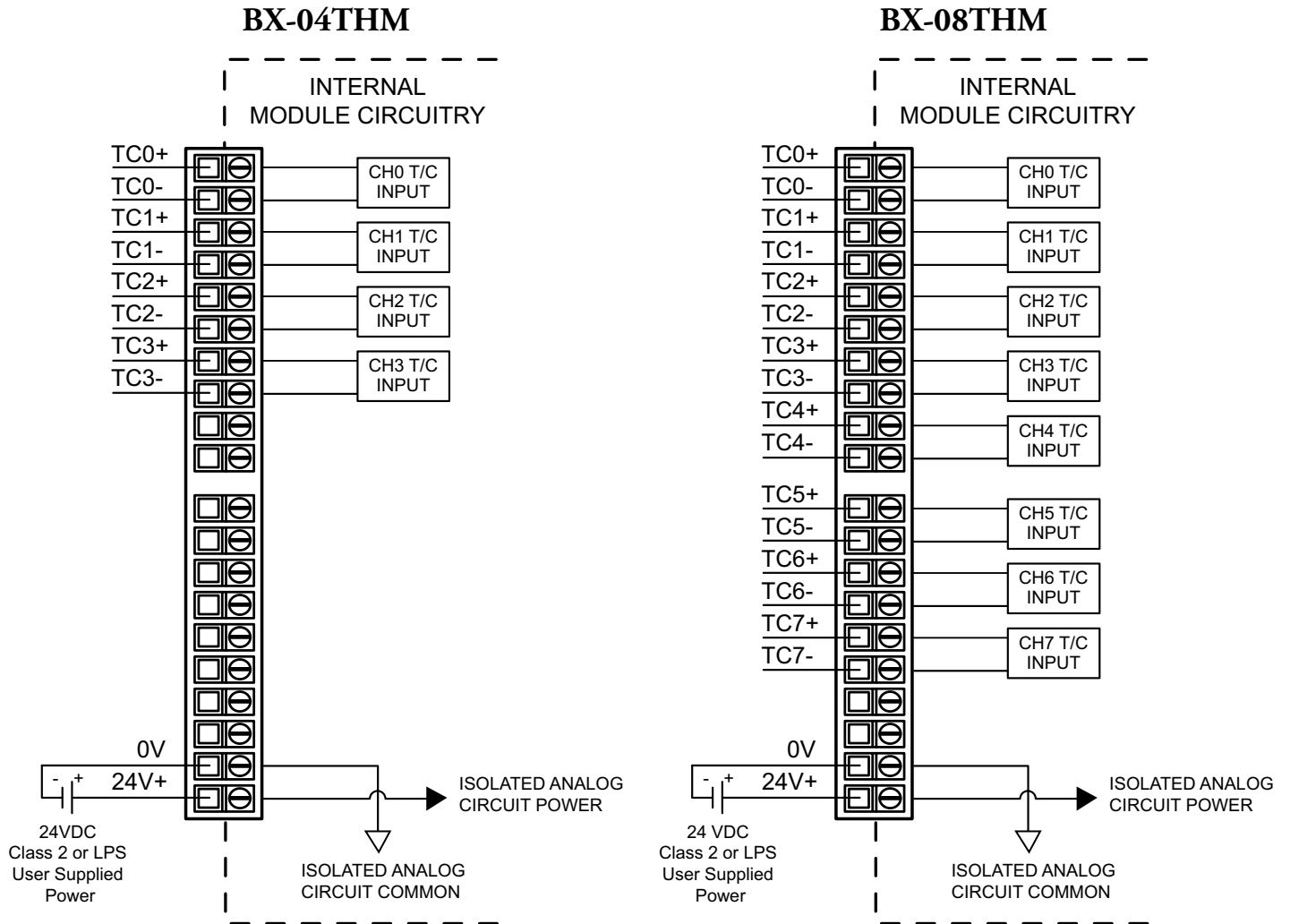

BX-xxTHM Thermocouple Input, continued

Thermocouple Input Circuits

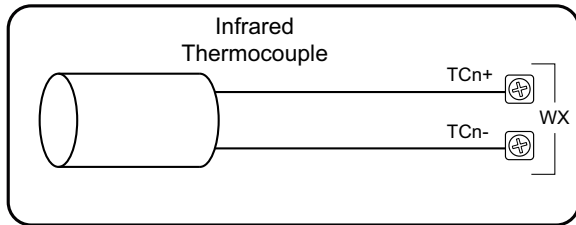
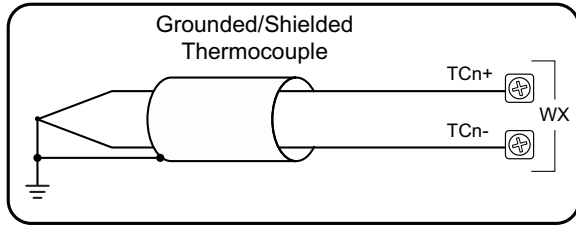
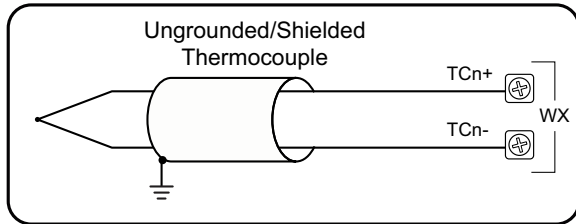

NOTE: Thermocouple extension wire and proper thermocouple terminal blocks must be used to extend thermocouples. AutomationDirect thermocouple wire is recommended.

Analog Voltage Input Circuits

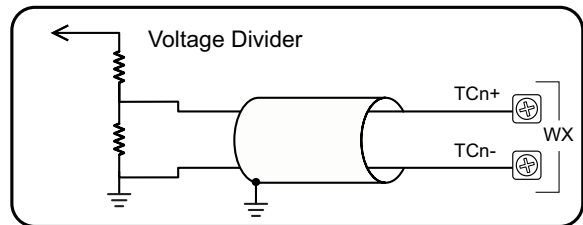
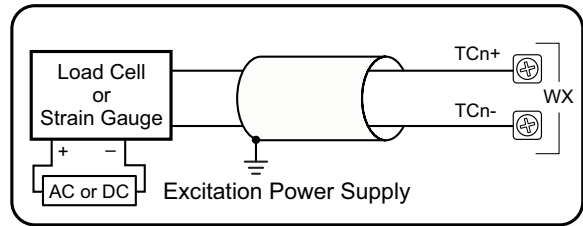
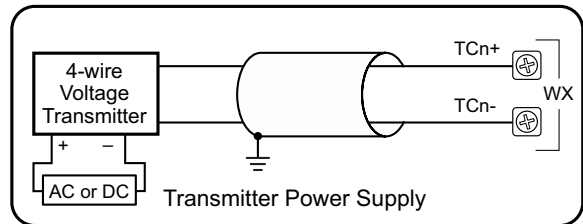

For maximum accuracy, jumper unused inputs. 

NOTE: Shield should be connected only at one end, to ground at the source device.



NOTE: With grounded thermocouples, take precautions to prevent having a voltage potential between thermocouple tips. A voltage of 1.25 V or greater between tips will skew measurements.

BX-xxTHM Thermocouple Input, continued

Software Setup

After the module is installed, open the Do-more! Designer programming software, connect to the BRX MPU and open the **Configure Module** dialog as described at the beginning of this chapter.

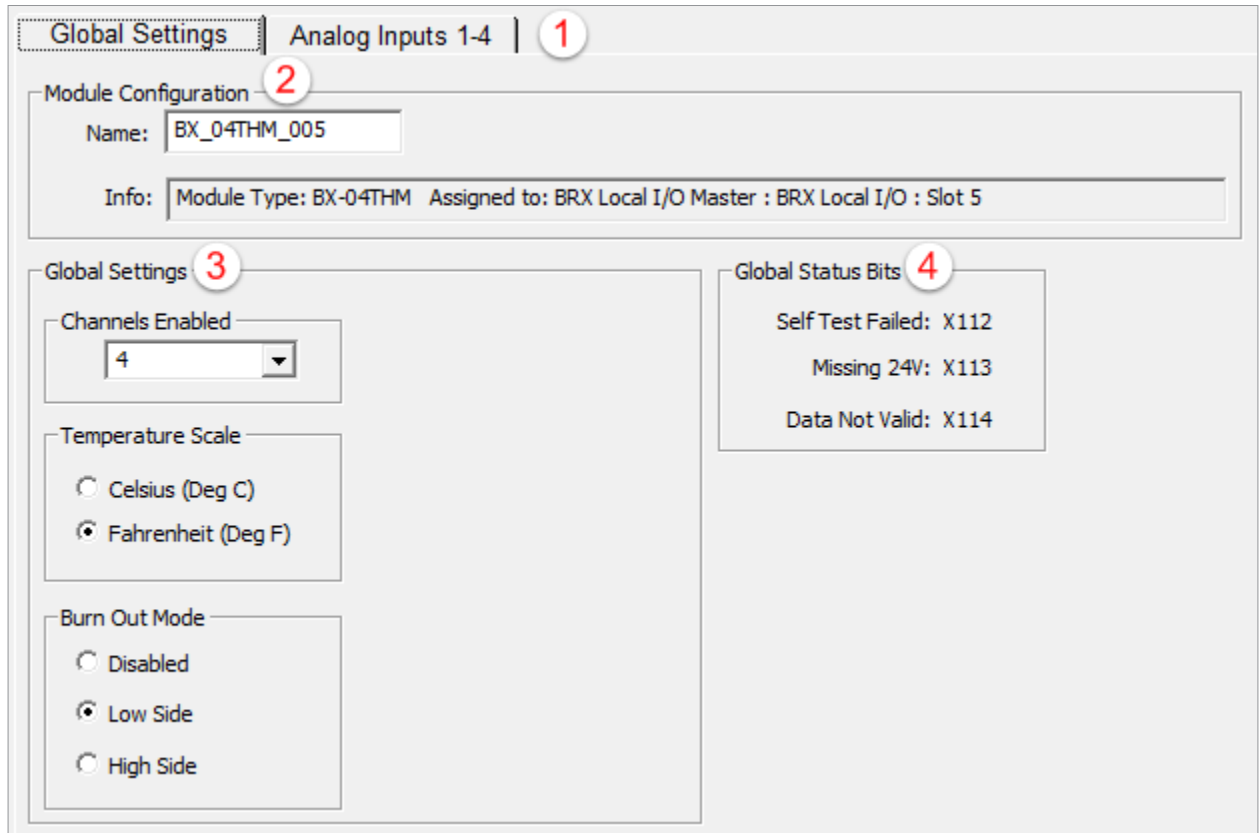

1. The module options are divided into subsets across multiple tabs. Click the appropriate tab to edit the configuration.

2. *Module Configuration*

Name – Each module comes with a default name. This may be changed by the user to better identify the module if desired.

Info – This is the system description of the module. This is static and may not be changed.

3. *Global Settings*

Channels Enabled – Select how many channels will be used. The default is all channels. Selecting fewer channels may increase the update frequency. See the module specifications for details.

Temperature Scale – Select either Celsius or Fahrenheit.

Burn Out Mode – Select if the Input register should read Low or High on burn out or if burn out detection should be disabled. Note: Burn Out Mode must be set to Disabled in order to use a Thermocouple Calibrator.

BX-xxTHM Thermocouple Input, continued

4. Global Status Bits

Self Test Failed – This bit will be On if the module has failed its internal self-test. In this case, the module is likely bad and should be replaced.

Missing 24V – This bit will be on if the external 24VDC power is missing. Check the 24VDC power connection on the module terminal block.

Data Not Valid – This bit will be on if the module does not have the latest configuration parameters or the module has not been configured at all. Reload the program into the CPU and power cycle.

5. Analog Input *x*

These settings are for each channel of the analog module.

Drop-down menu - Select the range of the analog input here.

6. WX x

Range – The number of Raw counts for the selected channel on the module.

Units/Ct – The amount of temperature or voltage that will equal 1 raw count.

Out of Range – The input register that, when On, will indicate that the input is outside of the range selected.

Burn Out – If burn out is enabled, this register will be On when the loop is broken.

7. RX x

Range – The engineering units to which the raw counts are scaled.

Units/Ct – The number of raw counts that will equal 1 scaled engineering unit.

8. Enable Scaling from WX x to RX x

WX x Min – The minimum value of the raw counts to scale.

WX x Max – The maximum value of the raw counts to scale.

RX x Min – The minimum value of the engineering units for scaling.

RX x Max – The maximum value of the engineering units for scaling.

Counts/DegF – Use these buttons to change the raw scaling to counts or degrees (C or F).

Clamp RX x – If this box is checked, RX x will clamp at the minimum and maximum scaled values.

BX-06RTD Resistance Temperature Detector Input

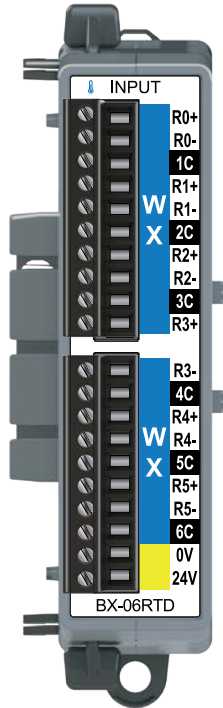

BX-06RTD

Temperature Input
Expansion Module
6-pt RTD
Temperature Input

BX-RTB10 Terminal Blocks Included.
The BX-RTB10-1 or BX-RTB10-2 can
also be used and can be purchased
separately.



NOTE: This device does not support
ZIPLink Wiring Systems.

IMPORTANT!



Hot-Swapping Information

Note: This device cannot be
Hot Swapped.

RTD Input Specifications

Input Channels	6 Differential
Commons	6
Resolution	16-bit, 0.1°C (C or F) (up to 100Hz filter) See Data Range Specifications table
Input Ranges (RTD Types)	Pt100: -200° to 850°C (-328° to 1562°F) (Default) Pt1000: -200° to 595°C (-328° to 1103°F) JPt100: -100° to 450°C (-148° to 842°F) 10Ω Cu: -200° to 260°C (-328° to 500°F) ±3°C 25Ω Cu: -200° to 260°C (-328° to 500°F) ±3°C 120Ω Ni: -80° to 260°C (-112° to 500°F)
Resistance Input Ranges	0 to 10,000 Ω 0 to 6,250 Ω 0 to 3,125 Ω 0 to 1,562.5 Ω 0 to 781.2 Ω 0 to 390.6 Ω 0 to 195.3 Ω
Excitation Current	210μA
RTD Linearization	Automatic
Accuracy vs. Temperature	±10 ppm per °C (maximum)
Full Scale Calibration	±1°C
Offset Calibration Error	±1°C, ±3°C for 10Ω/25Ω Cu.
Maximum Inaccuracy	±1°C, ±3°C for 10Ω/25Ω Cu. maximum (excluding RTD error) (including temperature drift)
Warmup Time	2 minutes for ±0.2% repeatability
All Channel Update Rate	210ms + 170ms x (number of active channels) @470Hz 210ms + 750ms x (number of active channels) @16.7Hz
Filter Characteristics	Digital filter cutoff frequencies: 16.7 Hz, 470Hz
Sample Duration Time	Dependent on digital filter settings: 120ms@16.7 Hz, 4ms@470Hz
Open Circuit Detection Time	Positive full-scale reading within 2s
Maximum Ratings	Fault protected inputs to ±50V
Max. Common Mode Voltage	5VDC
Common Mode Rejection	90dB @ DC and 100dB @ 50/60Hz
Conversion Method	Sigma-Delta
Backplane Power Consumption	0.1 W
External DC Power Required	Class 2 or LPS power supply 24VDC (±20%) 25mA
Heat Dissipation	0.8 W
Weight	96g (3.4 oz)
Agency Approvals	UL 61010-1 and UL 61010-2-201 File E139594, Canada and USA CE (EN 61131-2 EMC, EN 61010-1 and EN 61010-2-201 Safety)
Software Version Required (Do-more! Designer Programming Software)	2.3 or later

BX-06RTD Resistance Temperature Detector Input, continued

Data Range Specifications		
Selection	Description	Raw Counts ¹
Pt100	Pt100 Platinum RTD	°C: -2000 to 8500 °F: -3280 to 15620
Pt1000	Pt1000 Platinum RTD	°C: -2000 to 5950 °F: -3280 to 11030
JPt100	JPt100 Platinum RTD	°C: -1000 to 4500 °F: -1480 to 8420
10Ω Cu	10Ω Copper RTD	°C: -2000 to 2600 °F: -3280 to 5000
25Ω Cu	25Ω Copper RTD	°C: -2000 to 2600 °F: -3280 to 5000
120Ω Ni	120Ω Nickel RTD	°C: -800 to 2600 °F: -1120 to 5000
0-10,000 Ω		0-10000
0-6,250 Ω		0-6250
0-3,125 Ω		0-3125
0-1,562.5 Ω		0-15625 ²
0-781.2 Ω		0-7812 ²
0-390.6 Ω		0-3906 ²
0-195.3 Ω		0-1953 ²

1. Temperatures have one implied decimal place (e.g., raw count of -1900 is -190.0°).
2. Certain resistance ranges have one implied decimal place (e.g., raw count of 7812 is 781.2 Ω).

The module reserves the first 24 bits of unused contiguous space in the X register, aligned to an 8-bit word boundary, for status reporting. Error flags for this module are laid out within its status register space as described in the table below.

Error Flag Specifications								
	MSB							LSB
1st Byte of unused X Registers								
Module Status	-	-	-	-	-	Data Not Valid	Missing 24VDC	Self Test Failed
2nd Byte of unused X Registers								
Channel Out of Range	-	-	Channel 6	Channel 5	Channel 4	Channel 3	Channel 2	Channel 1
3rd Byte of unused X Registers								
Burn Out	-	-	Channel 6	Channel 5	Channel 4	Channel 3	Channel 2	Channel 1



NOTE: The Data Not Valid flag should always be tested and confirmed to be in the "Off" state in your PLC program before reading from the analog module.

BX-06RTD Resistance Temperature Detector Input, continued

Analog RTD/Resistance Input Wiring

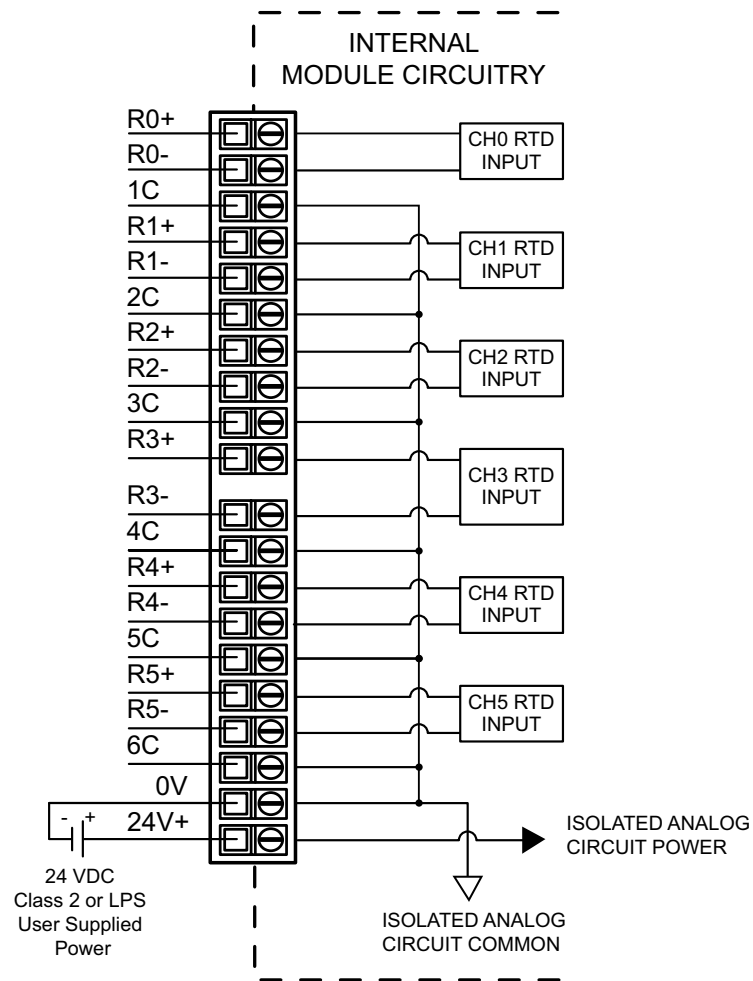

BX-06RTD Resistance Temperature Detector Input, continued

RTD Input Circuits

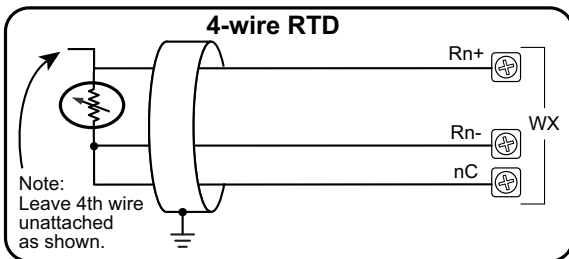
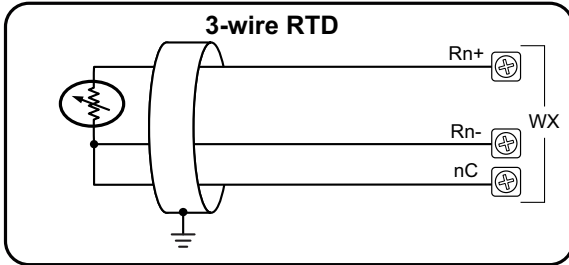
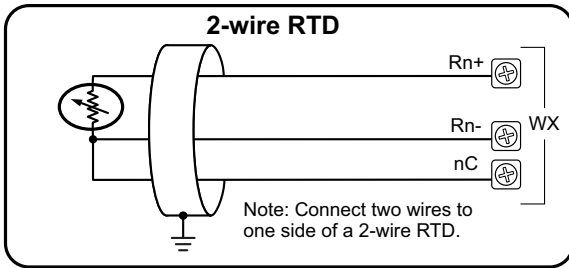

Resistance Input

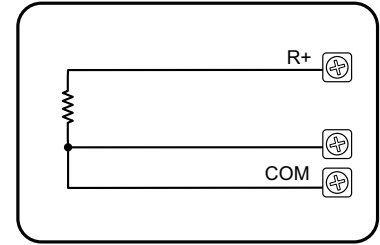

Notes for maximum accuracy:

1. For 2-wire RTD, attach a third wire to module common.
2. R+, R-, and COM wires to an RTD must be equal length and type. Refer to RTD manufacturer's recommendations.
3. Do not use cable shield as sensing wire.
4. When applicable, connect shield to RTD common only, otherwise connect to module common only. Do not connect shield to both ends.
5. Jumper unused inputs to common.

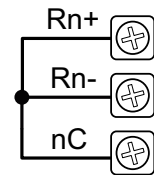

BX-06RTD Resistance Temperature Detector Input, continued

Software Setup

After the module is installed, open the Do-more! Designer programming software version 2.3 or later, connect to the BRX MPU and open the **Configure Module** dialog as described at the beginning of this chapter.

The screenshot shows the 'Configure Module' dialog for a BX-06RTD module. The dialog is divided into four tabs: 'Global Settings', 'Analog Inputs 1-4', 'Analog Inputs 5-6', and 'Global Status Bits'. The 'Global Settings' tab is selected and contains the following configuration options:

- Module Configuration:**
 - Name: BX_06RTD_001
 - Info: Module Type: BX-06RTD Assigned to: BRX Local I/O Master : BRX Local I/O : Slot 1
- Global Settings:**
 - Channels Enabled: 6
 - Channel Range: Pt100
 - Temperature Scale: Fahrenheit (Deg F)
 - Conversion Rate/Accuracy: 16Hz/16 Bit/125ms
 - Burn Out Mode: Low Side
- Global Status Bits:**
 - Self Test Failed: X8
 - Missing 24V: X9
 - Data Not Valid: X10

1. The module options are divided into subsets across multiple tabs. Click the appropriate tab to edit the configuration.
2. *Module Configuration*
 - Name* – Each module comes with a default name. This may be changed by the user to better identify the module, if desired.
 - Info* – This is the system description of the module. This is static and may not be changed.
3. *Global Settings*
 - Channels Enabled* – Select how many channels will be used. The default is all channels. Selecting fewer channels may increase the update frequency. See the module specifications for details.
 - Temperature Scale* – Select either Celsius or Fahrenheit.
 - Burn Out Mode* – Select if the Input register should read Low or High on burn out or if burn out detection should be disabled.
 - Channel Range* – Select the RTD type or resistance range to measure. Note this setting affects all channels in the module.
 - Conversion Rate/Accuracy* – Select the desired sample conversion rate and accuracy.

BX-06RTD Resistance Temperature Detector Input, continued

4. Global Status Bits

Self Test Failed – This bit will be On if the module has failed its internal self-test. In this case, the module is likely bad and should be replaced.

Missing 24V – This bit will be on if the external 24VDC power is missing. Check the 24VDC power connection on the module terminal block.

Data Not Valid – This bit will be on if the module does not have the latest configuration parameters or the module has not been configured at all. Reload the program into the CPU and power cycle.

The screenshot shows the configuration window for Analog Input 1. It is divided into three main sections:

- Analog Input 1 (5):** A dropdown menu is set to 'Pt100'.
- WX1 (6):**
 - Range: -32768 - 32767 (16 bits)
 - Units/Ct: 0.1DegF
 - Out of Range: X16
 - Burn Out: X24
- RX1 (7):**
 - Range: 0.00 - 100.00
 - Units/Ct: 0.001526

On the right side, there is a section for scaling:

- Enable Scaling from WX1 to RX1 (8):** A checked checkbox.
- WX1 Min:** -32768
- WX1 Max:** 32767
- RX1 Min:** 0
- RX1 Max:** 100
- Buttons:** 'Counts' and 'DegF' (the 'DegF' button is selected).
- Clamp RX1:** An unchecked checkbox.

5. Analog Input *x*

Input type for this module is a per-module setting. The settings are shown here for information only.

6. *WXx*

Range – The number of Raw counts for the selected channel on the module.

Units/Ct – The amount of temperature or voltage that will equal 1 raw count.

Out of Range – The input register that, when On, will indicate that the input is outside of the range selected.

Burn Out – If burn out is enabled, this register will be On when the loop is broken.

7. *RXx*

Range – The engineering units to which the raw counts are scaled.

Units/Ct – The number of raw counts that will equal 1 scaled engineering unit.

8. *Enable Scaling from WXx to RXx*

WXx Min – The minimum value of the raw counts to scale.

WXx Max – The maximum value of the raw counts to scale.

RXx Min – The minimum value of the engineering units for scaling.

RXx Max – The maximum value of the engineering units for scaling.

Counts/DegF – Use these buttons to change the raw scaling to counts or degrees (C or F).

Clamp RXx – If this box is checked, RXx will clamp at the minimum and maximum scaled values.

BX-08NTC Thermistor Input

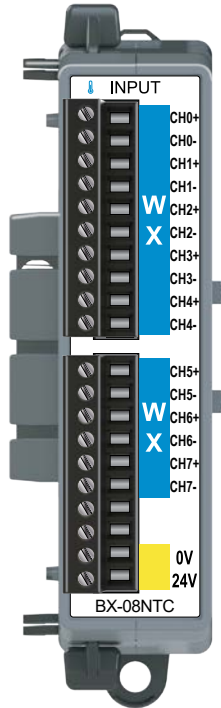

BX-08NTC

Temperature Input
Expansion Module
8-pt Thermistor
Temperature Input

BX-RTB10 Terminal Blocks Included.
The BX-RTB10-1 or BX-RTB10-2 can
also be used and can be purchased
separately.



NOTE: This device does not support
ZIPLink Wiring Systems.

Thermistor Input Specifications	
Input Channels	8 Single-ended
Commons	0
Resolution	16-bit, $\pm 0.1^\circ\text{C}$ or $^\circ\text{F}$ (up to 100Hz filter) See Data Range Specifications table
Thermistor Input Ranges	2252: -40° to 150°C (-40° to 302°F) 10K-AN Type 3: -40° to 150°C (-40° to 302°F) 10K-CP Type 2: -40° to 150°C (-40° to 302°F) 5K: -40° to 150°C (-40° to 302°F) 3K: -40° to 150°C (-40° to 302°F) 1.8K: -40° to 150°C (-40° to 302°F)
Thermistor Linearization	Automatic
Excitation Current (all ranges)	10 μA to 210 μA autoscaling
Accuracy vs. Temperature	$\pm 10\text{PPM}$ per $^\circ\text{C}$ (maximum)
Full Scale Calibration	$\pm 1^\circ\text{C}$
Offset Calibration Error	$\pm 1^\circ\text{C}$
Linearity Error (end to end)	Nonlinear
Maximum Inaccuracy	1 $^\circ\text{C}$ @ 16.7 Hz, 2.5 $^\circ\text{C}$ @ 470Hz
Warm-up Time	30 minutes for $\pm 1^\circ\text{C}$ Repeatability
Sample Duration	120ms @ 16.7 Hz, 4ms @ 470Hz
All Channel Update Rate	2.2 s @ 16.7 Hz
Open Circuit Detection Time	Within 2s @ 16.7 Hz
Common Mode Rejection	100dB @ DC and 100dB @ 60Hz
Absolute Maximum Ratings	Fault protected inputs to $\pm 50\text{V}$
Conversion Method	Sigma-Delta
Backplane Power Consumption	0.1 W
External DC Power Required	Class 2 or LPS power supply 24VDC ($\pm 20\%$) 25mA
Heat Dissipation	0.8 W
Weight	98g (3.5 oz)
Agency Approvals	UL 61010-1 and UL 61010-2-201 File E139594, Canada and USA CE (EN 61131-2 EMC, EN 61010-1 and EN 61010-2-201 Safety)
Software Version Required (Do-more! Designer Programming Software)	2.3 or later

IMPORTANT!



Hot-Swapping Information

Note: This device cannot be Hot Swapped.

BX-08NTC Thermistor Input, continued

Data Range Specifications		
Selection	Description	Raw Counts ¹
2252	2252Ω thermistor	°C: -400 to 1500 °F: -400 to 3020
10K-AN Type 3	10kΩ Type 3 (AN) thermistor	
10K-CP Type 2	10kΩ Type 2 (CP) thermistor	
5K	5kΩ thermistor	
3K	3kΩ thermistor	
1.8K	1.8 kΩ thermistor	

1. Temperatures have one implied decimal place (e.g., raw count of -400 is -40.0°).

The module reserves the first 24 bits of unused contiguous space in the X register, aligned to an 8-bit word boundary, for status reporting. Error flags for this module are laid out within its status register space as described in the table below.

Error Flag Specifications								
	MSB							LSB
1st Byte of unused X Registers								
Module Status	-	-	-	-	-	Data Not Valid	Missing 24VDC	Self Test Failed
2nd Byte of unused X Registers								
Channel Out of Range	Channel 8	Channel 7	Channel 6	Channel 5	Channel 4	Channel 3	Channel 2	Channel 1
3rd Byte of unused X Registers								
Burn Out	Channel 8	Channel 7	Channel 6	Channel 5	Channel 4	Channel 3	Channel 2	Channel 1



NOTE: The Data Not Valid flag should always be tested and confirmed to be in the "Off" state in your PLC program before reading from the analog module.

BX-08NTC Thermistor Input, continued

Analog Thermistor Input Wiring

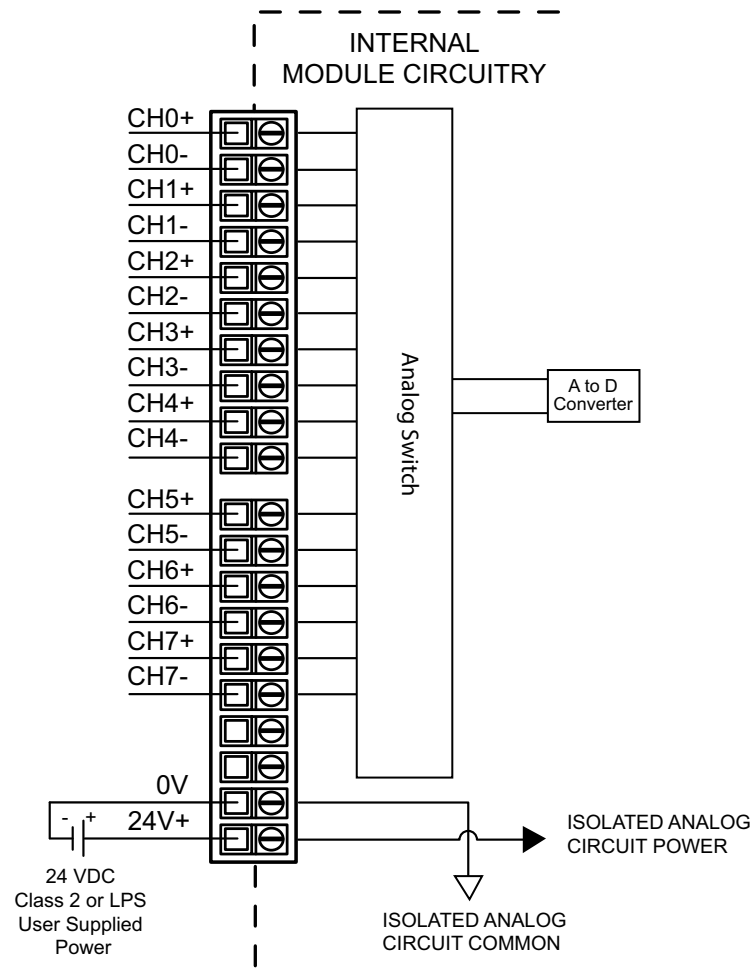

Thermistor Input

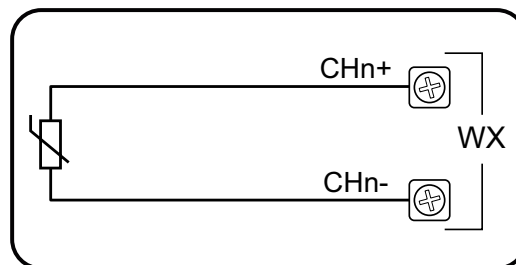

BX-08NTC Thermistor Input, continued

Software Setup

After the module is installed, open the Do-more! Designer programming software version 2.3 or later, connect to the BRX MPU and open the **Configure Module** dialog as described at the beginning of this chapter.

1. The module options are divided into subsets across multiple tabs. Click the appropriate tab to edit the configuration.
2. *Module Configuration*
Name – Each module comes with a default name. This may be changed by the user to better identify the module if desired.
Info – This is the system description of the module. This is static and may not be changed.
3. *Global Settings*
Channels Enabled – Select how many channels will be used. The default is all channels. Selecting fewer channels may increase the update frequency. See the module specifications for details.
Temperature Scale – Select either Celsius or Fahrenheit.
Burn Out Mode – Select if the Input register should read Low or High on burn out or if burn out detection should be disabled.
Channel Range – Select the RTD type or resistance range to measure. Note this setting affects all channels in the module.
Conversion Rate/Accuracy – Select the desired sample conversion rate and accuracy.

BX-08NTC Thermistor Input, continued

4. Global Status Bits

Self Test Failed – This bit will be On if the module has failed its internal self-test. In this case, the module is likely bad and should be replaced.

Missing 24V – This bit will be on if the external 24VDC power is missing. Check the 24VDC power connection on the module terminal block.

Data Not Valid – This bit will be on if the module does not have the latest configuration parameters or the module has not been configured at all. Reload the program into the CPU and power cycle.

5. Analog Input *x*

Input type for this module is a per-module setting. The settings are shown here for information only.

6. *WXx*

Range – The number of Raw counts for the selected channel on the module.

Units/Ct – The amount of temperature change that will equal 1 raw count.

Out of Range – The input register that, when On, will indicate that the input is outside of the range selected.

Burn Out – If burn out is enabled, this register will be On when the loop is broken.

7. *RXx*

Range – The engineering units to which the raw counts are scaled.

Units/Ct – The number of raw counts that will equal 1 scaled engineering unit.

8. *Enable Scaling from WXx to RXx*

WXx Min – The minimum value of the raw counts to scale.

WXx Max – The maximum value of the raw counts to scale.

RXx Min – The minimum value of the engineering units for scaling.

RXx Max – The maximum value of the engineering units for scaling.

Counts/DegF – Use these buttons to change the raw scaling to counts or degrees (C or F).

Clamp RXx – If this box is checked, *RXx* will clamp at the minimum and maximum scaled values.

BX-xxUT Universal Temperature Input

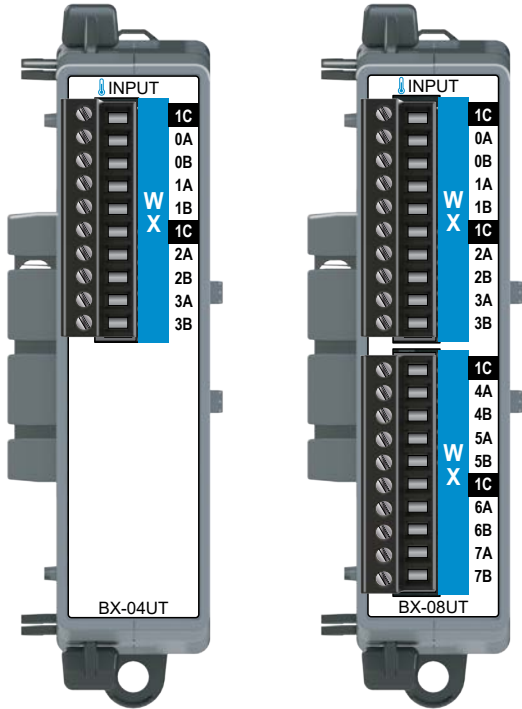

BX-04UT
Temperature Input Expansion Module
4-pt Universal Temperature Input

BX-08UT
Temperature Input Expansion Module
8-pt Universal Temperature Input

BX-RTB10 Terminal Blocks Included.
The BX-RTB10-1 or BX-RTB10-2 can also be used and can be purchased separately.



NOTE: This device does not support ZIPLink Wiring Systems.

Universal Temperature Input Specifications		
	BX-04UT	BX-08UT
Input Channels	4 Differential	8 Differential
Commons	1	
Input Impedance	>5MΩ	
Resolution	24-bit, 0.1°(C or F) See Data Range Spec. table	
All Channel Update Rate (Max with noted inputs enabled)	1s (4 thermocouples) 700ms (4RTD/NTX/mV)	2s (8 thermocouples) 1.4s (4RTD/NTX/mV)
Sample Duration Time	175ms	
Open Circuit Detection Time	Within 5s	
Maximum Ratings	-0.3 V to +5.3 V, <15mA	
Common Mode Range	-0.3 V to +5.3 V	
Common Mode Rejection	100dB@DC, 130dB@60Hz	
Conversion Method	Sigma-Delta, 24-bit	
Backplane Power Consumption	1.5 W	
Heat Dissipation	1.5 W	
Weight	98g (3.5 oz)	
Agency Approvals	UL 61010-2 File E185989, Canada and USA	
Software Version Required	Do-more! Designer 2.7 or later	
Thermocouple Parameters		
Thermocouple Input Ranges	Type J: -210° to 1200°C (-346° to 2192°F) Type K: -265° to 1372°C (-445° to 2502°F) Type E: -265° to 1000°C (-445° to 1832°F) Type N: -265° to 1300°C (-445° to 2372°F) Type R: -50° to 1768°C (-58° to 3214°F) Type S: -50° to 1768°C (-58° to 3214°F) Type B: 40° to 1820°C (104° to 3308°F) Type T: -265° to 400°C (-445° to 752°F)	
Linear Voltage Input Ranges	-31.25 to 31.25 mVDC -31.25 to 62.5 mVDC	-31.25 to 125mVDC 0 to 1.0 VDC
Cold Junction Compensation	Automatic	
Thermocouple Linearization	Automatic	
Max. Inaccuracy–Thermocouple	±(0.2°C + 3% of °C reading)	
Maximum Inaccuracy–Voltage	±250µV	
RTD/Thermistor Parameters		
RTD Input Ranges (RTD Types)	10, 50, 100, 200, 500, 1000Ω Pt Platinum RTD 0.00385 European Curve: -200° to 850°C (-328° to 1562°F) 120Ω Ni N120 Nickel RTD 0.00672 Curve: -80° to 260°C (-112° to 500°F)	
Thermistor Input Ranges	2.252 kΩ @ 25°C: -40° to 150°C (-40° to 302°F) 3 kΩ @ 25°C: -40° to 150°C (-40° to 302°F) 5 kΩ @ 25°C: -40° to 150°C (-40° to 302°F) 10k-AN Type 3 @ 25°C: -40° to 150°C (-40° to 302°F) 30 kΩ @ 25°C: -40° to 150°C (-40° to 302°F)	
RTD Excitation Current	RTD 10, 100, 120, 200:	1mA
	RTD 500:	500µA
	RTD 1000:	250µA
Thermistor Excitation Current	NTC 2.252k, NTC 3k:	10µA
	NTC 5k, NTC 10k:	5µA
	NTC 30k:	1µA
Thermistor Linearization	Automatic	
Maximum Inaccuracy	±0.2°C	

IMPORTANT!



Hot-Swapping Information
Note: This device cannot be Hot Swapped.

BX-xxUT Universal Temperature Input, continued

Data Range Specifications			
Thermocouple Selection	Temperature Range	Resolution	
		WXn	RXn
Type J	-210 to 1200 °C -346 to 2192 °F	Degrees x10 (One Implied Decimal) ¹	24-Bit Floating ¹
Type K	-265 to 1372 °C -445 to 2502 °F		
Type E	-265 to 1000 °C -445 to 1832 °F		
Type R	-50 to 1768 °C -58 to 3214 °F		
Type S	-50 to 1768 °C -58 to 3214 °F		
Type B	40 to 1820 °C 104 to 3308 °F ³		
Type T	-265 to 400 °C -445 to 752 °F		
Voltage Selection	Voltage Range	WXn ²	RXn
-31.25 to 31.25 mVDC	Bipolar 31.25 mVDC	0.95 µV per count (-32768 to 32767)	User Scaled
-31.25 to 62.5 mVDC	Bipolar 62.5 mVDC	1.9 µV per count (-16384 to 32767)	
-31.25 to 125 mVDC	Bipolar 125 mVDC	3.8 µV per count (-8192 to 32767)	
0 to 1.0 VDC	Unipolar 1.0 VDC	30.5 µV per count (0 to 32767)	
RTD Selection	Temperature Range	WXn	RXn
10, 50, 100, 200, 500, 1000Ω Pt Platinum RTD 0.00385 European Curve	-200 to 850 °C -328 to 1562 °F	Degrees x10 (One Implied Decimal) ¹	24-Bit Floating ¹
120Ω Ni N120 Nickel RTD 0.00672 Curve	-80 to 260 °C -112 to 500 °F		
Thermistor Selection	Temperature Range	WXn	RXn
Thermistor 2.252 kΩ @25°C	-40 to 150 °C -40 to 302 °F	Degrees x10 (One Implied Decimal) ¹	24-Bit Floating ¹
Thermistor 3kΩ @25°C			
Thermistor 5kΩ @25°C			
Thermistor 10k-AN Type 3 @25°C			
Thermistor 30kΩ @25°C			

1. Temperatures reported in rounded integer to WXn and as scaled floating point 24bits resolution to RXn.

2. Raw Counts = -32768 to 32767.

3. Max value displayed in WXn is 32767. RXn will display the full range of 3308.0.

The module reserves the first 16 bits of unused contiguous space in the X register, aligned to an 8-bit word boundary, for status reporting. Error flags for this module are laid out within its status register space as described in the table below.

Error Flag Specifications								
	MSB							LSB
1st Byte of unused X Registers								
Module Status	Channel 4 Burnout	Channel 4 Out of Range	Channel 3 Burnout	Channel 3 Out of Range	Channel 2 Burnout	Channel 2 Out of Range	Channel 1 Burnout	Channel 1 Out of Range
2nd Byte of unused X Registers								
Module Status	Channel 8 Burnout	Channel 8 Out of Range	Channel 7 Burnout	Channel 7 Out of Range	Channel 6 Burnout	Channel 6 Out of Range	Channel 5 Burnout	Channel 5 Out of Range

BX-xxUT Universal Temperature Input, continued

Analog Thermocouple/Voltage Input Wiring

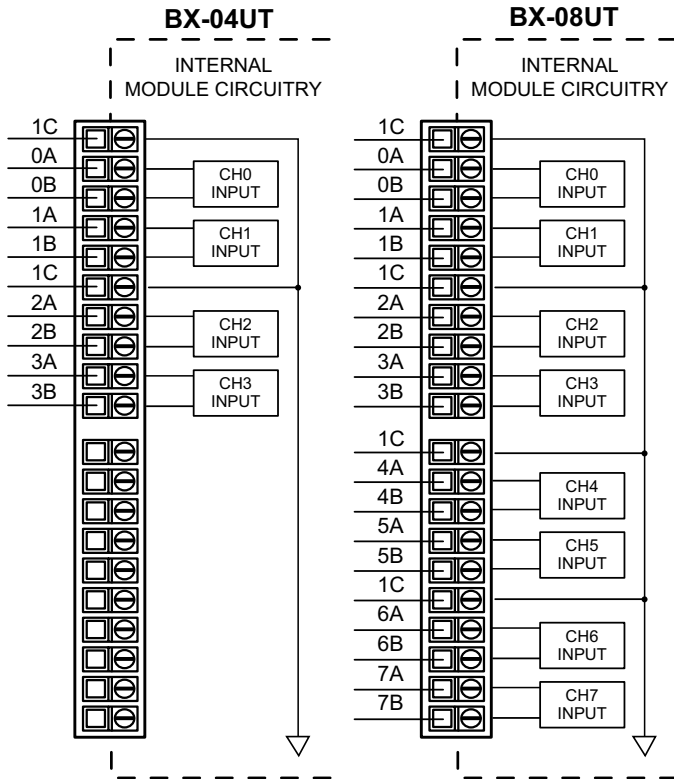

Mixed Resistive and Thermocouple Sensors

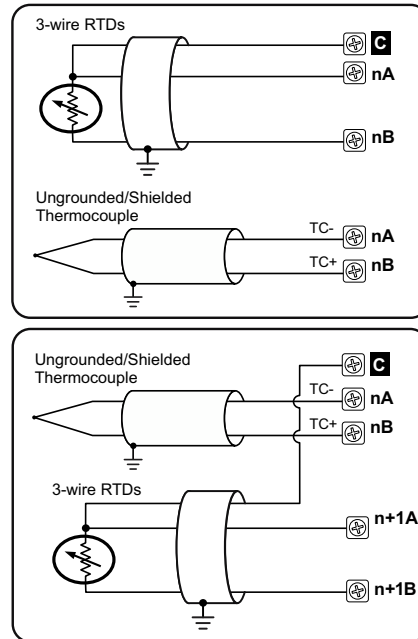

Notes for maximum accuracy:

1. All wires to an RTD must be equal length and type. Refer to RTD manufacturer's recommendations.
2. Do not use cable shield as sensing wire.
3. When applicable, connect shield to RTD common only, otherwise connect to module common only. Do not connect shield to both ends.
4. Jumper unused inputs.



BX-xxUT Universal Temperature Input, continued

Thermocouple and Voltage Sensors

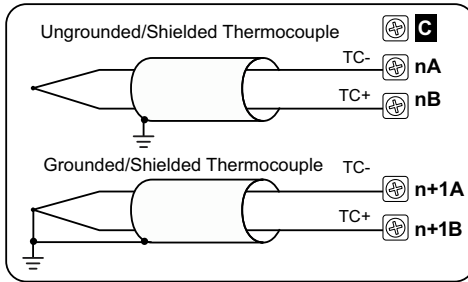

NOTE: Thermocouple extension wire and proper thermocouple terminal blocks must be used to extend thermocouples. AutomationDirect thermocouple wire is recommended.

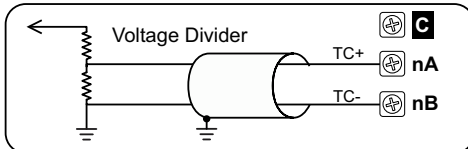
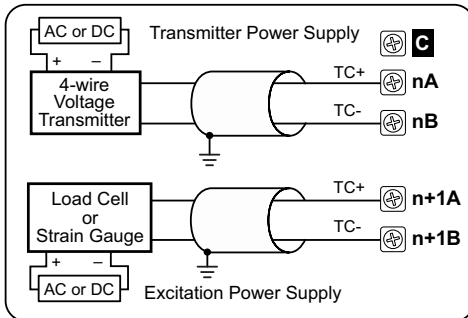

NOTE: Shield should be connected only at one end, to ground at the source device.

For maximum accuracy:
 Jumper unused inputs.
 TC+ **C**
 TC- **C**

Resistive and Thermistor Sensors

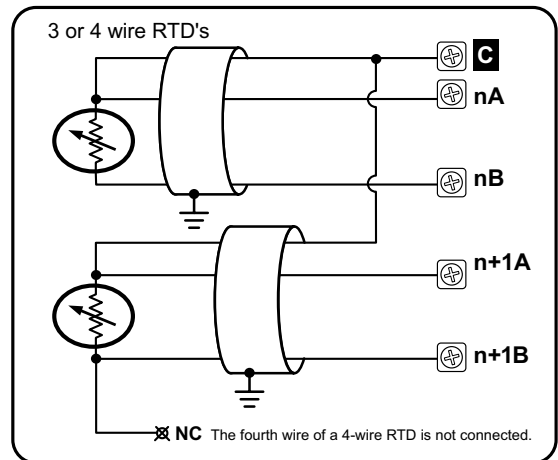
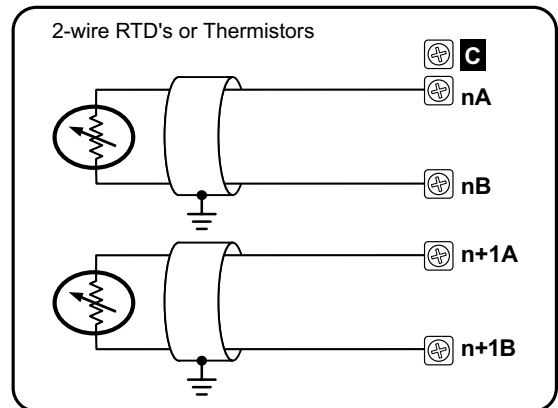

NOTE: With grounded thermocouples, take precautions to prevent having a voltage potential between thermocouple tips. A voltage of 1.25 V or greater between tips will skew measurements.

BX-xxUT Universal Temperature Input, continued

Software Setup

After the module is installed, open the Do-more! Designer programming software, connect to the BRX MPU and open the **Configure Module** dialog as described at the beginning of this chapter.

Setup BX-08UT Module

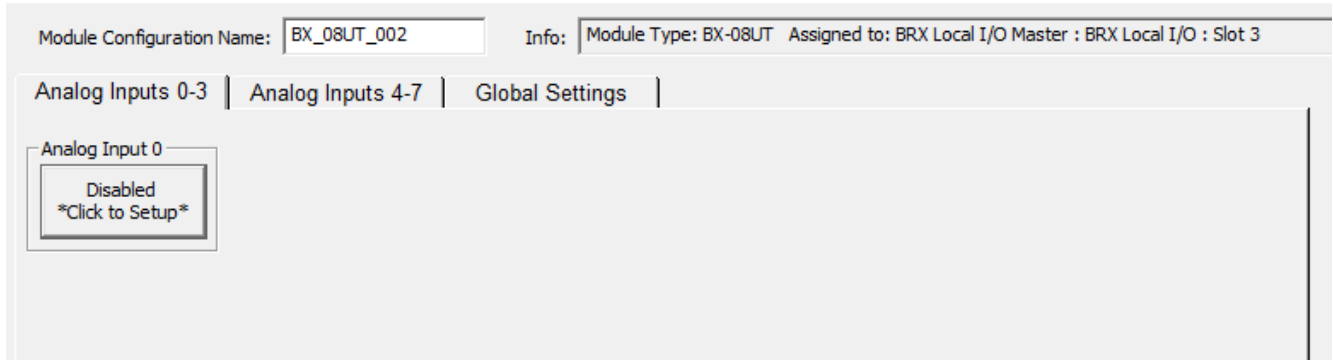

1. *Analog Input x*

Button – Click the button to set up the channel.

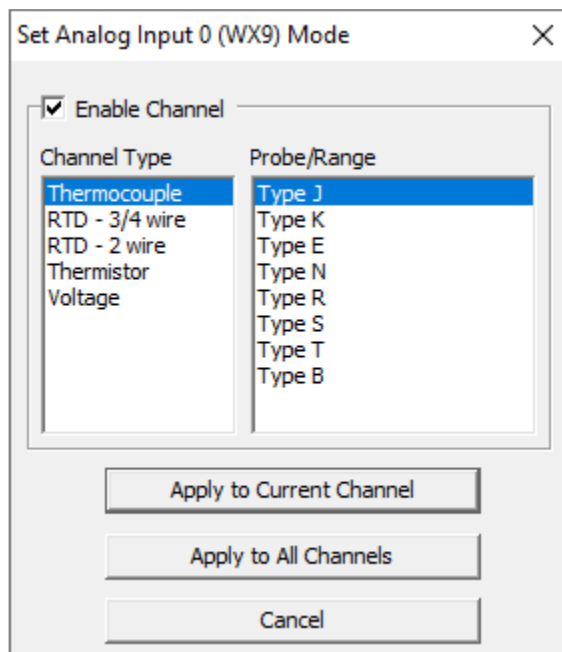

2. Set *Analog Input x*

Enable Channel – Check the box to enable this channel.

Channel Type – Select the type of device for this channel. This can be different for each channel.

Probe/Range – Select the style of device for this channel.

Apply to Current Channel – Apply these settings to just this one channel.

Apply to All Channels – Apply these settings to every channel on the card.

Cancel – Make no changes and leave this dialog.

BX-xxUT Universal Temperature Input, continued

Setup BX-08UT Module

Module Configuration Name: Info:

Analog Inputs 0-3 | Analog Inputs 4-7 | Global Settings

Analog Input 0

Thermocouple Type J

Filter Time:
Time is in seconds. Enter 0 to disable.

WX9
Range: -346 - 2192
Units/Ct: 1DegF
Out of Range: X24
Burn Out: X25

RX9
Range: -346.00 - 2192.00

3. *WXx*

Range – The temperature in whole degrees for the selected channel on the module.

Units/Ct – The amount of temperature change that will equal 1 raw count.

Out of Range – The input register that, when On, will indicate that the input is outside of the range selected.

Burn Out – If burn out is enabled, this register will be On when the loop is broken.

4. *RXx*

Range – The floating point value of the channel temperature.

Setup BX-08UT Module

Module Configuration Name: Info:

Analog Inputs 0-3 | Analog Inputs 4-7 | Global Settings

Global Settings

Temperature Scale

Fahrenheit (Deg F)
 Celsius (Deg C)

A/C Rejection

50/60Hz @75dB
 60Hz @120dB
 50Hz @120dB

5. *Temperature Scale*

Select Fahrenheit or Celsius.

6. *A/C Rejection*

The rejection range for the common mode rejection. This is typically set to the AC line frequency at the installation.

BX-xxDA-1 Analog Current Source Output

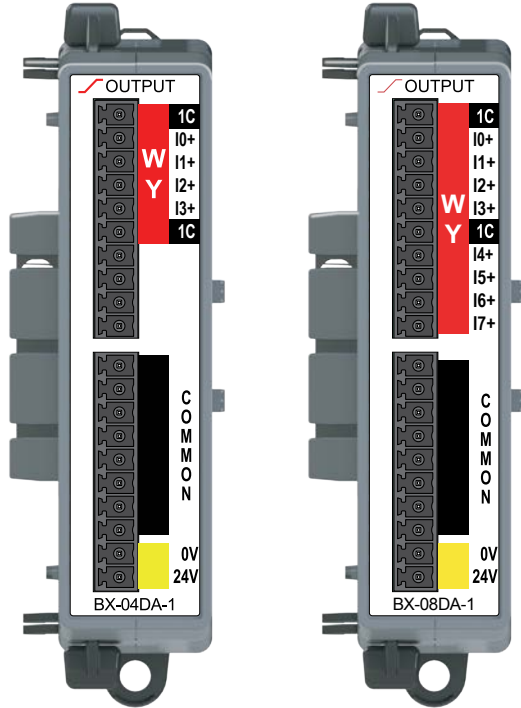

BX-04DA-1

Analog Output Expansion Module
4-ch, 0-20mA/4-20mA, 16-bit

BX-08DA-1

Analog Output Expansion Module
8-ch, 0-20mA/4-20mA, 16-bit

Terminal Blocks or ZIPLink Cables Sold Separately



We recommend using prewired ZIPLink cables and connection modules. If you wish to hand-wire your module, a removable terminal block is available. See Wiring Termination Selection in this chapter for all options.

Analog Current Source Output Specifications		
	BX-04DA-1	BX-08DA-1
Outputs per Module	4	8
Commons	1	
Module Signal Output Range	0–20mA, 4–20mA (Default)	
Signal Resolution	16-bit, 15-bit (Default)	
Resolution Value of LSB	See Data Range Specifications table	
Output Type	Current Sourcing up to 22mA	
Output Value in Fault Mode	~0mA	
Maximum Load Impedance	700Ω	
Maximum Capacitive Load	1000pF	
Allowed Load Type	Grounded	
Maximum Continuous Overload	30mA	
All Channel Update Rate	1.5 ms per enabled channel	
Maximum Inaccuracy	±0.1% of range	±0.05% of range
Maximum Full Scale Calibration Error	±0.05% of range	
Maximum Offset Calibration Error	±0.05% of range	
Conversion Method	Successive approximation	
Accuracy vs. Temperature	±25PPM / °C maximum	
Maximum Crosstalk	+10μV	
Linearity Error (end to end)	±0.08% of range	±0.06% of range
Output Stability and Repeatability	±0.02% of full range after 10 minute warmup (typical)	
Output Ripple	±0.01% of range/mA	
Output Settling Time	200μs	
Channel to Backplane Isolation	1800VAC applied for one second	
Channel to Channel Isolation	None	
Loop Fusing (External)	Fast-acting 0.032A recommended	
Backplane Power Consumption	0.1 W	
External DC Power Required	Class 2 or LPS power supply 24VDC (±20%)	
	175mA	250mA
Heat Dissipation	5.1 W	8.1 W
Weight	98g (3.5 oz)	
Agency Approvals	UL 61010-1 and UL 61010-2-201 File E139594, Canada and USA CE (EN 61131-2 EMC, EN 61010-1 and EN 61010-2-201 Safety)	
Software Version Required (Do-more! Designer Programming Software)	2.3 or later	2.1 or later

IMPORTANT!



Hot-Swapping Information

Note: This device cannot be Hot Swapped.

BX-xxDA-1 Analog Current Source Output, continued

Data Range Specifications							
Selection	Description	Enable 16 bit Unchecked (15 bit Resolution, Default)			Enable 16 bit Checked (16 bit Resolution)		
		Raw Counts	Casting*	µA Per Count	Raw Counts	Casting*	µA Per Count
0–20mA	unipolar 0–20mA	0–32767	-	0.61	0–65535	WYn:U	0.31
4–20mA	unipolar 4–20mA	0–32767	-	0.49	0–65535	WYn:U	0.24

* For more information on Casting, refer to Help topic DMD0309 in the Do-more! Designer Software.

The module reserves the first 24 bits of unused contiguous space in the X register, aligned to an 8-bit word boundary, for status reporting. Error flags for this module are laid out within its status register space as described in the table below.

Error Flag Specifications								
	MSB							LSB
1st Byte of unused X Registers								
Module Status	-	-	-	-	-	Data Not Valid	Missing 24VDC	Self Test Failed
2nd Byte of unused X Registers								
Unused	-	-	-	-	-	-	-	-
3rd Byte of unused X Registers								
Unused	-	-	-	-	-	-	-	-



NOTE: The Data Not Valid flag should always be tested and confirmed to be in the "Off" state in your PLC program before writing to the analog module.

BX-xxDA-1 Analog Current Source Output, continued

Analog Current Output Wiring

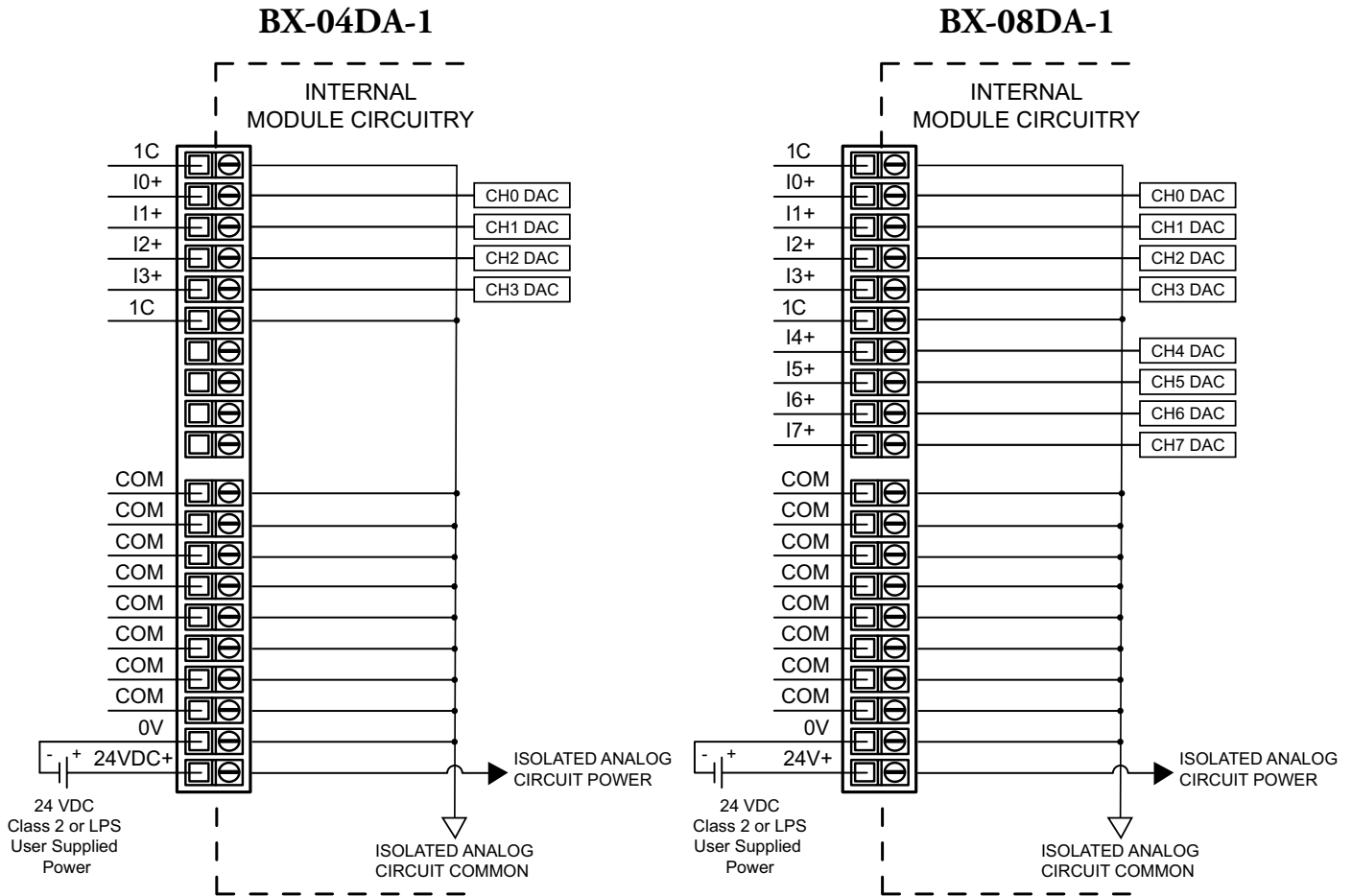

Analog Current Source Output

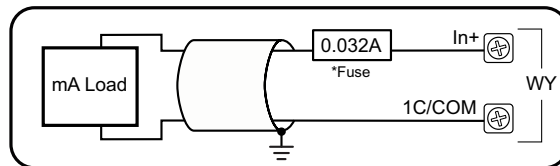

*An Edison S500-32-R 0.032A fast-acting fuse is recommended for all analog voltage inputs, analog outputs, and current loops.

NOTE: Shield should be connected only at one end, to ground at the source device.

BX-xxDA-1 Analog Current Source Output, continued

Software Setup

After the module is installed, open the Do-more! Designer programming software, connect to the BRX MPU and open the **Configure Module** dialog as described at the beginning of this chapter.

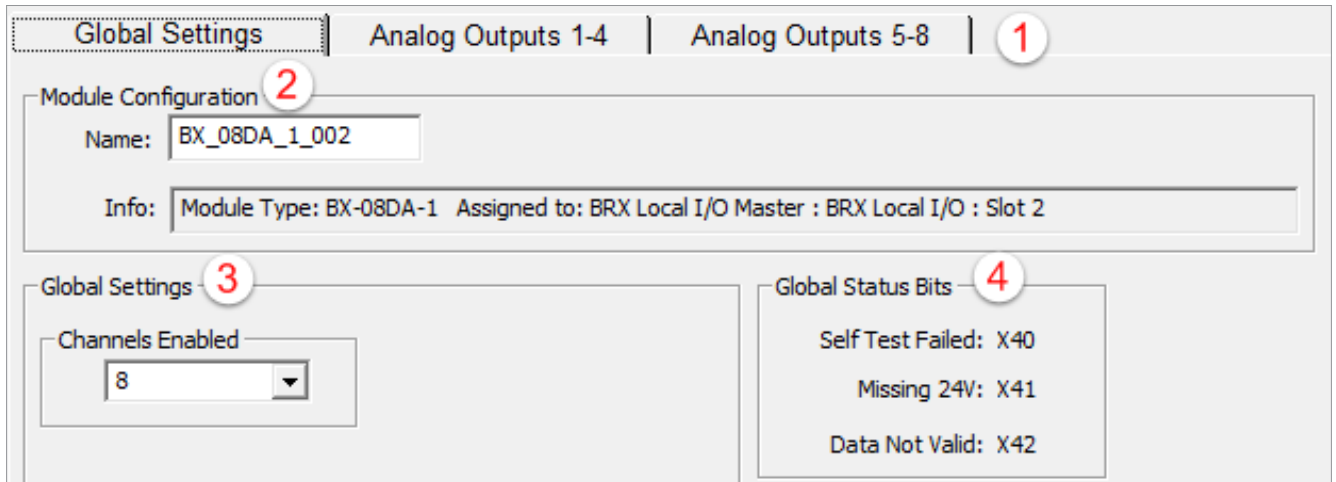

1. The module options are divided into subsets across multiple tabs. Click the appropriate tab to edit the configuration.

2. *Module Configuration*

Name – Each module comes with a default name. This may be changed by the user to better identify the module if desired.

Info – This is the system description of the module. It is static and may not be changed.

3. *Global Settings*

Channels Enabled – Select how many channels will be used. The default is all channels. Selecting fewer channels may increase the update frequency. See the module specifications for details.

4. *Global Status Bits*

Self Test Failed – This bit will be On if the module has failed its internal self-test. In this case, the module is likely bad and should be replaced.

Missing 24V – This bit will be On if the external 24VDC power is missing. Check the 24VDC power connection on the module terminal block.

Data Not Valid – This bit will be On if the module does not have the latest configuration parameters or the module has not been configured at all. Reload the program into the CPU and power cycle.

BX-xxDA-1 Analog Current Source Output, continued

5. *Analog Output x*

These settings are for each channel of the analog module.

Drop-down menu - Select the range of the analog input here.

Enable 16 bit unipolar data – Check this box to change the raw count range from a signed decimal bipolar data format to an unsigned decimal data format. This may require that Casting be used in the program in order to properly access the data. Refer to the chart of Data Range Specifications earlier in this chapter to see if the registers must be accessed with Casting.

6. *WXx*

Range – The number of Raw counts for the selected channel on the module.

Units/Ct – The amount of current that will equal 1 raw count.

Broken Transmitter – The input register that, when On, will indicate that the loop is broken.

7. *RXx*

Range – The engineering units to which the raw counts are scaled.

Units/Ct – The number of raw counts that will equal 1 scaled engineering unit.

8. *Enable Scaling from WYx to RYx*

RYx Min – The minimum value of the engineering units for scaling.

RYx Max – The maximum value of the engineering units for scaling.

WYx Min – The minimum value of the raw counts to scale.

WYx Max – The maximum value of the raw counts to scale.

Counts/mA – Use these buttons to change the raw scaling to counts or milliamps.

Clamp WYx – If this box is checked, WYx will clamp at the minimum and maximum scaled values.

BX-xxDA-2B Analog Voltage Output

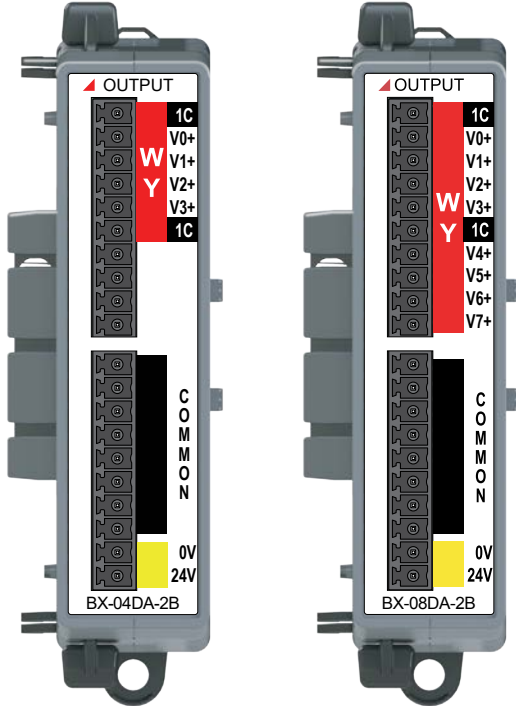
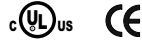

BX-04DA-2B

Analog Output Expansion Module
4-ch, ±10 VDC, ±5 VDC,
0–5 VDC, 0–10 VDC,
16-bit

BX-08DA-2B

Analog Output Expansion Module
8-ch, ±10 VDC, ±5 VDC,
0–5 VDC, 0–10 VDC,
16-bit

Terminal Blocks or
ZIPLink Cables Sold
Separately



We recommend using prewired ZIPLink cables and connection modules. If you wish to hand-wire your module, a removable terminal block is available. See Wiring Termination Selection in this chapter for all options.

Analog Voltage Output Specifications		
	BX-04DA-2B	BX-08DA-2B
Outputs per Module	4	8
Commons	1	
Module Signal Output Range	±10 VDC, ±5 VDC, 0–5 VDC, 0–10 VDC (Default)	
Signal Resolution	16-bit, 15-bit (Default)	
Resolution Value of LSB	See Data Range Specifications table	
Output Type	Voltage outputs sourcing/sinking at 10mA (example 10V @ 1kΩ load).	
Output Value in Fault Mode	Voltage outputs 0V (Unipolar or Bipolar)	
Minimum Load Impedance	1kΩ	
Maximum Capacitive Load	1000pF	
Allowed Load Type	Grounded	
Maximum Continuous Overload	15mA	
All Channel Update Rate	3ms	
Maximum Inaccuracy	0.2% of range	
Maximum Full Scale Calibration Error	±0.08% of range	
Maximum Offset Calibration Error	±0.04% of range	
Accuracy vs. Temperature	±25PPM/°C maximum	
Maximum Crosstalk	+3μV	
Linearity Error (end to end)	±0.01% of range	
Output Stability and Repeatability	±0.02% of full range after 10 min. warmup (typical)	
Output Ripple	150 μV/mA	
Output Settling Time	200μs	
Channel to Backplane Isolation	1800VAC applied for one second	
Channel to Channel Isolation	None	
Loop Fusing (External)	Fast-acting 0.032A recommended	
Backplane Power Consumption	0.1 W	
External DC Power Required	Class 2 or LPS power supply 24VDC (±20%) 100mA	
Heat Dissipation	2.9 W	3.1 W
Weight	104g (3.7 oz)	
Agency Approvals	UL 61010-1 and UL 61010-2-201 File E139594, Canada and USA CE (EN 61131-2 EMC, EN 61010-1 and EN 61010-2-201 Safety)	
Software Version Required (Do-more! Designer Programming Software)	2.3 or later	2.1 or later

IMPORTANT!



Hot-Swapping Information

Note: This device cannot be Hot Swapped.

BX-xxDA-2B Analog Voltage Output, continued

Data Range Specifications							
Selection	Description	Enable 16 bit Unchecked (15 bit Resolution, Default) ¹			Enable 16 bit Checked (16 bit Resolution)		
		Raw Counts	Castings ²	μ V Per Count	Raw Counts	Castings ²	μ V Per Count
0–10V	unipolar 10VDC	0–32767	-	305	0–65535	WYn:U	152
0–5V	unipolar 5VDC	0–32767	-	152	0–65535	WYn:U	76
\pm 10V	bipolar 10VDC	-	-		-32768 to 32767	-	305
\pm 5V	bipolar 5VDC	-	-		-32768 to 32767	-	152

1. Bipolar ranges default to 16-bit resolution.

2. For more information on Casting, refer to Help topic DMD0309 in the Do-more! Designer Software.

The module reserves the first 24 bits of unused contiguous space in the X register, aligned to an 8-bit word boundary, for status reporting. Error flags for this module are laid out within its status register space as described in the table below.

Error Flag Specifications									
	MSB								LSB
1st Byte of unused X Registers									
Module Status	-	-	-	-	-	Data Not Valid	Missing 24VDC	Self Test Failed	
2nd Byte of unused X Registers									
Unused	-	-	-	-	-	-	-	-	-
3rd Byte of unused X Registers									
Unused	-	-	-	-	-	-	-	-	-



NOTE: The Data Not Valid flag should always be tested and confirmed to be in the "Off" state in your PLC program before writing to the analog module.

BX-xxDA-2B Analog Voltage Output, continued

Analog Voltage Output Wiring

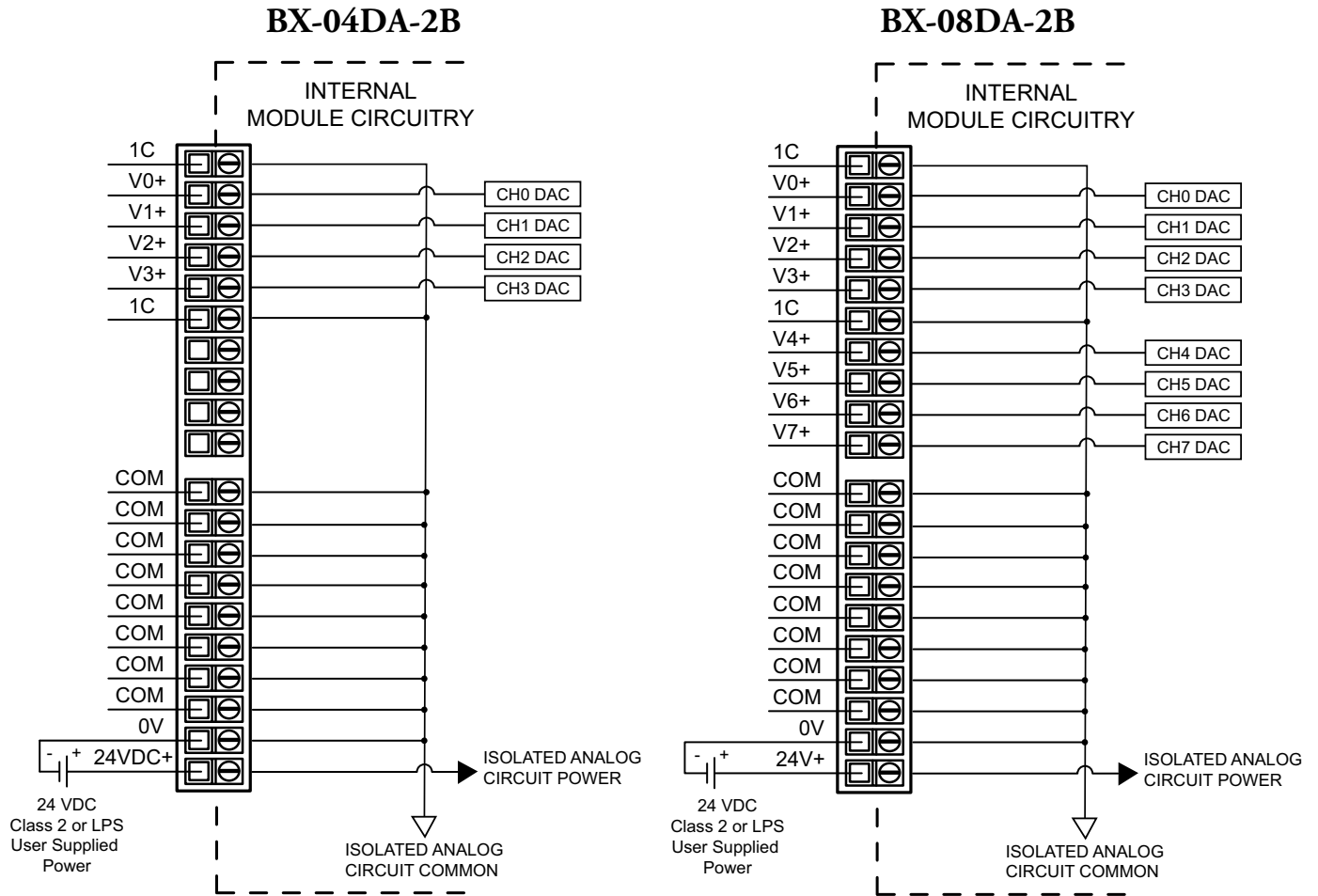

Analog Voltage Output Circuit

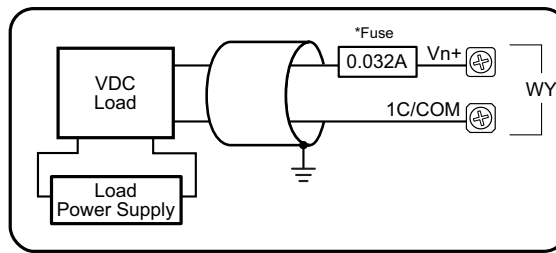

*An Edison S500-32-R 0.032A fast-acting fuse is recommended for all analog voltage inputs, analog outputs, and current loops.

NOTE: Shield should be connected only at one end, to ground at the source device.

BX-xxDA-2B Analog Voltage Output, continued

Software Setup

After the module is installed, open the Do-more! Designer programming software, connect to the BRX MPU and open the **Configure Module** dialog as described at the beginning of this chapter.

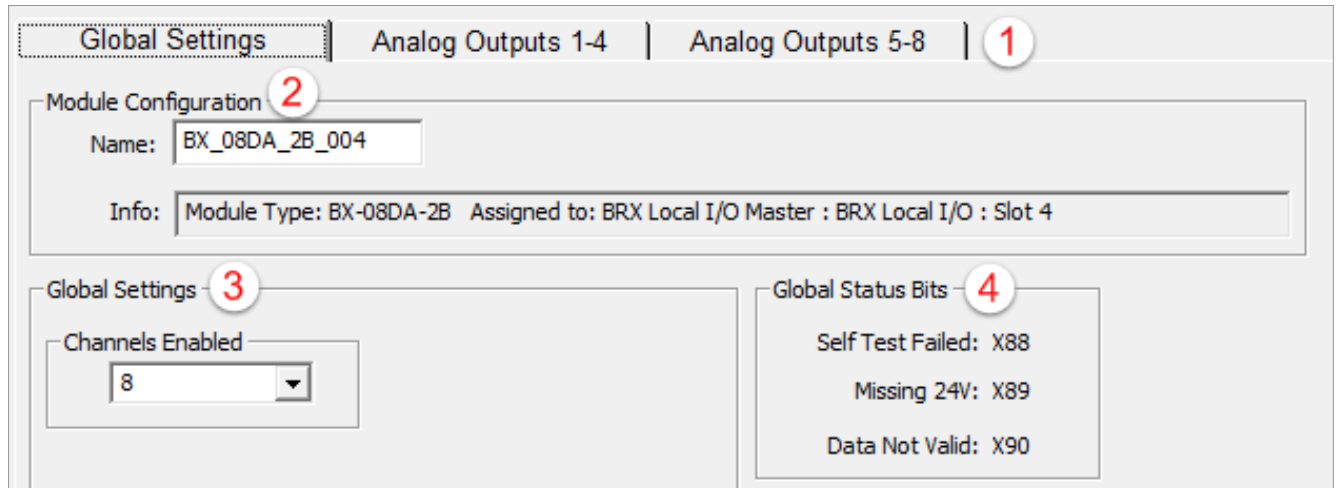

1. The module options are divided into subsets across multiple tabs. Click the appropriate tab to edit the configuration.

2. *Module Configuration*

Name – Each module comes with a default name. This may be changed by the user to better identify the module if desired.

Info – This is the system description of the module. It is static and may not be changed.

3. *Global Settings*

Channels Enabled – Select how many channels will be used. The default is all channels. Selecting fewer channels may increase the update frequency. See the module specifications for details.

4. *Global Status Bits*

Self Test Failed – This bit will be On if the module has failed its internal self-test. In this case, the module is likely bad and should be replaced.

Missing 24V – This bit will be On if the external 24VDC power is missing. Check the 24VDC power connection on the module terminal block.

Data Not Valid – This bit will be On if the module does not have the latest configuration parameters or the module has not been configured at all. Reload the program into the CPU and power cycle.

BX-xxDA-2B Analog Voltage Output, continued

5. *Analog Output x*

These settings are for each channel of the analog module.

Drop-down menu - Select the range of the analog input here.

Enable 16 bit unipolar data – Check this box to change the raw count range from a signed decimal bipolar data format to an unsigned decimal data format. This may require that Casting be used in the program in order to properly access the data. Refer to the chart of Data Range Specifications earlier in this chapter to see if the registers must be accessed with Casting.

6. *WXx*

Range – The number of Raw counts for the selected channel on the module.

Units/Ct – The amount of current that will equal 1 raw count.

7. *RXx*

Range – The engineering units to which the raw counts are scaled.

Units/Ct – The number of raw counts that will equal 1 scaled engineering unit.

8. *Enable Scaling from WYx to RYx*

RYx Min – The minimum value of the engineering units for scaling.

RYx Max – The maximum value of the engineering units for scaling.

WYx Min – The minimum value of the raw counts to scale.

WYx Max – The maximum value of the raw counts to scale.

Counts/VDC – Use these buttons to change the raw scaling to counts or milliamps.

Clamp WYx – If this box is checked, WYx will clamp at the minimum and maximum scaled values.

BX-xxDA-3 Universal Analog Output

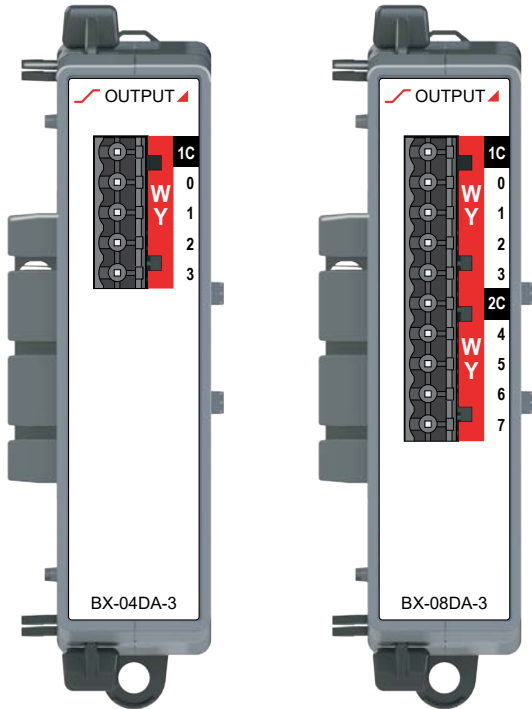

BX-04DA-3

Analog Output Expansion Module
4-ch, 0-20mA/4-20mA, ±10 VDC, ±5 VDC, 0-5 VDC, 0-10 VDC, 16-bit*

BX-08DA-3

Analog Output Expansion Module
8-ch, 0-20mA/4-20mA, ±10 VDC, ±5 VDC, 0-5 VDC, 0-10 VDC, 16-bit*

Terminal Blocks or ZIPLink Cables Sold Separately



We recommend using prewired ZIPLink cables and connection modules. If you wish to hand-wire your module, a removable terminal block is available. See Wiring Termination Selection in this chapter for all options.

IMPORTANT!



Hot-Swapping Information

Note: This device cannot be Hot Swapped.

Analog Universal Current/Voltage Output Specifications

	BX-04DA-3	BX-08DA-3
Outputs per Module	4	8
Commons	1	2
Module Signal Output Range	0-20mA, 4-20mA, ±20mA, ±10 VDC, ±5 VDC, 0-5 VDC (Default), 0-10 VDC	
Signal Resolution	16-bit at ±10V or ±20mA*	
Resolution Value of LSB	See Data Range Specifications table	
Output Type	Current Sinking/Sourcing up to 5V Voltage outputs sourcing/sinking at 10mA (example 10V @ 1kΩ load).	
Output Value in Fault Mode	Current outputs ~0mA Voltage outputs 0V (Unipolar or Bipolar)	
Minimum Voltage Load Impedance	1kΩ	
Maximum Current Load Impedance	250Ω	
Allowed Load Type	Grounded	
Maximum Continuous Overload	Indefinitely	
All Channel Update Rate	1.0 ms	
Maximum Inaccuracy	±0.1% of HW full scale (65 counts)	
Maximum Full Scale Calibration Error	±0.1% of HW full scale (65 counts)	
Conversion Method	Amplified Divide-by-2 Resistor String	
Linearity Error (end to end)	±0.1% of HW full scale (65 counts)	
Output Stability and Repeatability	±0.02% of HW full scale (12 counts) after 10 min. warmup (typical)	
Output Settling Time	10µs	
Channel to Backplane Isolation	1500VAC applied for one second, 1C to 2C	
Channel to Channel Isolation	None	
Loop Fusing (External)	Fast-acting 0.032A recommended	
Backplane Power Consumption (Max)	2.4 W	5 W
Heat Dissipation	2.25 W	5.5 W
Weight	98g (3.5 oz)	
Agency Approvals	UL 61010-2 File E185989, Canada and USA	
Software Version Required (Do-more! Designer Programming Software)	2.7 or later	

* 16-bit resolution is only available when a bipolar output range is selected.

BX-xxDA-3 Universal Analog Output, continued

Data Range Specifications				
Selection	Description	Raw Counts	Casting ¹	Per Count
-20–20mA	bipolar -20 to 20mA	-32768 to 32767	-	0.61 μ A
4–20mA	unipolar 4–20mA	6553–32767	-	0.61 μ A
0–10V	unipolar 10VDC	0–32767	-	305 μ V
0–5V	unipolar 5VDC	0–32767	-	153 μ V
\pm 10V	bipolar 10VDC	-32768 to 32767	-	305 μ V
\pm 5V	bipolar 5VDC	-32768 to 32767	-	153 μ V

1. For more information on Casting, refer to Help topic DMD0309 in the Do-more! Designer Software.

Analog Current/Voltage Output Wiring

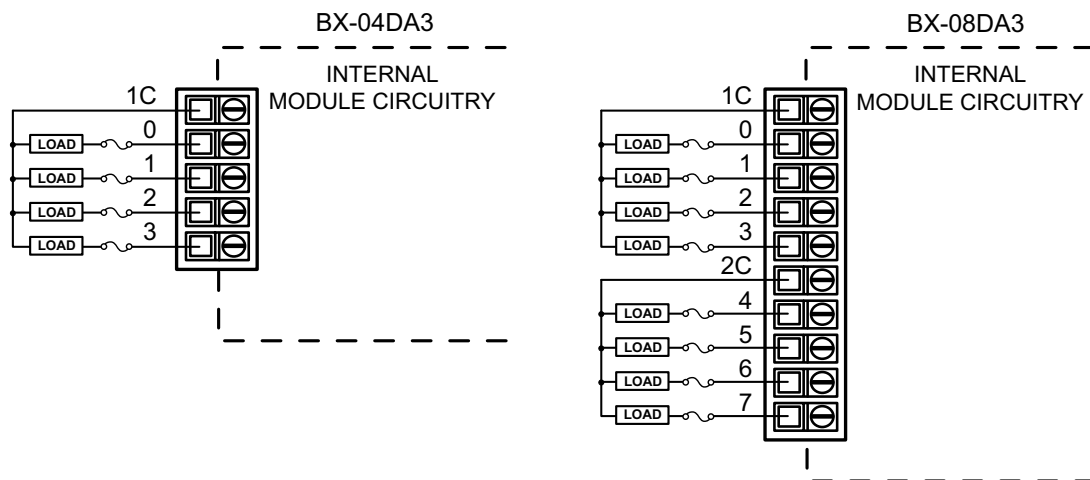

Analog Current Source Output Circuit

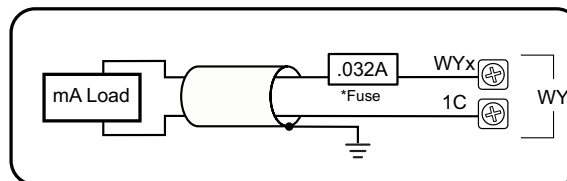

Analog Voltage Output Circuit

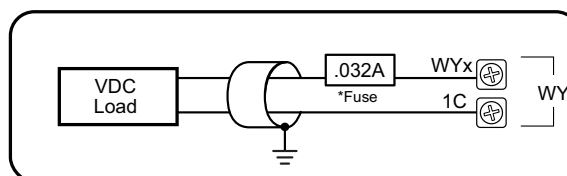

NOTE: Shield should be connected only at one end, to ground at the source device.

*An Edison S500-32-R 0.032A fast-acting fuse is recommended for all analog voltage inputs, analog outputs, and current loops.

BX-xxDA-3 Universal Analog Output, continued

Software Setup

After the module is installed, open the Do-more! Designer programming software, connect to the BRX MPU and open the **Configure Module** dialog as described at the beginning of this chapter.

Setup BX-08DA-3 Module

Module Configuration Name: BX-08DA-3-002 Info: Module Type: BX-08DA-3 Assigned to: BRX Local I/O Master : BRX Local I/O : Slot 2

Analog Outputs 0-3 | Analog Outputs 4-7

Analog Output 0
 0 - 5VDC

WY1
 Range: 0 - 32767
 Resolution: 15 bits
 Units/Ct: 153uV

RY1
 Range: 0.00 - 100.00
 Units/Ct: 0.003052

Enable Scaling from RY1 to WY1

RY1 Min 0 WY1 Min 0
 RY1 Max 100 WY1 Max 32767

Counts VDC
 Clamp WY1

1. *Analog Output x*

These settings are for each channel of the analog module.

Drop-down menu - Select the range of the analog input here.

2. *WXx*

Range – The number of Raw counts for the selected channel on the module.

Units/Ct – The amount of current that will equal 1 raw count.

3. *RXx*

Range – The engineering units to which the raw counts are scaled.

Units/Ct – The number of raw counts that will equal 1 scaled engineering unit.

4. *Enable Scaling from WYx to RYx*

RYx Min – The minimum value of the engineering units for scaling.

RYx Max – The maximum value of the engineering units for scaling.

WYx Min – The minimum value of the raw counts to scale.

WYx Max – The maximum value of the raw counts to scale.

Counts/VDC – Use these buttons to change the raw scaling to counts or milliamps.

Clamp WYx – If this box is checked, WYx will clamp at the minimum and maximum scaled values.

BX-xADxDA-1 Combination Analog Current Input/Output

The BX-xADxDA-1 Combination Analog Current Input/Output Expansion Modules provide two (2) or four (4) points current sinking inputs and two (2) current sourcing outputs.

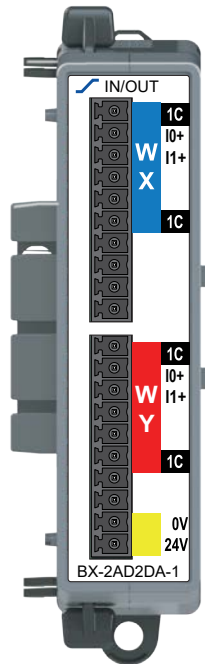

BX-2AD2DA-1

Combination Analog Module
 Input: 2-pt, 0–20mA/4–20mA, Sinking
 Output: 2-pt, 0–20mA/4–20mA, Sourcing

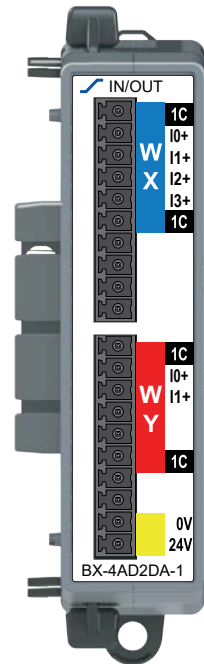

BX-4AD2DA-1

Combination Analog Module
 Input: 4-pt, 0–20mA/4–20mA, Sinking
 Output: 2-pt, 0–20mA/4–20mA, Sourcing



Terminal Blocks or
 ZIPLink Cables Sold
 Separately

We recommend using prewired ZIPLink cables and connection modules. If you wish to hand-wire your module, a removable terminal block is available. See Wiring Termination Selection in this chapter for all options.



IMPORTANT!



Hot-Swapping Information

Note: This device cannot be Hot Swapped.

BX-xADxDA-1 Combination Analog Current Input/Output, continued

Analog Current Sinking Input Specifications		
	BX-2AD2DA-1	BX-4AD2DA-1
Inputs per Module	2	4
Commons	1	
Module Signal Input Range	0–20mA, 4–20mA (Default)	
Signal Resolution	16-bit, 15-bit (Default)	
Resolution Value of LSB	See Data Range Specifications table	
Input Impedance	256Ω±0.1%, 1/10th watt	
All Channel Update Rate	30ms	45ms
Maximum Continuous Overload	±28mA	
Sample Duration Time	100μs per channel	
Hardware Filter Characteristics	Low Pass 2nd order, –3dB @ 15kHz	
Conversion Method	Successive Approximation	
Linearity Error (end to end)	±0.09% of range	
Input Stability and Repeatability	±0.05% of range (after 10 min. warmup)	
Full Scale Calibration Error	±0.1% of range	
Offset Calibration Error	±0.1% of range	
Accuracy vs. Temperature	±25PPM/°C maximum	
Maximum Inaccuracy	0.1% of range (incl. Temperature Drift)	
Maximum Crosstalk	–90dB, 1 LSB	
Channel to Backplane Isolation	1800VAC applied for one second	
Channel to Channel Isolation	None	

Analog Current Source Output Specifications		
	BX-2AD2DA-1	BX-4AD2DA-1
Outputs per Module	2	2
Commons	1	
Module Signal Output Range	0–20mA, 4–20mA (Default)	
Signal Resolution	16-bit, 15-bit (Default)	
Resolution Value of LSB	See Data Range Specifications table	
Output Type	Current Sourcing up to 20mA	
Output Value in Fault Mode	0mA in 0–20mA mode, 4mA in 4–20mA mode	
Maximum Load Impedance	700Ω	
Maximum Capacitive Load	1000pF	
Allowed Load Type	Grounded	
Maximum Continuous Overload	30mA	
All Channel Update Rate	2.5 ms per enabled channel	
Maximum Inaccuracy	±0.1% of range	
Maximum Full Scale Calibration Error	±0.08% of range	
Maximum Offset Calibration Error	±0.08% of range	
Conversion Method	Successive Approximation	
Accuracy vs. Temperature	±25PPM/°C maximum	
Maximum Crosstalk	+10μV	
Linearity Error (end to end)	±0.08% of range	
Output Stability and Repeatability	±0.03% of full range after 10 minute warmup (typical)	
Output Ripple	±0.03% of range/mA	
Output Settling Time	350μs	
Channel to Backplane Isolation	1800VAC applied for one second	
Channel to Channel Isolation	None	

BX-xADxDA-1 Combination Analog Current Input/Output, continued

Module General Specifications		
	BX-2AD2DA-1	BX-4AD2DA-1
Weight	110g (3.9 oz)	
Heat Dissipation	3.75 W Max	
Backplane Power Consumption	0.3 W	
External DC Power Required	Class 2 or LPS power supply 24VDC ($\pm 20\%$) 100mA	
Loop Fusing (External)	Fast-acting 0.032A recommended	
Agency Approvals	UL 61010-1 and UL 61010-2-201 File E139594, Canada and USA CE (EN 61131-2 EMC, EN 61010-1 and EN 61010-2-201 Safety)	
Software Version Required	Do-more! Designer version 2.6 or later	

Data Range Specifications							
Selection	Description	Enable 16 bit Unchecked (15 bit Resolution, Default)			Enable 16 bit Checked (16 bit Resolution)		
		Raw Counts	Casting*	μA Per Count	Raw Counts	Casting*	μA Per Count
0–20mA	unipolar 0–20mA	0–32767	-	0.61	0–65535	WYn:U	0.31
4–20mA	unipolar 4–20mA	0–32767	-	0.49	0–65535	WYn:U	0.24

* For more information on Casting, refer to Help topic DMD0309 in the Do-more! Designer Software.

The module reserves the first 24 bits of unused contiguous space in the X register, aligned to an 8-bit word boundary, for status reporting. Error flags for this module are laid out within its status register space as described in the table below.

Error Flag Specifications								
	MSB							LSB
1st Byte of unused X Registers								
Module Status	-	-	-	-	Data Not Valid (Out)	Data Not Valid (In)	Missing 24VDC	Self Test Failed
2nd Byte of unused X Registers								
Channel Open (Broken Transmitter)*	-	-	-	-	Channel 4	Channel 3	Channel 2	Channel 1
3rd Byte of unused X Registers								
Unused	-	-	-	-	-	-	-	-

* Input channels. 4–20mA mode only. Broken Transmitter bits will turn on below ~3.75 mA.



NOTE: The Data Not Valid flag should always be tested and confirmed to be in the "Off" state in your PLC program before reading from or writing to the analog module.

BX-xADxDA-1 Combination Analog Current Input/Output, continued

Analog Current Input/Output Wiring

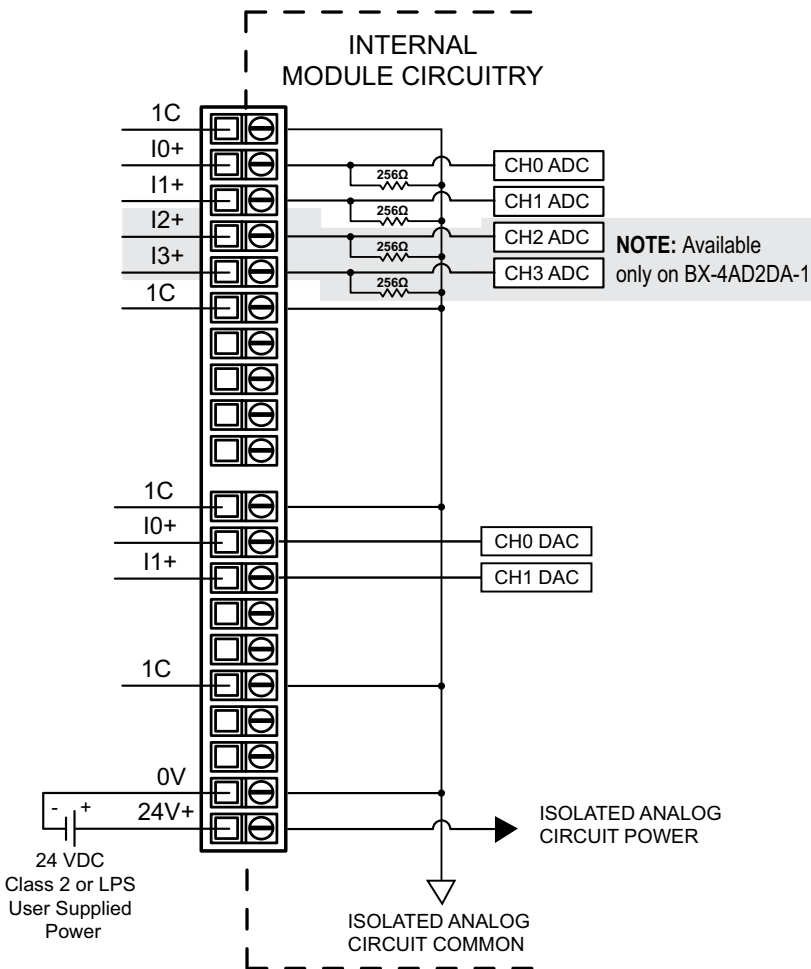

Analog Current Sinking Input Circuits

*An Edison S500-32-R 0.032A fast-acting fuse is recommended for all analog voltage inputs, analog outputs, and current loops.

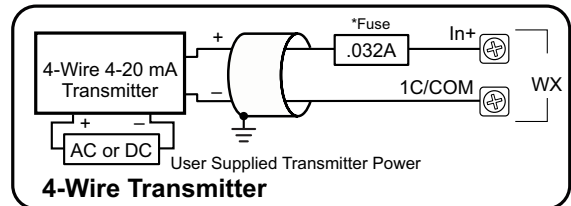
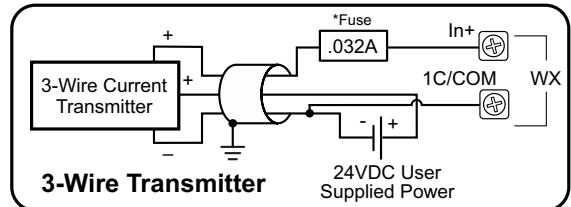
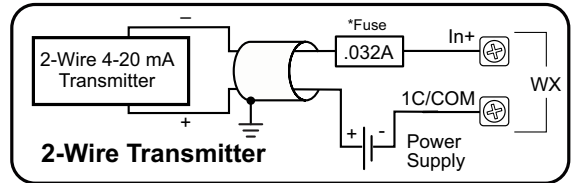

NOTE: Shield should be connected only at one end, to ground at the source device.

Analog Current Source Output

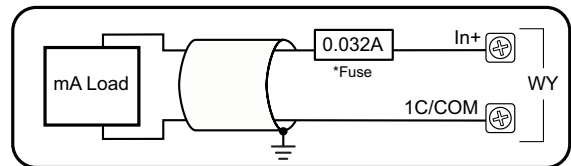

*An Edison S500-32-R 0.032A fast-acting fuse is recommended for all analog voltage inputs, analog outputs, and current loops.

NOTE: Shield should be connected only at one end, to ground at the source device.

BX-xADxDA-2B Combination Analog Voltage Input/Output

The BX-xADxDA-2B Combination Analog Voltage Input/Output Expansion Modules provide two (2) or four (4) points voltage inputs and two (2) voltage outputs.

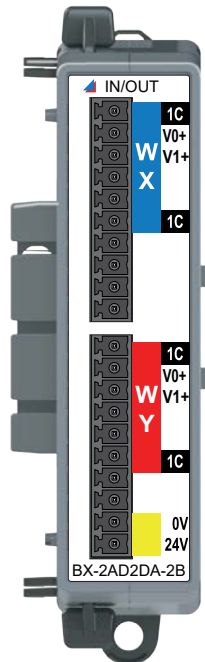

BX-2AD2DA-2B

Combination Analog Module
2 Channels In, 2 Channels Out
 ± 10 VDC, ± 5 VDC, 0–5 VDC, 0–10 VDC

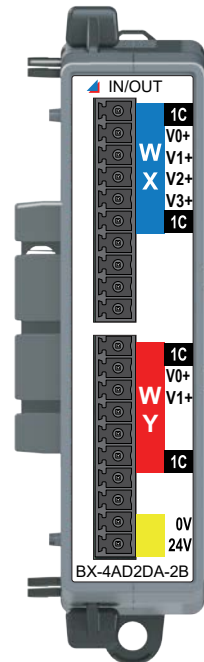

BX-4AD2DA-2B

Combination Analog Module
4 Channels In, 2 Channels Out
 ± 10 VDC, ± 5 VDC, 0–5 VDC, 0–10 VDC



Terminal Blocks or
ZIPLink Cables Sold
Separately

We recommend using prewired ZIPLink cables and connection modules. If you wish to hand-wire your module, a removable terminal block is available. See Wiring Termination Selection in this chapter for all options.



IMPORTANT!



Hot-Swapping Information

Note: This device cannot be Hot Swapped.

BX-xADxDA-2B Combination Analog Voltage Input/Output, continued

Analog Voltage Input Specifications		
	BX-2AD2DA-2B	BX-4AD2DA-2B
Inputs per Module	2	4
Commons	1	
Module Signal Input Range	±10 VDC, ±5 VDC, 0–5 VDC, 0–10 VDC (Default)	
Signal Resolution	16-bit, 15 bit (Default)	
Resolution Value of LSB	See Data Range Specifications table	
Input Impedance	>1MΩ	
All Channel Update Rate	30ms	45ms
Maximum Continuous Overload	15mA	
Sample Duration Time	100μs per channel	
Hardware Filter Characteristics	Low Pass 2nd order, –3dB @ 15kHz	
Conversion Method	Successive Approximation	
Accuracy vs. Temperature	±25PPM/°C maximum	
Maximum Inaccuracy	0.15% of full range (over temp)	
Linearity Error (end to end)	±0.09% of range	
Input Stability and Repeatability	±0.06% of range (after 10 min. warmup)	
Full Scale Calibration Error	±0.1% of range	
Offset Calibration Error	±0.1% of range	
Maximum Crosstalk	–90dB, 1 LSB	
Channel to Backplane Isolation	1800VAC applied for one second	
Channel to Channel Isolation	None	

Analog Voltage Output Specifications		
	BX-2AD2DA-2B	BX-4AD2DA-2B
Outputs per Module	2	2
Commons	1	
Module Signal Output Range	±10 VDC, ±5 VDC, 0–5 VDC, 0–10 VDC (Default)	
Signal Resolution	16-bit, 15-bit (Default)	
Resolution Value of LSB	See Data Range Specifications table	
Output Type	Voltage outputs sourcing/sinking at 10mA	
Output Value in Fault Mode	Voltage outputs 0V (unipolar or bipolar)	
Maximum Load Impedance	1kΩ	
Maximum Capacitive Load	1000pF	
Allowed Load Type	Grounded	
Maximum Continuous Overload	15mA	
All Channel Update Rate	2.5 ms per enabled channel	
Maximum Inaccuracy	±0.2% of range	
Maximum Full Scale Calibration Error	±0.08% of range	
Maximum Offset Calibration Error	±0.04% of range	
Conversion Method	Successive Approximation	
Accuracy vs. Temperature	±25PPM/°C maximum	
Maximum Crosstalk	+3μV	
Linearity Error (end to end)	±0.04% of range	
Output Stability and Repeatability	±0.03% of full range after 10 minute warmup (typical)	
Output Ripple	150μV/mA	
Output Settling Time	200μs	
Channel to Backplane Isolation	1800VAC applied for one second	
Channel to Channel Isolation	None	

BX-xADxDA-2B Combination Analog Voltage Input/Output, continued

Module General Specifications		
	BX-2AD2DA-2B	BX-4AD2DA-2B
Weight	98g (3.4 oz)	
Heat Dissipation	0.3 W Max	
Backplane Power Consumption	0.1 W	0.3 W
External DC Power Required	Class 2 or LPS power supply 24VDC ($\pm 20\%$) 50mA	
Loop Fusing (External)	Fast-acting 0.032A recommended	
Agency Approvals	UL 61010-1 and UL 61010-2-201 File E139594, Canada and USA CE (EN 61131-2 EMC, EN 61010-1 and EN 61010-2-201 Safety)	
Software Version Required	Do-more! Designer version 2.6 or later	

Data Range Specifications							
Selection	Description	Enable 16 bit Unchecked (15 bit Resolution, Default) ¹			Enable 16 bit Checked (16 bit Resolution)		
		Raw Counts	Casting ²	μV Per Count	Raw Counts	Casting ²	μV Per Count
0–10V	unipolar 10VDC	0–32767	-	305	0–65535	WYn:U	152
0–5V	unipolar 5VDC	0–32767	-	152	0–65535	WYn:U	76
$\pm 10\text{V}$	bipolar 10VDC	-	-		-32768 to 32767	-	305
$\pm 5\text{V}$	bipolar 5VDC	-	-		-32768 to 32767	-	152

1. Bipolar ranges default to 16-bit resolution.

2. For more information on Casting, refer to Help topic DMD0309 in the Do-more! Designer Software.

The module reserves the first 24 bits of unused contiguous space in the X register, aligned to an 8-bit word boundary, for status reporting. Error flags for this module are laid out within its status register space as described in the table below.

Error Flag Specifications									
	MSB								LSB
1st Byte of unused X Registers									
Module Status	-	-	-	-	Data Not Valid (Out)	Data Not Valid (In)	Missing 24VDC	Self Test Failed	
2nd Byte of unused X Registers									
Channel Out of Range*	-	-	-	-	Channel 4	Channel 3	Channel 2	Channel 1	
3rd Byte of unused X Registers									
Unused	-	-	-	-	-	-	-	-	-

* Input channels.



NOTE: The Data Not Valid flag should always be tested and confirmed to be in the "Off" state in your PLC program before reading from or writing to the analog module.

BX-xADxDA-2B Combination Analog Voltage Input/Output, continued

Analog Voltage Input/Output Wiring

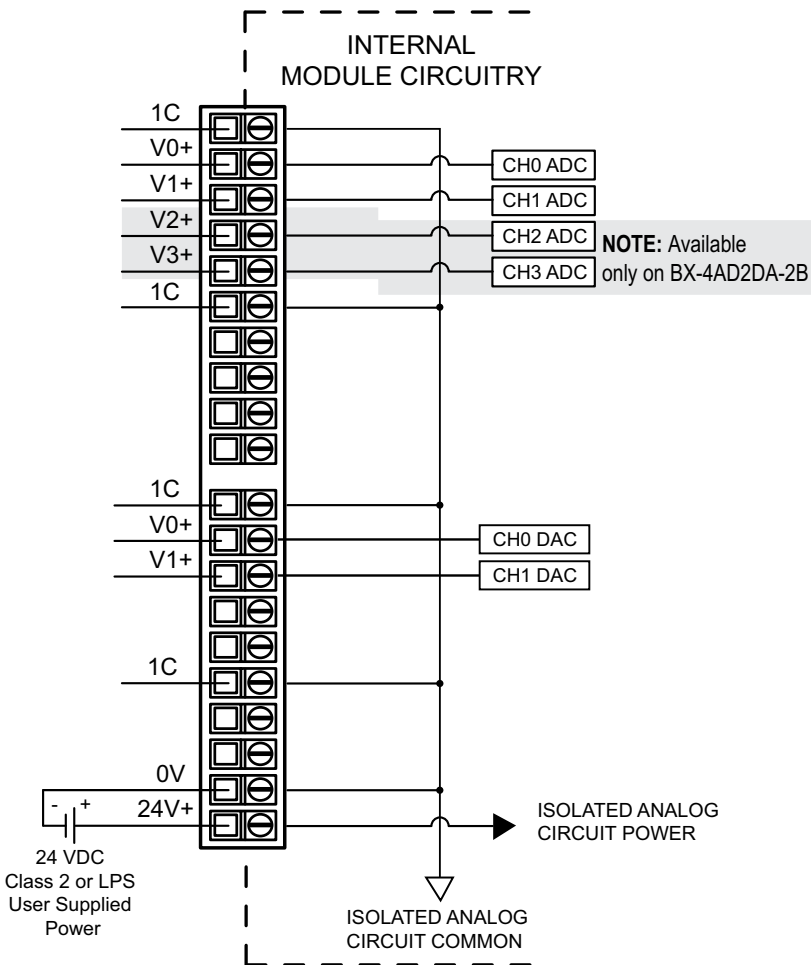

Analog Voltage Input Circuits

*An Edison S500-32-R 0.032A fast-acting fuse is recommended for all analog voltage inputs, analog outputs, and current loops.

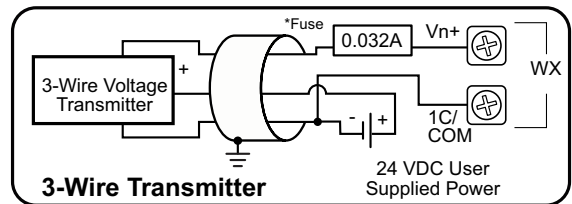
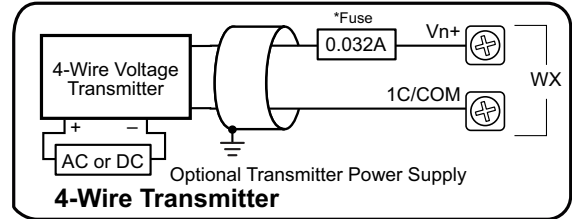

NOTE: For maximum accuracy, jumper unused inputs to common.

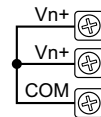

NOTE: Shield should be connected only at one end, to ground at the source device.

Analog Voltage Output Circuit

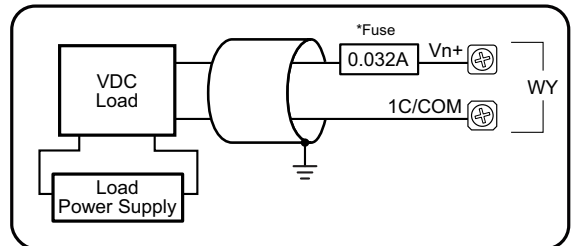

*An Edison S500-32-R 0.032A fast-acting fuse is recommended for all analog voltage inputs, analog outputs, and current loops.

NOTE: Shield should be connected only at one end, to ground at the source device.

BX-xADxDA-3 Universal Combination Analog Input/Output

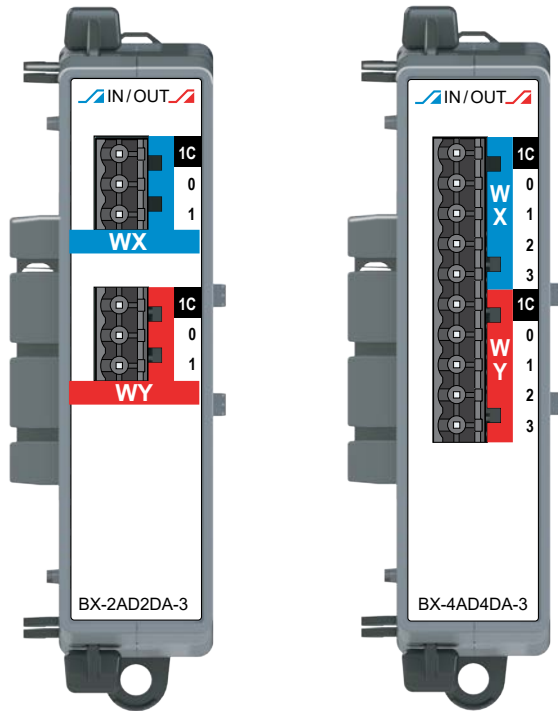

Analog Universal Current/Voltage Input Specifications		
	BX-2AD2DA-3	BX-4AD4DA-3
Inputs per Module	2	4
Commons	1	
Module Signal Input Range	0–20mA, 4–20mA, ± 20 mA ± 10 VDC, ± 5 VDC, 0–5 VDC (Default), 0–10 VDC	
Signal Resolution	16-bit at ± 10 V or ± 20 mA*	
Resolution Value of LSB	See Data Range Specifications table	
Input Impedance	Current Input: 249 Ω Voltage Input: 100k Ω	
All Channel Update Rate	1.2 ms	
Over Current Circuit Detection Time	< 1second	
Maximum Continuous Overload	± 40 mA current mode, ± 20 V voltage mode	
Sample Duration Time	1.2 ms	
Hardware Filter Characteristics	Active Low Pass, -3dB @ 1kHz	
Conversion Method	Delta Sigma	
Linearity Error (end to end)	$\pm 0.1\%$ of HW full scale (65 counts)	
Input Stability and Repeatability (after 10 min. warmup)	$\pm 0.02\%$ of HW full scale (13 counts)	
Full Scale Calibration Error	$\pm 0.1\%$ of HW full scale (65 counts)	
Offset Calibration Error	$\pm 0.05\%$ of HW full scale (32 counts)	
Accuracy vs. Temperature	± 25 PPM / $^{\circ}$ C maximum	
Maximum Inaccuracy	$\pm 0.2\%$ of HW full scale (130 counts)	
Maximum Crosstalk	1 count	
Channel to Backplane Isolation	1800VAC applied for one second	
Channel to Channel Isolation	None	
Loop Fusing (External)	Fast-acting 0.032A recommended	

BX-2AD2DA-3

Combination Analog Module
2 Channels In, 2 Channels Out
0–20mA/4–20mA, Sink/Source
 ± 10 VDC, ± 5 VDC,
0–5 VDC, 0–10 VDC

BX-4AD4DA-3

Combination Analog Module
4 Channels In, 4 Channels Out
0–20mA/4–20mA, Sink/Source
 ± 10 VDC, ± 5 VDC,
0–5 VDC, 0–10 VDC

Terminal Blocks or
ZIPLink Cables Sold
Separately



We recommend using prewired ZIPLink cables and connection modules. If you wish to hand-wire your module, a removable terminal block is available. See Wiring Termination Selection in this chapter for all options.

IMPORTANT!



Hot-Swapping Information

Note: This device cannot be Hot Swapped.

* 16-bit resolution is only available when a bipolar input range is selected.

BX-xADxDA-3 Universal Combination Analog Input/Output, continued

Analog Universal Current/Voltage Output Specifications		
	BX-2AD2DA-3	BX-4AD4DA-3
Outputs per Module	2	4
Commons	1	
Module Signal Output Range	0–20mA, 4–20mA, ±20mA ±10VDC, ±5VDC, 0–5VDC (Default), 0–10VDC	
Signal Resolution	16-bit at ±10V or ±20mA*	
Resolution Value of LSB	See Data Range Specifications table	
Output Type	Current Sinking/Sourcing up to 5V Voltage outputs Sinking/Sourcing at 10mA (example 10V @ 1kΩ load).	
Output Value in Fault Mode	Current outputs ~0mA Voltage outputs 0V (Unipolar or Bipolar)	
Minimum Load Impedance	1kΩ	
Maximum Current Load Impedance	500Ω	
Allowed Load Type	Grounded	
Maximum Continuous Overload	Indefinitely	
All Channel Update Rate	1.0 ms	
Maximum Inaccuracy	±0.1% of HW full scale (65 counts)	
Maximum Full Scale Calibration Error	±0.1% of HW full scale (65 counts)	
Conversion Method	Amplified Divide-by-2 Resistor String	
Linearity Error (end to end)	±0.1% of HW full scale (65 counts)	
Output Stability and Repeatability	±0.02% of HW full scale (12 counts) after 10 min. warmup	
Output Settling Time	10μs	
Channel to Backplane Isolation	1800VAC applied for one second	
Channel to Channel Isolation	None	
Loop Fusing (External)	Fast-acting 0.032A recommended	

* 16-bit resolution is only available when a bipolar output range is selected.

Analog Universal Current/Voltage General Specifications		
	BX-2AD2DA-3	BX-4AD4DA-3
Backplane Power Consumption	2.5 W	3.75 W
Heat Dissipation	2.5 W	4.0 W
Weight	98g [3.5 oz]	
Agency Approvals	UL 61010-2 File E185989, Canada and USA	
Software Version Required (Do-more! Designer Programming Software)	2.7 or later	

BX-xADxDA-3 Universal Combination Analog Input/Output, continued

Data Range Specifications				
Selection	Description	Raw Counts	Casting ¹	Per Count
-20–20mA	bipolar -20 to 20mA	-32768 to 32767	-	0.61 μ A
4–20mA	unipolar 4–20mA	6553 to 32767	-	0.61 μ A
0–10V	unipolar 10VDC	0–32767	-	305 μ V
0–5V	unipolar 5VDC	0–32767	-	153 μ V
\pm 10V	bipolar 10VDC	-32768 to 32767	-	305 μ V
\pm 5V	bipolar 5VDC	-32768 to 32767	-	153 μ V

1. For more information on Casting, refer to Help topic DMD0309 in the Do-more! Designer Software.

The module reserves the first 8 bits of unused contiguous space in the X register, aligned to an 8-bit word boundary, for status reporting. Error flags for this module are laid out within its status register space as described in the table below.

Error Flag Specifications									
	MSB								LSB
1st Byte of unused X Registers									
Out of Range	-	-	-	-	Input Channel 4	Input Channel 3	Input Channel 2	Input Channel 1	

Channel Bit Error Flag is set when a channel's input signal meets the conditions in the table below.

Channel Bit Error Conditions	
Selected Data Range	Error Condition
-20–20mA	< -20.0 mA or > 20.0 mA
4–20mA	< 2.0 mA (i.e., Broken Transmitter, no upper error condition for 4–20mA)
0–10V	< -0.05 V or > 10.0 V
0–5V	< -0.05 V or > 5.05 V
\pm 10V	< -10.0 V or > 10.0 V
\pm 5V	< -5.05 V or > 5.05 V

Analog Input/Output Wiring

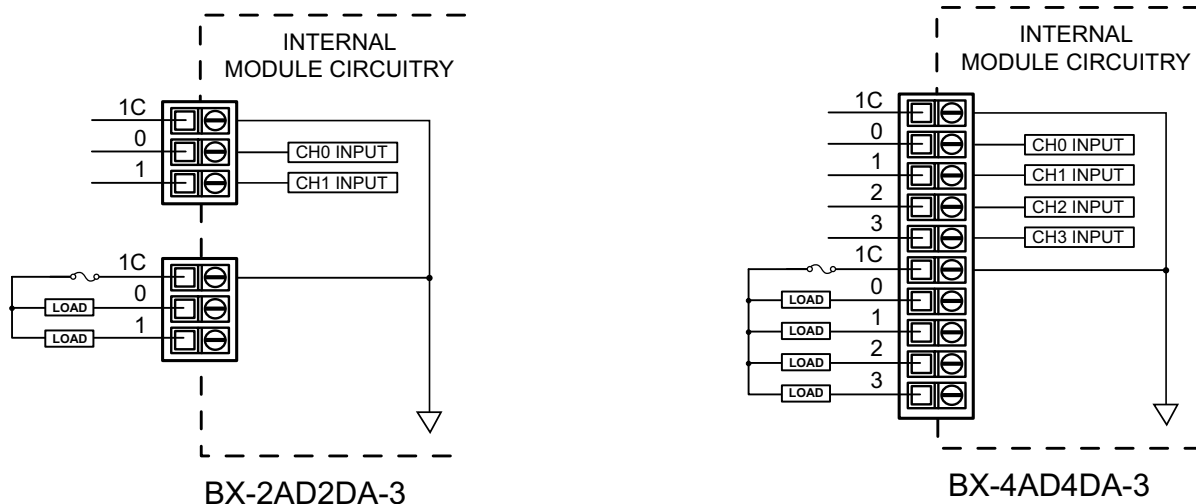

BX-xADxDA-3 Universal Combination Analog Input/Output, continued

Analog Current Sinking Input Circuits

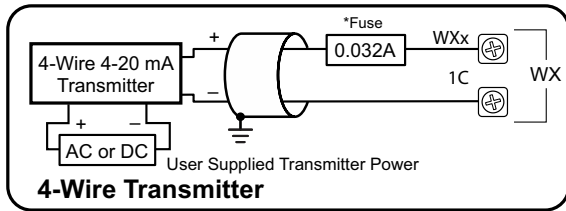
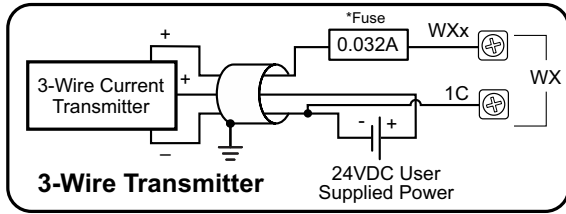
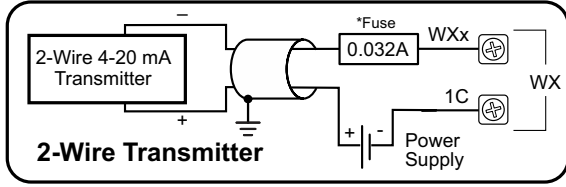

*NOTE: An Edison S500-32-R 0.032A fast-acting fuse is recommended for all analog voltage inputs, analog outputs, and current loops.

Analog Voltage Input Circuits

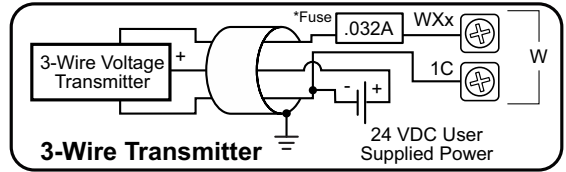
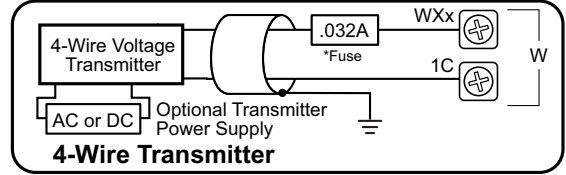

Analog Current Source Output Circuit

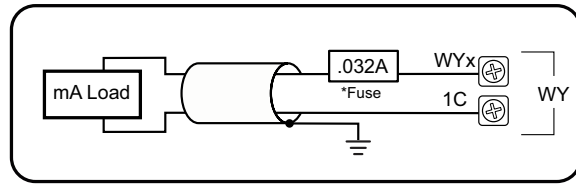

Analog Voltage Output Circuit

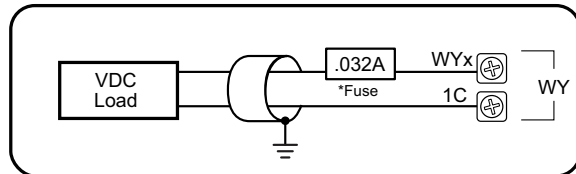

NOTE: Shield should be connected only at one end, to ground at the source device.

*An Edison S500-32-R 0.032A fast-acting fuse is recommended for all analog voltage inputs, analog outputs, and current loops.

BX-xADxDA-3 Universal Combination Analog Input/Output, continued

Software Setup

After the module is installed, open the Do-more! Designer programming software, connect to the BRX MPU and open the Configure Module dialog as described at the beginning of this chapter.

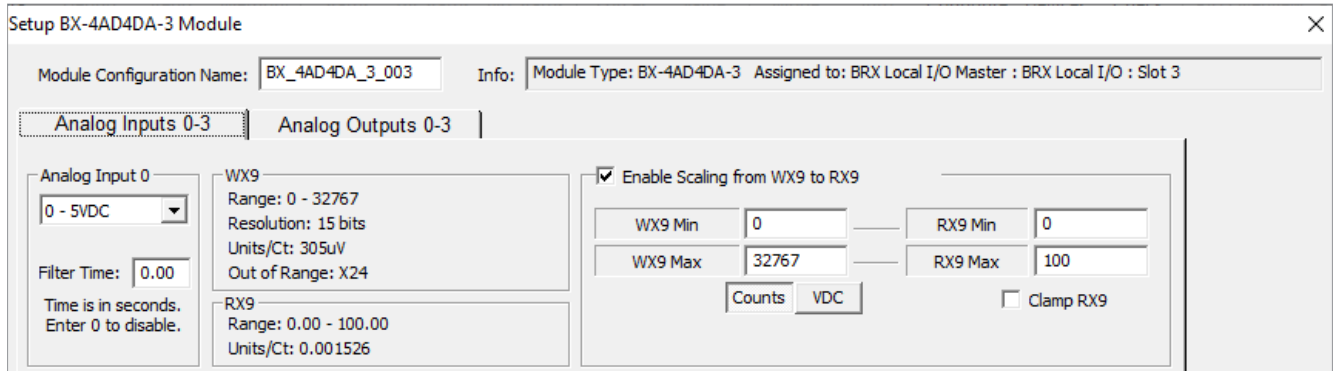

The module options are divided into subsets across multiple tabs. Click the appropriate tab to edit the configuration.

1. *Analog Input x*

These settings are for each channel of the analog module.

Drop-down menu – Select the range of the analog input here.

Filter Time – Time to average the Analog signal in seconds.

2. *WXx*

Range – The number of Raw counts for the selected channel on the module.

Units/Ct – The amount of voltage that will equal 1 raw count.

Out of Range – The input register that, when On, will indicate that the voltage is outside of the selected range.

3. *RXx*

Range – The engineering units to which the raw counts are scaled.

Units/Ct – The number of raw counts that will equal 1 scaled engineering unit.

4. *Enable Scaling from WXx to RXx*

WXx Min – The minimum value of the raw counts to scale.

WXx Max – The maximum value of the raw counts to scale.

RXx Min – The minimum value of the engineering units for scaling.

RXx Max – The maximum value of the engineering units for scaling.

Counts/VDC – Use these buttons to change the raw scaling to counts or volts.

Clamp RXx – If this box is checked, RXx will clamp at the minimum and maximum scaled values.

BX-xADxDA-3 Universal Combination Analog Input/Output, continued

Setup BX-4AD4DA-3 Module ×

Module Configuration Name: Info: Module Type: BX-4AD4DA-3 Assigned to: BRX Local I/O Master : BRX Local I/O : Slot 3

Analog Inputs 0-3 | **Analog Outputs 0-3**

Analog Output 0

WY9
Range: 0 - 32767
Resolution: 15 bits
Units/Ct: 153uV

Enable Scaling from RY9 to WY9

RY9 Min WY9 Min
RY9 Max WY9 Max

Counts VDC
 Clamp WY9

RY9
Range: 0.00 - 100.00
Units/Ct: 0.001526

1. *Analog Output x*

These settings are for each channel of the analog module.

Drop-down menu - Select the range of the analog input here.

2. *WXx*

Range – The number of Raw counts for the selected channel on the module.

Units/Ct – The amount of current that will equal 1 raw count.

3. *RXx*

Range – The engineering units to which the raw counts are scaled.

Units/Ct – The number of raw counts that will equal 1 scaled engineering unit.

4. *Enable Scaling from WYx to RYx*

RYx Min – The minimum value of the engineering units for scaling.

RYx Max – The maximum value of the engineering units for scaling.

WYx Min – The minimum value of the raw counts to scale.

WYx Max – The maximum value of the raw counts to scale.

Counts/VDC – Use these buttons to change the raw scaling to counts or milliamps.

Clamp WYx – If this box is checked, WYx will clamp at the minimum and maximum scaled values.

BX-4RTD4DA-1 Combination RTD Input/Current Output

The 4RTD4DA-1 Combination RTD Input/Current Output Expansion Module provides four (4) resistance temperature detector inputs and four (4) current sourcing outputs.

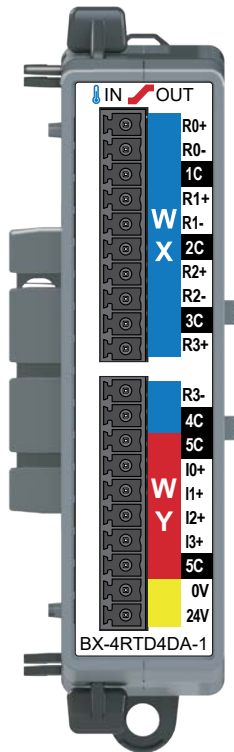

BX-4RTD4DA-1

RTD Temperature Input/
Analog Output Expansion Module
4-pt RTD Temperature Input
4-pt Universal Analog Output

BX-RTB10 Terminal Blocks Included.
The BX-RTB10-1 or BX-RTB10-2 can
also be used and can be purchased
separately.

RTD Input Specifications

Input Channels	4 Differential
Commons	4
Resolution	16-bit, 0.1°(C or F) See Data Range Specifications table
Input Ranges (RTD Types)	Pt100: -200° to 850°C (-328° to 1562°F) (Default) Pt1000: -200° to 595°C (-328° to 1103°F) JPt100: -100° to 450°C (-148° to 842°F) 10Ω Cu: -200° to 260°C (-328° to 500°F) ±3°C 25Ω Cu: -200° to 260°C (-328° to 500°F) ±3°C 120Ω Ni: -80° to 260°C (-112° to 500°F)
Resistance Input Ranges	0 – 10,000 Ω 0 – 6,250 Ω 0 – 3,125 Ω 0 – 1,562.5 Ω 0 – 781.2 Ω 0 – 390.6 Ω 0 – 195.3 Ω
Excitation Current	210μA
RTD Linearization	Automatic
Accuracy vs. Temperature	±10 ppm per °C (maximum)
Full Scale Calibration	±1°C
Offset Calibration Error	±1°C (±3°C for 10Ω/25Ω Cu)
Maximum Inaccuracy	±1°C (±3°C for 10Ω/25Ω Cu maximum) (excluding RTD error) (including temperature drift)
Warmup Time	2 minutes for ±0.2% repeatability
All Channel Update Rate	Single channel sample duration times the number of enabled channels
Filter Characteristics	Digital filter cutoff frequencies: 16Hz, 470Hz
Sample Duration Time	Dependent on digital filter settings: 125ms@16Hz, 4ms@470Hz
Open Circuit Detection Time	Positive full-scale reading within 2s
Maximum Ratings	Fault protected inputs to ±50V
Max. Common Mode Voltage	4VDC
Common Mode Rejection	-90dB @ DC, -150dB @ 50/60Hz
Conversion Method	Sigma-Delta



NOTE: This device does not support
ZIPLink Wiring Systems.

IMPORTANT!



Hot-Swapping Information

Note: This device cannot be Hot Swapped.

BX-4RTD4DA-1 Combination RTD Input/Current Output, continued

Analog Current Source Output Specifications	
Outputs per Module	4
Commons	1
Module Signal Output Range	0–20mA, 4–20mA (Default)
Signal Resolution	16-bit, 15-bit (Default)
Resolution Value of LSB	See Data Range Specifications table
Output Type	Current Sourcing up to 20mA
Output Value in Fault Mode	0mA in 0–20mA mode, 4mA in 4–20mA mode
Maximum Load Impedance	700Ω
Maximum Capacitive Load	1000pF
Allowed Load Type	Grounded
Maximum Continuous Overload	30mA
All Channel Update Rate	2.5 ms per enabled channel
Maximum Inaccuracy	±0.1% of range
Maximum Full Scale Calibration Error	±0.08% of range
Maximum Offset Calibration Error	±0.08% of range
Conversion Method	Successive approximation
Accuracy vs. Temperature	±25PPM/°C maximum
Maximum Crosstalk	+10μV
Linearity Error (end to end)	±0.08% of range
Output Stability and Repeatability	±0.03% of full range after 10 minute warmup (typical)
Output Ripple	±0.03% of range/mA
Output Settling Time	320μs
Channel to Backplane Isolation	1800VAC applied for one second
Channel to Channel Isolation	None
Loop Fusing (External)	Fast-acting 0.032A recommended

Module General Specifications	
Weight	110g (3.9 oz)
Heat Dissipation	3W Max
Backplane Power Consumption	0.1 W
External DC Power Required	Class 2 or LPS power supply 24VDC (±20%) 125mA
Agency Approvals	UL 61010-1 and UL 61010-2-201 File E139594, Canada and USA CE (EN 61131-2 EMC, EN 61010-1 and EN 61010-2-201 Safety)
Software Version Required	Do-more! Designer version 2.6 or later

BX-4RTD4DA-1 Combination RTD Input/Current Output, continued

Data Range Specifications		
Selection	Description	Raw Counts ¹
Pt100	Pt100 Platinum RTD	°C: -2000 to 8500 °F: -3280 to 15620
Pt1000	Pt1000 Platinum RTD	°C: -2000 to 5950 °F: -3280 to 11030
JPt100	JPt100 Platinum RTD	°C: -1000 to 4500 °F: -1480 to 8420
10Ω Cu	10Ω Copper RTD	°C: -2000 to 2600 °F: -3280 to 5000
25Ω Cu	25Ω Copper RTD	°C: -2000 to 2600 °F: -3280 to 5000
120Ω Ni	120Ω Nickel RTD	°C: -800 to 2600 °F: -1120 to 5000
0–10,000 Ω		0–10000
0–6,250 Ω		0–6250
0–3,125 Ω		0–3125
0–1,562.5 Ω		0–15625 ²
0–781.2 Ω		0–7812 ²
0–390.6 Ω		0–3906 ²
0–195.3 Ω		0–1953 ²

1. Temperatures have one implied decimal place (e.g., raw count of -1900 is -190.0°).

2. Certain resistance ranges have one implied decimal place (e.g., raw count of 7812 is 781.2Ω).

The module reserves the first 24 bits of unused contiguous space in the X register, aligned to an 8-bit word boundary, for status reporting. Error flags for this module are laid out within its status register space as described in the table below.

Error Flag Specifications								
	MSB					LSB		
1st Byte of unused X Registers								
Module Status	-	-	-	-	-	Data Not Valid	Missing 24VDC	Self Test Failed
2nd Byte of unused X Registers								
Channel Out of Range*	-	-	-	-	Channel 4	Channel 3	Channel 2	Channel 1
3rd Byte of unused X Registers								
Burn Out**	-	-	-	-	Channel 4	Channel 3	Channel 2	Channel 1

* Input channels.

** Output channels.



NOTE: The Data Not Valid flag should always be tested and confirmed to be in the "Off" state in your PLC program before reading from or writing to the analog module.

BBX-4RTD4DA-1 Combination RTD Input/Current Output, continued

Analog RTD/Resistance Input and Current Output Wiring

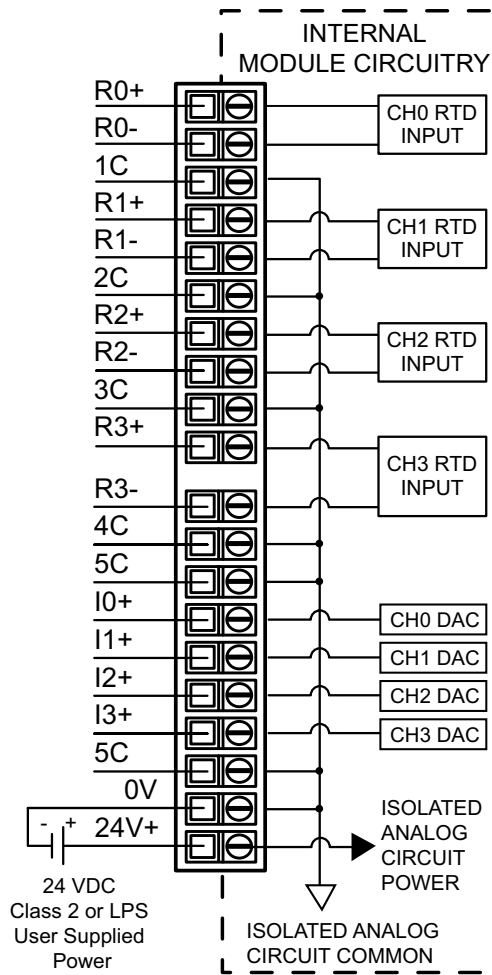

BX-4RTD4DA-1 Combination RTD Input/Current Output, continued

RTD Input Circuits

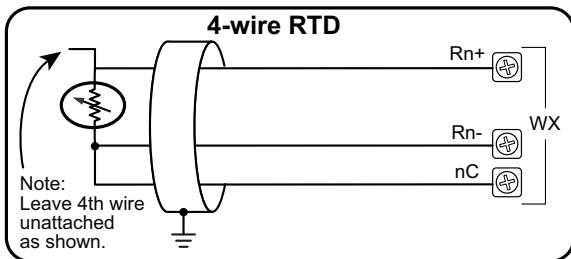
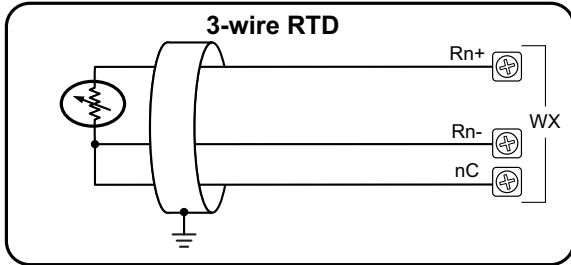
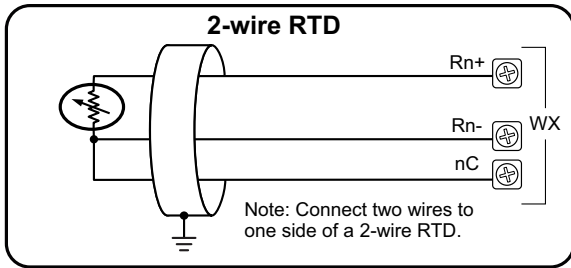

Resistance Input

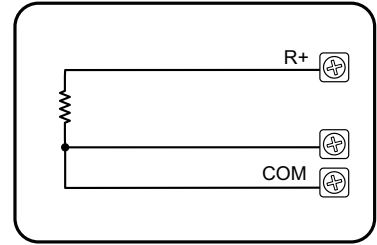

Notes for maximum accuracy:

1. For 2-wire RTD, attach a third wire to module common.
2. R+, R-, and COM wires to an RTD must be equal length and type. Refer to RTD manufacturer's recommendations.
3. Do not use cable shield as sensing wire.
4. When applicable, connect shield to RTD common only, otherwise connect to module common only. Do not connect shield to both ends.
5. Jumper unused inputs to common.

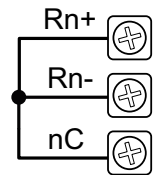

Analog Current Source Output

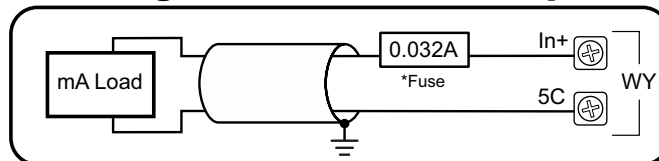

*An Edison S500-32-R 0.032A fast-acting fuse is recommended for all analog voltage inputs, analog outputs, and current loops.

NOTE: Shield should be connected only at one end, to ground at the source device.

BX-4THM4DA-1 Combination Thermocouple Input/Current Output

The 4THM4DA-1 Combination Thermocouple Input/Current Output Expansion Module provides four (4) thermocouple inputs and four (4) current sourcing outputs.

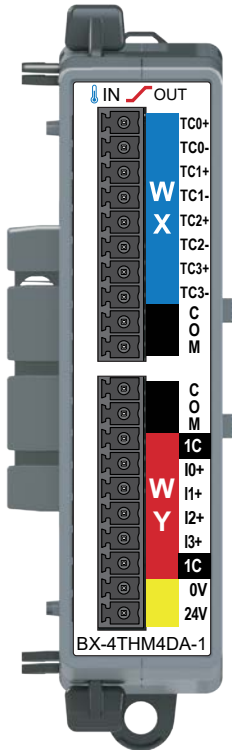

BX-4THM4DA-1

Thermocouple Temperature Input/
Analog Output Expansion Module
4-pt Thermocouple Temperature Input
4-pt Universal Analog Output

BX-RTB10 Terminal Blocks Included.
The BX-RTB10-1 or BX-RTB10-2 can
also be used and can be purchased
separately.

Thermocouple Input Specifications	
Input Channels	4 Differential
Commons	NA
Input Impedance	>1MΩ
Resolution	16-bit, 0.1°(C or F) See Data Range Specifications table
Thermocouple Input Ranges	Type J: -190° to 760°C (-310° to 1400°F) (Default) Type E: -210° to 1000°C (-346° to 1832°F) Type K: -150° to 1372°C (-238° to 2502°F) Type R: 65° to 1768°C (149° to 3214°F) Type S: 65° to 1768°C (149° to 3214°F) Type T: -230° to 400°C (-382° to 752°F) Type B: 529° to 1820°C (984° to 3308°F) Type N: -70° to 1300°C (-94° to 2372°F) Type C: 65° to 2320°C (149° to 4208°F)
Cold Junction Compensation	Automatic
Thermocouple Linearization	Automatic
Accuracy vs. Temperature	±50PPM per °C (maximum)
Maximum Inaccuracy– Temperature	±3°C maximum (excluding thermocouple error) (including temperature drift)
Linear Voltage Input Ranges	0–39mV ±39mV ±78mV 0–156mV ±156mV 0–1.25 V
Maximum Inaccuracy–Voltage	0.06% @ 25°C, 0.10% @ 0–60°C
All Channel Update Rate	1.6 s
Sample Duration Time	270ms
Open Circuit Detection Time	Within 2–10s
Maximum Ratings	Fault protected inputs to ±50V
Common Mode Range	0.6 V (@ 16-bit Resolution)
Common Mode Rejection	100dB @ DC and 130dB @ 60Hz
Conversion Method	Sigma-Delta



NOTE: This device does not support
ZIPLink Wiring Systems.

IMPORTANT!



Hot-Swapping Information

Note: This device cannot be Hot Swapped.

BX-4THM4DA-1 Combo Thermocouple Input/Current Output, continued

Analog Current Source Output Specifications	
Outputs per Module	4
Commons	1
Module Signal Output Range	0–20mA, 4–20mA (Default)
Signal Resolution	16-bit, 15-bit (Default)
Resolution Value of LSB	See Data Range Specifications table
Output Type	Current Sourcing up to 20mA
Output Value in Fault Mode	0mA in 0–20mA mode, 4mA in 4–20mA mode
Maximum Load Impedance	700Ω
Maximum Capacitive Load	1000pF
Allowed Load Type	Grounded
Maximum Continuous Overload	30mA
All Channel Update Rate	2.5 ms per enabled channel
Maximum Inaccuracy	±0.1% of range
Maximum Full Scale Calibration Error	±0.08% of range
Maximum Offset Calibration Error	±0.08% of range
Conversion Method	Successive approximation
Accuracy vs. Temperature	±25PPM/°C maximum
Maximum Crosstalk	+10μV
Linearity Error (end to end)	±0.08% of range
Output Stability and Repeatability	±0.03% of full range after 10 minute warmup (typical)
Output Ripple	±0.03% of range/mA
Output Settling Time	320μs
Channel to Backplane Isolation	1800VAC applied for one second
Channel to Channel Isolation	None
Loop Fusing (External)	Fast-acting 0.032A recommended

Module General Specifications	
Weight	110g (3.9 oz)
Heat Dissipation	3.75 W Max
Backplane Power Consumption	0.3 W
External DC Power Required	Class 2 or LPS power supply 24VDC (±20%) 125mA
Agency Approvals	UL 61010-1 and UL 61010-2-201 File E139594, Canada and USA CE (EN 61131-2 EMC, EN 61010-1 and EN 61010-2-201 Safety)
Software Version Required	Do-more! Designer version 2.6 or later

BX-4THM4DA-1 Combo Thermocouple Input/Current Output, continued

Data Range Specifications							
Selection	Description	Enable 16 bit Unchecked (15 bit Resolution, Default) ¹			Enable 16 bit Checked (16 bit Resolution)		
		Raw Counts	Casting ²	µV Per Count	Raw Counts ³	Casting ²	µV Per Count
Type J	Type J	-	-		°C: -1900 to 7600 °F: -3100 to 14000	-	-
Type E	Type E	-	-		°C: -2100 to 10000 °F: -3460 to 18320	-	-
Type K	Type K	-	-		°C: -1500 to 13720 °F: -2380 to 25020	-	-
Type R	Type R	-	-		°C: 650 to 17680 °F: 1490 to 32140	-	-
Type S	Type S	-	-		°C: 650 to 17680 °F: 1490 to 32140	-	-
Type T	Type T	-	-		°C: -2300 to 4000 °F: -380 to 7520	-	-
Type B	Type B	-	-		°C: 5290 to 18200 °F: 9840 to 33080	WXn:U	-
Type N	Type N	-	-		°C: -700 to 13000 °F: -940 to 23720	-	-
Type C	Type C	-	-		°C: 650 to 23200 °F: 1490 to 42080	WXn:U	-
0–39 mVDC	Unipolar 39 mVDC	0–32767	-	1.2	0–65535	WXn:U	0.6
-39–39 mVDC	Bipolar 39 mVDC	-	-		-32768 to 32767	-	1.2
-78–78 mVDC	Bipolar 78 mVDC	-	-		-32768 to 32767	-	2.4
0–156 mVDC	Unipolar 156 mVDC	0–32767	-	4.8	0–65535	WXn:U	2.4
-156–156 mVDC	Bipolar 156 mVDC	-	-		-32768 to 32767	-	4.8
0–1.25 VDC	Unipolar 1.25 VDC	0–32767	-	38.1	0–65535	WXn:U	19.1

1. Thermocouple and bipolar ranges default to 16-bit resolution.

2. For more information on Casting, refer to Help topic DMD0309 in the Do-more! Designer Software.

3. Temperatures have one implied decimal place (e.g., raw count of -1900 is -190.0°).

The module reserves the first 24 bits of unused contiguous space in the X register, aligned to an 8-bit word boundary, for status reporting. Error flags for this module are laid out within its status register space as described in the table below.

Error Flag Specifications								
	MSB							LSB
1st Byte of unused X Registers								
Module Status	-	-	-	-	Data Not Valid (Out)	Data Not Valid (In)	Missing 24VDC	Self Test Failed
2nd Byte of unused X Registers								
Channel Out of Range*	-	-	-	-	Channel 4	Channel 3	Channel 2	Channel 1
3rd Byte of unused X Registers								
Burn Out**	-	-	-	-	Channel 4	Channel 3	Channel 2	Channel 1

* Input channels.

** Output channels.



NOTE: The Data Not Valid flag should always be tested and confirmed to be in the "Off" state in your PLC program before reading from or writing to the analog module.

BX-4THM4DA-1 Combo Thermocouple Input/Current Output, continued

Analog Thermocouple/Voltage Input and Current Output Wiring

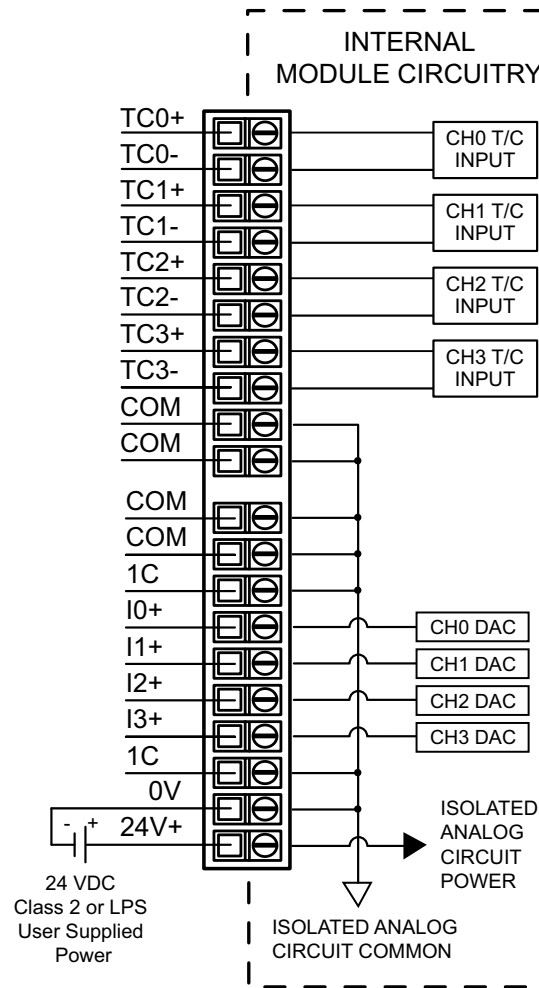

BX-4THM4DA-1 Combo Thermocouple Input/Current Output, continued

Thermocouple Input Circuits

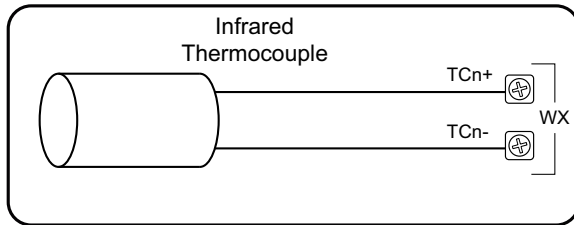
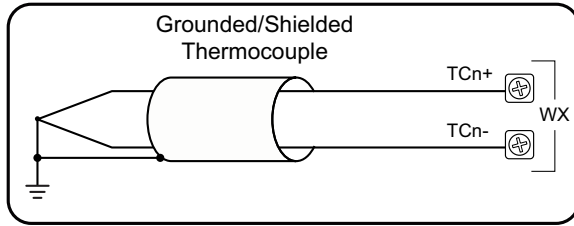
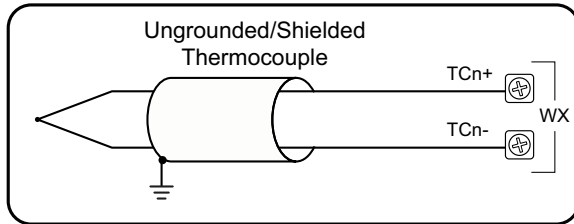

NOTE: Thermocouple extension wire and proper thermocouple terminal blocks must be used to extend thermocouples. AutomationDirect thermocouple wire is recommended.

Analog Voltage Input Circuits

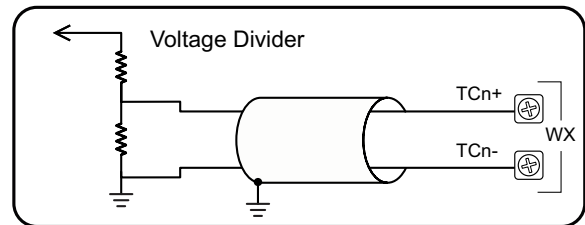
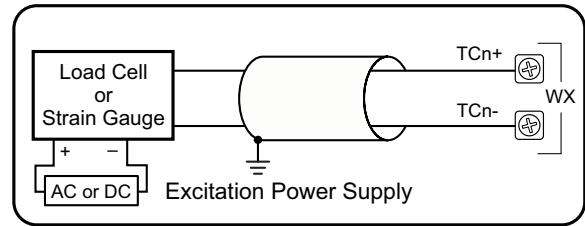
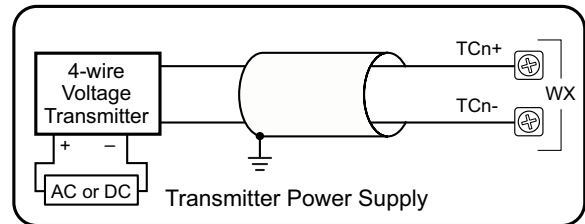

For maximum accuracy, jumper unused inputs. 

NOTE: Shield should be connected only at one end, to ground at the source device.



NOTE: With grounded thermocouples, take precautions to prevent having a voltage potential between thermocouple tips. A voltage of 1.25 V or greater between tips will skew measurements.

Analog Current Source Output

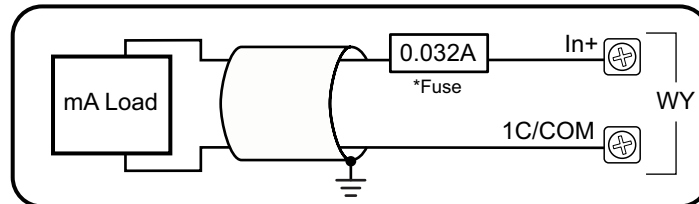

*An Edison S500-32-R 0.032A fast-acting fuse is recommended for all analog voltage inputs, analog outputs, and current loops.

NOTE: Shield should be connected only at one end, to ground at the source device.

BX-4UT4DA-3 Universal Temperature Input/Analog Output

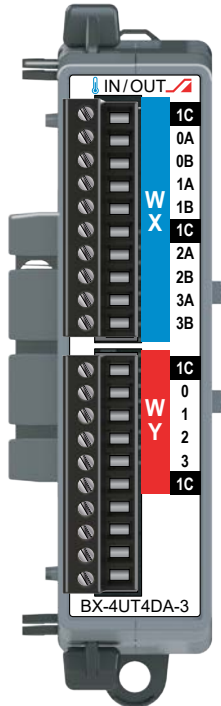

BX-4UT4DA-3

Universal Temperature Input/
Analog Output Expansion Module
4-pt Universal Temperature Input
4-pt Universal Analog Output

BX-RTB10 Terminal Blocks Included.

The BX-RTB10-1 or BX-RTB10-2 can also be used and can be purchased separately.



NOTE: This device does not support ZIPLink Wiring Systems.

IMPORTANT!



Hot-Swapping Information

Note: This device cannot be Hot Swapped.

Universal Temperature Input Specifications

Input Channels	4 Differential
Commons	1
Input Impedance	>5M Ω
Resolution	24-bit, 0.1 $^{\circ}$ C or F See Data Range Specifications table
All Channel Update Rate	1s max (4 thermocouples enabled) 700ms max (4RTD/NTX/mV enabled)
Sample Duration Time	175ms
Open Circuit Detection Time	Within 5s
Maximum Ratings	-0.3 V to +5.3 V, <15mA
Common Mode Range	-0.3 V to +5.3 V
Common Mode Rejection	100dB@DC, 130dB@60Hz
Conversion Method	Sigma-Delta, 24-bit

Thermocouple Parameters

Thermocouple Input Ranges	Type J: -210 $^{\circ}$ to 1200 $^{\circ}$ C (-346 $^{\circ}$ to 2192 $^{\circ}$ F) Type K: -265 $^{\circ}$ to 1372 $^{\circ}$ C (-445 $^{\circ}$ to 2502 $^{\circ}$ F) Type E: -265 $^{\circ}$ to 1000 $^{\circ}$ C (-445 $^{\circ}$ to 1832 $^{\circ}$ F) Type N: -265 $^{\circ}$ to 1300 $^{\circ}$ C (-445 $^{\circ}$ to 2372 $^{\circ}$ F) Type R: -50 $^{\circ}$ to 1768 $^{\circ}$ C (-58 $^{\circ}$ to 3214 $^{\circ}$ F) Type S: -50 $^{\circ}$ to 1768 $^{\circ}$ C (-58 $^{\circ}$ to 3214 $^{\circ}$ F) Type B: 40 $^{\circ}$ to 1820 $^{\circ}$ C (104 $^{\circ}$ to 3308 $^{\circ}$ F) Type T: -265 $^{\circ}$ to 400 $^{\circ}$ C (-445 $^{\circ}$ to 752 $^{\circ}$ F)
Linear Voltage Input Ranges	-31.25 to 31.25 mVDC -31.25 to 125mVDC -31.25 to 62.5 mVDC 0 to 1.0 VDC
Cold Junction Compensation	Automatic
Thermocouple Linearization	Automatic
Maximum Inaccuracy–Thermocouple	$\pm(0.2^{\circ}\text{C} + 3\% \text{ of } ^{\circ}\text{C} \text{ reading})$
Maximum Inaccuracy–Voltage	$\pm 250\mu\text{V}$

RTD/Thermistor Parameters

Input Ranges (RTD Types)	10, 50, 100, 200, 500, 1000 Ω Pt Platinum RTD 0.00385 European Curve: -200 $^{\circ}$ to 850 $^{\circ}$ C (-328 $^{\circ}$ to 1562 $^{\circ}$ F) 120 Ω Ni N120 Nickel RTD 0.00672 Curve: -80 $^{\circ}$ to 260 $^{\circ}$ C (-112 $^{\circ}$ to 500 $^{\circ}$ F)
Thermistor Input Ranges	2.252 k Ω @ 25 $^{\circ}$ C: -40 $^{\circ}$ to 150 $^{\circ}$ C (-40 $^{\circ}$ to 302 $^{\circ}$ F) 3 k Ω @ 25 $^{\circ}$ C: -40 $^{\circ}$ to 150 $^{\circ}$ C (-40 $^{\circ}$ to 302 $^{\circ}$ F) 5 k Ω @ 25 $^{\circ}$ C: -40 $^{\circ}$ to 150 $^{\circ}$ C (-40 $^{\circ}$ to 302 $^{\circ}$ F) 10k-AN Type 3 @ 25 $^{\circ}$ C: -40 $^{\circ}$ to 150 $^{\circ}$ C (-40 $^{\circ}$ to 302 $^{\circ}$ F) 30 k Ω @ 25 $^{\circ}$ C: -40 $^{\circ}$ to 150 $^{\circ}$ C (-40 $^{\circ}$ to 302 $^{\circ}$ F)
RTD Excitation Current	RTD 10, 100, 120, 200: 1mA RTD 500: 500 μ A RTD 1000: 250 μ A
Thermistor Excitation Current	NTC 2.252k, NTC 3k: 10 μ A NTC 5k, NTC 10k: 5 μ A NTC 30k: 1 μ A
RTD/Thermistor Linearization	Automatic
Maximum Inaccuracy	$\pm 0.2^{\circ}\text{C}$

BX-4UT4DA-3 Universal Temp Input/Analog Output, continued

Analog Universal Current/Voltage Sinking Output Specifications	
BX-4UT4DA-3	
Outputs per Module	4
Commons	1
Module Signal Output Range	0–20mA, 4–20mA, ± 20 mA, ± 10 VDC, ± 5 VDC, 0–5 VDC (Default), 0–10 VDC
Signal Resolution	16-bit at ± 10 V or ± 20 mA
Resolution Value of LSB	See Data Range Specifications table
Output Type	Current Sinking/Sourcing up to 5V Voltage outputs sourcing/sinking at 10mA (example 10V @ 1k Ω load).
Output Value in Fault Mode	Current outputs ~ 0 mA Voltage outputs 0V (Unipolar or Bipolar)
Minimum Voltage Load Impedance	1k Ω
Maximum Current Load Impedance	250 Ω
Allowed Load Type	Grounded
Maximum Continuous Overload	Indefinitely
All Channel Update Rate	1.0 ms
Maximum Inaccuracy	$\pm 0.1\%$ of HW full scale (65 counts)
Maximum Full Scale Calibration Error	$\pm 0.1\%$ of HW full scale (65 counts)
Conversion Method	Amplified Divide-by-2 Resistor String
Linearity Error (end to end)	$\pm 0.1\%$ of HW full scale (65 counts)
Output Stability and Repeatability	$\pm 0.02\%$ of full range (12 counts) after 10 min. warmup (typical)
Output Settling Time	10 μ s
Channel to Backplane Isolation	1800VAC applied for one second
Channel to Channel Isolation	None
Loop Fusing (External)	Fast-acting 0.032A recommended

Module General Specifications	
Weight	98g (3.5 oz)
Heat Dissipation	2.5 W
Backplane Power Consumption	2.65 W
Agency Approvals	UL 61010-2 File E185989, Canada and USA
Software Version Required	Do-more! Designer 2.7 or later

BX-4UT4DA-3 Universal Temp Input/Analog Output, continued

Data Range Specifications			
Thermocouple Selection	Temperature Range	Resolution	
		WXn	RXn
Type J	-210 to 1200 °C -346 to 2192 °F	Degrees x10 (One Implied Decimal) ¹	24-Bit Floating ¹
Type K	-265 to 1372 °C -445 to 2502 °F		
Type E	-265 to 1000 °C -445 to 1832 °F		
Type R	-50 to 1768 °C -58 to 3214 °F		
Type S	-50 to 1768 °C -58 to 3214 °F		
Type B	40 to 1820 °C 104 to 3308 °F ³		
Type T	-265 to 400 °C -445 to 752 °F		
Voltage Selection	Voltage Range	WXn ²	RXn
-31.25 to 31.25 mVDC	Bipolar 31.25 mVDC	0.95 μ V per count (-32768 to 32767)	User Scaled
-31.25 to 62.5 mVDC	Bipolar 62.5 mVDC	1.9 μ V per count (-16384 to 32767)	
-31.25 to 125 mVDC	Bipolar 125 mVDC	3.8 μ V per count (-8192 to 32767)	
0 to 1.0 VDC	Unipolar 1.0 VDC	30.5 μ V per count (0 to 32767)	
RTD Selection	Temperature Range	WXn	RXn
10, 50, 100, 200, 500, 1000 Ω Pt Platinum RTD 0.00385 European Curve	-200 to 850 °C -328 to 1562 °F	Degrees x10 (One Implied Decimal) ¹	24-Bit Floating ¹
120 Ω Ni N120 Nickel RTD 0.00672 Curve	-80 to 260 °C -112 to 500 °F		
Thermistor Selection	Temperature Range	WXn	RXn
Thermistor 2.252 k Ω @25°C	-40 to 150 °C -40 to 302 °F	Degrees x10 (One Implied Decimal) ¹	24-Bit Floating ¹
Thermistor 3k Ω @25°C			
Thermistor 5k Ω @25°C			
Thermistor 10k-AN Type 3 @25°C			
Thermistor 30k Ω @25°C			

1. Temperatures reported in rounded integer to WXn and as scaled floating point 24bits resolution to RXn.

2. Raw Counts = -32768 to 32767.

3. Max value displayed in WXn is 32767. RXn will display the full range of 3308.0.

The module reserves the first 8 bits of unused contiguous space in the X register, aligned to an 8-bit word boundary, for status reporting. Error flags for this module are laid out within its status register space as described in the table below.

Error Flag Specifications								
	MSB							LSB
1st Byte of unused X Registers								
Module Status	Channel 4 Burnout	Channel 4 Out of Range	Channel 3 Burnout	Channel 3 Out of Range	Channel 2 Burnout	Channel 2 Out of Range	Channel 1 Burnout	Channel 1 Out of Range

BX-4UT4DA-3 Universal Temp Input/Analog Output, continued

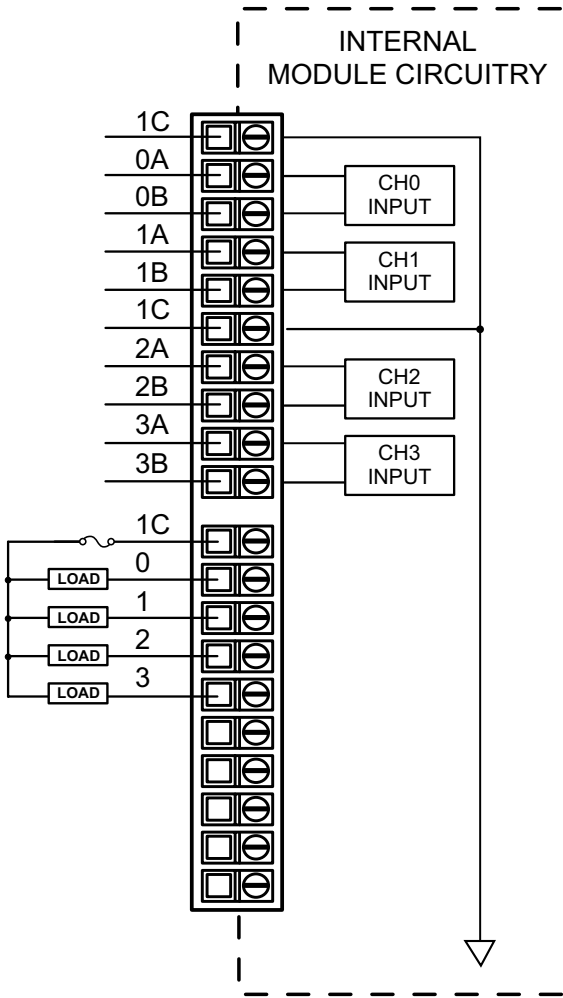

Analog Current Source Output Circuit

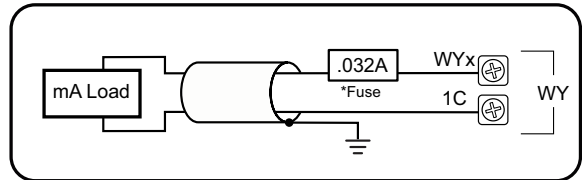

Analog Voltage Output Circuit

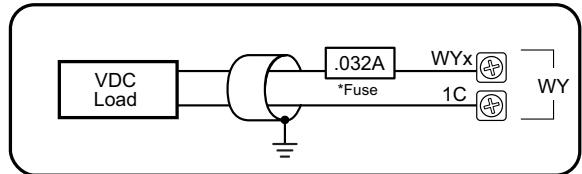

NOTE: Shield should be connected only at one end, to ground at the source device.

*An Edison S500-32-R 0.032A fast-acting fuse is recommended for all analog voltage inputs, analog outputs, and current loops.

Resistive and Thermistor Sensors

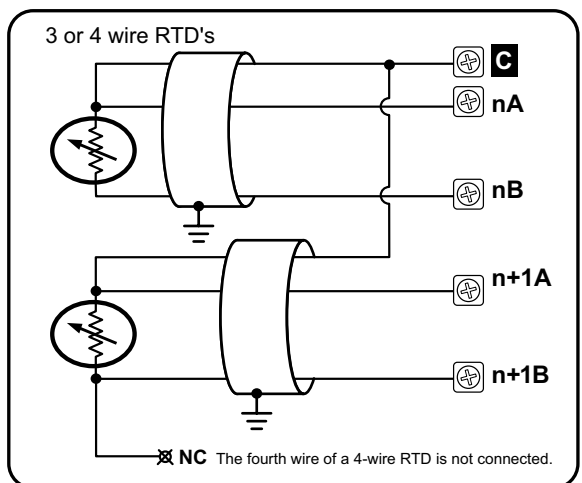
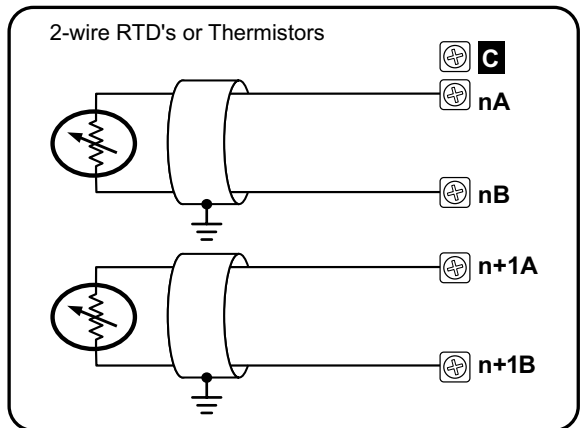

BX-4UT4DA-3 Universal Temp Input/Analog Output, continued

Thermocouple and Voltage Sensors

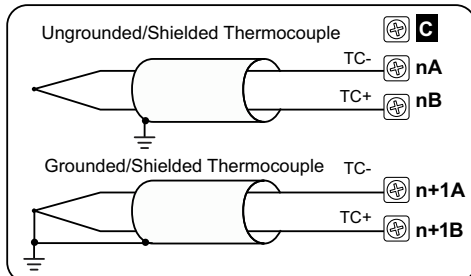

NOTE: Thermocouple extension wire and proper thermocouple terminal blocks must be used to extend thermocouples. AutomationDirect thermocouple wire is recommended.

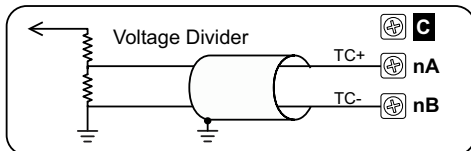
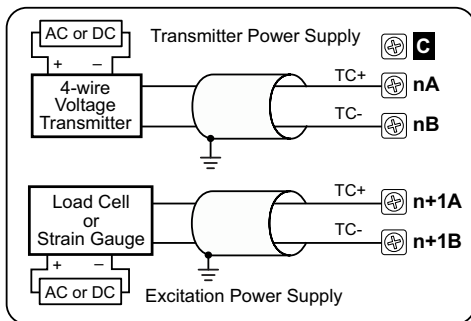

NOTE: Shield should be connected only at one end, to ground at the source device. For maximum accuracy: Jumper unused inputs.



Mixed Resistive and Thermocouple Sensors

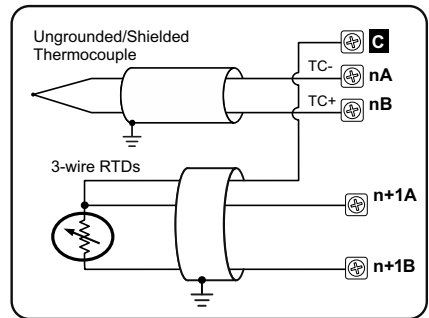
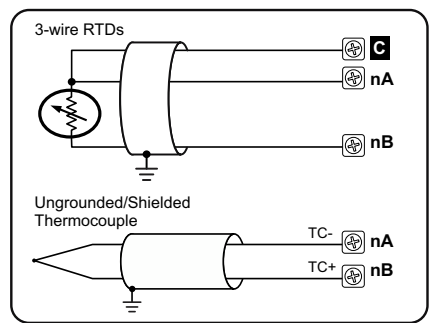

Notes for maximum accuracy:

1. All wires to an RTD must be equal length and type. Refer to RTD manufacturer's recommendations.
2. Do not use cable shield as sensing wire.
3. When applicable, connect shield to RTD common only, otherwise connect to module common only. Do not connect shield to both ends.
4. Jumper unused inputs.



NOTE: With grounded thermocouples, take precautions to prevent having a voltage potential between thermocouple tips. A voltage of 1.25 V or greater between tips will skew measurements.

BX-4UT4DA-3 Universal Temp Input/Analog Output, continued

Software Setup

After the module is installed, open the Do-more! Designer programming software, connect to the BRX MPU and open the **Configure Module** dialog as described at the beginning of this chapter.

Setup BX-4UT4DA-3 Module

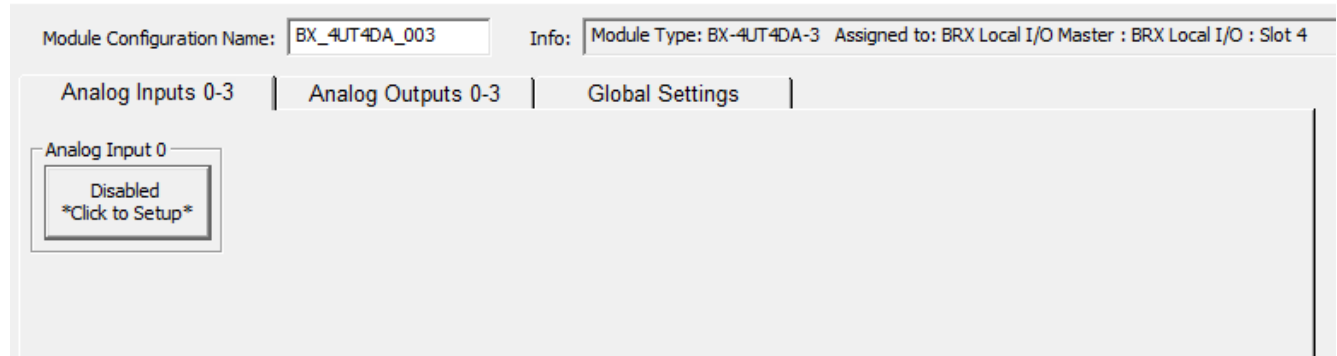

1. *Analog Input x*

Button – Click the button to set up the channel.

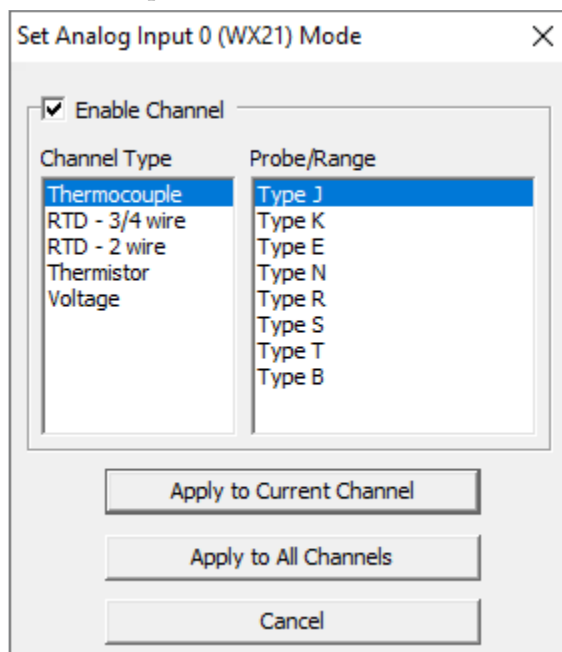

2. Set *Analog Input x*

Enable Channel – Check the box to enable this channel.

Channel Type – Select the type of device for this channel. This can be different for each channel.

Probe/Range – Select the style of device for this channel.

Apply to Current Channel – Apply these settings to just this one channel.

Apply to All Channels – Apply these settings to every channel on the card.

Cancel – Make no changes and leave this dialog.

BX-4UT4DA-3 Universal Temp Input/Analog Output, continued

Setup BX-4UT4DA-3 Module

Module Configuration Name: Info:

Analog Inputs 0-3 | Analog Outputs 0-3 | Global Settings

Analog Input 0

Thermocouple Type J

Filter Time:
Time is in seconds. Enter 0 to disable.

WX17
Range: -346 - 2192
Units/Ct: 1DegF
Out of Range: X40
Burn Out: X41

RX17
Range: -346.00 - 2192.00

3. *WXx*

Range – The temperature in whole degrees for the selected channel on the module.

Units/Ct – The amount of temperature change that will equal 1 raw count.

Out of Range – The input register that, when On, will indicate that the input is outside of the range selected.

Burn Out – If burn out is enabled, this register will be On when the loop is broken.

4. *RXx*

Range – The floating point value of the channel temperature.

Setup BX-4UT4DA-3 Module

Module Configuration Name: Info:

Analog Inputs 0-3 | Analog Outputs 0-3 | Global Settings

Analog Output 0

WY9
Range: 0 - 32767
Resolution: 15 bits
Units/Ct: 153uV

RX9
Range: 0.00 - 100.00
Units/Ct: 0.001526

Enable Scaling from RY9 to WY9

RY9 Min — WY9 Min
RY9 Max — WY9 Max

Clamp WY9

5. *Analog Output x*

These settings are for each channel of the analog module.

Drop-down menu - Select the range of the analog input here.

6. *WXx*

Range – The number of Raw counts for the selected channel on the module.

Units/Ct – The amount of current that will equal 1 raw count.

7. *RXx*

Range – The engineering units to which the raw counts are scaled.

Units/Ct – The number of raw counts that will equal 1 scaled engineering unit.

BX-4UT4DA-3 Universal Temp Input/Analog Output, continued

8. *Enable Scaling from WYx to RYx*

RYx Min – The minimum value of the engineering units for scaling.

RYx Max – The maximum value of the engineering units for scaling.

WYx Min – The minimum value of the raw counts to scale.

WYx Max – The maximum value of the raw counts to scale.

Counts/VDC – Use these buttons to change the raw scaling to counts or milliamps.

Clamp WYx – If this box is checked, WYx will clamp at the minimum and maximum scaled values.

Setup BX-4UT4DA-3 Module

Module Configuration Name: Info:

Analog Inputs 0-3 | Analog Outputs 0-3 | **Global Settings**

Global Settings

Temperature Scale

Fahrenheit (Deg F)

Celsius (Deg C)

A/C Rejection

50/60Hz @75dB

60Hz @120dB

50Hz @120dB

9. *Temperature Scale*

Select Fahrenheit or Celsius.

10. *A/C Rejection*

The rejection range for the common mode rejection. This is typically set to the AC line frequency at the installation.

BX-4UT4TD1 Universal Temperature Input/ DC Sinking Output

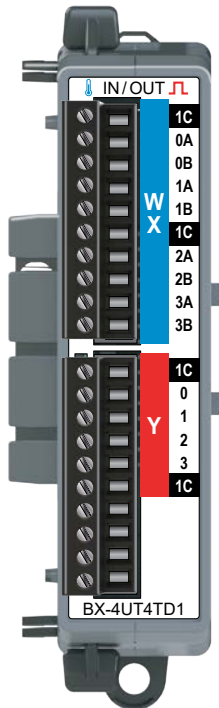

BX-4UT4TD1

Universal Temperature Input/
DC Sinking Output Expansion Module
4-pt Universal Temperature Input
4-pt DC Sinking Output

BX-RTB10 Terminal Blocks Included.
The BX-RTB10-1 or BX-RTB10-2 can also be used and can be purchased separately.



NOTE: This device does not support ZIPLink Wiring Systems.

IMPORTANT!



Hot-Swapping Information

Note: This device cannot be Hot Swapped.

Universal Temperature Input Specifications

	BX-4UT4TD1
Input Channels	4 Differential
Commons	1
Input Impedance	>5MΩ
Resolution	24-bit, 0.1°(C or F) See Data Range Specifications table
All Channel Update Rate	1s max (4 thermocouples enabled) 700ms max (4RTD/NTX/mV enabled)
Sample Duration Time	175ms
Open Circuit Detection Time	Within 5s
Maximum Ratings	-0.3 V to +5.3 V, <15mA
Common Mode Range	-0.3 V to +5.3 V
Common Mode Rejection	100dB@DC, 130dB@60Hz
Conversion Method	Sigma-Delta, 24-bit
Thermocouple Parameters	
Thermocouple Input Ranges	Type J: -210° to 1200°C (-346° to 2192°F) Type K: -265° to 1372°C (-445° to 2502°F) Type E: -265° to 1000°C (-445° to 1832°F) Type N: -265° to 1300°C (-445° to 2372°F) Type R: -50° to 1768°C (-58° to 3214°F) Type S: -50° to 1768°C (-58° to 3214°F) Type B: 40° to 1820°C (104° to 3308°F) Type T: -265° to 400°C (-445° to 752°F)
Linear Voltage Input Ranges	-31.25 to 31.25 mVDC -31.25 to 125mVDC -31.25 to 62.5 mVDC 0 to 1.0 VDC
Cold Junction Compensation	Automatic
Thermocouple Linearization	Automatic
Maximum Inaccuracy–Thermocouple	±(0.2°C + 3% of °C reading)
Maximum Inaccuracy–Voltage	±250μV
RTD/Thermistor Parameters	
Input Ranges (RTD Types)	10, 50, 100, 200, 500, 1000Ω Pt Platinum RTD 0.00385 European Curve: -200° to 850°C (-328° to 1562°F) 120Ω Ni N120 Nickel RTD 0.00672 Curve: -80° to 260°C (-112° to 500°F)
Thermistor Input Ranges	2.252 kΩ @ 25°C: -40° to 150°C (-40° to 302°F) 3 kΩ @ 25°C: -40° to 150°C (-40° to 302°F) 5 kΩ @ 25°C: -40° to 150°C (-40° to 302°F) 10k-AN Type 3 @ 25°C: -40° to 150°C (-40° to 302°F) 30 kΩ @ 25°C: -40° to 150°C (-40° to 302°F)
Thermistor Excitation Current	NTC 2.252k, NTC 3k: 10μA NTC 5k, NTC 10k: 5μA NTC 30k: 1μA
RTD Excitation Current	RTD 10, 100, 120, 200: 1mA RTD 500: 500μA RTD 1000: 250μA
RTD/Thermistor Linearization	Automatic
Maximum Inaccuracy	±0.2°C

BX-4UT4TD1 Universal Temperature Input/ DC Sinking Output, continued

Voltage Sinking Output Specifications	
	BX-4UT4TD1
Outputs per Module	4
Commons	1
Output Type	Sinking
Maximum Current per Common	2A
Nominal Voltage	12–24VDC
Operating Voltage Range	5–36VDC
Peak Voltage	36VDC
Minimum Output Current	0.1 mA @ 24VDC
Maximum Output Current	0.5 A per output, no derating over temperature range
Maximum Inrush Current	5A for 50ms
Maximum Leakage Current	10 μ A
ON Voltage Drop	0.05 VDC
Fuses, Overcurrent Protection	N/A
OFF-ON Response	<5ms
ON-OFF Response	<2ms
Status Indicators	Logic Side, Green

Module General Specifications	
Weight	98g (3.5 oz)
Heat Dissipation	2.5 W
Backplane Power Consumption	2.5 W
Agency Approvals	UL 61010-2 File E185989, Canada and USA
Software Version Required	Do-more! Designer 2.7 or later

BX-4UT4TD1 Universal Temperature Input/ DC Sinking Output, continued

Data Range Specifications			
Thermocouple Selection	Temperature Range	Resolution	
		WXn	RXn
Type J	-210 to 1200 °C -346 to 2192 °F	Degrees x10 (One Implied Decimal) ¹	24-Bit Floating ¹
Type K	-265 to 1372 °C -445 to 2502 °F		
Type E	-265 to 1000 °C -445 to 1832 °F		
Type R	-50 to 1768 °C -58 to 3214 °F		
Type S	-50 to 1768 °C -58 to 3214 °F		
Type B	40 to 1820 °C 104 to 3308 °F ³		
Type T	-265 to 400 °C -445 to 752 °F		
Voltage Selection	Voltage Range	WXn ²	RXn
-31.25 to 31.25 mVDC	Bipolar 31.25 mVDC	0.95 μ V per count (-32768 to 32767)	User Scaled
-31.25 to 62.5 mVDC	Bipolar 62.5 mVDC	1.9 μ V per count (-16384 to 32767)	
-31.25 to 125 mVDC	Bipolar 125 mVDC	3.8 μ V per count (-8192 to 32767)	
0 to 1.0 VDC	Unipolar 1.0 VDC	30.5 μ V per count (0 to 32767)	
RTD Selection	Temperature Range	WXn	RXn
10, 50, 100, 200, 500, 1000 Ω Pt Platinum RTD 0.00385 European Curve	-200 to 850 °C -328 to 1562 °F	Degrees x10 (One Implied Decimal) ¹	24-Bit Floating ¹
120 Ω Ni N120 Nickel RTD 0.00672 Curve	-80 to 260 °C -112 to 500 °F		
Thermistor Selection	Temperature Range	WXn	RXn
Thermistor 2.252 k Ω @25°C	-40 to 150 °C -40 to 302 °F	Degrees x10 (One Implied Decimal) ¹	24-Bit Floating ¹
Thermistor 3k Ω @25°C			
Thermistor 5k Ω @25°C			
Thermistor 10k-AN Type 3 @25°C			
Thermistor 30k Ω @25°C			

1. Temperatures reported in rounded integer to WXn and as scaled floating point 24bits resolution to RXn.

2. Raw Counts = -32768 to 32767.

3. Max value displayed in WXn is 32767. RXn will display the full range of 3308.0.

The module reserves the first 8 bits of unused contiguous space in the X register, aligned to an 8-bit word boundary, for status reporting. Error flags for this module are laid out within its status register space as described in the table below.

Error Flag Specifications								
	MSB							LSB
1st Byte of unused X Registers								
Module Status	Channel 4 Burnout	Channel 4 Out of Range	Channel 3 Burnout	Channel 3 Out of Range	Channel 2 Burnout	Channel 2 Out of Range	Channel 1 Burnout	Channel 1 Out of Range

BX-4UT4TD1 Universal Temperature Input/ DC Sinking Output, continued

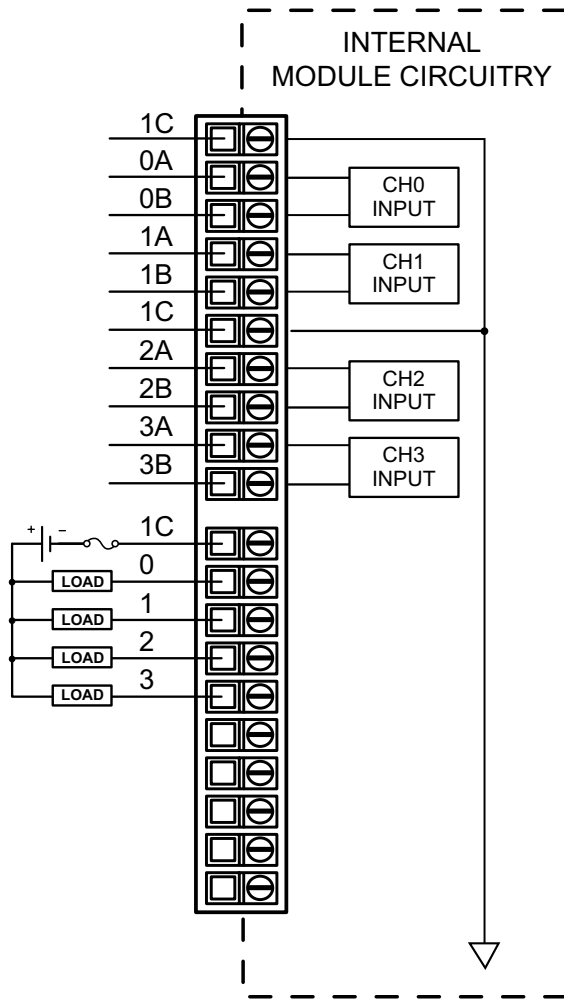

Sinking Output

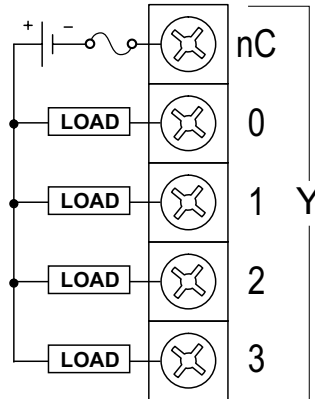

Resistive and Thermistor Sensors

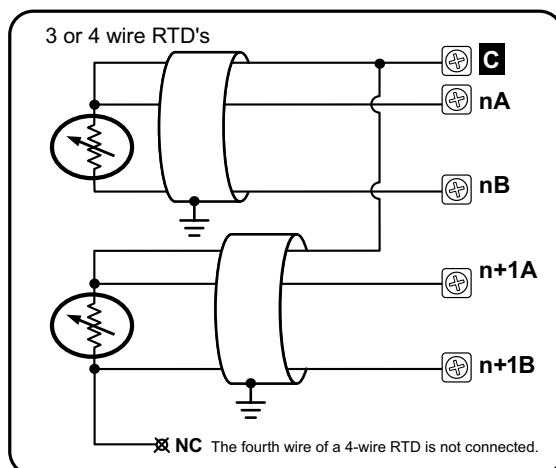
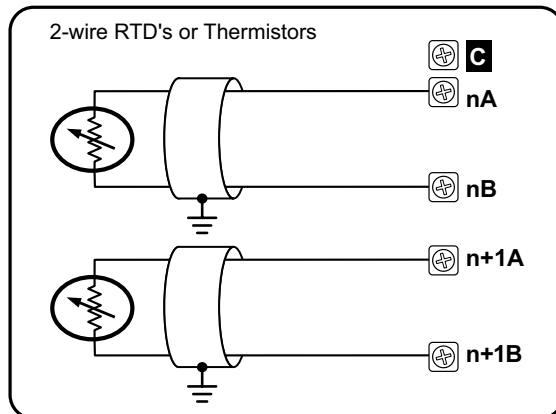

BX-4UT4TD1 Universal Temperature Input/ DC Sinking Output, continued

Mixed Resistive and Thermocouple Sensors

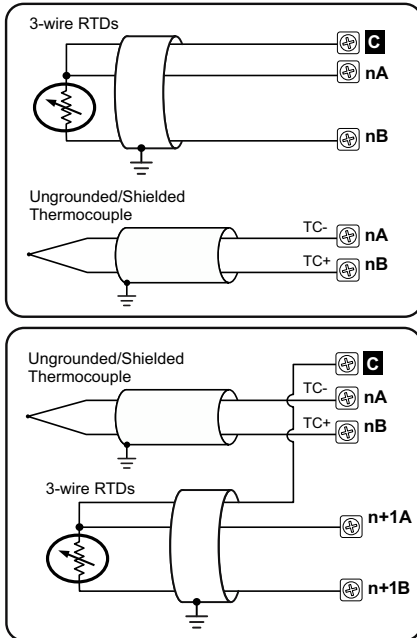

Notes for maximum accuracy:

1. All wires to an RTD must be equal length and type. Refer to RTD manufacturer's recommendations.
2. Do not use cable shield as sensing wire.
3. When applicable, connect shield to RTD common only, otherwise connect to module common only. Do not connect shield to both ends.
4. Jumper unused inputs.

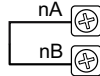

Thermocouple and Voltage Sensors

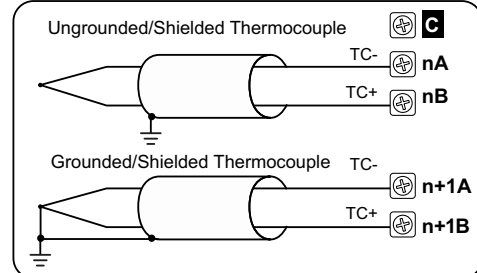

NOTE: Thermocouple extension wire and proper thermocouple terminal blocks must be used to extend thermocouples. AutomationDirect thermocouple wire is recommended.

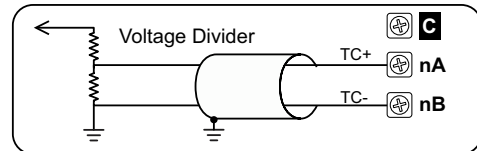
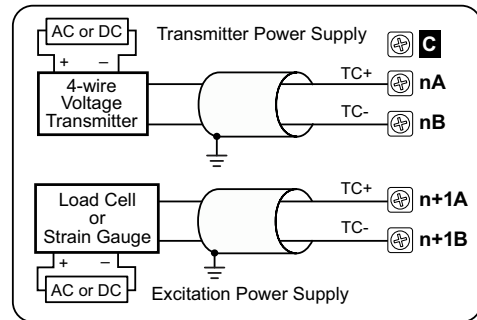

NOTE: Shield should be connected only at one end, to ground at the source device. For maximum accuracy: Jumper unused inputs.



NOTE: With grounded thermocouples, take precautions to prevent having a voltage potential between thermocouple tips. A voltage of 1.25 V or greater between tips will skew measurements.

BX-4UT4TD1 Universal Temperature Input/ DC Sinking Output, continued

Software Setup

After the module is installed, open the Do-more! Designer programming software, connect to the BRX MPU and open the **Configure Module** dialog as described at the beginning of this chapter.

Setup BX-4UT4TD1 Module



1. *Analog Input x*

Button – Click the button to set up the channel.

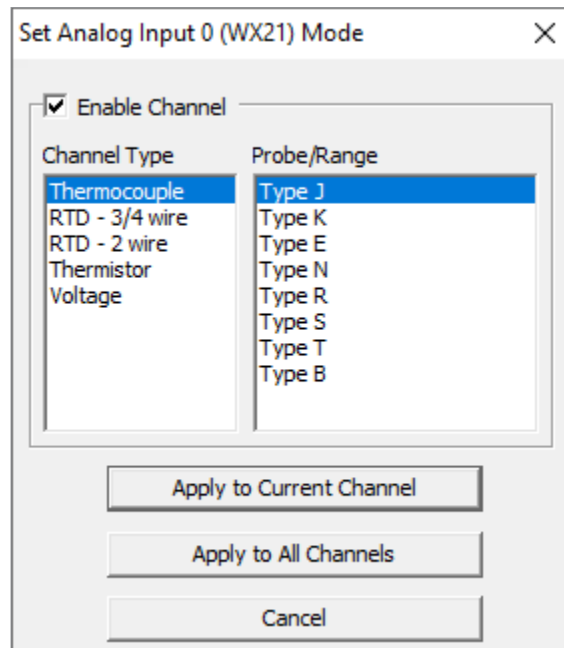

2. Set *Analog Input x*

Enable Channel – Check the box to enable this channel.

Channel Type – Select the type of device for this channel. This can be different for each channel.

Probe/Range – Select the style of device for this channel.

Apply to Current Channel – Apply these settings to just this one channel.

Apply to All Channels – Apply these settings to every channel on the card.

Cancel – Make no changes and leave this dialog.

BX-4UT4TD1 Universal Temperature Input/ DC Sinking Output, continued

Setup BX-4UT4TD1 Module

Module Configuration Name: Info:

Analog Inputs 0-3 | Global Settings

Analog Input 0

Thermocouple Type J

Filter Time: Time is in seconds. Enter 0 to disable.

WX21

Range: -346 - 2192

Units/Ct: 1DegF

Out of Range: X48

Burn Out: X49

RX21

Range: -346.00 - 2192.00

3. *WXx*

Range – The temperature in whole degrees for the selected channel on the module.

Units/Ct – The amount of temperature change that will equal 1 raw count.

Out of Range – The input register that, when On, will indicate that the input is outside of the range selected.

Burn Out – If burn out is enabled, this register will be On when the loop is broken.

4. *RXx*

Range – The floating point value of the channel temperature.

Setup BX-4UT4TD1 Module

Module Configuration Name: Info:

Analog Inputs 0-3 | Global Settings

Global Settings

Temperature Scale

Fahrenheit (Deg F)

Celsius (Deg C)

A/C Rejection

50/60Hz @75dB

60Hz @120dB

50Hz @120dB

5. *Temperature Scale*

Select Fahrenheit or Celsius.

6. *A/C Rejection*

The rejection range for the common mode rejection. This is typically set to the AC line frequency at the installation.

BX-4UT4TD2 Universal Temperature Input/ DC Sourcing Output

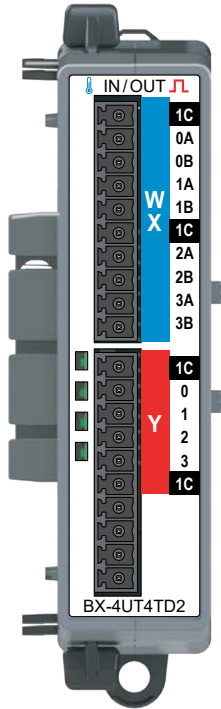

BX-4UT4TD2

Universal Temperature Input/
DC Sourcing Output Expansion Module
4-pt Universal Temperature Input
4-pt DC Sourcing Output

BX-RTB10 Terminal Blocks Included.
The BX-RTB10-1 or BX-RTB10-2 can also be used and can be purchased separately.

NOTE: This device does not support ZIPLink Wiring Systems.

IMPORTANT!



Hot-Swapping Information
Note: This device cannot be Hot Swapped.

Universal Temperature Input Specifications	
BX-4UT4TD2	
Input Channels	4 Differential
Commons	1
Input Impedance	>5MΩ
Resolution	24-bit, 0.1°(C or F) See Data Range Specifications table
All Channel Update Rate	1s max (4 thermocouples enabled) 700ms max (4RTD/NTX/mV enabled)
Sample Duration Time	175ms
Open Circuit Detection Time	Within 5s
Maximum Ratings	-0.3 V to +5.3 V, <15mA
Common Mode Range	-0.3 V to +5.3 V
Common Mode Rejection	100dB@DC, 130dB@60Hz
Conversion Method	Sigma-Delta, 24-bit
Thermocouple Parameters	
Thermocouple Input Ranges	Type J: -210° to 1200°C (-346° to 2192°F) Type K: -265° to 1372°C (-445° to 2502°F) Type E: -265° to 1000°C (-445° to 1832°F) Type N: -265° to 1300°C (-445° to 2372°F) Type R: -50° to 1768°C (-58° to 3214°F) Type S: -50° to 1768°C (-58° to 3214°F) Type B: 40° to 1820°C (104° to 3308°F) Type T: -265° to 400°C (-445° to 752°F)
Linear Voltage Input Ranges	-31.25 to 31.25 mVDC -31.25 to 125mVDC -31.25 to 62.5 mVDC 0 to 1.0 VDC
Cold Junction Compensation	Automatic
Thermocouple Linearization	Automatic
Maximum Inaccuracy–Thermocouple	±(0.2°C + 3% of °C reading)
Maximum Inaccuracy–Voltage	±250μV
RTD/Thermistor Parameters	
Input Ranges (RTD Types)	10, 50, 100, 200, 500, 1000Ω Pt Platinum RTD 0.00385 European Curve: -200° to 850°C (-328° to 1562°F) 120Ω Ni N120 Nickel RTD 0.00672 Curve: -80° to 260°C (-112° to 500°F)
Thermistor Input Ranges	2.252 kΩ @ 25°C: -40° to 150°C (-40° to 302°F) 3 kΩ @ 25°C: -40° to 150°C (-40° to 302°F) 5 kΩ @ 25°C: -40° to 150°C (-40° to 302°F) 10k-AN Type 3 @ 25°C: -40° to 150°C (-40° to 302°F) 30 kΩ @ 25°C: -40° to 150°C (-40° to 302°F)
Thermistor Excitation Current	NTC 2.252k, NTC 3k: 10μA NTC 5k, NTC 10k: 5μA NTC 30k: 1μA
RTD Excitation Current	RTD 10, 100, 120, 200: 1mA RTD 500: 500μA RTD 1000: 250μA
RTD/Thermistor Linearization	Automatic
Maximum Inaccuracy	±0.2°C

BX-4UT4TD2 Universal Temperature Input/ DC Sourcing Output, continued

Voltage Sourcing Output Specifications	
	BX-4UT4TD2
Outputs per Module	4
Commons	1
Output Type	Sourcing
Maximum Current per Common	2A
Nominal Voltage	12–24VDC
Operating Voltage Range	5–36VDC
Peak Voltage	36VDC
Minimum Output Current	0.1 mA @ 24VDC
Maximum Output Current	0.5 A per output, no derating over temperature range
Maximum Inrush Current	5A for 50ms
Maximum Leakage Current	10 μ A
ON Voltage Drop	0.05 VDC
Fuses, Overcurrent Protection	N/A
OFF-ON Response	<5ms
ON-OFF Response	<2ms
Status Indicators	Logic Side, Green

Module General Specifications	
Weight	98g (3.5 oz)
Heat Dissipation	2.3 W
Backplane Power Consumption	2.5 W
Agency Approvals	UL 61010-2 File E185989, Canada and USA
Software Version Required	Do-more! Designer 2.7 or later

BX-4UT4TD2 Universal Temperature Input/ DC Sourcing Output, continued

Data Range Specifications			
Thermocouple Selection	Temperature Range	Resolution	
		WXn	RXn
Type J	-210 to 1200 °C -346 to 2192 °F	Degrees x10 (One Implied Decimal) ¹	24-Bit Floating ¹
Type K	-265 to 1372 °C -445 to 2502 °F		
Type E	-265 to 1000 °C -445 to 1832 °F		
Type R	-50 to 1768 °C -58 to 3214 °F		
Type S	-50 to 1768 °C -58 to 3214 °F		
Type B	40 to 1820 °C 104 to 3308 °F ³		
Type T	-265 to 400 °C -445 to 752 °F		
Voltage Selection	Voltage Range	WXn ²	RXn
-31.25 to 31.25 mVDC	Bipolar 31.25 mVDC	0.95 µV per count (-32768 to 32767)	User Scaled
-31.25 to 62.5 mVDC	Bipolar 62.5 mVDC	1.9 µV per count (-16384 to 32767)	
-31.25 to 125 mVDC	Bipolar 125 mVDC	3.8 µV per count (-8192 to 32767)	
0 to 1.0 VDC	Unipolar 1.0 VDC	30.5 µV per count (0 to 32767)	
RTD Selection	Temperature Range	WXn	RXn
10, 50, 100, 200, 500, 1000Ω Pt Platinum RTD 0.00385 European Curve	-200 to 850 °C -328 to 1562 °F	Degrees x10 (One Implied Decimal) ¹	24-Bit Floating ¹
120Ω Ni N120 Nickel RTD 0.00672 Curve	-80 to 260 °C -112 to 500 °F		
Thermistor Selection	Temperature Range	WXn	RXn
Thermistor 2.252 kΩ @25°C	-40 to 150 °C -40 to 302 °F	Degrees x10 (One Implied Decimal) ¹	24-Bit Floating ¹
Thermistor 3kΩ @25°C			
Thermistor 5kΩ @25°C			
Thermistor 10k-AN Type 3 @25°C			
Thermistor 30kΩ @25°C			

1. Temperatures reported in rounded integer to WXn and as scaled floating point 24bits resolution to RXn.

2. Raw Counts = -32768 to 32767.

3. Max value displayed in WXn is 32767. RXn will display the full range of 3308.0.

The module reserves the first 8 bits of unused contiguous space in the X register, aligned to an 8-bit word boundary, for status reporting. Error flags for this module are laid out within its status register space as described in the table below.

Error Flag Specifications								
	MSB							LSB
1st Byte of unused X Registers								
Module Status	Channel 4 Burnout	Channel 4 Out of Range	Channel 3 Burnout	Channel 3 Out of Range	Channel 2 Burnout	Channel 2 Out of Range	Channel 1 Burnout	Channel 1 Out of Range

BX-4UT4TD2 Universal Temperature Input/ DC Sourcing Output, continued

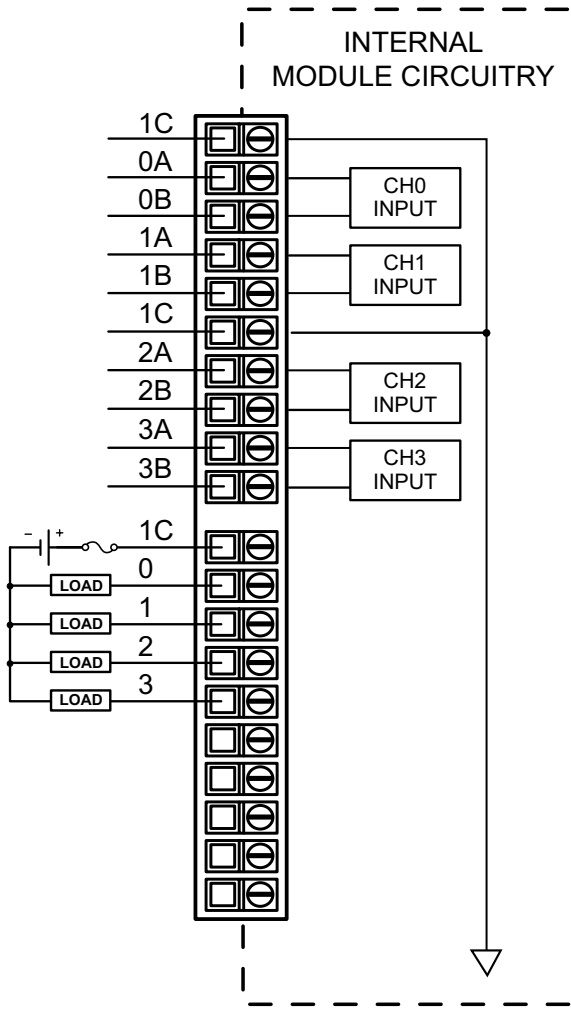

Sourcing Output

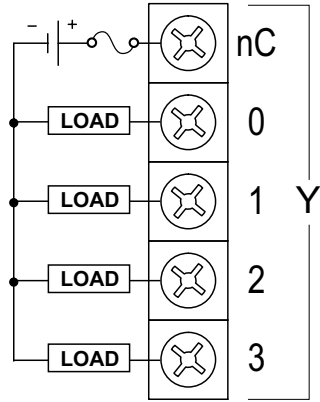

Resistive and Thermistor Sensors

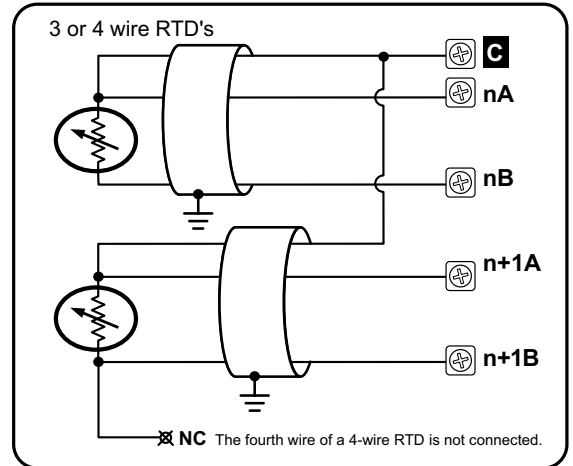
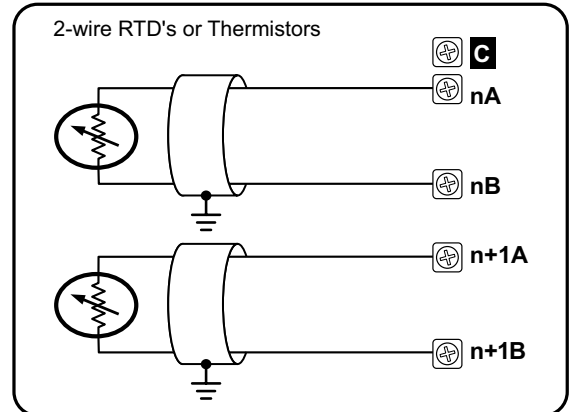

BX-4UT4TD2 Universal Temperature Input/ DC Sourcing Output, continued

Mixed Resistive and Thermocouple Sensors

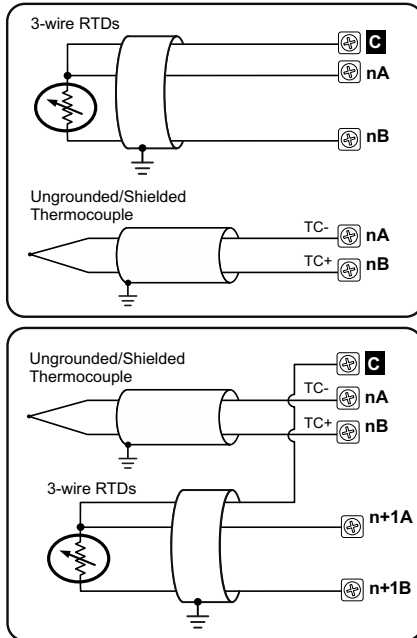

Notes for maximum accuracy:

1. All wires to an RTD must be equal length and type. Refer to RTD manufacturer's recommendations.
2. Do not use cable shield as sensing wire.
3. When applicable, connect shield to RTD common only, otherwise connect to module common only. Do not connect shield to both ends.
4. Jumper unused inputs.



Thermocouple and Voltage Sensors

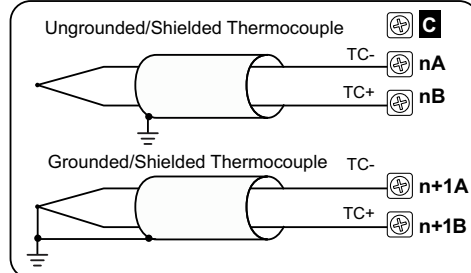

NOTE: Thermocouple extension wire and proper thermocouple terminal blocks must be used to extend thermocouples. AutomationDirect thermocouple wire is recommended.

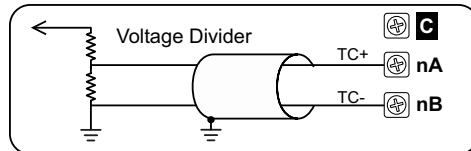
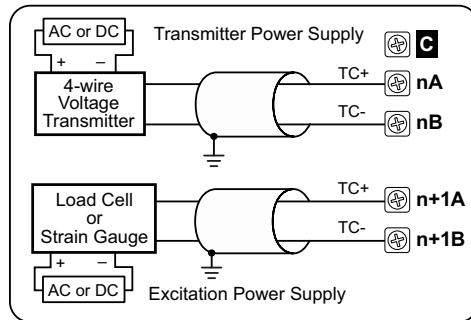

NOTE: Shield should be connected only at one end, to ground at the source device. For maximum accuracy: Jumper unused inputs. TC+ nA TC- nB



NOTE: With grounded thermocouples, take precautions to prevent having a voltage potential between thermocouple tips. A voltage of 1.25 V or greater between tips will skew measurements.

BX-4UT4TD2 Universal Temperature Input/ DC Sourcing Output, continued

Software Setup

After the module is installed, open the Do-more! Designer programming software, connect to the BRX MPU and open the **Configure Module** dialog as described at the beginning of this chapter.

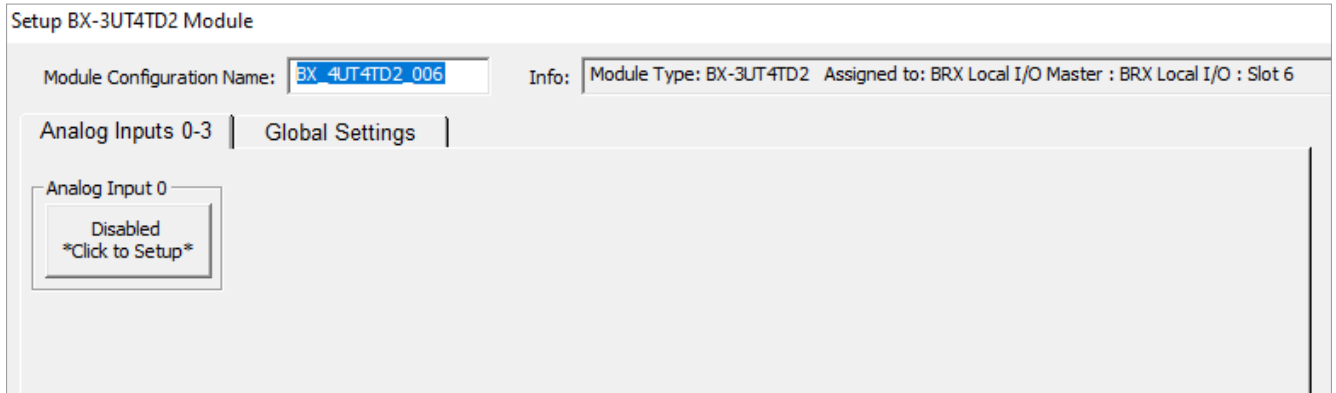

1. *Analog Input x*

Button – Click the button to set up the channel.

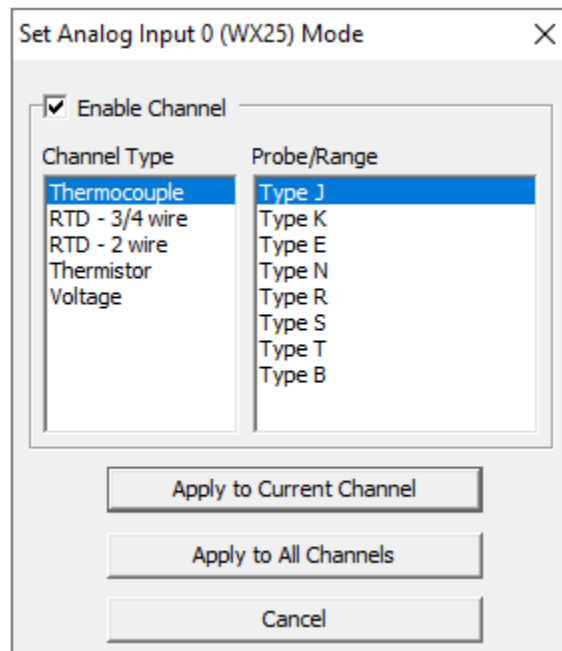

2. *Set Analog Input x*

Enable Channel – Check the box to enable this channel.

Channel Type – Select the type of device for this channel. This can be different for each channel.

Probe/Range – Select the style of device for this channel.

Apply to Current Channel – Apply these settings to just this one channel.

Apply to All Channels – Apply these settings to every channel on the card.

Cancel – Make no changes and leave this dialog.

BX-4UT4TD2 Universal Temperature Input/ DC Sourcing Output, continued

Setup BX-3UT4TD2 Module

Module Configuration Name: Info:

Analog Inputs 0-3 | Global Settings

Analog Input 0

Thermocouple Type J

Filter Time:
Time is in seconds. Enter 0 to disable.

WX25
Range: -346 - 2192
Units/Ct: 1DegF
Out of Range: X56
Burn Out: X57

RX25
Range: -346.00 - 2192.00

3. *WXx*

Range – The temperature in whole degrees for the selected channel on the module.

Units/Ct – The amount of temperature change that will equal 1 raw count.

Out of Range – The input register that, when On, will indicate that the input is outside of the range selected.

Burn Out – If burn out is enabled, this register will be On when the loop is broken.

4. *RXx*

Range – The floating point value of the channel temperature.

Setup BX-3UT4TD2 Module

Module Configuration Name: Info:

Analog Inputs 0-3 | Global Settings

Global Settings

Temperature Scale

Fahrenheit (Deg F)
 Celsius (Deg C)

A/C Rejection

50/60Hz @75dB
 60Hz @120dB
 50Hz @120dB

5. *Temperature Scale*

Select Fahrenheit or Celsius.

6. *A/C Rejection*

The rejection range for the common mode rejection. This is typically set to the AC line frequency at the installation.

BX-4UT4TR Universal Temperature Input/ Relay Output

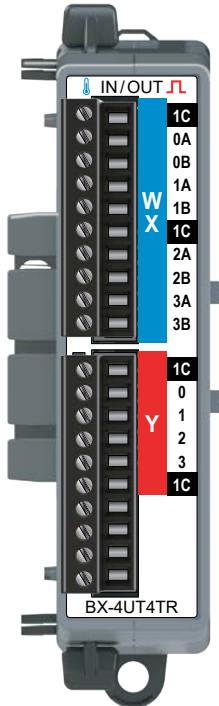

BX-4UT4TR

Universal Temperature Input/
Relay Output Expansion Module
4-pt Universal Temperature Input
4-pt Relay Form A (SPST) Output

BX-RTB10 Terminal Blocks Included.
The BX-RTB10-1 or BX-RTB10-2 can also be used and can be purchased separately.



NOTE: This device does not support
ZIPLink Wiring Systems.

IMPORTANT!



Hot-Swapping Information

Note: This device cannot be Hot Swapped.

Universal Temperature Input Specifications

	BX-4UT4TR
Input Channels	4 Differential
Commons	1
Input Impedance	>5M Ω
Resolution	24-bit, 0.1 $^{\circ}$ (C or F) See Data Range Specifications table
All Channel Update Rate	1s max (4 thermocouples enabled) 700ms max (4RTD/NTX/mV enabled)
Sample Duration Time	175ms
Open Circuit Detection Time	Within 5s
Maximum Ratings	-0.3 V to +5.3 V, <15mA
Common Mode Range	-0.3 V to +5.3 V
Common Mode Rejection	100dB@DC, 130dB@60Hz
Conversion Method	Sigma-Delta, 24-bit

Thermocouple Parameters

Thermocouple Input Ranges	Type J: -210 $^{\circ}$ to 1200 $^{\circ}$ C (-346 $^{\circ}$ to 2192 $^{\circ}$ F) Type K: -265 $^{\circ}$ to 1372 $^{\circ}$ C (-445 $^{\circ}$ to 2502 $^{\circ}$ F) Type E: -265 $^{\circ}$ to 1000 $^{\circ}$ C (-445 $^{\circ}$ to 1832 $^{\circ}$ F) Type N: -265 $^{\circ}$ to 1300 $^{\circ}$ C (-445 $^{\circ}$ to 2372 $^{\circ}$ F) Type R: -50 $^{\circ}$ to 1768 $^{\circ}$ C (-58 $^{\circ}$ to 3214 $^{\circ}$ F) Type S: -50 $^{\circ}$ to 1768 $^{\circ}$ C (-58 $^{\circ}$ to 3214 $^{\circ}$ F) Type B: 40 $^{\circ}$ to 1820 $^{\circ}$ C (104 $^{\circ}$ to 3308 $^{\circ}$ F) Type T: -265 $^{\circ}$ to 400 $^{\circ}$ C (-445 $^{\circ}$ to 752 $^{\circ}$ F)
Linear Voltage Input Ranges	-31.25 to 31.25 mVDC -31.25 to 125mVDC -31.25 to 62.5 mVDC 0 to 1.0 VDC
Cold Junction Compensation	Automatic
Thermocouple Linearization	Automatic
Maximum Inaccuracy–Thermocouple	$\pm(0.2^{\circ}\text{C} + 3\%$ of $^{\circ}\text{C}$ reading)
Maximum Inaccuracy–Voltage	$\pm 250\mu\text{V}$

RTD/Thermistor Parameters

Input Ranges (RTD Types)	10, 50, 100, 200, 500, 1000 Ω Pt Platinum RTD 0.00385 European Curve: -200 $^{\circ}$ to 850 $^{\circ}$ C (-328 $^{\circ}$ to 1562 $^{\circ}$ F) 120 Ω Ni N120 Nickel RTD 0.00672 Curve: -80 $^{\circ}$ to 260 $^{\circ}$ C (-112 $^{\circ}$ to 500 $^{\circ}$ F)
Thermistor Input Ranges	2.252 k Ω @ 25 $^{\circ}$ C: -40 $^{\circ}$ to 150 $^{\circ}$ C (-40 $^{\circ}$ to 302 $^{\circ}$ F) 3 k Ω @ 25 $^{\circ}$ C: -40 $^{\circ}$ to 150 $^{\circ}$ C (-40 $^{\circ}$ to 302 $^{\circ}$ F) 5 k Ω @ 25 $^{\circ}$ C: -40 $^{\circ}$ to 150 $^{\circ}$ C (-40 $^{\circ}$ to 302 $^{\circ}$ F) 10k-AN Type 3 @ 25 $^{\circ}$ C: -40 $^{\circ}$ to 150 $^{\circ}$ C (-40 $^{\circ}$ to 302 $^{\circ}$ F) 30 k Ω @ 25 $^{\circ}$ C: -40 $^{\circ}$ to 150 $^{\circ}$ C (-40 $^{\circ}$ to 302 $^{\circ}$ F)
Thermistor Excitation Current	NTC 2.252k, NTC 3k: 10 μA NTC 5k, NTC 10k: 5 μA NTC 30k: 1 μA
RTD Excitation Current	RTD 10, 100, 120, 200: 1mA RTD 500: 500 μA RTD 1000: 250 μA
RTD/Thermistor Linearization	Automatic
Maximum Inaccuracy	$\pm 0.2^{\circ}\text{C}$

BX-4UT4TR Universal Temperature Input/ Relay Output, continued

Voltage Relay Output Specifications	
	BX-4UT4TR
Outputs per Module	4
Commons	1
Maximum Current per Common	8A
Nominal Voltage	5–48VDC, 24–240VAC
Operating Voltage Range	5–60VDC, 18–264VAC
Peak Voltage	60VDC, 264VAC
Minimum Output Current	0.1 mA @ 24VDC
Maximum Output Current	2A
Maximum Inrush Current	5A for 50ms
Maximum Leakage Current	1 μ A
ON Voltage Drop	0.2 V maximum
Fuses, Overcurrent Protection	N/A
OFF-ON Response	<10ms
ON-OFF Response	<10ms
Relay Cycle Life Mechanical Endurance Electrical Endurance	5 Million Operations 120,000 Operations
Status Indicators	Logic Side, Green

Module General Specifications	
Weight	98g (3.5 oz)
Heat Dissipation	3.6 W
Backplane Power Consumption	2.5 W
Agency Approvals	UL 61010-2 File E185989, Canada and USA
Software Version Required	Do-more! Designer 2.7 or later

BX-4UT4TR Universal Temperature Input/ Relay Output, continued

Data Range Specifications			
Thermocouple Selection	Temperature Range	Resolution	
		WXn	RXn
Type J	-210 to 1200 °C -346 to 2192 °F	Degrees x10 (One Implied Decimal) ¹	24-Bit Floating ¹
Type K	-265 to 1372 °C -445 to 2502 °F		
Type E	-265 to 1000 °C -445 to 1832 °F		
Type R	-50 to 1768 °C -58 to 3214 °F		
Type S	-50 to 1768 °C -58 to 3214 °F		
Type B	40 to 1820 °C 104 to 3308 °F ³		
Type T	-265 to 400 °C -445 to 752 °F		
Voltage Selection	Voltage Range	WXn ²	RXn
-31.25 to 31.25 mVDC	Bipolar 31.25 mVDC	0.95 µV per count (-32768 to 32767)	User Scaled
-31.25 to 62.5 mVDC	Bipolar 62.5 mVDC	1.9 µV per count (-16384 to 32767)	
-31.25 to 125 mVDC	Bipolar 125 mVDC	3.8 µV per count (-8192 to 32767)	
0 to 1.0 VDC	Unipolar 1.0 VDC	30.5 µV per count (0 to 32767)	
RTD Selection	Temperature Range	WXn	RXn
10, 50, 100, 200, 500, 1000Ω Pt Platinum RTD 0.00385 European Curve	-200 to 850 °C -328 to 1562 °F	Degrees x10 (One Implied Decimal) ¹	24-Bit Floating ¹
120Ω Ni N120 Nickel RTD 0.00672 Curve	-80 to 260 °C -112 to 500 °F		
Thermistor Selection	Temperature Range	WXn	RXn
Thermistor 2.252 kΩ @25°C	-40 to 150 °C -40 to 302 °F	Degrees x10 (One Implied Decimal) ¹	24-Bit Floating ¹
Thermistor 3kΩ @25°C			
Thermistor 5kΩ @25°C			
Thermistor 10k-AN Type 3 @25°C			
Thermistor 30kΩ @25°C			

1. Temperatures reported in rounded integer to WXn and as scaled floating point 24bits resolution to RXn.

2. Raw Counts = -32768 to 32767.

3. Max value displayed in WXn is 32767. RXn will display the full range of 3308.0.

The module reserves the first 8 bits of unused contiguous space in the X register, aligned to an 8-bit word boundary, for status reporting. Error flags for this module are laid out within its status register space as described in the table below.

Error Flag Specifications								
	MSB							LSB
1st Byte of unused X Registers								
Module Status	Channel 4 Burnout	Channel 4 Out of Range	Channel 3 Burnout	Channel 3 Out of Range	Channel 2 Burnout	Channel 2 Out of Range	Channel 1 Burnout	Channel 1 Out of Range

BX-4UT4TR Universal Temperature Input/ Relay Output, continued

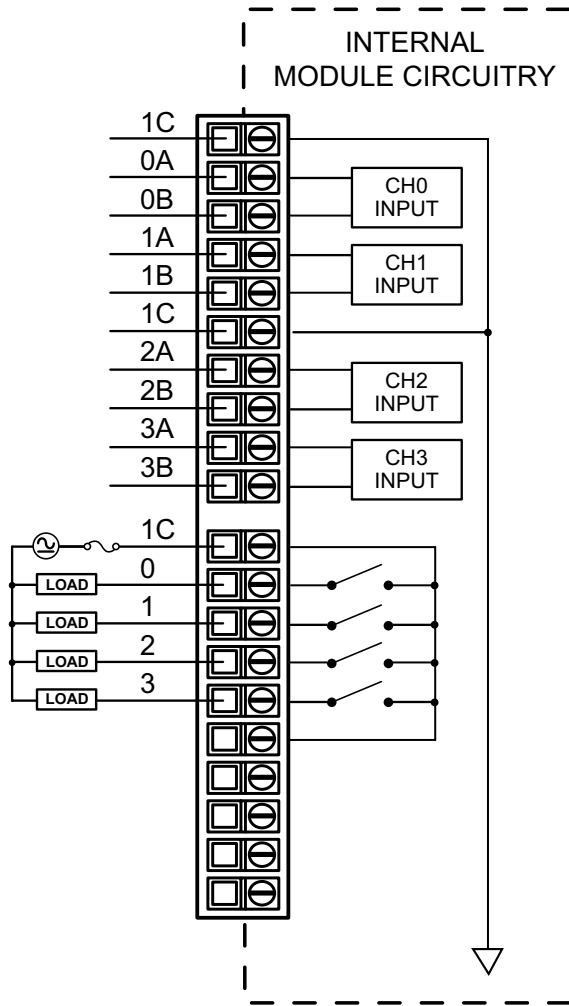

Relay Output

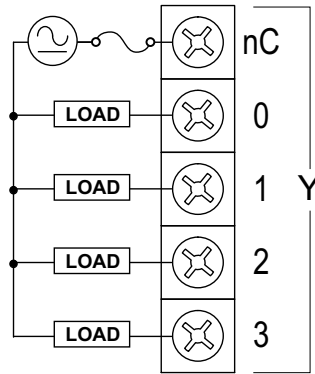

Resistive and Thermistor Sensors

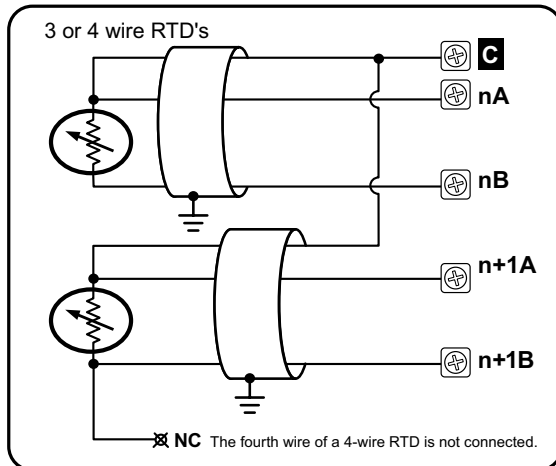
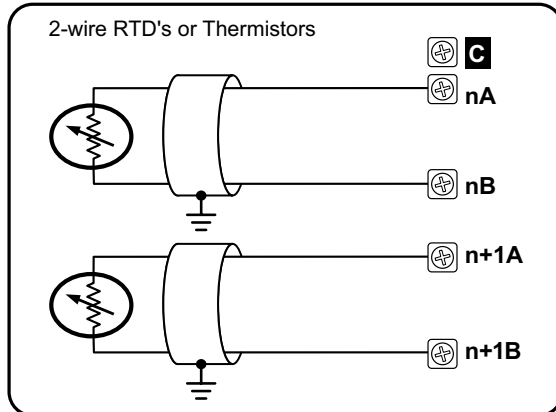

BX-4UT4TR Universal Temperature Input/ Relay Output, continued

Mixed Resistive and Thermocouple Sensors

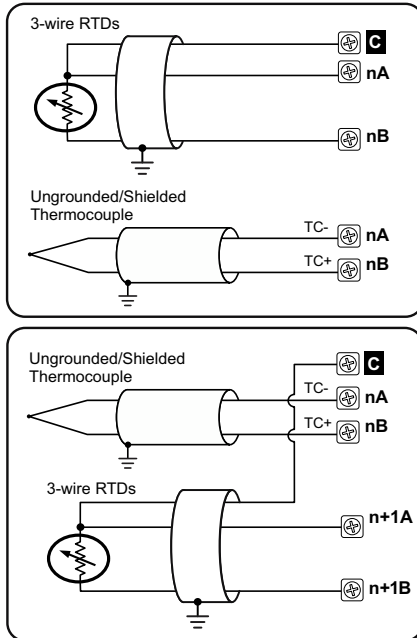

Notes for maximum accuracy:

1. All wires to an RTD must be equal length and type. Refer to RTD manufacturer's recommendations.
2. Do not use cable shield as sensing wire.
3. When applicable, connect shield to RTD common only, otherwise connect to module common only. Do not connect shield to both ends.
4. Jumper unused inputs.



Thermocouple and Voltage Sensors

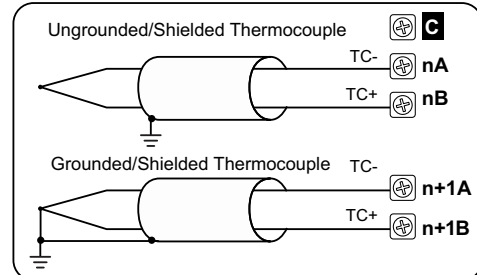

NOTE: Thermocouple extension wire and proper thermocouple terminal blocks must be used to extend thermocouples. AutomationDirect thermocouple wire is recommended.

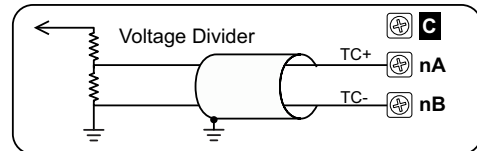
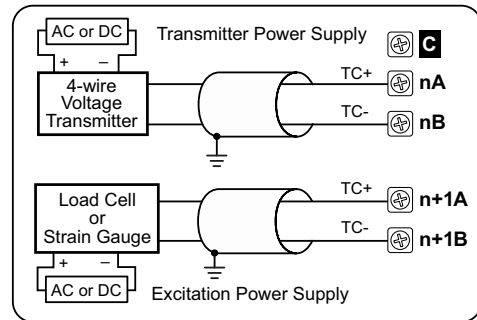

NOTE: Shield should be connected only at one end, to ground at the source device. For maximum accuracy: Jumper unused inputs.



NOTE: With grounded thermocouples, take precautions to prevent having a voltage potential between thermocouple tips. A voltage of 1.25 V or greater between tips will skew measurements.

BX-4UT4TR Universal Temperature Input/ Relay Output, continued

Software Setup

After the module is installed, open the Do-more! Designer programming software, connect to the BRX MPU and open the **Configure Module** dialog as described at the beginning of this chapter.

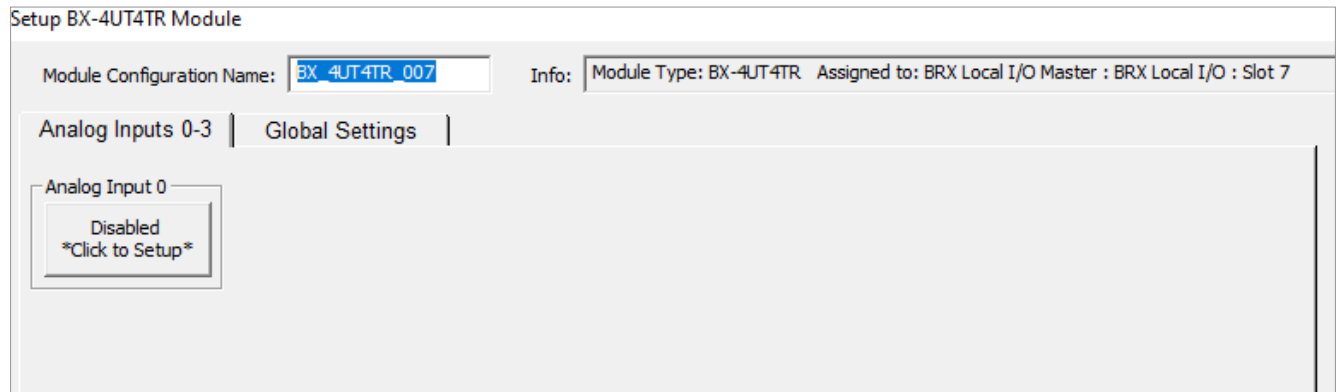

1. *Analog Input x*

Button – Click the button to set up the channel.

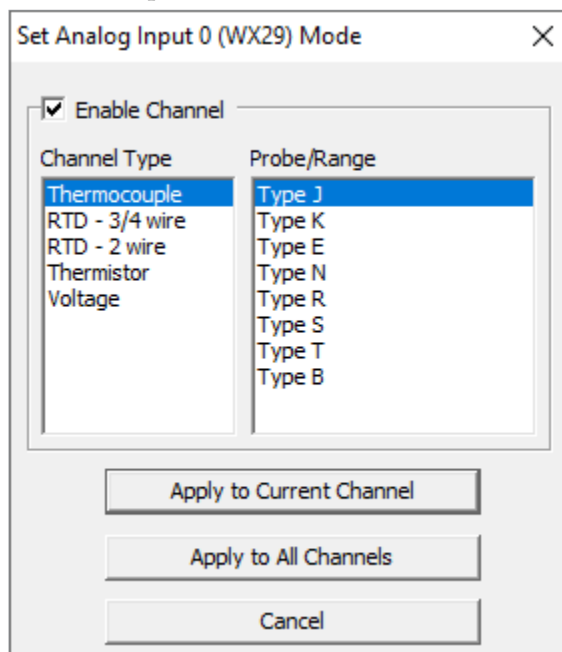

2. *Set Analog Input x*

Enable Channel – Check the box to enable this channel.

Channel Type – Select the type of device for this channel. This can be different for each channel.

Probe/Range – Select the style of device for this channel.

Apply to Current Channel – Apply these settings to just this one channel.

Apply to All Channels – Apply these settings to every channel on the card.

Cancel – Make no changes and leave this dialog.

BX-4UT4TR Universal Temperature Input/ Relay Output, continued

Setup BX-4UT4TR Module

Module Configuration Name: Info:

Analog Inputs 0-3 | Global Settings

Analog Input 0

Filter Time:

Time is in seconds. Enter 0 to disable.

WX29

Range: -346 - 2192

Units/Ct: 1DegF

Out of Range: X64

Burn Out: X65

RX29

Range: -346.00 - 2192.00

3. *WXx*

Range – The temperature in whole degrees for the selected channel on the module.

Units/Ct – The amount of temperature change that will equal 1 raw count.

Out of Range – The input register that, when On, will indicate that the input is outside of the range selected.

Burn Out – If burn out is enabled, this register will be On when the loop is broken.

4. *RXx*

Range – The floating point value of the channel temperature.

Setup BX-4UT4TR Module

Module Configuration Name: Info:

Analog Inputs 0-3 | Global Settings

Global Settings

Temperature Scale

Fahrenheit (Deg F)

Celsius (Deg C)

A/C Rejection

50/60Hz @75dB

60Hz @120dB

50Hz @120dB

5. *Temperature Scale*

Select Fahrenheit or Celsius.

6. *A/C Rejection*

The rejection range for the common mode rejection. This is typically set to the AC line frequency at the installation.