

BX 36/36E WIRING

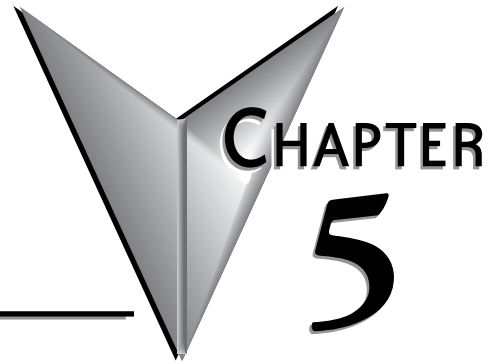

In This Chapter...

BX 36/36E Micro PLC Units (MPUs) Overview	5-2
BX 36 MPUs General Specifications	5-3
BX 36E MPUs General Specifications	5-4
BX 36/36E MPU Wiring Termination Selection	5-5
BX 36 Micro PLC Units (MPUs)	5-9
BX-DM1-36ED1 Wiring	5-9
BX-DM1-36ED1-D Wiring	5-15
BX-DM1-36ED2 Wiring	5-21
BX-DM1-36ED2-D Wiring	5-27
BX-DM1-36ER Wiring	5-33
BX-DM1-36ER-D Wiring	5-39
BX-DM1-36AR Wiring	5-45
BX 36E Micro PLC Units (MPUs)	5-50
BX-DM1E-36ED13 Wiring	5-50
BX-DM1E-36ED13-D Wiring	5-59
BX-DM1E-36ED23 Wiring	5-68
BX-DM1E-36ED23-D Wiring	5-77
BX-DM1E-36ER3 Wiring	5-86
BX-DM1E-36ER3-D Wiring	5-95
BX-DM1E-36AR3 Wiring	5-104

BX 36/36E Micro PLC Units (MPUs) Overview

The BX 36/36E Micro PLC Unit (MPU) includes fourteen different versions. All have the same appearance and basic features. All units have 20 discrete input points and 16 discrete output points built-in. Units with DC inputs have 10 selectable high-speed inputs and units with DC outputs have 8 selectable high-speed outputs. All MPUs can expand their capacity with the BRX Expansion Modules to allow for more flexibility while keeping control cost down. BX 36E units have an Ethernet port as well as an additional 4 analog inputs and 2 analog outputs built-in that are current/voltage selectable within the software.

The units ship without wiring terminals. This allows you to select the termination type that best fits your application. There are several wiring options available, including screw terminal connectors, spring clamp terminal connectors and pre-wired *ZIPLink* cable solutions.

BX 36/36E MPUs are divided into two distinct groups, BX 36 and BX 36E. The BX 36 MPUs have no built-in analog I/O or Ethernet port. The BX 36E MPUs have all the features of the BX 36, plus built-in analog I/O and an Ethernet port.

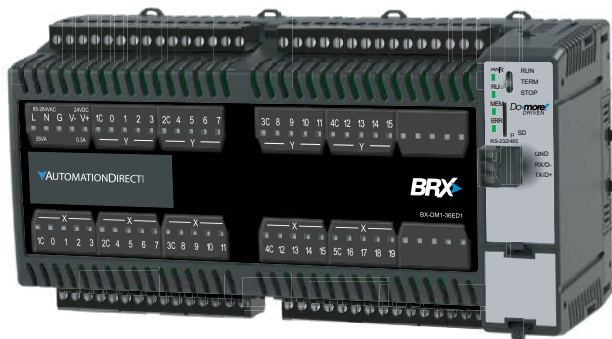

BX 36 Micro PLC Unit (MPU)
(No Built-in Analog or Ethernet Port)

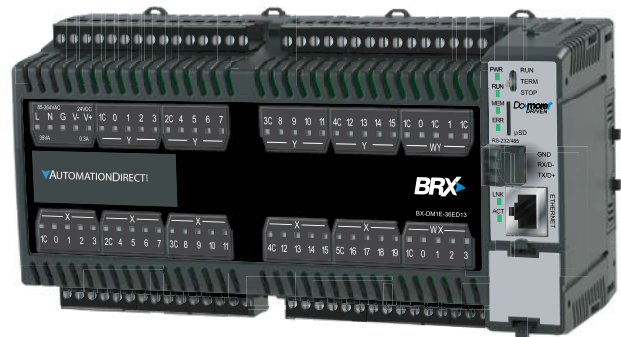

BX 36E Micro PLC Unit (MPU)
(Built-in Analog and Ethernet Port)

BX 36 MPUs General Specifications

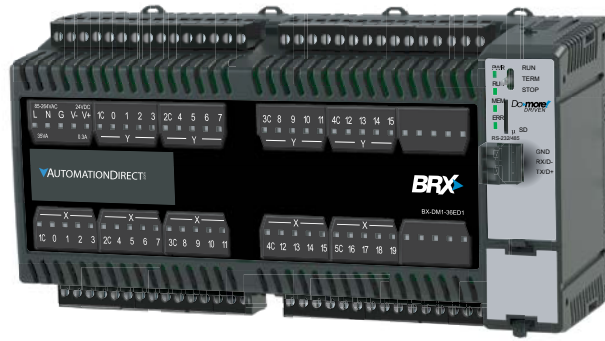

BX 36 Micro PLC Unit (MPU)
(No Built-in Analog or Ethernet port)

- 36 discrete I/O points: 20 input, 16 output
- No built-in analog I/O points
- Models with DC inputs:
 - have 10 high-speed inputs rated up to 250kHz
 - accept 12–24 nominal voltage, AC or DC
 - can be wired as sinking or sourcing
- Models with AC inputs can accept 120–240 nominal voltages
- Output types available are DC sinking, DC sourcing, and relay
- Models with DC outputs have 8 high-speed outputs rated up to 250kHz
- Support for up to 8 additional Expansion Modules as long as the power budget is not exceeded.

The following table shows the available BX 36 MPUs.

BX 36 MPUs				
Part Number	External Power	Discrete Input	Discrete Output	Expansion Modules
BX-DM1-36ED1	120–240 VAC	10 High-speed 10 Standard DC Sinking or Sourcing	8 High-speed 8 Standard DC Sinking	8, as long as the MPU power budget is not exceeded
BX-DM1-36ED1-D	12–24 VDC		8 High-speed 8 Standard DC Sourcing	
BX-DM1-36ED2	120–240 VAC		16 Form A Relay	
BX-DM1-36ED2-D	12–24 VDC			
BX-DM1-36ER	120–240 VAC	20 AC		
BX-DM1-36ER-D	12–24 VDC			
BX-DM1-36AR	120–240 VAC			

BX 36E MPUs General Specifications

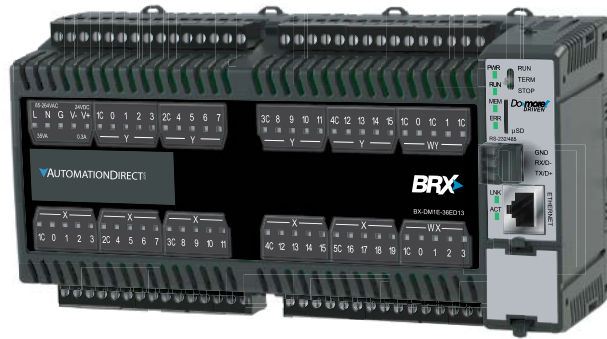

BX 36E Micro PLC Unit (MPU)
(Built-in Analog and Ethernet Port)

- 36 Discrete I/O points: 20 inputs, 16 outputs
- All units have 4 analog input and 2 analog output (current/voltage software selectable)
- All units have built-in Ethernet port, 10/100 Mbps
- Models with DC inputs:
 - have 10 high-speed inputs rated up to 250kHz
 - accept 12–24 nominal voltages, AC or DC
 - can be wired as sinking or sourcing
- Models with AC inputs can accept 120–240 nominal voltages
- Output types available are DC sinking, DC sourcing, and relay
- Models with DC outputs have 8 high-speed outputs rated up to 250kHz
- Support for 8 additional Expansion Modules

The following table shows the available BX 36E MPUs.

BX 36E MPUs						
Part Number	External Power	Discrete Inputs	Discrete Output	Analog *		Expansion Modules
				Input	Output	
BX-DM1E-36ED13	120–240 VAC	10 High-speed 10 Standard DC Sinking or Sourcing	8 High-Speed 8 Standard DC Sinking	4 Current or Voltage	2 Current or Voltage	8
BX-DM1E-36ED13-D	12–24 VDC					
BX-DM1E-36ED23	120–240 VAC		8 High-Speed 8 Standard DC Sourcing			
BX-DM1E-36ED23-D	12–24 VDC					
BX-DM1E-36ER3	120–240 VAC		16 Form A Relay			
BX-DM1E-36ER3-D	12–24 VDC					
BX-DM1E-36AR3	120–240 VAC	20 Standard AC				

* Analog can be current or voltage software selectable per channel.

BX 36/36E MPU Wiring Termination Selection

The BX 36/36E MPUs ship without terminal blocks. This allows you to select the termination type that best suits your application. There are several removable terminal block options available, including screw terminals, spring clamp terminals, as well as pre-wired *ZIPLink* module and cable solutions.

Terminal Block Connectors

The terminal block connectors are provided in kits and can be easily ordered as a single part number. Each kit contains the required number of terminal blocks: (12) 5-pin 5mm terminal blocks.

The BX 36/36E MPUs terminals are configured into groups consisting of 4 inputs and 4 outputs each with an isolated common, e.g., inputs X0–X3 are grouped with a common terminal. The groups are isolated such that a single 5-pin connector can be removed without affecting another group of I/O or the external power source.

The terminal block connector kit part numbers and connector specifications are listed in the table below.

Removable Terminal Block Connector Specifications		
Kit Part Number	BX-RTB36	BX-RTB36-1
Connector Type	Screw Type-90 degree	Spring Clamp Type-180 degree
Wire Exit	180 degree	180 degree
Pitch	5.0 mm	5.0 mm
Screw Size	M2.5	N/A
Recommended Screw Torque	< 3.98 lb·in (0.45 N·m)	N/A
Screwdriver Blade Width	3.5 mm	3.5 mm
Wire Gauge (Single Wire)	28–12 AWG	28–14 AWG
Wire Gauge (Dual Wire)	28–16 AWG	28–16 AWG (Dual wire ferrule required)
Wire Strip Length	0.3 in (7.5 mm)	0.37 in (9.5 mm)
Equiv. Dinkle P/N	5ESDV-05P-BK	5ESDSR-05P-BK

BX-RTB36 Screw Terminal Block Kit

This terminal block kit has 12, 90 degree screw terminal blocks with 180 degree wire pass through.



5-Pin

BX-RTB36-1 Spring Terminal Block Kit

This terminal block kit has 12, Spring Clamp wire terminal blocks with 180 degree wire pass through.



5-Pin

Replacement terminal blocks can be ordered online at: www.AutomationDirect.com. Single replacement terminal blocks are listed in table below.

Replacement Terminal Blocks		
	BX-RTB36	BX-RTB36-1
5-pin	BX-RTB05	BX-RTB05-1

ZIPLink Prewired Cable Solutions

ZIPLinks eliminate the normally tedious process of wiring between devices by utilizing prewired cables and DIN rail mount connector modules. ZIPLinks are as simple as plugging in a cable connector at either end or terminating wires at only one end. Pre-wired cables keep installation clean and efficient, using less space at a fraction of the cost of standard terminal blocks. ZIPLink pre-wired cables connect directly from the MPU to a ZIPLink remote terminal block module or with the pigtail cable option, that allows for a convenient solution to wire the BRX platform to third-party devices. For the BX 36/36E MPUs, four (4) cables and four (4) ZIPLink feedthrough modules are needed to connect all the wiring termination points.

There are two (2) feedthrough module options available, the ZL-RTB20 and the ZL-RTB20-1. The ZL-RTB20 is a standard feedthrough remote terminal module while the ZL-RTB20-1 is a feedthrough remote terminal block having a more compact footprint, requiring less space in the control cabinet.

The table below lists the ZIPLink system options for the BX 36/36E MPUs.

BX 36/36E ZIPLink Selector					
Part No.	Component Type	Module Part No.	Max Qty Needed	Cable Part No.*	Max Qty Needed
BX-DM1-36ED1	Feedthrough	ZL-RTB20 (Standard) -OR- ZL-RTB20-1 (Compact)	4	ZL-BX-CBL15 ZL-BX-CBL15-1 ZL-BX-CBL15-2	4
BX-DM1-36ED1-D					
BX-DM1-36ED2					
BX-DM1-36ED2-D					
BX-DM1-36ER					
BX-DM1-36ER-D					
BX-DM1-36AR					
BX-DM1E-36ED13					
BX-DM1E-36ED13-D					
BX-DM1E-36ED23					
BX-DM1E-36ED23-D					
BX-DM1E-36ER3					
BX-DM1E-36ER3-D					
BX-DM1E-36AR3					

* Select the cable length: Blank = 0.5 m, -1 = 1.0 m, -2 = 2.0 m.
Available pigtail cables: ZL-BX-CBL15-1P = 1.0 m, ZL-BX-CBL15-2P = 2.0 m.

ZIPLink Prewired Cables

Custom molded **ZIPLink** prewired cables allow for fast and easy connection of field wiring and remote I/O to the BRX platform. The prewired cables are available in 0.5 meter, 1 meter and 2 meter lengths. Pigtail cables are used to connect the BRX platform directly to third-party devices, lowering your wiring cost and time. The pigtail cables are available in 1 meter and 2 meter lengths.



ZL-BX-CBL20
ZIPLink Prewired Cable

ZL-BX-CBL20-1P
ZIPLink Pigtail Cable

ZIPLink Remote Feedthrough Modules

Feedthrough modules provide low-cost and compact field wiring screw termination solutions for quickly connecting with the BRX platform. There are two (2) modules available for use with the BRX platform. The ZL-RTB20 and the ZL-RTB20-1. The ZL-RTB20 is a standard 2-row, 20-pin, DIN rail mountable feedthrough module. The ZL-RTB20-1 is a compact 3-row, 24-pin, DIN rail mountable feedthrough module with a smaller footprint design.

The **ZIPLink** remote feedthrough module specifications are listed in the table below.

ZIPLink Module Specifications		
Part Number	ZL-RTB20 (Maximum of 4 Needed)	ZL-RTB20-1 (Maximum of 4 Needed)
Number of positions	20 screw terminals, 2 rows	24 screw terminals, 3 rows
Screwdriver Width	1/8 in (3.8 mm) maximum	
Screw Torque	4.4 lb·in (0.5 N·m)	



ZL-RTB20



ZL-RTB20-1

ZIPLink System Examples

BX 36 MPU with *ZIPLink* pre-wired cables and ZL-RTB20 feedthrough modules.



BX 36 MPU with *ZIPLink* pigtail cables installed.

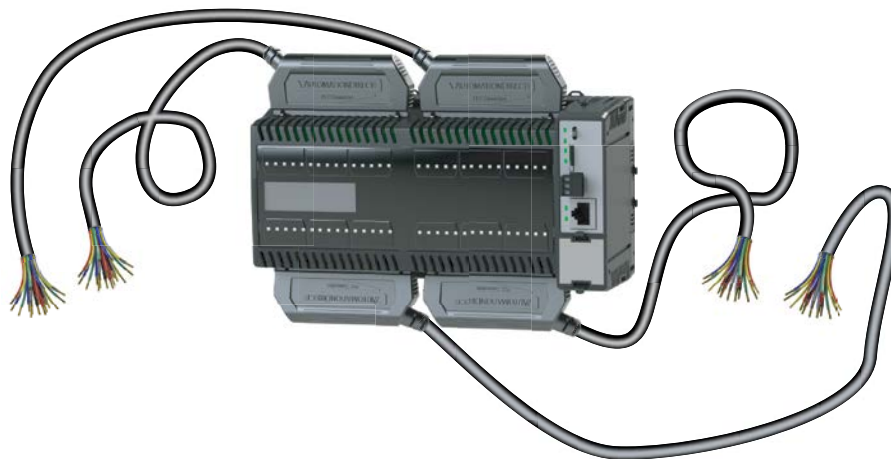

BX 36 Micro PLC Units (MPUs)

BX-DM1-36ED1 Wiring

This MPU is made up of 36 discrete I/O points. The connections are grouped as follows:

- 20 discrete inputs - sinking/sourcing; rated for 12–24 VAC/VDC. They are located along the bottom of the unit; configured in five (5) groups of 5 terminals, each comprised of 5 inputs and an isolated common.
- 16 discrete outputs - sinking; rated at 12–24 VDC. They are located along the top of the unit starting to the right of the 24VDC auxiliary output terminals. The outputs are configured in four (4) groups of 5 terminals, each comprised of 4 outputs and an isolated common.

This MPU requires an external 120–240 VAC power supply. The AC power supply connection and the 24VDC auxiliary output supply terminals are located on the top left side of the unit.



WARNING: No analog I/O is included on this unit. The 5 terminals to the right of the input and output rails are not used. These terminals are not internally connected. DO NOT CONNECT ANYTHING TO THESE TERMINALS!

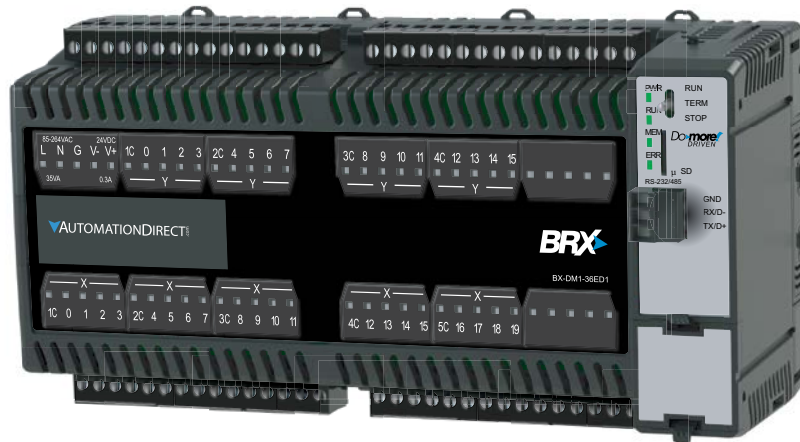

BX-DM1-36ED1



NOTE: Four (4) Expansion Modules can be connected to extend I/O capacity.

BX-DM1-36ED1 Wiring, Continued

Power Supply Specifications

Power Supply Specifications	
Nominal Voltage Range	120–240 VAC
Input Voltage Range (Tolerance)	85–264 VAC
Rated Operating Frequency	47–63 Hz
Maximum Input Power	40VA
Cold Start Inrush Current	1.5 A, 2ms
Maximum Inrush Current (Hot Start)	1.5 A, 2ms
Internal Input Fuse Protection	Micro fuse 250V, 2A Non-replaceable
Acceptable External Power Drop Time	10ms
Under Input Voltage Lock-out	80VAC
Input Transient Protection	Input choke and line filter
Heat Dissipation	21.7 W Max
Isolated User 24VDC Output	24VDC @ 0.3 A max, <1V P-P Ripple, Integrated self-resetting short circuit protection
Voltage Withstand (dielectric)	1500VAC Power Inputs to Ground applied for 1 minute 1500VAC Ground to 24VDC Output applied for 1 minute
Insulation Resistance	>10MΩ @ 500VDC
Software Version Required	Do-more! Designer version 2.0 or later

Power Supply Connections

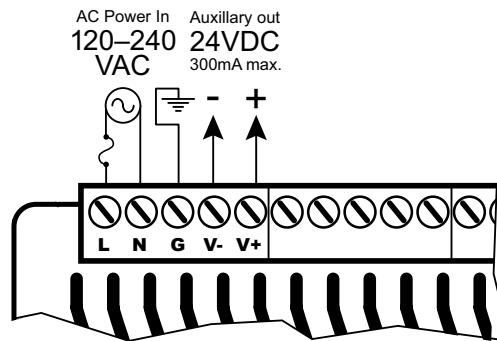

WARNING: Do not exceed the 24VDC auxiliary power supply load limit of 300mA.



WARNING: The BRX System **MUST** have a proper earth ground. Do not operate the BRX MPU without proper earth grounding.

BX-DM1-36ED1 Wiring, Continued

Discrete Input Specifications

Discrete Input Specifications			
Input Type	Sink/Source		
Total Inputs per Module	20		
Commons	5 (4 points/common) Isolated		
Nominal Voltage Range	12–24 VAC/VDC		
Input Voltage Range	9–30 VAC/VDC		
Maximum Voltage	30 VAC/VDC		
DC Frequency	0–250 kHz - High-speed		
Minimum Pulse Width	0.5 μ s - High-speed		
AC Frequency	47–63 Hz ²		
Input Impedance	3k Ω @ 24VDC		
Input Current (typical)	6mA @ 24 VAC/VDC		
Maximum Input Current	12mA @ 30 VAC/VDC		
ON Voltage Level	> 9.0 VAC/VDC		
OFF Voltage Level	< 2.0 VAC/VDC		
Maximum OFF Current	1.5 mA		
Status Indicators	Logic Side, Green		
Input Details			
Input Type	High-Speed DC		Standard ¹
Location	X0...X9		X10...X19
OFF to ON Response	DC	< 2 μ s	2ms
	AC	–	10ms ²
ON to OFF Response	DC	< 2 μ s	2ms
	AC	–	10ms ²
Maximum Switching Frequency	DC	250kHz	
	AC	~ 30Hz	

- 1. All inputs may be used as standard inputs. Only the first 10 inputs (X0...X9) are capable of high-speed DC operation.*
- 2. 60Hz to 240Hz filter should be set in the software when using an AC line signal.*

BX-DM1-36ED1 Wiring, Continued

Discrete Input Connection Options

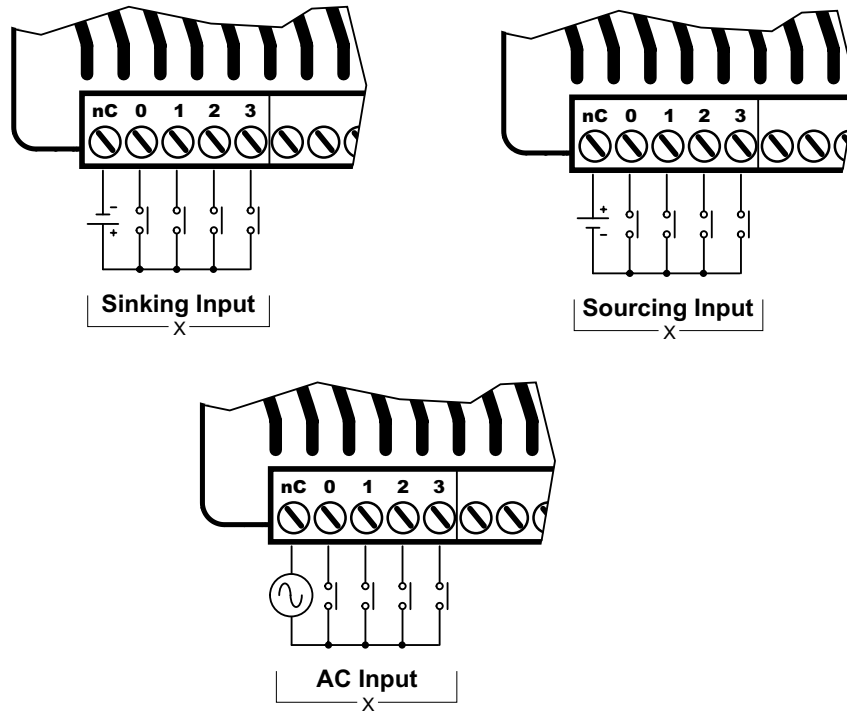

Discrete Input Internal Circuitry *

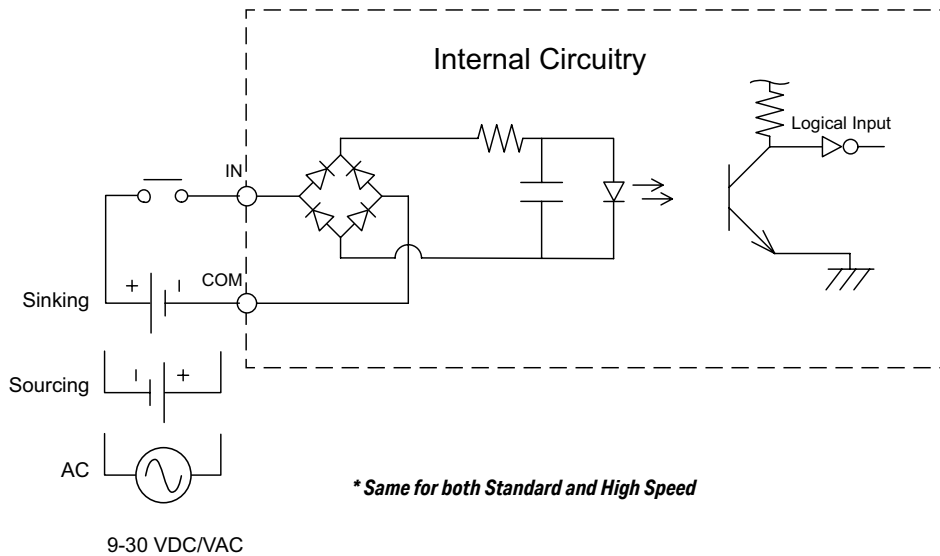

BX-DM1-36ED1 Wiring, Continued

Discrete Output Specifications

Discrete Output Specifications		
Output Type	Sinking	
Total Outputs per Module	16	
Commons	4 (4 points/common) Isolated	
Maximum Current per Common	2A	
Nominal Voltage Range	12–24 VDC	
Operating Voltage Range	5–36 VDC	
Maximum Voltage	36VDC	
Minimum Output Current	0.1 mA @ 24VDC	
Maximum Output Current	0.5 A per output No derating over temperature range	
Maximum Inrush Current	5A for 50ms	
Maximum Leakage Current	10 μ A	
ON Voltage Drop	0.05 VDC	
Status Indicators	Logic Side, Green	
Output Details		
Output Type	High-Speed	Standard ¹
Location	Y0...Y7	Y8...Y15
OFF to ON Response	< 2 μ s	< 5ms
ON to OFF Response	< 2 μ s	< 2ms
Maximum Switching Frequency	1m cable - 250kHz 10m cable - 100kHz	~100Hz
Overcurrent, Short Circuit Protection and Short to Ground	Current limit by Common Group, self-resetting	N/A
Overcurrent Trip Level ²	Between 4A and 8A	N/A
Fuse Type	User-supplied external fuse	

1. All outputs may be used as standard outputs. Only the first 8 outputs (Y0...Y7) are capable of high-speed DC operation.

2. When the high-speed outputs are in an overcurrent situation, the Common terminal Red LED is on. The output LEDs will remain operational even though the output circuitry is turned off and no power is flowing. This condition is not reported to the CPU.

BX-DM1-36ED1 Wiring, continued

Discrete Output Connection Options

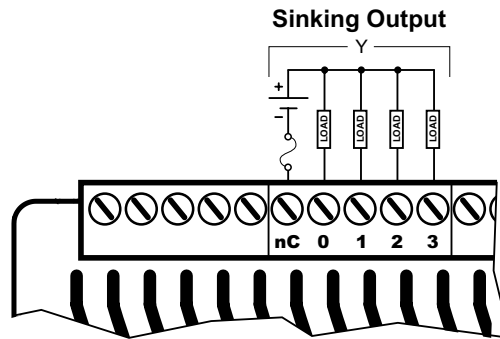

Discrete Standard Output Internal Circuitry

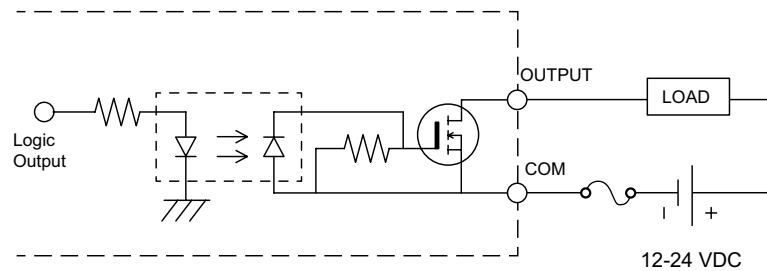

Discrete High-Speed Output Internal Circuitry

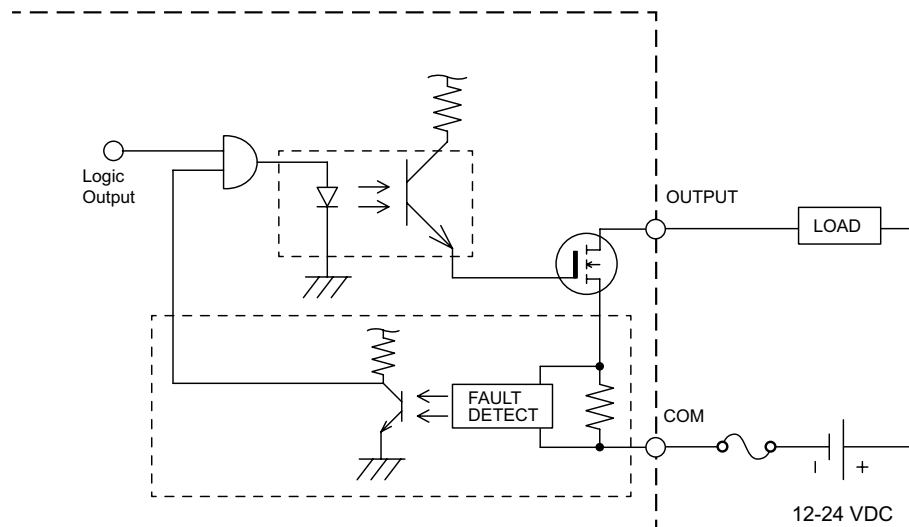

NOTE: When the high speed outputs are in an overcurrent situation, the Common terminal Red LED is on. The output LEDs will remain operational even though the output circuitry is turned off and no power is flowing. This condition is not reported to the CPU.

BX-DM1-36ED1-D Wiring

This MPU is made up of 36 discrete I/O points. The connections are grouped as follows:

- 20 discrete inputs - sinking/sourcing; rated for 12–24 VAC/VDC. They are located along the bottom of the unit; configured in five (5) groups of 5 terminals, each comprised of 4 inputs and an isolated common.
- 16 discrete outputs - sinking; rated at 12–24 VDC. They are located along the top of the unit starting to the right of the 24VDC external power supply terminals. The outputs are configured in four (4) groups of five (5) terminals, each comprised of four (4) outputs and an isolated common.

The MPU requires an external 12–24 VDC power supply. The DC power supply connection is located on the top left side of the unit. There is no 24VDC auxiliary output supply.



WARNING: No analog I/O is included on this unit. The 5 terminals to the right of the input and output rails are not used. These terminals are not internally connected. DO NOT CONNECT ANYTHING TO THESE TERMINALS!

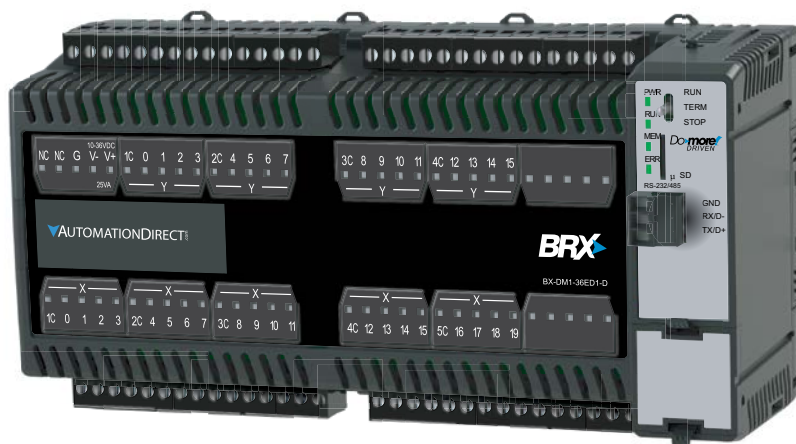

BX-DM1-36ED1-D



NOTE: Eight (8) Expansion Modules can be connected to extend I/O capacity, as long as the MPU power budget is not exceeded.

BX-DM1-36ED1-D Wiring, Continued

Power Supply Specifications

Power Supply Specifications	
Nominal Voltage Range*	12–24 VDC
Input Voltage Range (Tolerance)*	10–36 VDC
Maximum Input Voltage Ripple	< ±10%
Maximum Input Power	30W
Cold Start Inrush Current	5A, 2ms
Maximum Inrush Current (Hot Start)	5A, 2ms
Internal Input Protection	Reverse polarity protection and undervoltage lockout via transistor circuit
Acceptable External Power Drop Time	10ms
Under Input Voltage Lock-out	<9VDC
Heat Dissipation	19.5 W Max
Isolated User 24VDC Output	None
Voltage Withstand (dielectric)	1500VAC power Inputs to ground applied for 1 minute
Insulation Resistance	>10MΩ @ 500VDC
Software Version Required	Do-more! Designer version 2.0 or later

* Class 2 or LPS Power Supply required.

Power Supply Connections

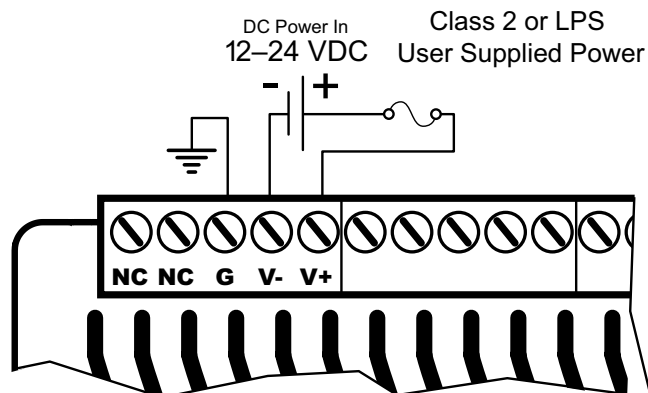

WARNING: No External AC power supply needed on this unit. The two terminals marked "NC" are not used. These terminals are not internally connected. **DO NOT CONNECT ANYTHING TO THESE TERMINALS!**



WARNING: The BRX System **MUST** have a proper earth ground. Do not operate the BRX MPU without proper earth grounding.

BX-DM1-36ED1-D Wiring, Continued

Discrete Input Specifications

Discrete Input Specifications			
Input Type	Sink/Source		
Total Inputs per Module	20		
Commons	5 (4 points/common) Isolated		
Nominal Voltage Range	12–24 VAC/VDC		
Input Voltage Range	9–30 VAC/VDC		
Maximum Voltage	30 VAC/VDC		
DC Frequency	0–250 kHz - High-speed		
Minimum Pulse Width	0.5 μ s - High-speed		
AC Frequency	47–63 Hz ²		
Input Impedance	3k Ω @ 24VDC		
Input Current (typical)	6mA @ 24 VAC/VDC		
Maximum Input Current	12mA @ 30 VAC/VDC		
ON Voltage Level	> 9.0 VAC/VDC		
OFF Voltage Level	< 2.0 VAC/VDC		
Maximum OFF Current	1.5 mA		
Status Indicators	Logic Side, Green		
Input Details			
Input Type	High-Speed DC	Standard ¹	
Location	X0...X9	X10...X19	
OFF to ON Response	DC	< 2 μ s	2ms
	AC	–	10ms ²
ON to OFF Response	DC	< 2 μ s	2ms
	AC	–	10ms ²
Maximum Switching Frequency	DC	250kHz	
	AC	~ 30Hz	

1. All inputs may be used as standard inputs. Only the first 10 inputs (X0...X9) are capable of high-speed DC operation.

2. 60Hz to 240Hz filter should be set in the software when using an AC line signal.

BX-DM1-36ED1-D Wiring, Continued

Discrete Input Connection Options

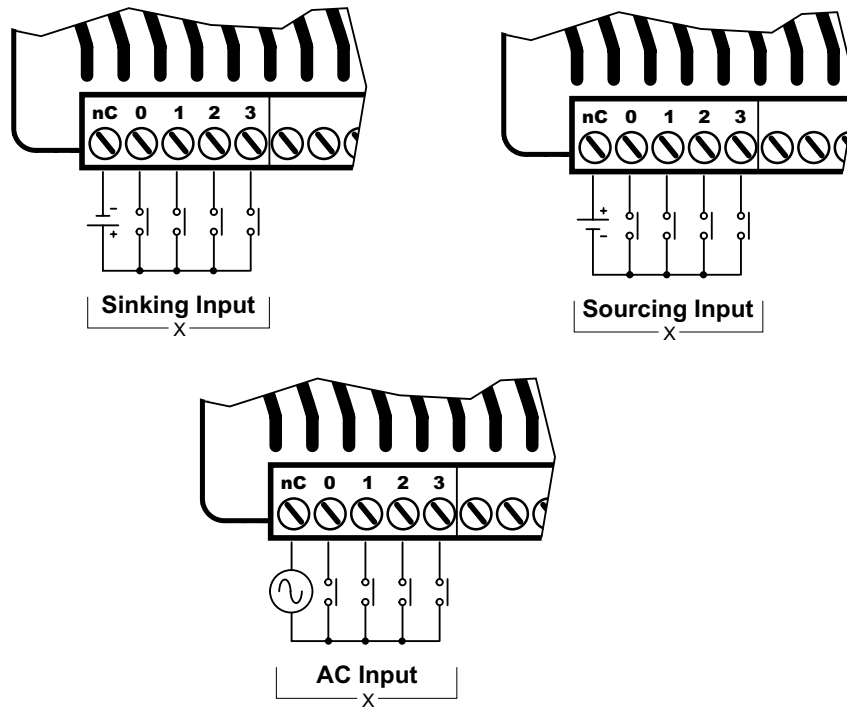

Discrete Input Internal Circuitry *

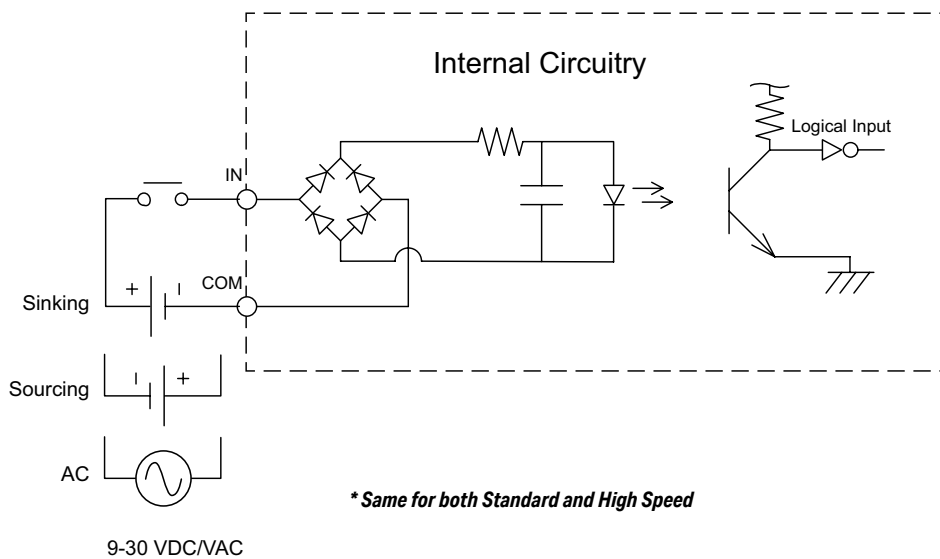

BX-DM1-36ED1-D Wiring, Continued

Discrete Output Specifications

Discrete Output Specifications		
Output Type	Sinking	
Total Outputs per Module	16	
Commons	4 (4 points/common) Isolated	
Maximum Current per Common	2A	
Nominal Voltage Range	12–24 VDC	
Operating Voltage Range	5–36 VDC	
Maximum Voltage	36VDC	
Minimum Output Current	0.1 mA @ 24VDC	
Maximum Output Current	0.5 A per output No derating over temperature range	
Maximum Inrush Current	5A for 50ms	
Maximum Leakage Current	10 μ A	
ON Voltage Drop	0.05 VDC	
Status Indicators	Logic Side, Green	
Output Details		
Output Type	High-Speed	Standard ¹
Location	Y0...Y7	Y8...Y15
OFF to ON Response	< 2 μ s	< 5ms
ON to OFF Response	< 2 μ s	< 2ms
Maximum Switching Frequency	1m cable - 250kHz 10m cable - 100kHz	~100Hz
Overcurrent, Short Circuit Protection and Short to Ground	Current limit by Common Group, self-resetting	N/A
Overcurrent Trip Level ²	Between 4A and 8A	N/A
Fuse Type	User-supplied external fuse	

- 1. All outputs may be used as standard outputs. Only the first 8 outputs (Y0...Y7) are capable of high-speed DC operation.*
- 2. When the high-speed outputs are in an overcurrent situation, the Common terminal Red LED is on. The output LEDs will remain operational even though the output circuitry is turned off and no power is flowing. This condition is not reported to the CPU.*

BX-DM1-36ED1-D Wiring, Continued

Discrete Output Connection Options

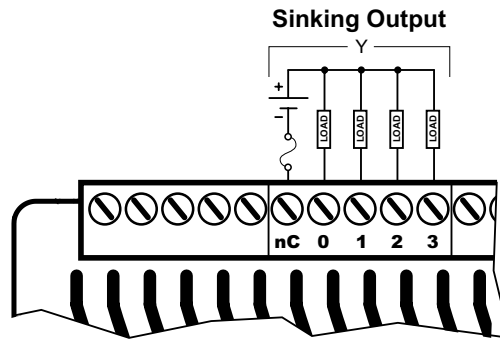

Discrete Standard Output Internal Circuitry

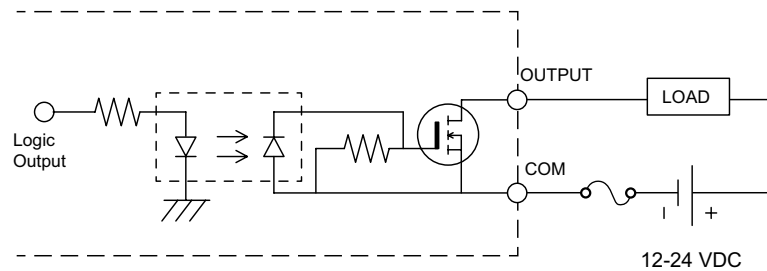

Discrete High-Speed Output Internal Circuitry

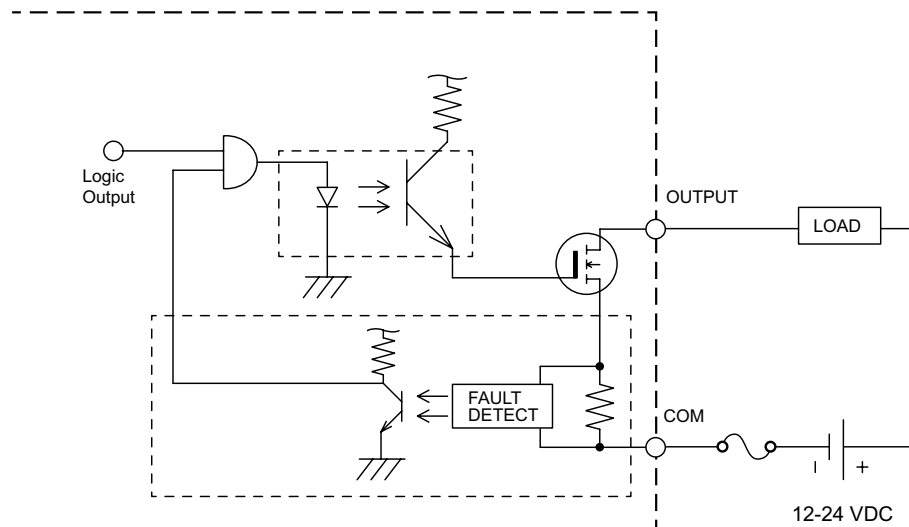

NOTE: When the high speed outputs are in an overcurrent situation, the Common terminal Red LED is on. The output LEDs will remain operational even though the output circuitry is turned off and no power is flowing. This condition is not reported to the CPU.

BX-DM1-36ED2 Wiring

This MPU is made up of 36 discrete I/O points. The connections are grouped as follows:

- 20 discrete inputs - sinking/sourcing; rated for 12–24 VAC/VDC. They are located along the bottom of the unit; configured in five (5) groups of 5 terminals, each comprised of 4 inputs and an isolated common.
- 16 discrete outputs - sourcing; rated at 12–24 VDC. They are located along the top of the unit starting to the right of the 24VDC auxiliary output terminals. The outputs are configured in four (4) groups of 5 terminals, each comprised of 4 outputs and an isolated common.

This MPU requires an external 120–240 VAC power supply. The AC power supply connection and the 24VDC auxiliary output supply terminals are located on the top left side of the unit.



WARNING: No analog I/O is included on this unit. The 5 terminals to the right of the input and output rails are not used. These terminals are not internally connected. DO NOT CONNECT ANYTHING TO THESE TERMINALS!

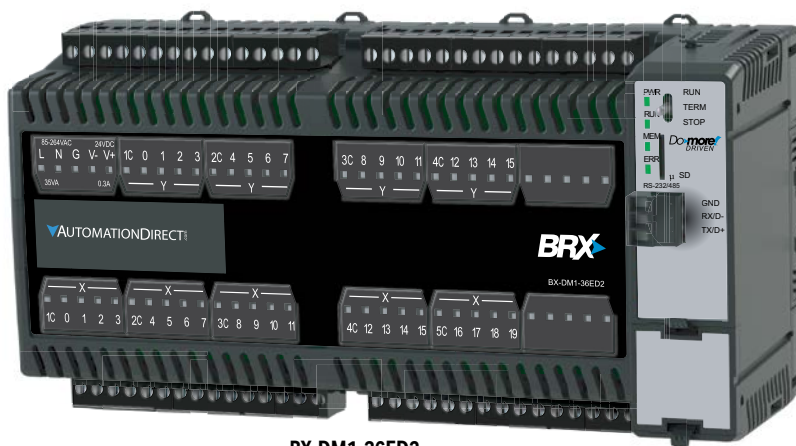

BX-DM1-36ED2



NOTE: Eight (8) Expansion Modules can be connected to extend I/O capacity, as long as the MPU power budget is not exceeded.

BX-DM1-36ED2 Wiring, Continued

Power Supply Specifications

Power Supply Specifications	
Nominal Voltage Range	120–240 VAC
Input Voltage Range (Tolerance)	85–264 VAC
Rated Operating Frequency	47–63 Hz
Maximum Input Power	40VA
Cold Start Inrush Current	1.5 A, 2ms
Maximum Inrush Current (Hot Start)	1.5 A, 2ms
Internal Input Fuse Protection	Micro fuse 250V, 2A Non-replaceable
Acceptable External Power Drop Time	10ms
Under Input Voltage Lock-out	80VAC
Input Transient Protection	Input choke and line filter
Heat Dissipation	21.7 W Max
Isolated User 24VDC Output	24VDC @ 0.3 A max, <1V P-P Ripple, Integrated self-resetting short circuit protection
Voltage Withstand (dielectric)	1500VAC Power Inputs to Ground applied for 1 minute 1500VAC Ground to 24VDC Output applied for 1 minute
Insulation Resistance	>10MΩ @ 500VDC
Software Version Required	Do-more! Designer version 2.0 or later

Power Supply Connections

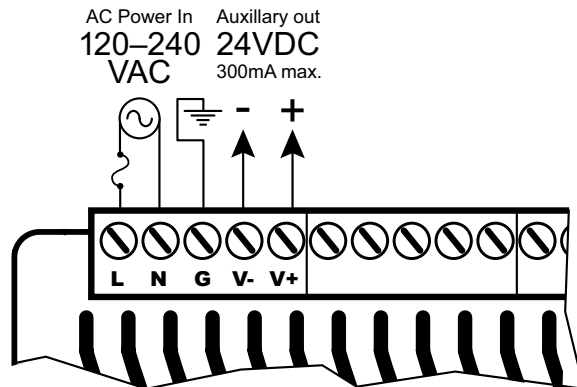

WARNING: Do not exceed the 24VDC auxiliary power supply load limit of 300mA.



WARNING: The BRX System **MUST** have a proper earth ground. Do not operate the BRX MPU without proper earth grounding.

BX-DM1-36ED2 Wiring, Continued

Discrete Input Specifications

Discrete Input Specifications			
Input Type	Sink/Source		
Total Inputs per Module	20		
Commons	5 (4 points/common) Isolated		
Nominal Voltage Range	12–24 VAC/VDC		
Input Voltage Range	9–30 VAC/VDC		
Maximum Voltage	30 VAC/VDC		
DC Frequency	0–250 kHz - High-speed		
Minimum Pulse Width	0.5 μ s - High-speed		
AC Frequency	47–63 Hz ²		
Input Impedance	3k Ω @ 24VDC		
Input Current (typical)	6mA @ 24 VAC/VDC		
Maximum Input Current	12mA @ 30 VAC/VDC		
ON Voltage Level	> 9.0 VAC/VDC		
OFF Voltage Level	< 2.0 VAC/VDC		
Maximum OFF Current	1.5 mA		
Status Indicators	Logic Side, Green		
Input Details			
Input Type	High-Speed DC		Standard ¹
Location	X0...X9		X10...X19
OFF to ON Response	DC	< 2 μ s	2ms
	AC	–	10ms ²
ON to OFF Response	DC	< 2 μ s	2ms
	AC	–	10ms ²
Maximum Switching Frequency	DC	250kHz	
	AC	~ 30Hz	

1. All inputs may be used as standard inputs. Only the first 10 inputs (X0...X9) are capable of high-speed DC operation.

2. 60Hz to 240Hz filter should be set in the software when using an AC line signal.

BX-DM1-36ED2 Wiring, Continued

Discrete Input Connection Options

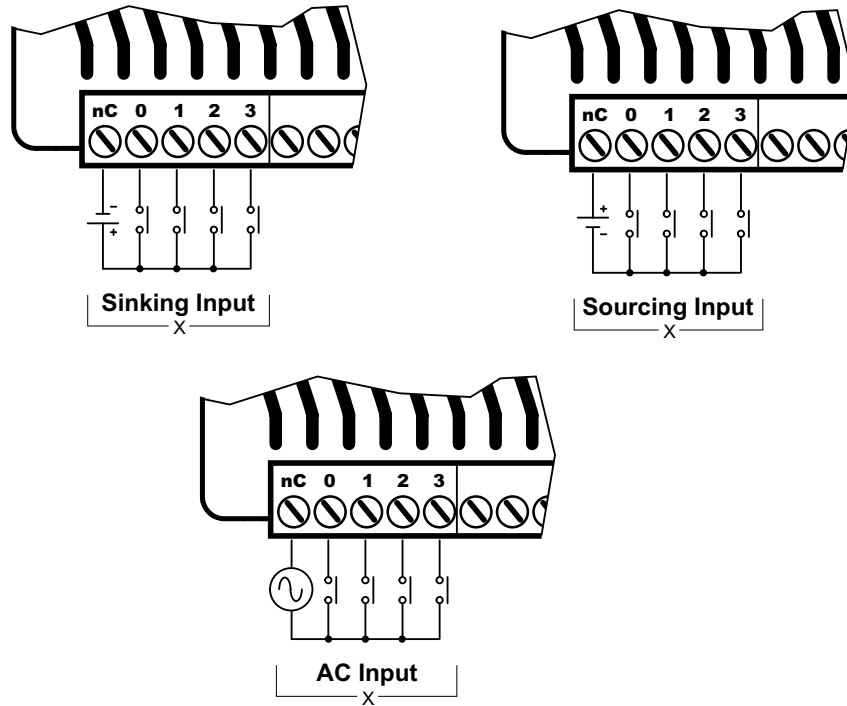

Discrete Input Internal Circuitry *

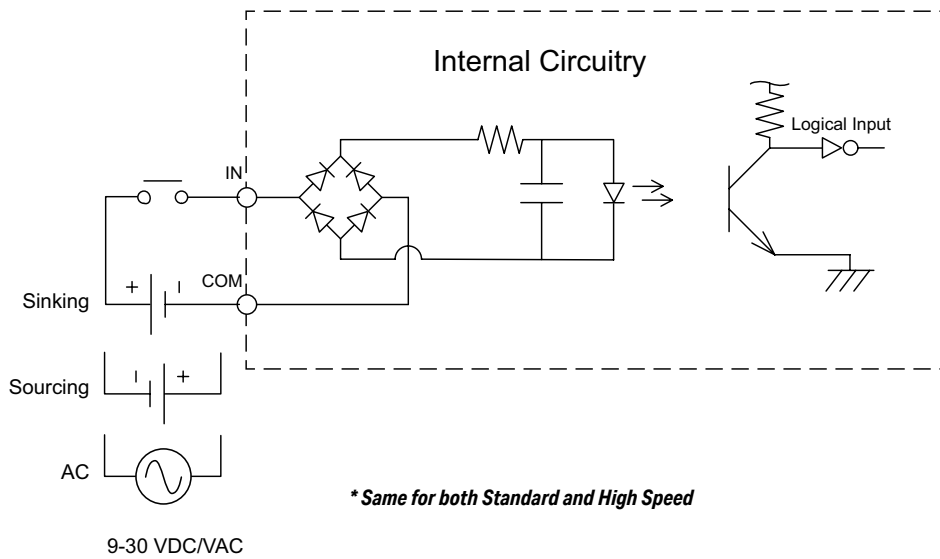

BX-DM1-36ED2 Wiring, Continued

Discrete Output Specifications

Discrete Output Specifications		
Output Type	Sourcing	
Total Outputs per Module	16	
Commons	4 (4 points/common) Isolated	
Maximum Current per Common	2A	
Nominal Voltage Range	12–24 VDC	
Operating Voltage Range	5–36 VDC	
Maximum Voltage	36VDC	
Minimum Output Current	0.1 mA @ 24VDC	
Maximum Output Current	0.5 A per output No derating over temperature range	
Maximum Inrush Current	5A for 50ms	
Maximum Leakage Current	10 μ A	
ON Voltage Drop	0.05 VDC	
Status Indicators	Logic Side, Green	
Output Details		
Output Type	High-Speed	Standard ¹
Location	Y0...Y7	Y8...Y15
OFF to ON Response	< 2 μ s	< 5ms
ON to OFF Response	< 2 μ s	< 2ms
Maximum Switching Frequency	1m cable - 250kHz 10m cable - 100kHz	~100Hz
Overcurrent, Short Circuit Protection and Short to Ground	Current limit by Common Group, self-resetting	N/A
Overcurrent Trip Level ²	Between 4A and 8A	N/A
Fuse Type	User-supplied external fuse	

1. All outputs may be used as standard outputs. Only the first 8 outputs (Y0...Y7) are capable of high-speed DC operation.

2. When the high-speed outputs are in an overcurrent situation, the Common terminal Red LED is on. The output LEDs will remain operational even though the output circuitry is turned off and no power is flowing. This condition is not reported to the CPU.

BX-DM1-36ED2 Wiring, Continued

Discrete Output Connection Options

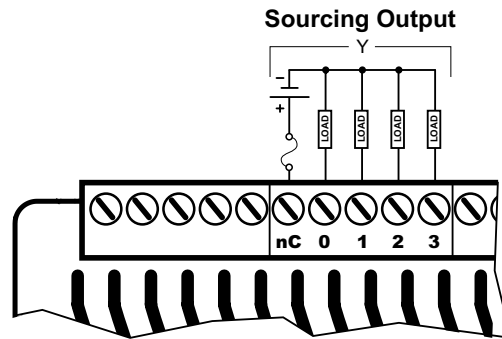

Discrete Standard Output Internal Circuitry

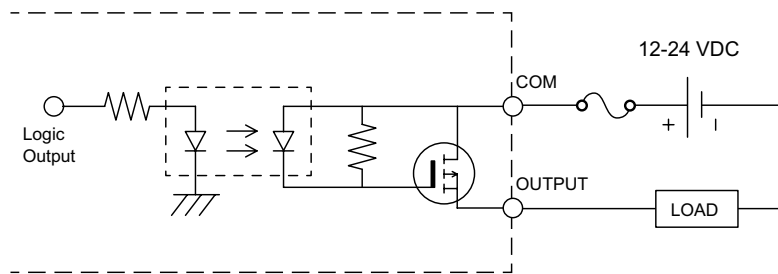

Discrete High-Speed Output Internal Circuitry

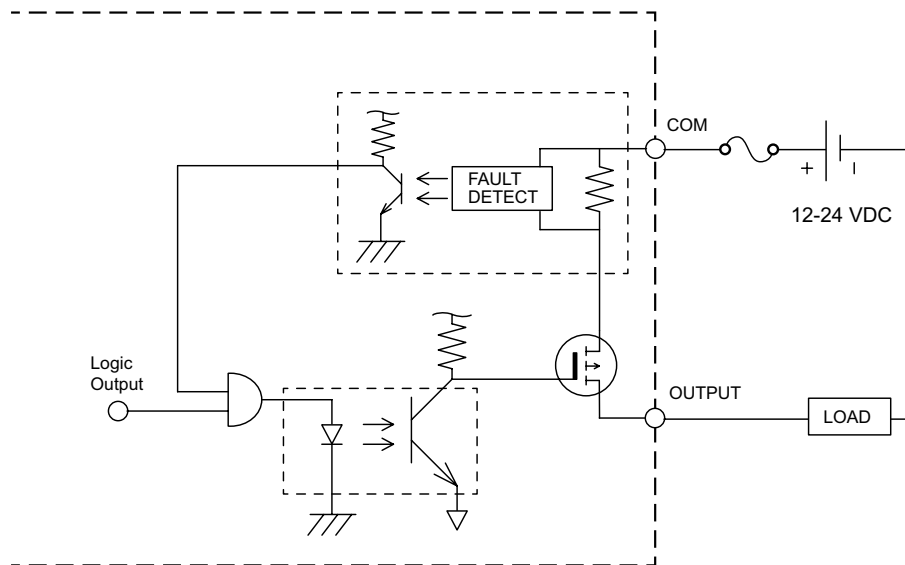

NOTE: When the high speed outputs are in an overcurrent situation, the Common terminal Red LED is on. The output LEDs will remain operational even though the output circuitry is turned off and no power is flowing. This condition is not reported to the CPU.

BX-DM1-36ED2-D Wiring

This MPU is made up of 36 discrete I/O points. The connections are grouped as follows:

- 20 discrete inputs - sinking/sourcing; rated for 12–24 VAC/VDC. They are located along the bottom of the unit; configured in five (5) groups of 5 terminals, each comprised of 4 inputs and an isolated common.
- 16 discrete outputs - sourcing; rated at 12–24 VDC. They are located along the top of the unit starting to the right of the 24VDC external power supply terminals. The outputs are configured in four (4) groups of 5 terminals, each comprised of 4 outputs and an isolated common.

This MPU requires an external 12–24 VDC power supply. The DC power supply connection is located on the top left side of the unit. There is no 24VDC auxiliary output supply.



WARNING: No analog I/O is included on this unit. The 5 terminals to the right of the input and output rails are not used. These terminals are not internally connected. DO NOT CONNECT ANYTHING TO THESE TERMINALS!

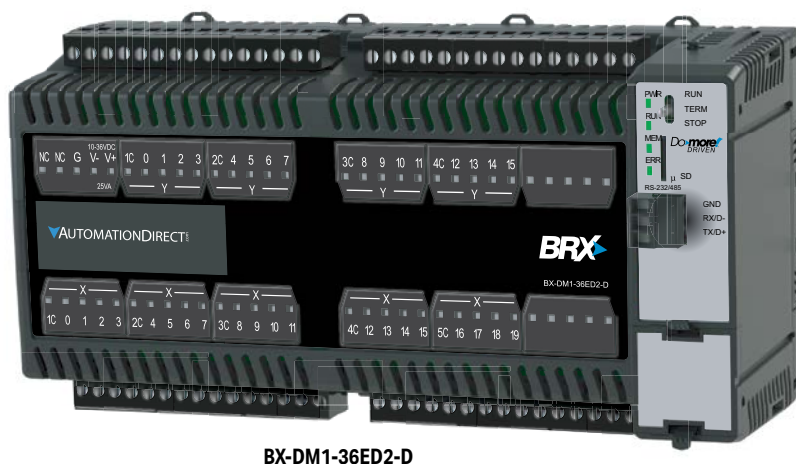

BX-DM1-36ED2-D



NOTE: Eight (8) Expansion Modules can be connected to extend I/O capacity, as long as the MPU power budget is not exceeded.

BX-DM1-36ED2-D, Continued

Power Supply Specifications

Power Supply Specifications	
Nominal Voltage Range*	12–24 VDC
Input Voltage Range (Tolerance)*	10–36 VDC
Maximum Input Voltage Ripple	< ±10%
Maximum Input Power	30W
Cold Start Inrush Current	5A, 2ms
Maximum Inrush Current (Hot Start)	5A, 2ms
Internal Input Protection	Reverse polarity protection and undervoltage lockout via transistor circuit
Acceptable External Power Drop Time	10ms
Under Input Voltage Lock-out	<9VDC
Heat Dissipation	19.5 W Max
Isolated User 24VDC Output	None
Voltage Withstand (dielectric)	1500VAC power Inputs to ground applied for 1 minute
Insulation Resistance	>10MΩ @ 500VDC
Software Version Required	Do-more! Designer version 2.0 or later

*Class 2 or LPS Power Supply required.

Power Supply Connections

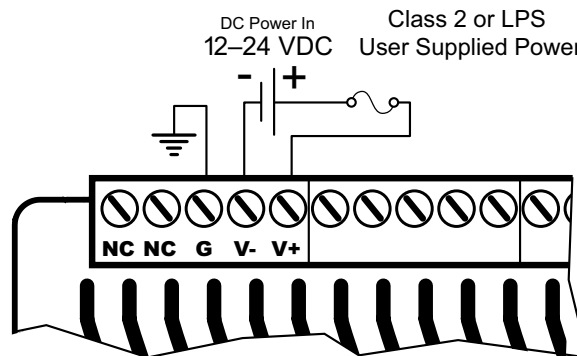

WARNING: No External AC power supply needed on this unit. The two terminals marked "NC" are not used. These terminals are not internally connected. **DO NOT CONNECT ANYTHING TO THESE TERMINALS!**



WARNING: The BRX System **MUST** have a proper earth ground. Do not operate the BRX MPU without proper earth grounding.

BX-DM1-36ED2-D Wiring, Continued

Discrete Input Specifications

Discrete Input Specifications			
Input Type	Sink/Source		
Total Inputs per Module	20		
Commons	5 (4 points/common) Isolated		
Nominal Voltage Range	12–24 VAC/VDC		
Input Voltage Range	9–30 VAC/VDC		
Maximum Voltage	30 VAC/VDC		
DC Frequency	0–250 kHz - High-speed		
Minimum Pulse Width	0.5 μ s - High-speed		
AC Frequency	47–63 Hz ²		
Input Impedance	3k Ω @ 24VDC		
Input Current (typical)	6mA @ 24 VAC/VDC		
Maximum Input Current	12mA @ 30 VAC/VDC		
ON Voltage Level	> 9.0 VAC/VDC		
OFF Voltage Level	< 2.0 VAC/VDC		
Maximum OFF Current	1.5 mA		
Status Indicators	Logic Side, Green		
Input Details			
Input Type		High-Speed DC	Standard ¹
Location		X0...X9	X10...X19
OFF to ON Response	DC	< 2 μ s	2ms
	AC	–	10ms ²
ON to OFF Response	DC	< 2 μ s	2ms
	AC	–	10ms ²
Maximum Switching Frequency	DC	250kHz	
	AC	~ 30Hz	

1. All inputs may be used as standard inputs. Only the first 10 inputs (X0...X9) are capable of high-speed DC operation.

2. 60Hz to 240Hz filter should be set in the software when using an AC line signal.

BX-DM1-36ED2-D Wiring, Continued

Discrete Input Connection Options

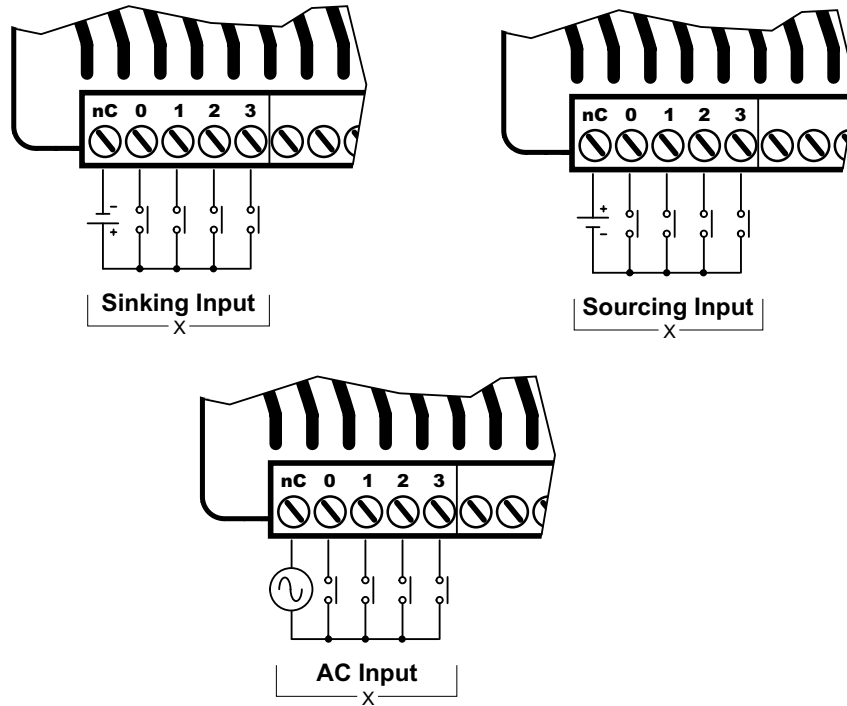

Discrete Input Internal Circuitry *

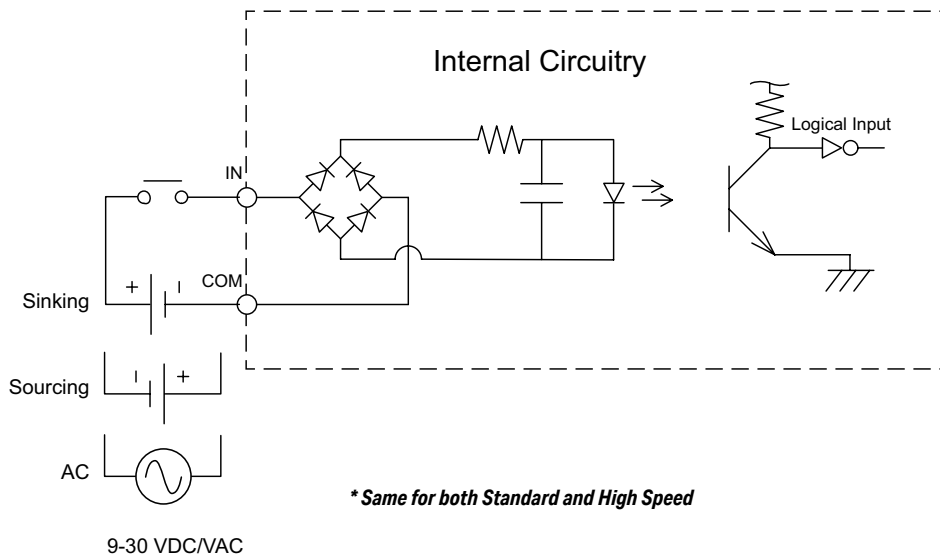

BX-DM1-36ED2-D Wiring, Continued

Discrete Output Specifications

Discrete Output Specifications		
Output Type	Sourcing	
Total Outputs per Module	16	
Commons	4 (4 points/common) Isolated	
Maximum Current per Common	2A	
Nominal Voltage Range	12–24 VDC	
Operating Voltage Range	5–36 VDC	
Maximum Voltage	36VDC	
Minimum Output Current	0.1 mA @ 24VDC	
Maximum Output Current	0.5 A per output No derating over temperature range	
Maximum Inrush Current	5A for 50ms	
Maximum Leakage Current	10 μ A	
ON Voltage Drop	0.05 VDC	
Status Indicators	Logic Side, Green	
Output Details		
Output Type	High-Speed	Standard ¹
Location	Y0...Y7	Y8...Y15
OFF to ON Response	< 2 μ s	< 5ms
ON to OFF Response	< 2 μ s	< 2ms
Maximum Switching Frequency	1m cable - 250kHz 10m cable - 100kHz	~100Hz
Overcurrent, Short Circuit Protection and Short to Ground	Current limit by Common Group, self-resetting	N/A
Overcurrent Trip Level ²	Between 4A and 8A	N/A
Fuse Type	User-supplied external fuse	

- 1. All outputs may be used as standard outputs. Only the first 8 outputs (Y0...Y7) are capable of high-speed DC operation.*
- 2. When the high-speed outputs are in an overcurrent situation, the Common terminal Red LED is on. The output LEDs will remain operational even though the output circuitry is turned off and no power is flowing. This condition is not reported to the CPU.*

BX-DM1-36ED2-D Wiring, Continued

Discrete Output Connection Options

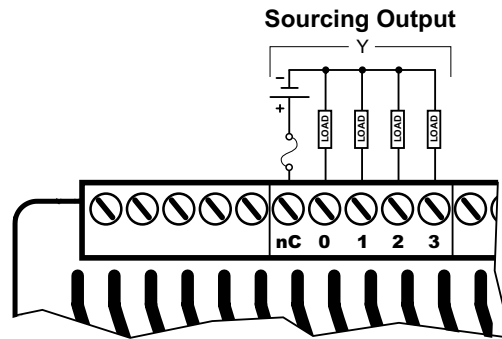

Discrete Standard Output Internal Circuitry

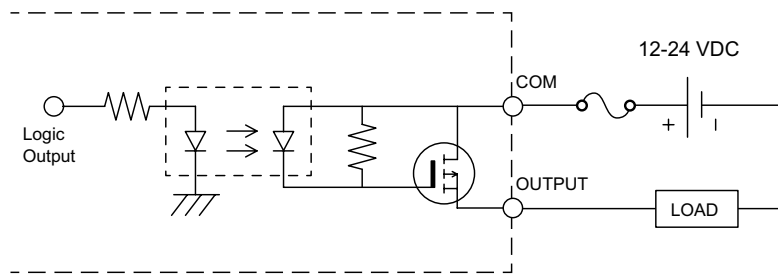

Discrete High-Speed Output Internal Circuitry

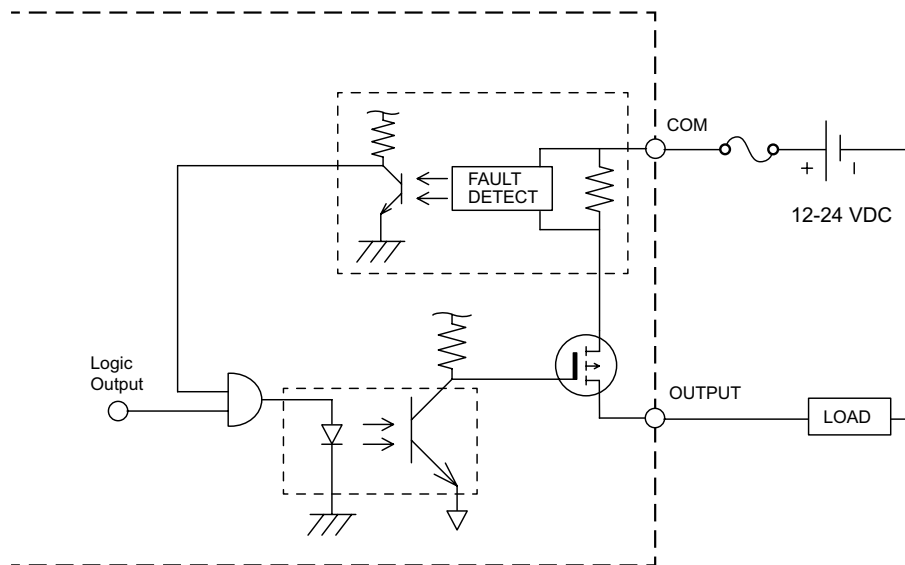

NOTE: When the high speed outputs are in an overcurrent situation, the Common terminal Red LED is on. The output LEDs will remain operational even though the output circuitry is turned off and no power is flowing. This condition is not reported to the CPU.

BX-DM1-36ER Wiring

This MPU is made up of 36 discrete I/O points. The connections are grouped as follows:

- 20 discrete inputs - sinking/sourcing; rated for 12–24 VAC/VDC. They are located along the bottom of the unit; configured in five (5) groups of 5 terminals, each comprised of 4 inputs and an isolated common.
- 16 discrete outputs - Form A Relay (SPST); rated 12–48 VDC/ 24–240 VAC. They are located along the top of the unit starting to the right of the 24VDC auxiliary output terminals. The outputs are configured in four (4) groups of 5 terminals, each comprised of 4 outputs and an isolated common.

This MPU requires an external 120–240 VAC power supply. The AC power supply connection and the 24VDC auxiliary output supply terminals are located on the top left side of the unit.



WARNING: No analog I/O is included on this unit. The 5 terminals to the right of the input and output rails are not used. These terminals are not internally connected. DO NOT CONNECT ANYTHING TO THESE TERMINALS!

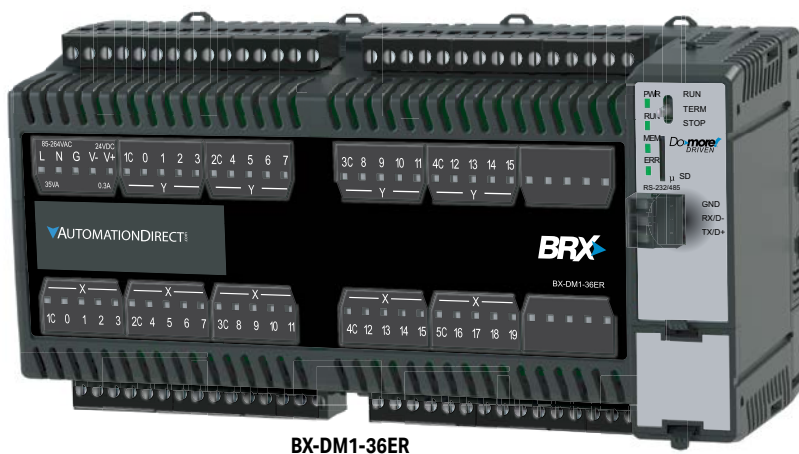

BX-DM1-36ER



NOTE: Eight (8) Expansion Modules can be connected to extend I/O capacity, as long as the MPU power budget is not exceeded.

BX-DM1-36ER Wiring, Continued

Power Supply Specifications

Power Supply Specifications	
Nominal Voltage Range	120–240 VAC
Input Voltage Range (Tolerance)	85–264 VAC
Rated Operating Frequency	47–63 Hz
Maximum Input Power	40VA
Cold Start Inrush Current	1.5 A, 2ms
Maximum Inrush Current (Hot Start)	1.5 A, 2ms
Internal Input Fuse Protection	Micro fuse 250V, 2A Non-replaceable
Acceptable External Power Drop Time	10ms
Under Input Voltage Lock-out	80VAC
Input Transient Protection	Input choke and line filter
Heat Dissipation	24.9 W Max
Isolated User 24VDC Output	24VDC @ 0.3 A max, <1V P-P Ripple, Integrated self-resetting short circuit protection
Voltage Withstand (dielectric)	1500VAC Power Inputs to Ground applied for 1 minute 1500VAC Ground to 24VDC Output applied for 1 minute
Insulation Resistance	>10MΩ @ 500VDC
Software Version Required	Do-more! Designer version 2.0 or later

Power Supply Connections

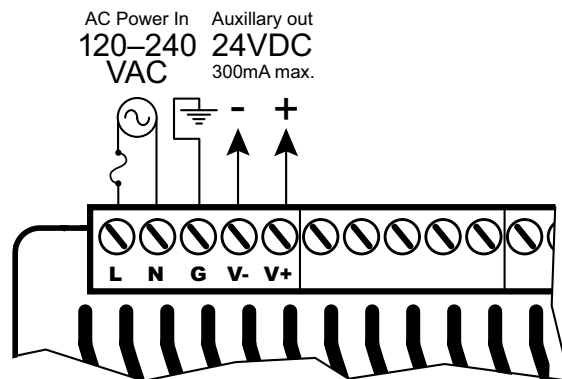

WARNING: Do not exceed the 24VDC auxiliary power supply load limit of 300mA.



WARNING: The BRX System **MUST** have a proper earth ground. Do not operate the BRX MPU without proper earth grounding.

BX-DM1-36ER Wiring, Continued

Discrete Input Specifications

Discrete Input Specifications			
Input Type	Sink/Source		
Total Inputs per Module	20		
Commons	5 (4 points/common) Isolated		
Nominal Voltage Range	12–24 VAC/VDC		
Input Voltage Range	9–30 VAC/VDC		
Maximum Voltage	30 VAC/VDC		
DC Frequency	0–250 kHz - High-speed		
Minimum Pulse Width	0.5 μ s - High-speed		
AC Frequency	47–63 Hz ²		
Input Impedance	3k Ω @ 24VDC		
Input Current (typical)	6mA @ 24 VAC/VDC		
Maximum Input Current	12mA @ 30 VAC/VDC		
ON Voltage Level	> 9.0 VAC/VDC		
OFF Voltage Level	< 2.0 VAC/VDC		
Maximum OFF Current	1.5 mA		
Status Indicators	Logic Side, Green		
Input Details			
Input Type	High-Speed DC		Standard ¹
Location	X0...X9		X10...X19
OFF to ON Response	DC	< 2 μ s	2ms
	AC	–	10ms ²
ON to OFF Response	DC	< 2 μ s	2ms
	AC	–	10ms ²
Maximum Switching Frequency	DC	250kHz	
	AC	~ 30Hz	

- 1. All inputs may be used as standard inputs. Only the first 10 inputs (X0...X9) are capable of high-speed DC operation.*
- 2. 60Hz to 240Hz filter should be set in the software when using an AC line signal.*

BX-DM1-36ER Wiring, Continued

Discrete Input Connection Options

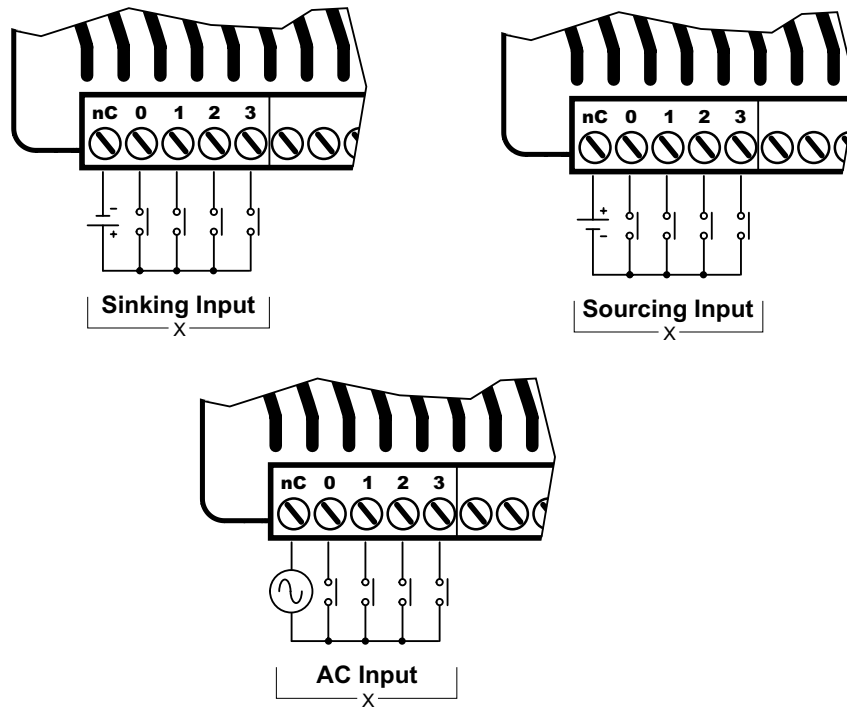

Discrete Input Internal Circuitry *

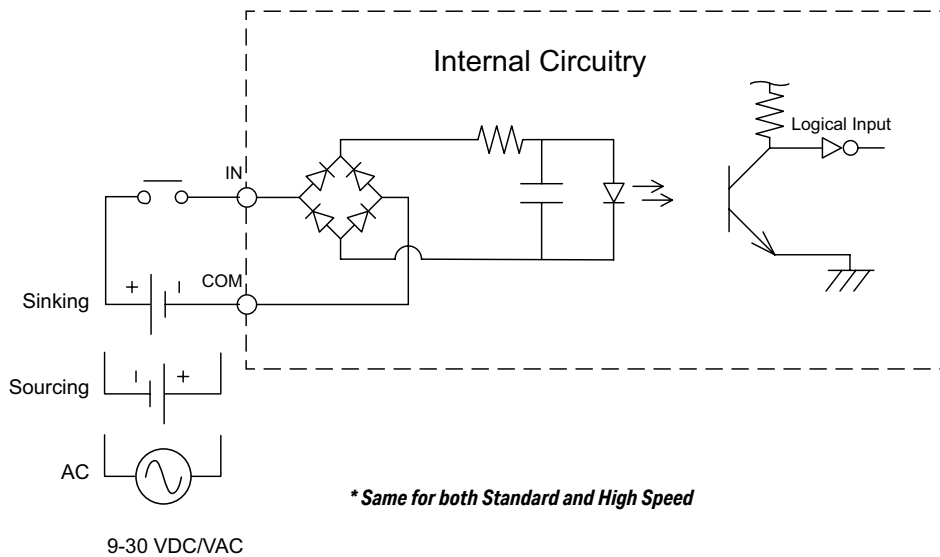

BX-DM1-36ER Wiring, Continued

Discrete Output Specifications

Discrete Output Specifications	
Output Type	Relay Form A (SPST)
Total Outputs per Module	16
Commons	4 (4 points/common) Isolated
Maximum Current per Common	8A
Nominal Voltage Range	12–48 VDC 24–240 VAC
Operating Voltage Range	5–60 VDC 5–264 VAC
Maximum Voltage	60VDC 264VAC
Minimum Output Current	0.1 mA @ 24VDC 0.1 mA @ 24VAC
Maximum Output Current	2A
Maximum Inrush Current	5A for 50ms
Maximum Leakage Current	1 μ A (DC), 300 μ A (AC) due to RC snubber circuit
ON Voltage Drop	0.2 V Max
Status Indicators	Logic Side, Green
Output Details	
Output Type	Standard
Location	Y0...Y15
ON-OFF Response	<10ms
OFF-ON Response	<10ms
Maximum Switching Frequency	10Hz
Relay Cycle Life	5 million operations
Mechanical Endurance	120,000 operations
Electrical Endurance	
Fuse Type	User-supplied external fuse

BX-DM1-36ER Wiring, Continued

Discrete Output Connection Options

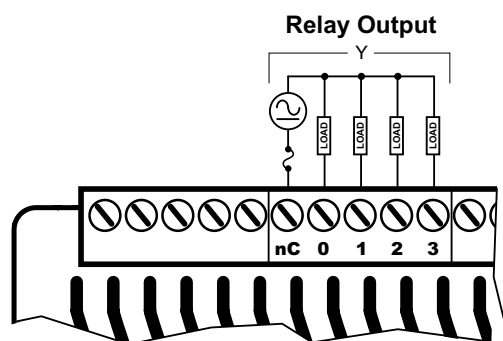

Discrete Standard Output Internal Circuitry

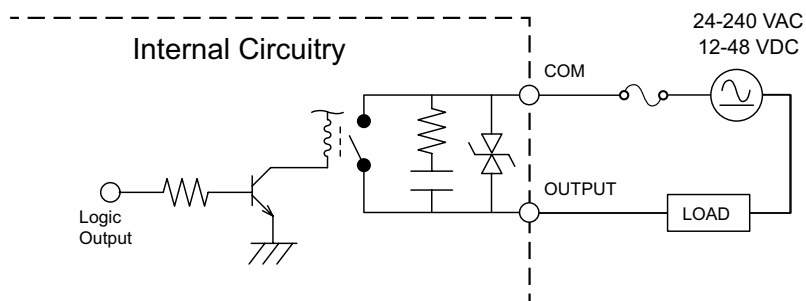

BX-DM1-36ER-D Wiring

This MPU is made up of 36 discrete I/O points. The connections are grouped as follows:

- 20 discrete inputs - sinking/sourcing; rated for 12–24 VAC/VDC. They are located along the bottom of the unit; configured in five (5) groups of 5 terminals, each comprised of 4 inputs and an isolated common.
- 16 discrete outputs - Form A Relay (SPST); rated 12–48 VDC/ 24–240 VAC. They are located along the top of the unit starting to the right of the 24VDC external power supply terminals. The outputs are configured in four (4) groups of 5 terminals, each comprised of 4 outputs and an isolated common.

This MPU requires an external 12–24 VDC power supply. The DC power supply connection is located on the top left side of the unit. There is no 24VDC auxiliary output supply



WARNING: No analog I/O is included on this unit. The 5 terminals to the right of the input and output rails are not used. These terminals are not internally connected. DO NOT CONNECT ANYTHING TO THESE TERMINALS!

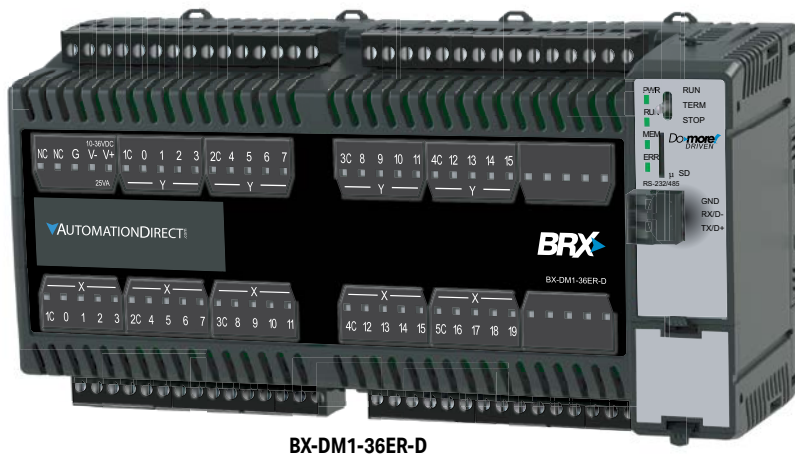

BX-DM1-36ER-D



NOTE: Eight (8) Expansion Modules can be connected to extend I/O capacity, as long as the MPU power budget is not exceeded.

BX-DM1-36ER-D Wiring, Continued

Power Supply Specifications

Power Supply Specifications	
Nominal Voltage Range*	12–24 VDC
Input Voltage Range (Tolerance)*	10–36 VDC
Maximum Input Voltage Ripple	< ±10%
Maximum Input Power	30W
Cold Start Inrush Current	5A, 2ms
Maximum Inrush Current (Hot Start)	5A, 2ms
Internal Input Protection	Reverse polarity protection and undervoltage lockout via transistor circuit
Acceptable External Power Drop Time	10ms
Under Input Voltage Lock-out	<9VDC
Heat Dissipation	22.7 W Max
Isolated User 24VDC Output	None
Voltage Withstand (dielectric)	1500VAC power Inputs to ground applied for 1 minute
Insulation Resistance	>10MΩ @ 500VDC
Software Version Required	Do-more! Designer version 2.0 or later

* Class 2 or LPS Power Supply required.

Power Supply Connections

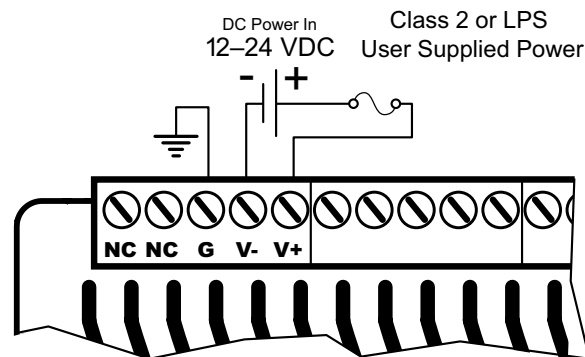

WARNING: No External AC power supply needed on this unit. The two terminals marked "NC" are not used. These terminals are not internally connected. **DO NOT CONNECT ANYTHING TO THESE TERMINALS!**



WARNING: The BRX System **MUST** have a proper earth ground. Do not operate the BRX MPU without proper earth grounding.

BX-DM1-36ER-D Wiring, Continued

Discrete Input Specifications

Discrete Input Specifications			
Input Type	Sink/Source		
Total Inputs per Module	20		
Commons	5 (4 points/common) Isolated		
Nominal Voltage Range	12–24 VAC/VDC		
Input Voltage Range	9–30 VAC/VDC		
Maximum Voltage	30 VAC/VDC		
DC Frequency	0–250 kHz - High-speed		
Minimum Pulse Width	0.5 μ s - High-speed		
AC Frequency	47–63 Hz ²		
Input Impedance	3k Ω @ 24VDC		
Input Current (typical)	6mA @ 24 VAC/VDC		
Maximum Input Current	12mA @ 30 VAC/VDC		
ON Voltage Level	> 9.0 VAC/VDC		
OFF Voltage Level	< 2.0 VAC/VDC		
Maximum OFF Current	1.5 mA		
Status Indicators	Logic Side, Green		
Input Details			
Input Type		High-Speed DC	Standard ¹
Location		X0...X9	X10...X19
OFF to ON Response	DC	< 2 μ s	2ms
	AC	–	10ms ²
ON to OFF Response	DC	< 2 μ s	2ms
	AC	–	10ms ²
Maximum Switching Frequency	DC	250kHz	
	AC	~ 30Hz	

1. All inputs may be used as standard inputs. Only the first 10 inputs (X0...X9) are capable of high-speed DC operation.

2. 60Hz to 240Hz filter should be set in the software when using an AC line signal.

BX-DM1-36ER-D Wiring, Continued

Discrete Input Connection Options

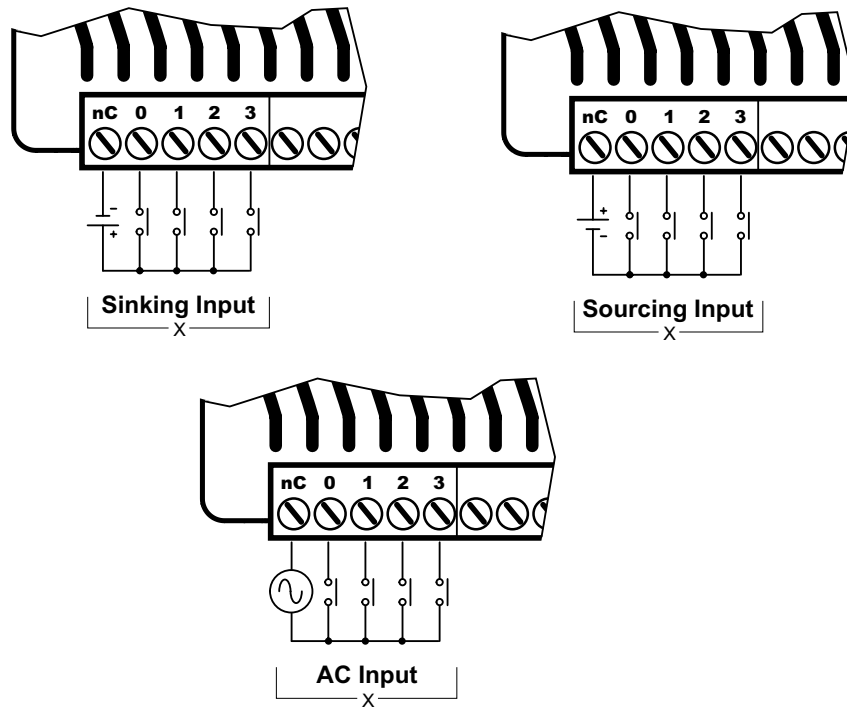

Discrete Input Internal Circuitry *

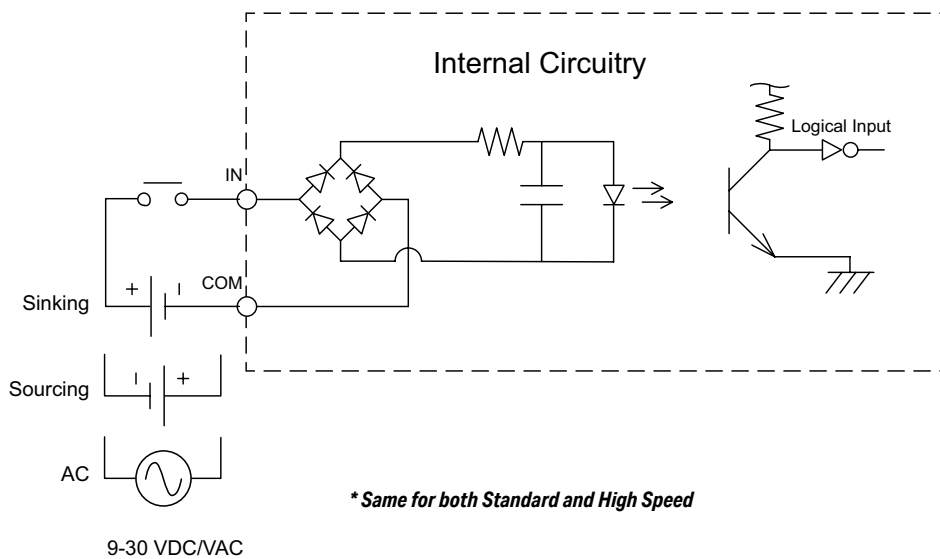

BX-DM1-36ER-D Wiring, Continued

Discrete Output Specifications

Discrete Output Specifications	
Output Type	Relay Form A (SPST)
Total Outputs per Module	16
Commons	4 (4 points/common) Isolated
Maximum Current per Common	8A
Nominal Voltage Range	12–48 VDC 24–240 VAC
Operating Voltage Range	5–60 VDC 5–264 VAC
Maximum Voltage	60VDC 264VAC
Minimum Output Current	0.1 mA @ 24VDC 0.1 mA @ 24VAC
Maximum Output Current	2A
Maximum Inrush Current	5A for 50ms
Maximum Leakage Current	1 μ A (DC), 300 μ A (AC) due to RC snubber circuit
ON Voltage Drop	0.2 V Max
Status Indicators	Logic Side, Green
Output Details	
Output Type	Standard
Location	Y0...Y15
ON-OFF Response	<10ms
OFF-ON Response	<10ms
Maximum Switching Frequency	10Hz
Relay Cycle Life	5 million operations
Mechanical Endurance	120,000 operations
Electrical Endurance	
Fuse Type	User-supplied external fuse

BX-DM1-36ER-D Wiring, Continued

Discrete Output Connection Options

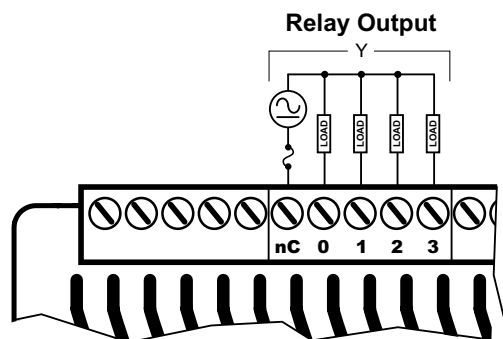

Discrete Standard Output Internal Circuitry

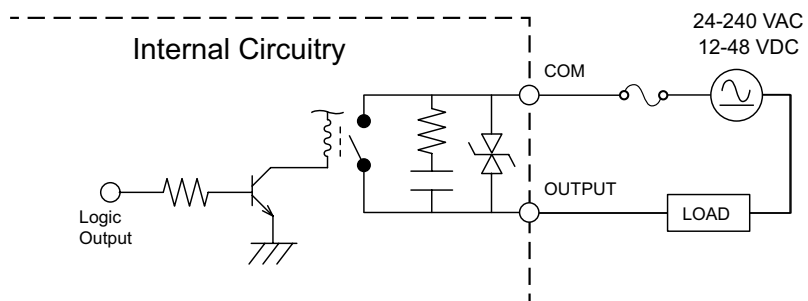

BX-DM1-36AR Wiring

This MPU is made up of 36 discrete I/O points. The connections are grouped as follows:

- 20 discrete inputs - AC rated for 120–240 VAC. They are located along the bottom of the unit; configured in five (5) groups of 5 terminals, each comprised of 4 inputs and an isolated common.
- 16 discrete outputs - Form A Relay (SPST); rated 12–48 VDC/ 24–240 VAC. They are located along the top of the unit starting to the right of the 24VDC auxiliary output terminals. The outputs are configured in four (4) groups of 5 terminals, each comprised of 4 outputs and an isolated common.

This MPU requires an external 120–240 VAC power supply. The AC power supply connection and the 24VDC auxiliary output supply terminals are located on the top left side of the unit.



WARNING: No analog I/O is included on this unit. The 5 terminals to the right of the input and output rails are not used. These terminals are not internally connected. DO NOT CONNECT ANYTHING TO THESE TERMINALS!

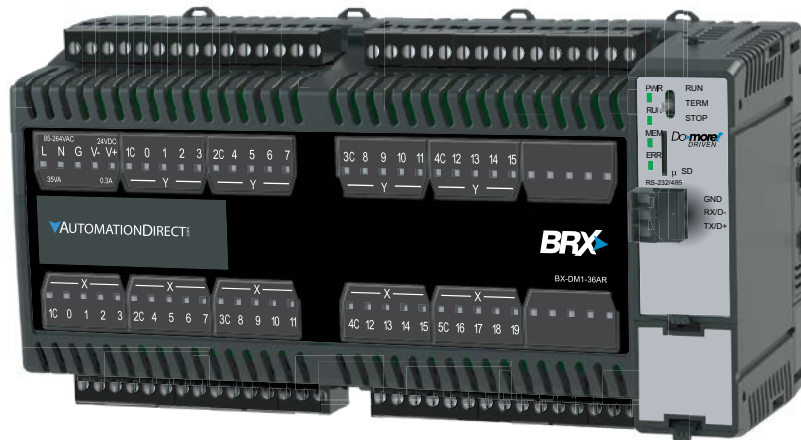

BX-DM1-36AR



NOTE: Eight (8) Expansion Modules can be connected to extend I/O capacity, as long as the MPU power budget is not exceeded.

BX-DM1-36AR Wiring, Continued

Power Supply Specifications

Power Supply Specifications	
Nominal Voltage Range	120–240 VAC
Input Voltage Range (Tolerance)	85–264 VAC
Rated Operating Frequency	47–63 Hz
Maximum Input Power	40VA
Cold Start Inrush Current	1.5 A, 2ms
Maximum Inrush Current (Hot Start)	1.5 A, 2ms
Internal Input Fuse Protection	Micro fuse 250V, 2A Non-replaceable
Acceptable External Power Drop Time	10ms
Under Input Voltage Lock-out	80VAC
Input Transient Protection	Input choke and line filter
Heat Dissipation	24.1 W Max
Isolated User 24VDC Output	24VDC @ 0.3 A max, <1V P-P Ripple, Integrated self-resetting short circuit protection
Voltage Withstand (dielectric)	1500VAC Power Inputs to Ground applied for 1 minute 1500VAC Ground to 24VDC Output applied for 1 minute
Insulation Resistance	>10MΩ @ 500VDC
Software Version Required	Do-more! Designer version 2.0 or later

Power Supply Connections

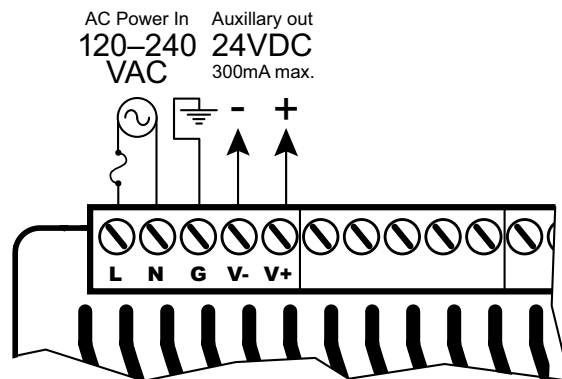

WARNING: Do not exceed the 24VDC auxiliary power supply load limit of 300mA.



WARNING: The BRX System **MUST** have a proper earth ground. Do not operate the BRX MPU without proper earth grounding.

BX-DM1-36AR Wiring, Continued

Discrete Input Specifications

Discrete Input Specifications	
Input Type	AC
Total Inputs per Module	20
Commons	5 (4 points/common) Isolated
Nominal Voltage Range	120–240 VAC
Input Voltage Range	85–264 VAC
Maximum Voltage	264VAC RMS
AC Frequency	47–63 Hz
Input Impedance	15k Ω
Input Current (typical)	9mA @ 120VAC, 13mA @ 220VAC
Maximum Input Current	14mA @ 120VAC, 20mA @ 220VAC
ON Voltage Level	> 85VAC
OFF Voltage Level	< 40VAC
Maximum OFF Current	2.5 mA
Status Indicators	Logic Side, Green
Input Details	
Input Type	Standard
Location	X0...X19
OFF - ON Response	10ms
ON - OFF Response	10ms
Maximum Switch Frequency	~ 30Hz

Discrete Input Connection Options

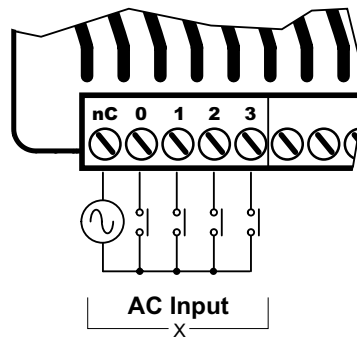

Discrete Input Internal Circuitry

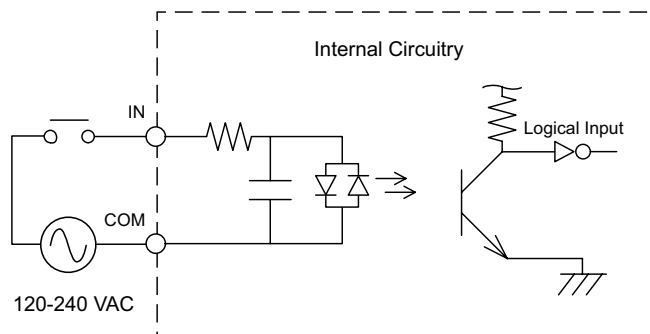

BX-DM1-36AR Wiring, Continued

Discrete Output Specifications

Discrete Output Specifications	
Output Type	Relay Form A (SPST)
Total Outputs per Module	16
Commons	4 (4 points/common) Isolated
Maximum Current per Common	8A
Nominal Voltage Range	12–48 VDC 24–240 VAC
Operating Voltage Range	5–60 VDC 5–264 VAC
Maximum Voltage	60VDC 264VAC
Minimum Output Current	0.1 mA @ 24VDC 0.1 mA @ 24VAC
Maximum Output Current	2A
Maximum Inrush Current	5A for 50ms
Maximum Leakage Current	1 μ A (DC), 300 μ A (AC) due to RC snubber circuit
ON Voltage Drop	0.2 V Max
Status Indicators	Logic Side, Green
Output Details	
Output Type	Standard
Location	Y0...Y15
ON-OFF Response	<10ms
OFF-ON Response	<10ms
Maximum Switching Frequency	10Hz
Relay Cycle Life	5 million operations
Mechanical Endurance	120,000 operations
Electrical Endurance	
Fuse Type	User-supplied external fuse

BX-DM1-36AR Wiring, Continued

Discrete Output Connection Options

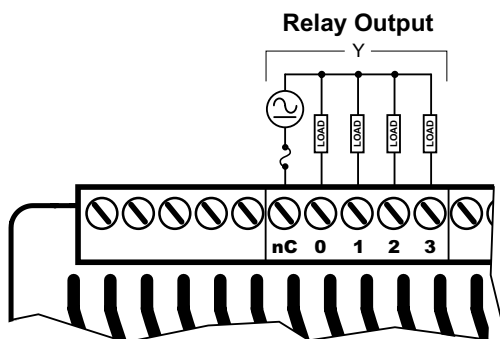

Discrete Standard Output Internal Circuitry

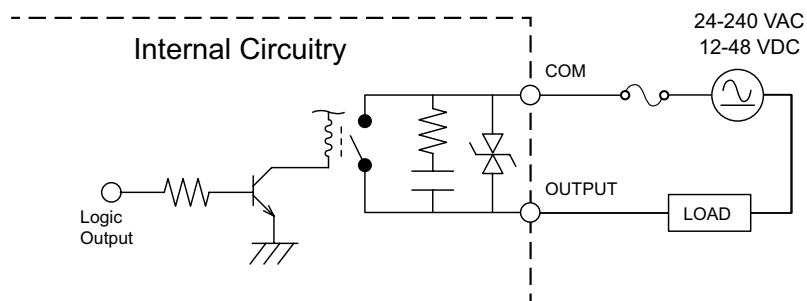

BX 36E Micro PLC Units (MPUs)

BX-DM1E-36ED13 Wiring

This MPU is made up of 36 discrete I/O points. The connections are grouped as follows:

- 20 discrete inputs - sinking/sourcing; rated for 12–24 VAC/VDC. They are located along the bottom of the unit; configured in five (5) groups of 5 terminals, each comprised of 4 inputs and an isolated common.
- 16 discrete outputs - sinking; rated at 12–24 VDC. They are located along the top of the unit starting to the right of the 24VDC auxiliary output terminals. The outputs are configured in four (4) groups of 5 terminals, each comprised of 4 outputs and an isolated common.
- 4 analog inputs and 2 analog outputs. The analog inputs are located along the bottom of the unit to the right of the discrete inputs. The analog inputs are grouped together on 5 terminals consisting of 4 input and a shared analog input common. The analog outputs are located along the top of the unit to the right of the discrete outputs. The analog outputs are grouped together on 5 terminals consisting of 2 outputs and 3 shared analog output common terminals. The analogs share these common features:
 - current or voltage selectable through software
 - 16-bit resolution @ $\pm 20\text{mA}$, $\pm 10\text{VDC}$
 - current signal ranges of 4–20 mA, $\pm 20\text{mA}$
 - voltage signal ranges of 0–5 VDC, 0–10 VDC, $\pm 5\text{VDC}$, $\pm 10\text{VDC}$.

This MPU requires an external 120–240 VAC power supply. The AC power supply connection and the 24VDC auxiliary output supply terminals are located on the top left side of the unit.

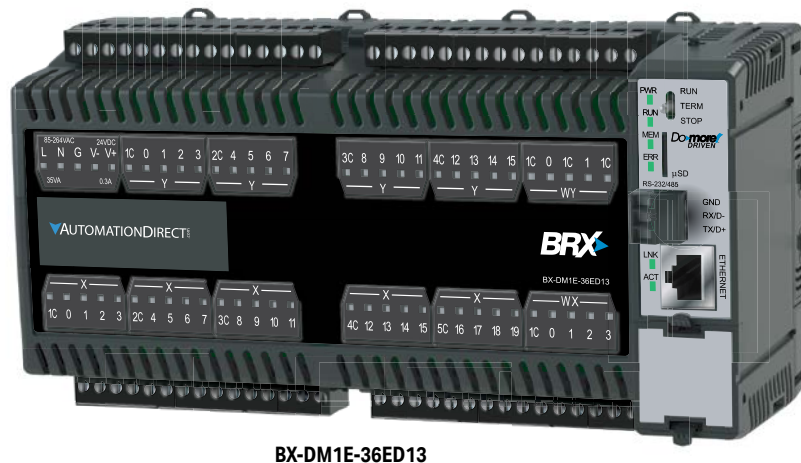

BX-DM1E-36ED13



NOTE: Eight (8) Expansion Modules can be connected to extend I/O capacity.

BX-DM1E-36ED13 Wiring, Continued

Power Supply Specifications

Power Supply Specifications	
Nominal Voltage Range	120–240 VAC
Input Voltage Range (Tolerance)	85–264 VAC
Rated Operating Frequency	47–63 Hz
Maximum Input Power	40VA
Cold Start Inrush Current	1.5 A, 2ms
Maximum Inrush Current (Hot Start)	1.5 A, 2ms
Internal Input Fuse Protection	Micro fuse 250V, 2A Non-replaceable
Acceptable External Power Drop Time	10ms
Under Input Voltage Lock-out	80VAC
Input Transient Protection	Input choke and line filter
Heat Dissipation	24.4 W Max
Isolated User 24VDC Output	24VDC @ 0.3 A max, <1V P-P Ripple, Integrated self-resetting short circuit protection
Voltage Withstand (dielectric)	1500VAC Power Inputs to Ground applied for 1 minute 1500VAC Ground to 24VDC Output applied for 1 minute
Insulation Resistance	>10M Ω @ 500VDC
Software Version Required	Do-more! Designer version 2.0 or later

Power Supply Connections

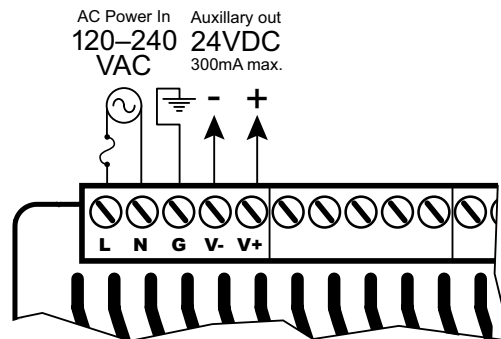

WARNING: Do not exceed the 24VDC auxiliary power supply load limit of 300mA.



WARNING: The BRX System **MUST** have a proper earth ground. Do not operate the BRX MPU without proper earth grounding.

BX-DM1E-36ED13 Wiring, Continued

Discrete Input Specifications

Discrete Input Specifications		
Input Type	Sink/Source	
Total Inputs per Module	20	
Commons	5 (4 points/common) Isolated	
Nominal Voltage Range	12–24 VAC/VDC	
Input Voltage Range	9–30 VAC/VDC	
Maximum Voltage	30 VAC/VDC	
DC Frequency	0–250 kHz - High-speed	
Minimum Pulse Width	0.5 μ s - High-speed	
AC Frequency	47–63 Hz ²	
Input Impedance	3k Ω @ 24VDC	
Input Current (typical)	6mA @ 24 VAC/VDC	
Maximum Input Current	12mA @ 30 VAC/VDC	
ON Voltage Level	> 9.0 VAC/VDC	
OFF Voltage Level	< 2.0 VAC/VDC	
Maximum OFF Current	1.5 mA	
Status Indicators	Logic Side, Green	
Input Details		
Input Type	High-Speed DC	Standard ¹
Location	X0...X9	X10...X19
OFF to ON Response	DC	< 2 μ s
	AC	–
ON to OFF Response	DC	< 2 μ s
	AC	–
Maximum Switching Frequency	DC	250kHz
	AC	~ 30Hz

1. All inputs may be used as standard inputs. Only the first 10 inputs (X0...X9) are capable of high-speed DC operation.

2. 60Hz to 240Hz filter should be set in the software when using an AC line signal.

BX-DM1E-36ED13 Wiring, Continued

Discrete Input Connection Options

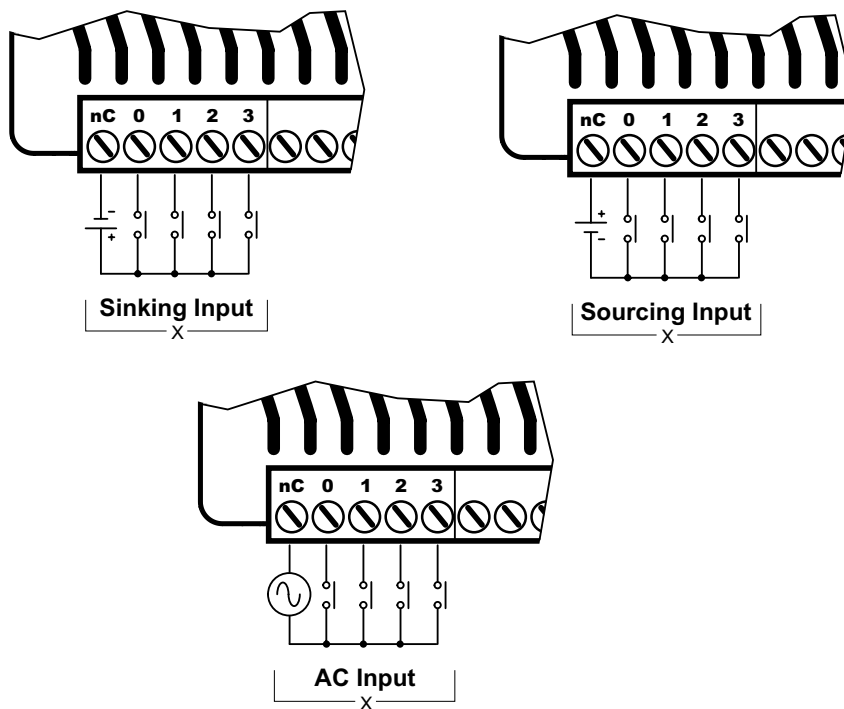

Discrete Input Internal Circuitry *

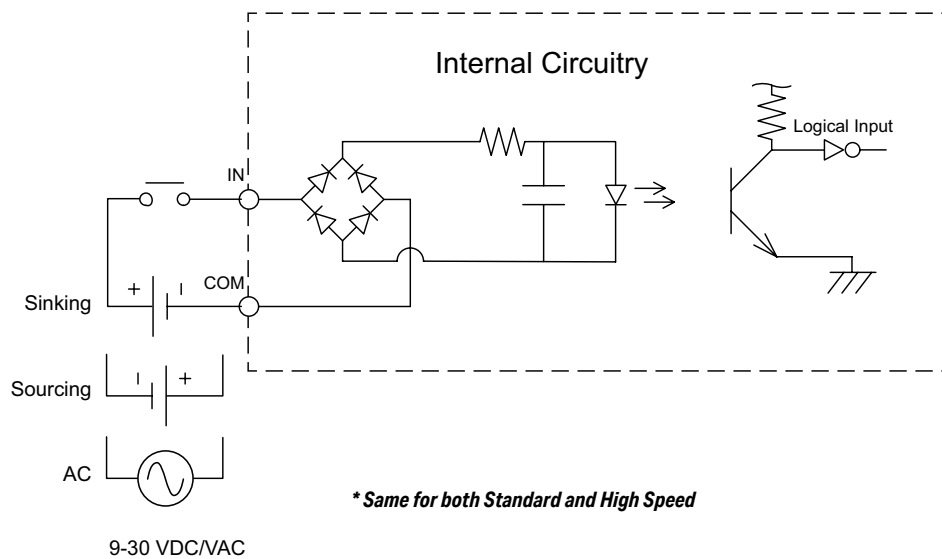

BX-DM1E-36ED13 Wiring, Continued

Discrete Output Specifications

Discrete Output Specifications		
Output Type	Sinking	
Total Outputs per Module	16	
Commons	4 (4 points/common) Isolated	
Maximum Current per Common	2A	
Nominal Voltage Range	12–24 VDC	
Operating Voltage Range	5–36 VDC	
Maximum Voltage	36VDC	
Minimum Output Current	0.1 mA @ 24VDC	
Maximum Output Current	0.5 A per output No derating over temperature range	
Maximum Inrush Current	5A for 50ms	
Maximum Leakage Current	10 μ A	
ON Voltage Drop	0.05 VDC	
Status Indicators	Logic Side, Green	
Output Details		
Output Type	High-Speed	Standard ¹
Location	Y0...Y7	Y8...Y15
OFF to ON Response	< 2 μ s	< 5ms
ON to OFF Response	< 2 μ s	< 2ms
Maximum Switching Frequency	1m cable - 250kHz 10m cable - 100kHz	~100Hz
Overcurrent, Short Circuit Protection and Short to Ground	Current limit by Common Group, self-resetting	N/A
Overcurrent Trip Level ²	Between 4A and 8A	N/A
Fuse Type	User-supplied external fuse	

- 1. All outputs may be used as standard outputs. Only the first 8 outputs (Y0...Y7) are capable of high-speed DC operation.*
- 2. When the high-speed outputs are in an overcurrent situation, the Common terminal Red LED is on. The output LEDs will remain operational even though the output circuitry is turned off and no power is flowing. This condition is not reported to the CPU.*

BX-DM1E-36ED13 Wiring, continued

Discrete Output Connection Options

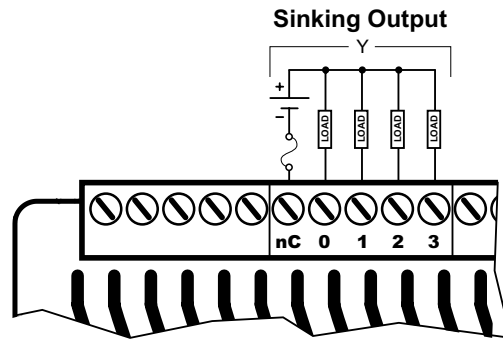

Discrete Standard Output Internal Circuitry

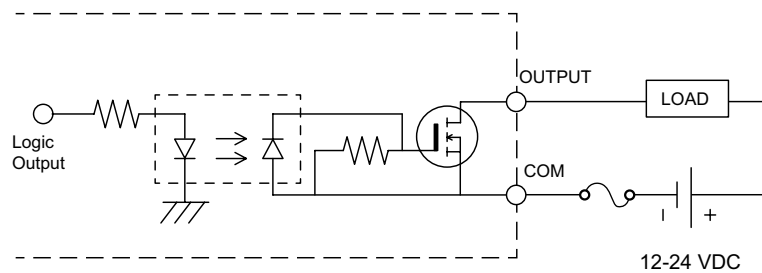

Discrete High-Speed Output Internal Circuitry

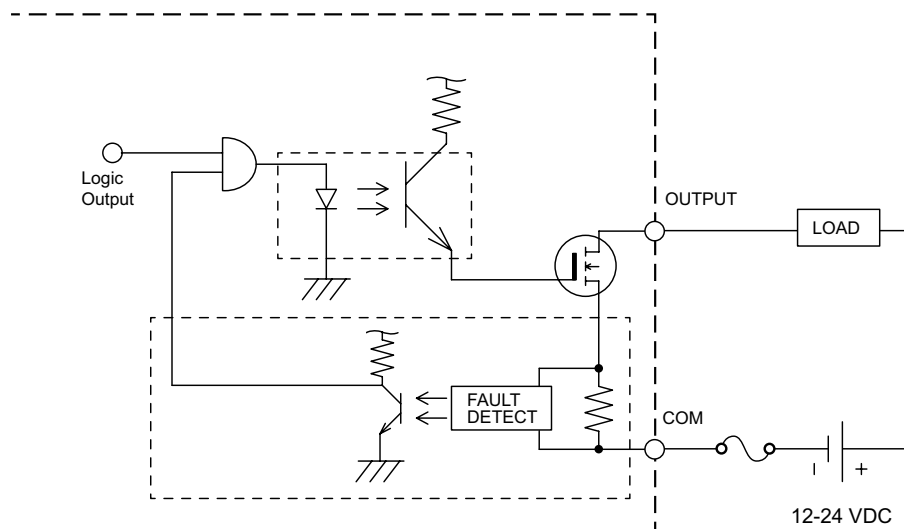

NOTE: When the high speed outputs are in an overcurrent situation, the Common terminal Red LED is on. The output LEDs will remain operational even though the output circuitry is turned off and no power is flowing. This condition is not reported to the CPU.

BX-DM1E-36ED13 Wiring, Continued

Analog Input Specifications

Analog Input Specifications	
Inputs per Module	4
Commons	1
Input Voltage Range *	Software Selectable $\pm 10V$, $\pm 5V$, 0–10 V, 0–5 V
Input Current Range *	Software Selectable $\pm 20mA$, 4–20 mA
Resolution $\pm 10V$, $\pm 20mA$ $\pm 5V$ 0–5 V 4–20 mA 0–10 V	16 bits (0–65535 counts) 15 bits (0–32767 counts) 14 bits (0–16383 counts) ~15 bits (6553–32767 counts) 15 bits (0–32767 counts)
Input Impedance Voltage Modes	100k Ω
Absolute Maximum Input, Voltage Mode	$\pm 30V$
Input Impedance Current Modes	249 Ω
Absolute Maximum Input, Current Mode	$\pm 40mA$ sustained, $\pm 100mA$ for < 5s
Conversion Time	1.2 ms
Input Stability	0.02% of Full Hardware Range = 13 Counts
Full Scale Calibration Error	0.05% of Full Hardware Range = 33 Counts
Offset Calibration Error	0.01% of Full Hardware Range = 7 Counts
Accuracy vs Temperature Error	0.05% of Full Hardware Range = 33 Counts
Maximum Linearity Error (End to End)	0.1% of Full Hardware Range = 66 Counts
Maximum Inaccuracy	0.2% of Full Hardware Range = 131 Counts
Fuse Type	User-supplied external fuse

* Software selectable per channel

BX-DM1E-36ED13 Wiring, Continued

Analog Input Connection Options

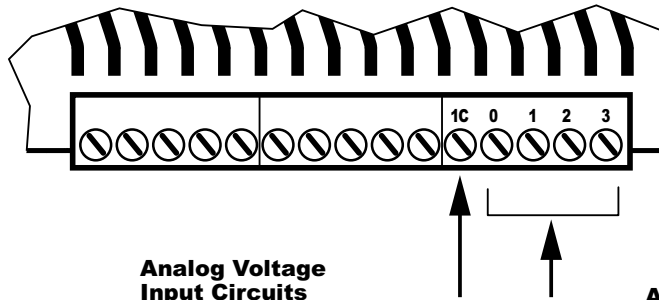

Analog Voltage Input Circuits

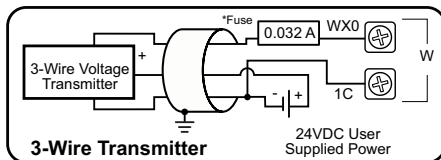
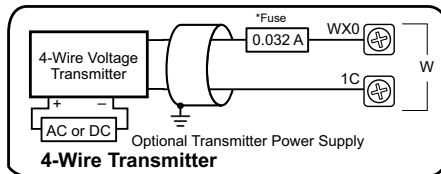

NOTE: Shield should be connected only at one end, to ground at the source device.

Analog Current Sinking Input Circuits

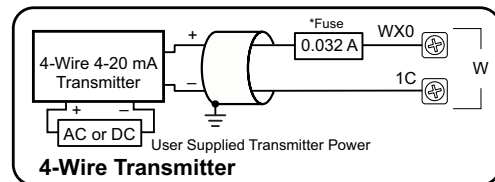
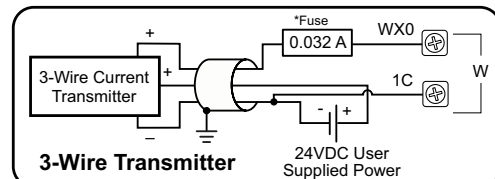
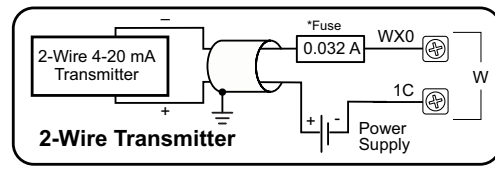

NOTE: Shield should be connected only at one end, to ground at the source device.



NOTE: An Edison S500-32-R 0.032A fast-acting fuse is recommended for all analog voltage inputs, analog outputs, and current loops.

BX-DM1E-36ED13 Wiring, Continued

Analog Output Specifications

Analog Output Specifications	
Outputs per Module	2
Commons	3
Output Voltage Range *	Software Selectable $\pm 10V$, $\pm 5V$, $0-10 V$, $0-5 V$
Output Current Range *	Software Selectable $\pm 20mA$, $4-20 mA$
Resolution $\pm 10V$, $\pm 20mA$ $\pm 5V$ $0-5 V$ $4-20 mA$ $0-10 V$	16 bits (0–65535 counts) 15 bits (0–32767 counts) 14 bits (0–16383 counts) ~15 bits (6553–32767 counts) 15 bits (0–32767 counts)
Minimum Voltage Load Impedance	1k Ω
Maximum Current Load Impedance	500 Ω
Maximum Rating	Continuous Short Circuit Protected
Settling Time	< 1ms
Output Stability	0.02% of Full Hardware Range = 13 Counts
Full Scale Calibration Error	0.05% of Full Hardware Range = 33 Counts
Offset Calibration Error	0.01% of Full Hardware Range = 7 Counts
Accuracy vs Temperature Error	0.05% of Full Hardware Range = 33 Counts
Maximum Linearity Error (End to End)	0.1% of Full Hardware Range = 66 Counts
Maximum Inaccuracy	0.2% of Full Hardware Range = 131 Counts
Fuse Type	User-supplied external fuse

* Software selectable per channel

Analog Output Connection Options

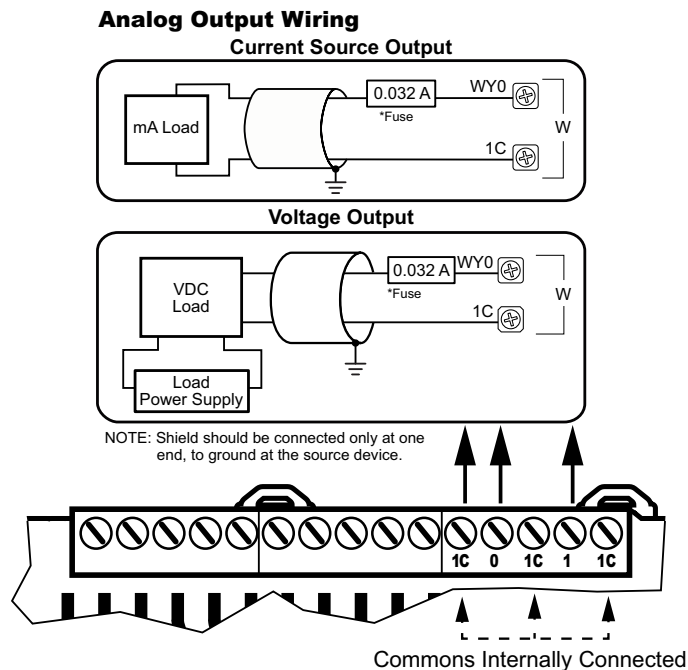

NOTE: An Edison S500-32-R 0.032A fast-acting fuse is recommended for all analog voltage inputs, analog outputs, and current loops.

BX-DM1E-36ED13-D Wiring

This MPU is made up of 36 discrete I/O points. The connections are grouped as follows:

- 20 discrete inputs - sinking/sourcing; rated for 12–24 VAC/VDC. They are located along the bottom of the unit; configured in five (5) groups of 5 terminals, each comprised of 4 inputs and an isolated common.
- 16 discrete outputs - sinking; rated at 12–24 VDC. They are located along the top of the unit starting to the right of the 24VDC external power supply terminals. The outputs are configured in four (4) groups of five (5) terminals, each comprised of four (4) outputs and an isolated common.
- 4 analog inputs and 2 analog outputs. The analog inputs are located along the bottom of the unit to the right of the discrete inputs. The analog inputs are grouped together on 5 terminals consisting of 4 input and a shared analog input common. The analog outputs are located along the top of the unit to the right of the discrete outputs. The analog outputs are grouped together on 5 terminals consisting of 2 outputs and 3 shared analog output common terminals. The analogs share these common features:
 - current or voltage selectable through software,
 - 16-bit resolution @ ± 20 mA, ± 10 VDC
 - current signal ranges of 4–20 mA, ± 20 mA,
 - voltage signal ranges of 0–5 VDC, 0–10 VDC, ± 5 VDC, ± 10 VDC.

This MPU requires an external 12–24 VDC power supply. The DC power supply connection is located on the top left side of the unit. There is no 24VDC auxiliary output supply.

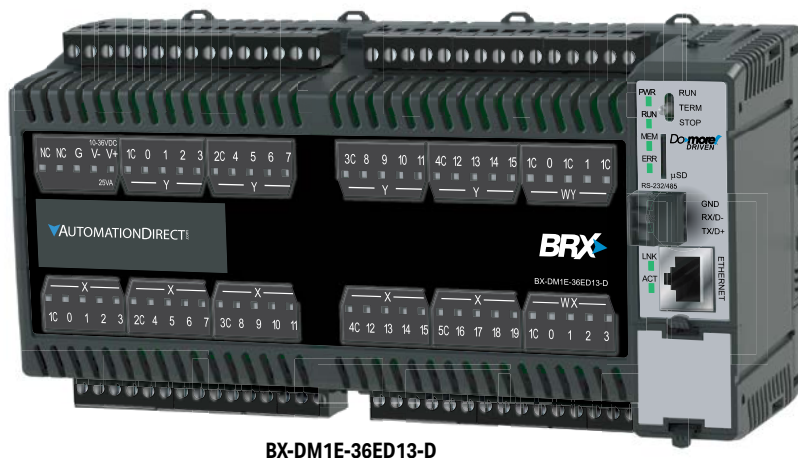

BX-DM1E-36ED13-D



NOTE: Eight (8) Expansion Modules can be connected to extend I/O capacity.

BX-DM1E-36ED13-D Wiring, Continued

Power Supply Specifications

Power Supply Specifications	
Nominal Voltage Range*	12–24 VDC
Input Voltage Range (Tolerance)*	10–36 VDC
Maximum Input Voltage Ripple	< ±10%
Maximum Input Power	30W
Cold Start Inrush Current	5A, 2ms
Maximum Inrush Current (Hot Start)	5A, 2ms
Internal Input Protection	Reverse polarity protection and undervoltage lockout via transistor circuit
Acceptable External Power Drop Time	10ms
Under Input Voltage Lock-out	<9VDC
Heat Dissipation	22.1 W Max
Isolated User 24VDC Output	None
Voltage Withstand (dielectric)	1500VAC power Inputs to ground applied for 1 minute
Insulation Resistance	>10MΩ @ 500VDC
Software Version Required	Do-more! Designer version 2.0 or later

* Class 2 or LPS Power Supply required.

Power Supply Connections

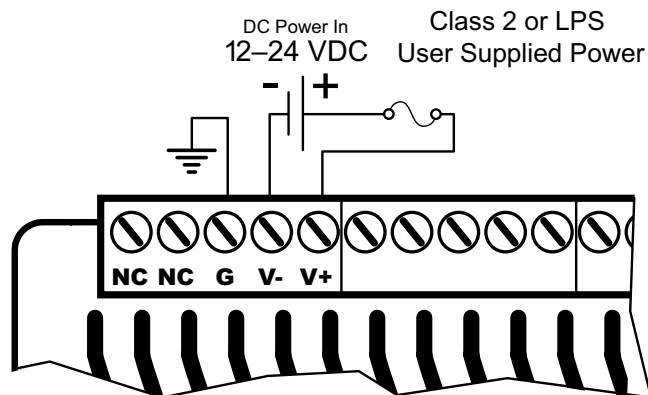

WARNING: No External AC power supply needed on this unit. The two terminals marked "NC" are not used. These terminals are not internally connected. **DO NOT CONNECT ANYTHING TO THESE TERMINALS!**



WARNING: The BRX System **MUST** have a proper earth ground. Do not operate the BRX MPU without proper earth grounding.

BX-DM1E-36ED13-D Wiring, Continued

Discrete Input Specifications

Discrete Input Specifications			
Input Type	Sink/Source		
Total Inputs per Module	20		
Commons	5 (4 points/common) Isolated		
Nominal Voltage Range	12–24 VAC/VDC		
Input Voltage Range	9–30 VAC/VDC		
Maximum Voltage	30 VAC/VDC		
DC Frequency	0–250 kHz - High-speed		
Minimum Pulse Width	0.5 μ s - High-speed		
AC Frequency	47–63 Hz ²		
Input Impedance	3k Ω @ 24VDC		
Input Current (typical)	6mA @ 24 VAC/VDC		
Maximum Input Current	12mA @ 30 VAC/VDC		
ON Voltage Level	> 9.0 VAC/VDC		
OFF Voltage Level	< 2.0 VAC/VDC		
Maximum OFF Current	1.5 mA		
Status Indicators	Logic Side, Green		
Input Details			
Input Type	High-Speed DC	Standard ¹	
Location	X0...X9	X10...X19	
OFF to ON Response	DC	< 2 μ s	2ms
	AC	–	10ms ²
ON to OFF Response	DC	< 2 μ s	2ms
	AC	–	10ms ²
Maximum Switching Frequency	DC	250kHz	
	AC	~ 30Hz	

- 1. All inputs may be used as standard inputs. Only the first 10 inputs (X0...X9) are capable of high-speed DC operation.*
- 2. 60Hz to 240Hz filter should be set in the software when using an AC line signal.*

BX-DM1E-36ED13-D Wiring, Continued

Discrete Input Connection Options

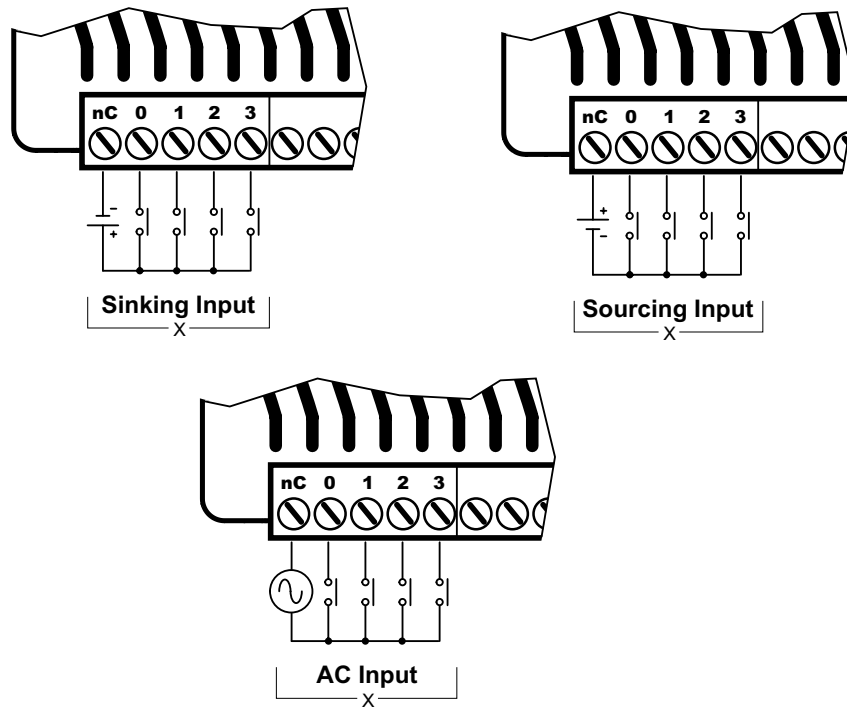

Discrete Input Internal Circuitry *

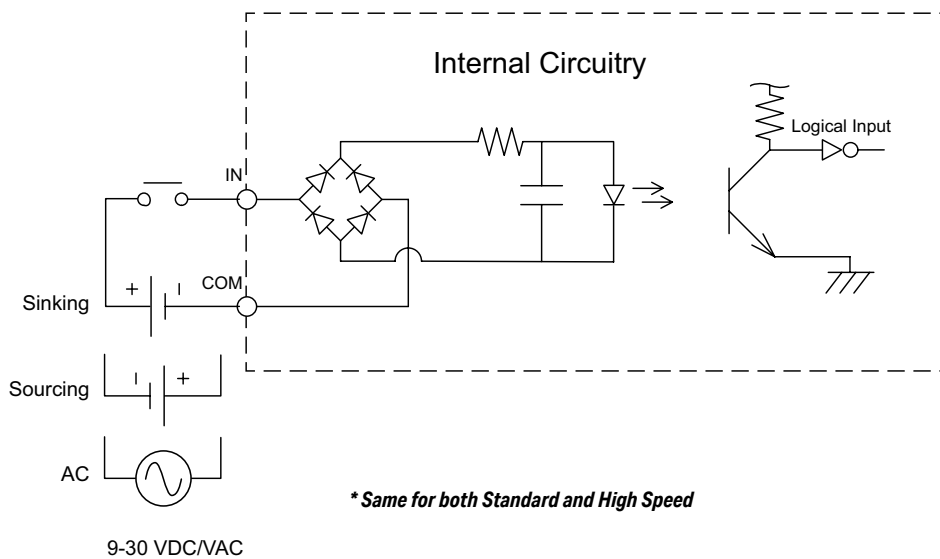

BX-DM1E-36ED13-D Wiring, Continued

Discrete Output Specifications

Discrete Output Specifications		
Output Type	Sinking	
Total Outputs per Module	16	
Commons	4 (4 points/common) Isolated	
Maximum Current per Common	2A	
Nominal Voltage Range	12–24 VDC	
Operating Voltage Range	5–36 VDC	
Maximum Voltage	36VDC	
Minimum Output Current	0.1 mA @ 24VDC	
Maximum Output Current	0.5 A per output No derating over temperature range	
Maximum Inrush Current	5A for 50ms	
Maximum Leakage Current	10 μ A	
ON Voltage Drop	0.05 VDC	
Status Indicators	Logic Side, Green	
Output Details		
Output Type	High-Speed	Standard ¹
Location	Y0...Y7	Y8...Y15
OFF to ON Response	< 2 μ s	< 5ms
ON to OFF Response	< 2 μ s	< 2ms
Maximum Switching Frequency	1m cable - 250kHz 10m cable - 100kHz	~100Hz
Overcurrent, Short Circuit Protection and Short to Ground	Current limit by Common Group, self-resetting	N/A
Overcurrent Trip Level ²	Between 4A and 8A	N/A
Fuse Type	User-supplied external fuse	

- 1. All outputs may be used as standard outputs. Only the first 8 outputs (Y0...Y7) are capable of high-speed DC operation.*
- 2. When the high-speed outputs are in an overcurrent situation, the Common terminal Red LED is on. The output LEDs will remain operational even though the output circuitry is turned off and no power is flowing. This condition is not reported to the CPU.*

BX-DM1E-36ED13-D Wiring, Continued

Discrete Output Connection Options

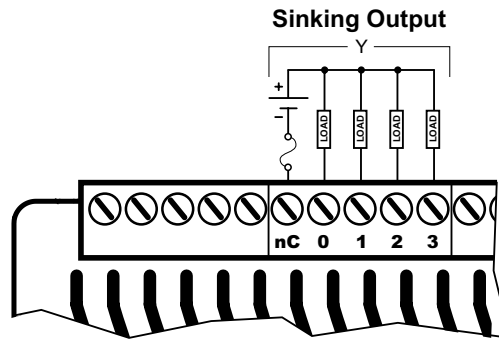

Discrete Standard Output Internal Circuitry

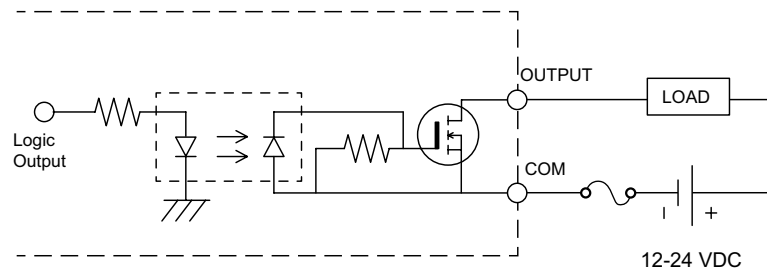

Discrete High-Speed Output Internal Circuitry

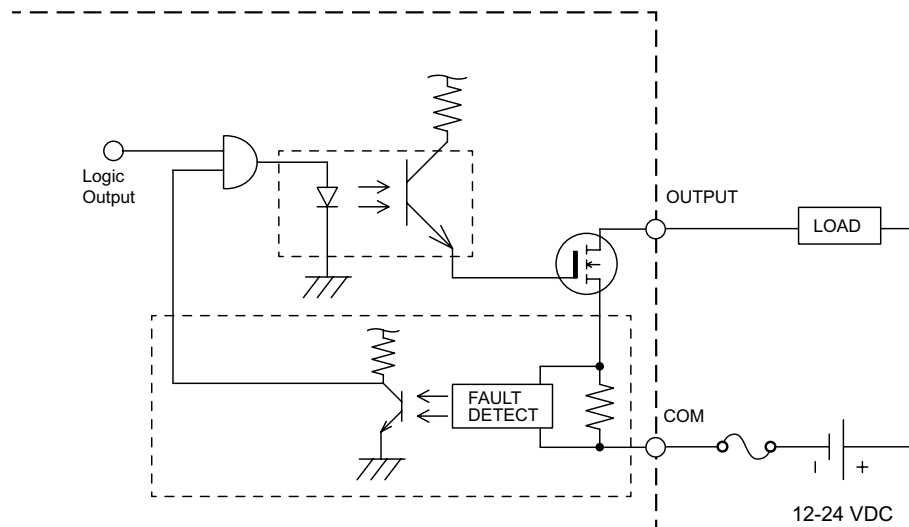

NOTE: When the high speed outputs are in an overcurrent situation, the Common terminal Red LED is on. The output LEDs will remain operational even though the output circuitry is turned off and no power is flowing. This condition is not reported to the CPU.

BX-DM1E-36ED13-D Wiring, Continued

Analog Input Specifications

Analog Input Specifications	
Inputs per Module	4
Commons	1
Input Voltage Range *	Software Selectable $\pm 10V$, $\pm 5V$, $0-10 V$, $0-5 V$
Input Current Range *	Software Selectable $\pm 20mA$, $4-20 mA$
Resolution $\pm 10V$, $\pm 20mA$ $\pm 5V$ $0-5 V$ $4-20 mA$ $0-10 V$	16 bits (0–65535 counts) 15 bits (0–32767 counts) 14 bits (0–16383 counts) ~15 bits (6553–32767 counts) 15 bits (0–32767 counts)
Input Impedance Voltage Modes	100k Ω
Absolute Maximum Input, Voltage Mode	$\pm 30V$
Input Impedance Current Modes	249 Ω
Absolute Maximum Input, Current Mode	$\pm 40mA$ sustained, $\pm 100mA$ for < 5s
Conversion Time	1.2 ms
Input Stability	0.02% of Full Hardware Range = 13 Counts
Full Scale Calibration Error	0.05% of Full Hardware Range = 33 Counts
Offset Calibration Error	0.01% of Full Hardware Range = 7 Counts
Accuracy vs Temperature Error	0.05% of Full Hardware Range = 33 Counts
Maximum Linearity Error (End to End)	0.1% of Full Hardware Range = 66 Counts
Maximum Inaccuracy	0.2% of Full Hardware Range = 131 Counts
Fuse Type	User-supplied external fuse

* Software selectable per channel

BX-DM1E-36ED13-D Wiring, Continued

Analog Input Connection Options

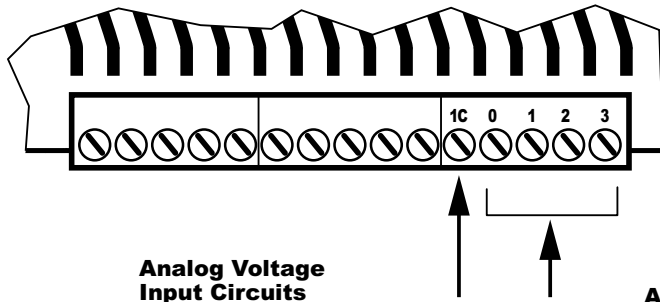

Analog Voltage Input Circuits

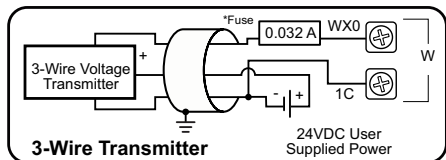
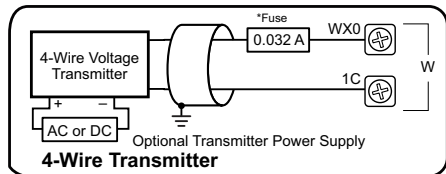

NOTE: Shield should be connected only at one end, to ground at the source device.

Analog Current Sinking Input Circuits

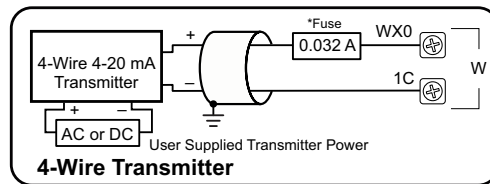
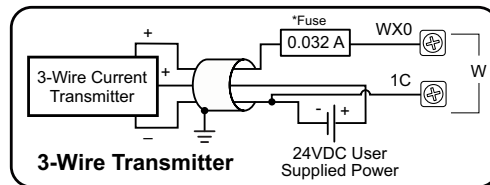
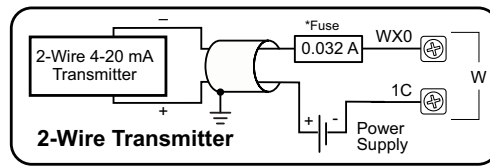

NOTE: Shield should be connected only at one end, to ground at the source device.



NOTE: An Edison S500-32-R 0.032A fast-acting fuse is recommended for all analog voltage inputs, analog outputs, and current loops.

BX-DM1E-36ED13-D Wiring, Continued

Analog Output Specifications

Analog Output Specifications	
Outputs per Module	2
Commons	3
Output Voltage Range *	Software Selectable $\pm 10V$, $\pm 5V$, 0–10 V, 0–5 V
Output Current Range *	Software Selectable $\pm 20mA$, 4–20 mA
Resolution $\pm 10V$, $\pm 20mA$ $\pm 5V$ 0–5 V 4–20 mA 0–10 V	16 bits (0–65535 counts) 15 bits (0–32767 counts) 14 bits (0–16383 counts) ~15 bits (6553–32767 counts) 15 bits (0–32767 counts)
Minimum Voltage Load Impedance	1k Ω
Maximum Current Load Impedance	500 Ω
Maximum Rating	Continuous Short Circuit Protected
Settling Time	< 1ms
Output Stability	0.02% of Full Hardware Range = 13 Counts
Full Scale Calibration Error	0.05% of Full Hardware Range = 33 Counts
Offset Calibration Error	0.01% of Full Hardware Range = 7 Counts
Accuracy vs Temperature Error	0.05% of Full Hardware Range = 33 Counts
Maximum Linearity Error (End to End)	0.1% of Full Hardware Range = 66 Counts
Maximum Inaccuracy	0.2% of Full Hardware Range = 131 Counts
Fuse Type	User-supplied external fuse

* Software selectable per channel

Analog Output Connection Options

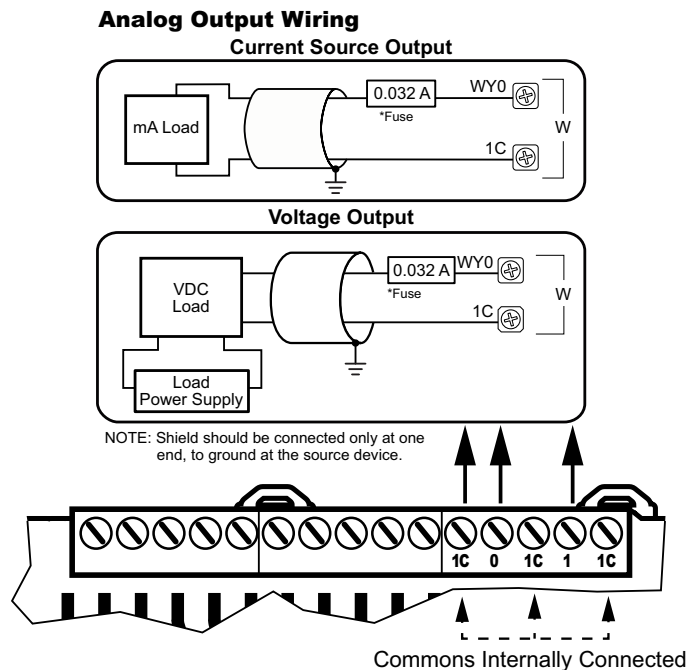

NOTE: An Edison S500-32-R 0.032A fast-acting fuse is recommended for all analog voltage inputs, analog outputs, and current loops.

BX-DM1E-36ED23 Wiring

This MPU is made up of 36 discrete I/O points. The connections are grouped as follows:

- 20 discrete inputs - sinking/sourcing; rated for 12–24 VAC/VDC. They are located along the bottom of the unit; configured in five (5) groups of 5 terminals, each comprised of 4 inputs and an isolated common.
- 16 discrete outputs - sourcing; rated at 12–24 VDC. They are located along the top of the unit starting to the right of the 24VDC auxiliary output terminals. The outputs are configured in four (4) groups of 5 terminals, each comprised of 4 outputs and an isolated common.
- 4 analog inputs and 2 analog outputs. The analog inputs are located along the bottom of the unit to the right of the discrete inputs. The analog inputs are grouped together on 5 terminals consisting of 4 input and a shared analog input common. The analog outputs are located along the top of the unit to the right of the discrete outputs. The analog outputs are grouped together on 5 terminals consisting of 2 outputs and 3 shared analog output common terminals. The analogs share these common features:
 - current or voltage selectable through software,
 - 16-bit resolution @ $\pm 20\text{mA}$, $\pm 10\text{VDC}$
 - current signal ranges of 4–20 mA, $\pm 20\text{mA}$,
 - voltage signal ranges of 0–5 VDC, 0–10 VDC, $\pm 5\text{VDC}$, $\pm 10\text{VDC}$.

This MPU requires an external 120–240 VAC power supply. The AC power supply connection and the 24VDC auxiliary output supply terminals are located on the top left side of the unit.

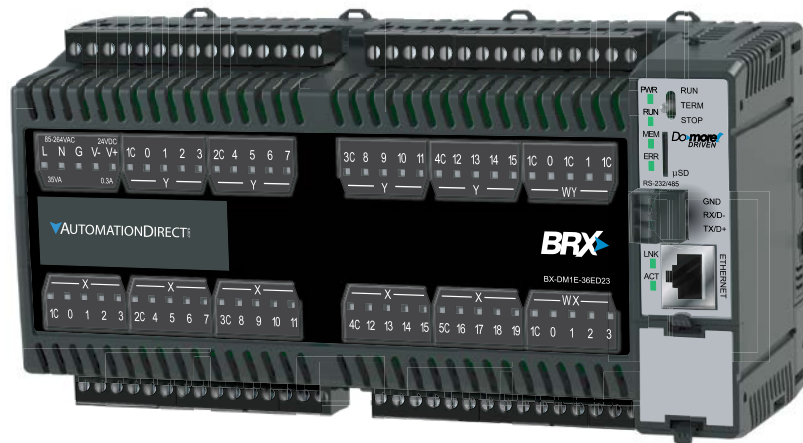

BX-DM1E-36ED23



NOTE: Eight (8) Expansion Modules can be connected to extend I/O capacity.

BX-DM1E-36ED23 Wiring, Continued

Power Supply Specifications

Power Supply Specifications	
Nominal Voltage Range	120–240 VAC
Input Voltage Range (Tolerance)	85–264 VAC
Rated Operating Frequency	47–63 Hz
Maximum Input Power	40VA
Cold Start Inrush Current	1.5 A, 2ms
Maximum Inrush Current (Hot Start)	1.5 A, 2ms
Internal Input Fuse Protection	Micro fuse 250V, 2A Non-replaceable
Acceptable External Power Drop Time	10ms
Under Input Voltage Lock-out	80VAC
Input Transient Protection	Input choke and line filter
Heat Dissipation	24.4 W Max
Isolated User 24VDC Output	24VDC @ 0.3 A max, <1V P-P Ripple, Integrated self-resetting short circuit protection
Voltage Withstand (dielectric)	1500VAC Power Inputs to Ground applied for 1 minute 1500VAC Ground to 24VDC Output applied for 1 minute
Insulation Resistance	>10MΩ @ 500VDC
Software Version Required	Do-more! Designer version 2.0 or later

Power Supply Connections

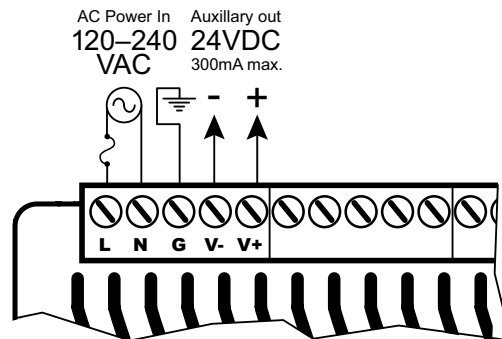

WARNING: Do not exceed the 24VDC auxiliary power supply load limit of 300mA.



WARNING: The BRX System **MUST** have a proper earth ground. Do not operate the BRX MPU without proper earth grounding.

BX-DM1E-36ED23 Wiring, Continued

Discrete Input Specifications

Discrete Input Specifications			
Input Type	Sink/Source		
Total Inputs per Module	20		
Commons	5 (4 points/common) Isolated		
Nominal Voltage Range	12–24 VAC/VDC		
Input Voltage Range	9–30 VAC/VDC		
Maximum Voltage	30 VAC/VDC		
DC Frequency	0–250 kHz - High-speed		
Minimum Pulse Width	0.5 μ s - High-speed		
AC Frequency	47–63 Hz ²		
Input Impedance	3k Ω @ 24VDC		
Input Current (typical)	6mA @ 24 VAC/VDC		
Maximum Input Current	12mA @ 30 VAC/VDC		
ON Voltage Level	> 9.0 VAC/VDC		
OFF Voltage Level	< 2.0 VAC/VDC		
Maximum OFF Current	1.5 mA		
Status Indicators	Logic Side, Green		
Input Details			
Input Type	High-Speed DC		Standard ¹
Location	X0...X9		X10...X19
OFF to ON Response	DC	< 2 μ s	2ms
	AC	–	10ms ²
ON to OFF Response	DC	< 2 μ s	2ms
	AC	–	10ms ²
Maximum Switching Frequency	DC	250kHz	
	AC	~ 30Hz	

- 1. All inputs may be used as standard inputs. Only the first 10 inputs (X0...X9) are capable of high-speed DC operation.*
- 2. 60Hz to 240Hz filter should be set in the software when using an AC line signal.*

BX-DM1E-36ED23 Wiring, Continued

Discrete Input Connection Options

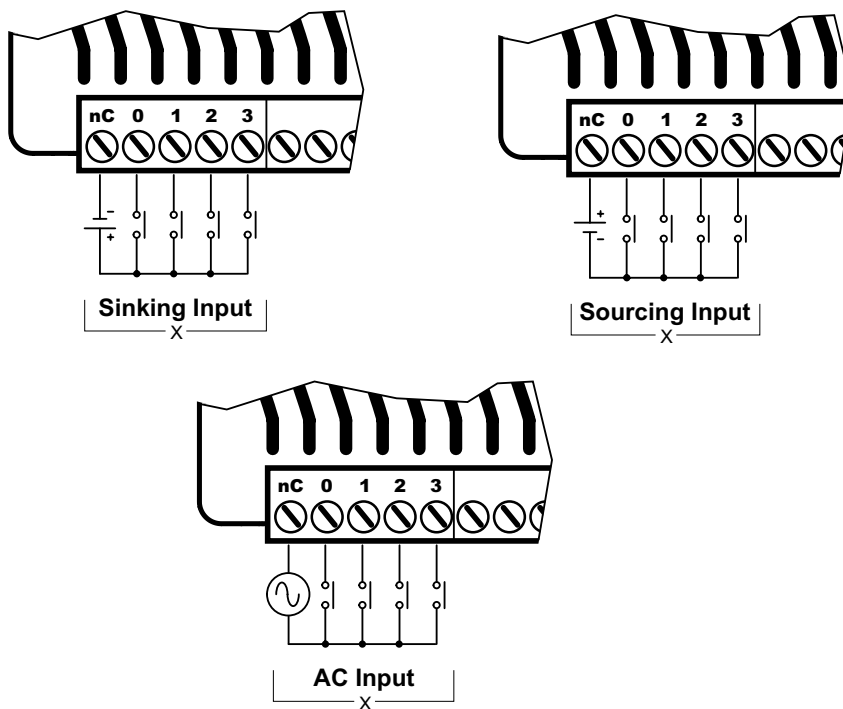

Discrete Input Internal Circuitry *

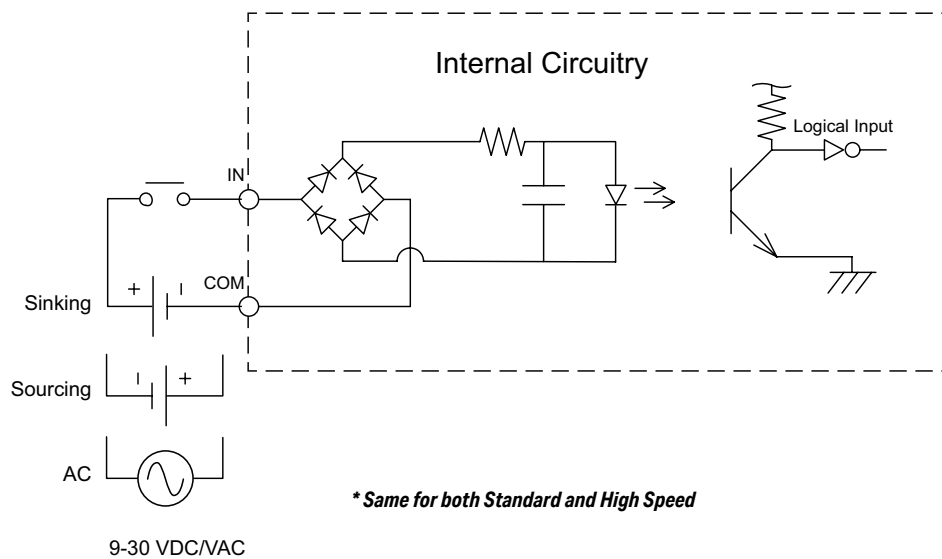

BX-DM1E-36ED23 Wiring, Continued

Discrete Output Specifications

Discrete Output Specifications		
Output Type	Sourcing	
Total Outputs per Module	16	
Commons	4 (4 points/common) Isolated	
Maximum Current per Common	2A	
Nominal Voltage Range	12–24 VDC	
Operating Voltage Range	5–36 VDC	
Maximum Voltage	36VDC	
Minimum Output Current	0.1 mA @ 24VDC	
Maximum Output Current	0.5 A per output No derating over temperature range	
Maximum Inrush Current	5A for 50ms	
Maximum Leakage Current	10 μ A	
ON Voltage Drop	0.05 VDC	
Status Indicators	Logic Side, Green	
Output Details		
Output Type	High-Speed	Standard ¹
Location	Y0...Y7	Y8...Y15
OFF to ON Response	< 2 μ s	< 5ms
ON to OFF Response	< 2 μ s	< 2ms
Maximum Switching Frequency	1m cable - 250kHz 10m cable - 100kHz	~100Hz
Overcurrent, Short Circuit Protection and Short to Ground	Current limit by Common Group, self-resetting	N/A
Overcurrent Trip Level ²	Between 4A and 8A	N/A
Fuse Type	User-supplied external fuse	

- 1. All outputs may be used as standard outputs. Only the first 8 outputs (Y0...Y7) are capable of high-speed DC operation.*
- 2. When the high-speed outputs are in an overcurrent situation, the Common terminal Red LED is on. The output LEDs will remain operational even though the output circuitry is turned off and no power is flowing. This condition is not reported to the CPU.*

BX-DM1E-36ED23 Wiring, Continued

Discrete Output Connection Options

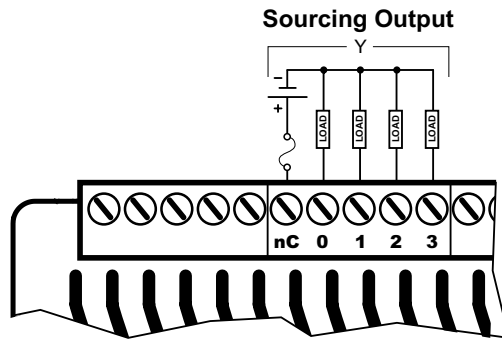

Discrete Standard Output Internal Circuitry

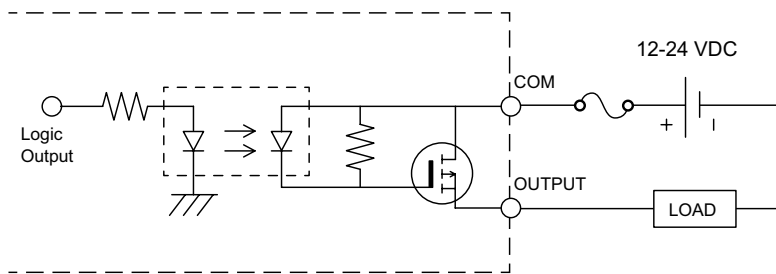

Discrete High-Speed Output Internal Circuitry

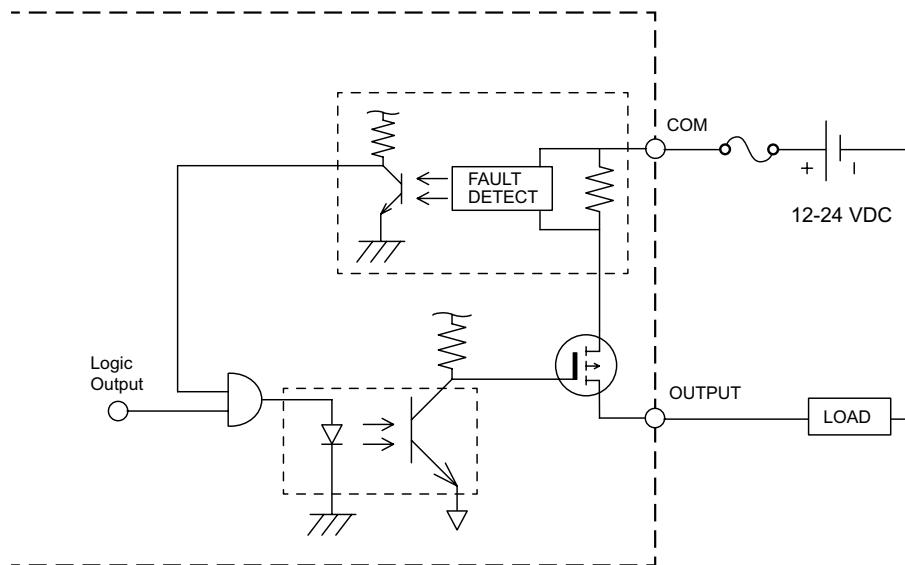

NOTE: When the high speed outputs are in an overcurrent situation, the Common terminal Red LED is on. The output LEDs will remain operational even though the output circuitry is turned off and no power is flowing. This condition is not reported to the CPU.

BX-DM1E-36ED23 Wiring, Continued

Analog Input Specifications

Analog Input Specifications	
Inputs per Module	4
Commons	1
Input Voltage Range *	Software Selectable $\pm 10V$, $\pm 5V$, 0–10 V, 0–5 V
Input Current Range *	Software Selectable $\pm 20mA$, 4–20 mA
Resolution $\pm 10V$, $\pm 20mA$ $\pm 5V$ 0–5 V 4–20 mA 0–10 V	16 bits (0–65535 counts) 15 bits (0–32767 counts) 14 bits (0–16383 counts) ~15 bits (6553–32767 counts) 15 bits (0–32767 counts)
Input Impedance Voltage Modes	100k Ω
Absolute Maximum Input, Voltage Mode	$\pm 30V$
Input Impedance Current Modes	249 Ω
Absolute Maximum Input, Current Mode	$\pm 40mA$ sustained, $\pm 100mA$ for < 5s
Conversion Time	1.2 ms
Input Stability	0.02% of Full Hardware Range = 13 Counts
Full Scale Calibration Error	0.05% of Full Hardware Range = 33 Counts
Offset Calibration Error	0.01% of Full Hardware Range = 7 Counts
Accuracy vs Temperature Error	0.05% of Full Hardware Range = 33 Counts
Maximum Linearity Error (End to End)	0.1% of Full Hardware Range = 66 Counts
Maximum Inaccuracy	0.2% of Full Hardware Range = 131 Counts
Fuse Type	User-supplied external fuse

* *Software selectable per channel*

BX-DM1E-36ED23 Wiring, Continued

Analog Input Connection Options

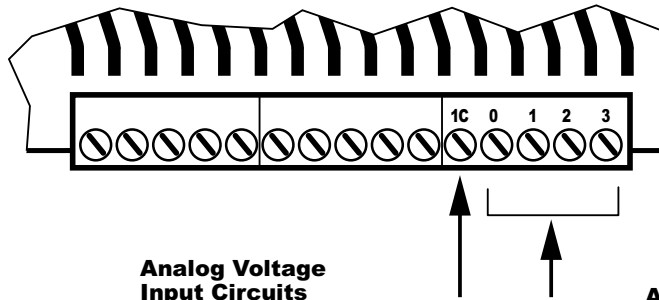

Analog Voltage Input Circuits

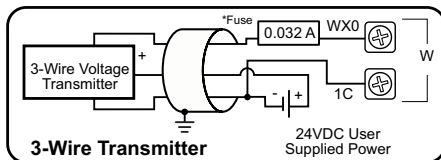
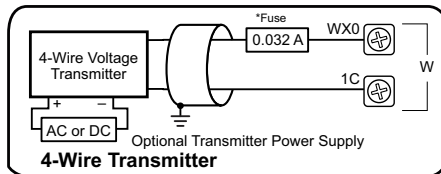

NOTE: Shield should be connected only at one end, to ground at the source device.

Analog Current Sinking Input Circuits

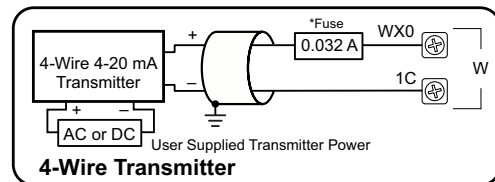
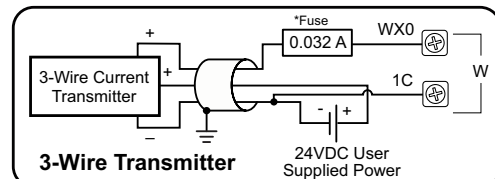
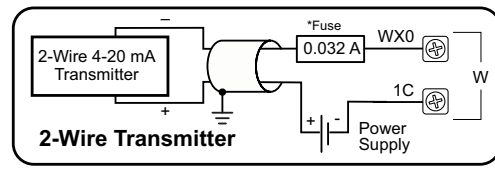

NOTE: Shield should be connected only at one end, to ground at the source device.



NOTE: An Edison S500-32-R 0.032A fast-acting fuse is recommended for all analog voltage inputs, analog outputs, and current loops.

BX-DM1E-36ED23 Wiring, Continued

Analog Output Specifications

Analog Output Specifications	
Outputs per Module	2
Commons	3
Output Voltage Range *	Software Selectable $\pm 10V$, $\pm 5V$, 0–10 V, 0–5 V
Output Current Range *	Software Selectable $\pm 20mA$, 4–20 mA
Resolution $\pm 10V$, $\pm 20mA$ $\pm 5V$ 0–5 V 4–20 mA 0–10 V	16 bits (0–65535 counts) 15 bits (0–32767 counts) 14 bits (0–16383 counts) ~15 bits (6553–32767 counts) 15 bits (0–32767 counts)
Minimum Voltage Load Impedance	1k Ω
Maximum Current Load Impedance	500 Ω
Maximum Rating	Continuous Short Circuit Protected
Settling Time	< 1ms
Output Stability	0.02% of Full Hardware Range = 13 Counts
Full Scale Calibration Error	0.05% of Full Hardware Range = 33 Counts
Offset Calibration Error	0.01% of Full Hardware Range = 7 Counts
Accuracy vs Temperature Error	0.05% of Full Hardware Range = 33 Counts
Maximum Linearity Error (End to End)	0.1% of Full Hardware Range = 66 Counts
Maximum Inaccuracy	0.2% of Full Hardware Range = 131 Counts
Fuse Type	User-supplied external fuse

* Software selectable per channel

Analog Output Connection Options

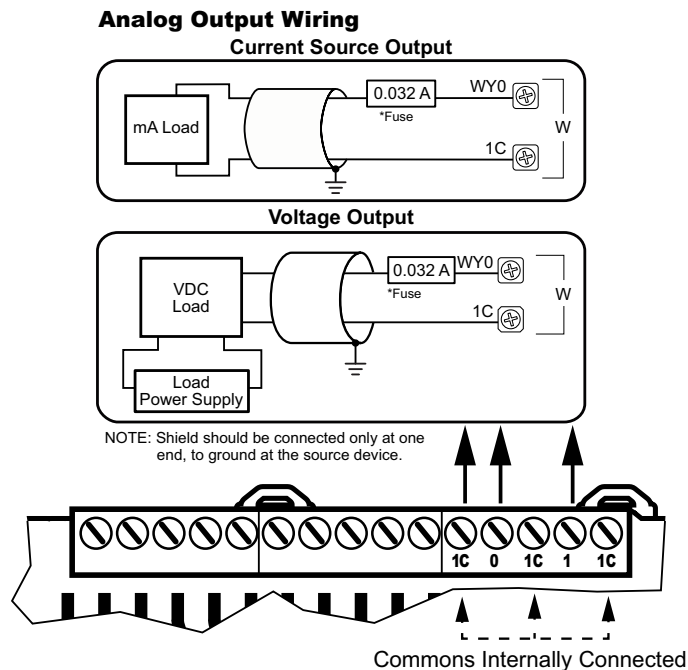

NOTE: An Edison S500-32-R 0.032A fast-acting fuse is recommended for all analog voltage inputs, analog outputs, and current loops.

BX-DM1E-36ED23-D Wiring

This MPU is made up of 36 discrete I/O points. The connections are grouped as follows:

- 20 discrete inputs - sinking/sourcing; rated for 12–24 VAC/VDC. They are located along the bottom of the unit; configured in five (5) groups of 5 terminals, each comprised of 4 inputs and an isolated common.
- 16 discrete outputs - sourcing; rated at 12–24 VDC. They are located along the top of the unit starting to the right of the 24VDC external power supply terminals. The outputs are configured in four (4) groups of 5 terminals, each comprised of 4 outputs and an isolated common.
- 4 analog inputs and 2 analog outputs. The analog inputs are located along the bottom of the unit to the right of the discrete inputs. The analog inputs are grouped together on 5 terminals consisting of 4 input and a shared analog input common. The analog outputs are located along the top of the unit to the right of the discrete outputs. The analog outputs are grouped together on 5 terminals consisting of 2 outputs and 3 shared analog output common terminals. The analog share these common features:
 - current or voltage selectable through software,
 - 16-bit resolution @ $\pm 20\text{mA}$, $\pm 10\text{VDC}$
 - current signal ranges of 4–20 mA, $\pm 20\text{mA}$,
 - voltage signal ranges of 0–5 VDC, 0–10 VDC, $\pm 5\text{VDC}$, $\pm 10\text{VDC}$.

This MPU requires an external 12–24 VDC power supply. The DC power supply connection is located on the top left side of the unit. There is no 24VDC auxiliary output supply.

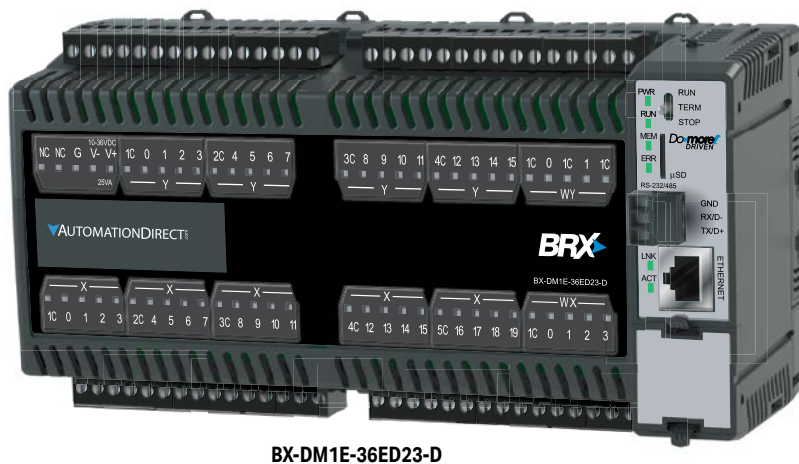

BX-DM1E-36ED23-D



NOTE: Eight (8) Expansion Modules can be connected to extend I/O capacity.

BX-DM1E-36ED23-D, Continued

Power Supply Specifications

Power Supply Specifications	
Nominal Voltage Range*	12–24 VDC
Input Voltage Range (Tolerance)*	10–36 VDC
Maximum Input Voltage Ripple	< ±10%
Maximum Input Power	30W
Cold Start Inrush Current	5A, 2ms
Maximum Inrush Current (Hot Start)	5A, 2ms
Internal Input Protection	Reverse polarity protection and undervoltage lockout via transistor circuit
Acceptable External Power Drop Time	10ms
Under Input Voltage Lock-out	<9VDC
Heat Dissipation	22.1 W Max
Isolated User 24VDC Output	None
Voltage Withstand (dielectric)	1500VAC power Inputs to ground applied for 1 minute
Insulation Resistance	>10MΩ @ 500VDC
Software Version Required	Do-more! Designer version 2.0 or later

* Class 2 or LPS Power Supply required.

Power Supply Connections

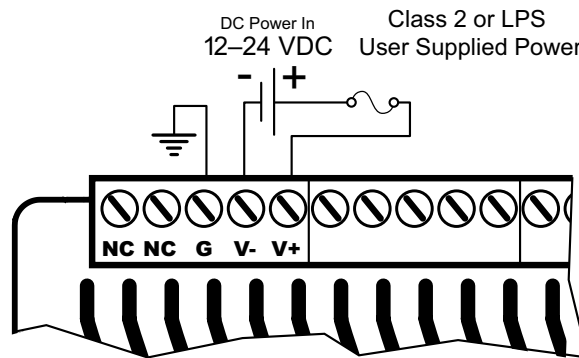

WARNING: No External AC power supply needed on this unit. The two terminals marked "NC" are not used. These terminals are not internally connected. **DO NOT CONNECT ANYTHING TO THESE TERMINALS!**



WARNING: The BRX System **MUST** have a proper earth ground. Do not operate the BRX MPU without proper earth grounding.

BX-DM1E-36ED23-D Wiring, Continued

Discrete Input Specifications

Discrete Input Specifications			
Input Type	Sink/Source		
Total Inputs per Module	20		
Commons	5 (4 points/common) Isolated		
Nominal Voltage Range	12–24 VAC/VDC		
Input Voltage Range	9–30 VAC/VDC		
Maximum Voltage	30 VAC/VDC		
DC Frequency	0–250 kHz - High-speed		
Minimum Pulse Width	0.5 μ s - High-speed		
AC Frequency	47–63 Hz ²		
Input Impedance	3k Ω @ 24VDC		
Input Current (typical)	6mA @ 24 VAC/VDC		
Maximum Input Current	12mA @ 30 VAC/VDC		
ON Voltage Level	> 9.0 VAC/VDC		
OFF Voltage Level	< 2.0 VAC/VDC		
Maximum OFF Current	1.5 mA		
Status Indicators	Logic Side, Green		
Input Details			
Input Type	High-Speed DC		Standard ¹
Location	X0...X9		X10...X19
OFF to ON Response	DC	< 2 μ s	2ms
	AC	–	10ms ²
ON to OFF Response	DC	< 2 μ s	2ms
	AC	–	10ms ²
Maximum Switching Frequency	DC	250kHz	
	AC	~ 30Hz	

- 1. All inputs may be used as standard inputs. Only the first 10 inputs (X0...X9) are capable of high-speed DC operation.*
- 2. 60Hz to 240Hz filter should be set in the software when using an AC line signal.*

BX-DM1E-36ED23-D Wiring, Continued

Discrete Input Connection Options

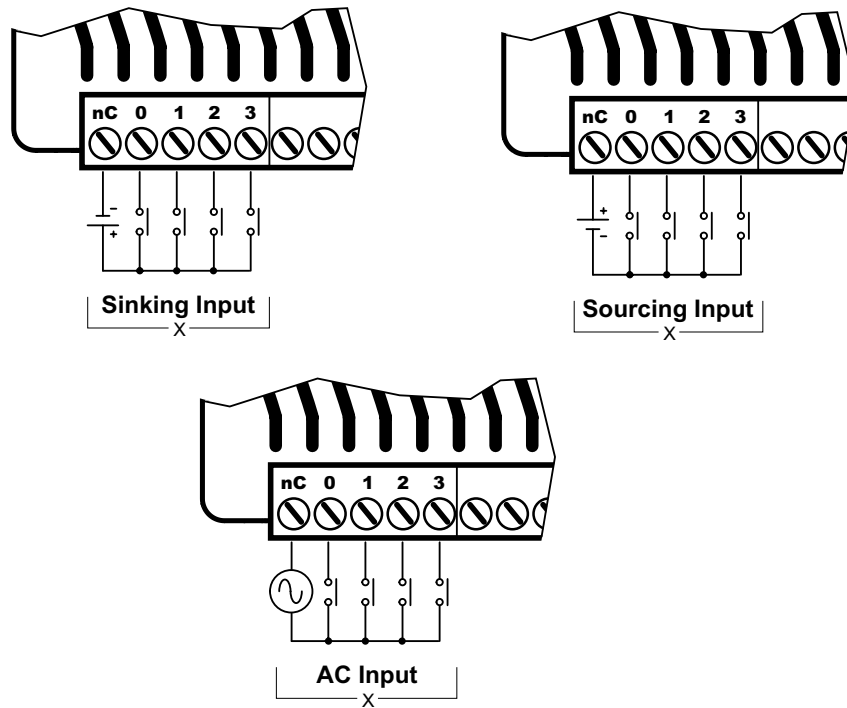

Discrete Input Internal Circuitry *

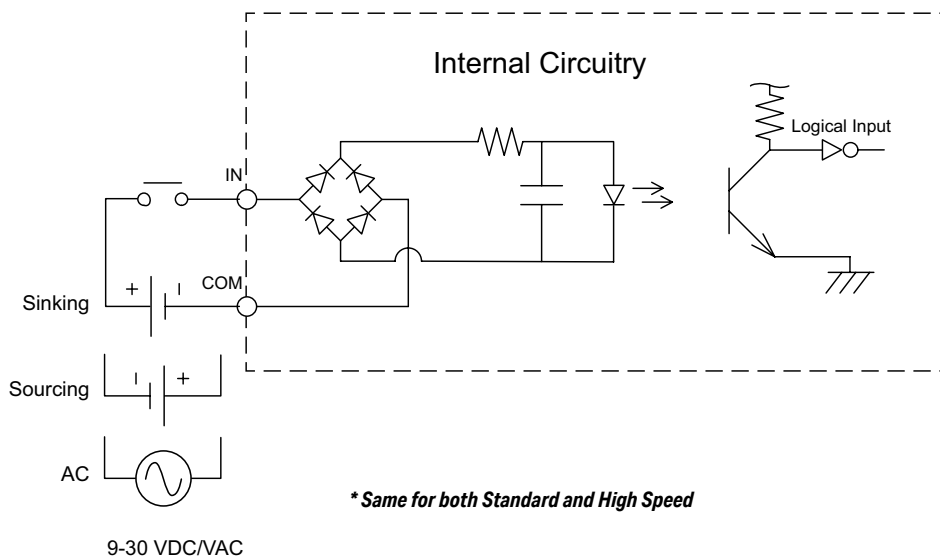

BX-DM1E-36ED23-D Wiring, Continued

Discrete Output Specifications

Discrete Output Specifications		
Output Type	Sourcing	
Total Outputs per Module	16	
Commons	4 (4 points/common) Isolated	
Maximum Current per Common	2A	
Nominal Voltage Range	12–24 VDC	
Operating Voltage Range	5–36 VDC	
Maximum Voltage	36VDC	
Minimum Output Current	0.1 mA @ 24VDC	
Maximum Output Current	0.5 A per output No derating over temperature range	
Maximum Inrush Current	5A for 50ms	
Maximum Leakage Current	10 μ A	
ON Voltage Drop	0.05 VDC	
Status Indicators	Logic Side, Green	
Output Details		
Output Type	High-Speed	Standard ¹
Location	Y0...Y7	Y8...Y15
OFF to ON Response	< 2 μ s	< 5ms
ON to OFF Response	< 2 μ s	< 2ms
Maximum Switching Frequency	1m cable - 250kHz 10m cable - 100kHz	~100Hz
Overcurrent, Short Circuit Protection and Short to Ground	Current limit by Common Group, self-resetting	N/A
Overcurrent Trip Level ²	Between 4A and 8A	N/A
Fuse Type	User-supplied external fuse	

- 1. All outputs may be used as standard outputs. Only the first 8 outputs (Y0...Y7) are capable of high-speed DC operation.*
- 2. When the high-speed outputs are in an overcurrent situation, the Common terminal Red LED is on. The output LEDs will remain operational even though the output circuitry is turned off and no power is flowing. This condition is not reported to the CPU.*

BX-DM1E-36ED23-D Wiring, Continued

Discrete Output Connection Options

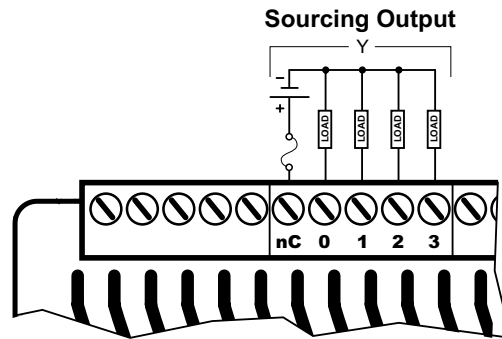

Discrete Standard Output Internal Circuitry

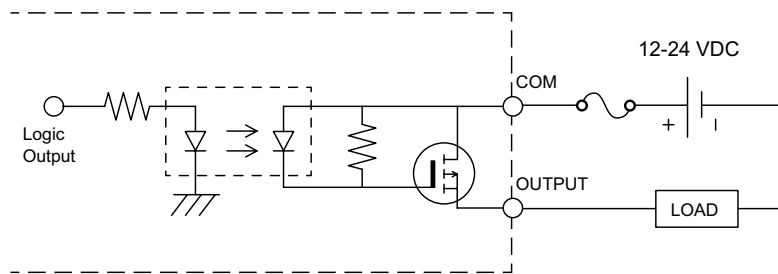

Discrete High-Speed Output Internal Circuitry

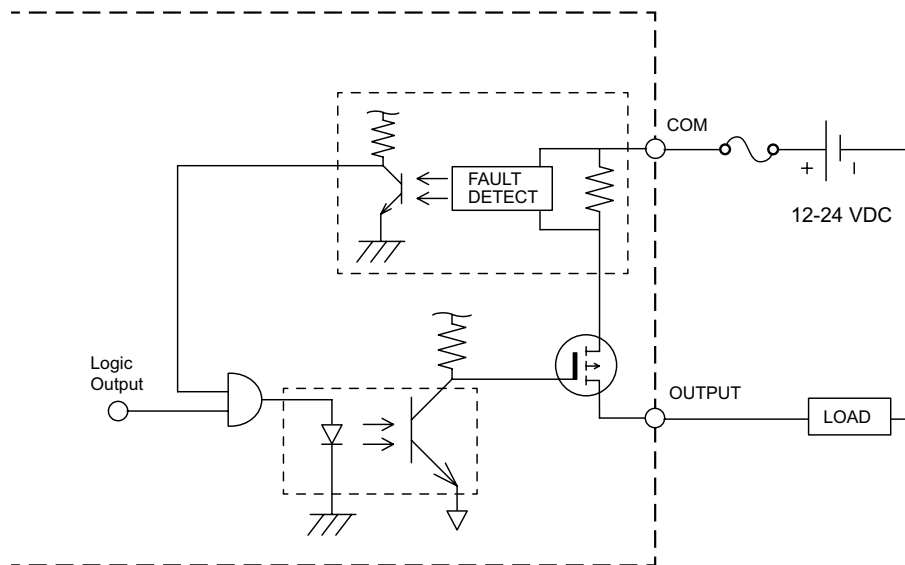

NOTE: When the high speed outputs are in an overcurrent situation, the Common terminal Red LED is on. The output LEDs will remain operational even though the output circuitry is turned off and no power is flowing. This condition is not reported to the CPU.

BX-DM1E-36ED23-D Wiring, Continued

Analog Input Specifications

Analog Input Specifications	
Inputs per Module	4
Commons	1
Input Voltage Range *	Software Selectable $\pm 10V$, $\pm 5V$, 0–10 V, 0–5 V
Input Current Range *	Software Selectable $\pm 20mA$, 4–20 mA
Resolution $\pm 10V$, $\pm 20mA$ $\pm 5V$ 0–5 V 4–20 mA 0–10 V	16 bits (0–65535 counts) 15 bits (0–32767 counts) 14 bits (0–16383 counts) ~15 bits (6553–32767 counts) 15 bits (0–32767 counts)
Input Impedance Voltage Modes	100k Ω
Absolute Maximum Input, Voltage Mode	$\pm 30V$
Input Impedance Current Modes	249 Ω
Absolute Maximum Input, Current Mode	$\pm 40mA$ sustained, $\pm 100mA$ for < 5s
Conversion Time	1.2 ms
Input Stability	0.02% of Full Hardware Range = 13 Counts
Full Scale Calibration Error	0.05% of Full Hardware Range = 33 Counts
Offset Calibration Error	0.01% of Full Hardware Range = 7 Counts
Accuracy vs Temperature Error	0.05% of Full Hardware Range = 33 Counts
Maximum Linearity Error (End to End)	0.1% of Full Hardware Range = 66 Counts
Maximum Inaccuracy	0.2% of Full Hardware Range = 131 Counts
Fuse Type	User-supplied external fuse

* *Software selectable per channel*

BX-DM1E-36ED23-D Wiring, Continued

Analog Input Connection Options

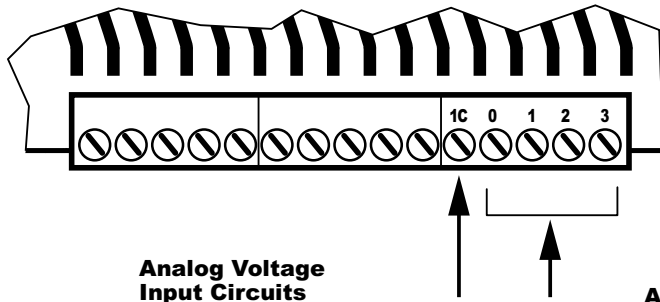

Analog Voltage Input Circuits

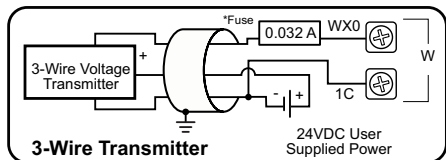
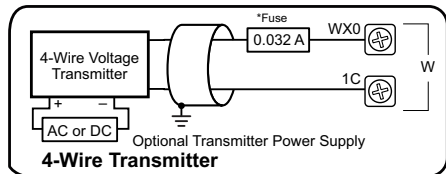

NOTE: Shield should be connected only at one end, to ground at the source device.

Analog Current Sinking Input Circuits

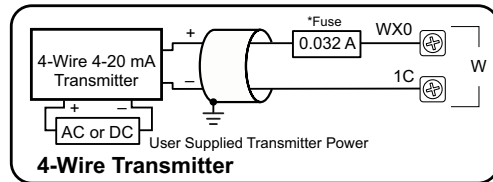
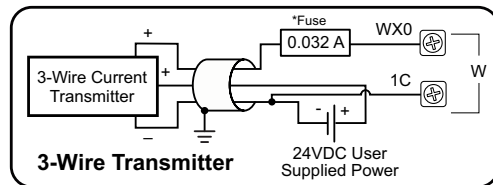
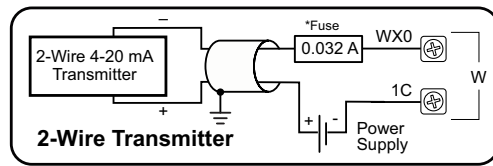

NOTE: Shield should be connected only at one end, to ground at the source device.



NOTE: An Edison S500-32-R 0.032A fast-acting fuse is recommended for all analog voltage inputs, analog outputs, and current loops.

BX-DM1E-36ED23-D Wiring, Continued

Analog Output Specifications

Analog Output Specifications	
Outputs per Module	2
Commons	3
Output Voltage Range *	Software Selectable $\pm 10V$, $\pm 5V$, $0-10 V$, $0-5 V$
Output Current Range *	Software Selectable $\pm 20mA$, $4-20 mA$
Resolution $\pm 10V$, $\pm 20mA$ $\pm 5V$ $0-5 V$ $4-20 mA$ $0-10 V$	16 bits (0-65535 counts) 15 bits (0-32767 counts) 14 bits (0-16383 counts) ~15 bits (6553-32767 counts) 15 bits (0-32767 counts)
Minimum Voltage Load Impedance	1k Ω
Maximum Current Load Impedance	500 Ω
Maximum Rating	Continuous Short Circuit Protected
Settling Time	< 1ms
Output Stability	0.02% of Full Hardware Range = 13 Counts
Full Scale Calibration Error	0.05% of Full Hardware Range = 33 Counts
Offset Calibration Error	0.01% of Full Hardware Range = 7 Counts
Accuracy vs Temperature Error	0.05% of Full Hardware Range = 33 Counts
Maximum Linearity Error (End to End)	0.1% of Full Hardware Range = 66 Counts
Maximum Inaccuracy	0.2% of Full Hardware Range = 131 Counts
Fuse Type	User-supplied external fuse

* Software selectable per channel

Analog Output Connection Options

Analog Output Wiring

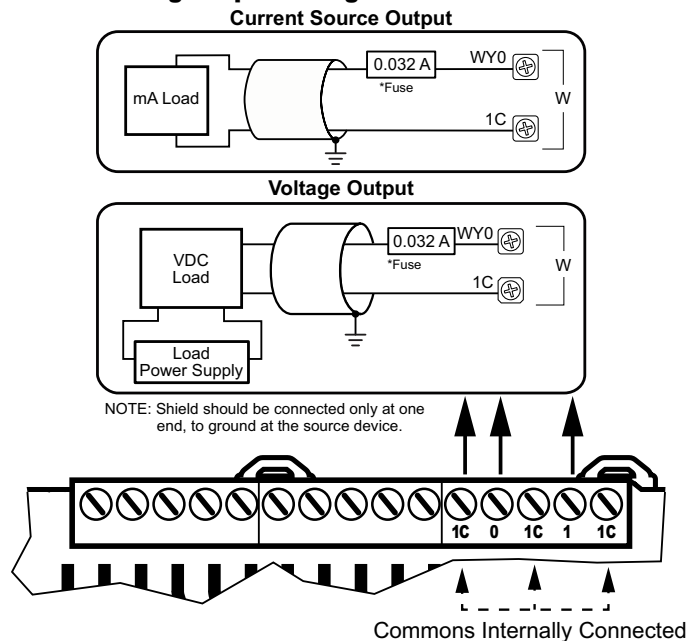

NOTE: An Edison S500-32-R 0.032A fast-acting fuse is recommended for all analog voltage inputs, analog outputs, and current loops.

BX-DM1E-36ER3 Wiring

This MPU is made up of 36 discrete I/O points. The connections are grouped as follows:

- 20 discrete inputs - sinking/sourcing; rated for 12–24 VAC/VDC. They are located along the bottom of the unit; configured in five (5) groups of 5 terminals, each comprised of 4 inputs and an isolated common.
- 16 discrete outputs - Form A Relay (SPST); rated 12–48 VDC/ 24–240 VAC. They are located along the top of the unit starting to the right of the 24VDC auxiliary output terminals. The outputs are configured in four (4) groups of 5 terminals, each comprised of 4 outputs and an isolated common.
- 4 analog inputs and 2 analog outputs. The analog inputs are located along the bottom of the unit to the right of the discrete inputs. The analog inputs are grouped together on 5 terminals consisting of 4 input and a shared analog input common. The analog outputs are located along the top of the unit to the right of the discrete outputs. The analog outputs are grouped together on 5 terminals consisting of 2 outputs and 3 shared analog output common terminals. The analogs share these common features:
 - current or voltage selectable through software,
 - 16-bit resolution @ $\pm 20\text{mA}$, $\pm 10\text{VDC}$
 - current signal ranges of 4–20 mA, $\pm 20\text{mA}$,
 - voltage signal ranges of 0–5 VDC, 0–10 VDC, ± 5 VDC, $\pm 10\text{VDC}$.

This MPU requires an external 120–240 VAC power supply. The AC power supply connection and the 24VDC auxiliary output supply terminals are located on the top left side of the unit.

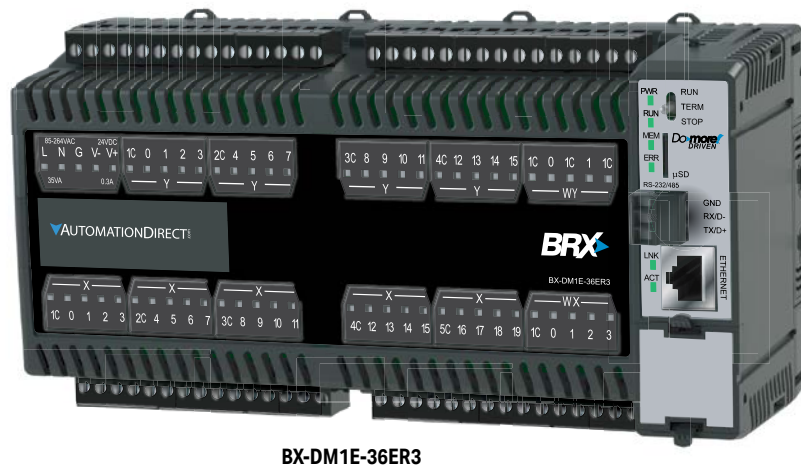

BX-DM1E-36ER3



NOTE: Eight (8) Expansion Modules can be connected to extend I/O capacity.

BX-DM1E-36ER3 Wiring, Continued

Power Supply Specifications

Power Supply Specifications	
Nominal Voltage Range	120–240 VAC
Input Voltage Range (Tolerance)	85–264 VAC
Rated Operating Frequency	47–63 Hz
Maximum Input Power	40VA
Cold Start Inrush Current	1.5 A, 2ms
Maximum Inrush Current (Hot Start)	1.5 A, 2ms
Internal Input Fuse Protection	Micro fuse 250V, 2A Non-replaceable
Acceptable External Power Drop Time	10ms
Under Input Voltage Lock-out	80VAC
Input Transient Protection	Input choke and line filter
Heat Dissipation	27.6 W Max
Isolated User 24VDC Output	24VDC @ 0.3 A max, <1V P-P Ripple, Integrated self-resetting short circuit protection
Voltage Withstand (dielectric)	1500VAC Power Inputs to Ground applied for 1 minute 1500VAC Ground to 24VDC Output applied for 1 minute
Insulation Resistance	>10MΩ @ 500VDC
Software Version Required	Do-more! Designer version 2.0 or later

Power Supply Connections

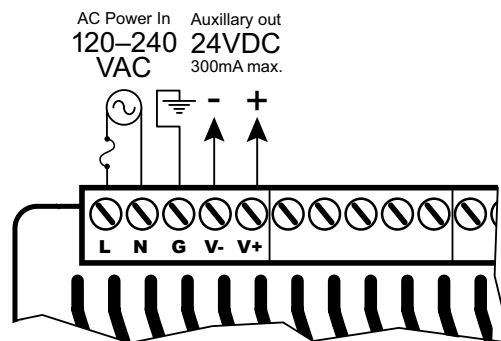

WARNING: Do not exceed the 24VDC auxiliary power supply load limit of 300mA.



WARNING: The BRX System **MUST** have a proper earth ground. Do not operate the BRX MPU without proper earth grounding.

BX-DM1E-36ER3 Wiring, Continued

Discrete Input Specifications

Discrete Input Specifications			
Input Type	Sink/Source		
Total Inputs per Module	20		
Commons	5 (4 points/common) Isolated		
Nominal Voltage Range	12–24 VAC/VDC		
Input Voltage Range	9–30 VAC/VDC		
Maximum Voltage	30 VAC/VDC		
DC Frequency	0–250 kHz - High-speed		
Minimum Pulse Width	0.5 μ s - High-speed		
AC Frequency	47–63 Hz ²		
Input Impedance	3k Ω @ 24VDC		
Input Current (typical)	6mA @ 24 VAC/VDC		
Maximum Input Current	12mA @ 30 VAC/VDC		
ON Voltage Level	> 9.0 VAC/VDC		
OFF Voltage Level	< 2.0 VAC/VDC		
Maximum OFF Current	1.5 mA		
Status Indicators	Logic Side, Green		
Input Details			
Input Type	High-Speed DC		Standard ¹
Location	X0...X9		X10...X19
OFF to ON Response	DC	< 2 μ s	2ms
	AC	–	10ms ²
ON to OFF Response	DC	< 2 μ s	2ms
	AC	–	10ms ²
Maximum Switching Frequency	DC	250kHz	
	AC	~ 30Hz	

1. All inputs may be used as standard inputs. Only the first 10 inputs (X0...X9) are capable of high-speed DC operation.

2. 60Hz to 240Hz filter should be set in the software when using an AC line signal.

BX-DM1E-36ER3 Wiring, Continued

Discrete Input Connection Options

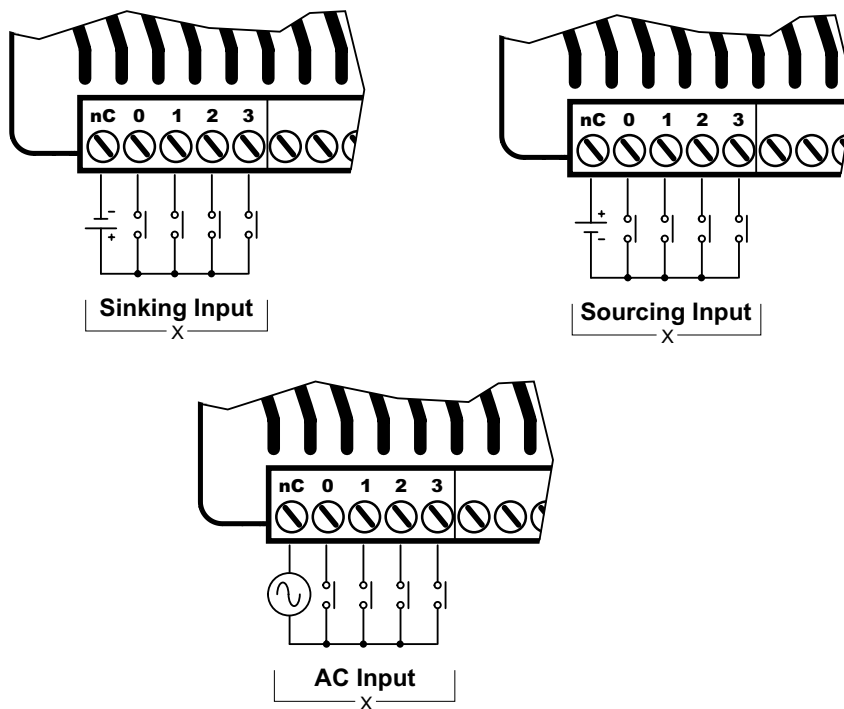

Discrete Input Internal Circuitry *

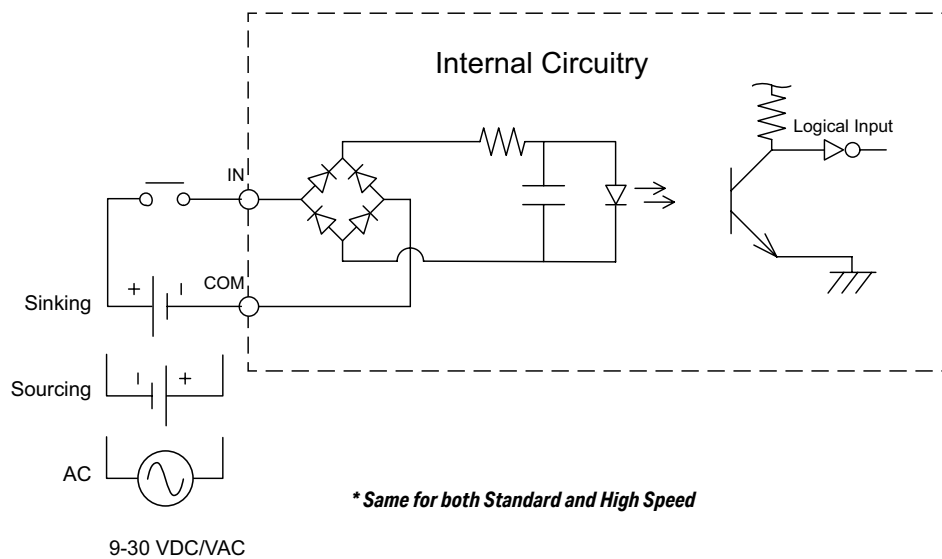

BX-DM1E-36ER3 Wiring, Continued

Discrete Output Specifications

Discrete Output Specifications	
Output Type	Relay Form A (SPST)
Total Outputs per Module	16
Commons	4 (4 points/common) Isolated
Maximum Current per Common	8A
Nominal Voltage Range	12–48 VDC 24–240 VAC
Operating Voltage Range	5–60 VDC 5–264 VAC
Maximum Voltage	60VDC 264VAC
Minimum Output Current	0.1 mA @ 24VDC 0.1 mA @ 24VAC
Maximum Output Current	2A
Maximum Inrush Current	5A for 50ms
Maximum Leakage Current	1 μ A (DC), 300 μ A (AC) due to RC snubber circuit
ON Voltage Drop	0.2 V Max
Status Indicators	Logic Side, Green
Output Details	
Output Type	Standard
Location	Y0...Y15
ON-OFF Response	<10ms
OFF-ON Response	<10ms
Maximum Switching Frequency	10Hz
Relay Cycle Life	5 million operations
Mechanical Endurance	120,000 operations
Electrical Endurance	
Fuse Type	User-supplied external fuse

BX-DM1E-36ER3 Wiring, Continued

Discrete Output Connection Options

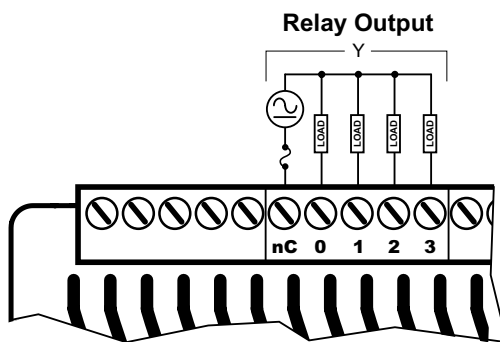

Discrete Standard Output Internal Circuitry

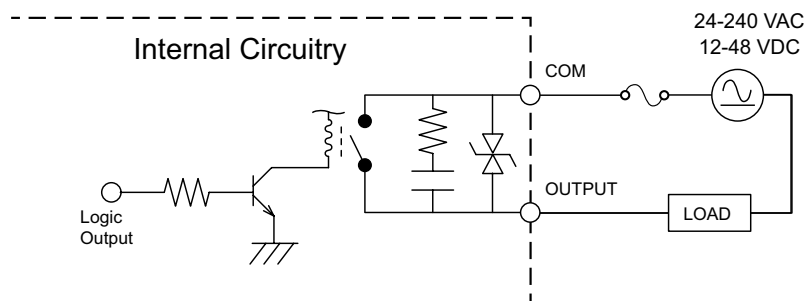

BX-DM1E-36ER3 Wiring, Continued

Analog Input Specifications

Analog Input Specifications	
Inputs per Module	4
Commons	1
Input Voltage Range *	Software Selectable $\pm 10V$, $\pm 5V$, 0–10 V, 0–5 V
Input Current Range *	Software Selectable $\pm 20mA$, 4–20 mA
Resolution $\pm 10V$, $\pm 20mA$ $\pm 5V$ 0–5 V 4–20 mA 0–10 V	16 bits (0–65535 counts) 15 bits (0–32767 counts) 14 bits (0–16383 counts) ~15 bits (6553–32767 counts) 15 bits (0–32767 counts)
Input Impedance Voltage Modes	100k Ω
Absolute Maximum Input, Voltage Mode	$\pm 30V$
Input Impedance Current Modes	249 Ω
Absolute Maximum Input, Current Mode	$\pm 40mA$ sustained, $\pm 100mA$ for < 5s
Conversion Time	1.2 ms
Input Stability	0.02% of Full Hardware Range = 13 Counts
Full Scale Calibration Error	0.05% of Full Hardware Range = 33 Counts
Offset Calibration Error	0.01% of Full Hardware Range = 7 Counts
Accuracy vs Temperature Error	0.05% of Full Hardware Range = 33 Counts
Maximum Linearity Error (End to End)	0.1% of Full Hardware Range = 66 Counts
Maximum Inaccuracy	0.2% of Full Hardware Range = 131 Counts
Fuse Type	User-supplied external fuse

* *Software selectable per channel*

BX-DM1E-36ER3 Wiring, Continued

Analog Input Connection Options

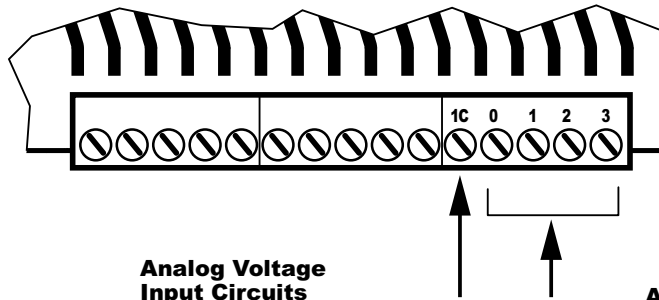

Analog Voltage Input Circuits

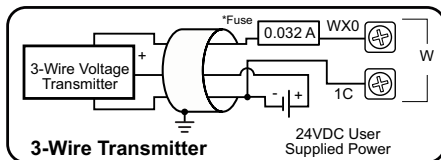
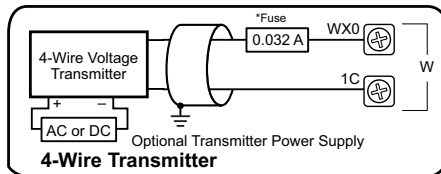

NOTE: Shield should be connected only at one end, to ground at the source device.

Analog Current Sinking Input Circuits

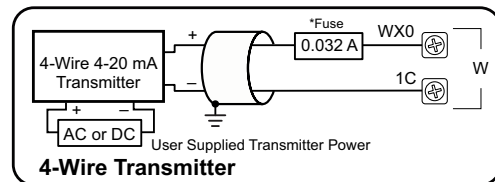
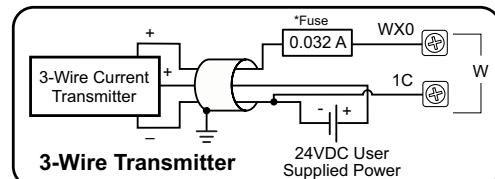
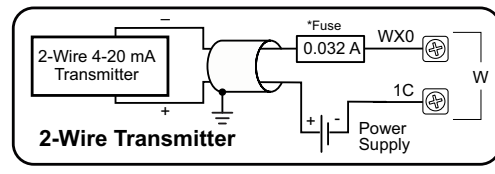

NOTE: Shield should be connected only at one end, to ground at the source device.



NOTE: An Edison S500-32-R 0.032A fast-acting fuse is recommended for all analog voltage inputs, analog outputs, and current loops.

BX-DM1E-36ER3 Wiring, Continued

Analog Output Specifications

Analog Output Specifications	
Outputs per Module	2
Commons	3
Output Voltage Range *	Software Selectable $\pm 10V$, $\pm 5V$, 0–10 V, 0–5 V
Output Current Range *	Software Selectable $\pm 20mA$, 4–20 mA
Resolution $\pm 10V$, $\pm 20mA$ $\pm 5V$ 0–5 V 4–20 mA 0–10 V	16 bits (0–65535 counts) 15 bits (0–32767 counts) 14 bits (0–16383 counts) ~15 bits (6553–32767 counts) 15 bits (0–32767 counts)
Minimum Voltage Load Impedance	1k Ω
Maximum Current Load Impedance	500 Ω
Maximum Rating	Continuous Short Circuit Protected
Settling Time	< 1ms
Output Stability	0.02% of Full Hardware Range = 13 Counts
Full Scale Calibration Error	0.05% of Full Hardware Range = 33 Counts
Offset Calibration Error	0.01% of Full Hardware Range = 7 Counts
Accuracy vs Temperature Error	0.05% of Full Hardware Range = 33 Counts
Maximum Linearity Error (End to End)	0.1% of Full Hardware Range = 66 Counts
Maximum Inaccuracy	0.2% of Full Hardware Range = 131 Counts
Fuse Type	User-supplied external fuse

* Software selectable per channel

Analog Output Connection Options

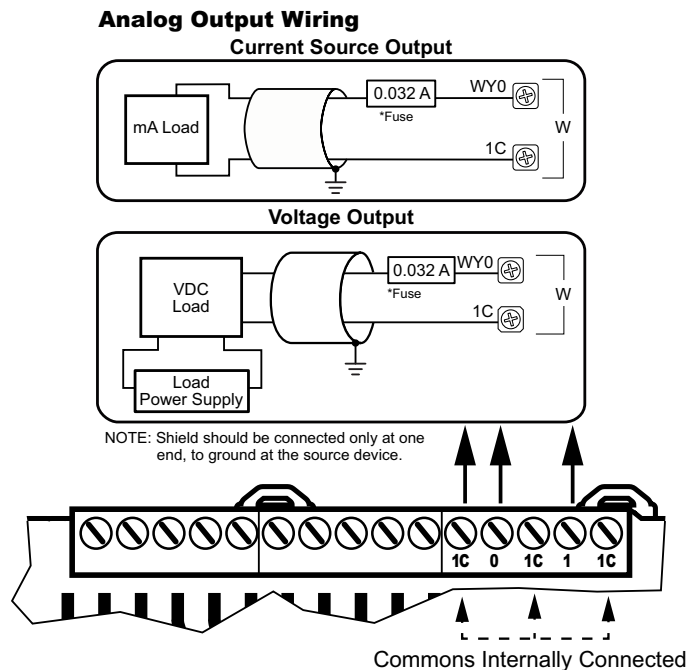

NOTE: An Edison S500-32-R 0.032A fast-acting fuse is recommended for all analog voltage inputs, analog outputs, and current loops.

BX-DM1E-36ER3-D Wiring

This MPU is made up of 36 discrete I/O points. The connections are grouped as follows:

- 20 discrete inputs - sinking/sourcing; rated for 12–24 VAC/VDC. They are located along the bottom of the unit; configured in five (5) groups of 5 terminals, each comprised of 4 inputs and an isolated common.
- 16 discrete outputs - Form A Relay (SPST); rated 12–48 VDC/ 24–240 VAC. They are located along the top of the unit starting to the right of the 24VDC external power supply terminals. The outputs are configured in four (4) groups of 5 terminals, each comprised of 4 outputs and an isolated common.
- 4 analog inputs and 2 analog outputs. The analog inputs are located along the bottom of the unit to the right of the discrete inputs. The analog inputs are grouped together on 5 terminals consisting of 4 input and a shared analog input common. The analog outputs are located along the top of the unit to the right of the discrete outputs. The analog outputs are grouped together on 5 terminals consisting of 2 outputs and 3 shared analog output common terminals. The analogs share these common features:
 - current or voltage selectable through software
 - 16-bit resolution @ $\pm 20\text{mA}$, $\pm 10\text{VDC}$
 - current signal ranges of 4–20 mA, $\pm 20\text{mA}$
 - voltage signal ranges of 0–5 VDC, 0–10 VDC, $\pm 5\text{VDC}$, $\pm 10\text{VDC}$

This MPU requires an external 12–24 VDC power supply. The DC power supply connection is located on the top left side of the unit. There is no 24VDC auxiliary output supply.

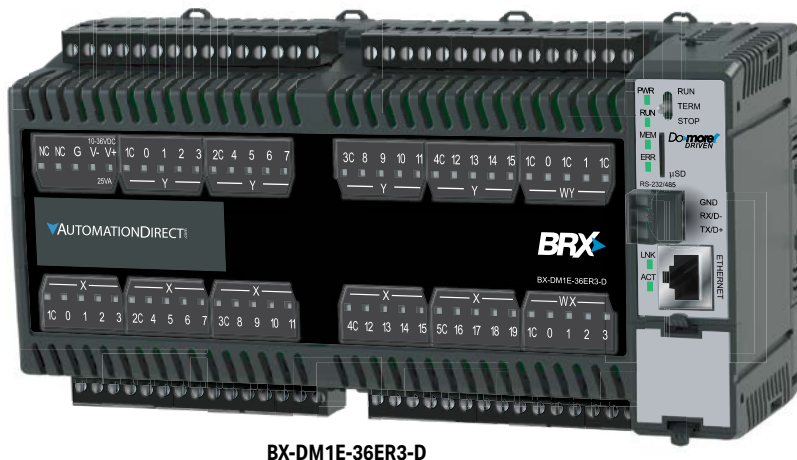

BX-DM1E-36ER3-D



NOTE: Eight (8) Expansion Modules can be connected to extend I/O capacity.

BX-DM1E-36ER3-D Wiring, Continued

Power Supply Specifications

Power Supply Specifications	
Nominal Voltage Range*	12–24 VDC
Input Voltage Range (Tolerance)*	10–36 VDC
Maximum Input Voltage Ripple	< ±10%
Maximum Input Power	30W
Cold Start Inrush Current	5A, 2ms
Maximum Inrush Current (Hot Start)	5A, 2ms
Internal Input Protection	Reverse polarity protection and undervoltage lockout via transistor circuit
Acceptable External Power Drop Time	10ms
Under Input Voltage Lock-out	<9VDC
Heat Dissipation	25.4 W Max
Isolated User 24VDC Output	None
Voltage Withstand (dielectric)	1500VAC power Inputs to ground applied for 1 minute
Insulation Resistance	>10MΩ @ 500VDC
Software Version Required	Do-more! Designer version 2.0 or later

*Class 2 or LPS Power Supply required.

Power Supply Connections

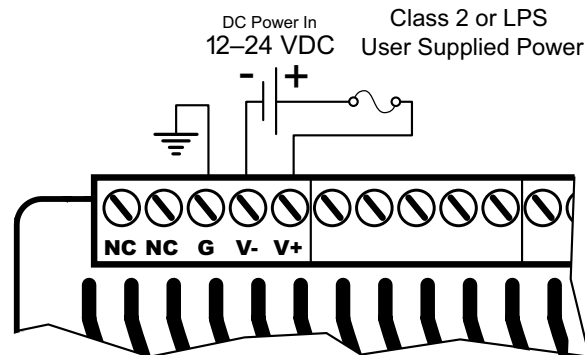

WARNING: No External AC power supply needed on this unit. The two terminals marked "NC" are not used. These terminals are not internally connected. **DO NOT CONNECT ANYTHING TO THESE TERMINALS!**



WARNING: The BRX System **MUST** have a proper earth ground. Do not operate the BRX MPU without proper earth grounding.

BX-DM1E-36ER3-D Wiring, Continued

Discrete Input Specifications

Discrete Input Specifications			
Input Type	Sink/Source		
Total Inputs per Module	20		
Commons	5 (4 points/common) Isolated		
Nominal Voltage Range	12–24 VAC/VDC		
Input Voltage Range	9–30 VAC/VDC		
Maximum Voltage	30 VAC/VDC		
DC Frequency	0–250 kHz - High-speed		
Minimum Pulse Width	0.5 μ s - High-speed		
AC Frequency	47–63 Hz ²		
Input Impedance	3k Ω @ 24VDC		
Input Current (typical)	6mA @ 24 VAC/VDC		
Maximum Input Current	12mA @ 30 VAC/VDC		
ON Voltage Level	> 9.0 VAC/VDC		
OFF Voltage Level	< 2.0 VAC/VDC		
Maximum OFF Current	1.5 mA		
Status Indicators	Logic Side, Green		
Input Details			
Input Type	High-Speed DC	Standard ¹	
Location	X0...X9	X10...X19	
OFF to ON Response	DC	< 2 μ s	2ms
	AC	–	10ms ²
ON to OFF Response	DC	< 2 μ s	2ms
	AC	–	10ms ²
Maximum Switching Frequency	DC	250kHz	
	AC	~ 30Hz	

- 1. All inputs may be used as standard inputs. Only the first 10 inputs (X0...X9) are capable of high-speed DC operation.*
- 2. 60Hz to 240Hz filter should be set in the software when using an AC line signal.*

BX-DM1E-36ER3-D Wiring, Continued

Discrete Input Connection Options

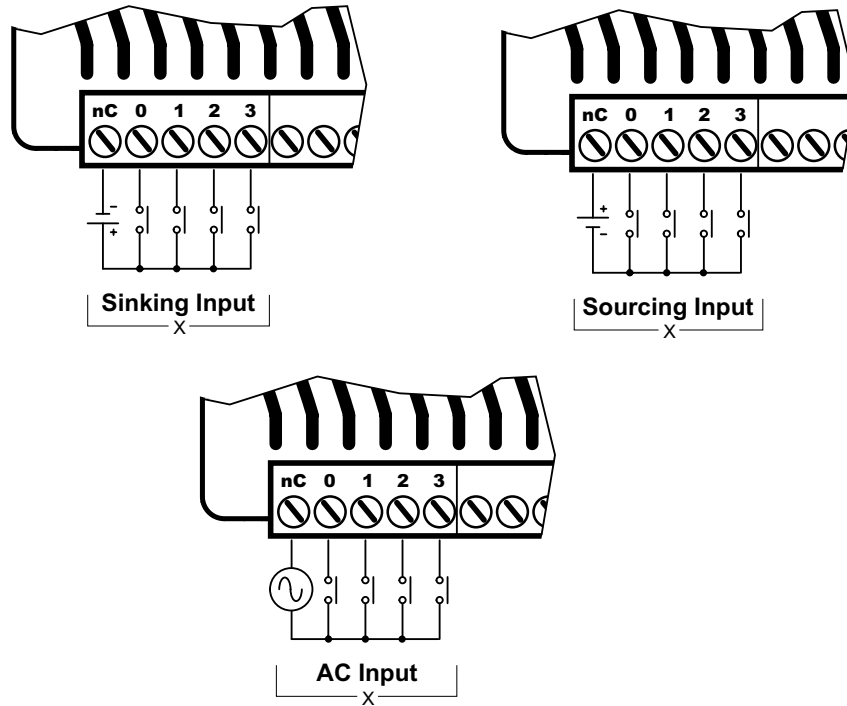

Discrete Input Internal Circuitry *

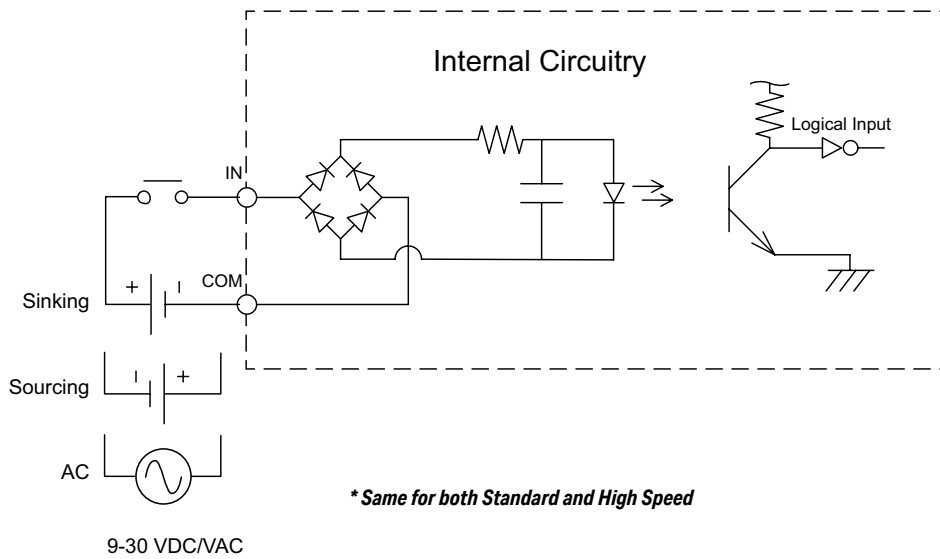

BX-DM1E-36ER3-D Wiring, Continued

Discrete Output Specifications

Discrete Output Specifications	
Output Type	Relay Form A (SPST)
Total Outputs per Module	16
Commons	4 (4 points/common) Isolated
Maximum Current per Common	8A
Nominal Voltage Range	12–48 VDC 24–240 VAC
Operating Voltage Range	5–60 VDC 5–264 VAC
Maximum Voltage	60VDC 264VAC
Minimum Output Current	0.1 mA @ 24VDC 0.1 mA @ 24VAC
Maximum Output Current	2A
Maximum Inrush Current	5A for 50ms
Maximum Leakage Current	1 μ A (DC), 300 μ A (AC) due to RC snubber circuit
ON Voltage Drop	0.2 V Max
Status Indicators	Logic Side, Green
Output Details	
Output Type	Standard
Location	Y0...Y15
ON-OFF Response	<10ms
OFF-ON Response	<10ms
Maximum Switching Frequency	10Hz
Relay Cycle Life	5 million operations
Mechanical Endurance	120,000 operations
Electrical Endurance	
Fuse Type	User-supplied external fuse

BX-DM1E-36ER3-D Wiring, Continued

Discrete Output Connection Options

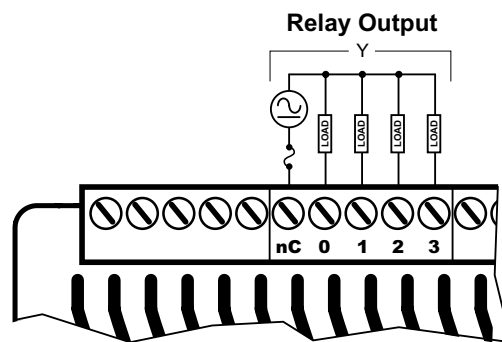

Discrete Standard Output Internal Circuitry

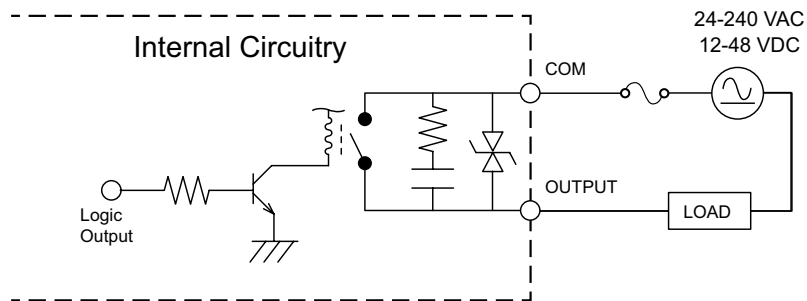

BX-DM1E-36ER3-D Wiring, Continued

Analog Input Specifications

Analog Input Specifications	
Inputs per Module	4
Commons	1
Input Voltage Range *	Software Selectable $\pm 10V$, $\pm 5V$, 0–10 V, 0–5 V
Input Current Range *	Software Selectable $\pm 20mA$, 4–20 mA
Resolution $\pm 10V$, $\pm 20mA$ $\pm 5V$ 0–5 V 4–20 mA 0–10 V	16 bits (0–65535 counts) 15 bits (0–32767 counts) 14 bits (0–16383 counts) ~15 bits (6553–32767 counts) 15 bits (0–32767 counts)
Input Impedance Voltage Modes	100k Ω
Absolute Maximum Input, Voltage Mode	$\pm 30V$
Input Impedance Current Modes	249 Ω
Absolute Maximum Input, Current Mode	$\pm 40mA$ sustained, $\pm 100mA$ for < 5s
Conversion Time	1.2 ms
Input Stability	0.02% of Full Hardware Range = 13 Counts
Full Scale Calibration Error	0.05% of Full Hardware Range = 33 Counts
Offset Calibration Error	0.01% of Full Hardware Range = 7 Counts
Accuracy vs Temperature Error	0.05% of Full Hardware Range = 33 Counts
Maximum Linearity Error (End to End)	0.1% of Full Hardware Range = 66 Counts
Maximum Inaccuracy	0.2% of Full Hardware Range = 131 Counts
Fuse Type	User-supplied external fuse

* Software selectable per channel

BX-DM1E-36ER3-D Wiring, Continued

Analog Input Connection Options

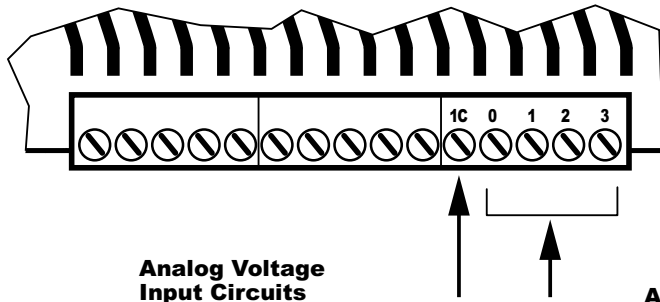

Analog Voltage Input Circuits

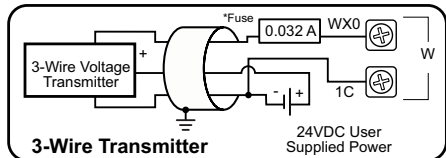
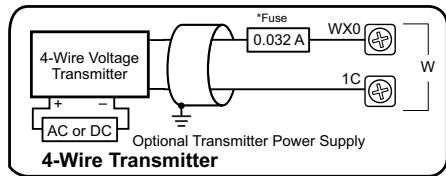

NOTE: Shield should be connected only at one end, to ground at the source device.

Analog Current Sinking Input Circuits

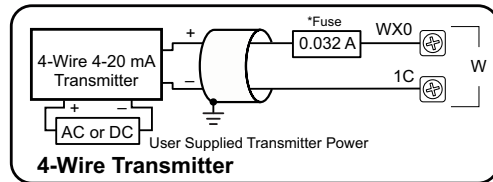
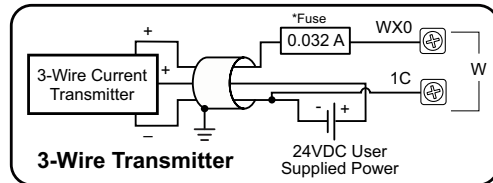
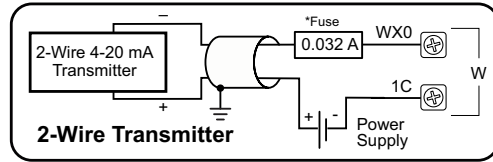

NOTE: Shield should be connected only at one end, to ground at the source device.



NOTE: An Edison S500-32-R 0.032A fast-acting fuse is recommended for all analog voltage inputs, analog outputs, and current loops.

BX-DM1E-36ER3-D Wiring, Continued

Analog Output Specifications

Analog Output Specifications	
Outputs per Module	2
Commons	3
Output Voltage Range *	Software Selectable $\pm 10V$, $\pm 5V$, 0–10 V, 0–5 V
Output Current Range *	Software Selectable $\pm 20mA$, 4–20 mA
Resolution $\pm 10V$, $\pm 20mA$ $\pm 5V$ 0–5 V 4–20 mA 0–10 V	16 bits (0–65535 counts) 15 bits (0–32767 counts) 14 bits (0–16383 counts) ~15 bits (6553–32767 counts) 15 bits (0–32767 counts)
Minimum Voltage Load Impedance	1k Ω
Maximum Current Load Impedance	500 Ω
Maximum Rating	Continuous Short Circuit Protected
Settling Time	< 1ms
Output Stability	0.02% of Full Hardware Range = 13 Counts
Full Scale Calibration Error	0.05% of Full Hardware Range = 33 Counts
Offset Calibration Error	0.01% of Full Hardware Range = 7 Counts
Accuracy vs Temperature Error	0.05% of Full Hardware Range = 33 Counts
Maximum Linearity Error (End to End)	0.1% of Full Hardware Range = 66 Counts
Maximum Inaccuracy	0.2% of Full Hardware Range = 131 Counts
Fuse Type	User-supplied external fuse

* Software selectable per channel

Analog Output Connection Options

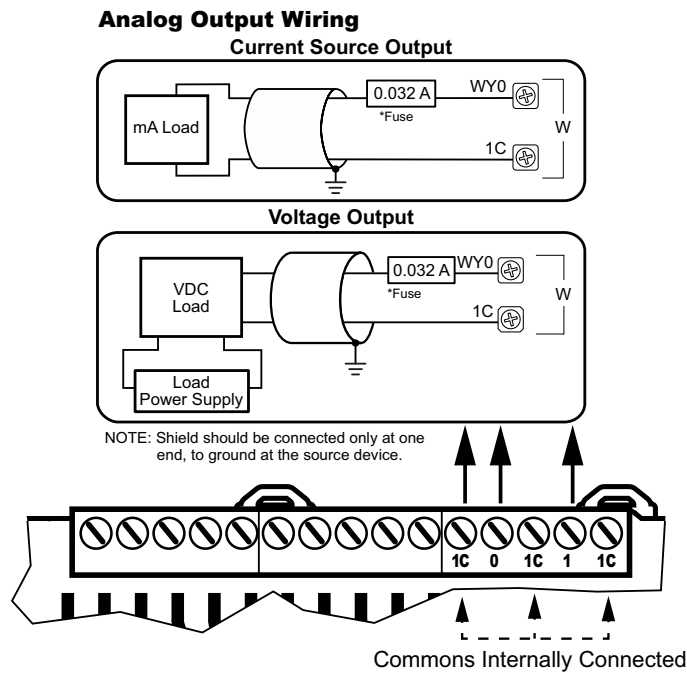

NOTE: An Edison S500-32-R 0.032A fast-acting fuse is recommended for all analog voltage inputs, analog outputs, and current loops.

BX-DM1E-36AR3 Wiring

This MPU is made up of 36 discrete I/O points. The connections are grouped as follows:

- 20 discrete inputs - AC rated for 120–240 VAC. They are located along the bottom of the unit; configured in five (5) groups of 5 terminals, each comprised of 4 inputs and an isolated common.
- 16 discrete outputs - Form A Relay (SPST); rated 12–48 VDC/ 24–240 VAC. They are located along the top of the unit starting to the right of the 24VDC auxiliary output terminals. The outputs are configured in four (4) groups of 5 terminals, each comprised of 4 outputs and an isolated common.
- 4 analog inputs and 2 analog outputs. The analog inputs are located along the bottom of the unit to the right of the discrete inputs. The analog inputs are grouped together on 5 terminals consisting of 4 input and a shared analog input common. The analog outputs are located along the top of the unit to the right of the discrete outputs. The analog outputs are grouped together on 5 terminals consisting of 2 outputs and 3 shared analog output common terminals. The analogs share these common features:
 - current or voltage selectable through software,
 - 16-bit resolution @ $\pm 20\text{mA}$, $\pm 10\text{VDC}$
 - current signal ranges of 4–20 mA, $\pm 20\text{mA}$,
 - voltage signal ranges of 0–5 VDC, 0–10 VDC, $\pm 5\text{VDC}$, $\pm 10\text{VDC}$.

This MPU requires an external 120–240 VAC power supply. The AC power supply connection and the 24VDC auxiliary output supply terminals are located on the top left side of the unit.

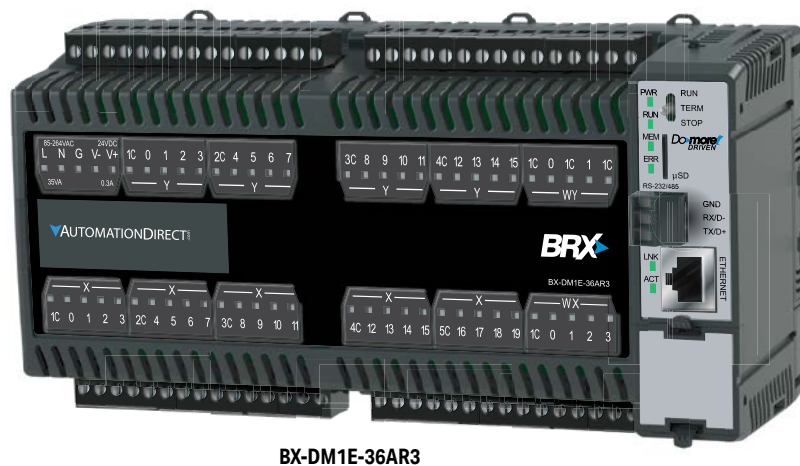

BX-DM1E-36AR3



NOTE: Eight (8) Expansion Modules can be connected to extend I/O capacity.

BX-DM1E-36AR3 Wiring, Continued

Power Supply Specifications

Power Supply Specifications	
Nominal Voltage Range	120–240 VAC
Input Voltage Range (Tolerance)	85–264 VAC
Rated Operating Frequency	47–63 Hz
Maximum Input Power	40VA
Cold Start Inrush Current	1.5 A, 2ms
Maximum Inrush Current (Hot Start)	1.5 A, 2ms
Internal Input Fuse Protection	Micro fuse 250V, 2A Non-replaceable
Acceptable External Power Drop Time	10ms
Under Input Voltage Lock-out	80VAC
Input Transient Protection	Input choke and line filter
Heat Dissipation	26.8 W Max
Isolated User 24VDC Output	24VDC @ 0.3 A max, <1V P-P Ripple, Integrated self-resetting short circuit protection
Voltage Withstand (dielectric)	1500VAC Power Inputs to Ground applied for 1 minute 1500VAC Ground to 24VDC Output applied for 1 minute
Insulation Resistance	>10M Ω @ 500VDC
Software Version Required	Do-more! Designer version 2.0 or later

Power Supply Connections

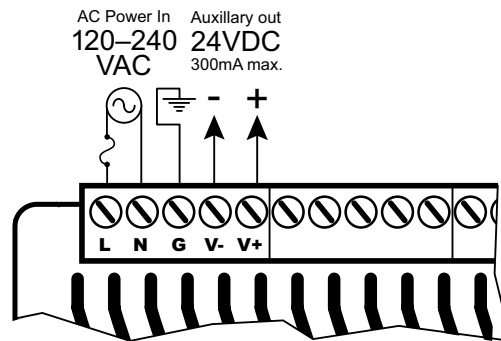

WARNING: Do not exceed the 24VDC auxiliary power supply load limit of 300mA.



WARNING: The BRX System **MUST** have a proper earth ground. Do not operate the BRX MPU without proper earth grounding.

BX-DM1E-36AR3 Wiring, Continued

Discrete Input Specifications

Discrete Input Specifications	
Input Type	AC
Total Inputs per Module	20
Commons	5 (4 points/common) Isolated
Nominal Voltage Range	120–240 VAC
Input Voltage Range	85–264 VAC
Maximum Voltage	264VAC RMS
AC Frequency	47–63 Hz
Input Impedance	15k Ω
Input Current (typical)	9mA @ 120VAC, 13mA @ 220VAC
Maximum Input Current	14mA @ 120VAC, 20mA @ 220VAC
ON Voltage Level	> 85VAC
OFF Voltage Level	< 40VAC
Maximum OFF Current	2.5 mA
Status Indicators	Logic Side, Green
Input Details	
Input Type	Standard
Location	X0...X19
OFF - ON Response	10ms
ON - OFF Response	10ms
Maximum Switching Frequency	~ 30Hz

Discrete Input Connection Options

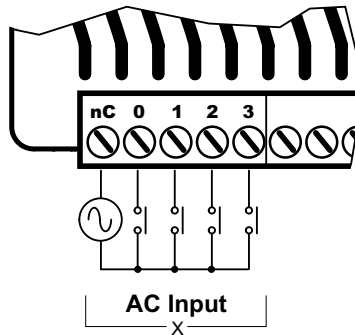

Discrete Input Internal Circuitry

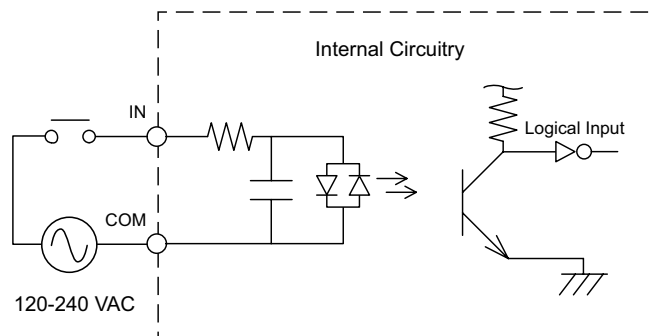

BX-DM1E-36AR3 Wiring, Continued

Discrete Output Specifications

Discrete Output Specifications	
Output Type	Relay Form A (SPST)
Total Outputs per Module	16
Commons	4 (4 points/common) Isolated
Maximum Current per Common	8A
Nominal Voltage Range	12–48 VDC 24–240 VAC
Operating Voltage Range	5–60 VDC 5–264 VAC
Maximum Voltage	60VDC 264VAC
Minimum Output Current	0.1 mA @ 24VDC 0.1 mA @ 24VAC
Maximum Output Current	2A
Maximum Inrush Current	5A for 50ms
Maximum Leakage Current	1 μ A (DC), 300 μ A (AC) due to RC snubber circuit
ON Voltage Drop	0.2 V Max
Status Indicators	Logic Side, Green
Output Details	
Output Type	Standard
Location	Y0...Y15
ON-OFF Response	<10ms
OFF-ON Response	<10ms
Maximum Switching Frequency	10Hz
Relay Cycle Life	5 million operations
Mechanical Endurance	120,000 operations
Electrical Endurance	
Fuse Type	User-supplied external fuse

BX-DM1E-36AR3 Wiring, Continued

Discrete Output Connection Options

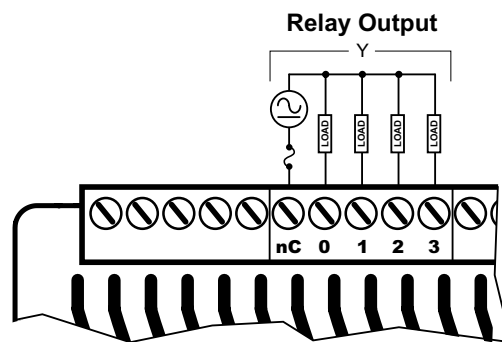

Discrete Standard Output Internal Circuitry

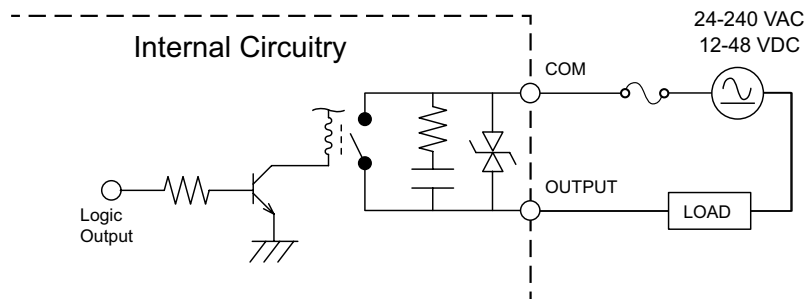

BX-DM1E-36AR3 Wiring, Continued

Analog Input Specifications

Analog Input Specifications	
Inputs per Module	4
Commons	1
Input Voltage Range *	Software Selectable $\pm 10V$, $\pm 5V$, 0–10 V, 0–5 V
Input Current Range *	Software Selectable $\pm 20mA$, 4–20 mA
Resolution $\pm 10V$, $\pm 20mA$ $\pm 5V$ 0–5 V 4–20 mA 0–10 V	16 bits (0–65535 counts) 15 bits (0–32767 counts) 14 bits (0–16383 counts) ~15 bits (6553–32767 counts) 15 bits (0–32767 counts)
Input Impedance Voltage Modes	100k Ω
Absolute Maximum Input, Voltage Mode	$\pm 30V$
Input Impedance Current Modes	249 Ω
Absolute Maximum Input, Current Mode	$\pm 40mA$ sustained, $\pm 100mA$ for < 5s
Conversion Time	1.2 ms
Input Stability	0.02% of Full Hardware Range = 13 Counts
Full Scale Calibration Error	0.05% of Full Hardware Range = 33 Counts
Offset Calibration Error	0.01% of Full Hardware Range = 7 Counts
Accuracy vs Temperature Error	0.05% of Full Hardware Range = 33 Counts
Maximum Linearity Error (End to End)	0.1% of Full Hardware Range = 66 Counts
Maximum Inaccuracy	0.2% of Full Hardware Range = 131 Counts
Fuse Type	User-supplied external fuse

* *Software selectable per channel*

BX-DM1E-36AR3 Wiring, Continued

Analog Input Connection Options

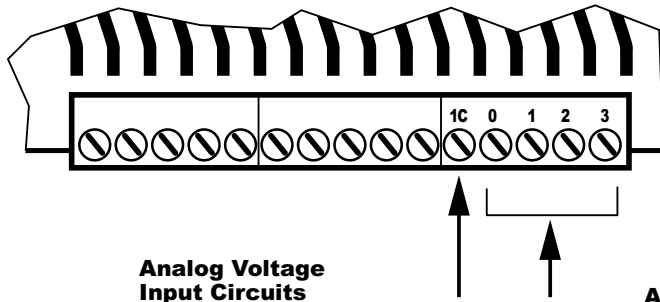

Analog Voltage Input Circuits

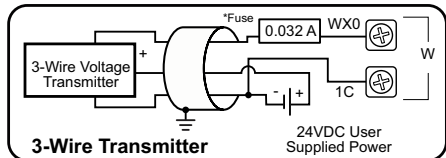
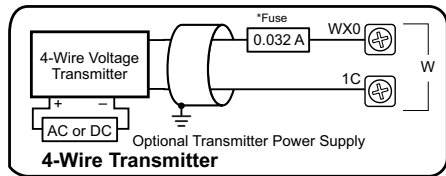

NOTE: Shield should be connected only at one end, to ground at the source device.

Analog Current Sinking Input Circuits

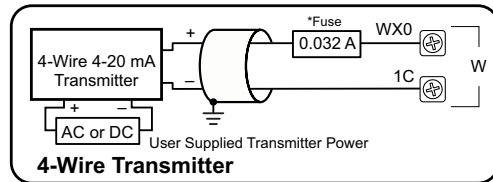
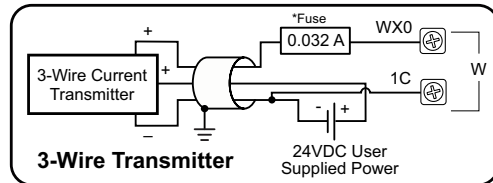
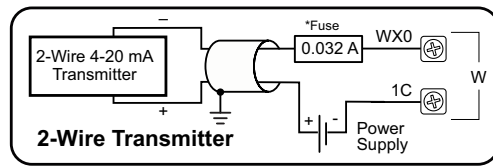

NOTE: Shield should be connected only at one end, to ground at the source device.



NOTE: An Edison S500-32-R 0.032A fast-acting fuse is recommended for all analog voltage inputs, analog outputs, and current loops.

BX-DM1E-36AR3 Wiring, Continued

Analog Output Specifications

Analog Output Specifications	
Outputs per Module	2
Commons	3
Output Voltage Range *	Software Selectable $\pm 10V$, $\pm 5V$, $0-10 V$, $0-5 V$
Output Current Range *	Software Selectable $\pm 20mA$, $4-20 mA$
Resolution $\pm 10V$, $\pm 20mA$ $\pm 5V$ $0-5 V$ $4-20 mA$ $0-10 V$	16 bits (0–65535 counts) 15 bits (0–32767 counts) 14 bits (0–16383 counts) ~15 bits (6553–32767 counts) 15 bits (0–32767 counts)
Minimum Voltage Load Impedance	1k Ω
Maximum Current Load Impedance	500 Ω
Maximum Rating	Continuous Short Circuit Protected
Settling Time	< 1ms
Output Stability	0.02% of Full Hardware Range = 13 Counts
Full Scale Calibration Error	0.05% of Full Hardware Range = 33 Counts
Offset Calibration Error	0.01% of Full Hardware Range = 7 Counts
Accuracy vs Temperature Error	0.05% of Full Hardware Range = 33 Counts
Maximum Linearity Error (End to End)	0.1% of Full Hardware Range = 66 Counts
Maximum Inaccuracy	0.2% of Full Hardware Range = 131 Counts
Fuse Type	User-supplied external fuse

* Software selectable per channel

Analog Output Connection Options

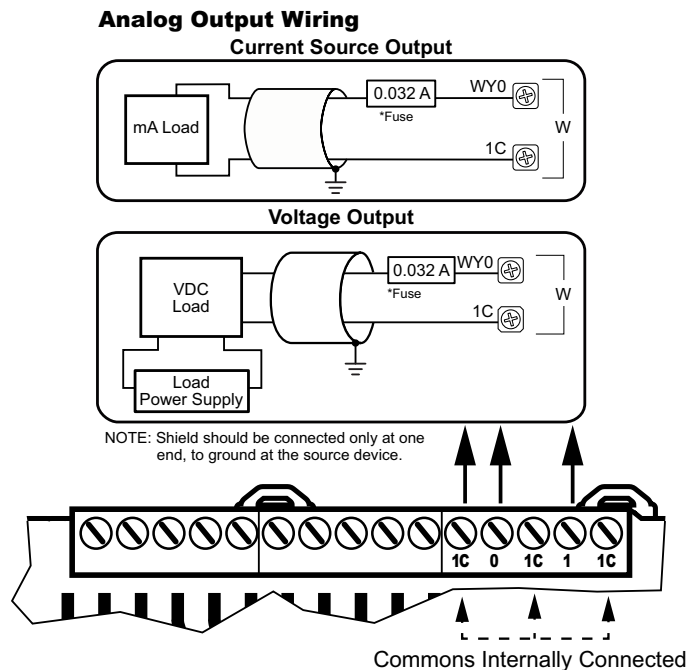

NOTE: An Edison S500-32-R 0.032A fast-acting fuse is recommended for all analog voltage inputs, analog outputs, and current loops.

Notes: